

(NASA-CR-120467) DEVELOPMENT AND TESTING  
OF LASER DOPPLER SYSTEM COMPONENTS FOR  
WAKE VORTEX MONITORING. VOLUME 2:  
SCANNER OPERATIONS (Lockheed Missiles and  
Space Co.) 92 p HC CSCL 14B

N74-33951

Unclas  
49797

G3/14

PRICES SUBJECT TO CHANGE

Reproduced by  
NATIONAL TECHNICAL  
INFORMATION SERVICE  
US Department of Commerce  
Springfield, VA. 22151

*Lockheed*

**HUNTSVILLE RESEARCH & ENGINEERING CENTER**

**LOCKHEED MISSILES & SPACE COMPANY, INC.**  
A SUBSIDIARY OF LOCKHEED AIRCRAFT CORPORATION

**HUNTSVILLE, ALABAMA**

LOCKHEED MISSILES & SPACE COMPANY, INC.  
HUNTSVILLE RESEARCH & ENGINEERING CENTER  
HUNTSVILLE RESEARCH PARK  
4800 BRADFORD DRIVE, HUNTSVILLE, ALABAMA

DEVELOPMENT AND TESTING  
OF LASER DOPPLER SYSTEM  
COMPONENTS FOR WAKE  
VORTEX MONITORING  
VOLUME II  
SCANNER OPERATIONS MANUAL

August 1974

Contract NAS8-29824

Prepared for National Aeronautics and Space Administration  
Marshall Space Flight Center, Alabama 35812

by

B. B. Edwards  
E. W. Coffey

APPROVED:

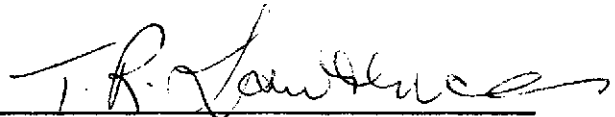

T. R. Lawrence, Supervisor  
Laser Systems Section

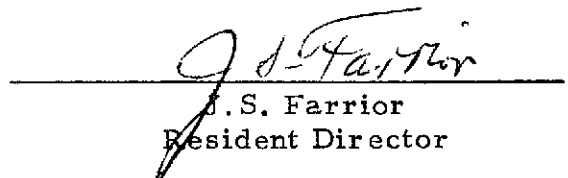

J. S. Farrior  
Resident Director

## FOREWORD

This document was prepared by personnel in the Laser Systems Section of the Huntsville Research & Engineering Center of Lockheed Missiles & Space Company, Inc.

The work described was accomplished under Contract NAS8-29824, "Development, Testing and Fabrication of Various Components of a Laser Doppler System." The NASA-MSFC technical monitors for this contract are Mr. J. W. Bilbro and Mr. H. B. Jeffreys, alternate, of S&E-AERO-AF. The period of performance was from May 1973 through August 1974.

## CONTENTS

Section		Page
	FOREWORD	ii
1	GENERAL INFORMATION	1
	1.1 Introduction	1
	1.2 System Specifications	1
2	OPERATING INSTRUCTIONS	2
	2.1 General	2
	2.2 Front Panel Controls	4
	2.3 Operating Instructions	7
	2.4 Scanner-Processor Interface	12
	2.5 Analog Recorder Outputs	13
3	THEORY OF OPERATION	14
	3.1 General	14
	3.2 Detailed Operation	15
	3.3 Elevation Servo	49
	3.4 Range Servo	55
	3.5 Interface Circuits	64
	3.6 Power Supply	64
4	SYSTEM TESTS	68
	4.1 Required Test Equipment	68
	4.2 Initial Adjustments and Alignment	68
	4.3 Elevation Controller Tests	73
	4.4 Range Controller Tests	79
	4.5 Servo Performance Tests	79
5	REPLACEABLE PARTS	83
	5.1 Integrated Circuits (All ICs in dual-inline package)	84
	5.2 Modular Components	86
	5.3 Miscellaneous Components	87

Section 1  
GENERAL INFORMATION

### 1.1 INTRODUCTION

This manual describes the theory and operation of the scanner portion of the laser Doppler system for detecting and monitoring aircraft trailing vortices in an airport environment. Included herein are schematics, wiring diagrams, component values, and operation and checkout procedures.

### 1.2 SYSTEM SPECIFICATIONS

The scanner system is capable of being scanned in elevation and range, either manually or automatically, between the limits and to the accuracies specified below. The system is capable of being manually set in azimuth only. For more information refer to Section 4 on system tests.

#### 1.2.1 Elevation

- a. Upper angle — thumbwheel adjustable from 10 to 59 deg,  $\pm 2$  deg
- b. Lower angle — thumbwheel adjustable from 0 to 59 deg,  $\pm 2$  deg
- c. Scan frequency — thumbwheel adjustable from 0.1 to 0.5 Hz,  $\pm 10\%$
- d. Manual slew — two switch selected rates, 3.4 deg per sec and 34 deg per sec,  $\pm 10\%$
- e. Single increment slew — maximum of 0.2 deg in either direction

#### 1.2.2 Range

- a. Maximum range — thumbwheel adjustable from 100 to 599 m,  $\pm 20$  m
- b. Minimum range — thumbwheel adjustable from 32 to 499 m,  $\pm 20$  m
- c. Scan frequency — thumbwheel adjustable from 0.1 to 6.9 Hz,  $\pm 10\%$
- d. Manual slew — two switch selected rates, 34 m/sec and 340 m/sec,  $\pm 10\%$
- e. Single increment slew — maximum of 2 m in either direction.

Section 2  
OPERATING INSTRUCTIONS

2.1 GENERAL

The LDV Scan and Track System is capable of four operating modes, three of which may be independently selected in range or elevation coordinates. The following nine arrangements are available by selecting the appropriate switch settings.

Range Elevation	MANUAL	AUTO (NORMAL)	AUTO (SEGMENT)
MANUAL	1	2	3
AUTO (NORMAL)	4	5	6
AUTO (SECTOR)	7	8	9

2.1.1 Manual Operation

In manual operating modes the range and elevation may be slewed at either of the selectable rates to the general vicinity of the required location in space. Then by operating the single increment controls the range is moved in 1 m steps and the elevation in 0.1 deg steps for fine adjustment.

2.1.2 Automatic Operation

In all automatic modes, either normal or sector, the controls do not position coordinates directly, but merely set the upper and lower limits between which the system scans at a frequency corresponding to that selected.

The scan speed is automatically corrected for any selected scan excursion so that the desired frequency can be achieved.

The primary difference between the NORMAL and SECTOR modes is that in the former the scan extremities are set in separately by the controls, while in the latter the mid-point or centroid, is set in and a symmetrical excursion to either side of this is performed.

Additional logic is provided to automatically prevent "crossover" of the upper and lower limits in the NORMAL mode, and to inhibit "underscan" in the SECTOR modes. ("Underscan" occurs when the mid-point is small and the excursion is large.)

### 2.1.3 Line Scan Operation

The fourth operating mode is the line scan, in which the range coordinate is forced to correspond to a point given by

$$R = R_h / \cos \phi_d$$

i.e., the range is automatically focused to a vertical line representing the side of right triangle with horizontal baseline,  $R_h$ , and line-of-sight angle,  $\phi_d$ .

When this operating mode is selected, the conditions above persist throughout all modes of elevation control.

FOLLOW THE OPERATING PROCEDURES TO ENSURE PROPER SEQUENCE OF SYSTEM ACTIVATION.
--

## 2.2 FRONT PANEL CONTROLS

The front panel controls, depicted in Fig. 1, are divided between three panels: the power supply panel, the main front panel, and the remote tracking panel. A brief description of each control follows.

### 2.2.1 Power Supply

- a. OFF-ON Switch – makes 115 Vac power available to system but no dc supplies are energized. ON indicated by red panel lamp immediately below switch
- b. START – applies 115 Vac to entire system through time-delay relay and latching relay. Energizes all dc supplies, indicated by amber panel lamp immediately below switch.
- c. STOP – removes 115 Vac from entire system. De-energizes all dc supplies. System can only be activated again by depressing START button.

### 2.2.2 Main Front Panel

#### 2.2.2.1 Range

- a. MODE SELECT – selects either manual or automatic operation
- b. FAST-SLOW – selects one of two manual slewing rates
- c. INCREASE-DECREASE – increases or decreases range manually at rate determined by FAST-SLOW switch
- d. SINGLE INCREMENT Pushbuttons – increase or decrease range in single increments of 2 m
- e. RANGE LED ASS'Y – indicates range in meters in either manual or automatic mode
- f. SCAN SELECT Switch – selects either normal or line scan mode. In line scan mode, blanks LED readout
- g. GROUND RANGE SELECT – selects desired horizontal range in meters for line scan mode
- h. MAXIMUM RANGE – selects desired maximum scan range in meters for automatic mode



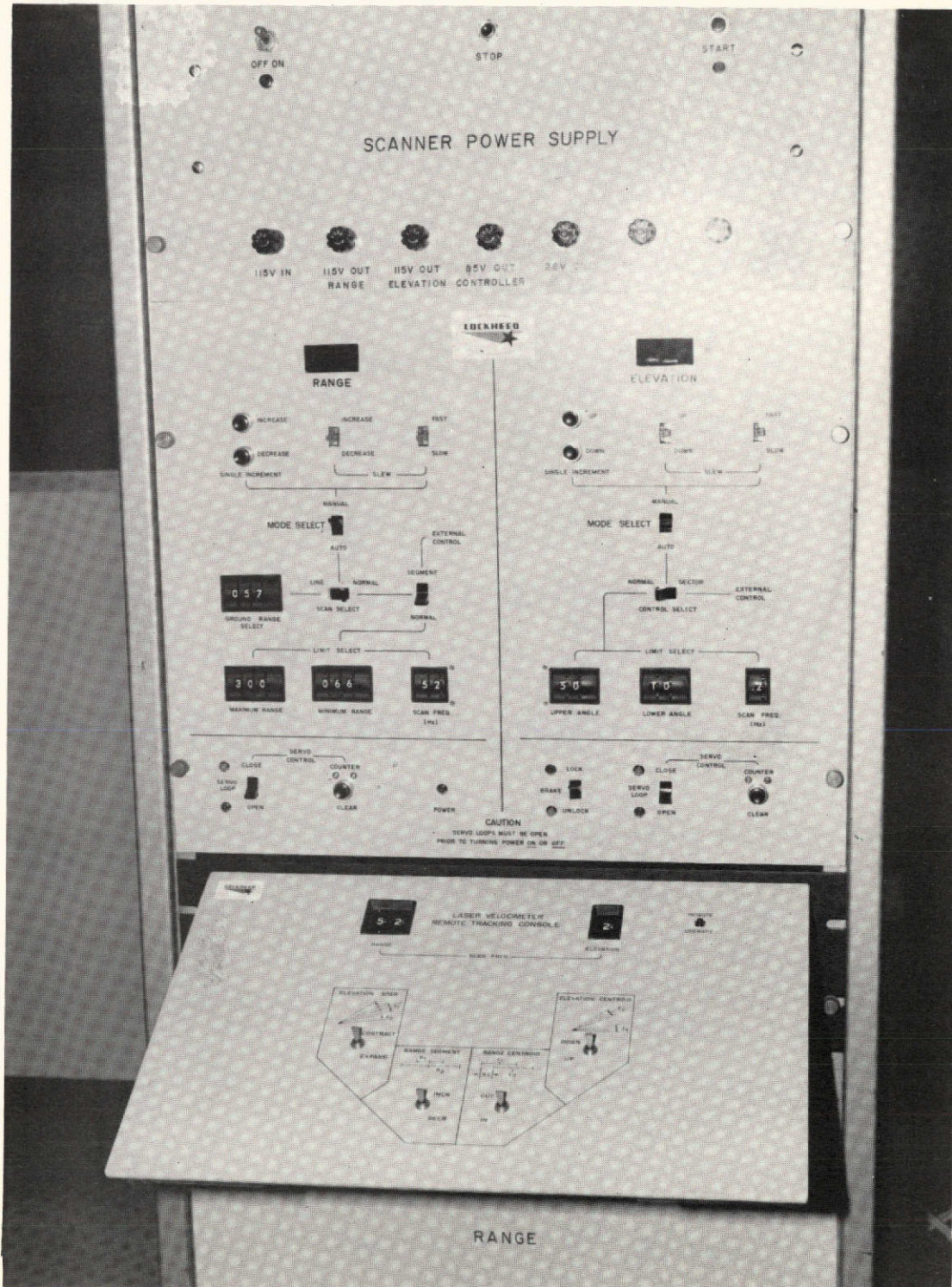

Fig. 1 - Scanner Front Panel Controls

- i. MINIMUM RANGE – selects desired minimum scan range in meters for automatic mode
- j. SCAN FREQ – selects desired scan rate for automatic mode
- k. SERVO CONTROL Switch – opens or closes drive to servo motor, indicated by green or red panel lamps adjacent to switch
- l. COUNTER CLEAR Pushbutton – resets control counter to zero state as indicated by LED readout. CLEAR function only available if SERVO CONTROL switch is in open loop position
- m. SEGMENT-NORMAL Switch – transfers control to remote tracking panel in SEGMENT position.

#### 2.2.2.2 Elevation

- a. MODE SELECT – selects either manual or automatic operation
- b. FAST-SLOW – selects one of two manual slewing rates
- c. UP-DOWN – increases or decreases elevation angle in single increments of 0.2 deg
- e. ELEVATION LED ASS'Y – indicates elevation angle in degrees and tenths in either manual or automatic mode.
- f. CONTROL-SELECT – transfers control to remote tracking panel in SECTOR position
- g. UPPER ANGLE – selects desired maximum elevation angle in automatic scan mode
- h. LOWER ANGLE – selects desired minimum elevation angle in automatic scan mode
- i. SCAN FREQ – selects desired scan rate for automatic mode.
- j. SERVO CONTROL Switch – opens or closes drive to servo motor, indicated by green or red panel lamps adjacent to switch
- k. COUNTER CLEAR – resets control counter to zero state as indicated by LED readout. CLEAR function only available if SERVO CONTROL switch is in open position
- l. BRAKE Switch – activates magnetic brake to lock elevation servo in position. This switch should not be activated when scanner is operating in automatic mode – see operating instructions. Brake condition indicated by green or red panel lamps adjacent to switch.

### 2.2.3 Remote Tracking Panel

The Remote Tracking Panel performs the function of providing a type of manual tracking mode. It can be activated in either range or elevation or both. The range portion is controlled by the SEGMENT-NORMAL switch on the Main Front Panel. The elevation portion is controlled by the SECTOR-NORMAL switch on the Main Front Panel. A red panel lamp indicates if either of these functions has been selected. When either function is selected, control of that function is transferred from the Main Front Panel to the Remote Tracking Panel. The switch functions are as follows:

- a. RANGE SCAN FREQ – selects the desired range scan rate
- b. ELEVATION SCAN FREQ – selects the desired elevation scan rate
- c. ELEVATION SPAN – expands or contracts the upper and lower scan limits symmetrically about a center position
- d. ELEVATION CENTROID – moves the center position up or down as desired.
- e. RANGE SEGMENT – expands or contracts the inner and outer range scan limits symmetrically about a center position
- f. RANGE CENTROID – moves the center position in or out as desired.

## 2.3 OPERATING INSTRUCTIONS

### 2.3.1 System Pre-Activation Requirements

NOTE: Before activating the system, the following must be completed.

#### 2.3.1.1 LDV System

1. Remove covers from the output and secondary mirrors.
2. Verify that the secondary mirror shaft is approximately at mid-travel position.

(Pre-Activation Requirements, Continued)

2.3.1.2 Main Control Panel

- |              |                   |
|--------------|-------------------|
| 1. Range     | SERVO LOOP – OPEN |
|              | MAN/AUTO – MANUAL |
|              | SLEW – SLOW       |
| 2. Elevation | SERVO LOOP – OPEN |
|              | BRAKE – LOCK      |
|              | MAN/AUTO – MANUAL |
|              | SLEW – SLOW       |

2.3.1.3 Power Supply

ON-OFF – UP/ON  
 START – PRESS ON, Release and wait 15 sec  
 before proceeding.

2.3.1.4 Main Control Panel

- |              |                                   |
|--------------|-----------------------------------|
| 1. Range     | COUNTER CLEAR – Press and Release |
|              | LED READOUT – Verify 000          |
| 2. Elevation | COUNTER CLEAR – Press and Release |
|              | LED READOUT – Verify 00.0         |

2.3.2 Manual Operation

2.3.2.1 Main Control Panel

- |          |  |
|----------|--|
| 1. Range | SERVO LOOP – Close                                       |
|          | LED READOUT – Indicates range position<br>last selected. |

Select Range Required as Follows:

SLEW  
 SINGLE INCR – INCR/DECR as required  
 for exact range location.

- |              |             |  |
|--------------|-------------|--|
| 2. Elevation | BRAKE       | - Unlock                                   |
|              | SERVO       | - Close                                    |
|              | LED READOUT | - Indicates last selected elevation angle. |

2.3.3 Automatic Scan Operation

NOTE: Automatic operation should not be selected prior to setup in manual mode.

2.3.3.1 Main Control Panel

- |              |                |   |
|--------------|----------------|---|
| 1. Range     | MAN/AUTO       | - MANUAL  |
|              | SCAN SELECT    | - NORMAL  |
|              | SEGMENT/NORMAL | - NORMAL  |
|              | LIMIT SELECT   | - Set required maximum and minimum range and scan frequency, then set.    |
|              | MAN/AUTO       | - AUTO  |
| 2. Elevation | MAN/AUTO       | - MANUAL  |
|              | CONTROL SELECT | - NORMAL  |
|              | LIMIT SELECT   | - Set required upper and lower angle limits and scan frequency, then set. |
|              | MAN/AUTO       | - AUTO  |

System operation may be stopped at any time by either:

MAN/AUTO - MANUAL (Preferable)

or

SERVO LOOP - OPEN.

NOTE: The counter clear operation of the system initial activation sequence places the counters of the sector scan logic in an abnormal "all zero" position. When using the sector scan mode for the first time after system activation, the following sequence must be completed before switching to the sector mode. (The following steps can be made while the system is in any mode other than sector scan.)

1. Hold the elevation span control to the "expand" position for one second, then to the "contract" position for one second, then release.
2. Hold the elevation centroid control to the "up" position for three sec, then release.
3. Hold the range segment control to the "increase" position for one sec, then to the "decrease" position for one sec, then release.
4. Hold the range centroid to the "out" position for three sec, then release.

This series of operations places the sector scan logic within the boundaries of the automatic limit controls. The following should be noted:

- a. The sector scan limits will remain at their last setting when switching to some other mode.
- b. The actual sector scan limits must be determined from the display, since there are no readouts which tell the operator what centroid and span values he has selected; the counters controlling these quantities are made to increase or decrease whenever the switches are held down, and stop when the switches are released or when one of the automatic limits has been encountered.

#### 2.3.4 Sector Scan Operation

##### 2.3.4.1 Perform Operations for Activation of Automatic Scan Mode

##### 2.3.4.2 LDV Remote Tracking Console

SCAN FREQ – Set both range and elevation rates to those set on main control panel.

##### 2.3.4.3 Main Control Panel

- |              |                |           |
|--------------|----------------|-----------|
| 1. Range     | SEGMENT/NORMAL | – SEGMENT |
| 2. Elevation | CONTROL SELECT | – SECTOR  |

2.3.4.4 LDV Remote Tracking Console

1. Verify that REMOTE OPERATE light is ON.
2. Console now controls all scan functions according to schematics in panel.

2.3.4.5 Reverse Procedure to Return to AUTO SCAN MODE.

NOTE: Do not turn power off with unit in Sector Scan Mode.

2.3.5 Line Scan Operation

NOTE: Line scan operation should not be selected prior to setup in manual mode.

2.3.5.1 Main Control Panel

- |              |  |
|--------------|--|
| 1. Range     | MAN/AUTO – MANUAL<br>SLEW – Select range to vicinity of<br>required test point<br>SCAN SELECT – LINE<br>GROUND RANGE SELECT – Set required upper<br>and lower angle<br>limits and scan<br>frequency. |
| 2. Elevation | MAN/AUTO – MANUAL<br>CONTROL SELECT – NORMAL<br>LIMIT SELECT – Set required upper and lower<br>angle limits and scan frequency.  |
| 3. Range     | MAN/AUTO – AUTO  |
| Elevation    | MAN/AUTO – AUTO  |

NOTE: By switching ELEVATION MODE to MANUAL the scan can be stopped and positioned to any point along the line. However, if the RANGE MODE is switched to MANUAL a fixed range arc is scanned.

## 2.3.6 System Deactivation

### 2.3.6.1 Main Control Panel

- |              |  |
|--------------|--|
| 1. Range     | MAN/AUTO – MANUAL<br>SLEW UP/DOWN – MID-RANGE<br>SERVO LOOP – OPEN   |
| 2. Elevation | MAN/AUTO – MANUAL<br>SLEW UP/DOWN – Approximate zero-degree elevation<br>SERVO LOOP – OPEN<br>BRAKE – LOCK |

### 2.3.6.2 Power Supply

STOP – PRESS and RELEASE

### 2.3.6.3 LDV System

Cover the output mirror and the secondary mirror.

## 2.4 SCANNER-PROCESSOR INTERFACE

The interface between the scanner and Signal Processor consists of the following binary signals.

- a. X-Coordinate – horizontal range coordinate of the scanner focus point
- b. Y-Coordinate – vertical height coordinate of the scanner focus point.
- c. Range scan sense signal – indicates direction in which range scan is moving (i.e., in or out)
- d. Clock signal – timing signal to determine discrete times at which the X and Y coordinates of scanner position are sampled.



The first three signals originate in the scanner during normal operation in any mode and are used by the Signal Processor for display purposes. The fourth signal is generated by the Signal Processor and used in the scanner to strobe out the data at the appropriate times. The X and Y coordinates consist of 10-bit words from an analog-to-digital converter. The range scan sense signal is a logic one when the range is increasing, and a logic zero when the range is decreasing. All logic levels are compatible with standard TTL logic.

## 2.5 ANALOG RECORDER OUTPUTS

There are two signals available from the scanner for recording on an analog recorder (strip chart, magnetic tape, etc.). These signals are buffered outputs of adjustable amplitude representing the position of the scanner in range and elevation.

The elevation signal is derived from the feedback potentiometer in the elevation servo loop. The range signal is derived from the digital-to-analog converter in the feedback loop of the range servo. For further details refer to the section of this manual dealing with the servo systems.

### Section 3

## THEORY OF OPERATION

### 3.1 GENERAL

The control unit generates 12-bit digital "words" which are used as position commands for the range and elevation servos, and adjusts the parameters of these control words in accordance with information set in on the control switches. For each of the controlled variables (range, elevation angle) there are available three basic operational modes, as follows:

1. Automatic Scan - Normal - This mode makes the control word execute a periodic excursion between selectable upper and lower limits, at one of a multiplicity of selectable frequencies (scan cycles/sec). The frequency is automatically maintained constant at the selected value irrespective of the magnitude of the scan excursion selected.
2. Automatic Scan - Sector - This mode results in the same type of motion as in (1), however, this mode permits the upper and lower limits to symmetrically expand or contract relative to a center position, using only one control, and permits the center position itself to be moved continuously over the region of interest by a second control. Counters (rather than thumbwheel switches) are employed to obtain these effects, thereby providing a type of tracking mode.
3. Manual Mode - This mode enables positioning of the controlled variable to any specific value where it will hold. Two slewing speeds and pushbuttons to give very small increments in either direction are also provided.

In addition to the above, the range variable is also provided with another mode, namely:

4. Line Scan - In this mode, the range positioning command is derived in the range servo itself in such a way that

the position of the external focus of the laser beam traverses a vertical line which intersects the ground plane at distance  $R_h$  away from the laser. The controller in this case merely provides the value of  $R_h$  (as a 12-bit word derived from a three-digit thumb-wheel switch).

Any pairwise combination of the three basic modes can be selected, and the line scan mode (4) can be used with any of the elevation modes. Mode parameters available are shown in the table on page 2.

### 3.2 DETAILED OPERATION

The information flow in the control system is depicted in the schematic on the following page for elevation. The range controller is nearly identical, the principal difference being the provision for the line scan mode made in the range servo system. A detailed review of the logic involved follows. The range and elevation cards are in most cases identical and interchangeable, with a few exceptions as noted below

#### 3.2.1 CE-1 (CR-1)

This card, shown schematically in Fig. 2, contains three cascaded, four bit up/down counters driving three output buffers to provide the 12-bit control word. In addition, there are two pairs of 5-bit comparators to sense when the word being generated is equal to, less than, or greater than certain particular values.\* Each pair consists of an upper limit comparator and a lower limit comparator. The pair controlling the manual mode employs hard-wire 5-bit comparison words (i e., fixed values), while the other pair uses variable words derived from those set in by the operator. There are altogether eight comparisons, which assume logical "high" ( $\approx +4$  V) when true. The counter can be in only four possible states, which are:

---

\* Values based on the five most significant bits of the word.

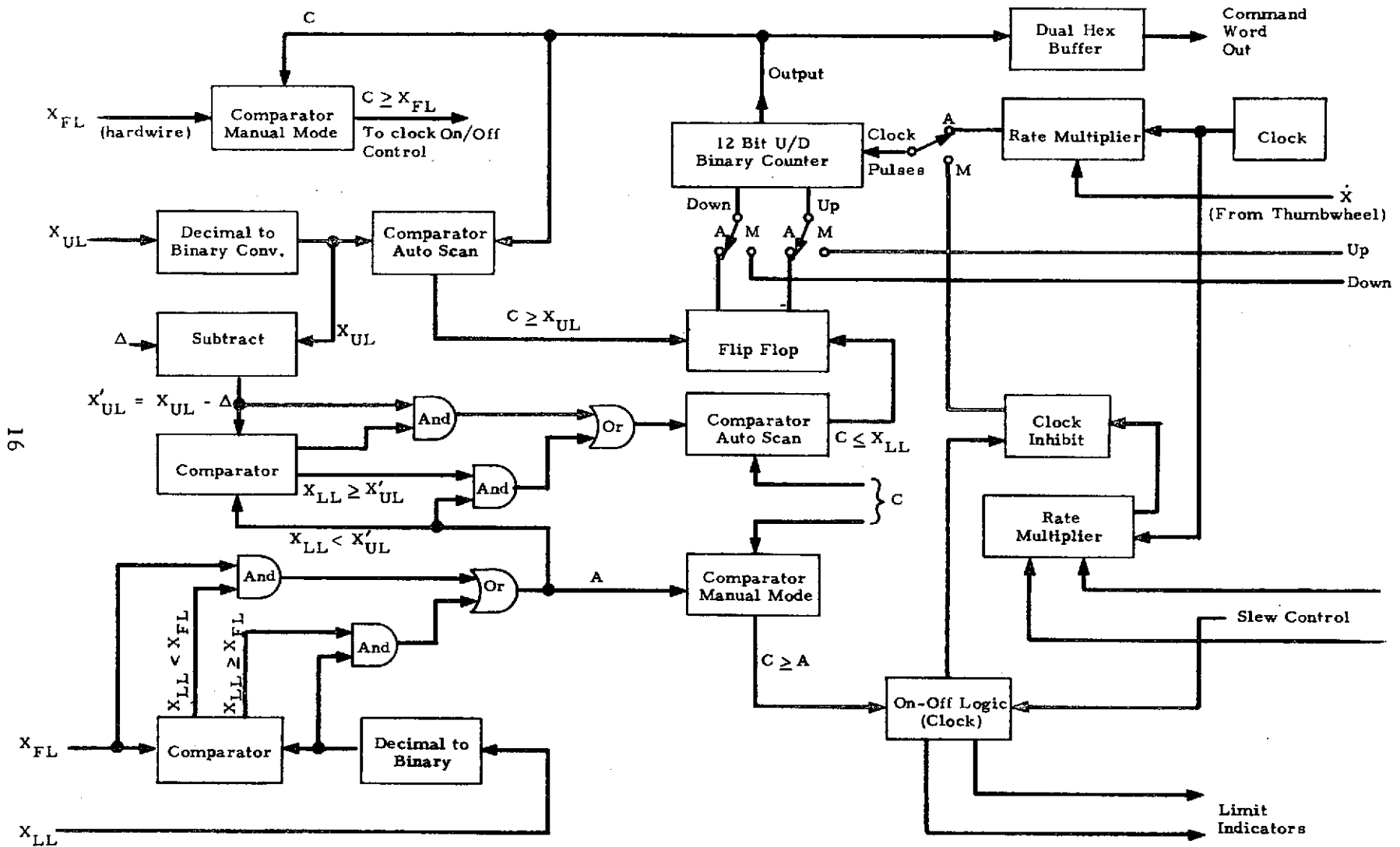

Elevation Control Logic

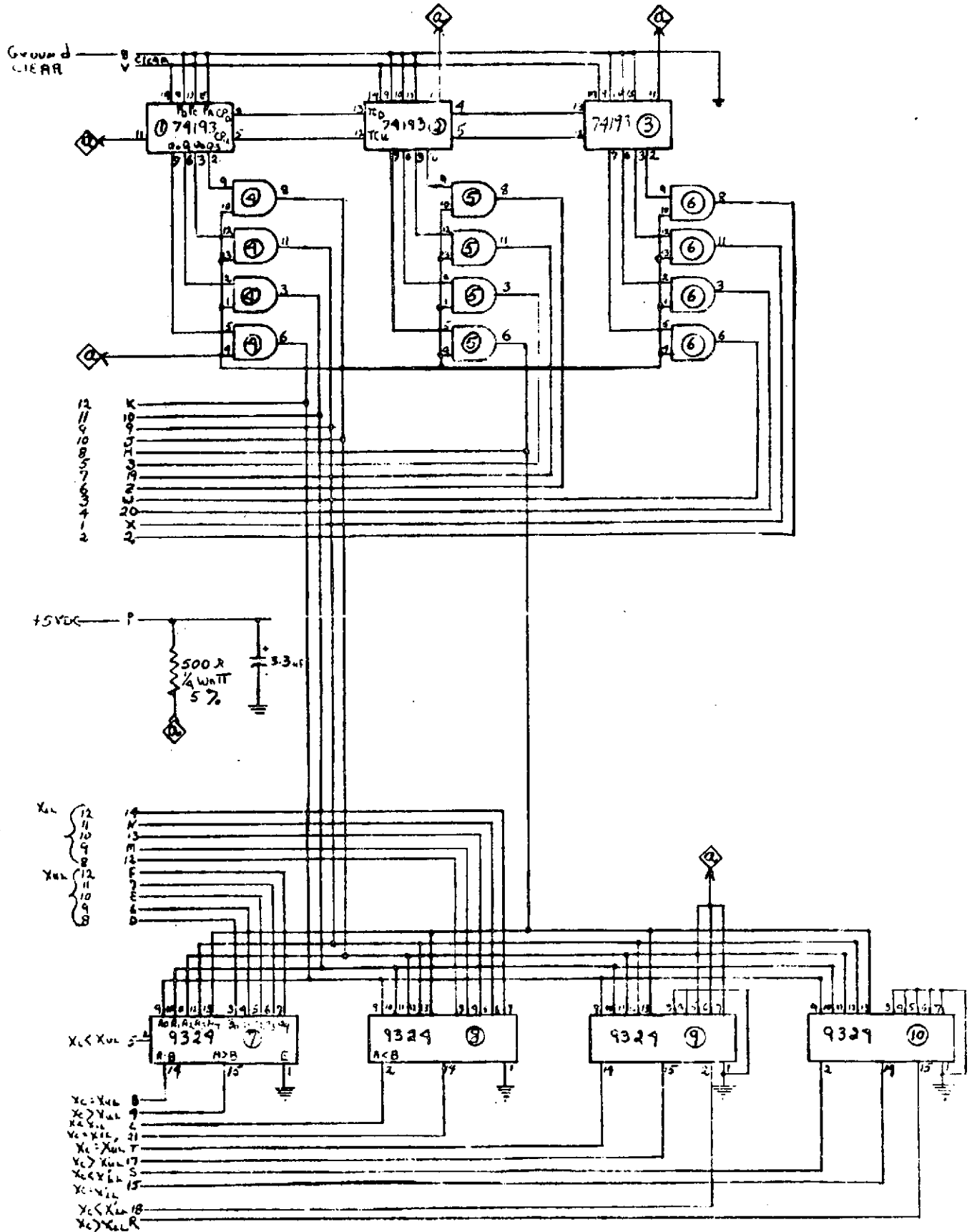

Fig. 2 - CE-1 (CR-1) Counter

State	Up Control	Down Control	Clear
Counting up	Clock pulses	High	Low
Counting down	High	Clock pulses	Low
Holding	High or low	High or low	Low
Clear	Irrelevant	Irrelevant	High

The first three states are provided by board CE-2 (CR-2), while the clear is provided by a front panel pushbutton. The clear forces the counter output to the all-zero state\*, irrespective of the up/down control states. While these counters have a "load" function which can make the output assume particular values, this feature is not used in the present implementation; the operator is informed of the control word value by the LED displays.

The values associated with the 12-bit words are given in the table below.

Bit No.	Elevation (deg)	Range (m)
12(MSB)	51.2	512
11	25.6	256
10	12.8	128
9	6.4	64
8	3.2	32
7	1.6	16
6	0.8	8
5	0.4	4
4	0.2	2
3	0.1	1
2	0.05	0.5
1 (LSB)	0.025	0.25

\*The clear function is available only when the servo is switched to open loop.

3.2.2 CE-2 (CR-2)

This board controls the counter, and has two basic modes, (a) automatic, (b) manual, which are selected by a front panel switch. This actuates the three relays  $S_1$ ,  $S_2$  and  $S_3$  (a "high" selects the manual mode).

We consider first the automatic mode, which can be in three possible states:

- a. Counter word in between the two limits: in this situation we have

$$\left. \begin{array}{l} X_c > X_{UL} \\ X_c = X_{UL} \\ X_c < X_{LL} \\ X_c = X_{LL} \end{array} \right\} \text{All false}$$

hence the outputs of the OR gates 5-3 and 5-11 are both low, since both pairs of inputs are low. This puts the J/K flip flop (IC-4) into condition 1 of its truth table, as shown below.

Condition	J	K	$Q_{n+1}$ (flip-flop output)
1	0	0	Same as $Q_n$ (no change of state)
2	0	1	Low
3	1	0	High
4	1	1	Opposite of $Q_n$ (change state)

The flip-flop output in this case remains unchanged, and whatever process had been going on in the counter continues to do so.

- b. Counter word is equal to (or possibly greater than) the upper limit.

In this case,

$$\begin{array}{l}
 X_c > X_{UL} \\
 X_c = X_{UL} \\
 X_c < X_{LL} \\
 X_c = X_{LL}
 \end{array}
 \left. \vphantom{\begin{array}{l} X_c > X_{UL} \\ X_c = X_{UL} \\ X_c < X_{LL} \\ X_c = X_{LL} \end{array}} \right\} \begin{array}{l} \text{One of these is true} \\ \\ \\ \text{Both false} \end{array}$$

This forces OR gate output 5-3 to the high state, while OR gate output 5-11 remains low, resulting in the condition 3 on the flip-flop. The consequent outputs

$$\begin{array}{l}
 Q = \text{high (pin 4-9, 8-9)} \\
 \bar{Q} = \text{low (pin 4-8, 8-13)}
 \end{array}$$

force OR gate output 8-8 to be high irrespective of the state of the clock inputs, and permits the output 8-11 of the other OR gate to respond only to the clock pulses. This is exactly the condition necessary to drive the counter down, which is what is called for, since the upper limit has been encountered. Note that when the output word diminishes so as to reenter state (a) (i.e., between limits), the flip-flop retains this "drive down" condition.

- c. It should now be evident that the lower limit encounter produces state 2 of the flip flop and a resulting "drive up" condition for the counter. (State 4 does not occur in this mode.) Note also that if the system happens to start off with the counter word outside the limits, it is automatically brought back in, to cycle between them, at a constant "velocity" determined by the clock rate.

Manual Mode: We start with the operation of the slewing switch and its associated OR gates (IC 1). The logical states available are shown in the following table.



Condition		Logical States - IC 1 Pins											
		1	2	3	4	5	6	13	12	11	10	9	8
Switch up	Manual Slew up	Hi	Hi	Lo	Lo	Lo	Hi	Lo	Lo	Hi	Hi	Hi	Lo
Switch down	Manual Slew down	Lo	Lo	Hi	Hi	Hi	Lo	Hi	Hi	Lo	Lo	Lo	Hi
Neutral* (center)	Manual hold or auto. scan	Hi	Hi	Lo	Lo	Lo	Hi	Hi	Hi	Lo	Lo	Lo	Hi
Outputs Used	Single Increment			X						X			

Note that this truth table is consistent with the quad NAND gate wiring of IC 1 as shown in the schematic (Fig. 3). This wiring provides a latching effect which guards against contact bounce on the switches.

As in the scanning mode, there are three possible states.

a. Counter word in between limits. In this case, both OR gate outputs 5-8 and 5-6 will be low (since both pairs of inputs are low), creating a "high" state on the output 6-10 of the NOR gate. This output acts as one of the inputs to each of the AND gates 2-(4, 5, 6) and 2-(10, 9, 8). Whichever of the OR gate outputs, 1-3 or 1-11, is high will then yield a high on its associated AND gate output; 2-6 if "down" is selected, or 2-8 if "up" is selected. (Note that 1-3 and 1-11 are mutually exclusive with respect to the high output.) This "high" state will also appear on the output of the associated OR gates 3-3 or 3-11, and also on the J or K inputs of the flip-flop IC-4, resulting in state No. 3 for down and state No. 2 for up; as noted previously, these flip-flop states are the appropriate ones to secure the corresponding motion. When the switch

---

\* The switch is spring-returned to neutral; while mechanical design ensures that the three positions are mutually exclusive, we rely on operator intelligence to refrain from using the up or down positions when he has already selected the auto scan mode, consistent performance of which requires that the switch be in the neutral position.

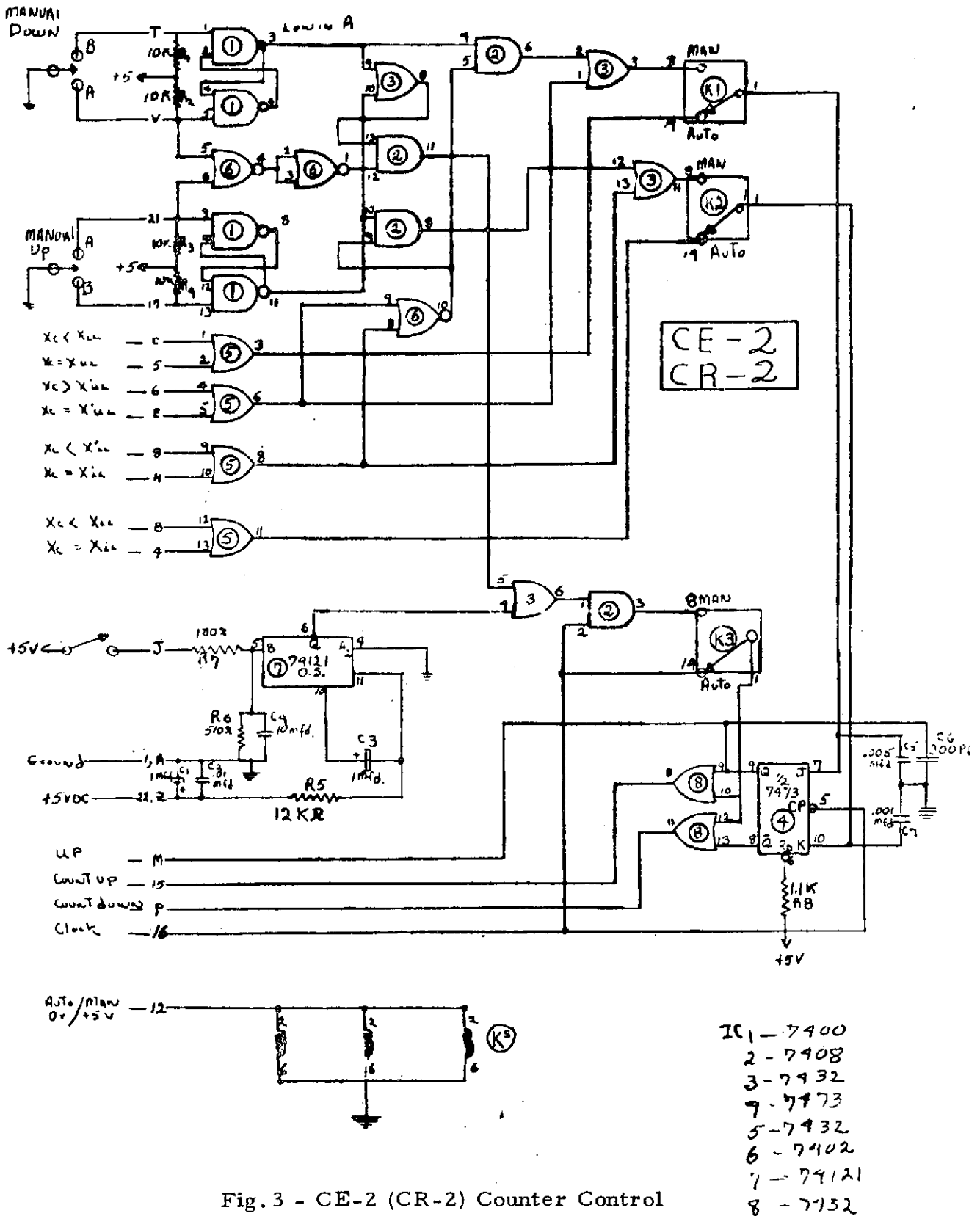

Fig. 3 - CE-2 (CR-2) Counter Control

is in the neutral position, and the counter is between limits, 3-3 and 3-11 are both low, resulting in the flip flop being in state 1. This would ordinarily make the counter continue its previous motion, but this is prevented by the removal of clock pulses in the neutral switch position.

Note that in the manual mode, clock pulses are obtained from the output of the AND gate 2-3, where one of the inputs is the clock. In order for clock pulses to appear at 2-3, and run the counter, the OR gate output 3-6 must be high. 3-6 can be made high either by the one-shot gate output on 3-4 being high, or by 3-5 being high, or both. We will assume 3-4 is low. Consider now the output of the cascaded NOR gates 6-(5, 6, 4) and 6-(2, 3, 1), which is connected to AND gate input 2-12. 2-12 will be low only if both 1-5 and 1-9 are low, but this condition is satisfied in the neutral switch position, so AND gate output 2-11, which is connected to 3-5, is low, inhibiting clock pulses in the neutral position.

When either up or down is selected, OR gate output 3-8 will be high, as will AND gate inputs 2-12 and 2-13, resulting in a high on 3-5 and consequently clock pulses in the selected direction so long as no limits have been encountered.

b. Output word encounters upper limit. In this case NOR output 6-10 goes low, forcing AND gate outputs 2-6 and 2-8 low, irrespective of other inputs to these two AND gates. OR gate outputs 5-6 and 5-8 will be high and low, respectively, resulting in a high on OR gate 3-4 and a low on OR gate 3-11, placing the flip flop in state 3, the "down" condition, irrespective of the slewing switch position. Since clock pulses are admitted for either non-neutral position of the slew switch (up or down), the counter will oscillate back and forth across the upper limit if "up" is selected, or move down if down is selected — in any case it will be impossible to slew beyond the upper limit.

c. Output word encounters low limit. It is clear that this produces the mirror image at condition (b) at the lower limit.

d. Single increment. The single increment switches perform the function of triggering the one-shot, IC-7, which generates a gate of length such as to admit sufficient clock pulses to move the command word by the desired small amount (as observed on the LED readout), and of "steering" the flip-flop IC-4 to the up or down condition. The gate triggering is accomplished simply by applying a "high" to 7-5. The steering is accomplished by applying appropriate inputs to IC-1 so that the outputs, 1-3 and 1-11, have the logic states appropriate to control the flip flop to select the desired direction. Note that, in order to make the one-shot gate be the only source of clock turn-on (and thus control the magnitude of the increment), we must maintain 1-5 and 1-9 in the "low" condition. This state of affairs is obtained with the following conditions on IC-1:

Position	IC-1 Input/Output States											
	1	2	3	4	5	6	13	12	11	10	9	8
Increment up	Hi	Hi	Lo	Lo	Lo	Hi	Lo	Hi	Hi	Hi	Lo	Hi
Increment down	Lo	Hi	Hi	Hi	Lo	Hi	Hi	Hi	Lo	Lo	Lo	Hi
Neutral	Same as Table 1											

These input conditions on 1-1, 1-5, 1-13 and 1-9 are established by the single increment push button switches. We observe that the operation of the upper limit and lower limit logic is the same as before.

### 3.2.3 CRE-3

This board provides the oscillator, dividers, and switching logic for obtaining the various clock frequencies required by both the elevation and range controllers as shown in Fig. 4.

The oscillator circuit has two NAND gates biased approximately in their linear region and connected through the crystal to form a positive-feedback loop. A third gate buffers the loop signal and delivers the output, which is approximately a square wave. Frequency stability is essentially that of the crystal, which operates in the series mode on the fundamental frequency.

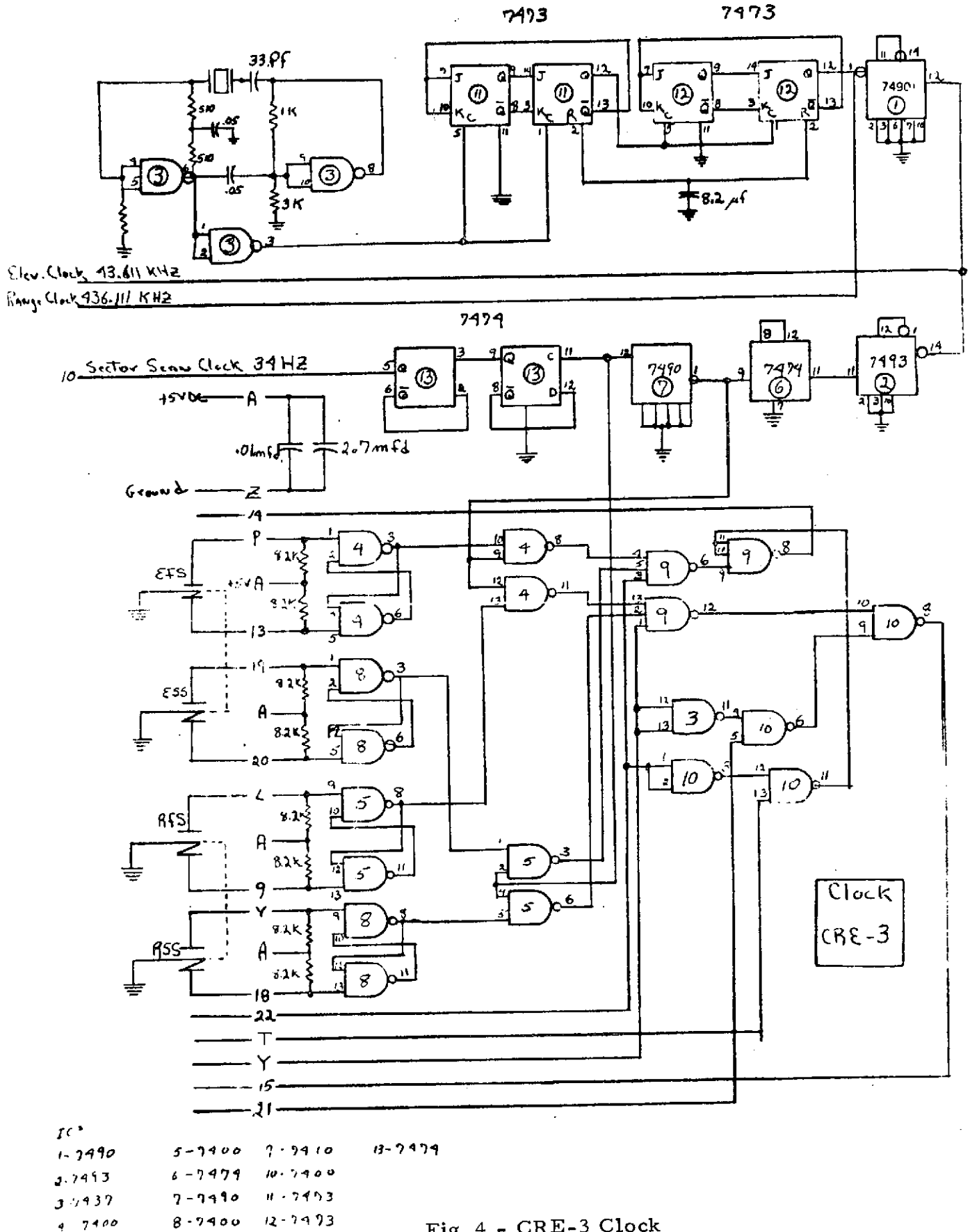

Fig. 4 - CRE-3 Clock

The small (33 pf) capacitor in series with the crystal provides the necessary high-impedance load to prevent "pulling" of the crystal frequency. The capacitor from the junction of the two 510-ohm resistors eliminates ac from the first gate's negative-feedback path. The capacitor between the two gates isolates the dc-bias loops. Its reactance is chosen to be small compared to that of the crystal so that the frequency is determined solely by the crystal.

This particular oscillator circuit performs best with crystals whose fundamental frequency is in the 1 to 5 MHz range (using standard TTL gates). Crystals were readily available cut to 3.925 MHz and this frequency was chosen as the basic clock frequency for the system.

The output of the oscillator goes directly to two cascaded divide-by-three circuits to obtain the desired clock frequency of 436.111 kHz for the range controller. A further division by ten yields the clock frequency of 43.6111 kHz for the elevation controller. These particular frequencies are necessary to achieve the desired scanning rates using the rate multiplication scheme described elsewhere.

For manual slewing of the servos much lower frequencies than those above are required. The elevation clock frequency is divided by a factor of 32 to obtain a frequency of 1363 Hz for fast slewing. Another division by ten provides 136.3 Hz for slow slewing. The final divider in the chain is a divide-by-four circuit which provides a frequency of 34 Hz for use in the sector-scan mode of operation.

The various modes of scanner operation are defined elsewhere in this document. These modes are affected by the switching logic on this board as described in the following paragraphs. Since the switching is all done with NAND gates, we will assume a particular mode of operation and show how the appropriate clock frequency is obtained. The other modes can then be seen to be obtained in a similar fashion.

Assume we wish to operate the elevation scanner in the manual mode and slew at the fast rate. The AUTO/MANUAL switch provides a logic one in the manual mode. The FAST/SLOW slewing switch is a double-pole, double-throw type connected such that only one function is available at a time (i.e., either fast or slow slew). The contacts of this switch are connected to cross-coupled NAND gates which serve as switch buffers and latches. In the fast slew position pin 4-9 is high and pin 5-1 is low. This makes pin 5-3 high and allows the 1363 Hz clock to appear at 9-6. Pins 9-10 and 9-11 are also high, allowing the 1363 Hz to appear at pin 9-8 where it is coupled out to the counter board (CE-2). Moving the switch to the slow slew position enables the appropriate gates to allow the 136.3 Hz clock to be coupled out. Note that moving the AUTO/MANUAL switch to auto provides a logic zero which disables the gates and neither slew rate is passed. In this case the clock is obtained from board CE-9 and gated out to board CE-2. The range rate is obtained in a similar manner.

#### 3.2.4 CR-3

This board, shown in Fig. 5, performs two functions, which are:

- a. Selects, in response to the LINE SCAN/NORMAL switch on the front panel, either the 12-bit range command word from the counter array on board 1, or a 12-bit word representing the ground range  $R_h$  originating at the  $R_h$  thumbwheel switch on the front panel. The selection function is performed by an array of three 9322 four-bit multiplexer ICs, which here act as four pole double throw switches.
- b. Provides, when the line scan mode is selected, three blanking controls for the three digit LED range displays. Since, in the line scan mode, the range command is generated internally in the range servo as an analog voltage, there is no digital version of this available to operate the LEDs so this display is simply blanked out in this mode. The selected 12-bit word is, in either mode, connected to board No. 4 where output buffering and conversion to a three decade BCD word is accomplished. Switching in the range servo makes

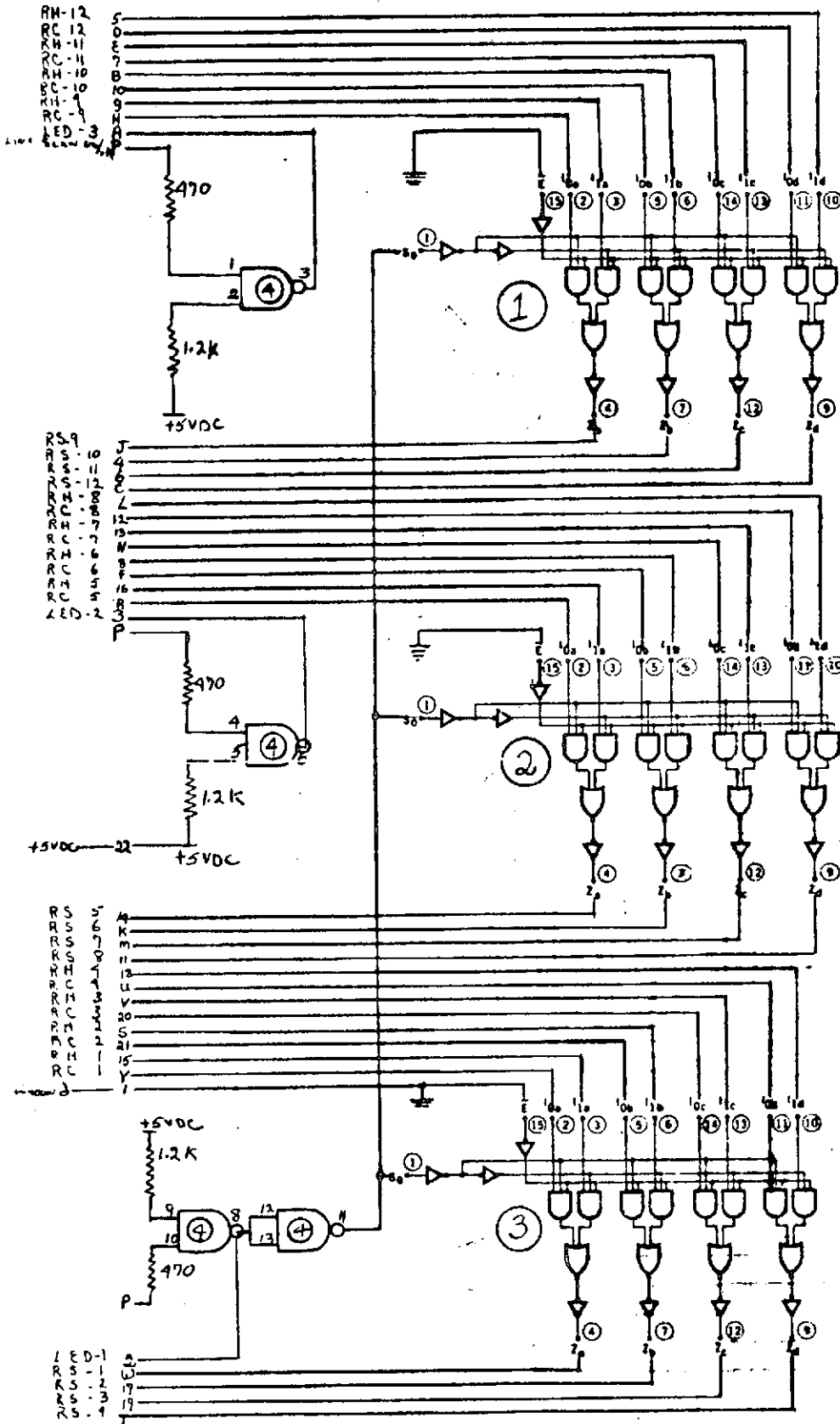

Fig. 5 - CR-3 Line-Scan Mode Switching



use of the  $R_c$  or  $R_h$  word appropriately to the selected mode, so that only one 12-wire cable is needed for range data from controller to range servo.

Board CR-3 has no counterpart in the elevation channel, since the line scan mode is unique to the range servo.

### 3.2.5 CR-4 (CE-4)

This board shown in Fig. 6 provides two functions:

- a. Output buffering for the 12-bit range word. This is provided by a pair of 6-bit inverters (7404) driving three "quad NAND" buffers (7437). The outputs feed the 12-wire cable connecting to the range servo.
- b. Conversion of the 12-bit range word into a three-decade BCD word. This is accomplished by the array of six binary/BCD decoders connected as shown in Fig. 6. Each IC accepts a 6-bit binary input, and is provided with internal logic such that if the lowest input bit is regarded as having value 1, the next 2, etc., and we assume that the bit having value 1 is used directly to play the role of the lowest order bit in the lowest order corresponding BCD output decade, then the outputs will have the following correspondences:

$$\begin{array}{rcl}
 Y_1 = "2" & \left. \vphantom{\begin{array}{l} Y_1 \\ Y_2 \\ Y_3 \\ Y_4 \\ Y_5 \\ Y_6 \end{array}} \right\} & \\
 Y_2 = "4" & & \text{Bit of lowest BCD decade} \\
 Y_3 = "8" & & \\
 Y_4 = "1" & \left. \vphantom{\begin{array}{l} Y_4 \\ Y_5 \\ Y_6 \end{array}} \right\} & \\
 Y_5 = "2" & & \text{Bit of next higher BCD decade} \\
 Y_6 = "4" & & 
 \end{array}$$

From these rules the truth table for the device can be constructed. The rules for cascading N such devices are rather complex, since "BCD outputs" must play the role of "binary inputs" for other decoders in the cascade. By using the rules given above, anyone sufficiently interested may verify that the

All Resistors are 1.3 k ohms 1/4 watt

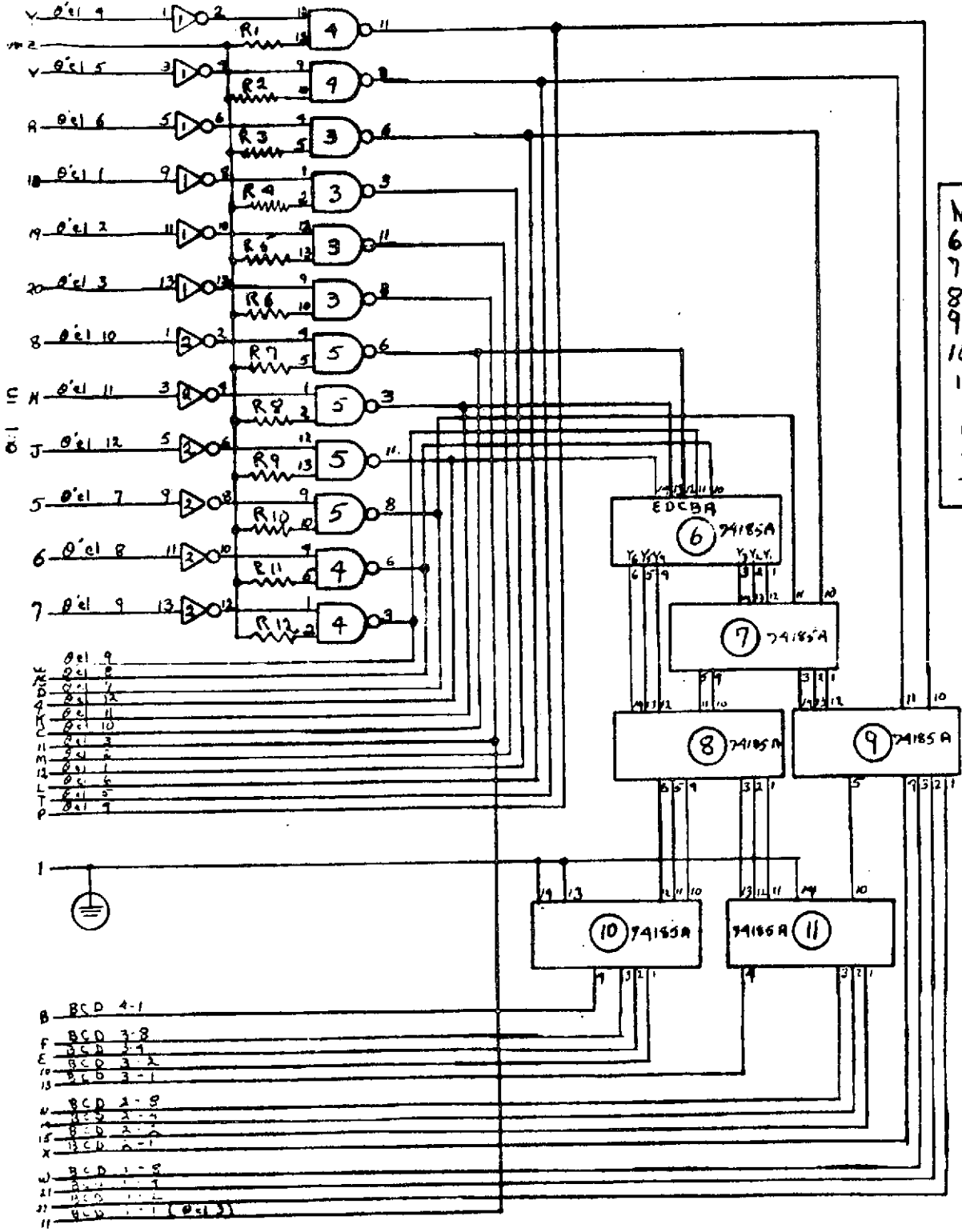

Note  
 6-1-6  
 7-1-5  
 8-1-6  
 9-1-5  
 10-1-4  
 11-1-4  
 each have  
 A Resistor  
 750R 1/4 watt  
 To +5VDC

- IC's
- 1-7409
  - 2-7404
  - 3-7437
  - 4-7437
  - 5-7437
  - 6-74185A
  - 7-74185A
  - 8-74185A
  - 9-74185A
  - 10-74185A
  - 11-74185A

CE-4  
 CR-4

Fig. 6 - CE-4 (CR-4) BCD Converter/Buffer

cascade shown in Fig. 6 does indeed provide correctly the three BCD decades for the 10-bit input word; it will also be discovered that six such ICs are both necessary and sufficient for a 10-bit binary input.

The reason for providing the BCD version of the command word is that the LED display requires this input format. Since we display the range word in units, tens, and hundreds and the elevation word in tenths, units, and tens, we need only employ the top ten bits of the 12-bit words. (Note: Although the true scale factor of the elevation word is  $\text{LSB} = 0.025$  degrees, in the decoder we proceed as if the scale were ten times greater, and simply read the lowest decade as tenths instead of units.)

### 3.2.6 CE-5 (CR-5)

This board is part of the circuitry required to maintain the scan frequency of the automatic scan at the selected value for any and all values of the scan excursion. It is clear that since the variables move at the rate of one LSB for each clock pulse applied to the generating counter, the frequency of the scan will be

$$f_s = \frac{1}{T} = \frac{2 f_c \Delta}{X_{UL} - X_{LL}} \quad (1)$$

where

- $f_s$  = scan frequency, Hz
- $f_c$  = clock rate (pulses/sec) applied to counter
- $\Delta$  = value of least significant bit
- $X_{UL}$  = upper limit of scan
- $X_{LL}$  = lower limit of scan

Hence the required clock to achieve a particular  $f_s$  is:

$$f_c = \frac{(f_s)(X_{UL} - X_{LL})}{2\Delta} \quad (2)$$

from which it is clear that we must determine the excursion span (by subtracting the lower limit from the upper limit), and make the clock rate proportional to the product of this value and the selected scan frequency  $f_s$ . Board No. 5 performs the subtraction, with the results available as a 12-bit binary number, and then uses this to generate a clock rate proportional to this value. This clock rate is then subjected to a second "multiplication" to complete the process (see CE-9).

Consider first the subtraction. Here we employ the relation

$$N_2 - N_1 = [N_2^* + N_1]^* \quad (3)$$

where

$N_2$  = binary number representing upper limit

$N_1$  = binary number representing lower limit

and ( )<sup>\*</sup> denotes complementation

The relation (Eq. ( 3 )) yields correct results only when  $N_2 > N_1$  and both are  $> 0$ , but these relations are satisfied in this system.

The operation expressed in Eq. ( 3 ) is implemented as follows:<sup>†</sup>

a. The six bit inverters IC-1, IC-2 (7404) perform the complementation of the lower limit  $X_{LL}$ .

b.  $X_{LL}^*$  and  $X_{UL}$  (the upper limit) are summed in the three adders IC-3, IC-4, IC-5 (7483). Each adder sums two 4-bit binary numbers, and accepts a carry from a lower group of four and generates a carry (if the sum calls for this) for the succeeding higher stage.

<sup>†</sup>See Fig. 7.

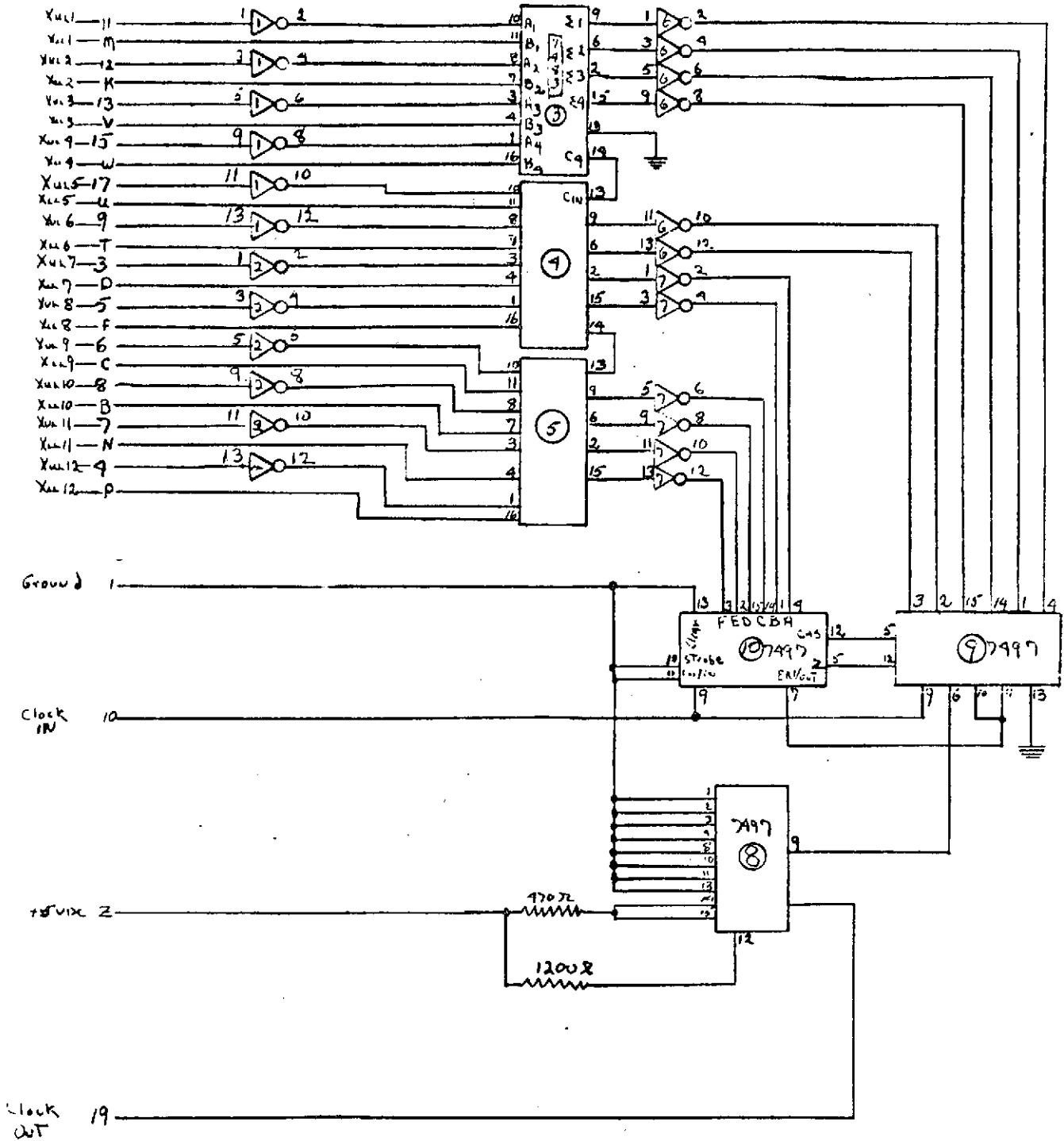

CE-5  
CR-5

IC<sup>s</sup>

7483 is a Full Adder

7497 is a six-bit serial binary counter

1,2,6,7 are 7909

Fig. 7 - CE-5 (CR-5) Scan Control

c. The result of the sum is complemented by the 6-bit inverters IC-6, IC-7 (7404).

The multiplication needed is carried out by the rate multipliers IC-8, IC-9 and IC-10. IC-9 and IC-10 are cascaded so as to operate as a unit with a 12-bit input word (individual units employed a 6-bit control word), while IC-9 is arranged to give a constant multiplication to adjust the scale factor. The overall operation with respect to rate is

$$f_{\text{out}} = f_{\text{in}} \times \frac{(N_2 - N_1)}{64 \times 64} \times \frac{12}{64} \quad (4)$$

where  $N_2$  is the upper limit expressed in a scale of  $\text{LSB} = 1$ , and  $N_1$  is the lower limit expressed in the same scale. The value of  $f_{\text{in}}$  actually used is

$$\begin{aligned} f_{\text{in}} &= 43.61 \text{ kHz} && \text{for elevation} \\ f_{\text{in}} &= 436.1 \text{ kHz} && \text{for range} \end{aligned}$$

Some remarks are in order regarding the operation of these devices:

1. The internal logic of each IC is a series of cascaded flip flops and multiple-input AND gates. The latter generate an output high whenever there is a time-coincident high on all inputs and the control bit is also high; if the control bit is low, no output appears. This sets up a series of "time slots" at spacings corresponding to every  $2^n$  clock pulses, where  $n$  is the order of the control bit. For cascading to 12 bits, the cross connections shown in Fig. 7 (IC-9 and IC-10) are made.
2. Since the basic operations are those of counting and time coincidence logic, output clock pulses have the same width as those on the input, and can appear (if they are present at all) only at input clock pulse high periods. The control word input determines the presence or absence of the output clock pulses. It is clear that a periodic input will, in general, generate output sequences which do not have a constant inter-pulse spacing, i.e., the average rate satisfies Eq. (4) but the "instantaneous" rate may be considerably different. Because of the small value of the LSB corresponding to individual clock pulses, this time jitter effect is not noticeable in the servos.

3. Because of the synchronous operation, it is not necessary to provide a periodic clock input — the counting operation merely senses change-of-state events and their number, and the logical operations are invariant with respect to variations of the inter-pulse spacing of the control clock. This permits cascading of successive multiplications, such as that shown on Fig. 7 where the clock output from the cascade IC-9, IC-10, drives the "constant" multiplier IC-8 (the "hardwired" high on pins 14, 15 have bit values 4 and 8), hence give a multiplication factor of  $12/2^n = 12/2^6 = 12/64$ .
4. A convenient way of externally checking the board is to input a clock having frequency

$$f_{in} = (64 \times 64 \times 64)/12 = 21.84533 \text{ kHz}$$

in which case the output frequency (conveniently measured on a standard counter — e.g., Hewlett Packard 5325-A) will be directly equal in Hz to the difference in the binary numbers representing  $X_{UL}$  and  $X_{LL}$  on a scale where  $LSB = 1$ .

If the board fails to satisfy Eq. (4) even when the bits representing  $N_1$  and  $N_2$  have the expected values, the best recourse is to replace the ICs, bearing in mind that Nos. 9 and 10 must function as a unit.

### 3.2.7 CE-6 (CR-6)

The function of this board is to prevent the occurrence of a lower limit which is greater than, or nearly equal to, the upper limit, when in the automatic scan mode. This would result in an unsafe and ambiguous scanning condition (the variable would be stationary within one LSB at some position within or on the edge of the overlap region), and there is nothing which prevents an input thumbwheel setting from creating this condition.

The implementation as shown in Fig. 8 is such as to compare the called-for lower limit with another limit which is 9.6 degrees (or 96 meters for the range variable) smaller than the called-for upper limit. Should the dialed-in lower limit exceed this value, it is replaced by the new one, so that it is impossible to set in a lower limit which is not at least 9.6 degrees smaller than the upper limit. The implementation is as follows:

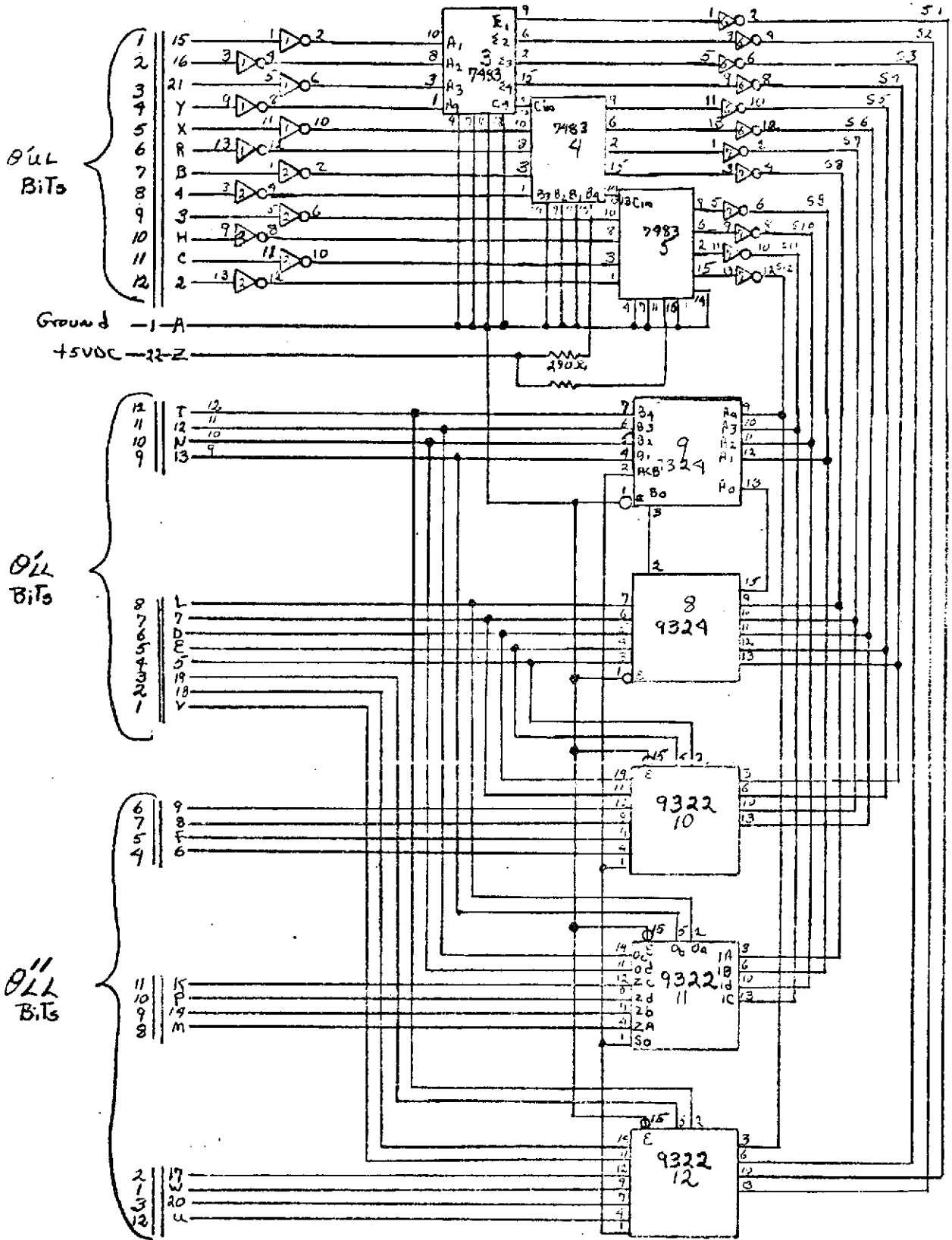

Fig. 8 - CE-6 (CR-6) Anti-Crossover Logic



a. 9.6 degrees is subtracted from the upper limit. This is done with the same subtraction algorithm used on board No. 5. The upper limit word is first complemented with the two 6-bit inverters (7404) IC-1 and IC-2, summed in 4-bit adders (7483) IC-3, IC-4, and IC-5 with a hard-wire "word" equal to 9.6 degrees (appearing as a high value on 5-11 (bit No. 9 = 6.4 degrees) and 4-16 (bit No. 8 = 3.2 degrees)), and the sum complemented in IC-6 and IC-7 6-bit inverters (7404). This complemented sum, which is actually  $X_{UL} - 9.6$  degrees, is then compared with the dialed-in lower limit in the cascaded comparators IC-8 and IC-9. (The cascading is simply accomplished by connecting the  $A > B$  and  $A < B$  outputs of the lower order stage to the lowest order "A" and "B" inputs, respectively, of the higher order stage - it is easily seen that this gives the desired operation. The comparison outputs ( $A > B$ ,  $A < B$ ,  $A = B$ ) are then valid. This gives a 9-bit capability, which is sufficiently accurate for our purpose.) If A (the dimensioned upper limit) is less than B (the lower limit), 9-2 becomes high and activates the array of 4-bit selectors IC-10, 11 and 12 (9322). If the  $A < B$  condition is true, the diminished upper limit appears on the output; if not, the unchanged lower limit appears on the output.

### 3.2.8 CE-7 (CR-7)

This board, in conjunction with No. 8, is part of the implementation of the sector scan mode. The operations implemented on CE-7 are as follows:\*

- a. Generation of an 8-bit word representing half of the desired span (distance between upper and lower limits) in the sector mode.
- b. Generation of the lower limit by subtraction of the half-span word from an input word representing the center position of the sector mode.

The half-span word is generated by the 8-bit up/down counter comprised of the cascaded pair IC-1 and IC-2 (74193). Up/down control is implemented in conjunction with slew switch inputs (originating at the sector scan control panel), the quad OR gates in IC-5 (7432), and outputs from the comparators

---

\* See Fig. 9.

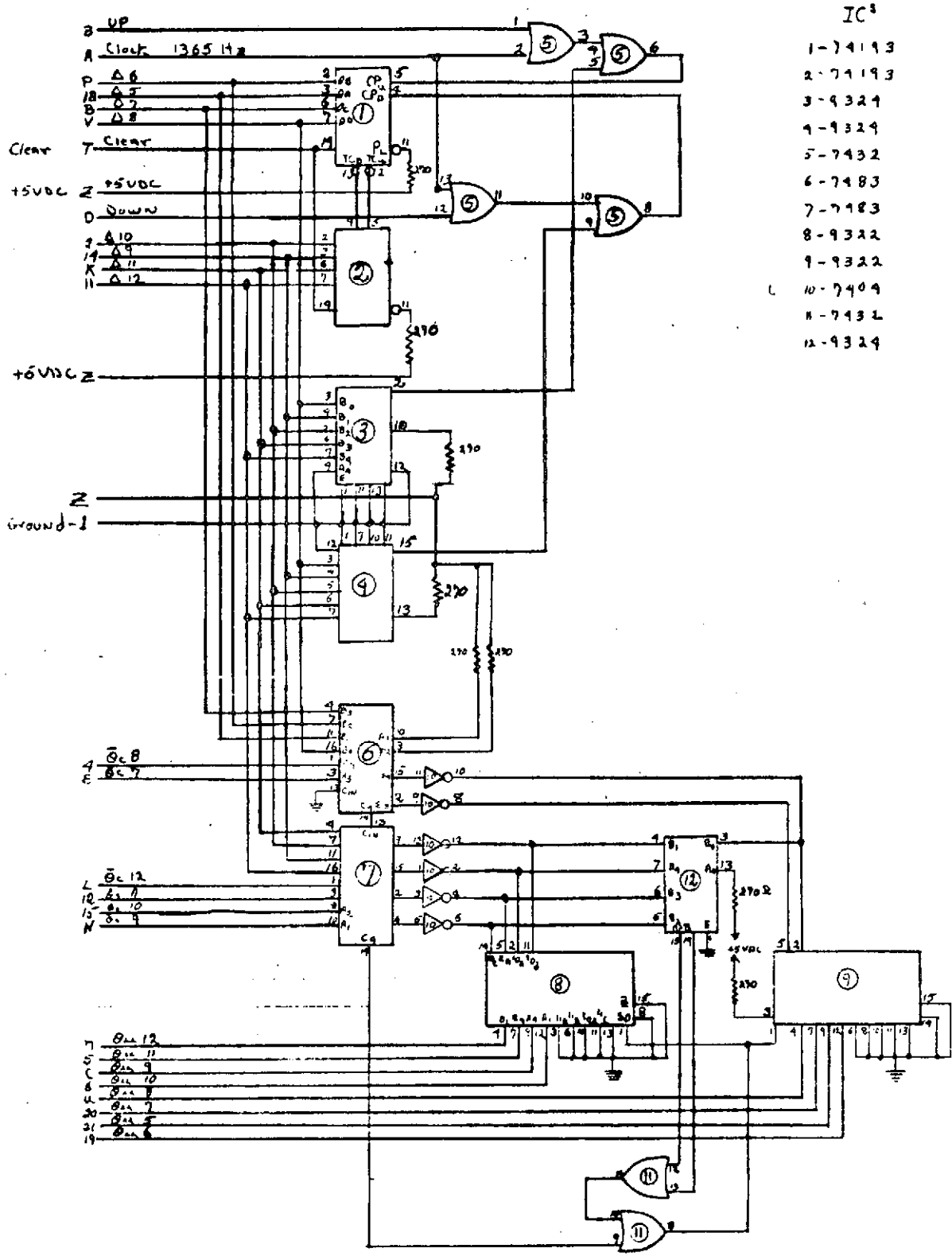

IC<sup>1</sup>

1	-74193
2	-74193
3	-9324
4	-9324
5	-7432
6	-7483
7	-7483
8	-9322
9	-9322
10	-7404
11	-7432
12	-9324

Fig. 9 - CE-7 (CR-7) Sector Scan Control

IC-3 (upper) and IC-4 (lower). The OR gates of IC-5 are connected as shown below.

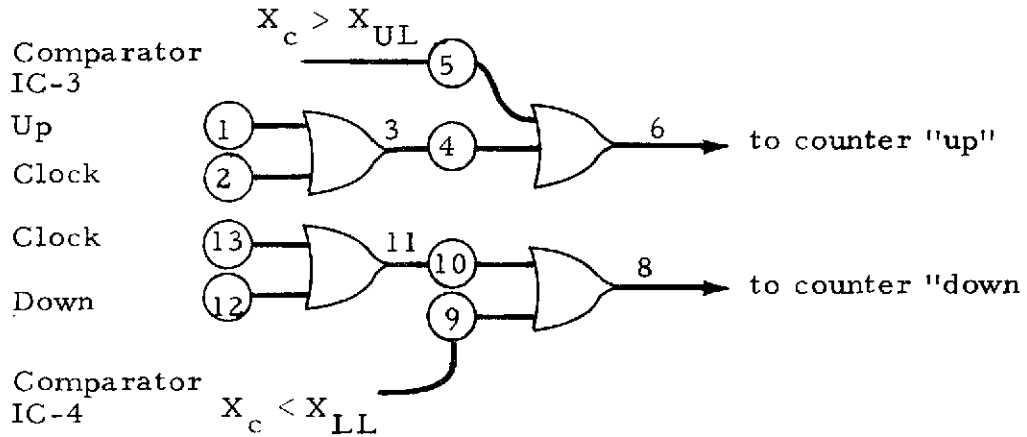

The slewing switch output is as shown in the following table:

Position	5-1	5-12	5-3	5-11	Action
Select up	Lo	Hi	Clock	Hi	Increases span
Select down	Hi	Lo	Hi	Clock	Decreases span
Hold	Hi	Hi	Hi	Hi	Constant at last value

The second pair of OR gates inhibits the clock from appearing on the "up" control whenever the upper limit has been exceeded, and inhibits the "down" clock whenever the counter output falls below the lower limit. These limits, appearing as hard-wire "high" inputs on IC3-10 (25.6 degrees) and IC4-13 (3.2 degrees), ensure that the sector span is neither too large nor too small.

To subtract the span from the center value and thus obtain the lower limit, we use the same algorithm as was described previously, i.e.,

$$X_{LL} = [X_{CL}^* + \Delta]^*$$

$X_{LL}$  = lower limit

$X_{CL}^*$  = complement of center position value

$\Delta$  = magnitude of half span

The complemented center line word,  $X_{CL}^*$ , is an input to board No. 7; it is generated on board No. 8. Note that we only use the top six bits of this, since it is derived from a 6-bit inverter (7404). This economizes on circuitry and provides sufficient accuracy. The summing is accomplished in the cascaded adder IC-6 and IC-7 (7483). The missing bit positions in  $X_{CL}^*$  are replaced by hardwire "high" values on pins 8 and 10 of IC-6 (these represent zeros in the uncomplemented word). Since we have no assurance that  $\Delta < X_{CL}^*$ , the carry-out on IC-7 pin 14, which goes high when the inequality is not satisfied, is used to perform some additional control which will be described shortly.

The complementation of the sum ( $X_{CL}^* + \Delta$ ) is accomplished in IC-10 (7404 inverter), applied to the top six bits. At this point we must note that we want to prevent  $X_{LL}$  from becoming too small, (we do not want the beam to become horizontal), and in addition, we may obtain a fictitious result from the subtraction algorithm when  $\Delta > X_{CL}^*$ , which may look to the comparator as an acceptably large value of  $X_{LL}$ . For these reasons we use an OR gate IC-11 (7432) to generate a high level when either a carry-out from the adder occurs, or when  $X_{LL}$  is less than the hard-wire limit on the comparator IC-12 (this is set equal to 1.6 degrees by a high on pin 13 of IC-12). This logical output is then used, in conjunction with the four-bit selectors IC-8 and IC-9, to select the subtraction result when the OR output is low, and a hard-wired value of 1.6 degrees when the OR output is high.

The clock input to this board has a fixed rate of 34 pps, which gives a reasonable expansion speed for the span variable,  $\Delta$ .

## 3.2.9 CE-8 (CR-8)

This board, which is also exclusively used for the sector scan mode, performs the following.

- a. Generation of an 8-bit word representing the value of the midpoint of the sector scan regime
- b. Complementing this (the top 6 bits only) to provide a needed input for board No. 7
- c. Sum the  $X_{CL}$  word with the half-span word,  $\Delta$  (generated on board No. 7) to create the upper limit,  $X_{LL}$ , and
- d. Restrict the value of the  $X_{LL}$  to desired limits.

The implementation (Fig. 10) is very similar to CE-7. The word representing  $X_{CL}$  is generated in the cascaded counters IC-9, IC-10 (74-193), and bounded above and below by the comparators IC-11 and IC-7 in conjunction with the OR gate on IC-5. The top limit is set at 57.6 degrees and the lower at 12.8 degrees (range limits in meters are the above values multiplied by 10), by hardwired high values on the appropriate pins of the comparators.

The summation with  $\Delta$  is accomplished with the 4-bit cascaded adders IC-1 and IC-2 (7483). Note that  $X_{CL}$  and  $\Delta$  are sufficiently bounded to prevent the sum from exceeding the 12-bit scale provided, and will always be  $> 0$ .

Complementation of  $X_{CL}$ , which is needed by board No. 7, is accomplished with the hex inverter IC-3 (7404). As before, this is applied only to the six most significant bits.

While  $X_{UL} = (X_{CL} + \Delta)$  will not reach an unacceptably small value, it may become larger than we wish — no particular harm is done if this happens, but it is desired to be able to slew the center line rapidly and restrict the upper limit to a region of interest rather than have it go all the way to its unrestricted value. This is accomplished by a second comparator IC-8, which uses the  $A < B$  output (here A is the hard-wired limit and B is the unrestricted value of  $X_{UL}$ ) to operate the selectors IC-4 and IC-6. If the

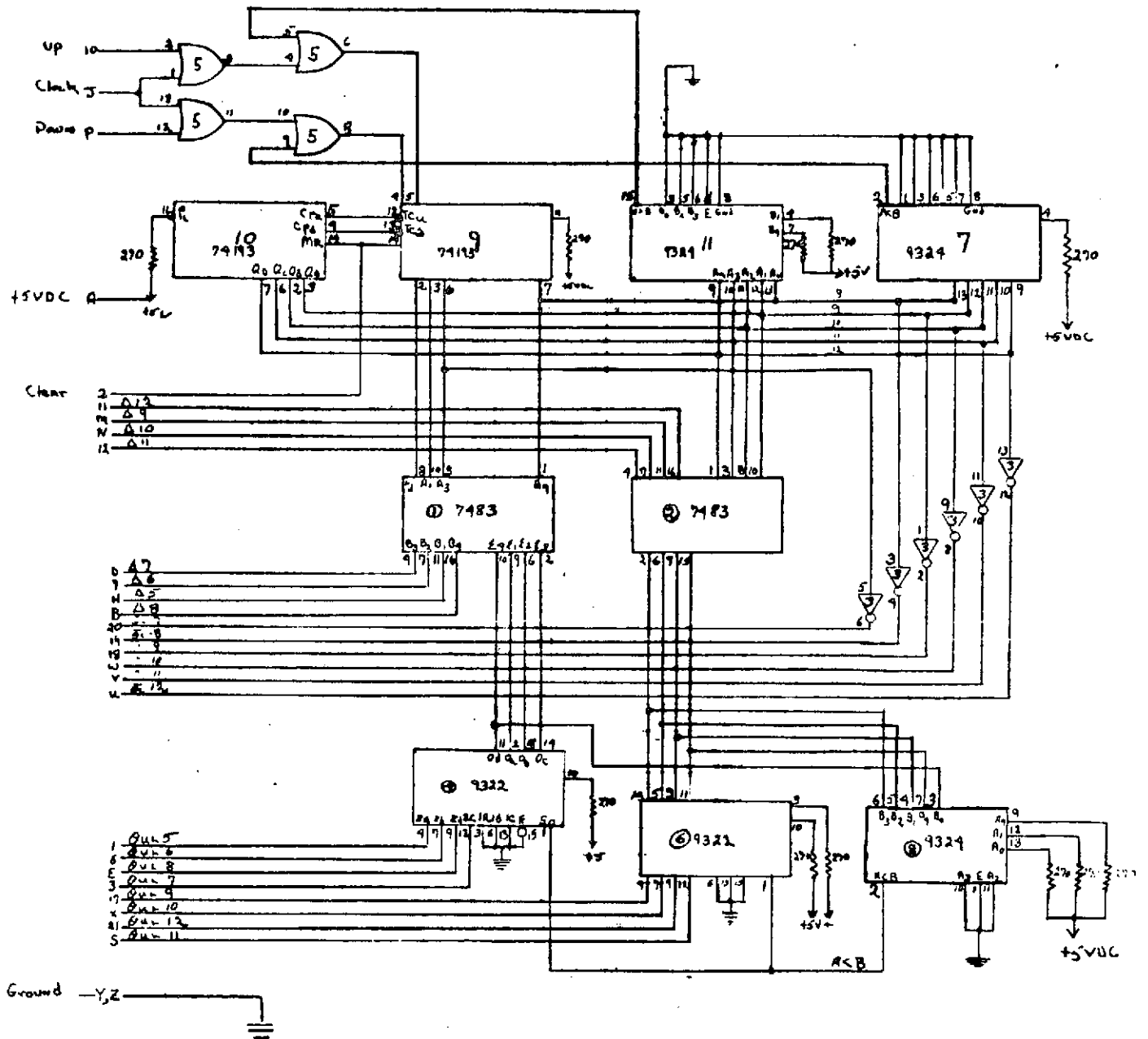

- IC<sup>s</sup>
- |          |            |
|----------|------------|
| 1 - 7483 | 9 - 74193  |
| 2 - 7483 | 10 - 74193 |
| 3 - 7404 |            |
| 4 - 9322 |            |
| 5 - 7432 |            |
| 6 - 9322 |            |
| 7 - 9324 |            |
| 8 - 7481 |            |

CE-8

Fig. 10 - CE-8 (CR-8) Sector Scan Control

inequality is false, the selected word is identical to  $X_{UL}$ , while if true,  $X_{UL}$  is replaced with a hard-wired word equal to the "A" word used for the comparison, which is 60.8 degrees (bit 12 (51.2 degrees) + bit 9 (6.4 degrees) + bit 8 (3.2 degrees)). It should be reiterated that the sector scan mode is merely another way of entering in upper and lower scan limits to the system, and has no effect which could not also be accomplished with the thumbwheels, although considerably more slowly if they were used.

### 3.2.10 CE-9 (CR-9)

This board accomplishes the following:<sup>\*</sup>

- a. In accordance with the front panel switch setting (normal or sector), selects the appropriate source of upper limit control word for the automatic mode.
- b. Selects, using the same switch output as in (a), the appropriate source of scan frequency control word.
- c. Multiplies the incoming clock frequency by a factor proportional to the selected scan frequency control word.

Function (a) is handled by the pair of 4-bit selectors (9322) IC-2 and IC-3, (only the most significant eight bits are used). This operation has already been described elsewhere and needs no additional comment. Since the scan frequency is separately controllable in the normal and sector mode, this must also be controlled by the mode selection switch; IC-1 (on CR-9) and IC-1 and IC-5 (on CR-9) perform this function. An additional selector is needed for range because this has a two decade control range, rather than one. In both modes, the source of the control word is a BCD coded thumbwheel switch (a pair of these for the range variable).

The multiplication of the clock frequency is accomplished by the rate multiplier IC-4 (74167) for elevation, and the cascaded pair IC-14, IC-6 for

---

\* See Fig. 11a.

Ground

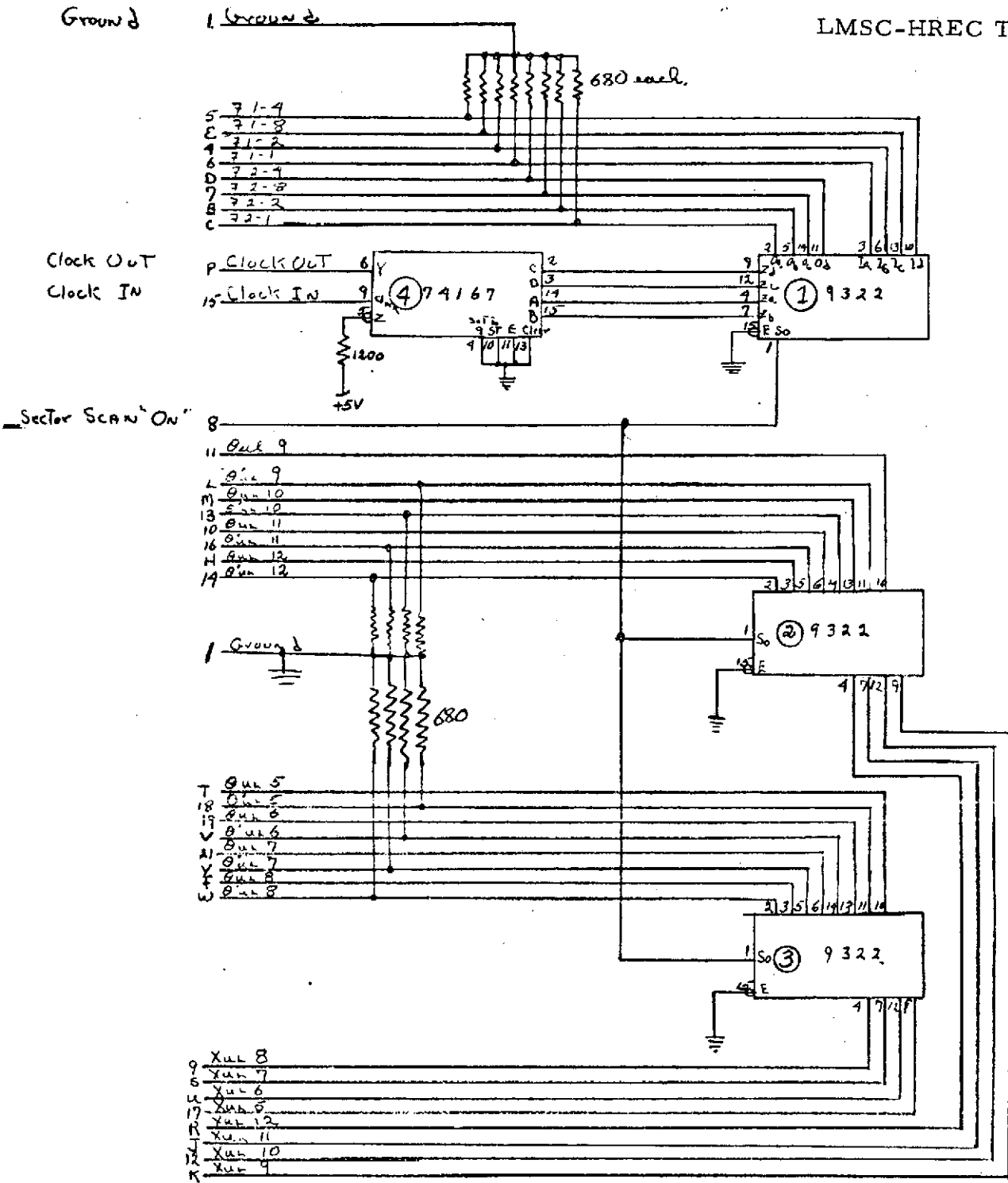

ICs

- 1-9322
- 2-9322
- 3-9322
- 4-74167

CE-9

Fig. 11a - CE-9 Mode Select and Rate Multiplier



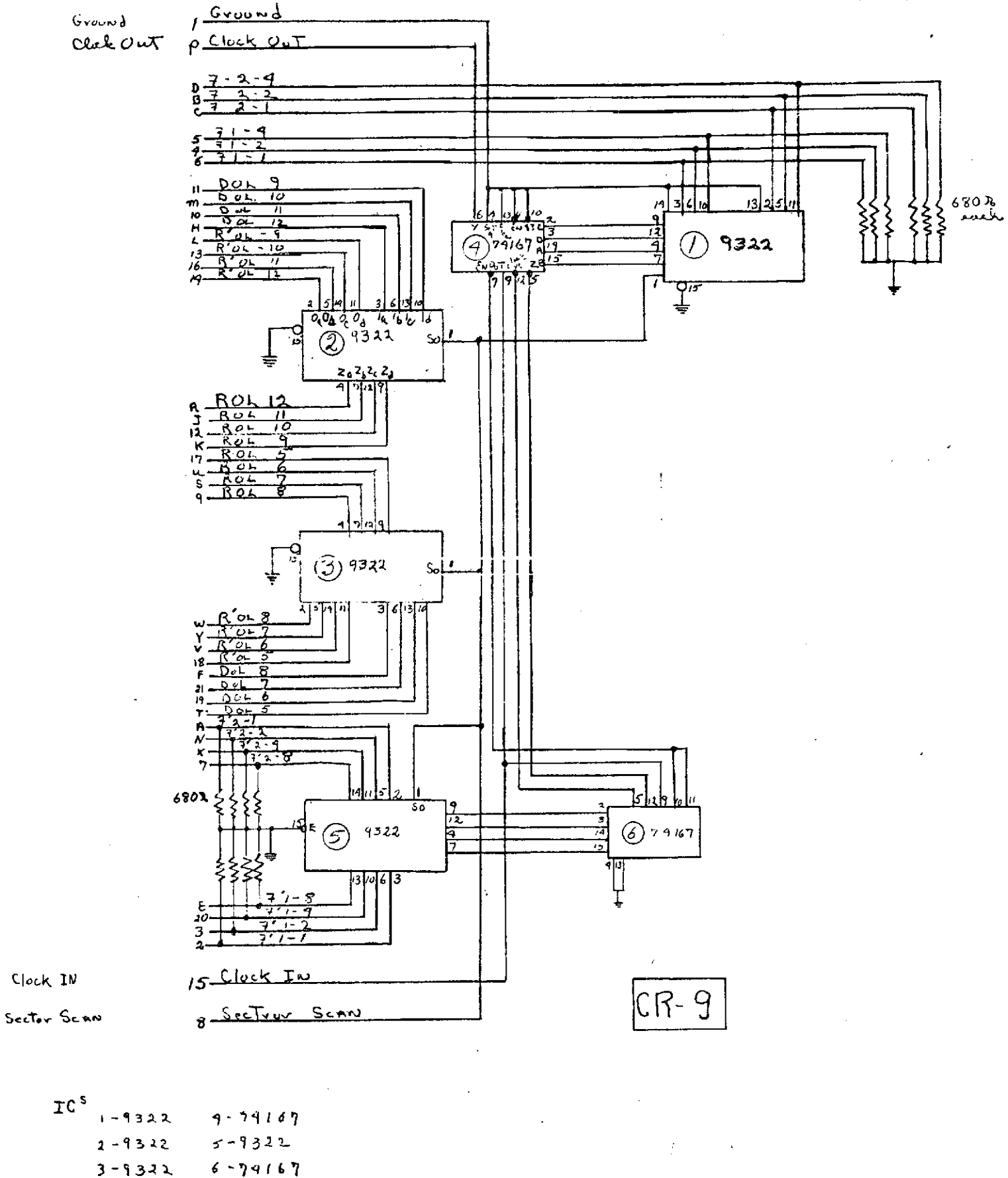

Fig. 11b - CR-9 Mode Select and Rate Multiplier

range (this feature makes these two boards non-interchangeable). The operation of the decimal rate multiplier should be clear from the previous description of the binary rate multiplier, the principal difference being the logical design needed to control the flip flops in accordance with an input BCD word. The output clock rate for a single IC is

$$f_{\text{out}} = \left[ \frac{2^3 \cdot D + 2^2 \cdot C + 2 \cdot B + A}{10} \right] \times f_{\text{in}} \quad (5)$$

where A, B, C, D have values zero or 1 in accordance with the input BCD (8-4-2-1) control word. When cascaded as shown in Fig. 11b, the output frequency is

$$f_{\text{out}} = \frac{10(2^3 \cdot D_1 + 2^2 \cdot C_1 + 2 \cdot B_1 + A_1) + (2^3 \cdot D_2 + 2^2 \cdot C_2 + 2 \cdot B_2 + A_2)}{100} \quad (6)$$

where  $A_i, B_i, C_i, D_i, i=1, 2$  are the binary states (0, 1) of the  $i^{\text{th}}$  input decade BCD code. As with the binary rate multipliers, the decade multipliers do not require a periodic input (although there are constraints on the minimal input clock inter-pulse spacing), and do not in general yield a strictly periodic clock pulse sequence on the output even if the input has this property.

A simple method for testing this board is to employ an input clock frequency which is a multiple of 100 (e.g., 100 kHz) and use a counter on the output to check the output frequency as a function of the control digits A, B, C, D.

### 3.2.11 Board CE-10 (CR-10)

This board shown in Fig. 12 performs two functions.

- a. To select, in accordance with the front panel mode select switch (normal/sector) one of two 12-bit words which serve as lower limit controls for the

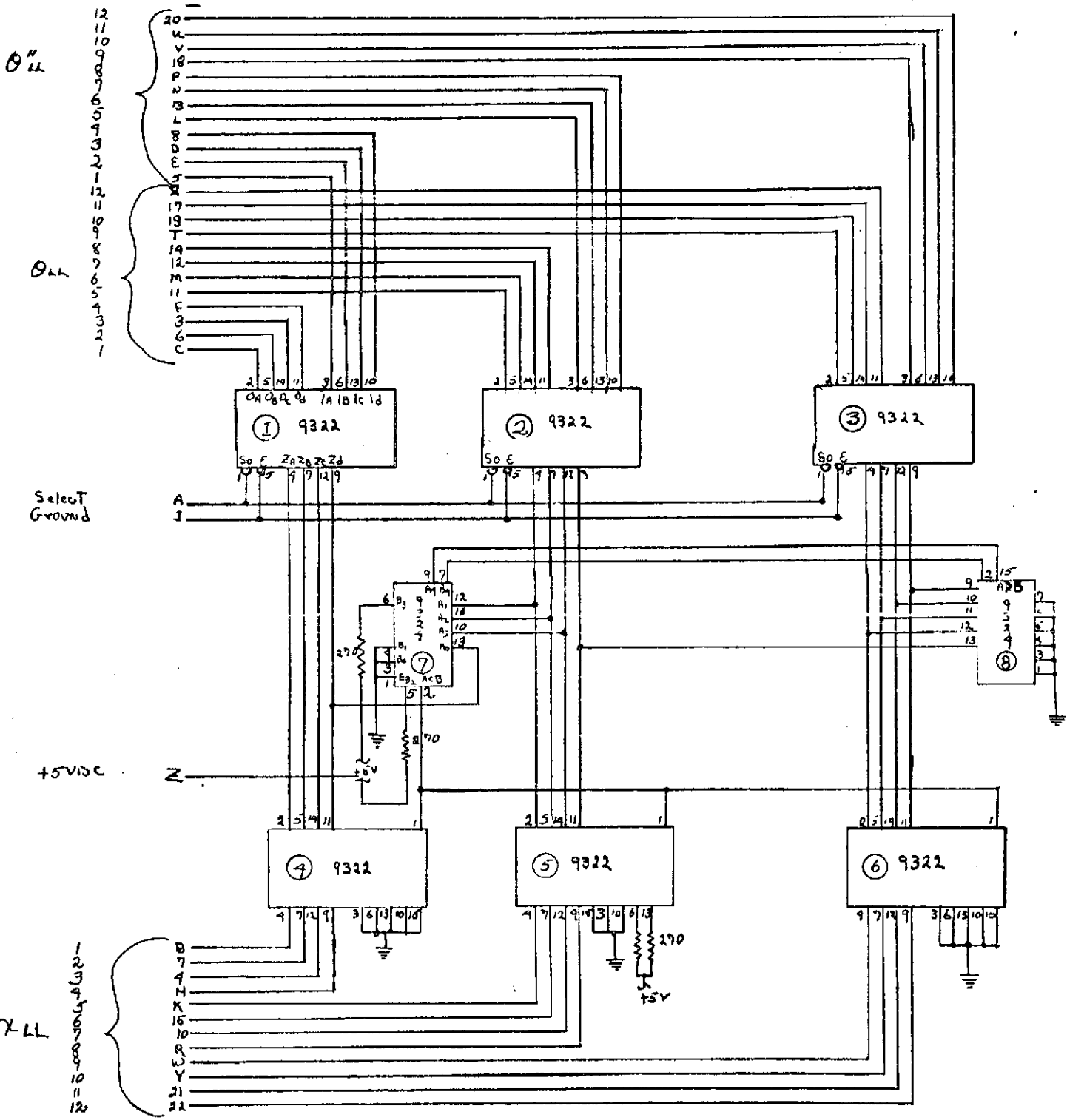

IC<sup>S</sup>  
 1-6 = 9322  
 7+8 = 9329

Fig. 12 - CE-10 (CR-10) Limit Select

CE-10  
 7.10

up/down counter on board No. 1. In one case (normal), the word selected is that generated on board No. 6, and in the other case (sector), the selected word is that generated on board No. 7. The selection is accomplished by the three 9322 ICs (Nos. 1, 2 and 3 on the drawing). The internal logic of these is such as to make the state of pins 4, 7, 12 and 9 (the outputs) identical to the states of pins 3, 6, 13 and 10, respectively, whenever a "high" state is on the select input (pin 1), and to make these outputs correspond to the states of pins 2, 5, 14 and 11, respectively, whenever the control the select input (pin 1) has a "low" state. In effect, the IC behaves as a four pole double throw switch. Since there is no cross coupling, the inputs need not have any particular ordering with respect to the magnitude represented in any 4-bit word. Each 9322 is used to select four bits of the 12-bit word.

b. The second function performed is that of preventing the selected word from becoming too small (we wish to prevent the lower limit from being too close to zero — in the range domain this would exceed the dynamic range of the range servo, and in the elevation domain we do this for safety reasons). This is accomplished by comparing the selected word with a "hardwired" (i.e., fixed) word having a magnitude of 3.2 degrees (in range 32 meters), and generating a logical "high" whenever the selected word is below this value. A cascaded pair of 9324s (ICs 7 and 8) implements this comparison; the "A" word input is the output of the first group of selectors, the "B" word is the hardwired word (in this case a single bit on pin 6 of IC 7 is high, and the remaining 8-bits low), and the  $A < B$  logical output appears on pin 2 of IC-7.

Since the comparator can only sense when  $A < B$  but cannot substitute B for A when this event occurs, another set of 9322 selectors (ICs 4, 5 and 6) is used to make this substitution. If  $A \geq B$ , then the selected lower limit from the first set of 9322s appears on the output; when  $A < B$ , then the hardwired "B" word is chosen. Since B is a fixed word, there is no need to reconnect all its constituent bits from the comparator to the output selector; we merely duplicate the B word at the output selector by grounding or pulling up to "high" level with a resistor the appropriate terminals.

### 3.3 ELEVATION SERVO

The schematic diagram of the elevation servo is shown in Fig. 13, and a functional block diagram is shown in Fig. 14. The subtraction necessary for the error signal is accomplished in a single op-amp IC ( $\mu A-725$ ), and the summation of the error signal and the damping signal is accomplished in the final power amplifier; the required gains  $G_1, G_2, G_3, G_4$  are obtained by appropriate choice of resistor values arranged in conventional feedback and summing configurations. The cascade consisting of  $F_1(s) \times G_5$  is obtained with two op-amps ( $\mu A-725$ ) and appropriate R-C networks. Feedback is provided by a precision (0.1%) potentiometer. The motor is a permanent magnet rotor, dc stator, restricted angle type

The overall transfer function of the servo has the form

$$\theta_{out}/\theta_{in} = \frac{G_1 K_0 G_3 K_m}{S^3 + C_1 S^2 + (C_2 + K_1 K_p K_m G_4 G_5) S + G_2 K_p G_3 K_m} \quad (7)$$

In order to have  $\theta_{out}/\theta_{in}$  in the static ( $S=0$ ) condition, we require

$$G_1 K_0 G_3 K_m = G_2 K_p G_3 K_m = \bar{K} \quad (8)$$

Let us also designate

$$\bar{C}_2 = C_2 + K_1 K_p K_m G_4 G_5 \quad (9)$$

and the transfer function can then be expressed as

$$\theta_{out}/\theta_{in} = \frac{\bar{K}}{S^3 + C_1 S^2 + \bar{C}_2 S + \bar{K}} \quad (10)$$

By appropriate choice of coefficients (note that while  $C_1$  and  $C_2$  are fixed, adjustments in the gains can realize a wide range of values for  $\bar{K}$  and  $\bar{C}_2$ )

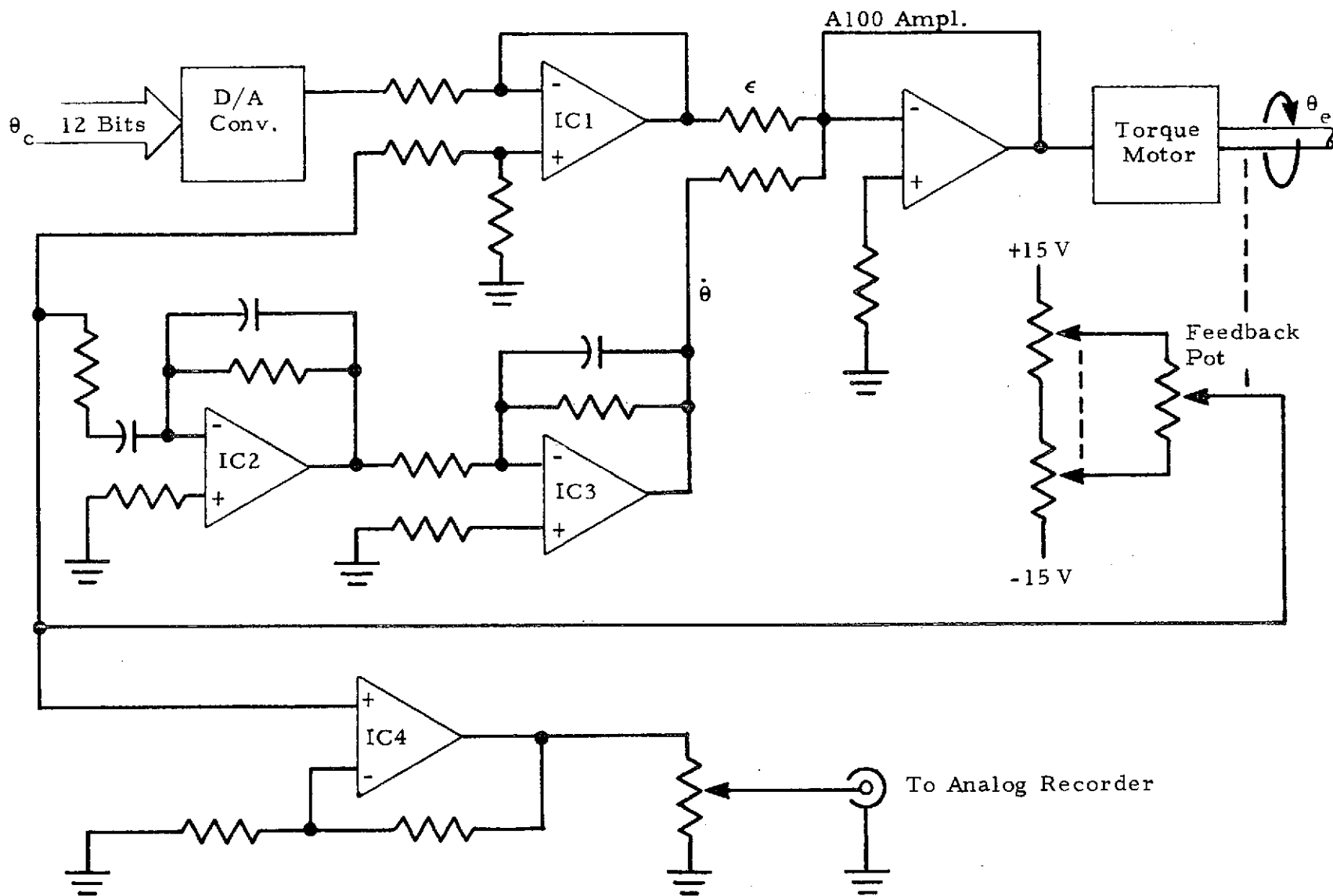

Fig. 13 - Elevation Servo Schematic

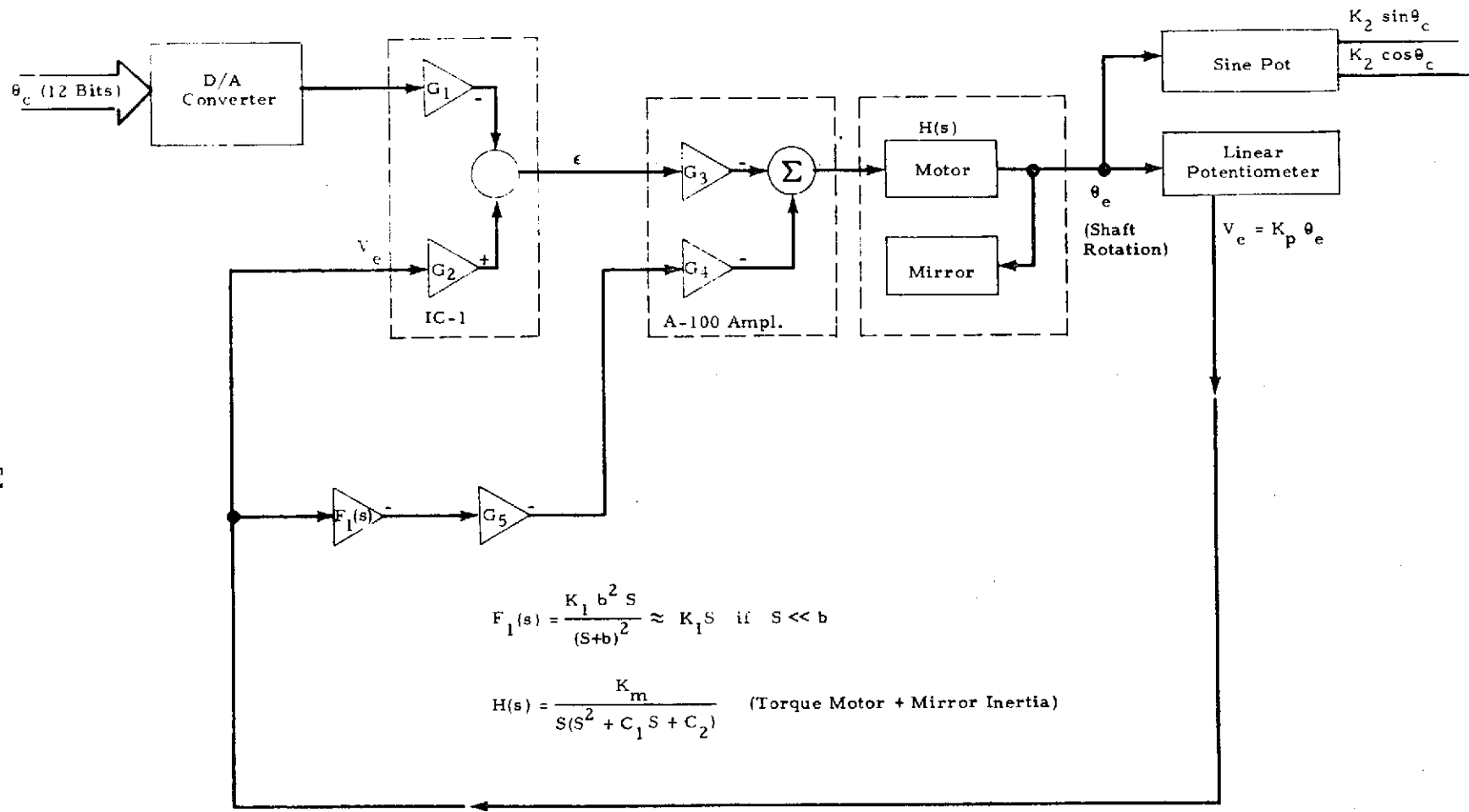

Fig. 14 - Elevation Servo Functional Diagram

we can achieve the performance desired. To determine the relation between performance and values of  $\bar{K}$  and  $\bar{C}_2$ , we express the polynomial in the denominator of Eq. (10) in the form

$$s^3 + C_1 s^2 + \bar{C}_2 s + \bar{K} = (s + a_0) \left[ (s + \alpha)^2 + \beta^2 \right] \quad (11)$$

where the first term indicates a real negative root and the second is a pair of complex conjugate roots. From Eq. (11), by equating coefficients of like powers of  $s$ , we have the relations

$$a_0(\alpha^2 + \beta^2) = \bar{K} \quad (12)$$

$$a_0 + 2\alpha = C_1 \quad (13)$$

$$2\alpha a_0 + (\alpha^2 + \beta^2) = \bar{C}_2 \quad (14)$$

designate

$$\omega_n^2 = (\alpha^2 + \beta^2) = \text{natural frequency} \quad (15)$$

Provided that  $a_0$  is not too small, the value of  $\omega_n$  is indicative of the servo bandwidth. In addition to realizing some desired bandwidth, we also want the system to be reasonably well damped, i.e., to respond to a step command without excessive "overshoots."

Designate

$$\xi^2 = \frac{\alpha^2}{\omega_n^2} \quad (16)$$

In general, if  $\xi \approx 1/2$  the step response will be reasonably fast and free from overshoots.



Substituting Eqs. (15), (16) and (13) into Eqs. (12) and (14) gives

$$\bar{K} = (C_1 - 2\xi \omega_n) \omega_n^2 \quad (17)$$

$$\bar{C}_2 = \omega_n^2 + (C_1 - 2\xi \omega_n) (2\xi \omega_n) \quad (18)$$

From Eqs. (17) and (18), the values required by  $\bar{K}$  and  $\bar{C}_2$  in order to obtain specified  $\omega_n$  and  $\xi$  can be determined. These equations must be used with some care, however, since we also have the relation

$$a_0 = (C_1 - 2\xi \omega_n) \quad (19)$$

It is evident that  $a_0$  will become very small if we attempt to realize very large values of  $\omega_n$ , and since the step response will contain a transient of the form  $e^{-a_0 t}$ , small values of  $a_0$  will yield a slow recovery time, i.e., an undesirable response, the actual values in the design are

$$\omega_n = 3.4 \text{ rad/sec}$$

$$\xi = 0.5$$

The reader will note that this is a rather small value of  $\omega_n$ . It should be pointed out, however, that the final amplifier has a maximum output voltage capability, resulting in an upper bound on the motor torque, and hence a limit on the acceleration available in the driven mirror. This torque limit will dominate the response speed, and hence set the "real" bandwidth. Attempts to obtain very large bandwidths by using large values of  $\bar{K}$  will simply cause torque saturation at smaller values of error.

One final remark is in order with respect to Eq. (10); the expression as given is in fact an approximation, since the  $F_1(s)$  function is actually more complicated, leading to a fifth order polynomial in the denominator. The exact expression, considering only the response to expected waveforms, does not differ significantly from Eq. (10). The additional high frequency cutoff

on the actual  $F_1(s)$  serves to reduce the high frequency noise which would otherwise appear on a time "differentiator," without adversely affecting the desired damping.

Parameter Summary:

$$G_1 = R_{11}/R_{10} = 2$$

$$G_2 = \left( \frac{R_{13} + R_{14}}{R_{12} + R_{13} + R_{14}} \right) \times \left( \frac{R_{10} + R_{11}}{R_{10}} \right) = 2.28$$

(note that  $G_3$  is adjustable with  $R_{14}$ ).

$$K_0 = 5.58 \text{ volts/radian}$$

$$K_p = 4.92 \text{ volts/radian}$$

$$K_0 G_1 = K_p G_2 = 11.2$$

$$K_m = 29 \text{ sec}^{-3} \text{ volts}^{-1}$$

$$C_1 = 167 \text{ sec}^{-1}$$

$$C_2 = 25.5 \text{ sec}^{-2}$$

} Fixed motor and load  
inertia parameters

$$G_3 = R_6/R_7 = 6$$

$$G_4 = R_6/R_8 = 6$$

$$G_5 = R_{18}/R_{18} = 18.8$$

$$K_1 = C_8 R_{16} = 3.3 \times 10^{-2} \text{ sec}$$

$$b = \frac{1}{C_9 R_{16}} = \frac{1}{C_8 R_{15}} = 30 \text{ sec}^{-1}$$

(Note:  $F_1(s) = \frac{K_1 b^2 S}{(S + b)^2} \approx K_1 S$  when  $S$  is small)

### 3.4 RANGE SERVO

The schematic of this servo is shown in Fig. 15, and a functional block diagram in Fig. 16. This servo differs from the elevation servo in several respects, the more important of which are the following:

a. The actual variable being controlled is the external location of the point of maximum intensity of the focused laser beam, which is not directly observable, and not accessible to provide feedback. It can be shown, however, that the location of this point is related to the position of the secondary mirror by the expression

$$r_f = \frac{F^2}{d_m} \quad (20)$$

where

- F = focal length of telescope optics
- $d_m$  = position of secondary mirror with respect to the focal point of the telescope mirror
- $r_f$  = location of external point of maximum beam intensity.

From Eq. (20) it is clear that if we have available a voltage representing (i.e., proportional to) the desired value of  $r_f$ , we must obtain the reciprocal of this in order to obtain the proper secondary mirror motion. This operation is accomplished by the first divider (AD1) shown in Fig. 15.

b. From Eq. (20) it is evident that when  $d_m$  is small, (i.e., when focused at long range), even very small errors in positioning the mirror will lead to very large errors in the position of the external focus, hence the feedback device which gives a voltage proportional to the mirror position must be extremely accurate. For this reason, the design employs a digital shaft encoder with 13 bits, which can determine the shaft angle to within  $\pm 0.08789$  degrees.

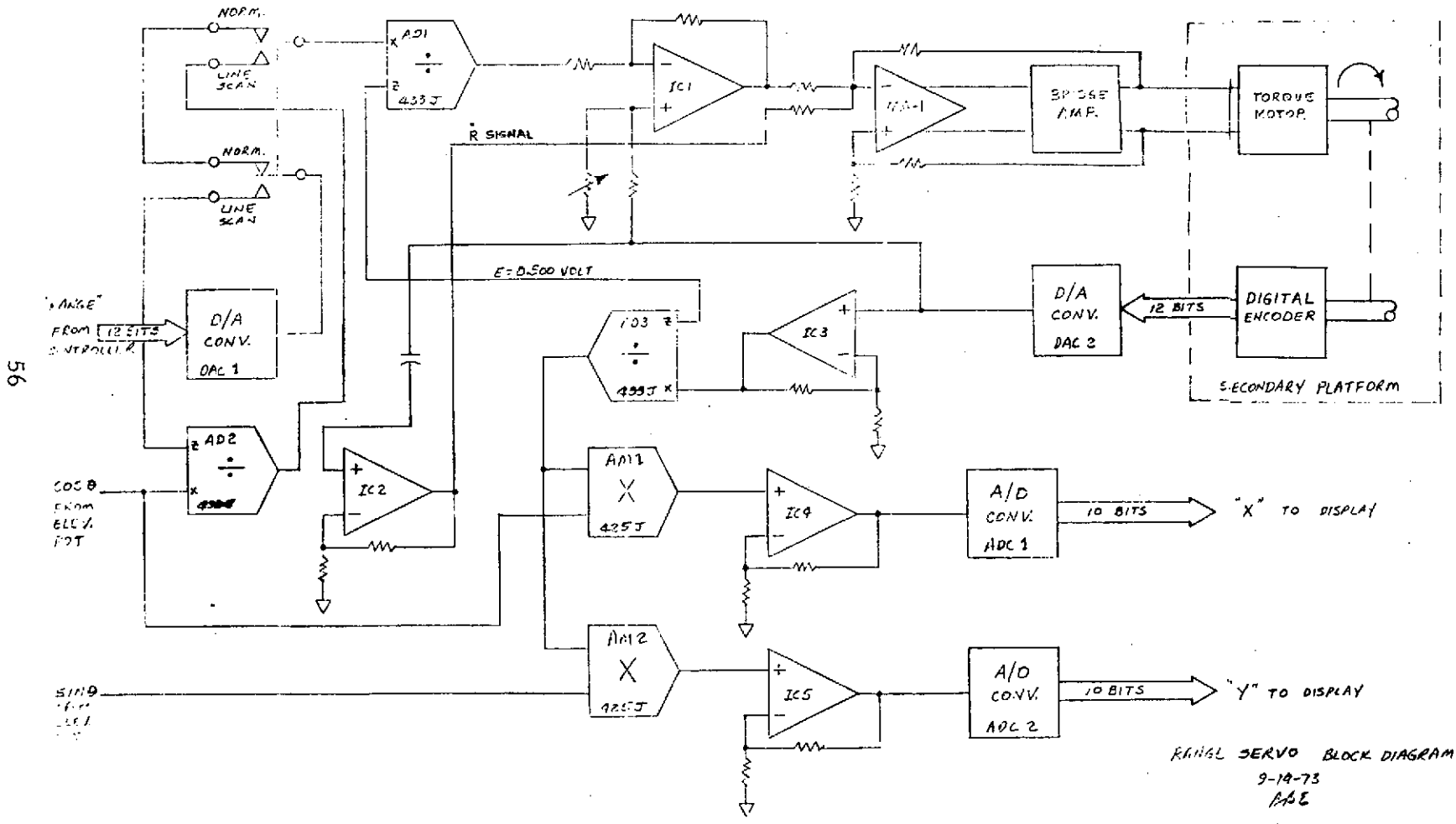

Fig. 15 - Range Servo Schematic

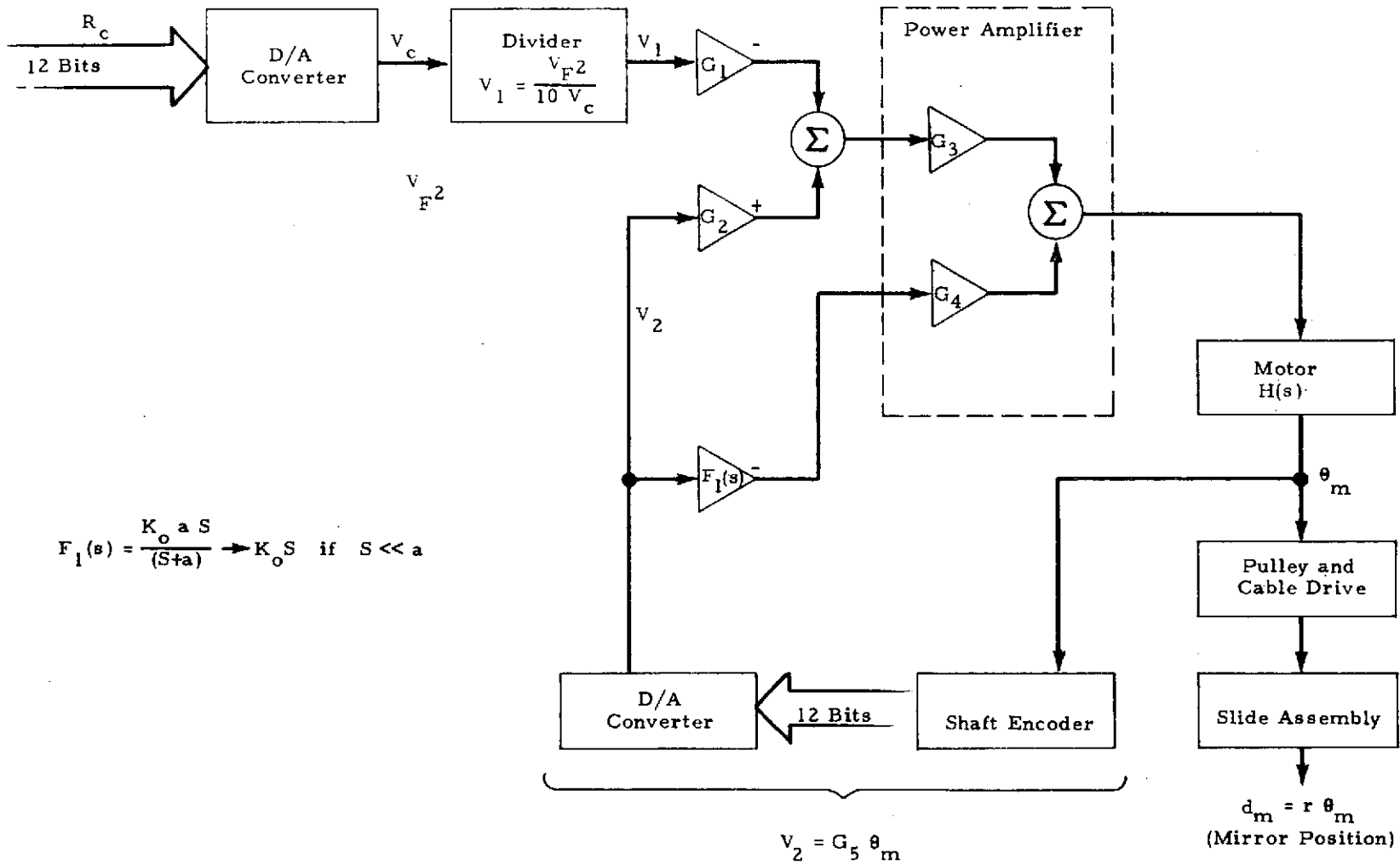

Fig. 16 - Range Servo Functional Diagram

The encoder shaft (to which is also attached the torque motor) is then coupled by a flexible\* cable and pulley to the horizontal slider mount of the secondary mirror.

c. Since the outputs (i.e., the location of the external focus) are required in x, y form rather than polar, these components must be derived. This is accomplished by multiplying  $r$  by the sine and cosine of the elevation angle. The trigonometric functions are provided by a sin/cos precision potentiometer on the elevation (mirror) shaft, and the multiplications performed by AM1 and AM2. The op-amps provide scale factors appropriate for the dynamic range of the multipliers.

Since the x, y outputs are required to be in digital form, a pair of A/D converters, ADC1 and ADC2, are incorporated, along with scale factor amplifiers. The converters are read-out by strobe pulses (provided by the signal processor) at a rate dependent upon the selected integration time.

It will be observed that the voltage representing  $r_f$ , which is used in the x, y multiplications, is not the input command, but is a reconstructed version based on the actual mirror position, i.e., making use of Eq. (20). This is done in order that the resulting x and y will not exhibit errors due to failure to follow the input command exactly (the rates of change of the  $1/r_c$  input command function are extremely high at short range, and the servo will not follow these exactly). The divider AD3 implements Eq. (20) to reconstruct  $r_f$ .

d. One of the operating modes (line scan) requires that the external focus move along a vertical line located at some selected value of horizontal range,  $R_h$ , as the scanner moves in elevation angle. In this case, the desired secondary mirror motion must follow the relation

$$d_m = \frac{F^2 \cos \theta_e}{R_h} \quad (21)$$

---

\*Flexible, but without stretch or slack.

This is accomplished by reconnecting the same divider normally used to obtain the function  $F^2/r_c$ ; in the line scan arrangement,  $r_c$  is replaced by  $R_h$  (the analog version of  $R_h$  is obtained from the same D/A converter normally used for  $r_c$  — the scan controller unit makes this replacement of input when the line scan mode is selected), and the  $\cos\theta$  voltage (properly scale factored with an op-amp) replaces the previously constant value of  $F^2$ . The remaining circuitry functions as before. Note that with this arrangement, the x component should be invariant with  $\theta_e$ , since  $R_h$  is constant, and the fact that this is so is a good check on the proper operation of the circuitry involved in reconstructing  $r_f$  and forming  $r_f \cos\theta_e$ .

e. That portion of the circuitry which moves the secondary mirror to follow the input  $F^2/r_c$  command, while having the same generic form of transfer function as the elevation servo (i.e., a constant numerator and a cubic denominator with one real root and a pair of complex conjugate roots) differs in the following particulars:

1. The natural frequency of the control loop is in the order of 40 times larger. This is necessary due to the (usually) higher input scan frequency and the higher order harmonic content generated by forming the reciprocal  $1/r_c$ .
2. Wide bandwidth is more easily achieved, since only small inertias are involved in the moving parts (the torque motor itself is the dominant source of the inertia term).
3. The damping compensation requires only one op-amp, since the inherent damping term ( $C_2$ ) is higher, and additional gain is obtained as part of the summing network in the final power amplifier.
4. The excursion in the controlled variable (secondary mirror position) required to cover the desired operating range is quite small ( $\approx 0.25$  in.), so that a high torque, small angle, torque motor can be used.
5. The feedback variable is generated in digital form, and so a D/A converter (DAC2) is needed. Because the "all-zero" output word must correspond to  $R = \infty$  when the mirror is at the focal point of the optical system, and because the mechanical linkage results in an increasing digital word in the direction interpreted by the system as corresponding to diminishing value of  $d_m$ , the digital word

is complemented (with two 6-bit inverters) in order to change sign before being converted to an analog voltage. Only the 12 lower bits of the 13-bit output are used, since the most significant bit is known to be constant throughout the operating range of the servo.

### System Parameters

#### 1. Transfer function

$$\frac{d_m}{V_1} = \frac{K_1}{S^3 + C_1 S + (C_2 + C_2') S + K_2} = \frac{K_1}{(S + a_0) [(S + \alpha)^2 + \beta^2]} \quad (22)$$

where

$$K_1 = rK_m G_1 G_3 = 5.7$$

$$K_2 = K_m G_2 G_3 G_5 = 2 \times 10^7$$

$$C_2' = K_m K_0 G_4 G_5 = 1.425 \times 10^5$$

$$r = 0.5 \text{ inch} \quad (\text{Cable drive pulley radius})$$

$$G_1 = 0.0475$$

$$G_2 = 0.261$$

$$C_2 = 2.26 \times 10^4$$

$$C_1 = 570$$

$$K_m = 1.89 \times 10^5$$

$$G_3 = 127$$

$$G_4 = 6$$

$$G_5 = 3.183 \text{ volts/radian (optical encoder and D/A converter)}$$

$$K_0 = 4 \times 10^{-2}$$

} Fixed motor/load parameters

These parameters yield the following values for the polynomial coefficients  $(S + a_0) [(S + \alpha)^2 + \beta^2]$



$$\begin{aligned}\omega_n &= (\alpha^2 + \beta^2)^{1/2} = 250 && \text{(natural frequency)} \\ a_0 &= 320 && \text{real root} \\ \xi &= \left( \frac{\alpha^2}{\alpha^2 + \beta^2} \right)^{1/2} = 0.5 && \text{damping coefficient}\end{aligned}$$

## 2. Scale Factors:

The steady state scale factor relation is

$$d_m/V_1 = K_1/K_2 = \frac{r G_1}{G_2 G_5} = 0.0285 \text{ in./volt} \quad (23)$$

The voltage  $V_1$ , which is the servo input, is derived from the input range command and the first divider, as follows.

Desired range =  $R$  (position of external focus)

$$V_c = K_R \cdot R \quad (24)$$

where  $K_R$  is the scale factor determined by the scale factor of the 12-bit range word (LSB = 0.25 meter) and the D/A converter (all 12 bits "high" = 10 volts output) which gives

$$K_R = 9.76 \text{ millivolts/meter}$$

The voltage  $V_c$  is applied to a divider which has the behavior

$$V_{out} = \frac{10 V_a}{V_b} \quad (25)$$

where  $V_b$  is the "divisor" and  $V_a$  the "dividend." In our connection of this device, we have

$$V_{out} = V_1 \quad \text{(servo input)} \quad (26a)$$

$$V_b = V_c \quad \text{(range command)} \quad (26b)$$

$$V_a = 0.5 \text{ volt} \quad \text{(a fixed constant — sometimes called } V_{F2}) \quad (26c)$$

Combining Eqs. (23), (24), (25) and (26) gives

$$d_m = \frac{(K_1/K_2) (V_a/K_R) (10)}{R} \quad \left( \begin{array}{l} R \text{ in meters} \\ d_m \text{ in inches} \end{array} \right) \quad (27)$$

The numerical value of the numerator of Eq. (27) is

$$(K_1/K_2 \cdot V_a/K_R \times 10) = 14.6$$

The known optical parameters give the expression

$$d_m = \frac{F^2}{R} = \frac{(24)^2}{R \times 39.4} = \frac{14.6}{R}$$

In the above we have expressed F in inches (F = 24 inches) and used the scale factor 1 meter = 39.4 inches. Thus the focusing scale factors have been correctly incorporated.

The scale factors involved in the range reconstruction and x, y conversion are:

a. Range reconstruction

$$V_{R'} = \frac{10 V_{F2}}{K_c V_2}$$

where

$V_2$  = feedback voltage from optical encoder D/A converter

$K_c$  = gain of scale factor amplifier = 5

b. Function potentiometers

$$V_{\cos} = K_p \cos \theta_{el} \quad K_p = 10$$

$$V_{\sin} = K_p \sin \theta_{el}$$

c. Multiplication for x, y

$$V_x = K_3 V_{\cos} V_{R'} \quad \text{where } K_3 = 0.145$$

$$V_y = K_3 V_{\sin} V_{R'}$$

d. Converters

The output A/D converters employ 10 bits and require a 10 volt input to create the "all-high" output word. In order to function properly with the signal processor, the least significant bit must satisfy

$$\text{LSB} \Rightarrow 5/8 \text{ meters}$$

which means that the inputs representing x or y must have scale factors of

$$V_{x,y} = 1/64 \text{ volt/meter} \quad \text{SF} = \frac{10}{(2^N - 1) (5/8)}$$

Neglecting the trigonometric functions (which are unity at full scale) the  $V_x$ ,  $V_y$  voltages are

$$V_{x,y} = \frac{10 K_3 K_p V_F^2 r}{K_c G_5 d_m}$$

since

$$d_m = \frac{F^2}{R \times 39.4} \quad \left\{ \begin{array}{l} F = \text{inches} \\ d = \text{inches} \\ R = \text{meters} \end{array} \right.$$

$$\frac{V_{x,y}}{R} = \frac{10 K_3 K_p V_F^2 r \times 39.4}{K_c G_5 F^2} = \frac{10 \times 0.145 \times 10 \times 0.5 \times 0.5 \times 39.4}{5 \times 3.183 \times (24)^2} = \frac{1}{64}$$

as required.

### 3.5 INTERFACE CIRCUITS

Interface circuits in the scanner system are divided into two categories: (1) those required for interfacing between various subassemblies of the scanner itself, and (2) those required for interfacing with other subsystems, such as the signal processor.

The only circuits falling into the first category not described elsewhere are those between the sine-cosine potentiometer (on the elevation servo) and the range unit. These circuits are contained in a small chassis box mounted to the side of the elevation servo mount. Figure 17 is a schematic of the circuit. Plus and minus 15V are supplied over the connecting cable from the range unit. The scale factors are such that the sine-cosine potentiometer requires plus and minus 10V excitation. Since the system operates only over 90 degrees of the potentiometer, only the +10V need be precisely set. A trimming potentiometer is provided for this adjustment. The remainder of the circuit consists of two voltage followers for buffering the sine and cosine outputs. These outputs are cabled to the range unit for use in deriving the X and Y coordinates for the display system.

The interface between the scanner system and the signal processor is described in Section 2.4. The X and Y coordinates are obtained by multiplying the "reconstructed" range voltage by the voltages representing  $\sin\theta$  and  $\cos\theta$ . This multiplication is carried out in the range unit by means of precision analog multipliers. The result of each multiplication ( $R \sin\theta$ ,  $R \cos\theta$ ) is buffered by an operational amplifier which provides the proper scale factor for a 10-bit analog-to-digital converter. The 10 bits representing each of these functions are made available at a connector on the rear of the range unit for use in the display section of the signal processor.

### 3.6 POWER SUPPLY

A simplified schematic of the main power supply is shown in Fig.18. Operation of the power supply is as follows.

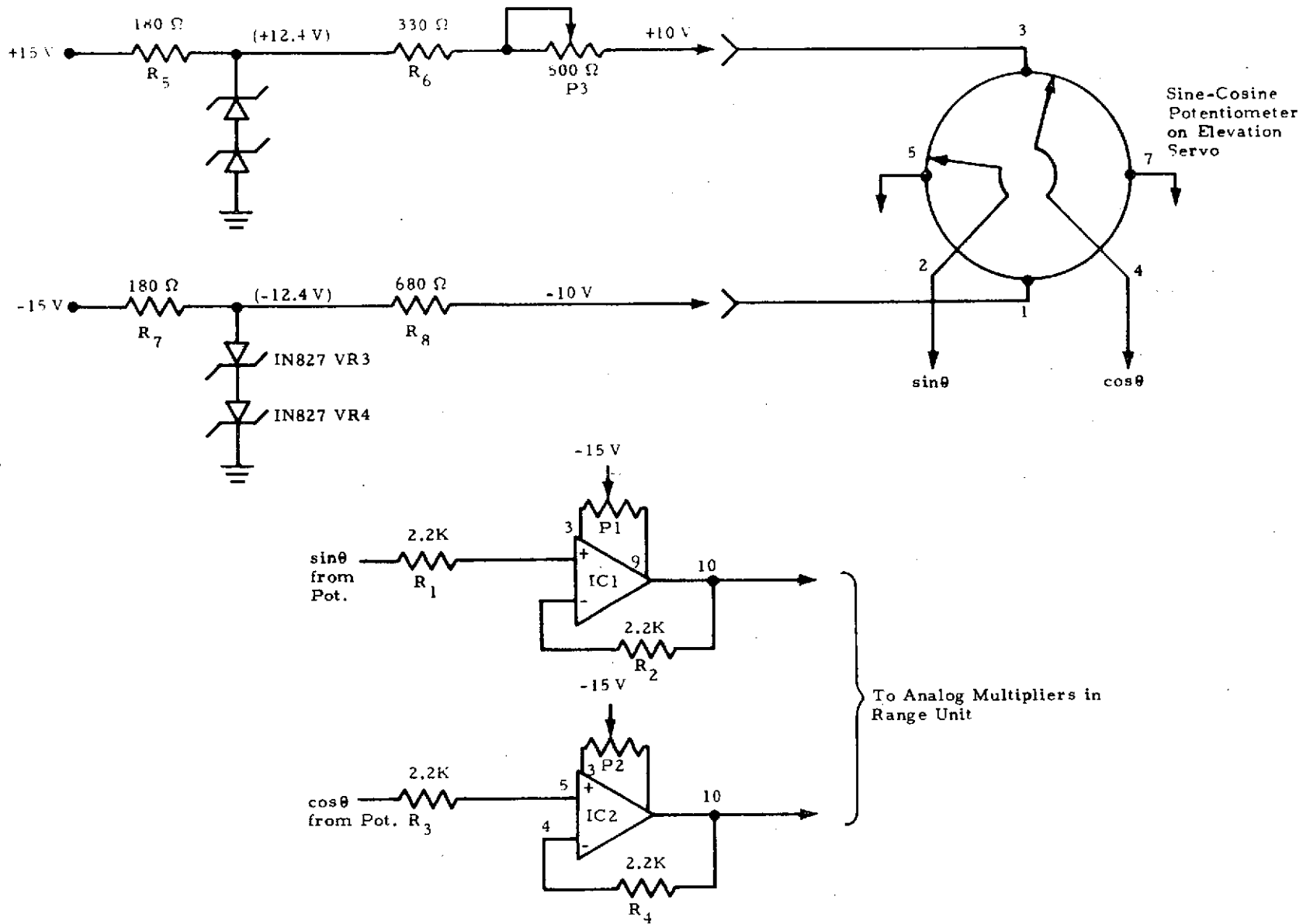

Fig. 17 - Range-Elevation Interface

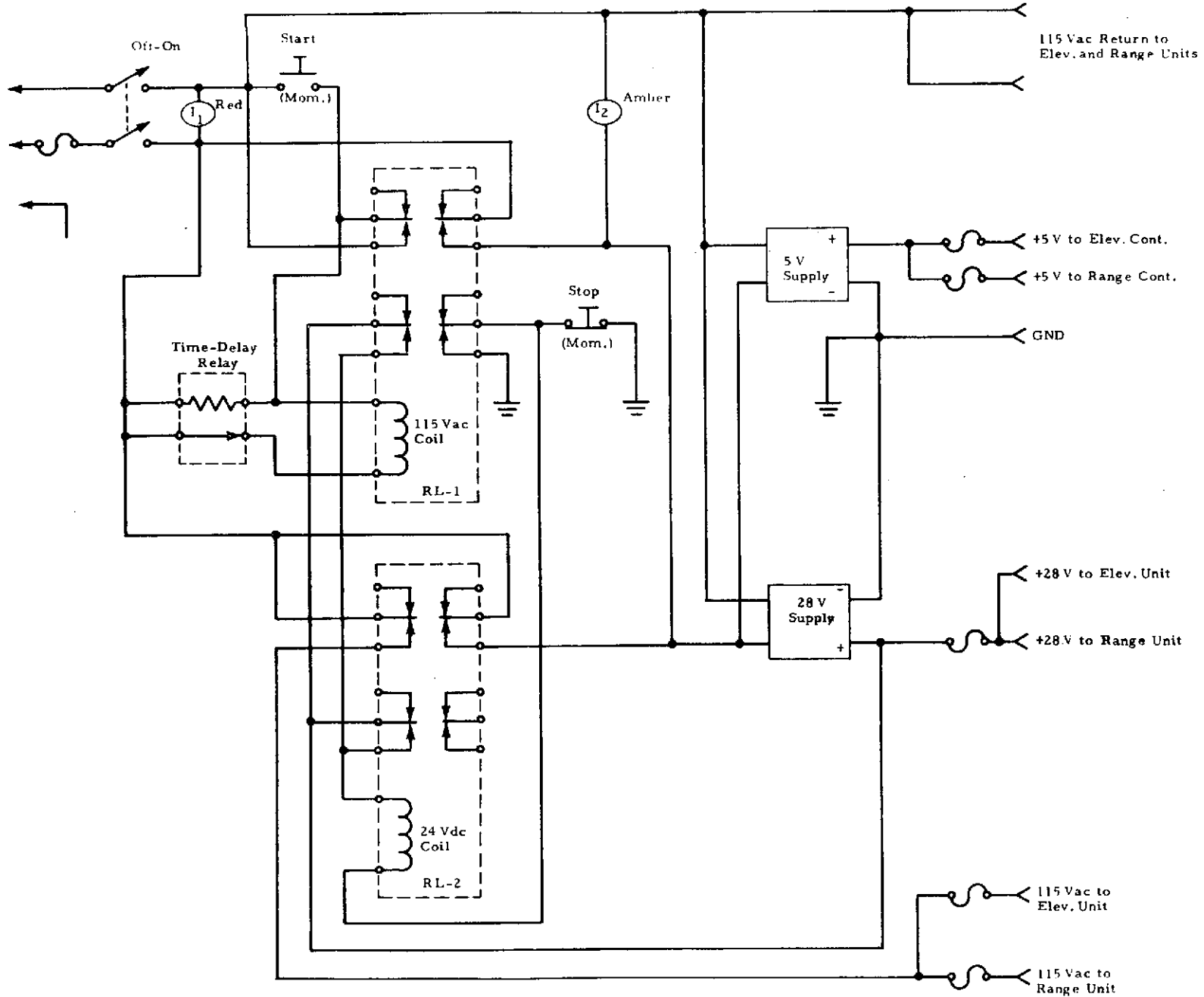

Fig. 18 - Power Supply

- a. The OFF-ON switch is placed in the ON position. This makes 115 Vac available to the unit and lights the red panel lamp to signify this condition.
- b. Depressing the START button applies 115 Vac momentarily to the coil of RL-1 which initially latches up. This action also starts the time-delay relay, whose contacts are normally closed and lights the amber panel lamp. After two seconds the time-delay relay contacts open, unlatching RL-1, which returns to its de-energized state, and can only be activated again by depressing the START button.
- c. While RL-1 is energized it does the following:
- Shorts out the STOP switch so that it has no effect
  - Applies 115 Vac to the 28 Vdc supply, permitting it to develop +28V at the output, and
  - Connects +28V output to the coil of RL-2 which will activate when the voltage reaches its pull-down value.
- d. When RL-2 is activated (which occurs before the time-delay relay contacts open) it does the following:
- Latches up RL-2 which remains activated even when RL-1 becomes de-energized
  - Applies 115 Vac to the range and elevation units
  - Applies 115 Vac to the +28 volt supply, so it continues to operate after RL-1 becomes de-energized, and
  - Keeps the amber panel lamp lit.
- e. When RL-1 resumes its de-energized state the STOP button can be depressed, breaking the ground return of the RL-2 coil, and removing power from the entire system. Power can also be removed from the system by placing the OFF-ON switch in the OFF position. In either case, power can only be restored by going through the above series of events.

## Section 4 SYSTEM TESTS

### 4.1 REQUIRED TEST EQUIPMENT

The following list represents the minimum test equipment required for initial adjustment and alignment of the scanner system, as well as that equipment required to ascertain proper operation of the system. Specific equipment manufacturers and model numbers are shown for reference only. Equivalent types may be substituted.

- a. Precision digital voltmeter capable of resolving tenths of millivolts – Datatek Model 350
- b. Medium-Speed Oscilloscope – Tektronix Model 561B
- c. Dual-Trace Plugin for b – Tektronix Model 3A6
- d. Time Base Plugin for b – Tektronix Model 3B3
- e. Two-Channel Stripchart Recorder – Brush Model 280
- f. X-Y Recorder – Hewlett Packard Model 7035B
- g. Digital Frequency Synthesizer – Monsanto Model 3100A
- h. Digital Counter – Hewlett Packard Model 5325A
- i. Plugin Card Tester – Lockheed (no part number)
- j. Digital Test Box – Lockheed (no part number)

### 4.2 INITIAL ADJUSTMENTS AND ALIGNMENT

The initial adjustments required for the scanner system are concerned with setting all amplifier offsets to zero, setting all D/A converter offsets to zero, and adjusting the gain of all D/A converters to the correct value.

Initial alignment of the scanner system consists of mechanically positioning the mirrors so that the servo systems are calibrated. This calibration requires operation of the scanner with the laser beam illuminating a Doppler wheel target.



## 4.2.1 Elevation Servo Chassis

Initial adjustment of the elevation servo chassis proceeds as follows.

- a. Connect the system power supply to the elevation servo chassis by means of the system power cable and apply power to the unit. Do not connect any other cables at this time.
- b. Insert test plug number 1 into receptacle JE1. This test plug is made up by shorting pins 1 through 12 to pin 13 (ground).
- c. Insert test plug number 2 into receptacle JE2. This test plug is made up by shorting pin 5 to pin 13 (ground).
- d. With the precision digital voltmeter monitor the dc voltage between pin U of card E2 and ground. This pin is the output of the D/A converter. Adjust the ZERO trimming potentiometer on card E2 until the indicated voltage is zero.
- e. Remove the test plug from receptacle JE1. The indicated voltage should be +10 volts. If the voltage differs from +10 volts, adjust the GAIN trimming potentiometer on card E2 until the meter indicates +9.9976 to +10 volts. The D/A converter is now set up for normal operation.
- f. Insert the test plug back into receptacle JE1. Monitor the voltage at pin 10 of IC1 on card E1. The voltage should be zero volts. If not, adjust trimming potentiometer R1 on card E1 until the voltage reads zero volts.
- g. Move the voltmeter probe to pin 10 of IC2 on card E1. If the voltage is not zero, adjust trimming potentiometer R2 on card E1 until the meter reads zero volts.
- h. Move the voltmeter probe to pin 10 of IC3 on card E1. Adjust trimming potentiometer R3 on card E1 until the meter reads zero volts.
- i. Move the voltmeter probe to pin 10 of IC4 on card E1. Adjust trimming potentiometer R21 until the meter reads zero volts.
- j. Remove the top cover of the AM100A servo power amplifier. With an insulated screwdriver adjust the current limit potentiometers to their full counter-clockwise position. This sets the amplifier output current to its maximum value. The location of these potentiometers is shown on the decal inside the top cover.
- k. Monitor the voltage between terminals 4 and 5 on the power amplifier with the digital voltmeter. CAUTION: 115 Vac is present on this terminal strip. Adjust the center potentiometer as shown in the decal for minimum voltage across terminals 4 and 5.

1. Turn off the power to the unit. Replace the top cover of the servo amplifier and remove the test plugs from JE1 and JE2. This completes the initial adjustments on the elevation servo chassis.

#### 4.2.2 Range Servo Chassis

Initial adjustment of the range servo chassis proceeds as follows:

- a. Connect the system power supply to the range servo chassis by means of the system power cable and apply power to the unit. Do not connect any other cables at this time.
- b. Insert test plug number 1 into receptacle JR1. This test plug is made up by shorting pins 1 through 12 to pin 13 (ground).
- c. With the precision digital voltmeter monitor the dc voltage between pin U of card R4 and ground. This pin is the output of the command D/A converter. Adjust the ZERO trimming potentiometer on card R4 until the indicated voltage is zero.
- d. Remove the test plug from receptacle JR1. The indicated voltage should be +10 volts. If the voltage differs from +10 volts, adjust the GAIN trimming potentiometer on Card R4 until the meter indicates +9.9976 to +10 volts. The command D/A converter is now set up for normal operation.
- e. With the precision digital voltmeter monitor the dc voltage between pin U of card R3 and ground. There should be no connection made to receptacle JR2. Adjust the ZERO trimming potentiometer on card R3 until the indicated voltage is zero.
- f. Insert test plug number 3 into receptacle JR2. This test plug is made up by shorting pins 1 through 12, 27 and 28 to pin 16 (ground).
- g. The indicated voltage at pin U of card R3 should be +10 volts. If the voltage differs from +10 volts, adjust the GAIN trimming potentiometer on card R3 until the meter indicates +9.9976 to +10 volts. The feedback D/A converter is now set up for normal operation.
- h. Turn off the power to the unit and remove module AD1 from its socket on card R7. With a clip lead short pin 2 of this socket to ground.
- i. Apply power to the unit and remove the test plug from receptacle JR2. Monitor the voltage at pin 10 of IC1 on card R7. Adjust trimming potentiometer P1 on card R7 until the meter indicates zero volts.

- j. Move the voltmeter probe to pin 10 of IC2 on card R7. Adjust trimming potentiometer P2 on card R7 until the meter indicates zero volts.
- k. Move the voltmeter probe to pin 10 of IC3 on card R7. Adjust trimming potentiometer P3 on card R7 until the meter indicates zero volts.
- l. Move the voltmeter probe to pin 10 of IC6 on card R7. Adjust trimming potentiometer P6 on card R7 until the meter indicates zero volts.
- m. Turn off the power to the unit, remove the clip lead from the socket of module AD1, and replace the module in the socket.
- n. Remove module AD3 from its socket on card R7. With a clip lead short pin 2 of this socket to ground. Insert test plug number 3 into receptacle JR2.
- o. Apply power to the unit. Allow 5 minutes for warm-up before proceeding to the next step.
- p. Monitor the voltage at pin H of card R1. Adjust the OFFSET trimming potentiometer (R1) on card R1 to obtain a meter reading of zero volts.
- q. Move the voltmeter probe to pin H of card R2. Adjust the OFFSET trimming potentiometer (R1) on card R2 to obtain a meter reading of zero volts.
- r. Move the voltmeter probe to pin 10 of IC4 on card R7. Adjust trimming potentiometer P4 on card R7 to obtain a meter reading of zero volts.
- s. Move the voltmeter probe to pin 10 of IC5 on card R7. Adjust trimming potentiometer P5 on card R7 to obtain a meter reading of zero volts.
- t. Turn off the power to the unit, remove the clip lead from the socket of module AD3, and replace the module in the socket. Remove the test plugs from receptacles JR1 and JR2. This completes the initial adjustments on the range servo chassis.

#### 4.2.3 Interface Circuits

Initial adjustments are required to set the amplifier offsets to zero for the interface circuits contained in the small chassis box on the elevation servo mount. There is also an adjustment in this box for setting the excitation voltage for the sine-cosine potentiometer. The following procedure describes these adjustments.

- a. Remove the cover from the small chassis box on the elevation servo mount.
- b. Connect all system cables to the proper receptacles. Ascertain that the servo loop switches are open on the main front panel.
- c. Apply power to the system and lock the elevation servo at zero as indicated by the elevation LED readout.
- d. With the precision digital voltmeter monitor the dc voltage between terminal 3 on the sine-cosine potentiometer and ground. Adjust trimming potentiometer P3 inside the small chassis box until the voltage reads +10 volts.
- e. Set the elevation mirror to zero as indicated by the vernier scale on the mirror mount shaft.
- f. Move the voltmeter probe to terminal 2 on the sine-cosine potentiometer. Loosen the potentiometer mounting screws and manually adjust the potentiometer to achieve a minimum reading on the meter. This voltage should be positive in sense and on the order of a few millivolts. Tighten the potentiometer mounting screws while preserving the position of minimum voltage.
- g. Move the voltmeter probe to pin 10 of IC1 inside the small chassis box. Adjust trimming potentiometer P1 inside the box until the meter reading is the same as in step f above.
- h. Set the elevation mirror to 90 degrees as indicated by the vernier scale on the shaft.
- i. Move the voltmeter probe to pin 4 on the sine-cosine potentiometer and verify that the voltage is a minimum.
- j. Move the voltmeter probe to pin 10 of IC2 inside the small chassis box until the meter reading is the same as in step i above.
- k. Repeat steps e through j until the minimum meter readings are consistently as near zero as possible.
- l. Replace the cover on the small chassis box and set the elevation mirror to zero as indicated by the vernier scale.
- m. Move the voltmeter probe to the wiper pin of the linear potentiometer. This is the front section of the potentiometer.
- n. Adjust the centering potentiometer located on the rear of the elevation servo chassis until the meter reading is a minimum.

This concludes the initial adjustments and alignment of the scanner system, with the exception of the A/D converters that interface with the processor. These converters require special test equipment. If a converter becomes suspect it should be replaced, and the suspect unit returned to the laboratory for checkout.

### 4.3 ELEVATION CONTROLLER TESTS

#### 4.3.1 Automatic Mode

##### 4.3.1.1 Upper Scan Limit Set

For test purposes the scan limit is defined as being the angle determined by the voltage output of the digital-to-analog converter for the command word when the latter voltage is at its maximum positive value. The maximum angle is given by:

$$\theta_{\max} = 10.24 V_{\max} \text{ (deg)} \quad (28)$$

The value of  $\theta_{\max}$  as given by Eq.(28) shall be functionally related to the angle set in on the upper limit thumbwheel in accordance with Table 2. (Table 1 gives the effect of the 5-bit truncation used in the comparator.)

##### 4.3.1.2 Automatic Mode – Lower Scan Limit Set

For test purposes the scan limit is defined as being the angle determined by the voltage output of the command word digital-to-analog converter when the latter is at its minimum value. The minimum angle is given by

$$\theta_{\min} = 10.24 V_{\min} \text{ (deg)} \quad (29)$$

The value of  $\theta_{\min}$  as given by Eq. (29) shall be functionally related to the lower limit thumbwheel setting as given in Table 3.

##### 4.3.1.3 Limit Tests and Procedures – Automatic Mode

Test 1 –

The output of the command word digital-to-analog converter shall be connected to a calibrated stripchart recorder with a convenient scale factor.

Table 2  
ELEVATION SCAN, UPPER LIMIT

Actual Scan Upper Limit (Digital)	Angle Value ( $\theta_{max}$ )	Thumbwheel Setting (Upper Limit)	
10010	57.6	59, 58	Note 1
10001	54.4	57, 56, 55	
10000	51.2	54, 53, 52	
01111	48.0	51, 50, 49, 48	
01110	44.8	47, 46, 45	
01101	41.6	44, 43, 42	
01100	38.4	41, 40, 39	
01011	35.2	38, 37, 36	
01010	32.0	35, 34, 33, 32	
01001	28.8	31, 30, 29	
01000	25.6	28, 27, 26	
00111	22.4	25, 24, 23	
00110	19.2	22, 21, 20	
00101	16.0	19, 18, 17, 16	
00100	12.8	15, 14, 13	
00011	9.6	12, 11, 10	Note 2

Note 1: Mechanical stops limit thumbwheel to 59 deg maximum.

Note 2: Mechanical stops limit thumbwheel to 10 deg minimum.

Table 3  
ELEVATION SCAN, LOWER LIMIT

Actual Scan Lower Limit (Digital)	Angle Value ( $\theta_{min}$ )	Thumbwheel Setting (Lower Limit)
01111	41.175	49, 48 <span style="float: right;">Note 1</span>
01110	47.975	47, 46, 45
01101	44.775	44, 43, 42
01100	41.575	41, 40, 39
01011	38.375	38, 37, 36
01010	35.175	35, 34, 33, 32
01001	31.975	31, 30, 29
01000	28.775	28, 27, 26
00111	25.575	25, 24, 23
00110	22.375	22, 21, 20
00101	19.175	19, 18, 17, 16
00100	15.975	15, 14, 13
00011	12.775	12, 11, 10
00010	9.575	9, 8, 7
00001	6.375	6, 5, 4
00000	3.175	3 or smaller

Note 1: Table applies so long as the difference between upper and lower limits on the thumbwheels is at least 10 deg; if not then

$$\theta_{LL} = \theta_{UL} - 9.6 \text{ deg}$$

which is accomplished automatically.

The control settings should be as follows:

Mode:	Automatic, normal
Frequency:	0.1 Hz
Lower Limit:	0 deg

Starting at 10 deg the upper limit shall be increased manually by 5 deg at the completion of at least one complete scan cycle. The values of  $\theta_{\max}$  as read from the recorder data (using Eq. (28)) shall conform to Table 2 within  $\pm 2$  deg.

#### Test 2 -

Using the same test setup, the controls should be set as follows:

Mode:	Automatic, normal
Frequency:	0.1 Hz
Upper Limit:	59 deg

Starting at 0 deg, the lower limit should be increased manually by 5 deg at the completion of at least one scan cycle. The values of  $\theta_{\min}$  should conform to Table 3 to  $\pm 2$  deg. (Note: The difference between upper and lower limits should not be made less than 10 deg.)

#### Test 3 - Scan Frequency

Mode:	Automatic, normal
-------	-------------------

For each of the conditions given in Table 4, manually program the scan frequency through the five available values, and determine the scan frequency from the stripchart recording, using time calibration marks or known chart speed. The frequency should correspond to the dial setting to within  $\pm 10\%$ .



Table 4  
SCANNING VALUES

Test Condition	Upper Limit (deg)	Lower Limit (deg)	Span (deg)	Center (deg)
1	59	44	15	51.5
2	39	24	15	31.5
3	19	4	15	11.5
4	59	29	30	44.0
5	34	4	30	19.0
6	59	9	50	25.0

Test 4 - Crossover

Control Settings: Automatic, Manual  
Frequency: 0.1 Hz

With the same test setup, set the upper limit successively to 20, 40, 59 deg. At each setting, move the lower limit toward the upper limit; the lower limit on the thumbwheel should be automatically replaced by  $\theta_{UL} - 9.6$  deg whenever the difference is less than 10 deg.

4.3.2 Manual Mode

The command voltage should be recorder monitored as in the previous tests.

Test 5 -

Depression of the up/down slewing switches should produce monotone variation at the command voltage between the limits of 89.6 deg and 3.2 deg,

in the selected direction. The indicated readout angle should correspond to the chart recording to within  $\pm 0.5$  deg. The slew speeds should be 34 deg/sec and 3.4 deg/sec to within  $\pm 10\%$ .

Depression of the single increment button, when the speed setting is "fast," should enable single increments of no greater than 0.2 deg in either selected direction.

#### 4.3.3 Sector Scan Mode

Tests of this mode shall employ the same recorder test setup as in the previous tests.

Mode:	Automatic, sector
Frequency:	0.1 Hz

#### Test 6 —

Press the "clear" button to index the control counters.

- a. Depress the "span increase" lever for several seconds to move the counter control word to maximum.
- b. Depress the "span diminish" lever for several seconds to run the span counter down to its automatic limit of 3.175 deg.
- c. Depress the "center location" lever in the up and down directions; the upper and lower limits, as observed on the recorder, should move in unison (within  $\pm 3.2$  deg) maintaining a span of 6.4 deg.
- d. With the center of the scan excursion stopped, depression of the span control in the selected direction should provide monotone expansion about the original center angle.
- e. The span should be capable of expansion to  $\pm 30$  deg maximum, and the center be capable of excursion from 10 to 50 deg; the upper limit should be automatically restrained from exceeding 59 deg, and the lower limit shall be automatically restrained from falling below 3.2 deg. (These will inhibit symmetry of the scan limits about the center line under the appropriate circumstances.)

#### 4.4 RANGE CONTROLLER TESTS

The definitions and tests for range are identical to those for elevation, with the following exceptions.

- a. Range values correspond to ten times the counterparts in angle.
- b. Tests specifying 0.1 Hz scan frequency for  $\theta$  should be run at 1 Hz for range. Due to the higher speeds, changes in limit settings should be made every 5 seconds rather than once per cycle.
- c. The frequency tests of test 3 should be run at 0.1, 1, 2, 3, 4 and 5 Hz.

#### 4.5 SERVO PERFORMANCE TESTS

##### 4.5.1 Elevation Servo

##### 4.5.1.1 Static Accuracy — Manual Mode

Test 7 —

With the elevation system in the manual mode, the angle shall be slewed manually in 5 deg increments from 5 to 55 deg as indicated on the LED read-outs, and returned down through the same values. The angle indicated on the vernier dial should correspond to the LED reading to  $\pm 0.5\%$ .

##### 4.5.1.2 Dynamic Response — Automatic Mode

At the highest scan rate (0.5 Hz) and maximum excursion, ( $\approx 55$  deg) the phase shift between driving sawtooth command and mirror motion should not exceed 20 deg. The scan excursion should be within 5 deg of the command angle at both turnaround points. The period during which the scan velocity falls in absolute value to less than 75% of the command velocity shall not occupy more than 10% of the scan period.

These values shall be determined by stripchart recording of the command voltage and feedback pot voltage after the latter has been aligned and gains and offsets adjusted.

#### 4.5.2 Range Servo

##### 4.5.2.1 Static Accuracy

Since the actual location of the focus (point of maximum intensity of the illumination) is not observable within the control system, static accuracy tests should encompass at least one determination of the correspondence between the secondary mirror position and the location of the actual physical focus, using the following technique:

#### Test 8 -

- a. A Doppler wheel target shall be set up externally at range  $R_1$ ; the range servo shall be manually set to give an LED readout corresponding to  $R_1$ , and, with the loop closed, and elevation angle correctly aimed, the secondary mirror platform position is adjusted to give maximum voltage from a fixed I.F. bandwidth (non-scanning) spectrum analyzer signal power output terminal.
- b. The target is moved to range  $R_2$  and the spectrum analyzer output is again maximized by manually slewing the range to whatever new value accomplishes this. Both the LED readout and the optical encoder digital-to-analog converter voltage output corresponding to this maximum should be recorded. The latter value (after multiplication by the scale factor relating encoder angle to mirror translation) is to be taken as the mirror position - the positions should satisfy

$$(d_1 - d_2) = F^2 \left( \frac{1}{R_1} - \frac{1}{R_2} \right)$$

where  $d_1$  = mirror position  
 $F$  = system focal length  
 $R$  = target range

For this test,  $R_1 = 100$  meters,  $R_2 = 200$  meters.

## Test 9 – Static Accuracy

The output of the optical encoder digital-to-analog converter (which measures the secondary mirror position) shall be measured with a precision digital voltmeter while the range is slewed to successive positions 50 meters apart, from 50 to 550 meters, and back to 50 meters, stopping at the same values and maintaining monotone directional sense. The range values are those indicated by the LED range readouts. After conversion by the scale factor, the mirror position values should satisfy

$$d_i = \frac{F^2}{R_i}$$

(within an additive constant) to within 1% of the corresponding values based on the  $R_i$  observed on the LED. At each position of static range, the reconstructed range voltage shall also be measured, and after scale factor conversion this should be within 1% of the command range.

## 4.5.2.2 Dynamic Performance

## Test 10 –

The command range input voltage and the digital-to-analog (mirror position) voltage shall be simultaneously recorded on stripchart. The excursion shall be set to span 64 to 480 meters. A run shall be made at 0.1 Hz scan frequency for comparison purposes. When the scan frequency is increased to 5 Hz, the phase shift (between input sawtooth minima and mirror position maxima) shall not exceed 10 deg, and the excursion shall not depart by more than 5% from the low frequency values.

## 4.5.2.3 Line Scan Model and X, Y Output

## Test 11 -

An X, Y plotter shall be used to display the analog X, Y voltages before conversion. With the system in the line scan mode, successive values of  $R_h$  of 50, 150 and 199 meters shall be entered on the  $R_h$  thumbwheel, with the system scanning in elevation at 0.1 Hz between 3.2 deg and  $\theta_{UL}$ . After correction for scale factor, the X coordinate should remain within  $\pm 1\%$  of the value of  $R_h$ , and the maximum Y coordinate shall lie within  $\pm 1\%$  of the value corresponding to  $\theta_{UL}$ . For each  $R_h$ , the value of  $\theta_{UL}$  should be augmented by 10 deg from 10 to 50 deg in this test.

## Test 12 -

Using the same X, Y plotter as in test 11, the elevation scan should be set to scan at 0.1 Hz with a span of 3.2 to 59 deg, and values of range corresponding to 50-meter increments from 100 to 450 meters should be recorded. The X-Y traces should lie within circular arcs corresponding to  $\Delta R = \pm 1\% R_i$  for each  $R_i$ .

Section 5  
REPLACEABLE PARTS

The following lists of replaceable parts are included to assist in maintenance of the scanner system. Standard, readily available parts (such as resistors and capacitors) are not shown. All integrated circuits, modular components, special parts and items with long-lead times are listed. Particular manufacturers are shown for information only, or in some instances to indicate sole-source.

Integrated circuits marked by an asterisk are those that have indicated somewhat higher than normal failure rates.

## 5.1 INTEGRATED CIRCUITS (All ICs in dual-inline package)

Part Number	Type	No. per System	Notes
7400	Quad 2-input NAND gate	7	
7402	Quad 2-input NOR gate	2	
7404	Hex inverter	26	
7408	Quad 2-input AND gate	8	
7410	Triple 3-input NAND gate	1	
7432	Quad 2-input OR gate	12	
7437	Quad 2-input NAND buffer	7	
7447	BCD to seven-segment decoder/driver	6	
7473	Dual J-K flip-flop	4	
7474	Dual type D flip-flop	2	
7483	4-bit binary full adder	24	
7490	Decode counter	3	
7493	4-bit binary counter	1	
*7497	6-bit binary synchronous rate multiplier	6	Texas Instruments
74121	One-shot multivibrator	2	
*74167	Synchronous decode decimal rate multiplier	3	Texas Instruments
74185A	Binary-to-BCD converter	12	
74193	4-bit binary up/down counter	14	
75451A	Dual peripheral driver	1	
*9322	Quad 2-input multiplexer	36	Fairchild
*9324	5-bit comparator	28	Fairchild
725	Instrumentation operational amplifier	8	Fairchild
741	General purpose operational amplifier	4	



INTEGRATED CIRCUIT USAGE BY BOARD

Part No.	Used On	CE 1	CR 1	CE 2	CR 2	CE 3	CR 3	CE 4	CR 4	CE 5	CR 5	CE 6	CR 6	CE 7	CR 7	CE 8	CR 8	CE 9	CR 9	CE 10	CR 10	E 1	R 3	R 7	Front Panel	Inter-face	Total
7400				1	1	4	1																				7
7402				1	1																						2
7404								2	2	4	4	4	4	1	1	1	1							2			26
7408		3	3	1	1																						8
7410						1																					1
7432				3	3									2	2	1	1										12
7437						1		3	3																		7
7447																									6		6
7473				1	1	2																			6		4
7474						2																					2
7483										3	3	3	3	2	2	2	2								4		24
7490						3																					3
7493						1																					1
7497										3	3																6
74121				1	1																						2
74167																		1	2								3
74185A								6	6																		12
74193		3	3											2	2	2	2										14
75451A																									1		1
9322							3					3	3	2	2	2	2	3	4	6	6				1		36
9324		4	4									2	2	3	3	3	3			2	2						28
μ A725																						3					8
μ A741																						1		5		2	4

## 5.2 MODULAR COMPONENTS

Part Number	Type	No. per System	Notes
W118 DIP-5	Dual-inline-packaged read relay, SPDT, internal diode	8	Magnecraft
MAN 7	Seven-segment LED readout	6	Monsanto
425J	Precision analog multiplier	2	Analog Devices
433J	Multifunction module	3	Analog Devices
DAC40-128-BIN-PC	12-bit digital-to-analog converter	3	Burr-Brown
ADC40-10-BIN-PC	10-bit analog-to-digital converter	2	Burr-Brown
MA-1	DC servo amplifier	1	Inland Controls
UNI-30G OV	Power supply, 30 V at 12 A	1	Power/Mate
MR-1050-8	Power supply, 5 V at 1.5 A	1	Technetics
MR-3050-8	Power supply, $\pm 15$ V at 100 mA, +5 V at 1 A	1	Technetics
5W6	Power supply, 6 V at 800 mA	2	Elcom Industries
5W15	Power supply, 15 V at 300 mA	2	Elcom Industries
OLV 60-5	Power supply, 5 V at 12 A	1	Elevon Power Systems
SNB35-13 L1A	Optical shaft encoder	1	Encoder Div., Litton Industries
NOVA 34-3	3-digit display module	2	Precision Dynamics Corp.
AM 100A	DC servo amplifier	1	Aeroflex Labs., Inc.

## 5.3 MISCELLANEOUS COMPONENTS

Part Number	Type	No. per System	Notes
TQ25-9H	DC torque motor in housing	1	Aeroflex Labs., Inc.
V52Y-17	DC torque motor	1	Aeroflex Labs., Inc.
	Pot	1	Computer Instruments Corp.
2N3055	NPN power transistor	4	
A403	Heat sink	2	AAVID
1A228M	Thumbwheel switch	1	EECO
2A228M	Thumbwheel switch	1	EECO
29L10 Rev. A	Thumbwheel switch	1	Digitran
29L11 Rev. A	Thumbwheel switch	1	Digitran
B292-0108 Rev. A	Thumbwheel switch	1	Digitran
B292-0109 Rev. A	Thumbwheel switch	1	Digitran
B293-0108 Rev. A	Thumbwheel switch	1	Digitran
B293-0109 Rev. A	Thumbwheel switch	1	Digitran
B293-0110 Rev. A	Thumbwheel switch	1	Digitran
DX-4-B	Magnetic brake	1	PIC
25312	3-position switch, locking type, DPDT contacts	2	Switchcraft
25312	3-position switch, non-locking type, DPDT contacts	2	Switchcraft
MSH 203N3	Lever switch, DPDT contacts	8	Alco
MSP 205R	Pushbutton switch, momentary, with C12 button and G12A guard	6	Alco
FH227	Lever switch, mom., DPDT	4	JBT
BFK5 Red	5 V panel lamp	5	Alco
BFK5 Green	5 V panel lamp	3	Alco
MK15	Power transistor mounting kit	4	Motorola
342005	Fuseholder	7	Littlefuse
115C2T	Time-delay relay, 2 sec., 115 Vac heater, N. C. contacts	1	Amperite

Part Number	Type	No. per System	Notes
KRP11AG	Relay, 115 Vac coil, DPDT contacts	2	Potter and Brumfield
B1M-4E Red	Panel lamp, 115 Vac	1	Alco
B1M-4E Amber	Panel lamp, 115 Vac	1	Alco
972	Toggle switch DPST	1	Smith
34-000	Pushbutton switch, N. O. contacts	1	Switchcraft
102	Pushbutton switch, N. C. contacts	1	Switchcraft
KHU17011	Relay, 24 Vdc coil, 4 PDT contacts	3	Potter and Brumfield
50-44A-30	44-contact card edge connector	27	Cinch
50-15A-20	15-contact card edge connector	2	Cinch
57-30140	14-contact plug	6	Amphenol
57-40140	14-contact receptacle	6	Amphenol
57-30240	24-contact plug	7	Amphenol
57-40240	24-contact receptacle	7	Amphenol
57-30360	36-contact plug	1	Amphenol
57-40360	36-contact receptacle	1	Amphenol
57-30500	50-contact plug	4	Amphenol
57-40500	50-contact receptacle	4	Amphenol
DB-25S	25-contact receptacle	1	I. T. T. Cannon
W4-20	4-pin connector assembly	1	Continental Connector Corp.
126-217	5-pin plug with hood	2	Amphenol
126-218	5-pin socket with locking clip	2	Amphenol
RN60B4020F	Resistor, 402 ohms, 1%, 1/8 watt	1	
RN60B6810F	Resistor, 680 ohms, 1%, 1/8 watt	1	

Part Number	Type	No. per System	Notes
RN60B8060F	Resistor, 806 ohms, 1%, 1/8 watt	2	
RN60B1001F	Resistor, 1K ohms, 1%, 1/8 watt	1	
RN60B1401F	Resistor, 1.4K ohms, 1%, 1/8 watt	1	
RN60B1541F	Resistor, 1.54K ohms, 1%, 1/8 watt	2	
RN60B4021F	Resistor, 4.02K ohms, 1%, 1/8 watt	2	
RN60B5111F	Resistor, 5.11K ohms, 1%, 1/8 watt	1	
RN60B8251F	Resistor, 8.25K ohms, 1%, 1/8 watt	1	
RN60B1272F	Resistor, 12.7K ohms, 1%, 1/8 watt	1	
2N871	Transistor, NPN silicon	1	
2N3499	Transistor, NPN silicon	1	
1N2069	Diode rectifier	3	
	Molex connector, 24 pin		
	Molex connector, 15 pin		