

**NASA TECHNICAL NOTE**



**NASA TN D-7784**

**NASA TN D-7784**

**APOLLO EXPERIENCE REPORT -  
GUIDANCE AND CONTROL SYSTEMS:  
ORBITAL-RATE-DRIVE ELECTRONICS  
FOR THE APOLLO COMMAND MODULE  
AND LUNAR MODULE**

*by Roy B. Parker and Paul E. Sollock*

*Lyndon B. Johnson Space Center  
Houston, Texas 77058*



**NATIONAL AERONAUTICS AND SPACE ADMINISTRATION • WASHINGTON, D. C. • SEPTEMBER 1974**

1. Report No. NASA TND-7784	2. Government Accession No.	3. Recipient's Catalog No.	
4. Title and Subtitle APOLLO EXPERIENCE REPORT GUIDANCE AND CONTROL SYSTEMS: ORBITAL-RATE-DRIVE ELECTRONICS FOR THE APOLLO COMMAND MODULE AND LUNAR MODULE		5. Report Date September 1974	6. Performing Organization Code
		8. Performing Organization Report No. JSC S-409	10. Work Unit No. 914-50-17-08-72
7. Author(s) Roy B. Parker and Paul E. Sollock		11. Contract or Grant No.	13. Type of Report and Period Covered Technical Note
9. Performing Organization Name and Address Lyndon B. Johnson Space Center Houston, Texas 77058		14. Sponsoring Agency Code	
		12. Sponsoring Agency Name and Address National Aeronautics and Space Administration Washington, D.C. 20546	
15. Supplementary Notes The JSC Director waived the use of the International System of Units (SI) for this Technical Note because, in his judgment, the use of SI units would impair the usefulness of the report or result in excessive cost.			
16. Abstract A brief record of the development and use of the orbital-rate-drive assembly in the Apollo Program is presented. This device was procured as Government-furnished equipment and was used on both the lunar module and the command module. Reviews of design, development, procurement, and flight experience are included.			
17. Key Words (Suggested by Author(s)) · Attitude Indicators · Inertial Reference · Vertical Space Orientation · Attitude Control · Orbital Rates                      · Logic Circuits		18. Distribution Statement STAR Subject Category: 31.	
19. Security Classif. (of this report) None	20. Security Classif. (of this page) None	21. No. of Pages 30	22. Price \$3.25

## APOLLO EXPERIENCE REPORT

### EDITORIAL COMMITTEE

The material submitted for the Apollo Experience Reports (a series of NASA Technical Notes) was reviewed and approved by a NASA Editorial Review Board at the Lyndon B. Johnson Space Center consisting of the following members: Scott H. Simpkinson (Chairman), Richard R. Baldwin, James R. Bates, William M. Bland, Jr., Aleck C. Bond, Robert P. Burt, Chris C. Critzos, John M. Eggleston, E. M. Fields, Donald T. Gregory, Edward B. Hamblett, Jr., Kenneth F. Hecht, David N. Holman (Editor/Secretary), and Carl R. Huss. The prime reviewer for this report was Kenneth F. Hecht.

# CONTENTS

Section	Page
SUMMARY . . . . .	1
INTRODUCTION . . . . .	1
CONCEPT DEVELOPMENT . . . . .	2
DESIGN DEVELOPMENT . . . . .	4
SUBSYSTEM DESIGN . . . . .	4
BASIC SUBSYSTEM DESIGN EQUATIONS . . . . .	6
Fixed-Interval Counter and Gate Circuitry . . . . .	9
Orbital-Rate Fine-Adjust Circuitry . . . . .	9
DESIGN IMPLEMENTATION . . . . .	10
Interface Requirements . . . . .	10
Test Program . . . . .	11
CONCLUDING REMARKS . . . . .	12
APPENDIX . . . . .	13

## TABLES

Table	Page
I DATA PLOTTED TO OBTAIN LINEAR APPROXIMATION AND APPROXIMATION ERROR	
(a) Equation for Earth orbit . . . . .	15
(b) Equation for lunar orbit . . . . .	15
II APPROXIMATION ERROR $\epsilon$ FOR EARTH ORBIT . . . . .	17
III APPROXIMATION ERROR $\epsilon$ FOR LUNAR ORBIT . . . . .	18
IV APPROXIMATION ERROR $\epsilon$ FOR LUNAR ORBIT, BASED ON EQUATION (27) . . . . .	20
V BEST APPROXIMATION ERROR $\epsilon$ FOR LUNAR ORBIT . . . . .	20
VI ACCURACY OF THE ORDEAL AND ORDEAL PANEL	
(a) Earth orbit . . . . .	24
(b) Lunar orbit . . . . .	24
VII ACCURACY OF THE ORBITAL PERIOD . . . . .	24
VIII COMPARISON OF ALL ORDEAL ERRORS . . . . .	25

## FIGURES

Figure	Page
1 Displacement of the local-vertical reference frame with respect to the inertial reference frame (for an unperturbed spacecraft in a circular orbit) . . . . .	3
2 Schematic diagram of the ORDEAL . . . . .	5
3 Counter and gate, slew-rate, and orbital-rate fine-adjust circuitry	
(a) Counter and gate circuitry and slew-rate circuitry . . . . .	7
(b) Orbital-rate fine-adjust circuitry . . . . .	8
4 Comparison of $\frac{\tau_{STM, E}}{\alpha}$ and altitude . . . . .	16
5 Comparison of $\frac{\tau_{STM, L}}{\alpha}$ and altitude . . . . .	16

APOLLO EXPERIENCE REPORT  
GUIDANCE AND CONTROL SYSTEMS:  
ORBITAL-RATE-DRIVE ELECTRONICS FOR THE  
APOLLO COMMAND MODULE AND LUNAR MODULE

By Roy B. Parker and Paul E. Sollock  
Lyndon B. Johnson Space Center

SUMMARY

This document reviews the establishment of the requirement for the orbital-rate-drive, Earth and lunar, assembly for both the command module and the lunar module and includes aspects of spacecraft integration, design, and development. The orbital-rate-drive assembly is a device that generates a local-vertical output for display on the lunar module and command module flight director attitude indicators. The primary guidance, navigation, and control systems of both spacecraft are referenced to inertial space. Thus, when the spacecraft are in lunar or Earth orbit, the indicators are not referenced to local vertical; the orbital-rate-drive assembly provides this reference. The assembly drives, or precesses, the attitude indicator at the orbital rate of the vehicle such that the attitude indicator will, at the discretion of the astronaut, present a local-vertical reference.

The orbital-rate-drive assembly was flown on every manned Apollo vehicle, and there were no flight failures or anomalies of this equipment. A detailed review of the mathematical, mechanical, and electrical specifications that were used in designing and manufacturing the assembly is included in this report. A brief summary of the development program includes a test program history. The decision to supply the orbital-rate-drive assembly as Government-furnished equipment resulted in a significant cost saving for the Government.

INTRODUCTION

Originally, the command module (CM) and the lunar module (LM) contractors were to supply the equipment that would provide a local-vertical indication to the flight crew. The NASA determined that this equipment would have similar functions and interfaces in both vehicles.

After receiving cost proposals from both contractors for providing this equipment, NASA investigated the possibility of supplying the equipment as Government-furnished equipment. The engineering design was developed by the NASA Lyndon B. Johnson Space Center (JSC) (formerly the Manned Spacecraft Center (MSC)), and a specification was issued to prospective suppliers for bids. A contract was awarded, and the equipment was produced in accordance with NASA performance and parts specifications and interface control documents. Details of the equipment development, procurement, and flight performance are discussed.

## CONCEPT DEVELOPMENT

As in any engineering task, many solutions, each with varying degrees of merit, were considered in the concept development. The primary considerations included accuracy, ease of implementation, and applicability to primary and backup systems. If a candidate solution satisfied these broad requirements, then specific items such as power, weight, and volume were considered.

Because of dissimilarities between the primary and backup systems in the LM and the CM, it was soon apparent that either a local-vertical modification for each primary and secondary system should be devised or some type of local-vertical attitude bias that worked indiscriminately on the output of either system should be inserted. The attitude display of chief concern (used for all guidance modes with primary and backup systems) was the flight director attitude indicator (FDAI). A biased attitude signal applied to the FDAI of either spacecraft would provide only a local-vertical display, rather than a true platform reference. Preliminary discussions with crewmembers indicated that a local-vertical display was sufficient because the vehicle was manually pointed toward the target and the FDAI was monitored to provide the angle between the line of sight and the local vertical. In a typical rendezvous, it was reasoned, a pilot could manually point his vehicle toward the target while monitoring the FDAI for the angle between the line of sight and the local vertical. After thoroughly examining the modifications required for each system to provide inherent local-vertical modes, the investigators decided on an independent device that would insert a bias signal at the FDAI input.

Most rendezvous attitude maneuvers are rotations about the spacecraft pitch axis. The line-of-sight/local-horizontal measurement is a pitch angle represented by movement of the FDAI pitch gimbal. Thus, the input signal bias required for an FDAI local-vertical display would not affect the FDAI yaw and roll gimbals. For such a display to be meaningful, the spacecraft must be aligned to the orbital plane so that only the spacecraft pitch axis will be affected by the orbital rate. The spacecraft roll and yaw axes must therefore remain in the orbital plane, with the pitch axis parallel to the orbital-rate axis.

In figure 1, an unperturbed spacecraft is shown at successive times  $T_1$  and  $T_2$  of a circular orbital period. At  $T_1$ , the inertial reference frame and the local-vertical reference frame coincide. At  $T_2$ , the local-vertical reference frame is displaced  $B$  degrees from the inertial reference frame. The sum of the inertial pitch angle  $A$

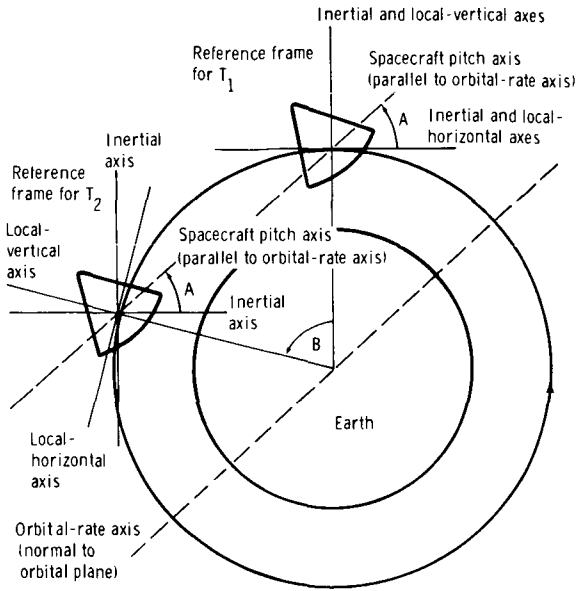

Figure 1. - Displacement of the local-vertical reference frame with respect to the inertial reference frame (for an unperturbed spacecraft in a circular orbit).

and the  $T_2$  displacement angle  $B$  equals the total angular displacement from  $0^\circ$  pitch as measured in the local-vertical reference frame at time  $T_2$ . If a signal bias equivalent to  $B$  and a signal equivalent to  $A$  are summed in a resolver, the resulting output signal, applied to a spacecraft FDAI, will displace the pitch gimbal by angle  $A$  plus angle  $B$ ; if changes in angle  $B$  are continually added to the resolver input, the pitch measurement displayed on the FDAI will be referenced to local vertical at all times.

Input signals to the FDAI in each spacecraft are 400- or 800-hertz modulated analog voltages representing the sines and cosines of the respective angles. By inserting a resolver in the attitude signal lines for each FDAI, angle  $A$  and angle  $B$  can be summed according to the trigonometric identities

$$\left. \begin{aligned} \sin(A + B) &= \sin A \cos B + \cos A \sin B \\ \cos(A + B) &= \cos A \cos B - \sin A \sin B \end{aligned} \right\} (1)$$

However, to determine angle  $B$  at any given time, it is necessary to establish the rotational rate  $\dot{B}$  of the vertical reference frame with respect to the inertial reference frame. The rate of change of  $B$  is a function of orbital altitude. Keplerian equations describing orbital period as a function of altitude permit linear approximation of circular orbital cases. Thus, driving the resolver shaft at a rate  $\dot{B}$ , as determined by the linearized equations, constantly updates the local-vertical reference frame. Power, weight, and accuracy analyses indicate that the best orbital-rate-drive design consists of a stepper motor capable of mechanically driving the resolver shaft at a rate determined by a discrete pulse train. Each discrete pulse represents an increment of change in the position of the local-vertical reference frame with respect to the inertial reference frame. Thus, the magnitude of the bias applied to an FDAI input signal is determined by the time interval between stepper-motor output pulses. Such an orbital-rate-drive, Earth and lunar assembly (ORDEAL) is accurate only in cases of circular or nearly circular orbits.



## DESIGN DEVELOPMENT

A breadboard unit was constructed by NASA for a thorough laboratory evaluation of the design. The computational electronics were mechanized by the use of a voltage-to-frequency converter that provided an output pulse rate proportional to an input voltage. The input voltage was controlled by a precision potentiometer calibrated in terms of orbital altitude. The basic breadboard unit was built and then optimized during the evaluation program. Temperature, off-nominal supply voltage, and noise-sensitivity tests were performed, and modifications were incorporated into the breadboard unit when needed to improve performance. The final breadboard unit was used as a basis for extrapolating power, weight, volume, and accuracy calculations to a flight-packaged version.

To verify the entire concept, the breadboard unit was integrated with an existing hardware simulation that included actual Block I stabilization and control subsystem (SCS) hardware. The interface and all operational parameters were verified.

The use of the ORDEAL, as designed, was limited to circular orbits with the pitch axis orthogonal to the orbital plane. However, the ORDEAL was applicable to both the primary guidance, navigation, and control system (PGNCS) and the backup systems and resulted in minimal impact to existing systems.

## SUBSYSTEM DESIGN

Design of the ORDEAL enables the subsystem to be switched directly into the FDAI total attitude cables for performing a coordinate transformation of spacecraft pitch from an inertial to a local-vertical reference frame. When the ORDEAL panel switches are in the orbital-rate position, sines and cosines of the pitch angle are applied as inputs to a pair of resolvers in the ORDEAL electromechanical module (containing the stepper motor, the gear-train assembly, and the two resolvers). The shafts of these resolvers are driven (by the stepper motor and the gear-train assembly) to an angle  $B$ , and the resolver outputs are therefore rotated by angle  $B$ . Whenever these ORDEAL panel switches are in the normal (inertial) position, the ORDEAL is bypassed, and the FDAI units display pitch to the inertial frame of reference.

The astronaut must set the initial value of  $B$  with the slew switch on the panel, and this value must change at a rate equal to the desired orbital rate of the spacecraft. The orbital rate  $\dot{B}$  is set by the altitude control. A schematic diagram of the ORDEAL is shown in figure 2.

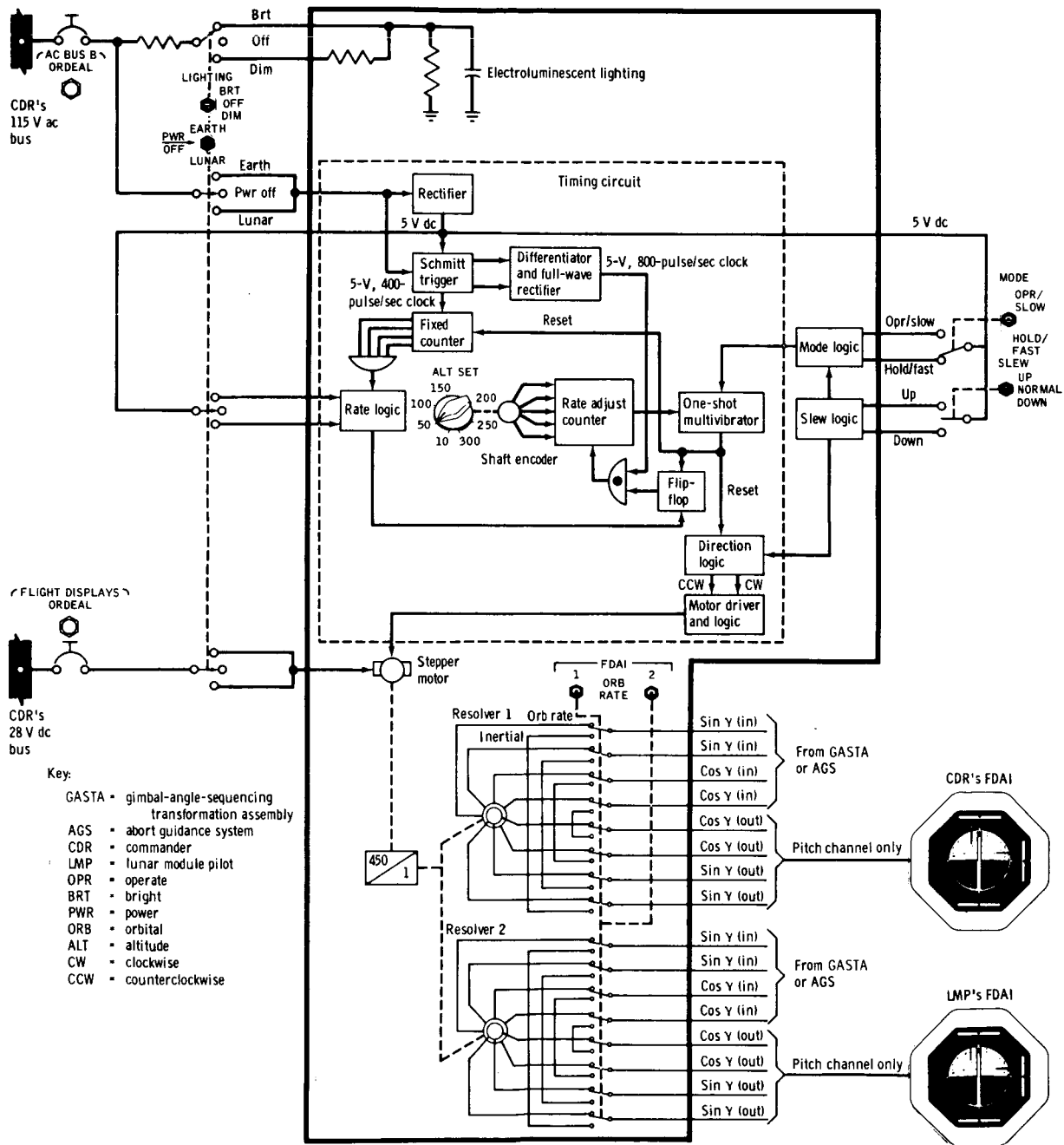

Figure 2. - Schematic diagram of the ORDEAL.

## BASIC SUBSYSTEM DESIGN EQUATIONS

As stated previously, the rate of change in the shaft angle  $B$  is set to the desired orbital rate  $\dot{B}$  by the altitude control. This rate of change of  $B$  is established by using the existing 400-hertz spacecraft frequency as a basic timing reference and by using a shaft-angle encoder, a digital logic, and a stepper-motor drive.

The expressions for the time period between stepper-motor pulses  $\tau_{STM}$  as a function of altitude  $h$  and degrees of resolver-shaft rotation per pulse  $\alpha$  are derived. (The derivations of these expressions are given in the appendix.) Note that the exact expressions for orbital period are used, and a nearly linear approximation function is obtained. These expressions are

$$\tau_{STM, E} = (14.0912 + 0.006327h)\alpha \quad (2)$$

and

$$\tau_{STM, L} = (17.9236 + 0.03171h)\alpha \quad (3)$$

for Earth orbit and lunar orbit, respectively. Based on the requirements for accuracy (2 deg/hr), resolution (2.5 nautical miles), and altitude range (10 to 310 nautical miles) and using  $285^\circ$  as the total travel of the altitude-control shaft, the allowable gear ratio is 450:1. Use of this gear ratio gives  $\alpha = 90^\circ/450 = 0.20$  deg/pulse. Therefore,  $\tau_{STM}$  as a function of  $h$  is

$$\tau_{STM, E} = 2.8182 + 0.001265h \text{ sec} \quad (4)$$

and

$$\tau_{STM, L} = 3.5847 + 0.006342h \text{ sec} \quad (5)$$

for Earth orbit and lunar orbit, respectively. The desired time between stepper-motor pulses is obtained by a fixed-interval counter giving the first term of the right side of the equations and by an adjustable counter in sequence with the fixed-interval counter. The adjustable counter provides the altitude variation.

Functional schematics of the circuits are shown in figure 3. The slew-rate circuitry is discussed in the appendix; the fixed-interval counter and gate circuitry and the orbital-rate fine-adjust circuitry are discussed as follows.

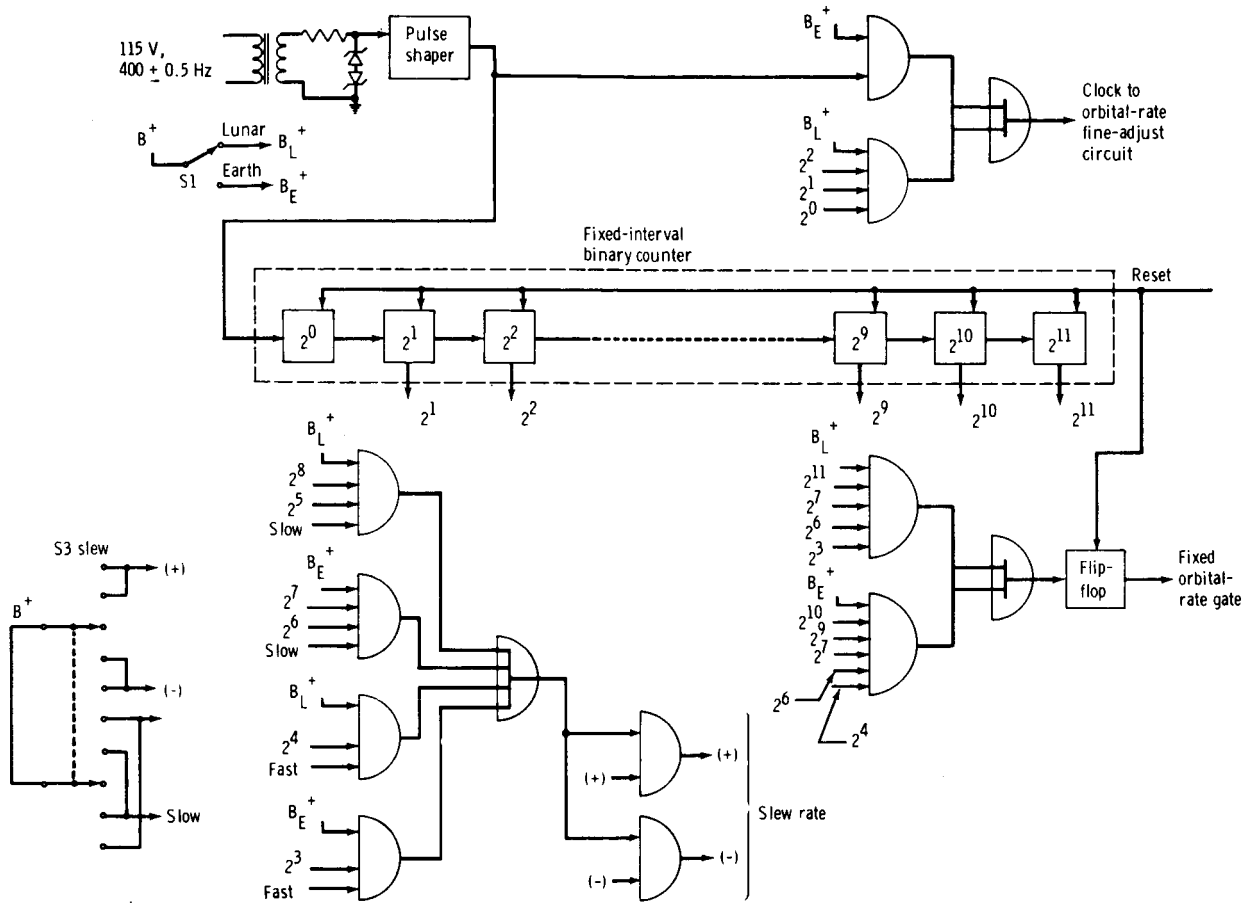

(a) Counter and gate circuitry and slew-rate circuitry.

Figure 3. - Counter and gate, slew-rate, and orbital-rate fine-adjust circuitry.

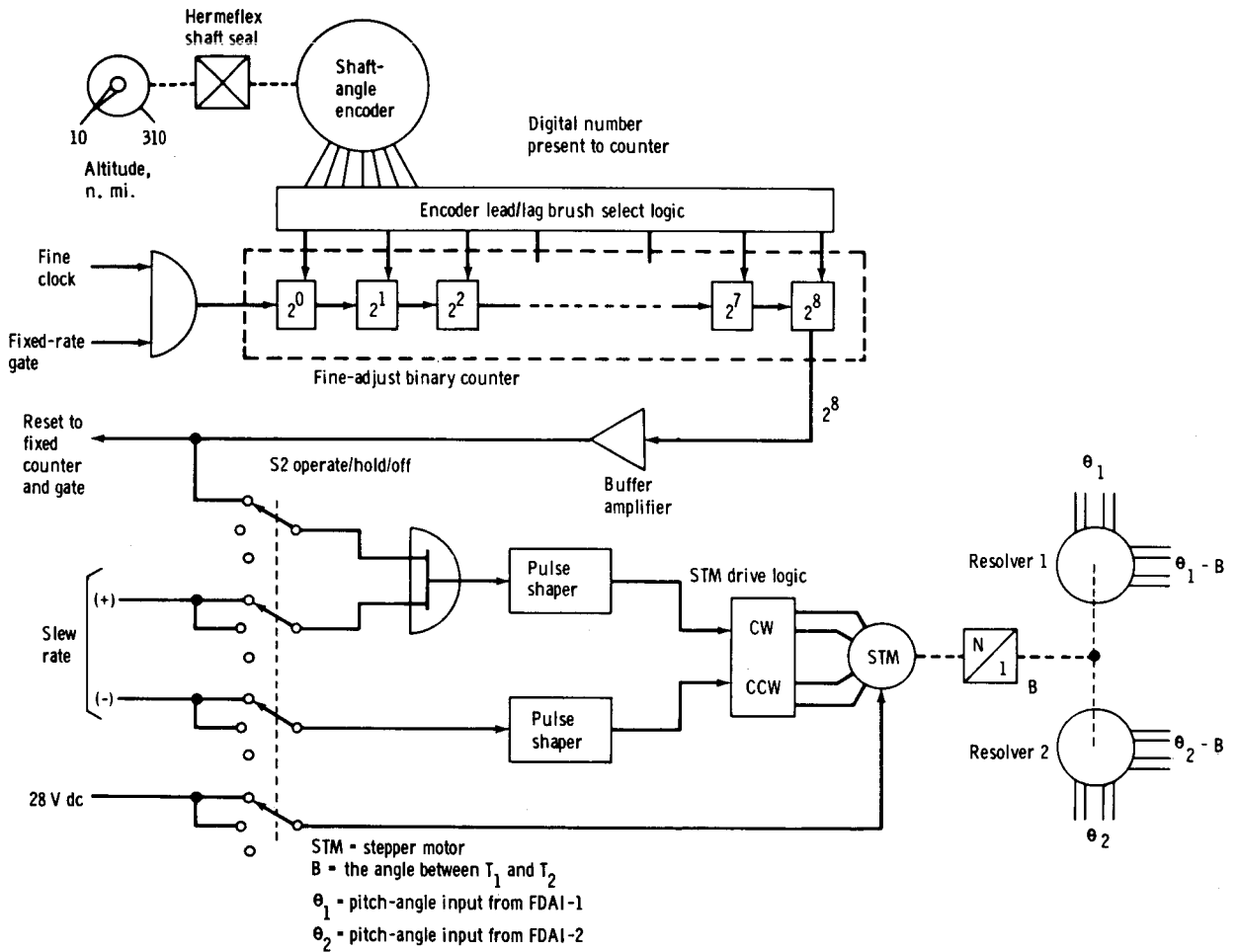

(b) Orbital-rate fine-adjust circuitry.

Figure 3. - Concluded.

## Fixed-Interval Counter and Gate Circuitry

The fixed-interval counter and gate circuitry consists of the fixed-interval 11-bit binary counter, a pair of logic AND gates, an OR gate, and a flip-flop. The spacecraft 115-volt, 400-hertz power is level-adjusted, squared by a Schmitt-trigger circuit, and applied to a fixed-interval counter. In addition, both collectors of the Schmitt trigger are connected to a differentiating circuit. The positive portion of both square waves is amplified by the pulse amplifier to form the 800-hertz clock frequency.

The number of counts desired to obtain the fixed time delay is 1131 counts for Earth orbit (derived in the appendix). Using signals from the fixed-interval gate counter, the AND gate circuitry generates 1131 counts.

$$1131 = 2^{10} + 2^6 + 2^5 + 2^3 + 2^1 + 2^0 \quad (6)$$

For lunar orbit, the number of counts desired to obtain the fixed time delay is 1454 counts, and

$$1454 = 2^{10} + 2^8 + 2^7 + 2^5 + 2^3 + 2^2 + 2^1 \quad (7)$$

The AND gates produce an output pulse when the desired count is reached. One AND gate is used for Earth orbit and the other for lunar orbit; the desired gate is enabled by the Earth or lunar orbit power (EARTH/LUNAR PWR) switch on the ORDEAL switch panel. The output pulse sets the flip-flop to set the OR gate. The OR gate remains set until a pulse is delivered to the stepper motor, at which time the AND gate and the fixed-interval counter are reset.

## Orbital-Rate Fine-Adjust Circuitry

When the fixed amount of time has elapsed, the orbital-rate fine-adjust circuitry is enabled. This time-delay circuitry adds a small time increment (proportional to altitude) to the fixed time period. The fine time increment is generated by the shaft-angle encoder and the 7-bit counter. The 7-bit counter will produce an output pulse when a count of 128 is reached. The time of this count can be adjusted by presetting the counter to any one of the previous 127 counts. The shaft position of the encoder determines the preset count.

The clock frequency of the 7-bit counter must be made equal to the scaling factor of the second term on the right side of the  $\tau_{STM}$  equations (eqs. (4) and (5)). The required resolution of the altitude setting is 2.5 nautical miles. A 128-count encoder

can be used to divide the altitude range into 285/360 of the 128 increments (285° panel angle); that is, into 101 increments. Hence, the resolution is

$$\Delta h = \frac{\text{altitude range}}{101} = \frac{310 - 10}{101} = 2.96 \text{ n. mi./count} \quad (8)$$

For Earth orbit, each count of the encoder is equal to

$$\Delta\tau_{\text{STM,E}} = 0.001265(2.96) = 0.00374 \text{ sec} \quad (9)$$

The closest integral multiple of 0.00125 second is 0.00375 second, which is used as the time interval. For lunar orbit, each count of the encoder is equal to

$$\Delta\tau_{\text{STM,L}} = 0.006342(2.96) = 0.01877 \text{ sec} \quad (10)$$

The closest integral multiple of 0.00125 second is 0.01875 second, which is used as the time interval. Actually, these frequencies were chosen as the starting point of the design. (Refer to the appendix.)

## DESIGN IMPLEMENTATION

The design implementation section includes a discussion of interface requirements and of the test program.

### Interface Requirements

Mechanical requirements. - The CM and LM mechanical interface requirements differ. The CM ORDEAL unit is stowed during launch and landing and is mounted on a bracket during use. The CM unit has switch guards to prevent inadvertent activation of the ORDEAL during stowing and unstowing operations and during periods of astronaut movement in the cabin. The LM ORDEAL unit is permanently installed, and, because of limited vehicle accessibility space, no switch guards are provided. The CM and LM ORDEAL units are mechanically interchangeable with the attachment of appropriate mounting brackets and with the removal or installation of switch guards.

Electrical requirements. - In the CM, the reference attitude signal is generated by either the PGNCs or the SCS; the ORDEAL must operate with either or both of these systems. The CM ORDEAL, when selected for use, drives the FDAI. In the LM, the reference attitude signal is generated by either the PGNCs or the abort guidance

system; the LM ORDEAL must operate with either or both of these systems. Because the PGNCS/FDAI gimbal orientation is incompatible on the LM, the LM contractor supplied a gimbal-angle-sequencing transformation assembly that would effect the proper coordinate transformation. Although the FDAI units on the LM and the CM were manufactured by different contractors, the CM and LM ORDEAL units are electrically interchangeable.

## Test Program

Development testing. - The interface requirements of the various systems were considered by the LM and CM contractors to be incompatible with a single ORDEAL configuration. To ensure compatibility, NASA provided development models of the ORDEAL circuitry to the LM, CM, and PGNCS contractors for interface testing. After the systems were tested in all combinations of operation, the contractors agreed that a common design was acceptable, and appropriate interface control documents were generated and signed by all parties. No prototype hardware was built; production began as soon as development was completed.

Parts testing. - Minimal development testing was necessary on the ORDEAL parts, which either were high-reliability parts or had previously been used in qualification-tested military hardware. Electronic parts were subjected to screening and burn-in processes, and all parts were 100-percent inspected. All parts specifications and fabrication processes were reviewed and approved by NASA.

Qualification testing. - The qualification requirements were generated by integrating the requirements for the ORDEAL in the CM and LM environments. The worst-case environment was used when the LM and CM environments differed. A complete test program that included all Apollo environments was performed. No failures occurred during the qualification test program.

Flammability testing. - During the development program, the use of nonflammable materials was emphasized. The electroluminescent panel was covered with an aluminum overlay; all other exposed parts, with the exception of one control knob, were of nonflammable materials. During the flammability testing, it was determined that a portion of the knob was flammable; the material in this portion was changed to aluminum before delivery of the first ORDEAL unit.

Preinstallation acceptance testing. - Complete preinstallation acceptance testing was performed on all units at the ORDEAL manufacturer's facility. The units were then delivered to the LM and CM contractors' facilities, where they were installed without further testing.

Flight history. - The ORDEAL has been flown on 11 command modules and 9 lunar modules, with no anomalies.

Delivery history. - The original contract established a requirement for delivery of 26 ORDEAL units. Delivery was to begin 5 months after contract awarding and was to proceed at the rate of two units per month for 13 months. Although NASA realized that this schedule was unrealistic for delivery of the first few units, establishment of



the schedule did encourage the ORDEAL contractor to deliver equipment as early as practical. Equipment deliveries actually began 11 months after contract negotiation and were completed 14 months later. Orders for more equipment and additional NASA test requirements contributed to the delay in hardware delivery. Even though the equipment delivery began later than had been planned, the vehicle installation dates were adequately supported, and no problems were encountered.

## CONCLUDING REMARKS

The orbital-rate-drive assembly was designed, developed, qualified, and delivered within a period of 11 months. The configurations used on two different types of vehicles manufactured by different contractors were virtually the same.

The decision to procure the equipment as Government-furnished equipment resulted in a significant cost saving. The use of interface control documents for the control of mechanical, electrical, and functional interfaces was an important factor in minimizing costs. The judicious parts selection by the orbital-rate-drive assembly contractor, the review and approval by NASA, and the screening of all parts contributed to the excellent performance of this equipment. The selection of a well-qualified contractor to supply the orbital-rate-drive assembly and attentive NASA engineering and management resulted in equipment that met all cost, delivery, and performance requirements.

Lyndon B. Johnson Space Center  
National Aeronautics and Space Administration  
Houston, Texas, May 7, 1974  
914-50-17-08-72

## APPENDIX

### DERIVATION OF THE DESIGN EQUATIONS

#### DERIVATION OF THE LINEAR APPROXIMATION EQUATION

Design of the orbital-rate-drive, Earth and lunar (ORDEAL), assembly is based on Earth-orbital-rate and lunar-orbital-rate equations, as stated previously in the text. The orbital period equation is

$$T = K \left( 1 + \frac{h}{r} \right)^{\frac{3}{2}} \quad (11)$$

where  $T$  is the orbital period in hours,  $h$  is the orbital altitude in nautical miles,  $r$  is the planetary radius in nautical miles,  $K$  is the planetary constant defined by  $2\pi r^{3/2}/GM^{1/2}$ ,  $G$  is the universal gravitational constant, and  $M$  is the mass of the attracting planet. The orbital rate is

$$\dot{B} = \frac{360 \text{ (deg/rev)}}{T \text{ (hr/rev)} \times 3600 \text{ (sec/hr)}} = \frac{0.1}{T} \text{ deg/sec} \quad (12)$$

By substituting equation (11) into equation (12)

$$\dot{B} = \frac{0.1}{K \left( 1 + \frac{h}{r} \right)^{\frac{3}{2}}} \text{ deg/sec} \quad (13)$$

The expression for the time between stepper-motor pulses is

$$\tau_{STM} = \frac{\alpha}{\dot{B}} = 10\alpha K \left( 1 + \frac{h}{r} \right)^{\frac{3}{2}} \text{ sec} \quad (14)$$

where  $\alpha$  is resolver-shaft rotation in degrees per pulse at the output. For Earth orbit

$$\tau_{STM, E} = \alpha(14.1) \left(1 + \frac{h}{3420}\right)^{\frac{3}{2}} \text{ sec} \quad (15)$$

where  $K = 1.41$  and  $r = 3420$  nautical miles. For lunar orbit

$$\tau_{STM, L} = \alpha(18.1) \left(1 + \frac{h}{933}\right)^{\frac{3}{2}} \text{ sec} \quad (16)$$

where  $K = 1.81$  and  $r = 933$  nautical miles. In equations (15) and (16),  $h$  is orbital altitude and must vary from 10 to 310 nautical miles. Equations (15) and (16) are then plotted to obtain the linear approximation and to determine the approximation error  $\epsilon$ . The forms of the equations and the data plotted are presented in table I.

Plots of  $\tau_{STM}/\alpha$  as a function of  $h$  for Earth and lunar orbits are shown in figures 4 and 5, respectively. Note that these plots are straight lines (within the plot accuracy). By using the 85- and 235-nautical-mile points, the mathematical expression for the straight line is derived. The errors at other points based on this linear approximation are then checked.

For Earth orbit

$$\left. \begin{aligned} \frac{\tau_{STM, E}}{\alpha} \Big|_{h=85} &= 14.629 \\ \frac{\tau_{STM, E}}{\alpha} \Big|_{h=235} &= 15.578 \end{aligned} \right\} \quad (17)$$

TABLE I. - DATA PLOTTED TO OBTAIN LINEAR APPROXIMATION  
AND APPROXIMATION ERROR

(a) Equation for Earth orbit:  $\frac{\tau_{STM,E}}{\alpha} = 14.1 \left(1 + \frac{h}{3420}\right)^{\frac{3}{2}}$

h, n. mi.	$\left(1 + \frac{h}{3420}\right)^{\frac{3}{2}}$	$\frac{\tau_{STM,E}}{\alpha}$ , sec/deg
10	1.0044	14.162
85	1.0375	14.629
160	1.0710	15.101
235	1.1048	15.578
310	1.1393	16.064

(b) Equation for lunar orbit:  $\frac{\tau_{STM,L}}{\alpha} = 18.1 \left(1 + \frac{h}{933}\right)^{\frac{3}{2}}$

h, n. mi.	$\left(1 + \frac{h}{933}\right)^{\frac{3}{2}}$	$\frac{\tau_{STM,L}}{\alpha}$ , sec/deg
10	1.0162	18.2955
85	1.1399	20.6322
160	1.2676	22.9436
235	1.401	25.3580
310	1.538	27.8380

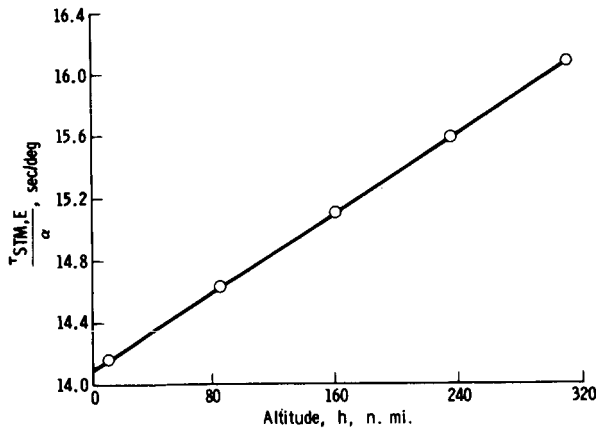

Figure 4. - Comparison of  $\frac{\tau_{STM,E}}{\alpha}$  and altitude.

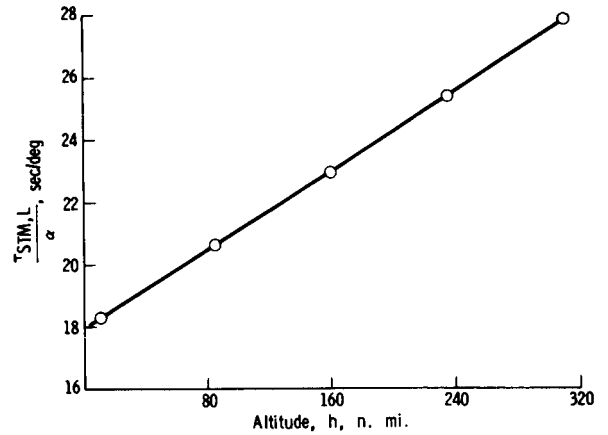

Figure 5. - Comparison of  $\frac{\tau_{STM,L}}{\alpha}$  and altitude.

Write these equations in the linear form  $y = a + bx$ , and determine  $a$  and  $b$  as follows.

$$\left. \begin{aligned} 14.629 &= a + b(85) \\ 15.578 &= a + b(235) \end{aligned} \right\} \quad (18)$$

$$\left. \begin{aligned} a &= 14.0912 \\ b &= 0.006327 \end{aligned} \right\} \quad (19)$$

The linear approximation to the design equation is therefore

$$\frac{\tau_{STM,E}}{\alpha} = 14.0912 + 0.006327h \quad (20)$$

where the approximation error  $\epsilon$  is shown in table II.

TABLE II. - APPROXIMATION ERROR  $\epsilon$  FOR EARTH ORBIT

h, n. mi.	Calculated $\frac{\tau_{STM,E}}{\alpha}$ , sec/deg	Theoretical $\frac{\tau_{STM,E}}{\alpha}$ , sec/deg	$\epsilon$ , sec/deg	$\epsilon$ , per- cent
10	14.155	14.162	-0.007	-0.05
85	14.629	14.629	0	0
160	15.104	15.101	.003	.02
235	15.578	15.578	0	0
310	16.053	16.064	-.011	-.07

For lunar orbit

$$\left. \begin{aligned} \frac{\tau_{STM,L}}{\alpha} \Big|_{h=85} &= 20.6322 \\ \frac{\tau_{STM,L}}{\alpha} \Big|_{h=235} &= 25.3580 \end{aligned} \right\} \quad (21)$$

Write these equations in the linear form  $y = a + bx$ , and determine  $a$  and  $b$  as follows.

$$\left. \begin{aligned} 20.6322 &= a + b(85) \\ 25.3580 &= a + b(235) \end{aligned} \right\} \quad (22)$$

$$\left. \begin{aligned} a &= 17.9531 \\ b &= 0.03151 \end{aligned} \right\} \quad (23)$$

The linear approximation to the design equation is therefore

$$\frac{\tau_{STM,L}}{\alpha} = 17.9531 + 0.03151h \quad (24)$$

where the approximation error  $\epsilon$  is shown in table III.

TABLE III. - APPROXIMATION ERROR  $\epsilon$  FOR LUNAR ORBIT

h, n. mi.	Calculated $\frac{\tau_{STM,L}}{\alpha}$ , sec/deg	Theoretical $\frac{\tau_{STM,L}}{\alpha}$ , sec/deg	$\epsilon$ , sec/deg	$\epsilon$ , per- cent
10	18.2682	18.2955	-0.0273	-0.15
85	20.6315	20.6322	-.0007	0
160	22.9947	22.9436	.0511	.223
235	25.3580	25.3580	0	0
310	27.7212	27.8380	-.117	-.41

The overall maximum allowable ORDEAL error according to NASA specification is 2 deg/hr. The orbital rate is

$$\frac{1}{\tau_{STM}} \text{ (pulses/sec)} \times \alpha \text{ (deg/pulse)} = \frac{\alpha}{\tau_{STM}} \text{ (deg/sec)} \quad (25)$$

The worst-case approximation error occurs in the lunar orbital case at an altitude of 310 nautical miles.

$$\left. \begin{aligned} \frac{\alpha}{\tau_{STM}} &= \frac{1}{27.8380} \cong 0.0359 \text{ deg/sec} = 0.0359 \times 3600 \text{ sec/hr} = 129 \text{ deg/hr} \\ \text{Percent } \epsilon \text{ allowed} &= \frac{2}{129} = 1.55 \text{ percent} \end{aligned} \right\} \quad (26)$$

Therefore, the 0.41-percent approximation error would be acceptable. However, the approximation error can be reduced by a more even distribution of error.

Choose 45 and 275 nautical miles as zero-error points in the lunar orbital case. Lunar orbital theoretical values at 45 and 275 nautical miles are as follows.

h	$\left(1 + \frac{h}{933}\right)^{\frac{3}{2}}$	$\frac{\tau_{STM,L}}{\alpha}$
45	1.0733	19.4267
275	1.4737	26.6740

The linear equation obtained by using these points in the equation  $y = a + bx$  is

$$\frac{\tau_{STM,L}}{\alpha} = 18.0088 + 0.03151h \quad (27)$$

Equation (24) provides a more even distribution of error than the distribution shown in table IV. Equation (27) has shifted the error, but the value is still not optimum. To further reduce the error, set it at 10 and 310 nautical miles equal to -0.3 percent. The approximation error for the design equation at altitudes of 10 and 310 nautical miles is therefore -0.0548 and -0.0836 sec/deg, respectively, with corresponding calculated values of 18.2407 and 27.7544 sec/deg. The linear equation obtained by using these points in the equation  $y = a + bx$  is

$$\frac{\tau_{STM,L}}{\alpha} = 17.9236 + 0.03171h \quad (28)$$

Equation (28) provides the best approximation of the ORDEAL design equation, as indicated in table V.

## DETERMINATION OF FREQUENCY AND RELATED PARAMETERS

Now that the linear orbital equations have been derived, the frequency to the encoder, the stepper-motor-to-resolver gear ratio, and the encoder counts for full range can be determined. The ORDEAL will use the 400-hertz spacecraft power as a clock-frequency source. The accuracy of the 400-hertz pulse is  $\pm 0.5$  hertz, which is a maximum error of  $\pm 0.125$  percent. This 400-hertz frequency will be counted down to produce the desired fixed time interval and the proper time-encoder count (pulse rate to encoder).



TABLE IV. - APPROXIMATION ERROR  $\epsilon$  FOR LUNAR ORBIT,  
 BASED ON EQUATION (27)

h, n. mi.	Calculated $\frac{\tau_{STM,L}}{\alpha}$ , sec/deg	Theoretical $\frac{\tau_{STM,L}}{\alpha}$ , sec/deg	$\epsilon$ , sec/deg	$\epsilon$ , per- cent
10	18.3239	18.2955	0.028	0.164
85	20.6872	20.6322	.055	.267
160	23.0504	22.9436	.107	.467
235	25.4137	25.3580	.056	.221
310	27.7769	27.8380	-.061	-.219

TABLE V. - BEST APPROXIMATION ERROR  $\epsilon$  FOR LUNAR ORBIT

h, n. mi.	Calculated $\frac{\tau_{STM,L}}{\alpha}$ , sec/deg	Theoretical $\frac{\tau_{STM,L}}{\alpha}$ , sec/deg	$\epsilon$ , sec/deg	$\epsilon$ , per- cent
10	18.2407	18.2955	-0.0548	-0.29
85	20.6190	20.6322	-.0132	-.05
160	22.9972	22.9436	.0536	.24
235	25.3755	25.3580	.0175	.07
310	27.7537	27.8380	-.0843	-.30

The encoder clock frequency, the encoder resolution, and the stepper-motor-to-resolver gear ratio are all interrelated. The relationship is seen by considering the following from equations (20) and (28).

$$\Delta\tau_{STM,E} = 0.006327\alpha(\Delta h) \quad (29)$$

and

$$\Delta\tau_{STM,L} = 0.03171\alpha(\Delta h) \quad (30)$$

where  $\Delta\tau_{STM}$  is the increment of seconds per pulse for the  $\Delta h$ ,  $\Delta h$  is the altitude increment (defines the encoder resolution) in nautical miles,  $\alpha$  is the resolver-shaft rotation (defines the gear ratio) in degrees per pulse, and  $\Delta h$  (minimum) is the encoder resolution. In addition,  $\Delta\tau_{STM}$  defines the encoder clock frequency (since  $f = 1/\Delta\tau$ ), and the desired relationship is defined by equations (29) and (30).

The value of  $\alpha$  for the 400-hertz pulse is 0.20 deg/pulse; therefore

$$\Delta\tau_{STM,E} = 0.006327(0.20)\Delta h = 0.0012654 \Delta h \quad (31)$$

and

$$\Delta\tau_{STM,L} = 0.03171(0.20)\Delta h = 0.006342 \Delta h \quad (32)$$

If a clock frequency of 800 hertz is generated, three times the smallest time interval for encoder counting is 0.00375. The use of this value in computing  $\Delta h$  for Earth and lunar orbit gives

$$\Delta h_E = \frac{0.00375}{0.0012654} = 2.9635 \text{ n. mi./count} \quad (33)$$

and

$$\Delta h_L = \frac{0.01875}{0.006342} = 2.9564 \text{ n. mi./count} \quad (34)$$

With a 2.96-n.-mi./count resolution and a 300-nautical-mile altitude range, the number of counts is 101. For a 7-bit counter, an output pulse is generated every 128 counts. The ratio of the number of pulses to the number of counts is 0.790. When related to the travel of the altitude-control shaft, this ratio becomes  $0.790(360^\circ) = 285^\circ$ .

To select the fixed and fine time intervals, refer to equations (20) and (28). As stated previously,  $\alpha = 0.20$  deg/pulse. Therefore

$$\tau_{STM,E} = 2.8182 + 0.001265h \text{ sec} \quad (35)$$

and

$$\tau_{STM,L} = 3.5847 + 0.006342h \text{ sec} \quad (36)$$

For  $h = 10$  in equations (35) and (36),  $\tau_{STM,E} = 2.83089$  seconds and  $\tau_{STM,L} = 3.65364$  seconds. Use of the time increment of 0.00250 second in obtaining the number of counts for the coarse time counter  $C_C$  gives

$$C_{C,E} = \frac{2.83089}{0.00250} = 1132 \text{ counts} \quad (37)$$

which is equivalent to a time interval of 2.8300 seconds for Earth orbit, and

$$C_{C,L} = \frac{3.65364}{0.00250} = 1461 \text{ counts} \quad (38)$$

which is equivalent to a time interval of 3.6525 seconds for lunar orbit.

The ratio of the  $285^\circ$  altitude-control travel to the 300-nautical-mile altitude range is 0.95 deg/n. mi. The ratio of the  $285^\circ$  altitude-control travel to the number of pulses (101 counts) is 2.8125 deg/count. These ratios are used to obtain the number of counts for the fine time counter as follows.

$$\frac{0.95 \text{ deg/n. mi.} \times (h - 10) \text{ n. mi.}}{2.8125 \text{ deg/count}} = 0.33777 (h - 10) + 1 \text{ counts} \quad (39)$$

The +1 count results from the fact that, at the zero encoder setting, a fine time interval of 1 is required for a trigger. The fixed time interval must be reduced by

0.00375 second (0.01875 second for lunar orbit) to account for the fine time interval required at an encoder setting of zero. The fixed time intervals for Earth and lunar orbit are therefore 2.82714 and 3.63489 seconds, respectively. The number of counts for the fine time counter  $C_F$  is

$$C_F = \frac{2.82714}{0.00250} = 1131 \text{ counts} \quad (40)$$

which is equivalent to a time interval of 2.8275 seconds for Earth orbit, and

$$C_F = \frac{3.63489}{0.00250} = 1454 \text{ counts} \quad (41)$$

which is equivalent to a time interval of 3.6350 seconds for lunar orbit. The fine time counter increments are related to the time period between stepper-motor output pulses by the following equations.

$$\tau_{STM,E} = 2.8275 + 0.00375C_F \quad (42)$$

and

$$\tau_{STM,L} = 3.6350 + 0.01875C_F \quad (43)$$

The accuracy of the ORDEAL output plus the ORDEAL panel is indicated in table VI. The required accuracy of the ORDEAL, as designated by NASA, is 2 deg/hr. From equation (12)

$$T = \frac{0.1}{\dot{B}} = \frac{0.1(\tau_{STM})}{\alpha} \quad (44)$$

Table VII is a comparison of the orbital period error, based on the theoretical  $\tau_{STM}/\alpha$  data in tables II and V. The allowance for resolver and gearing error is 20 angular minutes.

$$\frac{20'}{\frac{60 \text{ min/deg}}{2^\circ}} = 16.6 \text{ percent of total error allowed} \quad (45)$$

TABLE VI. - ACCURACY OF THE ORDEAL AND ORDEAL PANEL

(a) Earth orbit

h, n. mi.	$C_F$	$0.00375C_F$	Computed $\tau_{STM,E}$ , sec	Theoretical $\tau_{STM,E}$ , sec	$\epsilon$ , sec	$\epsilon$ , percent
10	1	0.00375	2.83125	2.8324	-0.00125	-0.04
85	26	.09750	2.9250	2.9258	-.0008	-.02
160	51	.19125	3.01875	3.0182	-.0016	-.05
235	<sup>a</sup> 76	.28500	3.11250	3.1156	-.0031	-.10
310	<sup>a</sup> 102	.38250	3.21000	3.2120	-.0020	-.10

(b) Lunar orbit

h, n. mi.	$C_F$	$0.01875C_F$	Computed $\tau_{STM,L}$ , sec	Theoretical $\tau_{STM,L}$ , sec	$\epsilon$ , sec	$\epsilon$ , percent
10	1	0.01875	3.65375	3.6786	-0.025	-0.69
85	26	.48750	4.12250	4.1258	-.003	-.07
160	51	.95625	4.59125	4.5612	.030	.65
235	<sup>a</sup> 76	1.4250	5.0600	5.0698	-.0098	-.19
310	<sup>a</sup> 102	1.9125	5.54750	5.56760	-.0200	-.36

<sup>a</sup>Values represent nearly one count of error.

TABLE VII. - ACCURACY OF THE ORBITAL PERIOD

h, n. mi.	Earth orbit		Lunar orbit	
	T, hr	Percent $\epsilon$ allowed	T, hr	Percent $\epsilon$ allowed
10	1.4162	0.78	1.8295	1.01
85	1.4629	.81	2.0632	1.15
160	1.5101	.84	2.2944	1.27
235	1.5578	.87	2.5358	1.41
310	1.6064	.89	2.7838	1.55

The allowance for frequency variation is

$$\frac{0.5}{400} = 0.125 \text{ percent variation} \quad (46)$$

The remaining error allowance may be budgeted for the shaft-rate error resulting from digital logic and approximation error. The errors are shown in table VIII.

TABLE VIII. - COMPARISON OF ALL ORDEAL ERRORS<sup>a</sup>

h, n. mi.	Earth orbit				Lunar orbit			
	$\epsilon_T$	$-\epsilon_G$	$-\epsilon_F$	$\epsilon_{SR}$	$\epsilon_T$	$-\epsilon_G$	$-\epsilon_F$	$\epsilon_{SR}$
10	0.78	0.13	0.13	0.52	1.01	0.17	0.13	0.70
85	.81	.13	.13	.55	1.15	.19	.13	.85
160	.84	.14	.13	.57	1.27	.21	.13	.93
235	.87	.14	.13	.60	1.41	.23	.13	1.05
310	.89	.15	.13	.61	1.55	.26	.13	1.16

<sup>a</sup>The errors are identified as follows:  $\epsilon_T$  = total error allowed,  $\epsilon_G$  = gearing and resolver error allowed.  $\epsilon_F$  = frequency error allowed, and  $\epsilon_{SR}$  = shaft-rate error allowed.

### SLEW CAPABILITY

The nominal  $\times 200$  (fast) and the  $\times 10$  (slow) slew rates are used to set the initial position of the resolver shaft. For simplicity, a nominal altitude of 160 nautical miles is used in computing the slew rates. (Deviations from the nominal will be negligible.) For Earth orbit at a 160-nautical-mile altitude

$$\tau_{STM, E} = 3.0182 \text{ sec} \quad (47)$$

$$\tau_{STM, E} = 0.30182 \text{ sec at the } \times 10 \text{ slew rate} \quad (48)$$

$$\tau_{STM, E} = 0.015091 \text{ sec at the } \times 200 \text{ slew rate} \quad (49)$$

The frequencies ( $1/\tau_{STM}$ ) for Earth orbit at the  $\times 10$  and  $\times 200$  slew rates are 0.67 and 13.3 deg/sec, respectively. For lunar orbit at a 160-nautical-mile altitude

$$\tau_{STM,L} = 4.5612 \text{ sec} \quad (50)$$

$$\tau_{STM,L} = 0.45612 \text{ sec at the } \times 10 \text{ slew rate} \quad (51)$$

$$\tau_{STM,L} = 0.022806 \text{ sec at the } \times 200 \text{ slew rate} \quad (52)$$

The frequencies for lunar orbit at the  $\times 10$  and  $\times 200$  slew rates are 0.44 and 8.76 deg/sec, respectively.

The median values (midway between the Earth and lunar values) are

$$\tau_{STM} = 0.364 \text{ sec at the } \times 10 \text{ slew rate} \quad (53)$$

$$\tau_{STM} = 0.0182 \text{ sec at the } \times 200 \text{ slew rate} \quad (54)$$

The slew rates at  $\times 10$  and  $\times 200$  are 0.55 and 11.00 deg/sec, respectively.

The fixed-interval time counter is used to obtain the slew rates directly. The use of the orbital-rate fine-adjust circuitry would introduce large variations in  $\tau_{STM}$  at the  $\times 200$  slew rates. Refer to figure 3(a) for the functional diagram of the slew-rate implementation.