

SPACE PROCESSING APPLICATIONS PAYLOAD EQUIPMENT STUDY

VOL. IIC. DATA ACQUISITION AND PROCESS CONTROL

DPD NO. 40
DR NO. MA-04
DCN NO. 1-3-21-00235
CONTRACT NO. NAS 8-28739

(NASA-12-14-74) ...
...
...
...
...

174-3433

1801

112

JULY 1974

M. KAYTON
A. G. SMITH (EDITOR)

PREPARED FOR

GEORGE C. MARSHALL SPACE FLIGHT CENTER
NATIONAL AERONAUTICS AND SPACE ADMINISTRATION
MARSHALL SPACE FLIGHT CENTER, ALABAMA 35812

BY

TRW
SYSTEMS GROUP

ONE SPACE PARK • REDONDO BEACH, CALIFORNIA 90278

FOREWORD

Phase II documentation prepared for the Requirements and Concepts for Space Processing Payload Equipment Study under Contract NAS 8-28938 resulted in a three-volume report. These volumes are as follows:

- Volume I. Executive Summary
- Volume II. Technical
 - IIA. Experiment Requirements
 - IIB. Payload Interface Analysis
 - IIC. Data Acquisition and Process Control
 - IID. SPA Kit
 - IIE. Commercial Equipment Utility
- Volume III. Programmatic and Payload Accommodation

Volume II, Technical, is published as five sub-volumes in order to facilitate presentation of topical groupings of data.

Phase I documentation was previously documented in 1973 as three volumes under the title, Requirements and Concepts for Materials Science and Manufacturing in Space.

One feature of this study has been the close association between the NASA Shuttle Sortie Working Group on Materials Science and Manufacturing in Space and the study contractor, TRW Systems Group. The NASA-MSFC study COR, Mr. Kenneth R. Taylor, has provided TRW Systems Group with working group documentation and, in turn, has coordinated study task results into the activities of the working group.

The TRW Systems Group personnel who assisted in the preparation of Volume IIC are listed below:

- Dr. M. Kayton
- Ms. A. G. Smith (Editor)

SPACE PROCESSING APPLICATIONS PAYLOAD EQUIPMENT STUDY

VOL. IIC. DATA ACQUISITION AND
PROCESS CONTROL

DPD NO. 40
DR NO. MA-04
DCN NO. 1-3-21-00235
CONTRACT NO. NAS 8-28938

JULY 1974

M. KAYTON
A. G. SMITH (EDITOR)

PREPARED FOR

GEORGE C. MARSHALL SPACE FLIGHT CENTER
NATIONAL AERONAUTICS AND SPACE ADMINISTRATION
MARSHALL SPACE FLIGHT CENTER, ALABAMA 35812

BY

TRW
SYSTEMS GROUP

ONE SPACE PARK • REDONDO BEACH, CALIFORNIA 90278

TABLE OF CONTENTS

	<u>Page</u>
1. SUMMARY	1
2. INTRODUCTION.	4
2.1 PURPOSE.	4
2.2 SPA INFORMATION PROCESSING REQUIREMENTS.	4
2.3 INFORMATION MANAGEMENT SYSTEM (IMS).	5
2.4 KEY ISSUES	7
2.4.1 Operational Issues.	7
2.4.2 Vehicle Design Issues	8
2.4.3 Design Issues	8
3. INFORMATION MANAGEMENT SYSTEM'S REQUIREMENTS FOR SPA PAYLOADS.	9
3.1 SERVICES ASSUMED BY THE SHUTTLE.	9
3.1.1 Payload Specialist Station.	9
3.1.2 Guidance, Navigation and Control (GNC) Computer	11
3.1.3 Performance Monitor Computer (PMC).	11
3.1.4 Telemetry	11
3.1.5 Electric Power.	13
3.2 SERVICES PROVIDED BY THE SPACELAB'S SUPPORT MODULE . .	13
3.2.1 Electric Power.	13
3.2.2 Display and Control Panels.	13
3.2.3 Subsystem Caution-And-Warning	16
3.2.4 Recording and Telemetry	16
3.2.5 Intercom.	20
3.2.6 Closed Circuit Television (CCTV).	20
3.2.7 Subsystem Computer and Data Transfer.	24

TABLE OF CONTENTS (CONT.)

	<u>Page</u>
3.2.8 Payload, Common-Support Computer and Data Transfer	30
3.2.9 Spacelab Operations.	31
3.3 SERVICES FURNISHED BY THE PAYLOAD EQUIPMENT	34
3.3.1 Services to Internal Payloads.	34
3.3.1.1 Lighting.	34
3.3.1.2 Master Payload Console.	34
3.3.1.3 SPA Payload-Dedicated Consoles.	35
3.3.1.4 Intercom Station.	35
3.3.1.5 Closed Circuit Television (CCTV).	35
3.3.1.6 Dedicated, Payload Computer	35
3.3.2 Services Furnished to the Cargo Bay.	37
3.3.3 SPA IMS Equipment List	37
3.3.4 Ground Support Equipment	40
4. CVT SUPPORT TO THE SPA DISCIPLINE	41
5. RECOMMENDED FUTURE WORK	44

LIST OF FIGURES

<u>Number</u>		<u>Page</u>
1	Spacelab Downlink Complex	12
2	Spacelab Electric Power	14
3	Spacelab Caution-Warning	18
4	Intercom.	21
5a	Remote Station Intercom Control Panel	22
5b	Master Station Intercom Control Panel	22
6	Close-Circuit Television.	23
7	Computers	25
8	CRT Format for a Typical SPA Experiment	28
9	CVT Support for Material Sciences Experiments	42

LIST OF TABLES

<u>Number</u>		<u>Page</u>
1	Subsystem Support Services Provided by the IMS. . .	2
2	Payload Support Services Provided by the IMS. . . .	3
3	SPA - Information Processing System Requirements. .	6
4	Payload Specialist Station.	10
5	Spacelab Crew Console Equipment	15
6	Warning Alarms in Spacelab.	17
7	Typical Data Rates of Exemplary SPA Experiments . .	19
8	Spacelab Flight Software Requirements 16-Bit Words. 26	
9	Clock and Digital Counters Requirements	29
10	Space Processing Payload's Software Requirements 16-Bit Words.	32
11	SPA Lab Operations.	33
12	SPA Payload's Cost of IMS Support	36
13	SPA IMS Equipment List.	38

ABBREVIATIONS USED IN THIS VOLUME

ACS	Air Conditioning System
CCTV	Closed Circuit Television
CPU	Central Processing Unit
CRT	Cathode Ray Tube
CVT	Concept Verification Testing
CW	Caution and Warning
EM	Experiment Module*
GMT	Greenwich Meridian Time
GNC	Guidance, Navigation and Control
GSE	Ground Support Equipment
IMS	Information Management System
IO	Input/Output
IOU	Input/Output Unit
KBD	Keyboard
LPS	Launch Processing System
MDM	Multiplexer/Demultiplexer
MM	Mass Memory
MUX	Multiplexer
PI	Principle Investigator
PCS	Process Control System
PMS	Performance Monitor System
RAU	Remote Acquisition Unit
SM	Support Module**
SPA	Space Processing Applications
STDN	Space Tracking and Data Network
TDRS	Tracking and Data Relay Satellite
XMTR	Transmitter

* This has since been retitled as the Experiment Segment.

**This has since been retitled as the Core Segment.

DATA ACQUISITION AND PROCESS CONTROL

1. SUMMARY

The Spacelab Information Management System (IMS) will tentatively provide the services shown in Table 1 to the host vehicle subsystems and those in Table 2 to the experiment payloads. Great emphasis is placed on crew safety and on achieving low cost by not excessively automating. The majority of these services can be provided by the common-support subsystems in the Support Module furnished by the Spacelab manufacturer at no cost to the payload. Others are provided by the SPA-furnished payload equipment. Table 3 in Section 2.3.3 gives a list of the equipment in each category.

The SPA payload will utilize the common-support 25 kbps recorders, telemetry, closed-circuit TV, Spacelab's payload-dedicated computer, master intercom and subsystem caution-and-warning. The SPA payload will furnish wiring and multiplexing equipment to transfer up to 12,200 bps from the experiments to the payload computer's input-output unit and 6000 bps of commands to the experiments, both within the capacity of the common-support equipment.

It has been estimated (see Section 3.3.3) that by using the common-support equipment and Spacelab-furnished interfaces, the Space Processing payloads need only furnish about \$4.5 million of new IMS hardware and software, compared to \$25 million if it furnished its own equivalent hardware.

No electronic ground support equipment is required for checkout after the Spacelab is loaded into the Shuttle.

Certain Spacelab requirements, especially the man-machine interfaces, should be determined in the CVT at NASA/MSFC where Spacelab crews, Shuttle crews, and future ground-based Principal Investigators can evaluate proposed designs prior to the Critical Design Review.

No new technology is required in the design of the Space Processing IMS.

Table 1. Tentative Subsystem Support Services Provided by the IMS

SAFETY

- Caution-and-Warning Panel for Level 1 and 2 Faults
- Audible and Visible CW Alarms

CHECKOUT

- Data Bus Collection of Subsystem Data and Console Switch Positions
- Crew and GSE See All Data
- Limit Checking for Diagnostics

RECORDING

- Continuous 5 kbps Interleaved
- Time Markers

DISPLAY

- Keyboard Selections of Formats
- Violation of Level 3 Limit Gives Instant Warning on CRT
- Subsystem Formats Recommend: Switching of Redundant Equipment Changes to Flight Plan

UPLINK AND DOWNLINK

- 5 kbps Interleaved Downlink Direct to STDN and Via TDRS
- 10^5 Bits of Uplink per Pass for Subsystem Program Changes

Table 2. Tentative Payload Support Services Provided by the INS

SAFETY

- TV Coverage of Interior and Post-Accident Recording
- Multiple Channel Voice Intercom
- Caution-and-Warning Panel for Level 1 and 2 Faults

CHECKOUT

- LPS Taps Computer and Sees all Data
- Automatic Sequencing (Non-Safety-Critical)
- Limit-Checking of Status Parameters

RECORDING

- Up to 20 kbps continuous Interleaved from SPA Experiments
- 1 mbps Recorder Not Used by SPA
- Voice Annotation
- Time Markers on All Recorders

COMPUTING

- 4000 Words Available for On-Board Processing
- Mass Memory Permits Reload of Additional Program. n Flight

DISPLAY AND CONTROL

- Diagnostic Formats
- Suggestions for Action in Case of Failure
- Quick-Look Experiment
- Keyboard Commands for Sequences and Formats

UNLINK AND DOWNLINK

- 20 kbps Interleaved Data on Downlink Continuously
- 256 kbps Downlink of Real-Time Experiment Data to STDN Slow Playback of 1 Mbps, Fast Playback of 25 kbps: Not Used by SPA
- 10^5 Bits of Uplink per Pass for Experiment Data Revise Computer Program and Insert Test Sequences

MULTIPLEX TERMINALS IN EACH CONSOLE

- 63 Discrete Monitors
- 15 Discrete Commands
- 31 Analog Monitors
- Self-Test

2. INTRODUCTION

2.1 PURPOSE

This report summarizes a part of the work performed under Task 2 - "Development of Preliminary Equipment Design" of the "Space Processing Applications Payload Equipment Study". The purpose of this task was to perform a design analysis on the major items of Space Processing Applications (SPA) payload equipment with emphasis placed on defining the interfaces with the host vehicle. The subtask of concern herein was that of performing a study leading to the definition of the requirements of data management and experiment process control and to match the SPA payload needs to the capabilities of both the Shuttle and Spacelab.

2.2 SPA INFORMATION PROCESSING REQUIREMENTS

The broad range of space experimentation and investigations of interest to the space processing discipline requires a large inventory of equipment and instrumentation. These have been grouped into what is called "subelements" which encompass modular groups of equipment that can be reconfigured in various ways to do different types of experiments. There are four experiment subelements (biological, furnace, general purpose, levitation⁽¹⁾) and one service subelement called the "core". It is only flown as a payload subelement to provide a common capability for one or more of the experiment subelements. The heart of this system is the information processing system which provides for data acquisition and for processing of data for control purposes.

The general requirements of the equipment is to accept output signals from equipment sensors, to convert them into compatible inputs and to

(1) For a description of these subelements, see Volume III.

monitor or store the data or act upon the data in a control mode. The equipment must work in both manual and automatic modes.

The equipment must also have experiment guidance capability. Procedural steps will appear on the CRT to guide the technician, who will then inform the computer when each step is completed. In this manner, human error will be minimized and the time required for each step will be recorded.

The data acquisition requirements are to accept and measure both AC or resistance signals and low level DC signals from measuring sensors such as thermocouples, strain gage bridges, pressure transducers, velocimeters, accelerometers, etc. Using a control network the experiments may be controlled as well as monitored.

The previous study defined a set of equipment items that were considered necessary as a part of the information processing system. These are listed in Table 3.

2.3 INFORMATION MANAGEMENT SYSTEM(IMS)

The Information Management System will consist of the following support services generally contained in the Spacelab Support Module:

- Closed-circuit television (CCTV)
- Intercom
- Caution-and-warning
- Electric power controls
- Information display
- Telemetry uplink and downlink
- Recording
- Data transfer
- Checkout, in-flight and preflight
- On-board data processing

Some of these services will be controlled by the on-board computers and some by the flight-crew.

Table 3. SPA - Information Processing System Requirements

DATA ACQUISITION UNIT

- Digital Clock
- Digital Voltmeter
- Multiplexer A/D Converter
- Printer (Output)
- Scanner Programmer
- Set Point Controller
- Signal Conditioner

DATA CONTROL UNIT

- Analog (SCR) Controller
- Digital Storage
- Input/Output Source
- Operator Control Unit
- Processor
- Storage Peripherals
- Tape Input
- Teleprinter

ELECTRO-OPTICAL IMAGING SYSTEM

- Automatic Processor
- CCTV Camera
- Camera Control Unit
- Frame Storage Unit
- Monitor
- Slow Scan Sync and Sweep

OSCILLOSCOPE

The Support Module as planned will support many different Experiment Modules. Individual Experiment Modules will be equipped with payload equipment to support various disciplines such as Space Processing, Plasma Physics, Solar Physics, Astronomy, Manned Earth Observations, Life Sciences and Communication - Navigation. Also planned are share missions which will include combinations of the listed disciplines. The Support Module is defined to include that IMS equipment that will be in common usage among the different disciplines, and it will be furnished by the Spacelab.

The SPA payloads will require a Support Module, an Experimental Module and a kit⁽¹⁾. The purpose of this report is to review the functions that are assumed to be performed by the common-support equipment and the additional services to be included as part of the SPA payload equipment.

2.4 KEY ISSUES

Several key issues concerned with methods of operation, vehicle design and IMS design have been identified and are currently under consideration. These issues must be resolved during the course of the design and are briefly presented here.

2.4.1 Operational Issues

A major issue being addressed is the question of how many Support Modules will be operational. On one side it is suggested that a single Support Module be designed to handle the needs of many different Experiment Modules with no individual modifications being performed between flights. The other view is that there should be an individual Support Module dedicated to each Experiment Module.

Another issue, which is not of major concern to the SPA discipline, is that of the capabilities of the STDN net. It has been suggested that it have the ability to demultiplex telemetry and television in order to present real/time data (5 minutes) to the Principal Investigator (PI) on the ground and also to furnish flight data to each within two weeks after landing.

Also at issue is the question of how much automation to provide to the experiments (i.e., the extent of crew operation of the experiments

(1) See Volume IID.

versus the extent of computer assistance). This decision must be made for both the manned Spacelab and the kit-only mode, in which the crew is at the Shuttle's Payload Specialist Station. The degree of automation for both pre-flight and in-flight conditions must be resolved. The amount of automatic sequencing must be decided as well as the extent to which automatic action is taken in case of a fault. Decisions such as these are best made in Concept Verification Testing (CVT), starting with a fully-manned laboratory and adding automation as the CVT shows it is needed.

2.4.2 Vehicle Design Issues

The issues concerned with vehicle design must be resolved prior to the detailed design of the IMS.

It must first be determined how much common-support equipment and software is to be furnished in the Spacelab at no cost to the experiment payloads.

The degree of autonomy of the SPA payload equipment with regard to dependence upon the Shuttle, Support Module and the ground must be established. The use of common-support equipment by the various experiment disciplines in principle reduces the cost of flight equipment development. On the other hand, this also complicates the interface definition and ground testing.

Layout and division of work among the crew stations, including the Shuttle's Payload Specialist Station, must be determined. These decisions are also best made in CVT.

Procurement rules must be formulated for the Spacelab's subsystem equipment with respect to parts selection and testing, quality control, documentation, post-flight analysis and mechanical/thermal environment.

2.4.3 Design Issues

There are two issues concerned with the design of the IMS itself. First, the extent to which the payloads will use the common-support computers, recorders, displays, etc., and the extent to which they should furnish their own equipment and software must be negotiated. The other issue is the determination of the number of signals to be transferred, recorded and downlinked.

3. INFORMATION MANAGEMENT SYSTEM'S REQUIREMENTS FOR SPA PAYLOADS

This section deals with the physical characteristics and associated costs of the IMS equipment necessary to the SPA payloads. It addresses the issue from the point of view of avionic equipment and details those services provided by the Shuttle, Spacelab and the payload equipment itself.

3.1 SERVICES ASSUMED BY THE SHUTTLE

The SPA payload equipment makes few demands upon the avionic equipment of the Shuttle. These demands are connected with the payload specialist station, guidance and control computer, performance monitor computer, telemetry and electric power. Each of these areas will be discussed separately below.

3.1.1 Payload Specialist Station

The functions that are assumed to be provided by the Shuttle Payload Specialist Station (PSS) are presented in Table 4. For kit-only missions, the PSS will control all subsystems and payloads. It will contain dedicated panels for each discipline payload aboard and caution-and-warning panels. It also will contain the computer-complex and its control panels, which is used for preflight checkout, in-flight checkout and monitoring, telemetry, and recording and monitors the Shuttle-furnished TV cameras that view the cargo bay.

For manned missions, the PSS is only indirectly concerned with the SPA payload since it controls the Shuttle side of the Shuttle-Spacelab interface. It controls incoming TV, voice and data as well as Spacelab-bound voice and uplinks. If Shuttle equipment (such as computers and mass-memories) is used to back up the Spacelab equipment, then the PSS will provide for necessary switching. The PSS has Spacelab subsystem panels that provide enough capability to start the lab prior to the first entry by the crew and to allow diagnostics in case the crew detects a Level 1 emergency and evacuates the Spacelab. The start-up and diagnostic function will require that the PSS contain caution-and-warning panels, keyboard and CRT, and subsystem panels for power and environment control.

Table 4. Possible Payload Specialist Station Functions

<u>CARGO BAY-ONLY</u>	<u>MANNED PAYLOADS</u>
PAYLOAD-DEDICATED PANELS	SPACELAB SERVICES ECLS POWER
SUBSYSTEM-DEDICATED PANELS	RADIATOR
SUBSYSTEM AND PAYLOAD CAUTION AND WARNING	SUBSYSTEM AND PAYLOAD CAUTION AND WARNING
CLOCK, GMT, GET, 2 EVENT TIMERS, 6 COUNTERS	CLOCK, GMT, GET, 2 EVENT TIMERS, 6 COUNTERS
SUBSYSTEM IMS CONTROL PANEL	SUBSYSTEM IMS CONTROL PANEL
PAYLOAD IMS CONTROL PANEL	BACKUP COMPUTER SWITCHING
CRT - KEYBOARD	CRT - KEYBOARD
25 KBPS RECORDER CONTROL PANEL	INTERCOM STATION AND SWITCHING PANEL
TELEMETRY TRANSFER PANEL	TELEMETRY SWITCHING PANEL
CCTV MONITOR	CCTV MONITOR
FUNCTION: OPERATE EXPERIMENTS	FUNCTION: CONTROL INTERFACE TO SUPPORT SPACELAB START-UP DIAGNOSIS FOR RE-OCCUPATION

No experiment panels need be furnished at the PSS. The division of functions between the PSS and the Support Module Station is not fully understood and should be definitized in CVT.

3.1.2 Guidance, Navigation and Control (GNC) Computer

The Shuttle's (GNC) computers will receive uplink from the ground containing time, state vectors and occasional program loads destined for one of the on-board computers.

The Spacelab's subsystem computer is assumed to receive data from the GNC computer via crosslinks from the redundant MDM's. The data will be transferred in a special format containing time, state vectors (best estimate as calculated in the Shuttle's GNC computer), attitude, and special loads directed to the Spacelab computers from the ground.

3.1.3 Performance Monitor Computer (PMC)

No interface will be necessary between the Shuttle's PMC and the Spacelab unless it is decided to use the former to back up the latter.

3.1.4 Telemetry

The assumed telemetry interface between the Spacelab and the Shuttle is shown in Figure 1. The payload experiments will generate 12 kbps of data as explained in a later section which is well within the 20 kbps capacity of the low bit-rate telemetry system to be furnished by the Spacelab. An interleaver will combine 5 kbps of subsystem telemetry and 20 kbps of experiment telemetry and transfer the interleaved bit stream into the Shuttle's PMC interleaver. It will then be mixed with other data and transmitted to the ground.

For some disciplines, high-speed data (256 kbps) will be transferred from any experiment or from a payload-furnished interleaver to the STDN. This capability will not be needed by SPA payloads due to their small data rates.

Closed-circuit TV can be downlinked via STDN whenever the Shuttle is in contact with a ground station. If a Principal Investigator desires continuous visual observation of specimens, then the TDRS must have K-band capability which is not in the present baseline.

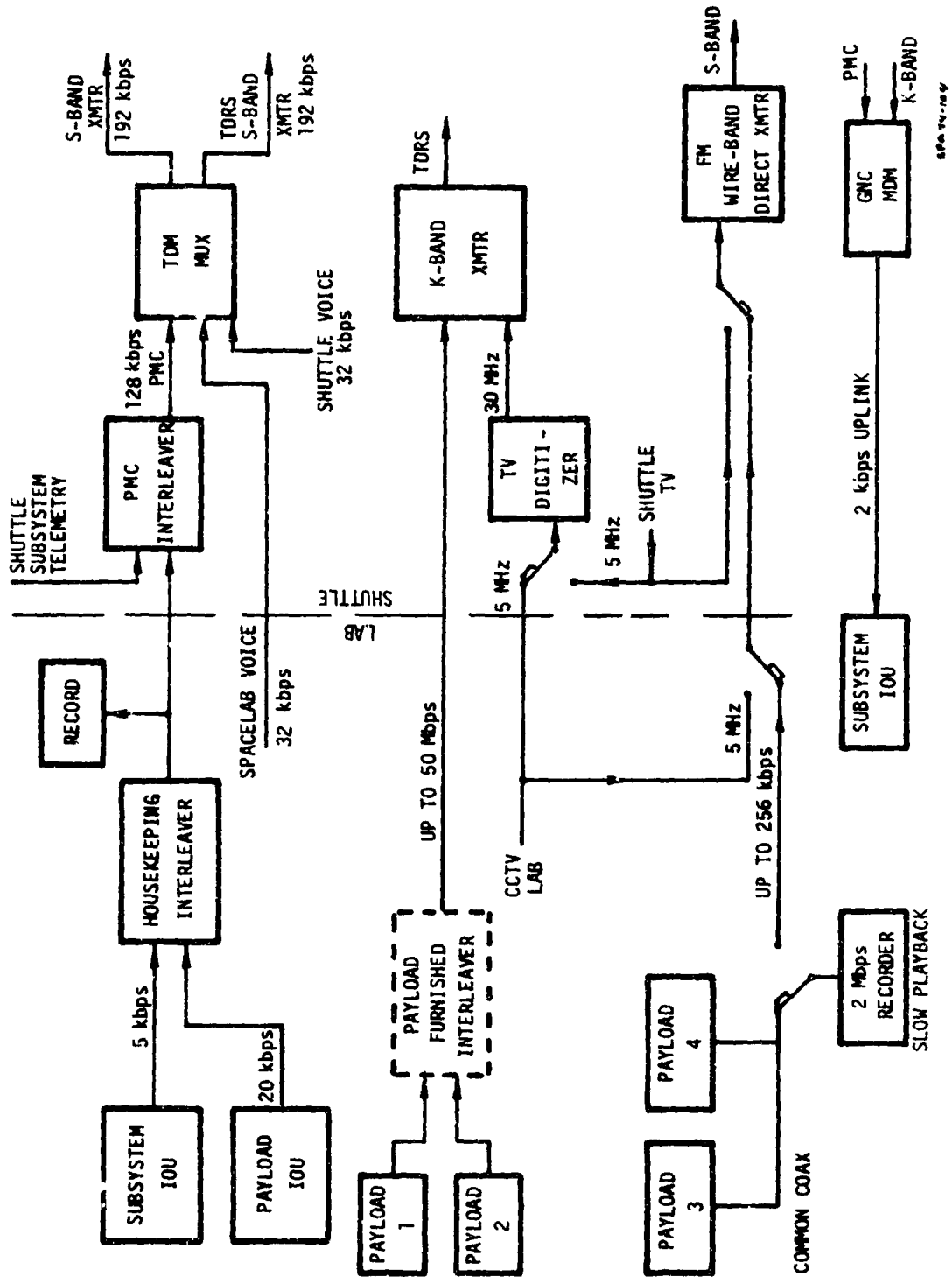

Figure 1. Spacelab Downlink Complex

3.1.5 Electric Power

The SPA payloads will need the maximum power available from the Shuttle (4 kW) and will supplement this when required. Seven kilowatts will be supplied but 3 kW will be used by the Spacelab Subsystems.

3.2 SERVICES PROVIDED BY THE SPACELAB'S SUPPORT MODULE

According to current expectations, the Support Module of the Spacelab will provide the services described below to the Space Processing payloads.

3.2.1 Electric Power

Of 7 kW of average electrical power generated by the Shuttle and distributed to the Support Module, it is assumed that 3 kW will be consumed by the Spacelab subsystems and that 4 kW will be available for distribution to the SPA payload. Electric power will be controlled by the Support Module's console operator (see Figure 2) and will be distributed. A fuel cell kit will be provided by the SPA payload and will be mounted in the cargo bay. It will provide power for automated payloads and the Experiment Module. The fuel cell controls and power distribution will be operated from the Support Module Station.

3.2.2 Display and Control Panels

The Support Module is assumed to contain a common-support equipment, display and control panel whose functions are shown in Table 5. These functions are summarized as follows:

- Control of electric power to each Spacelab subsystem and to the SPA payload.
- Control of cabin air conditioning within the support module and to the experiment module.
- Control of coolant to Spacelab subsystems.
- Control of lighting of the Support Module.
- Support Module caution-and-warning.
- Repeater panel from payload console's caution-and-warning.
- Repeater panel to Shuttle caution-and-warning.

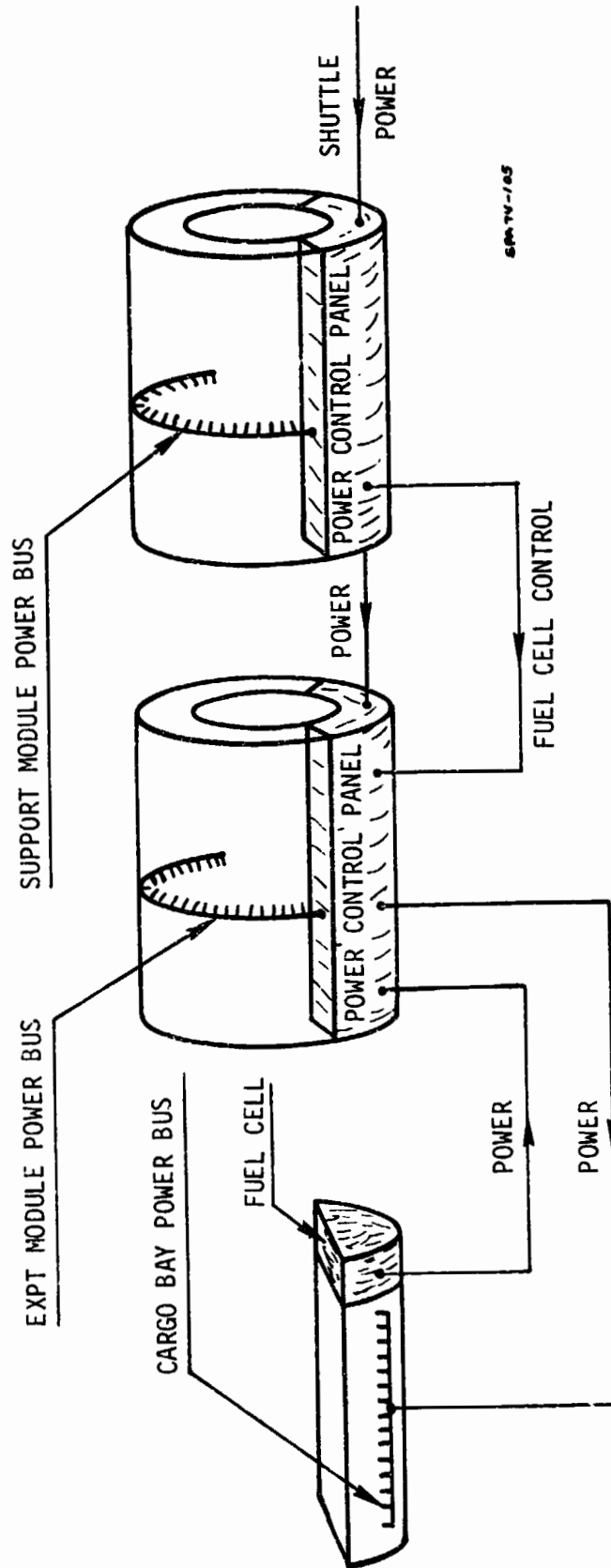

1. Distribution controlled from Support Module controls are in Experiment Module.

2. Power conversion in each box.

FIGURE 2. Spacelab Electric Power

Table 5. Spacelab Crew Console Equipment

<u>SUBSYSTEM STATION (ASTRONAUT)</u>	<u>PAYLOAD STATION (LAB TECHNICIAN)</u>
● SUBSYSTEM AND PAYLOAD CW	● SUBSYSTEM AND PAYLOAD CW
● SUBSYSTEM AND PAYLOAD KBD - CRT	● SUBSYSTEM AND PAYLOAD KBD - CRT
● CLOCK, GMT, GET, 2 EVENT TIMERS, 6 COUNTERS	● CLOCK, GMT, GET, 2 EVENT TIMERS, 6 COUNTERS
● 25 KBPS RECORDER CONTROL PANEL	
● SUBSYSTEM IMS CONTROL PANEL: COMPUTER, RAU, MM	
● PAYLOAD COMMON-SUPPORT IMS CONTROL PANEL	
● INTERCOM MASTER STATION	● INTERCOM STATION
● SUBSYSTEM-DEDICATED PANELS: AIR CONDITIONING, COOLING, POWER, LIGHTING	● PAYLOAD-DEDICATED PANELS
● TELEMETRY TRANSFER PANEL	● SUPPLEMENTARY-SUBSYSTEM PANELS FUEL CELL COMPUTER RECORDER RADIATOR
● ACS COMPUTER CONTROL PANEL	● ACS HAND CONTROLLER

- General purpose display for monitoring payload equipment.

3.2.3 Subsystem Caution-And-Warning

The Support Module contains a caution-and-warning (CW) system independent of the computer. It is predicated on the three levels of failure shown in Table 6. The implementation is shown in Figure 3.

1. Level-1 alarms are detected by CW and annunciated with a single light and alarm. The crew is expected to evacuate the Spacelab and use the Level-2 CW and the CRT at the Payload Specialist Station (PSS) to diagnose the fault.
2. Level-2 alarms are annunciated on a series of lamps, one for each subsystem. Crew action is to switch off the malfunctioning subsystem.
3. Level-3 alarms are detected only by the CRT display system. Crew action is to switch-off the malfunctioning equipment. The CW system supplies a signal to the intercom to actuate warning tones. Repeater panels are furnished at the Shuttle PSS and on the payload console of the Experiment Module.

3.2.4 Recording and Telemetry

Typical experiment data to be downlinked and recorded are shown in Table 7. Maximum data rates are no more than 12,200 bps and the data from the refrigerator, fuel cells and radiator may be another 400 bps. This is well within the 20 kbps experiment data channel furnished by the common-support equipment.

The 25 kbps recorder records an interleaved stream of 5 kbps of subsystem telemetry and up to 20 kbps of experiment telemetry, (mostly experiment housekeeping) annotated with time and attitude as shown in Figure 1 on Page 12. The formats will be determined by the software in the subsystem and payload computers.

Where intermittent telemetry exists to ground STDN station, reels will be saved throughout the flight. In the normal case of TDRS-relayed, continuous, S-band telemetry it is assumed that the tapes are saved only when telemetry is lost. This recorder is expected to serve the needs of most of the payloads. It obviates the need to run a complex, high-power recorder most of the time. Four hours of data can be recorded on a reel.

Table 6. Warning Alarms in Spacelab

<u>Level</u>		
I	Immediate Crew Hazard	Immediate Evacuation of Lab. Diagnose from PSS with Level 2 and 3 CW.
II	Crew Hazard if Prolonged < 5 Min	Use Level 2 CW to Diagnose/ Switch-Off Malfunctioning System.
IIIa	Long-Term Crew Hazard	Use Level 2 and 3 CW to Diagnose/ Switch-Off Malfunctioning System.
IIIb	Loss of Data	:

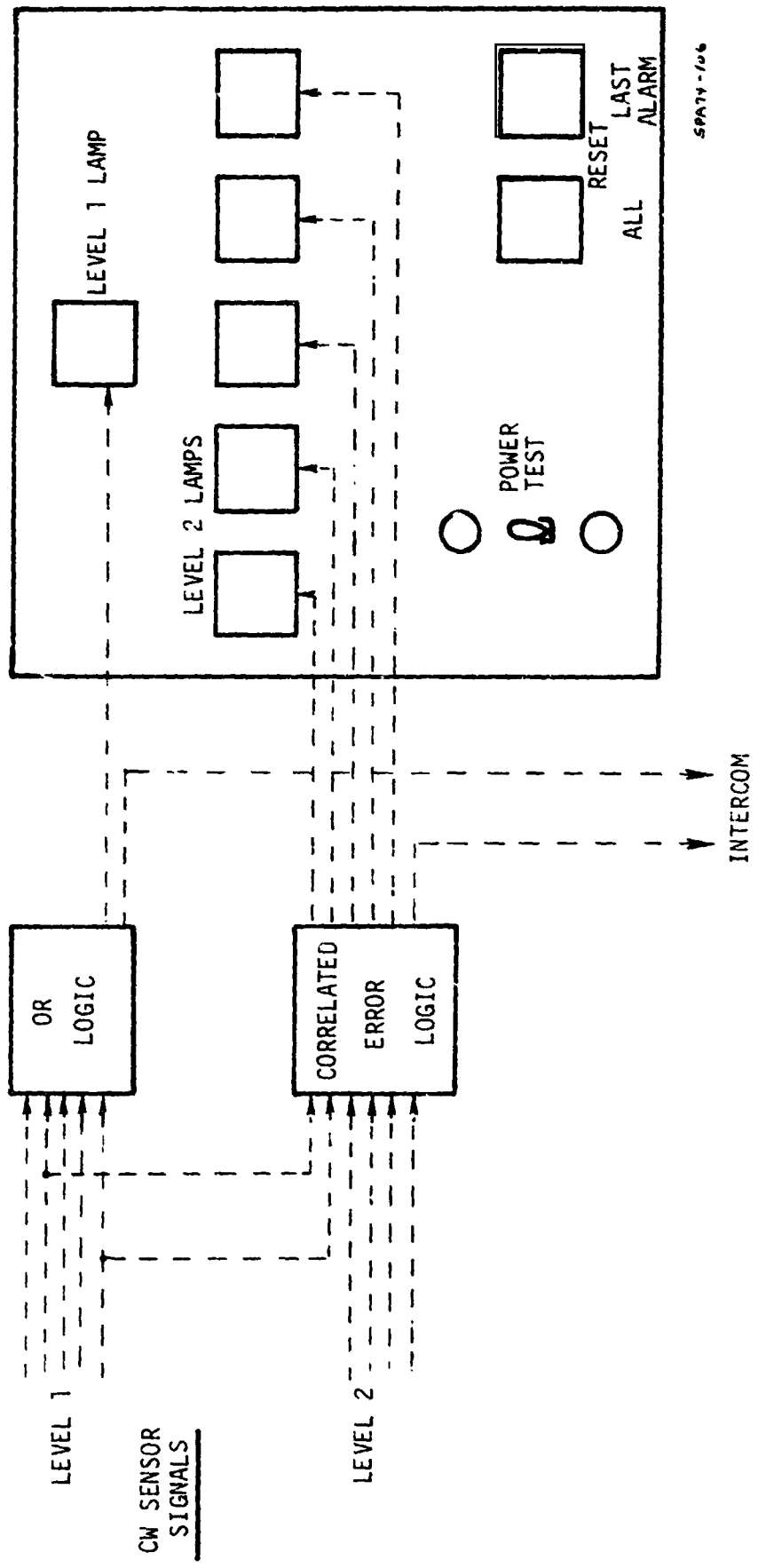

FIGURE 3. SpaceLab Caution-Warning

Table 7. Typical Data Rates of Exemplary SPA Experiments

No.	Exemplary SPA Experiment Class	R&D Category	Subelement	Max. Data Rate (bps)
1.	Encapsulated Immiscible Combination	Metallurgical	Furnace	208
2.	Preparation of Pure Alloys - Containerless Melting	Metallurgical	Levitation	12,106
3.	Molten Zone Crystal Growth	Crystal Growth	Furnace	86
4.	Crystal Growth by Pulling from a Containerless Melt	Crystal Growth	Levitation	12,236
5.	Preparation of Multiphase, Silicate-Based Glass	Glass Technology	Furnace	2,094
6.	Containerless Preparation of La_2O_3 -Based Glass	Glass Technology	Levitation	12,116
7.	Stationary Column Electrophoretic Separation of Proteins	Biology Applications	Biological	45
8.	Continuous Flow Electrophoretic Separation of Proteins	Biology Applications	Biological	94
9.	Containerless Position Control of Liquids by Electromagnetics	Physical Processes in Fluids	Levitation	12,050
10.	Thermal Gradient Convection in Liquids	Physical Processes in Fluids	General	0
11.	Chain Reactions Affected by Convection	Chemical Processes in Fluids	Levitation	12,040
12.	Radical Lifetimes	Chemical Processes in Fluids	General	60

The 25 kbps recorder can be downlinked at 10 times real-time on the 255 kbps channel directly to the STDN.

Two one-Mbps/channel Skylab recorders are planned for common support of the experiment payloads as shown in Figure 1. These recorders are connected to the payloads of disciplines that have high-data rate requirements by means of a coaxial cable. The SPA payloads will not need this capability.

3.2.5 Intercom

The intercom is described in Figure 4. It consists of two normal channels and one emergency channel. The emergency channel connects the Support Module, the Experiment Module, the airlock and the Shuttle PSS. It is always "on" and permits anyone to address a message to the entire crew by pushing the emergency button. It is independent of the normal intercom. The normal intercom is a two-channel telephone system with push button station calls. Each station can call any other or issue a vehicle-wide alarm. The main panel as shown in Figure 5b, and the PSS can address the loudspeaker located in the Spacelab module and in the airlock. The payload station has push-to-talk microphones. Six head sets are available in the Spacelab for use by the crew. The control panel for each payload station is shown in Figure 5a. It contains a volume control, jacks, call buttons and an emergency microphone. The master panel contains a channel selector, selective calling, volume control and channel coupling to loudspeakers and to the Shuttle. It also contains microphone and earphone amplifiers, channel summing amplifiers, tone-generators and the voice-recorder amplifiers. Any crew member may actuate the voice recorder in order to annotate the experiment with voice. There is visual indication of whether the channel is in use by another crew member. Playback of the tape while in flight is possible if the recorder is not in use. The PI will receive a copy of the tape after the mission.

The Shuttle PSS can connect either of the intercom channel channels to the Shuttle voice radio.

3.2.6 Closed-Circuit Television (CCTV)

A closed-circuit TV (CCTV) system will be furnished for safety surveillance and for accident investigation as shown in Figure 6. Two CCTV

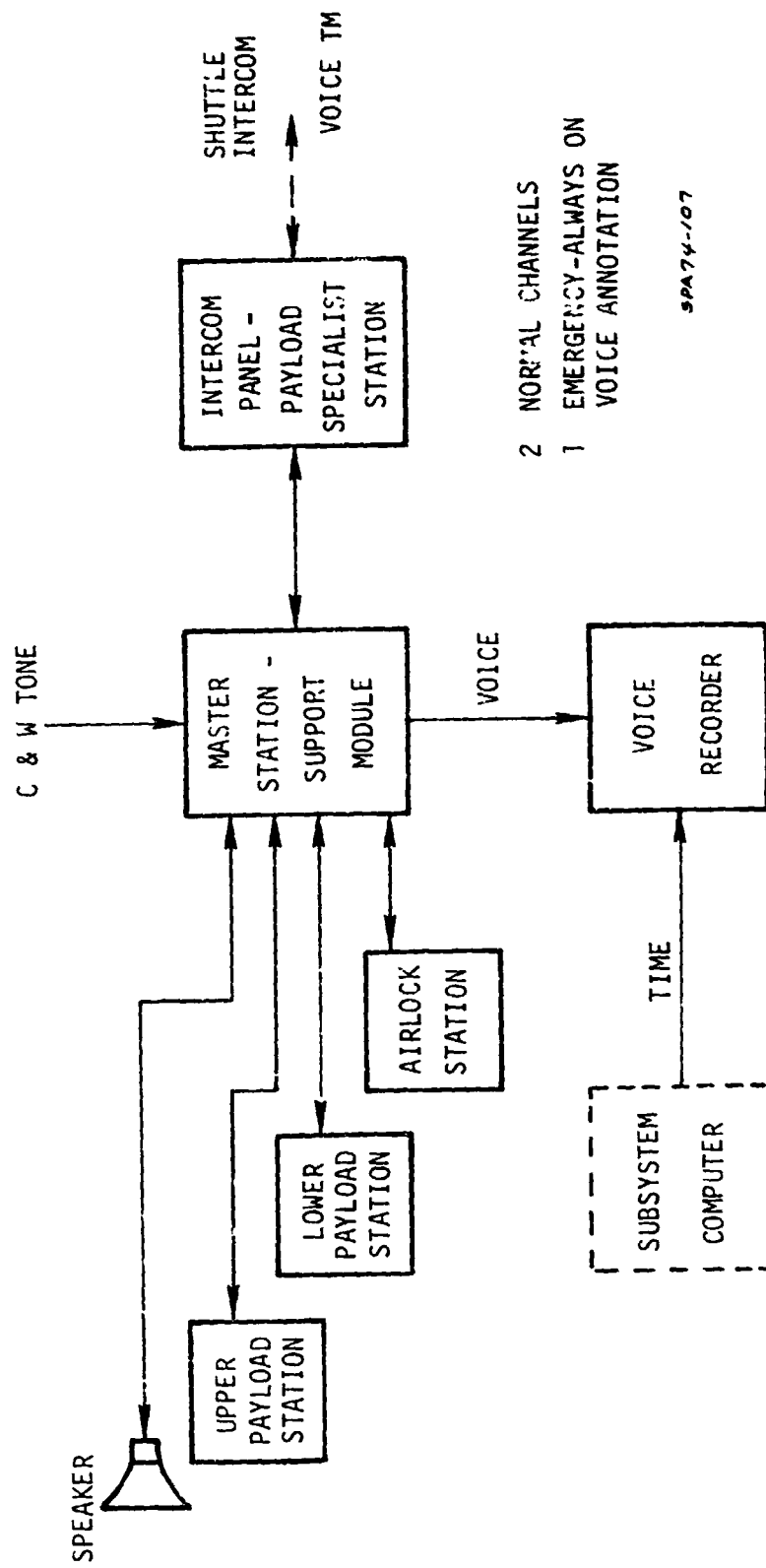

FIGURE 4. Intercom

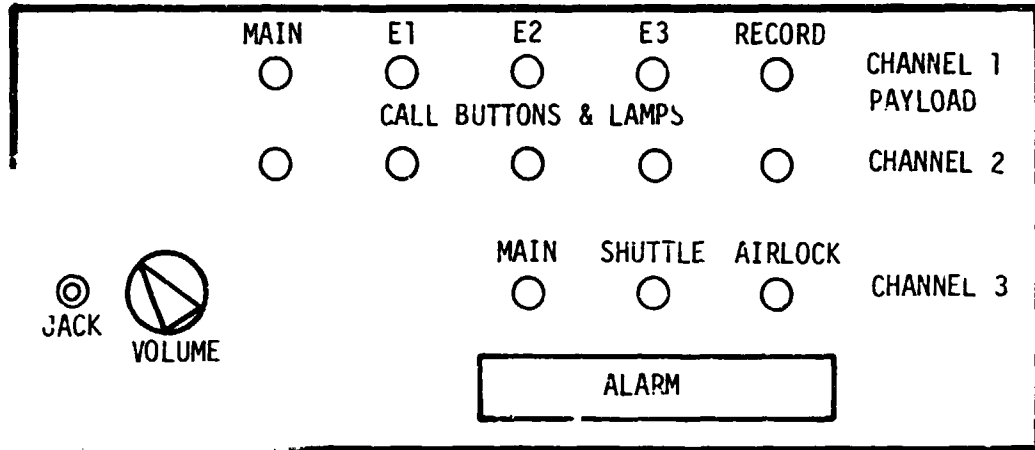
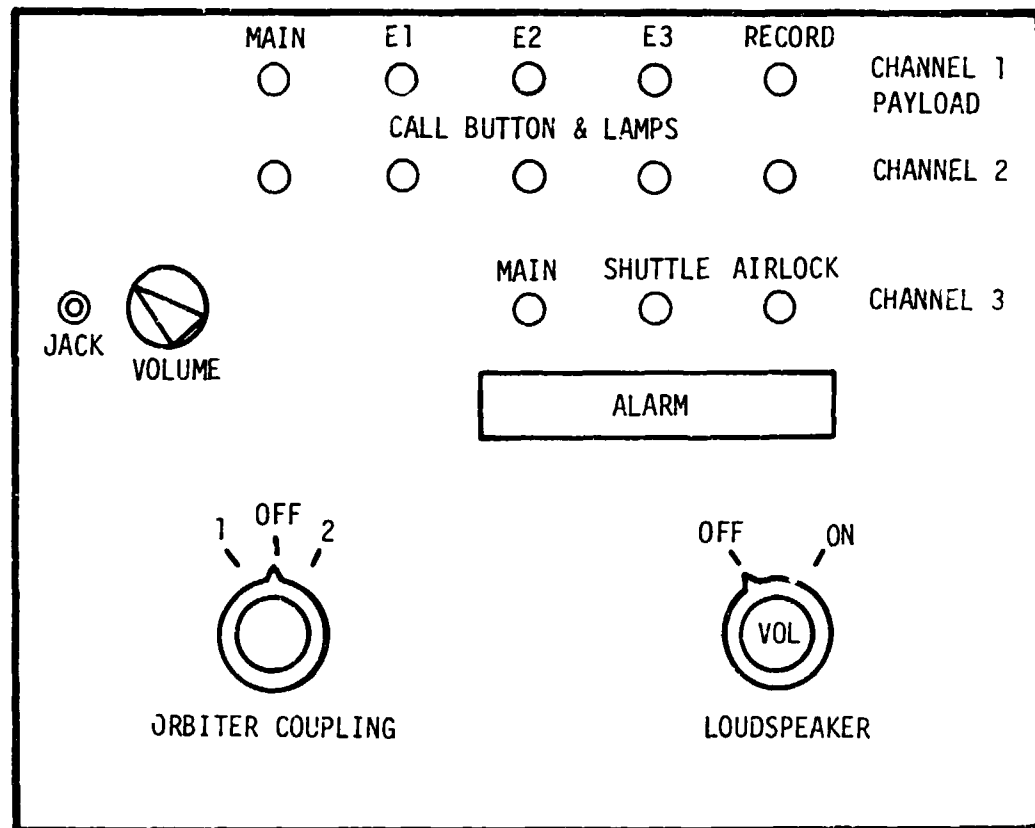

FIGURE 5a. Remote Station Intercom Control Panel



SMA 74-108

FIGURE 5b. Master Station Intercom Control Panel

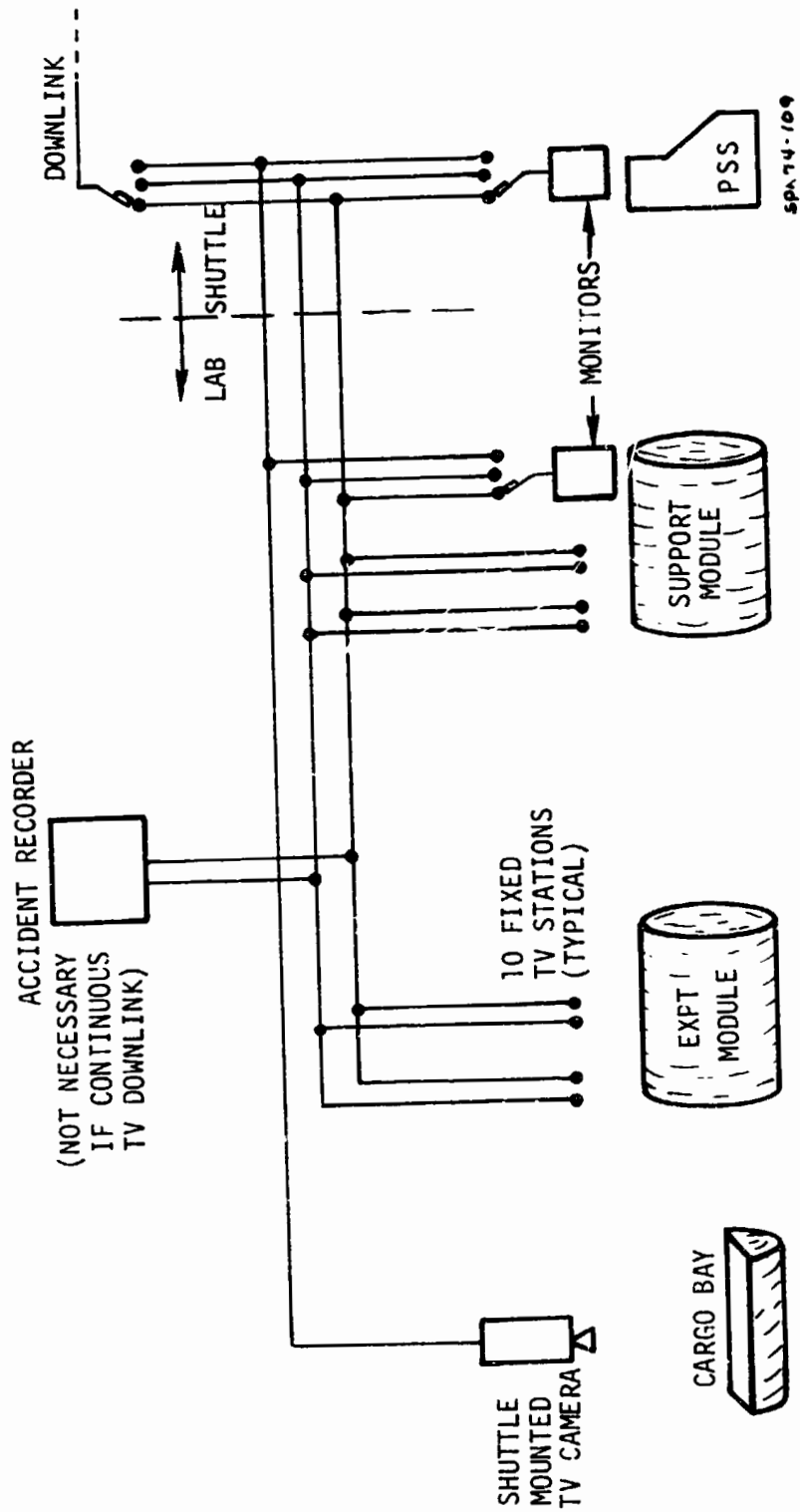

FIGURE 6. Closed-Circuit Television

channels will be furnished in the Experiment Module, one of which also services the Support Module. The two channels connect a series of fixed stations in front of each console and furnace at which a camera can be clamped in place. The camera will observe experiment activities and will either be downlinked continuously or recorded on a 30-minute-loop recorder. In case of an accident (for example, at a furnace) the recorder will provide a visual record of events if it is turned off within 30 minutes of the accident. Where continuous downlink is available, the recorder will be unnecessary. The downlinked TV will also be used for public affairs broadcasts and for providing cues to the PI on the ground for the overall supervision of the experiment.

The cameras will be self-contained with a 1-inch vidicon, 80° conical field of view and automatic light-level control from 3 to 1000 LUX. Two cameras will be provided, to be stowed in the Support Module when not in use. The downlink system will have adequate band-width for color.

The TV will be downlinked via S-band directly to STDN or via the TDRS K-band link, when the K-band link will be available. The TDRS S-band link is to be available in 1980 and will only accommodate low-power rate analog TV, as on Apollo. TV signals passing via TDRS will probably be digitized in the Shuttle, using the same equipment that digitizes the Shuttle's own TV, (see Figure 1.) Monitors will be provided by the Shuttle in the Shuttle's PSS and by the Spacelab at the Support Module Station. The Shuttle manufacturer will provide cameras on the interior of the payload bay that will provide surveillance of the cargo bay. These cameras will be connected to the monitor in the PSS as shown in Figure 6.

3.2.7 Subsystem Computer and Data Transfer

Figure 7 shows the subsystem computer and data transfer complex. Five kbps of data will emanate from the Spacelab subsystems and will be transferred by dedicated line and occasionally by multiplex lines to one of two computer input/output units (IOU). The data will arrive under software control and will be transferred to the computer which performs the functions, as shown in Table 8. The computer will be used for formatting, recording, telemetry, CRT displays, driving dedicated computers and for issuing non-safety commands.

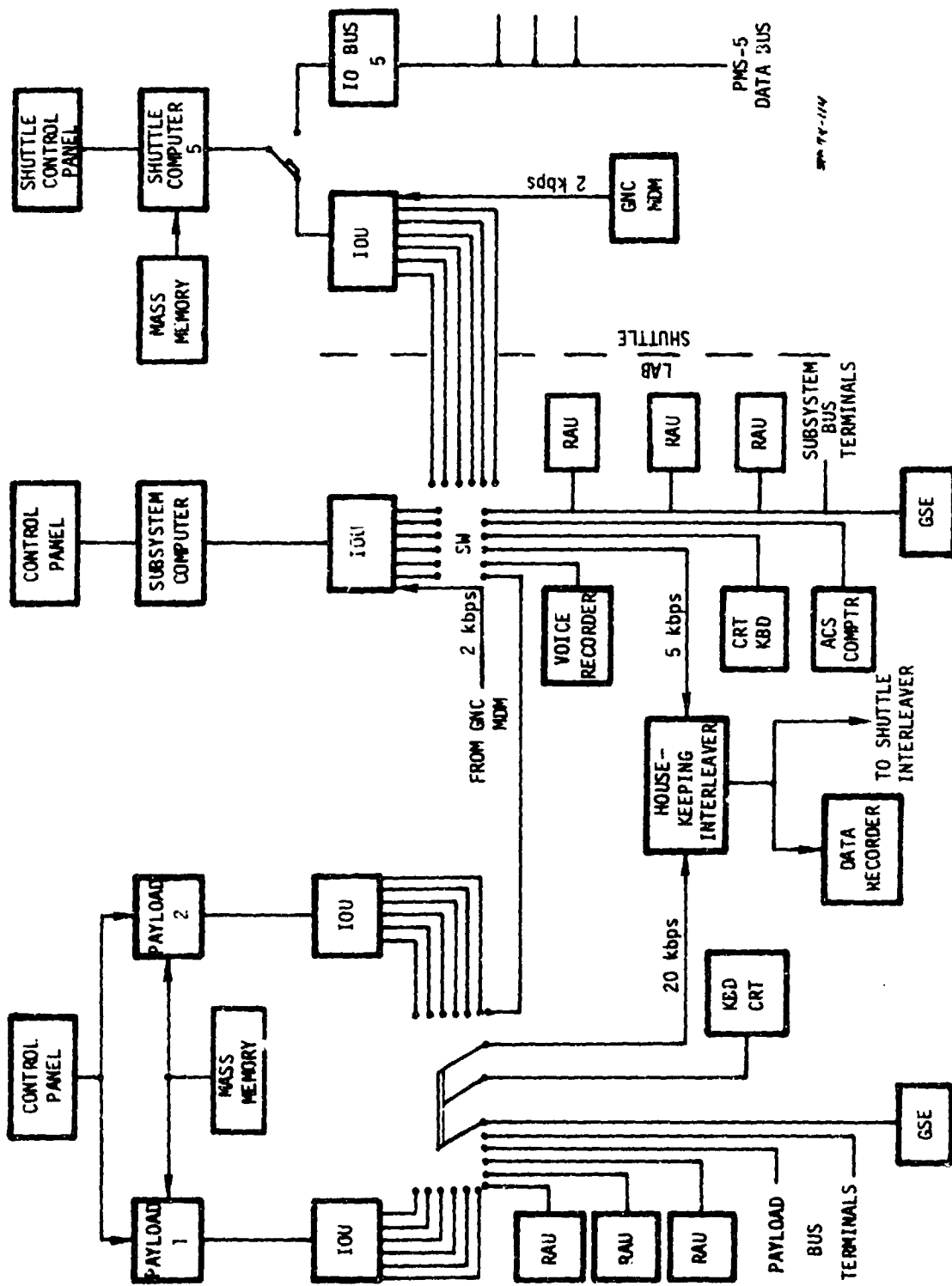

FIGURE 7. Computers

Table 8. Spacelab Flight Software Requirements
16 Bit Words

Functional Module	Subsystem Computer		Payload Computer	
	Data	Instruc.	Data	Instruc.
Executive	0	600	0	600
Bus Control (4 Formats)	2,000	500	2,000	500
Self-Test	100	1,000	100	1,000
Mass-Memory Control	0	Wired	0	Wired
Input Buffer	150	0	150	0
KBD-CRT Control	2,100	2,000	2,100	2,000
Crosslink Control	0	100	0	100
Computational Subroutines	0	200	0	300
Preflight Checkout (in the flight program)	2,600	600	1,500	500
Limit Checks and Diagnostics	1,200	100	5,000	200
Command Sequences	250	100	1,000	200
CRT Displays	4,000	1,000	10,000	1,000
Dedicated Displays (10)	50	100	50	100
Downlink Formats (2)	100	300	100	1,200
Recorder Formats	50	100	50	300
Contingency Action Messages	1,200	50	50	200
Preprocessing	0	0	5,000	2,000
	<u>13,800</u>	<u>6,750</u>	<u>31,050</u>	<u>10,200</u>
TOTAL		20,550		41,250

The computer functions are shown on Table 8 with the subsystem software sizing being shown in the first column of that table. The self-test routines will be provided by the computer manufacturer and will be included in the flight program. Mass-memory control is not in software but is wired in order to permit reloading after an in-flight loss of memory. Certain preflight checkout programs will be provided in the flight program in order that the reloading of the flight program not be required just prior to launch. Limit checks and diagnostics will be provided in order to check normal performance of subsystems and advise the crew when limits are exceeded. Non-safety commands may be issued by the computer. Non-safety commands are those that cannot compromise the crew's safety if prematurely issued, not issued or hard-over occurs. Because most subsystems will incorporate internal protection against faulty commands, we expect that the computer will be able to issue many commands such as programming the subsystems "on" and "off" at known times. Safety commands are not permitted to be issued by the computer to unprotected subsystems because in this design, the computers will not have adequate means of detecting their own failures and correcting them.

The software will be sized to deliver tabular formats to the CRTS, each of which will contain wired symbol generators, buffers and refresh electronics. The software will be adequate to show a different format on each of the 2 CRTS. The Spacelab will be furnished with an assembler, compiler, bit-by-bit emulator and editor for each of its computers, and it will be furnished with flight software for the subsystem computer.

A typical experiment-status format that might be created by the payload computer driving a CRT is shown in Figure 8. It is assumed that the software to create subsystem displays will be furnished with the Spacelab, but that the software for experiment displays will be furnished by the payloads. The cost of providing graphic displays, block diagrams and automatically reconfigurable tabular displays have not been included.

The computer will drive ten dedicated displays as shown in Table 9. These displays will show time, attitude, position and may be used as digital voltmeters for subsystems or experiments. Two downlink formats will be prepared by the software as well as one recorder format. Contingency action messages will be provided via the CRT. These formats will recommend

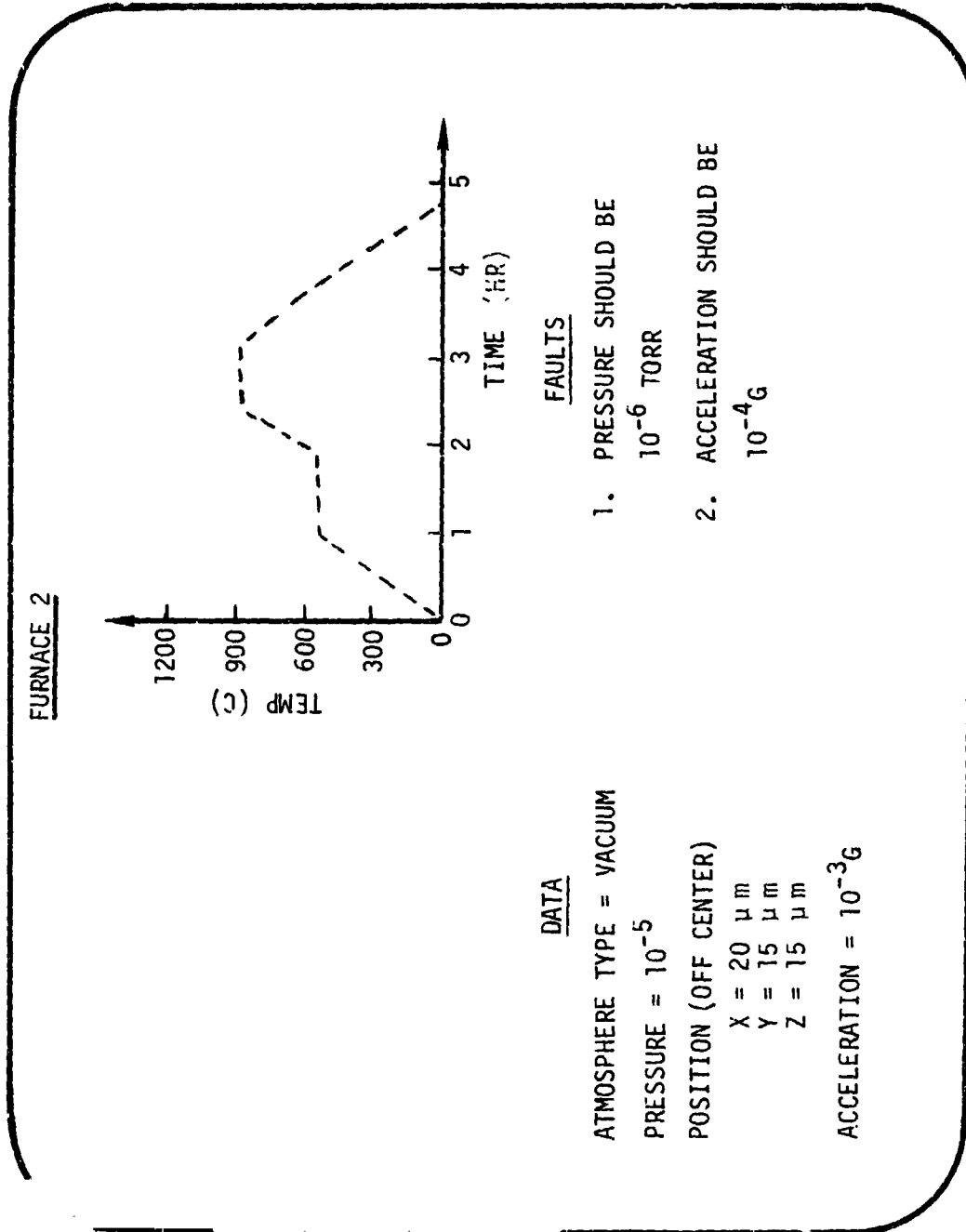

SPA 74-00

FIGURE 8. CRT Format for a Typical SPA Experiment

Table 9. Clock and Digital Counters Requirements

- NOT REQUIRED FOR SAFETY.
- TIME DERIVED FROM SPACELAB SUBSYSTEM COMPUTER, WHICH RECEIVES CLOCK UPDATES FROM ORBITER S/C COMPUTER.
 - a. GMT 8 DIGITS
 - b. GET 8 DIGITS
 - c. ELAPSED TIME (2) 5 DIGITS EACH, RESETTABLE
- SPARE COMPUTER-DRIVEN COUNTERS (6)
FOR POSITION, VELOCITY, ATTITUDE, VOLTMETER

actions to be taken in case of subsystem failure. It is assumed that an advanced logic state for subsystem contingency action messages will exist due to the large amount of experience accumulated by repetitive re-flying of the Support Modules.

Two identical subsystem computers will be provided. One is normally "on" and the other "off". In case of a computer failure, the crew must power-down the offending computer, turn-on and reload the spare from mass memory and put it on-line. This operation is estimated to take 15 minutes during which all subsystem computer functions are lost. This simple design was selected in preference to an automatic design because of the high cost and high risk of on-line redundancy and automatic switching. The program will be reloaded from a mass memory carried in the Spacelab. The mass memory is located in the Spacelab and probably will be the Odetics read-only recorder being developed for the Shuttle. The furnishing of a dedicated mass memory in the Spacelab simplifies the checkout of the lab by itself and simplifies the Shuttle interface. Each subsystem computer will have an associated input/output unit that connects it to the subsystems, to the keyboard and CRT, to the telemetry and recorder interleaver and to the payload computers (to which it sends time and uplinks changes to the program). As timing analyses become more exact, it may be possible to simplify the IOU and let the input/output be fully controlled by the CPU.

3.2.8 Payload Common-Support Computer and Data Transfer

Two redundant common-support computers will be provided in the Support Module for use by the payloads as shown in Figure 7. A star-connected net of wires collects data from the multiplex terminals in the payload consoles. The same data transfer system that will collect data from the payload equipment will also issue non-safety commands to them; therefore, oven temperature profiles can be issued from the computer because each oven has a protective internal mechanism for sensing over-temperature. Similarly, the computer can be used to close the loop between the magnetic levitation sensors and the sensor coils because failure of the levitation system causes no crew hazard.

The payload common-support computer will be sized for the functions shown in the second column of Table 8 in Section 3.2.7. The SPA payload will use it for the functions listed in Table 10 utilizing only a fraction of the available computing capacity. The functions are similar to those of the subsystem computer except that the common-support computer will be sized to do preprocessing to compress the data prior to telemetry and recording. For the SPA payload, preprocessing does not appear to be necessary. Contingency action messages will serve the same function as for the subsystem computer, but will be fewer in number because individual disciplines accumulate less flying time and less test time on which to develop the logic.

Table 7 shows that a computer of capacity of less than 32,000 16-bit words is adequate for the subsystem and for the payload computer. It appears that computer speed requirements will not be a problem for any 1974 aerospace computer. The applicability of mini-computers is discussed in Section 3.3.1.6.

As with the subsystem computers, two payload computers will be provided, one on-line and one off-line as shown in Figure 7. System failure detection and switching will be manual. It is expected that the same mass memory that will be used for reloading the subsystem computers will also reload the payload common-support computers. In some designs the Shuttle mass memory will reload the Spacelab computers and the Shuttle PMS-5 computer will back up one of the computers (payload or subsystem) in the Spacelab, a decision that simplifies the Spacelab hardware at the expense of a great increase in complexity of the interface and of the test procedures. Any of these designs will be acceptable for the SPA payloads.

3.2.9 Spacelab Operations

The Spacelab operations in the various stages of checkout and flight are shown in Table 11.

The crew will consist of an astronaut, who is the mission specialist and occupies a station in the Support Module. This individual is the prime operator of electric power, ECLS and connections to the Shuttle and may operate experiments of opportunity located in the Support Module (those which do not require electrical servicing). The division of activities between the Support Module Station operators (subsystems and

Table 10. Space Processing Payloads' Software Requirements, 16-Bit Words

	<u>Data</u>	<u>Instructions</u>
Executive	0	600
Bus Control: 8 consoles, 5 cargo-bay terminals	500	500
Self-Test	100	500
Mass Memory Control (wired)	0	0
Input Buffer for Crosslink	150	0
Crosslink Control	0	100
Computational Subroutines	0	200
KBD-CRT Control (external buffer)	300	200
CRT Formats (20 fixed, 20 variable, 100 measurements, 3 simultaneous)	7000	500
Dedicated Display Drive	50	100
Preflight Checkout Sequences and Monitoring	200	200
Limit Checks and Diagnostics (100 measurements)	3000	100
Command Sequences	200	200
Downlink Formats	100	300
Recorder Formats	50	150
Levitation Control	30	300
Contingency Action Message Tables	2500	200
Preprocessing	0	0
TOTAL	14,180	4,250
TOTAL WORDS		18,430

Table 11. SPA Lab Operations

1. HORIZONTAL CHECKOUT, ISOLATED LAB
 - CREW INSIDE LAB
 - ORBITER INTERFACE SIMULATOR
 - SUBSYSTEM CHECKOUT
 - EXPERIMENT CHECKOUT, WITH PRINCIPAL INVESTIGATOR
2. HORIZONTAL CHECKOUT IN ORBITER
 - CREW INSIDE LAB
 - VERIFY INTERFACES WITH ORBITER
3. VERTICAL ORBITER ON PAD
 - LAB UNMANNED
 - BIO REFRIGERATOR "ON"
 - LAB CAUTION AND WARNING ON
 - LPS MONITOR OF CAUTION WARNING
4. BOOST AND ENTRY
 - LAB UNMANNED
 - BIOLOGICAL REFRIGERATOR ON AND MONITORED BY CAUTION-AND-WARNING. STAYS COLD TWO HOURS: IF FAILS, NO NEED FOR IMS.
5. ON-ORBIT
 - COMPUTER-BUS CHECKOUT
 - POWER-UP SUBSYSTEMS
 - CREW ENTERS LAB
6. COMPUTER-BUS CHECKOUT PROCEDURE
 - A. COMPUTER HARDWARE SELF-CHECK
 - B. COMPUTER SOFTWARE SELF-CHECK
 - C. RAU POWER-UP ONE-BY-ONE; SELF TEST

payload) is suggested in Table 5 of Section 3.2.2 and the role of the Payload Specialist, though not well understood, is proposed in Table 4 of Section 3.1.1. Amplification of both kit-only experiments and manned experiments is provided there. The Principal Investigator (PI) will be on the ground. It will very seldom be required to have real time data to advise on the progress of the experiment and be able to direct the flight crew. The payload lab flight crew will consist of payload electromechanical technicians who are intimately familiar with the payload equipment. They will have a preplanned schedule of activity in flight (created in the CVT, Section 4) and may be advised by the PI's if changes to the preplanned activities become necessary. After the vehicle has landed, specimens and associated data will be removed in annotated containers and delivered to the Investigators. Data, voice and TV tape recordings will be sent to a data processing center for de-multiplexing and delivery to the PIs.

3.3 SERVICES FURNISHED BY THE PAYLOAD EQUIPMENT

This section describes the IMS services desired by the SPA discipline other than those furnished in the Support Module or Shuttle.

3.3.1 Services to Internal Payloads

The following services will be furnished by the payload equipment to the internal SPA payloads.

3.3.1.1 Lighting

Ambient lighting in the Support Module will be controlled from the subsystem console while ambient lights in the Experiment Module will be controlled from the payload console. Console lights will be controlled by each individual console. Emergency battery-operated lanterns, which switch on when power fails, will be provided in each module. Portable flashlights are desirable at various stations in both the Experiment and Support Modules.

3.3.1.2 Master Payload Console

This console in the Experiment Module will control lighting and contain an intercom station. It may also control ventilation and the distribution of electric power within the Experiment Module.

3.3.1.3 SPA Payload-Dedicated Consoles

Each payload discipline will furnish payload-dedicated IMS equipment in consoles having their own display and controls. The console will be connected to the circumferential electric power bus. It will contain a multiplex terminal that will supply data to the payload IOU and that will receive commands from the IOU via circumferential cable harnesses. It will contain adequate internal protection against unsafe commands from the computer or the crew.

3.3.1.4 Intercom Station

Because of the small floor size of the Experiment Module, one intercom station will be provided, furnished with a headset that can be carried throughout the module. A "record" button and an "in-use" light will be furnished on a hand-held line connected to the master payload console so the technician can use it to annotate the experiments. Figure 5, in Section 3.2.5, shows the intercom station that will consist of two normal channels and an emergency channel as described in that Section. A personal, battery-operated, voice recorder will be carried by the experimenters in order to record commentaries (without time annotation) for immediate use after returning.

3.3.1.5 Closed Circuit Television (CCTV)

CCTV will be furnished in the manner that is discussed in Section 3.2.6. The Experiment Module need only furnish camera mounting stations and wiring.

3.3.1.6 Dedicated Payload Computer

The SPA payload may prefer to use its own alternatives instead of the common-support computers. Table 12 compares the cost of using a dedicated computer versus using the common-support computer assuming equivalent development criteria. The cost of furnishing an independent mini-computer is still unknown because of the uncertainty in the mechanical and thermal environment that can be survived by a commercial mini-computer. The slow speeds and limited memory of the mini-computer are not expected to be a problem even when used to control the levitation of specimens.

Table 12. SPA Payload's Cost of IMS Support

	<u>Common- Support Equip.</u>	<u>Dedicated New Equip.</u>
Computer	\$ 0	\$ 5000K
Input-Output Adapter (IOU)	0	4000
Payload Multiplex Terminals (13)	260K	3000
Mass-Memory/Paper Tape Reader	0	2000
Computer-Complex Control Panel	0	800
Software	2000	2000
CCTV Camera, Monitor, Wiring	50	2000
Data CRT + KBD	1000	2000
Payload CW	200	2000
25 Kbps Data Recorder and Interleaver	0	1500
Personal Voice Recorder	100	100
IMS Integration	200	500
TOTAL	<u>\$1,410K</u>	<u>\$22,500K</u>

Assume both cases use common-support intercom, lighting and telemetry control.

Despite the electrical suitability of the mini-computer, its use is expected to be considerably more expensive in hardware and approximately equal in software to that of using the common-support computer.

3.3.2 Services Furnished to the Cargo Bay

The IMS services to the SPA Kit will consist of the sensing of signals and the issuing of commands. An estimated 5 multiplex terminals will receive discrete and analog signals from kit-mounted experiments and from the electric Power and Heat Rejection Kit (PHRK). The terminals will issue non-safety commands originating in the computer. Each terminal typically accepts 63 discrete signals and 31 analog signals (\pm 5 volts), the 64th and 32nd channels being used for internal tests. 15 discrete commands can be issued from each terminal.

An independent, non-multiplexed caution-and-warning system will accept approximately 100 signals from the automated payloads and PHRK for use in the Level 1 and Level 2 experiment caution-and-warning logic. Two CCTV cameras will be mounted in and furnished by the Shuttle to maintain surveillance of the cargo bay.

3.3.3 SPA IMS Equipment List

Table 13 lists the IMS equipment that will be used for the SPA payload equipment. The first column identifies the number of articles assumed to be furnished by the Spacelab as common-support equipment. The second column shows the number of articles that will be furnished by the payload. For example, multiplex terminals will be furnished in each payload equipment grouping to collect data going to the computer and to distribute commands. The circuits are assumed to be developed by the Spacelab manufacturer in order to assure compatibility with the IOU, but fabricated by the payload integrator.

CRTs and keyboards for the Experiment Module station are assumed to be furnished by the Spacelab manufacturer as are intercom stations, speakers and headsets. (If European funds are scarce, they may demand that these items be purchased by the payload integrator to drawings specified by the manufacturer.) The payload CW panel and its repeaters are furnished by the payload using the same circuits as for the subsystem CW.

Table 13. SPA IMS Equipment List

	<u>Common Support in Support Module</u>	<u>Furnished by Payload</u>
Computer and IOU		
Subsystem	2	0
Experiment	2	0
Multiplex Terminal (RAU)		
Subsystem	6	0
Experiment	0	13
Keyboard	2	0
CRT Display and Symbol Generator	2	0
TV Cameras and Brackets	2	0
TV Monitor	1	0
CCTV Brackets and Wiring	5	5
Intercom		
Master Station	1	0
Remote Station	1	0
Speaker	2	0
Headset	2	0
Voice Recorders	1	0
Lighting Controls	1	1
Interleaver	1	0
Orbiter Interface Panel	1	0
Computer Control Panel	2	0
Subsystem CW Panel	3	0
Payload CW Panel	0	3
Recorder and Telemetry Control Unit	1	0
GSE Interface Unit	1	0
Discrete Counter Panel	2	0
Personal Voice Recorder	0	1
25 kbps Recorder	1	0
High-Speed Recorder	0	0
Wiring	-	-
Power Control Panel	-	-

Table 12 shows the cost of developing SPA, payload-dedicated equipment instead of using the common-support equipment.

As an example, if the payload makes maximum use of common-support equipment, it need only supply \$4.5 million dollars worth of extra IMS equipment and software. On the other hand, if it wants its own computing and recording equipment, the payload must furnish an additional \$25 million dollars worth. These numbers are arrived at as follows:

- a. A payload common-support computer and IOU are furnished by the Europeans at no cost, however, if a minicomputer were adapted to the Spacelab environment, maintaining formal quality control and supplying NASA-expected paperwork, it would cost an estimated \$5 million for the computer and \$3 million for the IOU that connects it to the devices as shown in Figure 8.
- b. If a new data transfer scheme were to be developed, the multiplex terminals would rise in cost from \$100,000, for ten copies of a known design to \$5,000,000 for a new development, including qualification, integration, testing, etc. A paper-tape reader qualified to Spacelab standards would be needed in addition to the common-support mass memory and a control panel would be needed for computer, data-transfer and loading.
- c. Software is judged to be approximately equal whether a mini-computer is used, programmed in assembly language, or the European furnished AP-101 is used, programmed in a NASA-developed higher-order language. Software is needed for integrators of computer and peripherals (including the interface to the subsystem computer), experiment integration, launch-site check-out and flight.
- d. Using the common-support 25 kbps recorder for the 12.2 kbps experiment data will cost nothing because all formatting and interleaving will be Spacelab furnished. If, on the other hand, a dedicated payload data recorder were needed, it would have to be procured (perhaps also modified and qualified), a formatter would have to be designed and built and the units would have to be integrated. The cost would be approximately a million dollars.
- e. Development of an independent TV system is not recommended. Development of an independent CRT-KBD would cost at least \$3 million more than purchase of additional Spacelab-type units.

- f. Use of the circuitry for the Spacelab caution-and-warning might cost half that of developing new units. Because the caution-and-warning probably must meet the highest NASA quality standards, its costs may be understated.

It is presumed that Space Processing would not consider development of an independent intercom or telemetry control unit.

3.3.4 Ground Support Equipment

Space Processing will furnish electronic ground support equipment (EGSE) for use when the laboratory is horizontal and separated from the Shuttle. Integration and checkout will require use of standard laboratory test equipment, a procedure considered acceptable prior to mating with the Shuttle. Once the laboratory is loaded into the Shuttle, it is expected that all checkout can be done with on-board equipment; that is, there will be no need for EGSE when the loaded Shuttle is in a horizontal or vertical position on the pad. It is expected that the Launch Processing System (LPS) will monitor the Spacelab's caution-and-warning.

After mating with the Shuttle, the Spacelab subsystems are powered-up for an interface test with the Shuttle. After erection of the Shuttle to the vertical position, no subsystem activity is envisioned until the crew enters the lab on-orbit. Certain payload equipment (such as the refrigerator) will remain "on" through the preflight period. The caution-and-warning system will detect a failure (such as excessive temperature) and will make it known to the Payload Specialist and to ground personnel. Thus, the Launch Director will have enough information to decide whether to fly with reduced objectives or to hold.

4. CVT SUPPORT TO THE SPA DISCIPLINE

The SPA payload equipment would like to use the Concept Verification Testing (CVT) being developed by NASA/MSFC for the following purposes:

- Develop interface requirements among crew, experiments, core equipment, experiment equipment and Shuttle.
- Develop requirements for experiment-support software and for core equipment that are unique to Space Processing Payloads.
- Verify compatibility of hardware, software, real-time PI support and post-flight data reduction prior to flight.
- Develop flight procedures, timelines and contingency plans.
- Train crews in use of the hardware and software.

Figure 9 shows a suggested schedule of these activities.

The initial CVT runs are oriented to developing the extent of automation desired in the lab and the crew's interface with the lab for automated and manual equipment. During 1976, console configurations would be developed for the SPA equipment and also interface requirements to the common-support equipment would be defined. Results should be available in time for the Payload Critical Design Reviews in mid-1977.

Starting in 1977, a series of simulated-mission, one-week runs would be instituted to define the roles of the experiment operator, the common-support equipment operator and the Shuttle Payload Specialist. In 1978, refinement of the formats for downlink, recording and on-orbit display would occur. Real-time downlink formats, if necessary, can be defined by placing a PI in a room outside CVT, connected to CVT only by a voice, TV and data link. Several runs should serve to establish the kind of data needed by the PI to guide the flight crew in the performance of the experiment. Downlinked and recorded data formats for use after the flight can also be developed during the 1978 runs. In 1979, the effects of failures can be analyzed and a library of alternate missions can be created; thus, by the end of 1979, an ability to write the ground software and the flight software to support the missions will be verified.

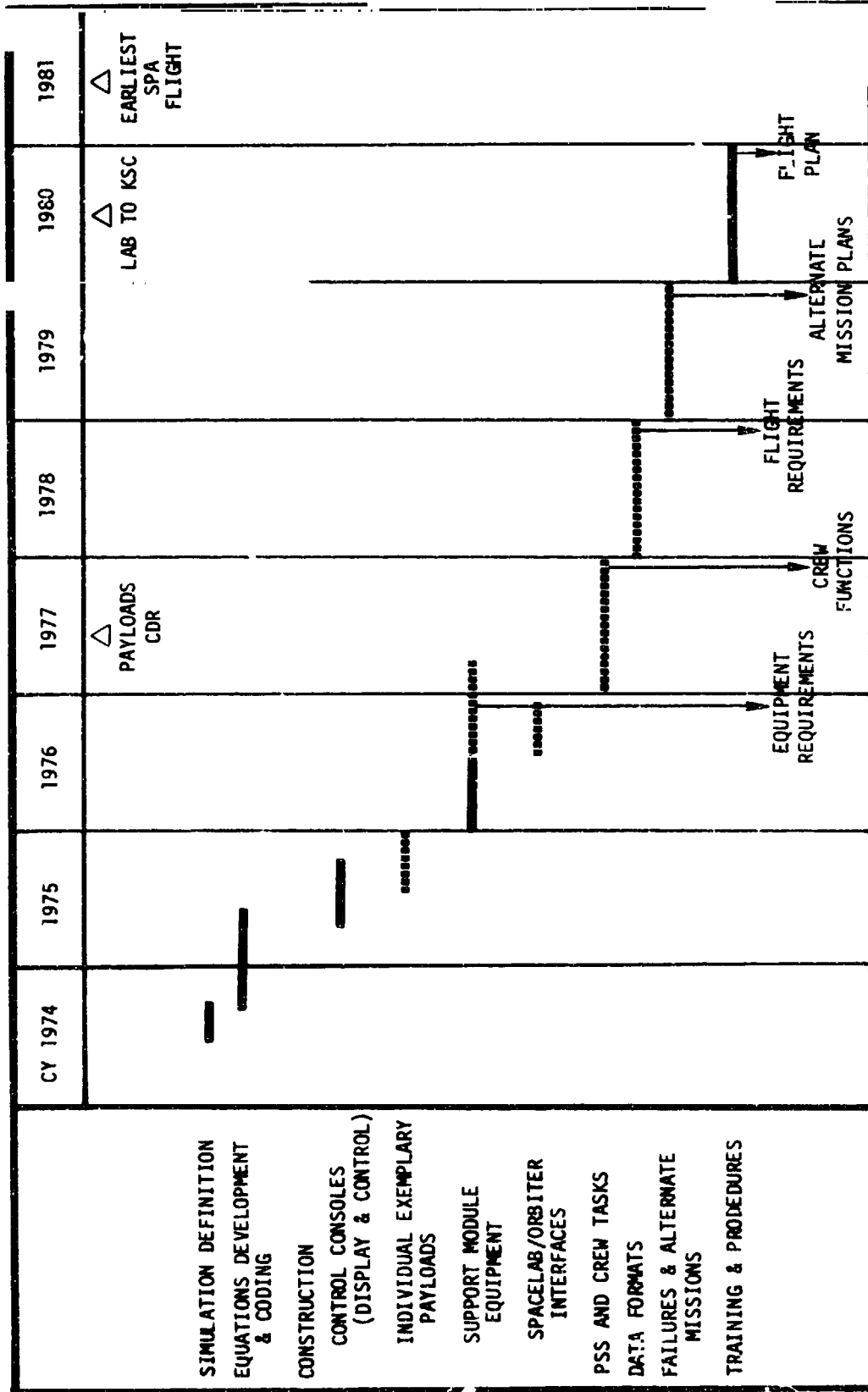

SPR 77-113

FIGURE 9. CVT Support for Space Processing Applications Payloads

Congruent with previous activities and CVT, by 1980, training of flight crews and development of mission-specific flight plans would begin in support of flight: that could start in mid CY '81.

5. RECOMMENDED FUTURE WORK

The design described in this report is a first attempt to develop an IMS for the Space Processing Payloads. The next steps are to define the requirements more precisely, then design alternative systems to meet those requirements and determine the physical properties and cost of each alternative. The final stage will consist of the selection of the "best alternative and detailed definition so that specifications may be written for its components.

Specifically, the recommended steps to follow are listed below:

1. Requirement definition. Simulated experiments should be performed in CVT to define the expected operational usage by the crew of the payload equipment. Questions such as the following should be answered.
 - a. Formats needed for the on-board displays, real-time downlink, post-flight downlink, recorder and caution-and-warning.
 - b. Experiment controls needed and amount of automation desired.
 - c. Need for microfilm viewer--how many and where.
 - d. Need for paper tape reader and printer.
 - e. Extent of reprogramming required in-flight -- by uplink or the crew.
 - f. On-board and ground data-processing algorithms desired.
2. Continued design of alternate systems, using varying amounts of Spacelab-furnished, common-support equipment versus payload autonomous items. The weight, power consumption, and cost of each alternate system should be calculated in more detail.
3. Improvement of software budgets and timing estimates - determine the properties of the desired flight computer; decide whether an external input-output unit is needed or if the CPU itself can control the IO traffic.
4. Subsystem design decisions such as color versus black-and-white

TV, cost of graphic displays on the CRTs and the need for internal diagnostics in experiments.

5. Feasibility of using commercially available IMS equipment in the Spacelab - anticipated modifications to meet the environment performance and interface requirements and the attendant costs.

6. Cost benefits of minicomputers - extent to which a minicomputer must be modified to meet the Spacelab IO and environment; comparison with the cost of using the Spacelab-furnished computers and of using dedicated aerospace computers. These costs must include software and test equipment.

7. Evaluate the data transfer rate within the vehicle - determine the method of transmission, error protection and multiplexer design.

8. Define more exactly the ability of the IMS to checkout and prepare the experiments prior to flight. Define the expected special test equipment needed to supplement the IMS.

9. Determine the schedule for design and procurement of the IMS hardware and software - the schedule should be compatible with flight dates, Spacelab deliveries and the CVT. (When must these commitments be made?)

Systems requirements should be transmitted to the Spacelab manufacturer before the PDR in February 1975 and subsystem requirements should be transmitted before mid-1976.