

NASA
HPD
pt.2
c.1(R)

LOAN COPY: RETURN TO
AFWL TECHNICAL LIBRARY
KIRTLAND AFB, NM

TECH LIBRARY KAFB, NM

0062864



1 OF 2

N74 34402 UNCLAS

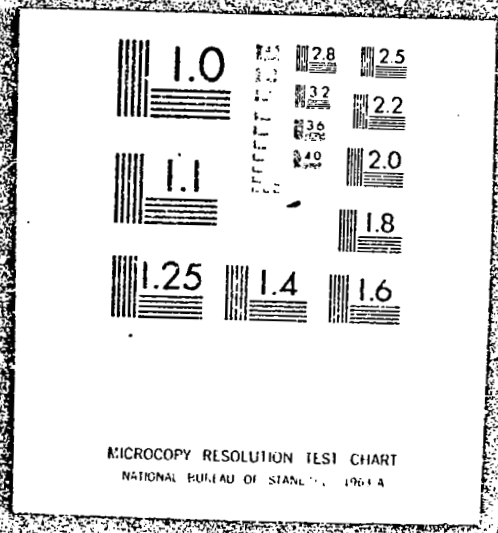

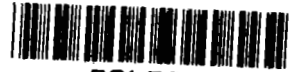

0062864

CR 134265

HEAT PIPE

DESIGN

HANDBOOK

PART II

PREPARED FOR

NASA

MANNED SPACECRAFT CENTER

HOUSTON, TEXAS, 77058

N74-34402

Unclas
G3/33 50117
CSCI 20M

(NASA-CR-134265) HEAT PIPE DESIGN
HANDBOOK, PART 2 (DYNATHERM CORP.,
Cockeysville, Md.) 150 p HC \$10.50

dynatherm

CORPORATION

Cockeysville, Maryland 21030

DRL-2
DRD No. SE-354T
DTM 72-3

HEAT PIPE DESIGN HANDBOOK

Contract No. NAS9-11927

August 1972

Prepared For
National Aeronautics and Space Administration
Manned Spacecraft Center
Houston, Texas

Prepared By
Dynatherm Corporation Engineering Staff

Submitted By *E. A. Skrabek*
E. A. Skrabek
Principal Investigator

Approved By *W. B. Bienert*
W. B. Bienert
Engineering Manager

C.1 HEAT PIPE ANALYSIS AND DESIGN CODE USER'S MANUAL

C.1.1 Introduction

This section describes the utilization of a digital computer code for Heat Pipe Analysis and Design (HPAD). Basically, HPAD calculates the steady-state, hydrodynamic heat transport capability of a heat pipe with a particular wick configuration and working fluid as a function of wick cross-sectional area. Heat load, orientation, operating temperature, and heat pipe geometry are specified. Both one "g" and zero "g" environments are considered. At the User's option, the code will also perform a weight analysis and calculate heat pipe temperature drops. Each of the following wick configurations whose cross-sections are shown in Figure C.1-1 can be analyzed using HPAD.

- Central Porous Slab
- Circumferential Porous Wick
- Arterial Wick
- Annular Wick
- Axial Rectangular Grooves

Both the composite and homogeneous modes of operation can be evaluated for the first three wick types. The analysis and formulation of the equations used in the program are presented in Section C.1.2. The basic closed-form solution for heat transport capability is presented, and the wick properties and self-priming requirements are established for each of the wick configurations. A weight analysis and a heat transfer model are also developed. This section concludes with the Method of Solution and User's options.

The program input requirements are described in Section C.1.3.2, and the output formats are described in Section C.1.3.3. Nomenclature is listed at the end of Section C.1.3. The flow diagrams, program listings, and sample problems are presented in the Appendices. A listing of FORTRAN names with engineering quantities is also presented as an Appendix.

Figure C.1-1. Heat Pipe Wick Configurations

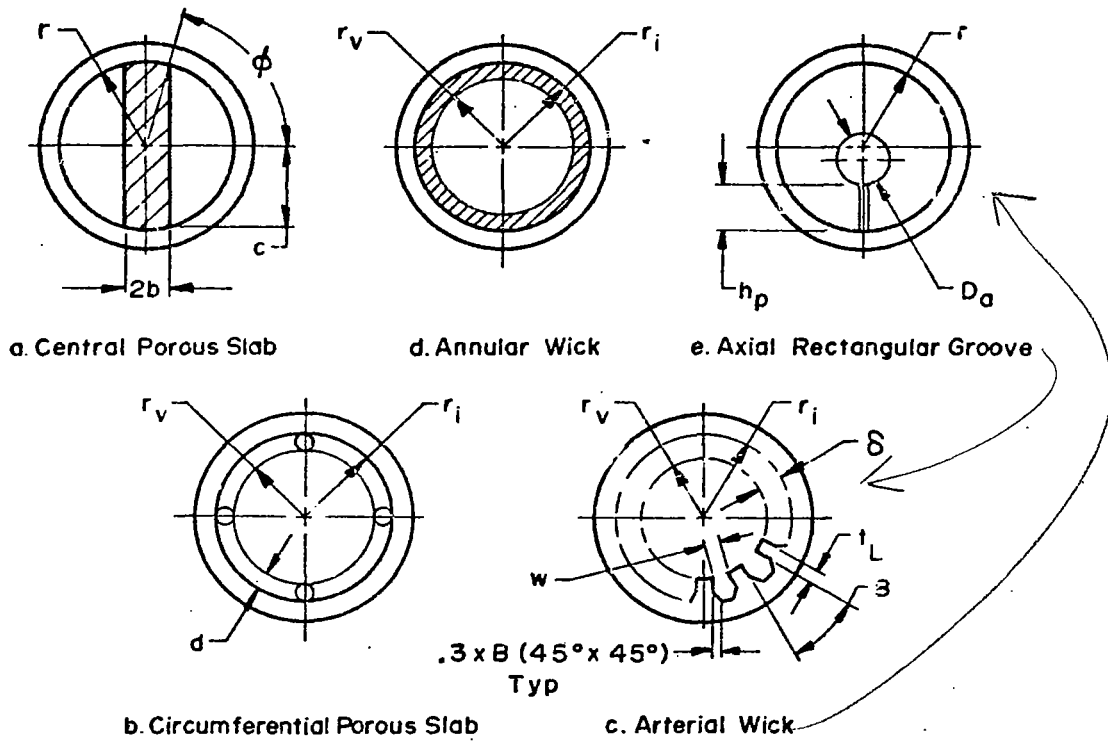

C.1.2 Analysis

C.1.2.1 Heat Transport Capability

The analysis to determine the heat transport capability of a heat pipe considers both capillary pumping and sonic vapor limits. Closed form solutions are used to predict the steady-state heat transport as a function of wick area in the case of the capillary pumping limit or the minimum vapor area for the sonic vapor limit. The analysis is performed for the conventional one-dimensional heat pipe shown in Figure C.1-2. The following assumptions apply:

- Uniform heat addition and removal at a single evaporator and condenser section.
- Uniform wick properties and circular cross-section over the entire length.
- Momentum effects are negligible.

C.1.2.1.1 Capillary Pumping Limit

The closed-form solution for the hydrodynamic heat transport capability as determined by the capillary pumping limit can be derived as:

$$\dot{Q}_t = \frac{2 K A_w (1 + \eta) \cos \theta F_1}{r_p L_{\text{eff}}} N_1 \quad \text{C.1-1}$$

Although the individual terms have been discussed previously they will be repeated here for easy reference.

1. The parameter η is defined as the ratio of the sum of all pressure differences due to body forces to the available capillary pressure, i. e.,

$$\eta = - \frac{r_p D \cos \beta}{2 H \cos \theta} + \frac{r_p h}{2 H \cos \theta} \quad \text{C.1-2}$$

where H , the wicking height factor, is a property of the working

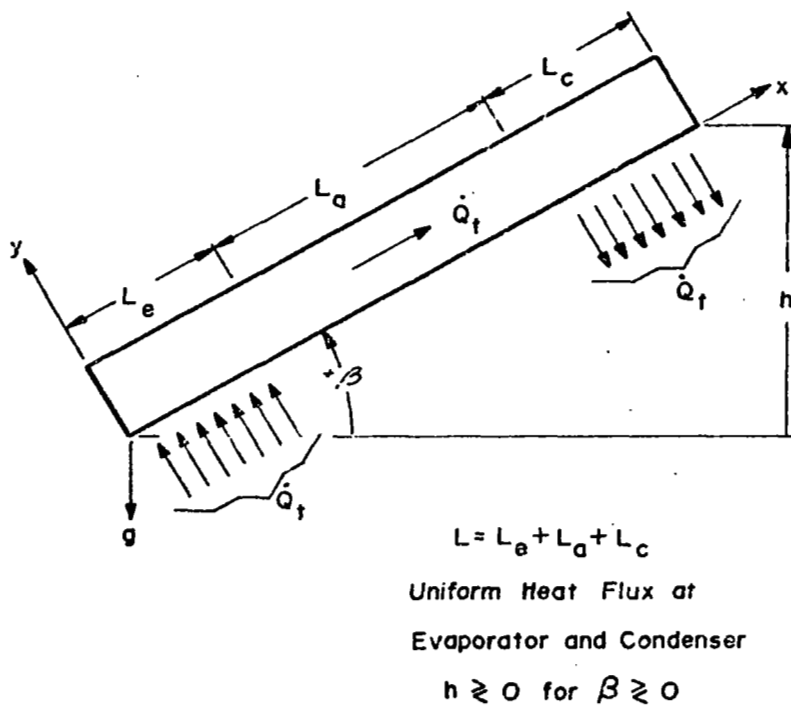

Figure C.1-2. Conventional Heat Pipe

fluid and is defined as:

$$H = \frac{\sigma}{\rho_1 g} \quad \text{C.1-3}$$

2. The parameter F_1 represents the ratio of the flow pressure drop in the liquid to the sum of the flow pressure drops in liquid and vapor.

$$F_1 = \frac{\Delta P_1}{\Delta P_1 + \Delta P_v} = \frac{1}{1 + \phi \frac{\nu_v}{\nu_1} \frac{32 K}{D_{h,v}^2} \frac{A_w}{A_v}} \quad \text{C.1-4}$$

where the factor ϕ depends on whether the vapor flow is laminar or turbulent.

$$\phi = \begin{cases} 1 & , \text{Re}_v \leq 2200 \\ 0.0031 (\text{Re}_v)^{0.75} & , \text{Re}_v > 2200 \end{cases} \quad \text{C.1-5}$$

with

$$\text{Re}_v = \left(\frac{\rho v D}{\mu} \right)_v \quad \text{C.1-6}$$

The turbulence coefficient (0.0031) has been adjusted so that the total vapor pressure drop neglecting momentum effect is equal for the laminar and turbulence at $\text{Re}_v = 2200$. This assumption gives a smooth transition from laminar flow to turbulence. The maximum deviation resulting from the above assumption is about 10%.

3. The Liquid Transport Factor N_1 is defined as:

$$N_1 = \frac{\rho_1 \sigma \lambda}{\mu_1} \quad \text{C.1-7}$$

4. The parameter L_{eff} is the effective transport length defined as:

$$L_{\text{eff}} = \frac{L_e + L_c}{2} + L_a \quad \text{C.1-8}$$

5. The parameters K , r_p , $D_{h,v}$, A_w , and A_v are the permeability, effective pumping radius, vapor hydraulic diameter, and the wick and vapor cross-sectional areas, respectively. These parameters are defined by the type of wick material and wick geometry employed. Homogeneous and composite type wicks are treated by determining the appropriate values of permeability and pumping radius to be used in Equations C.1-1 and C.1-2. Equivalent wick properties for different wick geometries are discussed in a later section.

Once the properties of the wick and working fluid have been determined, Equation C.1-1 is used to calculate the maximum heat (\dot{Q}_t) that can be transported without exceeding the capillary limit. When the vapor flow is laminar, Equation C.1-1 can be solved explicitly for either $\dot{Q}_t L_{\text{eff}}$ or \dot{Q}_t . When the flow is turbulent, Equation C.1-1 becomes an implicit relation for \dot{Q}_t . In this case, the Newton-Raphson Method is used to calculate the maximum heat transport.

The heat transport capability is calculated for both zero "g" and one "g" environments by setting η equal to zero for the former and calculating η (Equation C.1-2) for a specified elevation h_e (equal to $-h$) in the latter. The variation of heat transport with evaporator elevation ($d\dot{Q}_t/dh_e$) is also calculated for the one "g" laminar case from:

$$\frac{d\dot{Q}_t}{dh_e} = - \frac{K A_w F_l N_l}{L_{\text{eff}} H} \quad \text{C.1-9}$$

In order that a particular wick performs to its full capacity in a gravity field, it must be capable of complete self-priming. At a minimum, this requires that in the static condition and at the specified orientation the capillary pumping available during priming must be sufficient to overcome any adverse body forces. Thus, for a fully saturated wick, the gravity head required for self-priming becomes:

$$h_{\text{req}} = h_e + D \quad \text{C.1-10}$$

In the analysis, the self-priming capability of a particular wick is determined from:

$$h_{sp} = \frac{2 H \cos \theta}{r_{p, sp}} \quad \text{C.1-11}$$

where $r_{p, sp}$ = effective pumping radius during filling. Thus, in order to have a fully saturated wick:

$$h_{sp} \geq h_{req} \quad \text{C.1-12}$$

This program will calculate the heat transport capability for only those wick geometries which satisfy the self-priming requirement (i. e., Equation C.1-12). As an example, consider the case of an arterial wick (Figure C.1-1C) adjacent to the tube wall ($h_p = 0$). The self-priming requirement for a horizontal heat pipe with this wick is:

$$h_{req} = D_a \quad \text{C.1-13}$$

During priming the effective pumping radius is:

$$r_{p, sp} = \frac{D_a}{2} \quad \text{C.1-14}$$

therefore:

$$h_{sp} = \frac{4 H \cos \theta}{D_a} \quad \text{C.1-15}$$

The code will therefore perform the heat transport analysis for increasing values of artery diameter until either:

$$D_a > 2\sqrt{H \cos \theta} \quad \text{C.1-16}$$

or the sonic vapor limit or the maximum allowable vapor temperature drop is exceeded.

C.1.2.1.2 Sonic Vapor Limit

Generally, the heat transport capability of a heat pipe will be determined by the capillary pumping limit; however, in those cases where the working fluid is at a low vapor pressure, the sonic vapor limit could become dominant. The minimum allowable vapor area that can exist without incurring the sonic vapor limit is calculated from:

$$A_{v, \min} = \dot{Q}_t \sqrt{\frac{2(\gamma+1)}{\gamma R_g T}} \frac{1}{\rho_v \lambda} \quad \text{C.1-17}$$

When performing the heat transport analysis for a specified wick configuration, the transport capability calculated from Equation C.1-1 is a function of increasing wick (i. e., liquid) area until the wick becomes so thick that the vapor flow area is reduced to the point where the sonic vapor limit is reached. The heat transport portion of the analysis is then terminated. The analysis is also terminated if the wick is no longer self-priming or the vapor temperature drop exceeds a specified value (see Section C.1.2.2).

C.1.2.2 Wick Properties

The heat transport capability of any of the five wick geometries shown in Figure C.1-1 can be determined using HPAD. Both homogeneous and composite modes of operation can be evaluated for the first three geometries. The circumferential distribution of the liquid is neglected for the central slab and artery designs. The heat transport capability is determined using the equations developed in the preceding section. Since these equations are general, equivalent wick properties must be derived for the specific wick designs and operational modes. In particular, equivalent properties must be determined for the following:

- K = Permeability - This is either input as a material property; or, in the case of the arterial, annular, and groove geometries, it is calculated consistent with the appropriate friction factor and the hydraulic diameter of the liquid ($D_{h,l}$).

$$K = \frac{D_{h,l}^2}{2f Re}$$

C.1-18

$D_{h,l}$ = Liquid hydraulic diameter - This parameter is defined as:

$$D_{h,l} = \frac{4 A_1}{P_w}$$

C.1-19

$D_{h,v}$ = Vapor hydraulic diameter - This is defined analogous to $D_{h,l}$.

r_p = Effective pumping radius - This is input as a property of the wick material or calculated from the wick geometry.

H_{req} = Static elevation head that must be supported in one "g" environment if the wick is to be self-priming. This is calculated based on wick geometry.

$r_{p,sp}$ = Pumping Radius for self-priming.

The equivalent wick properties are listed in Table C.1-1 for the various wick geometries.

C.1.2.3 Weight Analysis

A weight analysis subroutine which can be employed at the user's option is included in this program. The weight analysis is based on containment of the internal pressure of the working fluid at a specified maximum temperature. The internal pressure is input as the saturated vapor pressure when the maximum temperature is less than the critical temperature. For temperatures exceeding the critical temperature of the working fluid, the internal pressure is calculated from either the Ideal Gas Law or the Beattie-Bridgman Equation depending on which is indicated in the input.

For an Ideal Gas:

$$p = \frac{m R_g T_{max}}{V_t}$$

C.1-20

Wick Type	A_w	A_v	$P_{w,l}$	$P_{w,v}$	K	r_p	H_{req}	$r_p \cdot \theta P$
Central Slab	$\pi R^2 - A_v$	$2R^2 \left(\frac{\pi \phi}{180} \right) - 2bc$	—	$4 \left[C + R \left(\frac{\pi \phi}{180} \right) \right]$	Material Property	Material Property	$2R + h_e$	$2H \cos \theta / H_{req}$
Arterial (Open)	$\pi D_o^2 / 4$	$\pi R^2 - A_w$	πD_o	$\pi (2R + D_o)$	$D_o^2 / 32$	$D_o / 2$	$h_e + h_p + D_o$	$1/4 \left[\sqrt{(h_e + h_p)^2 + 16 H \cos \theta} - (h_e + h_p) \right]$
Arterial (Closed)						Material Property		
Circumferential	$\pi (R_i^2 - R_v^2)$	πR_v^2	—	$2\pi R_v$	Material Property	$R_i - R_v$	$2R + h_e$	$2H \cos \theta / H_{req}$
Annular	$\pi R^2 - A_v$		$2\gamma (R_i + R_v)$		$A_w^2 / 3P_{w,l}^2$			
Axial Grooves	$* \pi R_i^2 - A_v - U N_g$		$2 \left[\delta + 0.325 \left(\frac{2\pi R_i}{N_g} - t_L \right) \right] N_g$		$(4A_w / P_{w,l})^2 / 32$			

$$* U = t_L \delta + \left(0.5 - \frac{\pi}{\theta} \right) w^2 + \left[0.3 \left(\frac{2\pi R_i}{N_g} - t_L \right) \right]^2$$

Table C.1-1: Equivalent Wick Parameters

where "m" is the total fluid inventory required at the operating temperature, and " V_t " is the total internal void volume.

$$m = m_l + m_v \quad \text{C.1-21}$$

with

$$m_l = \rho_l V_l = \rho_l \epsilon' A_w L \quad \text{C.1-22}$$

$$m_v = \rho_v V_v = \rho_v A_v L \quad \text{C.1-23}$$

When the Beattie-Bridgman Equation is used:

$$p = \frac{R_g T_{\max} (1 - \epsilon')}{v^2} (v + B) - \frac{A}{v^2} \quad \text{C.1-24}$$

where "v" is the specific volume

$$v = \frac{V_t}{m} \quad \text{C.1-25}$$

and

$$A = A_o \left(1 - \frac{a}{v}\right) \quad \text{C.1-26}$$

$$B = B_o \left(1 - \frac{b}{v}\right) \quad \text{C.1-27}$$

$$\epsilon' = \frac{c}{v T_{\max}^3} \quad \text{C.1-28}$$

A_o , a , B_o , b , and c are constants for the particular working fluid, which must be input when the Beattie-Bridgman Equation is required. These constants must be input consistent with the following dimensions: pressure in atmospheres, volume in liters/gm mole, temperature in degrees K, and $R = 0.08206$ atm-liters/gm-mole- $^{\circ}$ K. These are the units generally found in the literature.

The weight analysis is performed for a single tube wall thickness which is the larger of the specified wall thickness or the minimum wall thickness required to contain the pressure with a specified safety factor (S). The weight analysis can also be performed parametrically as a function of the radius of a spherical storage volume. This volume would be attached to the heat pipe to reduce containment pressures and subsequently the system weight. The spherical volume shown in Figure C.1-3 is used strictly for containment purposes and should not be confused with the storage reservoir used in gas-controlled heat pipes. A spherical volume is used to simplify the analysis; and, although it is impractical because of its fabricability, this model does give a good indication of the size of a cylindrical reservoir required to minimize the system weight. The wall thicknesses required to contain the pressure are determined from:

$$t = \frac{p R S}{\sigma_y} \quad \text{C.1-29}$$

and

$$\delta = \frac{p R_{st} S}{2 \sigma_y} \quad \text{C.1-30}$$

The total internal volume of the system is:

$$V_t = V_l + V_v + V_{st} + V_w \quad \text{C.1-31}$$

$$V_t = (\pi R^2 - (1 - \epsilon') A_w) L + \frac{4}{3} \pi R_{st}^3 \quad \text{C.1-32}$$

The total weight of the system is calculated as:

$$m_t = m + m_w + m_{hp} + m_{st} \quad \text{C.1-23}$$

where

$$m_w = (\rho A)_w L \quad \text{C.1-34}$$

$$m_{hp} = \pi (t^2 + 2 R t) \rho_{hp} L \quad \text{C.1-35}$$

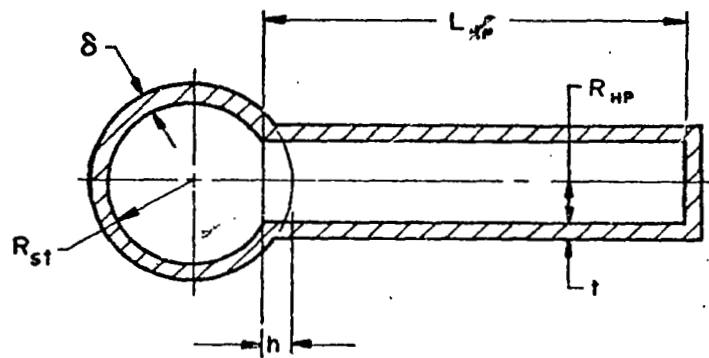

Figure C.1-3. Heat Pipes with Spherical Pressure Containment Vessel

$$m_{st} = \left[\frac{4}{3} \pi (R_{st} + \delta)^3 - \frac{4}{3} \pi R_{st}^3 - 2 \pi R_{st} h \delta \right] \rho_{hp} \quad C.1-36$$

with

$$h = R_{st} - (R_{st}^2 - R^2)^{1/2} \quad C.1-37$$

The weight analysis is performed for the case of no storage volume by setting R_{st} equal to zero (0). Otherwise, the analysis is performed for increasing values of storage radius. The analysis is terminated when either the thickness of the tube wall or the spherical shell becomes less than a specified minimum value, or the radius of the storage volume exceeds a specified maximum. The minimum thicknesses should be specified consistent with fabrication constraints; whereas, the maximum storage radius relates to system integration considerations. When no storage volume is employed, if the tube thickness required for containment is less than the specified minimum, the tube weight is calculated for the specified value.

Also calculated in this subroutine are the temperature drops associated with conduction across the heat pipe wall at the evaporator and condenser sections. These temperature drops are a function of wall thickness and are therefore affected by the size of the storage volume. The equations for these temperature drops are presented in the next section.

C.1.2.4 Heat Transfer Analysis

The heat transfer analysis is based on the thermal model shown in Figure C.1-4. The total thermal impedance R_{th} is composed of a series of individual resistances.

$$R_{th} = R_{w,e} + R_e + R_v + R_{w,c} + R_c \quad C.1-38$$

where the individual resistances are calculated from:

$$R_w = \frac{D_{ext} \ln \left(\frac{D_{ext}}{D_{int}} \right)}{2 K_w A_{ext}} \quad C.1-39$$

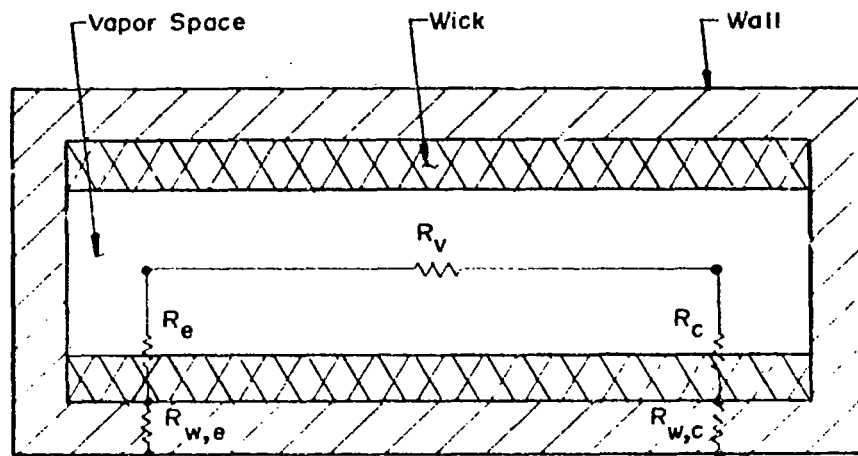

Figure C.1-4. Thermal Impedance Model for Heat Transfer Analysis

$$R_e = \frac{1}{h_e A_{int,e}} \quad C.1-40$$

$$R_v = \frac{P_v T}{\lambda \rho_v \dot{Q}_t} \quad C.1-41$$

$$R_c = \frac{1}{h_c A_{int,c}} \quad C.1-42$$

The internal areas used in the above equations are the actual heat transfer areas associated with the particular wick geometry. Heat transfer coefficients for the slab, arterial, and grooved wicks are input for the evaporator and condenser sections. For the case of the annular or circumferential wicks, the film coefficients are calculated from:

$$h_{an} = \frac{k_l}{(R_i - R_v)} \quad C.1-43$$

$$h_{cir} = \frac{k_{eff}}{(R_i - R_v)} \quad C.1-44$$

where the conductivities are specified input values. Individual temperature drops are calculated from:

$$\Delta T_i = R_i \dot{Q} \quad C.1-45$$

and the overall temperature drop is calculated as:

$$\Delta T = R_{th} \dot{Q} \quad C.1-46$$

As mentioned previously, the heat transport analysis will be terminated if the vapor temperature drop ΔT_v exceeds a specified maximum value.

C.1.2.5 Analysis Summary

The features of this analysis and the basic assumptions employed can be summarized as follows:

C.1.2.5.1 Features

1. The heat transport capability ($\dot{Q}L_{\text{eff}}$) or maximum heat transport (\dot{Q}_{max}) can be calculated for five basic wick geometries.
2. The vapor flow may be laminar or turbulent.
3. The heat transport capability is determined for both one "g" and zero "g" environments.
4. The effect of elevation on heat transport is determined.
5. Both composite and homogeneous modes of operation can be analyzed for the slab, circumferential, and arterial wick geometries.
6. The maximum heat transport is calculated as a function of wick thickness (or liquid flow area). For the axial groove geometry, the number of grooves, their width, and the corresponding land thickness is determined so that the maximum heat transport is realized for a particular aspect ratio. In this case, the maximum heat transport is calculated as a function of groove aspect ratio.
7. The minimum vapor area allowed without incurring the sonic vapor limit is calculated.
8. The effective pumping radius required for self-priming is calculated.
- *9. The fluid inventory, evaporator and condenser film temperature

*When the axial groove geometry is analyzed, the parameters of (i) and the weight of (j) are calculated for those aspect ratios whose calculated heat transport exceeds the specified requirement.

drops and the vapor temperature drop are calculated for the minimum wick thickness necessary to meet a specified heat transport requirement.

- *10. An optional weight analysis can be performed for the minimum wick thickness which satisfies the specified heat transport requirement. This analysis calculates the total system weight consistent with containment of the working fluid at a specified maximum temperature. A spherical storage volume may be employed for containment at the user's option.
11. The working fluid can be treated as a saturated vapor, a real gas, or an ideal gas (whichever is appropriate) at the maximum temperature.
12. The heat transport analysis is terminated at either the sonic vapor limit or when the vapor temperature drop exceeds a specified value.

C.1.2.5.2 Assumptions

1. One-dimensional axial fluid flow, i.e., radial and/or circumferential pressure losses, are negligible.
2. Heat pipe cross-section is circular and uniform over the length of the heat pipe.
3. Wick cross-section is uniform over the length of the heat pipe.
4. Fluid and material properties are constant over the length of the heat pipe.
5. Uniform heat addition and removal.
6. Axial heat conduction in the tube wall is negligible.

*When the axial groove geometry is analyzed, the parameters of (i) and the weight of (j) are calculated for those aspect ratios whose calculated heat transport exceeds the specified requirement.

7. Vapor pressure drop due to gravity is negligible.
8. Momentum losses in the vapor are negligible.
9. Liquid flow is always laminar.
10. Nucleate boiling and entrainment limits are not considered.

These assumptions are consistent with most heat pipe analyses and are generally not prohibitive. The last three assumptions become invalid when very high heat loads or operation with a fluid at a low vapor pressure are required. These conditions are generally encountered with liquid metals at operating temperatures substantially below their boiling point, and care should be exercised when using this analysis under those circumstances.

C.1.3.0 Program Description

C.1.3.1 General

A listing of the program is presented in Appendix A. The program was written in FORTRAN V and was designed to operate on the UNIVAC 1108 system. The FORTRAN names and the physical quantities they represent are listed in Appendix B. Storage requirements are on the order of 50,000 words (octal).

The program logic is illustrated in the flow diagram contained in Appendix C. Basically, the program reads the input data, calculates equivalent wick properties, performs a heat transport and thermal analysis as a function of wick thickness, performs a weight analysis if required, and outputs the data.

The deck setup as shown in Figure C.1-5 consists of job control cards, the program source deck (which may include a fluid property data acquisition code), additional control cards followed by the input data and program termination cards.

As indicated above, the program has two major options. First, a fluid property data acquisition code can be utilized in conjunction with the HIPAD source program. This eliminates the need for inputting the various fluid properties at the specified vapor temperature as part of the data deck. The second option is the weight analysis. Either option is exercised by using the appropriate integer in the fourth

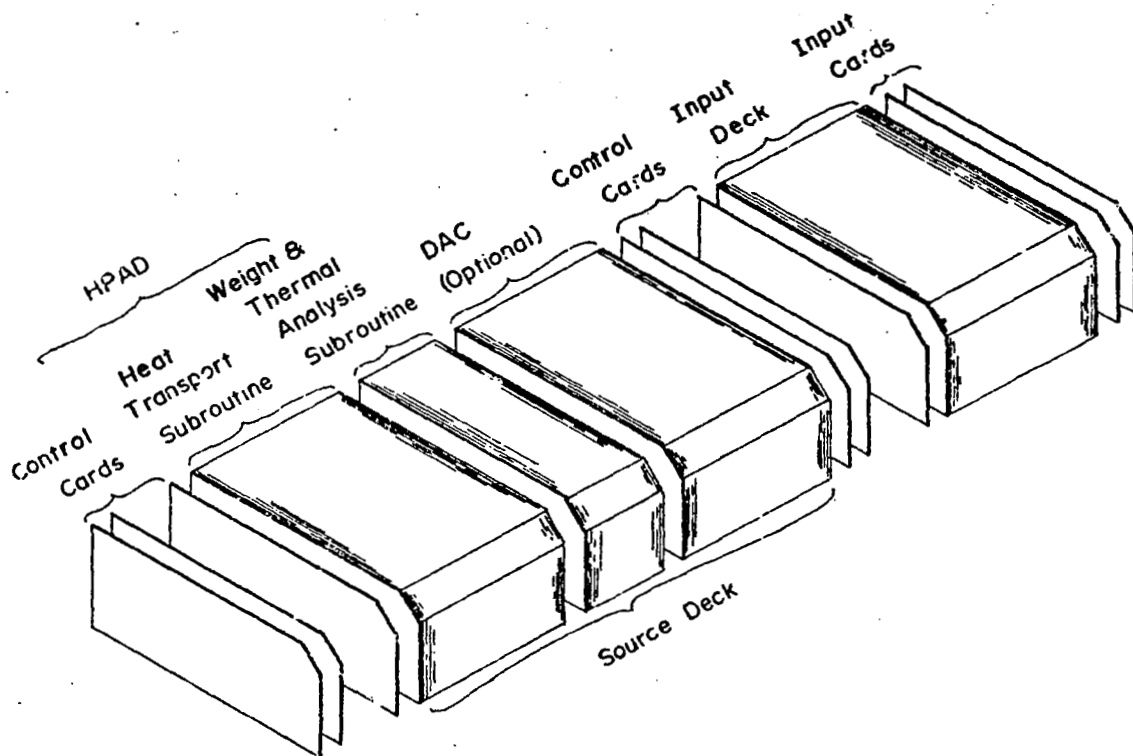

Figure C.1-5. Program Deck Setup

input card of the data deck as described in the next section.

C.1.3.2 Input Description

Table C.1-2 describes the entries to be made on the various input cards and indicates when each of the optional cards are to be excluded. The FORTRAN name, format, and units to be used are indicated for each entry. A listing of sample input data for a homogeneous circumferential wick and for the axial groove wick is presented in Table C.1-3 and C.1-4.

C.1.3.3 Output Description

The program outputs essentially all input data. This is followed by the heat transport analysis. The self-priming requirement and the minimum allowable vapor area (based on not exceeding the sonic limit) are printed. A table in which the film and vapor temperature drops and the calculated heat transport performance parameters are listed as a function of wick thickness or groove aspect ratio is printed next. This table is followed by a summary of the parameters associated with the minimum wick thickness or aspect ratio's which satisfy a specified heat transport requirement. If the requirement cannot be satisfied by the particular design, the following statement will appear at the end of the preceding table: "No Area Exists to Satisfy QMAX Requirement". If a weight analysis is requested, the tube thickness required for containment and a weight breakdown are listed in tabular form as a function of the wick storage volume radius for the minimum thickness or those aspect ratios which satisfy the heat transport requirement. This is then followed by a table which lists the conduction temperature drops and the system's temperature drop as a function of the storage volume radius. A listing of typical output data is presented in Appendix D with the sample problem.

C.1.3.4 Nomenclature

The nomenclature used in the Heat Pipe Analysis and Design Code section is given in the following tabulation.

Table C.1-2 Input Data Description

<u>Input Card No.</u>	<u>Format</u>	<u>Fortran Name</u>	<u>Description</u>	<u>Unit</u>
1	2A6	HD1 HD2	Headings (working fluid)	-
2	5A6	HD3 HD4 HD5 HD12	Headings (heat pipe material)	-
3	10A6	HD6 HD7 HD8 HD9 HD10 HD11 HD13 HD14 HD15 HD16	Headings (type of wick)	-
4	6I3	MORE	Control Point, integer < 1 for last set of data, otherwise integer > 1	-
		OPWT	Control Point, integer < 1 without weight analysis, otherwise integer > 1	-
		DATA	Control Point, integer > 1 no data acquisition code, otherwise integer < 1	-
		OTOW	Control Point, type of wick geometry 1 slab 2 arterial 3 annular 4 circumferential 5 axial grooves	-
		STATE	Control Point, integer > 1 use Beattie-Bridgman Equation, integer < 1 use Ideal Gas Law	-
		FLUID	Control Point, type of working fluid (DAC)	-

<u>Input Card No.</u>	<u>Format</u>	<u>Fortran Name</u>	<u>Description</u>	<u>Unit</u>
5	3F10.5	TEMP	Operating temperature	$^{\circ}\text{K}$
		TMAX	Maximum system temperature	$^{\circ}\text{K}$
		DT	Maximum allowable vapor temperature drop	$^{\circ}\text{K}$
6	6E10.4	RHOL	Liquid density	kg/m^3
		RHOV	Vapor density	kg/m^3
		XLAMD	Latent heat of vaporization	w-s/kg
		SIGMA	Surface tension	N/m
		XMUL	Dynamic liquid viscosity	$\text{kg}/\text{m}\cdot\text{s}$
		XMUV	Dynamic vapor viscosity	$\text{kg}/\text{m}\cdot\text{s}$
7	2F10.5	XMW	Molecular weight of working fluid	kg/mole
		GAMMA	Ratio of the specific heats	
8*	5E10.4	ASO SA BSO SB SC	Constants for Beattie-Bridgman Equation (pressure in atmosphere, volume in liter/ gm-mole, temperature in $^{\circ}\text{K}$, $R=0.28206$ atm liters/gm-mole $^{\circ}\text{K}$)	
9	E10.4	PHI	Wetting angle	degrees
10	6F10.5	QMAX	Maximum heat transport	W
		PERF	Performance factor	-
		FSAFE	Safety factor	-
		HIGH	Elevation between the condenser end and evaporator end	m

* Card 8 is needed only when the value of card 4 (5) is an integer smaller than 1 and the value of card 4 (2) is an integer greater than 1.

<u>Input Card No.</u>	<u>Format</u>	<u>Fortran Name</u>	<u>Description</u>	<u>Unit</u>
		SIGN	Sign convention , +1 positive elevation -1 negative elevation	-
		VCID	Void fraction of the wick material	-
11	3F10.5	XLEV	Length of the evaporator section	m
		XLAD	Length of the adiabatic section	m
		XLCO	Length of the condenser section	m
12	4E10.4	XOD	Outside diameter of the heat pipe	m
		TMN	Minimum wall thickness of the heat pipe	m
		DELM	Minimum wall thickness of the storage reservoir	m
		RMAX	Maximum allowable radius of the storage reservoir	m
13	3E10.4	RHOM	Density of the heat pipe material	kg/m ³
		STRES	Yield stress for the heat pipe material	N/m ²
		WALLK	Thermal conductivity of the wall material	W/m ⁰ K
14*	2I3	I 1	Mesh size of the coarse wick material	-
		I 2	Mesh size of the fine wick material	-
15	5E10.4	XKP	Permeability	m ²
		RPE	Effective pumping radius for heat transport	m
		CRPE	Effective pore radius for self-priming	m
		HESL	Evaporator film coefficient of slab wick heat pipe	W/m ²⁻⁰ K
		HCSL	Condenser film coefficient of slab wick heat pipe	W/m ²⁻⁰ K

* Card 14 to Card 15 are needed only if the value of Card 4 (4) is equal to one.

<u>Input Card No.</u>	<u>Format</u>	<u>Fortran Name</u>	<u>Description</u>	<u>Unit</u>
16	4E10.4	D 1	Diameter of the coarse wick material	m
		D 2	Diameter of the fine wick material	m
		RHOW1	Density of the coarse wick material	kg/m ³
		RHOW2	Density of the fine wick material	kg/m ³
17*	I3	CTAR	Control Card 1 for closed artery 2 for open artery	
18**	5E10.4	XMCWD	Minimum wick thickness (i.e., diameter of the artery)	m
		STINC	Step increment for wick thickness	m
		H	Pedestal height of arterial wick	m
		HEAR	Evaporator film coefficient of arterial wick	W/m ² -°K
		HCAR	Condenser film coefficient of arterial wick	W/m ² -°K
		19***	6E10.4	XMCWD
		STINC	Step increment for wick thickness	m
		RPE	Effective pumping radius for heat transport	m
		H	Pedestal height of arterial wick	m
		HEAR	Evaporation film coefficient of arterial wick	W/m ² -°K
		HCAR	Condenser film coefficient of arterial wick	W/m ² -°K

* Cards 17 to Card 19 are needed only if the value of Card 4 (4) is equal to two (2).

** Card 18 is not needed if the value of Card 17 is equal to 1.

*** Card 19 is not needed if the value of Card 17 is equal to two (2).

<u>Input Card No.</u>	<u>Format</u>	<u>Fortran Name</u>	<u>Description</u>	<u>Unit</u>
20	2E10.4	D 1	Diameter of the wire of the screen mesh	m
		RHOW1	Density of the wick material	kg/m ³
21*	3E10.4	XMCWD	Minimum wick thickness (i. e., distance between the wick and the tube wall)	m
		STINC	Step increment for wick thickness	m
		XKLIQ	Thermal conductivity of the working fluid	W/m-°K
22*	2E10.4	D 1	Diameter of the wire of the screen mesh	m
		RHOW1	Density of the wick material	kg/m ³
23**	3E10.4	RPE	Effective pumping radius for heat transport	m
		XKP	Permeability	m ²
		XKEFF	Effective thermal conductivity of the liquid and wick in circumferential wick heat pipe	W/m-°K
24**	2E10.4	D 1	Diameter of the wire of the screen mesh	m
		RHOW1	Density of the wick material	kg/m ³
25***	8E10.4	ARMAX	Maximum value of aspect ratio of the groove	m
		ARMIN	Minimum value of aspect ratio of the groove	m
		WMAX	Maximum value of the groove width	m
		WMIN	Minimum value of the groove width	m
		TLMAX	Maximum value of the land thickness of the groove	m
		TLMIN	Minimum value of the land thickness of the groove	m

* Card 21 and 22 are needed only if the value of Card 4 (4) is equal to three (3).

** Cards 23 and 24 are needed only if the value of Card 4 (4) is equal to four (4)

*** Cards 25 and 26 are not needed if the value of Card 4 (4) is equal to five (5).

<u>Input Card No.</u>	<u>Format</u>	<u>Fortran Name</u>	<u>Description</u>	<u>Unit</u>
		HEGR	Evaporator film coefficient of the grooved heat pipe	$W/m^2-^{\circ}K$
		HCGR	Condenser film coefficient of the grooved heat pipe	$W/m^2-^{\circ}K$
26***	2I3	NDAR	Number of groove aspect ratio	-
		NDWD	Number of groove widths	-

*** Cards 25 and 26 are not needed if the value of Card 4 (4) is equal to five (5).

NITROGEN
 ALUMINUM ALLOY 6061-T6
 HOMOGENEOUS WICK AGAINST THE WALL (200 MESH SCREEN)

2	2	2	4	1	2			
80.		300.		10.0				
0.0000E+00								
5.0		1.0		2.0		.00254	1.0	0.7
0.2		0.8		0.2				
1.2700E-02	8.9000E-04	8.9000E-04	8.9000E-04	5.8000E-02				
2.7000E+03	2.7500E+08	1.6000E+02						
7.7000E-11	6.8500E-05	1.4000E-01						
5.3300E-05	2.2500E+03							

Table C.1-3. Sample Input Data for a Homogeneous Circumferential Wick

C.1-29

NITROGEN
ALUMINUM ALLOY 6061-T6
AXIAL RECTANGULAR GROOVED HEAT PIPE
0 2 0 5 1 2
80. 300. 10.0
8.0000E+025.9000E+001.9500E+058.2000E-031.4480E-045.8400E-06
28.0 1.4
0.0000E+00
0.005 1.0 2.0 .00254 1.0 0.7
0.2 0.5 0.2
1.2700E-028.9000E-048.9000E-045.0800E-02
2.7000E+032.7600E+081.6000E+02
1.5000E+005.0000E-017.6200E-044.0600E-045.1000E-043.8100E-043.8000E+027.6000E+02
3 3

Table C.1-4 Sample Input Data for a Axial Groove Wick

NOMENCLATURE

<u>Symbol</u>	<u>Description</u>
A	Area
A, A ₀ , B, B ₀	Constants for Beattie-Bridgman Equation
D	Tube diameter
D _h	Hydraulic diameter
F _l	Pressure drop ratio
H	Wicking height factor
K	Permeability
L	Length
N	Transport factor
P	Pressure
P _w	Wetted perimeter
Q	Axial heat flow rate
R	Radius, thermal resistance
Re	Reynolds number
R _g	Gas constant
S	Safety factor
T	Temperature
V	Volume
a, b, c	Constants for Beattie-Bridgman Equation
f	Friction factor
g	Acceleration
h	Heat transfer coefficient, elevation
k	Thermal conductivity
m	Mass
r _p	Pumping radius
t	Thickness
w	Groove width
α	Groove half angle
β	Heat pipe orientation with respect to gravity
γ	Ratio of specific heats
δ	Groove depth, thickness of wall of storage volume
ε	Porosity
η	Gravity factor
θ	Contact angle
λ	Heat of vaporization
μ	Dynamic viscosity
ν	Kinematic viscosity
ρ	Density
σ	Surface tension

Subscripts

Symbol

Description

a	Adiabatic
an	Annular wick
c	Condenser
cir	Circumferential wick
e	Evaporator
eff	Effective
ext	External
hp	Heat pipe
i	Index, individual
int	Internal
l	Liquid
max	Maximum
min	Minimum
req	Required
sp	Self-priming
st	Storage volume
t	Total
v	Vapor
W	Wick
w	Wall

Appendix A. Flow Diagram of
Heat Pipe Analysis and Design Code

PRECEDING PAGE BLANK NOT FILMED

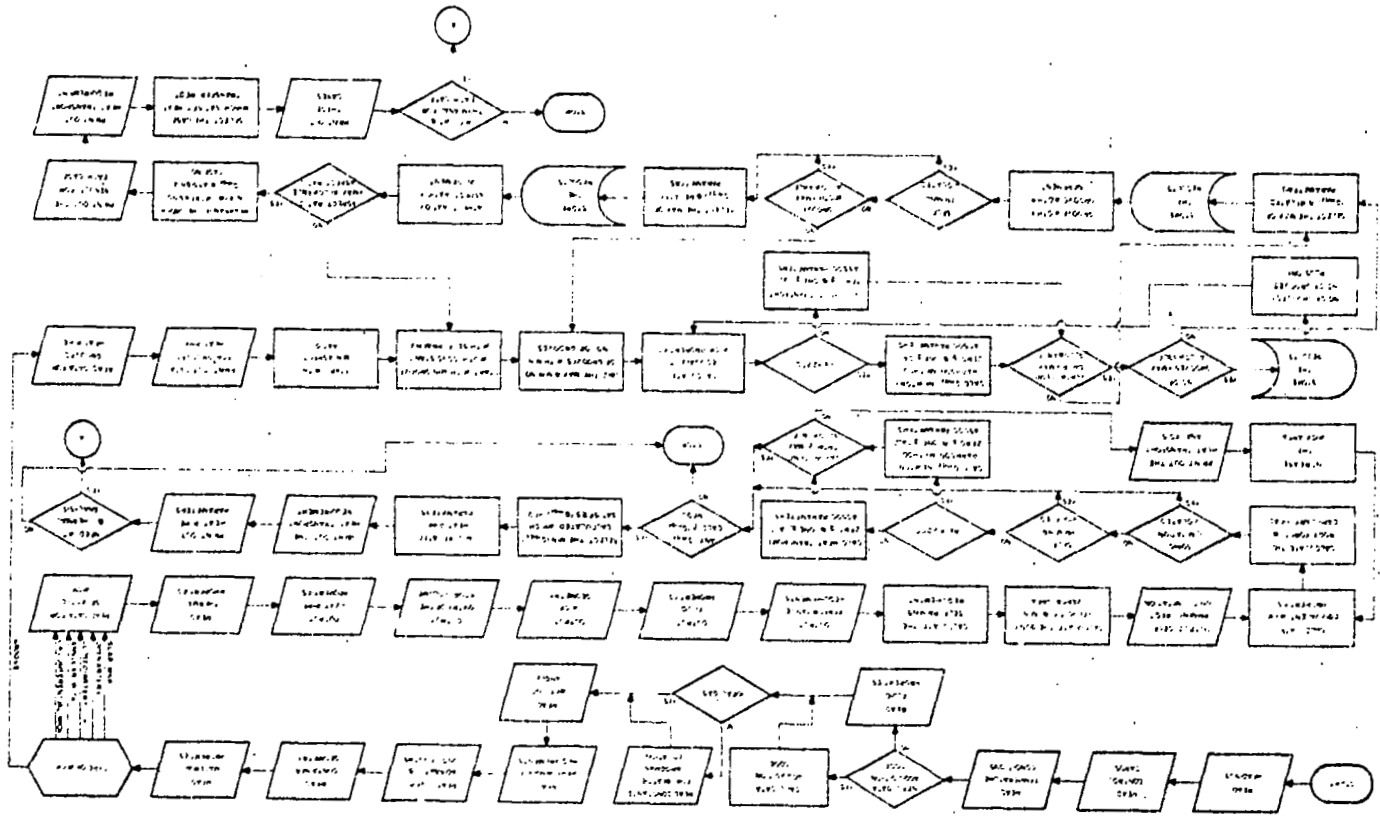

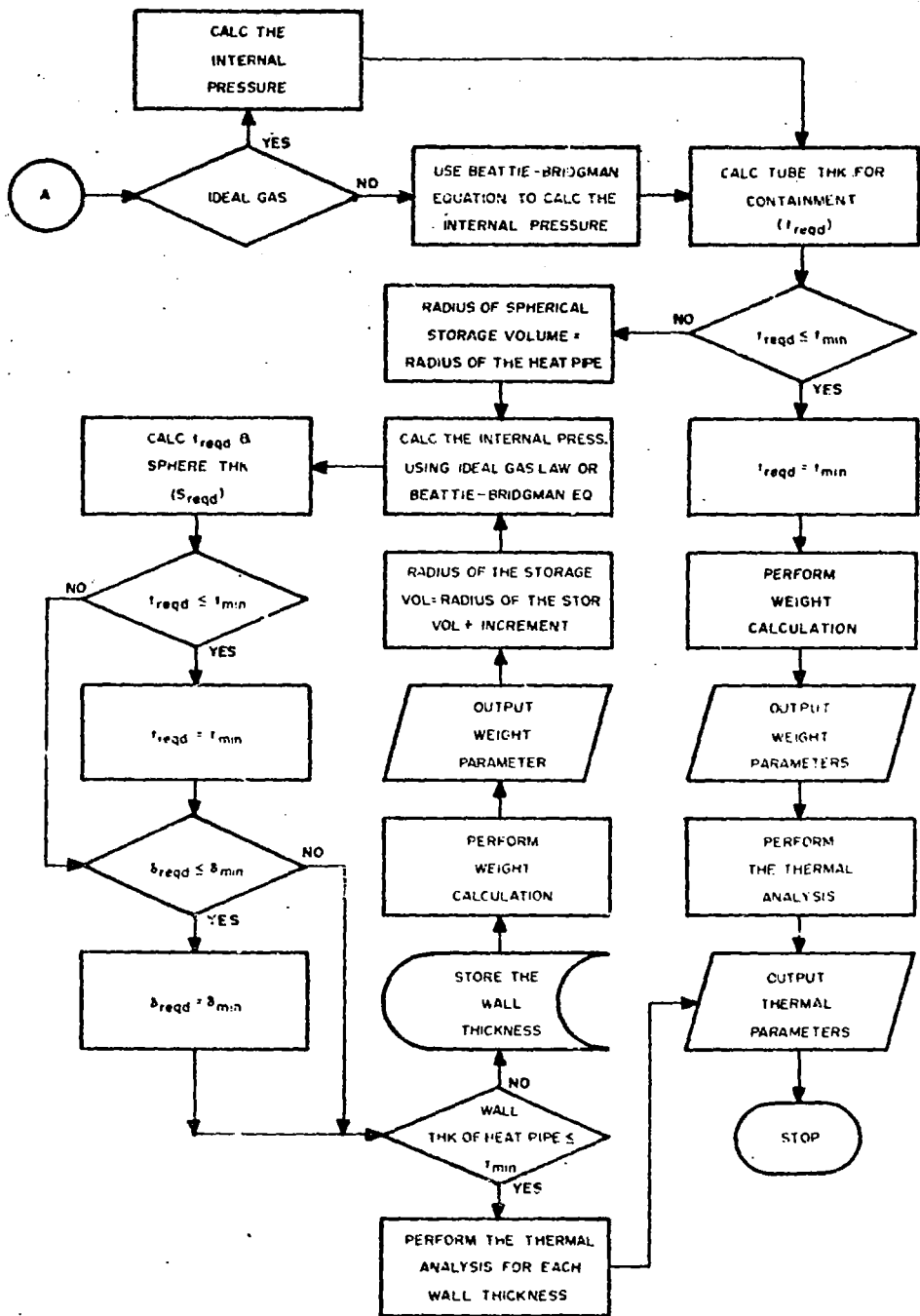

Appendix B. FORTRAN Names

PRECEDING PAGE BLANK NOT FILMED

<u>Fortran Name</u>	<u>Description</u>	<u>Units</u>
HD1, HD2	Headings (working fluid)	
HD3, HD4,	Headings (heat pipe material)	
HD5, HD12		
HD6, HD7,	Headings (type of wick)	
HD8, HD9,		
HD10, HD11,		
HD13, HD14,		
HD15, HD16		
MORE	Control Point, integer = 0 for last set of data, otherwise interger = 2	
OPWT	Control Point, integer < 1 without weight analysis, otherwise integer > 1	
DATA	Control Point, integer < 1 no data acquisition code, otherwise integer > 1	
CTOW	Control Point, type of wick geometry 1 slab 2 arterial 3 annular 4 circumferential 5 axial grooves	
STATE	Control Point, integer > 1 use Beattie-Bridgman Equation, integer < 1 use Ideal Gas Law	
FLUID	Control Point, type of working fluid 1 hydrogen 2 nitrogen 3 oxygen 4 water 5 ammonia 6 methanol 7 acetone 8 freon-21 9 sodium 10 potassium 11 lithium 12 mercury	
TEMP	Operating temperature	$^{\circ}\text{K}$
TMAX	Maximum system temperature	$^{\circ}\text{K}$
DT	Maximum allowable vapor temperature drop	$^{\circ}\text{K}$
RHOL	Liquid density	kg/m^3
RHOV	Vapor density	kg/m^3
XLAMD	Latent heat of vaporization	$\text{W s}/\text{kg}$
SIGMA	Surface tension	N/m
XMUL	Dynamic liquid viscosity	$\text{kg}/\text{m s}$
XMUV	Dynamic vapor viscosity	$\text{kg}/\text{m s}$

<u>Fortran</u> <u>Name</u>	<u>Description</u>	<u>Units</u>
XMW	Molecular weight of the working fluid	kg/mole
GAMMA	Ratio of the specific heats	
ASO	Constant for Beattie-Bridgman Equation	
SA		
BSO		
SB		
SC		
PHI	Wetting angle	degrees
PIH	Wetting angle	radians
QMAX	Maximum heat transport	W
PERF	Performance factor	
FSAFE	Safety factor	
HIGH	Elevation between the condenser end and evaporator end	m
SIGN	Sign convention, +1 positive elevation, -1 negative elevation	
VOID	Void fraction of the wick material	
XLEV	Length of the evaporator section	m
XLAD	Length of the adiabatic section	m
XLCO	Length of the condenser section	m
XOD	Outside diameter of the heat pipe	m
TMIN	Minimum wall thickness of the heat pipe	m
DELM	Minimum wall thickness of the storage reservoir	m
RMAX	Maximum allowable radius of the storage reservoir	m
RHOM	Density of the heat pipe material	kg/m ³
STRES	Yield stress for the heat pipe material	N/m ²
WALLK	Thermal conductivity of the wall material	W/m ⁰ K
II	Indicator	
IND	Counter for performance parameters	
QTRAN	Maximum heat transport requirement	W
XLHP	Length of the heat pipe	m
XLEFF	Effective heat pipe length	m
QPRED	Maximum heat transport requirement (including the performance factor)	W
XID	Inside diameter of the heat pipe	m
AE	Internal area of the evaporator	m ²
AC	Internal area of the condenser	m ²
RHEAD	Required head of self-priming for slab wick, circumferential wick, and annular wick	m
XNL	Liquid transport factor	W/m ²
I1	Mesh size of the coarse wick material	
I2	Mesh size of the fine wick material	
XKP	Permeability	m ²
RPE	Effective pumping radius for heat transport	m

<u>Fortran</u> <u>Name</u>	<u>Description</u>	<u>Units</u>
CRPE	Effective pore radius for self-priming	m
HESL	Evaporator film coefficient of slab wick heat pipe	W/m ² °K
HCSL	Condenser film coefficient of slab wick heat pipe	W/m ² °K
D1 & D2	Diameter of the wires of the screen mesh	m
RHOW1	Density of the coarse wick material	kg/m ³
RHOW2	Density of the fine wick material	kg/m ³
XMCWD	Minimum wick thickness	m
CWL	Wick thickness	m
CPCOR	Capillary pumping pressure for self-priming	N/m ²
CCORE	Self-priming head	m
CPGHD	Capillary pumping pressure for heat transport	N/m ²
BODY	Body force	N/m ²
OTAR	Control card (1) for closed artery (2) for open artery	-
STINC	Step increment for wick thickness	m
H	Pedestal height of arterial wick	m
HEAR	Evaporator film coefficient of arterial wick	W/m ² °K
HCAR	Condenser film coefficient of arterial wick	W/m ² °K
DMAX	Maximum allowable diameter of artery for self-priming	m
XKLIQ	Thermal conductivity of the working fluid	W/m °K
XKEFF	Effective thermal conductivity of the liquid and wick in circumferential wick heat pipe	W/m °K
SONIC	Sonic velocity at operating temperature	m/s
ASONIC	Minimum allowable vapor area for sonic limit	m ²
NL	Indicator	-
EHEAD	Equivalent pore radius for self-priming	m
B	Half of the wick thickness	m
THETA	Angle	rad ians
C	Chord length	m
AV	Vapor area	m ²
CHEAD	Net capillary pressure for heat transport	N/m ²
AW	Wick area	m ²
WP	Wetted perimeter of liquid area	m
DHV	Hydraulic diameter of the vapor	m
ARC	Arc length	m
HAE	Evaporator film conductance	W/K
HAC	Condenser film conductance	W/K
DHL	Hydraulic diameter of the liquid	m
QLMAX	Maximum heat transport factor in "1-g" environment	W m
QLMOG	Maximum heat transport factor in "0-g" environment	W m

<u>Fortran</u> <u>Name</u>	<u>Description</u>	<u>Units</u>
REYND	Reynolds number	-
DIFT	Vapor temperature drop	°K
QMAXC	Maximum heat transport in "1-g" environment	W
QMAOG	Maximum heat transport in "0-g" environment	W
DQDH	Slope of heat transport versus evaporator elevation	W/m
AETD	Evaporator temperature drop	°K
ACTD	Condenser temperature drop	°K
XQ(IND)	Temporary storage space for QMAXC	W
XA(IND)	Temporary storage space for AV	m ²
XB(IND)	Temporary storage space for CWD	m
XL(IND)	Temporary storage space for AW	m ²
XQL(IND)	Temporary storage space for QLMAX	W/m
XARC(IND)	Temporary storage space for ARC	m
XDIFT(IND)	Temporary storage space for DIFT	K
AREA	Vapor area	m ²
AREAL	Liquid area	m ²
VTD	Vapor temperature drop	°K
LAYER	Number of layers of screen mesh	-
XMFLD	Mass of the working fluid	kg
VOW	Actual volume of the wick	m ³
WTW	Weight of the wick	kg
ETD	Evaporator temperature drop	°K
CTD	Condenser temperature drop	°K
C1 } C2 } C3 }	Constants for turbulent vapor flow	-
CHECK	Counter for iterations when vapor is turbulent	-
QT(I)	Temporary storage space for Q _{max}	W
A(N)	Constant for turbulence calculation	N/m ²
DA(N)	Derivative of turbulent transport equation	-
QTEMP(II)	Temporary storage space for Q _{max}	W
ARMAX	Maximum value of aspect ratio	-
ARMIN	Minimum value of aspect ratio	-
WMAX	Maximum value of the groove width	m
WMIN	Minimum value of the groove width	m
TLMAX	Maximum value of the land thickness	m
TLMIN	Minimum value of the land thickness	m
HEGR	Evaporator film coefficient of the grooved heat pipe	W/m ² °K
HCGR	Condenser film coefficient of the grooved heat pipe	W/m ² °K
NDAR	Number of groove aspect ratios	-
NDWD	Number of groove widths	-
DNAR	Number of groove aspect ratios	-
ARINC	Increment for the aspect ratio	-
DAR(I)	Aspect ratios	-
DAWSP(I)	Maximum allowable width of the groove at an aspect ratio for self-priming	m

<u>Fortran</u> <u>Name</u>	<u>Description</u>	<u>Units</u>
DREQ	Required pumping height	m
DNWD	Number of groove widths	-
WINC	Increment for the groove width	m
PA	Groove width	m
XYZ(J)	Groove width	m
DEP(J)	Groove depth	m
SRV	Internal radius of the grooves	m
NMAX	Maximum number of grooves	-
NMIN	Minimum number of grooves	-
XK	Number of grooves	-
DXL(K)	Land thickness of the groove	m
BASE	Base thickness of the groove	m
SAV	Vapor area	m ²
SAI	Vapor area	m ²
AGO	Area of one groove	m ²
AMO	Meniscus area of one groove	m ²
ALO	Liquid area of one groove	m ²
GVOWI(K)	Total liquid area	m ²
ALAND	Total land area	m ²
DD1(K)	Maximum heat transport factor for groove geometry in "1-g" environment	W m
EE1(K)	Maximum heat transport for groove geometry in "1-g" environment	W
FF1(K)	Maximum heat transport factor for groove geometry in "0-g" environment	W m
GG1(K)	Maximum heat transport in "0-g" environment	W
HH1(K)	Slope of heat transport versus evaporator elevation in "1-g" environment	W m
DGM(K)	Mass of the working fluid	kg
DWICK(K)	Weight of the land of the groove	kg
NG1(K)	Number of grooves	-
NG2(J)	Number of grooves	-
BB2(J)	Groove width	m
CC2(J)	Land thickness	m
DD2(J)	Maximum heat transport factor for groove geometry in "1-g" environment	W m
EE2(J)	Maximum heat transport for groove geometry in "1-g" environment	W
FF2(J)	Maximum heat transport factor for groove geometry in "0-g" environment	W m
GG2(J)	Maximum heat transport for groove geometry in "0-g" environment	W
HH2(J)	Slope of heat transport versus evaporator elevation in "1-g" environment	W m
PP2(J)	Mass of the working fluid	kg

<u>Fortran Name</u>	<u>Description</u>	<u>Units</u>
QQ2(J)	Weight of the land of the groove	kg
RR2(J)	Vapor temperature drop	$^{\circ}\text{K}$
GVOW2(J)	Total liquid area	m^2
DXL(I)	Land thickness	m
NG(I)	Number of grooves	-
DG1(I)	Maximum heat transport factor for groove geometry in "1-g" environment	W m
DG2(I)	Maximum heat transport for groove geometry in "1-g" environment	W
DG3(I)	Maximum heat transport factor for groove geometry in "0-g" environment	W m
DG4(I)	Maximum heat transport for groove geometry in "0-g" environment	W
DG5(I)	Slope of heat transport versus evaporator elevation in "1-g" environment	W m
DVTD(I)	Vapor temperature drop	$^{\circ}\text{K}$
GVOW3(I)	Total liquid area	m^2
NSTOR	Temporary storage space	-
STOR1 to 13	Temporary storage space	-
NCAAE	Case number	-
STHIK(I)	Wall thickness of the storage reservoir	m
THICK(I)	Wall thickness of the heat pipe	m
CONST	Gas constant	$\frac{\text{atm l}}{\text{gmole}^{\circ}\text{K}}$
BAW	Wick area	ft^2
RS	Internal radius of storage reservoir	m
WTS	Weight of storage reservoir	kg
DELR	Required wall thickness of storage reservoir	m
BDELM	Minimum wall thickness of storage reservoir	m
BRHOM	Density of the heat pipe material	lb/ft^3
BRHOL	Density of the working fluid	lb/ft^3
BR	Internal radius of the heat pipe	ft
BXID	Internal diameter of the heat pipe	m
BXLHP	Length of the heat pipe	m
BRMAX	Maximum allowable radius of storage reservoir	ft
BXOL	Outside diameter of the heat pipe	ft
BTEMP	Maximum system temperature	$^{\circ}\text{K}$
BTMIN	Minimum wall thickness	ft
BXMFL	Mass of the working fluid	kg
SPVOL	Specific volume	l/g
A } B }	Coefficients of Beattie, Bridgman Equation	-
EPSI		
PRES	Internal pressure of the system	atm or N/m^2
BPRES	Internal pressure of the system	psi or lb/ft^2

<u>Fortran Name</u>	<u>Description</u>	<u>Units</u>
BTRED	Calculated wall thickness of the heat pipe	ft
TRED	Calculated wall thickness of the storage reservoir	m
BVHP	Volume of the heat pipe	ft ³
WTL	Weight of the working fluid	kg
WTH	Weight of the heat pipe	kg
WT	Total weight	kg
BINCR	Increment for the radius of the storage reservoir	ft
BVST	Volume of the storage reservoir	ft ³
BVTT	Total volume of the system	ft ³
DEXT	Outside diameter of the heat pipe	m
DINT	Inside diameter of the heat pipe	m
AEXTE	External area of evaporator	m ²
AEXTC	External area of condenser	m ²
EWTD	Temperature drop across the evaporator wall	°K
CWTD	Temperature drop across the condenser wall	°K
TTD	Total temperature drop of the system	°K

Appendix C. Program Listing

C1-46

DIMENSION XG(200),XAT(200),XRI(200),XL(200) ,XQL(200),QT(3)
 DIMENSION A(1),DA(3),UTEMP(5),ADTFT(200),XARC(200)
 DIMENSION DAR(200),DAWSP(200),DRFC(200),XYZ(200),DEP(200),DXL(200)
 DIMENSION ODI(200),EE1(200),FF1(200),GG1(200),HH1(200),DGM(200)
 DIMENSION DGW(200),DWICK(200),NG1(200),NG2(200),BB2(200),CC2(200)
 DIMENSION DD7(200),EE2(200),FF2(200),GG2(200),HH2(200),PP2(200)
 DIMENSION QQ(200),NG(200),DG1(200),GG2(200),GG3(200),GG4(200)
 DIMENSION DG5(200),NCASE(200),DVID(200),RR2(200)
 DIMENSION GVW1(200),GVW2(200),GVW3(200)
 INTEGER OPMT,DTOW,GTAR,DATA,STATE,FLUID
 5005 FORMAT (10A6)
 498 FORMAT (16I3)
 5010 FORMAT (8F10.5)
 5009 FORMAT (8E10.4)
 61 FORMAT (//// 24H INPUT DATA (, 10A6,1H))
 63 FORMAT (//19H TUBE MATERIAL ,5A6)
 65 FORMAT (//2E20.7,10X,F4.2)
 70 FORMAT (//4E20.7)
 174 FORMAT (//2X,10A6)
 607 FORMAT (//E20.7,15X,E20.7,24X,E20.7)
 609 FORMAT (//23H WIRE DIAMETER OF THE ,13,39H MESH SCREEN WIRE
 DIAMETER OF THE ,13,15H MESH SCREEN(M))
 610 FORMAT (//E20.7,21X,E20.7)
 611 FORMAT (//17H DENSITY OF THE ,13,40H MESH SCREEN(KG/M-M-M) DENS
 ITY OF THE ,13,22H MESH SCREEN(KG/M-M-M))
 78 FORMAT (//18H WORKING FLUID = ,2A6 ,4H AT ,F9.2,3H(K))
 622 FORMAT (//4X,F6.1)
 623 FORMAT (//4X,F8.3)
 691 FORMAT (//4X,F10.2)
 86 FORMAT (////76H SELF-PRIMING REQUIREMENT
 1 (IN IG WITH ELEVATION OF,E20.7,4H(M))
 634 FORMAT (//E20.7,20X,E20.7,13X,E20.7)
 637 FORMAT (//E20.7,59X,E20.7)
 202 FORMAT (//E20.7,10X,E20.7:
 50 FORMAT (////51H HEAT TRANSPORT ANALYSIS (,
 1,10A6,1H))
 10 FORMAT (°1°)
 60 FORMAT (////° HEAT PIPE ANALYSIS AND
 I D E S I G N (HPAD)°)
 62 FORMAT (////° HEAT PIPE PROPERTIES°)
 720 FORMAT (///° THERMAL CONDUCTIVITY(W/M-K)°)
 64 FORMAT (///° YIELD STRESS(W-M) DENSITY(KG/M-M-M) CONTAIN
 1&R SAFETY FACTOR°)
 66 FORMAT (///° OUTSIDE DIAMETER(M) MIN. WALL THICKNESS(M)°)
 68 FORMAT (///° LENGTH OF THE HEAT PIPE SECTIONS°)
 69 FORMAT (///° EVAPIN) AD(M) COND
 1(M) TOTAL(M)°)
 400 FORMAT (////° G E O M E T R Y O F T H E S T O R A G E
 I V O L U M E °)
 71 FORMAT (///° RADIUS(M) OF MAX. STORAGE VOLUME°)
 73 FORMAT (////° W I C K G E O M E T R Y °)
 605 FORMAT (///° Y I D F R A C T I O N O F T H E W I C K °)
 606 FORMAT (///° P E R M E A B I L I T Y (M) E F F . P U M P I N G R A D . F O R H E A
 T T R A N S P O R T (M) E F F . P U M P I N G R A D . F O R S E L F - P R I M I N G (M) °)
 608 FORMAT (///° M I N . T H I C K N E S S O F T H E W I C K (M) °)
 614 FORMAT (///° M I N . D I A M E T E R O F T H E A R T E R Y (M) °)
 615 FORMAT (///° W I R E D I A M E T E R O F T H E S C R E E N (M) °)
 617 FORMAT (///° D E N S I T Y O F T H E S C R E E N W I R E (K G / M - M - M) °)

618 FORMAT (///° F F F . P U M P I N G R A D . F O R H E A T T R A N S P O R T (M) °)
 619 FORMAT (///° M I N . D I S T A N C E B E T W E E N T H E W A L L A N D T H E W I C K (M) °)
 620 FORMAT (///° P E R M E A B I L I T Y (M) E F F . P U M P I N G R A D . F O R H E A T T R A
 N S P O R T A N D S E L F - P R I M I N G (M) °)
 77 FORMAT (///° F L U I D P R O P E R T I E S °)
 621 FORMAT (///° M O L E C U L A R W E I G H T (K G / M O L E) °)
 4022 FORMAT (///° T H E R A T I O O F S P E C I F I C H E A T S (C P / C V) °)
 728 FORMAT (///° T H E R M A L C O N D U C T I V I T Y (W / M - K) °)
 730 FORMAT (///° E F F E C T I V E T H E R M A L C O N D U C T I V I T Y O F T H E L I Q U I D A N D T H E
 W I C K (W / M - K) °)
 624 FORMAT (///° C O N T A C T A N G L E (D E G) °)
 79 FORMAT (///° S U R F A C E T E N S I O N (N / M) L A T E N T H E A T (J / K G) °)
 81 FORMAT (///° L I Q . D E N S I T Y (K G / M - M) V A P O R D E N S I T Y (K G / M - M) °)
 83 FORMAT (///° L I Q . V I S C O S I T Y (K G / M - S) V A P O R V I S C O S I T Y (K G / M - S) °)
 184 FORMAT (///° L I Q U I D T R A N S P O R T F A C T O R (W / M - M) °)
 888 FORMAT (////° P E R F O R M A N C E R E Q U I R E M E N T S °)
 889 FORMAT (///° E L E V A T I O N (M) °)
 4202 FORMAT (///° P E D E S T A L H E I G H T (M) °)
 890 FORMAT (///° M A X . T E M P E R A T U R E (K) °)
 143 FORMAT (///° M A X . A L L O W A B L E V A P O R T E M P E R A T U R E D R O P (K) °)
 85 FORMAT (////° O U T P U T D A T A °)
 633 FORMAT (///° M A X . C A P I L L A R Y H E A D F O R S E L F - P R I M I N G (M) R E Q U I R E D
 1 H E A D (M) E Q U I V A L E N T E F F . R A D . F O R S E L F - P R I M I N G (M) °)
 635 FORMAT (///° M A X . A L L O W A B L E D I A M E T E R O F T H E A R T E R Y F O R S E L F - P R I M I N
 G (M) °)
 636 FORMAT (///° M A X . A L L O W A B L E D I S T A N C E B E T W E E N T H E W A L L A N D T H E W I C K
 1 F O R R E Q U I R E D H E A D (M) R E Q U I R E D H E A D (M) °)
 200 FORMAT (///° S O N I C L I M I T A T I O N °)
 201 FORMAT (///° S O N I C V E L O C I T Y (M / S) M I N I M U M V A P O R A R E A (M - M)
 1) F O R S O N I C L I M I T A T I O N °)
 4630 FORMAT (///° T H I C K N E S S O F V A P O R T E M P E V A P O R A T O R C O N
 1 D E N S E R (G=1) (G=1) (G=0) (G=0)
 2 (G=1)°)
 4631 FORMAT (///° D I A M E T E R O F V A P O R T E M P E V A P O R A T O R C O N
 1 D E N S E R (G=1) (G=1) (G=0) (G=0)
 2 (G=1)°)
 4632 FORMAT (///° D I S T A N C E B E T W E E N T H E V A P O R T E M P E V A P O R A T O R C O N
 1 D E N S E R (G=1) (G=1) (G=0) (G=0)
 2 (G=1)°)
 4633 FORMAT (///° W A L L A N D T H E W I C K D R O P T E M P D R O P T E M
 1 P D R O P (QLEFF)MAX QMAX (QLEFF)MAX QMAX
 2 (DQ/DH)°)
 11 FORMAT (///° (M) (M) (K) (K) (M)
 1 (K) (W-M) (M) (W) (W-M) (K) (M)
 2 (W/M)°)
 3630 FORMAT (///° T H E W I C K D R O P T E M P D R O P T E M
 1 P D R O P (QLEFF)MAX QMAX (QLEFF)MAX QMAX
 2 (DQ/DH)°)
 23 FORMAT (///° N O A R E A E X I T S T O S A T I S F Y X M A X (M) R E Q U I R E M E N T °)
 31 FORMAT (///° Q M A X (M) R E Q U I R E M E N T (I N C L U D I N G T H E P E R F O R M A N C E F A C T O R
 1) I S °)
 126 FORMAT (///° T H E P E R F O R M A N C E F A C T O R I S °)
 26 FORMAT (///° T H E M A X . V A P O R A R E A (M - M) T O S A T I S F Y Q M A X (M) R E Q U I R E M E
 N T I S °)
 424 FORMAT (///° T H E M I N . T H I C K N E S S (M) O F T H E W I C K T O S A T I S F Y Q M A X (M)
 1 R E Q U I R E M E N T I S °)
 425 FORMAT (///° T H E M I N . D I A M E T E R (M) O F T H E W I C K T O S A T I S F Y Q M A X (M) R
 1 R E Q U I R E M E N T I S °)

CI-47

```

428 FORMAT (/// THE MAX. DISTANCE (M) BETWEEN THE WALL AND THE WICK TO
1 SATISFY QMAX (W) REQUIREMENT IS*)
801 FORMAT (/E16.3,3X,E14.3)
132 FORMAT (/7X,F4.2)
555 FORMAT (/E20.7,1H,13,12H LAYER(S) OF 13,14H-13,14H MESH SCREEN(S) )
770 FORMAT (/E20.7,9X,E20.7,9X,E20.7)
804 FORMAT (/E16.3,3X,3E14.3,3X,4H4.A.,2X,F16.3,3X,4H4.A.,2X,F14.3,9X,
14H4.A.)
722 FORMAT (/5X,F20.7,16X,E20.7)
74 FORMAT (/F20.2,24X,E20.7)
99 FORMAT (/4X,13,5X,13,7X,F6.2,7X,E10.3,5X,E10.3,2X,F10.3,4X,E10.3,4
1X,E10.3,4X,E10.3,5X,F10.3)
91 FORMAT (/// THE MIN. LIQUID AREA (M-M) TO SATISFY QMAX (W) REQUIR (M)
MENT IS*)
93 FORMAT (/// MASS OF THE WORKING FLUID REQUIRED (G)*)
145 FORMAT (/// VAPOR TEMPERATURE DROPIX) EVAPORATOR TEMP. DROPIX)
1 CONDENSER TEMP. DROPIX)*)
151 FORMAT (/// FLOW IS NOW TURBULENT (REYNOLD NO. GREATER THAN 2
1200).*)
203 FORMAT (/// MINIMUM WICK AREA VIOLATES THE SONIC LIMITATION, NO
1 HEAT TRANSPORT AND WEIGHT ANALYSES ARE PRESENTED *)
13 FORMAT (/// THE MAX. AND MIN. VALUES OF ASPECT RATIO OF THE GROOVE
1 (GROOVE DEPTH/GROOVE WIDTH)*)
14 FORMAT (/// THE MAX. AND MIN. VALUES OF THE GROOVE WIDTH (M)*)
15 FORMAT (/// THE MAX. AND MIN. VALUES OF THE LAMO THICKNESS (M)*)
721 FORMAT (/// EVAPORATOR FILM COEFFICIENT (W/M-K) CONDENSER F
1 ILM COEFFICIENT (W/M-K)*)
16 FORMAT (/// THE ASPECT RATIOS OF THE GROOVE MAX. ALLOWABLE G
1 (GROOVE WIDTH FOR SELF-PRIMING) *)
17 FORMAT (/ (GROOVE DEPTH/GROOVE WIDTH)*)
35 FORMAT (///
1 (G=1) (G=1) (G=0) (G=0)
2 (G=1)*)
36 FORMAT (/ CASE GROOVE ASPECT RATIO GROOVE LAND
1 (LEFF)MAX QMAX (LEFF)MAX QMAX
2 (CM)*)
37 FORMAT (/ NO. NO. (DEPTH/WIDTH) WIDTH (M) THICKNES
1 (M) (M-M) (M) (M) (M)
2 (M)*)
54 FORMAT (/// THE CASES WHICH SATISFY THE QMAX (W) REQUIREMENT ARE L
1 IST AS FOLLOWING*)
55 FORMAT (/
1 (G=1)*)
56 FORMAT (/ CASE GROOVE ASPECT RATIO GROOVE LAND
1 QMAX MASS OF THE VAPOR TEMP. EVAPORATOR CONDENS
2 ER*)
57 FORMAT (/ NO. NO. (DEPTH/WIDTH) WIDTH (M) THICKNESS
1 (M) (M) FLUID (G) DROPIX) TEMP DROPIX) TEMP D
2 ROP (K)*)
771 FORMAT (/// EVAPORATOR TEMP. DROPIX) CONDENSER TEMP. DROPIX)*)
59 FORMAT (/4X,13,5X,13,7X,F6.2,3X,F14.3)
500 READ (5,5005) HD1,HD2
CDDM=0
WHITC=16.10)
READ (5,5005) MG3,MD4,MCS,MG12
READ (5,5005) HGG,MG7,MGG,MD5,MD1G,MG11,MD13,MD14,MD15,MD16
READ (5,498) MRE,DPNT,DATA,STUM,STATE,FLUID
READ (5,5010) TFP,TPAR,OT

```

```

IF (DATA.GT.1) GO TO 5011
READ (5,5009) RMOL,RHOL,RLAND,SIGMA,XMUL,XMUV
READ (5,5010) XMH,GAMMA
GO TO 5023
5011 LSUPP=2
CALL DAC (FLUID,LSUPP,LDUT,RHOL,RHUV,RLAND,SIGMA,XMUL,XMUV,TEMP,P
1 V,XMH,GAMMA)
IF (LOUT.GT.1) GO TO 1
5023 IF (STATE.EQ.1) GO TO 5022
READ (5,5009) ASD,SA,BSO,SB,SC
5022 READ (5,5009) PHI
PHI=PHI*3.14159/180.0
PIH=PHI*180.0/3.14159
READ (5,5010) QMAX,PERF,PSAFE,HIGH,SIGN,VOID
READ (5,5010) XLEV,XLAD,XLCD
READ (5,5009) XOD,MIN,DELF,RMAX
READ (5,5009) RHOM,STRES,HALLK
II=1
IND=0
QTRAN=QMAX
XLMP=XLEV+XLAD+XLCD
XLEFF=XLAD+XLEV/2.0+XLCD/2.0
QPRD=QMAX*PRF
Q=QPRD
XID=XOD-2.0*MIN
AF=XID*3.14159*XLEV
AC=XID*3.14159*XLCD
RHEAD=XID*SIGN*HIGH
KVL=SIGMA*RLAND*RMOL/XMUL
R=XID/2.0
MS=HIGH*SIGN
GO TO (330,331,332,333,12),OTDM
330 READ (5,498) II,12
READ (5,5009) CRP,RPE,CRPE,MESL,MCSL
READ (5,5009) D1,D2,RHDW1,RHDW2
IF (II.EQ.12) GO TO 9000
XMCWD=2.0*(D1+2.0*D2)
GO TO 9002
9000 XMCWD=2.0*D1
9002 CWD=XMCWD
CPCOR=2.0*SIGN*COS(PHI)/CRPE
CCOR=CPCOR/(RMOL*9.8)
CPGHO=2.0*SIGN*COS(PHI)/RPE
BODY=RMOL*9.8*(XID+SIGN*HIGH)
CHEAD=CPGHO*BODY
GO TO 334
331 READ (5,498) OTAR
GO TO (1332,1331),STAR
1331 READ (5,5009) XMCWD,STINC,H,HEAR,HCAR
GO TO 1333
1332 READ (5,5009) XMCWD,STINC,RPE,H,HEAR,HCAR
1333 READ (5,5009) D1,RHDW1
CWD=XMCWD
AMH=SIGN*HIGH
CMAXA=(AMH*H*16.0*SIGN*COS(PHI)/(RMOL*9.8))*(9.8-H)/2.0
CCOR=CMAXA*H
GO TO 334
332 READ (5,5009) XMCWD,STINC,FFLIQ

```

CI-48

```
HEAD(5,500?) D1,RHOW1
CMD=XMCWD
UMAX=2.0*SIGMA*COSE(PHI)/(RMUL*9.8*(XID*HIGH*SIGN))
CCURE=UMAX
RHEAD=XID*HIGH*SIGN
GO TO 334
333 READ(5,500?) XKP,RPE,XKEFF
READ(5,500?) D1,RHOW1
XMCWD=2.0*U1
CMD=XMCWD
CPGMD=2.0*SIGMA*COSE(PHI)/RPE
BODY=RMUL*9.8*(XID*SIGN*HIGH)
CMCAD=CPGMD*BODY
CCDKE=CPGMD/(RMUL*9.8)
RHEAD=XID*HIGH*SIGN
D2=0.0
334 SONIC=((GAMMA*TEMP*1.01545.33*32.2/XMW)**0.5)*0.3048
ASONIC=PERF*GMAX*(2.0*(GAMMA*1.01)**0.5/(XLAND*RHUV*SONIC))
NL=1
WRITE (6,10)
WRITE (6,60)
WRITE (6,61) HD6,HD7,HD8,HD9,HD10,HD11,HD13,HD14,HD15,HD16
WRITE (6,62)
WRITE (6,63) MD3,MD4,MD5,MC12
WRITE (6,720)
WRITE (6,70) WALLK
WRITE (6,64)
WRITE (6,65) STRES,RHOM,FSAFE
WRITE (6,66)
WRITE (6,70) XGD,TRIN
WRITE (6,68)
WRITE (6,69)
WRITE (6,70) XLEV,XLAD,XLCO,XLHP
WRITE (6,400)
WRITE (6,71)
WRITE (6,70) RMAX
WRITE (6,10)
WRITE (6,73)
WRITE (6,174) HD6,HD7,HD8,HD9,MD10,MC11,MD13,MD14,MD15,MD16
WRITE (6,605)
WRITE (6,623) VOID
GO TO (601,602,603,604),OTOW
601 WRITE (6,606)
WRITE (6,607) XKP,RPE,CRPE
WRITE (6,508)
WRITE (6,70) XMCWD
WRITE (6,609) I1,I2
WRITE (6,610) D1,D2
WRITE (6,611) I1,I2
WRITE (6,610) RMCW1,RMCW2
GO TO 705
602 GO TO (613,612),OTAR
612 WRITE (6,614)
WRITE (6,70) XMCWD
WRITE (6,615)
WRITE (6,70) D1
WRITE (6,617)
WRITE (6,70) RMCW1
```

```
GO TO 705
613 WRITE (6,618)
WRITE (6,70) RPE
WRITE (6,614)
WRITE (6,70) XMCWD
WRITE (6,615)
WRITE (6,70) D1
WRITE (6,617)
WRITE (6,70) RMCW1
GO TO 705
603 WRITE (6,619)
WRITE (6,70) XMCWD
WRITE (6,615)
WRITE (6,70) D1
WRITE (6,617)
WRITE (6,70) RMCW1
GO TO 705
604 WRITE (6,620)
WRITE (6,607) XKP,RPE
WRITE (6,615)
WRITE (6,70) D1
WRITE (6,617)
WRITE (6,70) RMCW1
705 WRITE (6,10)
WRITE (6,77)
WRITE (6,78) HD1,HD2,TEMP
WRITE (6,621)
WRITE (6,622) XMW
WRITE (6,622)
WRITE (6,623) GAMMA
GO TO (723,327,725,725),OTOW
723 WRITE (6,721)
WRITE (6,722) HESL,HCSL
GO TO 727
327 WRITE (6,721)
WRITE (6,722) HEAR,HGAR
GO TO 727
725 WRITE (6,720)
WRITE (6,70) XKLIO
GO TO 727
726 WRITE (6,730)
WRITE (6,70) XKEFF
727 WRITE (6,624)
WRITE (6,623) PIH
WRITE (6,79)
WRITE (6,70) SIGMA,XLAMP
WRITE (6,81)
WRITE (6,70) RHOL,RHOV
WRITE (6,83)
WRITE (6,70) KMJL,KMUV
WRITE (6,184)
WRITE (6,70) RNL
WRITE (6,10)
WRITE (6,888)
WRITE (6,31)
WRITE (6,70) GPRED
WRITE (6,126)
WRITE (6,132) PERF
```

C.I-49

```
WRITE (6,889)
WRITE (6,701) MS
GO TO (4200,4201,4200,4200),CLOW
4201 WRITE (6,4202)
WRITE (6,701) M
4200 WRITE (6,890)
WRITE (6,891) TMAX
WRITE (6,1431)
WRITE (6,891) DT
701 WRITE (6,101)
WRITE (6,851)
WRITE (6,861) MS
GO TO (630,631,632,630),OTOW
630 WRITE (6,633)
EHEAD=2.0*SIGMA/(RHOL*9.8*RHEAD)
WRITE (6,634) CCORE,RHEAD,EHEAD
GO TO 513
631 WRITE (6,635)
WRITE (6,701) OMAX
GO TO 513
632 WRITE (6,636)
WRITE (6,637) CCORE,RHEAD
513 GO TO (305,306,307,308),OTOW
305 B=CWD/2.0
THETA=ACOS(B/R)
C=R*SIN(THETA)
AV=2.0*R*R*THETA-2.0*B*C
GO TO 74
306 AV=3.14159*(XID**2-XMCWD**2)/4.0
GO TO 74
307 AV=3.14159*(XID-2.0*XMCWD)**2/4.0
GO TO 74
308 AV=3.14159*(XID-2.0*XMCWD)**2/4.0
74 WRITE (6,200)
WRITE (6,201)
WRITE (6,202) SONIC,ASONIC
IF (ASONIC.GT.AV) GO TO 3
WRITE (6,50) HD6,HD7,HD8,HD9,HD10,HD11,HD13,HD14,HD15,HD16
GO TO (625,626,627,625),OTOW
625 WRITE (6,4630)
WRITE (6,4630)
GO TO 629
626 WRITE (6,4631)
WRITE (6,4630)
GO TO 629
627 WRITE (6,4632)
WRITE (6,4633)
629 WRITE (6,111)
5 GO TO (320,321,322,323),OTOW
320 B=CWD/2.0
CHEAD=CPGHD-BODY
IND=IND+1
THETA=ACOS(B/R)
C=R*SIN(THETA)
AV=2.0*R*R*THETA-2.0*B*C
AW=3.14159*R*R*AV
WP=4.0*(C**2*THETA)
DHV=4.0*AV/WP
```

```
KV=DHV/2.0
ARC=2.0*THETA/3.14159
HAE=MESL*ARC*AE
HAC=MCSL*ARC*AC
GO TO 324
321 AV=3.14159*(XID**2-CWD**2)/4.0
WP=3.14159*(XID+CWD)
DHV=4.0*AV/WP
KV=DHV/2.0
AW=3.14159*CWD**2/4.0
DHL=CWD
XKP=DHL*DHL/32.0
ARC=1.0
HAE=HEAR*AE
HAC=HCAH*AC
IF (CWD.GT.DMAX) GO TO 762
GO TO (351,352),UTAR
351 CPGHD=2.0*SIGMA*COS(PHI)/RPE
GO TO 353
352 CPGHD=2.0*SIGMA*COS(PHI)/(CWD/2.0)
353 BODY=RHOL*9.8*(AH+CWD)
CHEAD=CPGHD-BODY
IND=IND+1
GO TO 324
322 AV=3.14159*(XID-2.0*CWD)**2/4.0
WP=3.14159*(XID-2.0*CWD)
DHV=4.0*AV/WP
KV=DHV/2.0
DHL=2.0*CWD
XKP=DHL*DHL/48.0
AW=3.14159*XID*XID/4.0-AV
CPGHD=2.0*SIGMA*COS(PHI)/CWD
BODY=RHOL*9.8*(XID*SIGMA*HIGH)
CHEAD=CPGHD-BODY
IND=IND+1
ARC=1.0
HAE=XXLIQ*AE/CWD
HAC=XXLIQ*AC/CWD
IF (CWD.GT.DMAX) GO TO 762
GO TO 324
323 AV=3.14159*(XID-2.0*CWD)**2/4.0
WP=3.14159*(XID-2.0*CWD)
DHV=4.0*AV/WP
KV=DHV/2.0
AW=3.14159*XID*XID/4.0-AV
CHEAD=CPGHD-BODY
IND=IND+1
ARC=1.0
HAE=XXEFF*AE/CWD
HAC=XXEFF*AC/CWD
324 WLMAX=0.5*CH*AD/(XHL/(2.0*RHOL*AW*XKP*XLAND)+4.0*XWUV/(AV*RHOV*XL
[AMD*KV**2.0])
GLMUL=0.5*CPGHC/(XHL/(2.0*RHOL*AW*XKP*XLAND)+4.0*XWUV/(AV*RHOV*XL
[AMD*R*V**2.0])
NIYND=2.0*(GLMAX/XLEFF)*RV/(AV*XWUV*XLAND)
IF (MEYND.GT.2200.0) GO TO 40
DIFF=18.0*XWUV*GLMAX/(AV*RHOV*XLAND*RV**2))*TEMP/(XLA*OORMUV)
WMAX=GLMAX/XLEFF
```

C1-50

```

QMAOG=QLMUG/XLEFF
DODH=-0.5*(9.0+RHOL*SIGN(XLEFF)/(XML/(2.0+RHOL*AM*XP*XLAND)+4.0)
IXMUV/(AV*RHOV*XLAND*V*2.0))
UGDH=DGDH*(QLMAX/ABS(QLMAX))
AETO=QMAX/HAC
ACTO=QMAX/HAC
WRITE (6,801) CWD,DIFT,AETO,ACTO,QLMAX,GMAX,QLMUG,QMAOG,DODH
42 XQ(IND)=QMAX
XA(IND)=AV
XB(IND)=CWD
XL(IND)=AM
XQL(IND)=QLMAX
XARC(IND)=ARC
XDIFT(IND)=DIFT
IF (DIFT.GT.DT) GO TO 1000
GO TO (340,344,344,342),OTOW
340 IF (11.EQ.12) GO TO 9001
STINC=2.0*(D1+D2)
GO TO 344
9001 STINC=2.0*D1
GO TO 344
342 STINC=2.0*D1
344 CWD=CWD+STINC
GO TO (571,572,573,574),OTOW
571 IF (CWD.GT.XID) GO TO 1000
GO TO 318
572 TCWD=CWD+H
IF (TCWD.GT.XID) GO TO 1000
IF (CWD.GT.OMAX) GO TO 1000
GO TO 318
573 TCWD=2.0*CWD
IF (TCWD.GT.XID) GO TO 1000
IF (CWD.GT.OMAX) GO TO 1000
GO TO 318
574 TCWD=2.0*CWD
IF (TCWD.GT.XID) GO TO 1000
318 IF (AV.GE.ASONIC) GO TO >
1000 IMAX=1
IF (IND.EQ.1) GO TO 162
IF (XQ(1).GE.OPRED) GO TO 4
DO 21 J=1,IND
IF (XQ(J).OPRED) 21,22,24
22 IMAX=J
AREA=XA(IMAX)
CWD=XB(IMAX)
AREAL=XL(IMAX)
ARC=XARC(IMAX)
VTD=XDIFT(IMAX)
GO TO 25
24 IMAX=J
IM=IMAX-1
AREA=XA(IM)+(XA(IMAX)-XA(IM))*(OPRED-XQ(IM))/(XQ(IMAX)-XQ(IM))
CWD=XB(IM)+(XB(IMAX)-XB(IM))*(OPRED-XQ(IM))/(XQ(IMAX)-XQ(IM))
AREAL=XL(IM)+(XL(IMAX)-XL(IM))*(OPRED-XQ(IM))/(XQ(IMAX)-XQ(IM))
ARC=XARC(IM)+(XARC(IMAX)-XARC(IM))*(OPRED-XQ(IM))/(XQ(IMAX)-XQ(IM))
1)
VTD=XDIFT(IM)+(XDIFT(IMAX)-XDIFT(IM))*(OPRED-XQ(IM))/(XQ(IMAX)-XQ(IM))

```

```

GU TO 25
21 CONTINUE
762 WRITE (6,23)
WRITE (6,31)
WRITE (6,70) OPRED
WRITE (6,143)
WRITE (6,891) DT
GO TO 1
25 WRITE (6,31)
WRITE (6,70) OPRED
WRITE (6,126)
WRITE (6,132) PERF
WRITE (6,26)
WRITE (6,70) AREA
AM=AREAL
GO TO (420,421,427,420),OTOW
420 WRITE (6,424)
LAYER=(CWD-D2)/(2.0*(D1+D2))
XLA=LAYER
WRITE (6,555) CWD,LAYER,I1,I2
XMFLD=RHOL*V(D)*AM*XLHP+RHOV*AREA*XLHP
VOW=(1.0-V(D))*AM*XLHP
GO TO 444
421 WRITE (6,425)
XMFLD=RHOL*(AM*XLHP+2.0*D1*VOID)*XLHP)+AREA*RHOV*XLHP
VOW=0.0
GO TO 423
427 WRITE (6,428)
XMFLD=RHOL*AM*XLHP+RHOV*AREA*XLHP
VOW=0.0
423 WRITE (6,70) CWD
444 WRITE (6,91)
WRITE (6,70) AM
WRITE (6,93)
WRITE (6,70) XMFLD
WRITE (6,143)
WRITE (6,891) DT
GO TO (310,311,312,313),OTOW
310 WTW=AM*XLHP*(D1*RHOW1+D2*RHOW2)/(D1+D2)
HAE=HCCL*ARC*AE
HAC=HCCL*ARC*AC
VOW=(1.0-V(D))*AM*XLHP
GO TO 314
311 WTW=RHOW1*XLHP*(3.14159*CWD+2.0*H)*2.0*D1
HAE=HEAR*AE
HAC=HCAR*AC
GO TO 316
312 WTW=R1*W1*XLHP*3.14159*(XID-2.0*CWD)*2.0*D1
HAE=XKLIQ*AE/CWD
HAC=XKLIQ*AC/CWD
GO TO 314
313 WTW=3.14159*(XID-CWD)*XLA*RHOW1*XLHP*2.0*D1
HAE=XKEFF*AE/CWD
HAC=XKEFF*AC/CWD
314 ETO=QTRAN/HAC
CTD=QTRAN/HAC
WRITE (6,145)
WRITE (6,770) VTD,ETO,CID

```

CJ-51

```

CALL WTANA IDELM,FSAFE,XOD,TMIN,OPWT,RHOL,RHOM,RMAX,XID,XLHP,XM
IFLD,XMM,TMAX,STRES,WTW,NDUM,OTOW,VTD,ETD,CTD,WALLK,QTRAN,XLEV,XLCO
Z,HAC,MAE,STATE,ASO,SA,BSD,SB,SC,VOW,AW)
GO TO 1
40 IF (NL.GT.2) GO TO 48
NL=NL+5
WRITE (6,151)
GO TO 1411,4112,4113,4114) OTOW
4111 WRITE (6,4630)
WRITE (6,3630)
GO TO 4115
4112 WRITE (6,4631)
WRITE (6,3630)
GO TO 4115
4113 WRITE (6,4632)
WRITE (6,4633)
GO TO 4115
4114 WRITE (6,4630)
WRITE (6,3630)
4115 WRITE (6,11)
48 C1=ABS(CHEAD)
C2=XMUL*(XLHP+XLAD)/(2.0*RHOL*AW*XP*X(LAD)
C3=0.0655*XMOV**0.25*(XLEV/3.14*XLAD/1.56*XLCO/3.14)/(RHOM*RV**1.2
15*(XLAND*AV)**1.75)
CHECK=0.0
QT(1)=2.0*C1/(C2+C3)
41 CHECK=CHECK+1.0
IF (CHECK.GT.15.0) GO TO 45
N=1
A(N)=C3*QT(N)**1.75+C2*QT(N)-C1
DA(N)=1.75*C3*QT(N)**0.75+C2
IF (DA(N) .43,44,43)
44 QT(N)=QT(N)+0.02
GO TO 41
43 QT(N+1)=QT(N)-A(N)/DA(N)
QTEMP(1)=QT(N)
IF (ABS((QT(2)-QT(1))/QT(1)).LT.0.01) GO TO 45
QT(N)=QT(N+1)
GO TO 41
45 IF (I.GT.1) GO TO 818
II=II+1
CHEAD=CPGHD
GO TO 40
818 II=II-1
UMAXC=QTEMP(1)
XDIFT(IND)-C3*QTEMP(1)**1.75*TEMP/(XLAND*RHOM)
DIFT=XDIFT(IND)
AETD=QTEMP(1)/MAE
ACTD=QTEMP(1)/HAC
IF (XDIFT(IND).GT.DT) GO TO 1000
WRITE (6,804) CWD,XDIFT(IND),AETD,ACTD,QTEMP(1),QTEMP(2)
GO TO 42
4 AXEA=XA(1)
CWD=XD(1)
ARCAL=XL(1)
YTD=XDIFT(1)
ARC=XARC(1)
QT=AY=XQ(1)

```

```

GO TO 25
3 WRITE (6,203)
GO TO 1
12 READ (5,5009) ARMAX,ARMIN,WMAX,WMIN,TLMAX,TLMIN,HEGR,HCGR
READ (5,498) NDAR,NDWD
WRITE (6,10)
WRITE (6,60)
WRITE (6,61) HD6,HD7,HD8,HD9,HD10,HD11,HD13,HD14,HD15,HD16
WRITE (6,62)
WRITE (6,63) HD3,HD4,HD5,HD12
WRITE (6,64)
WRITE (6,65) STRES,RHOM,FSAFE
WRITE (6,66)
WRITE (6,70) XOD,TMIN
WRITE (6,66)
WRITE (6,69)
WRITE (6,70) XLEV,XLAD,XLCO,XLHP
WRITE (6,400)
WRITE (6,71)
WRITE (6,70) RMAX
WRITE (6,10)
WRITE (6,73)
WRITE (6,174) HD6,HD7,HD8,HD9,HD10,HD11,HD13,HD14,HD15,HD16
WRITE (6,13)
WRITE (6,70) ARMAX,ARMIN
WRITE (6,14)
WRITE (6,70) WMAX,WMIN
WRITE (6,15)
WRITE (6,70) TLMAX,TLMIN
WRITE (6,10)
WRITE (6,77)
WRITE (6,78) HD1,HD2,TEMP
WRITE (6,621)
WRITE (6,622) XMM
WRITE (6,624)
WRITE (6,623) PIH
WRITE (6,4622)
WRITE (6,623) GAMMA
WRITE (6,721)
WRITE (6,722) HEGR,HCGR
WRITE (6,79)
WRITE (6,70) SIGMA,XLAMD
WRITE (6,81)
WRITE (6,70) RHOL,RHOM
WRITE (6,83)
WRITE (6,70) XMUL,XMOV
WRITE (6,184)
WRITE (6,70) XNL
WRITE (6,10)
WRITE (6,888)
WRITE (6,31)
WRITE (6,70) QPRED
WRITE (6,126)
WRITE (6,132) PERF
WRITE (6,889)
WRITE (6,70) HS
WRITE (6,890)
WRITE (6,891) THAX

```

C.I-52

```
WRITE (6,143)
WRITE (6,891) DT
WRITE (6,10)
WRITE (6,85)
WRITE (6,86) HS
WRITE (6,16)
WRITE (6,17)
DNAR=NDAR-1
ARINC=(ARMAX-ARMIN)/DNAR
DAR1=ARMIN-ARINC
DU 3 I=1,NDAR
DAR1=DAR1+ARINC
DAR(I)=DAR1
DAWSP(I)=1-HIGH*SIGN*([HIGH*SIGN]**2+8.0*SIGMA*COS(PHI)*DAR(I)/[RM
IDL*9.8]**0.5)/(2.0*DAR(I))
DREQ(I)=HIGH*SIGN+DAWSP(I)*DAR(I)
WRITE (6,34) DAR(I),DAWSP(I)
33 CONTINUE
WRITE (6,200)
WRITE (6,201)
SONIC=(GAMMA*TEMP*1.8*1545.33*32.2/XMW**0.5)**0.3048
ASONIC=PERF*QMAX*(2.0*(GAMMA+1.0)**0.5/[XLAMD*RHOV*SONIC])
WRITE (6,202) SONIC,ASONIC
WRITE (6,50) MD6,MD7,MD8,MD9,MD10,MD11,MD13,MD14,MD15,MD16
WRITE (6,35)
WRITE (6,36)
WRITE (6,37)
DNWD=NDWD-1
WINC=(WMAX-WMIN)/DNWD
DO 113 I=1,NDAR
PA=WMIN-WINC
DO 114 J=1,NDWD
PA=PA+WINC
XYZ(J)=PA
IF (XYZ(J).GT.DAWSP(I)) GO TO 121
DEP(J)=DAR(I)*XYZ(J)
SRV=(XID-2.0*DEP(J))/2.0
NRAX=2.0*SRV*3.14159/(XYZ(J)+TLMIN)
NRIN=2.0*SRV*3.14159/(XYZ(J)+TLMAX)+1.0
DO 115 K=NRIN,NRAX
IND=K
KK=K
DXL(K)=2.0*SRV*3.14159/KK-XYZ(J)
BASE=3.14159*XID/KK-DXL(K)
SAV=3.14159*SRV*SRV
SAI=3.14159*XID*XID/4.0
AGO=(SAI-SAV-KK*DXL(K)*DEP(J)-KK*(0.3*BASE)**2)/KK
ANO=(0.5-3.14159/8.0)*XYZ(J)**2
ALO=AGO-ANO
AW=ALO*KK
GVCHI(K)=AW
ALAND=SAI-SAV-AGO*KK
WP=2.0*(DEP(J)+0.325*ASE1)*KK
GHL=4.0*AW/WP
AV=SAI-AW-ALAND
IF (AV.LT.ASONIC) GO TO 118
KV=SKV
AKP=(DHL*DHL)/32.0
```

```
APF=XYZ(J)
C*GHU=2.0*SIGMA*CUS(PHI)/RPE
DUOY=RHOL*9.8*(HIGH*SIGN*DEP(J))
CHEAU=CPGHD-DUDY
GO TO 117
3046 C1=AS*(CHEAD)
C2=XMUL*(XLHP+XLAD)/(2.0*RHOL*AW*KKP*XLAND)
C3=0.0655*XMUV**0.25*(XLEV/3.14*XLAD/1.56*XLCD/3.14)/(RHOV*RV**1.2
15*(XLAMD*AV)**1.75)
CHECK=0.0
QT(I)=2.0*CI/(C2+C3)
3041 CHECK=CHECK+1.0
IF (CHECK.GT.20.0) GO TO 3045
N=1
AINI=C3*QT(N)**1.75+C2*QT(N)-C1
DA(N)=1.75*C3*QT(N)**0.75+C2
IF (DA(N)) 3043,3044,3043
3044 QT(N)=QT(N)+0.02
GO TO 3041
3043 QT(N+1)=QT(N)-A(NI)/DA(N)
QTEMP(I)=QT(N)
IF (ABS(QT(2)-QT(1))/QT(1).LT.0.001) GO TO 3045
QT(N)=QT(N+1)
GO TO 3041
3045 IF (I.GT.1) GO TO 3018
II=II+1
CHEAD=CPGHD
GO TO 3048
3018 II=II-1
XDIFT(IND)=C3*QTEMP(II)**1.75*TEMP/(XLAMD*RHOV)
IF (XDIFT(IND).GT.0T) GO TO 118
DDI(K)=0.0
EEI(K)=QTEMP(II)
FFI(K)=0.0
GGI(K)=QTEMP(2)
HHI(K)=0.0
DGM(K)=RHOL*XLHP*AW*RHOV*XLHP*AV
DMICK(K)=RHOL*XLHP*ALAND
NGL(K)=K
GO TO 115
117 ODI(K)=0.5*(CHEAD/(XMUL/(2.0*RHOL*AW*KKP*XLAND))+4.0*XMUV/(AV*RHOV*
XLAND*RV**2.0))
EEI(K)=ODI(K)/XLEFF
FFI(K)=0.5*(CPGHD/(XK*XL/(2.0*RHOL*AW*KKP*XLAND))+4.0*XMUV/(AV*RHOV*
XLAND*RV**2.0))
GGI(K)=FFI(K)/XLEFF
KEYND=2.0*EEI(K)*RV/(AV*XMUV*XLAND)
IF (KEYND.GT.2200.0) GO TO 3048
XDIFT(K)=(8.0*XMUV*DDI(K)/(AV*RHOV*XLAND*RV**2.0)*TEMP/(XLAND*RHOV)
IF (XDIFT(K).GT.0T) GO TO 118
HHI(K)=-0.5*(9.8*RHOL*SIGN/XLEFF)/(XMUL/(2.0*RHOL*AW*KKP*XLAND))+4.
10*XMUV/(AV*RHOV*XLAND*RV**2.0))
HHI(K)=HHI(K)+(ODI(K)/ABS(ODI(K)))
NGL(K)=K
DLM(K)=RHOL*XLHP*AW*RHOV*XLHP*AV
DMICK(K)=RHOL*XLHP*ALAND
GO TO 115
118 NGL(K)=K
```

C.I-53

```
XDIF(K)=0.0
DXL(K)=0.0
DDL(K)=0.0
EE1(K)=0.0
FF1(K)=0.0
GG1(K)=0.0
HH1(K)=0.0
UGM(K)=0.0
DWICK(K)=0.0
115 CONTINUE
LL=NMN
AB=EE1(LL)
DO 119 L=NMN,NMAX
IF (AB-EE1(LL)) 120,119,119
120 LL=L
AB=EE1(LL)
119 CONTINUE
NG2(J)=LL
RB2(J)=XYZ(J)
CC2(J)=DXL(LL)
DD2(J)=DD1(LL)
EE2(J)=EE1(LL)
FF2(J)=FF1(LL)
GG2(J)=GG1(LL)
HH2(J)=HH1(LL)
PP2(J)=DGM(LL)
QQ2(J)=DWICK(LL)
RR2(J)=XDIF(LL)
GVOW2(J)=GVOW1(LL)
GO TO 114
121 NG2(J)=0
BR2(J)=0.0
CC2(J)=0.0
DD2(J)=0.0
EE2(J)=0.0
FF2(J)=0.0
GG2(J)=0.0
HH2(J)=0.0
PP2(J)=0.0
QQ2(J)=0.0
RR2(J)=0.0
GVOW2(J)=0.0
114 CONTINUE
MM=1
BC=EE2(M)
DO 133 M=1,NDWD
IF (BC-EE2(M)) 134,133,133
134 MM=M
BC=EE2(M)
133 CONTINUE
XYZ(I)=BR2(MM)
DGW(I)=XYZ(I)
DXL(I)=CC2(MM)
NS(I)=NG2(MM)
DG1(I)=DD2(MM)
DG2(I)=EE2(MM)
DG3(I)=FF2(MM)
DG4(I)=GG2(MM)
```

```
DG5(I)=HH2(MM)
DGM(I)=PP2(MM)
DWICK(I)=QQ2(MM)
NCASE(I)=1
DVT0(I)=RK2(MM)
GVOW3(I)=GVOW2(MM)
113 CONTINUE
GO 135 IN=1,NDAR
IM=IN
CD=DG2(IM)
DO 137 IMM=IM,NDAR
IF (CD-DG2(IMM)) 138,137,137
138 IM=IMM
CD=DG2(IMM)
137 CONTINUE
NSTOR=NG(IM)
STOR1=DGW(IM)
STOR3=DG1(IM)
STOR4=DG2(IM)
STOR5=DG3(IM)
STOR6=DG4(IM)
STOR7=DG5(IM)
STOR8=DGM(IM)
STOR9=DWICK(IM)
STO10=DAR(IM)
STO11=DXL(IM)
STO12=DVT0(IM)
STO13=GVOW3(IM)
DVT0(IM)=DVT0(IM)
NG(IM)=NG(IM)
DGM(IM)=DGM(IM)
DG1(IM)=DG1(IM)
DG2(IM)=DG2(IM)
DG3(IM)=DG3(IM)
DG4(IM)=DG4(IM)
DG5(IM)=DG5(IM)
DGM(IM)=DGM(IM)
DWICK(IM)=DWICK(IM)
DAR(IM)=DAR(IM)
DXL(IM)=DXL(IM)
GVOW3(IM)=GVOW3(IM)
NG(IM)=NSTOR
DGM(IM)=STOR1
DG1(IM)=STOR3
DG2(IM)=STOR4
DG3(IM)=STOR5
DG4(IM)=STOR6
DG5(IM)=STOR7
DGM(IM)=STOR8
DWICK(IM)=STOR9
DAR(IM)=STO10
DXL(IM)=STO11
DVT0(IM)=STO12
GVOW3(IM)=STO13
135 CONTINUE
DO 98 I=1,NDAR
WRITE (6,99) NCASE(I),NG(I),DAR(I),DGM(I),DXL(I),DG1(I),DG2(I),DG3(I),DG4(I),DG5(I)
```

```

98 CONTINUE
WRITE (6,31)
WRITE (6,70) OPMLD
WRITE (6,126)
WRITE (6,132) PEWF
LCASE=0
DO 141 I=1,NOAR
IF (DG2(I)-LT.OPRED) GO TO 142
LCASE=1
141 CONTINUE
142 IF (LCASE.EQ.0) GO TO 762
WRITE (6,54)
WRITE (6,55)
WRITE (6,56)
WRITE (6,57)
HAE=HEGR*AE
HAC=HCGR*AC
DO 58 I=1,LCASE
ETD=DG2(I)/HAE
CTD=DG2(I)/HAC
WRITE (6,59) NCASE(I),NG(I),DAR(I),DGM(I),DXL(I),OG2(I),DGM(I),DVT
10(I),ETD,CTD
58 CONTINUE
STORE=STRES
DO 95 I=1,LCASE
STRES=STORE
VTD=D/TO(I)
WTW=DMICK(I)
NCAAE=1
XMFLD=DGM(I)
VOW=-GYW3(I)
ETD=DG2(I)/HAE
CTD=DG2(I)/HAC
CALL WTANA (DELM,FSAFE,XOD,TMIN,OPWT,RHOL,RHOM,RMAX,XID,XLHP,XM
1FLD,XMW,IMAX,STRES,WTW,NCAAE,OTD,VTD,ETD,CTD,WALLK,QTRAN,XLEV,XLC
20,HAC,HAE,STATE,ASO,SA,BSO,SB,SC,VOW,AW)
95 CONTINUE
1 IF (MORE.GT.1) GO TO 500
STOP
END

```

C.I-54

```

SUBROUTINE WTANA (DELM,FSAFE,XOD,TMIN,OPWT,RHOL,RHOM,RMAX,XID,XLHP,XM
1,XMFLD,XMW,TEMP,STRES,WTW,NCAAE,OTD,VTD,ETD,CTD,WALLK,QTRAN,XLEV,
2,XLCO,HAC,HAE,STATE,ASO,SA,BSO,SB,SC,VOW,AW)
DIMENSION THICK(20),STHIK(20)
INTEGER OPWT,OTD,STATE
87 FORMAT (11)
88 FORMAT (////) WEIGHT ANALYSIS FOR THE
1 S Y S T E M
36 FORMAT (///) (EQUATION OF STATE FOR REAL GAS (I.E.,BEATTIE-BRIDGMA
14 EQUATION) IS USED TO CALCULATE THE INTERNAL PRESSURE)
37 FORMAT (///) (EQUATION OF STATE FOR IDEAL GAS IS USED TO CALCULATE
1 THE INTERNAL PRESSURE)
4 FORMAT (//25H C A S E N U M B E R,4X,I3)
46 FORMAT (///) SAFETY FACTOR MAXIMUM TEMPERATURE(K)

```

```

45 FORMAT (//F11.2,4X,F15.2)
64 FORMAT (///) LIQUID WT.(KG) WICK WT.(KG)
65 FORMAT (//E15.7,E18.7)
23 FORMAT (///) LIQUID WT.(KG)
74 FORMAT (///) RAD.(STORAGE) TUBE THICKNESS ST. THICKNESS PRESSU
1ME HEAT PIPE WT. STORAGE WT. TOTAL WT.
79 FORMAT (1 (M) (M) (M) (M) (M) (M)
1-M) (KG) (KG) (KG) (KG)
303 FORMAT (//E15.7)
42 FORMAT (///) NO STORAGE VOLUME IS NEEDED
11 FORMAT (////) T H E R M A L A N A L Y S I S F O R T H E
1 S Y S T E M
13 FORMAT (///) INSIDE DIAMETER OF THE TUBE(M)
14 FORMAT (///) EVAPORATOR LENGTH(M) CONDENSER LENGTH(M)
15 FORMAT (//E15.7,12X,E15.7)
17 FORMAT (///) THERMAL CONDUCTIVITY OF THE TUBE WALL(W/M-K)
19 FORMAT (///) RADIAL HEAT TRANSFER ACROSS THE TUBE WALL(W)
25 FORMAT (///) VAPOR TEMP. DROPIK EVAPORATOR FILM TEMP. DROPIK
1) CONDENSER FILM TEMP. DROPK)
26 FORMAT (//E15.7,14X,E15.7,23X,E15.7)
27 FORMAT (///) RAD.(STORAGE) TUBE THICKNESS TEMP. DROP ACROSS
1 TEMP. DROP ACROSS TOTAL TEMP.
29 FORMAT (1 (M) (M) THE EVAPORATOR WALL(K)
1 THE CONDENSER WALL(K) DROPIK)
82 FORMAT (//E15.7,2X,E15.7,14X,E15.7,6X,E15.7)
IF (OPWT-LT.1) GO TO 111
WRITE (6,87)
WRITE (6,88)
STHIK(1)=0.0
THICK(1)=TMIN
NHN=0
CONST=0.00206
II=1
IND=0
BAM=AW*10.76
RS=0.0
WTS=0.0
DELR=0.0
BOELM=DELM*3.281
BRHOM=RHOM*0.06243
BRHOL=RMOL*0.06243
BR=XID*3.281/2.0
BXID=XID*3.281
STRES=(STRES/(703.109.81))*144.0
BXLHP=XLHP*3.281
BRMAX=RMAX*3.261
BXOD=XOD*3.281
BTEMP=TEMP*1.8
BTMIN=TMIN*3.281
BXMFLD=XMFLD*2.205
IF (STATE.EQ.1) GO TO 32
WRITE (6,36)
SPVOL=((3.14159*XID**2/4.0)*XLHP*1000.0-VOW)/(XMFLD*1000.0/XMW)
A=ASO*(1.0-SA/SPVOL)
B=BSO*(1.0-SB/SPVOL)
EPSI=SC/(SPVOL*TEMP**3)
PRES=CONST*TEMP*(1.0-EPSI)*(SPVOL*B)/(SPVOL**2)-A/(SPVOL**2)
BPRES=PRES*14.7*144.0

```

C.I-55

```
GO TO 33
32 BPRES=BKXFL*1545.33*RTMP/(3.14159*BR*BR*BXLHP*XMW-VOW*XMW)
WRITE (6,37)
33 BTRED=BPRES*OR*FSAFE/STRES
IF (BTRED.GT.BTMIN) GO TO 16
IND=1
BTRED=BTMIN
16 TKED=BTRED*0.3048
THICK(1)=TRED
BVHP=3.14159*BXLMP*BR*BR-VOW
PRES=BPRES*703.1*9.8/144.0
WTL=XMFLD
WTH=RHOM*3.14159*(XID*TRED+TKED**2.0)*XLMP
IF (OTOW.EQ.5) GO TO 100
WT=WTH+WTL*WTH*WTS
GO TO 101
100 WTH=WTH+WTH
WT=WTH+WTL*WTS
101 IF (OTOW.NE.5) GO TO 3
WRITE (6,4) NCAAE
3 WRITE (6,46)
WRITE (6,45) FSAFE,TEMP
IF (OTOW.EQ.5) GO TO 21
WRITE (6,64)
WRITE (6,65) XMFLD,WTH
GO TO 22
21 WRITE (6,23)
WRITE (6,65) XMFLD
22 WRITE (6,78)
WRITE (6,79)
WRITE (6,303) RS,TRED,DELR,PRES,WTH,WTS,WT
IF (OPNT.LT.1) GO TO 2
IF (IND.EQ.1) GO TO 91
BINCR=(BRMAX-BR)/9.0
IF (BINCR.LT.0.0) GO TO 2
BVHP=BR*BR*3.14159*BXLMP-VOW
BRMAX=BR-BINCR
DO 50 I=1,10
BRMAX=BRMAX+BINCR
RS=BRMAX*0.3048
DH1=BRMAX-(BRMAX**2-BR**2)**0.5
BVST=4.0*3.14159*BRMAX**3/3.0-3.14159*DH1*(3.0*BR**2+DH1**2)/6.0
WVTT=BVHP+BVST
IF (STATE.EQ.1) GO TO 34
SPVOL=BVTT*0.02832*1000.0/(XMFLD*1000.0/XMW)
A=ASL*(1.0-SA/SPVOL)
U=BSU*(1.0-SH/SPVOL)
EPS1=SC/(SPVOL*TEMP**3)
PRES=CONST*TEMP*(1.0-EPS1)*(SPVOL+R)/(SPVOL**2)-A/(SPVOL**2)
HPRES=PRES*14.7*144.0
GO TO 35
34 HPRES=BKXFL *1545.33*RTMP/(8VTT*XMW)
35 BTRED=HPRES*OR*FSAFE/STRES
IF (BTRED.GT.BTMIN) GO TO 51
BTRED=PTMIN
NIN=5
51 DELLR=HPRES*HRMAX*FSAFE/(2.0*STRES)
IF (HDFLR.GT.HDELM) GO TO 52
```

```
HDELR=HDELM
52 RMAX=BRMAX*0.3048
TRED=BTRED*0.3048
DELR=HDELR*0.3048
I1=1+1
STHICK(I1)=RMAX
THICK(I1)=TRED
PRES=BPRES*703.1*9.8/144.0
HI=BHI*0.3048
WTH=RHOM*3.14159*(XID*TRED+TKED**2)*XLMP
WTS=(4.0*3.14159*(RMAX+DELR)**3/3.0-4.0*3.14159*RMAX**3/3.0)*RHOM
12.0*3.14159*RMAX*HI*DELR*RHOM
IF (CTOW.EQ.5) GO TO 30
WT=WTH+WTL*WTH*WTS
GO TO 31
30 WTH=WTH+WTH
WT=WTH+WTL*WTS
31 WRITE (6,303) RS,TRED,DELR,PRES,WTH,WTS,WT
IF (NIN.GT.1) GO TO 2
50 CONTINUE
GO TO 2
91 WRITE (6,92)
2 WRITE (6,87)
WRITE (6,11)
IF (OTOW.NE.5) GO TO 12
WRITE (6,4) NCAAE
12 WRITE (6,13)
WRITE (6,303) XID
WRITE (6,14)
WRITE (6,15) XLEV,XLCD
WRITE (6,17)
WRITE (6,303) WALLK
WRITE (6,19)
WRITE (6,303) QTRAN
WRITE (6,25)
WRITE (6,26) VTD,ETD,CTD
WRITE (6,27)
WRITE (6,29)
DO 28 J=1,11
DEXT=XID+2.0*THICK(J)
DINT=XID
AEXTE=DEXT*3.14159*XLEV
AEXTC=DEXT*3.14159*XLCD
EWD=QTRAN*DEXT*(ALOG(DEXT/DINT))/(2.0*WALLK*AEXTE)
CWD=QTRAN*DEXT*(ALOG(DEXT/DINT))/(2.0*WALLK*AEXTC)
YTD=VTD+ETD+CTD+EWD+CWD
WRITE (6,82) STHICK(J),THICK(J),EWD,CWD,YTD
28 CONTINUE
111 RETURN
END
```

Appendix D. Sample Problems

PRECEDING PAGE BLANK NOT FILMED

The first sample problem consists of determining the heat transport capability of an aluminum (6061-T6) heat pipe (1.27×10^{-2} m O.D. \times 8.9×10^{-4} m wall). A homogeneous circumferential porous wick (200-mesh stainless steel screen) is used in the heat pipe. The heat pipe working fluid is nitrogen at an operating temperature of 80°K , and the tube wall material is aluminum alloy 6061-T6. Heat load, elevation, maximum system temperature, and acceptable range of vapor temperature drop are specified as:

$$\begin{aligned}\dot{Q}_{\text{req'd}} &= 5\text{ W} \\ h &= 0.00254\text{ m} \\ T_{\text{max}} &= 300.0^{\circ}\text{K} \\ \Delta T_{\text{v}} &= 10.0^{\circ}\text{K}\end{aligned}$$

The length of the evaporator, adiabatic section and condenser of the heat pipe are specified as:

$$\begin{aligned}L_e &= 0.2\text{ m} \\ L_a &= 0.8\text{ m} \\ L_c &= 0.2\text{ m}\end{aligned}$$

The spherical storage reservoir, if needed for containment purposes, is specified to be 5.8×10^{-2} m in diameter and 8.9×10^{-4} m wall thickness. Finally, the effective thermal conductivity of the wick is assumed to be $0.14\text{ W/m}^{\circ}\text{K}$ (i.e., thermal conductivity of nitrogen). The associated data cards are listed in Table C.1-3. The resulting computer output data follow. As indicated in the printout, the maximum heat transport capability in a one "g" environment is approximately 0.98 watts, which is less than the required heat load. Therefore, weight and heat transfer analyses are not presented and the program terminates with the following statement: "No area exists to satisfy QMAX (w) requirement".

In the second sample problem, the performances of a nitrogen heat pipe with an axial rectangular grooved wick are considered. The maximum and minimum

allowable aspect ratios, land thicknesses, and widths of the grooves are specified as:

$$\phi_{\max} = 1.5$$

$$\phi_{\min} = 0.5$$

$$L_{\max} = 5.10 \times 10^{-4} \text{ m}$$

$$L_{\min} = 3.81 \times 10^{-4} \text{ m}$$

$$W_{\max} = 7.62 \times 10^{-4} \text{ m}$$

$$W_{\min} = 4.06 \times 10^{-4} \text{ m}$$

The heat load requirement is:

$$\dot{Q}_{\max} = 0.005 \text{ W}$$

and the evaporator and condenser film coefficient are assumed to be $380 \text{ W/m}^2\text{-}^\circ\text{K}$ and $760 \text{ W/m}^2\text{-}^\circ\text{K}$, respectively. These values are based on measured data. The other pertinent data remain unchanged and are specified in the first sample problem. It should be noted, however, that the properties of nitrogen are input here because of the option used in the control card. The associated data cards are listed in Table C.1-4. The resulting computer output data follow. Since the maximum heat transport capability in a one "g" environment of each specified aspect ratio is larger than the heat load requirement, the weight and heat transfer analyses are performed for each aspect ratio. The results of these analyses are presented in the computer output.

HEAT PIPE ANALYSIS AND DESIGN (HPAD)

INPUT DATA (HOMOGENEOUS WICK AGAINST THE WALL (200 MESH SCREEN))

HEAT PIPE PROPERTIES

TUBE MATERIAL ALUMINUM ALLOY 6061-T6

THERMAL CONDUCTIVITY (W/M-K)

.1600000+03

YIELD STRESS (N/M-M)

.2740000+04

DENSITY (KG/M-M-M)

.2700000+04

CONTAINER SAFETY FACTOR

2.00

OUTSIDE DIAMETER (M)

.1270000+01

MIN. WALL THICKNESS (M)

.8900000+03

LENGTH OF THE HEAT PIPE SECTIONS

EVAP (M)

.2000000+00

AD (M)

.4000000+00

COND (M)

.2000000+00

TOTAL (M)

.1200000+01

GEOMETRY OF THE STORAGE VOLUME

RADIUS (M) OF MAX. STORAGE VOLUME

.5800000+01

WICK GEOMETRY

HOMOGENEOUS WICK AGAINST THE WALL (200 MESH SCREEN)

VOID FRACTION OF THE WICK

.700

PERMEABILITY (M-M)

.2700000+10

EFF. PUMPING RAD. FOR HEAT TRANSPORT AND SELF-PRIMING (M)

.6850000+04

WIRE DIAMETER OF THE SCREEN (M)

.8330000+04

DENSITY OF THE SCREEN WIRE (KG/M-M-M)

.2850000+04

FLUID PROPERTIES

WORKING FLUID = NITROGEN AT 80.00(K)

MOLECULAR WEIGHT(KG/MOLE)

28.0

THE RATIO OF SPECIFIC HEATS(CP/CV)

1.404

EFFECTIVE THERMAL CONDUCTIVITY OF THE LIQUID AND THE WICK(W/M-K)

.140000+00

CONTACT ANGLE(DEG)

.000

SURFACE TENSION(N/M)

.620000+02

LATENT HEAT(J/KG)

.195000+04

LIQ. DENSITY(KG/M-M)

.802000+03

VAPOR DENSITY(KG/M-M)

.382000+01

LIQ. VISCOSITY(KG/M-S)

.141000+03

VAPOR VISCOSITY(KG/M-S)

.581000+05

LIQUID TRANSPORT FACTOR(W/M-H)

.9095021+10

PERFORMANCE REQUIREMENTS

MAXIM. REQUIREMENT (INCLUDING THE PERFORMANCE FACTOR) IS

.500000+01

THE PERFORMANCE FACTOR IS

1.00

ELEVATION(M)

.2540000+02

MAX. TEMPERATURE(K)

300.00

MAX. ALLOWABLE VAPOR TEMPERATURE DROP(K)

10.00

OUTPUT DATA

SELF-PRIMING REQUIREMENT (IN LG WITH ELEVATION OF .2540000-02(M))

MAX. CAPILLARY HEAD FOR SELF-PRIMING(M) REQUIRED HEAD(M) EQUIVALENT EFF. RAD. FOR SELF-PRIMING(M)
 .3096161-01 .1394000-01 .1650238-03

SONIC LIMITATION

SONIC VELOCITY(M/S) MINIMUM VAPOR AREA(M²) FOR SONIC LIMITATION
 .1826381-03 .5289449-07

HEAT TRANSPORT ANALYSIS (HOMOGENEOUS WICK AGAINST THE WALL (200 MESH SCREEN))

THICKNESS OF THE WICK (M)	VAPOR TEMP DROP (K)	EVAPORATOR TEMP DROP (K)	CONDENSER TEMP DROP (K)	(6-1) (ΔE/FF)MAX (W-M)	(6-1) QMAX (W)	(6-0) (ΔE/FF)MAX (W-M)	(6-0) QMAX (W)	(6-1) (Q/DH) (W/M)
.107-03	.962-07	.959-02	.959-02	.913-01	.913-01	.790-01	.790-01	~.293-01
.212-03	.992-07	.182-01	.182-01	.818-01	.818-01	.147-00	.147-00	~.981-01
.320-03	.160-04	.905-01	.905-01	.122-00	.122-00	.218-00	.218-00	~.715-01
.526-03	.220-04	.712-01	.712-01	.140-00	.140-00	.287-00	.287-00	~.999-01
.823-03	.310-04	.110-00	.110-00	.198-00	.198-00	.356-00	.356-00	~.117-02
.690-03	.901-04	.187-00	.187-00	.234-00	.234-00	.922-00	.922-00	~.139-02
.796-03	.807-04	.211-00	.211-00	.272-00	.272-00	.988-00	.988-00	~.160-02
.853-03	.628-04	.273-00	.273-00	.308-00	.308-00	.851-00	.851-00	~.181-02
.959-03	.767-04	.392-00	.392-00	.393-00	.393-00	.619-00	.619-00	~.202-02
.107-02	.928-04	.918-00	.918-00	.377-00	.377-00	.675-00	.675-00	~.221-02
.117-02	.111-04	.500-00	.500-00	.910-00	.910-00	.739-00	.739-00	~.291-02

CI-62

C1-63

•128-02	•132-05	•589-00	•589-00	•992-00	•992-00	•792-00	•792-00	•-260-02
•139-02	•154-05	•683-00	•683-00	•974-00	•974-00	•899-00	•899-00	•-279-02
•149-02	•167-05	•784-00	•784-00	•504-00	•504-00	•904-00	•904-00	•-297-02
•180-02	•221-05	•889-00	•889-00	•534-00	•534-00	•957-00	•957-00	•-314-02
•171-02	•261-05	•100-01	•100-01	•543-00	•543-00	•101-01	•101-01	•-331-02
•181-02	•307-05	•112-01	•112-01	•892-00	•892-00	•104-01	•104-01	•-348-02
•192-02	•362-05	•124-01	•124-01	•619-00	•619-00	•111-01	•111-01	•-364-02
•203-02	•424-05	•136-01	•136-01	•646-00	•646-00	•114-01	•114-01	•-380-02
•213-02	•503-05	•149-01	•149-01	•671-00	•671-00	•120-01	•120-01	•-395-02
•228-02	•574-05	•162-01	•162-01	•696-00	•696-00	•125-01	•125-01	•-410-02
•238-02	•703-05	•176-01	•176-01	•720-00	•720-00	•129-01	•129-01	•-424-02
•245-02	•835-05	•190-01	•190-01	•744-00	•744-00	•133-01	•133-01	•-437-02
•256-02	•993-05	•204-01	•204-01	•766-00	•766-00	•137-01	•137-01	•-451-02
•266-02	•119-09	•219-01	•219-01	•788-00	•788-00	•141-01	•141-01	•-463-02
•277-02	•192-09	•233-01	•233-01	•808-00	•808-00	•145-01	•145-01	•-476-02
•288-02	•171-09	•248-01	•248-01	•828-00	•828-00	•148-01	•148-01	•-487-02
•298-02	•207-09	•263-01	•263-01	•847-00	•847-00	•152-01	•152-01	•-498-02
•309-02	•253-09	•278-01	•278-01	•865-00	•865-00	•155-01	•155-01	•-509-02
•320-02	•310-09	•294-01	•294-01	•882-00	•882-00	•158-01	•158-01	•-519-02
•330-02	•383-09	•309-01	•309-01	•899-00	•899-00	•161-01	•161-01	•-529-02
•341-02	•477-09	•325-01	•325-01	•914-00	•914-00	•164-01	•164-01	•-537-02
•352-02	•579-09	•340-01	•340-01	•928-00	•928-00	•166-01	•166-01	•-546-02
•362-02	•761-09	•355-01	•355-01	•940-00	•940-00	•168-01	•168-01	•-553-02
•373-02	•979-09	•370-01	•370-01	•952-00	•952-00	•171-01	•171-01	•-560-02
•384-02	•127-03	•384-01	•384-01	•963-00	•963-00	•172-01	•172-01	•-565-02
•394-02	•169-03	•398-01	•398-01	•969-00	•969-00	•174-01	•174-01	•-570-02
•405-02	•227-03	•411-01	•411-01	•974-00	•974-00	•174-01	•174-01	•-573-02
•416-02	•311-03	•422-01	•422-01	•975-00	•975-00	•175-01	•175-01	•-573-02
•426-02	•434-03	•431-01	•431-01	•970-00	•970-00	•174-01	•174-01	•-571-02

0.737-02	0.625-01	0.936-01	0.936-01	0.925-00	0.958-00	0.172-01	0.172-01	-0.564-02
0.948-02	0.919-01	0.935-01	0.935-01	0.933-00	0.933-00	0.167-01	0.167-01	-0.549-02
0.958-02	0.138-02	0.929-01	0.929-01	0.888-00	0.888-00	0.159-01	0.159-01	-0.522-02
0.969-02	0.213-02	0.976-01	0.976-01	0.811-00	0.811-00	0.145-01	0.145-01	-0.477-02
0.980-02	0.227-02	0.993-01	0.993-01	0.688-00	0.688-00	0.123-01	0.123-01	-0.409-02
0.990-02	0.498-02	0.260-01	0.260-01	0.509-00	0.509-00	0.913-00	0.913-00	-0.300-02
0.801-02	0.675-02	0.157-01	0.157-01	0.301-00	0.301-00	0.539-00	0.539-00	-0.177-02
0.812-02	0.831-02	0.668-00	0.668-00	0.125-00	0.125-00	0.225-00	0.225-00	-0.738-01
0.822-02	0.914-02	0.170-00	0.170-00	0.312-01	0.312-01	0.559-01	0.559-01	-0.183-01
0.833-02	0.939-02	0.162-01	0.162-01	0.292-02	0.292-02	0.523-02	0.523-02	-0.172-00
0.844-02	0.972-02	0.179-01	0.179-01	0.307-05	0.307-05	0.551-05	0.551-05	-0.181-03

NO AREA EXISTS TO SATISFY MAXIMUM REQUIREMENT

CHARACTER REQUIREMENT (INCLUDING THE PERFORMANCE FACTOR) IS

0.000000-01

MAX. ALLOWABLE VAPOR TEMPERATURE DROP (K)

10.00

C.I-64

HEAT PIPE ANALYSIS AND DESIGN (HPAD)

INPUT DATA (AXIAL RECTANGULAR GROOVED HEAT PIPE)

HEAT PIPE PROPERTIES

TUBE MATERIAL ALUMINUM ALLOY 6061-T6

YIELD STRESS(N/M-M) DENSITY(KG/M-M-M) CONTAINER SAFETY FACTOR
.270000E+07 .270000E+04 2.00

OUTSIDE DIAMETER(M) MIN. WALL THICKNESS(M)
.127000E+01 .800000E-03

LENGTH OF THE HEAT PIPE SECTIONS

EVAP(M)	AD(M)	COND(M)	TOTAL(M)
.200000E+00	.400000E+00	.200000E+00	.120000E+01

REPRODUCIBILITY OF THE ORIGINAL PAGE IS POOR

GEOMETRY OF THE STORAGE VOLUME

RADIUS(M) OF MAX. STORAGE VOLUME
.500000E+01

PICK GEOMETRY

AXIAL RECTANGULAR GROOVED HEAT PIPE

THE MAX. AND MIN. VALUES OF ASPECT RATIO OF THE GROOVE(GROOVE DEPTH/GROOVE WIDTH)
.150000E+01 .500000E+00

THE MAX. AND MIN. VALUES OF THE GROOVE WIDTH(M)
.262000E+03 .400000E+03

THE MAX. AND MIN. VALUES OF THE LAND THICKNESS(M)
.810000E-03 .361000E-03

FLUID PROPERTIES

WORKING FLUID - NITROGEN AT 80.00(K)

MOLECULAR WEIGHT(KG/MOLE)

28.0

CONTACT ANGLE(DEG)

.000

THE RATIO OF SPECIFIC HEATS(CP/CV)

1.400

EVAPORATOR FILM COEFFICIENT(W/M-K)

.3800000+03

CONDENSER FILM COEFFICIENT(W/M-K)

.7600000+03

SURFACE TENSION(N/M)

.8200000-02

LATENT HEAT(J/KG)

.1950000+06

LIQ. DENSITY(KG/M-M-H)

.9000000+03

VAPOR DENSITY(KG/M-M-H)

.5900000+01

LIQ. VISCOSITY(KG/M-S)

.1498000-03

VAPOR VISCOSITY(KG/M-S)

.6890000-08

LIQUID TRANSPORT FACTOR(W/M-M)

.0134259+01

PERFORMANCE REQUIREMENTS

Q_{MAX}(%) REQUIREMENT (INCLUDING THE PERFORMANCE FACTOR) IS

.5000000+02

THE PERFORMANCE FACTOR IS

1.00

ELEVATION(M)

.2590000-02

MAX. TEMPERATURE(K)

300.00

MAX. ALLOWABLE VAPOR TEMPERATURE DROP(K)

14.00

INPUT DATA

SELF-PRIMING REQUIREMENT IS IN AIR ELEVATION OF .2540000-02(m)

THE ASPECT RATIOS OF THE GROOVE MAX. ALLOWABLE GROOVE WIDTH FOR SELF-PRIMING IS (GROOVE DEPTH/GROOVE WIDTH)

.50 .7211767-03

1.00 .6657892-03

1.50 .6043998-03

SONIC LIMITATION

SONIC VELOCITY(M/S) MINIMUM VAPOR AREA(M²) FOR SONIC LIMITATION

.1829377-03 .5210983-10

HEAT TRANSPORT ANALYSIS OF RECTANGULAR GROOVED HEAT PIPE

CASE NO.	GROOVE NO.	ASPECT RATIO (DEPTH/WIDTH)	GROOVE WIDTH(M)	LAND THICKNESS(M)	(4-1)		(6-0)		(6-1)
					QMAX (W)	QMAX (R)	QMAX (W)	QMAX (R)	Q/DH (W/M)
1	38	1.50	.906-03	.396-03	.179-01	.179-01	.857-01	.857-01	.6871703
2	40	1.00	.906-03	.388-03	.822-00	.822-00	.192-01	.192-01	.6371103
3	33	.50	.584-03	.900-03	.122-00	.122-00	.882-00	.882-00	.6182103

QMAX(R) REQUIREMENT (INCLUDING THE PERFORMANCE FACTOR) IS

.5000000-02

THE PERFORMANCE FACTOR IS

1.00

THE CASES WHICH SATISFY THE QMAX(R) REQUIREMENT ARE LIST AS FOLLOWS

CASE NO.	GROOVE NO.	ASPECT RATIO (DEPTH/WIDTH)	GROOVE WIDTH(M)	LAND THICKNESS (M)	QMAX (W)	MASS OF THE FLUID(KG)	VAPOR TEMP. DROP(C)	EVAPORATOR TEMP DROP(K)	CONDENSER TEMP DROP(K)	(6-1)
										Q/DH (W/M)
1	38	1.50	.906-03	.396-03	.179-01	.918-02	.287-05	.845-00	.392-00	.6871703
2	40	1.00	.906-03	.388-03	.822-00	.594-02	.212-05	.715-00	.158-00	.6371103
3	33	.50	.584-03	.900-03	.122-00	.394-02	.151-05	.847-01	.234-01	.6182103

C.1-67

WIGHT ANALYSIS FOR THE SYSTEM

EQUATION OF STATE FOR IDEAL GAS IS USED TO CALCULATE THE INTERNAL PRESSURE

CASE NUMBER 1

SAFETY FACTOR MAXIMUM TEMPERATURE(K)

2.00 300.00

LIQUID WT. (KG)

.9170309-02

HAD. STORAGE	TUBE THICKNESS	ST. THICKNESS	PRESSURE	HEAT PIPE WT.	STORAGE WT.	TOTAL WT.
(M)	(M)	(M)	(N/M-M)	(KG)	(KG)	(KG)
.0000000	.0900434-03	.0000000	.7254262+07	.1393378+00	.0000000	.1487162+00

NO STORAGE VOLUME IS NEEDED

THERMAL ANALYSIS FOR THE SYSTEM

CASE NUMBER 1

INSIDE DIAMETER OF THE TUBE(M)

.1092000-01

EVAPORATOR LENGTH(M) CONDENSER LENGTH(M)

.2000000-00 .2000000-00

THERMAL CONDUCTIVITY OF THE TUBE WALL(N/M-K)

.1600000-03

RADIAL HEAT TRANSFER ACROSS THE TUBE WALL(W)

.5000000-02

VAPOR TEMP. DROP(K) EVAPORATOR FILM TEMP. DROP(K) CONDENSER FILM TEMP. DROP(K)

.2871984-05 .6848288+00 .3424193+00

HAD. STORAGE	TUBE THICKNESS	TEMP. DROP ACROSS	TEMP. DROP ACROSS	TOTAL TEMP.
(M)	(M)	THE EVAPORATOR WALL(K)	THE CONDENSER WALL(K)	DROP(K)
.0000000	.0900434-03	.3755385-05	.3755385-05	.7510770-05

C.I-68

WEIGHT ANALYSIS FOR THE SYSTEM

EQUATION OF STATE FOR IDEAL GAS IS USED TO CALCULATE THE INTERNAL PRESSURE

CASE NUMBER 2

SAFETY FACTOR MAXIMUM TEMPERATURE(K)

2.00 300.00

LIQUID WT. (KG)

.000000E+00

RAD. STORAGE (M)	TUBE THICKNESS (M)	SP. THICKNESS (M)	PRESSURE (N/M ²)	HEAT PIPE WT. (KG)	STORAGE WT. (KG)	TOTAL WT. (KG)
------------------	--------------------	-------------------	------------------------------	--------------------	------------------	----------------

.0000000	.0000000	.0000000	.0713091E+07	.1297720E+00	.0000000	.1397360E+00
----------	----------	----------	--------------	--------------	----------	--------------

NO STORAGE VOLUME IS NEEDED

THERMAL ANALYSIS FOR THE SYSTEM

CASE NUMBER 2

INSIDE DIAMETER OF THE TUBE (M)

.100000E+01

EVAPORATOR LENGTH (M) CONDENSER LENGTH (M)

.200000E+00 .200000E+00

THERMAL CONDUCTIVITY OF THE TUBE WALL (W/M-K)

.160000E+03

RADIAL HEAT TRANSFER ACROSS THE TUBE WALL (W)

.500000E+02

VAPOR TEMP. (K) EVAPORATOR FILM TEMP. (K) CONDENSER FILM TEMP. (K)

.112310E+05 .215422E+00 .137731E+00

RAD. STORAGE (M)	TUBE THICKNESS (M)	TEMP. DROP ACROSS THE EVAPORATOR WALL (K)	TEMP. DROP ACROSS THE CONDENSER WALL (K)	TOTAL TEMP. (K)
------------------	--------------------	---	--	-----------------

.0000000	.0000000	.0755385E+05	.0755385E+05	.0755385E+05
----------	----------	--------------	--------------	--------------

C.I-69

FOR PROSECUTION
ORIGINAL PAGE IS POOR

WEIGHT ANALYSIS FOR THE SYSTEM

EQUATION OF STATE FOR IDEAL GAS IS USED TO CALCULATE THE INTERNAL PRESSURE

CASE NUMBER 3

SAFETY FACTOR MAXIMUM TEMPERATURE(K)

2.00 300.00

LIQUID WT.(KG)

.3938399-02

RAD. (STORAGE) (M)	TUBE THICKNESS (M)	ST. THICKNESS (M)	PRESSURE (N/M ²)	HEAT PIPE WT. (KG)	STORAGE WT. (KG)	TOTAL WT. (KG)
.0000000	.8900434-03	.0000000	.3111146-07	.1234177-00	.0001000	.1273641-00

NO STORAGE VOLUME IS NEEDED

THEMAL ANALYSIS FOR THE SYSTEM

CASE NUMBER 3

INSIDE DIAMETER OF THE TUBE(M)

.1092000-01

EVAPORATOR LENGTH(M) CONDENSER LENGTH(M)

.2000000-00 .2000000-00

THERMAL CONDUCTIVITY OF THE TUBE WALL(N/M-K)

.1600000-03

RADIAL HEAT TRANSFER ACROSS THE TUBE WALL(W)

.5000000-02

VAPOR TEMP. DROP(K) EVAPORATOR FILM TEMP. DROP(K) CONDENSER FILM TEMP. DROP(K)

.1513032-06 .4671895-01 .2335923-01

RAD. (STORAGE) TUBE THICKNESS TEMP. DROP ACROSS THE EVAPORATOR WALL(K) TEMP. DROP ACROSS THE CONDENSER WALL(K) TOTAL TEMP. DROP(K)

.0000000 .8900434-03 .3755305-05 .3755186-05 .7085334-01

C.I.-70

C.2 DATA ACQUISITION CODE USER'S MANUAL

C.2.1 Introduction

This section describes the utilization of the Data Acquisition Code (DAC). Basically, DAC generates the thermophysical properties of various heat pipe working fluids at saturation conditions. The fluids selected are those most commonly used and span the range from cryogenics to liquid metals. Both constant properties and temperature dependent properties are stored in the property subroutines of the DAC. Properties are stored as tabular data points or, in the case of the liquid metals, in functional form. Also, derived properties (e. g., liquid transport factor) are calculated and output by the code.

This code can be used alone to obtain fluid property data or can be used in combination with the Heat Pipe Analysis and Design (HPAD) Code and thereby reduce the amount of input data required.

The program input requirements are described in Section C.2.2.2, and the output formats are described in Section C.2.2.3. References are listed at the end of Section C.3. The flow diagram and program listing are presented in the Appendices. A list of Fortran names with physical or engineering quantities is also presented as an Appendix.

C.2.2 Program Description

C.2.2.1 General

The program logic is illustrated in the flow diagram contained in Appendix A. The FORTRAN names and the physical quantities they represent are listed in Appendix B. Storage requirements are on the order of 50,000 words (octal). A listing of the program is presented in Appendix C. The program was written in FORTRAN V and was designed to operate on the UNIVAC 1108 system.

Basically, the program reads the input control data, generates the thermophysical properties of the specified fluid, and outputs the property data. The deck set-up as shown in Figure C.2-1 consists of job control cards, the program source deck,

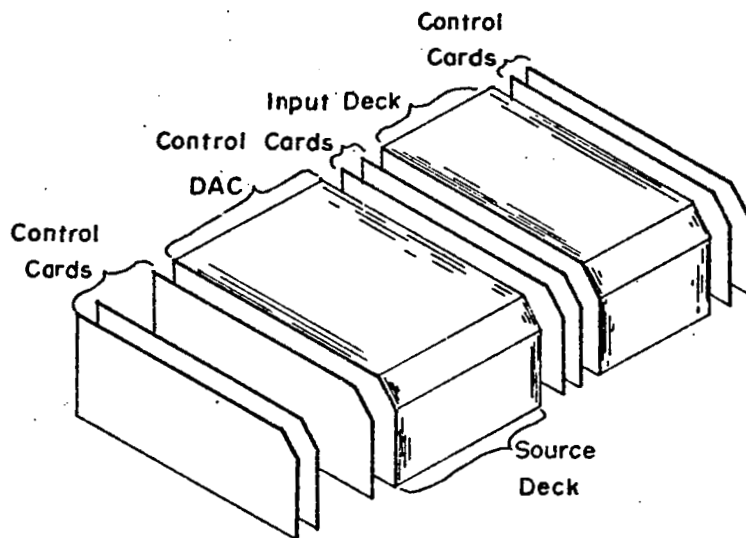

Figure C. 2-1. Program Deck Setup

additional control cards followed by the input control card and program termination cards. The program has two major options. First, the thermophysical properties can be determined at a specified temperature or at specified intervals over a specified range. If the specified temperature range is out of property data limits, the program will automatically adjust the range to be consistent with the available property data. The second option consists of having the property data output in scientific units (SI) or in both scientific and engineering units.

C.2.2.2 Input Description

Table C.2-2 describes the entries to be made on the various input cards and indicates when each of the optional cards are to be excluded. The FORTRAN name, format, and units to be used are indicated for each entry. A listing of sample input data for different cases is presented below in Table C.2-1.

Table C.2-1. Sample Input Data

```
2
4
1 2
320.0
3
4
2 1
200.0      350.      10.
```

C.2.2.3 Output Description

The program outputs essentially all the thermophysical fluid properties as well as derived properties needed for the Heat Pipe Analysis and Design Code. These properties are divided into two categories in the output. First, the constant properties which consist of the following:

- Molecular weight
- Gas constant
- Ratio of specific heats

Table C. 2-2. Input Data Description

<u>Input Card No.</u>	<u>Format</u>	<u>Fortran Name</u>	<u>Description</u>	<u>Units</u>
1	I3	MORE	Control Point, integer = 0 for last set of data, otherwise integer = 2	-
2	I3	FLUID	Control Point, type of working fluid .1 Hydrogen .2 Nitrogen .3 Oxygen .4 Water .5 Ammonia .6 Methanol .7 Acetone .8 Freon-21 .9 Sodium 10 Potassium 11 Lithium 12 Mercury	-
3	2I3	POINT	Control Point, integer = 1 for fluid properties at a temperature, otherwise integer = 2	-
		UNITS	Control Point, integer = 1 for M.K.S. units, integer = 2 for both M.K.S. and Engineering units	-
4*	F10.4	TEMP	Temperature (for fluid properties)	°K
5**	3F10.4	TMIN	Minimum temperature (for fluid properties)	°K
		TMAX	Maximum temperature (for fluid properties)	°K
		DT	Temperature increment (for fluid properties)	°K
6***	3F10.4	TMIN	Minimum temperature (for fluid properties)	°F
		TMAX	Maximum temperature (for fluid properties)	°F
		DT	Temperature increment (for fluid properties)	°F

- * Card 4 is needed only when the value of card 3 (1) is an integer equal to unity.
- ** Card 5 is needed only when the value of card 3 (2) is an integer equal to two.
- *** Card 6 is needed only when both values of card 3 are equal to two.

- Normal melting point
- Normal boiling point
- Critical temperature
- Critical pressure

The second category listed below consists of the temperature dependent properties and includes the derived data.

- Vapor pressure
- Liquid density
- Vapor density
- Surface tension of liquid
- Latent heat of vaporization
- Thermal conductivity of liquid
- Dynamic viscosity of liquid
- Kinematic viscosity of liquid
- Dynamic viscosity of vapor
- Kinematic viscosity of vapor
- Ratio of kinematic viscosity (vapor/liquid)
- Wicking height factor
- Liquid transport factor
- Sonic heat flux
- Sonic velocity

A listing of output data associated with the sample input data of Table C.2-1 is presented in Table C.2-3. If the specified temperature is outside of the data range it will be indicated in the output by "TEMPERATURE OUT OF TABLE RANGE".

DATA ACQUISITION CODE (DAC)

M. K. S. UNITS

FLUID WATER

CHEMICAL FORMULA H₂O

CONSTANT PROPERTIES

MOLECULAR WEIGHT (KG/MOLE)	GAS CONSTANT (M ³ M/KG-K)	RATIO OF SPECIFIC HEATS	
18.010	461.6840103	1.330	
NORMAL MELTING POINT (K)	NORMAL BOILING POINT (K)	CRITICAL TEMP (K)	CRITICAL PRESSURE (N/M ²)
273.150	373.140	647.000	221.000

TEMPERATURE-DEPENDENT PROPERTIES

TEMPERATURE (KELVIN)	320.0
VAPOR PRESSURE (N/M ²)	10 ⁻⁰⁵
LIQUID DENSITY (KG/M ³)	999.03
VAPOR DENSITY (KG/M ³)	70 ⁻⁰¹
SURFACE TENSION (N/M)	68 ⁻⁰¹
LATENT HEAT (J-KG)	24 ⁻⁰⁷
THERMAL CONDUCTIVITY OF LIQUID (W/M-K)	63 ⁻⁰⁰
DYNAMIC VISCOSITY OF LIQUID (KG/M-S)	59 ⁻⁰³
KINEMATIC VISCOSITY OF LIQUID (M ² /S)	59 ⁻⁰⁶
DYNAMIC VISCOSITY OF VAPOR (KG/M-S)	11 ⁻⁰⁴
KINEMATIC VISCOSITY OF VAPOR (M ² /S)	16 ⁻⁰³
RATIO OF KINEMATIC VISCOSITIES (VAPOR/LIQUID)	27 ⁻⁰³
WICKING HEIGHT FACTOR (M-M)	70 ⁻⁰⁵
LIQUID TRANSPORT FACTOR (M/M-M)	27 ⁻¹²
SONIC HEAT FLUX (W/M ²)	34 ⁻⁰⁸
SONIC VELOCITY (M/S)	44 ⁻⁰³

REPRODUCIBILITY OF THE ORIGINAL PAGE IS POOR.

Table C.2-3. Sample Output Data

DATA ACQUISITION CODE (DAC)

ENGINEERING UNITS

FLUID = WATER

CHEMICAL FORMULA = H₂O

CONSTANT PROPERTIES

MOLECULAR WEIGHT (LBM/MOLE)	GAS CONSTANT (FT-LBF/LBM-F)	RATIO OF SPECIFIC HEATS
18.000	85.8516665	1.330

NORMAL MELTING POINT (F)	NORMAL BOILING POINT (F)	CRITICAL TEMP (F)	CRITICAL PRESSURE (PSI)
32.018	212.018	704.930	325.009

TEMPERATURE-DEPENDENT PROPERTIES

TEMPERATURE (FAHRENHEIT)	116.3
VAPOR PRESSURE (PSI)	0.15001
LIQUID DENSITY (LBM/FT-FT-FT)	0.62002
VAPOR DENSITY (LBM/FT-FT-FT)	0.03002
SURFACE TENSION (LBF/FT)	0.96002
LATENT HEAT (BTU/LBM)	0.10009
THERMAL CONDUCTIVITY OF LIQUID (BTU/HR-FT-F)	0.37000
DYNAMIC VISCOSITY OF LIQUID (LBM/FT-HR)	0.15001
KINEMATIC VISCOSITY OF LIQUID (FT-FT/HR)	0.23001
DYNAMIC VISCOSITY OF VAPOR (LBM/FT-HR)	0.27001
KINEMATIC VISCOSITY OF VAPOR (FT-FT/HR)	0.41001
RATIO OF KINEMATIC VISCOSITIES (VAPOR/LIQUID)	0.27003
WICKING HEIGHT FACTOR (FT-FT)	0.75004
LIQUID TRANSPORT FACTOR (BTU/HR-FT-FT)	0.87011
SONIC HEAT FLUX (BTU/HR-FT-FT)	0.11008
SONIC VELOCITY (FT/HR)	0.52007

Table C.2-3. Sample Output Data (Continued)

DATA ACQUISITION CODE (DAC)

M, K, S, UNITS

FLUID = WATER

CHEMICAL FORMULA = H2O

CONSTANT PROPERTIES

MOLECULAR WEIGHT (KG/MOLE)

GAS CONSTANT (N-M/KG-K)

RATIO OF SPECIFIC HEATS

18.000

461.8840103

1.330

NORMAL MELTING POINT (K)

NORMAL BOILING POINT (K)

CRITICAL TEMP (K)

CRITICAL PRESSURE (N/M-M)

273.160

373.160

647.000

221.08

Table C.2-3: Sample Output Data (Continued)

REPRODUCIBILITY OF THE
DATA IN THIS REPORT

C.2-8

TEMPERATURE DEPENDENT PROPERTIES

TEMPERATURE (KELVIN)	280.0	290.0	300.0	310.0	320.0	330.0	340.0	350.0
VAPOR PRESSURE (N/M ²)	.97+03	.19+04	.35+04	.59+04	.10+05	.16+05	.26+05	.42+05
LIQUID DENSITY (KG/M ³)	.10+04	.10+04	.99+03	.99+03	.99+03	.98+03	.98+03	.97+03
VAPOR DENSITY (KG/M ³)	.74+02	.19+01	.25+01	.42+01	.70+01	.11+00	.17+00	.25+00
SURFACE TENSION (N/M)	.74+01	.73+01	.71+01	.69+01	.68+01	.66+01	.64+01	.63+01
LATENT HEAT (J/KG)	.25+07	.25+07	.24+07	.24+07	.24+07	.24+07	.23+07	.23+07
THERMAL CONDUCTIVITY OF LIQUID (W/M-K)	.59+00	.60+00	.61+00	.62+00	.63+00	.65+00	.66+00	.67+00
DYNAMIC VISCOSITY OF LIQUID (KG/M-S)	.14+02	.11+02	.83+03	.71+03	.58+03	.49+03	.43+03	.37+03
KINEMATIC VISCOSITY OF LIQUID (M ² /S)	.14+05	.11+05	.83+06	.71+06	.59+06	.50+06	.44+06	.38+06
DYNAMIC VISCOSITY OF VAPOR (KG/M-S)	.77+05	.10+04	.10+04	.11+04	.11+04	.11+04	.12+04	.12+04
KINEMATIC VISCOSITY OF VAPOR (M ² /S)	.13+02	.73+03	.41+03	.25+03	.16+03	.10+03	.70+04	.48+04
RATIO OF KINEMATIC VISCOSITIES (VAPOR/LIQUID)	.90+03	.64+03	.49+03	.36+03	.27+03	.21+03	.16+03	.13+03
WICKING HEIGHT FACTOR (M-M)	.76+05	.74+05	.73+05	.71+05	.70+05	.69+05	.67+05	.66+05
LIQUID TRANSPORT FACTOR (M/M-M)	.13+12	.14+12	.21+12	.23+12	.27+12	.31+12	.34+12	.38+12
SONIC HEAT FLUX (W/M-M)	.36+07	.64+07	.12+08	.20+08	.34+08	.54+08	.82+08	.12+09
SONIC VELOCITY (M/S)	.91+03	.97+03	.93+03	.94+03	.94+03	.95+03	.96+03	.96+03

Table C.2-3. Sample Output Data (Continued)

Appendix A. Flow Diagram for Data Acquisition Code

PRECEDING PAGE BLANK NOT FILMED

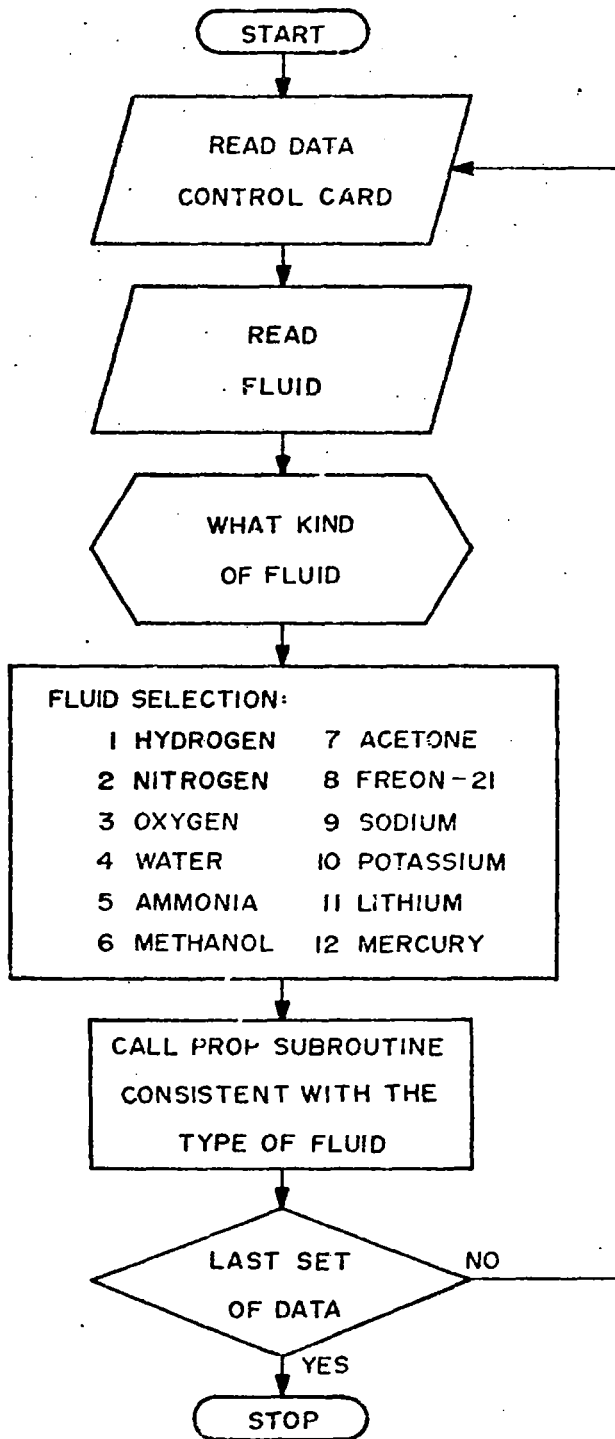

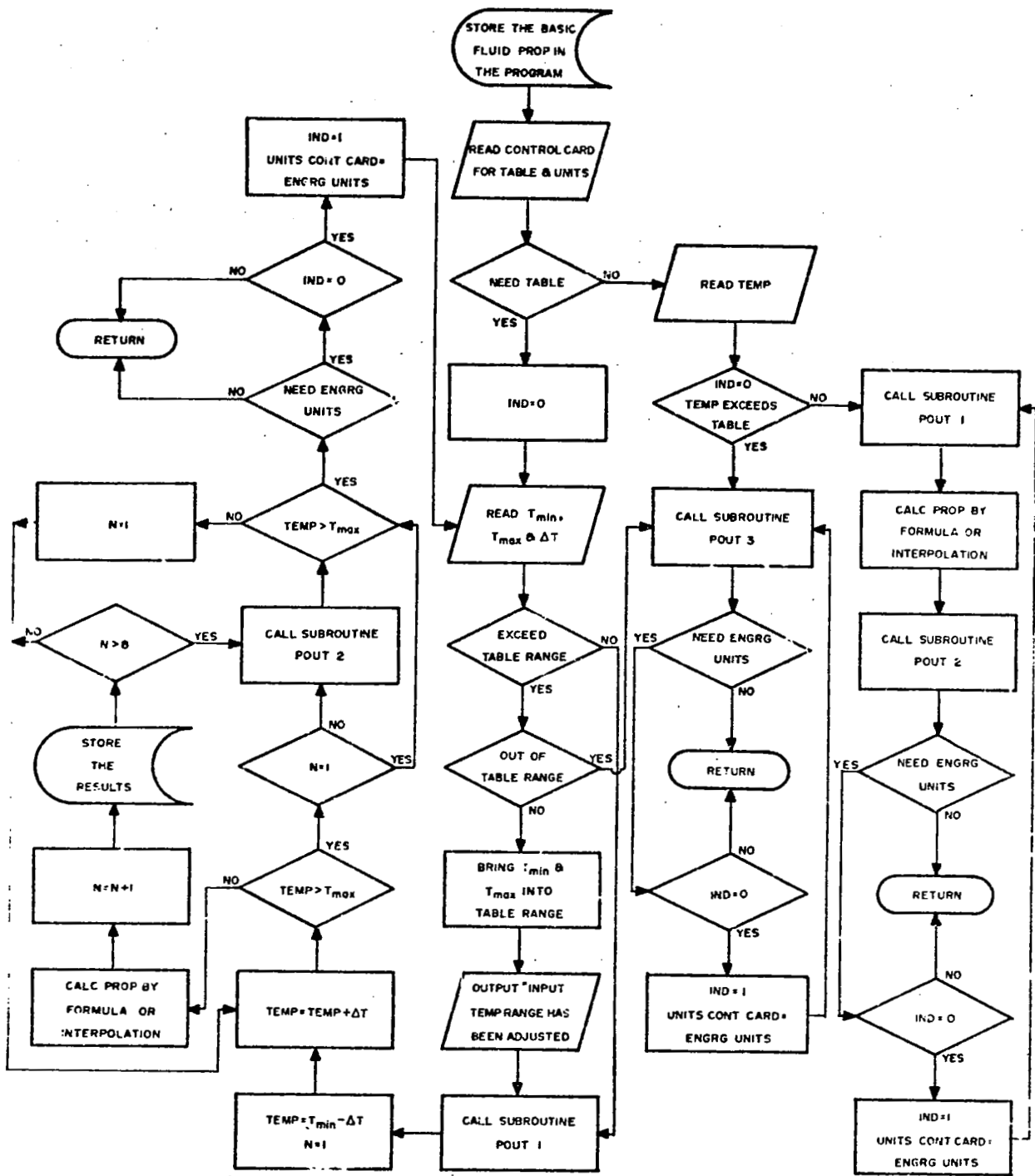

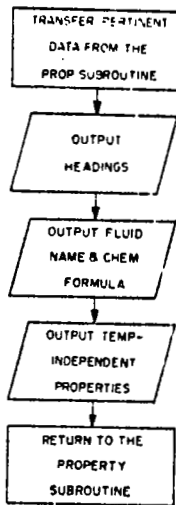

C-2-14

SUBROUTINE POUT 1

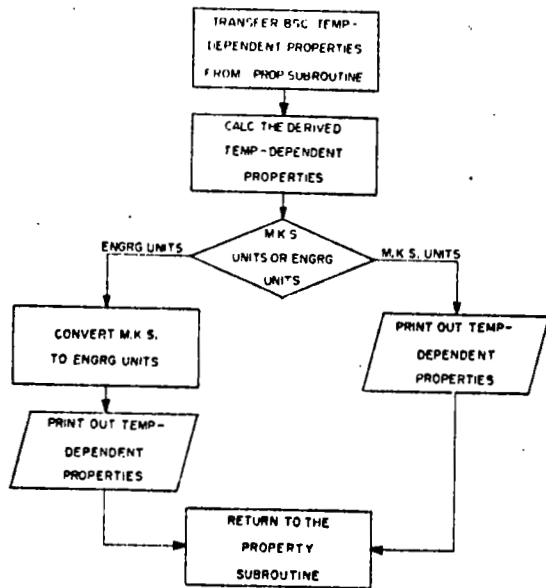

SUBROUTINE POUT 2

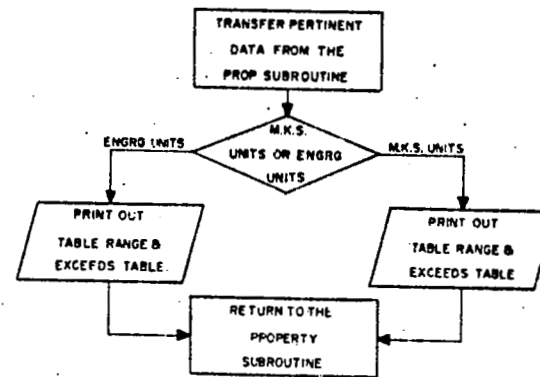

SUBROUTINE POUT 3

REPRODUCED FROM THE ORIGINAL MICROFILM

**Appendix B. FORTRAN Names
and Associated Physical or Engineering Quantities**

<u>Fortran Name</u>	<u>Description</u>	<u>Units</u>
MORE	Control Point, integer = 0 for last set of data, otherwise integer = 2	-
FLUID	Control Point, type of working fluid	-
	1 Hydrogen	
	2 Nitrogen	
	3 Oxygen	
	4 Water	
	5 Ammonia	
	6 Methanol	
	7 Acetone	
	8 Freon-21	
	9 Sodium	
	10 Potassium	
	11 Lithium	
	12 Mercury	
LOUT	Out of temperature range indicator	
LSUPP	Control Point, suppress DAC external output	
ARHOL	Liquid density	kg/m ³
ARHOV	Vapor density	kg/m ³
AXLAM	Latent heat of evaporation	W s/kg
ASIGM	Surface tension	N/m
AXMUL	Dynamic liquid viscosity	kg/m s
AXMUV	Dynamic vapor viscosity	kg/m s
TEMP	Temperature	^o K
APRESS	Vapor pressure	N/m ²
XMW	Molecular weight	kg/mole
GAMMA	Ratio of specific heat	-
ORHOL	Liquid density	kg/m ³
ORHOV	Vapor density	kg/m ³

<u>Fortran Name</u>	<u>Description</u>	<u>Units</u>
OSIGM	Surface tension	N/m
OXMUL	Dynamic liquid viscosity	kg/m s
OXMUV	Dynamic vapor viscosity	kg/m s
OPRES	Vapor pressure	N/m ²
OXLAM	Latent heat of evaporation	W s/kg
POINT	Control Point, integer = 1 for data at a temperature, otherwise integer = 2	-
UNITS	Control Point, integer = 1 for M.K.S. units, integer = 2 for M.K.S. and British units	-
HD	Headings (working fluid and chemical formula)	-
GAS	Gas constant	ft lbf/lbm ^o F atm liter/gm ^o K
TMELT	Normal melting point	^o K, ^o F
TBOIL	Normal boiling point	^o K, ^o F
TCRIT	Critical temperature	^o K, ^o F
PCRIT	Critical pressure	N/m ² , psi
NK	Control Point	-
OTEMP	Temperature	^o K
OTHCL	Thermal conductivity	W/m ^o K
OXNUL	Kinematic liquid viscosity	m ² /s
OXNUV	Kinematic vapor viscosity	m ² /s
RATIO	Ratio of kinematic viscosities (vapor/liquid)	-
OXNL	Liquid transport factor	W/m ²
OH	Wicking height factor	m ²
NBRIT	Counter for units used	-

<u>Fortran Name</u>	<u>Description</u>	<u>Units</u>
SONIC	Sonic velocity	m/s
OSHF	Sonic heat flux	W/m ²
BTEMP	Temperature	°F
BPRES	Vapor pressure	psi
BRHOL	Liquid density	lbm/ft ³
BRHOV	Vapor density	lbm/ft ³
BSIGM	Surface tension	lbf/ft
BXLAM	Latent heat of vaporization	Btu/lbm
BXMUL	Dynamic liquid viscosity	lbm/ft hr
BXMUV	Dynamic vapor viscosity	lbm/ft hr
BXNUL	Kinematic liquid viscosity	ft ² /hr
BXNUV	Kinematic vapor viscosity	ft ² /hr
BXNL	Liquid transport factor	Btu/hr ft ²
BH	Wicking height factor	ft ²
BSONI	Sonic velocity	ft/hr
BOSHF	Sonic heat flux	Btu/hr ft ²
BTHCL	Thermal conductivity of liquid	Btu/hr ft °F
TMI3	Storage space for temperature	°K, °F
TMA4	Storage space for temperature	°K, °F
T1	Storage space for temperature	°K, °F
T2	Storage space for temperature	°K, °F
XTEMP	Temperature	°K
RHOL	Liquid density	kg/m ³

<u>Fortran Name</u>	<u>Description</u>	<u>Units</u>
RHOV	Vapor density	kg/m ³
SIGMA	Surface tension	N/m
XLAMD	Latent heat of vaporization	W s/kg
XMUL	Dynamic liquid viscosity	kg/m s
XMUV	Dynamic vapor viscosity	kg/m s
THECL	Thermal conductivity	W/m °K
PRESS	Vapor pressure	N/m ²
MM	Number of data points	-
IND	Counter for output format	-
NIND	Counter for interpolation method	-
TMIN	Minimum temperature	°K
TMAX	Maximum temperature	°K
DT	Temperature increment	°K
A1	Storage space for temperature	°K
A2	Storage space for temperature	°K

Appendix C. Program Listing of Data Acquisition Code

PRECEDING PAGE BLANK NOT FILMED

```

INTEGER FLUID
20 READ (5,10) MURE
   READ (5,10) FLUID
10 FORMAT (3I3)
   LCHT=0
   LSUPP=0
   CALL DAC (FLUID,LSUPP,LOUT,ARHOL,ORHOV,AXLAM,ASIGN,AXMUL,AX
   IMUV,TEMP,APRES,XMW,GAMMA)
   IF (MURE.GT.1) GO TO 20
   STOP
END

```

```

SUBROUTINE DAC (FLUID,LSUPP,LOUT,ARHOL,ORHOV,AXLAM,ASIGN,AXMUL,AX
IMUV,TEMP,APRES,XMW,GAMMA)
DIMENSION ORHOL(8),ORHOV(8),OSIGN(8),OXMUL(8),OXMUV(8),OPRES(8)
DIMENSION OXLAM(8)
INTEGER FLUID,POINT,UNITS
IF (LSUPP.LT.2) GO TO 301
NBRIT=0
POINT=1
UNITS=1
301 GO TO (1,2,3,4,5,6,7,8,9,10,11,12),FLUID
1 CALL HYDRO (LSUPP,LOUT,NBRIT,POINT,UNITS,ORHOL,ORHOV,OXLAM,D
   ISIGN,OXMUL,OXMUV,TEMP,OPRES,XMW,GAMMA)
   GO TO 303
2 CALL NITRO (LSUPP,LOUT,NBRIT,POINT,UNITS,ORHOL,ORHOV,OXLAM,D
   ISIGN,OXMUL,OXMUV,TEMP,OPRES,XMW,GAMMA)
   GO TO 303
3 CALL OXYGE (LSUPP,LOUT,NBRIT,POINT,UNITS,ORHOL,ORHOV,OXLAM,D
   ISIGN,OXMUL,OXMUV,TEMP,OPRES,XMW,GAMMA)
   GO TO 303
4 CALL WATER (LSUPP,LOUT,NBRIT,POINT,UNITS,ORHOL,ORHOV,OXLAM,D
   ISIGN,OXMUL,OXMUV,TEMP,OPRES,XMW,GAMMA)
   GO TO 303
5 CALL AMMON (LSUPP,LOUT,NBRIT,POINT,UNITS,ORHOL,ORHOV,OXLAM,D
   ISIGN,OXMUL,OXMUV,TEMP,OPRES,XMW,GAMMA)
   GO TO 303
6 CALL METHA (LSUPP,LOUT,NBRIT,POINT,UNITS,ORHOL,ORHOV,OXLAM,D
   ISIGN,OXMUL,OXMUV,TEMP,OPRES,XMW,GAMMA)
   GO TO 303
7 CALL ACETO (LSUPP,LOUT,NBRIT,POINT,UNITS,ORHOL,ORHOV,OXLAM,D
   ISIGN,OXMUL,OXMUV,TEMP,OPRES,XMW,GAMMA)
   GO TO 303
8 CALL FREZ1 (LSUPP,LOUT,NBRIT,POINT,UNITS,ORHOL,ORHOV,OXLAM,D
   ISIGN,OXMUL,OXMUV,TEMP,OPRES,XMW,GAMMA)
   GO TO 303
9 CALL SODIU (LSUPP,LOUT,NBRIT,POINT,UNITS,ORHOL,ORHOV,OXLAM,D
   ISIGN,OXMUL,OXMUV,TEMP,OPRES,XMW,GAMMA)
   GO TO 303
10 CALL PUTAS (LSUPP,LOUT,NBRIT,POINT,UNITS,ORHOL,ORHOV,OXLAM,D
   ISIGN,OXMUL,OXMUV,TEMP,OPRES,XMW,GAMMA)
   GO TO 303
11 CALL LITHI (LSUPP,LOUT,NBRIT,POINT,UNITS,ORHOL,ORHOV,OXLAM,D
   ISIGN,OXMUL,OXMUV,TEMP,OPRES,XMW,GAMMA)
   GO TO 303
12 CALL MERCU (LSUPP,LOUT,NBRIT,POINT,UNITS,ORHOL,ORHOV,OXLAM,D

```

```

   ISIGN,OXMUL,OXMUV,TEMP,OPRES,XMW,GAMMA)
303 ARHOL=ORHOL(1)
   ARHOV=ORHOV(1)
   ASIGN=OSIGN(1)
   AXMUL=OXMUL(1)
   AXMUV=OXMUV(1)
   APRES=OPRES(1)
   AXLAM=OXLAM(1)
304 RETURN
END

```

```

SUBROUTINE POUT(HD,XMW,TMELT,TBOIL,TCRIT,PCRIT,NBRIT,GAMMA,LSUP
DIMENSION HD(2,2)
35 FORMAT (11)
36 FORMAT (////' DATA ACQUISITION CODE (DAC)
37 FORMAT (////' FLUID =,2A6.9X,1BHCHEMICAL FORMULA =,2A6)
45 FORMAT (///' M. K. S. UNITS')
38 FORMAT (////' CONSTANT PROPERT I
   1 S')
39 FORMAT (////' MOLECULAR WEIGHT (KG/MOLE) GAS CONSTANT(M-KG-
   1 RATIO OF SPECIFIC HEATS')
40 FORMAT (/F14.3,22X,F14.7,17X,F14.3)
41 FORMAT (////' NORMAL MELTING POINT(K) NORMAL BOILING POINT(K)
   1 CRITICAL TEMP(R) CRITICAL PRESSURE(N/M-MI)')
42 FORMAT (/F13.3,7X,F19.3,7X,F21.3,6X,E16.3)
46 FORMAT (///' ENGINEERING UNITS')
50 FORMAT (////' MOLECULAR WEIGHT (LBM/MOLE) GAS CONSTANT (FT-LBF.
   1BM-F) RATIO OF SPECIFIC HEATS')
51 FORMAT (////' NORMAL MELTING POINT(F) NORMAL BOILING POINT(F)
   1 CRITICAL TEMP(F) CRITICAL PRESSURE(PSI)')
IF (LSUPP.GT.1) GO TO 44
IF (NBRIT.EQ.1) GO TO 43
WRITE (6,35)
WRITE (6,36)
WRITE (6,45)
WRITE (6,37) (HD(1,1),I=1,2),HD(1,2)
WRITE (6,38)
GAS=(0.08205/XMW)*10.0**5/0.9869
WRITE (6,39)
WRITE (6,40) XMW,GAS,GAMMA
WRITE (6,41)
WRITE (6,42) TMELT,TBOIL,TCRIT,PCRIT
GO TO 44
43 WRITE (6,35)
WRITE (6,36)
WRITE (6,46)
WRITE (6,37) (HD(1,1),I=1,2),HD(1,2)
WRITE (6,38)
WRITE (6,50)
GAS=1545.33/XMW
WRITE (6,40) XMW,GAS,GAMMA
WRITE (6,51)
TMELT=TMELT*9.0/5.0-459.67
TBOIL=TBOIL*9.0/5.0-459.67
TCRIT=TCRIT*9.0/5.0-459.67

```

C2-22

```

PCMIT=PCRIT*14.7/10.0**5
WRITE (6,42) TMELT,TBOIL,TCRIT,PCMIT
44 RETURN
END

```

```

SUBROUTINE POUT2 (NK,OTEMP,OPRES,ORHOL,ORHOV,OSIGM,DXLAM,DXMUL,DXM
IUV,GAMMA,XMW,NBRIT,OTHCL,POINT,LSUPP)
DIMENSION OTEMP(8),OPRES(8),ORHOL(8),ORHOV(8),OSIGM(8),DXLAM(8)
DIMENSION DXMUL(8),DXMUV(8),DXNUL(8),DXNUV(8),RATIO(8),DXNL(8)
DIMENSION OH(8),SONIC(8),OSHF(8),OTHCL(8)
DIMENSION BTEMP(8),BPRES(8),BRHOL(8),BRHOV(8),BSIGM(8),DXLAM(8)
DIMENSION BXMUL(8),BXMUV(8),BXNUL(8),BXNUV(8),BXNL(8),BH(8)
DIMENSION BSONIC(8),BOSHF(8),BTHCL(8)
INTEGER POINT
66 FORMAT ('*')
67 FORMAT ('* TEMPERATURE - DEPEN
IDENT PROPERTIES*)
68 FORMAT ('** TEMPERATURE*)
70 FORMAT ('** VAPOR PRESSURE*)
72 FORMAT ('** LIQUID DENSITY*)
74 FORMAT ('** VAPOR DENSITY*)
76 FORMAT ('** SURFACE TENSION*)
78 FORMAT ('** LATENT HEAT*)
80 FORMAT ('** THERMAL CONDUCTIVITY OF LIQUID*)
82 FORMAT ('** DYNAMIC VISCOSITY OF LIQUID*)
84 FORMAT ('** KINEMATIC VISCOSITY OF LIQUID*)
86 FORMAT ('** DYNAMIC VISCOSITY OF VAPOR*)
90 FORMAT ('** KINEMATIC VISCOSITY OF VAPOR*)
92 FORMAT ('** RATIO OF KINEMATIC VISCOSITIES*)
95 FORMAT ('** WICKING HEIGHT FACTOR*)
97 FORMAT ('** LIQUID TRANSPORT FACTOR*)
99 FORMAT ('** SONIC HEAT FLUX*)
121 FORMAT ('** SONIC VELOCITY*)
69 FORMAT (17H (KELVIN) ,23X,8E10.1)
71 FORMAT (14H (N/M-M) ,26X,8E10.2)
73 FORMAT (15H (KG/M-M-M) ,25X,8E10.2)
75 FORMAT (15H (KG/M-M-M) ,25X,8E10.2)
77 FORMAT (11H (N/M) ,29X,8E10.2)
79 FORMAT (11H (W-S/KG) ,29X,8E10.2)
81 FORMAT (19H (W/M-K) ,21X,8E10.2)
83 FORMAT (16H (KG/M-S) ,24X,8E10.2)
85 FORMAT (17H (M-M/S) ,23X,8E10.2)
89 FORMAT (16H (KG/M-S) ,24X,8E10.2)
91 FORMAT (17H (M-M/S) ,23X,8E10.2)
94 FORMAT (20H (VAPOR/LIQUID) ,20X,8E10.2)
96 FORMAT (10H (M-M) ,30X,8E10.2)
98 FORMAT (14H (W/M-M) ,26X,8E10.2)
100 FORMAT (12H (W/M-M) ,28X,8E10.2)
119 FORMAT (18H (M/S) ,22X,8E10.2)
103 FORMAT (17H (FAHRENHEIT) ,23X,8E10.1)
104 FORMAT (13H (PSI) ,27X,8E10.2)
105 FORMAT (18H (LBM/FT-FT-FT) ,22X,8E10.2)
106 FORMAT (18H (LBM/FT-FT-FT) ,22X,8E10.2)
107 FORMAT (14H (LBF/FT) ,26X,8E10.2)
108 FORMAT (14H (BTU/LBM),29X,8E10.2)

```

```

109 FORMAT (19H (BTU/HR-FT-F) ,21X,8E10.2)
110 FORMAT (17H (LBM/FT-HR) ,23X,8E10.2)
111 FORMAT (17H (FT-FT/HR) ,23X,8E10.2)
112 FORMAT (18H (LBM/FT-HR) ,22X,8E10.2)
113 FORMAT (16H (FT-FT/HR) ,24X,8E10.2)
114 FORMAT (12H (FT-FT) ,28X,8E10.2)
115 FORMAT (18H (BTU/HR-FT-FT) ,22X,8E10.2)
120 FORMAT (19H (BTU/HR-FT-FT) ,21X,8E10.2)
116 FORMAT (18H (FT/HR) ,22X,8E10.2)
IF (LSUPP.GT.1) GO TO 117
IF (POINT.EQ.1) GO TO 11
IF (NK.EQ.1) GO TO 117
11 WRITE (6,66)
WRITE (6,67)
DO 65 I=1,NK
DXNUL(I)=DXMUL(I)/ORHOL(I)
DXNUV(I)=DXMUV(I)/ORHOV(I)
RATIO(I)=DXNUV(I)/DXNUL(I)
OSNL(I)=OSIGM(I)*DXLAM(I)*ORHOL(I)/DXMUL(I)
OH(I)=OSIGM(I)/(9.8*ORHOL(I))
SONIC(I)=((GAMMA*OTEMP(I))*1.8*1545.33*32.2/XMW)**0.5)**0.3048
USHF(I)=DXLAM(I)*ORHOV(I)*SONIC(I)/(2.0*(GAMMA+1.0))**0.5
65 CONTINUE
IF (NBRIT=0) 101,102,101
102 WRITE (6,68)
WRITE (6,69) (OTEMP(I),I=1,NK)
WRITE (6,70)
WRITE (6,71) (OPRES(I),I=1,NK)
WRITE (6,72)
WRITE (6,73) (ORHOL(I),I=1,NK)
WRITE (6,74)
WRITE (6,75) (ORHOV(I),I=1,NK)
WRITE (6,76)
WRITE (6,77) (OSIGM(I),I=1,NK)
WRITE (6,78)
WRITE (6,79) (DXLAM(I),I=1,NK)
WRITE (6,80)
WRITE (6,81) (OTHCL(I),I=1,NK)
WRITE (6,82)
WRITE (6,83) (DXMUL(I),I=1,NK)
WRITE (6,84)
WRITE (6,85) (DXNUL(I),I=1,NK)
WRITE (6,86)
WRITE (6,89) (DXMUV(I),I=1,NK)
WRITE (6,90)
WRITE (6,91) (DXNUV(I),I=1,NK)
WRITE (6,92)
WRITE (6,94) (RATIO(I),I=1,NK)
WRITE (6,95)
WRITE (6,96) (OH(I),I=1,NK)
WRITE (6,97)
WRITE (6,98) (OSNL(I),I=1,NK)
WRITE (6,99)
WRITE (6,100) (OSHF(I),I=1,NK)
WRITE (6,121)
WRITE (6,119) (SONIC(I),I=1,NK)
GO TO 117
101 DO 118 I=1,NK

```

```

BTEMP(I)=TEMP(I)*9.0/5.0-459.67
BPRES(I)=OPRES(I)*0.0001451
BRHOL(I)=ORHOL(I)*0.06243
BRHOV(I)=ORHOV(I)*0.06243
BTACL(I)=OTACL(I)*0.780
BSIGM(I)=OSIGM(I)*0.005708*12.0
BXLAM(I)=OXLAM(I)*0.0004302
BXMUL(I)=OXMUL(I)*2.205*1600.0/3.281
BXMUV(I)=OXMUV(I)*2.205*1600.0/3.281
BXNUL(I)=OXNUL(I)*1600.0*3.281**2
BXNUV(I)=OXNUV(I)*1600.0*3.281**2
BXNL(I)=OXNL(I)*3.4129/3.281**2
BH(I)=OH(I)*3.281**2
BSONI(I)=SONI(I)*3.281*1600.0
118 BUSHF(I)=OSHF(I)*3.4129/3.281**2
WRITE (6,68)
WRITE (6,103) (BTEMP(I),I=1,NK)
WRITE (6,70)
WRITE (6,104) (BPRES(I),I=1,NK)
WRITE (6,72)
WRITE (6,105) (BRHOL(I),I=1,NK)
WRITE (6,74)
WRITE (6,106) (BRHOV(I),I=1,NK)
WRITE (6,76)
WRITE (6,107) (BSIGM(I),I=1,NK)
WRITE (6,78)
WRITE (6,108) (BXLAM(I),I=1,NK)
WRITE (6,80)
WRITE (6,109) (BTACL(I),I=1,NK)
WRITE (6,82)
WRITE (6,110) (BXMUL(I),I=1,NK)
WRITE (6,84)
WRITE (6,111) (BXNUL(I),I=1,NK)
WRITE (6,86)
WRITE (6,112) (BXMUV(I),I=1,NK)
WRITE (6,90)
WRITE (6,113) (BXNUV(I),I=1,NK)
WRITE (6,92)
WRITE (6,94) (RATIC(I),I=1,NK)
WRITE (6,95)
WRITE (6,114) (BH(I),I=1,NK)
WRITE (6,97)
WRITE (6,115) (BXNL(I),I=1,NK)
WRITE (6,99)
WRITE (6,120) (BUSHF(I),I=1,NK)
WRITE (6,121)
WRITE (6,116) (BSONI(I),I=1,NK)
117 RETURN
END

```

C.2-24

```

SUBROUTINE POUT3 (TMI3,TMA4,NBRIT,UNITS,POINT,TEMP,T1,T2,LOUT)
INTEGER UNITS,POINT
10 FORMAT ('I')
43 FORMAT (//55H TEMPERATURE(S) EXCEEDS TABLE RANGE, THE RANGE IS FR
LOM,F8.1,6H(K) TO,F8.1,4H(K).)
12 FORMAT (//20H THE TEMPERATURE IS,F8.1,4H(K).)

```

```

LOUT=2
13 FORMAT (//31H THE TEMPERATURE RANGE IS FROM,F8.1,6H(K) TO,F8.1,4H
(K).)
4 FORMAT (//55H TEMPERATURE(S) EXCEEDS TABLE RANGE, THE RANGE IS FR
LOM,F8.1,6H(F) TO,F8.1,4H(F).)
24 FORMAT (//20H THE TEMPERATURE IS,F8.1,4H(F).)
15 FORMAT (//31H THE TEMPERATURE RANGE IS FROM,F8.1,6H(F) TO,F8.1,4H
(F).)
WRITE (6,10)
IF (NBRIT.FQ.1) GO TO 3
WRITE (6,43) TMI3,TMA4
IF (POINT.NE.1) GO TO 11
WRITE (6,12) TEMP
GO TO 22
11 WRITE (6,13) T1,T2
22 IF (UNITS.EQ.1) GO TO 62
RETURN
3 TMI3=TMI3*9.0/5.0-459.67
TMA4=TMA4*9.0/5.0-459.67
TEMP=TEMP*9.0/5.0-459.67
T1=T1*9.0/5.0-459.67
T2=T2*9.0/5.0-459.67
WRITE (6,4) TMI3,TMA4
IF (POINT.NE.1) GO TO 14
WRITE (6,24) TEMP
GO TO 62
14 WRITE (6,15) T1,T2
62 RETURN
END

```

```

SUBROUTINE HYDRO (LSUPP,LOUT,NBRIT,POINT,UNITS,ORHOL,ORHOV,OXLAM,OSIGM,
OXMUL,OXMUV,TEMP,OPRES,XMW,GAMMA)
DIMENSION XMUL(30),XMUV(30),HD(2,2),XLAMD(30),OXMUL(8),OXMUV(8)
DIMENSION XTEMP(30),PRESS(30),RHOV(30),RHOL(30),SIGMA(30)
DIMENSION OTACL(8),OXLAM(8),OTEMP(8),OPRES(8),ORHOL(8),ORHOV(8)
DIMENSION OSIGM(8),THECL(30)
INTEGER POINT,UNITS
15 FORMAT (//* NOTE INPUT TEMPERATURE RANGE HAS BEEN ADJUSTED*)
16 FORMAT ('I')
MM=9
IND=0
NBRIT=0
GAMMA=1.41
XMW=2.07
TCRIT=32.9
TMELT=13.81
TBOIL=20.27
PCRIT=107.06895*10.**3
DATA (HD(I,1),I=1,2),HD(1,2)/8HHYDROGEN,2HM2/
DATA (XTEMP(I),I=1,9)/14.0,15.0,17.0,19.0,21.0,23.0,25.0,27.0,29.0
/
DATA (PRESS(I),I=1,5)/ 7.40E+3,1.30E+4,3.46E+4,7.55E+4,1.36E+5,2.2
1E+5,3.27E+5,4.27E+5,6.10E+5/
DATA (RHOL(I),I=1,9)/ 7.44E+1,7.42E+1,7.36E+1,7.22E+1,7.02E+1,6.7
17E+1,6.41E+1,5.99E+1,5.53E+1/
DATA (RHOV(I),I=1,9)/1.52E-1,2.26E-1,4.90E-1,9.45E-1,1.67E+0,2.70E

```

REPRODUCIBILITY OF THIS ORIGINAL PAGE IS POOR

C2-25

```

1+0.4.08E+0.6.0JE+0.9.0ZE+0/
DATA (SIGMA(1),I=1,9)/ 2.94E-3,2.81E-3,2.49E-3,2.14E-3,1.77E-3,1.4
13E-3,1.06E-3,7.10E-4,3.20E-4/
DATA (XLAMD(1),I=1,9)/ 4.53E+5,4.52E+5,4.48E+5,4.43E+5,4.35E+5,4.2
13E+5,4.07E+5,3.82E+5,3.35E+5/
DATA (XMU(1),I=1,9)/ 2.34E-5,2.18E-5,1.78E-5,1.46E-5,1.25E-5,1.1
14E-5,1.07E-5,1.01E-5,9.30E-6/
DATA (XMUV(1),I=1,9)/ 7.00E-7,7.50E-7,8.60E-7,9.70E-7,1.04E-6,1.2
11E-6,1.34E-6,1.46E-6,1.60E-6/
DATA (THECL(1),I=1,9)/ 1.03E-1,1.06E-1,1.11E-1,1.15E-1,1.20E-1,1.2
15E-1,1.29E-1,1.34E-1,1.38E-1/
NIND=1
IF (LSUPP.GT.1) GO TO 12
READ (5,30) POINT,UNITS
30 FORMAT (I03)
12 IF (POINT-1) 31,32,31
32 IF (NBRT.EQ.1) GO TO 64
IF (LSUPP.GT.1) GO TO 64
READ (5,31) TEMP
33 FORMAT (BF10.4)
64 IF (TEMP.LT.XTEMP(1)) GO TO 34
IF (TEMP.GT.XTEMP(1)) GO TO 34
GO TO 11
31 READ (5,33) TMIN,TMAX,DT
IF (NBRT.NE.1) GO TO 5
TMIN=(TMIN+459.67)*5.0/9.0
TMAX=(TMAX+459.67)*5.0/9.0
DT=DT*5.0/9.0
5 IF (TMIN.GT.XTEMP(1)) GO TO 34
IF (TMAX.LT.XTEMP(1)) GO TO 34
IF (TMIN.GE.XTEMP(1)) GO TO 43
IND=1
TMIN=XTEMP(1)
43 IF (TMAX.LE.XTEMP(1)) GO TO 44
IND=1
TMAX=XTEMP(1)
44 TEMP=TMIN
11 CALL POUT(IND,XMW,TMELT,TROIL,TCRIT,TCRIT,NBRT,GAMMA,LSUPP)
IF (POINT.NE.1) GO TO 20
IF (TEMP.LT.XTEMP(1)) GO TO 63
IF (TEMP.GT.XTEMP(1)) GO TO 63
20 IF (POINT.EQ.1) GO TO 21
IF (TMIN.GT.XTEMP(1)) GO TO 10
IF (TMAX.LT.XTEMP(1)) GO TO 10
21 IF (IND.EQ.0) GO TO 14
WRITE (6,16)
WRITE (6,15)
14 IF (POINT-1) 45,46,45
46 DT=0.0
TMAX=TEMP
45 TEMP=TEMP-DT
99 DO 5/ K=1,8
TEMP=TEMP+DT
IF (K.NE.1) GO TO 88
IF (TEMP.GT.TMAX) GO TO 63
88 IF (TEMP.GT.TMAX) GO TO 61
N*=K
DO 68 I=NIND,MM

```

```

IF (XTEMP(1)-TEMP) 68,59,60
59 I1=1
OTFMP(K)=TEMP
UPRES(K)=PRESS(1)
ORHOL(K)=RHOL(1)
ORHOV(K)=RHOV(1)
USIGM(K)=SIGMA(1)
OXLAM(K)=XLAMD(1)
OXMUL(K)=XMUL(1)
OXMUV(K)=XMUV(1)
OTHCL(K)=THECL(1)
IF (POINT.EQ.1) GO TO 61
GO TO 57
60 IF (I.EQ.1) GO TO 59
I1=1
I1=I-1
OTEMP(K)=TEMP
UPRES(K)=EXP((ALOG(PRESS(1))-ALOG(PRESS(I0)))*TEMP+(XTEMP(1)-AL
IUG(PRESS(I0))-XTEMP(I0)*ALOG(PRESS(1)))/(XTEMP(1)-XTEMP(I0))
ORHOL(K)=RHOL(1)+(RHOL(1)-RHOL(I0))*(TEMP-XTEMP(1))/(XTEMP(1)-
IXTEMP(I0))
ORHOV(K)=EXP((ALOG(RHOV(1))-ALOG(RHOV(I0)))*TEMP+(XTEMP(1)-AL
IUG(RHOV(I0))-XTEMP(I0)*ALOG(RHOV(1)))/(XTEMP(1)-XTEMP(I0))
OTHCL(K)=THECL(1)+(THECL(1)-THECL(I0))*(TEMP-XTEMP(1))/(XTEMP(
1)-XTEMP(I0))
USIGM(K)=SIGMA(1)+(SIGMA(1)-SIGMA(I0))*(TEMP-XTEMP(1))/(XTEMP(
1)-XTEMP(I0))
OXLAM(K)=XLAMD(1)+(XLAMD(1)-XLAMD(I0))*(TEMP-XTEMP(1))/(XTEMP(
1)-XTEMP(I0))
OXMUL(K)=XMUL(1)+(XMUL(1)-XMUL(I0))*(TEMP-XTEMP(1))/(XTEMP(1)-
IXTEMP(I0))
OXMUV(K)=XMUV(1)+(XMUV(1)-XMUV(I0))*(TEMP-XTEMP(1))/(XTEMP(1)-
IXTEMP(I0))
IF (POINT.EQ.1) GO TO 61
GO TO 57
68 CONTINUE
57 CONTINUE
61 CALL POUT(IND,OTEMP,OPRES,ORHOL,ORHOV,OSIGM,OXLAM,OXMUL,OXMUV,GAM
MA,XMW,NBRT,OTHCL,POINT,LSUPP)
IF (POINT.EQ.1) GO TO 10
IF (TEMP.LE.TMAX) GO TO 99
10 IF (NBRT.NE.0) GO TO 62
NBRT=1
IF (UNITS.EQ.2) GO TO 12
GO TO 62
34 A1=XTEMP(1)
A2=XTEMP(1)
IF (POINT.EQ.1) GO TO 55
TEMP=0.0
GO TO 66
55 TMIN=0.0
TMAX=0.0
66 CALL POUT(A1,A2,NBRT,UNITS,POINT,TEMP,TMIN,TMAX,LOUT)
63 IF (UNITS.NE.2) GO TO 62
IF (NBRT.NE.0) GO TO 62
NHRT=1
IF (POINT.NE.1) GO TO 31
GO TO 64

```

A2 RETURN
END

SUBROUTINE NITRO (LSUPP,LOUT,NDRIT,PLINT,UNITS,DHMDL,DRHUV,DXLAM,U
LSIGM,UXMUL,ORHUV,TEMP,OPRES,KMW,GAMMA)
DIMENS (UN, XNUM(30), XHUV(10), MD(2,2), XLAMD(10), XNUM(8), ORHUV(1)
DIMENSION XTEMP(30), PRESS(30), RHUV(10), RHOL(30), SIGMA(30)
DIMENSION DTMCL(8), DXLAM(8), DTEMP(8), UPRI(18), DRHOL(8), DRHUV(8)
DIMENSION DSIGM(8), THECL(30)
INTEGER POINT,UNITS

16 FORMAT ('*')
15 FORMAT (///) NOTE INPUT TEMPERATURE RANGE HAS BEEN ADJUSTED*

MM=13
IND=0
NDRIT=0
GAMMA=1.404
KMW=28.02
TCRIT=125.96
TMELT=63.14
TBOIL=77.35
PCRIT=3.395*10.**6
DATA (MD(1,1),1=1,2),MD(1,2)/8/MH11,ROGEN,ZHNZ/
DATA (XTEMP(1),1=1,13)/65.0,70.0,75.0,80.0,85.0,90.0,95.0,100.0,10
15.0,110.0,115.0,120.0,125.0/
DATA (PRESS(1),1=1,13)/1.70E+4,3.82E+4,7.50E+4,1.32E+5,2.20E+5,3.5
16E+5,5.40E+5,7.83E+5,1.11E+6,1.52E+6,1.99E+6,2.58E+6,3.25E+6/
DATA (RHOL(1),1=1,13)/8.64E+2,8.45E+2,8.24E+2,8.02E+2,7.78E+2,7.52
1E+2,7.26E+2,6.94E+2,6.61E+2,6.24E+2,5.82E+2,5.26E+2,4.31E+2/
DATA (RHUV(1),1=1,13)/9.20E-1,1.83E+0,3.80E+0,5.82E+0,9.65E+0,1.52
1E+1,2.21E+1,3.10E+1,4.33E+1,5.90E+1,7.95E+1,1.13E+2,2.10E+2/
DATA (SIGMA(1),1=1,13)/1.17E-2,1.05E-2,9.30E-3,8.20E-3,7.16E-3,6.1
15E-3,5.13E-3,4.15E-3,3.20E-3,2.28E-3,1.40E-3,6.80E-4,1.20E-4/
DATA (XLAMD(1),1=1,13)/2.11E+5,2.06E+5,2.01E+5,1.95E+5,1.88E+5,1.8
10E+5,1.72E+5,1.62E+5,1.49E+5,1.35E+5,1.18E+5,9.30E+4,4.40E+4/
DATA (XNUM(1),1=1,3)/2.79E-4,2.19E-4,1.74E-4,1.41E-4,1.20E-4,1.04
1E-4,9.20E-5,8.40E-5,7.90E-5,7.50E-5,7.10E-5,6.80E-5,6.50E-5/
DATA (XHUV(1),1=1,13)/4.40E-6,4.90E-6,5.38E-6,5.81E-6,6.32E-6,6.70
1E-6,7.10E-6,7.55E-6,8.15E-6,8.00E-6,1.05E-5,1.21E-5,1.61E-5/
DATA (THECL(1),1=1,13)/1.66E-1,1.52E-1,1.44E-1,1.36E-1,1.27E-1,1.1
19E-1,1.10E-1,1.0E-1,9.20E-2,8.20E-2,7.10E-2,6.00E-2,4.80E-2/
NIND=1
IF (LSUPP.GT.1) GO TO 12
READ (5,30) POINT,UNITS

30 FORMAT (10I3)
12 * (POINT-1) 31,32,1
32 IF (NDRIT.EQ.1) GO TO 64
IF (LSUPP.GT.1) GO TO 64
READ (5,33) TAMP
33 FORMAT (8F10.4)
64 IF (TEMP.LT.XTEMP(1)) GO TO 34
IF (TEMP.GT.XTEMP(MM)) GO TO 34
GO TO 11
31 READ (5,33) TMIN,TMAX,DT
IF (NDRIT.NE.1) GO TO 5
TMIN=(TMIN+459.67)*5.0/9.0

TMAX=(TMAX+459.67)*5.0/9.0
DT=DT*5.0/9.0
5 IF (TMIN.GT.XTEMP(MM)) GO TO 34
IF (TMAX.LT.XTEMP(1)) GO TO 34
IF (TMIN.GE.XTEMP(1)) GO TO 43
IND=1
TMIN=XTEMP(1)
43 IF (TMAX.LE.XTEMP(MM)) GO TO 44
IND=1
TMAX=XTEMP(MM)

44 TEMP=TMIN
11 CALL POUT1(IND,KMW,TMELT,TBOIL,TCRIT,PCRIT,NDRIT,GAMMA,LSUPP)
IF (POINT.NE.1) GO TO 20
IF (TEMP.LT.XTEMP(1)) GO TO 63
IF (TEMP.GT.XTEMP(MM)) GO TO 63
20 IF (POINT.EQ.1) GO TO 21
IF (TMIN.GT.XTEMP(MM)) GO TO 10
IF (TMAX.LT.XTEMP(1)) GO TO 10
21 IF (IND.EQ.0) GO TO 14
WRITE (6,16)
WRITE (6,15)

14 IF (POINT-1) 45,46,45
46 DT=0.0
TMAX=TEMP
45 TEMP=TEMP-DT
99 DO 57 K=1,8
TEMP=TEMP+DT
IF (K.NE.1) GO TO 88
IF (TEMP.GT.TMAX) GO TO 63
88 IF (TEMP.GT.TMAX) GO TO 61
KK=K
DO 68 I=NIND,MM
IF (XTEMP(I)-TEMP) 68,59,60

59 II=I
DTEMP(K)=TEMP
UPRES(K)=PRESS(II)
ORHOL(K)=RHOL(II)
ORHUV(K)=RHUV(II)
USIGN(K)=SIGNA(II)
DXLAM(K)=XLAMD(II)
UXMUL(K)=XNUM(II)
ORHUV(K)=XHUV(II)
DTMCL(K)=THECL(II)
IF (POINT.EQ.1) GO TO 61
GO TO 57

60 IF (I.EQ.1) GO TO 59
II=I
J=J+1
DTEMP(K)=TEMP
OPRES(K)=EXP(((LOG(PRESS(II))-LOG(PRESS(10)))*(TEMP-XTEMP(II))
LOG(PRESS(10))-XTEMP(10))*ALOG(PRESS(II)))/(XTEMP(II)-XTEMP(10))
ORHOL(K)=RHOL(II)*(RHOL(II)-RHOL(10))*((TEMP-XTEMP(II))/(XTEMP(II)-
XTEMP(10))
ORHUV(K)=EXP(((LOG(RHUV(II))-LOG(RHUV(10)))*(TEMP-XTEMP(II))
LOG(RHUV(10))-XTEMP(10))*ALOG(RHUV(II)))/(XTEMP(II)-XTEMP(10))
DTMCL(K)=THECL(II)*(THECL(II)-THECL(10))*((TEMP-XTEMP(II))/(XTEMP(II)-
XTEMP(10))
USIGN(K)=SIGNA(II)*(SIGNA(II)-SIGNA(10))*((TEMP-XTEMP(II))/(XTEMP(II)-
XTEMP(10))

C2-26

C2-27

```

111-XTMP(IU)
OXLAM(K)=XLAMC(I)+(XLAMC(I)-XLAMC(IU))*(TEPP-XTMP(I))/XTMP(I)
111-XTMP(IU)
OXMUL(K)=XMUL(I)+(XMUL(I)-XMUL(IU))*(TEMP-XTMP(I))/(XTMP(I)-XTMP(IU))
OXMUV(K)=XMUV(I)+(XMUV(I)-XMUV(IU))*(TEMP-XTMP(I))/(XTMP(I)-XTMP(IU))
IF (POINT.EQ.1) GO TO 61
GO TO 57
68 CONTINUE
57 CONTINUE
61 CALL POUT2 (NK,OTEMP,OPRES,ORHOL,ORHOV,OSIGM,OXLAM,OXMUL,OXMUV,GAM
INA,XMW,NBRIT,OTHCL,POINT,LSUPP)
IF (POINT.EQ.1) GO TO 10
IF (TEMP.LE.TMAX) GO TO 99
10 IF (NBRIT.NE.0) GO TO 62
NBRIT=1
IF (UNITS.EQ.2) GO TO 12
GO TO 62
34 A1=XTMP(I)
A2=XTMP(M)
IF (POINT.EQ.1) GO TO 55
TEMP=0.0
GO TO 66
55 TMIN=0.0
TMAX=0.0
66 CALL POUT3 (A1,A2,NBRIT,UNITS,POINT,TEMP,TMIN,TMAX,LOUT)
63 IF (UNITS.NE.2) GO TO 62
IF (NBRIT.NE.0) GO TO 62
NBRIT=1
IF (POINT.NE.1) GO TO 31
GO TO 64
62 RETURN
END

```

```

SUBROUTINE OXYGE (LSUPP,LOUT,NBRIT,POINT,UNITS,ORHOL,ORHOV,OXLAM,OSIGM,OXMUL,OXMUV,TEMP,OPRES,XMW,GAMMA)
DIMENSION XMUL(30),XMUV(30),HD(2,2),XLAMC(30),OXMUL(8),OXMUV(8)
DIMENSION XTEMP(30),PRESS(30),RHUV(30),RHOL(30),SIGMA(30)
DIMENSION OTHCL(8),OXLAM(8),OTEMP(8),OPRES(8),ORHOL(8),ORHOV(8)
DIMENSION OSIGM(8),THECL(30)
INTEGER POINT,UNITS
16 FORMAT ('')
15 FORMAT (1//) NOTE INPUT TEMPERATURE RANGE HAS BEEN ADJUSTED*
MM=11
IND=0
NBRIT=0
GAMMA=1.401
XMW=31.9988
TCRIT=154.7
TMELT=94.8
TROI=90.2
DATA (HD(I,1),I=1,2),HD(1,2)/8HOXYGEN ,2HO2/
PCRIT=.507*10.**7
DATA(XTEMP(I),I=1,11)/60.0,70.0,80.0,90.0,100.0,110.0,120.0,130.0,

```

```

1140.0,145.0,150.0/
DATA (PRESS(I),I=1,11)/8.40E+2,6.60E+3,3.00E+4,9.40E+4,2.53E+5,5.4
10E+5,9.40E+5,1.71E+6,2.73E+6,3.45E+6,4.40E+6/
DATA (XMUL(I),I=1,11)/ 1.29E+3,1.24E+3,1.19E+3,1.14E+3,1.09E+3,1.0
13E+3,9.71E+2,9.00E+2,8.29E+2,7.67E+2,6.85E+2/
DATA (RHUV(I),I=1,11)/ 1.37E-1,1.19E-1,1.01E+0,4.10E+0,1.04E+1,2.3
10E+1,4.50E+1,8.00E+1,1.33E+2,1.80E+2,2.50E+2/
DATA (SIGMA(I),I=1,11)/2.06E-2,1.82E-2,1.58E-2,1.34E-2,1.10E-2,8.7
10E-3,6.40E-3,4.07E-3,2.13E-3,1.28E-3,5.70E-4/
DATA (XLAMC(I),I=1,11)/2.40E+5,2.32E+5,2.24E+5,2.15E+5,2.04E+5,1.9
11E+5,1.75E+5,1.54E+5,1.24E+5,1.01E+5,7.00E+4/
DATA (XMUL(I),I=1,11)/ 5.95E-4,3.48E-4,2.49E-4,1.89E-4,1.51E-4,1.2
18E-4,1.13E-4,1.05E-4,9.90E-5,9.60E-5,9.40E-5/
DATA (XMUV(I),I=1,11)/ 5.00E-6,5.52E-6,6.12E-6,6.78E-6,7.60E-6,8.5
10E-6,9.63E-6,1.12E-5,1.31E-5,1.46E-5,1.71E-5/
DATA (THECL(I),I=1,11)/1.83E-1,1.72E-1,1.61E-1,1.49E-1,1.37E-1,1.2
15E-1,1.14E-1,9.80E-2,8.10E-2,7.10E-2,5.80E-2/
NIND=1
IF (LSUPP.GT.1) GO TO 12
READ (5,30) POINT,UNITS
30 FORMAT (10I5)
12 IF (POINT=1) 31,32,31
32 IF (NBRIT.EC.1) GO TO 64
IF (LSUPP.GT.1) GO TO 64
READ (5,33) TEMP
33 FORMAT (8F10.4)
64 IF (TEMP.LT.XTMP(I)) GO TO 34
IF (TEMP.GT.XTMP(M)) GO TO 34
GO TO 11
31 READ (5,33) TMIN,TMAX,DT
IF (NBRIT.NE.1) GO TO 5
TMIN=(TMIN+459.67)*5.0/9.0
TMAX=(TMAX+459.67)*5.0/9.0
DT=DT*5.0/9.0
5 IF (TMIN.GT.XTMP(M)) GO TO 34
IF (TMAX.LT.XTMP(I)) GO TO 34
IF (TMIN.GE.XTMP(I)) GO TO 43
IND=1
TMIN=XTMP(I)
43 IF (TMAX.LE.XTMP(M)) GO TO 44
IND=1
TMAX=XTMP(M)
44 TEMP=TMIN
11 CALL POUT1(HD,XMW,TMELT,TROI,TCRIT,PCRIT,NBRIT,GAMMA,LSUPP)
IF (POINT.NE.1) GO TO 20
IF (TEMP.LT.XTMP(I)) GO TO 63
IF (TEMP.GT.XTMP(M)) GO TO 63
20 IF (POINT.EQ.1) GO TO 21
IF (TMIN.GT.XTMP(M)) GO TO 10
IF (TMAX.LT.XTMP(I)) GO TO 10
21 IF (IND.EQ.0) GO TO 14
WRITE (6,16)
WRITE (6,15)
14 IF (POINT=1) 45,46,45
46 DT=0.0
TMAX=TEMP
45 TEMP=TEMP-DT
44 DO 51 K=1,N

```

REPRODUCIBILITY OF THE
ORIGINAL PAGE IS POOR

CFP-28

```
IFMP=TEMP*DT
IF (K.NE.1) GO TO 88
IF (TEMP.GT.TMAX) GO TO 61
88 IF (TEMP.GT.TMAX) GO TO 61
NK=K
DO 68 I=NIND,MM
IF (XTEMP(I)-TEMP) 68,59,60
59 II=1
OTEMP(K)=TEMP
OPRES(K)=PRESS(II)
ORHOL(K)=RHOL(II)
ORHOV(K)=RHOV(II)
OSIGN(K)=SIGMA(II)
OXLAM(K)=XLAMD(II)
OXMUL(K)=XMUL(II)
OXMUV(K)=XMUV(II)
OTHCL(K)=THECL(II)
IF (POINT.EQ.1) GO TO 61
GO TO 57
60 IF (I.EQ.1) GO TO 59
II=1
IO=I-1
OTEMP(K)=TEMP
OPRES(K)=EXP((ALOG(PRESS(II))-ALOG(PRESS(IO))*TEMP+(XTEMP(II)*ALOG(PRESS(II))-XTEMP(IO)*ALOG(PRESS(II)))/(XTEMP(II)-XTEMP(IO)))
ORHOL(K)=RHOL(II)+(RHOL(II)-RHOL(IO))*(TEMP-XTEMP(II))/(XTEMP(II)-XTEMP(IO))
ORHOV(K)=RHOV(II)+(RHOV(II)-RHOV(IO))*(TEMP-XTEMP(II))/(XTEMP(II)-XTEMP(IO))
OTHCL(K)=THECL(II)+(THECL(II)-THECL(IO))*(TEMP-XTEMP(II))/(XTEMP(II)-XTEMP(IO))
OSIGN(K)=SIGMA(II)+(SIGMA(II)-SIGMA(IO))*(TEMP-XTEMP(II))/(XTEMP(II)-XTEMP(IO))
OXLAM(K)=XLAMD(II)+(XLAMD(II)-XLAMD(IO))*(TEMP-XTEMP(II))/(XTEMP(II)-XTEMP(IO))
OXMUL(K)=XMUL(II)+(XMUL(II)-XMUL(IO))*(TEMP-XTEMP(II))/(XTEMP(II)-XTEMP(IO))
OXMUV(K)=XMUV(II)+(XMUV(II)-XMUV(IO))*(TEMP-XTEMP(II))/(XTEMP(II)-XTEMP(IO))
IF (POINT.EQ.1) GO TO 61
GO TO 57
68 CONTINUE
57 CONTINUE
61 CALL POUT2 (NK,OTEMP,OPRES,ORHOL,ORHOV,OSIGN,OXLAM,OXMUL,OXMUV,GAMMA,XMW,NBRIT,OTHCL,POINT,LSUPP)
IF (POINT.EQ.1) GO TO 10
IF (TEMP.LE.TMAX) GO TO 99
10 IF (NBRIT.NE.0) GO TO 62
NBRIT=1
IF (POINT.NE.1) GO TO 12
GO TO 62
34 A1=XTEMP(1)
A2=XTEMP(MM)
IF (POINT.EQ.1) GO TO 55
TEMP=0.0
GO TO 55
55 TMIN=0.0
TMAX=0.0
```

```
60 CALL POUT3 (A1,A2,NBRIT,UNITS,POINT,TEMP,TMIN,TMAX,LOUT)
61 IF (UNITS.NE.2) GO TO 62
IF (NBRIT.NE.0) GO TO 62
NBRIT=1
IF (POINT.NE.1) GO TO 31
GO TO 64
62 RETURN
END
```

```
SUBROUTINE WATER (LSUPP,LOUT,NBRIT,POINT,UNITS,ORHOL,ORHOV,OXLAM,OSIGN,OXMUL,OXMUV,TEMP,OPRES,XMW,GAMMA)
DIMENSION XTEMP(30),PRESS(30),RHOV(30),RHOL(30),SIGMA(30)
DIMENSION OTHCL(8),OXLAM(8),OTEMP(8),OPRES(8),ORHOL(8),ORHOV(8)
DIMENSION OSIGN(8),THECL(30)
INTEGER POINT,UNITS
16 FORMAT ('**')
15 FORMAT ('** NOTE INPUT TEMPERATURE RANGE HAS BEEN ADJUSTED**')
MM=12
IND=0
NBRIT=0
GAMMA=1.33
XMW=18.0
TCRIT=647.0
TMELT=273.16
TB0IL=373.16
PCRIT=218.167*1052.099.0
DATA (MDI(1),I=1,7),MDI(2),BHWATER ,3HM20/
DATA (XTEMP(I),I=1,12)/275.0,300.0,325.0,350.0,375.0,400.0,425.0,450.0,475.0,500.0,525.0,550.0/
DATA (PRESS(I),I=1,12)/7.0E+2,3.5E+3,1.3E+4,4.2E+4,1.0E+5,2.4E+5,4.1E+5,8.5E+5,1.5E+6,2.6E+6,4.0E+6,6.0E+6/
DATA (RHOL(I),I=1,12)/1.0E+3,9.95E+2,9.85E+2,9.7E+2,9.6E+2,9.4E+2,9.15E+2,8.9E+2,8.6E+2,8.3E+2,8.0E+2,7.5E+2/
DATA (RHOV(I),I=1,12)/5.5E+2,2.5E+2,9.0E+2,2.5E+1,6.0E-1,1.3,2.5,4,1.6,8.0,1.3E+1,2.2E+1,3.4E+1/
DATA (SIGMA(I),I=1,12)/7.5E-2,7.1E-2,6.7E-2,6.28E-2,5.8E-2,5.35E-02,1.4,85E-2,4.3E-2,3.8E-2,3.25E-2,2.7E-2,2.2E-2/
DATA (XLAMD(I),I=1,12)/2.5E+6,2.44E+6,2.37E+6,2.31E+6,2.24E+6,2.18E+6,2.1E+6,2.01E+6,1.93E+6,1.82E+6,1.7E+6,1.55E+6/
DATA (XMUL(I),I=1,12)/1.6E-3,8.3E-4,5.2E-4,3.7E-4,2.8E-4,2.1E-4,1.18E-4,1.5E-4,1.3E-4,1.2E-4,1.0E-4,9.0E-5/
DATA (XMUV(I),I=1,12)/9.6E-6,1.02E-5,1.12E-5,1.2E-5,1.32E-5,1.44E-5,1.58E-5,1.74E-5,1.9E-5,2.12E-5,2.38E-5,2.72E-5/
DATA (THECL(I),I=1,12)/5.8E-1,6.1E-1,6.4E-1,6.7E-1,6.82E-1,6.85E-1,16.8E-1,6.7E-1,6.56E-1,6.35E-1,6.12E-1,5.76E-1/
NIND=1
IF (LSUPP.GT.1) GO TO 12
READ (5,30) POINT,UNITS
30 FORMAT (10I3)
12 IF (POINT=1) 31,32,31
32 IF (NBRIT.EQ.1) GO TO 64
IF (LSUPP.GT.1) GO TO 64
READ (5,31) TEMP
33 FORMAT (8F10.4)
```



```

64 IF (TEMP.LT.XTEMP(1)) GO TO 34
   IF (TEMP.GT.XTEMP(MM)) GO TO 34
   GO TO 11
31 READ (5,33) TMIN,TMAX,DT
   IF (NBRIT.NE.1) GO TO 5
   TMIN=(TMIN+459.67)*5.0/9.0
   TMAX=(TMAX+459.67)*5.0/9.0
   DT=DT*5.0/9.0
   5 IF (TMIN.GT.XTEMP(MM)) GO TO 34
   IF (TMAX.LT.XTEMP(1)) GO TO 34
   IF (TMIN.GE.XTEMP(1)) GO TO 43
   IND=1
   TMIN=XTEMP(1)
43 IF (TMAX.LE.XTEMP(MM)) GO TO 44
   IND=1
   TMAX=XTEMP(MM)
44 TEMP=TMIN
11 CALL POUT1(IND,XMW,THMELT,TBOIL,TCRIT,PCRIT,NBRIT,GAMMA,LSUPP)
   IF (POINT.NE.1) GO TO 20
   IF (TEMP.LT.XTEMP(1)) GO TO 63
   IF (TEMP.GT.XTEMP(MM)) GO TO 63
20 IF (POINT.EQ.1) GO TO 21
   IF (TMIN.GT.XTEMP(MM)) GO TO 10
   IF (TMAX.LT.XTEMP(1)) GO TO 10
21 IF (IND.EQ.0) GO TO 14
   WRITE (6,16)
   WRITE (6,15)
14 IF (POINT=1) 45,46,45
46 DT=0.0
   TMAX=TEMP
45 TEMP=TEMP-DT
99 DO 57 K=1,8
   TEMP=TEMP+DT
   IF (K.NE.1) GO TO 88
   IF (TEMP.GT.TMAX) GO TO 63
88 IF (TEMP.GT.TMAX) GO TO 61
   NK=K
   DO 60 I=NIND,MM
   IF (XTEMP(I)-TEMP) 68,59,60
59 II=1
   OTEMP(K)=TEMP
   OPRES(K)=PRESS(II)
   ORHOL(K)=RHOL(II)
   ORHOV(K)=RHOV(II)
   OSIGM(K)=SIGMA(II)
   OXLAM(K)=XLAMD(II)
   OXMUL(K)=XMUL(II)
   OXMUV(K)=XMUV(II)
   OTHCL(K)=THECL(II)
   IF (POINT.EQ.1) GO TO 61
   GO TO 57
60 IF (II.EQ.1) GO TO 59
   II=1
   IO=1-1
   OTEMP(K)=TEMP
   OPRES(K)=EXP((ALOG(PRESS(II))-ALOG(PRESS(IO)))*TEMP+(XTEMP(II)*ALOG(PRESS(IO))-XTEMP(IO)*ALOG(PRESS(II)))/(XTEMP(II)-XTEMP(IO)))
   ORHOL(K)=RHOL(II)+(RHOL(II)-RHOL(IO))*(TEMP-XTEMP(II))/(XTEMP(II)-

```

```

XTEMP(IO))
   ORHOV(K)=EXP((ALOG(RHOV(II))-ALOG(RHOV(IO)))*TEMP+(XTEMP(II)*ALOG(RHOV(IO))-XTEMP(IO)*ALOG(RHOV(II)))/(XTEMP(II)-XTEMP(IO)))
   OTHCL(K)=THECL(II)+(THECL(II)-THECL(IO))*(TEMP-XTEMP(II))/(XTEMP(II)-XTEMP(IO))
   OSIGM(K)=SIGMA(II)+(SIGMA(II)-SIGMA(IO))*(TEMP-XTEMP(II))/(XTEMP(II)-XTEMP(IO))
   OXLAM(K)=XLAMD(II)+(XLAMD(II)-XLAMD(IO))*(TEMP-XTEMP(II))/(XTEMP(II)-XTEMP(IO))
   OXMUL(K)=XMUL(II)+(XMUL(II)-XMUL(IO))*(TEMP-XTEMP(II))/(XTEMP(II)-XTEMP(IO))
   OXMUV(K)=XMUV(II)+(XMUV(II)-XMUV(IO))*(TEMP-XTEMP(II))/(XTEMP(II)-XTEMP(IO))
   IF (POINT.EQ.1) GO TO 61
   GO TO 57
68 CONTINUE
57 CONTINUE
61 CALL POUT2 (NK,OTEMP,OPRES,ORHOI,ORHOV,OSIGM,OXLAM,OXMUL,OXMUV,GAMMA,XMW,NBRIT,OTHCL,POINT,LSUPP)
   IF (POINT.EQ.1) GO TO 10
   IF (TEMP.LE.TMAX) GO TO 99
10 IF (NBRIT.NE.0) GO TO 62
   NBRIT=1
   IF (UNITS.EQ.2) GO TO 12
   GO TO 62
34 A1=XTEMP(1)
   A2=XTEMP(MM)
   IF (POINT.EQ.1) GO TO 55
   TEMP=0.0
   GO TO 66
55 TMIN=0.0
   TMAX=0.0
66 CALL POUT3 (A1,A2,NBRIT,UNITS,POINT,TEMP,TMIN,TMAX,LOUT)
63 IF (UNITS.NE.2) GO TO 62
   IF (NBRIT.NE.0) GO TO 62
   NBRIT=1
   IF (POINT.NE.1) GO TO 31
   GO TO 64
62 RETURN
   END

```

```

SUBROUTINE AMMON (LSUPP,LOUT,NBRIT,POINT,UNITS,ORHOL,ORHOV,OXLAM,O
1SIGM,OXMUL,OXMUV,TEMP,OPRES,XMW,GAMMA)
DIMENSION XMUL(30),XMUV(30),HD(2,2),XLAMD(30),OXMUL(8),OXMUV(8)
DIMENSION XTEMP(30),PRESS(30),RHOV(30),RHOL(30),SIGMA(30)
DIMENSION OTHCL(8),OXLAM(8),OTEMP(8),OPRES(8),ORHOL(8),ORHOV(8)
DIMENSION OSIGM(8),THECL(30)
INTEGER POINT,UNITS
16 FURMAT ('1')
15 FURMAT ('//') NOTE INPUT TEMPERATURE RANGE HAS BEEN ADJUSTED*
MM=24
IND=0
NBRIT=0
GAMMA=1.31
XMW=17.0

```

C2-30

```
TCM=40.3
TMELT=195.0
TRUILL=239.7
PCMCIT=111.3*1.01325*10.0**5
DATA (HDI(1,1),1=1,2),HDI(1,2)/7HAMMONIA,3HNM3/
DATA (XTEMP(1),1=1,24/200.0,210.0,220.0,230.0,240.0,250.0,260.0,
1270.0,280.0,290.0,300.0,310.0,320.0,330.0,340.0,350.0,360.0,370.0,375.0
2,380.0,385.0,390.0,395.0,400.0,405.0/
DATA (PRESS(1),1=1,24/8.99E+3,1.82E+4,3.46E+4,6.16E+4,1.02E+5,
11.67E+5,2.544E+5,3.84E+5,5.56E+5,7.88E+5,1.07E+6,1.41E+6,1.84E+6,
23.01E+6,4.75E+6,5.25E+6,5.86E+6,6.46E+6,7.07E+6,7.88E+6,8.69E+6,
39.19E+6,1.00E+7,1.02E+7/
DATA (RHOL(1),1=1,24/7.30E+2,7.16E+2,7.05E+2,6.93E+2,6.81E+2,6.69E+2,
6.56E+2,6.43E+2,6.30E+2,6.15E+2,6.01E+2,5.85E+2,5.69E+2,5.52E+2,
22.4.89E+2,4.77E+2,4.65E+2,4.50E+2,4.35E+2,4.17E+2,3.98E+2,3.75E+2,
33.40E+2,2.87E+2/
DATA (RHOF(1),1=1,24/8.90E-2,1.40E-1,3.20E-1,5.60E-1,9.00E-1,1.42E+0,
2.10E+0,3.05E+0,4.32E+0,6.08E+0,8.30E+0,1.11E+1,1.48E+1,2.43E+1,
21.4.10E+1,4.60E+1,5.20E+1,5.80E+1,6.60E+1,7.40E+1,8.80E+1,1.03E+2,
31.30E+2,2.30E+2/
DATA (SIGMA(1),1=1,24/4.38E-2,4.12E-2,3.86E-2,3.62E-2,3.36E-2,3.12E-2,
2.88E-2,2.63E-2,2.42E-2,2.20E-2,1.98E-2,1.75E-2,1.54E-2,1.12E-2,
2.2,7.49E-3,6.50E-3,5.68E-3,4.80E-3,3.98E-3,3.13E-3,2.28E-3,1.50E-3,
3,0.70E-3,0.00E+0/
DATA (XLAMD(1),1=1,24/1.48E+6,1.45E+6,1.43E+6,1.40E+6,1.37E+6,1.34E+6,
1.31E+6,1.27E+6,1.24E+6,1.20E+6,1.16E+6,1.11E+6,1.07E+6,9.60E+5,
8.20E+5,7.80E+5,7.37E+5,6.90E+5,6.34E+5,5.80E+5,5.13E+5,4.30E+5,
3,3.1E+5,1.30E+5/
DATA (XMUL(1),1=1,24/4.32E-4,3.60E-4,3.15E-4,2.88E-4,2.68E-4,2.56E-4,
2.50E-4,2.42E-4,2.34E-4,2.24E-4,2.14E-4,2.02E-4,1.90E-4,1.62E-4,
24.1.34E-4,1.25E-4,1.16E-4,1.08E-4,9.88E-5,9.75E-5,7.50E-5,6.25E-5,
34.88E-5,3.00E-5/
DATA (XMUV(1),1=1,24/6.78E-6,7.19E-6,7.52E-6,7.94E-6,8.35E-6,8.76E-6,
9.18E-6,9.59E-6,1.00E-5,1.05E-5,1.10E-5,1.15E-5,1.20E-5,1.32E-5,
25.1.46E-5,1.50E-5,1.55E-5,1.59E-5,1.65E-5,1.71E-5,1.78E-5,1.88E-5,
32.00E-5,2.30E-5/
DATA (THECL(1),1=1,24/5.31E-1,5.40E-1,5.45E-1,5.48E-1,5.48E-1,5.47E-1,
5.45E-1,5.41E-1,5.35E-1,5.25E-1,5.12E-1,4.97E-1,4.81E-1,4.46E-1,
2-1,4.07E-1,3.98E-1,3.89E-1,3.79E-1,3.70E-1,3.61E-1,3.51E-1,3.32E-1,
3,3.23E-1,3.14E-1/
NIND=1
IF (LSUPP.GT.1) GO TO 12
READ (5,30) POINT,UNITS
30 FORMAT (I0I3)
12 IF (POINT-1) 31,32,31
32 IF (NBRT.EQ.1) GO TO 64
IF (LSUPP.GT.1) GO TO 64
READ (5,33) TEMP
33 FORMAT (8F10.4)
64 IF (TEMP.LT.XTEMP(1)) GO TO 34
IF (TEMP.GT.XTEMP(MM)) GO TO 34
GO TO 11
31 READ (5,33) TMIN,TMAX,DT
IF (NBRT.NE.1) GO TO 5
TMIN=(TMIN+459.67)*5.0/9.0
TMAX=(TMAX+459.67)*5.0/9.0
DT=DT*5.0/9.0
5 IF (TMIN.GT.XTEMP(MM)) GO TO 34
```

```
IF (TMAX.LT.XTEMP(1)) GO TO 34
IF (TMIN.GT.XTEMP(1)) GO TO 43
IND=1
TMIN=XTEMP(1)
43 IF (TMAX.LT.XTEMP(MM)) GO TO 44
IND=1
TMAX=XTEMP(MM)
44 TEMP=TMIN
11 CALL POUT(1,HDI,XMW,TMELT,TBOIL,TCRIT,PCRT,NBRIT,GAMMA,LSUPP)
IF (POINT.NE.1) GO TO 20
IF (TEMP.LT.XTEMP(1)) GO TO 63
IF (TEMP.GT.XTEMP(MM)) GO TO 63
20 IF (POINT.EQ.1) GO TO 21
IF (TMIN.GT.XTEMP(MM)) GO TO 10
IF (TMAX.LT.XTEMP(1)) GO TO 10
21 IF (IND.EQ.0) GO TO 14
WRITE (6,16)
WRITE (6,15)
14 IF (POINT-1) 45,46,45
46 DT=0.0
TMAX=TEMP
45 TEMP=TEMP-DT
99 'O 57 K=1.8
TEMP=TEMP+DT
IF (K.NE.1) GO TO 88
IF (TEMP.GT.TMAX) GO TO 63
88 IF (TEMP.GT.TMAX) GO TO 61
N*K=N
DO 68 I=NIND,MM
IF (XTEMP(1)-TEMP) 68,59,60
59 I=1
UTEMP(K)=TEMP
UPRES(K)=PRESS(1)
URHOL(K)=RHOL(1)
URHOV(K)=RHOV(1)
USIGM(K)=SIGMA(1)
UXLAM(K)=XLAMD(1)
UXMUL(K)=XMUL(1)
UXMUV(K)=XMUV(1)
UTHCL(K)=THECL(1)
IF (POINT.EQ.1) GO TO 61
GO TO 57
60 IF (I.EQ.1) GO TO 59
I=1
IO=1-1
UTEMP(K)=TEMP
OPRES(K)=EXP((ALOG(PRESS(1))-ALOG(PRESS(IO)))*TEMP+(XTEMP(1))*ALOG(PRESS(IO))-XTEMP(IO)*ALOG(PRESS(1)))/(XTEMP(1)-XTEMP(IO))
URHOL(K)=RHOL(1)+(RHOL(1)-RHOL(IO))*(TEMP-XTEMP(1))/(XTEMP(1)-XTEMP(IO))
ORHOV(K)=EXP((ALOG(RHOV(1))-ALOG(RHOV(IO)))*TEMP+(XTEMP(1))*ALOG(RHOV(IO))-XTEMP(IO)*ALOG(RHOV(1)))/(XTEMP(1)-XTEMP(IO))
UTHCL(K)=THECL(1)+(THECL(1)-THECL(IO))*(TEMP-XTEMP(1))/(XTEMP(1)-XTEMP(IO))
USIGM(K)=SIGMA(1)+(SIGMA(1)-SIGMA(IO))*(TEMP-XTEMP(1))/(XTEMP(1)-XTEMP(IO))
UXLAM(K)=XLAMD(1)+(XLAMD(1)-XLAMD(IO))*(TEMP-XTEMP(1))/(XTEMP(1)-XTEMP(IO))
```

```

    UXMUL(K)=XMUL(11)+XMUL(11)-XMUL(10)*(TEMP-XTEMP(11))/(XTMP(11)-
    XTEMP(10))
    CXMUV(K)=XMOV(11)+XMOV(11)-XMOV(10)*(TEMP-XTEMP(11))/(XTEMP(11)-
    XTEMP(10))
    IF (POINT.EQ.1) GO TO 61
    GO TO 57
68 CONTINUE
57 CONTINUE
61 CALL POUT2 (NK,OTEMP,OPRES,ORHOL,ORHOV,OSIGN,OXLAM,UXMUL,UXM
    IUV,GAMMA,XMW,NBRIT,OTHCL,POINT,LSUPP)
    IF (POINT.EQ.1) GO TO 10
    IF (TEMP.LE.TMAX) GO TO 99
    IF (NBRIT.NE.0) GO TO 62
    NBRIT=1
    IF (UNITS.EQ.2) GO TO 12
    GO TO 62
34 A1=XTEMP(1)
    A2=XTEMP(MM)
    IF (POINT.EQ.1) GO TO 55
    TEMP=0.0
    GO TO 66
55 TMIN=0.0
    TMAX=0.0
66 CALL POUT3 (A1,A2,NBRIT,UNITS,POINT,TEMP,TMIN,TMAX,LOUT)
63 IF (UNITS.NE.2) GO TO 62
    IF (NBRIT.NE.0) GO TO 62
    NBRIT=1
    IF (POINT.NE.1) GO TO 31
    GO TO 64
62 RETURN
    END

```

```

SUBROUTINE METHA (LSUPP,LOUT,NBRIT,POINT,UNITS,ORHOL,ORHOV,OXLAM,0
    ISIGN,OXMUL,OXMUV,TEMP,OPRES,XMW,GAMMA)
    DIMENSION XMUL(30),XMOV(30),HD(2,2),XLAMD(30),OXMUL(8),OXMUV(8)
    DIMENSION XTEMP(30),PRESS(30),RHOV(30),RHOL(30),SIGMA(30)
    DIMENSION OTHCL(8),OXLAM(8),OTEMP(8),OPRES(8),ORHOL(8),ORHOV(8)
    DIMENSION OSIGN(8),THECL(30)
    INTEGER POINT,UNITS

```

```

16 FORMAT ('1')
15 FORMAT ('/' NOTE INPUT TEMPERATURE RANGE HAS BEEN ADJUSTED')
    MM=21
    IND=0
    NBRIT=0
    GAMMA=1.25
    XMW=32.04
    TCRIT=513.1
    TMELT=175.3
    TBOIL=337.8
    PCRIT=1156.9*6.895*10.**3
    DATA (HD(1,1),1=1,2),HD(1,2)/8METHANOL,5HCH3OH/
    DATA (XTEMP(1),1=1,21)/290.0,260.0,270.0,280.0,290.0,300.0,320.0,
    340.0,360.0,380.0,400.0,420.0,440.0,450.0,460.0,470.0,480.0,485.0,
    2490.0,495.0,500.0/
    DATA (PRESS(1),1=1,21)/7.70E+2,1.57E+3,2.92E+3,5.15E+3,8.71E+3,1.4
    17E+4,4.25E+4,1.03E+5,2.23E+5,4.56E+5,7.58E+5,1.24E+6,2.02E+6,2.51E

```

```

744,3.09E+6,3.77E+6,4.56E+6,5.01E+6,5.49E+6,5.98E+6,6.53E+6/
    DATA (XUL(1),1=1,21)/8.33E+2,8.25E+2,8.18E+2,8.10E+2,8.02E+2,7.94
    1E+2,7.75E+2,7.54E+2,7.30E+2,7.06E+2,6.79E+2,6.50E+2,6.17E+2,6.00E+
    2/2,5.47E+2,5.57E+2,5.32E+2,5.17E+2,5.00E+2,4.80E+2,4.56E+2/
    DATA (HOV(1),1=1,21)/1.24E-2,2.10E-2,3.90E-2,7.10E-2,1.26E-1,2.60
    1E-1,5.00E-1,1.42E+0,2.80E+0,5.10E+0,8.40E+0,1.43E+1,2.70E+1,2.98E+
    2/1,3.74E+1,4.65E+1,5.82E+1,6.60E+1,7.58E+1,8.90E+1,1.07E+2/
    DATA (SIGMA(1),1=1,21)/2.70E-2,2.60E-2,2.50E-2,2.39E-2,2.29E-2,2.1
    19E-2,1.98E-2,1.78E-2,1.57E-2,1.37E-2,1.16E-2,9.60E-3,7.50E-3,6.50E
    2-3,5.50E-3,4.50E-3,3.40E-3,2.90E-3,2.40E-3,1.90E-3,1.40E-3/
    DATA (XLAMD(1),1=1,21)/1.21E+6,1.20E+6,1.20E+6,1.19E+6,1.18E+6,1.1
    17E+6,1.14E+6,1.10E+6,1.06E+6,1.00E+6,9.35E+5,8.62E+5,7.80E+5,7.32E
    2+5,6.89E+5,5.22E+5,6.06E+5,5.17E+5,4.76E+5,4.28E+5,3.68E+5/
    DATA (XMUL(1),1=1,21)/1.19E-3,9.90E-4,8.40E-4,7.15E-4,6.10E-4,5.30
    1E-4,4.10E-4,3.40E-4,2.52E-4,2.06E-4,1.68E-4,1.37E-4,1.11E-4,1.01E-
    4,9.00E-5,7.90E-5,6.85E-5,6.45E-5,6.00E-5,5.60E-5,5.05E-5/
    DATA (XMOV(1),1=1,21)/8.09E-6,8.40E-6,8.71E-6,9.03E-6,9.37E-6,9.69
    1E-6,1.03E-5,1.10E-5,1.16E-5,1.23E-5,1.29E-5,1.36E-5,1.43E-5,1.47E-
    25,1.51E-5,1.55E-5,1.59E-5,1.62E-5,1.64E-5,1.67E-5,1.69E-5/
    DATA (THECL(1),1=1,21)/2.07E-1,2.06E-1,2.05E-1,2.05E-1,2.04E-1,2.0
    13E-1,2.02E-1,2.00E-1,1.99E-1,1.98E-1,1.96E-1,1.95E-1,1.93E-1,1.93E
    2-1,1.92E-1,1.91E-1,1.90E-1,1.90E-1,1.90E-1,1.89E-1,1.89E-1/
    NIND=1
    IF (LSUPP.GT.1) GO TO 12
    READ (5,30) POINT,UNITS
30 FORMAT (10I3)
    12 IF (POINT=1) 31,32,31
    32 IF (NBRIT.EQ.1) GO TO 64
    IF (LSUPP.GT.1) GO TO 64
    READ (5,33) TEMP
33 FORMAT (8F10.4)
    64 IF (TEMP.LT.XTEMP(1)) GO TO 34
    IF (TEMP.GT.XTEMP(MM)) GO TO 34
    GO TO 11
31 READ (5,33) TMIN,TMAX,DT
    IF (NBRIT.NE.1) GO TO 5
    TMIN=(TMIN+459.67)*5.0/9.0
    TMAX=(TMAX+459.67)*5.0/9.0
    DT=DT*5.0/9.0
    5 IF (TMIN.GT.XTEMP(MM)) GO TO 34
    IF (TMAX.LT.XTEMP(1)) GO TO 34
    IF (TMIN.GE.XTEMP(1)) GO TO 43
    IND=1
    TMIN=XTEMP(1)
    43 IF (TMAX.LE.XTEMP(MM)) GO TO 44
    IND=1
    TMAX=XTEMP(MM)
    44 TEMP=TMIN
    11 CALL POUT1 (HD,XMW,THELT,TBOIL,TCRIT,PCRIT,NBRIT,GAMMA,LSUPP)
    IF (POINT.NE.1) GO TO 20
    IF (TEMP.LT.XTEMP(1)) GO TO 63
    IF (TEMP.GT.XTEMP(MM)) GO TO 63
    20 IF (POINT.EQ.1) GO TO 21
    IF (TMIN.GT.XTEMP(MM)) GO TO 10
    IF (TMAX.LT.XTEMP(1)) GO TO 10
    21 IF (IND.EQ.0) GO TO 14
    WRITE (6,16)
    WRITE (6,15)

```

```

14 IF (POINT-1) 45,46,45
46 DT=0.0
  TMAX=TEMP
45 TEMP=TEMP-DT
99 DO 57 K=1,8
  TEMP=TEMP+DT
  IF (K.NE.1) GO TO 88
  IF (TEMP.GT.TMAX) GO TO 63
88 IF (TEMP.GT.TMAX) GO TO 61
  NK=K
  DO 68 I=NIND,PM
  IF (XTEMP(I)-TEMP) 68,59,60
59 II=I
  OTEMP(K)=TEMP
  UPRES(K)=PRESS(II)
  ORHOL(K)=RHOL(II)
  ORHOV(K)=RHOV(II)
  USIGM(K)=SIGMA(II)
  OXLAM(K)=XLAND(II)
  OXMUL(K)=XMUL(II)
  OXMUV(K)=XMUV(II)
  OTHCL(K)=THECL(II)
  IF (POINT.EQ.1) GO TO 61
  GO TO 57
60 IF (I.EQ.1) GO TO 59
  II=I
  IO=I-1
  OTEMP(K)=TEMP
  OPRES(K)=EXP((ALOG(PRESS(II))-ALOG(PRESS(IO)))*TEMP+(XTEMP(II)*AL
  LOG(PRESS(IO)-XTEMP(IO))*ALOG(PRESS(II)))/(XTEMP(II)-XTEMP(IO))
  ORHOL(K)=RHOL(II)+(RHOL(IO)-RHOL(IO))*(TEMP-XTEMP(II))/(XTEMP(II)-
  XTEMP(IO))
  ORHOV(K)=EXP((ALOG(RHOV(II))-ALOG(RHOV(IO)))*TEMP+(XTEMP(II)*AL
  LOG(RHOV(IO)-XTEMP(IO))*ALOG(RHOV(II)))/(XTEMP(II)-XTEMP(IO))
  OTHCL(K)=THECL(II)+(THECL(IO)-THECL(IO))*(TEMP-XTEMP(II))/(XTEMP(II)
  -XTEMP(IO))
  OSIGM(K)=SIGMA(II)+(SIGMA(II)-SIGMA(IO))*(TEMP-XTEMP(II))/(XTEMP(II)
  -XTEMP(IO))
  OXLAM(K)=XLAND(II)+(XLAND(II)-XLAND(IO))*(TEMP-XTEMP(II))/(XTEMP(II)
  -XTEMP(IO))
  OXMUL(K)=XMUL(II)+(XMUL(II)-XMUL(IO))*(TEMP-XTEMP(II))/(XTEMP(II)-
  XTEMP(IO))
  OXMUV(K)=XMUV(II)+(XMUV(II)-XMUV(IO))*(TEMP-XTEMP(II))/(XTEMP(II)-
  XTEMP(IO))
  IF (POINT.EQ.1) GO TO 61
  GO TO 57
68 CONTINUE
57 CONTINUE
61 CALL POUT2 (NK,OTEMP,OPRES,ORHOL,ORHOV,OSIGM,OXLAM,OXMUL,OXMUV,GAM
  MA,XMW,NBRIT,OTHCL,POINT,LSUPP)
  IF (POINT.EQ.1) GO TO 10
  IF (TEMP.LE.TMAX) GO TO 99
  IF (NBRIT.NE.0) GO TO 62
  NBRIT=1
  IF (UNITS.EQ.2) GO TO 12
  GO TO 62
34 A1=XTEMP(1)
  A2=XTEMP(MM)

```

```

IF (POINT.EQ.1) GO TO 55
TEMP=0.0
GO TO 66
55 TMIN=0.0
  TMAX=0.0
66 CALL POUT3 (A1,A2,NBRIT,UNITS,POINT,TEMP,TMIN,TMAX,LGUT)
63 IF (UNITS.NE.2) GO TO 62
  IF (NBRIT.NE.0) GO TO 62
  NBRIT=1
  IF (POINT.NE.1) GO TO 31
  GO TO 64
62 RETURN
  END

```

```

SUBROUTINE ACETO (LSUPP,LOUT,NBRIT,POINT,UNITS,ORHOL,ORHOV,OXLAM,OSIGM,OXMUL,OXMUV,TEMP,OPRES,XMW,GAMMA)
DIMENSION XMUL(30),XMUV(30),HD(2,2),XLAND(30),OXMUL(8),OXMUV(8)
DIMENSION XTEMP(30),PRESS(30),RHOV(30),RHOL(30),SIGMA(30)
DIMENSION OTHCL(8),OXLAM(8),OTEMP(8),OPRES(8),ORHOL(8),ORHOV(8)
DIMENSION OSIGM(8),THECL(30)
INTEGER POINT,UNITS
15 FORMAT (//' NOTE INPUT TEMPERATURE RANGE HAS BEEN ADJUSTED')
16 FORMAT ('I')
  MM=13
  IND=0
  NBRIT=0
  GAMMA=1.1
  XMW=58.0
  FCHEIT=509.5
  THECLT=178.5
  TBUIL=329.7
  PCRIFF=47.2*1.01325*10.0**5
  DATA (HD(1,1),I=1,2),HD(1,2)/7HACETONE,5HC3H6O/
  DATA (XTEMP(1),I=1,13)/325.0,335.0,345.0,355.0,365.0,375.0,385.0,
  1395.0,405.0,415.0,425.0,435.0,445.0/
  DATA (PRESS(1),I=1,13)/8.53E+4,1.20E+5,1.61E+5,2.16E+5,2.92E+5,3.7
  16E+5,4.84E+5,6.12E+5,7.46E+5,9.33E+5,1.13E+6,1.36E+6,1.65E+6/
  DATA (RHOL(1),I=1,13)/ 7.55E+2,7.41E+2,7.29E+2,7.17E+2,7.02E+2,6.9
  10E+2,6.75E+2,6.62E+2,6.48E+2,6.32E+2,6.18E+2,6.00E+2,5.82E+2/
  DATA (RHOV(1),I=1,13)/ 1.89E+0,2.56E+0,3.36E+0,4.37E+0,5.62E+0,7.0
  18E+0,8.97E+0,1.09E+1,1.35E+1,1.60E+1,1.92E+1,2.24E+1,2.60E+1/
  DATA (SIGMA(1),I=1,13)/1.89E-2,1.77E-2,1.64E-2,1.52E-2,1.40E-2,1.2
  18E-2,1.16E-2,1.03E-2,9.10E-3,7.80E-3,6.60E-3,5.40E-3,4.10E-3/
  DATA (XLAND(1),I=1,13)/5.11E+5,5.00E+5,4.86E+5,4.69E+5,4.60E+5,4.4
  16E+5,4.37E+5,4.23E+5,4.14E+5,3.95E+5,3.83E+5,3.72E+5,3.60E+5/
  DATA (XMUL(1),I=1,13)/ 2.50E-4,2.23E-4,2.09E-4,1.94E-4,1.80E-4,1.7
  10E-4,1.62E-4,1.52E-4,1.47E-4,1.40E-4,1.34E-4,1.29E-4,1.24E-4/
  DATA (XMUV(1),I=1,13)/ 8.20E-6,8.50E-6,8.70E-6,8.90E-6,9.10E-6,9.4
  10E-6,9.60E-6,9.70E-6,9.90E-6,1.00E-5,1.02E-5,1.04E-5,1.06E-5/
  DATA (THECL(1),I=1,13)/1.61E-1,1.57E-1,1.54E-1,1.49E-1,1.45E-1,1.4
  12E-1,1.37E-1,1.33E-1,1.30E-1,1.25E-1,1.21E-1,1.16E-1,1.12E-1/
  NIND=1
  IF (LSUPP.GT.1) GO TO 12
  READ (5,30) POINT,UNITS
30 FORMAT (I0I3)
12 IF (POINT-1) 31,32,31

```

C2-52

```

32 IF (NBRIT.EQ.1) GO TO 64
   IF (LSUPP.GT.1) GO TO 64
   READ (5,33) TEMP
33 FORMAT (BF10.4)
64 IF (TEMP.LT.XTEMP(1)) GO TO 34
   IF (TEMP.GT.XTEMP(MM)) GO TO 34
   GO TO 11
31 READ (5,33) TMIN,TMAX,DT
   IF (NBRIT.NE.1) GO TO 5
   TMIN=(TMIN+459.67)*5.0/9.0
   TMAX=(TMAX+459.67)*5.0/9.0
   DT=DT*5.0/9.0
   5 IF (TMIN.GT.XTEMP(MM)) GO TO 34
   IF (TMAX.LT.XTEMP(1)) GO TO 34
   IF (TMIN.GE.XTEMP(1)) GO TO 43
   IND=1
   TMIN=XTEMP(1)
43 IF (TMAX.LE.XTEMP(MM)) GO TO 44
   IND=1
   TMAX=XTEMP(MM)
44 TEMP=TMIN
11 CALL POUT1(HD,XMW,TMELT,TBDIL,TCRIT,PCRIT,NBRIT,GAMMA,LSUPP)
   IF (POINT.NE.1) GO TO 20
   IF (TEMP.LT.XTEMP(1)) GO TO 63
   IF (TEMP.GT.XTEMP(MM)) GO TO 63.
20 IF (POINT.EQ.1) GO TO 21
   IF (TMIN.GT.XTEMP(MM)) GO TO 10
   IF (TMAX.LT.XTEMP(1)) GO TO 10
21 IF (IND.EQ.0) GO TO 14
   WRITE (6,16)
   WRITE (6,15)
14 IF (POINT=1) 45,46,45
46 DT=0.0
   TMAX=TEMP
45 TEMP=TEMP-DT
99 DO 57 K=1,8
   TEMP=TEMP+DT
   IF (K.NE.1) GO TO 88
   IF (TEMP.GT.TMAX) GO TO 63
88 IF (TEMP.GT.TMAX) GO TO 61
   NK=K
   DO 68 I=NIND,MM
   IF (XTEMP(I)-TEMP) 68,59,60
59 II=1
   OTEMP(K)=TEMP
   OPRES(K)=PRESS(II)
   ORHOL(K)=RHOL(II)
   ORHOV(K)=RHOV(II)
   OSIGM(K)=SIGMA(II)
   OXLAM(K)=XLAMD(II)
   OXMUL(K)=XMUL(II)
   OXMUV(K)=XMUV(II)
   OTHCL(K)=THECL(II)
   IF (POINT.EQ.1) GO TO 61
   GO TO 57
60 IF (I.EQ.1) GO TO 59
   II=1
   IO=I-1

```

```

   OTEMP(K)=TEMP
   OPRES(K)=EXP((ALOG(PRESS(II))-ALOG(PRESS(IO)))*TEMP+(XTEMP(II)*AL
LOG(PRESS(IO))-XTEMP(IO)*ALOG(PRESS(II)))/(XTEMP(II)-XTEMP(IO)))
   ORHOL(K)=EXP((ALOG(RHOL(II))-ALOG(RHOL(IO)))*TEMP+(XTEMP(II)*AL
LOG(RHOL(IO))-XTEMP(IO)*ALOG(RHOL(II)))/(XTEMP(II)-XTEMP(IO)))
   ORHOV(K)=EXP((ALOG(RHOV(II))-ALOG(RHOV(IO)))*TEMP+(XTEMP(II)*AL
LOG(RHOV(IO))-XTEMP(IO)*ALOG(RHOV(II)))/(XTEMP(II)-XTEMP(IO)))
   OTHCL(K)=THECL(II)+(THECL(II)-THECL(IO))*(TEMP-XTEMP(II))/(XTEMP(
II)-XTEMP(IO))
   OSIGM(K)=SIGMA(II)+(SIGMA(II)-SIGMA(IO))*(TEMP-XTEMP(II))/(XTEMP(
II)-XTEMP(IO))
   OXLAM(K)=XLAMD(II)+(XLAMD(II)-XLAMD(IO))*(TEMP-XTEMP(II))/(XTEMP(
II)-XTEMP(IO))
   OXMUL(K)=XMUL(II)+(XMUL(II)-XMUL(IO))*(TEMP-XTEMP(II))/(XTEMP(II)-
XTEMP(IO))
   OXMUV(K)=XMUV(II)+(XMUV(II)-XMUV(IO))*(TEMP-XTEMP(II))/(XTEMP(II)-
XTEMP(IO))
   IF (POINT.EQ.1) GO TO 61
   GO TO 57
68 CONTINUE
57 CONTINUE
61 CALL POUT2 (NK,OTEMP,OPRES,ORHOL,ORHOV,OSIGM,OXLAM,OXMUL,OXMUV,GAM
MA,XMW,NBRIT,OTHCL,POINT,LSUPP)
   IF (POINT.EQ.1) GO TO 10
   IF (TEMP.LE.TMAX) GO TO 99
10 IF (NBRIT.NE.0) GO TO 62
   NBRIT=1
   IF (UNITS.EQ.2) GO TO 12
   GO TO 62
34 A1=XTEMP(1)
   A2=XTEMP(MM)
   IF (POINT.EQ.1) GO TO 55
   TEMP=0.0
   GO TO 66
55 TMIN=0.0
   TMAX=0.0
66 CALL POUT3 (A1,A2,NBRIT,UNITS,POINT,TEMP,TMIN,TMAX,LOUT)
63 IF (UNITS.NE.2) GO TO 62
   IF (NBRIT.NE.0) GO TO 62
   NBRIT=1
   IF (POINT.NE.1) GO TO 31
   GO TO 64
62 RETURN
   END

```

```

SUBROUTINE FREZ1 (LSUPP,LOUT,NBRIT,POINT,UNITS,ORHOL,ORHOV,OXLAM,O
SIGM,OXMUL,OXMUV,TEMP,OPRES,XMW,GAMMA)
DIMENSION XMUL(30),XMUV(30),HD(2,2),XLAMD(30),OXMUL(8),OXMUV(8)
DIMENSION XTEMP(30),PRESS(30),RHOV(30),RHOL(30),SIGMA(30)
DIMENSION OTHCL(8),OXLAM(8),OTEMP(8),OPRES(8),ORHOL(8),ORHOV(8)
DIMENSION OSIGM(8),THECL(30)
INTEGER POINT,UNITS
16 FORMAT ('*')
15 FORMAT (/'*') NOTE INPUT TEMPERATURE RANGE HAS BEEN ADJUSTED*
MM=14

```

```

IND=0
NRKIT=0
GAMMA=1.175
XNW=102.93
TCRIT=451.7
TMELT=138.2
TBOIL=282.12
PCRIT=750.*6.895*10.**3
DATA (MDI(1,1),1=1,2),MD(1,2)/MHF-ACN-21,6MCHCL2F/
DATA (XTEMP(1),1=1,14)/235.0,240.0,245.0,250.0,255.0,260.0,265.0,2
170.0,275.0,280.0,290.0,300.0,310.0,320.0/
DATA (PRESS(1),1=1,14)/1.11E+4,1.45E+4,1.93E+4,2.45E+4,3.16E+4,4.0
13E+4,5.12E+4,6.28E+4,7.80E+4,9.62E+4,1.40E+5,1.76E+5,2.68E+5,3.65E
2+5/
DATA (RHOL(1),1=1,14)/1.50E+3,1.49E+3,1.48E+3,1.47E+3,1.46E+3,1.45
1E+3,1.44E+3,1.43E+3,1.42E+3,1.41E+3,1.39E+3,1.36E+3,1.33E+3,1.31E+
23/
DATA (RHOV(1),1=1,14)/5.70E-1,7.50E-1,9.40E-1,1.21E+0,1.55E+0,1.93
1E+0,2.42E+0,2.90E+0,3.60E+0,4.22E+0,5.88E+0,8.10E+0,1.14E+1,1.50E+
21/
DATA (SIGMA(1),1=1,14)/2.75E-2,2.67E-2,2.58E-2,2.51E-2,2.42E-2,2.3
15E-2,2.28E-2,2.20E-2,2.14E-2,2.07E-2,1.92E-2,1.78E-2,1.64E-2,1.48E
12/
DATA (XLAMD(1),1=1,14)/2.65E+5,2.63E+5,2.61E+5,2.58E+5,2.56E+5,2.5
14E+5,2.51E+5,2.49E+5,2.46E+5,2.44E+5,2.38E+5,2.33E+5,2.27E+5,2.20E
2+5/
DATA (XNUL(1),1=1,14)/6.00E-4,5.65E-4,5.34E-4,5.06E-4,4.80E-4,4.56
1E-4,4.33E-4,4.15E-4,3.96E-4,3.80E-4,3.52E-4,3.26E-4,3.05E-4,2.85E-
24/
DATA (XMUV(1),1=1,14)/8.40E-6,8.65E-6,8.95E-6,9.20E-6,9.50E-6,9.73
1E-6,1.00E-5,1.02E-5,1.05E-5,1.07E-5,1.11E-5,1.15E-5,1.19E-5,1.23E-
25/
DATA (THECL(1),1=1,14)/1.40E-1,1.38E-1,1.35E-1,1.33E-1,1.30E-1,1.2
18E-1,1.25E-1,1.23E-1,1.20E-1,1.18E-1,1.13E-1,1.10E-1,1.03E-1,9.80E
2-2/
NIND=1
IF (LSUPP.GT.1) GO TO 12
READ (5,30) POINT,UNITS
30 FORMAT (10I3)
12 IF (POINT-1) 31,32,31
32 IF (NRKIT.EQ.1) GO TO 64
IF (LSUPP.GT.1) GO TO 64
READ (5,33) TEMP
33 FORMAT (8F10.4)
64 IF (TEMP.LT.XTEMP(1)) GO TO 34
IF (TEMP.GT.XTEMP(MM)) GO TO 34
GO TO 11
31 READ (5,33) TMIN,TMAX,DT
IF (NRKIT.NE.1) GO TO 5
TMIN=(TMIN+459.67)*5.0/9.0
TMAX=(TMAX+459.67)*5.0/9.0
DT=DT*5.0/9.0
5 IF (TMIN.GT.XTEMP(MM)) GO TO 34
IF (TMAX.LT.XTEMP(1)) GO TO 34
IF (TMIN.GE.XTEMP(1)) GO TO 43
IND=1
TMIN=XTEMP(1)
43 IF (TMAX.LE.XTEMP(MM)) GO TO 44

```

```

IND=1
TMAX=XTEMP(MM)
44 TEMP=TMIN
11 CALL POUT(IND,XNW,TMELT,TBOIL,TCRIT,PCRIT,NRKIT,GAMMA,LSUPP)
IF (POINT.NE.1) GO TO 20
IF (TEMP.LT.XTEMP(1)) GO TO 63
IF (TEMP.GT.XTEMP(MM)) GO TO 63
20 IF (POINT.EQ.1) GO TO 21
IF (TMIN.LT.XTEMP(MM)) GO TO 10
IF (TMAX.LT.XTEMP(1)) GO TO 10
21 IF (IND.EQ.0) GO TO 14
WRITE (6,15)
WRITE (6,15)
14 IF (POINT-1) 45,46,45
46 DT=0.0
TMAX=TEMP
45 TEMP=TEMP-DT
99 DO 57 K=1,8
TEMP=TEMP+DT
IF (K.NE.1) GO TO 88
IF (TEMP.GT.TMAX) GO TO 63
88 IF (TEMP.GT.TMAX) GO TO 61
NRK=K
DO 68 I=NIND,MM
IF (XTEMP(I)-TEMP) 68,59,60
59 I=I
OTEMP(K)=TEMP
UPRES(K)=PRESS(I)
URHOL(K)=RHOL(I)
ORHOV(K)=RHOV(I)
OSIGM(K)=SIGMA(I)
OXLAM(K)=XLAMD(I)
OXMUL(K)=XMUL(I)
OXMUV(K)=XMUV(I)
OTHCL(K)=THECL(I)
IF (POINT.EQ.1) GO TO 61
GO TO 57
60 IF (I.EQ.1) GO TO 59
I=I-1
OTEMP(K)=TEMP
UPRES(K)=EXP((ALOG(PRESS(I))-ALOG(PRESS(I0))*TEMP+(XTEMP(I)-OAL
LOG(PRESS(I0))-XTEMP(I0)*ALOG(PRESS(I)))/(XTEMP(I)-XTEMP(I0)))
URHOL(K)=RHOL(I)+(RHOL(I)-RHOL(I0))*(TEMP-XTEMP(I))/(XTEMP(I)-
XTEMP(I0))
ORHOV(K)=EXP((ALOG(RHOV(I))-ALOG(RHOV(I0))*TEMP+(XTEMP(I)-OAL
LOG(RHOV(I0))-XTEMP(I0)*ALOG(RHOV(I)))/(XTEMP(I)-XTEMP(I0)))
OTHCL(K)=THECL(I)+(THECL(I)-THECL(I0))*(TEMP-XTEMP(I))/(XTEMP(I
I)-XTEMP(I0))
OSIGM(K)=SIGMA(I)+(SIGMA(I)-SIGMA(I0))*(TEMP-XTEMP(I))/(XTEMP(I
I)-XTEMP(I0))
OXLAM(K)=XLAMD(I)+(XLAMD(I)-XLAMD(I0))*(TEMP-XTEMP(I))/(XTEMP(I
I)-XTEMP(I0))
OXMUL(K)=XMUL(I)+(XMUL(I)-XMUL(I0))*(TEMP-XTEMP(I))/(XTEMP(I)-
XTEMP(I0))
OXMUV(K)=XMUV(I)+(XMUV(I)-XMUV(I0))*(TEMP-XTEMP(I))/(XTEMP(I)-
XTEMP(I0))
IF (POINT.EQ.1) GO TO 61

```

GO TO 57
 60 CONTINUE
 57 CONTINUE
 61 CALL POUT2 (NK,OTEMP,OPRES,ORHOL,ORHOV,OSIGM,OXLAM,OXMUL,OXMUV,GAM
 MA,XMM,NBRIT,OTHCL,POINT,LSUPP)
 IF (POINT.EQ.1) GO TO 10
 IF (TEMP.LE.TMAX) GO TO 99
 10 IF (NBRIT.NE.0) GO TO 62
 NBRIT=1
 IF (UNITS.EQ.2) GO TO 12
 GO TO 62
 34 A1=XTEMP(1)
 A2=XTEMP(MM)
 IF (POINT.EQ.1) GO TO 55
 TEMP=0.0
 GO TO 66
 55 TMIN=0.0
 TMAX=0.0
 66 CALL POUT3 (A1,A2,NBRIT,UNITS,POINT,TEMP,TMIN,TMAX,LOUT)
 63 IF (UNITS.NE.2) GO TO 62
 IF (NBRIT.NE.0) GO TO 62
 NBRIT=1
 IF (POINT.NE.1) GO TO 31
 GO TO 64
 62 RETURN
 END

SUBROUTINE SODIU (LSUPP,LOUT,NBRIT,POINT,UNITS,ORHOL,ORHOV,OXLAM,OS
 ISIGM,OXMUL,OXMUV,TEMP,OPRES,XMM,GAMMA)
 DIMENSION HD(2,2),XTEMP(2),OTHCL(8),OXLAM(8),OTEMP(8),OPRES(8)
 DIMENSION ORHOL(8),ORHOV(8),OSIGM(8),OXMUL(8),OXMUV(8)
 INTEGER POINT,UNITS
 16 FORMAT (*1*)
 15 FORMAT (///* NOTE INPUT TEMPERATURE RANGE HAS BEEN ADJUSTED*)
 MM=2
 IND=0
 NBRIT=0
 GAMMA=5.0/3.0
 XMM=22.991
 TCRIT=2600.0
 TMELT=371.0
 TBUIL=1156.2
 PCRIT=187.2*1.01325*10**5
 DATA (HD(1,1),I=1,2),HD(1,2)/8MSODIUM ,2HNA/
 DATA (XTEMP(1),I=1,2)/371.0,2200.0/
 NIND=1
 IF (LSUPP.GT.1) GO TO 12
 READ (5,30) POINT,UNITS
 30 FORMAT (LO13)
 12 IF (POINT=1) 31,32,31
 32 IF (NBRIT.EQ.1) GO TO 64
 IF (LSUPP.GT.1) GO TO 64
 READ (5,33) TEMP
 33 FORMAT (8F10.4)
 64 IF (TEMP.LT.XTEMP(1)) GO TO 34

IF (TEMP.GT.XTEMP(MM)) GO TO 34
 GO TO 11
 11 READ (5,33) TMIN,TMAX,OT
 IF (NBRIT.NE.1) GO TO 5
 TMIN=(TMIN+459.67)*5.0/9.0
 TMAX=(TMAX+459.67)*5.0/9.0
 OT=OT*5.0/9.0
 5 IF (TMIN.GT.XTEMP(MM)) GO TO 34
 IF (TMAX.LT.XTEMP(1)) GO TO 34
 IF (TMIN.GE.XTEMP(1)) GO TO 43
 IND=1
 TMIN=XTEMP(1)
 43 IF (TMAX.LE.XTEMP(MM)) GO TO 44
 IND=1
 TMAX=XTEMP(MM)
 44 TEMP=TMIN
 11 CALL POUT1 (HD,XMM,TMELT,TBUIL,TCRIT,PCRIT,NBRIT,GAMMA,LSUPP)
 IF (POINT.NE.1) GO TO 20
 IF (TEMP.LT.XTEMP(1)) GO TO 63
 IF (TEMP.GT.XTEMP(MM)) GO TO 63
 20 IF (POINT.EQ.1) GO TO 21
 IF (TMIN.GT.XTEMP(MM)) GO TO 10
 IF (TMAX.LT.XTEMP(1)) GO TO 10
 21 IF (IND.EQ.0) GO TO 14
 WRITE (6,16)
 WRITE (6,15)
 14 IF (POINT=1) 45,46,45
 46 OT=0.0
 TMAX=TEMP
 45 TEMP=TEMP-OT
 99 GO 57 K=1,8
 TEMP=TEMP+OT
 IF (K.NE.1) GO TO 88
 IF (TEMP.GT.TMAX) GO TO 63
 88 IF (TEMP.GT.TMAX) GO TO 61
 NK=K
 OTEMP(K)=TEMP
 UPRES(K)=(EXP(19.983175-10918.06/TEMP-686231.9/TEMP**2))*10.0**5
 ORHOL(K)=(1.013638-0.0002350445*TEMP-0.000000009861048*TEMP**2)*1
 10.0**3
 ORHOV(K)=(EXP(1.000785-10129.16/TEMP-575469.0/TEMP**2))*1000.
 TF=1.8*TEMP-459.67
 OTHCL(K)=(1.4298-0.00061292*TF+0.00000017127*TF**2-0.0000000000306
 133*TF**3)*70.87
 OSIGM(K)=(220.0-0.091*TEMP)*0.001
 OXLAM(K)=(4178.649+0.2829841*TEMP-0.0004765964*TEMP**2)*1000.0
 OXMUL(K)=0.893*EXP(1517.0/(TEMP*1.9859))/10.0**4
 OXMUV(K)=(0.0000705571+0.0000001581986*TEMP-0.0000000001938133*TE
 MP**2)*0.1
 IF (POINT.EQ.1) GO TO 61
 57 CONTINUE
 61 CALL POUT2 (NK,OTEMP,OPRES,ORHOL,ORHOV,OSIGM,OXLAM,OXMUL,OXMUV,GAM
 MA,XMM,NBRIT,OTHCL,POINT,LSUPP)
 IF (POINT.EQ.1) GO TO 10
 IF (TEMP.LE.TMAX) GO TO 99
 10 IF (NBRIT.NE.0) GO TO 62
 NBRIT=1
 NIND=1

```

IF (UNITS.EQ.2) GO TO 12
GO TO 62
34 A1=XTEMP(1)
A2=XTEMP(MM)
IF (POINT.EQ.1) GO TO 55
TEMP=0.0
GO TO 66
55 TMIN=0.0
TMAX=0.0
66 CALL POUT3 (A1,A2,NBRIT,UNITS,POINT,TEMP,TMIN,TMAX,LOUT)
63 IF (UNITS.NE.2) GO TO 62
63 IF (NBRIT.NE.0) GO TO 62
NBRIT=1
IF (POINT.NE.1) GO TO 31
GO TO 64
62 RETURN
END

```

```

SUBROUTINE POTAS (LSUPP,LOUT,NBRIT,POINT,UNITS,ORHOL,ORHOV,OXLAM,0
OSIGN,DXMUL,OXMUV,TEMP,OPRES,XMW,GAMMA)
DIMENSION MD(2,2),XTEMP(2),DTHCL(8),OXLAM(8),OTEMP(8),OPRES(8)
DIMENSION ORHOL(8),ORHOV(8),OSIGN(8),DXMUL(8),OXMUV(8)
INTEGER POINT,UNITS
15 FORMAT (//) NOTE INPUT TEMPERATURE RANGE HAS BEEN ADJUSTED*
16 FORMAT ('*')
MM=2
IND=0
NBRIT=0
GAMMA=5.0/3.0
XMW=39.1
TCRIT=2300.0
TMELT=336.9
TBQIL=1033.2
PCRIT=0.0
DATA (MD(1,1),I=1,2),MD(1,2)/9HPDASSIUM,1MK/
DATA (XTEMP(I),I=1,2)/336.9,1900.0/
NIND=1
IF (LSUPP.GT.1) GO TO 12
READ (5,30) POINT,UNITS
30 FORMAT (10I3)
12 IF (POINT=1) 31,32,31
32 IF (NBRIT.EQ.1) GO TO 64
IF (LSUPP.GT.1) GO TO 64
READ (5,33) TEMP
33 FORMAT (8F10.4)
64 IF (TEMP.LT.XTEMP(1)) GO TO 34
IF (TEMP.GT.XTEMP(MM)) GO TO 34
GO TO 11
31 READ (5,33) TMIN,TMAX,DT
IF (NBRIT.NE.1) GO TO 5
TMIN=(TMIN+459.67)*5.0/9.0
TMAX=(TMAX+459.67)*5.0/9.0
DT=DT*5.0/9.0
IF (TMIN.GT.XTEMP(MM)) GO TO 34
IF (TMAX.LT.XTEMP(1)) GO TO 34
IF (TMIN.GE.XTEMP(1)) GO TO 43

```

```

IND=1
TMIN=XTEMP(1)
43 IF (TMAX.LE.XTEMP(MM)) GO TO 44
IND=1
TMAX=XTEMP(MM)
44 TEMP=TMIN
11 CALL POUT1(HO,XMW,TMELT,THOIL,TCRIT,PCRIT,NBRIT,GAMMA,LSUPP)
IF (POINT.NE.1) GO TO 20
IF (TEMP.LT.XTEMP(1)) GO TO 63
IF (TEMP.GT.XTEMP(MM)) GO TO 63
20 IF (POINT.EQ.1) GO TO 21
IF (TMIN.GT.XTEMP(MM)) GO TO 10
IF (TMAX.LT.XTEMP(1)) GO TO 10
21 IF (IND.EQ.0) GO TO 14
WRITE (6,16)
WRITE (6,15)
14 IF (POINT=1) 45,46,45
46 DT=0.0
TMAX=TEMP
45 TEMP=TEMP-DT
99 DO 57 K=1,8
TEMP=TEMP+DT
IF (K.NE.1) GO TO 88
IF (TEMP.GT.TMAX) GO TO 63
88 IF (TEMP.GT.TMAX) GO TO 61
NK=K
OTEMP(K)=TEMP
OPRES(K)=(EXP(19.191863-9030.992/TEMP-433038.0/TEMP**2))*10.0**5
ORHOL(K)=(0.9083578-0.0002244534*TEMP-0.00000001274617*TEMP**2)*10
100.0
ORHOV(K)=(EXP(10.8135742-8241.15/TEMP-426986.1/TEMP**2))*1000.0
IF=1.8*TEMP-459.67
DTHCL(K)=(0.96689-0.00047904*TF+0.00000013778*TF**2-0.000000000024
1884*TF**3)*70.87
OSIGN(K)=(14590.0*(0.0084029-0.000028149*TF)**0.001
OXLAM(K)=(2269.079-0.1318445*TEMP-0.0002003039*TEMP**2)*1000.0
DXMUL(K)=(-0.0004390586+2.028652/TEMP-541.0948/TEMP**2+164680.4/TE
MP**3)*0.1
OXMUV(K)=(0.00003670094+0.0000001982508*TEMP-0.0000000000452833*TE
MP**2)*0.1
IF (POINT.EQ.1) GO TO 61
57 CONTINUE
61 CALL POUT2 (NK,OTEMP,OPRES,ORHOL,ORHOV,OSIGN,OXLAM,DXMUL,OXMUV,GAM
MA,XMW,NBRIT,DTHCL,POINT,LSUPP)
IF (POINT.EQ.1) GO TO 10
IF (TEMP.LE.TMAX) GO TO 99
13 IF (NBRIT.NE.0) GO TO 62
NBRIT=1
NIND=1
IF (UNITS.EQ.2) GO TO 12
GO TO 62
34 A1=XTEMP(1)
A2=XTEMP(MM)
IF (POINT.EQ.1) GO TO 55
TEMP=0.0
GO TO 66
55 TMIN=0.0
TMAX=0.0

```



```

66 CALL POUT3 (A1,A2,NBRIT,UNITS,POINT,TEMP,TMIN,TMAX,LOUT)
63 IF (UNITS.NE.2) GO TO 62
  IF (NBRIT.NE.0) GO TO 62
  NHRIT=1
  IF (POINT.NE.1) GO TO 31
  GO TO 64
62 RETURN
  END

```

```

SUBROUTINE LITHI (LSUPP,LOUT,NBRIT,POINT,UNITS,ORHOL,ORHOV,OXLAM,O
  ISIGN,OXMUL,OXMUV,TEMP,OPRES,XMW,GAMMA)
  DIMENSION HD(2,2),XTEMP(2),OTHCL(8),OXLAM(8),OTEMP(8),OPRES(8)
  DIMENSION ORHOL(8),ORHOV(8),OSIGN(8),OXMUL(8),OXMUV(8)
  INTEGER POINT,UNITS
16 FORMAT ('*')
15 FORMAT (//) NOTE INPUT TEMPERATURE RANGE HAS BEEN ADJUSTED*)
  MM=2
  IND=0
  NBRIT=0
  GAMMA=5.0/3.0
  XMW=6.939
  TCRIT=3500.0
  TMELT=453.0
  TBOIL=1413.0
  PCRIT=0.0
  DATA (HD(1,1),1=1,2),HD(1,2)/7HLITHIUM,2HLI/
  DATA (XTEMP(1),1=1,2)/453.0,2100.0/
  NIND=1
  IF (LSUPP.GT.1) GO TO 12
  READ (5,30) POINT,UNITS
30 FORMAT (10I3)
12 IF (POINT-1) 21,32,31
32 IF (NBRIT.EQ.1) GO TO 64
  IF (LSUPP.GT.1) GO TO 64
  READ (5,33) TEMP
33 FORMAT (BF10.4)
64 IF (TEMP.LT.XTEMP(1)) GO TO 34
  IF (TEMP.GT.XTEMP(MM)) GO TO 34
  GO TO 11
31 READ (5,33) TMIN,TMAX,DT
  IF (NBRIT.NE.1) GO TO 5
  TMIN=(TMIN+459.67)*5.0/9.0
  TMAX=(TMAX+459.67)*5.0/9.0
  DT=DT*5.0/9.0
  5 IF (TMIN.GT.XTEMP(MM)) GO TO 34
  IF (TMAX.LT.XTEMP(1)) GO TO 34
  IF (TMIN.GE.XTEMP(1)) GO TO 43
  IND=1
  TMIN=XTEMP(1)
43 IF (TMAX.LE.XTEMP(MM)) GO TO 44
  IND=1
  TMAX=XTEMP(MM)
44 TEMP=TMIN
11 CALL POUT1(HD,XMW,TMELT,TBOIL,TCRIT,PCRIT,NBRIT,GAMMA,LSUPP)
  IF (POINT.NE.1) GO TO 20

```

```

  IF (TEMP.LT.XTEMP(1)) GO TO 63
  IF (TEMP.GT.XTEMP(MM)) GO TO 63
20 IF (POINT.EQ.1) GO TO 21
  IF (TMIN.GT.XTEMP(MM)) GO TO 10
  IF (TMAX.LT.XTEMP(1)) GO TO 10
21 IF (IND.EQ.0) GO TO 14
  WRITE (6,15)
  WRITE (6,15)
14 IF (POINT-1) 45,46,45
46 DT=0.0
  TMAX=TEMP
45 TEMP=TEMP-DT
99 DO 57 K=1,8
  TEMP=TEMP+DT
  IF (K.NE.1) GO TO 85
  IF (TEMP.GT.TMAX) GO TO 63
88 IF (TEMP.GT.TMAX) GO TO 61
  NK=K
  OTEMP(K)=TEMP
  OPRES(K)=1.01356*10.0**((4.8831-7877.9/TEMP)*10.0**5
  URHOL(K)=(0.546398-0.00009381799*TEMP+0.00000009318741*TEMP**2)*1
  10**3
  URHOV(K)=(EXP(0.4324234-15605.72/TEMP-1124864.0/TEMP**2))*10.0**3
  IF=TEMP*9.0/5.0-459.67
  OTHCL(K)=(0.49998*0.00027992*TF+0.000000022565*TF**2-0.00000000002
  14606*TF**3)*70.87
  USIGN(K)=(1454.4948-0.1356226*TEMP+0.000001615487*TEMP**2)*0.001
  OXLAM(K)=(26390.0-5.325*TEMP+0.000625*TEMP**2)*1000.0
  OXMUL(K)=(0.002924347-2.648556/TEMP+2995.261/TEMP**2-530257.4/TEMP
  1**3)*0.1
  OXMUV(K)=(0.00003673815+0.0000001167182*TEMP-0.0000000001135025*
  TEMP**2)*0.1
  IF (POINT.EQ.1) GO TO 61
57 CONTINUE
61 CALL POUT2 (NK,OTEMP,OPRES,ORHOL,ORHOV,OSIGN,OXLAM,OXMUL,OXMUV,GAM
  MA,XMW,NBRIT,OTHCL,POINT,LSUPP)
  IF (POINT.EQ.1) GO TO 10
  IF (TEMP.LE.TMAX) GO TO 69
20 IF (NBRIT.NE.0) GO TO 62
  NBRIT=1
  NIND=1
  IF (UNITS.EQ.2) GO TO 12
  GO TO 62
34 A1=XTEMP(1)
  A2=XTEMP(MM)
  IF (POINT.EQ.1) GO TO 55
  TAMP=0.0
  GO TO 66
55 TMIN=0.0
  TMAX=0.0
66 CALL POUT3 (A1,A2,NBRIT,UNITS,POINT,TEMP,TMIN,TMAX,LOUT)
63 IF (UNITS.NE.2) GO TO 62
  IF (NBRIT.NE.0) GO TO 62
  NHRIT=1
  IF (POINT.NE.1) GO TO 31
  GO TO 64
62 RETURN
  END

```

```

SUBROUTINE MERCU (LSUPP,LOUT,NBRIT,POINT,UNITS,ORHOL,ORHOV,OXLAP,0
ISIGN,OXMUL,OXMOV,TEMP,OPRES,XMW,GAMMA)
DIMENSION HD(2,2),XTEMP(2),OTHCL(8),OXLAM(8),OTEMP(8),OPRES(8)
DIMENSION ORHUL(8),ORHOV(8),OSIGN(8),OXMUL(8),OXMOV(8)
INTEGER POINT,UNITS
16 FORMAT ('1')
19 FORMAT (//) NOTE INPUT TEMPERATURE RANGE HAS BEEN ADJUST(D)
MM=2
IND=0
NBRIT=0
GAMMA=5.0/3.0
XMW=200.61
TCRIT=1735.0
TMELT=234.33
TBOIL=630.2
PCRIT=1.05*10.0**8
DATA (HD(I,1),I=1,2),HD(1,2)/7HMERCURY,2MHG/
DATA (XTEMP(I),I=1,2)/234.33,900.0/
NIND=1
IF (LSUPP.GT.1) GO TO 12
READ (5,30) POINT,UNITS
30 FORMAT (10I3)
12 IF (POINT-1) 31,32,31
32 IF (NBRIT.EQ.1) GO TO 64
IF (LSUPP.GT.1) GO TO 64
READ (5,33) TEMP
33 FORMAT (8F10.4)
64 IF (TEMP.LT.XTEMP(1)) GO TO 34
IF (TEMP.GT.XTEMP(MM)) GO TO 34
GO TO 11
31 READ (5,3) TMIN,TMAX,DT
IF (NBRIT.NE.1) GO TO 5
TMIN=(TMIN+59.67)*5.0/9.0
TMAX=(TMAX+59.67)*5.0/9.0
DT=DT*5.0/9.0
5 IF (TMIN.GT.XTEMP(MM)) GO TO 34
IF (TMAX.LT.XTEMP(1)) GO TO 34
IF (TMIN.GE.XTEMP(1)) GO TO 43
IND=1
TMIN=XTEMP(1)
43 IF (TMAX.LE.XTEMP(MM)) GO TO 44
IND=1
TMAX=XTEMP(MM)
44 TEKP=TMIN
11 CALL POUT1(HD,XMW,TMELT,TBOIL,TCRIT,PCRIT,NBRIT,GAMMA,LSUPP)
IF (POINT.NE.1) GO TO 20
IF (TEMP.LT.XTEMP(1)) GO TO 63
IF (TEMP.GT.XTEMP(MM)) GO TO 63
20 IF (POINT.EQ.1) GO TO 21
IF (TMIN.GT.XTEMP(MM)) GO TO 10
IF (TMAX.LT.XTEMP(1)) GO TO 10
21 IF (IND.EQ.0) GO TO 14
WRITE (6,16)
WRITE (6,15)

```

```

14 IF (POINT-1) 45,46,45
46 DT=0.0
TMAX=TEMP
45 TEMP=TEMP-DT
99 DU 57 K=1,8
TEMP=TEMP+DT
IF (K.NE.1) GO TO 88
IF (TEMP.GT.TMAX) GO TO 63
88 IF (TEMP.GT.TMAX) GO TO 61
KK=K
OTEMP(K)=TEMP
UPRES(K)=(10.0**((10.3735-3308.0/TEMP-0.8*ALOG10(TEMP)))**133.3
C LIQUID-METALS HANDBOOK (ATOMIC ENERGY COMMISSION)
ORHOL(K)=(14.38176-0.002861766*TEMP+C.0000003763475*TEMP**2)*1000.
ORHOV(K)=(EXP(3.243496-4559.02/TEMP-607443.0/TEMP**2))*1000.
OTHCL(X)=(0.14648003+50.0368/TEMP-82000.5/TEMP**2+32629500.0/TEMP**
1*3-4436610000.0/TEMP**4)*100.0
OSIGN(K)=(487.6255+0.0013279*TEMP-0.0002458797*TEMP**2)*0.001
OXLAM(K)=(-0.024*TEMP+83.1568)*4184.0
OXMUL(K)=(0.008036587-3.198839/TEMP+2971.399/TEMP**2-354408.7/TEMP
1**3)*0.1
OXMOV(K)=(0.00007143205+0.000000630029*TEMP+0.0000000003373475*TEM
1P**2)*0.1
IF (POINT.EQ.1) GO TO 61
57 CONTINUE
61 CALL POUT2 (NK,OTEMP,OPRES,ORHOL,ORHOV,OSIGN,OXLAM,OXMUL,OXMOV,GAM
1MA,XMW,NBRIT,OTHCL,POINT,LSUPP)
IF (POINT.EQ.1) GO TO 10
IF (TEMP.LE.TMAX) GO TO 62
10 IF (NBRIT.NE.0) GO TO 62
NBRIT=1
NIND=1
IF (UNITS.EQ.2) GO TO 12
GO TO 62
34 A1=XTEMP(1)
A2=XTEMP(MM)
IF (POINT.EQ.1) GO TO 55
TEMP=0.0
GO TO 66
55 TMIN=0.0
TMAX=0.0
66 CALL POUT3 (A1,A2,NBRIT,UNITS,POINT,TEMP,TMIN,TMAX,LOUT)
63 IF (UNITS.NE.2) GO TO 62
IF (NBRIT.NE.0) GO TO 62
NBRIT=1
IF (POINT.NE.1) GO TO 31
GO TO 64
62 RETURN
END

```

REPRODUCIBILITY OF THIS
ORIGINAL

C.3 VARIABLE CONDUCTANCE HEAT PIPE ANALYSIS CODE USER'S MANUAL

C.3.1 Introduction

This section describes the utilization of a digital computer code for Variable Conductance Heat Pipe Analysis (VCHPA). This computer program considers the steady-state performance of cold-wicked reservoir gas-controlled heat pipes. The reservoir and inactive condenser section are assumed to be in thermal equilibrium with the sink temperature. Flat-front analysis is used with conduction and diffusion effects being assumed negligible. This code consists of the following analyses:

- Design Analysis
- Performance Analysis

In the Design Analysis, storage volume and gas charge requirements are calculated parametrically as a function of sink temperature range and allowable vapor temperature range (control sensitivity). The Performance Analysis presents a parametric study of performance for a system within the range of specified maximum conditions. The analysis and formulation of the equations used in the program are presented in Section C.3.2. A general description of the program is presented in Section C.3.3 along with a description of the program's input and output. Nomenclature is listed at the end of this section.

The flow diagrams, program listing, and sample problems are presented in the Appendices. A listing of FORTRAN names with engineering quantities is also included as an Appendix.

C.3.2 Analysis

Figure C.3.1 shows a schematic of a cold-wicked gas-controlled heat pipe and its assumed temperature distribution. A steady-state analysis has been performed to determine storage volume requirements and performance within the design range. The following assumptions were made in performing the analysis:

- Flat front analysis is applicable; i. e., thermal conduction and mass diffusion effects are negligible.

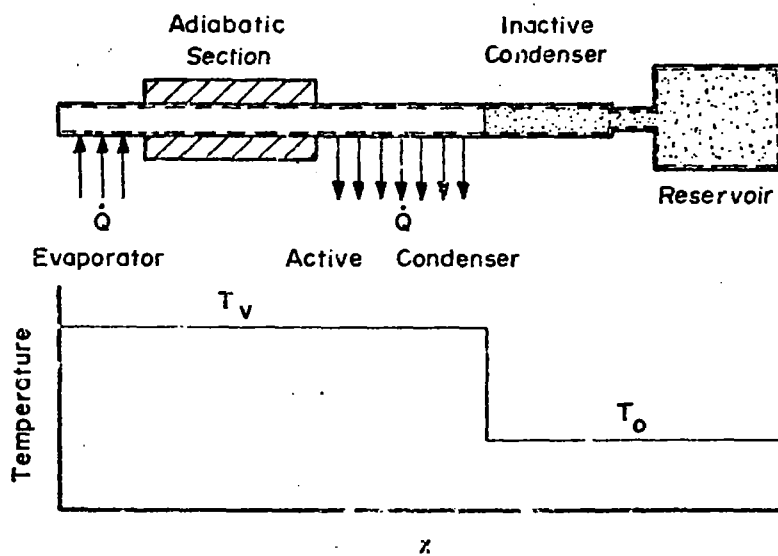

Figure C.3-1. Schematic of a Cold Wicked Gas-Controlled Heat Pipe and Its Assumed Temperature Distribution

- The entire condenser length is active at the maximum condition.
- The entire condenser is blocked at the minimum condition.
- The inactive part of the condenser and the reservoir are at the sink temperature T_o .
- The noncondensable gas obeys the Ideal Gas Equation of State.

Using these assumptions, the following equations apply:

- Conservation of Mass

$$m_g = m_{g,r} + m_{g,c} \quad \text{C. 3-1}$$

- Law of Additive Partial Pressures (applicable to inactive part of the condenser and also the storage volume)

$$\left. \begin{aligned} p_v &= p_{v,o} + p_{z,o} && \text{(Inactive Condenser)} \\ p_v &= p_{v,r} + p_{g,r} && \text{(Reservoir)} \end{aligned} \right\} \quad \text{C. 3-2}$$

- Ideal Gas Equation of State

$$(pV)_g = (mRT)_g \quad \text{C. 3-3}$$

The above equations yield the following relationship:

$$m_g = \left(\frac{p_v - p_{v,o}}{R_g T_o} \right) (V_r + V'_{v,c}) \quad \text{C. 3-4}$$

where $V'_{v,c}$ is the volume of the vapor space in the inactive condenser at the minimum condition. Thus at the maximum condition:

$$m_g = \left(\frac{p_v - p_{v,r}}{R_g T_r} \right)_{\max} V_r \quad \text{C. 3-5}$$

At the minimum condition:

$$m_g = \left(\frac{p_v - p_{v,o}}{R_g T_o} \right)_{\min} V'_{v,c} + \left(\frac{p_v - p_{v,r}}{R_g T_r} \right)_{\min} V_r \quad \text{C. 3-6}$$

The ratio of reservoir volume to condenser void (inactive volume of condenser) is obtained by equating Equation C. 3-5 and C. 3-6:

$$\frac{V_r}{V'_{v,c}} = \frac{1}{\left[\left(\frac{p_{v,\max} - p_{v,o,\max}}{p_{v,\min} - p_{v,o,\min}} \right) \left(\frac{T_{o,\min}}{T_{o,\max}} \right) - 1 \right]} \quad \text{C. 3-7}$$

The ratio of the mass of the noncondensing gas to the condenser volume is obtained from Equation C. 3-6:

$$\frac{m_g}{V'_{v,c}} = \frac{1}{R_g} \left(1 + \frac{V_r}{V'_{v,c}} \right) \frac{p_{v,\min} - p_{v,o,\min}}{T_{o,\min}} \quad \text{C. 3-8}$$

The heat transfer from the condenser to the sink can be defined as:

$$\dot{Q} = G_c (T_v - T_o) \quad \text{C. 3-9}$$

The maximum required conductance of the condenser is therefore:

$$G_{c,\max} = \frac{\dot{Q}_{\max}}{(T_{v,\max} - T_{o,\max})} \quad \text{C. 3-10}$$

Combining Equations C. 3-9 and C. 3-10, the heat transfer at any vapor and sink temperatures within the control range is:

$$\dot{Q} = G_{c,\max} \eta (T_v - T_o) \quad \text{C. 3-11}$$

where η is given by:

$$\eta = \frac{G_c}{G_{c,\max}} = 1 + \frac{V_r}{V'_{v,c}} - \frac{R_g m_g T_o}{V'_{v,c} (p_v - p_{v,o})} \quad \text{C. 3-12}$$

The Design Analysis consists of solving Equations C. 3-7 and C. 3-8 for the storage volume and gas charge requirements as a function of the sink temperature range and control sensitivity ΔT_v . The calculations are performed for a specified nominal operating temperature $\Delta T_{v,n}$ and minimum sink condition $T_{o,min}$ with maximum sink temperature as a parameter. For a given ΔT_v the maximum and minimum vapor temperatures are:

$$T_{v,max} = T_{v,n} + \frac{\Delta T_v}{2} \quad \text{C. 3-13}$$

$$T_{v,min} = T_{v,n} - \frac{\Delta T_v}{2} \quad \text{C. 3-14}$$

The control range is decreased in accordance with a specified ΔT_v increment until the storage requirement exceeds a specified maximum or becomes negative implying that a cold-wicked reservoir cannot provide the desired control. The analysis is repeated for successively increasing sink temperature ranges until the maximum specified range is reached.

In the Performance Analysis, the heat transport is calculated as a function of vapor and sink temperature. Performance calculations are performed for a specific design (based on Equation C. 3-7), for a specified acceptable control range $T_{v,max}$ and $T_{v,min}$, and for specified extreme sink conditions $T_{o,max}$ and $T_{o,min}$. In the event that the specified control range cannot be accommodated with a cold reservoir system (i. e., $V_r/V_{v,c} < 0$), the range of vapor temperatures is increased by a 1°C increment and this process is repeated until control can be obtained. Once the storage requirement has been determined, the maximum required condenser conductance G_{max} is calculated from Equation C. 3-10 and the parametric analysis is initiated for the minimum sink condition. At a given sink temperature, the heat transport \dot{Q} is calculated for increasing values of vapor temperature above the minimum specified value until the condenser is fully active (i. e., $\eta = 1$). The analysis is then repeated for successively increasing values of sink temperature until the specified maximum sink temperature is reached.

C.3.3 Program Description

C.3.3.1 General

A listing of the program is presented in Appendix C. The program was written in FORTRAN V and was designed to operate on the UNIVAC 1168 system. The Property Data Acquisition Code is required as a subroutine to determine working fluid vapor pressures. The FORTRAN names and the physical quantities they represent are listed in Appendix B. Storage requirements are on the order of 80,000 words (octal).

The flow diagram is included in Appendix A as an aid in the overall program logic. Input for this program is in a NAMELIST format. This allows the user to run multiple cases by changing only the variables which are different from those of the previous case. All other inputs are reinitialized as for the preceding case. The program contains options to perform either the design analysis and/or performance analysis. Basically the program reads the input data, performs the required analysis, and outputs the data.

The deck setup as shown in Figure C.3-2 consists of job control cards, the program source deck (which includes fluid property data acquisition code), additional control cards followed by the input data and program termination cards.

C.3.3.2 Input Description

The entries to be made on the various input cards are described in Table C.3-1. The NAMELIST group name, FORTRAN name, format, and units to be used are indicated for each entry. A listing of sample input data of an ammonia heat pipe, using nitrogen as the noncondensable gas, is presented in Table C.3-2 for two cases.

Table C.3-2 Sample Input Data

```
AMMONIA
NITROGEN
  CONTROL MORE=2, LIQUID=5, LCI=2, LC2=15
  DATAIN TCMAX=308.0, TCMIN=268.0, DTO=5.0, TVMAX=328.0, TVMIN=308.0,
  DTV=1.0, DQTV=1.0, RG=296.59, QMAX=6.0, VRVC=50.05
AMMONIA
NITROGEN
  CONTROL MORE=0, LCI=1, LC2=25
```

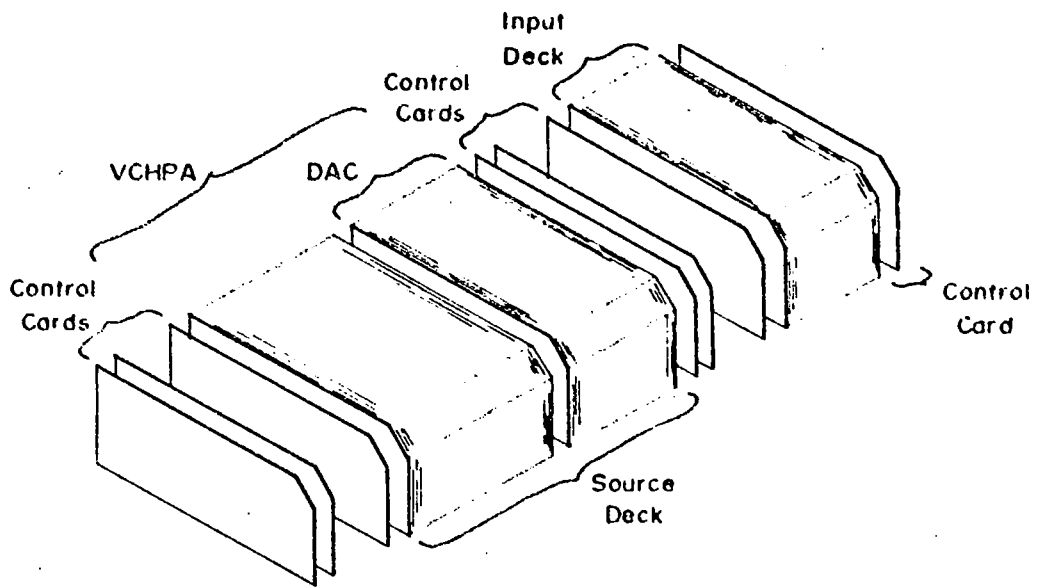



Figure C.3-1. Program Deck Setup

Table C.3-1. Input Data Description

<u>Input Card No.</u>	<u>Format</u>	<u>Fortran Name</u>	<u>Description</u>	<u>Units</u>
1	2A6	HD1 HD2	Headings (working fluid)	-
2	2A6	HD3 HD4	Headings (non-condensable gas)	-
3*	-	CONTRO	NAMelist group name	-
	integers	MORE	Control Point, integer = 0 for last case; otherwise integer = 2	-
		LC 1	Control Point, integer = 2 for both design and performance analyses; otherwise integer = 1	-
		LC 2	Control Point, integer = 2 for performance analysis; otherwise integer = 1	-
4*	-	DATAIN	NAMelist group name	-
	Floating Point	TOMAX	Maximum sink temperature	°K
	Constants	TOMIN	Minimum sink temperature	°K
		DTO	Increment of the sink temperature	°K
		TVMAX	Maximum vapor temperature	°K
		TVMIN	Minimum vapor temperature	°K
		DTV	Increment of the vapor temperature	°K
		DDTV	Operating temperature control range	°K
		RG	Gas constant of non-condensable gas	N m/kg °K
		QMAX	Maximum heat transport	W
		VRVC	Maximum allowable ratio of reservoir volume to condenser void	-

* Start with a \$ in column 2 followed immediately by NAMelist group name. New data follow and are ended with \$.

The first case requires both the design and performance analysis. In the second case, only the performance analysis is requested.

C. 3. 3. 3 Output Description

The program outputs essentially all input data. In the Design Analysis, the reservoir-to-condenser volume ratio and mass-to-condenser volume ratio are output in tabular form versus operating temperature control range ΔT_v for $T_{o, \min} \leq T_o \leq T_{o, \max}$. If the required temperature control cannot be satisfied by a particular sink temperature, the following statement will appear in the table. "RESERVOIR CAN NO LONGER PROVIDE DESIRED TEMPERATURE CONTROL". When the Performance Analysis is requested, the required reservoir-to-condenser volume ratio corresponding to the specified input is output along with the noncondensable mass-to-condenser volume ratio. This is followed by tables of the heat dissipated and the ratio of active condenser length to total condenser length versus operating vapor temperature for successive sink temperatures. If the specified vapor temperature range had to be adjusted in order to have a working cold-reservoir system, the statement "VAPOR TEMPERATURE RANGE HAS BEEN ADJUSTED" will appear before the tabular data. The storage requirements corresponding to these adjusted temperatures are calculated and used in the analysis. A listing of typical output is given in Appendix D with the sample problem.

C. 3. 3. 4 Nomenclature

The following is a listing of the nomenclature and associated symbols used in the variable conductance heat pipe analysis.

NOMENCLATURE

<u>Symbol</u>	<u>Description</u>	<u>Units</u>
A	Heat rejection area per unit length of condenser	m^2/m
G	Thermal conductance	$W/^\circ K$
h	Heat transfer coefficient	$W/^\circ K m^2$
L_a	Active length of condenser	m
m	Mass of non-condensable gas	kg
P	Pressure	N/m^2
Q	Heat transport	W
R	Gas constant of non-condensable gas	$N m/kg ^\circ K$
T	Temperature	$^\circ K$
V	Volume	m^3

Subscript:

c	Condenser
eff	Effective
g	Non-condensable gas
n	Nominal
max.	Maximum condition
min.	Minimum condition
o	Sink
r	Reservoir
v	Vapor

Appendix A. Flow Diagram
for the Variable Conductance Heat Pipe Analysis Code

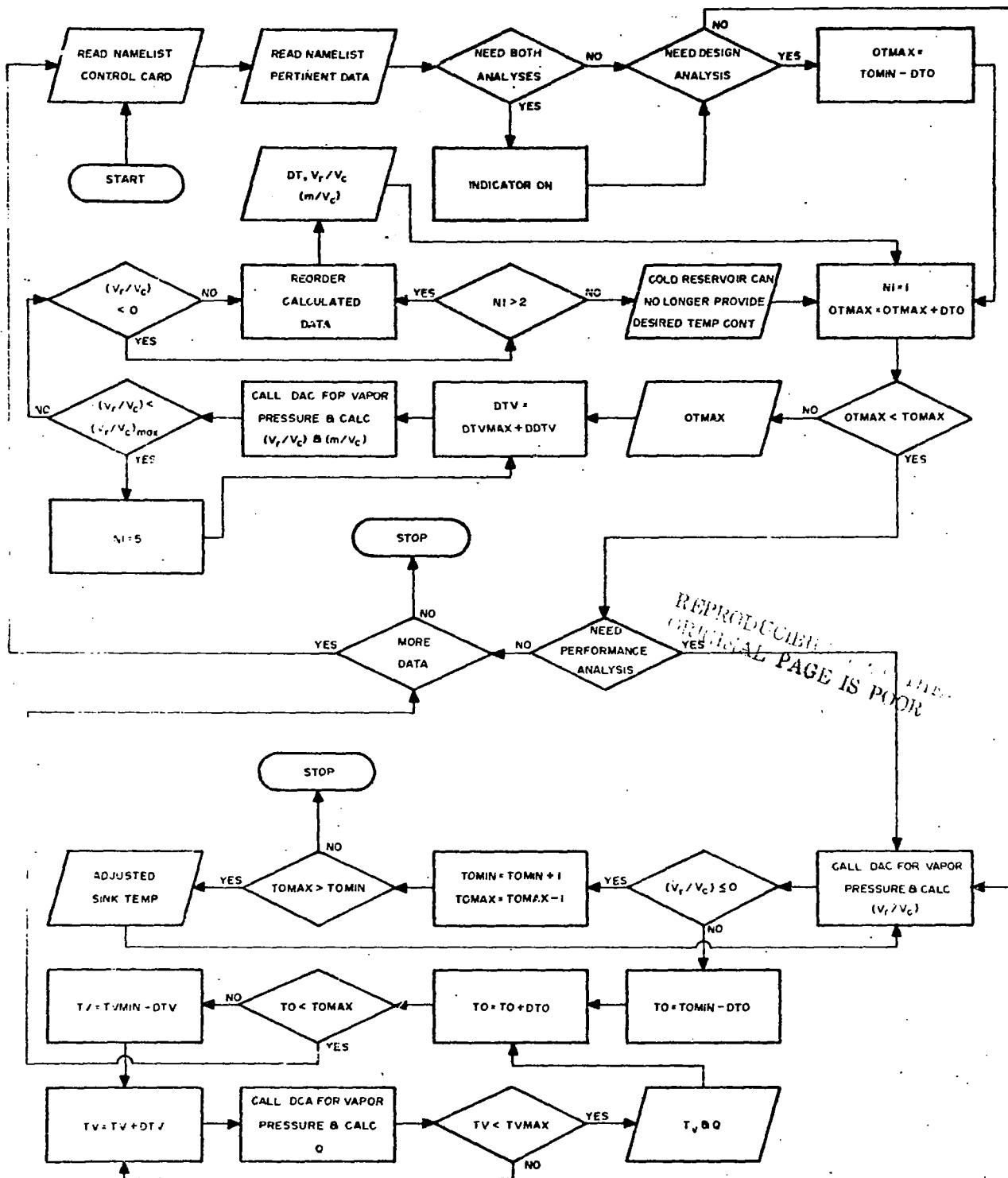

**Appendix B. FORTRAN Names
and Associated Physical or Engineering Quantities**

<u>Fortran Name</u>	<u>Description</u>	<u>Units</u>
OUT 1	Operating temperature control range (ΔT_v)	$^{\circ}\text{K}$
OUT 2	Reservoir - condenser volume ratio (V_r/V_c)	-
OUT 3	Ratio of the mass of the gas to the condenser volume (m/V_c)	kg/m^3
CONTROL	A NAMELIST group name	-
MORE	Control Point, integer = 0 for last set of data, otherwise integer = 2	-
LIQUID	Control Point, type of working fluid	-
	1 Hydrogen	
	2 Nitrogen	
	3 Oxygen	
	4 Water	
	5 Ammonia	
	6 Methanol	
	7 Acetone	
	8 Freon-21	
	9 Sodium	
	10 Potassium	
	11 Lithium	
	12 Mercury	
LC 1	Control Point, integer = 2 for both Design Analysis and Performance Analysis, otherwise integer $\neq 2$	-
LC 2	Control Point, integer = 2 for Performance Analysis only, otherwise integer $\neq 2$	-
DATAIN	A NAMELIST group name	-
TOMAX	Maximum sink temperature	$^{\circ}\text{K}$
TOMIN	Minimum sink temperature	$^{\circ}\text{K}$
DTO	Increment of the sink temperature	$^{\circ}\text{K}$
TVMAX	Maximum vapor temperature	$^{\circ}\text{K}$
TVMIN	Minimum vapor temperature	$^{\circ}\text{K}$

<u>Fortran Name</u>	<u>Description</u>	<u>Units</u>
DTV	Increment of the vapor temperature	$^{\circ}\text{K}$
DDTV	Operating temperature control range	$^{\circ}\text{K}$
RG	Gas constant of the non-condensable gas	$\text{N m/kg } ^{\circ}\text{K}$
QMAX	Maximum heat transport	W
VRVC	Maximum allowable ratio of reservoir volume to condenser vapor volume	-
HD1, HD2	Headings (working fluid)	-
HD3, HD4	Headings (non-condensable gas)	-
KOUNT	Control Point for calculations	-
LSUPP	Control Point for the Property Data Acquisition Code	-
LOUT	Control Point for the Property Data Acquisition Code	-
TVN	Nominal operating temperature	$^{\circ}\text{K}$
IND	Control Point for different analysis	$^{\circ}\text{K}$
OTMAX	Sink temperature	$^{\circ}\text{K}$
NN	Control-number of calculations	-
MM	Control-number of calculations	-
DAC	Property Data Acquisition Code	-
ARHOL* ORHOL	Liquid density	kg/m^3
ARHOV* ORHOV	Vapor density	kg/m^3
AXLAM* OXLAM	Latent heat of evaporation	W s/kg

* Data not used in this program but included as a general format for calling up the Property Data Acquisition Code.

<u>Fortran Name</u>	<u>Description</u>	<u>Units</u>
ASIGM* OSIGM	Surface tension	N/m
AXMUL* OXMUL	Dynamic liquid viscosity	kg/m s
AXMUV* OXMUV	Dynamic vapor viscosity	kg/m s
PVOMA	Vapor pressure at the maximum sink temperature	N/m ²
XMW	Molecular weight of the working fluid	kg/mole
GAMMA	Ratio of specific heats of the working fluid	-
PVOMI	Vapor pressure at the minimum sink temperature	N/m ²
VTD	Increment of vapor temperature	°K
VTMAX	Maximum vapor temperature	°K
VTMIN	Minimum vapor temperature	°K
PVMAX	Vapor pressure at the maximum vapor temperature	N/m ²
PVMIN	Vapor pressure at the minimum vapor temperature	N/m ²
VCDVR	Condenser-reservoir volume ratio	-
VRDVC	Reservoir-condenser volume ratio	-
NNN	Control-number of calculations	-
NNP	Control-number for temporary storage	-
CTVMA	Maximum vapor temperature	°K
CTVMI	Minimum vapor temperature	°K
GMAX	Maximum thermal conductance	W/°K

* Data not used in this program but included as a general format for calling up the Property Data Acquisition Code.

<u>Fortran Name</u>	<u>Description</u>	<u>Units</u>
NA	Control-number of calculations	-
NB	Control-number of calculations	-
TO	Sink temperature	^o K
KT	Counter for calculations	-
PVO	Vapor pressure at sink temperature	N/m ²
PV	Vapor pressure	N/m ²
F	Effective length	m
Q	Heat transport	W

**Appendix C. Program Listing
of the Variable Conductance Heat Pipe Analysis**

PRECEDING PAGE BLANK NOT FILMED

```

DIMENSION OUT1(50),OUT2(50),OUT3(50)
NAMELIST/CONTRO/ (MOM,LC,LC1,LC2)
NAMELIST/DATA1/(TOMAX,TMIN,DT,TVMAX,TVMIN,DTV,DTV,RG,UMAX,VRVC)
11 FORMAT (11F10.4)
12 FORMAT (////) VARIABLE CONDUCTANCE HAS BEEN ADJUSTED *
13 FORMAT (////) PIPE ANALYSIS (SEVHPA) *
14 FORMAT (////) IC D L D - W I C K E D R E S E R V O I R *
15 FORMAT (////) D E S I G N A N A L Y S I S *
16 FORMAT (////) I N P U T D A T A *
17 FORMAT (////) MAXIMUM ALLOWABLE SINK TEMPI) MINIMUM SINK TEMPI
18 (K) *
19 FORMAT (////) NOMINAL OPERATING TEMPI) MAX. OPERATING TEMPI)
20 I MIN. OPERATING TEMPI) *
21 FORMAT (////) MAXIMUM ALLOWABLE RATIO OF RESERVOIR VOLUME TO CONDENSER
22 (SER VOID) *
23 FORMAT (////) O U T P U T D A T A *
24 FORMAT (////) MAX. SINK TEMPI) (DT)VAPOR(K) (VR/V
25 (C) (M/V)(KG/M-H) *
26 FORMAT (////) RESERVOIR CAN NO LONGER PROVIDE DESIRED TEMPERATURE C
27 (ONTROL) *
28 FORMAT (////) P E R F O R M A N C E A N A L Y S I S *
29 FORMAT (////) MAXIMUM SINK TEMPI) MINIMUM SINK TEMPI) *
30 FORMAT (////) MAXIMUM HEAT TRANSPORT(W) *
31 FORMAT (////) MAX. VAPOR TEMPI) MIN. VAPOR TEMPI) *
32 FORMAT (////) VAPOR TEMPERATURE RANGE HAS BEEN ADJUSTED *
33 FORMAT (////) RATIO OF RESERVOIR VOLUME TO CONDENSER VOID *
34 FORMAT (////) RATIO OF THE MASS OF NON-CONDENSIBLE TO CONDENSER VCI
35 (D)(KG/M-H) *
36 FORMAT (////) SINK TEMPI) VAPOR TEMPI) HEAT TRANSP
37 (RT(W) ACTIVE CONDENSER LENGTH/TOTAL CONDENSER LENGTH) *
38 FORMAT (12A6)
39 FORMAT (////) 18M WORKING FLUID (2A6)
40 FORMAT (////) 24M NON-CONDENSIBLE GAS (2A6)
41 FORMAT (////) 28M GAS CONSTANT (M-H)/KG-K) (F8.3)
42 FORMAT (//F15.2,19X,F15.2)
43 FORMAT (//F19.2,7X,F19.2,7X,F19.2)
44 FORMAT (//F20.5)
45 FORMAT (//20X,F20.3,2E20.6)
46 FORMAT (//14.3,7X,F14.3)
47 FORMAT (//F16.4)
48 FORMAT (//20X,F20.3,2E20.6,20X,F10.5)
49 READ (5,10) HD1,HD2
50 READ (5,10) HD3,HD4
51 READ (5,CONTRO)
52 READ (5,DATA1)
53 KOUNT=0
54 LSUPP=2
55 LOUT=0
56 TVN=(TVMAX-TVMIN)/2.0+TVMIN
57 WRITE (6,11)
58 WRITE (6,12)
59 WRITE (6,13)
60 WRITE (6,14) HD1,HD2
61 WRITE (6,15) HD3,HD4
62 WRITE (6,16) RG
63 INQ=0
64 IF (LC1.NE.2) GO TO 17

```

```

END=1
17 IF (LC2.EQ.2) GO TO 14
WRITE (6,17)
WRITE (6,19)
WRITE (6,20)
WRITE (6,21)
WRITE (6,22) TOMAX,TOMIN
WRITE (6,23)
WRITE (6,24) TVN,TVMAX,TVMIN
WRITE (6,25)
WRITE (6,26) VRVC
DTMAX=TOMIN-DTO
NN=(TOMAX-TOMIN)/DTU+1
MM=(TVMAX-TVMIN)/DDTV+1
DO 29 I=1,NN
DTMAX=DTMAX+DTU
IF (DTMAX.GT.TOMAX) GO TO 30
CALL DAC(LIQUID,LSUPP,LOUT,DRHOL,DRHOV,DXLAM,DSIGM,DXMUL,DX
IUV,DTMAX,PVOMA,XMM,GAMMA)
IF (LOUT.GT.1) GO TO 35
CALL DAC(LIQUID,LSUPP,LOUT,DRHOL,DRHOV,DXLAM,DSIGM,DXMUL,DX
IUV,TMIN,PVOM(XMM,GAMMA)
IF (LOUT.GT.1) GO TO 35
VTD=(TVMAX-TVMIN)+DDTV
NN=0
DO 31 J=1,MM
VTD=VTD-DDTV
VTMAX=TVN+VTD/2.0
VTVN=TVN-VTD/2.0
IF (VTVN.EQ.VTMAX) GO TO 32
CALL DAC(LIQUID,LSUPP,LOUT,DRHOL,DRHOV,DXLAM,DSIGM,DXMUL,DX
IUV,VTMAX,PVMAX,XMM,GAMMA)
IF (LOUT.GT.1) GO TO 35
CALL DAC(LIQUID,LSUPP,LOUT,DRHOL,DRHOV,DXLAM,DSIGM,DXMUL,DX
IUV,VTVN,PVTVN,XMM,GAMMA)
IF (LOUT.GT.1) GO TO 35
VCDVR=(PVMAX-PVOMA)+TMIN/(IPVTVN-PVOMI)/(TOMIN+RG)
VRDVC=1.0/VCDVR
XMDVC=(1.0+VRDVC)*(PVTVN-PVOMI)/(TOMIN+RG)
OUT1(J)=VTD
OUT2(J)=VRDVC
OUT3(J)=XMDVC
IF (VRDVC.LT.0.0) GO TO 32
IF (VRDVC.GT.VRVC) GO TO 32
MM=J
31 CONTINUE
32 IF (NN.EQ.0) GO TO 99
NNP=NN/J
DO 33 K=1,NNP
STOR1=OUT1(K)
STOR2=OUT2(K)
STOR3=OUT3(K)
NP=NN+1-K
OUT1(K)=OUT1(NP)
OUT2(K)=OUT2(NP)
OUT3(K)=OUT3(NP)
OUT1(NP)=STOR1
OUT2(NP)=STOR2

```

C.3-20

ORIGINAL PAGE IS POOR

```
OUTJINP)=STOKJ
33 CONTINUE
99 WRITE (6,11)
   WRITE (6,26)
   WRITE (6,27)
   WRITE (6,28) OTMAX
   IF (NNH.NE.0) GO TO 52
   WRITE (6,53)
   GO TO 29
52 WRITE (6,34) (OUT1(11),OUT2(11),OUT3(11),11=1,NNH)
29 CONTINUE
30 IF (IND.NE.1) GO TO 35
18 WRITE (6,11)
   WRITE (6,36)
   WRITE (6,20)
   WRITE (6,121)
   WRITE (6,122) TOMAX,TOMIN
   WRITE (6,37)
   WRITE (6,24) QMAX
   CTVMA=TVMAX
   CTVMI=TVMIN
56 QMAX=QMAX/(CTVMA-TOMAX)
   CALL DAC(LIQUID,LSUPP,LOUT,ORHOL,ORHOV,DXLAM,OSIGN,DXMUL,OX
LUV,CTVMA,PVMAX,XMW,GAMMA)
   IF (LOUT.GT.1) GO TO 35
   CALL DAC(LIQUID,LSUPP,LOUT,ORHOL,ORHOV,DXLAM,OSIGN,DXMUL,OX
LUV,CTVMI,PVMIN,XMW,GAMMA)
   IF (LOUT.GT.1) GO TO 35
   CALL DAC(LIQUID,LSUPP,LOUT,ORHOL,ORHOV,DXLAM,OSIGN,DXMUL,OX
LUV,TOMAX,PVOMAX,XMW,GAMMA)
   IF (LOUT.GT.1) GO TO 35
   CALL DAC(LIQUID,LSUPP,LOUT,ORHOL,ORHOV,DXLAM,OSIGN,DXMUL,OX
LUV,TOMIN,PVOMIN,XMW,GAMMA)
   IF (LOUT.GT.1) GO TO 35
   YCDVR=(PVMAX-PVOMAX)*TOMIN/((PVMIN-PVOMI)*TOMAX)-1.0
   YRDVC=1.0/YCDVR
   IF (YRDVC.GT.0.0) GO TO 54
   CTVMA=CTVMA+1.0
   CTVMI=CTVMI-1.0
   ROUNI=Y*YUNT*1
   IF (KOUNT.GT.20) GO TO 135
   GO TO 56
135 WRITE (6,53)
   GO TO 35
54 WRITE (6,123) CTVMA,CTVMI
   XMDVC=((1.0+YRDVC)/(PVMIN-PVOMI))/(TDRIN*RG)
   IF (KOUNT.EQ.0) GO TO 253
   WRITE (6,254)
253 WRITE (6,11)
   WRITE (6,26)
   WRITE (6,38)
   WRITE (6,50) YMDVC
   WRITE (6,39)
   WRITE (6,51) XMDVC
   TG=TOMIN-DTG
   NA=((1.0+TOMIN)/DTU)+1
   DO 41 1=1,NA
```

```
NH=(CTVMA-CTVMI)/DTU+1
IU=IU+DTU
KT=0
IF (IU.GT.TOMAX) GO TO 35
CALL DAC(LIQUID,LSUPP,LOUT,ORHOL,ORHOV,DXLAM,OSIGN,DXMUL,OX
LUV,TU,PVQ,XMW,GAMMA)
IF (LOUT.GT.1) GO TO 35
WRITE (6,11)
WRITE (6,40)
WRITE (6,28) TO
TV=CTVMI-DTV
DO 141 J=1,NB
TV=TV+DTV
IF (TV.GT.CTVMA) GO TO 141
IF (TV.EQ.TO) GO TO 141
CALL DAC(LIQUID,LSUPP,LOUT,ORHOL,ORHOV,DXLAM,OSIGN,DXMUL,OX
LUV,TV,PV,XMW,GAMMA)
IF (LOUT.GT.1) GO TO 35
F=1.0+YRDVC-RG*XMDVC*TO/(PV-PVO)
Q=GMAX*F*(TV-TU)
IF (U.LT.0.0) GO TO 141
TV=TV
KT=KT+1
IF (KT.GT.6) GO TO 201
IF (F.GT.1.0) GO TO 149
141 CONTINUE
201 TV=CTVMI-DTV
DO 202 K=1,NB
TV=TV+DTV
IF (TV.GT.CTVMA) GO TO 41
IF (TV.EQ.TO) GO TO 202
CALL DAC(LIQUID,LSUPP,LOUT,ORHOL,ORHOV,DXLAM,OSIGN,DXMUL,OX
LUV,TV,PV,XMW,GAMMA)
IF (LOUT.GT.1) GO TO 35
F=1.0+YRDVC-RG*XMDVC*TO/(PV-PVO)
Q=GMAX*F*(TV-TU)
IF (U.LT.0.0) GO TO 202
IF (F.GT.1.0) GO TO 41
WRITE (6,42) TV,Q,F
202 CONTINUE
GO TO 41
149 NB=24.0*DTV
TV=TVI-6.0*DTV
DO 152 K=1,NB
TV=TV+DTV/6.0
IF (TV.EQ.TO) GO TO 152
CALL DAC(LIQUID,LSUPP,LOUT,ORHOL,ORHOV,DXLAM,OSIGN,DXMUL,OX
LUV,TV,PV,XMW,GAMMA)
IF (LOUT.GT.1) GO TO 35
F=1.0+YRDVC-RG*XMDVC*TO/(PV-PVO)
Q=LMAX*F*(TV-TU)
IF (U.LT.0.0) GO TO 152
IF (F.GT.1.0) GO TO 41
WRITE (6,42) TV,Q,F
152 CONTINUE
41 CONTINUE
35 IF (MRE.GT.1) GO TO 51
STOP
```

C3-21

Appendix D. Sample Problem

PRECEDING PAGE BLANK NOT FILMED

The sample problem consists of determining storage volume requirements (Design Analysis) for a given set of sink conditions and of predicting the performance (Performance Analysis) within the range of these sink conditions and within a maximum acceptable range of vapor temperatures. The heat pipe working fluid is ammonia at a nominal operating temperature of 45°C, and the noncondensable gas is nitrogen. The sink conditions and maximum control range are specified as:

$$T_{o, \max} = 308^{\circ}\text{K}$$

$$T_{o, \min} = 268^{\circ}\text{K}$$

$$T_{v, \max} = 328^{\circ}\text{K}$$

$$T_{v, \min} = 308^{\circ}\text{K}$$

The heat that must be dissipated at maximum conditions (i. e., $T_{v, \max}$ and $T_{o, \max}$) is specified as:

$$\dot{Q} = 6 \text{ w}$$

and the maximum allowable reservoir to condenser vapor volume ratio is:

$$\frac{V_r}{V_{v, c}} = 50$$

The calculation increments are specified as:

$$\Delta T_v = 1^{\circ}\text{C}$$

$$\Delta(\Delta T_v) = 1^{\circ}\text{C}$$

$$\Delta T_o = 10^{\circ}\text{C}$$

The associated data cards are listed in Table C.3.D-1. The resulting computer output data follow. The results are also plotted in Figures C.3.D-1 and C.3.D-2. In Figure C.3.D-1, the storage requirements are shown as a function of control sensitivity for various sink temperature ranges. As indicated in the computer printout, the cold-reservoir cannot provide control with the specified volume ratio at maximum sink

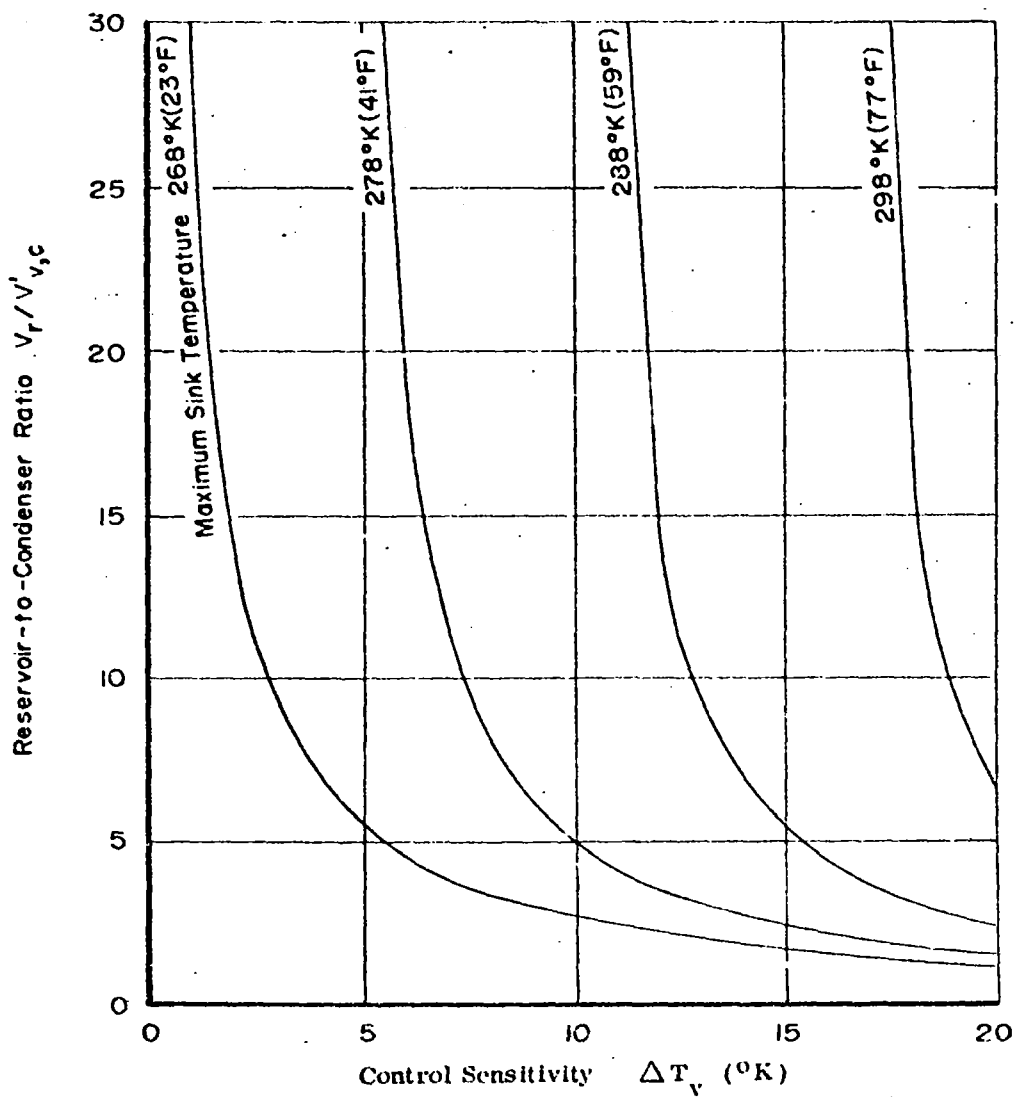

Figure C.3.D-1. Storage Reservoir Requirements as a Function of Control Sensitivity

Nominal Vapor Temperature : 318°K (113°F)
 Minimum Sink Temperature : 268°K (23°F)
 Working Fluid : Ammonia

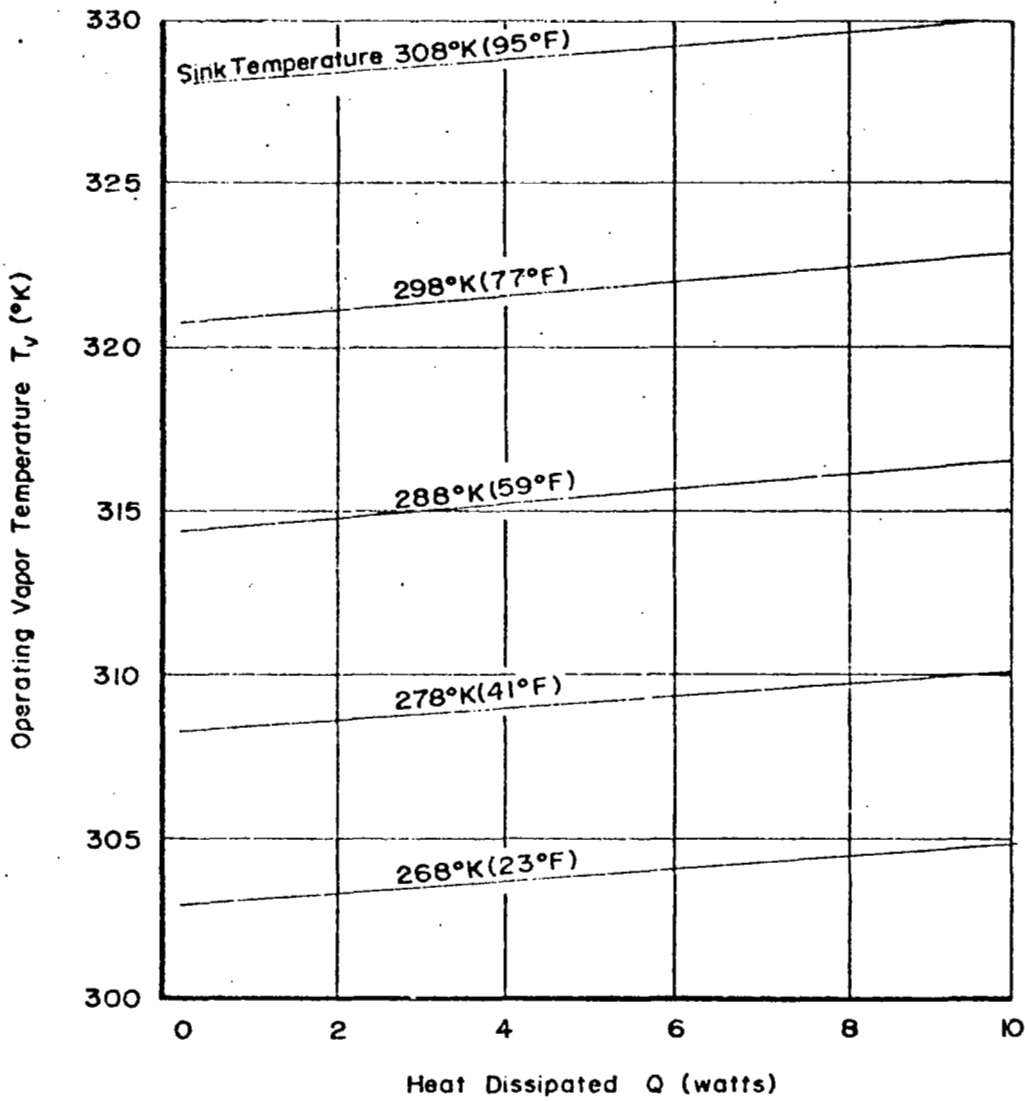

Figure C. 3. D-2. Performance Analysis: Operating Temperature Versus Heat Dissipated

Nominal Vapor Temperature : 318°K (113°F)
 Range of Sink Temperatures : 268°K - 308°K (23°F - 95°F)
 Working Fluid : Ammonia

Table C.3.D-1 List of Associated Data Cards

```
AMMONIA
NITROGEN
$CONTRO MORE=2,LIQUID=5,LC1=2,LC2=1$
$DATAIN TOMAX=308.0,TOMIN=268.0,DTO=10.0,TVMAX=328.0,TVMIN=308.0,
(DTV=1.0,DDTV=1.0,RG=296.59,QMAX=6.0,VKVC=50.0$
AMMONIA
NITROGEN
$CONTRO MORE=0,LC1=1,LC2=2$
```

temperatures above 298^oK. The results from the Performance Analysis are given in Figure C. D-2 which shows the heat pipe operating temperature T_v versus the heat dissipated Q at different sink temperatures. The allowable vapor temperature control range had to be adjusted in order to obtain control with a cold-reservoir at the specified extreme sink temperatures. This adjustment is indicated on the first page of output data for the Performance Analysis. Also, the calculation increment for the vapor temperature is adjusted internally so that at least six data points are calculated for a given sink temperature. This is to guarantee that sufficient data is available for curve plotting.

VARIABLE CONDUCTANCE HEAT PIPE ANALYSIS (VCHPA)

(COLD-WICKED RESERVOIR)

WORKING FLUID AMMONIA

NON-CONDENSIBLE GAS NITROGEN

GAS CONSTANT (N-M/KG-K) 296.590

DESIGN ANALYSIS

INPUT DATA

MAXIMUM ALLOWABLE SINK TEMP(K) MINIMUM SINK TEMP(K)

308.00

268.00

NOMINAL OPERATING TEMP(K) MAX. OPERATING TEMP(K) MIN. OPERATING TEMP(K)

318.00

328.00

308.00

MAXIMUM ALLOWABLE RATIO OF RESERVOIR VOLUME TO CONDENSER VOID

50.0000

C.3-28

PROPERTY OF
SAAB AB
POB 18

OUTPUT DATA

MAX. SINK TEMP (K) (W/VAPOR) (K) (VW/V) (M/VE) (K/M₀M₀M)

260.000

1.000	229561+02	524126+03
2.000	219810+02	526190+03
3.000	209186+01	517458+03
4.000	1999810+01	5130841+03
5.000	189759+01	5105326+03
6.000	186897+01	5080729+02
7.000	184453+01	5056290+02
8.000	182338+01	5032255+02
9.000	180475+01	5008666+02
10.000	178863+01	4985484+02
11.000	177473+01	4962634+02
12.000	176269+01	4940119+02
13.000	175207+01	4905528+02
14.000	174270+01	4875764+02
15.000	173439+01	4849872+02
16.000	172715+01	4827134+02
17.000	172099+01	4805614+02
18.000	171509+01	478536+02
19.000	170940+01	4766495+02
20.000	170383+01	4748176+02

273.000

3.000	343521+02	588272+03
4.000	353820+02	598015+03
5.000	362884+01	575806+03
6.000	372625+01	510730+03
7.000	382817+01	510397+03
8.000	394654+01	586294+02
9.000	406930+01	5737029+02
10.000	419599+01	5642039+02
11.000	429240+01	569690+02
12.000	438503+01	511215+02
13.000	448421+01	593378+02
14.000	457891+01	523500+02
15.000	468105+01	389732+02
16.000	477455+01	360758+02
17.000	486296+01	333760+02
18.000	493167+01	310633+02
19.000	498490+01	290113+02
20.000	502678+01	271967+02

RECEIVED
PAGE 15 FOUR

OUTPUT DATA

MAX. SIMK JEMP(K) (DT/VAPOR(K) (VR/VC) (M/VC) (KG/M-H-N)

278.000

6.000	.198999+02	.330951+03
7.000	.115507+02	.175125+03
8.000	.405612+01	.138902+03
9.000	.612608+01	.107197+03
10.000	.492255+01	.874927+02
11.000	.908450+01	.738069+02
12.000	.357578+01	.436233+02
13.000	.301021+01	.661739+02
14.000	.269292+01	.501707+02
15.000	.239819+01	.452929+02
16.000	.210954+01	.412589+02
17.000	.188992+01	.374563+02
18.000	.170906+01	.346068+02
19.000	.155968+01	.319904+02
22.000	.142127+01	.297202+02

283.000

8.000	.391564+02	.613698+03
9.000	.140955+02	.234039+03
10.000	.996050+01	.161825+03
11.000	.715222+01	.118306+03
12.000	.552781+01	.922272+02
13.000	.498867+01	.769078+02
14.000	.375239+01	.659396+02
15.000	.320797+01	.569231+02
16.000	.278893+01	.503540+02
17.000	.245091+01	.448293+02
18.000	.216018+01	.403696+02
19.000	.193009+01	.366918+02
20.000	.173786+01	.336049+02

OUTPUT DATA

WATER SURF TEMPER (K) (DT VAPOR (K) (VR/VG) (H/VG) (L6/H-H-M)

288.000

11.000	.327877+02	.591844+03
12.000	.157388+02	.238490+03
13.000	.947946+01	.149644+03
14.000	.692003+01	.109045+03
15.000	.534242+01	.857967+02
16.000	.432179+01	.707255+02
17.000	.357803+01	.596267+02
18.000	.303253+01	.515134+02
19.000	.261909+01	.453193+02
20.000	.229407+01	.404318+02

293.000

14.000	.447789+02	.667827+03
15.000	.162661+02	.233566+03
16.000	.970475+01	.142264+03
17.000	.674152+01	.100874+03
18.000	.511756+01	.781986+02
19.000	.409280+01	.637743+02
20.000	.338742+01	.538542+02

298.000

18.000	.172671+02	.233225+03
19.000	.944418+01	.133291+03
20.000	.661083+01	.934126+02

303.000

RESERVOIR CAN NO LONGER PROVIDE DESIRED TEMPERATURE CONTROL

308.000

RESERVOIR CAN NO LONGER PROVIDE DESIRED TEMPERATURE CONTROL

PERFORMANCE ANALYSIS

INPUT DATA

MAXIMUM SINK TEMP(K) MINIMUM SINK TEMP(K)

308.000 268.000

MAXIMUM HEAT TRANSPORT(W)

4.00

MAX. VAPOR TEMP(K) MIN. VAPOR TEMP(K)

331.000 305.000

VAPOR TEMPERATURE RANGE HAS BEEN ADJUSTED

OUTPUT DATA

RATIO OF RESERVOIR VOLUME TO CONDENSER VOID

10.9226

RATIO OF THE MASS OF NON-CONDENSIBLE TO CONDENSER VOID(KG/M³-M³)

129.9633

SINK TEMP(K)	VAPOR TEMP(K)	HEAT TRANSPORT(W)	ACTIVE CONDENSER LENGTH/TOYAL CONDENSER LENGTH
268.000			
	305.000	.115063-05	.00000
	305.500	.239149+01	.24446
	306.000	.478320+01	.48252
	306.500	.717489+01	.71438
	307.000	.956629+01	.94028

268.000

305.000

.115063-05

.00000

305.500

.239149+01

.24446

306.000

.478320+01

.48252

306.500

.717489+01

.71438

307.000

.956629+01

.94028

C3-32

SINK TEMPER	VAPOR TEMPER	HEAT TRANSPORT(W)	ACTIVE CONDENSEN LENGTH/TOTAL CONDENSEN LENGTH
273.000			
	307.500	.183898+00	.02093
	308.000	.253460+01	.27760
	308.500	.488480+01	.52747
	309.000	.723426+01	.77031
275.000			
	310.500	.191022+01	.22531
	311.000	.400869+01	.46585
	311.500	.611173+01	.69935
	312.000	.821498+01	.92645
283.000			
	313.500	.143040+01	.24242
	314.000	.402135+01	.49726
	314.500	.611568+01	.74424
	315.000	.821304+01	.98344
288.000			
	316.500	.130789+01	.17592
	317.000	.340149+01	.44962
	317.500	.549688+01	.71423
	318.000	.759387+01	.97012
293.000			
	319.500	.113547+01	.16425
	320.000	.321045+01	.45540
	320.500	.531367+01	.71672
	321.000	.708825+01	.96768
298.000			
	322.500	.942877+00	.06929
	323.000	.234439+01	.35947
	323.500	.425158+01	.63913
	324.000	.618395+01	.91176
303.000			
	326.000	.714035+00	.11907
	326.500	.261780+01	.42702
	327.000	.452657+01	.72243
308.000			
	329.500	.278605+00	.05076
	330.000	.218022+01	.37466
	330.500	.407413+01	.69911

REPRODUCIBILITY OF THE
ORIGINAL PAGE IS POOR

Computer Codes

- C1 Chi, S. V., "Mathematical Modeling of Cryogenic Heat Pipes," Final Report NASA Grant No. NGR09-005-071, Catholic University of America, September 1970
- C2 Edwards, D. K., Fleischman, G. L., and Marcus, B. D., "User's Manual for the TRW GASPIPE Program," NASA CR-114306, April 1971
- C3 Lyon, R. N., Ed., "Liquid Metals Handbook," NAVENOS P-73 (Rev.) (1952)
- C4 Schins, H. E. J., "Liquid Metals for Heat Pipes, Properties, Plots, and Data Sheets," Euratom Report EUR 3653e (1967)
- C5 Skrabek, E. A. and Bienert, W. B., "Heat Pipe Design Handbook," NASA Contract NAS9-11927, Dynatherm Corporation Report No. 72-3, August 1972
- C6 Stallings, R. D. and Collett, J. F., "Heat Pipe Design Program," Lockheed Electronics Corp., TN-675-44-00275
- C7 Wright, J. P., "Computer Program for the Design and Analysis of Heat Pipes," North American Rockwell, Space Division, Report No. SD72-SA-0001, January 1972

END

DATE

FILMED

NOV 22 1974