

LOCKHEED ELECTRONICS CO., INC.
INDUSTRIAL TECHNOLOGY DIVISION - WEST
717 NORTH CONEY AVENUE
AZUSA, CALIFORNIA 91702

NASA CR-

140305

(NASA-CR-140305) LUNAR MODULE VOICE
RECORDER Final Report (Lockheed
Electronics Co., Inc.) 35 p HC \$4.75

N74-34604

CSCI 14C

G3/07

Unclas
52710

FINAL REPORT
LUNAR MODULE VOICE RECORDER
MODIFICATION SUBMITTED UNDER CONTRACT
NO. NAS-9-13644
TO
NATIONAL AERONAUTIC SPACE ADMINISTRATION
THE LYNDON B. JOHNSON SPACE CENTER

TABLE OF CONTENTS

ABSTRACT

- 1.0 DESCRIPTION OF EQUIPMENT
- 2.0 DEVELOPMENT HISTORY
- 3.0 CONCLUSIONS
- 4.0 RECOMMENDATIONS

ABSTRACT

This report describes a modification, development, and test program which resulted in a feasibility unit suitable for use as a Voice Recorder on the Shuttle Vehicle.

A LM-DSEA recorder supplied to LEC by NASA - JSC was modified to achieve the following goals:

1. Redesign case to allow in-flight cartridge change.
2. Time code change from LM code to IRIG-B 100 pps code.
3. Delete cold plate requirements (also requires deletion of long-term thermal vacuum operation at 1×10^{-5} MMHg).
4. Implement track sequence reset during cartridge change.
5. Reduce record time per cartridge because of unavailability of LM thin-base tape.
6. Add an internal Vox key circuit to turn on/off transport and electronics with voice data input signal.

All the goals were achieved and in addition the recorder performed within specification during the Shuttle vibration environment of $11.8 G^5$ rms.

The recorder was tested at both the LM vibration level of 6 G rms and at the Shuttle level of $11.8 G^5$ rms. The modified recorder achieved the same level of flutter during vibration as the DSEA recorder prior to modification.

Improvements over the specification requirements are as follows:

	SPEC.	ACTUAL
1. Cartridge change time	1 Min.	10 Sec.
2. Weight	4 lbs.	3.03 lbs.
3. Size	113 cu. in.	107 cu. inc.
4. Power consumption	4 watts	3 watts

Manufacturing cost of the LM-DSEA cartridge is high because the flight proven design includes seventeen (17) precision moving parts and tape guidance at the record reproduce heads depends on the accuracy of the cartridge.

A modified cartridge design was proposed by LEC which could reduce the cost 50%. The major savings in cost would be realized by changing the guide roller bearings from the special .18 diameter duplex ball bearings (Approx. \$80.00 each) to standard ball bearings. (\$5.00 each)

The modified LM-DSEA recorder is capable of meeting all the requirements of NASA - JSC work statement dated January 19, 1973, and is a viable candidate for the Shuttle Voice Recorder requirement.

1.0 DESCRIPTION OF EQUIPMENT

205101

1.2 GENERAL

The Shuttle Scratch Pad Recorder (See Figure 1-1 & 1-2) is a four track voice and digital data tape recorder. It is a modified version of the Lunar Module Data Storage Electronics Assembly (LM-DSEA) manufactured by Leach Corporation, Controls Division, Azusa, California for Grumman Aircraft Engineering Corporation under NASA Contract NAS 9-1100. The Controls Division of Leach Corporation became the Industrial Technology Division-West, of Lockheed Electronics Company, Incorporated in May 1973.

1.3 PURPOSE OF EQUIPMENT

The Scratch Pad Recorder is a candidate design for the Space Shuttle voice recorder application. It provides storage of voice and time correlation data signals intermittently, or continuously, for an accumulated record time of 5.5 hours. This system is designed to operate under severe environmental conditions. Improvements in the original LM-DSEA design consist of an internal Voice Operated Switch (VOX), rapid cartridge exchange through a hinged access door, and automatic rest of relay logic on insertion of an unused cartridge.

1.4 DESCRIPTION OF EQUIPMENT

Refer to Figure 1-3 and 1-4 for illustrations of the recorder's electrical and mechanical subassemblies.

1.4.1 ELECTRONICS (See Figure 1-5)

The electronics are described in eight sections:

- Signal Conditioning Electronics
- Reference Oscillator
- Bias Oscillator
- Power Supply
- Control Logic
- Tape Motion Amplifier
- Tape Drive System
- Voice Operated Switch

205101

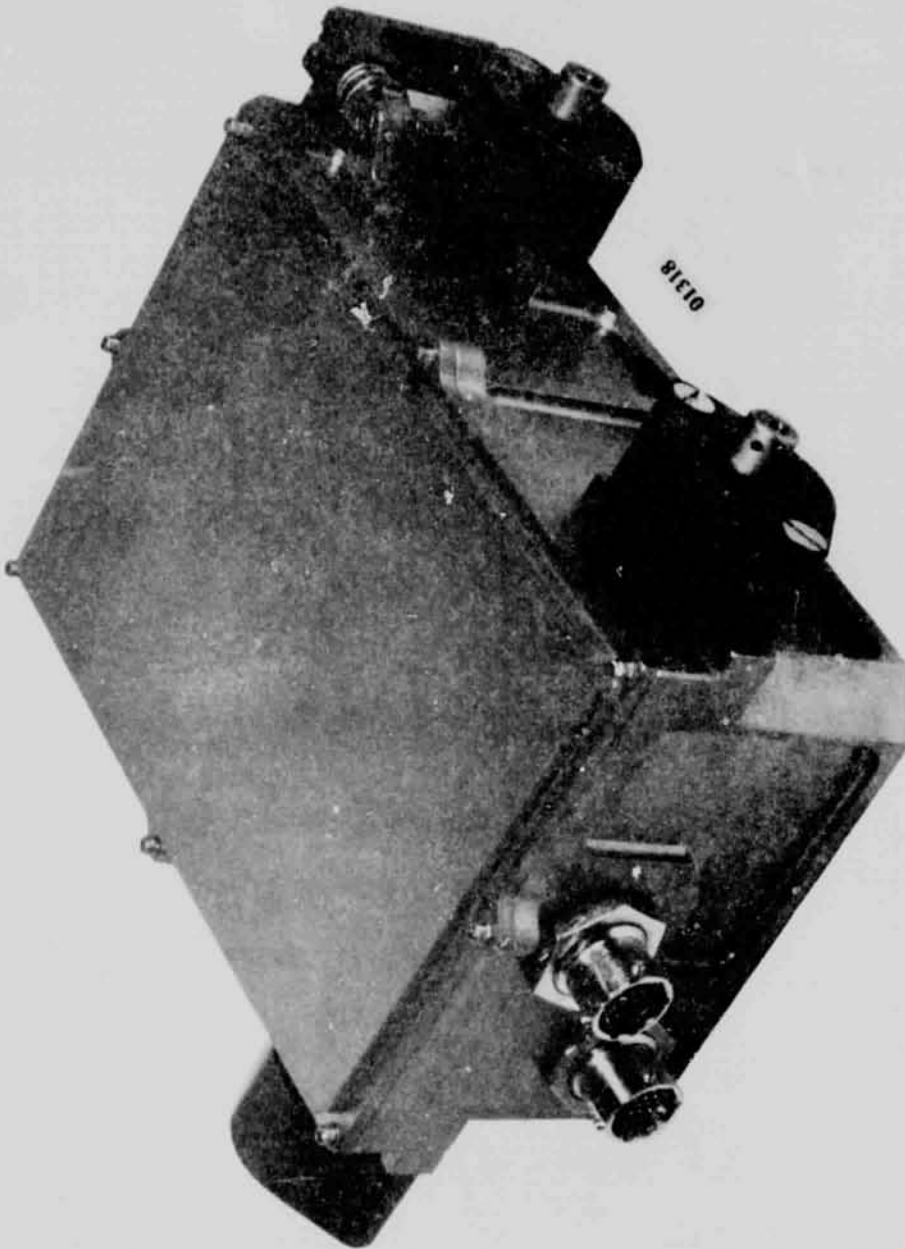

FIGURE 1-1
SHUTTLE SCRATCH PAD RECORDER

REPRODUCIBILITY OF THE
ORIGINAL PAGE IS POOR

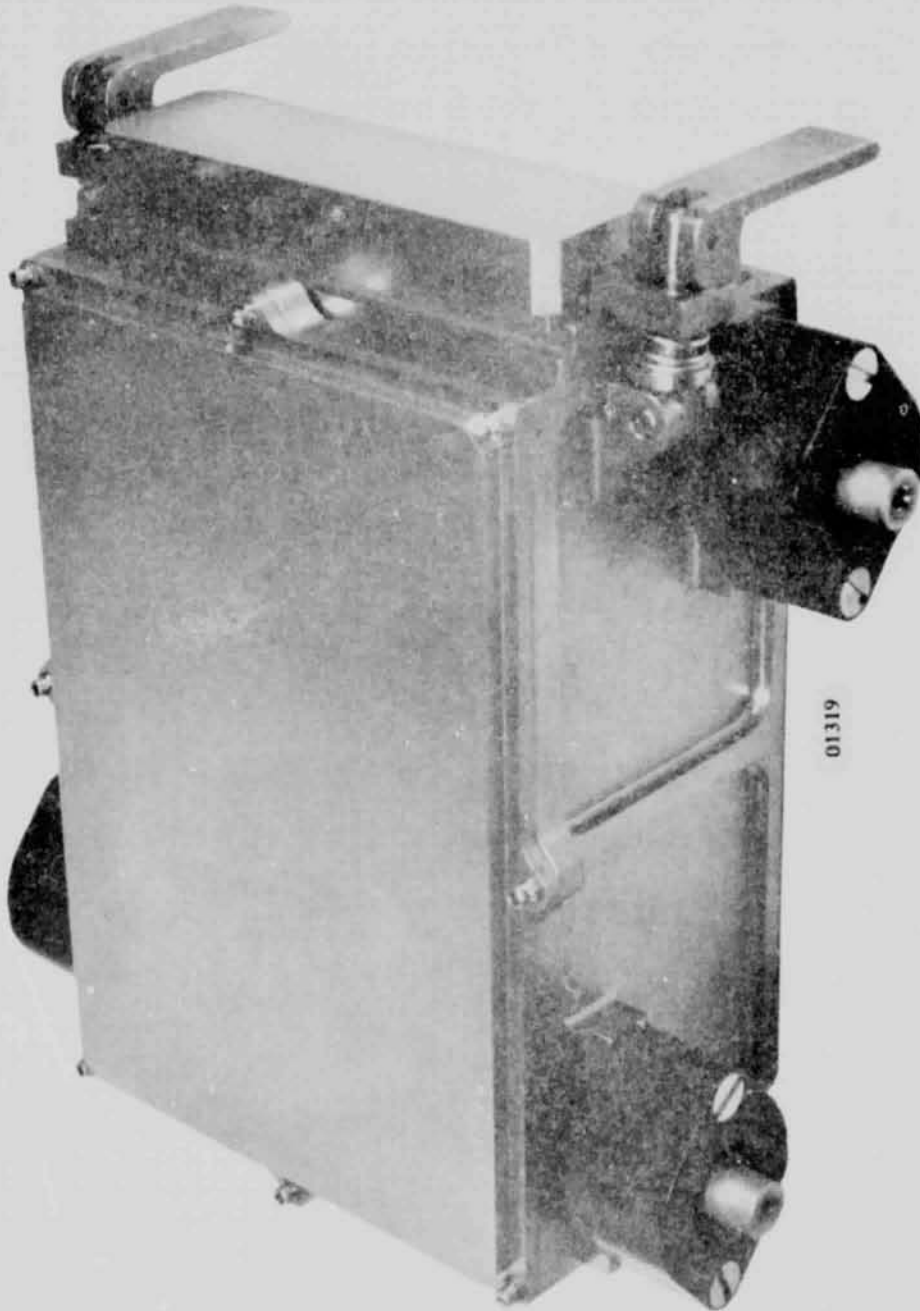
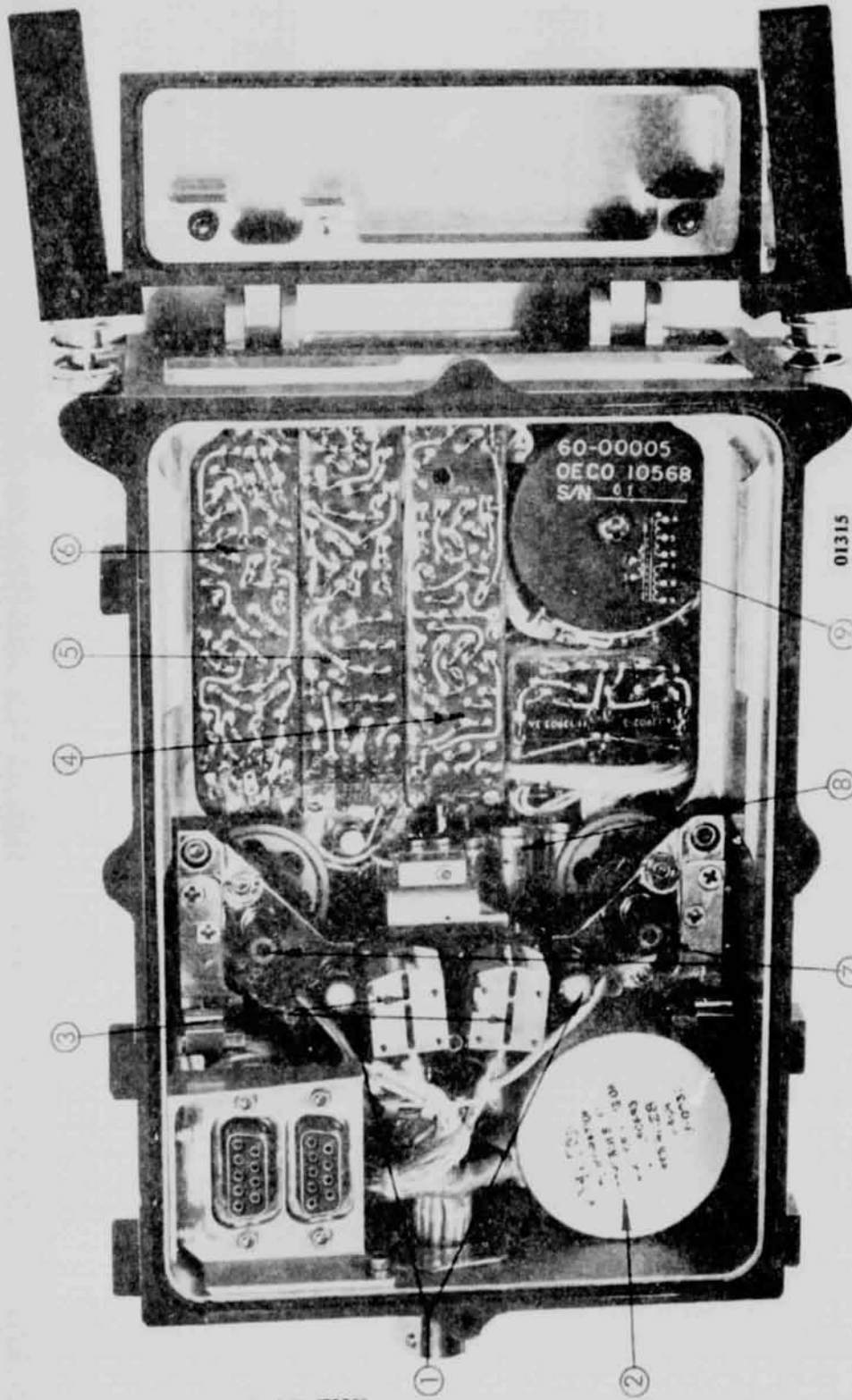

FIGURE 1-2
SHUTTLE SCRATCH PAD RECORDER

... OF THE
ORIGINAL PAGE IS POOR



REPRODUCIBILITY OF THE ORIGINAL PAGE IS POOR

- 1. End-of-Tape Sensors
- 2. Motor
- 3. Record/Reproduce Heads
- 4. Oscillator Module
- 5. Tape Motion Amplifier Module
- 6. Voice Amplifier Module
- 7. Capstans
- 8. Control Logic and Power Supply Module
- 9. Power Transformer (T1)

FIGURE 1-3
ELECTRONICS MODULES (INSTALLED)

205101

MAGAZINE



ELECTRONIC MODULES

FIGURE 1-4

01317

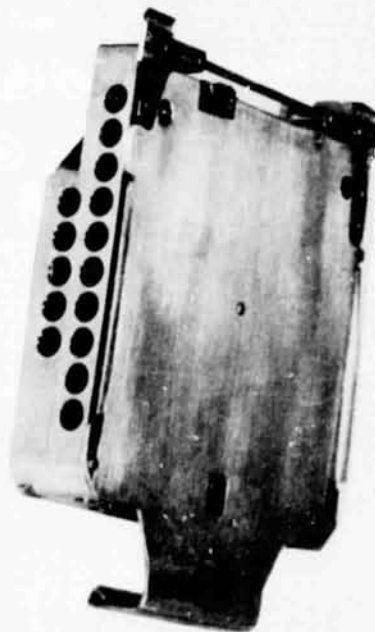

REPRODUCIBILITY OF THE ORIGINAL PAGE IS POOR

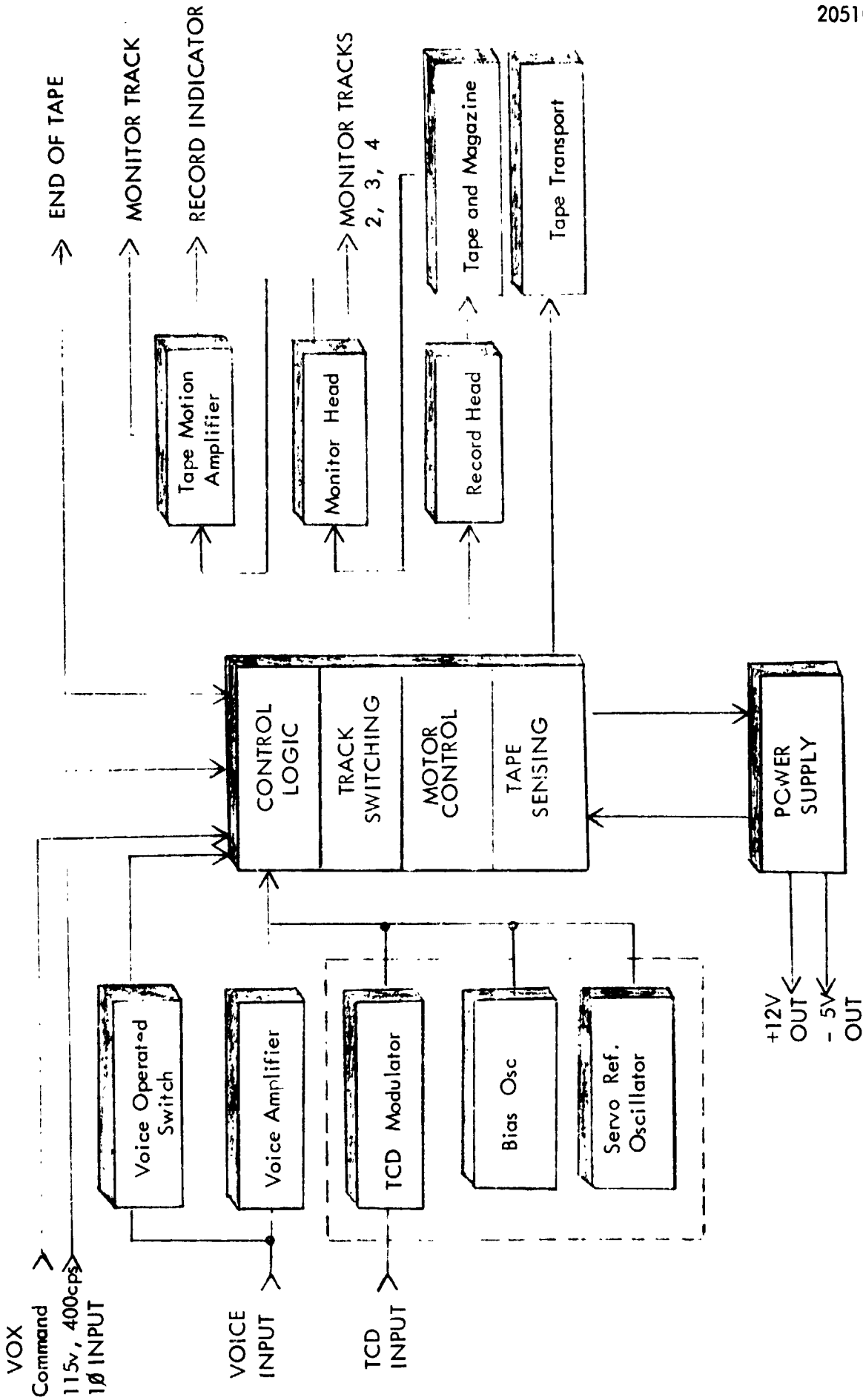

Figure 1-5
FUNCTIONAL BLOCK DIAGRAM (Simplified)

1.4.1.1 Signal Conditioning

The signal conditioning electronics accepts and conditions the audio and time correlated digital signals for application to the record head. These electronics may be divided into four circuits:

Voice Amplifier
TCD Modulator
Reference Oscillator
Bias Oscillator

Refer to Figure 1-8 for the following discussions.

1.4.1.1.1 Voice Amplifier

The voice amplifier circuit provides the bandpass filtering, signal amplification and impedance matching necessary to drive the record head at the optimum level. This circuit incorporates pre-emphasis of high frequencies. Signal compression is included to prevent overmodulation or undermodulation which normally occurs in speech patterns. The voice amplifier input is isolated from the circuitry by a 1:1 transformer, T-2. Resistor R-10 loads the primary winding to prevent low frequency distortion in the transformer and to present a constant $600 \pm 10\%$ ohms at the DSEA voice input terminals. The transformer secondary drives the AGC network composed of C-9, C-10, C-11, C-12 through R22, CR17, CR18, CR19, and Q8 through Q11. Voice compression is achieved by varying the impedance of CR17 and CR19, through changes in their junction current. Q11 supplies the current to regulate the level of compression. The compressed output is taken from the emitter of Q9 and applied to the twin tee network, composed of C13 through C16, R23 through R27, Q12 and Q13. The twin tee provides a notch attenuation at 4175 cps. The capacitance ratio of C15 and C16 controls the peaking factor of the response curve

in the 2 kc to 3 kc region. This control provides suitable pre-emphasis at the high frequencies. The resulting output of Q13 is applied to the active filter composed of C17, C18, R28, R29, R30 and Q14. This filter provides 12 db/octave attenuation from 3 kc to 4 kc. The response of the filter is ± 0.5 db to 3 kc, and at least 20 db down at 4 kc. The output of Q14 is applied to the second twin tee filter, consisting of C19 through C22, R31 through R35, Q15 and Q32. This filter provides a notch attenuation at 5.2 kc. R36 is the amplifier output GAIN adjustment. The output is coupled through C23 to the record head logic circuitry.

1.4.1.1.2 TCD Modulator

The time correlation data (TCD) modulator includes provisions for input impedance matching and modulation of the voltage controlled multivibrator, which has a bandwidth between 4000 cps and 4800 cps. The TCD modulator circuit consists of a pre-amplifier (R43, R44, R46 and Q18) which provides input impedance matching and level sensing. The output of this stage switches the frequency of the multivibrator composed of R38 through R42, C24, C25, CR20, Q16 and Q17. Resistors R39, R40 and R41 are selected to provide an output frequency of 4175 cps with a binary "1" input level and an output frequency of 4625 cps with a binary "0" input.

The output of the oscillator is applied to the emitter follower, Q19. The lowpass filter, composed of R49 and C27, prevents harmonics of the TCD and reference signal from modulating the voice signal, which could cause beat frequency interference in the voice pass-band. The TCD output is coupled through C26 and R50 to the record head logic circuitry.

1.4.1.2 Reference Oscillator

The reference oscillator is a multivibrator, consisting of R53, R54, R55, R56, C28, C29, CR22, CR23, Q21 and Q22. This oscillator supplies a 5.2 kc signal, which is recorded on the tape for subsequent use in the DSEA Test Station servo amplifier. The oscillator output is applied to the emitter follower Q20. The low-pass filter R51 and C27 is, again, used to prevent beat frequency interference in the voice passband. C26 and R50 couple the reference signal to the record head logic circuitry. VR4 provides stable biasing for the multivibrators previously described.

1.4.1.3 Bias Oscillator

The bias oscillator, composed of C30, C31, R57, R58, R59, T3 and Q23, is a "Hartley" oscillator. The frequency output is nominally 33 kc. R57 varies the output voltage level, by changing the bias on Q23. The capacitive divider, C32 and C33, couple the output to the record head logic circuitry.

The signal outputs of the audio amplifier, TCD oscillator, bias oscillator and reference oscillator are connected together at Pin 5 of relay K3. These signals are mixed, and applied to the tape, on a single track. This process allows recording of multiplexed data on each of the four tracks, consecutively.

1.4.1.4 Power Supply

The power supply provides clean, regulated dc power for all the DSEA electronics. The power supply is described in two sections:

Power Converter
Voltage Regulator

1.4.1.4.1 Power Converter

The power converter conditions the 115 V, 400 cps, which is supplied from the control logic circuit. The resulting voltage levels are +17 VDC and -8 VDC. The +17 volts operates the relays in the control logic and tape-motion monitor circuits. The +17 volts is also applied to the voltage regulator, along with the -8 volts. AC power for the capstan drive motor is supplied from a tap on the primary winding of T1.

1.4.1.4.2 Voltage Regulator

The voltage regulator accepts the +17 volts and -8 volts from the power converter and regulates these voltages to +11.5 volts and -4.5 volts, respectively. These levels are the required voltages for the DSEA electronic circuitry.

1.4.1.5 Control Logic

The main purpose of the control logic is to provide transport control and track switching for a total of four recording passes. During final checkout and preparation for flight, the DSEA is loaded with a "clean-tape" magazine. A reset command, +28 V, sets K1, K3, K4, and K5 in the position shown on the schematic diagram (i.e. track 1 forward position). The removal of the reset command leaves the DSEA ready for 5-1/2 hours of recording. Automatic reset to Track 1 is accomplished when an unused cartridge is installed in the Shuttle Scratch Pad Recorder.

An unused cartridge will have the end of tape leader across the sensor opening in a manner that when the cartridge is installed in the recorder it will contact both end of tape sensors. This signal is detected by the logic and resets itself to start recording on Track 1.

If a used cartridge is installed that does not have the end of tape leader across both sensors, the logic will not reset to Track 1 and will continue in the last operating mode before cartridge removal.

CAUTION

External power should always be removed from the recorder prior to changing cartridges. If this precaution is not observed, the transport may begin movement prior to full seating of the cartridge. The possibility of tape damage is strong.

NOTE

Each logic relay on the schematic diagram (Figure 1-8) is shown with two coils. To simplify the circuit description, the coils which are connected to pins 6 and 9 will be referred to as "upper" coils. The coils connected to pins 8 and 10 will be referred to as "bottom" coils.

The recorder is normally placed in the record mode by activation of the Voice Operated Switch (VOX), which is located in the recorder proper. Provision has also been made for an external "VOX override switch" to initiate the record command. When the record command is activated, 28 volts is applied across a parallel circuit consisting of: CR5, C6 and the "upper" coil of K2 on one side, with R5 and CR6 on the other side. C6 is charged through CR5, which provides a pulse to the "upper" coil of K2. Simultaneously, Q1 is back-biased by the voltage across R5, which prevents a false "OFF" command. This

FOLDOUT FRAME /

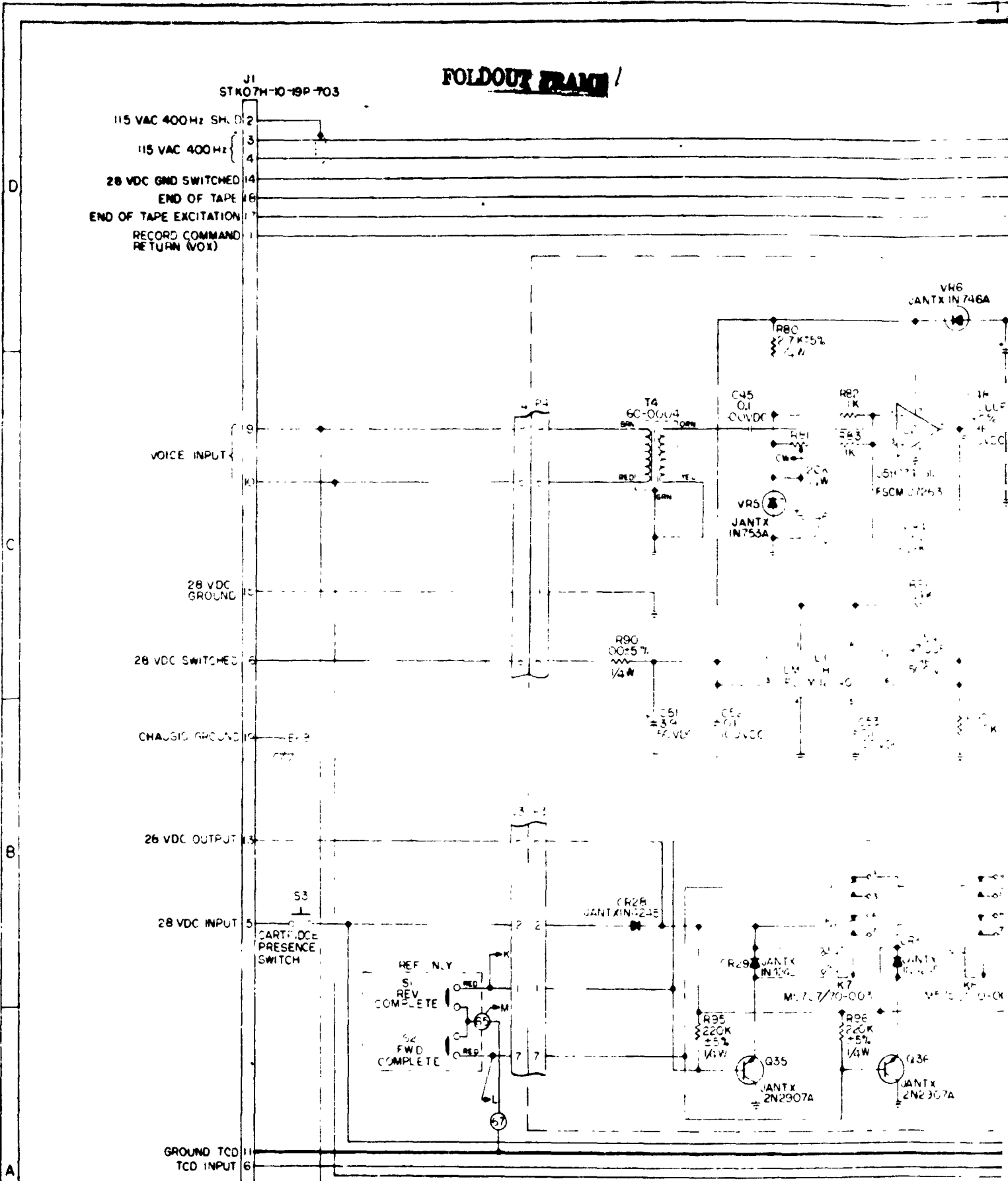

5. RELAYS ARE 60-00013 ALTERNATES ARE 60-00265 AND 60-0071-003
 4. TRANSISTORS ARE 60-00258
 3. DIODES ARE 60-00008
 2. CAPACITOR VALUES ARE IN MICROFARADS
 1. RESISTOR VALUES ARE IN OHMS ±1%, 1/8W
- NOTES UNLESS OTHERWISE SPECIFIED

REPRODUCIBILITY OF THE ORIGINAL PAGE IS POOR

6. REFERENCE DESIGNATIONS ARE ABBREVIATED, PREFIXED WITH 20A17

FRAME 3

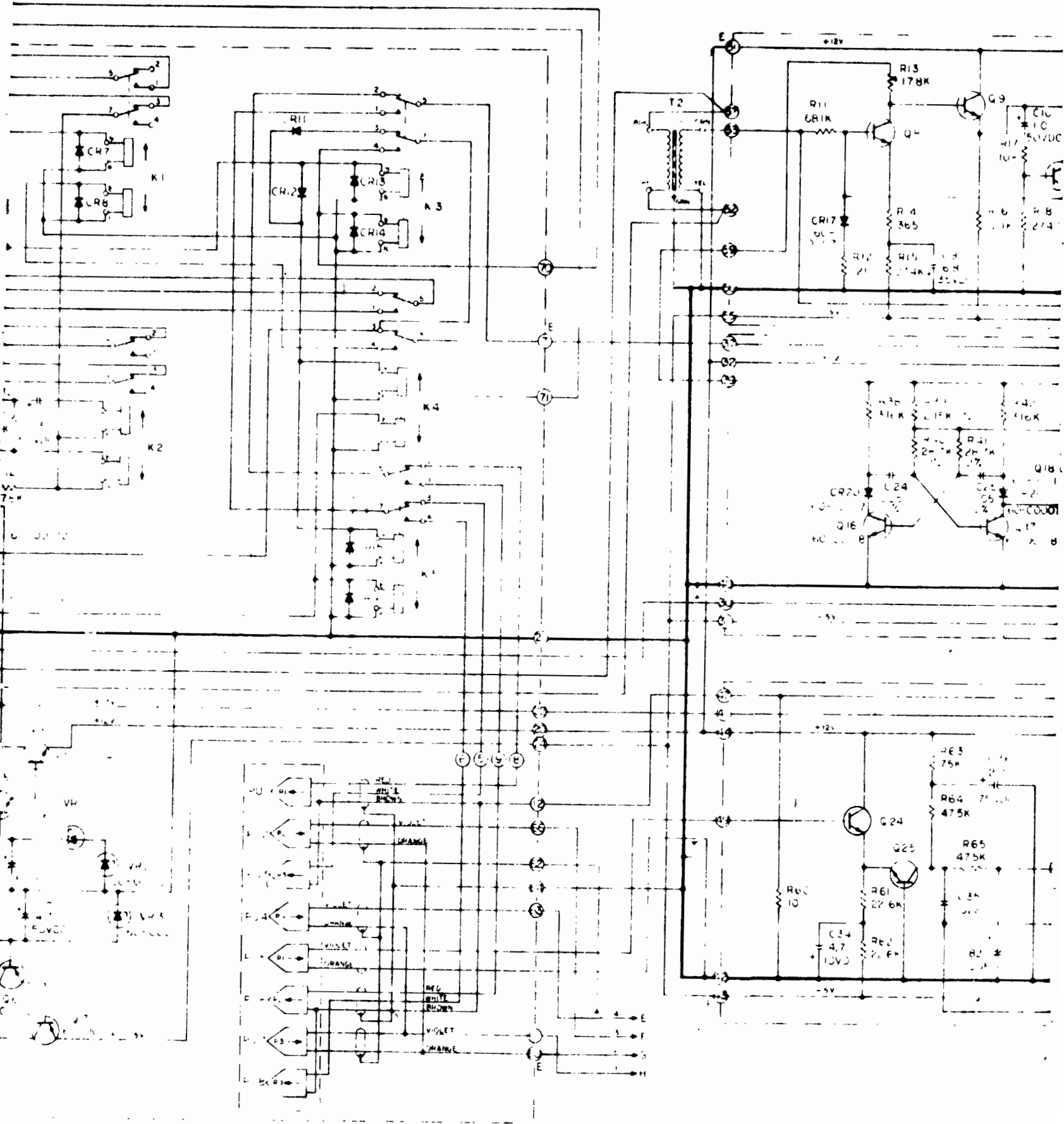

REPRODUCIBILITY OF THE ORIGINAL PAGE IS POOR

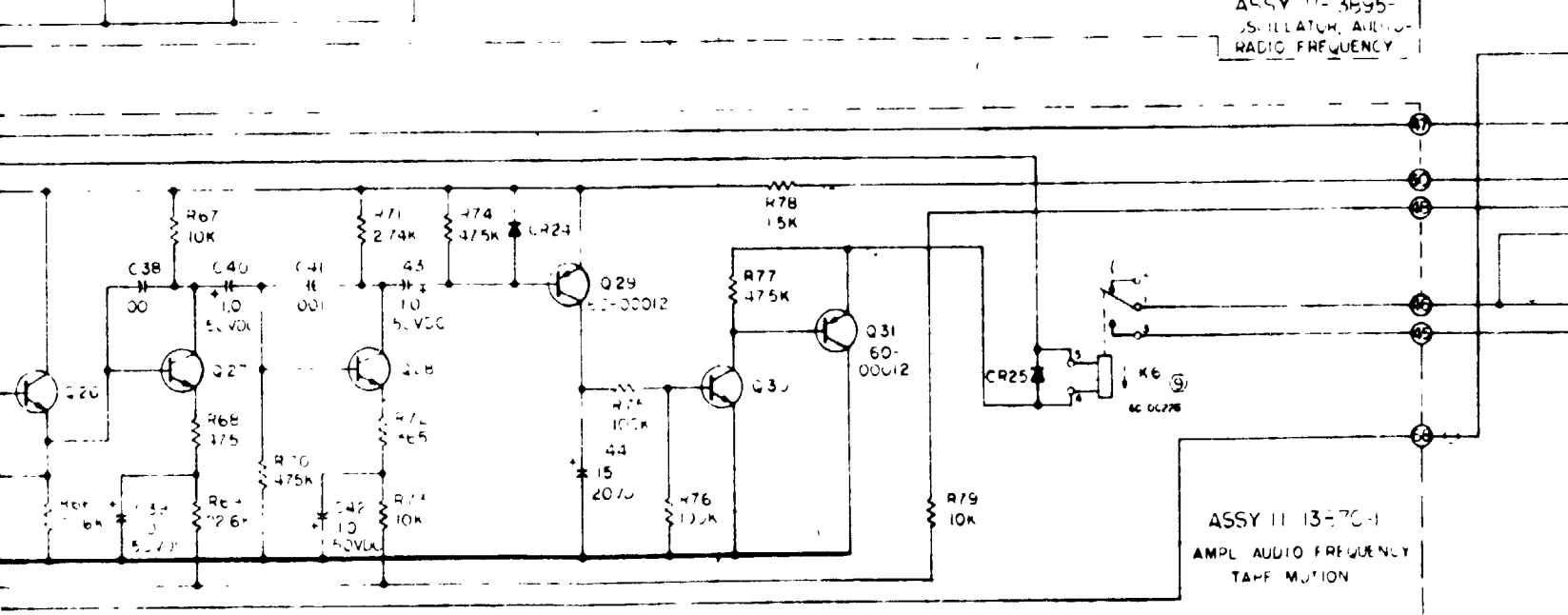
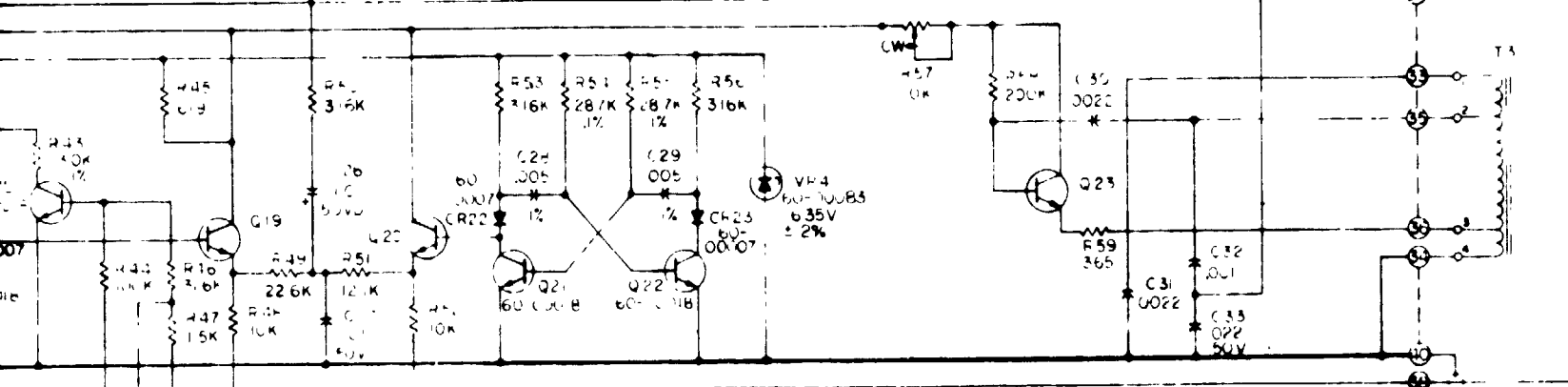
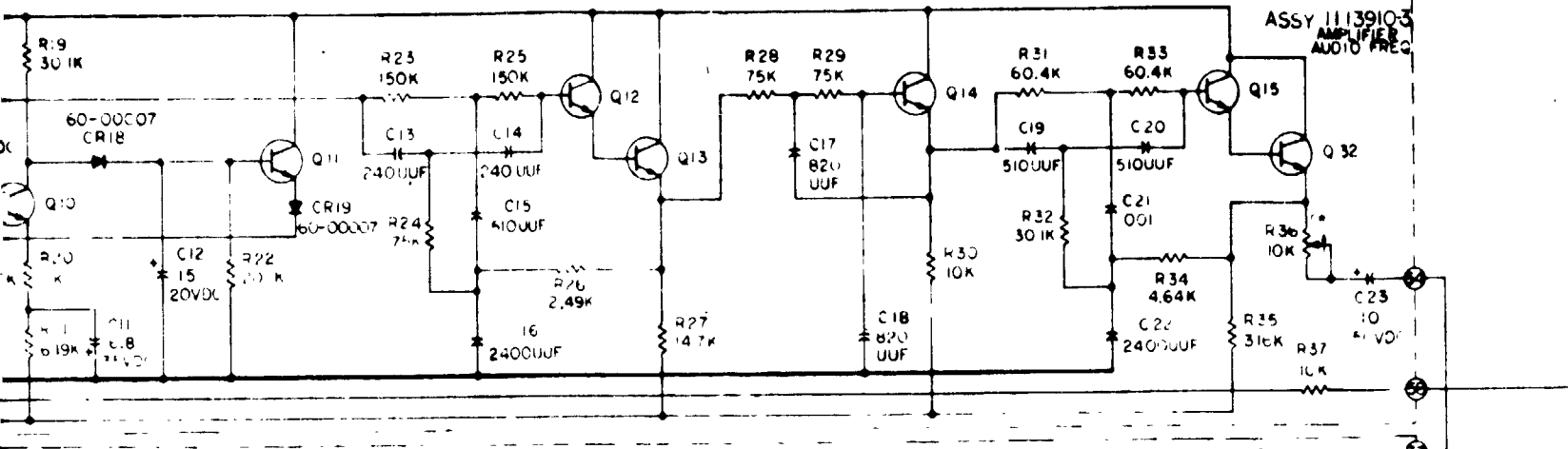

LAST REFERENCE DESIGNATION USED						
R	C	CR	Q	VR	K	T
33	55	32	31	6	0	4
REFERENCE DESIGNATION NOT USED						
R	C	CR	Q	VR	K	T
12		9-0				

action positions the K2 relay contacts as shown on the Schematic Diagram (Figure 1-8). As a result, 115 V, 400 cps power is applied to T1. When the VOX is opened, the current stored in C6 will discharge, backwards, through the "upper" coil of K2, through the "bottom" coil of K2, and through transistor Q1. This action will open the contacts of K2. The remaining logic circuitry operates from the +17 volt power, which is supplied by the DSEA power converter.

1.4.1.5.1 Track Switching (See Figure 1-6)

For the following discussion, assume that the VOX is bypassed, and the recorder has started recording on Track 1. At completion of the first pass of recording, the "FORWARD COMPLETE" the first tape sensor in the tape path comes in contact with a metallic strip located on the tape. This action completes the bias circuit for Q3. The pulse output of Q3 operates the bottom coils of relays K4 and K5. Thus, the contacts of K4 and K5 are positioned opposite that shown on the schematic. K4 changes motor direction, while K5 switches the record signal to Track 2 in preparation for the second pass (REVERSE DIRECTION) recording. When the second pass is completed, the metallic strip on the opposite end of the tape contacts the tape sensor. This completes the bias path for Q2. The output of Q2 operates the upper coils of relays K4 and K5 and the bottom coil of relay K3. The contacts of K4 and K5 are returned to the position shown on the schematic, while the contacts of K3 are placed in the opposite position shown on the schematic. K4, again, changes motor direction. The combination of K3 and K5 change the record signal to Track 3 for the third pass (FORWARD DIRECTION) recording. At the completion of Track 3, the tape sensor is shorted. This completes the bias for Q3. The output of Q3 operates the bottom coils of K4 and K5. The contacts are positioned opposite to that shown on the schematic. K4 provides motor reversing, while K5 switches the record signal to Track 4 for the fourth pass (REVERSE DIRECTION)

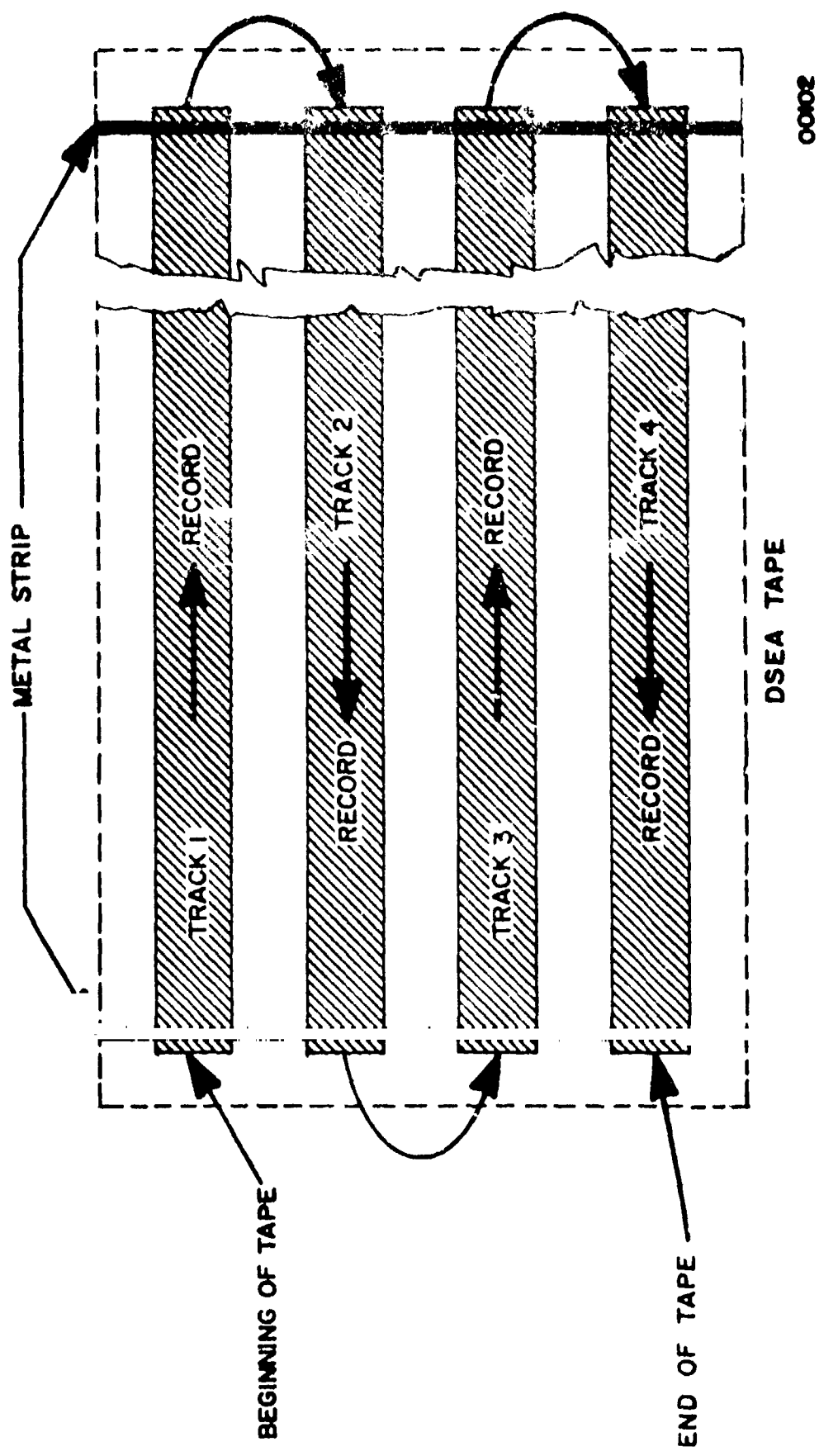

FIGURE 1 - 6
TAPE TRACK RECORDING FORMAT

recording. At the end of the fourth pass the tape sensor is shorted, thus completing the bias path for Q2. The output of Q2 is applied to the bottom coil of relay K1, through the contacts of K3 and K4. The contacts of K1 are positioned opposite to that shown on the schematic. The transfer of K1 disables the VOX circuit to interlock the recorder in the "OFF" mode. All subsequent "ON" commands will not operate the recorder until reset command is applied or a fresh cartridge is inserted with its metallic foil leader exposed over the entire front of the cartridge.

1.4.1.5.2 Tape Motion Amplifier

The tape motion amplifier receives a signal from the reproduce head while the recorder is operating. This signal is applied to the base of emitter follower Q24. The signal is then amplified and filtered by the remaining stages, so that the output of Q31 is derived from signals in the 300 to 3000 cps range. Relay K6 is driven by the output and in turn operates a record indicator external to the recorder.

1.4.1.6 Tape Drive System

1.4.1.6.1 Capstan Drive Operation

Tape motion in the recorder is initiated with the application of 26.5 VAC, 400 cps to the capstan drive motor. Transfer of power from the motor to the capstan drive system is accomplished by use of a mylar belt. The drive system consists of two identical capstans mechanically coupled. These capstan drivers, one at either end of the record/reproduce head stack, provide the rotational power necessary to move the tape over the heads. A pulley is employed at the base of each capstan and a pulley belt provides the necessary coupling between them.

1.4.1.6.2 Tape Cartridge Operation

The magazine uses a neg'ator spring drive principle to maintain uniform tape tension (See Figure 1-7). Two neg'ator springs are mounted within

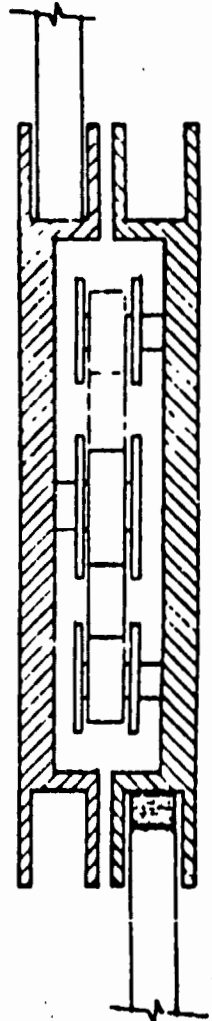
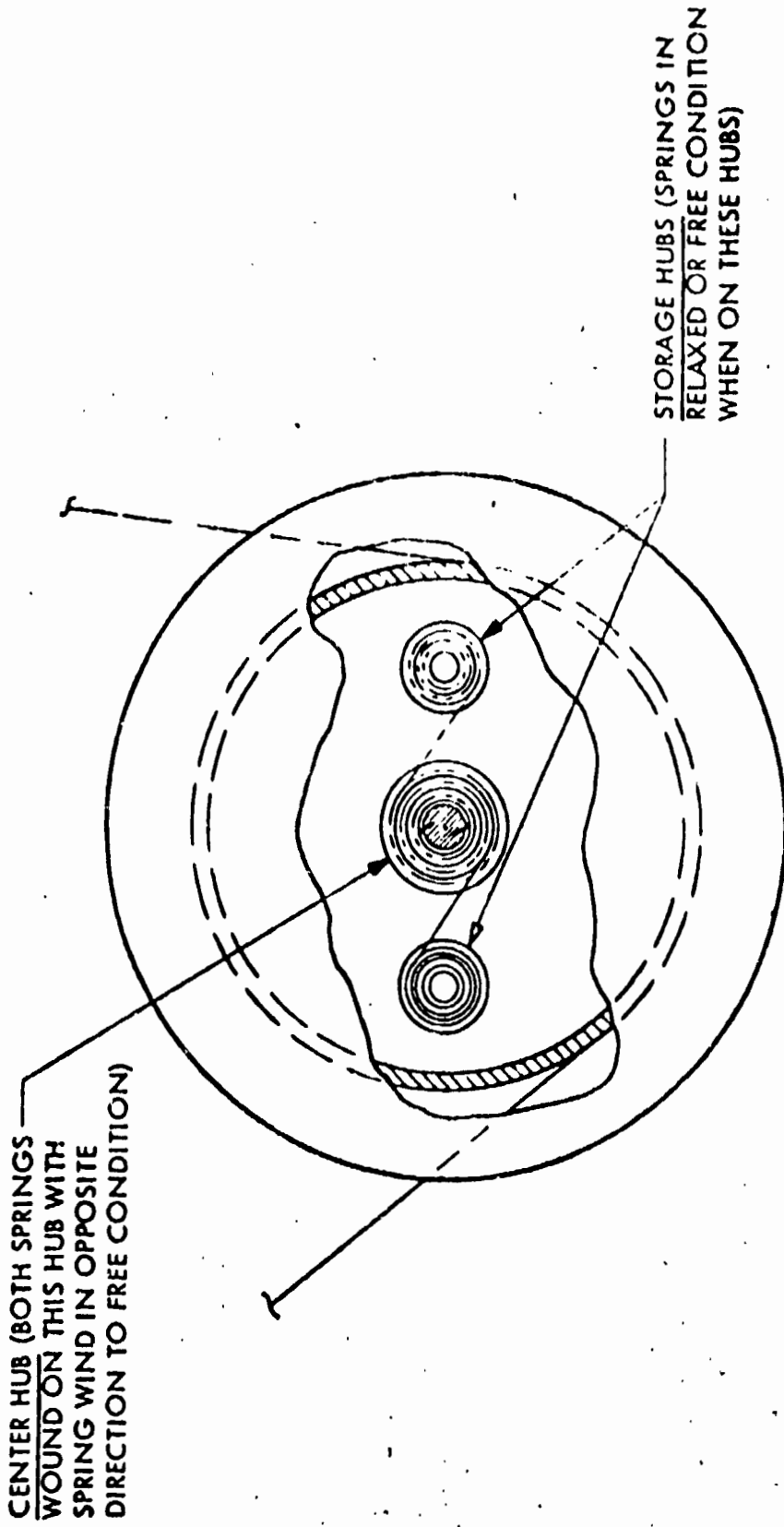

FIGURE 1-7. TAPE TENSIONING CONFIGURATION USING NEG'ATOR SPRING

the hub of the lower reel, while attached to the upper reel are the spring supply hubs. The number of wraps of the spring required on the center hub is the difference between the number of turns the two tape reels will make as half the tape between reels is used.

Application of power to the capstan motor moves the tape through the assembly as follows: As it leaves the supply reel, the tape indents and encounters approximately 180° of tape wrap around the first capstan. Sufficient capstan driving friction is achieved as a result of the high angle of tape wrap. The tape then moves across the record/reproduce heads where optimum contact pressure is maintained. Another 180° tape wrap occurs at the second capstan before the tape enters the take up reel. The tape then twists slightly at the side of the magazine and angles downward as it crosses the back of the magazine to perform a level change onto the take up reel.

At the start of the tape pass, the take up reel is revolving faster than the supply reel, and the neg'ator spring is unwinding off the center hub and onto the storage hubs. When the center of the tape is reached, both reels are revolving at the same speed. At this point, the take up reel has revolved 35 more times than the supply reel. The spring has then wound 35 turns onto the storage drum, leaving only a few turns on the center hub. At this point, the supply reel begins to revolve faster than the take up reel and will have revolved 35 more times than the take up reel while the tape is moving from its center to the end. The neg'ator spring is now wound back onto the center hub as it was at the beginning of the pass. While the magazine is out of the recorder, a brake mechanism prevents the tape reels from rotating.

1.4.1.6.3 Drive Motor

The motor is a single phase, 400 cycle, hysteresis synchronous type. Tape speed is maintained constant by coupling the capstan drivers to the motor shaft with the mylar belt. The speed of the motor is constant within $\pm 0.1\%$ of the driving power frequency. The motor produces about 0.12 inch/ounces of torque at 3,000 rpm.

1.4.1.7 Voice Operated Switch

The VOX circuit is powered by the +28 VDC line which is reduced to +12 VDC by a fixed voltage regulator (U1). The +12 VDC is used to power the input OP amp (U2), this is further reduced through VR6 to +9 VDC to power the two C/MOS chips U3 and U4.

The voice input is isolated from the VOX circuit through transformer T4 and then amplified by U2. The output of U2 is rectified by CR26 and CR27 which applies a +dc level to the reset input of U4. The input sensitivity of U2 is adjustable by R81 from 50 MV rms to 1.2Vrms nominal input at 1 kHz.

U3 is a quad dual input nand gate. Two of the gates along with C50, R93, and R94 form an oscillator circuit. The frequency is adjustable by R94. The oscillator output is applied to the input of U4 which is a 14 stage binary counter. The last stage of U4 is applied through one gate of U3 to the base of Q33 and also through a gate of U3 to the oscillator circuit. When the counter is full, the output signal inhibits the oscillator and also turns Q33 and Q34 off.

As long as there is signal at the input, the counter will remain reset to zero, and the dropout time of the VOX is varied by changing the frequency of the oscillator circuit (R94). The VOX dropout time is variable over the range of 1 to 7 seconds.

1.5 REFERENCE PUBLICATIONS

The following documents provide supplementary information regarding the Shuttle Scratch Pad Recorder.

- a. The Grumman Specification Number LSP-360-12 entitled:

"DATA STORAGE ELECTRONICS ASSEMBLY INSTRUMENTATION
SUBSYSTEM DESIGN CONTROL SPECIFICATION FOR"
- b. LEM DSEA and Test Station Preliminary Design Report -
No. 108 - 001.

1.6 LEADING PARTICULARS (See Table 1-1)

Table 1-1 lists the performance characteristics of the Shuttle Scratch Pad Recorder, Part Number 205C-1.

1.7 SPECIAL TOOLS AND TEST EQUIPMENT REQUIRED

1.7.1 TEST EQUIPMENT

The "DSEA" Test Station (TS) will be used to accomplish maintenance and testing of the Scratch Pad Recorder. Refer to Section II - Operating and Emergency Procedures for detailed information concerning the operation of the TS.

TABLE 1-1 LEADING PARTICULARS

<u>ITEM</u>	<u>CHARACTERISTICS</u>
PHYSICAL SPECIFICATIONS:	
Width	5.5 inches
Length	8.0 inches
Height	3.0 inches
Weight	3.5 pounds
POWER REQUIREMENTS:	
Power Supply Input	115 \pm 2.5 volts rms, 400 cps, 1 phase
Reset Command	28 \pm 4 volts DC
VOX input	28 + 4, -8 volts DC
MAGNETIC HEADS:	
Record/Reproduce Head	2 Heads to provide 4 tracks
VOICE RECORD AMPLIFIER:	
Input Level	-3 to +7 dbm
Frequency Response	\pm .5db from 300 to 2,000 cps +5 db preemphasis at 3 kc
Input Impedance	600 \pm 10% ohms
TCD:	
Serial Input Level	"1" bit = 6 \pm 1V peak; "0" bit = -.5V to +1.5V peak
Input Impedance	Greater than 20K ohms
Serial Input Bit Rate	100 Bits per second

TABLE 1-1 LEADING PARTICULARS (Continued)

<u>ITEM</u>	<u>CHARACTERISTICS</u>
BIAS OSCILLATOR :	
Output Frequency	$33 \pm 10\%$ kc
Output Level	5 ± 1 ma
POWER SUPPLY:	
Input	115 VAC, 400 cps, 1 phase
Output	+17 VDC unregulated +11.5 VDC regulated -4.5 VDC regulated 26 V rms
FLUTTER:	Less than 3% peak-to-peak
TAPE SPED:	0.6 ips
TOTAL RECORDING TIME:	5.5 Hours minimum
LENGTH OF TAPE BETWEEN SENSOR STRIPS:	253 Feet minimum

2. DEVELOPMENT HISTORY

The primary goal in the modification of the Lunar Module Recorder was ease of cartridge replacement. This was accomplished by employing a door on the front of the housing which allowed for straight line loading of the cartridge (see Figure 2.1) Quick acting latches were designed which made it possible to change cartridges in less than ten seconds.

The cartridge was modified by adding pins in the front and wedges at the rear for support when installed in the housing. A handle was added to the cartridge for convenience.

Automatic reset to track one was provided in the cartridge by employing a metallic leader on the tape which contacts both the B.O. T. and E.O.T. sensors on a new cartridge. Exposure of the long leader can only be accomplished by manually winding the tape to the leader.

The weight and size of the modified Lunar Module Recorder was minimized by attaching the added electronic card to the cover. This approach resulted in the most effective design since the existing wiring and input and output connectors could be used.

Performance of the recorder during vibration was considered the greatest design challenge. To establish a base line for performance the unmodified recorder was tested during vibration to the requirements of Lunar Module acceptance test specification. The recorder demonstrated 8% PP flutter maximum when hard mounted.

A decision was made to test the modified recorder both hard mounted and with vibration isolators. This decision was made because the Shuttle vibration level was expected to be greater than the lunar module vibration requirement and acceptable flutter levels could only be achieved by reducing the energy reaching the recorder.

Results of vibration testing verified that isolators are necessary to achieve acceptable performance during the shuttle environment.

Some problems were experienced during vibration testing and a modification to the cartridge hold down technique was implemented.

REPRODUCIBILITY OF THE
ORIGINAL PAGE IS POOR

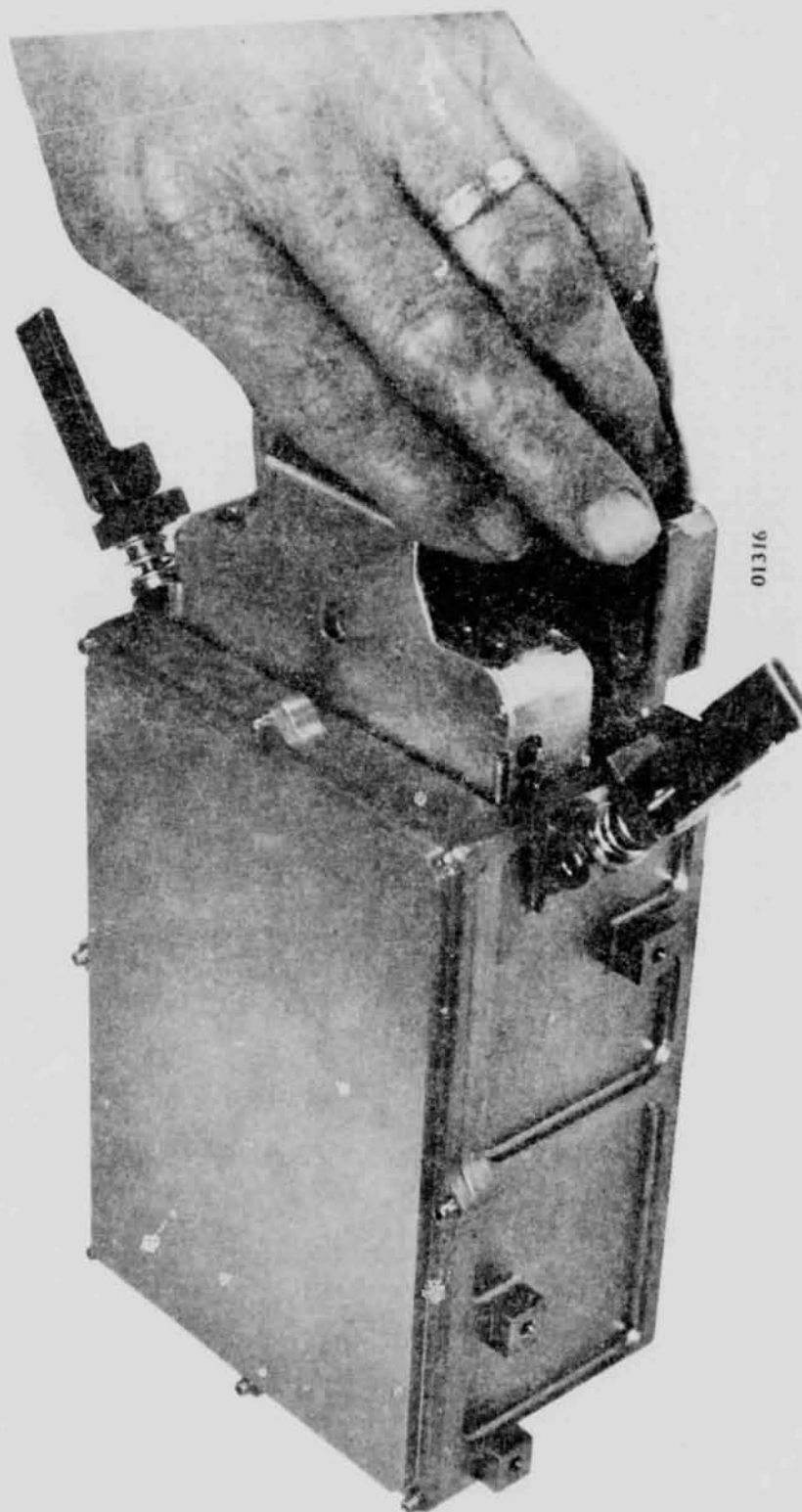

FIGURE 2.1
MAGAZINE LOADING

2. Continued

High flutter was experienced in the vertical axis of vibration when the recorder was hard mounted. The cause was determined to be flexure of the forward end of the cartridge housing.

It was determined that support of the cartridge housing should be relocated to the same position as on the DSEA cartridge hold down screws. See Figure 2.2.

It was necessary to use tapered pins in place of straight pins because space was limited in the area available for mounting the cartridge.

Flutter during the shuttle vibration level of 11.8 G^s rms was 30% P to P hard mounted, and 3% P to P when mounted on isolators.

A summary of specifications and performance results is shown on Table 1.

Electronic changes included the addition of an interval voice operated switch (VOX) and automatic reset of relay logic to track (1) when a new cartridge is installed. A voltage regulator was also added to supply power for the VOX circuit.

The enclosure contains an O. ring seal on the cartridge access door and electronics access cover. The internal atmosphere in the recorder will be the same as the surrounding atmosphere since installation of the cartridge allows entry of the external atmosphere.

The use of dessicent inside the housing may be desirable.

Acceptance testing was conducted at LEC ITD-West during the week of May 6, 1974.

All the requirements were met except for digital error rate. The cause for errors was determined to be caused by changing to a different tape. The Ampex Tape formerly used is no longer available so 3M 551 and 3M 990 tape was tested in the modified recorder, and the electronics are not set up to be compatible with the 3M tape.

The electronics were adjusted to improve the error rate, however, since a cartridge modification program is anticipated which could result in the selection of another type of tape no further effort was expended.

3.0 CONCLUSIONS:

1. The lunar module voice recorder as modified performs within specification during the Shuttle vibration environment.
2. Ease of cartridge replacement has been demonstrated successfully. Replacement time is approximately 10 seconds.
3. Manufacturing cost of the cartridge is the major problem area. The original cartridge design stressed light weight and small size without considering the impact on cost. No effort has been expended to date in cost reduction of the cartridge.

A proposal was submitted to NASA in January, '74 which described areas in the cartridge which can be cost reduced.

The cartridge can be reduced in cost but the recorder demands accurate tape tracking. The precision required by the Lunar Module voice recorder does not lend itself to what might be termed an inexpensive cartridge.

4.0 RECOMMENDATIONS:

1. Design and test a cost effective cartridge as Phase II of the Lunar Module voice recorder modification contract. A substantial savings can be realized by simplifying the guide rollers and housing design.

SPECIFICATION AND PERFORMANCE
COMPARISON

	LUNAR MODULE RECORDER	MODIFIED LM RECORDER
Transport Type	Coaxial Reel	Same
Reels	3.59 Dia.	Same
Type tension system	Negator spring	Same
Guide rollers	13 duplex assemblies (.18 dia.)	Same
Bearings	Duplex	Same
Lubrication	NPT3 oil	Same
Tape	AMPEX	3M 551 or 3M990 1 MIL .5 MIL
Record Time	10 Hrs.	5.75 hr. 9.75 hr. 256.5 Ft. 460 Ft.
End of tape sensing	Conductive Leader	Same
Track reset	Manual	Conductive Leader & Manual
Power Input	115 V _{ac} 400 Hz & +28vdc	Same
Power Consumption	Less then 3 watts	Same
Size	2.05 x 4.0 x 6.22	2.75 x 5.37 x 7.25 (107 cu. in.)
Weight - Recorder	2 lb. 6 oz.	3.03 lbs
Weight - Cartridge	.39 lbs.	.437 lbs.
Tape speed	.6 IPS	Same
Flutter - bench	2%	Same
Flutter - during vibration		
6 G RMS hard mounted	8% P. P.	Same
6 G RMS isolated	NA	2% P. P.
11.8 G RMS Hard mounted	NA	30% P. P.
11.8 G RMS isolated	NA	3% P. P.
Seal	Hermetic - O - ring	Same

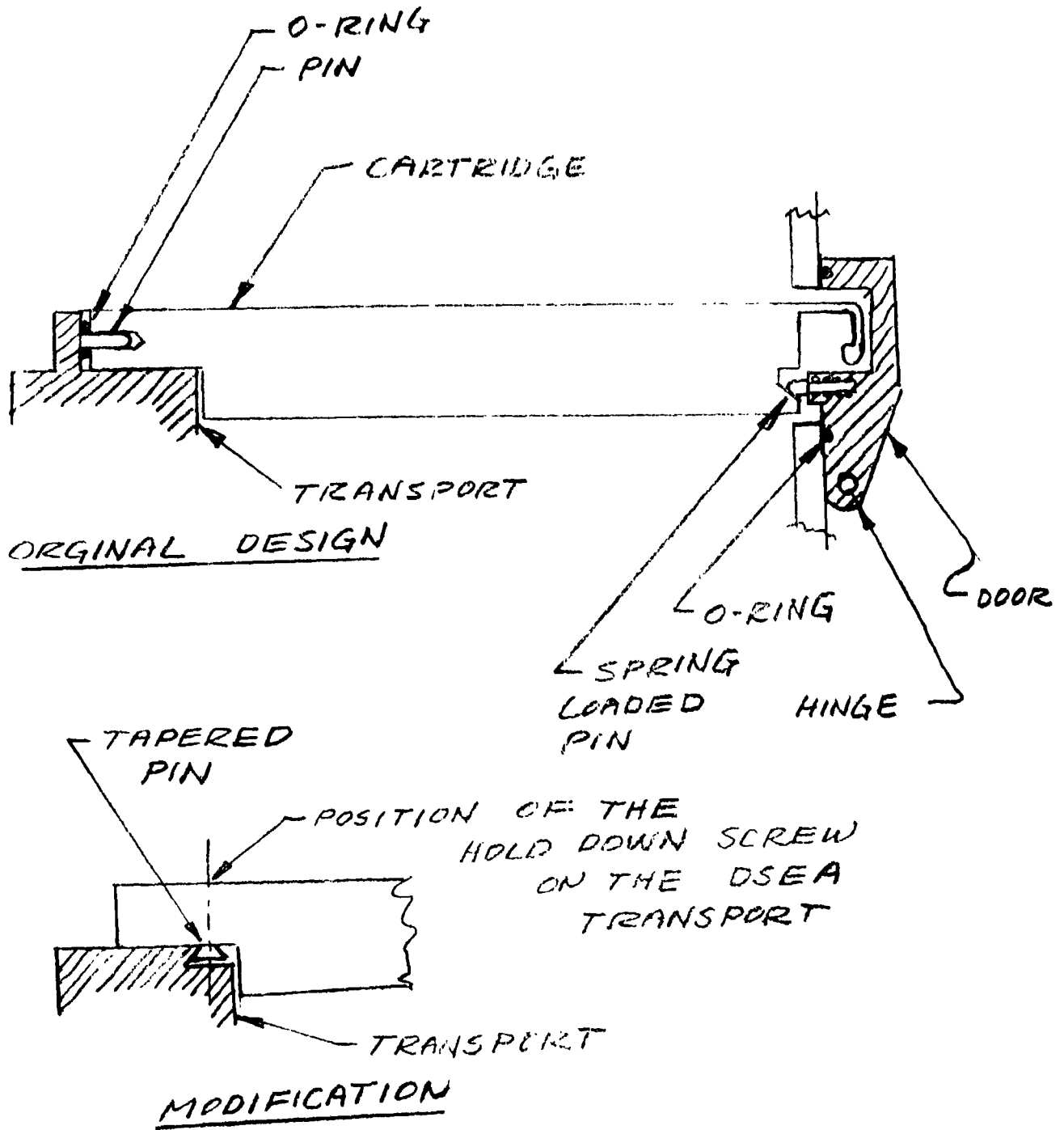

FIGURE 2-2