

**NASA CONTRACTOR
REPORT**

NASA CR-120479

**RESEARCH STUDY ON MATERIALS PROCESSING IN SPACE
EXPERIMENT NUMBER M512**

Final Report on M551, M552, and M553

By J. Martin Tobin and Ram Kossowsky
Westinghouse Electric Corporation
P.O. Box 10864
Pittsburgh, Pennsylvania 15236

December 1973



Prepared for

NASA-GEORGE C. MARSHALL SPACE FLIGHT CENTER
Marshall Space Flight Center, Alabama 35812

(NASA-CR-120479) RESEARCH STUDY ON
MATERIALS PROCESSING IN SPACE EXPERIMENT
NUMBER M512 Final Report on M551, M552,
and M553 (Westinghouse Electric Corp.)
30 p HC \$3.25

N74-35249

Unclas
51082

CSCI 13H G3/30

TECHNICAL REPORT STANDARD TITLE PAGE

1. REPORT NO. NASA CR-120479		2. GOVERNMENT ACCESSION NO.		3. RECIPIENT'S CATALOG NO.	
4. TITLE Research Study on Materials Processing in Space Experiment Number M512 Final Report on M551, M552 and M553				5. REPORT DATE December 1973	
				6. PERFORMING ORGANIZATION CODE	
7. AUTHOR(S) J. Martin Tobin and Ram Kossowsky				8. PERFORMING ORGANIZATION REPORT #	
9. PERFORMING ORGANIZATION NAME AND ADDRESS Westinghouse Electric Corp. P.O. Box 10864 Pittsburgh, Penn. 15236				10. WORK UNIT NO.	
				11. CONTRACT OR GRANT NO.	
12. SPONSORING AGENCY NAME AND ADDRESS National Aeronautics and Space Administration Washington, D.C. 20546				13. TYPE OF REPORT & PERIOD COVERED Contractor Report	
				14. SPONSORING AGENCY CODE	
15. SUPPLEMENTARY NOTES					
16. ABSTRACT <p>Experiment M551 (Metals Melting). Adhesion of the melted metals to the adjacent solid metals, and cohesion of the liquid metal to itself appeared to be equally as strong in zero gravity as on earth. Similar cut edge bead periodicity in cut thin plate, and similar periodic "chevron" patterns in full penetration welds were seen. Weight losses are generally insignificant and indicate no weld metal spattering to form droplets.</p> <p>Experiment M552 (Exothermic Brazing). The most significant practical result is that the design of braze joints for near zero gravity can be very tolerant of dimensional gaps in the joint. This conclusion is based on a comparison of narrow, wide and variable gap widths. Brazing is very practical as a joining or repairing technique for metal structures at zero gravity. The rapid heating rate obtained with exothermic heating was shown to produce excellent wetting and spreading of the Ag-Cu-Li braze alloy (Lithobraze BT 720).</p> <p>Experiment M553 (Sphere Forming). The operation of the hardware developed to locate successive small (0.6 cm) diameter cylinders in the focus of the battery powered EB unit, melt the various metal specimens and deploy some liquid metal drops to drift in space, was generally successful. However, the sphericity and surface roughness were far from those of ball bearings.</p>					
17. KEY WORDS			18. DISTRIBUTION STATEMENT Unclassified - Unlimited <i>W. V. Anderson</i>		
19. SECURITY CLASSIF. (of this report) Unclassified		20. SECURITY CLASSIF. (of this page) Unclassified		21. NO. OF PAGES 29	22. PRICE NTIS

FOREWORD

This final report summarizes the results of experimental and analytical studies in Phases A, B and C of Contract NAS 8-28730 for the 18-month period ending November 15, 1973. This effort was performed by the Materials groups at Westinghouse's Astronuclear Laboratory and Research Laboratories. A Special Summary Report will be written December 15, 1973, at the conclusion of this contract.

The NASA Contracting Officer's Representative (COR) for this study is Mr. James R. Williams, S&E-PT-M. The NASA Principal Investigators for the three experiments involved in this report are Mr. R. M. Poorman (M551), S&E-ASTN-MM; Mr. J. R. Williams (M552), S&E-PT-M; and, Mr. E. A. Hasemeyer (M553), S&E-PT-MWM. All three men are of the Science and Engineering group at Marshall Space Flight Center.

TABLE OF CONTENTS

<u>Section</u>		<u>Page</u>
1	INTRODUCTION	1
2	SURFACE ENERGY AND ITS MEASUREMENT	3
3	SPREADING TEMPERATURE MEASUREMENT METHOD	10
4	EXPERIMENT M551 (METALS MELTING)	10
5	EXPERIMENT M552 (EXOTHERMIC BRAZING)	14
6	EXPERIMENT M553 (SPHERE FORMING)	18
7	EVALUATION AND RECOMMENDATIONS	21
8	PHASE C SUMMARY	23
9	REFERENCES	25

LIST OF ILLUSTRATIONS

<u>Figure No.</u>	<u>Title</u>	<u>Page</u>
1	Representation of tangent to sessile drop silhouette at contact with solid surface as a contact angle, θ .	5
2	Apparatus for measuring contact angle θ .	6
3	Surface energy versus temperature, SS 312 alloy. Al_2O_3 substrate, hydrogen atmosphere.	12
4	Surface energy versus temperature Ag-Cu solder alloys. Al_2O_3 substrate, argon atmosphere.	17
5	Surface energy versus temperature, Ni and Ni alloys. Al_2O_3 substrate, argon atmosphere.	20

1. INTRODUCTION

Under Contract NAS 8-28730, Westinghouse is measuring experimentally and is analyzing some adhesion-cohesion properties of the liquid metals used in Skylab MS/MS Experiments M551 (Metals Melting), M552 (Exothermic Brazing), and M553 (Sphere Forming). This effort is part of a team effort of similarly contracted technical investigators being coordinated by the COR's and the Principal Investigators at MSFC for these three experiments. The other contractors report separately.

Contract NAS 8-28739 has a starting date of May 15, 1972, and a completion date of December 15, 1973. The program is executed in four parts, three work phases and a special summary report:

- Phase A. Preparation of a ground base study plan (1st to 3rd month).
- Phase B. Laboratory test program (3rd to 18th month).
- Phase C. Experiment analysis program (14th to 19th month).
- Special Summary Report. Analyze all adhesion-cohesion phenomena (19th month).

Reporting of progress includes Monthly reports, Phase A Summary Report, Phase B Summary Report, Final Report (all three Phases), plus a Special Summary Report for all adhesion-cohesion phenomena observed by all investigators (to be written in the last month).

Phase A. The objective for Phase A is to define a laboratory test program for Phase B, which is coordinated with, and complements the efforts of the other investigators. As a result of Phase A, the contracted investigators are given different roles. Several are assigned to characterize and evaluate both ground (Phase B) and Skylab flight (Phase C) specimens. Others are to perform thermal analysis and convection analysis.

Although the analytical equations and models are available to analyze mechanically the convection, wetting, liquid flow, and adhesion phenomena; it was found that basic surface properties data are generally not available. This contract effort is assigned to obtain these data both experimentally and analytically in support of the convection analysis effort for M551, 552, and 553. The required data for specific liquid metals are contact angles, spreading temperatures, work of adhesion, surface energy, and both the composition and temperature variation of surface energies. These requirements were defined for Phase B of this contract.

Two other MS/MS Experiments, M554 (Directional Solidification) and M555 (Single Crystal Growth) have been also considered in Phase A. However, since the liquids in these experiments do not have free surfaces, Marangoni type convection is not expected and thus produces no requirement for surface property measurements.

Phase B. Contract NAS 8-28730 was changed to limit the scope to Experiments 551, 552 and 553. The laboratory test program defined in Phase A was conducted in Phase B. The results were transmitted to all investigators for use in their analyses.

Phase C. Data from ground base tests, KC-135 jet parabolic flight tests and the Skylab flight have been provided to this investigator by MSFC for the purpose of experiment analysis. By comparison of ground and flight specimen evaluation it is expected to determine the effect of zero gravity on adhesion-cohesion phenomena. Some aspects of this analysis developed in this contract are reported here. However, the final specimen evaluation data and the final reports from the other investigators are due at the same time as this report. A Special Summary Report will be written after a final report meeting of all investigators at MSFC on December 4, 5 and 6, 1973 and will be a comprehensive review of the subject for all investigators results.

2. SURFACE ENERGY AND ITS MEASUREMENT

The importance of adhesion-cohesion phenomena to the utilization of orbit zero gravity (mass acceleration) conditions is recognized by the Process and Engineering Laboratory at MSFC and the contracted scientific advisors for the Materials Science/Manufacturing in Space (MS/MS) program on the Skylab mission. Greater understanding and more meaningful analysis of the mechanics of fluid motion in these experiments require measurement of liquid metal surface energies and both the temperature and the concentration coefficients of variation of surface energies for the liquid metals used.

Surface Energy, Adhesion and Cohesion. Surface energy is a basic manifestation of the thermodynamic property of cohesive energy in the condensed states. Gases condense to liquids or solids when the cohesive bonding forces between their atoms or molecules exceeds the opposing tendency to vaporize. At sufficiently low temperatures even inert gas atoms like helium will condense to a coherent liquid as a result of the weak attraction of van der Waal's forces.

Interior atoms (or molecules) removed by more than 100 atoms distance from a free surface have a symmetrical attraction to the neighboring atoms when averaged over time. Surface atoms do not have symmetrical attraction, and the unsatisfied bonding normal to the surface results in a net attraction of surface atoms to the interior. This results in a surface tension, which is a net mechanical tension in the surface layer tangential to the surface curvature. To obtain the surface energy in the case of liquids, the mechanical effects of the surface tension are measured. The cohesion of a liquid increases directly with its surface energy. A degree of bonding of surface atoms to the adjacent phase across the interfacial surface will decrease the surface energy of both phases and increase adhesion between the two phases. In the case of liquid/liquid and liquid/solid interfaces the work (energy) of adhesion can be appreciable.

Values of surface energies are available for only a few of the elements of the periodic table. Measurements for metallic alloys and the temperature coefficients of variation for the elements and their alloys are scarce and unreliable. Most reliable measurements of surface energies are made with covalent bonded molecular liquids near room temperature. One elemental liquid metal, mercury, has been well characterized near room temperature. However, experimental difficulties plague the measurements of surface energies of other liquid metals at elevated temperatures.

Sessile Drop Method. The preferred technique for measuring surface energies of liquid metals at elevated temperatures is the sessile drop method. A non-wetting small drop of liquid metal resting on a plate, such as alumina, in a suitable atmosphere will adopt a shape from which the surface energy may be obtained through analysis.^(1,2) The angle which the tangent to the silhouette of the drop makes with the solid surface is a measure of wetting and adhesion. The values of the contact angle were extensively measured at normal temper-

atures by Dr. W. A. Zisman and co-workers.⁽³⁾ The contact angle is designated θ in Figure 1. The degree of wetting increases with decreasing θ , from 180° to zero. At θ equal to zero, complete wetting occurs; the liquid spreads over the solid surface, extending its area of contact and reducing its thickness. Spreading is essential to brazing as in Experiment M552 Exothermic Brazing. Non-wetting and a low, reproducible work of adhesion are required for deployment of liquid metal drops to drift free from the alumina pedestals in Experiment M553 Sphere Forming. Convection of locally heated melted metals is found to be largely determined by the temperature coefficient of variation of surface energy in Experiment M551 Metals Melting in zero gravity.

Sessile Drop Apparatus. The apparatus shown schematically in Figure 2 is similar to that used at Massachusetts Institute of Technology (MIT) by Kingery and Humenik.⁽⁴⁾ It consists of a 1.22 meters (4 feet) length of quartz tube with provisions for evacuation, vacuum gauging and backfilling with a desired atmosphere. Heating is provided by an R. F. generator (450 KHz) connected to an induction coil. The weighed metal sample is heated both by radiation from the boron nitride susceptor liner, and by direct R. F. coupling to the metal sample. Heating rate can be varied from an essentially equilibrium condition to a maximum rate of $6.7^\circ\text{K}/\text{sec.}$ ($400^\circ\text{C}/\text{min.}$). The temperature is monitored continuously by means of a thermocouple attached to the solid substrate near the liquid metal sessile drop.

Before a test, both the metal and alumina substrate are cleaned as shown in Table I. The bead of metal is placed on the substrate, which is then inserted into the boron nitride liner, and the entire assembly of graphite felt and liner is pushed into the center of the tube. Using a sensitive water level, the cross grid on the telescope is adjusted to level the telescope. Then the substrate is manipulated till it is level.

TABLE I. CLEANING PROCEDURE

A. METALS

1. Vapor degreaser - drying
2. Ultrasonic detergent cleaning - rinsing - drying
3. Solvent rinsing - drying

B. Al_2O_3 SUBSTRATE

1. Ultrasonic detergent cleaning - rinsing - drying

Sessile Drop Concept

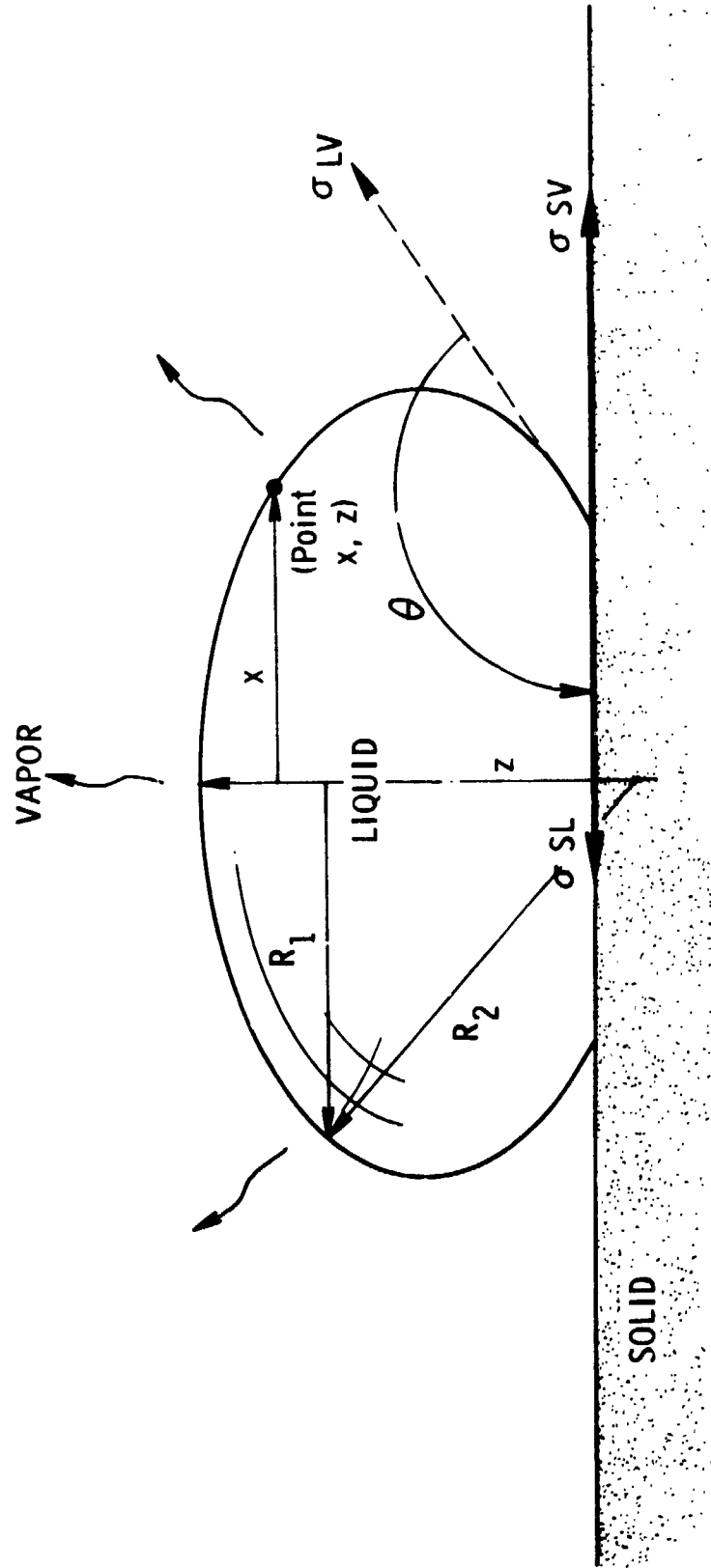

Figure 1. Representation of tangent to sessile drop silhouette at contact with solid surface as a contact angle, θ .

Dwg. 724B769

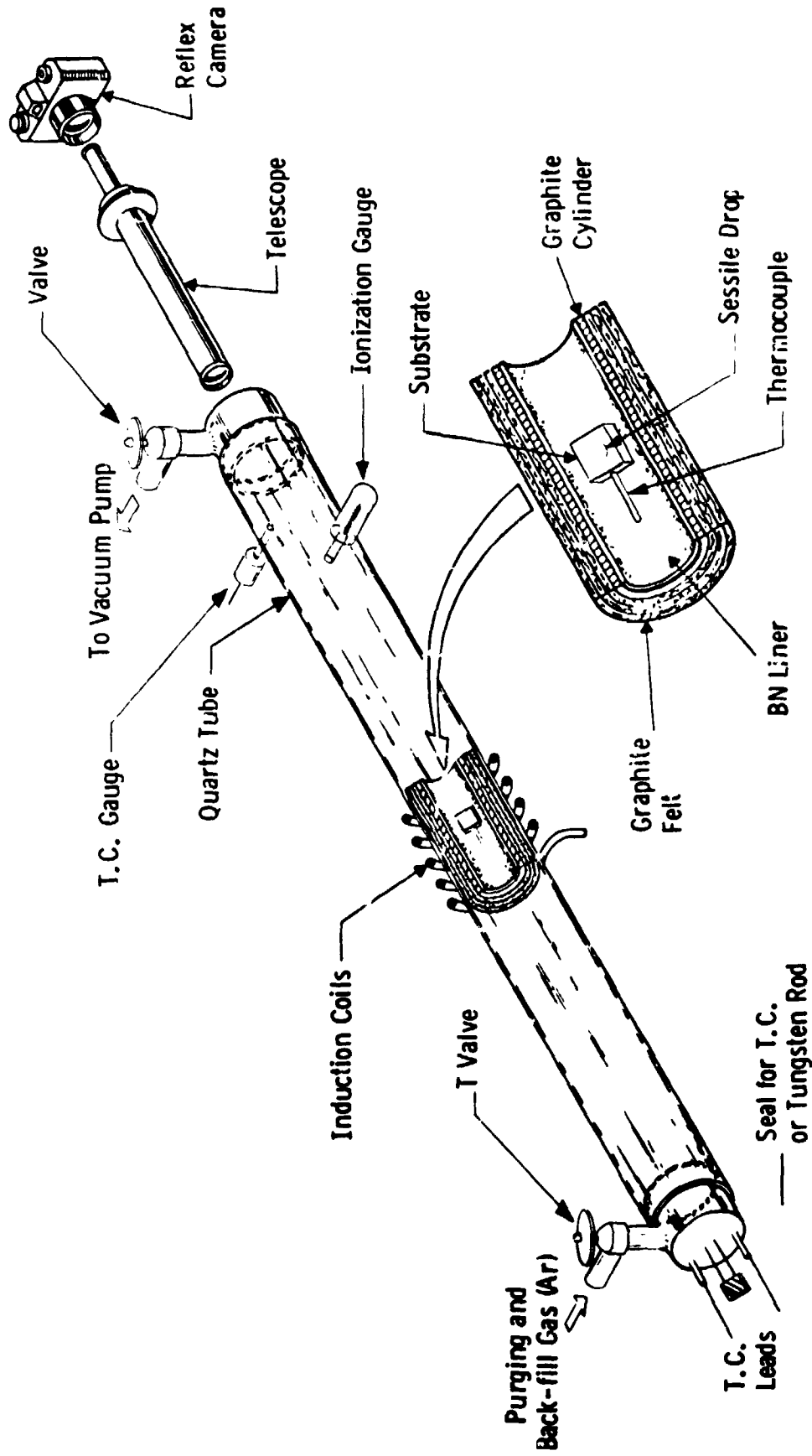

Figure 2. Apparatus for Measuring Contact Angle θ .

The tube is then closed and evacuated overnight to $1.33 \times 10^{-3} \text{ N/m}^2$ (10^{-5} Torr).

Upon startup of heating, the pressure rises and the system is degassed for about 2 hours at 473°K (200°C). Following that a vacuum test is run. Then high purity, precleaned argon gas is fed into the tube.

The temperature is raised at the desired rate and after the metal melts the shape of the sessile drop is recorded on the 35 mm photographic film at any desired temperature or time interval. The use of the 35 mm reflex camera is preferred to the use of manual optical goniometer readings since the photograph is more rapid. The size and composition of the alloy sessile drop at elevated temperatures can change much during the long isothermal hold periods required for goniometer readings of the sessile drop shape. The exact magnification factors for the photographs are obtained by simple calibration.

Analysis of Sessile Drop Shapes. Firstly, the measurement of contact angles at the contact of the liquid drop to the solid surface is made by enlarging the photographic image of the silhouette to 24-28X magnification and tracing the outline on paper. The tangents on both the left and right side are drawn and the contact angle θ , as shown in Figure 1, is measured. The two values of θ from one drop are generally not identical, and the average of the two contact angles is reported. The lack of sessile drop symmetry is an experimental difficulty not overcome in this study. There is appreciable scatter in the variation of the average contact angle θ with temperature.

Secondly, the equilibrium liquid/vapor interfacial surface energy, σ_{LV} , is calculated from the shape of the drop.

Analysis of the liquid/vapor interfacial surface energy was quite successful. Only the shape of the top half of the sessile drop was used as it is relatively isolated from the asymmetrical mechanical forces at the liquid to solid contact. Only data taken with argon or hydrogen gas atmosphere is used as the use of gas approximated the saturated vapor requirement according to Langmuir vaporization theory. Only measurements on pure alumina (Al_2O_3) substrate were used as the liquid metals do not wet alumina and the sessile drops have the necessary significant curvature as shown in Figure 1.

Two images of the drop shape at high magnification were used to find the true axis of symmetry. The one image was reversed in projection and a best fit for congruency over the other image was obtained. Trial and error was used to find the axis by means of a test of congruency upon reversal. The true position of the apex of the drop is the intersection of the true axis with the drop outline. An inherent lack of symmetry in shape was thus graphically averaged.

Surface energies are calculated from the shape of the sessile drop following the original analysis of Bashforth and Adams⁽¹⁾. A computer program was developed by Butler and Bloom⁽²⁾ fitting the experimentally observed drop shape to the theoretical curve by means of iteration. Input data required are: 1) pairs of x, z coordinates (see Figure 1) describing the shape of the right and left sides of the top of the drop, 2) the gravity acceleration constant, g, and 3) the density of the liquid, ρ , at the temperature of measurement. For the theoretical curve, the following relation is used:

$$\frac{1}{R_1} + \frac{1}{R_2} = \frac{P}{\sigma_{LV}} \quad (1)$$

where σ_{LV} is the liquid/vapor surface energy; R_1 and R_2 are the radii of curvature at any point on the surface; and P is the hydrostatic pressure given by:

$$P = gz\rho + C \quad (2)$$

where z is the distance below the apex of the drop along the axis (see Figure 1), ρ is the liquid density (buoyancy is neglected), and g is the gravitational constant.

The original Fortran 4 computer program by Butler and Bloom was adapted to our UNIVAC 1108 and was dubbed SURFTEN.

The SURFTEN code fits the experimental shape coordinates by multiple iteration to a best fit with the theoretical shape of a drop. Tabulated data for sessile drop analysis were given very early (1883) by Bashforth and Adams⁽¹⁾. By simple modification, the code can print a Bashforth and Adams table in any desired degree of detail, which is useful since the original table is difficult to find.

Values for the liquid density, ρ , as a function of temperature for the seven liquid metal alloys tested were estimated from the liquid metal element density values using a perfect solution approximation. The elemental values are listed by S. Z. Beer⁽⁵⁾. A sensitivity analysis indicates that minor variations of 0.1 g/cm³ in liquid density are not as significant as errors in drop dimensions.

It should be noted that the analysis of the σ_{LV} by this means does not require a knowledge of the contact angle θ .

Thirdly, the work of adhesion of a liquid metal drop to the solid Al₂O₃ surface is calculated. It is derived from the general relation:

$$W_A = \sigma_{LV} + \sigma_{SV} - \sigma_{SL} \quad (3)$$

where σ_{LV} , σ_{SV} and σ_{SL} are the respective surface energies for the liquid/vapor, solid/liquid phase interfaces.

The work of adhesion cannot be measured directly. It is derived analytically from the approximate relation:

$$W_A^* = \sigma_{LV} (1 + \cos \theta) \quad (4)$$

where the liquid/vapor surface energy, σ_{LV} , and the contact angle (see Figure 1), θ , are separately determined values at the same temperature.

Experimental Difficulties. Many measurements of sessile drop shapes in dynamic vacuum were attempted early in this program. The dynamic vacuum was used to simulate the expected vacuum in the Skylab M512 working chamber.

It was found that all alloy compositions varied during the test period because of rapid selective vaporization and change of the alloy composition. The difficulty with composition change and also drop size shrinkage in a dynamic vacuum was relieved with the use of an atmosphere of purified argon gas (or hydrogen).

All measurements of contact angle reversibility (with rising or falling temperature) and symmetry (right and left sides of the sessile drop silhouette) were unsuccessful. With the conditions used in these ordinary sessile drop experiments, there is good evidence that there is no mechanical reversibility at the three phase boundary between the drop, solid surface and vapor space. Particularly suspect are: surface contaminants and liquid/solid interaction.

Other experimental difficulties were found in attempting to measure the spreading temperature of the braze alloy by means of equilibrium sessile drop technique, using the two Experiment M552 metals SS 304L and pure Ni as substrates, in vacuum. The whole approach was abandoned because of difficulties. In principal, the temperature at which the equilibrium contact angle goes to zero ($\theta = 0$) and spreading occurs can be obtained by extrapolation of values of θ at a number of lower temperatures. Slow heating was used to get equilibrium θ values. The principal difficulty was that with slow heating the braze alloy would not spread at temperatures well above the temperature where complete spreading occurs upon rapidly heating. At the fastest heating rate possible in the sessile drop apparatus, $6.7^\circ\text{K}/\text{sec}$. ($400^\circ\text{C}/\text{min}$), complete spreading on SS 304L is obtained at 1450°K . At lower heating rates spreading could not be obtained. Therefore, a new apparatus and technique were used to simulate the $20^\circ\text{K}/\text{sec}$. ($1800^\circ\text{F}/50 \text{ sec.}$) heating rate and other conditions measured in Experiment M552 ground testing. This practical spreading temperature measurement method is described next.

3. SPREADING TEMPERATURE MEASUREMENT METHOD

Spreading Temperature Measurement. The spreading temperature is defined as the temperature at which the contact angle of a liquid sessile drop on a solid surface goes to zero ($\theta = 0$). Because of the high volatility of lithium from Lithobrazo BT720 alloy, the spreading temperature cannot be reliably measured at slow heating rates in a vacuum, and wetting is not as good as in fast heating rates of Experiment M552 (Exothermic Brazing).

A special technique was used to measure the excellent wetting and values of the spreading temperature of the Lithobrazo 720 braze alloy on the SS 304L and nickel metals used in M552.

The actual spreading of the braze alloy at nominal M552 pressures and heating rates was simulated. The SS 304 and Ni substrates were resistively heated in a BREW vacuum furnace to simulate the M552 conditions. The maximum temperature reached was sequentially increased till the temperature was found when the braze alloy not only melted, but spread. The melting point of Lithobrazo BT 720 was found to be 1013°K. The increase of the spreading temperature over the melting temperature was recorded.

4. EXPERIMENT M551 (METALS MELTING)

A battery operated 2 kilowatt electron beam (EB) welder unit was mounted in the center of the M512 panel on Skylab. It was focussed to the center of a 40 cm (16 inch) diameter spherical working chamber, evacuated to space through a 10 cm gate valve. Bead-on-plate welding tests were performed using three metal discs; tantalum, SS 304, and Al 2219. The discs were slowly rotated in front of the beam. The discs were previously milled to have various constant and gradient thicknesses to get EB cutting action, as well as full and part penetration welds. Dwell periods (no movement) were provided also.

Measurements. Of the three metals tested, the tantalum melting point was far above the melting point of the sessile drop apparatus materials. And, the alumina alloy oxidized so readily that accurate sessile drop measurements were not possible even in hydrogen. But in a reducing atmosphere of pure hydrogen, the surface energy and contact angle measurements for SS 304 on pure alumina (AlSiMag753) were measured; using the sessile drop method and the apparatus described above. The use of a purified hydrogen atmosphere is necessary. It is used in order to avoid the extraneous surface tension effects of chromium oxide. The atmospheric pressure of hydrogen also minimized the composition change problem observed with vaporization into a vacuum (Experimental Difficulties). The initial carbon content was 0.06 percent by weight.

The resulting values for the estimated liquid/vapor surface energy are given in Table 2.

TABLE 2. ESTIMATED SURFACE ENERGY OF SS 304
(IN HYDROGEN ATMOSPHERE)

Temperature (°K)	Surface Energy (10^{-5} N/m)	Liquid Density (gm/cc)
1868	1800	6.97
1943	1779	6.89
1993	1756	6.81
2058	1710	6.73

These values are adequate for engineering evaluation analysis. The absolute accuracy cannot be estimated, and no previous measurements have been found for comparison. Values of surface energy as a function of measurement temperature are graphed in Figure 3. The important temperature coefficient of variation of the surface energy for SS 304 alloy is rather large, $-0.47 (x 10^{-5} \text{ N/m}^{\circ}\text{K})$ ($\text{ergs/cm}^2\text{C}$).

Analysis and Discussion. The efforts to analyze the flight specimens for evidence of adhesion/cohesion phenomena continue as data arrive. Thus far, no unique effect of zero gravity has been found. The movie pictures of the welding show familiar phenomena.

It appears from the data submitted that EB welding in-space can be done about as well as on earth. Two seminars were held with Westinghouse metals joining and welding experts. This conclusion is a consensus of opinion based primarily upon the movies projected with a 16 mm time motion study projector. Strong effects of the EB weld beam on the convection and flow of the molten weld metal are seen in both the Skylab flight movies and the flight specimens. It was suggested by Dr. B. W. Schumacher⁽⁶⁾ of our Westinghouse Research Laboratories that the most powerful force causing movement of the liquid is that due to vaporization resulting from the high energy fluxes and temperatures where the electron beam impinges on the liquid metal. The magnitude of the resulting recoil pressure, p , can be estimated according to G. A. Askaryan and E. M. Moroz⁽⁷⁾, who give the analytical equations relating the recoil pressure due to vaporization to the pressure of the beam itself. In high energy fluxes (intense EB) the recoil pressure can be hundred of thousands of atmospheres with beam current densities at the focus of an electron beam cutter of 10^6 amps/cm². At the much lower current densities in Experiment M551, a very significant force is still expected. According to Askaryan:

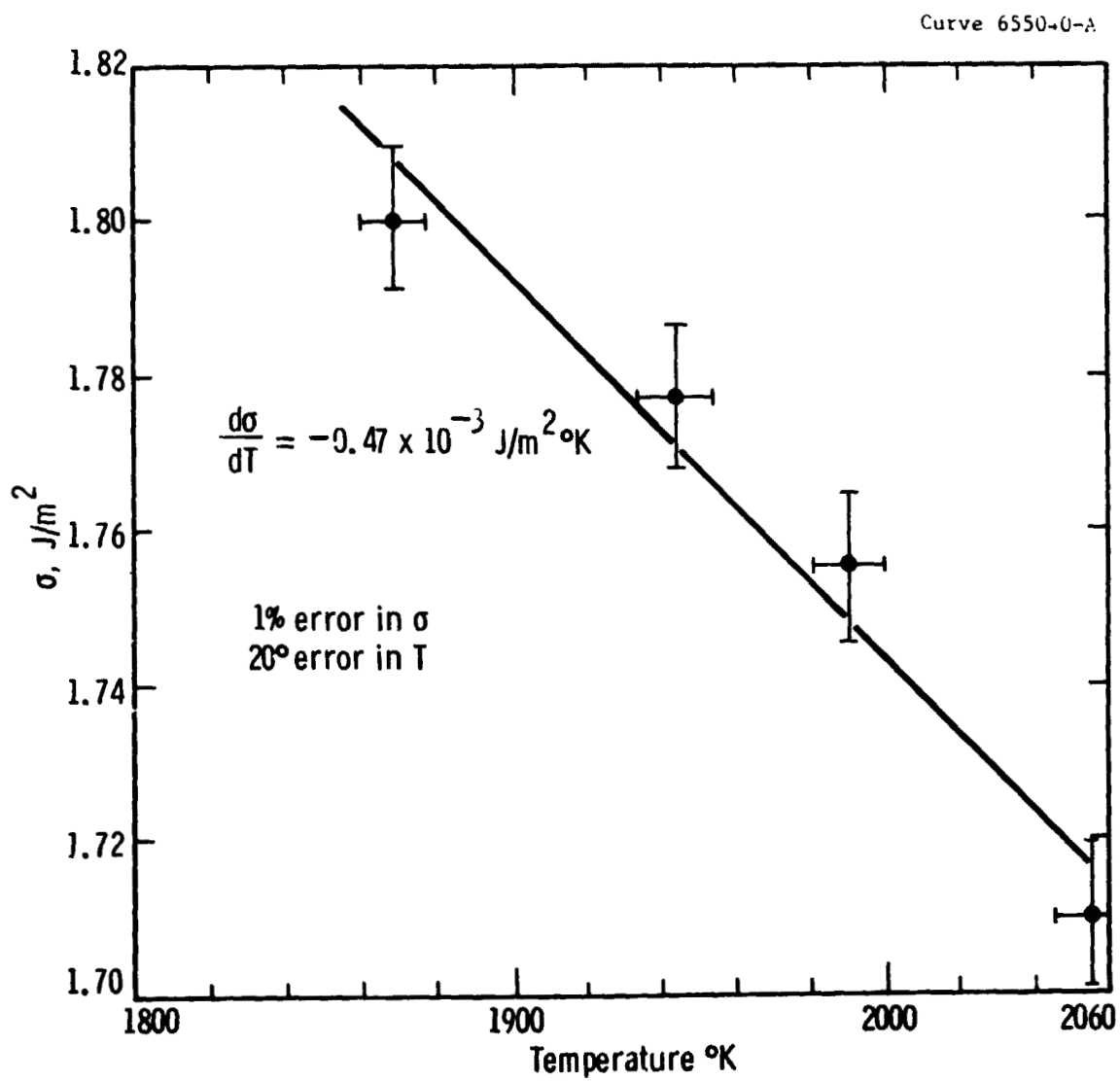

Figure 3. Surface energy versus temperature, SS 304 alloy.
Al₂O₃ substrate, hydrogen atmosphere.

p	=	$\alpha I V_f / \lambda$
p	=	recoil pressure
I	=	energy density flux
V_f	=	final velocity of vapor flow
λ	=	$\lambda_0 + (1/2) V_f^2$
λ	=	specific energy of evaporation and acceleration of the vapor
α	=	fraction of energy used in evaporation
α	=	1, at high beam current densities
p_1	=	EB beam pressure
p/p_1	=	$V_1 V_f / 2 \lambda$

Some qualitative observations of the effects of surface tension in electron beam welding can be made based upon the M551 data and movies.

1. When the EB has melted through a thin metal plate (full penetration), surface interface energy, σ_{LS} , will determine whether the recoil pressure, p , will open a hole through the metal (cutting action). However, neither the analytical model nor the input data to analytically predict the switch from cutting action to full penetration welding with increasing plate thickness are available.
2. Surface energy will affect the periodicity of bead contour at the edges in the cutting mode. However, no significant change in zero gravity is noted.
3. Surface energy probably determines the periodicity of the chevron patterns on the weld bead caused by oscillation of the liquid pool under the EB. However, the chevron patterns were not noticeably affected by the zero gravity.
4. Spattering from the weld crater is caused by surface energy effects on dynamic oscillations in the weld crater. No observations of spattering were made on the M551 flight experiment.
5. In addition to the violent motion of the liquid caused by the recoil force, a convection effect due to the high temperature gradients in the liquid at the high energy fluxes is expected. It is called the Marangoni effect, and operates because of the temperature variation of surface energy. It requires a free surface to operate, and a substantial temperature gradient, such as in Experiment M551.

Much of the detail of liquid motion under the electron beam is obscured by the high light intensity. Most direct information is obtained from the flight specimens, and the weld beads are very similar between one and zero gravity. Some difference in the buoyancy of pores and dispersed scale particles has been observed by surface and metallographic examination.

A detailed treatment of the physical principle underlying the formation of the cavity in electron beam welding was written by O.C. Wells⁽⁸⁾. He shows that the two most significant forces involved in weld cavity formation are the metal vaporization and the surface tension.

Analysis of liquid convection and fluid flow is performed in another contract. SEM and metallographic examinations are reported by other investigators.

The Special Summary Report will be written next and include a comprehensive review of adhesion-cohesion phenomena observed by the team of investigators.

5. EXPERIMENT M552 (EXOTHERMIC BRAZING)

This experiment tests a zero gravity technique to braze tubes of SS 304L and pure Ni with a commercial Lithobrazo BT720 alloy (the Ag/Cu eutectic with a small 0.47% Li additive). It uses a radioactive tracer technique (Ag-110) to find differences in flow of the braze in a sleeve joint assembly with or without gravity. It tests the effect of gaps between parts. The effect of zero gravity on the solidification of the near eutectic braze alloy will also be examined.

The joining technique requires only a small amount of electrical energy for ignition of a chemically exothermic reaction which heats the sleeve assembly to braze temperatures rapidly. The sleeves are 1.87 cm (0.75 inch) diameter. The Experiment M552 package contains four assemblies, each consisting of a tube with a sleeve and a ring of braze alloy in slots at either end of the sleeve, surrounded by the exothermic heating assembly. Each was ignited in sequence. The package was mounted in the M512 facility working chamber of 40 cm (16 inch) diameter.

Measurements. Three type of measurements were made. First, the spreading temperature, where the contact angle goes to zero, was measured with the simulated conditions as measured in ground tests of the M552 package units. Second, the equilibrium sessile drop measuring technique (Spreading Temperature Measurement Method), using argon atmosphere and pure alumina (AlSiMag753) substrate were used to analyze the surface energies at various temperature for the Lithobrazo BT720 braze alloy, and find the temperature coefficient of variation for the surface energy. Thirdly, similar sessile drop experiments were performed with the same braze alloy without the lithium additive, Braze BT720.

The required data are the spreading temperatures of the Lithobraze BT720 alloy used in the Experiment M552 on the two metals used, SS 304L and pure Ni; also, the estimates of the temperature and lithium concentration coefficients of variation for the braze alloy.

Spreading Temperature Results. The object of the new test technique described in Section 4 is to measure the temperature at which the contact angle between liquid and solid goes to zero and the braze spreads on the substrate metal. Resistance heating duplicates the M552 exothermic heating rate curve. Lithium loss was reduced considerably.

Complete spreading (contact angle $\theta = 0$) was observed at a higher temperature for SS 304 than for Ni substrate:

	<u>ΔT Above Melting Point</u>	<u>Braze Spreading Temperature</u>
SS 304	$245 \pm 5^\circ\text{K}$	$1258 \pm 5^\circ\text{K}$
Ni (pure)	$97 \pm 5^\circ\text{K}$	$1110 \pm 5^\circ\text{K}$

The remarkable improvement in wetting over slowly heated contact angle measurements is apparently due to the rapid M552 heating rate and the negligible lithium loss to the vacuum at 6.67 N/m^2 (5×10^{-2} Torr). The higher temperature required for complete and fast spreading on SS 304 compared to Ni is apparently due to the presence of a layer of chromium oxide on clean stainless steel which requires a higher temperature for reduction of the oxide by the lithium additive in the braze alloy.

Surface Energy Results. The measurement of the liquid/vapor surface energy for both Lithobraze BT720 and Braze BT720 was performed using the apparatus and method for sessile drop shape measurement, plus the computer analysis program, both described in the previous Section 2. Lithium content is essentially unchanged with the use of the atmospheric pressure of argon. Lithium analysis before and after the sessile drop test (circa 3 hours) showed half of the lithium remaining, a great improvement over the vacuum test results:

	<u>Lithium Content</u>	<u>M. Pt. Obs.</u>
Lithobraze BT720 (before)	0.47*	1013°K
Lithobraze BT720 (after)	0.25*	1033°K

*atomic absorption technique

The values of surface tension, σ , for both the Ag/Cu eutectic braze alloy BT720, and the same alloy with nominally 0.2 percent lithium addition, Lithobraze BT720, were given by the computer as:

	<u>Temperature</u>	<u>Surface Tension</u>
Braze BT 720	1173°K	996 x 10 ⁻⁵ N/cm*
	1273	965
	1373	956
	1473	917
Lithobraze BT 720	1273	967
	1413	942
	1473	930

*Multiply by 10⁵ to get dynes/cm or ergs/cm²

The surface energies of the two Ag/Cu braze alloys are plotted as a function of temperature in Figure 4. With an error of 1% in σ and 20°K in T, a least mean square line gives a slope of $S \cong d\sigma/dT = -0.25 \times 10^{-5} \text{ N/cm}^{\circ}\text{K}$ ($-0.25 \text{ ergs/cm}^2\text{ }^{\circ}\text{C}$). This can be compared with a value of $S = -0.31 \times 10^{-5} \text{ N/cm}^{\circ}\text{K}$ for pure copper. (9)

Analysis and Discussion. It should be noted that the errors given are relative errors, since no means is currently available to find the absolute errors with the experimental conditions used at high temperatures.

It is further to be noted that the data for the eutectic Ag/Cu alloy designated BT720 are not significantly different from the data for the same alloy with the nominal 0.2% lithium addition, designated Lithobraze BT720. This observation is in accord with the proposition (10) that the lithium addition does not lower the surface energy but rather acts to reduce surface oxides on the metal substrate. Lithium is an exceptionally strong reducing agent and has a high free energy of oxidation. It can reduce the oxides of most structural alloy constituents. Reduction of the thin oxide film on a nominally clean metal surface will lower the liquid braze/metal substrate interfacial energy, decrease the contact angle and promote spreading. It is likely that the lithium oxide vaporizes from the braze metal surface.

Thus the coefficient of variation of the surface energy with lithium content is simply zero since no difference was observed between the two alloys.

This investigator proposed the use of the radioactive tracer technique to identify flow patterns in the M552 braze alloy after completion of the exothermic brazing. The Oak Ridge National Laboratory's Division of Isotopes developed the techniques and successfully plotted the two-dimensional flow patterns using Ag-110 isotope for both ground base and flight specimens. Differences were noted and related to zero gravity. Their results are reported separately, but will be evaluated in the Special Summary Report to be written in this contract and reporting all adhesion/cohesion phenomena.

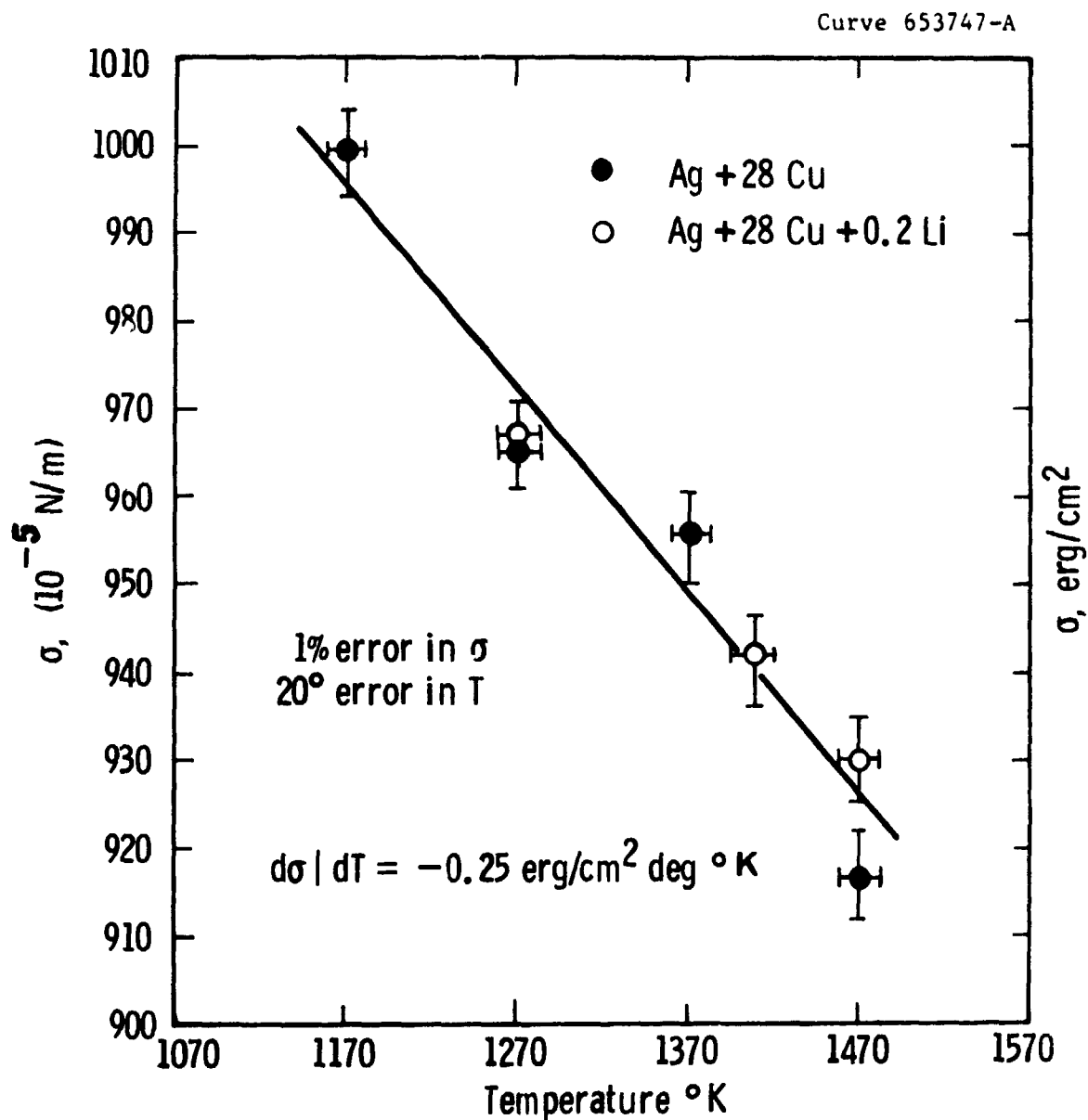

Fig. 4 -Surface energy vs temperature Ag-Cu solder alloys. Al_2O_3 substrate, argon atmosphere.

6. EXPERIMENT M553 (SPHERE FORMING)

The battery powered, 2 kilowatt electron beam welding unit on panel M512 was used to melt 0.6 cm (0.25 inch) diameter cylinders of nickel and three of its alloys (Ni-1Ag, Ni-12Sn, and Ni-30Cu). Duplicate sets of fourteen metal cylinders were mounted on separate wheels. Their axes were radially oriented at the periphery of the electrically driven wheels. Each specimen was mounted on pure alumina (AlSiMag 735) pedestal, and electrically grounded through the pedestal with a spring loaded wire called a "sting". The wheels were rotated, then stopped to place each specimen in the electron beam sequentially.

The object of the experiment was to melt the metal cylindrical specimens, releasing the "sting" and deploying (in most cases) the liquid metal drop to drift in the M512 working chamber. The drifting drop forms a liquid sphere, which then solidifies. Evaluation of the solidification through the resulting surface and structural characteristics are the subject of separate reports.

The forces tending to deploy the liquid spheres from the pedestal are vaporization and the mechanical reaction to the sting retraction. The resisting forces are due to the drop momentum and the wetting of the liquid drop to the alumina pedestal. The energy required to separate the wetted drop from the alumina pedestal is called the work of adhesion, W_A . It was experimentally determined for the four metals used in this experiment.

Measurements. The sessile drop technique was used to measure the surface energy, σ_{LV} , through drop shape analysis and also the average contact angle, θ . These two values were then used to calculate the work of adhesion, W_A . The sessile drop experimental technique and the analytical methods to find σ_{LV} are described in Section 3.

The data below were obtained by SURFTEN analysis from the shapes of sessile drops at three different temperatures for the four liquid metals on pure alumina substrates:

<u>Alloy</u>	<u>Temperature</u>	<u>Liquid/Vapor Surface Energy</u>
Pure Nickel	1773 ^o K	1719 x 10 ⁻⁵ N/cm
	1973	1676
	2068	1659
Nickel - 1% Silver	1793	1637
	1983	1586
	2138	1564
Nickel - 12% Tin	1683	855
	1983	806
	2093	782
Nickel - 30% Copper	1743	1506
	2003	1468
	2073	1411

The surface energy as a function of temperature for the four Ni alloys is plotted in Figure 5. It is clear from the data (disregarding the one point on the Ni-30Cu line) that:

a) A straight line fit is obtained for all data, even though only three points are calculated per alloy.

b) The temperature coefficient for all alloys is identical and is $S = -0.2 \times 10^{-5}$ N/m °C (-0.2 ergs/cm² °C).

The average contact angle measurements were obtained from the same sessile drops so that the work of adhesion can be calculated using the following approximation:

$$W_A^* = \sigma_{LV} (\cos \theta + 1) \quad (4)$$

The values of σ_{LV} , θ , and W_A are given in Table 3.

TABLE 3. WORK OF ADHESION (W_A) FOR NICKEL AND ITS ALLOYS ON Al_2O_3 ($\times 10^{-5}$ N/cm)

	Temp. (°K)	σ_{LV}	θ (deg.)	W_A
Nickel	1773	1719	135	503
	1973	1676	137	450
	2068	1659	(113)	(1011)
Ni-1% Silver	1793	1637	135	479
	1983	1586	136	445
	2138	1564	128	601
Ni-12% Tin	1683	855	130	305
	1983	806	133	256
	2093	782	130	279
Ni-30% Copper	1743	1506	126	621
	2003	1468	130	524
	2073	1411	133	449

It should be noted that the nickel-tin alloy shows a significantly lower work of adhesion and is easier to deploy as a liquid sphere from the alumina substrate. These lower values of W_A result primarily from the lower surface energy for the nickel-tin alloy.

Analysis and Discussion: The above results appear to be rational and do not conflict with previously reported results, in those cases where they were previously measured.

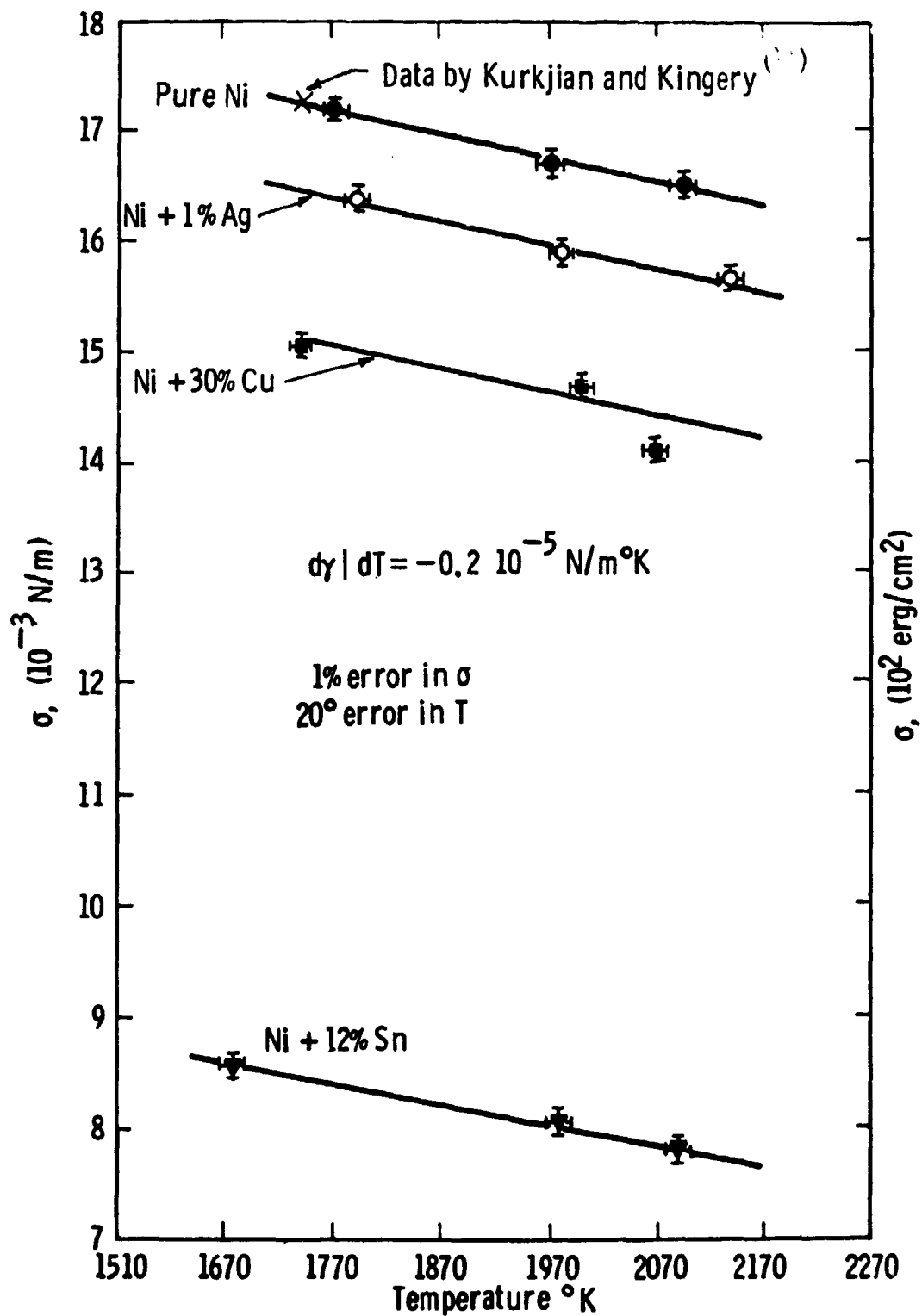

Fig. 5 -Surface energy vs temperature, Ni and Ni alloys, Al_2O_3 substrate, argon atmosphere.

The data for pure Ni compares well, at low temperature with previously reported results by Kurkjian and Kingery⁽¹¹⁾. They obtained $1725 \times 10^{-5} \text{ N/cm}$ (1725 erg/cm^2) for Ni at 1748°K (1475°C) while the present data indicates $\sigma = 1720 \times 10^{-5} \text{ N/cm}$ (1720 erg/cm^2) at the same temperature. However, we note a substantial disagreement for the temperature coefficient of σ , whereas they report $S = d\sigma/dT = -0.9$, the present data indicates much less dependence of σ on temperature.

It should be noted that the data reported by Kurkjian and Kingery was obtained in vacuum. The present data was obtained in $1.3 \times 10^5 \text{ N/m}^2$ (1 atm) of argon. The fact that all alloys exhibit the same slope, $d\sigma/dT$ indicates that the temperature dependence of σ is derived from absorbed atmosphere - probably argon atoms. The variance in $d\sigma/dT$ between vacuum and argon can thus be reconciled.

The contact angle values for pure Ni on Al_2O_3 compare well with those reported for Ni with very small additions of In, Sn, Cr and Ti by J. W. Taylor⁽¹²⁾. He also shows a marked decrease in the surface energy of Ni with the addition of up to 1.86 percent Sn. This also agrees with the much lower surface energy found here for 12 percent Sn.

The very low surface energy for the Ni-12Sn alloy suggest easier deployment of these liquid spheres from their alumina pedestals in Experiment M552.

Examination of photographs and microphotographs of the surface and internal structure of both the ground base and flight specimens are reported separately. No clear difference is apparent which can be attributed to zero gravity effects on adhesion-cohesion phenomena. However, it is obvious from photographs by SEM that most of the solidified spheres have rough surfaces. This roughness seems to result from growth of dendrites while the sphere was partly liquid and had a larger volume. Then, when the remainder of the liquid solidified, coherence and wetting to the dendrites caused the liquid to retract to the interior of the sphere leaving projecting dendrites at the surface. When a complete casing of solidified metals formed over spheres with some liquid still inside, the shrinkage of the last liquid to solidify caused shrinkage voids in the spheres. Thus the most general adhesion/cohesion phenomena observed result from the growth of dendrites and the shrinkage of the metal on solidification.

The Special Summary Report will be written next and include a comprehensive review of adhesion-cohesion phenomena observed by the team of investigators

7. EVALUATION AND RECOMMENDATIONS

Although the calculated σ values for the seven liquid metal/vapor interfacial energies appear rational, it is difficult to determine if they are accurate. It is probable that they are not accurate since many experimental objections can be raised.

The drops are not symmetrical, but are graphically averaged to a symmetrical data set.

Symmetry and prevention of interaction with the substrate may be obtained by floating the sessile drop on a gas bearing formed by inert gas flowing through a slightly concave porous refractory substrate. This was attempted at this laboratory with liquid Hg on a glass frit at room temperature with success.

The drop shape is obtained by self-luminous light, which implies that it is seen against a dark background and is not in an isothermal or vapor saturated condition. Future work should consider use of a strong regimented or collimated (monochromatic) back light and a (monochromatic) filter on the camera to filter out self-luminous light. A violet gas laser back light is probably best. That will reduce the error due to the optical illusion problem of the highly reflective liquid metal surface.

The drop and alumina substrate should be in an enclosure like a Knudsen cell to obtain vapor saturation and isothermal temperature conditions essential for equilibrium vaporization/condensation at the liquid surface. That will help control the possible enrichment or depletion of the surface film in certain trace impurities, and the bulk composition will be more representative of the surface composition.

The use of monitored, purified hydrogen atmosphere to reduce surface oxide film residue will help eliminate "floating islands" of oxide which swim around the liquid metal surface and affect its surface energy. They may react with the substrate and affect the contact angle. After reducing the surface, the system should be evacuated so that the cell is saturated by the alloy vapor at its equilibrium vapor pressures.

The above recommendations for future experimental approach are simply based upon an extrapolation from the successful sessile drop work at ordinary temperatures. They have produced accurate and precise values of surface energy for liquid mercury and many polar liquids.

An independent experimental technique, such as are available at normal temperatures, is required to test the accuracy of high temperature sessile drop measurements.

8. PHASE C SUMMARY

A separate Special Summary Report is in preparation which will make a comprehensive review of all adhesion-cohesion phenomena by all investigators on Experiments M551, 552 and 553. Flight and ground base data and observations will be compared to identify significant zero gravity effects. A brief summary of the most significant effects is given here.

Experiment M551 (Metals Melting). The light battery powered, 2 kilowatt EB welder unit operated satisfactorily in the Skylab. It was designed and built by Westinghouse. The most significant result of this experiment was to prove it is both feasible and practical to do EB welding and cutting in zero gravity conditions. Assembly or repair of structures in space are possible. Equal success was seen with Al 2219, SS 304 and pure Ta metals, thus covering a broad range of useful metals. Both EB "bead-on-plate" welding and cutting were performed automatically.

Adhesion of the melted metals to the adjacent solid metals, and cohesion of the liquid metal to itself appeared to be equally as strong in zero gravity as on earth. Similar cut edge bead periodicity in cut thin plate, and similar periodic "chevron" patterns in full penetration welds were seen. Weight losses are generally insignificant and indicate no wet metal spattering to form droplets.

No microtensile strength measurements were made. However, microstructure examination showed similar metallurgical structures and porosity between zero gravity and ground base specimens. All evidence of solidification effects and movie pictures indicate strong convection currents during welding. Analysis indicates that bulk flow of the liquid (e.g., "sloshing" or cutting) results primarily from a mechanical reaction to vaporization opposed by restoring surface energy forces (surface tension). Convection in the liquid occurs both by bulk flow of the liquid and by a powerful surface energy driven (Marangoni) convection resulting from large thermal gradients in the liquid. Thus, even in the absence of gravity driven (density gradient) convection, strong convection flows occurred. No zero gravity effect on solidification of "bead-on-plate" welds was seen.

The surface energy of SS 304 alloy (0.08% carbon) in contact with its vapor was measured at four temperatures from melting point to 2058°K. It shows a strong temperature dependence.

Although the Experiment M551 was not intended to test weld design configuration, indications are that similar designs and tolerances are required for successful welds in zero gravity.

Further work on comparing the strengths of weld between zero and one gravity is recommended.

Experiment M552 (Exothermic Brazing). The NASA Exothermic Braze unit 95M10 100 operated 4 times with success on Skylab, producing excellent brazing thermal cycles. The braze unit has its own chemical (thermite) energy and only requires an electrical pulse for ignition.

The most significant practical result is that the design of braze joints for near zero gravity can be very tolerant of dimensional gaps in the joint. This conclusion is based on a comparison of narrow, wide and variable gap widths. Brazing is very practical as a joining or repairing technique for metal structures at zero gravity. The rapid heating rate obtained with exothermic heating was shown to produce excellent wetting and spreading of the Ag-Cu-Li braze alloy (Lithobraze BT 720).

The most interesting scientific result was the first use of radioisotope tracer techniques in the zero gravity of space. The techniques of mapping the braze alloy flow through the braze joint gaps were developed by the Division of Isotopes at the Oak Ridge National Laboratory. The Ag-110 activity profile showed increased rate and extent of braze alloy flow and spreading in zero gravity, thus greatly extending the scope of brazing over that possible on earth. Brazing is based on the wetting and spreading of liquid braze alloys through capillarity. On earth the capillary pumping action is opposed by gravity. In zero gravity, the amount of liquid braze alloy spread and pumped into a joint gap seems to be limited only by the amount of braze provided and the heating cycle. Many joints which would be welded on earth, would be brazed in zero gravity conditions. Finally, the uniformity of spreading and the menisci (liquid/vapor interfaces) were more uniform in zero gravity, perhaps as a result of a lack of the resistance of gravity.

Experiment M553 (Sphere Forming). The operation of the hardware developed to locate successive small (0.6 cm) diameter cylinders in the focus of the battery powered EB unit, melt the various metal specimens and deploy some liquid metal drops to drift in space, was generally successful. However, the sphericity and surface roughness were far from those of ball bearings.

The deployed liquid drops contacted a solid surface before solidifying, and flat spots resulted. Some had unmelted metal or alumina solids included. Still, definite differences in the secondary dendrite arm spacing (circa 10X smaller) occurred in the "cap" surface region last to solidify in the case of pure nickel. This is evidence of less convection flow as the last liquid metal solidifies in zero gravity. One drop developed a large central shrinkage void which was predicted by a idealized sphere solidification model.

9. REFERENCES

1. Bashforth, F. and Adams, J. C. : An Attempt to Test the Theories of Capillary Action. Cambridge University Press, 1883.
2. Butler, J. N. and Bloom, B. H. : A Curve-Fitting Method for Calculating Interfacial Tension from the Shape of a Sessile Drop. *Surface Science*, 4, 1966.
3. Fowkes, M. (ed): Contact Angles, Wettability and Adhesion. Advances in Chemistry Series, 43. American Chemical Society, Washington, D.C., 1964.
4. Kingery, W. D. and Humenik, M. : Surface Tension at Elevated Temperatures; Part I. Furnace and Method for Use of the Sessile Drop Method. *J. Phys. Chem.*, 57, p. 359, 1953.
5. Beer, S. Z. : Liquid Metals. Dekker, Syracuse, New York. 1972.
6. Schumacher, B. W., Private Communication.
7. Askar'yan, G. A. and Moroz, E. M. : *J. Exptl. Theoret. Phys. (U.S.S.R.)* 43, 2319-2320, 1962.
8. Wells, O. C. : A Note on the Physical Principles Underlying the Formation of the Cavity in Electron Beam Welding. Proc. of Fourth Symp. on Electron Beam Technology, Alloyed Electronics Corp., 1962.
9. Allen, B. C. and Kingery, W. D. : Surface Tension and Contact Angles in Some Liquid Metal-Solid Ceramic Systems at Elevated Temperatures. *Trans. AIME*, 215, 30, 1959.
10. Cox, Charles, Vice-President - Metallurgy and Ceramics, Handy-Harmon Co., A private communication.
11. Kurkjian, C. R. and Kingery, W. C. : Surface Tension at Elevated Temperatures; Part III, Effect of Cr, In, Sn and Ti on Liquid Nickel Surface Tension. . . . *J. Phys. Chem.*, 60, 961, 1956.
12. Taylor, J. W. : Wetting By Liquid Metals. Progress in Nuclear Energy Series V, Finnieston, H. M. and Howe, J. P. (editors), Pergamon Press, New York, 1959.