

NASA CR-134598



FRACTURE CONTROL METHODS FOR SPACE VEHICLES

Volume III

Space Shuttle Configurations

By
A.F. Liu and E.J. Mulcahy

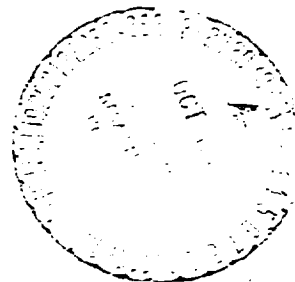

Prepared for

NATIONAL AERONAUTICS AND SPACE ADMINISTRATION

NASA Lewis Research Center
Contract NAS 3-16765

N74-35281

Unclas
51054

G3/31

(NASA-CR-134598) FRACTURE CONTROL METHODS
FOR SPACE VEHICLES. VOLUME 3: SPACE
SHUTTLE CONFIGURATIONS Contractor Report,
Jun. 1972 (Rockwell International Corp.,
Downey, Calif.) 235 p HC \$14.75 CSCL 22B

**FRACTURE CONTROL METHODS
FOR
SPACE VEHICLES**

**Volume III
Space Shuttle Configurations**

by

A. F. Liu and E. J. Mulcahy

**Contract NAS3-16765
NASA Lewis Research Center
Cleveland, Ohio**

August 1974

1. Report No. NASA CR-134598		2. Government Accession No.		3. Recipient's Catalog No.	
4. Title and Subtitle Fracture Control Methods for Space Vehicles, Volume III: Space Shuttle Configurations				5. Report Date August 1974	
7. Author(s) A.F. Liu and E.J. Mulcahy				6. Performing Organization Code	
9. Performing Organization Name and Address Space Division Rockwell International Corporation Downey, CA 90241				8. Performing Organization Report No. SD 73-SH-0171-3	
12. Sponsoring Agency Name and Address National Aeronautics and Space Administration 21000 Brookpark Rd. Lewis Research Center, Cleveland, OH 44135				10. Work Unit No.	
				11. Contract or Grant No. NAS3-16765	
				13. Type of Report and Period Covered Contractor Report June 1972 through March 1974	
15. Supplementary Notes Project Manager, Gordon T. Smith NASA Lewis Research Center Cleveland, OH 44135				14. Sponsoring Agency Code	
16. Abstract This volume contains Space Shuttle configuration drawings supplementary to the Space Shuttle structure described in Volume I.					
17. Key words (Suggested by Author(s)) Fracture Mechanics Space Vehicle Structure Fracture Control Procedures				18. Distribution Statement Unclassified, Unlimited	
19. Security Classif. (of this report) Unclassified		20. Security Classif. (of this page) Unclassified		21. No. of Pages	22. Price*

FOREWORD

The work described in this report was performed by the Space Division of Rockwell International Corporation under Contract NAS3-16765, Fracture Control Methods for Space Shuttle Vehicles, for the Lewis Research Center of the National Aeronautics and Space Administration. The investigation was conducted under the technical direction of Mr. Gordon T. Smith of NASA/LeRC. The project study manager at the Space Division of Rockwell International Corporation was Mr. A. F. Liu, with Dr. Paul C. Paris of Del Research Corporation and Dr. Matthew Creager of Del West Associates, Inc., acting as primary technical consultants.

This report consists of three volumes:

- Volume I. Fracture Control Design Methods (prepared by A. F. Liu)
- Volume II. Assessment of Fracture Mechanics Technology for Space Shuttle Applications (prepared by R. M. Ehret)
- Volume III. Space Shuttle Configurations (prepared by A. F. Liu and E. J. Mulcahy)

Mr. James E. Collipriest, Jr., provided overall technical guidance in the preparation of Volume II. Mr. Edward J. Mulcahy and Mr. A. S. Musicman contributed significantly to the preparation of Section 1.1 (Space Shuttle Vehicle Structural Description) of Volume I. Mr. John Mamon and Mr. F. Stuckenberg aided substantially in the preparation of the nondestructive evaluation sections in Volumes I and II. Mr. R. E. O'Brien and Mr. R. M. Ehret contributed, respectively, Section 2.2 (Prevention of Cracks and Crack-Like Defects in Shuttle Vehicle Structure) and Section 2.3.8 (Required Material Properties Data for Space Shuttle Fracture Mechanics Analysis) of Volume I. Dr. Matthew Creager contributed Section 2.3.6 (Failure Under Complex Loading Conditions) and Section 2.3.7.4 (Damage Tolerance Analysis for Pressure Vessels of Volume I and Section 2.2 (Thin Sheet Behavior) and a discussion of fracture behavior under combined in-plane loading in Section 1.2 (Linear Elastic Concepts of Fracture Behavior) of Volume II.

Mr. R. W. Westrup prepared the original proposal response to the RFP and established the basic frame work for the study program. The managerial guidance provided by Mr. R. P. Olsen, Engineering Manager, Materials and Processes, Space Division, is acknowledged by the authors.

This volume consists of the preliminary design drawings for the Space Shuttle vehicle structural components. The drawings represent the preliminary design configurations as of (on or before) June 1973.

Figures 1.1.1 to 1.1.4 present the general configuration and locations for major structural components. Figures 1.2.1 to 1.2.3 illustrate the structural parts for the solid rocket booster, and Figure 1.3.1 represents the external tank.

The Space Shuttle orbiter is conveniently divided into six component assemblies:

1. Mid fuselage (Figures 1.4.1 to 1.4.12)
2. Wing (Figures 1.5.1 to 1.5.4)
3. Forward fuselage and crew compartment (Figures 1.6.1 and 1.6.2)
4. Aft fuselage (Figures 1.7.1 to 1.7.5)
5. Vertical stabilizer (Figures 1.8.1 to 1.8.4)
6. Landing gear (Figures 1.9.1 and 1.9.2)

The maintenance accesses are shown in Figures 1.10.1 to 1.10.5.

ILLUSTRATIONS

Figure		Page
1.1.1	Space Shuttle System	1
1.1.2	Space Shuttle System	2
1.1.3	Space Shuttle System	3
1.1.4	Space Shuttle System	4
1.2.1	Solid Rocket Motor Assembly	5
1.2.2	Solid Rocket Motor Forward Skirt	6
1.2.3	Solid Rocket Motor Case	7
1.3.1	External Tank Structural Assembly	8
1.4.1	Mid Fuselage Structure	9
1.4.2	Mid Fuselage Side Panels	10
1.4.3	Mid Fuselage Side Panels	11
1.4.4	Mid Fuselage Lower Aft Longerons	12
1.4.5	Mid Fuselage Lower Aft Longerons	13
1.4.6	Mid Fuselage Lower Aft Skin Panels	14
1.4.7	Mid Fuselage Wing Carry-Through Torque Box	15
1.4.8	Mid Fuselage Lower Skin Panels	16
1.4.9	Mid Fuselage Lower Skin Panels	17
1.4.10	Mid Fuselage Main Landing Gear Support Structure	18
1.4.11	Mid Fuselage Main Landing Gear Support Structure	19
1.4.12	Mid Fuselage Payload Bay Doors	20
1.5.1	Wing Structure Subsystem Structural Arrangement	21
1.5.2	Wing Assembly Rib Construction	22
1.5.3	Wing Assembly Spar Construction	23
1.5.4	Elevon Assembly Construction	24
1.6.1	Forward Fuselage Structure	25
1.6.2	Cabin Structure	26
1.7.1	Aft Fuselage Structural Arrangement	27
1.7.2	Main Engine Thrust Support Structure	28
1.7.3	Main Engine Thrust Support Structure	29
1.7.4	Main Engine Thrust Support Structure	30
1.7.5	Main Engine Thrust Support Structure	31
1.8.1	Vertical Stabilizer Fin Assembly	32
1.8.2	Vertical Stabilizer Leading Edge Assembly	33
1.8.3	Vertical Stabilizer Rudder Assembly	34
1.8.4	Vertical Stabilizer Tip Assembly	35
1.9.1	Main Landing Gear	36
1.9.2	Nose Landing Gear	37

Figure		Page
1.10.1	Shuttle Area Zone Breakdown	38
1.10.2	Shuttle Maintenance Access	39
1.10.3	Shuttle Maintenance Access	40
1.10.4	Shuttle Maintenance Access	41
1.10.5	Shuttle Maintenance Access	42

America's Space Shuttle transportation system is paramount in furthering this country's knowledge—bringing our tremendous advancements in space sciences back to Earth as direct benefit to all.

The Shuttle orbiter—the delta-winged flying machine about the size of a medium-range jet—is reusable, cargo-carrying, space airplane with workhorse capabilities. Each Shuttle orbiter can fly

REPRODUCIBILITY OF THE ORIGINAL PAGE IS POOR

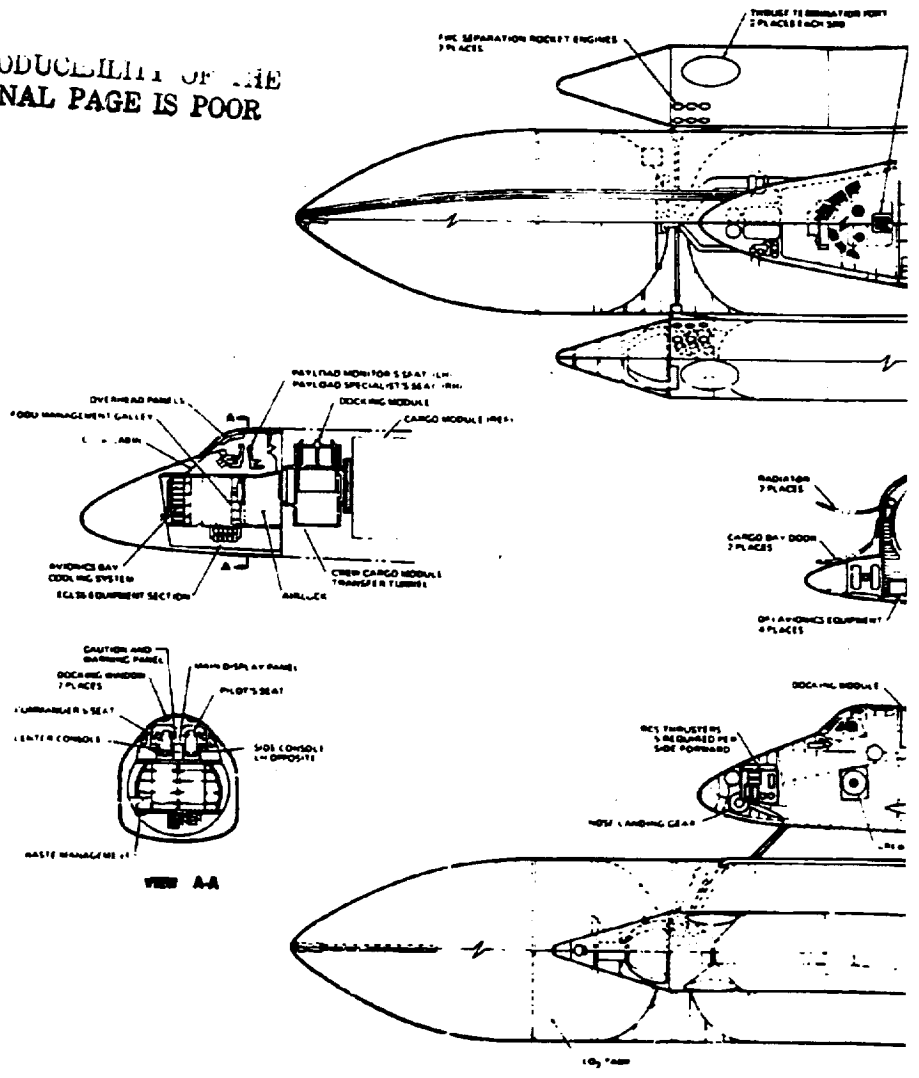

FOLDOUT FRAME

country's scientific
direct benefits to us

range jetliner—is a
can fly a minimum

of 100 missions and can carry to orbit as much as 65,000 pounds of payload and up to four crew members and six passengers. It can return 25,000 pounds of payload to Earth.

Rockwell International Corporation's Space Division is integrating the system and developing the Shuttle's payload-carrying orbiter stage under contract to the National Aeronautics and Space Administration.

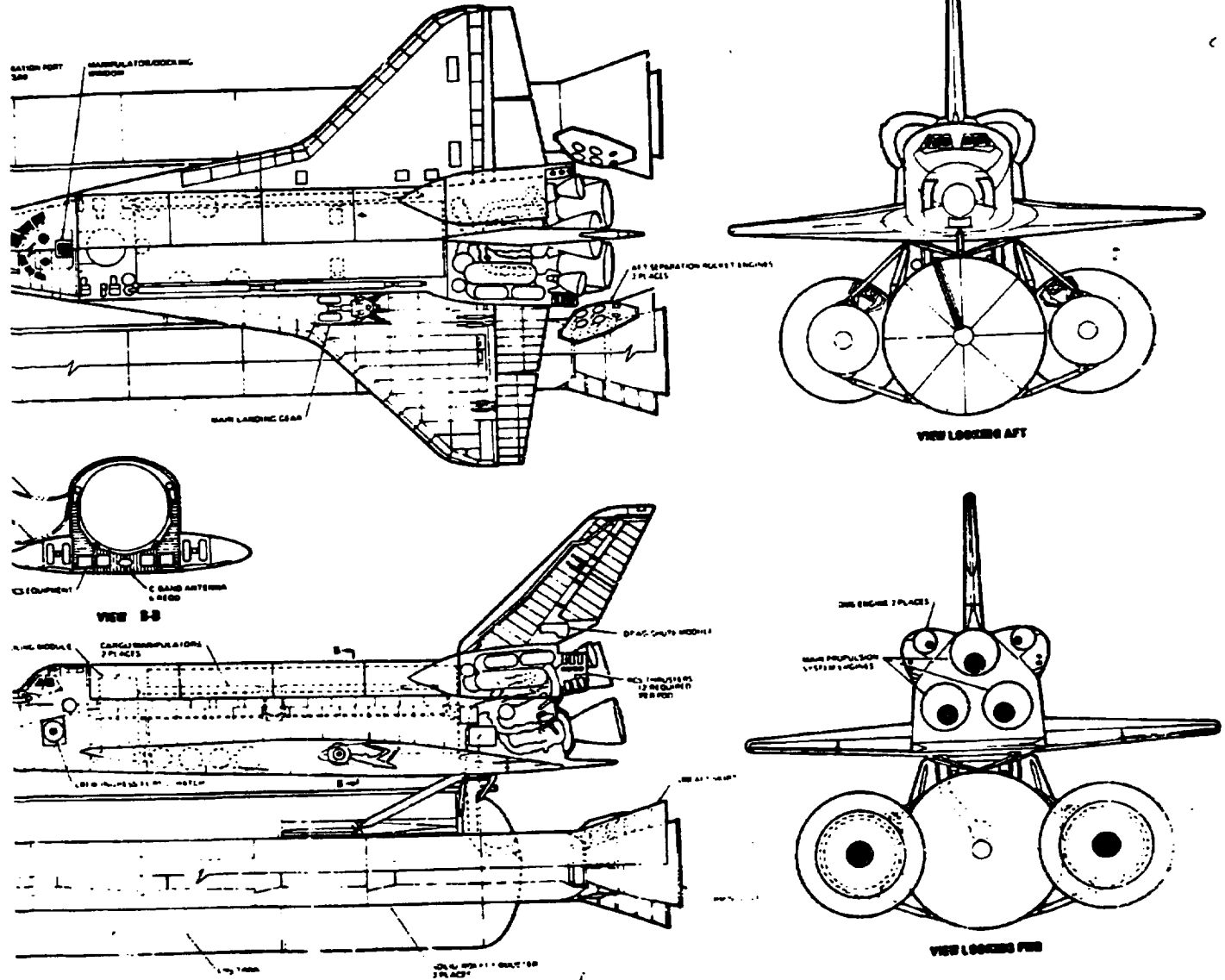
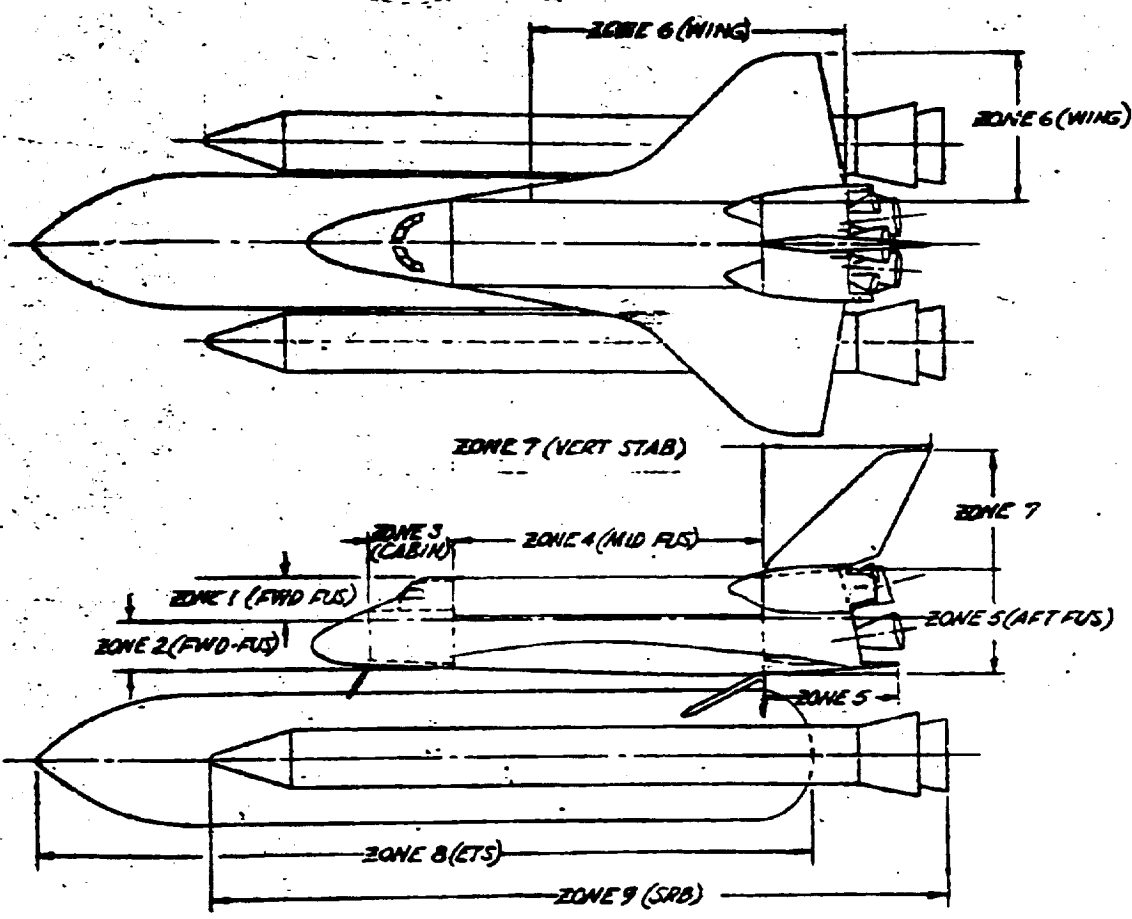

Figure 1.1.1. Space Shuttle System

REPRODUCIBILITY OF THE
ORIGINAL PAGE IS POOR



SHUTTLE AREA ZONE BREAKDOWN

REPRODUCIBILITY OF THE ORIGINAL PAGE IS POOR

SYSTEMS & EQUIPMENT			SYSTEMS		
NUMBER	NOMENCLATURE	REF DWG	ZONE	NUMBER	NOM
	SRM BOOSTER	VL77-000035			
901	SRB NOSE CONE		7	708	ORBITER - VERT.
902	SRB NOSE CONE CORK ABULATOR			709	DECELERATION C
903	MORTAR SHROUD PILOT CHUTE & RISER			710	DECELERATION C
904	MAIN PARACHUTE (96 FT DIA) 6 REQ'D			711	DECELERATION C
905	DROGUE CHUTE (62 FT DIA) 1 REQ'D			712	RUDDER/SPEED
906	DROGUE CHUTE RISER, ATTACH & DISC			713	RUDDER/SP BRK
907	NOSE CONE SEP RELEASE			714	VERT APU EXHAU
908	AVIONICS EQUIPMENT			715	VERT LH ₂ EMERG
910	RECOVERY EQUIP - SEQUENCER, BATTERY & FLASHLIGHT			716	APU VENT DUC
911	FWD SEP ROCKET ENG (4 REQ'D PER SRB)			717	DUAL MOTOR
912	THRUST TERMINATION PORT (2 REQ'D PER SRB)		8	802	RUDDER ACTU
913	SRB AFT SKIRT			803	ORBITER MAIN PR
914	SRM NOZZLE			804	ETS LH ₂ SE FLU
915	GIMBAL HYD ACT (2 REQ'D PER SRM)			805	LOX TANK OVER
916	GIMBAL ACT HYD RESERVOIR (6.5 IN DIA) 1 PER SRM			806	LOX TANK GAS
917	GIMBAL ACT PRESS TANKS (18 IN DIA) 2 PER SRM			807	LOX TANK PROX
918	AFT SEP ROCKET ENG (4 REQ'D PER SRB)			808	CRUCIFORM BUFF
919	NOSE CONE ATTACH BOLTS	VL77-000035		809	ANTI-VORTEX B
				810	LOX FEEDLINE O
				811	LOX AFT TANK
				812	SEP SEQUENCE
				813	ETS - SRB ATT
				814	ETS - SRB ELEC
				815	ETS - SRB ELEC
				816	MULTIPLEXER
				817	BATTERIES - 6
				818	LH ₂ TANK GAS
				819	LH ₂ TANK PROX
				820	LH ₂ FEEDLINE
				821	MPS ENG CUT
				822	ETS TANK G
				823	LOX OVERBOARD
					LH ₂ TANK OVE
					ETS LOX SE

REPRODUCIBILITY OF THE ORIGINAL PAGE IS POOR

FRAME

2

13 VL77-000091 511

SYSTEMS & EQUIPMENT		SYSTEMS & EQUIPMENT	
NOMENCLATURE	REF DWG	ZONE	NUMBER
-VERTICAL STABILIZER	VL70-007017	5	530
ATION CHUTE STOWAGE COMP			531
ATION CHUTE			532
ATION CHUTE MORTAR			533
SPD BRAKE HINGE			
SP BRK ELECT HARNESS & DISC			
EXHAUST DUCT			
EMERG VENT LINE & FLAME HOLDER			
NT DUCT		6	617
MOTORS	VL70-007017		618
ACTUATOR			601
MAIN PROP SYS-EXTERNAL TANK SYS	VL70-000091		602
SE PURGE LINE			603
OVERBOARD VENTS			604
GAS DIFFUSER			605
PROP LOADING PT SENSORS			607
BAFFLE			608
TEX BAFFLE			609
LINE OUTLET CONICAL SCREEN			610
TANK LOADING SENSORS			611
QUENCER (2 REQ'D)			612
RB ATTACH FITTINGS (2 REQ'D)			613
B ELECT UMBIL & HARNESS NO. 1			614
B ELECT UMBIL & HARNESS NO. 2			615
PLEXER & SIG COND (2 REQ'D)		616	
RIES-LOGIC/PWR (2 REQ'D)			
GAS DIFFUSER			
PROP LOADING PT SENSORS			
EDLINE OUTLET SCREEN			
NG CUTOFF PT SENSORS			
ARK GA ₂ CAVITY PURGE LINE			
BOARD VENT VLV			
OVERBOARD VENT LINE			
SE PURGE LINE			
		7	701
			702
			703
			704
			705
			706
			707

REPRODUCIBILITY OF THE ORIGINAL PAGE IS POOR

FRAME

ENT		SYSTEMS & EQUIPMENT			
REF DWG	ZONE	NUMBER	NOMENCLATURE	REF DWG	
VL70-005030	5		ORBITER-AFT FUSELAGE	VL70-005030	
		550	WING HYDR INTERFACE PNL NO.2		
		551	MPS ENG HYD. ACTUATOR (2 PER ENG)		
		552	MPS ENG HT SHIELD (3 REQ'D)		
		553	APU EXHAUST DUCT		
		554	APU TURBOPOWER UNIT (4 PLACES)		
		555	APU GENERATOR (4 PLACES)		
VL70-006077		556	HYD RELIEF WY-FILTER MODULE (4 PL)		
		557	HYD RESERVOIR (4 PLACES)		
		559	HYD CIRCULATION MTR PUMP		
		560	HYD WATER BOILER (4 PLACES)		
		561	HYD AIR/OIL COOLER (4 PLACES)		
		562	HYD ACCUM (4 PLACES)		
		563	APU FUEL (N ₂ H ₂) TANK (4 REQ'D)		
		564	APU HELIUM TANK (4 REQ'D)		
		565	APU TANK FILL DRAIN & VENT RECEIPT		
		566	APU VLV BLEED DUCT		
		567	RADIATOR CONTROL PNL	VL70-005030	
		568	OMS POD ATTACH FITTINGS	VL70-005076	
		569	OMS HELIUM TANK (2 REQ'D)		
		570	OMS FUEL TANK (2 REQ'D)		
		571	OMS FUEL TANK VENT		
		572	OMS OXIDIZER TANK (2 REQ'D)		
		573	OMS OXIDIZER TANK VENT		
		574	OMS ENG NO. 1		
		575	OMS ENG NO. 2		
VL70-007017		576	DELTA V KIT CROSSOVER LINE DISC		
		577	RCS THRUSTERS (12 PER POD)		
		578	RCS PROPELLANT TANK (2 PER POD)		
		579	RCS HELIUM TANK (2 REQ'D)	VL70-005076	
		580	MPS ENG NO. 1	VL70-005030	
		581	MPS ENG NO. 2		
		582	MPS ENG NO. 3		
VL70-007017		583	MPS ELECT WIRING & DISC	VL70-005030	

REPRODUCIBILITY OF THE ORIGINAL PAGE IS POOR

FRAME

REF DWG	SYSTEMS & EQUIPMENT			REF DWG
VL70-008030	ZONE NUMBER	NOMENCLATURE	VL70-008030	ZONE N
	5	ORBITER - AFT FUSELAGE		5
	506	AVIONICS BAY NO. 4 (34 X 44.5 X 36)		
	507	AVIONICS BAY NO. 5 (34 X 44.5 X 36)		
	508	AVIONICS BAY NO. 6 (34 X 44.5 X 36)		
	509	PAYLOAD FUEL INTERFACE PNL		
	520	MPS LH ₂ RECIRC. PUMP		
	521	MPS LH ₂ UMBILICAL PNL		
	522	MPS LH ₂ FILL & DRAIN DISC		
	523	MPS LH ₂ TANK HELIUM PRE-PRESS DISC		
	524	MPS LH ₂ TANK VENT DISC		
	525	MPS STATIC GRD JACK		
	526	GN ₂ GRD PURGE VEHICLE CAVITIES DISC		
	527	GRD ELECT PWR DISC		
	528	SE FLYAWAY UMBIL COMM INSTR GN ₂ C		
	529	MPS LH ₂ DUMP LINE		
	531	MPS LOX UMBILICAL PNL		
	532	MPS LOX FILL & DRAIN DISC		
	533	MPS LOX TANK HELIUM PRE-PRESS DISC		
	530	MPS LOX DUMP LINE		
	535	MPS LOX OVERBOARD BLEED DISC		
	536	MPS HELIUM SUPPLY DISC		
	537	MPS GN ₂ ENGINE PURGE DISC		
	538	GRD ELECT PWR DISC		
	539	SE FLYAWAY COMM INSTR GN ₂ C		
	540	ETS-ORBITER AFT ATTACH MECH NO. 1		
	541	ETS-ORBITER AFT ATTACH MECH NO. 2		
	542	LH ₂ FEEDLINE EMERG VENT LINE		
	543	LOX PRESS LINE & DISC (2 IN. DIA)		
	544	PNEUMATIC SUBSYS HELIUM TANKS (3 RGT)		
	545	APU FUEL TANK MODULE NO. 1		
	546	APU FUEL TANK MODULE NO. 2		
	547	WING ELECT INTERFACE PNL NO. 1		
	548	WING ELECT INTERFACE PNL NO. 2		
	549	WING HYDR INTERFACE PNL NO. 1	VL70-008030	

REPRODUCIBILITY OF THE ORIGINAL PAGE IS POOR

WOLDOVE FRAME

5

-000091 SH 1

470 5

9

SYSTEMS & EQUIPMENT

ZONE	NUMBER	NOMENCLATURE	REF DWG	
4		ORBITER MID FUSELAGE	VL70-004032	
	494	ECLSS O ₂ SUPPLY DISC		
	495	ECLSS COOLANT INLET NO. 1		
	496	ECLSS COOLANT INLET NO. 2		
	497	ECLSS COOLANT RETURN NO. 1		
	498	ECLSS COOLANT RETURN NO. 2		
	499	ECLSS FUEL CELL LOX FILL NO. 1		
	490	ECLSS FUEL CELL LOX FILL NO. 2		
	491	ECLSS FUEL CELL LOX VENT NO. 1		
	492	ECLSS FUEL CELL LOX VENT NO. 2		
	493	FLOOD LIGHT (2 REQ'D)		
	494	TV CAMERA (2 REQ'D)		
	495	PURGE & VENT LINES		
	496	ECLSS HYD & ELECT PWR SYS LINES (LH & RH)		
	498	AFT FUS-WING ATTACH FITTING	VL70-004032	
	5		ORBITER-AFT FUSELAGE	VL70-005030
		501	MPS LH ₂ FEEDLINE	
		502	MPS LOX FEEDLINE	
		503	MPS ENG NO. 1 LH ₂ FEED MANIFOLD	
504		MPS ENG NO. 1 LOX FEED MANIFOLD		
505		MPS ENG NO. 2 LH ₂ FEED MANIFOLD		
506		MPS ENG NO. 2 LOX FEED MANIFOLD		
507		MPS ENG NO. 3 LH ₂ FEED MANIFOLD		
508		MPS ENG NO. 3 LOX FEED MANIFOLD		
509		WING PURGE DUCT (LH & RH REQ'D)		
510		FWD CARGO BAY PURGE DUCT (5 IN DIA)		
511		MPS LH ₂ RECIRC LINE		
512		MPS LH ₂ VENT / PRESS LINE & DISC		
513		MPS ORBITER-ETS ELECT HARNESS		
514		MPS ETS-ORB LOX DUCT SEP INTERFACE UNBIL		
515		MPS ETS-ORB LH ₂ DUCT SEP INTERFACE UNBIL	VL70-005030	

ZONE	NUMBER	NOMENCLATURE
4		ORBITER
	452	C-BAR
	453	C-BA
	454	EAAS
	455	MANI.
	456	MANI
	457	MANI.
	458	DOCK
	459	CARGO
	460	CARGO
	461	CARGO
	462	CARGO
	463	CARGO
	464	DAYLL
	465	FRYLL
	466	RADI
	467	RADI
	468	RADI
	469	RADI.
	470	RADI.
	471	RADI.
472	RADI.	
473	RADI.	
474	RADI.	
475	HT SI	
476	TRF 7	
477	CARG	
478	ECLS	
479	ECL	
480	ECL	
481	ECL	
482	ECL	
483	ECL	

SYSTEMS & EQUIPMENT	
NOMENCLATURE	REF DWG
ORBITER MID FUSELAGE	VL70-004838
C-BAND ANTENNA NO.5	
C-BAND ANTENNA NO.6	
CARGO SERVICING PNL NO.2	
MANIPULATOR	
ARMANIPULATOR NO.2	
MANIPULATOR LATCHES	
DOCKING MODULE	
CARGO BAY DOOR LATCHES (16 REQ'D)	
CARGO BAY DOOR HINGE ACT	
CARGO BAY DOOR HINGE DRIVE UNIT	
CARGO BAY DOOR HINGE	
CARGO BAY TORQUE TUBE	
PAYLOAD RESTRAINT ATTACH MECH.	
PAYLOAD RETENTION DRIVE UNIT	
RADIATOR PANEL NO.1	
RADIATOR PANEL NO.2	
RADIATOR PANEL NO.3	
RADIATOR PANEL NO.4	
RADIATOR PANEL NO.5	
RADIATOR PANEL NO.6	
RADIATOR PANEL NO.7	
RADIATOR PANEL NO.8	
RADIATOR PNL HINGES	
WT SINK INTAKE/OUTLET ORIFICE (10 PLACES)	
REF TUNNEL - CARGO MODULE	
CARGO MODULE (REF)	
ECLSS GROUND COOLANT CONN	
ECLSS GH ₂ SUPPLY DISC	
ECLSS FUEL CELL LH ₂ VENT NO.1	
ECLSS FUEL CELL LH ₂ VENT NO.2	
ECLSS HYDROGEN RELIEF	
ECLSS FUEL CELL LH ₂ FILL NO.1	
ECLSS FUEL CELL LH ₂ FILL NO.2	VL70-004838

SYSTEMS & EQUIP.		
ZONE	NUMBER	NOMENCLATURE
4	418	ORBITER MID FUSELAGE
	419	ECLSS BROWN VLV MODULE
	420	N ₂ MANIFOLD VLV MODULE A
	421	O ₂ MANIFOLD VLV MODULE
	422	N ₂ MANIFOLD VLV MODULE
	423	O ₂ MANIFOLD VLV MODULE
	424	BLKHD LINES FEED THROUGH U
	425	BLKHD LINES FEED THROUGH U
	426	BLKHD LINES FEED THROUGH U
	427	BLKHD LINES FEED THROUGH U
	428	ECLSS UMBILICAL PNL
	429	ECLSS UMBILICAL PNL NO.2
	430	CARGO SERVICING PNL
	431	L-BAND ANTENNA
	432	VHF ANTENNA
	433	WASTE MGT VACCUUM VENT
	434	AVIONICS BA:5 PRESS RELI.
	435	NITROGEN PRESS RELIEF
	436	WATER PRESS RELIEF
	437	BRINE DUMP NO.1
	438	URINE DUMP NO.2
	439	PGS SUPERCRITICAL LOX TA
	440	PGS SUPERCRITICAL LH ₂ TA
	441	PGS SUPERCRITICAL LOX TA
	442	PGS SUPERCRITICAL LH ₂ TA
	443	CARGO BAY LINER
	444	DFI AVIONICS EQUIP RACK NO.
	445	DFI AVIONICS EQUIP RACK NO.
	446	DFI AVIONICS EQUIP RACK NO.
	447	DFI AVIONICS EQUIP RACK N
	448	C-BAND ANTENNA NO.1
	449	C-BAND ANTENNA NO.2
	450	C-BAND ANTENNA NO.3
	451	C-BAND ANTENNA NO.4

7

REPRODUCIBILITY OF THE ORIGINAL PAGE IS POOR

ENT		SYSTEMS & EQUIPMENT			
	REF DWG	ZONE	NUMBER	NOMENCLATURE	REF DWG
	VL70-004032	3		<u>CREW CABIN</u>	
			367	WASTE COLLECTOR	VL70-004032
2.1			368	POTABLE WATER TANK NO. 1	
2.1			369	POTABLE WATER TANK NO. 2	
NO. 2			370	WASTE LIQUID SEP SYS	
NO. 2			371	ECLSS COOLANT PUMP SYS	
3/L NO. 1			372	WASTE WATER TANKS (3REQ'D)	
1B/L NO. 2			373	CABIN AIR RETURN DUCT	
1B/L NO. 3			374	CABIN AIR SUPPLY DUCT	VL70-004032
1B/L NO. 4			375	ELECT WIRING HARNESS & CONN	
		4		<u>ORBITER MID FUSELAGE</u>	VL70-004032
			401	ECLSS FUEL CELL PWR PLANT NO. 1	
			402	ECLSS FUEL CELL PWR PLANT NO. 3	
			403	ECLSS FUEL CELL PWR PLANT NO. 2	
			404	ECLSS PAYLOAD HT EXCHANGER	
VK NO. 1			405	ECLSS FREON PUMPS & ACCUM MODULE	
VK NO. 1			406	ECLSS SUBLIMATOR NO. 1	
VK NO. 2			407	ECLSS SUBLIMATOR NO. 2	
VK NO. 2			408	ECLSS FREON VLV MANIFOLD	
			409	ECLSS INTERCHANGER	
1			410	ECLSS FUEL CELL HT EXCH	
2			411	ECLSS FUEL CELL SERVICE PNL	
3			412	ECLSS GSE HT EXCH	
2.4			413	ECLSS HIGH PRESS O ₂ TANK NO. 1	
			414	ECLSS HIGH PRESS N ₂ TANK NO. 1	
			415	ECLSS HIGH PRESS N ₂ TANK NO. 2	
			416	ECLSS HIGH PRESS N ₂ TANK NO. 3	
	VL70-004032		417	EPS VLV MODULE (4)	VL70-004032

8

SYSTEMS & EQUIPMENT

ZLWE	NUMBER	NOMENCLATURE	REF DWG
5		<u>CREW CABIN</u>	
	334	PILOT'S DOCKING OBSERVATION WINDOWS	
	335	CMDS " " " " " "	
	338	PAYLOAD MONITOR DISPLAY PNL, SIDE	
	339	MISSION SPEC DISPLAY PANEL, SIDE	
	340	PAYLOAD MONITOR'S SEAT	
	341	MISSION SPECIALIST'S SEAT	
	342	PAYLOAD MONITOR VERT PNL	
	343	MISSION SPEC VERT PNL	
	344	PAYLOAD MONITOR CTR CONSOLE	
	345	PAYLOAD MONITOR LH SIDE CONSOLE	
	346	PAYLOAD MONITOR RH SIDE CONSOLE	
	347	CARGO MANIPULATOR CONTROLS	
	348	CARGO BAY OBSERVATION WINDOW	
	349	SPEED BRAKE CONTROL	
	350	ROTATION CONTROL LEVEL (2 REQ'D)	
	351	MASTER POWER CONTROL LEVEL	
	352	TRANSLATION CONTROL LEVEL	
	353	AVIONICS BAY NO. 3	
	354	AVIONICS BAY NO. 2	
	355	AVIONICS BAY NO. 1	
	356	AIRLOCK	
	357	WASTE MANAGEMENT & HYGIENE FAC	
	358	FOOD MANAGEMENT GALLEY	
	359	LIGH CANISTERS STORAGE (28 REQ'D)	
	360	LIGH CANISTERS ACTIVE (2 REQ'D)	
	361	CABIN TEMP CTRL & CO ₂ ABSORBER ASSY	
	362	AVIONICS BAY NO. 2 COOLING SYS	
	363	AVIONICS BAY NO. 1 COOLING SYS	
	364	AVIONICS BAY NO. 3 COOLING SYS	
	365	AVIONICS BAY AIR RETURN DUCT (4 REQ'D)	
	366	AVIONICS BAY AIR INLET DUCT (3 REQ'D)	

ZONE	NUMBER	
5		<u>CREW</u>
	301	CUPO
	302	CUPO
	303	CUPO
	304	CRT
	305	OVE
	306	OVE
	307	OVE
	308	MAIN
	309	CAUT.
	310	CENT
	311	LH
	312	RH
	313	DIS
	314	PIL
	315	CMD
	316	PILL
	317	CM
	318	TRN
	319	LH
	320	RH
	321	FLT
	322	DIS
	323	DIS
	324	CTRL
	325	CTRL
	326	RH
	327	LH
	328	RH
	329	LH
	330	OVE
	331	CAB
	332	FUS
	333	LH

REPRODUCIBILITY OF THE ORIGINAL PAGE IS POOR

DATE 9

205 1 3

SYSTEMS & EQUIPMENT

NOMENCLATURE

REF DWG

CREW CABIN
~~CUPOLA AFT OBSERVATION WINDOW~~
~~CUPOLA FWD OBSERVATION EMERG EGRESS HATCH~~
~~CUPOLA SIDE WINDOWS (LH & RH)~~
 CRT DISPLAY HOUSING (2 REQ'D)
 OVERHEAD AFT CONSOLE
 OVERHEAD FWD CONSOLE
 OVERHEAD EYEBROW CONSOLE
 MAIN DISPLAY PANEL
 CAUTION WARNING PANEL
 CENTER CONSOLE
 LH SIDE CONSOLE
 RH SIDE CONSOLE
 DISPLAY PROCESSOR (3 REQ'D)
 PILOT'S RUDDER PEDALS
 CMDR'S RUDDER PEDALS
 PILOT'S SEAT
 CMDR'S SEAT
 TRANSVERSE AIR DUCTING
 LH VERTICAL PANEL
 RH VERTICAL PANEL
 FLT CONTROL
 DISPLAY/COUPLER DRIVER UNIT (RH INSTL)
 DISPLAY/COUPLER DRIVER UNIT (LH INSTL)
 CTRL ENCODER/COUPLER UNIT (RH INSTL)
 CTRL ENCODER/COUPLER UNIT (LH INSTL)
 RH CIRCUIT BREAKER & SWITCH PNL
 LH CIRCUIT BREAKER & SWITCHES & CTRL
 RH SIDE CONSOLE SWITCHES & CONTROLS
 LH SIDE CONSOLE SWITCHES & CONTROLS
 OVERHEAD CONSOLE SW & CTRL UNIT
 CABIN INTERNAL WINDOWS
 FUSELAGE FWD THERMAL WINDOWS
 LH SIDE PANEL

! VLT0-003208
 VLT0-003217
 VLT0-003218

SYSTEMS & EQUIPMENT

NOMENCLATURE

ZONE NUMBER

ZONE	NUMBER	NOMENCLATURE	
1		ORBITER - UPPER FWD	
		RCS - FILL, DRAIN & VLV	
		INERTIAL MEASUREMENT	
		PILOT STATIC PRESS	
		STARTRACKER (3 REQ'D)	
		L-BAND ANTENNA (L)	
		C-BAND ANTENNA (L)	
		S-BAND ANTENNA (L)	
		OVERHEAD OBSERVATI	
		VHF ANTENNA NO.	
		VHF ANTENNA NO.	
		PILOT STATC PRESS	
	2		ORBITER - LOWER FWD
			NOSE LANDING GEAR
			ILS ANTENNA
			RCS THRUSTERS (8 REQ'D)
			RCS PROPELLANT T.
		RCS HELIUM TANKS (
		HATCH - OPEN TO CABIN	
		HATCH ACTUATOR AS	
		HATCH HINGE ASSY	
		HATCH LATCHES	
		HATCH MANUAL DRIV	
		S-BAND ANTENNA (
		S-BAND ANTENNA (
		AUDIO UMBIL PHONE	
	GROUND ELECT PWR CON		
	RCS MODULE ATTACH		
	NOSE RCS DEPLOY DOG		
	NOSE RCS PROP DISC		
	NOSE RCS VLV INSTL		

REPRODUCIBILITY OF THE ORIGINAL PAGE IS POOR

Figure 1. I-2. Space St

SYSTEMS & EQUIPMENT

ZONE	NUMBER	NOMENCLATURE	REF DWG
1		ORBITER - UPPER FWD FUSELAGE	VELD-00104B
	101	RCS - FILL, DRAIN & VENT RECEPTACLE	
	102	INERTIAL MEASUREMENT UNIT	
	103	PITOT STATIC PRESS TUBE NO. 1	
	104	STARTRACKER (3 REQ'D)	
	105	L-BAND ANTENNA (LH SIDE)	
	106	G-BAND ANTENNA (RH SIDE)	
	107	S-BAND ANTENNA (LH SIDE)	
	108	S-BAND ANTENNA (RH SIDE)	
	109	OVERHEAD OBSERVATION WINDOW	
	110	VHF ANTENNA NO. 2	
	111	VHF ANTENNA NO. 1	
	112	PITOT STATIC PRESS TUBE NO. 2	
	2		ORBITER - LOWER FWD FUSELAGE
201		NOSE LANDING GEAR & SYSTEMS	
202		ILS ANTENNA	
203		RCS THRUSTERS (8 REQ'D PER SIDE)	
204		RCS PROPELLANT TANKS (4 REQ'D)	
205		RCS HELIUM TANKS (2 REQ'D)	
206		HATCH - CREW TO CABIN INGRESS/EGRESS	
207		HATCH ACTUATOR ASSY	
208		HATCH HINGE ASSY	
209		HATCH LATCHES	
210		HATCH MANUAL DRIVE GEAR BOX	
211		S-BAND ANTENNA (LH SIDE)	
212		S-BAND ANTENNA (RH SIDE)	
213		AUDIO UMBIL PHONE JACK	
214		GROUND ELEC PWR CONN	
215		RCS MODULE ATTACH BOLTS	
216		NOSE RCS DEPLOY DOOR HINGES	
217		NOSE RCS PROP DISC	
218		NOSE RCS VLV INSTL	

Figure 1.1.2. Space Shuttle System

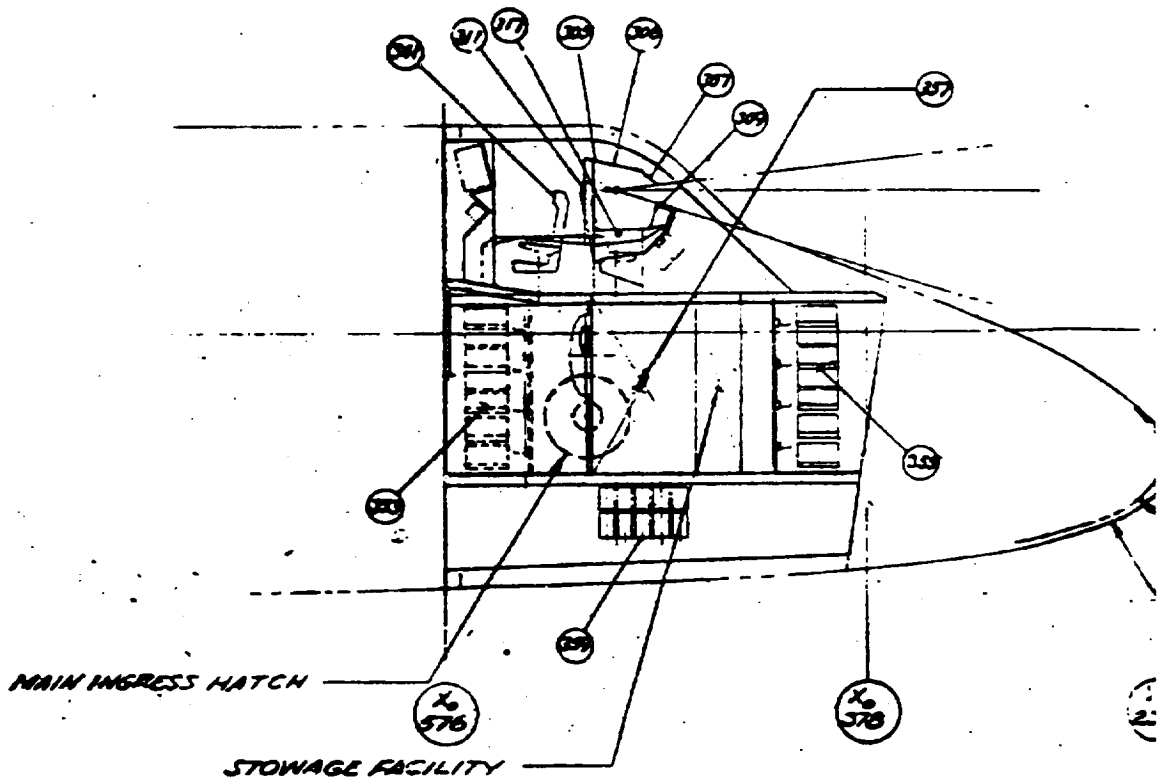

VIEW F - F 32

REPRODUCIBILITY OF THE ORIGINAL PAGE IS POOR

IT FRAME

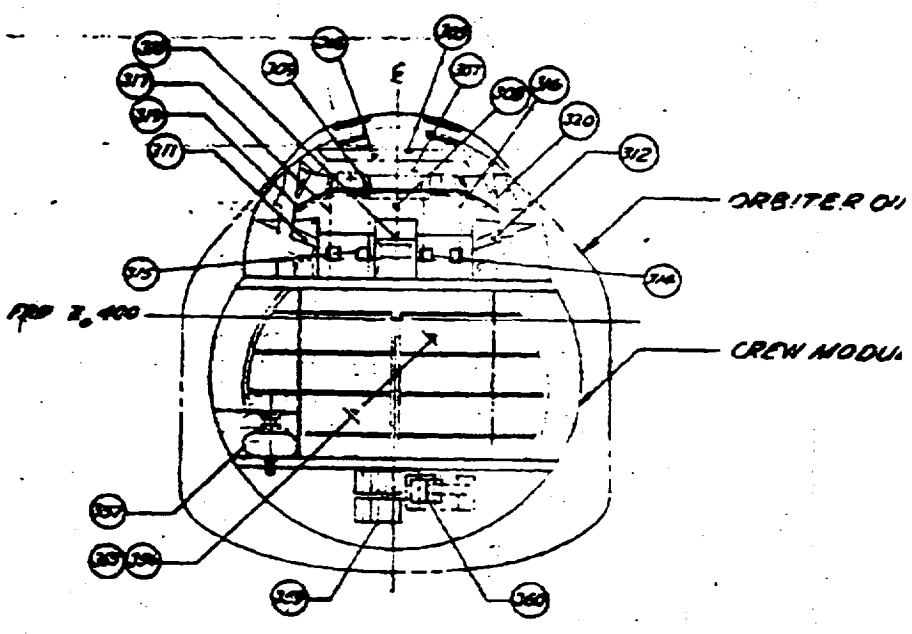
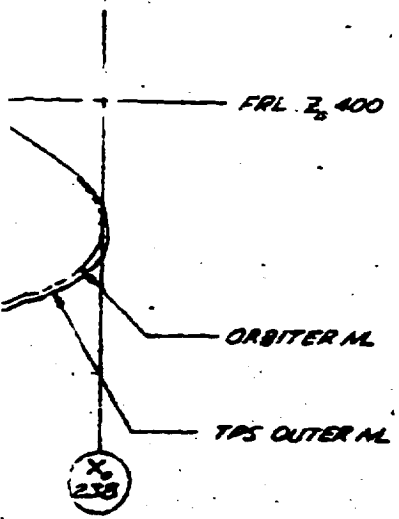

VIEW H-H 26

REPRODUCIBILITY OF THE ORIGINAL PAGE IS POOR

FOLDOUT FRAME

2

ORBITER OUTER TPS M. AT STA X₀500 REF

REW MODULE M. AT STA X₀500

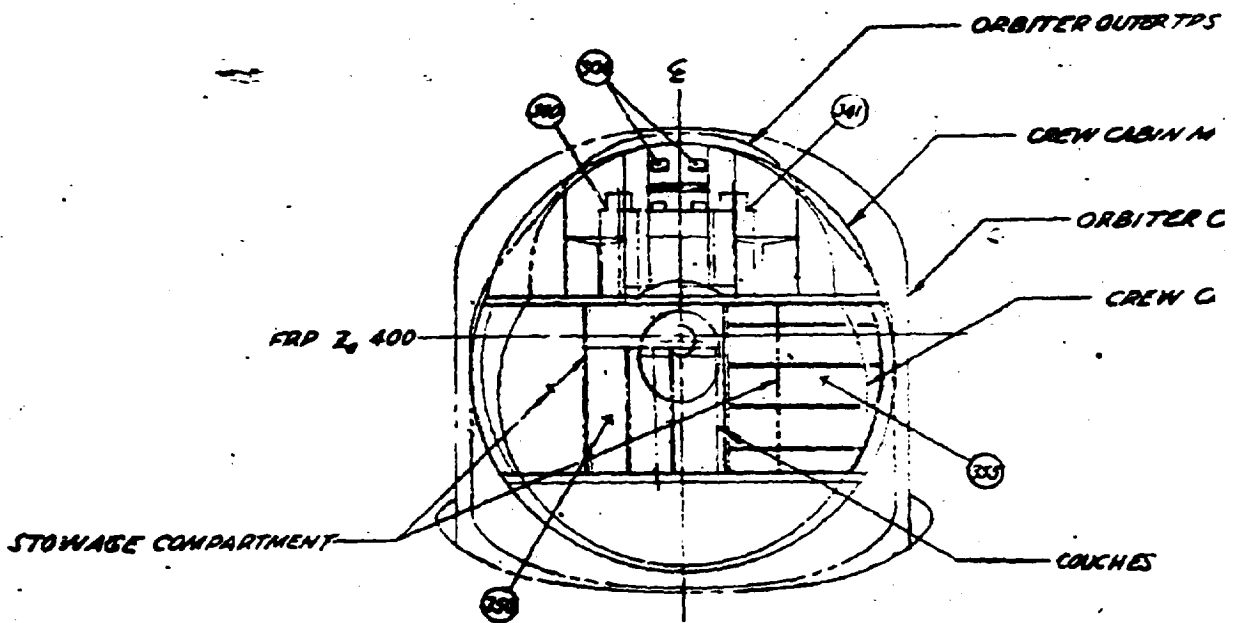

VIEW G-G ES

REPRODUCIBILITY OF THE ORIGINAL PAGE IS POOR

ORBITER FRAME

5

TPS ML REF @ STA X₀ 500

MODULE ML AT STA X₀ 576

ROUTER TPS ML REF AT X₀ 560

CABIN MODULE ML AT STA X₀ 500

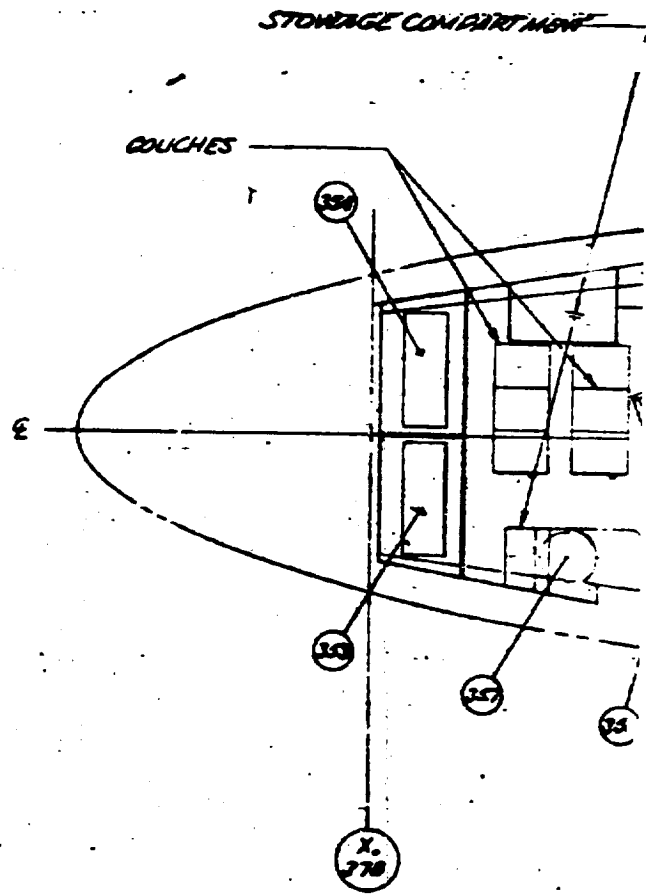

VIEW E-E

REPRODUCIBILITY OF THE ORIGINAL PAGE IS POOR

UP FRAME

4

FLIGHT

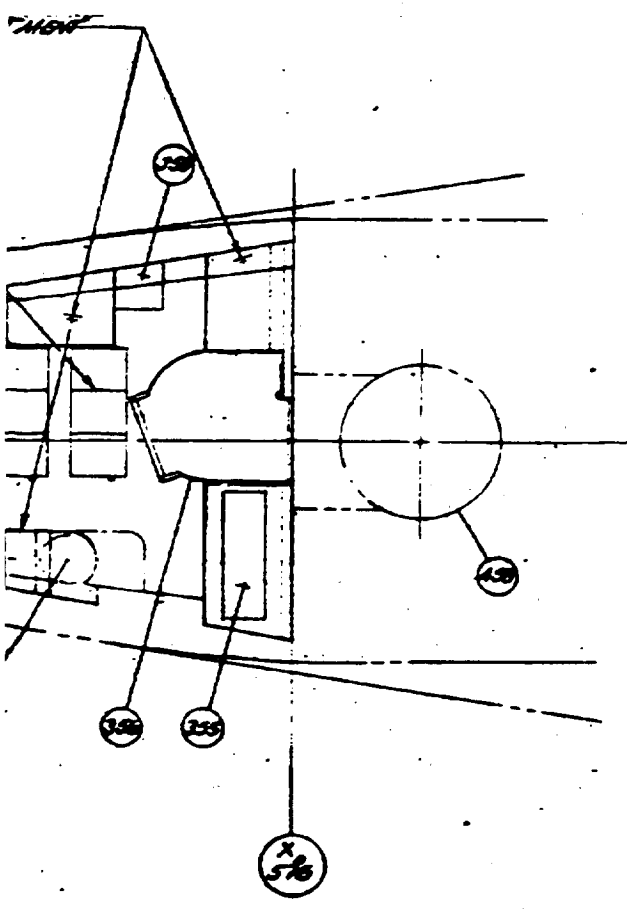

ACCESS OPENING FROM MID
AFT MAIN INSTR PNL

FRL 2,400

REPRODUCIBILITY OF THE
ORIGINAL PAGE IS POOR

DUE TRAVE

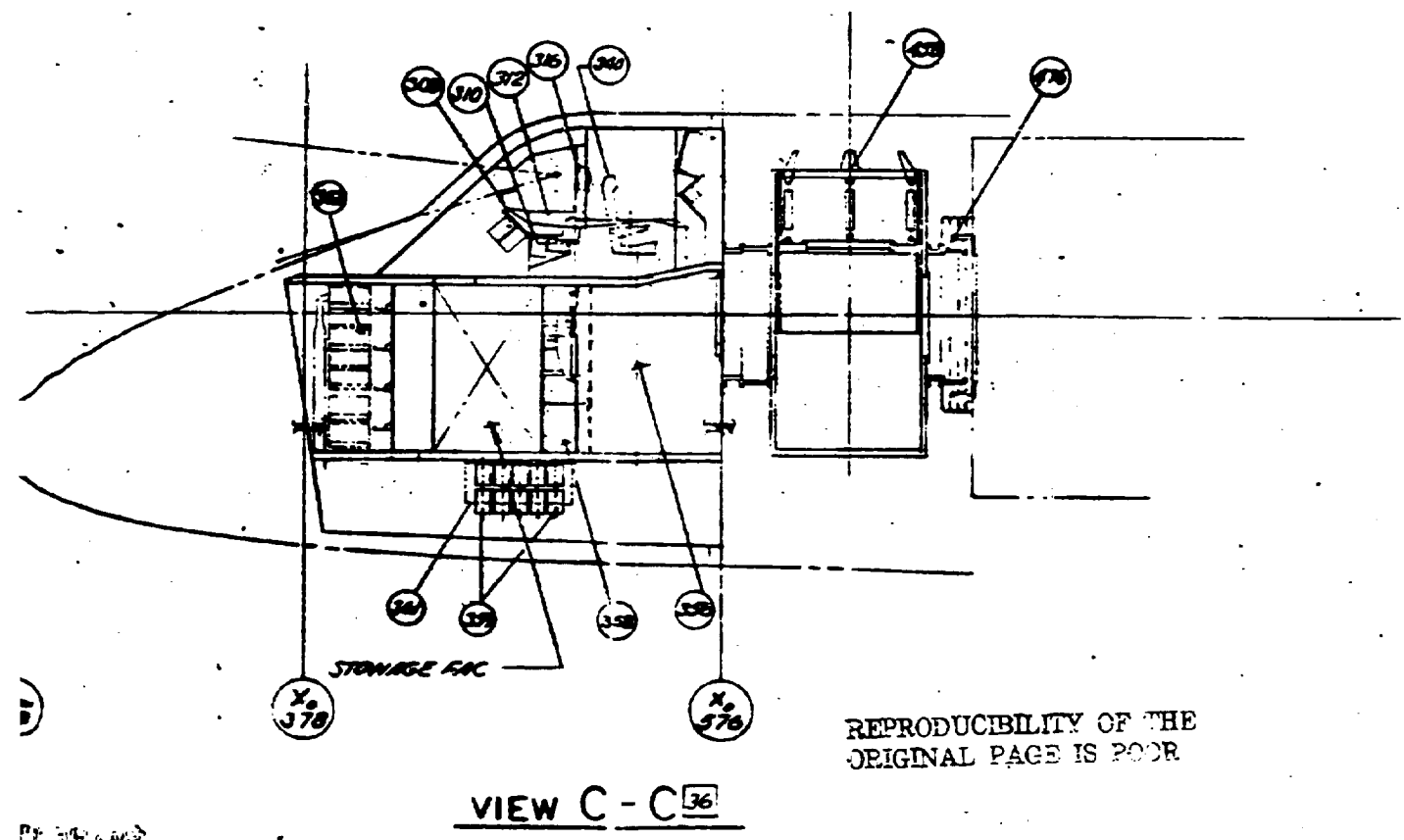
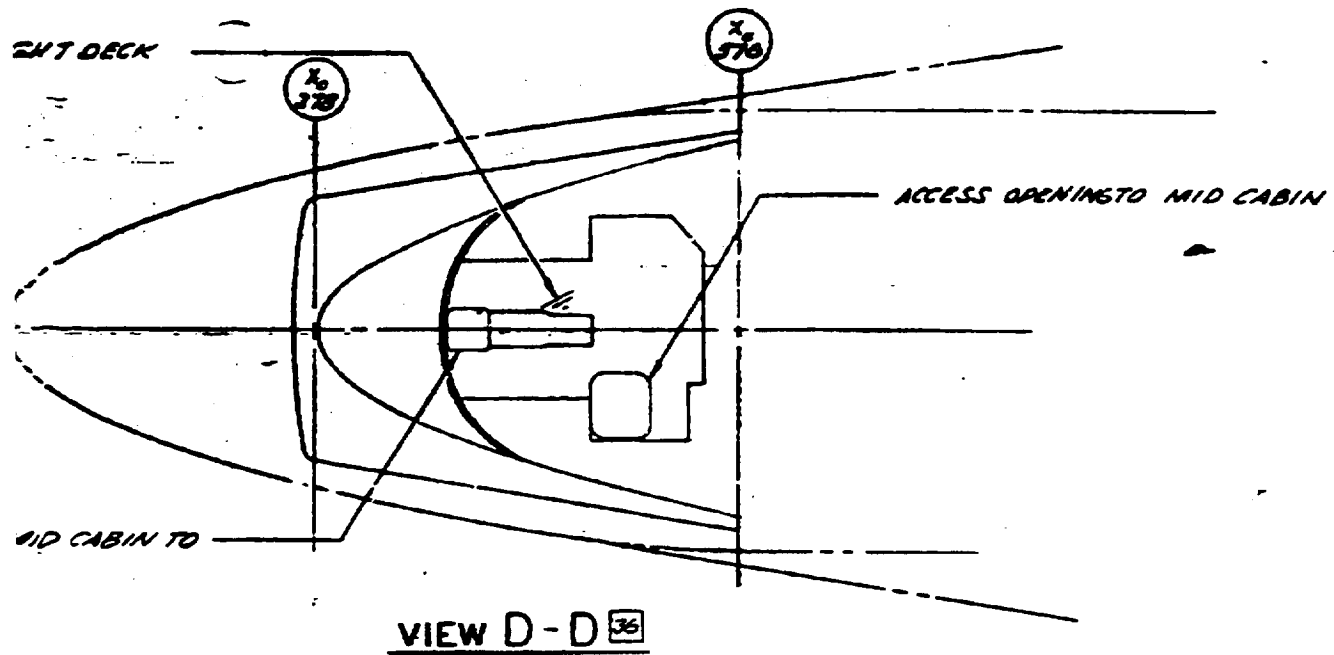

REPRODUCIBILITY OF THE ORIGINAL PAGE IS POOR

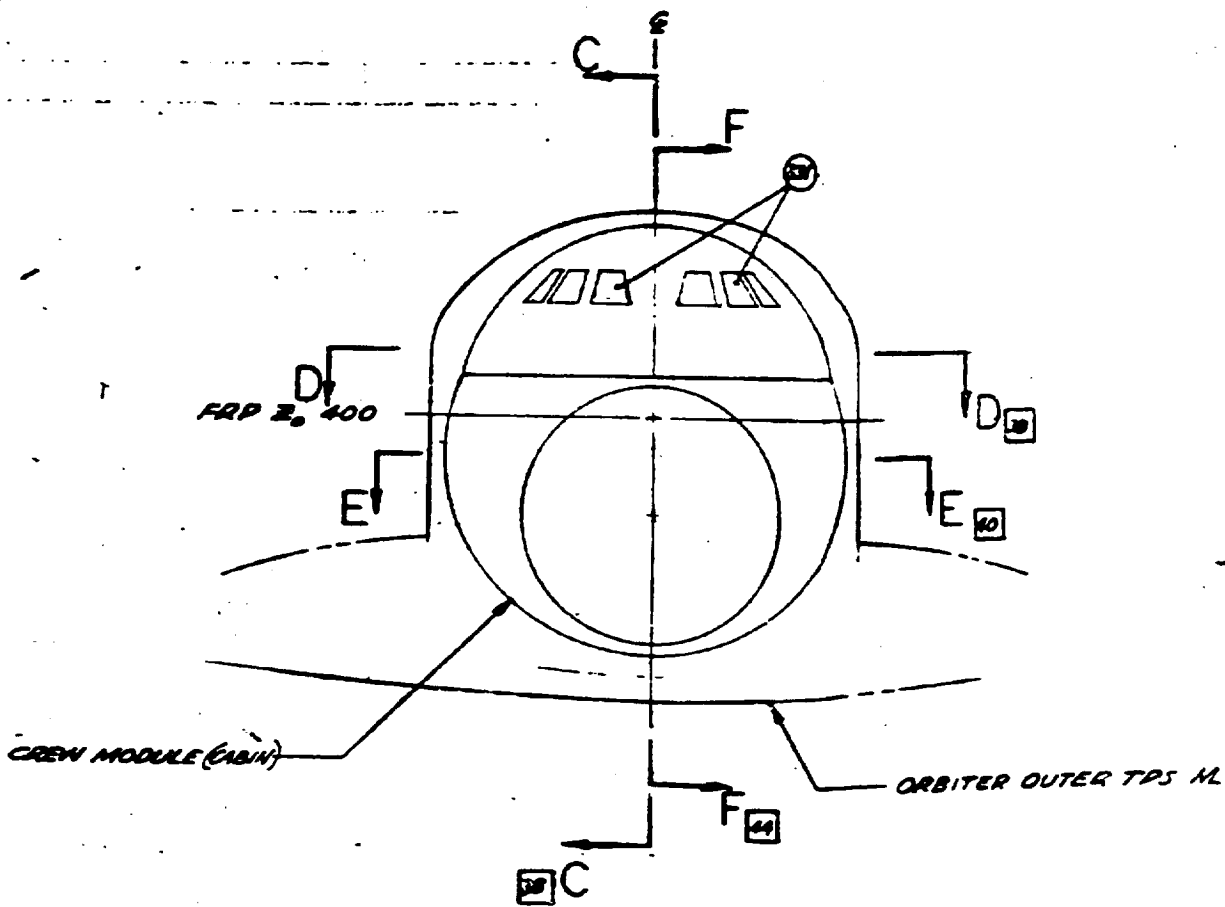

VIEW CREW MODULE LOOKING AFT

REPRODUCIBILITY OF THE ORIGINAL PAGE IS POOR

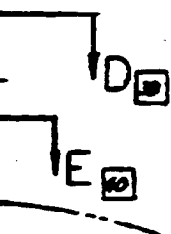

- ORBITER OUTER TPS M

NG AFT

EXAMINED BY: [illegible]

8

Figure 1. 1. 3. Space Shuttle System .

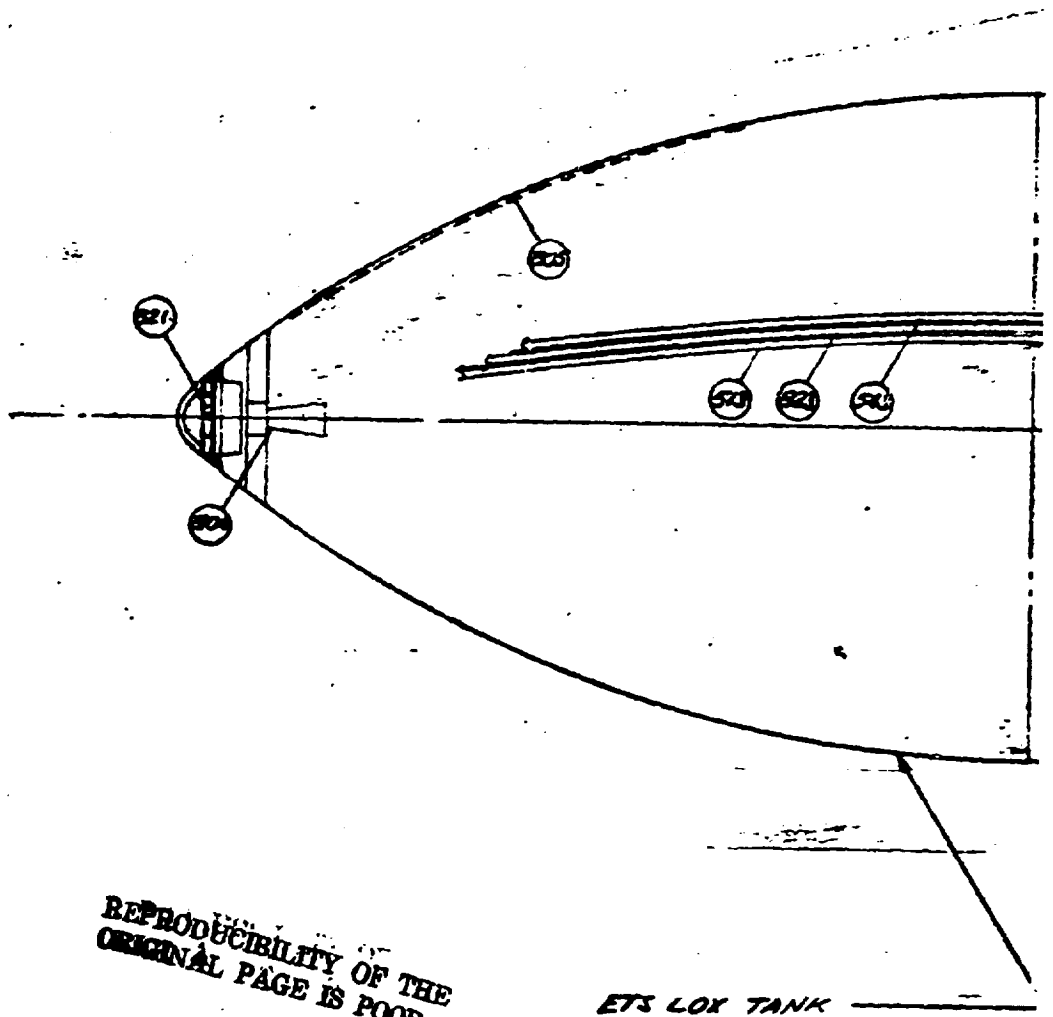

REPRODUCIBILITY OF THE ORIGINAL PAGE IS POOR

ETS LOX TANK

FOLDOUT FRAME

VL72-000091 5H2

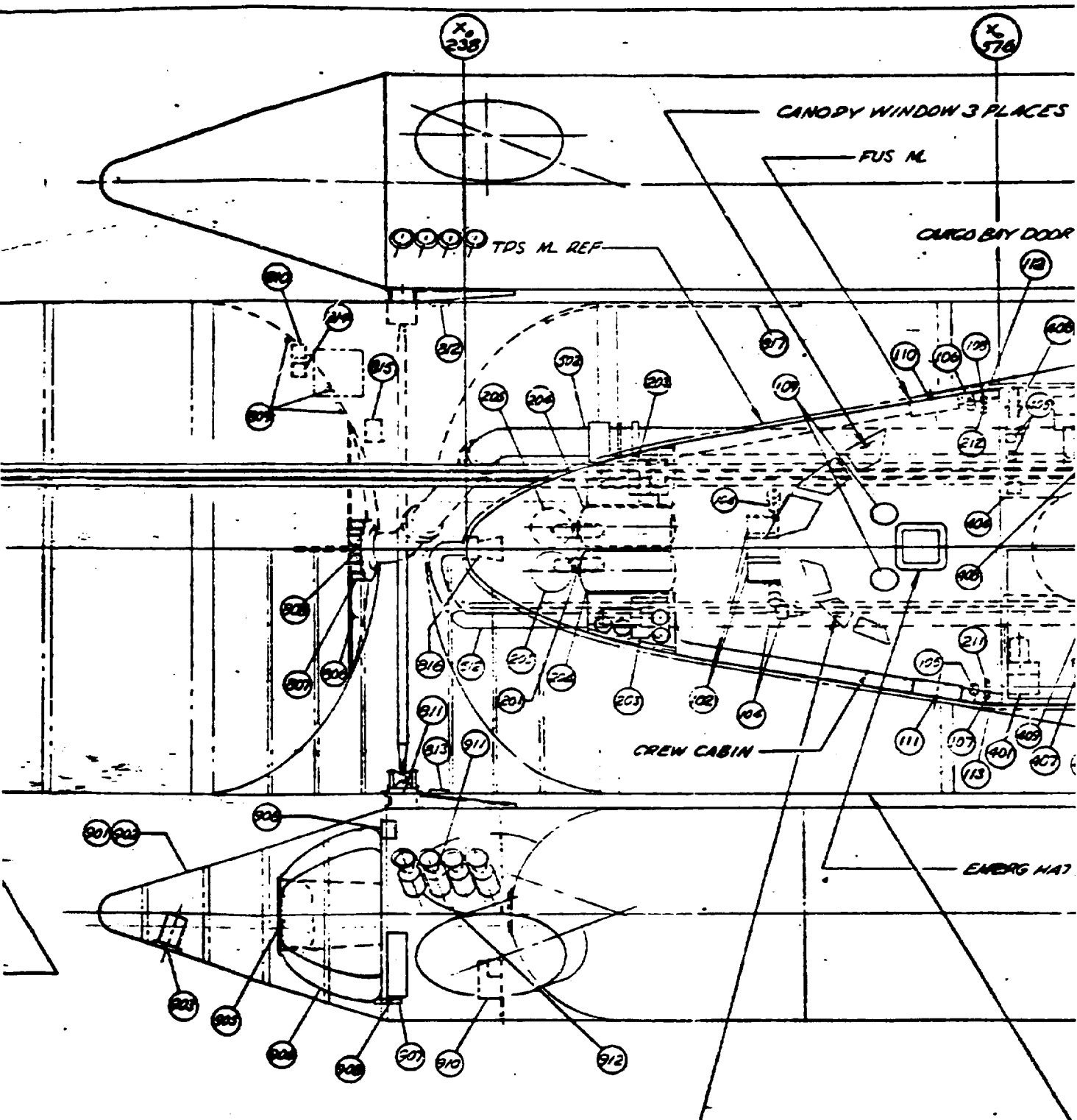

DOUT FRAME

CREW MODULE (CABIN) 3 PLACES LHSIDE
3 PLACES RH OPPOS

ETS LH₂ TANK

REPRODUCIBILITY OF THE
ORIGINAL PAGE IS POOR

2

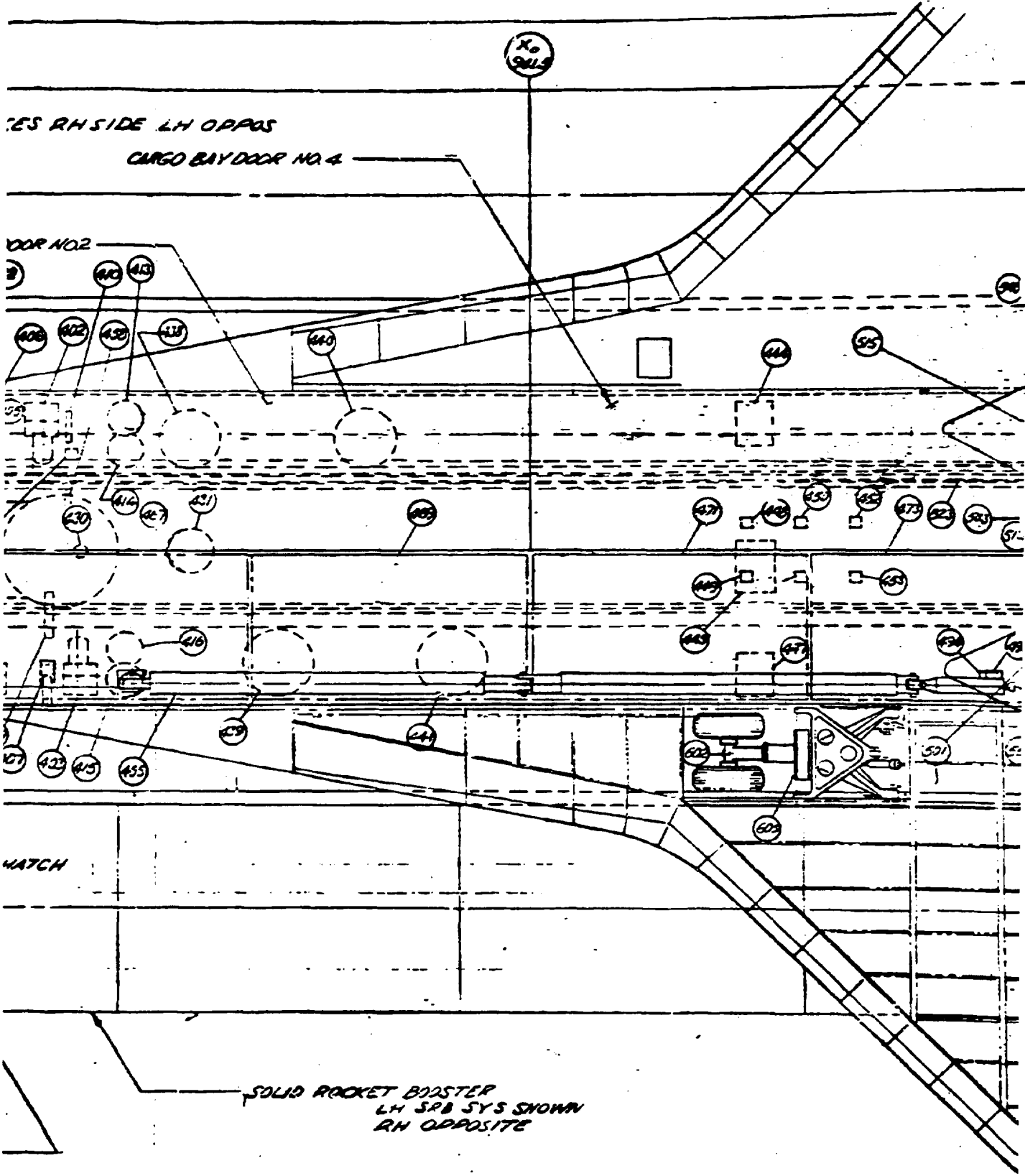

FT FRAME

3

31 32 33 34 35 36 37 38 39 40

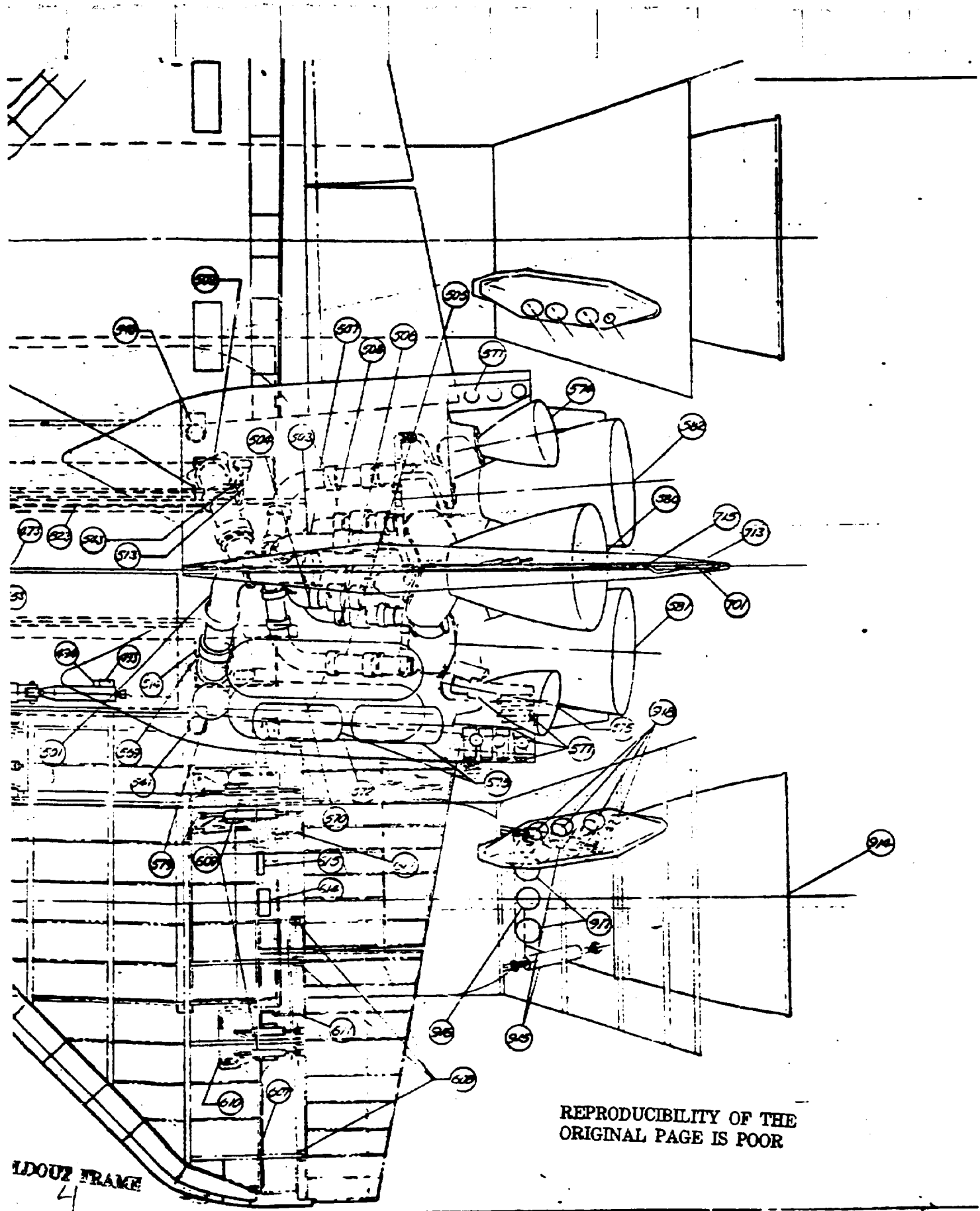

REPRODUCIBILITY OF THE ORIGINAL PAGE IS POOR

LDUOZ FRAME
4

REPRODUCIBILITY OF THE
ORIGINAL PAGE IS POOR

OUT FRAME

28

4672-000091 SH2

CM7

27

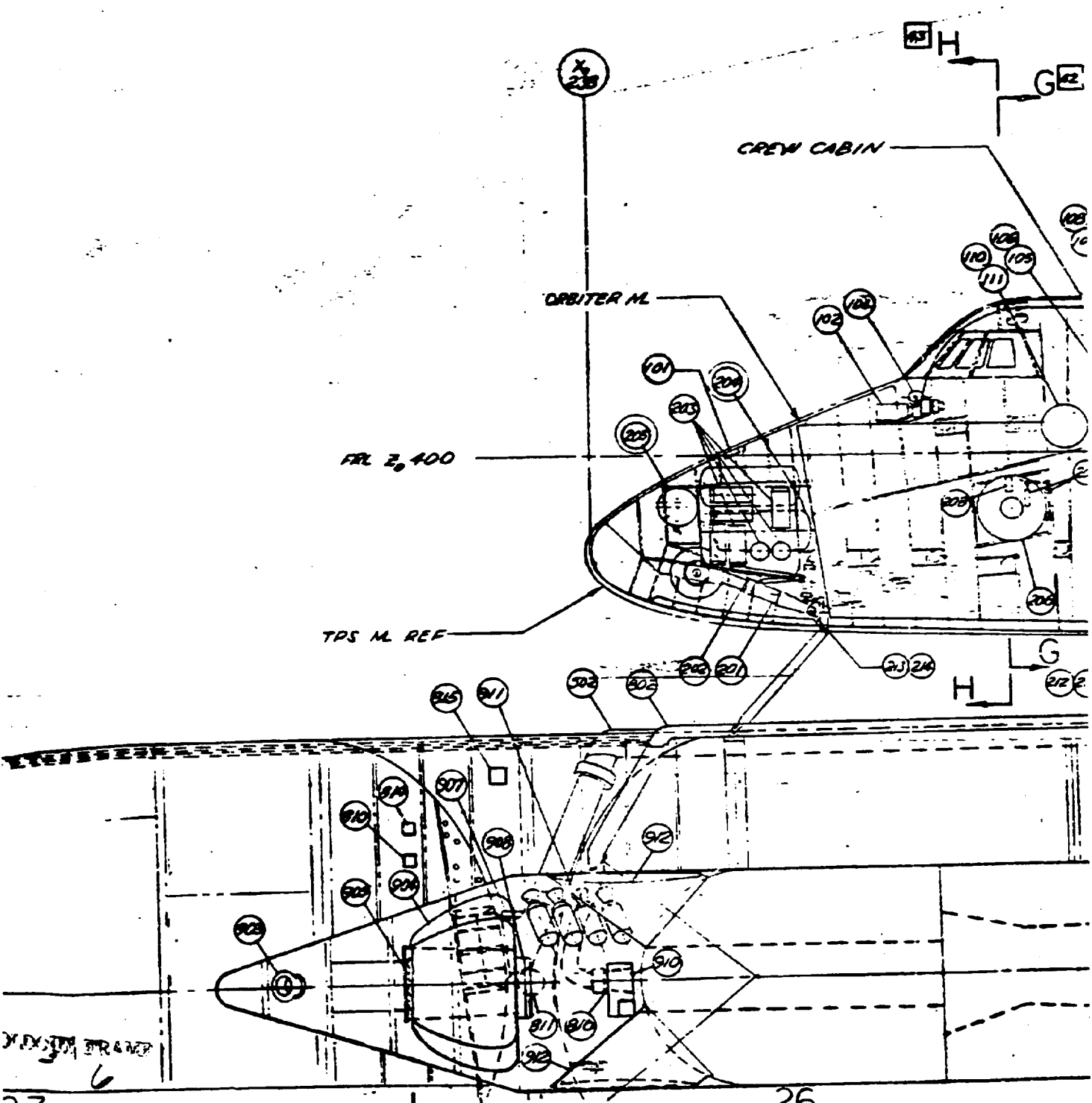

X-27
 6

REPRODUCIBILITY OF THE ORIGINAL PAGE IS POOR

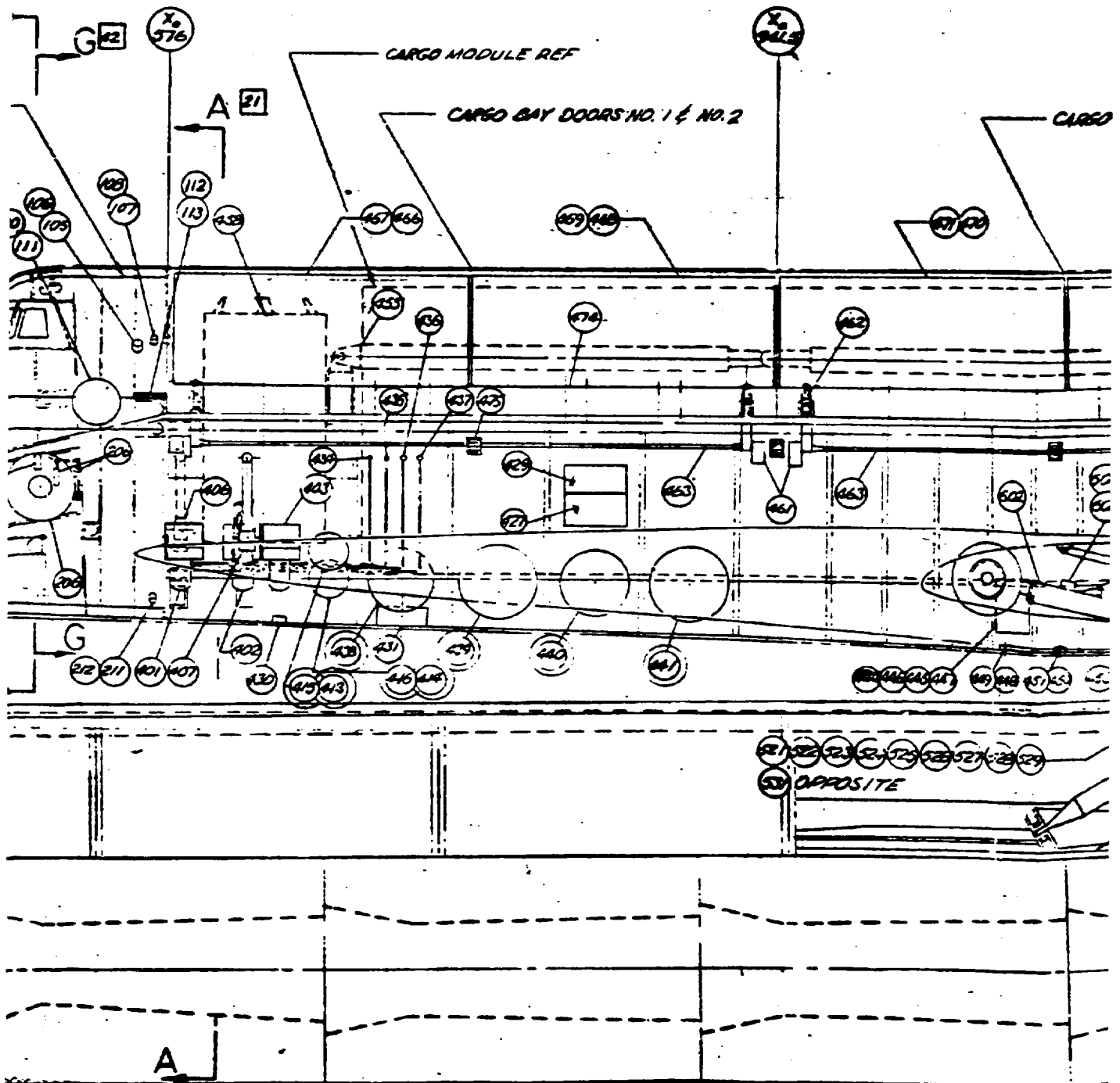

25 VL 72-000091 SH 2

407

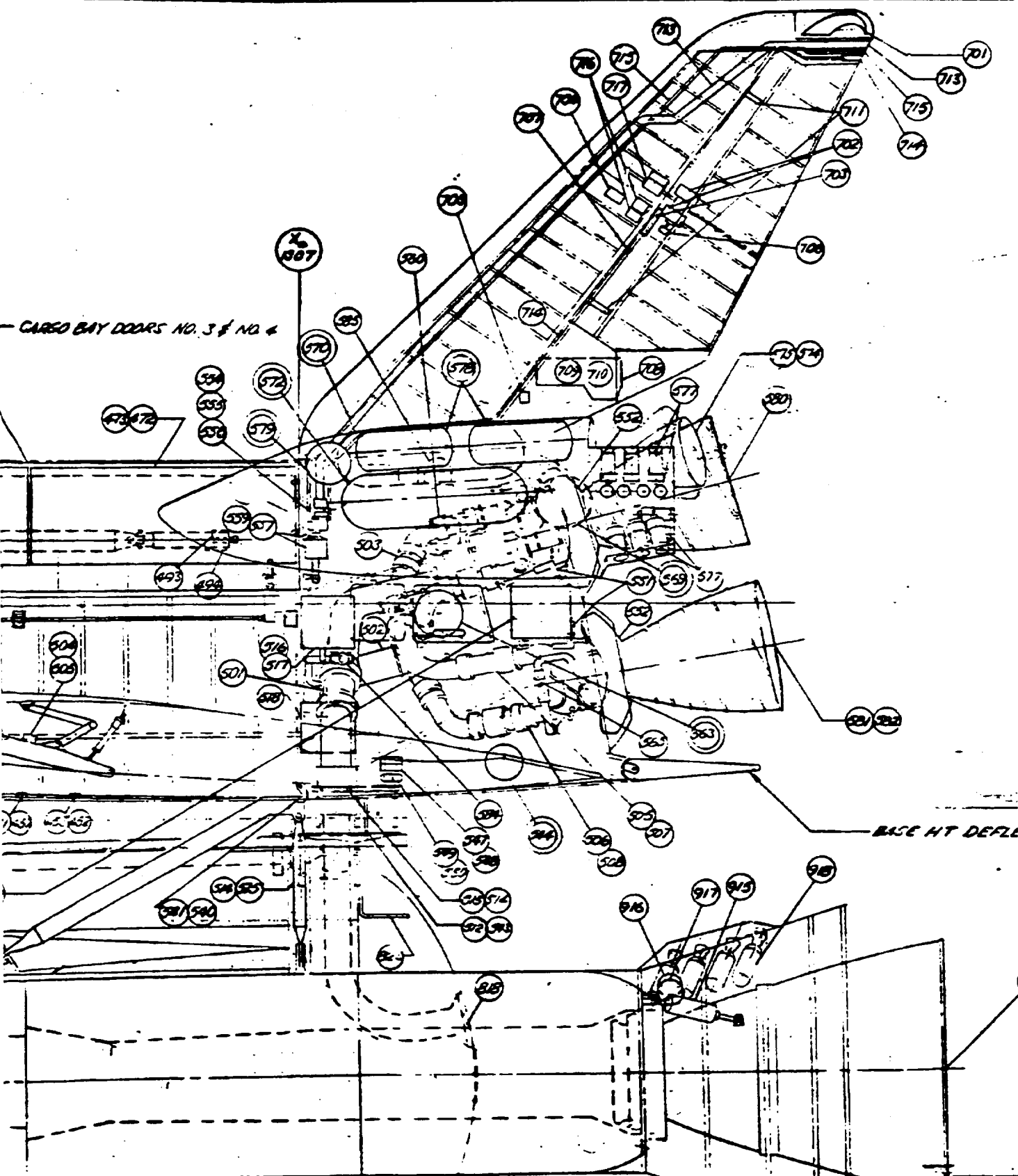

- CARGO BAY DOORS NO. 3 & NO. 4

BASE HT DEFL

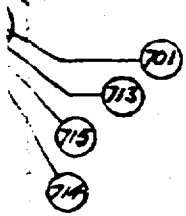

FDP 2

VEL MANIFOLD —

ORBITER OUTER TPS M. AT X, 576

ORBITER OUTER TPS M. AT X, 570 —

CARGO BAY LINER —

22

BASE HT DEFLECTOR

SRB REF

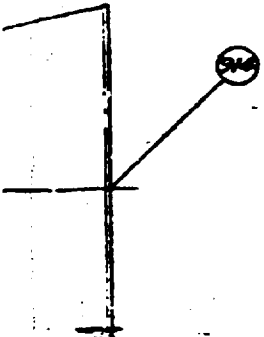
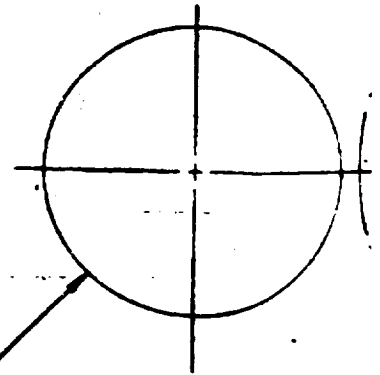

VL72-000091 SH 2

9 23

22

2 (m) 7

REPRODUCTION OF THE ORIGINAL PAGE IS POOR

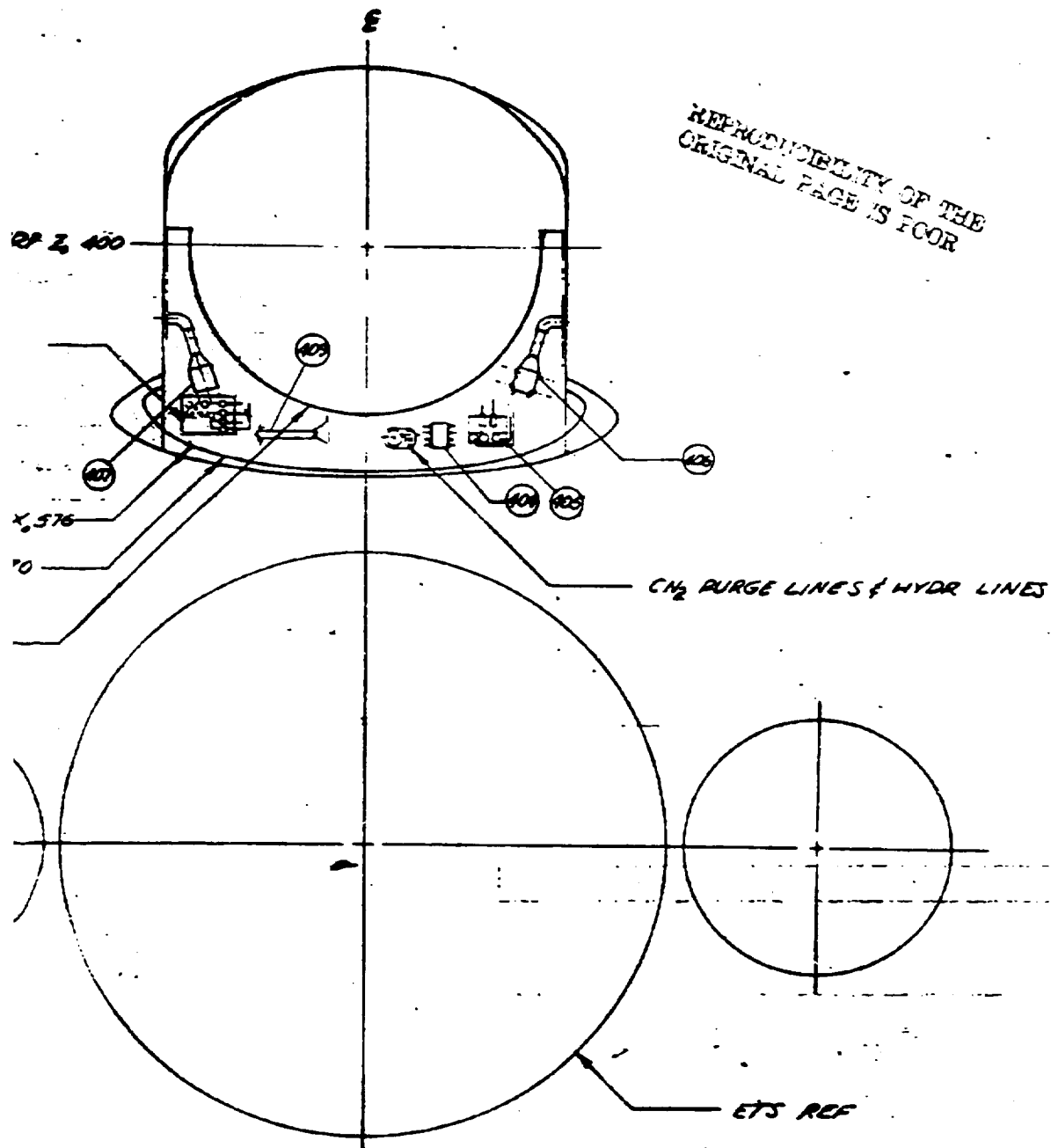

VIEW A - A 23

FRAME

10

21

20

REPRODUCTION OF THE ORIGINAL DRAWING IS FOR

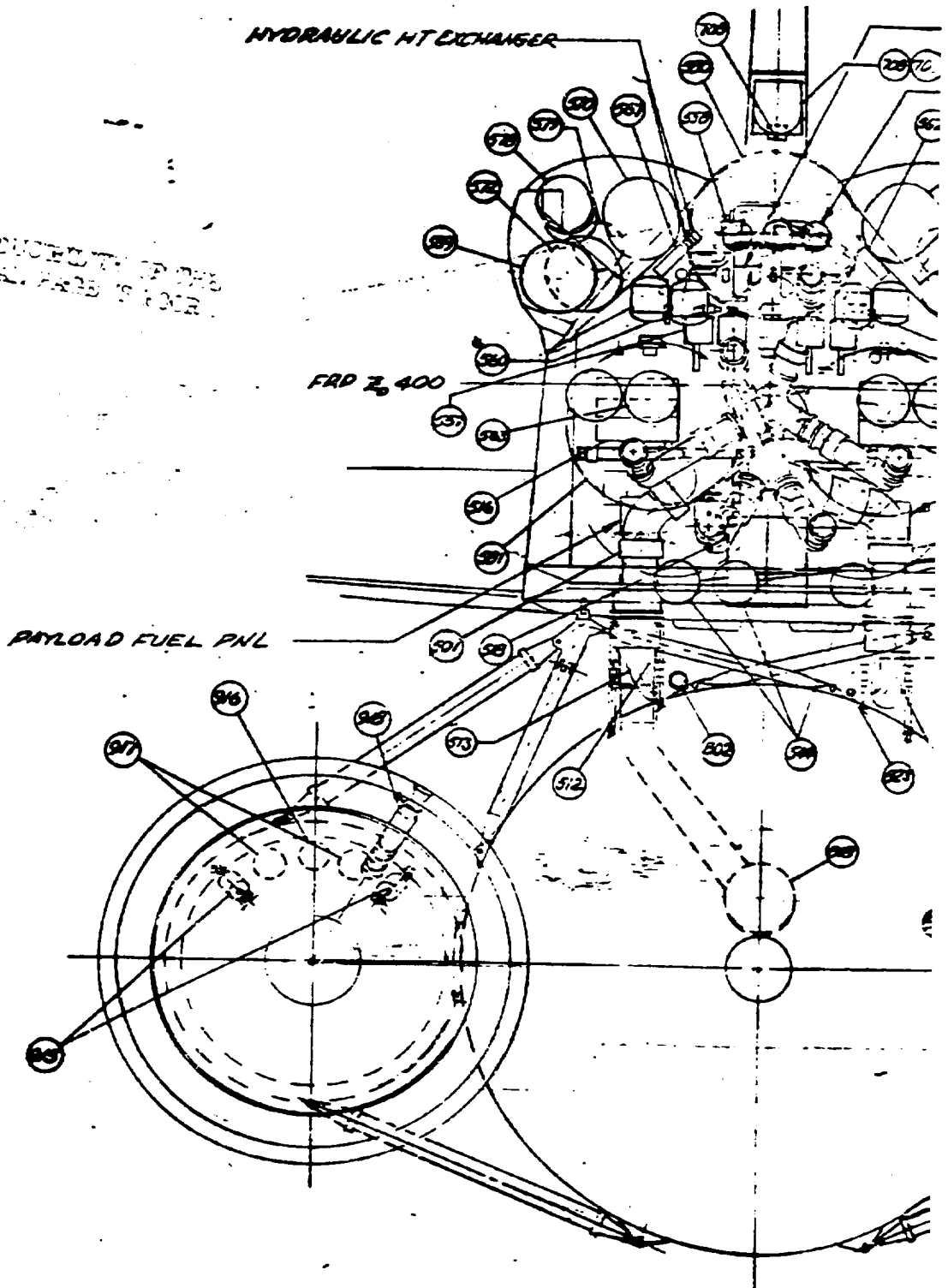

OLDOUT FRAME

VIEW LOOKING FWD TO BLKH

//

20

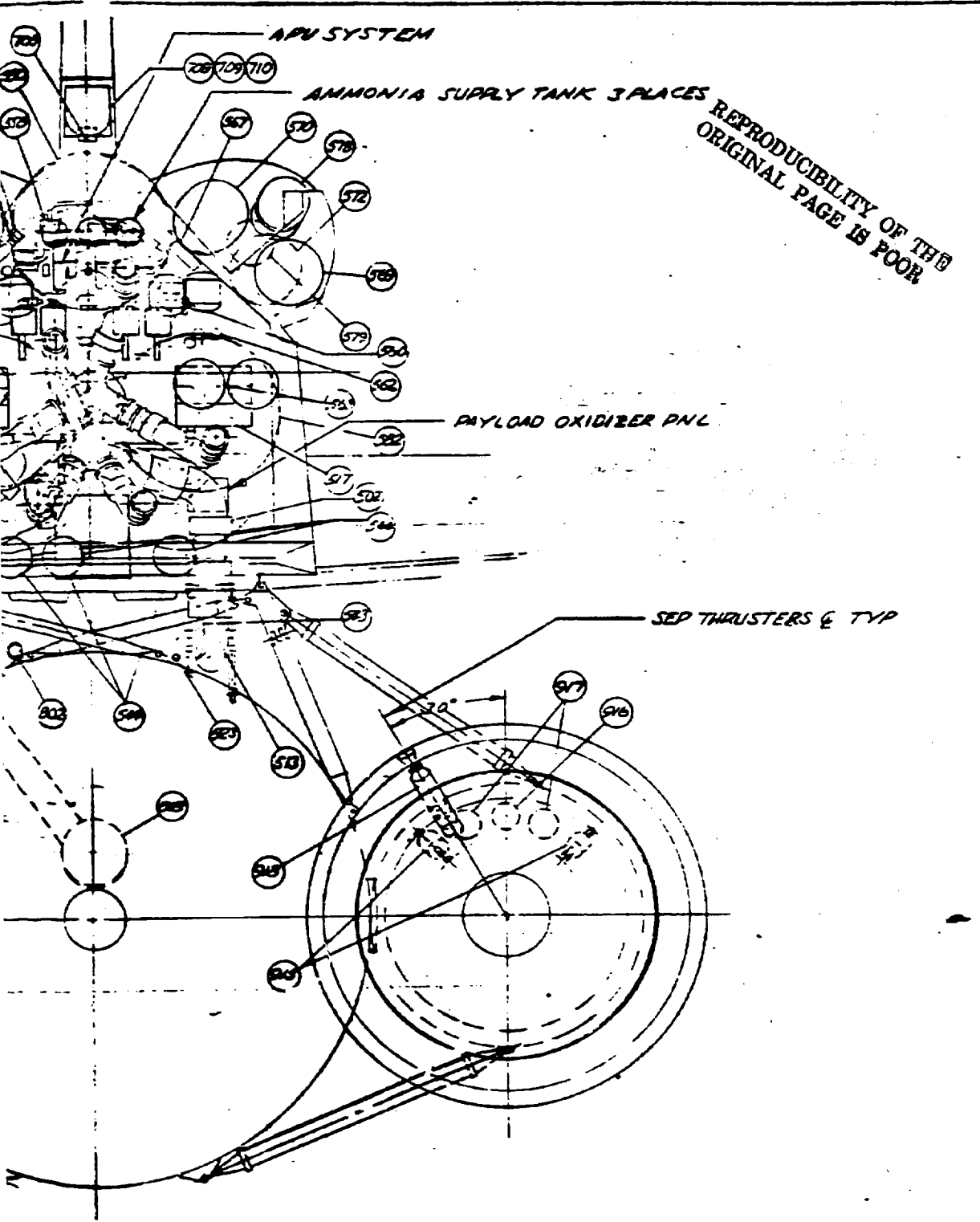

REPRODUCIBILITY OF THE ORIGINAL PAGE IS POOR

VIEWING FWD TO BLKHD X 130°

FOLDOFF FRAME

Figure 1.1.4. Space Shuttle System

12

REPRODUCIBILITY OF THE ORIGINAL PAGE IS POOR

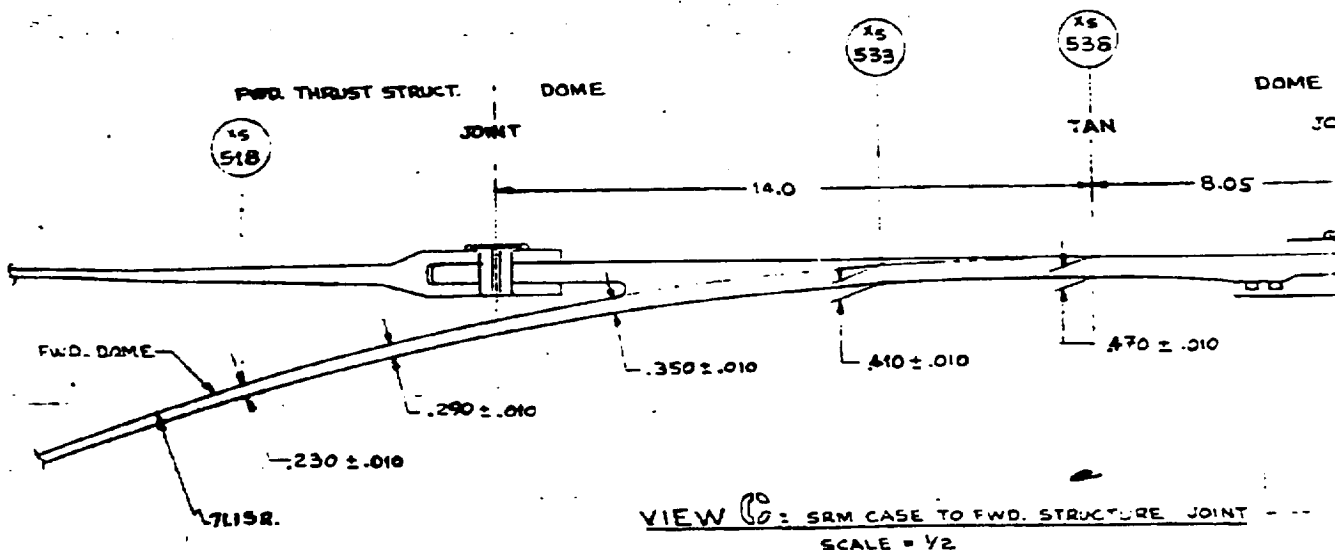

T FRAME

THRUST ATTACH FTG.
 MAIN CHUTE & DROGUE
 CHUTE CABLE RISER
 ATTACH FITTING

ET (TANK) M.
 UMBILICAL
 & CHUTE GUSSET

FLOATATION BAG
 MAIN CHUTE

SEPARATION
 MOTORS 15.7 SPM.

8.0 DIA. MORTAR
 (PILOT DROGUE)

9.0 DIA. MORTAR
 (SHROUD PILOT & CHUTE RISER)

ACCESS DOOR, 30 DIA.
 FLIGHT RECORDER, RECOVERABLE
 (24.5 X 24.0)

END VIEW

LOOKING AFT. W/O NOSE CONE

ET 810
 DOME ET, LO₂

DROGUE PARACHUTE RISER
 • ATTACHMENT
 • DISCONNECT, 2 REDUNDANT

MAIN PARACHUTE RISER
 • ATTACHMENT
 • DISCONNECT, 2 REDUNDANT

TOW LINE ATTACHMENT
 (SWIMMER ATTACK)

AVIONICS
 • ANTENNA (2)
 • MALFUNCTION DETECT. SYS. (2)
 • FLASHING LITES (2)
 • BEACONS (2)
 • SEQUENCERS (2)
 • BATTERIES (2)

NOSE CONE

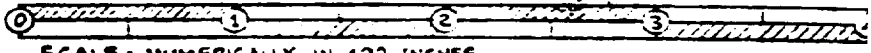

SCALE: NUMERICALLY IN 100 INCHES

DOME CASE
 JOINT

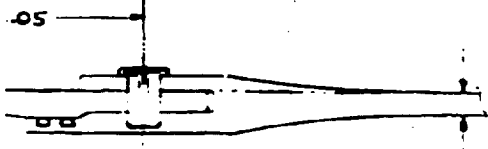

.470
 SRM CASE
 (TYP.)

MAIN PARACHUTE INSTL.
 • PARACHUTE PACK, 6 CHUTES
 80 FT. DIA., RIBBON TYPE
 • REEFING CUTTERS:
 2 @ 1st STAGE, 2 @ 2nd STAGE
 • FLOATATION BAG
 • BATTERY, FLASHLIGHT (W/SWS)
 • BASED ON Δ WT. 160N, 80FPS

FLIGHT RECORDER
 FLOATATION BAG
 (SWIMMER HOLDS)
 SEPARATION RELEASE,
 (NOSE CONE)
 EJECTION BAG
 (DROGUE CHUTE)

RECOVERY HOLD
 (NOSE CONE RISER ATTACH)
 RECOVERY CONTINGENCY

DROGUE CHUTE INSTL.
 • CHUTE 62 FT. DIA. RIBBON TYPE
 • REEFING CUTTERS: 2 @ 1st STAGE,
 2 @ 2nd STAGE
 • RISER DISCONNECT, 2 REDUNDANT
 • EJECTION BAG, BATTERY
 • FLASHLIGHT, (W/SWS)

BOOSTER RECOVERY INSTL.
 • SEQUENCER
 • BATTERY
 • FLASHLIGHT, (W/SWS)

16
 200

16
 381

FWD.
 & NOSE

1 DOOR FRAME

2

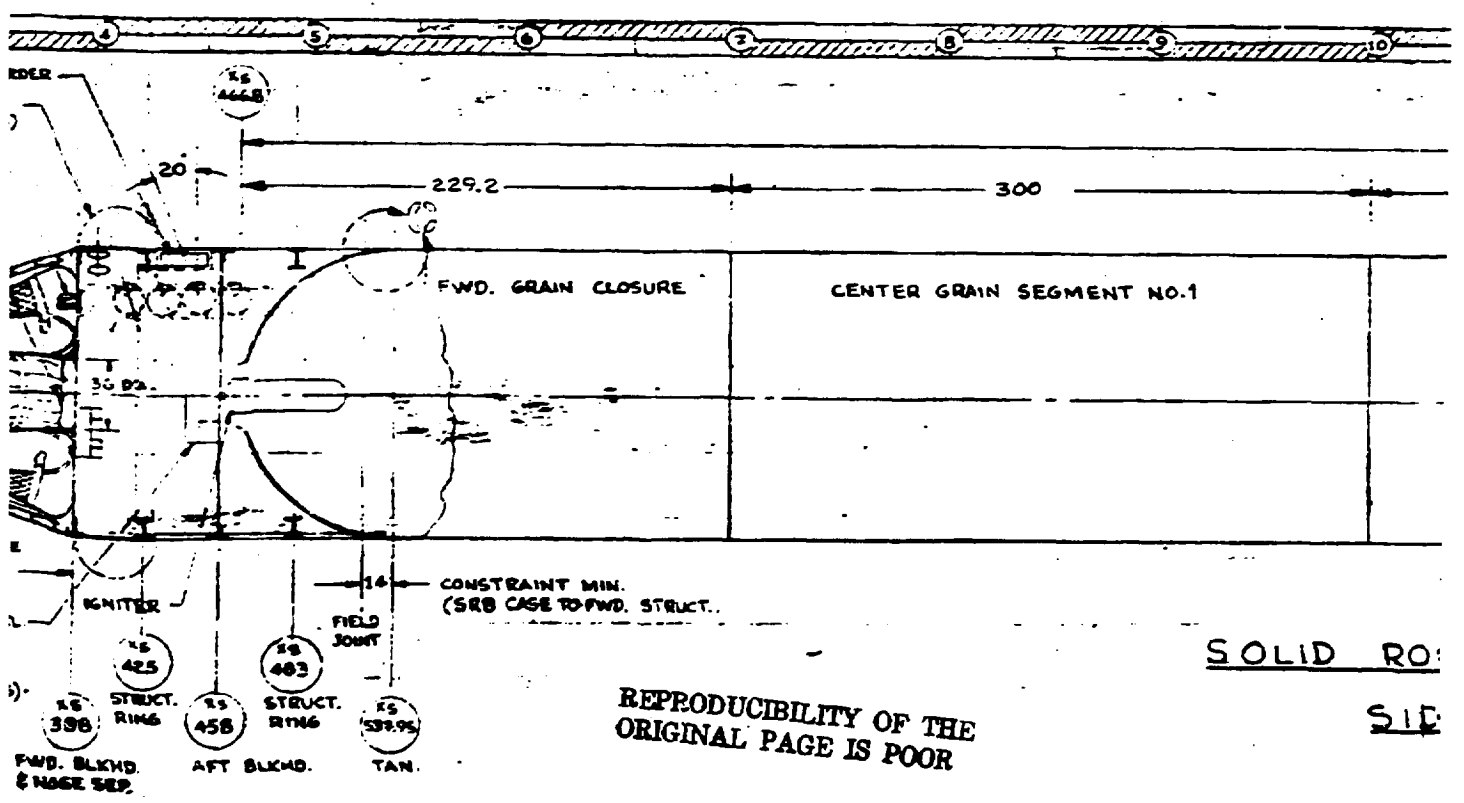
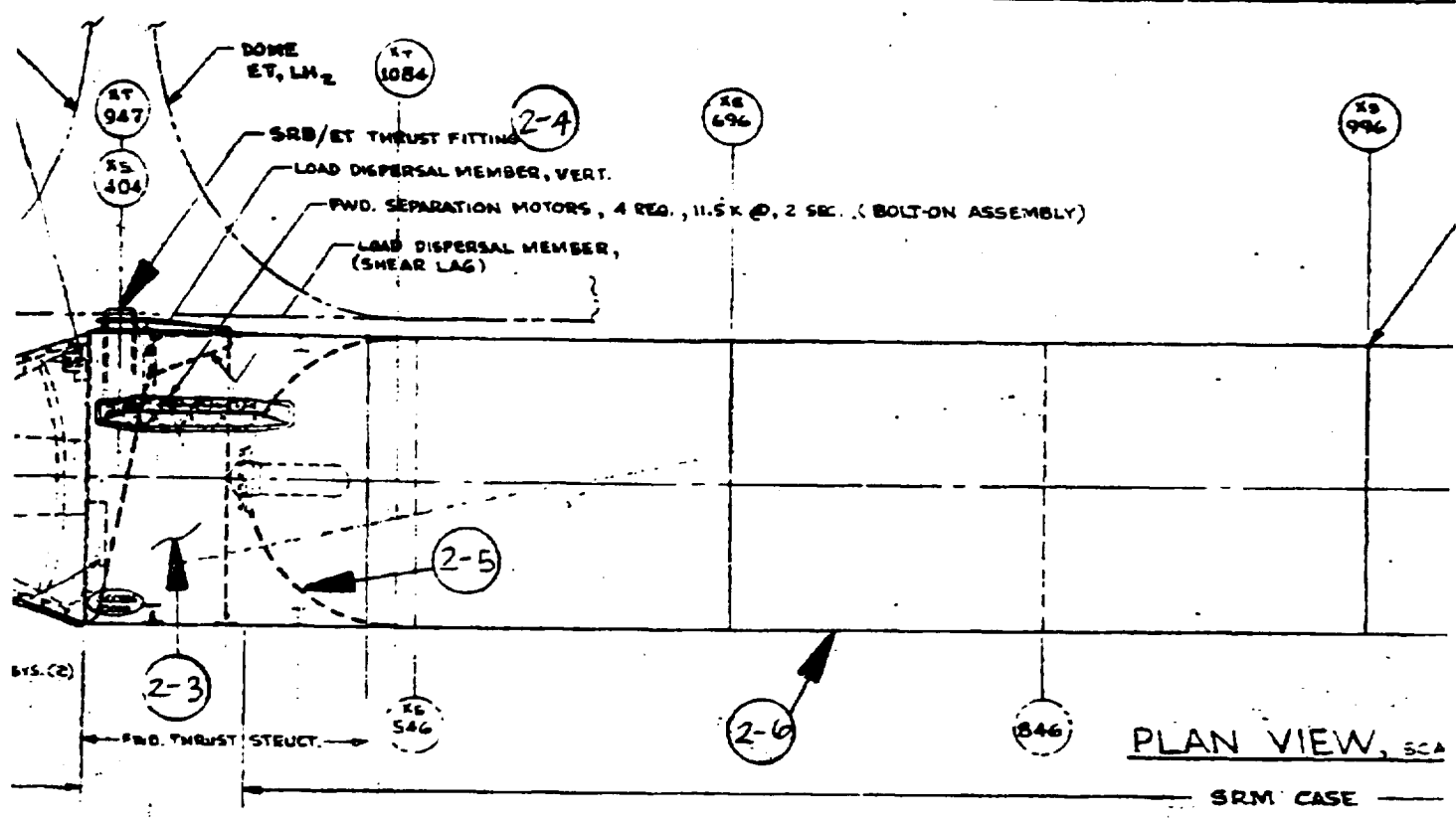

REPRODUCIBILITY OF THE ORIGINAL PAGE IS POOR

BOUT FRAME

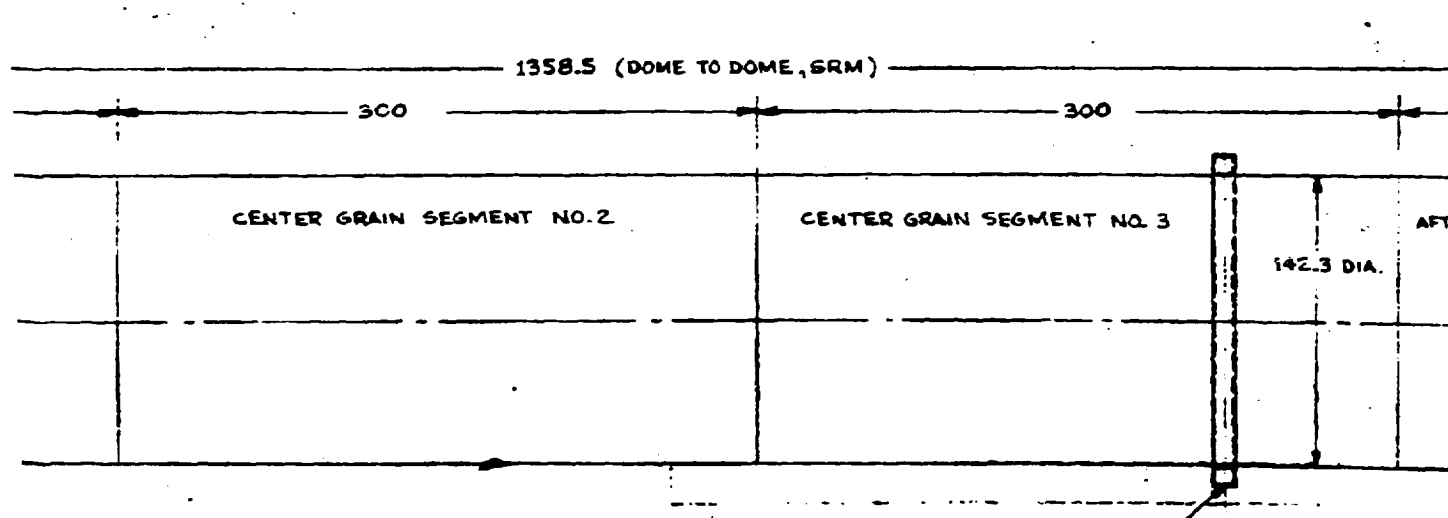
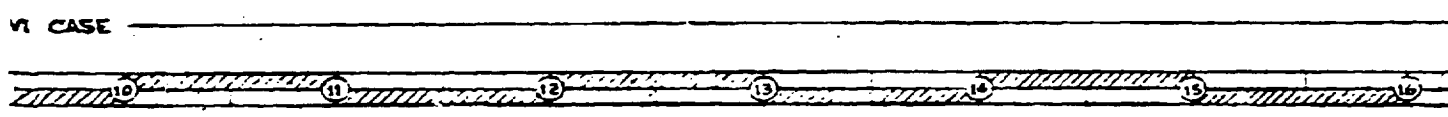
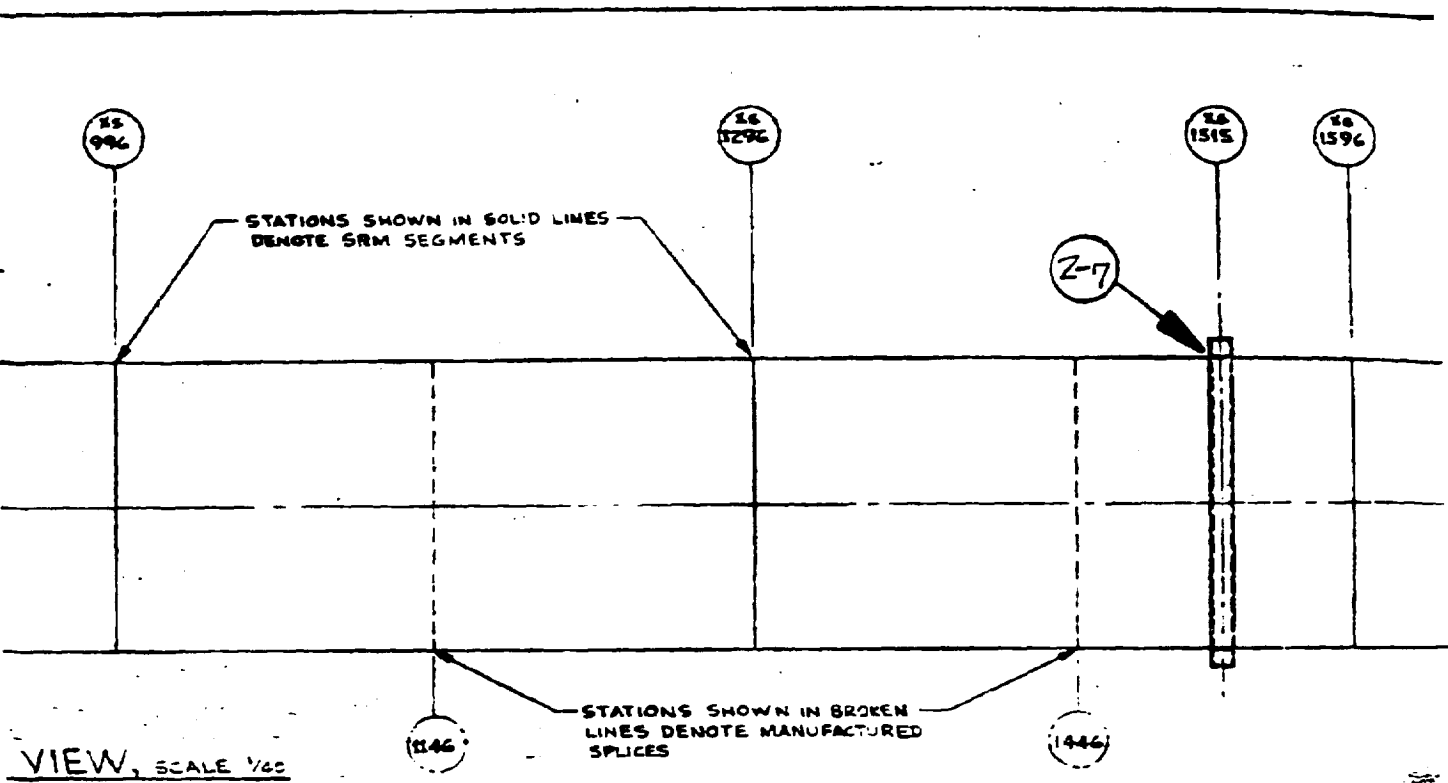

-ID ROCKET BOOSTER

SIDE VIEW, SCALE 1/40

REPRODUCIBILITY OF THE ORIGINAL PAGE IS POOR

18 (1515)

ABOUT WRAMP

41

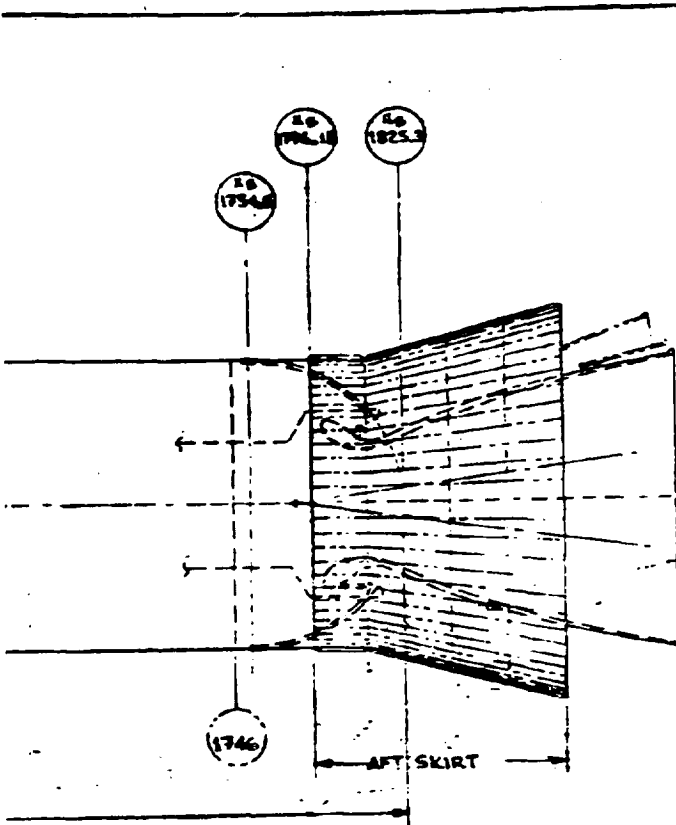

AFT SEPARATION
 MOTOR INSTL
 (SEE SECT. A-A)

LAUNCH SUPPORT
 4 PLACES, SEE
 LEGEND BELOW

TANK SIDE - ET

Y
 YAW AXIS

ORBITER
 SIDE

30° (TYP., 4 PLCS)

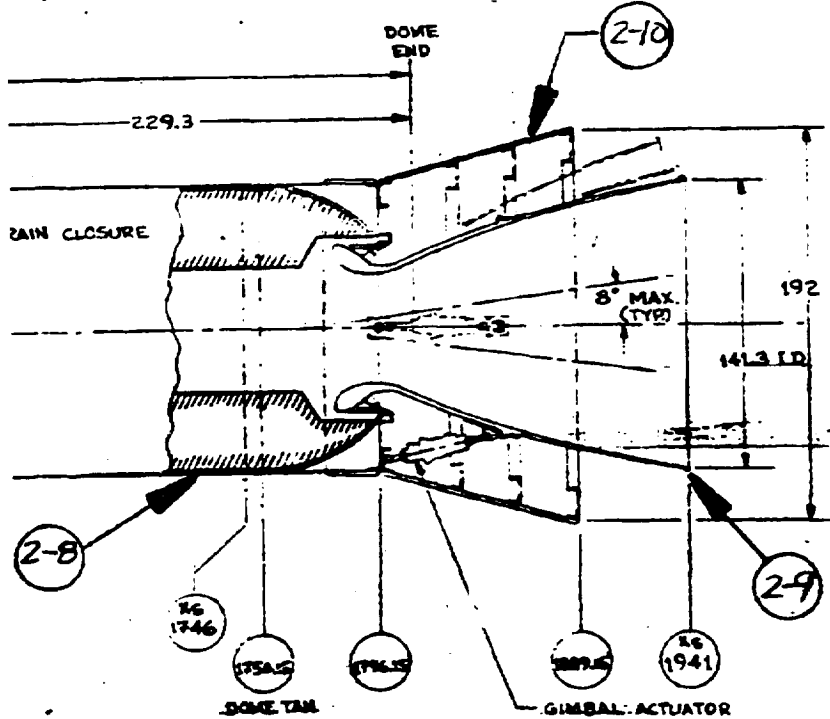
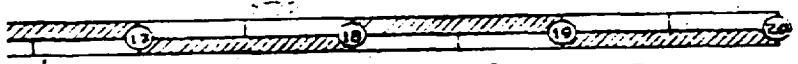
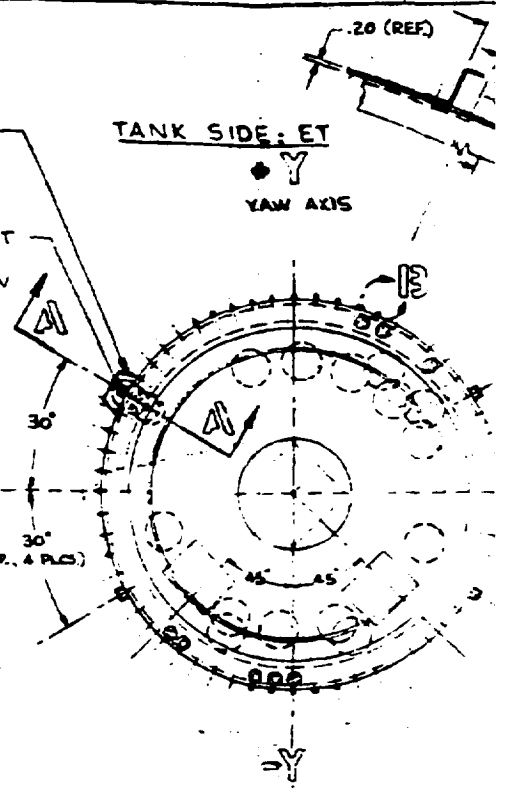

PRIMARY TVC SYS.

- ACTUATOR ENVELOPE
- N₂ PRESS FILL
- N₂ C/O
- HYD. FLUID FILL & C/O
- HYD. FLUID OVERBOARD DUMP

ACTUATOR (TYP)

PITCH AXIS

AFT VIEW
 SCALE 1/40

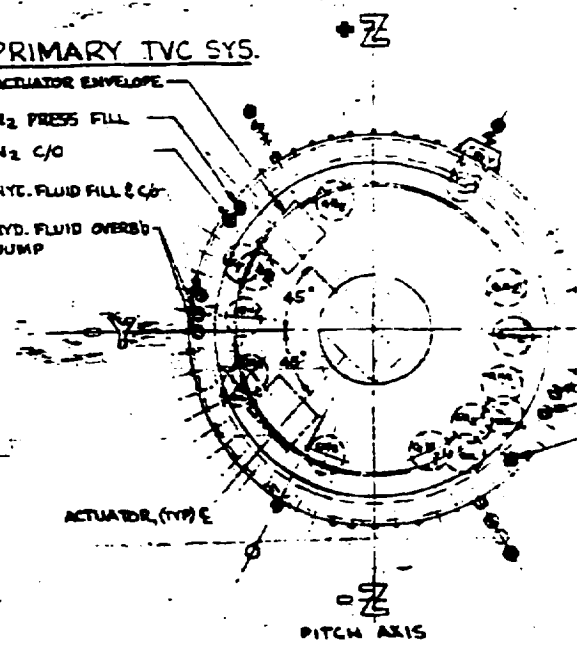

T FRONT

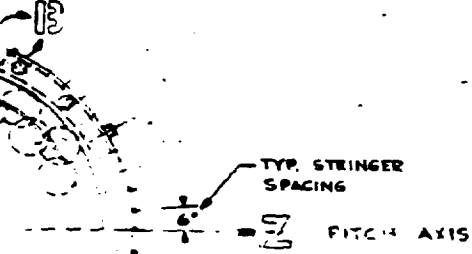
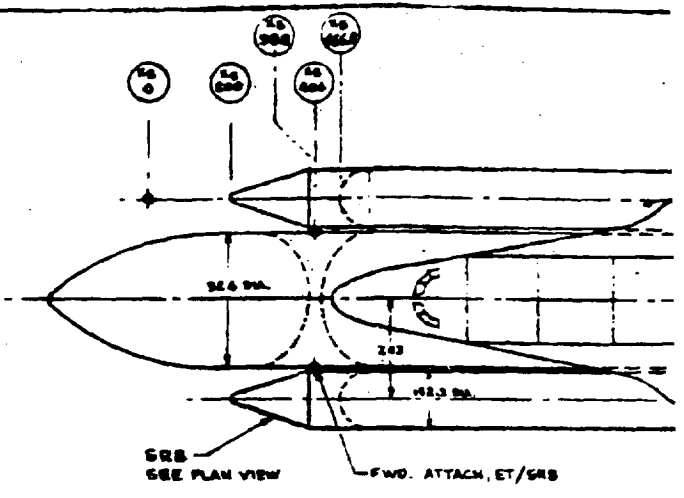
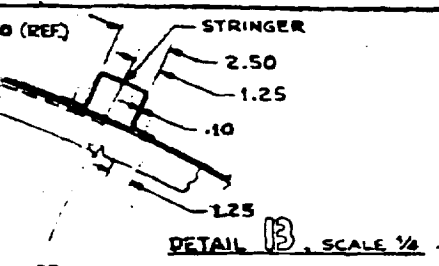

REPRODUCIBILITY OF THE ORIGINAL PAGE IS POOR

BA

AFT SEPARATION MOTORS
4 REQ. - 11.5 K @ 2 SEC.
(BOLT-ON ASSEMBLY)

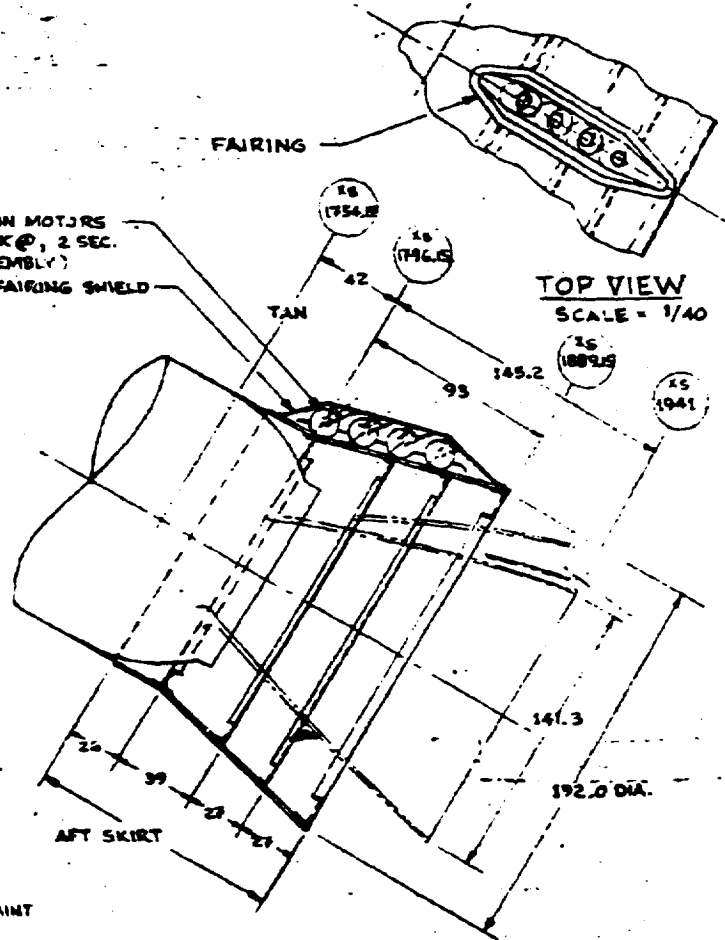

TOP VIEW
SCALE = 1/40

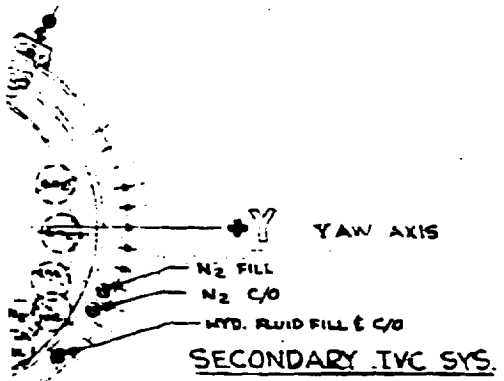

LEGEND

- GSE SUPPORT POINTS
- TYPE 1. GSE OVERTURN RESTRAINT
- TYPE 2. LEVELING JACKS
- TYPE 3. COMPRESSION SUPTS.
- TYPE 4. ALIGNMENT PADS

SECTION A-A SCALE = 1/40
AFT SRB SEPARATION MOTORS, 4 REQ.

Fig 1

BOUP FRAME

6

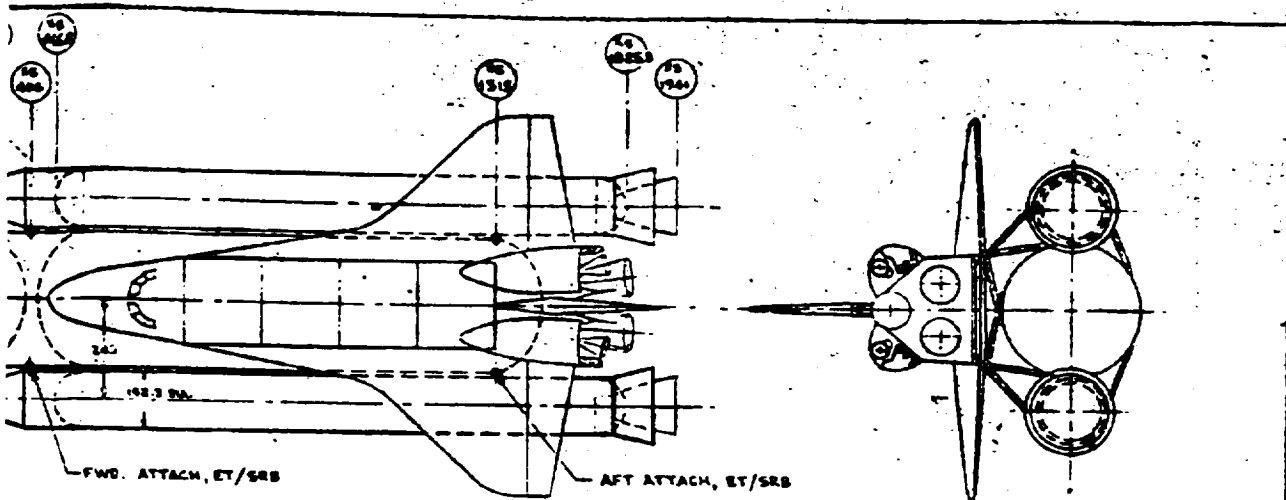

BASIC LAUNCH CONFIGURATION
SCALE = 1/200

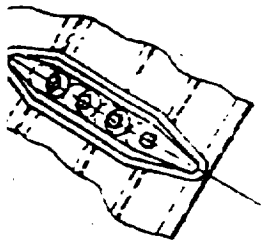

TOP VIEW
SCALE = 1/40

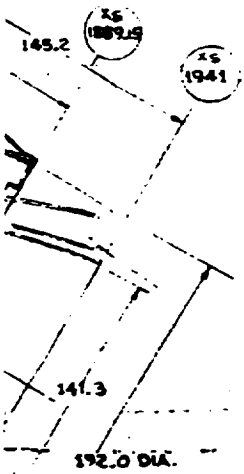

REPRODUCIBILITY OF THE
ORIGINAL PAGE IS POOR

BOLDOUT FRAME

E = 1/40
ORS, 4 REQ.

Figure 1. 2. 1. Solid Rocket Motor Assembly

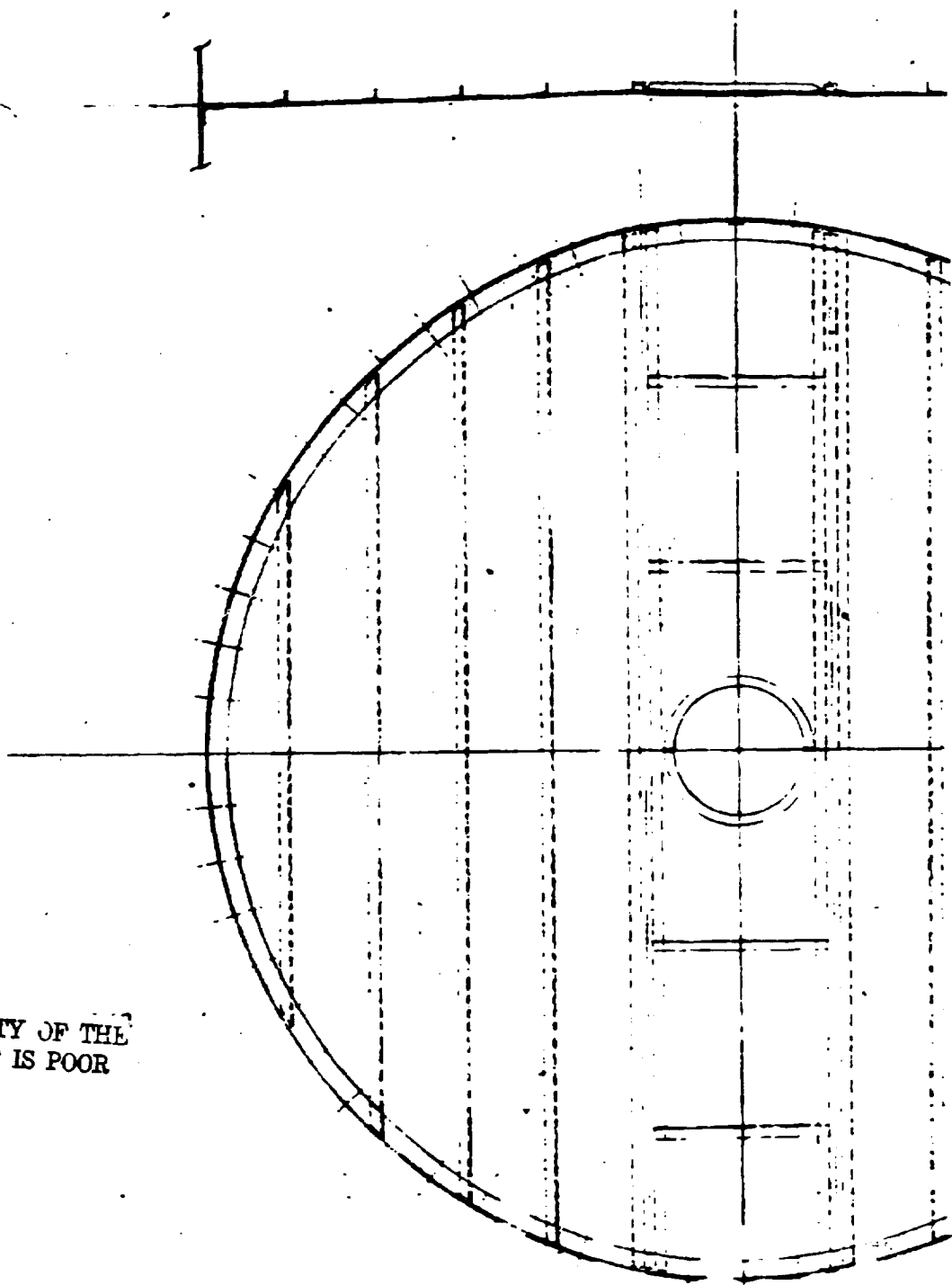

REPRODUCIBILITY OF THE
ORIGINAL PAGE IS POOR

SECTION B-B

RODDOUT FRAME

VL77-000045

REPRODUCIBILITY OF THE
ORIGINAL PAGE IS POOR

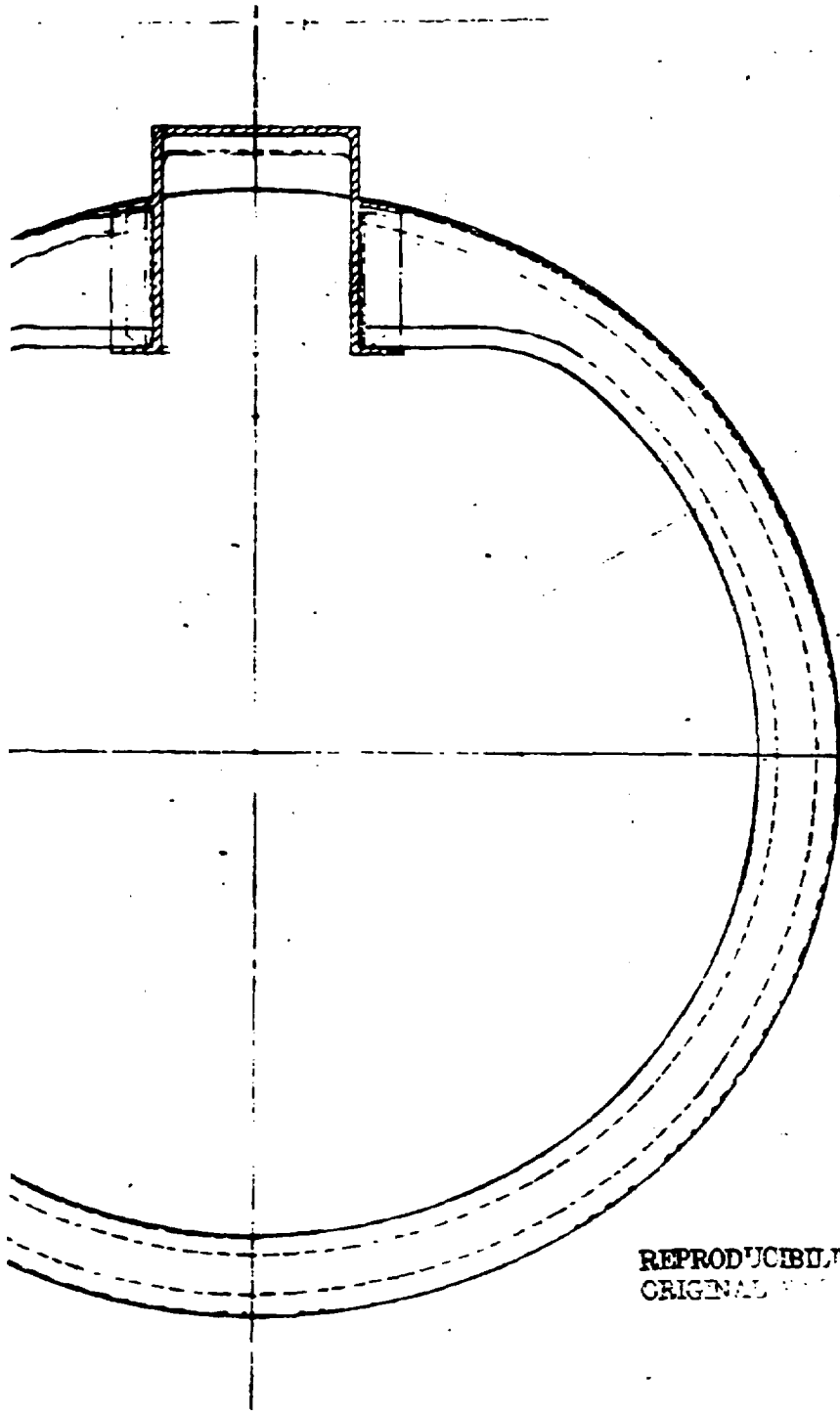

REPRODUCIBILITY OF THE ORIGINAL DESIGN

~~SECTION A-A~~

NO. 10077 FR. 10077

3

VL77-003045

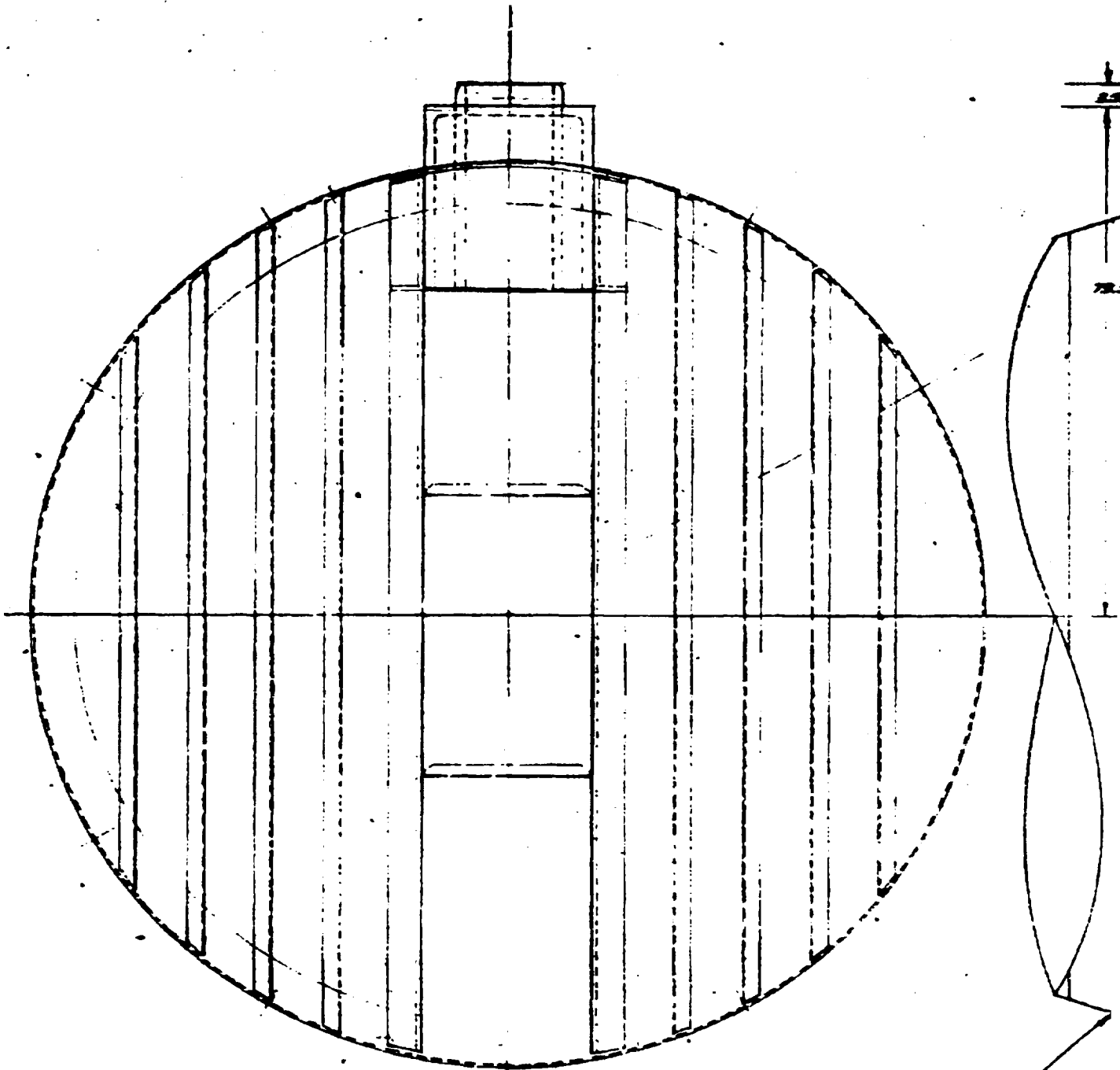

SECTION C-C

VL7-00021 A

F FRAME

4/

3024

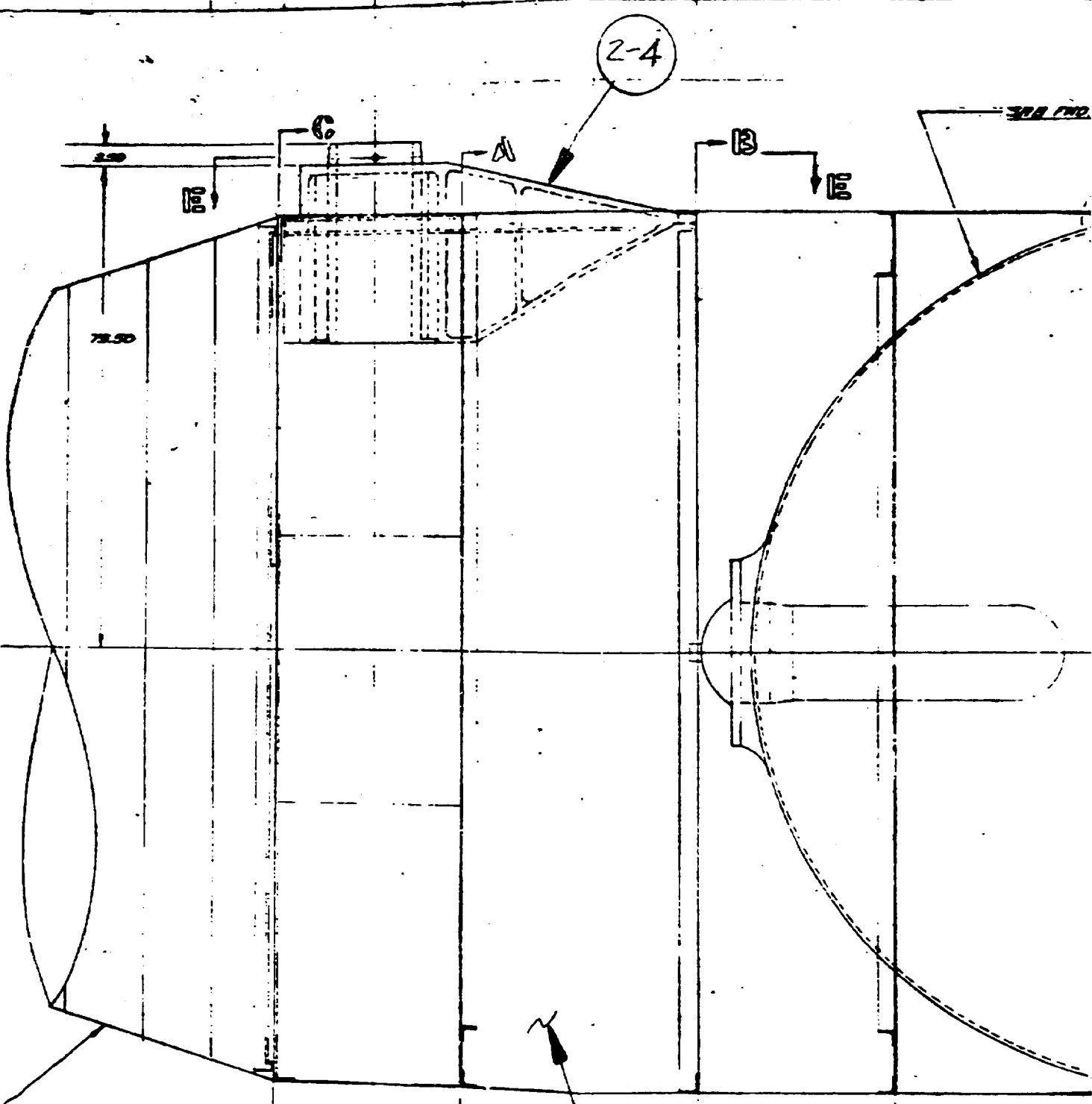

VL77-000021 NOSE STRUCTURE (REF)

NOSE FRAME

X-308

L-404

L-410

2-3

L-4100

L-0620

10

VL77-000045

5

2. EMP. DATE (YR)

2.5795

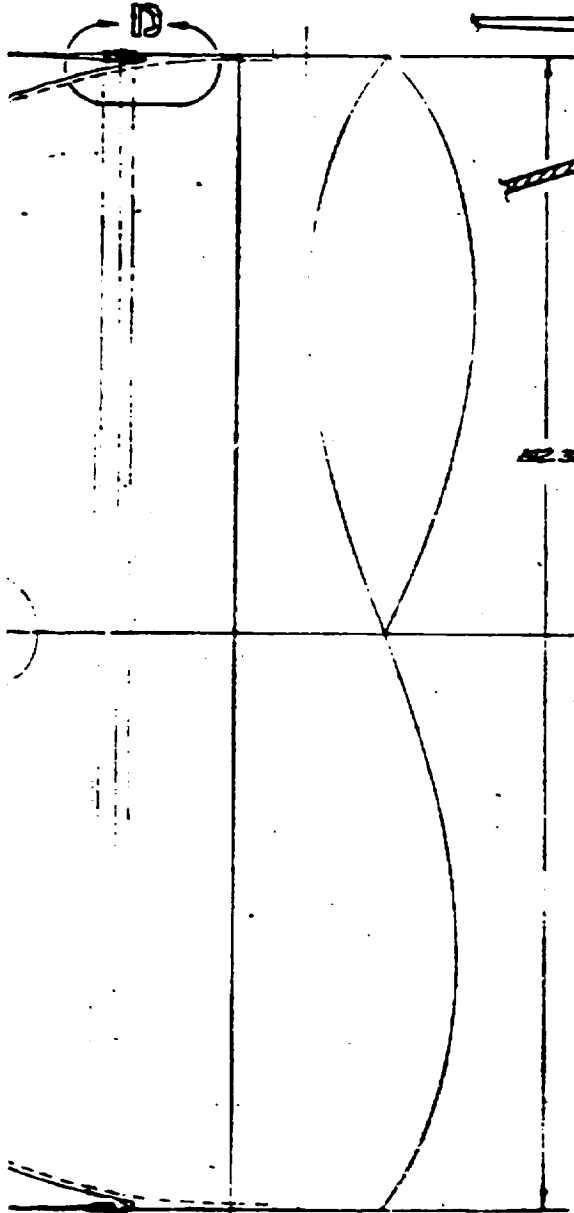

Ø2.30 DIA

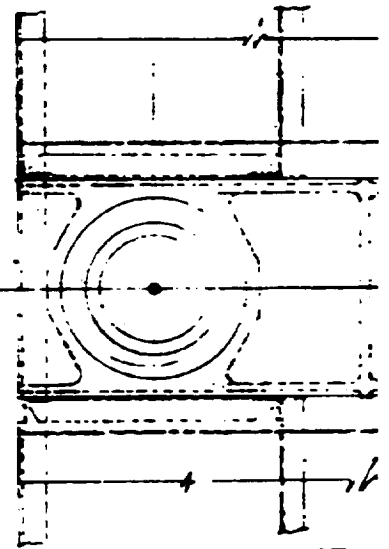
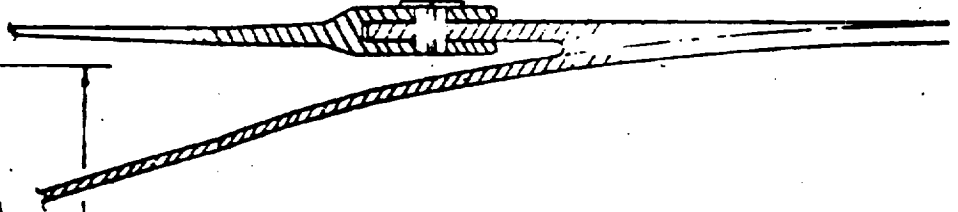

VIEW 0°

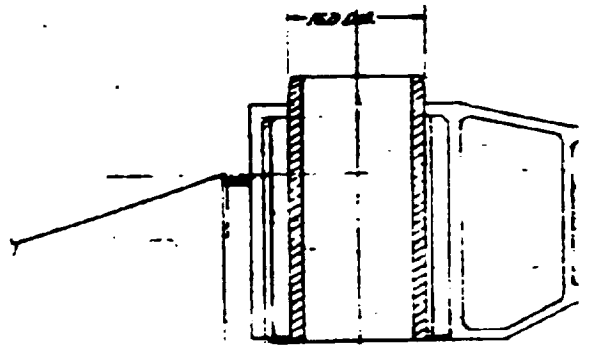

SECTION 0°

2.5796 2.5795(T)

JT FRAME

2/11/4

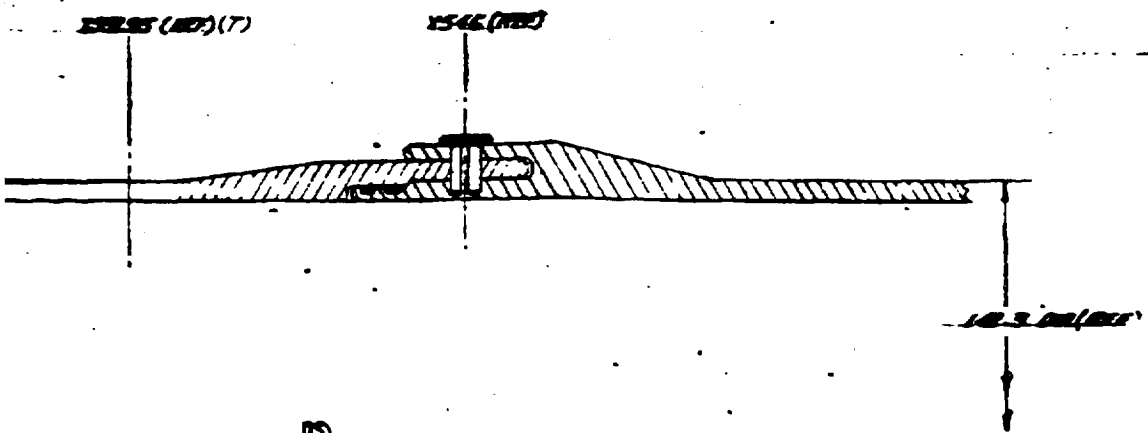

DETAIL D
SCALE: 1/2 SIZE

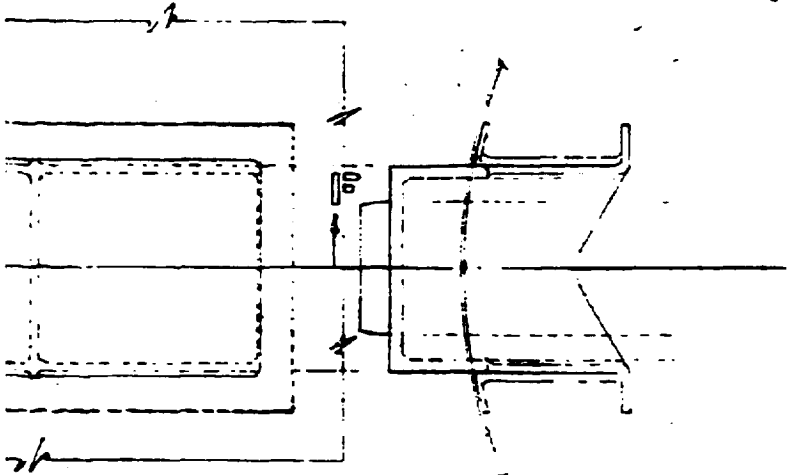

REPRODUCIBILITY OF THIS ORIGINAL PAGE IS POOR

2-4

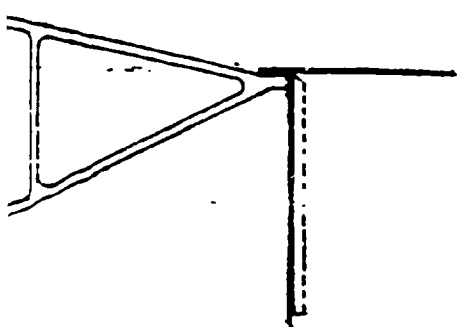

2 FRAME

Figure 1. 2. 2. Solid Rocket Motor Forward Skirt

X5
466.0

X5
523.95

X5
537.3
72

15.5 REF

REPRODUCTION OF THE
ORIGINAL PAGE IS POOR

NUT FRAME

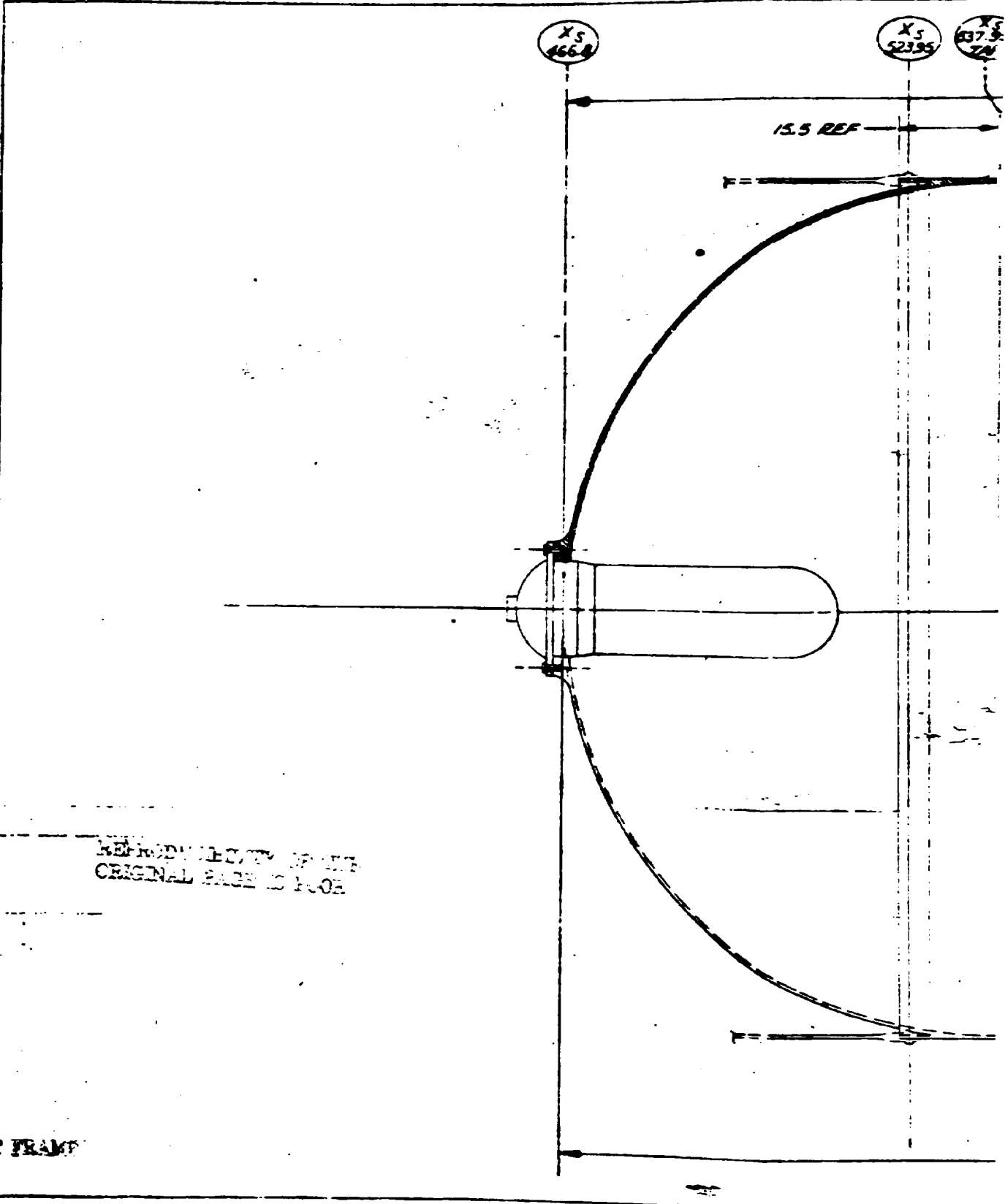

137.35
724

X5
546

X5
694

229.2 REF

REPRODUCIBILITY OF THE
ORIGINAL PAGE IS POOR

X5
696

300 REF
TYP 3 PLACES

FOUR PLACES

3

MANUFACTURING SPLICE

X5
996

150 REF
TYP B PLACES

REPRODUCIBILITY OF THE
ORIGINAL PAGE IS POOR

1358.5 REF
(DOME TO DOME)

1012 REF

4

Xs
1515

ET/SRB AFT
ATTACH FRAME

Xs
1596

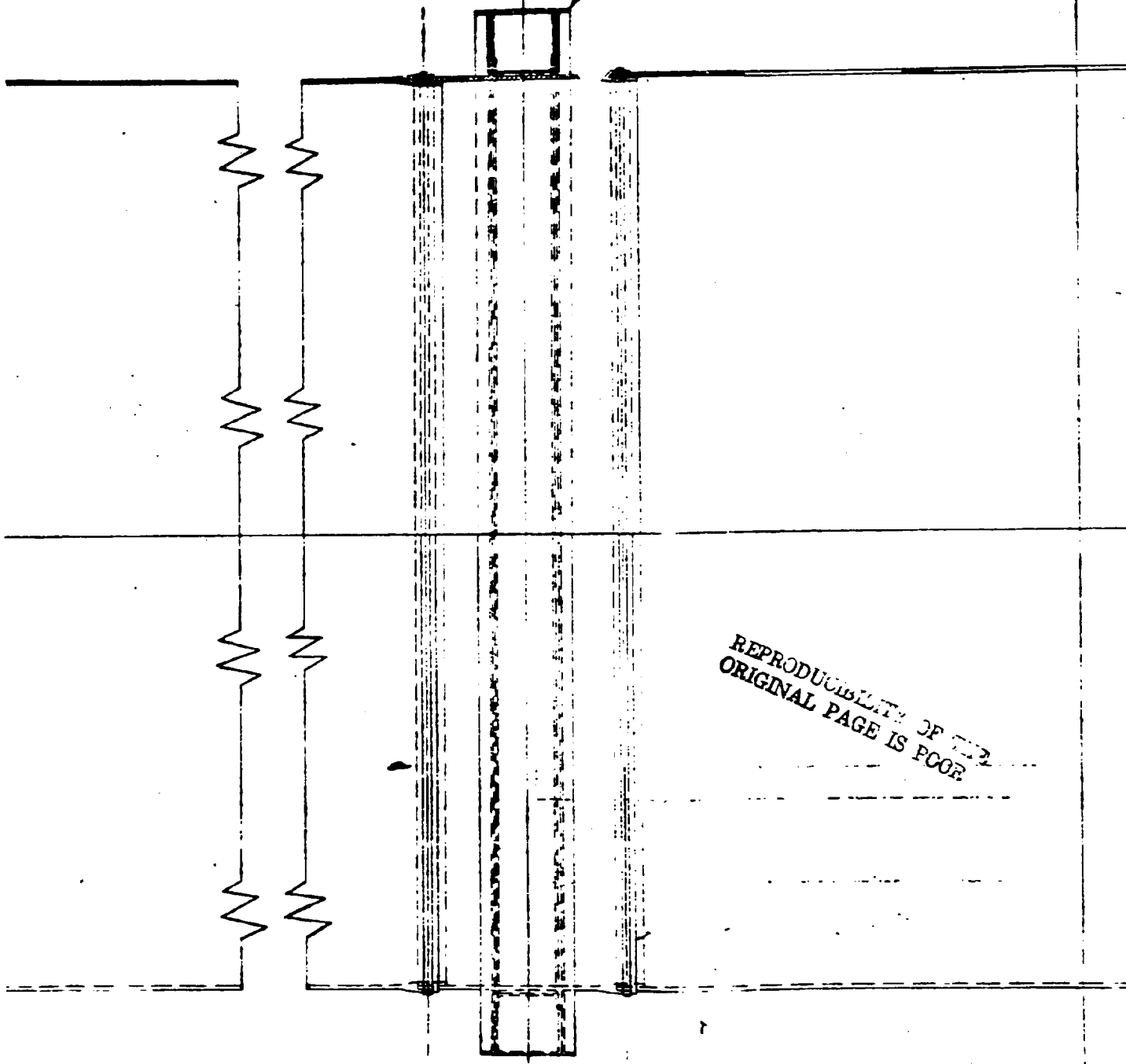

REPRODUCIBILITY OF THIS
ORIGINAL PAGE IS POOR

MECH FR. 1515

5

X5
1596

X5
1746

X5
1754.15
TAN

142.3 DIA

PIVOT POINT

REPRODUCIBILITY OF THE
ORIGINAL PAGES FROM

~~CONFIDENTIAL~~

6

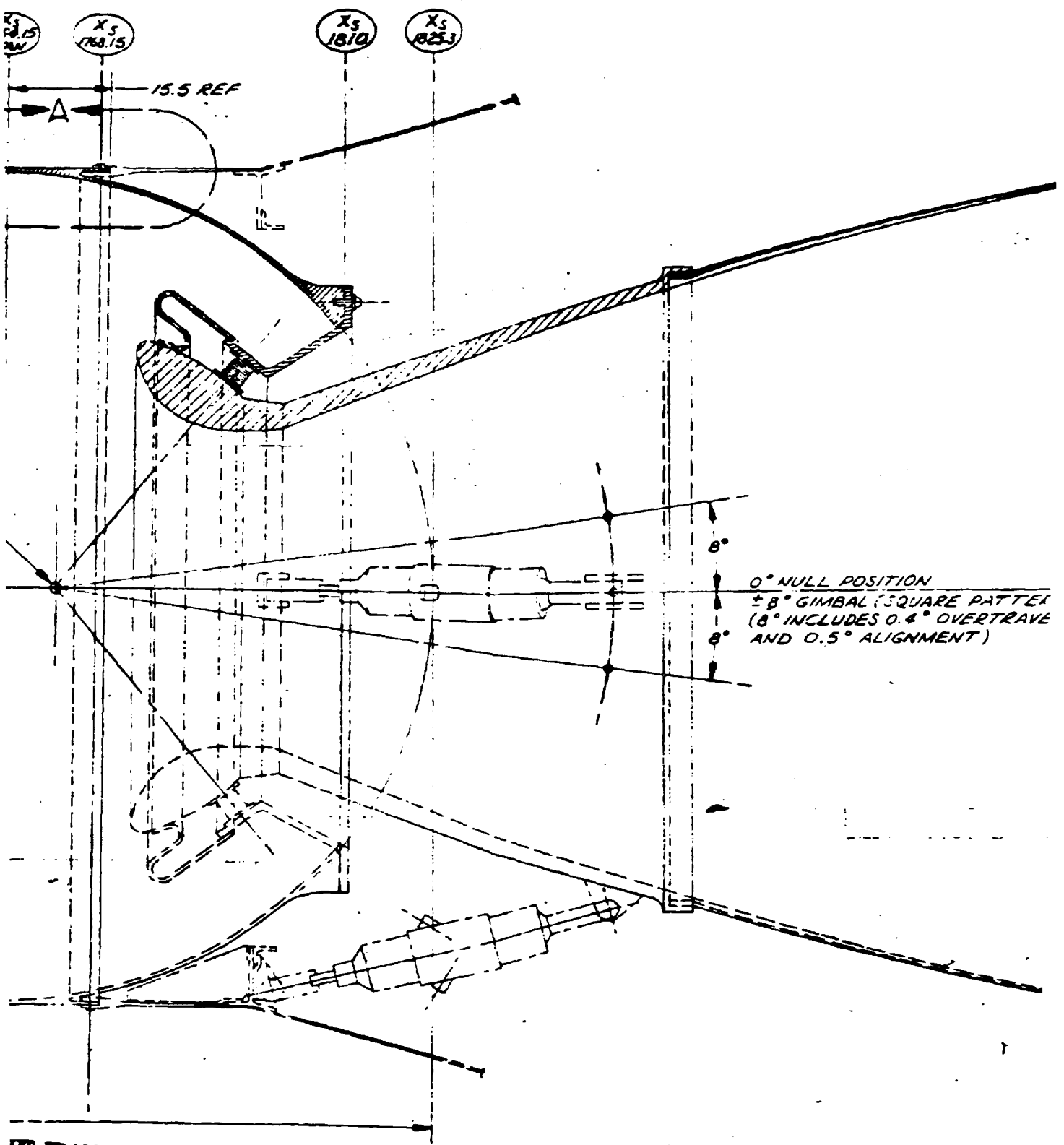

0° NULL POSITION
 $\pm 8^\circ$ GIMBAL (SQUARE PATTERN
 (8° INCLUDES 0.4° OVERTRAVE
 AND 0.5° ALIGNMENT)

UT FRAME



X5
1941

141.3
DIA

INTERNAL
RAVEL

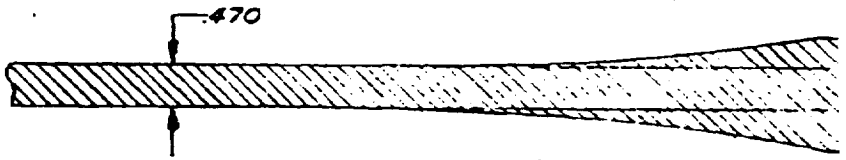

REPRODUCIBILITY OF THE
ORIGINAL PAGE IS POOR

OUT FRAME

8

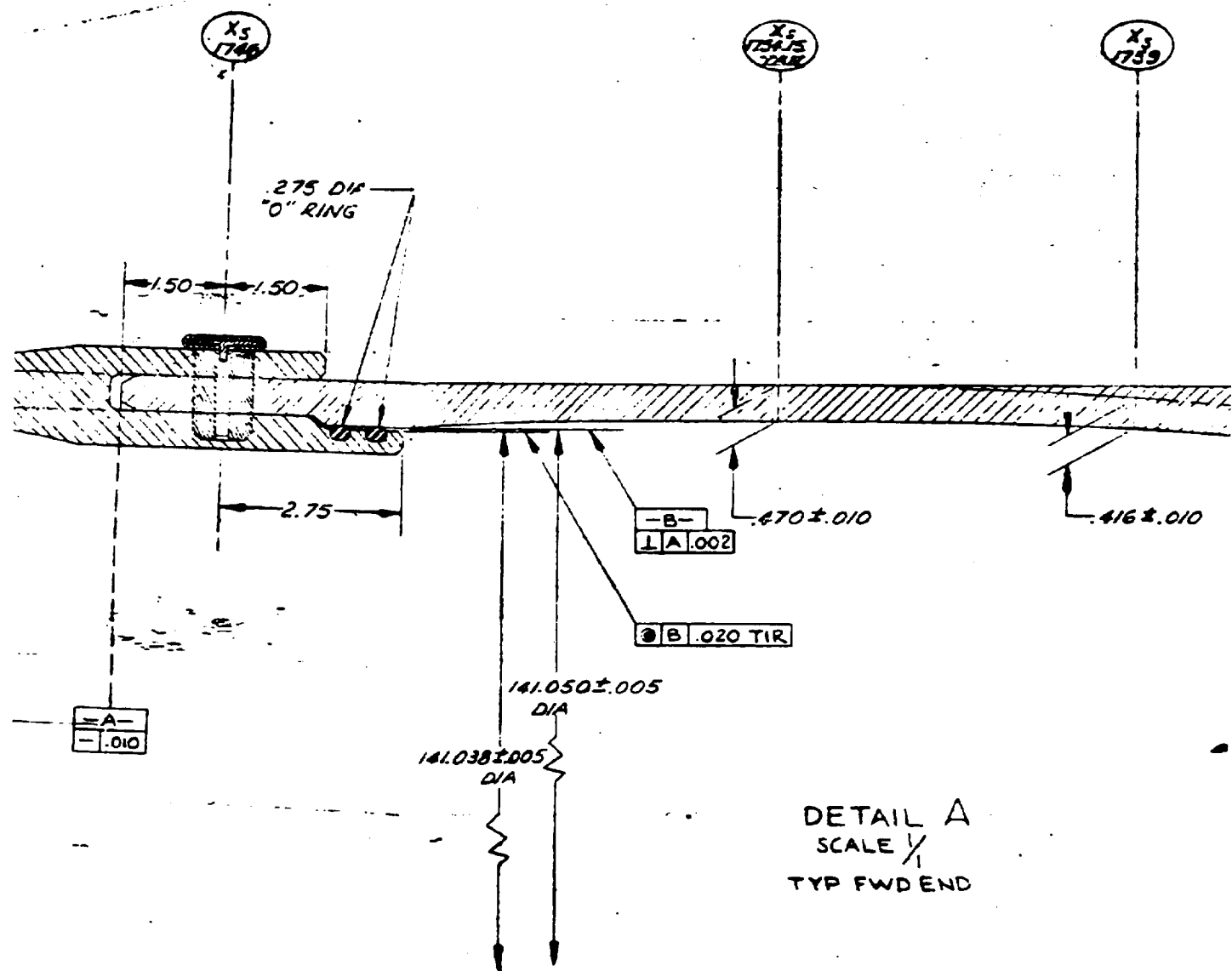

DETAIL A
 SCALE $\frac{1}{1}$
 TYP FWD END

OUT FRAME

9

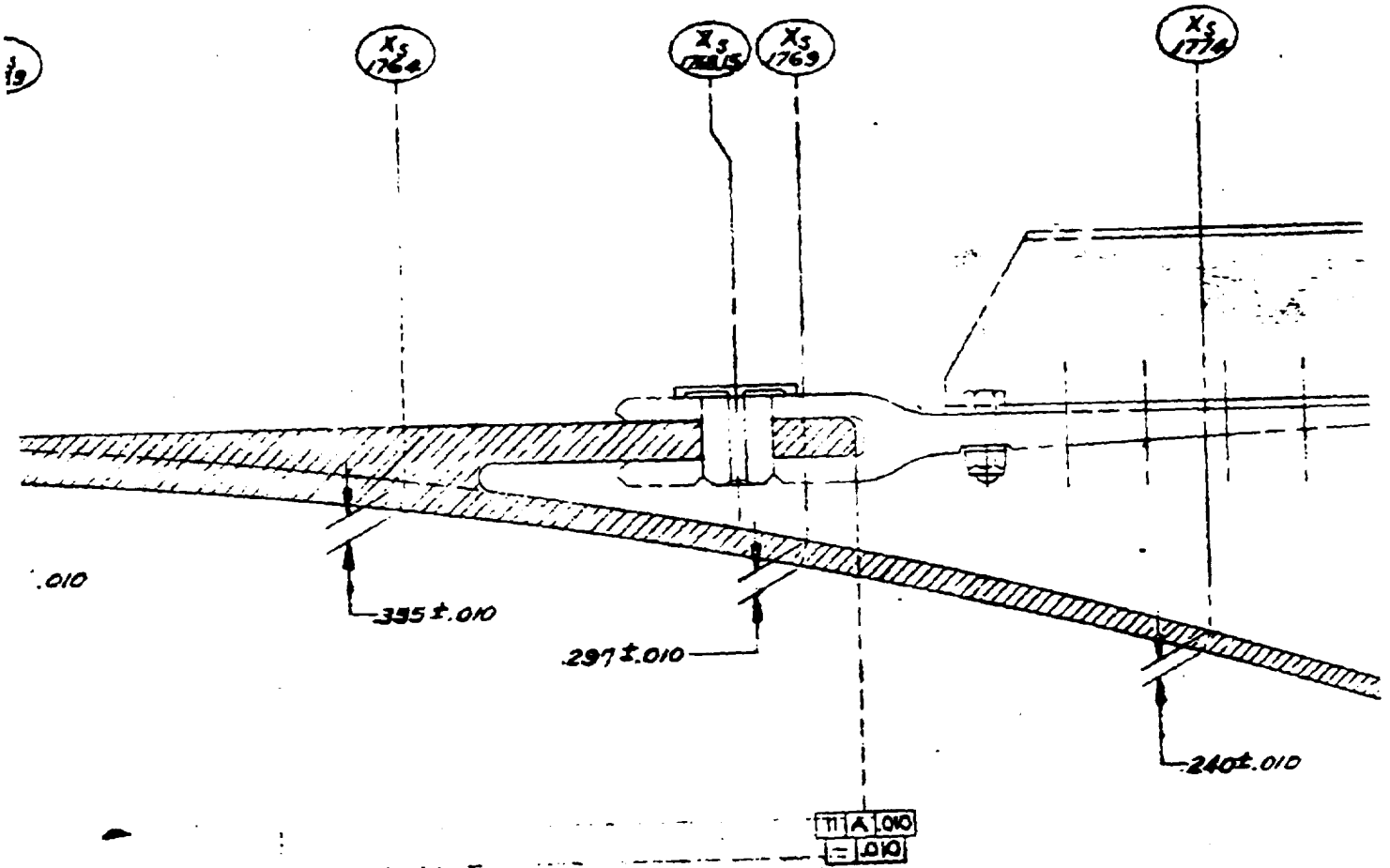

REPRODUCED FROM ORIGINAL DRAWING

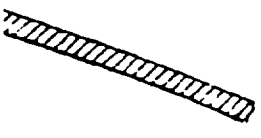
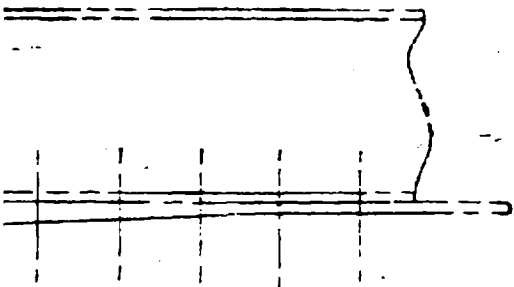
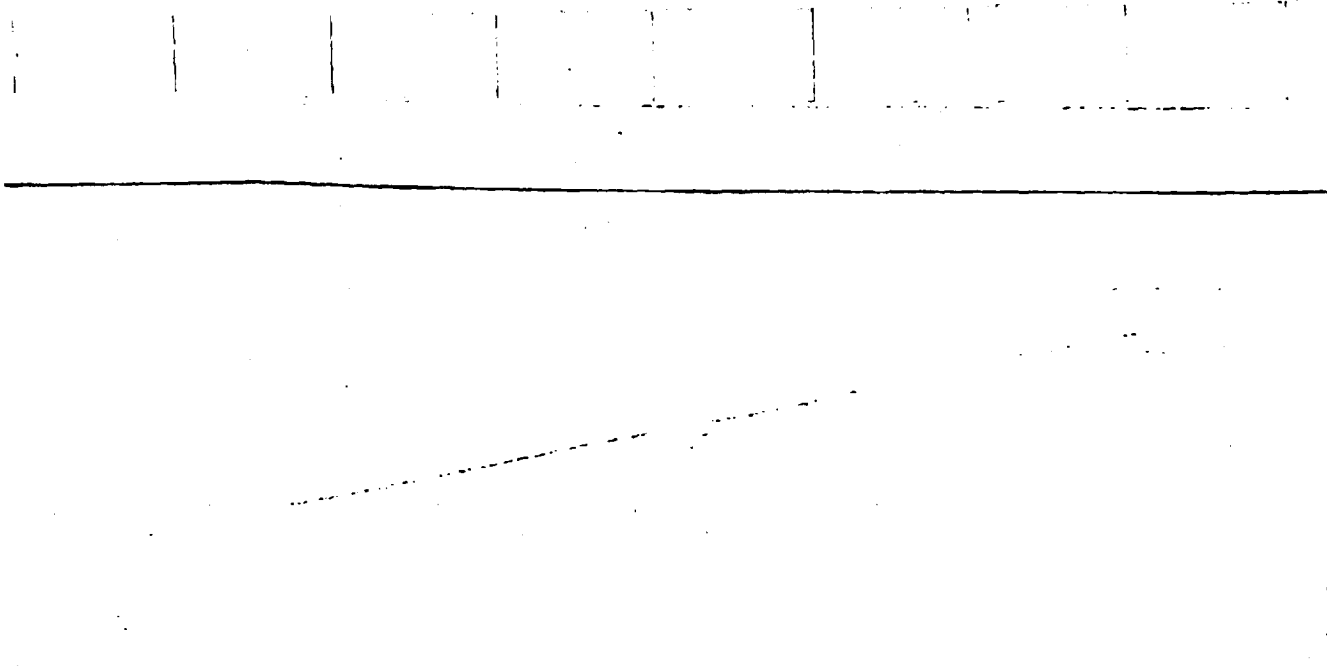

REQUIREMENTS

1. WEIGHT MARGIN INCLUDED IN CONTROL WEIGHT
2% ON SRM INERT WEIGHT
2. NOZZLE CANT ANGLE = ZERO
3. NOZZLE EXPANSION RATIO 7:1 CONTOURED;
T/W AT LIFTOFF = 1.5
4. I_{sp} VAC = 266.3 SEC INITIAL, NOZZLE
EROSION EFFECT TO BE INCLUDED
5. NOZZLE P_c = 737 PSI @ 60°F GRAIN
TEMPERATURE AND MEOP = 900 PSI
6. MACHINED SURFACES:

CASE 125
 CLEVIS 63
 O" RING SURFACES & GROOVES 32

REPRODUCED FROM
 ORIGINAL DRAWING

Figure 1.2.3. Solid Rocket Motor Case

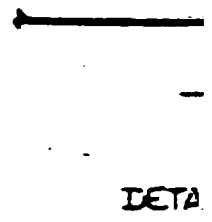
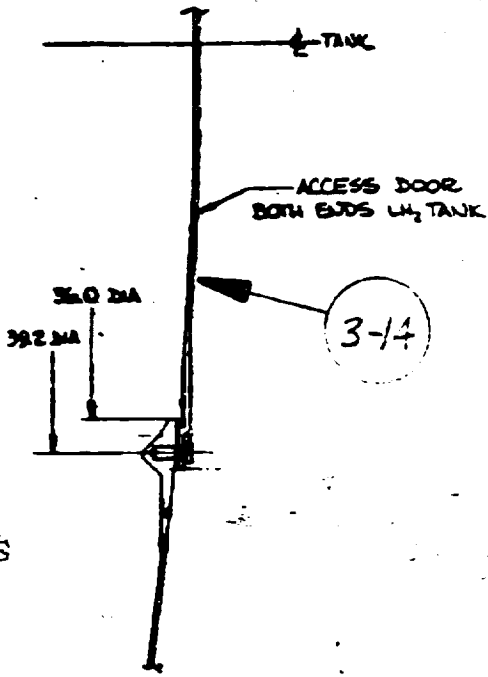

REPRODUCIBILITY OF THE ORIGINAL PAGE IS POOR

SECTION P-P SCALE 1/4

MONOCOQUE
I BEAMS TAPER BE
Z SEAM THICKNES

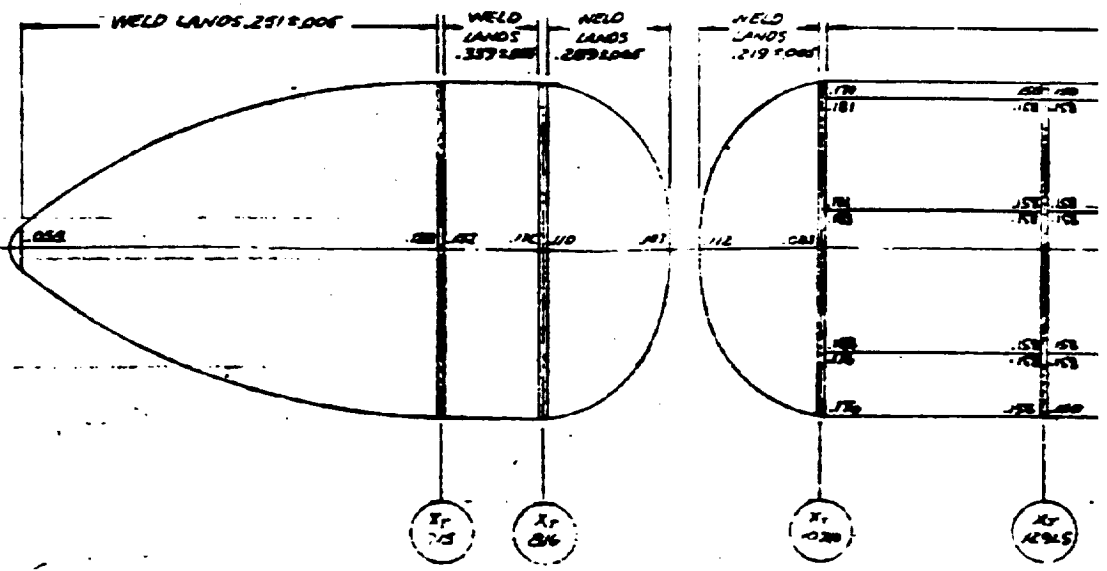

NUY FRAME

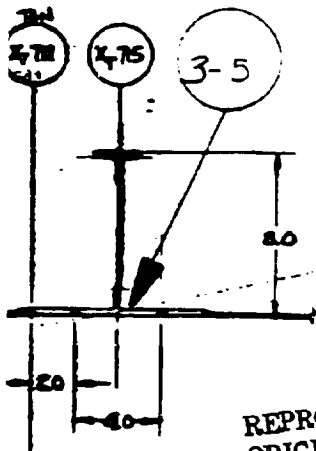

IL N SCALE: 1/2

REPRODUCIBILITY OF THE ORIGINAL PAGE IS POOR

SKIN THICKNESS DIAGRAM

TWENTY DIMS SHOWN
DIM TOLERANCE ±.005

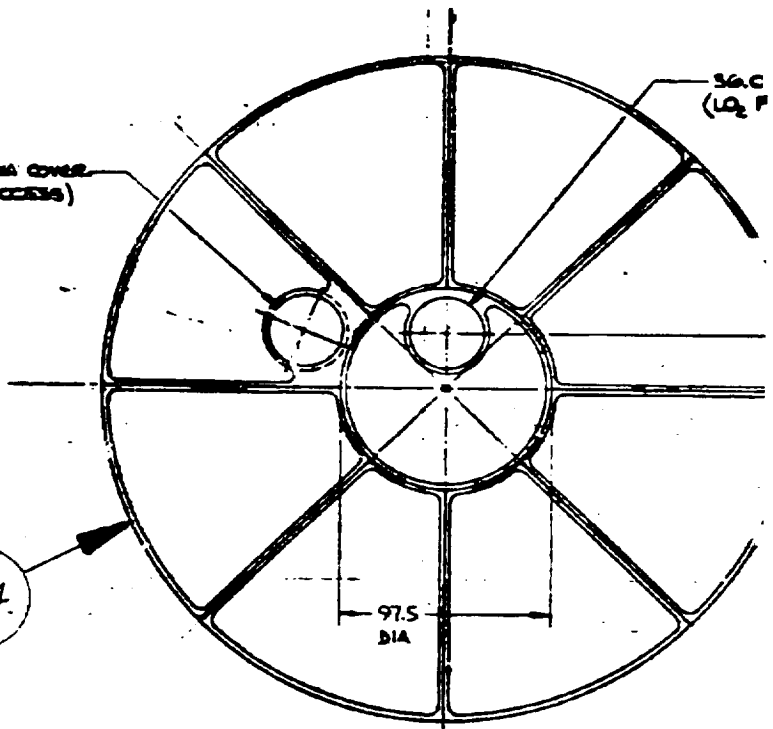
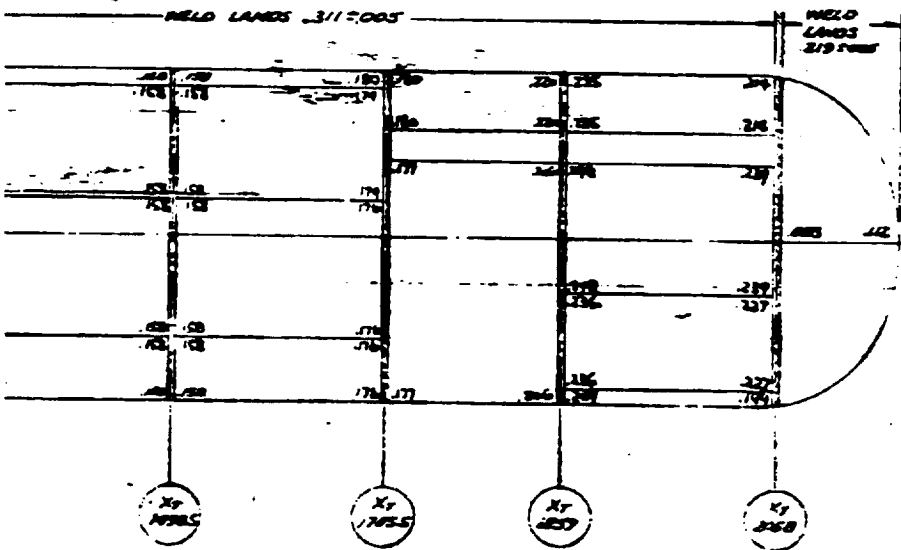

SECTION L-L
SCALE: 1/40
AFT DOME-LO₂ TANK

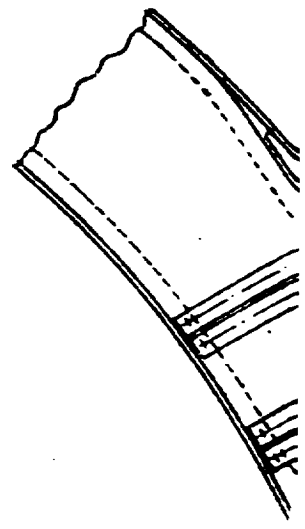

SECTION M-M
SCALE: 1/10
ORBITER THRUST FITTING
STA X71059

AME

—36.0 DIA
(LO₂ FEED LINE)

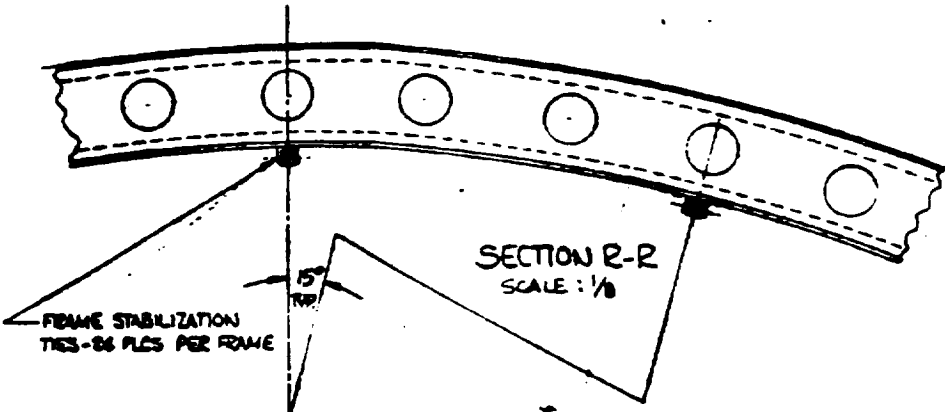
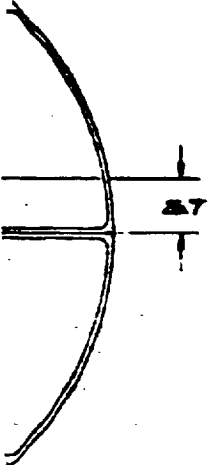

FRAME STABILIZATION
TIES—26 PLS PER FRAME

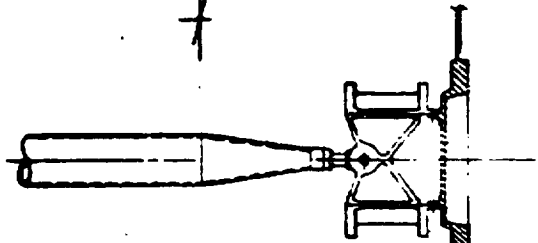

REPRODUCIBILITY OF THE
ORIGINAL PAGE IS POOR

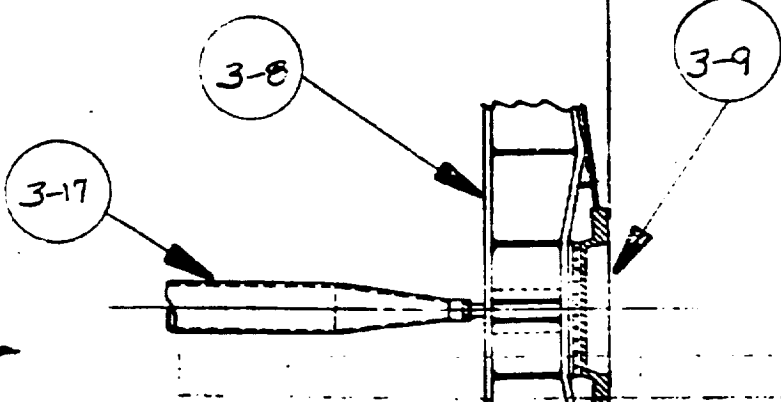

SECTION W-W
SCALE: 1/10
STA X₄ 947
S2B THRUST FITTING

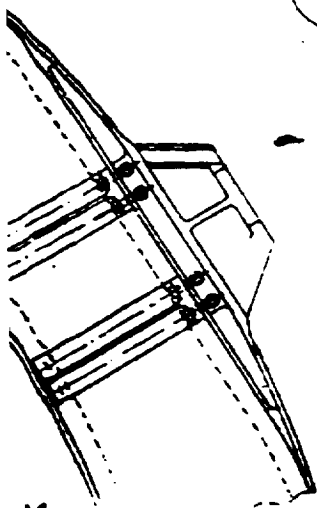

OUT FRAME

4215

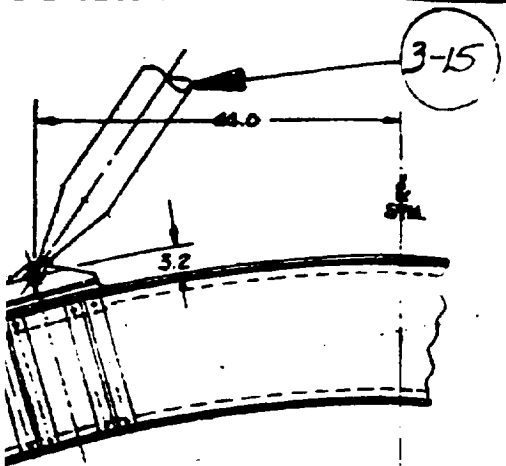

SECTION J-J SCALE: 1/10

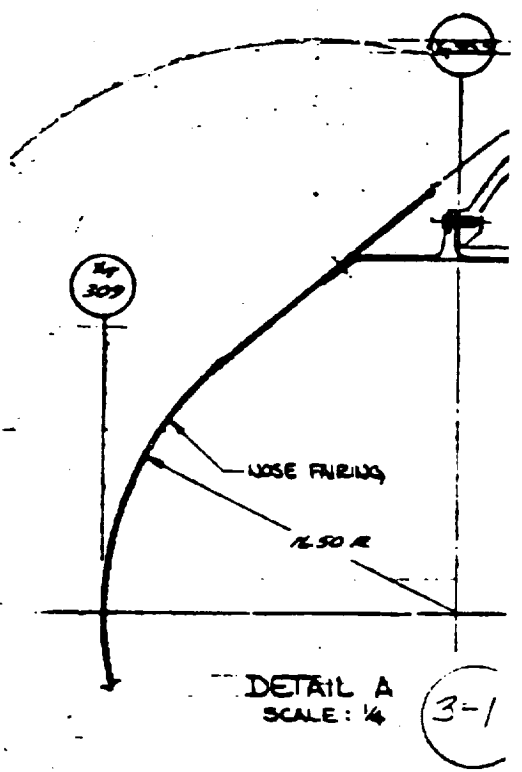

DETAIL A SCALE: 1/4

REPRODUCIBILITY OF THE ORIGINAL PAGE IS GOOD

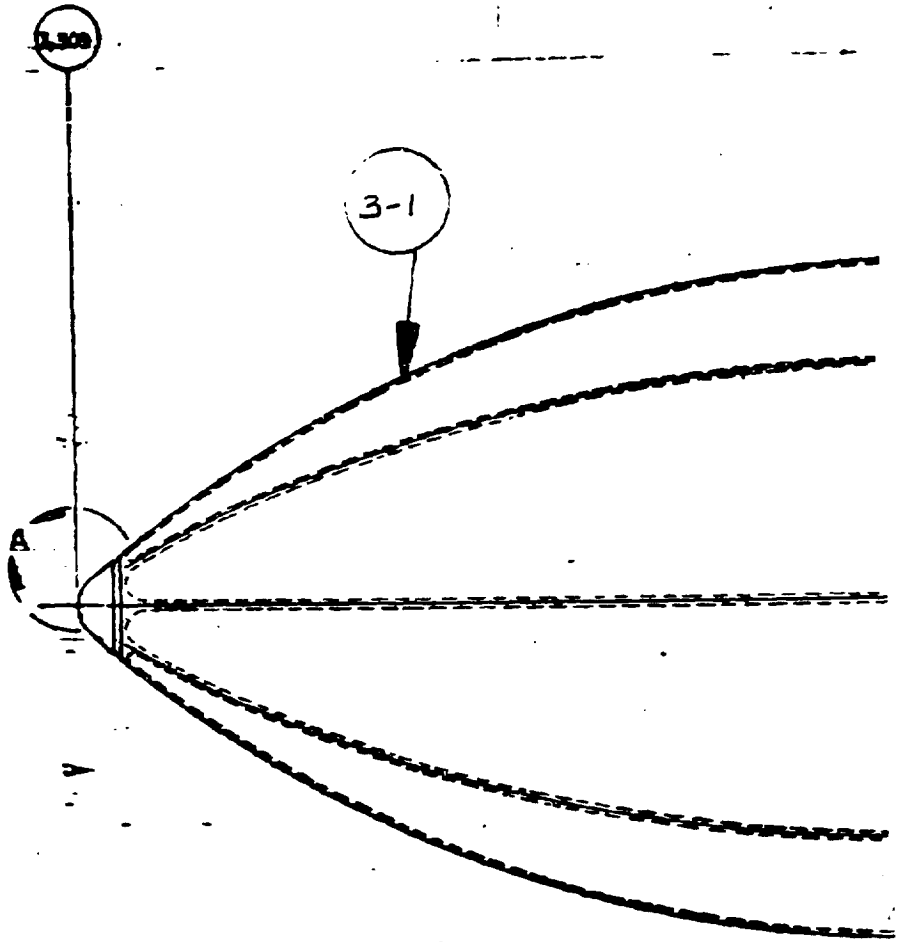
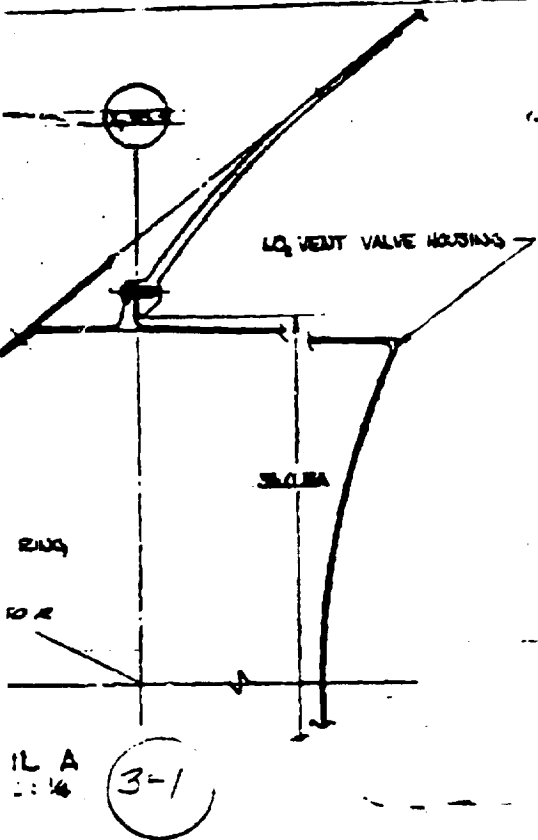

REPRODUCED FROM ORIGINAL DRAWING

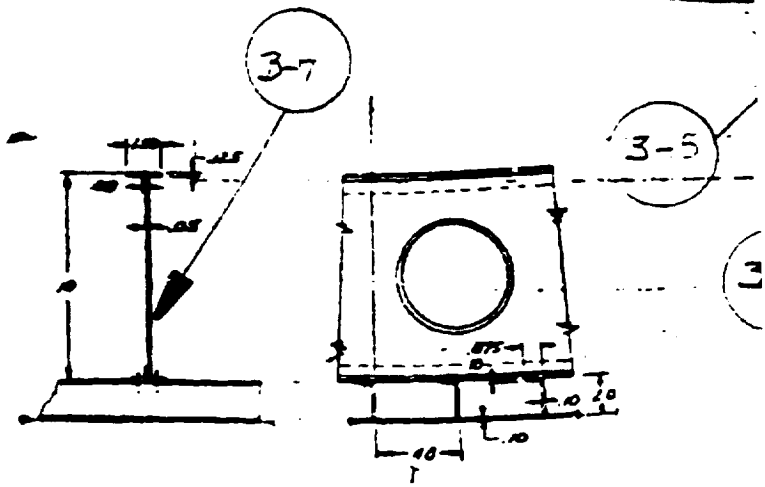

SECTION K-K
SCALE: 1/4
INTERTANK STRUCTURE

BOLT PATTERN

3 (M5)

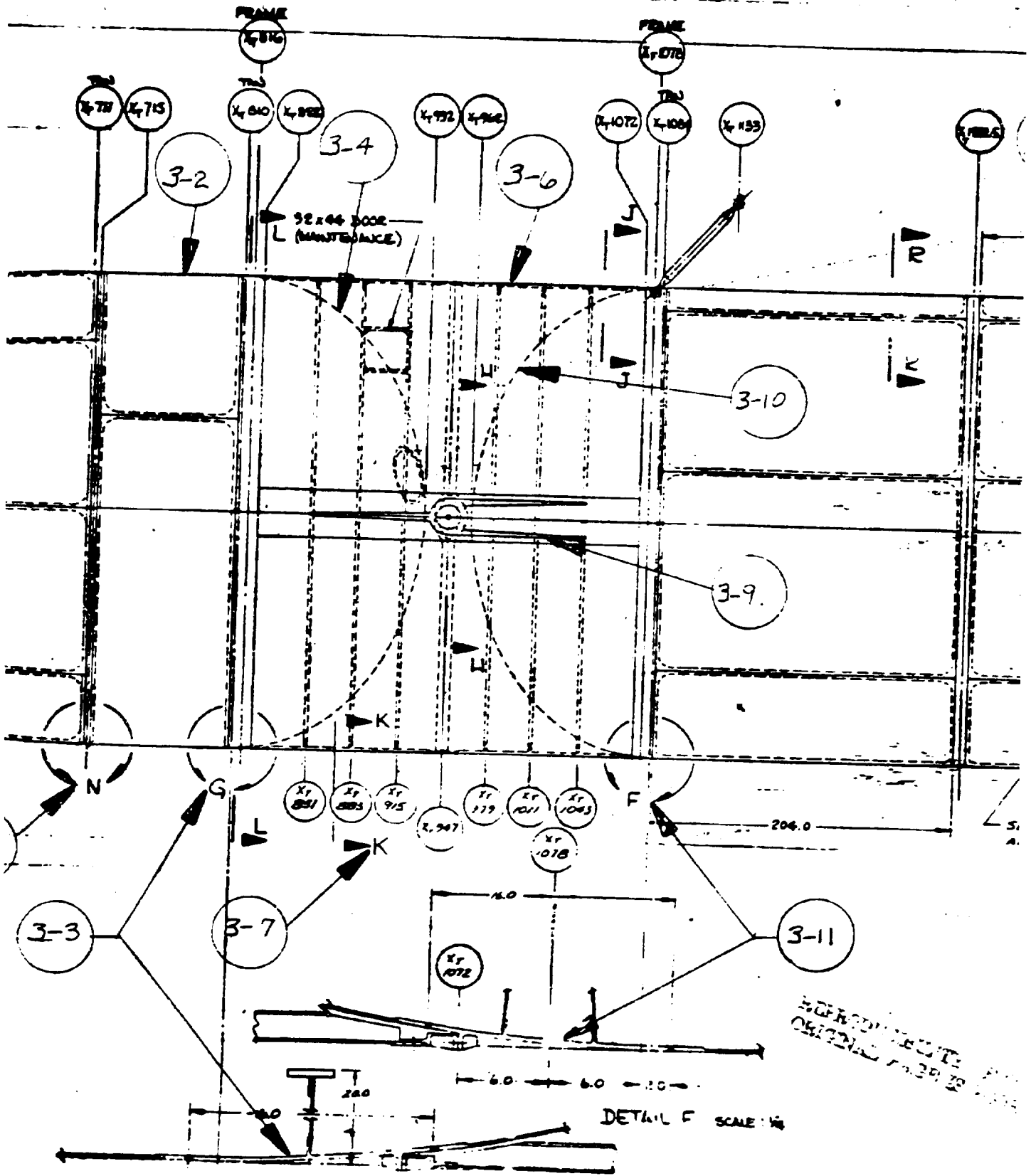

REVISIONS
 ORIGINAL 10/29/53

DETAIL F SCALE: 1/4"

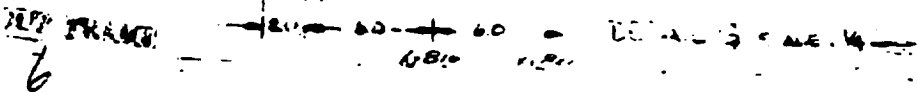

VL78-0

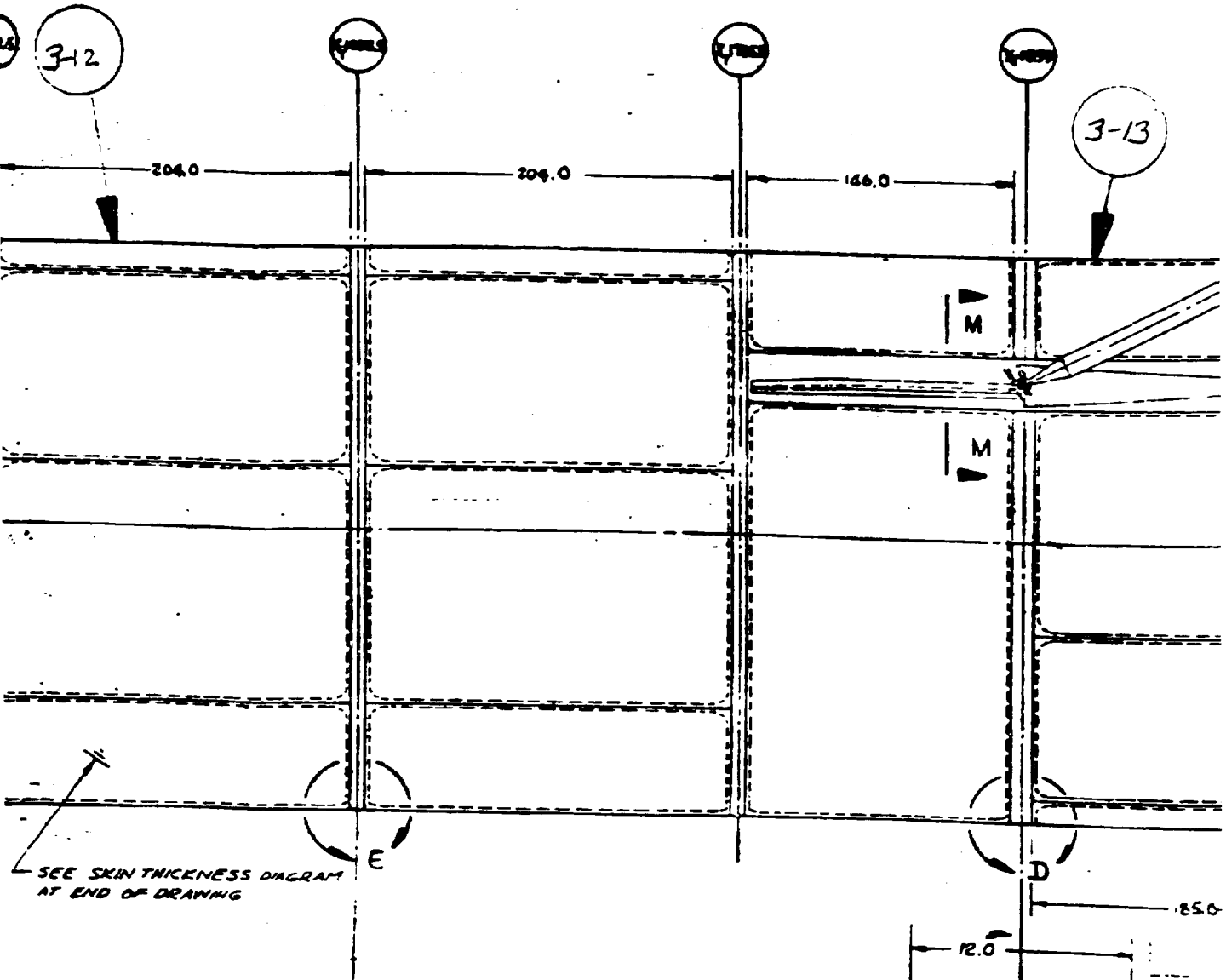

SEE SKIN THICKNESS DIAGRAM
AT END OF DRAWING

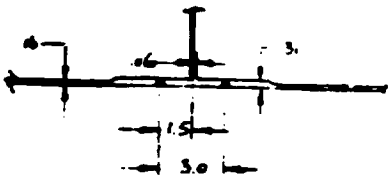

DETAIL E SCALE: 1/4
BY 120'S X 40'S & X-70'S

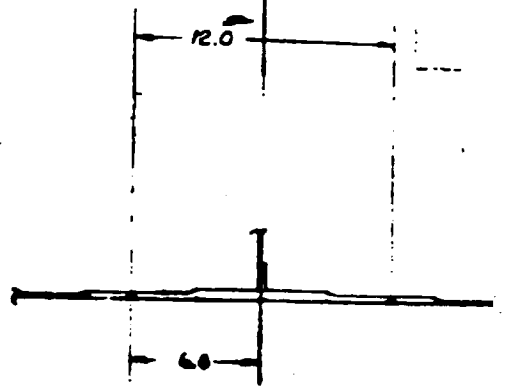

DETAIL D SCALE: 1/4

EXPERT WORKS

-000024 A

2015

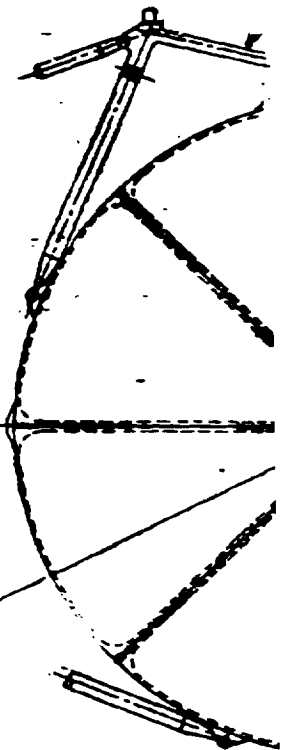
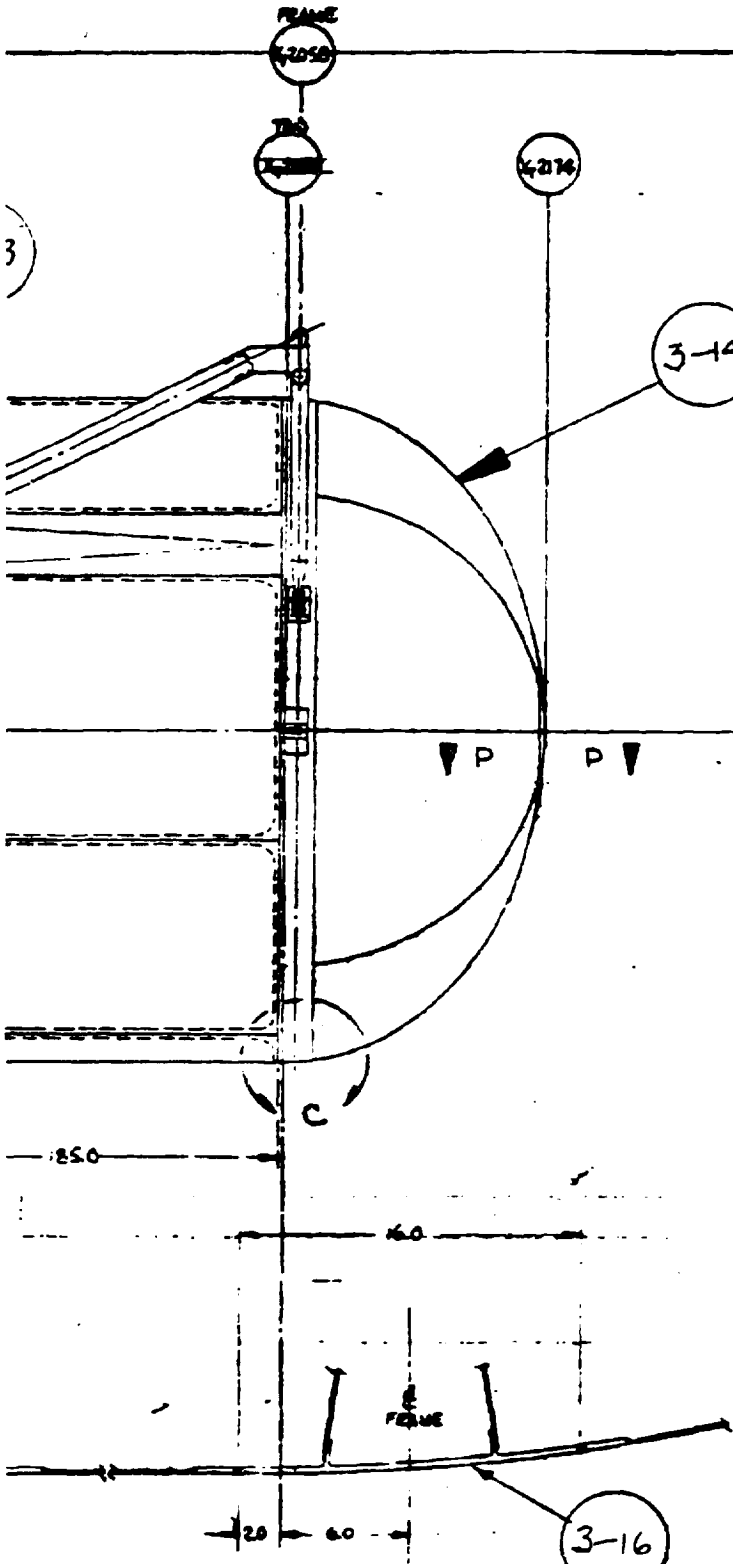

REPRODUCIBILITY OF THE ORIGINAL PAGE IS POOR

DETAIL C SCALE 1/4

FRAME FRAMES
8

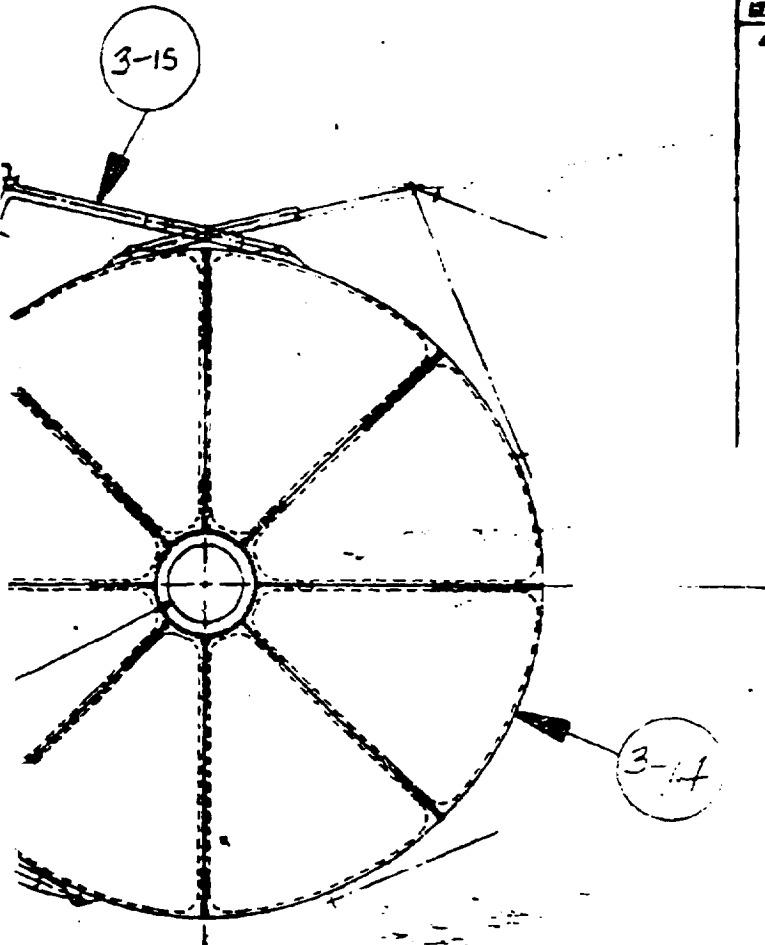

REV	CHANGE
4	1. ADDED SECTIONS & DETAILS FOR THRU R-R 2. ADDED FRAME STABILIZATION FOR LH TANK 3. RELOCATED ACCESS DOOR IN INTERTANK 4. ADDED REQUIREMENT NOTE 7 5. REMOVED DECORATIVE MOTOR FROM NOSE 6. REVISED DETAIL A & DELETED SECTION B-B 7. REVISED THICKNESSES IN SKIN THICKNESS DIAGRAM 8. REVISED PANEL WIDTHS & FRAME STATIONS IN LH TANK 9. REMOVED AFT SKIRT & WEATERSHIELD SUPPORT 10. 'A' BASELINE QMS AUTHORIZED PER MCR 0200 REVIEW & DATED 5-16-73

REPRODUCIBILITY OF THE ORIGINAL PAGE IS POOR.

REQUIREMENTS/ASSUMPTIONS

1. 306 IN. DIA EXTERNAL TANK
2. SOB TO E/T THRUST ATTACHMENT IN E/T INTERTANK AT X=357
3. SOB TO E/T AFT ATTACHMENT AT X=2058
4. ORBITER TO E/T FWD ATTACHMENT AT X=1078
5. ORBITER TO E/T AFT THRUST ATTACHMENT AT X=2058
6. MONOCOQUE CONSTRUCTION FOR LO₂ & LH₂ TANKS
7. UNSUPPORTED ORBITER CONCEPT
8. LO₂ & LH₂ TANKS - 2019-157A-111 ALLN
9. INTERTANK - 2029 ALLN ALLGT

Figure 1.3.1. External Tank Structural Assembly

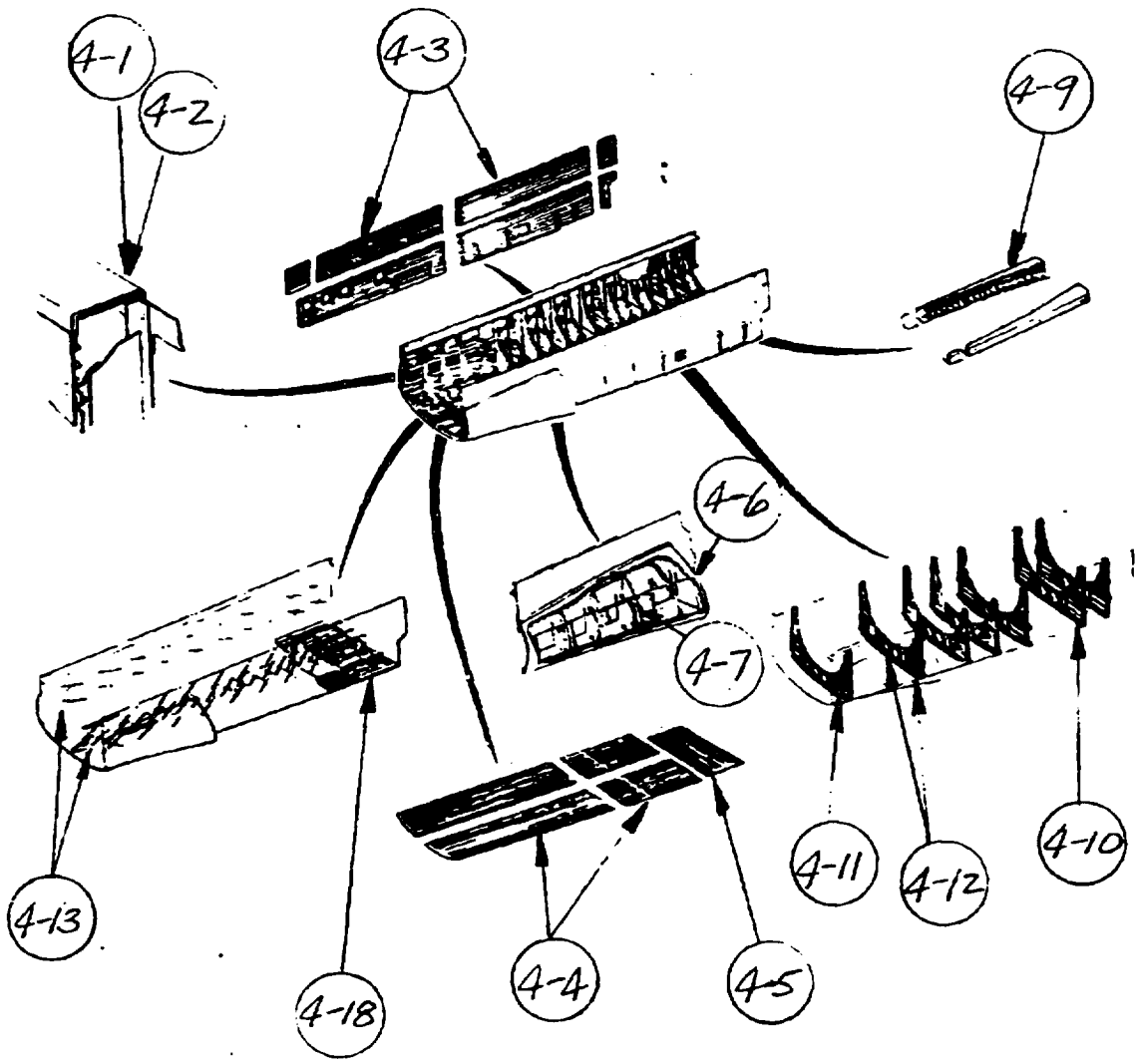
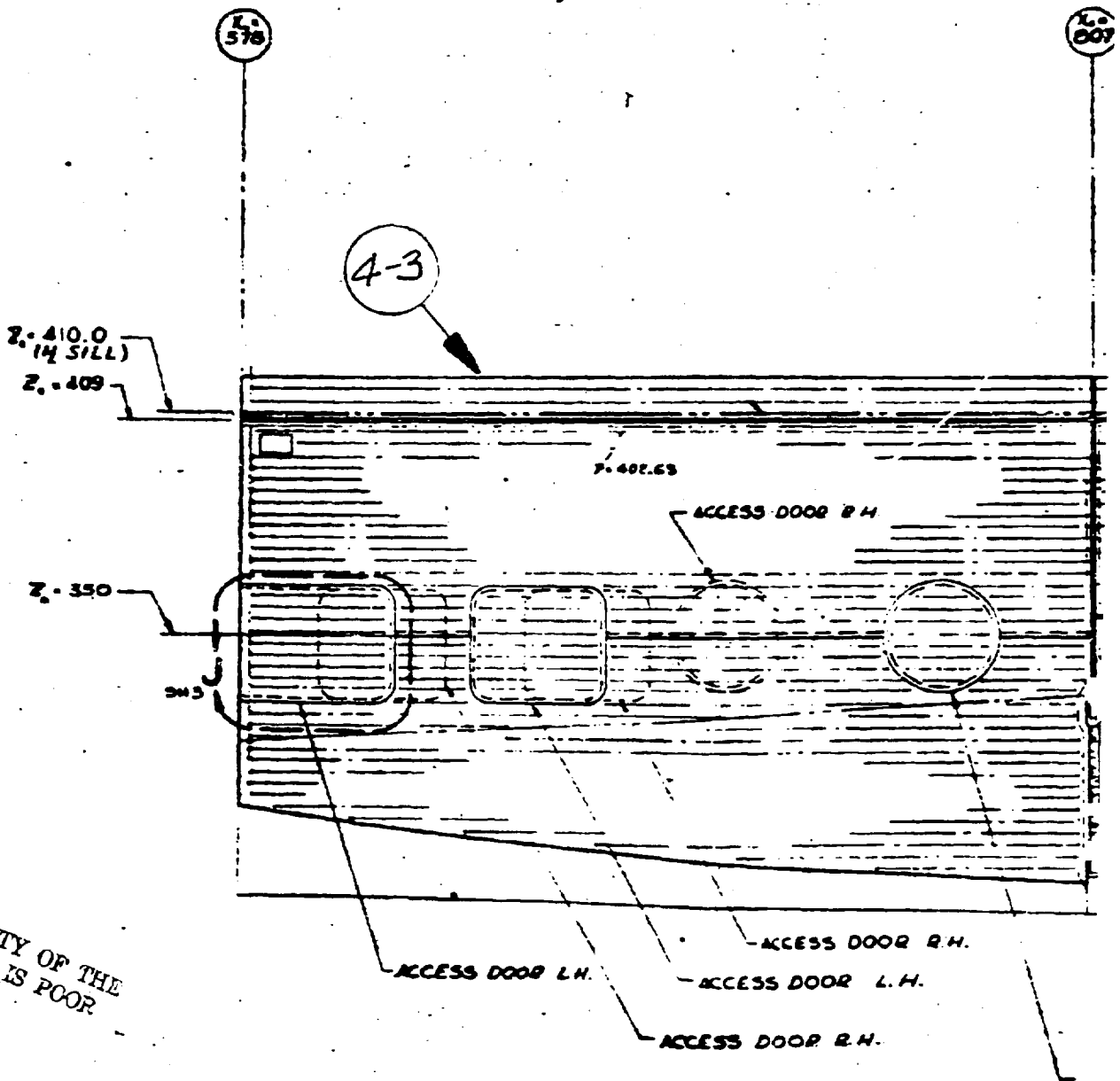

Figure 1.4.1. Mid Fuselage Structure



REPRODUCIBILITY OF THE ORIGINAL PAGE IS POOR

YOUR NAME

X-2
007

X-2
1000

R_{ms}

R

P

P_{ms}

-2-356

SM 3

E

ACCESS DOOR R.H.
SERVICE DOOR L.H.
(WINGED)

ACCESS DOOR L.H.

ACCESS DOOR
L.H. & R.H.
INTERNAL
SEE NOT.

REPRODUCIBILITY OF THIS
ORIGINAL PAGE IS POOR

FIXED PAGE

2

LTR	
A	REVERSED
6-878	CONTONE
846	CORRECT.
	34 2 RE
	ADDED

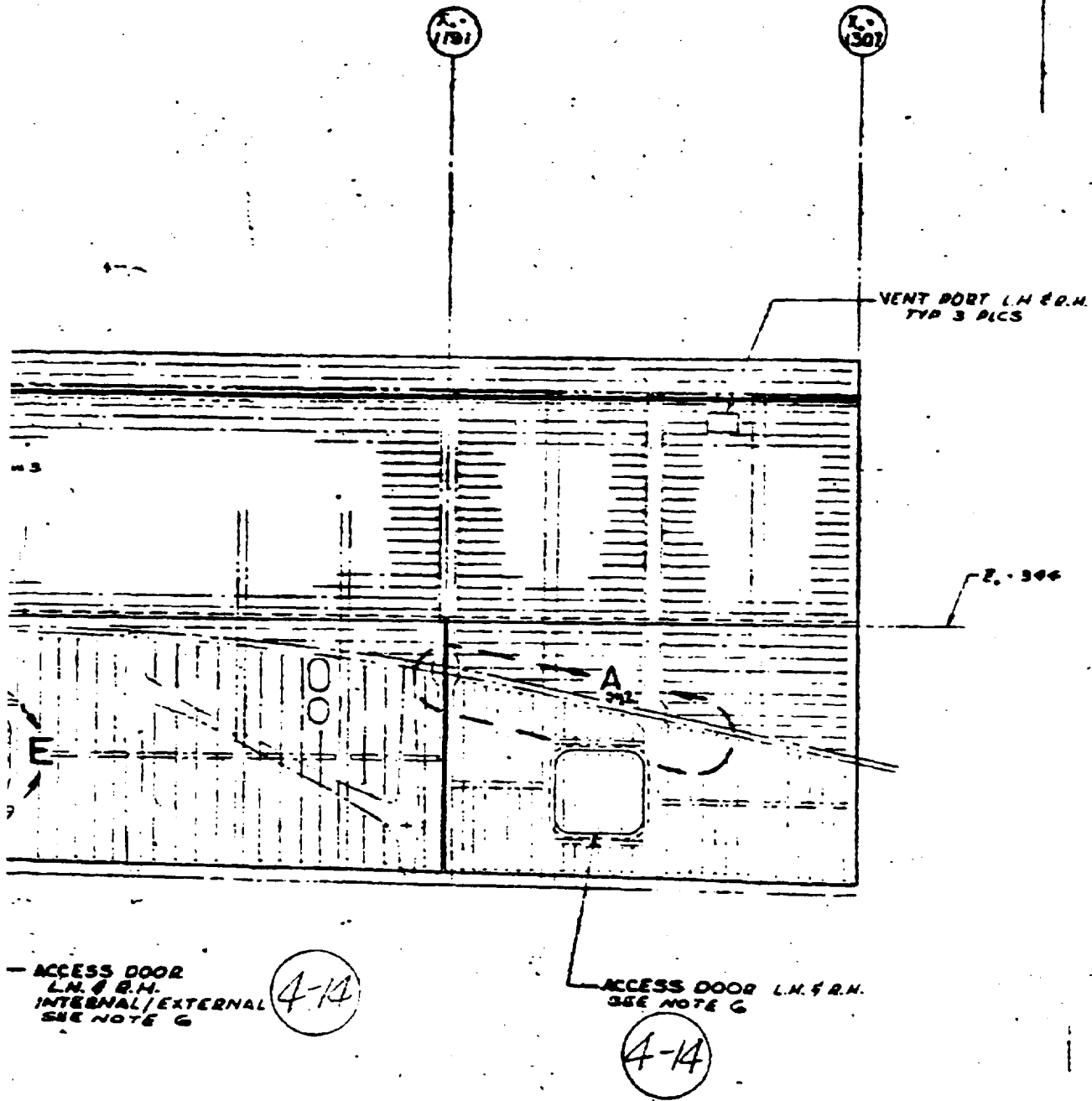
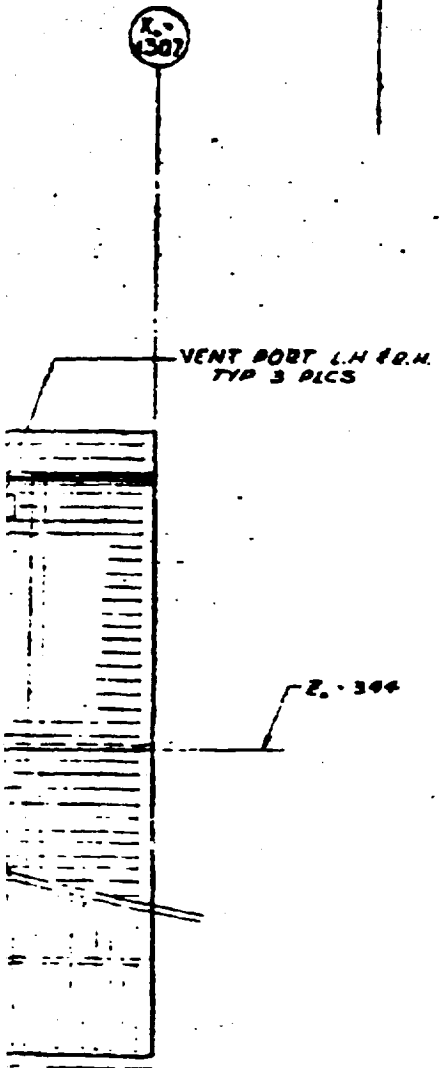

Figure 1.4.2. Mid 7



K. 307

LTR	REVISION
A	REVERSED DIRECTION OF STIFFENERS BELOW WING CONTOUR J, - 1040 TO L, - 307 CORRECTED HORIZ SPLICE 2' LINE SH 2. REDRAWN ADDED SH 3

NOTES

1. MACHINED LANDS WILL EXIST AT EACH FRAME.
2. SKIN THICKNESSES VARY ON EACH INDIVIDUAL SKIN PANEL
3. ALL DOORS ARE INTEGRALLY STIFFENED DETAILS.
4. ALL SKINS ARE FLAT PANELS
5. ALL STRINGERS ARE TEES AND SPACED AT APPROX 3.25 INCHES
6. ACCESS DOOR AT L. 1050 & X. 730 WILL NOT REQUIRE MACHINED RECESSES ON OUTSIDE OF SKIN.

REPRODUCIBILITY OF ORIGINAL PAGES IS ASSURED

Figure 1.4.2. Mid Fuselage Side Panels

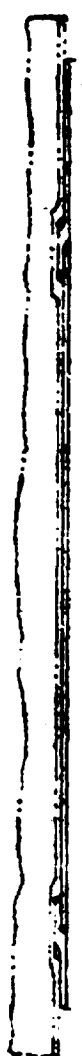

M-M

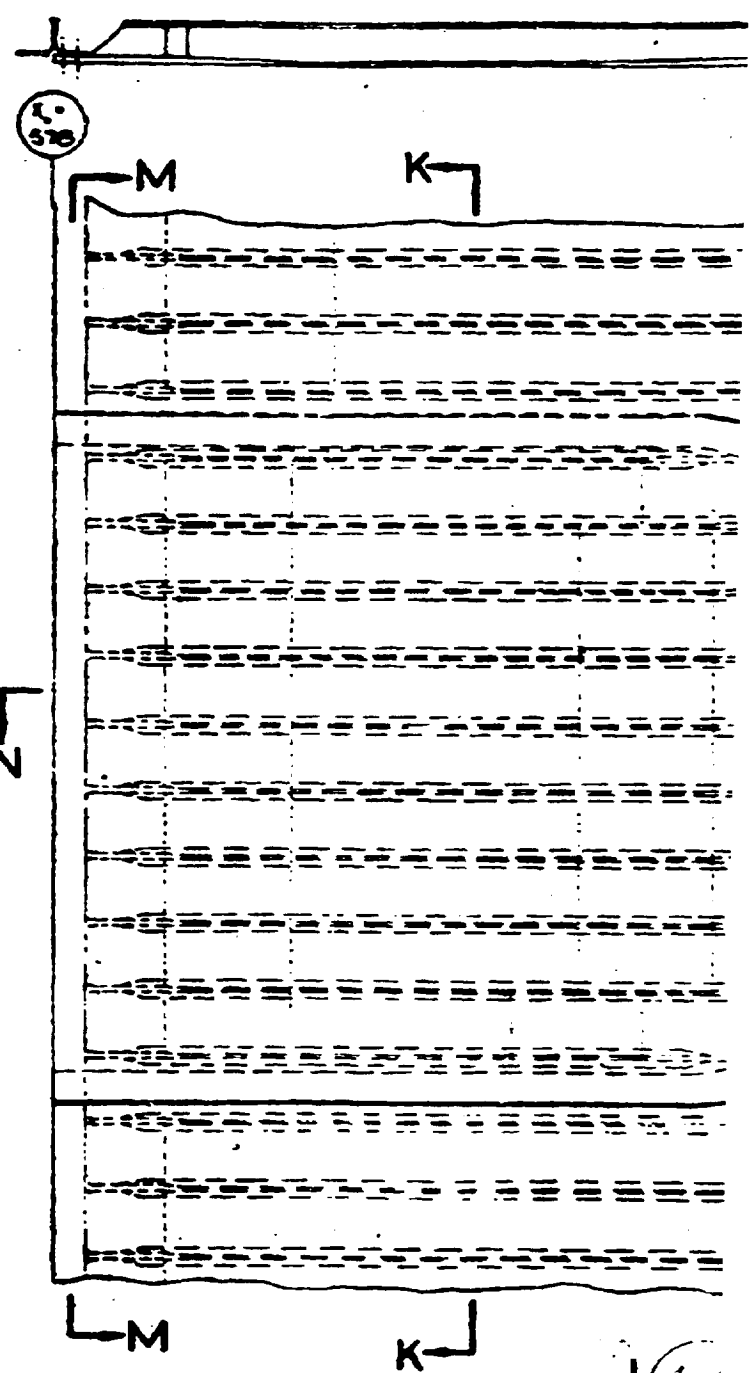

578

M

K

J 41

BOLTED FRAME

REPRODUCIBILITY OF THE ORIGINAL PAGE IS POOR

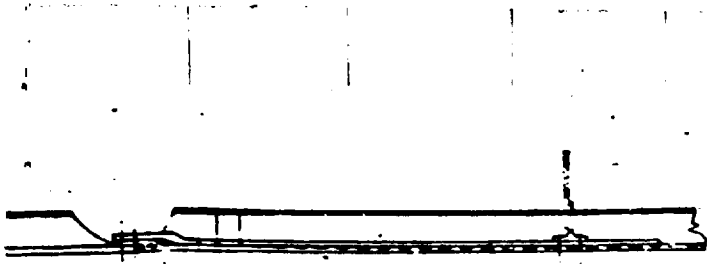

N-N

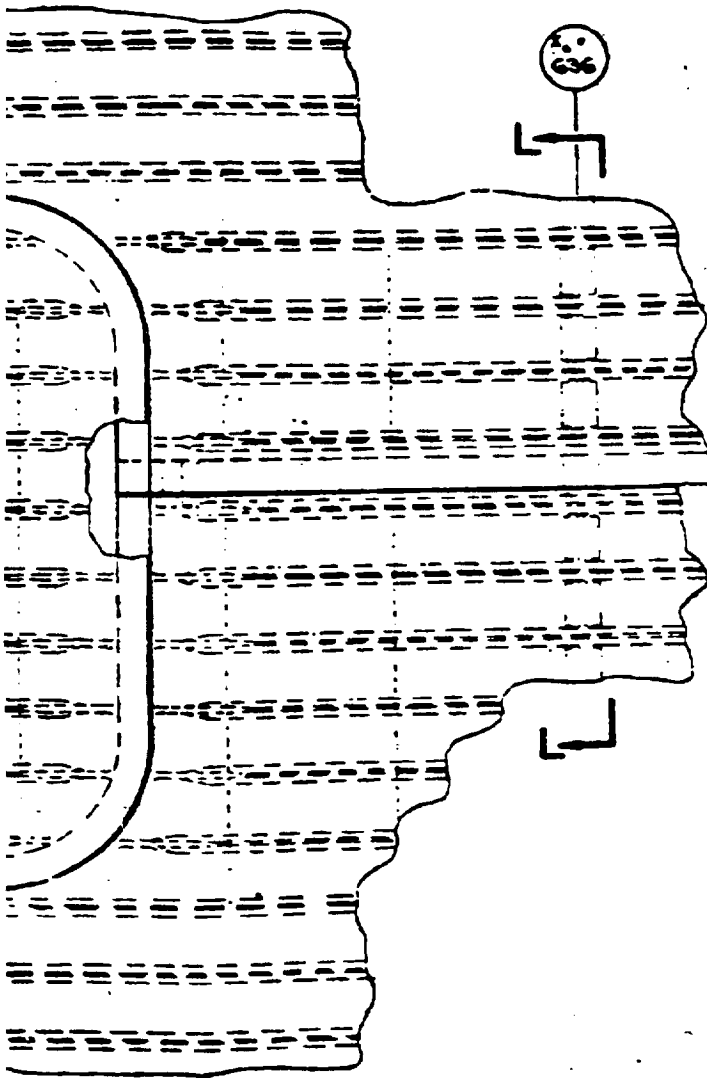

28

N

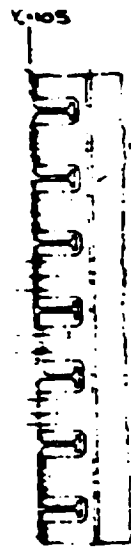

TYP HORIZ SPLICE

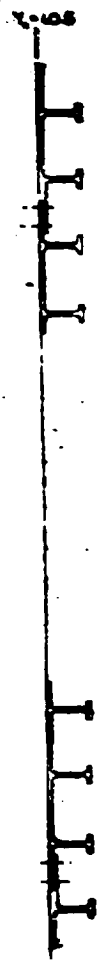

K-K

14

FRAME

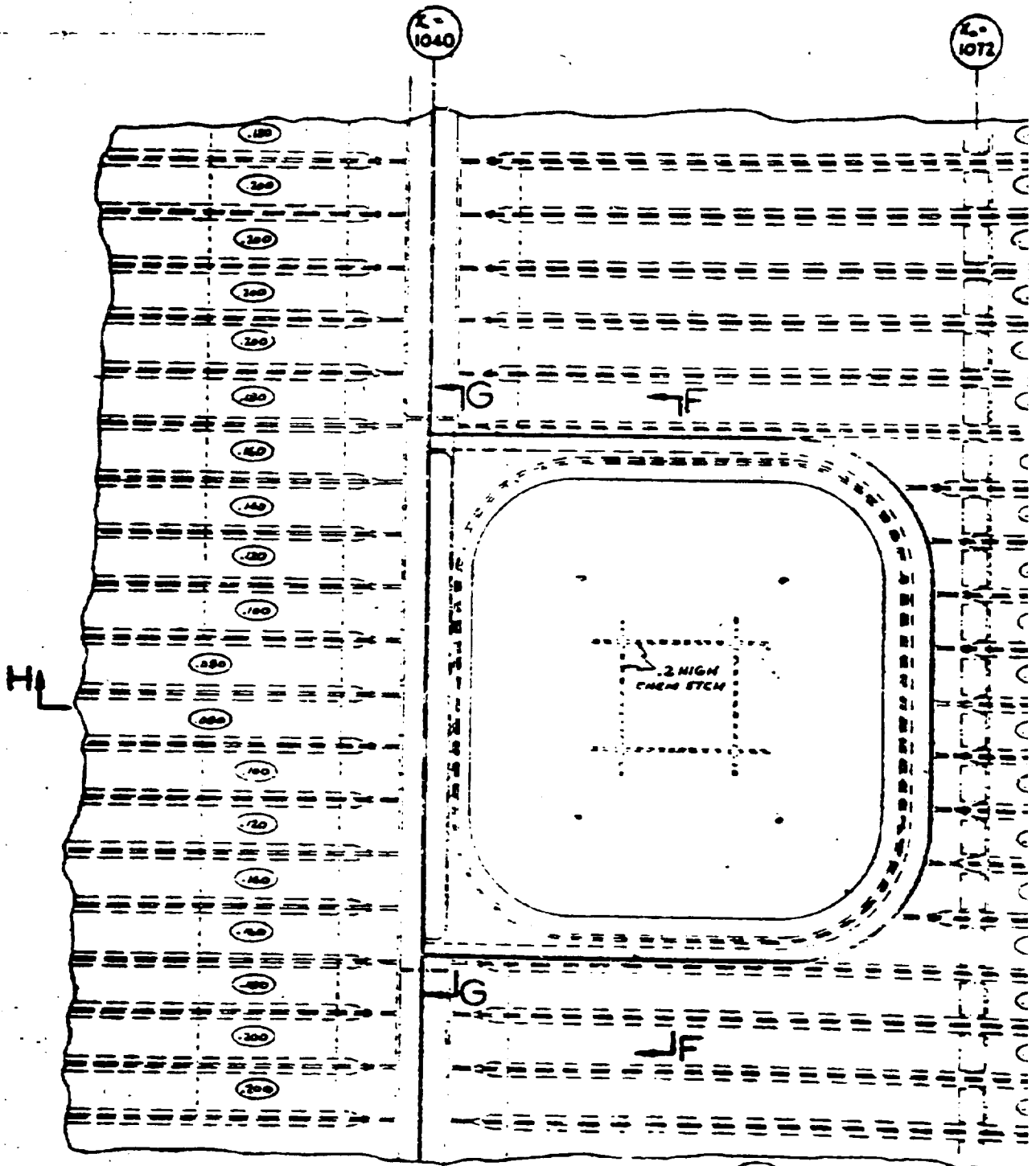

REPRODUCIBILITY OF THE ORIGINAL PAGE IS POOR

E 4-14

T FRAME

K
1040



H-H

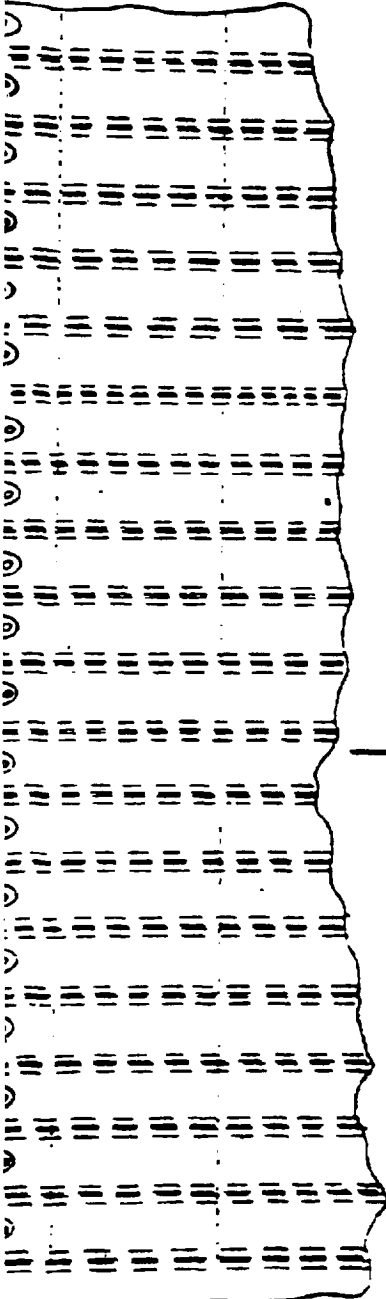

H

K-105



H



G

2-
1017

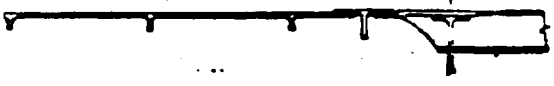

H-H



G-G



S-S

S-S

P-P

TYP VERTICAL SPLICE

REPRODUCIBILITY OF THE ORIGINAL PAGE IS POOR

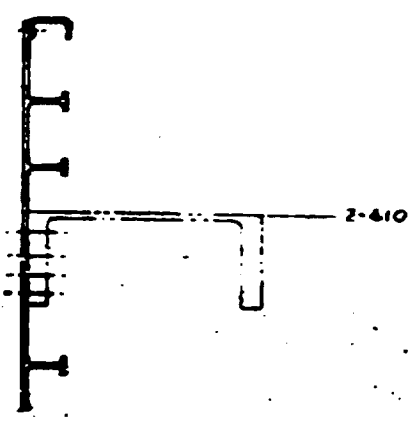

2-410

R-R

END OF PAGE

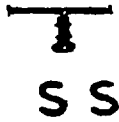
The image shows two technical drawing symbols. On the left, there are two parallel horizontal lines. On the right, there is a T-shaped symbol consisting of a horizontal line with a vertical stem extending downwards from its center. Below the T-shaped symbol are the letters 'S S' in a bold, sans-serif font.

SS

- 2-410

Figure 1.4.3. Mid Fuselage Side Panels

EXPLANATION

6

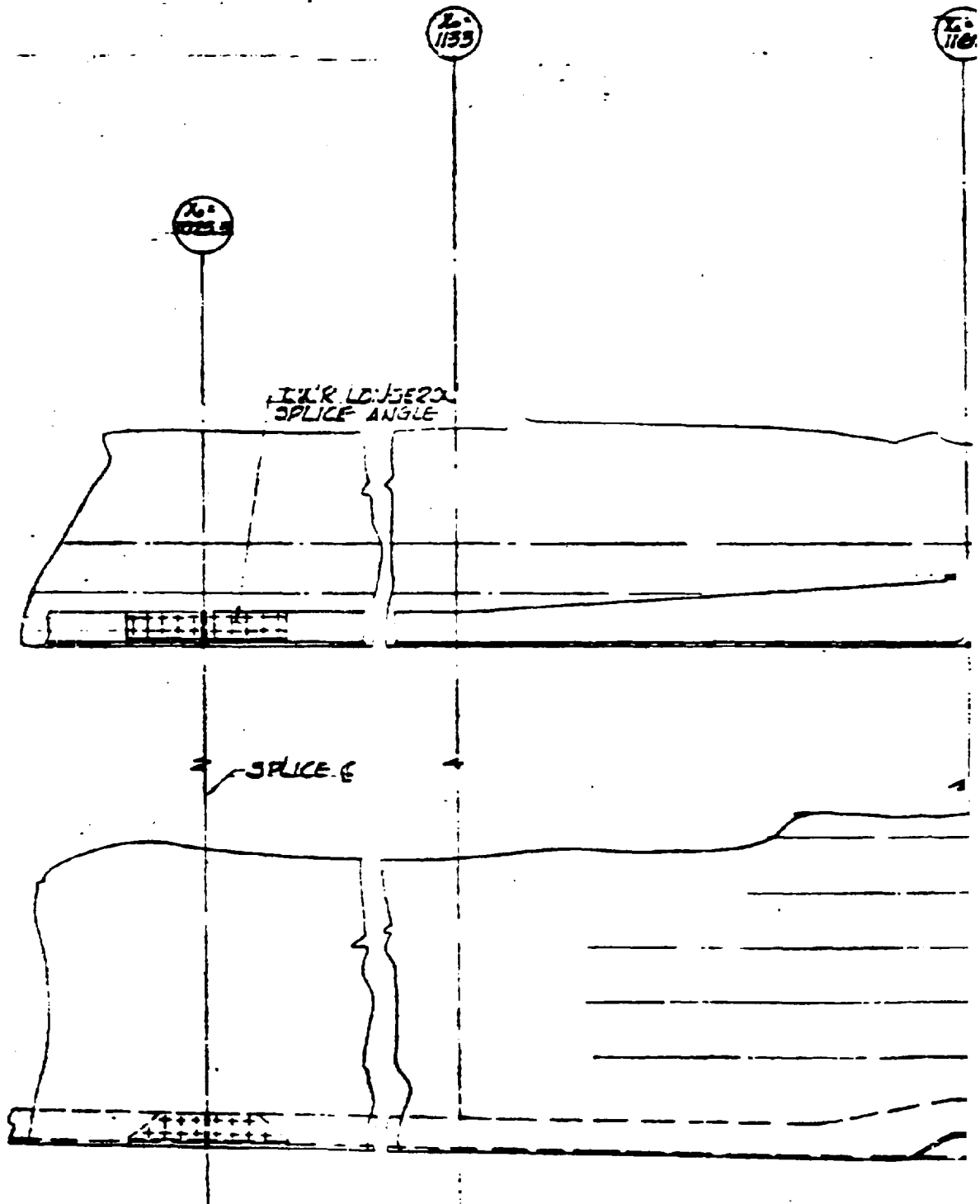

REPRODUCIBILITY OF THIS ORIGINAL PAGE IS POOR

10002 1133

Sta 1162

Sta 1191

Sta 1220

A-9

RISER 12

1 2 3 4 5 6 7 8

WING LWR
SURFACE PLATE
STRINGER ASS: REF

D

C

D

C

FRONT VIEW

2

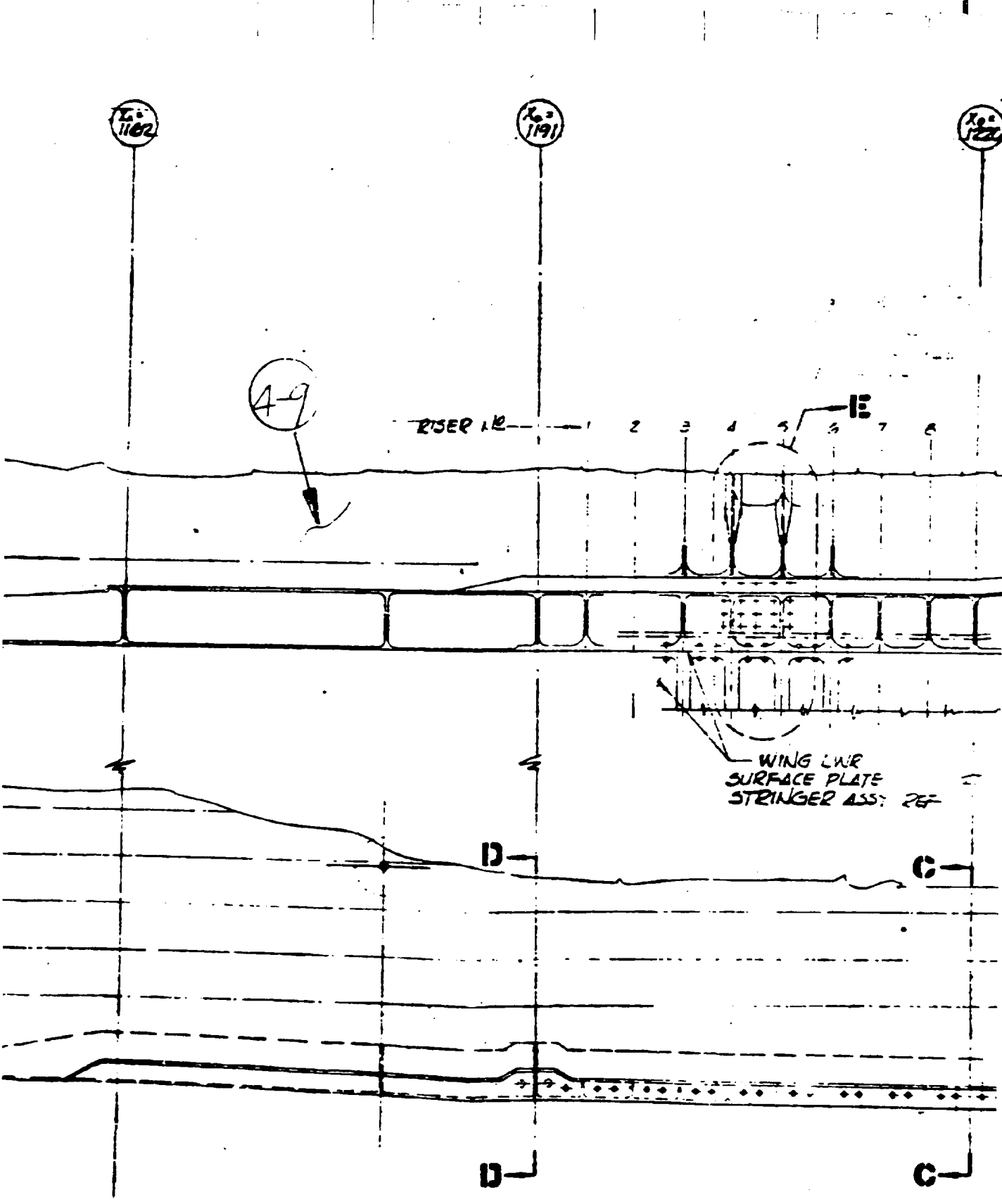

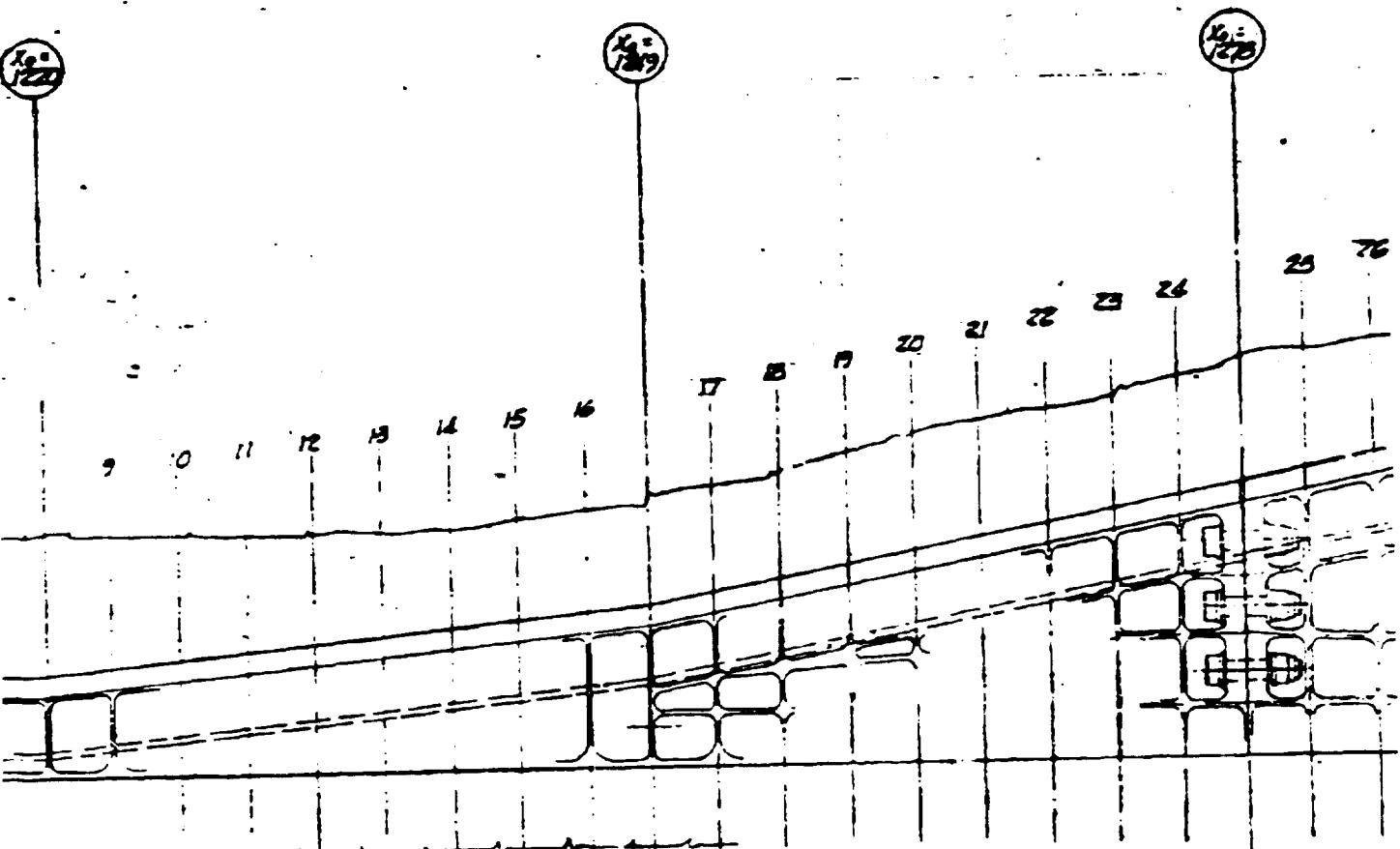

VIEW L'KING DN
AT LWR SURFACE
SCALE 1/4

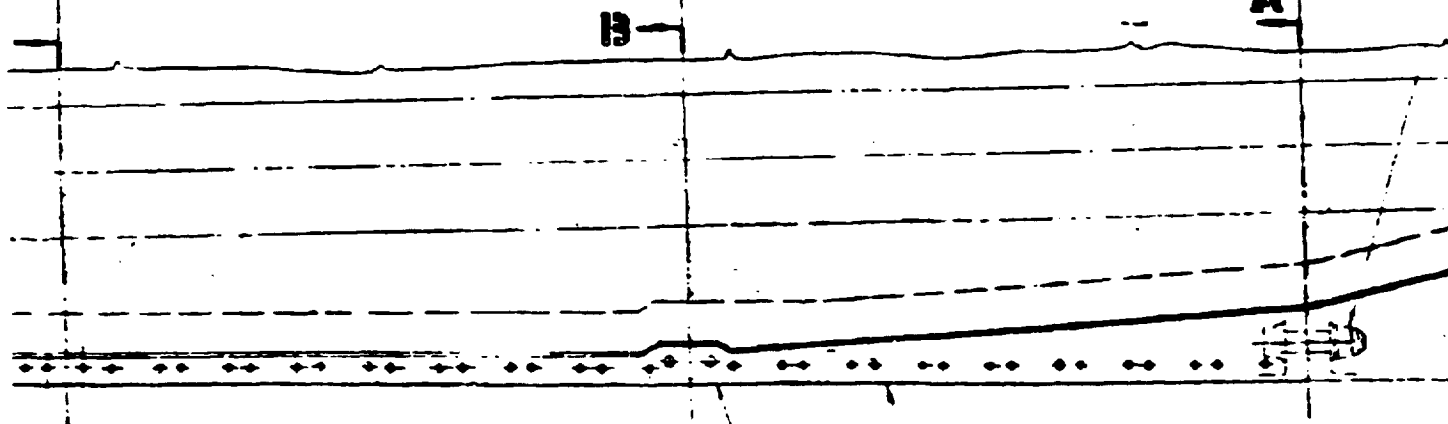

VIEW L'KING RSD
AT L-H SIDE SCALE 1/4

TOP REF.

- FUS INTERFAC
MOLD LINE @ Y-05
OUTER MOLD LINE

LWR REF PLANE

100
1307

27 28 29 30 31 32

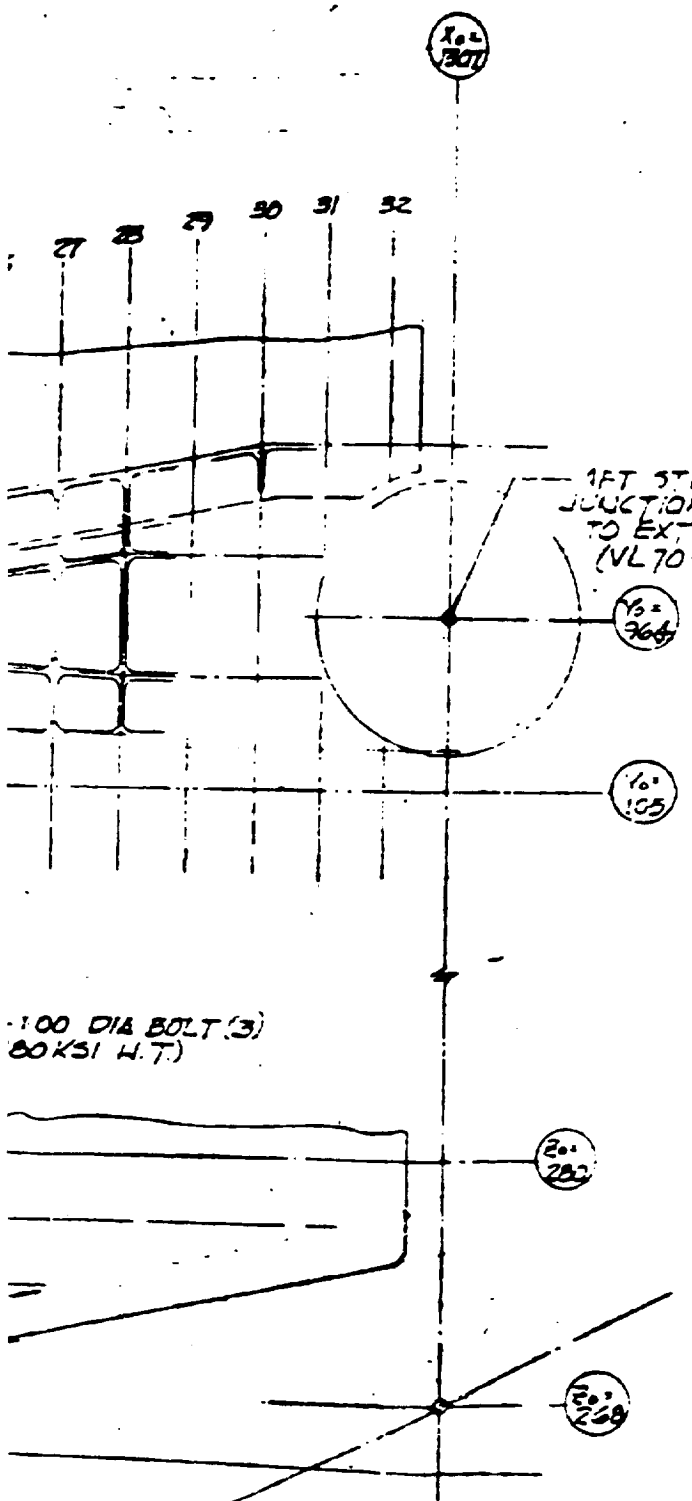

REPRODUCED FROM ORIGINAL PAGE IS 100%

INTERNAL
PAGE

Figure 1.4.4. Mid Fuselage Lower Aft Longeron

REPRODUCIBILITY OF THE ORIGINAL PAGE IS POOR

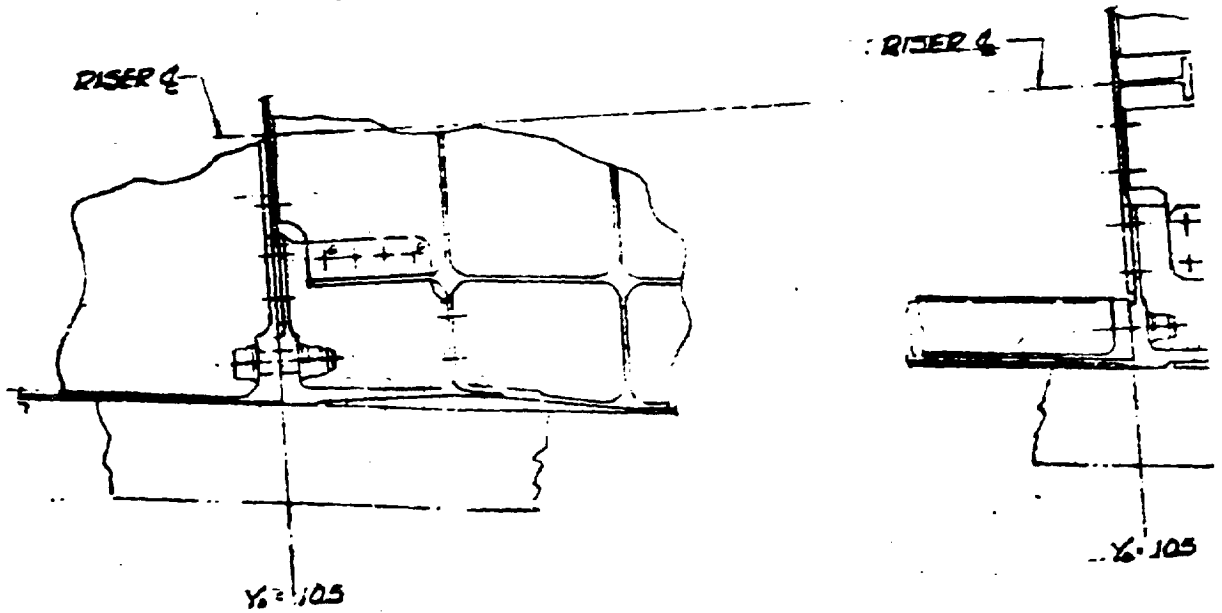

SECTION 13-13
SCALE 2
(X.0-112)

BOU FRAME

REPRODUCIBILITY OF THE ORIGINAL PAGE IS POOR

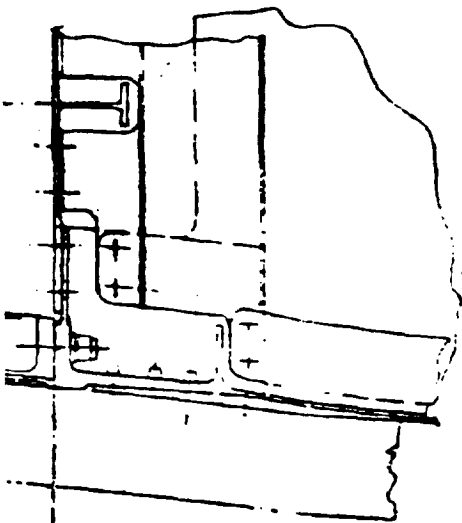

6-105

SECTION C-C
SCALE 1/2
(6-1220)

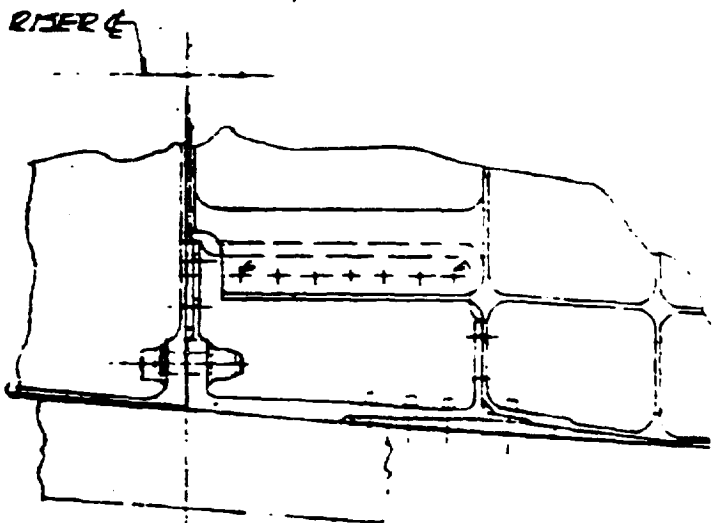

6-105

SECTION B-B
SCALE 1/2
(6-1249)

OUT FRAME

2

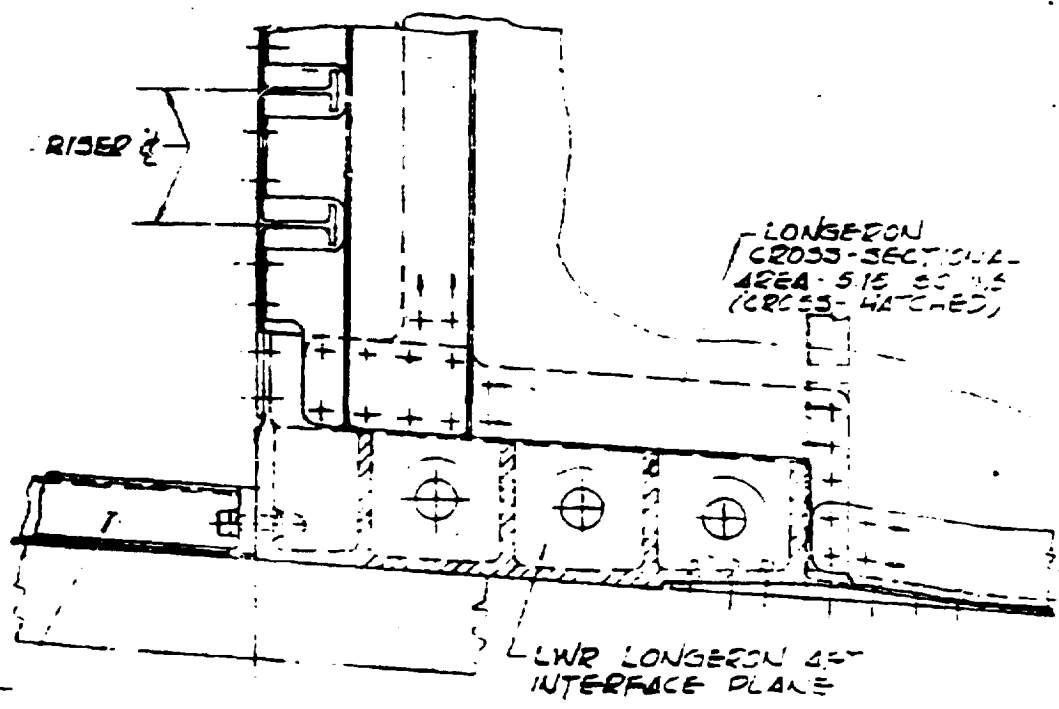

RISE

LONGERON
CROSS-SECTIONAL
AREA - 515 SQ IN
(CROSS-HATCHED)

LWR LONGERON 25"
INTERFACE PLANE

WING REF. -

Y6-105

SECTION A - A
SCALE 1/2
Y6-1270

OUT FRAME
3

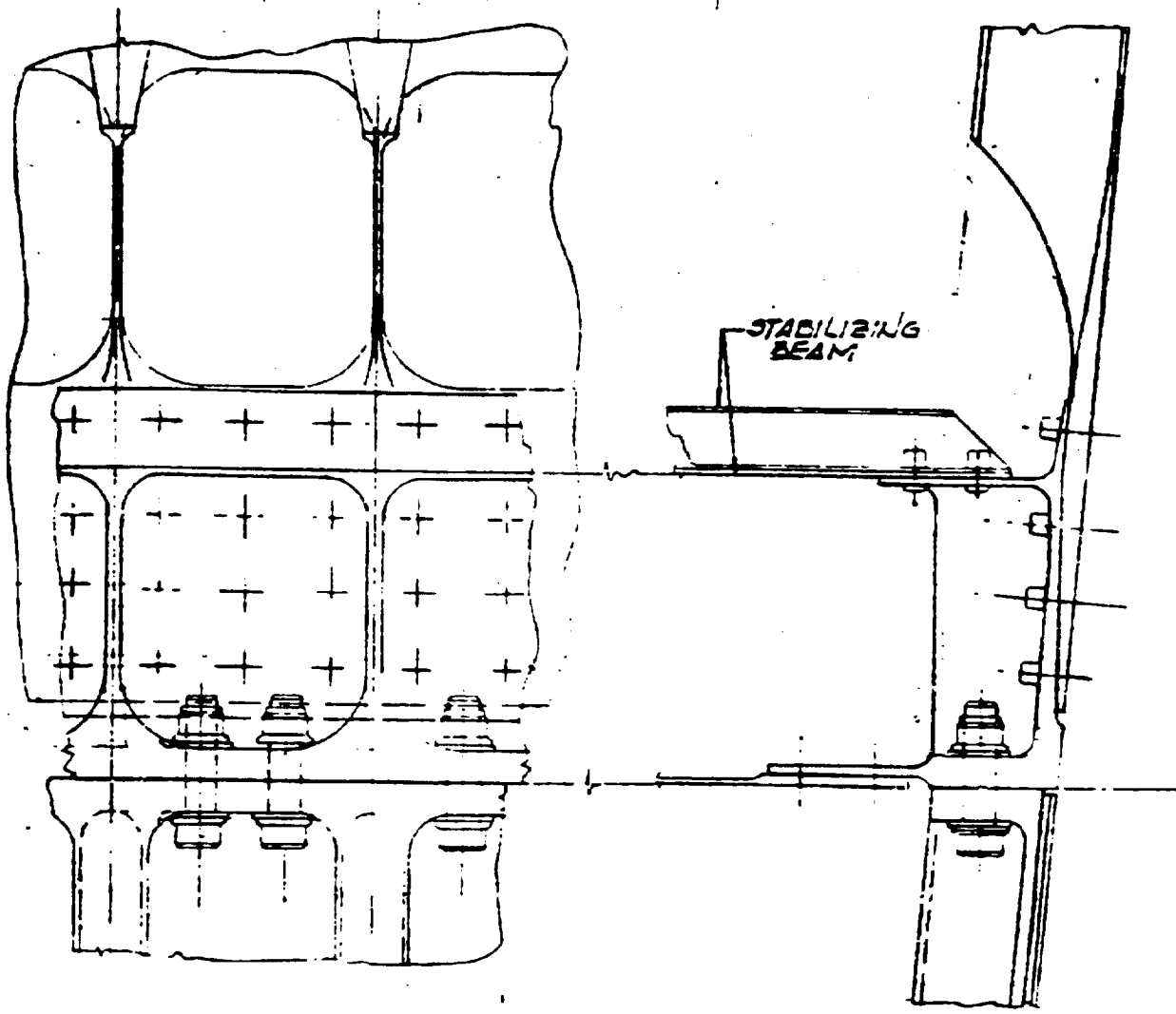

VIEW E
SCALE 1/1

42
45
57

OUT FRAME

41

Figure 1.4.5. Mid Fuselage Lower Air Longeron

REPRODUCIBILITY OF THE ORIGINAL PAGE IS POOR

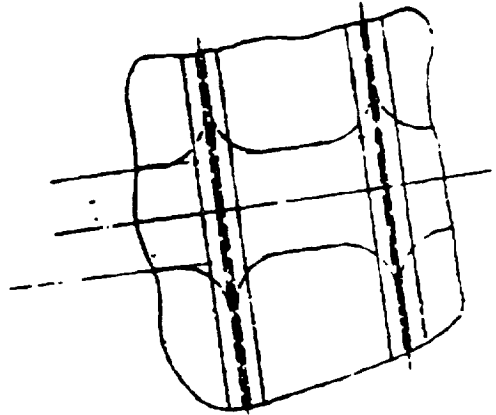

SECTION G-G
SCALE 1/1



SECTION D-D
SCALE 1/1

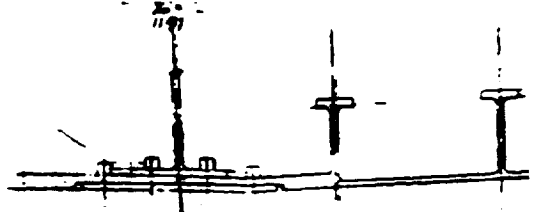

SECTION B-B
SCALE 1/1

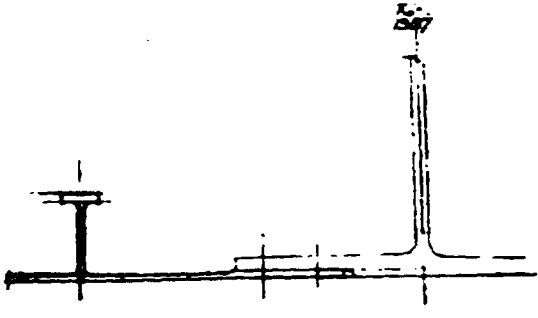

SECTION F-F
SCALE 1/1

12012

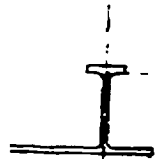

-B

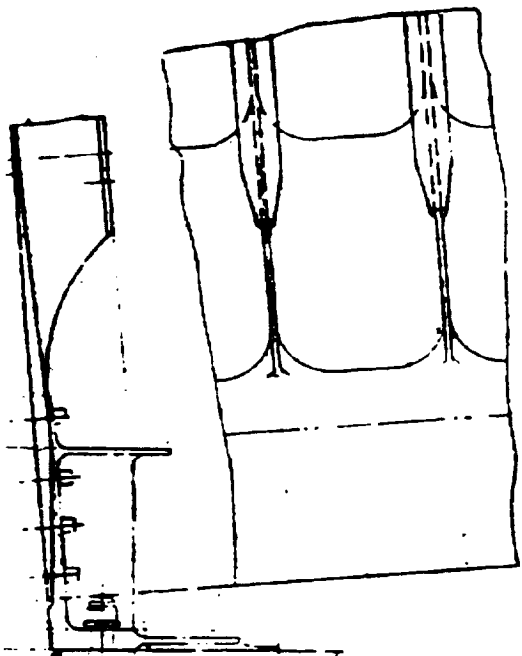

-RHS SIDE INTER-FACE MOLD LINE

SECTION C-C
SCALE 1/1

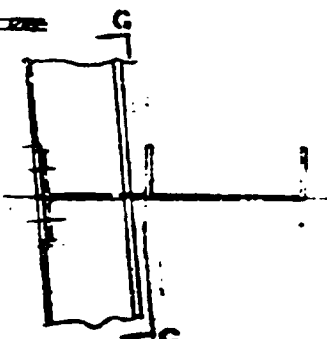

SECTION A-A
SCALE 1/1
TOP AT X=0.00, Y= 8.3
X=24.5, Y=39.30 Y= 52.25
X=66.66, Y= 78.75

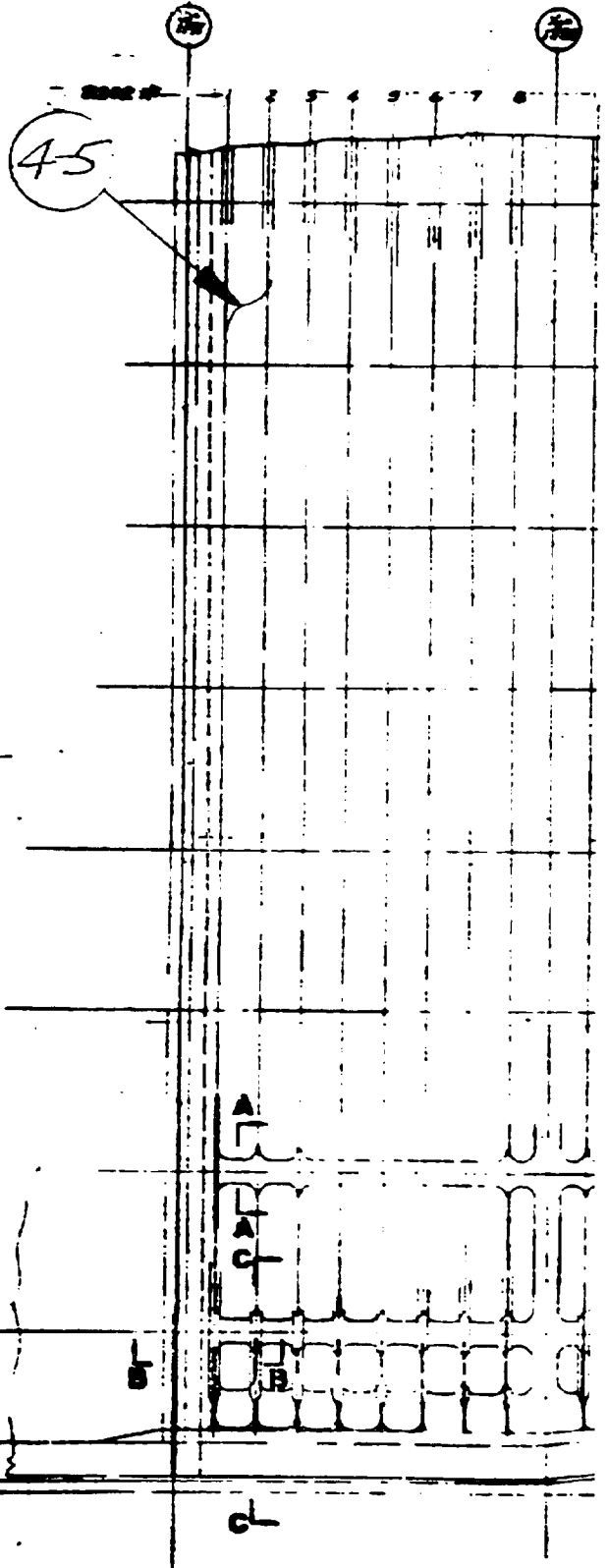

45

A

L

A

C

B

B

C

02 FRANK

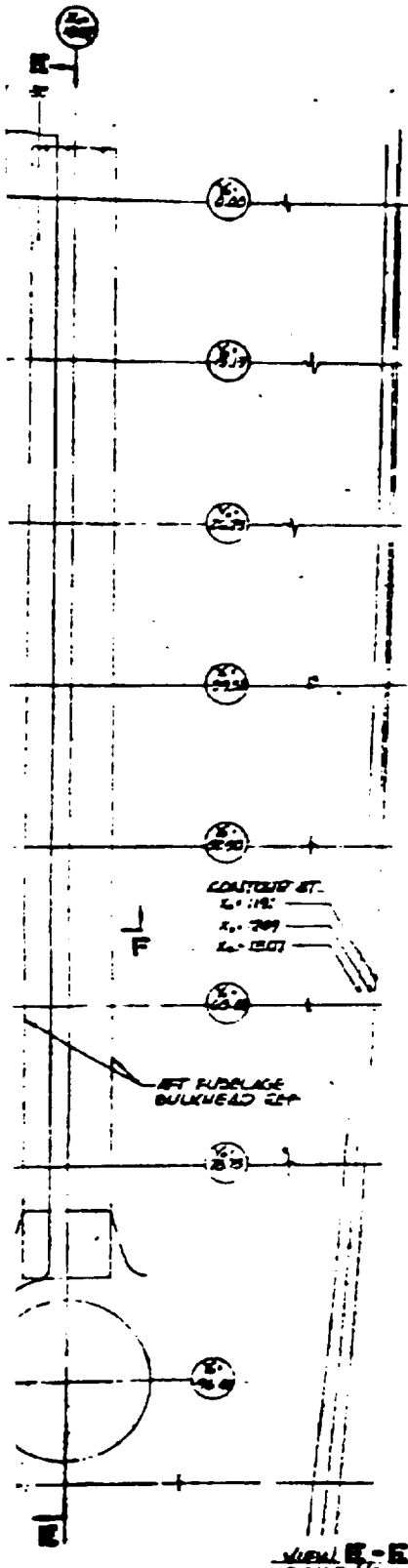

CONTOUR ST.
 2. 118
 2. 209
 2. 1207

F

AFT FUSelage
 BULKHEAD REF

VIEW E-E

REPRODUCIBILITY OF THE
 ORIGINAL PAGE IS POOR

NOTES

1. MACHINED LANGE WILL EXIST AT EACH FRAME, SKIN STRENGTHENED AND BULKHEAD.
2. SKIN THICKNESSES VARY ON EACH INDIVIDUAL SKIN PANEL.
3. ALL SKINS ARE COMPOUND CONTOURED.
4. ALL RIBS ARE 750 AND ARE SPACED 9.25 INCHES APART.

1.4.6. Mid Fuselage Lower Aft Skin Panels

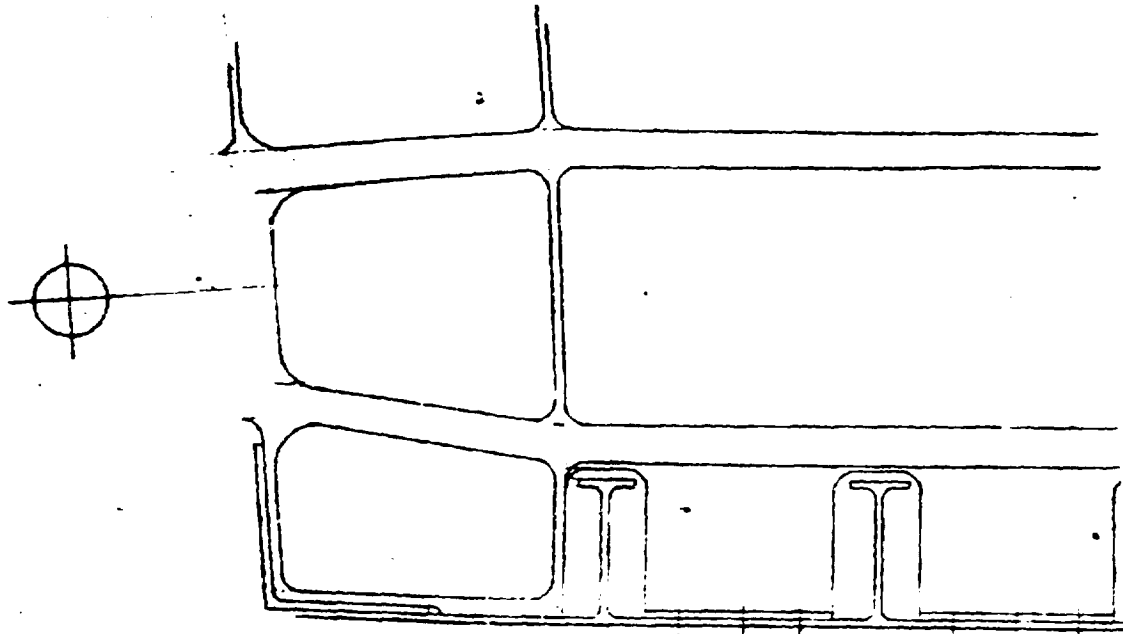

DETAIL A-Q

REPRODUCIBILITY OF THE ORIGINAL PAGE IS POOR

FOLLOUT FRAME

620

REPRODUCIBILITY OF THE
ORIGINAL PAGE IS POOR.

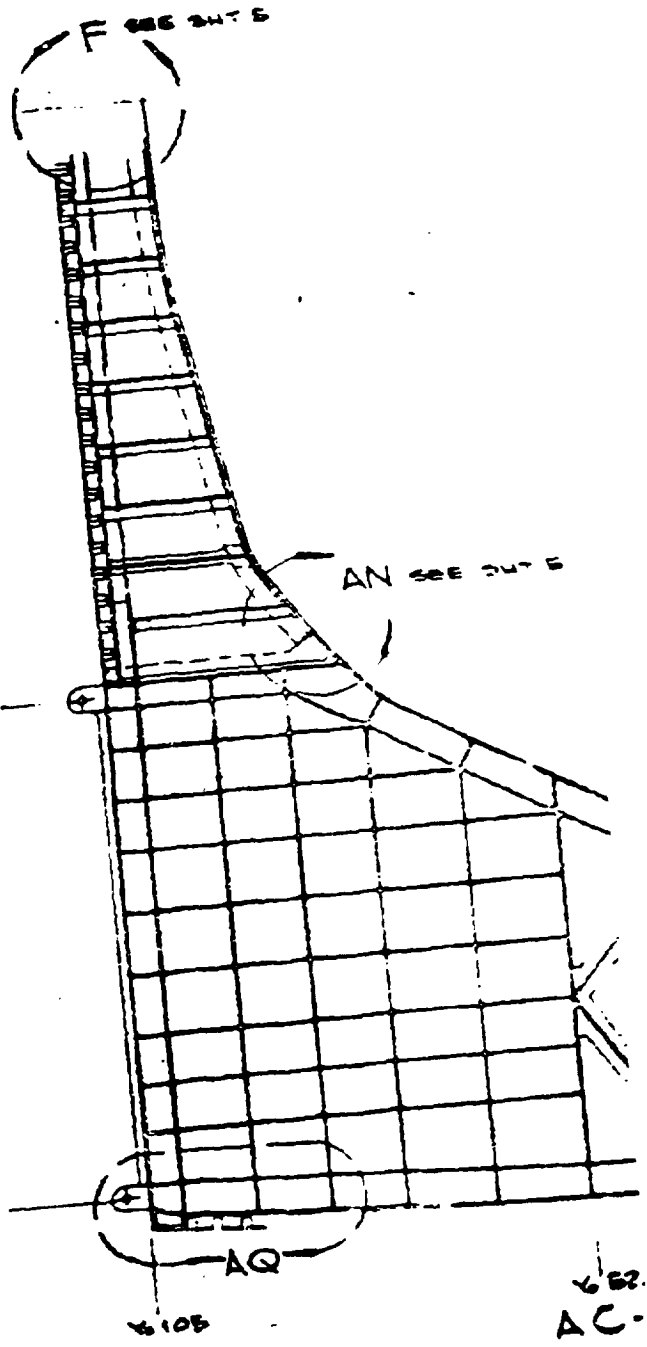
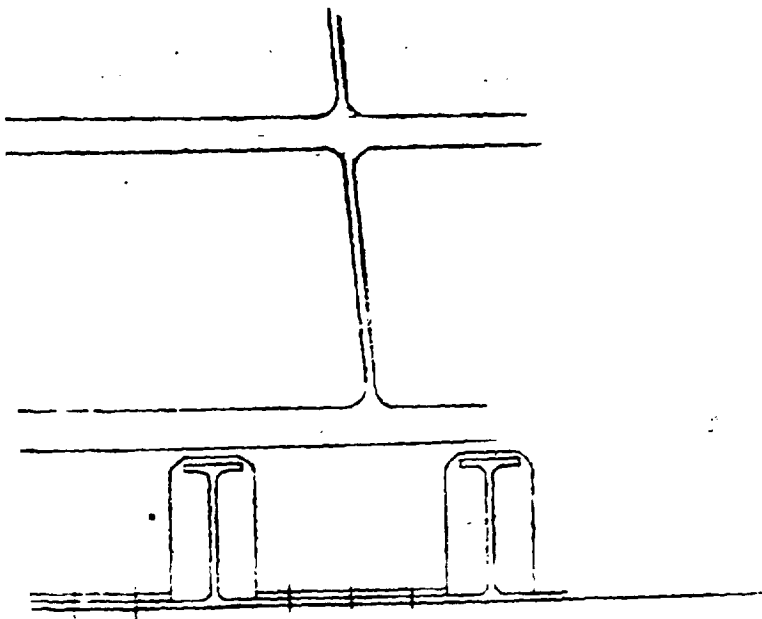

FOLDOUT FRAME

2

SEE OUT 5

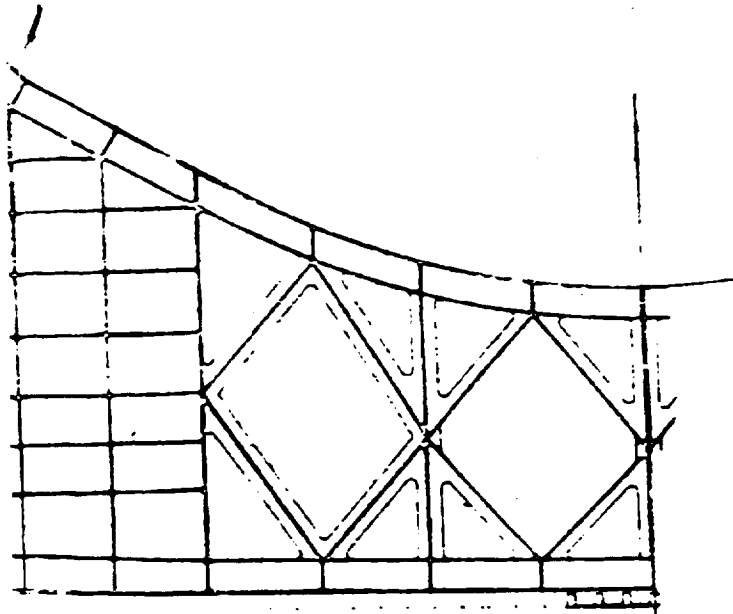

AC-AC

WALDOUF FRAME

3

8.00

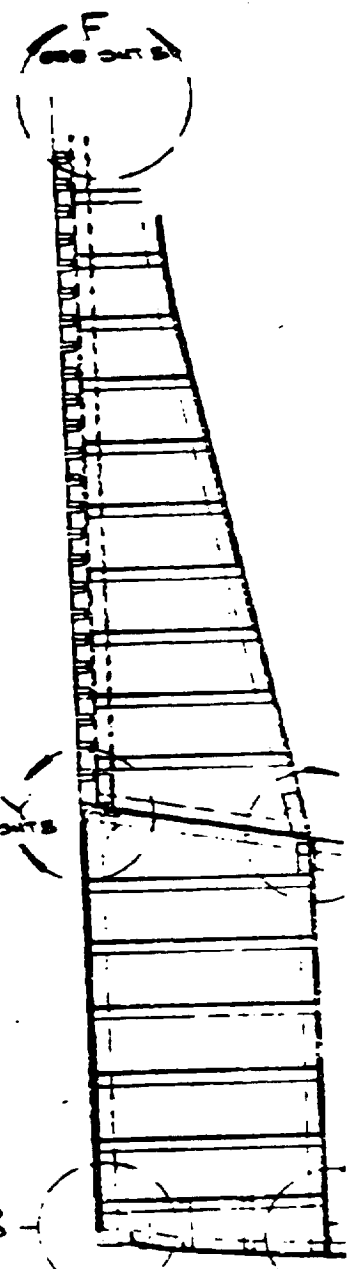

SEE OUT 5

AC FOR X-1220
AS X-1210
SEE OUT 5

6.08

6.7

REPRODUCIBILITY OF THE ORIGINAL PAGE IS POOR

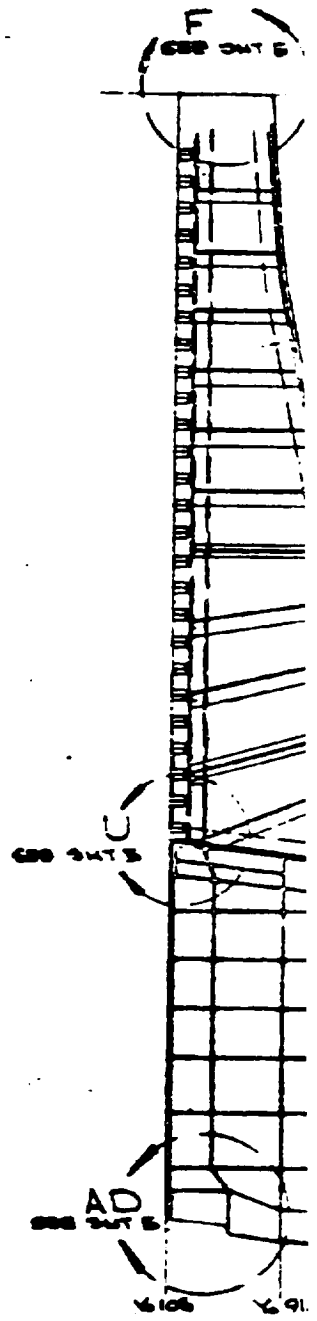
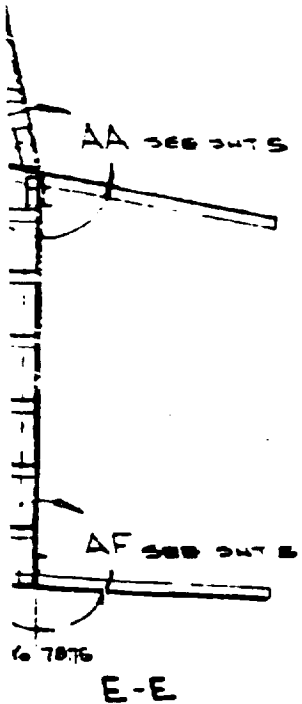

FRAME

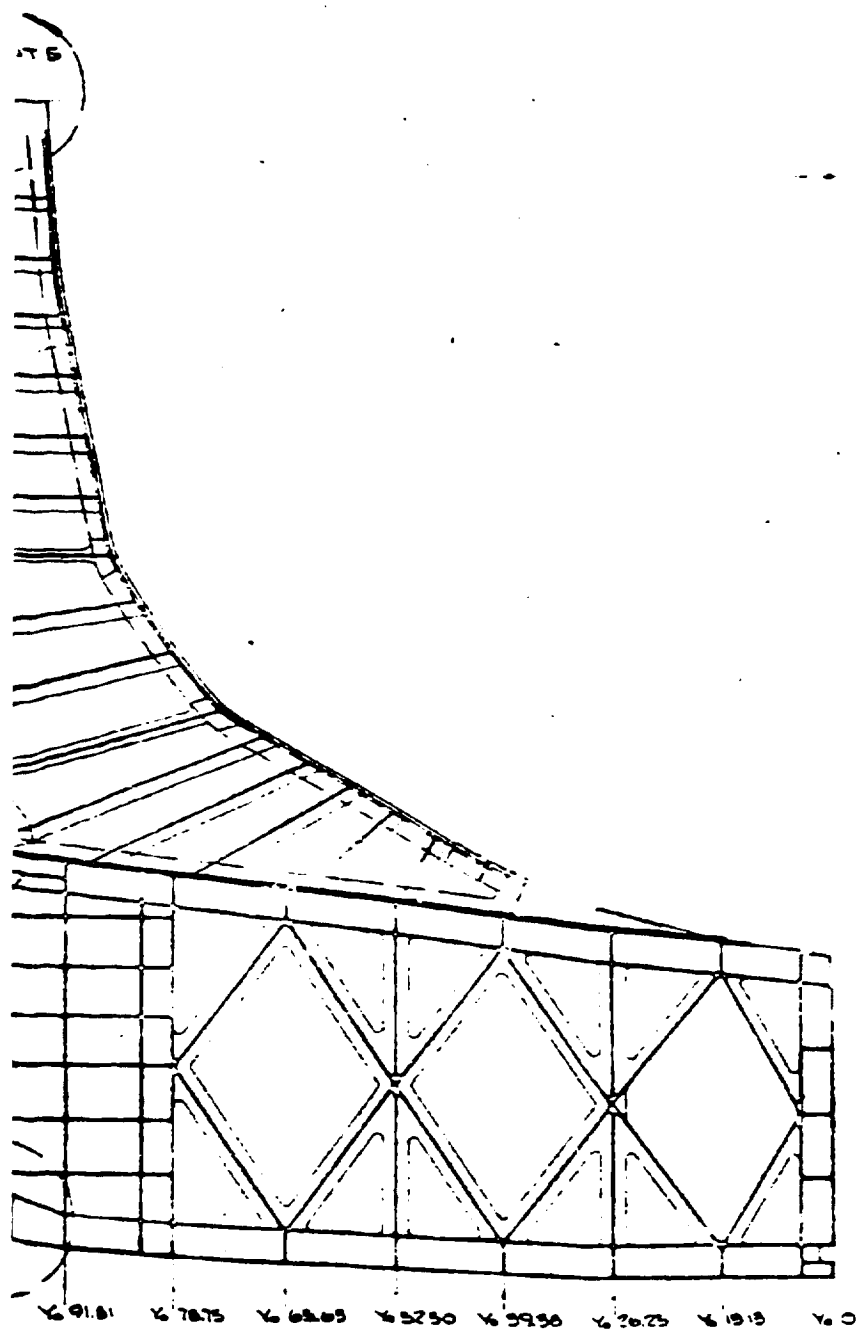

D-D

OUT FRAME

5

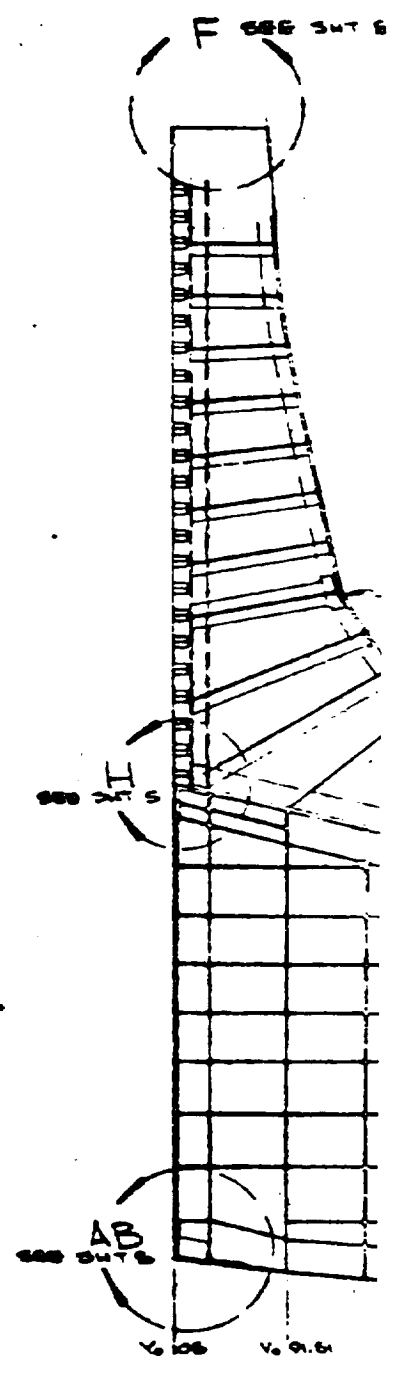

AB

SEE INT. AC

C

E

D

E

SEE INT. B

KICK FITTINGS (2)

SEE INT. S

4-10

0.91.01 1.78.3 1.65.05 1.57.90 1.50.75 1.26.75 1.5.5 1.0

C-C

NOT DRAWN

6

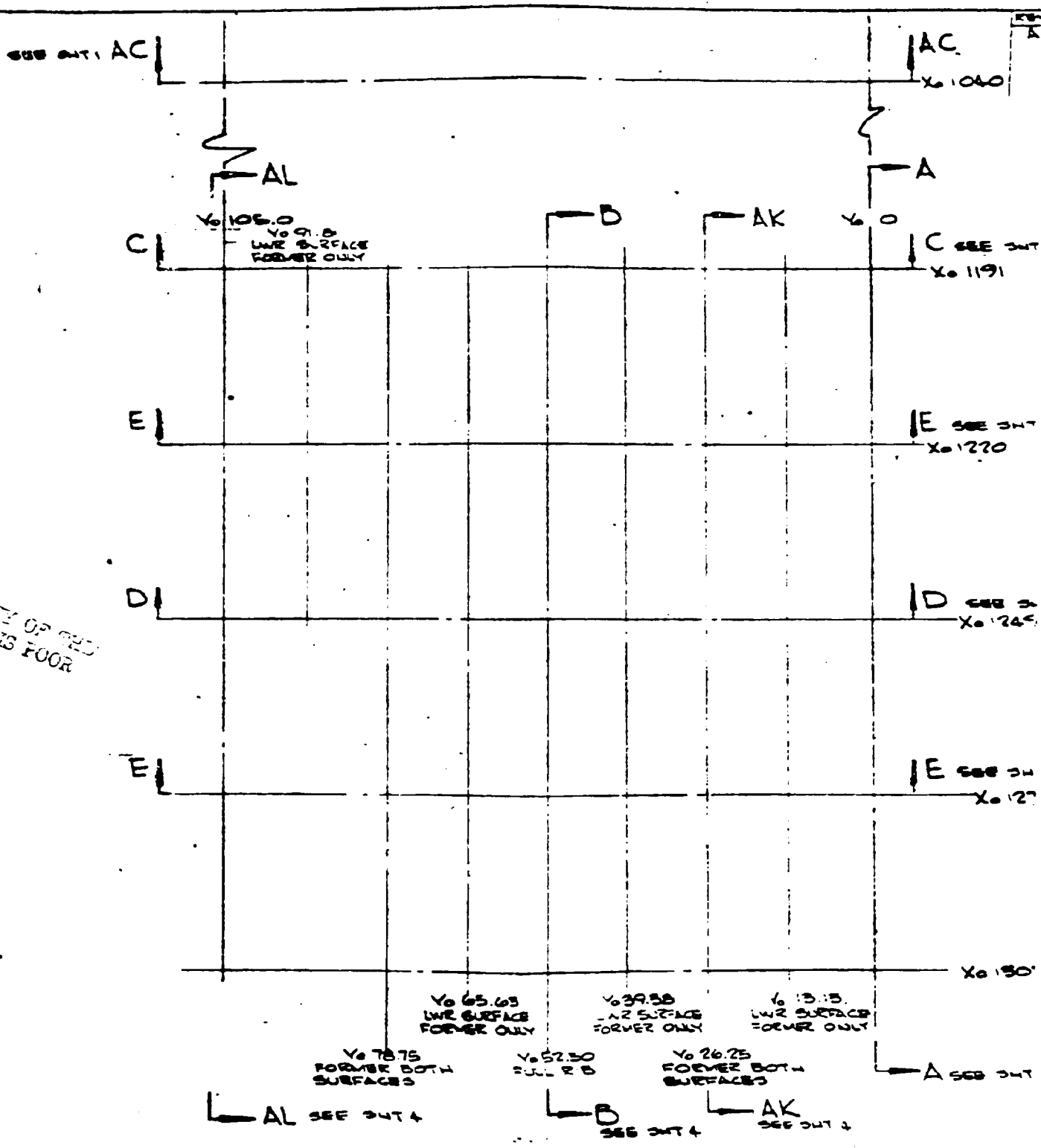

EXTENTS OF GRID
AGE IS FOUR

Figure 1.4.7. Mid Fuselage Wing Carry-Through

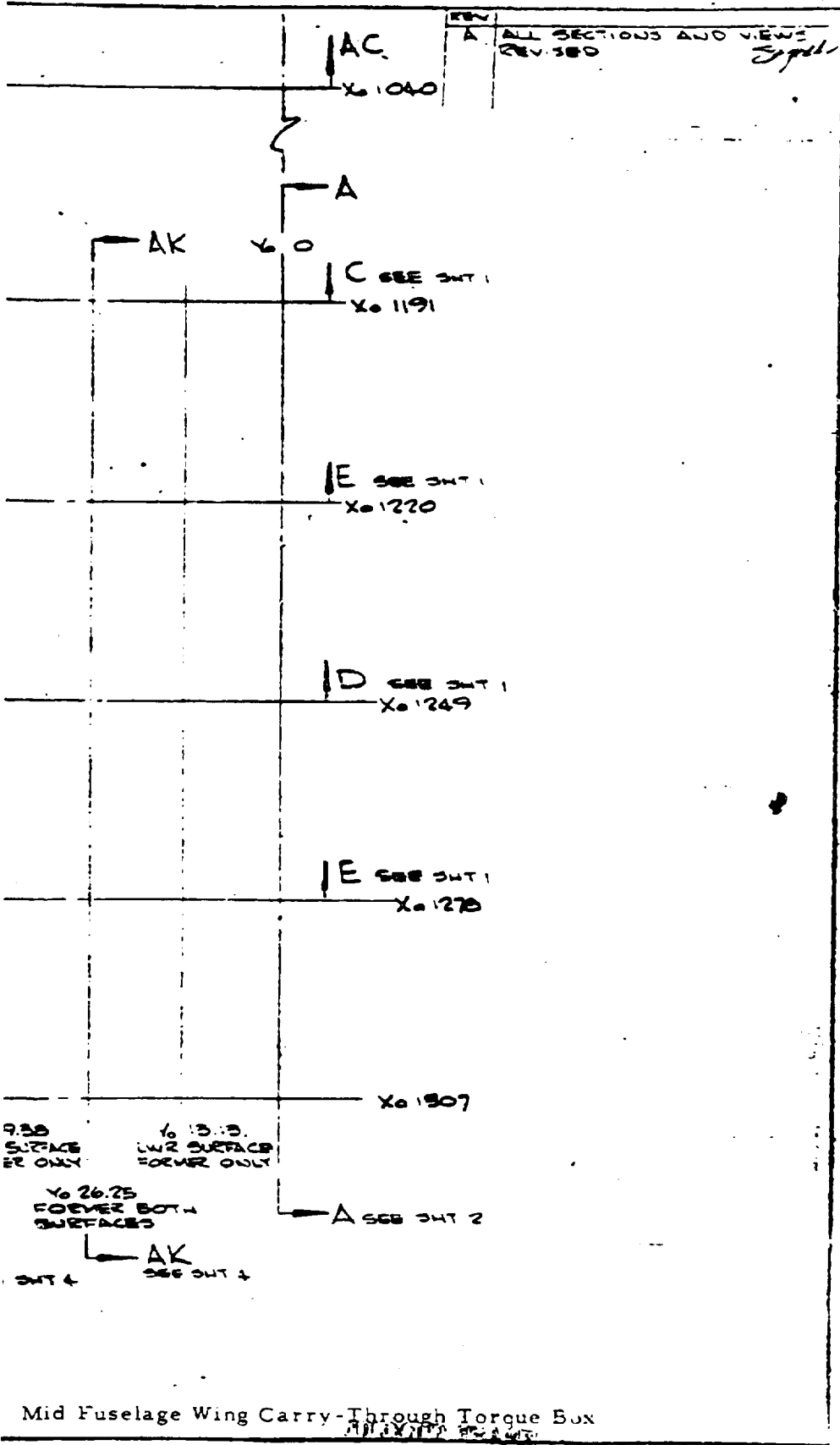

λ_o = 370

λ_o = 636

λ_o = 693

λ_o = 750

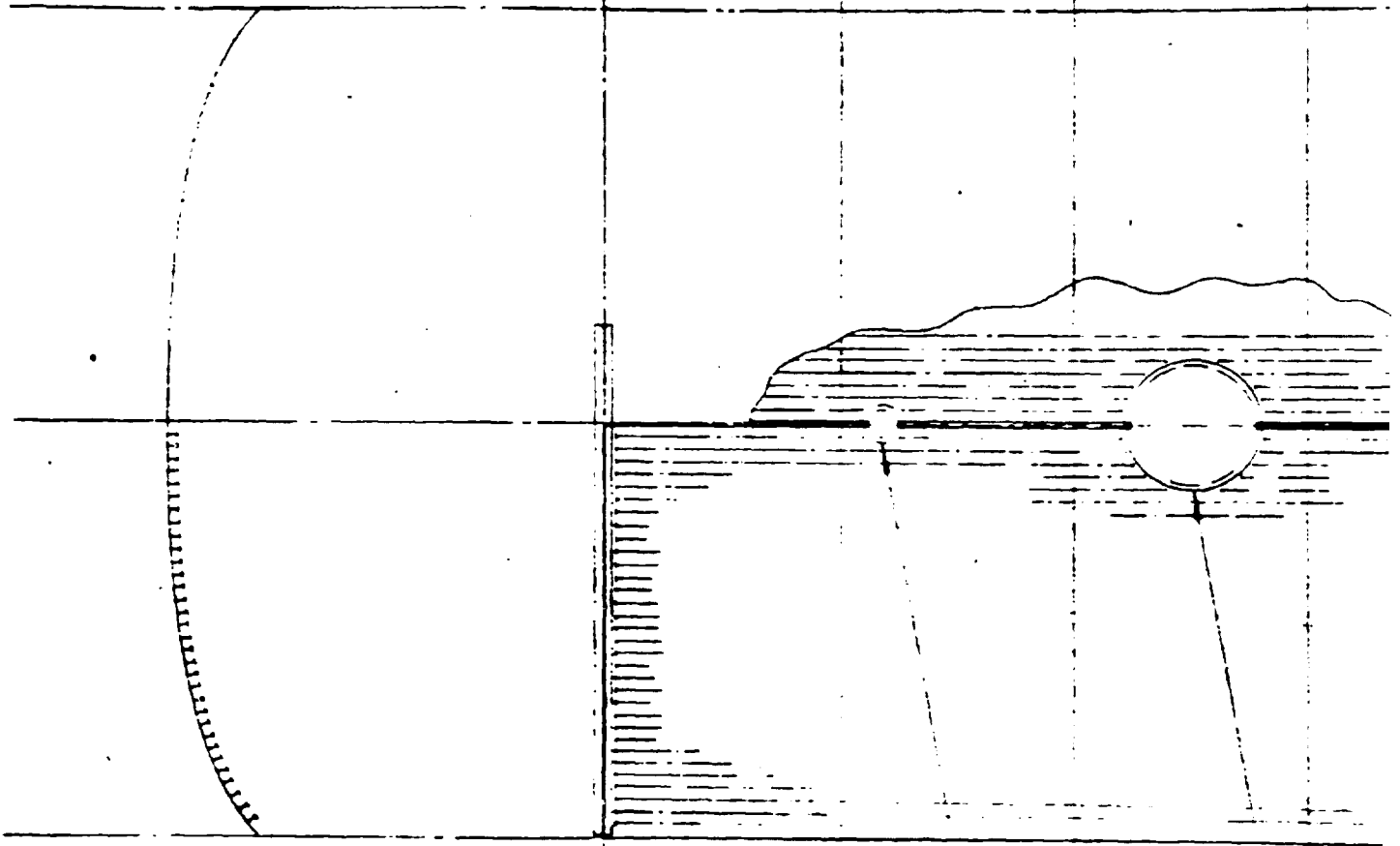

AVIONIC'S
L BAND
ANTENNA

VME

REPRODUCIBILITY OF THE
ORIGINAL PAGE IS POOR

OUT FRAME

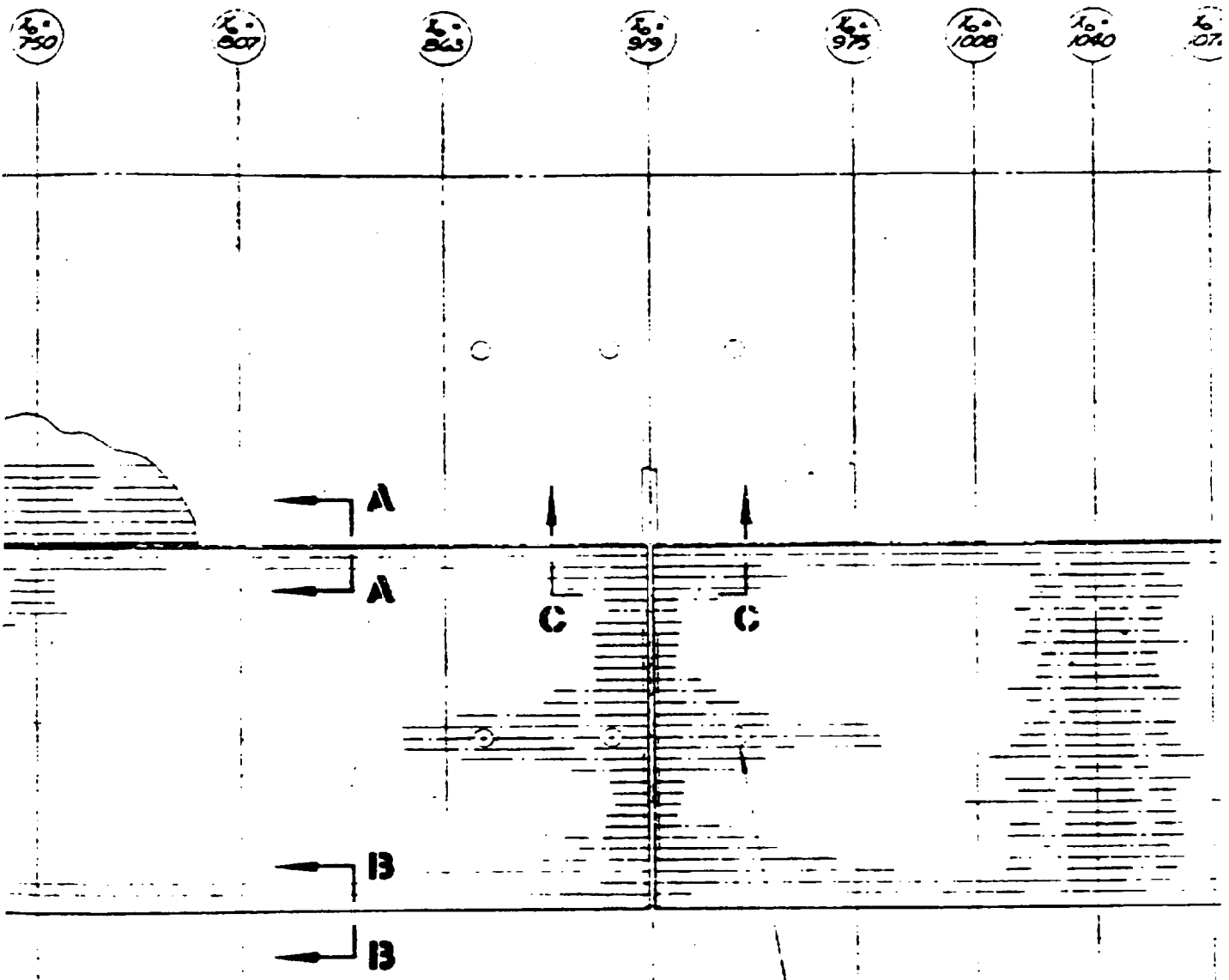

1/4 WAVE ANTENNA

2' BAND ANTENNA
6 PLACES

PLAN VIEW
SCALE 1/80

OUT FRAME

10° 1072

10° 1148

10° 1133

10° 1162

10° 1191

10° 1307

10° 105

10° 00

SYM

10° 105

TOZ 1024 REF LOWER AFT SKIN PANEL

SEE TOZ 1024 SECTION B-B

OUT FRAME

3

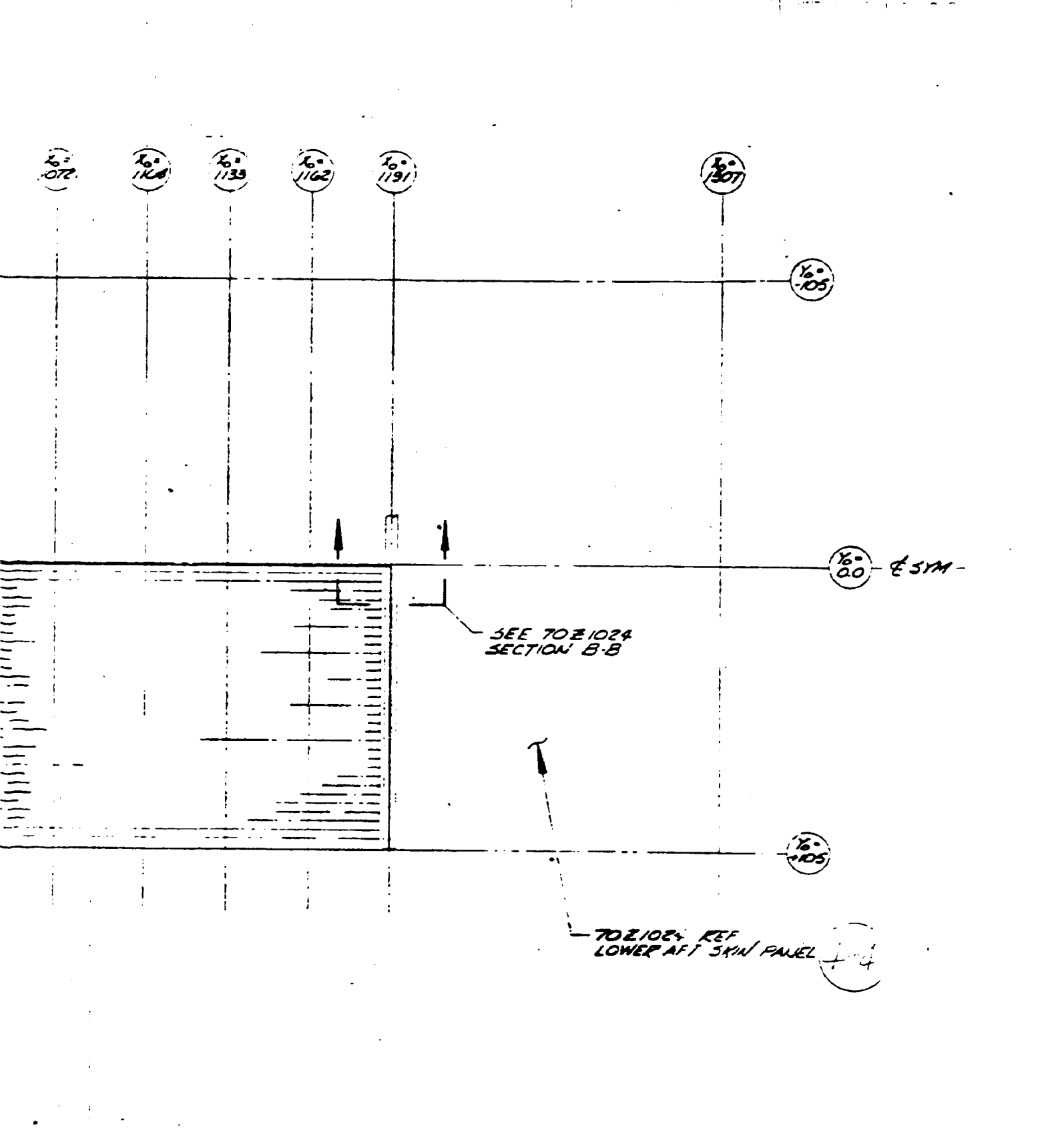

10°
105

10°
00 & SYM -

NOTES-

1. MACHINED LANDS WILL EXIST AT EACH FRAME, SKIN STIFFENER AND BULK-HEAD
2. SKIN THICKNESSES VARY ON EACH INDIVIDUAL SKIN PANEL
3. ALL SKINS ARE COMPOUND CONTOURED
4. ALL STIFFENERS ARE TEE AND ARE SPACED 3.25 INCHES APART

10°
105

REL + 4

FOLDOUT FRAME

Figure 1.4.8. Mid Fuselage Lower Skin Panels

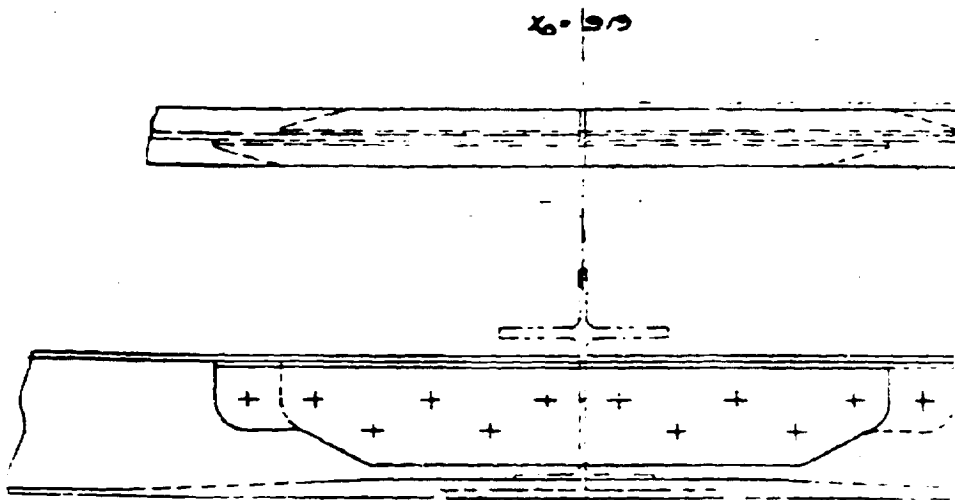
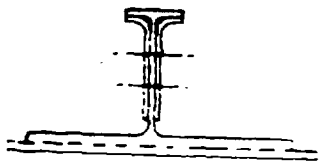

SECTION C - C
SCALE 1/1

REPRODUCIBILITY OF THE
ORIGINAL PAGE IS POOR

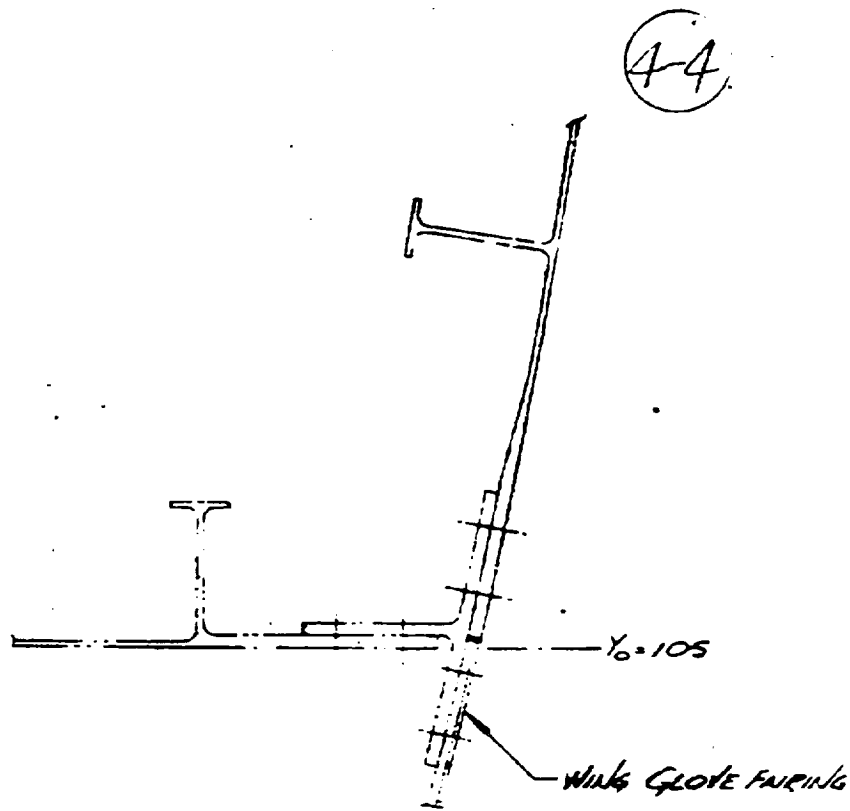
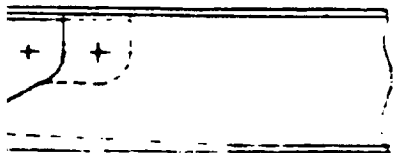
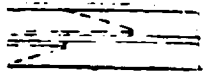

SECTION 13 - 13
SCALE 1/1

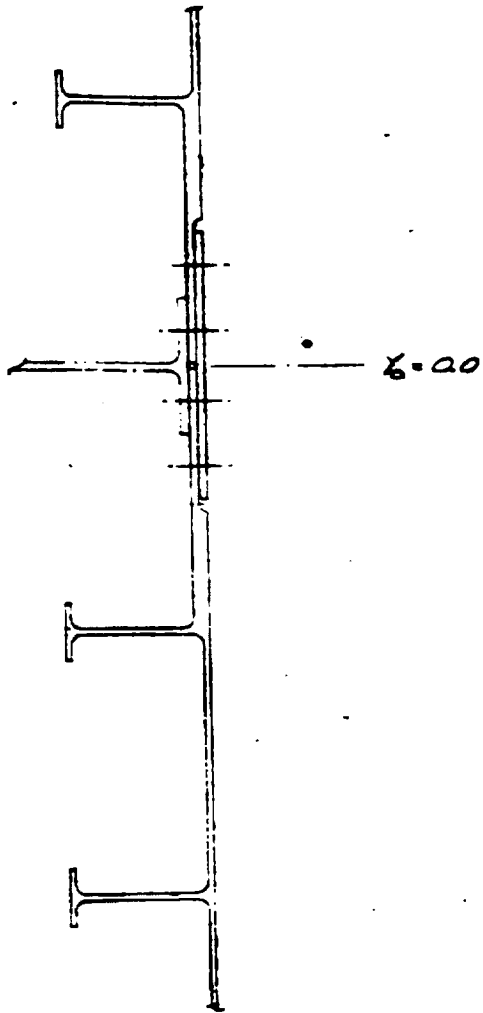

SECTION A-A
SCALE 1/1

Figure 1.4.9. Mid Fuselage Lower Skin Panels

DO NOT WRITE

3

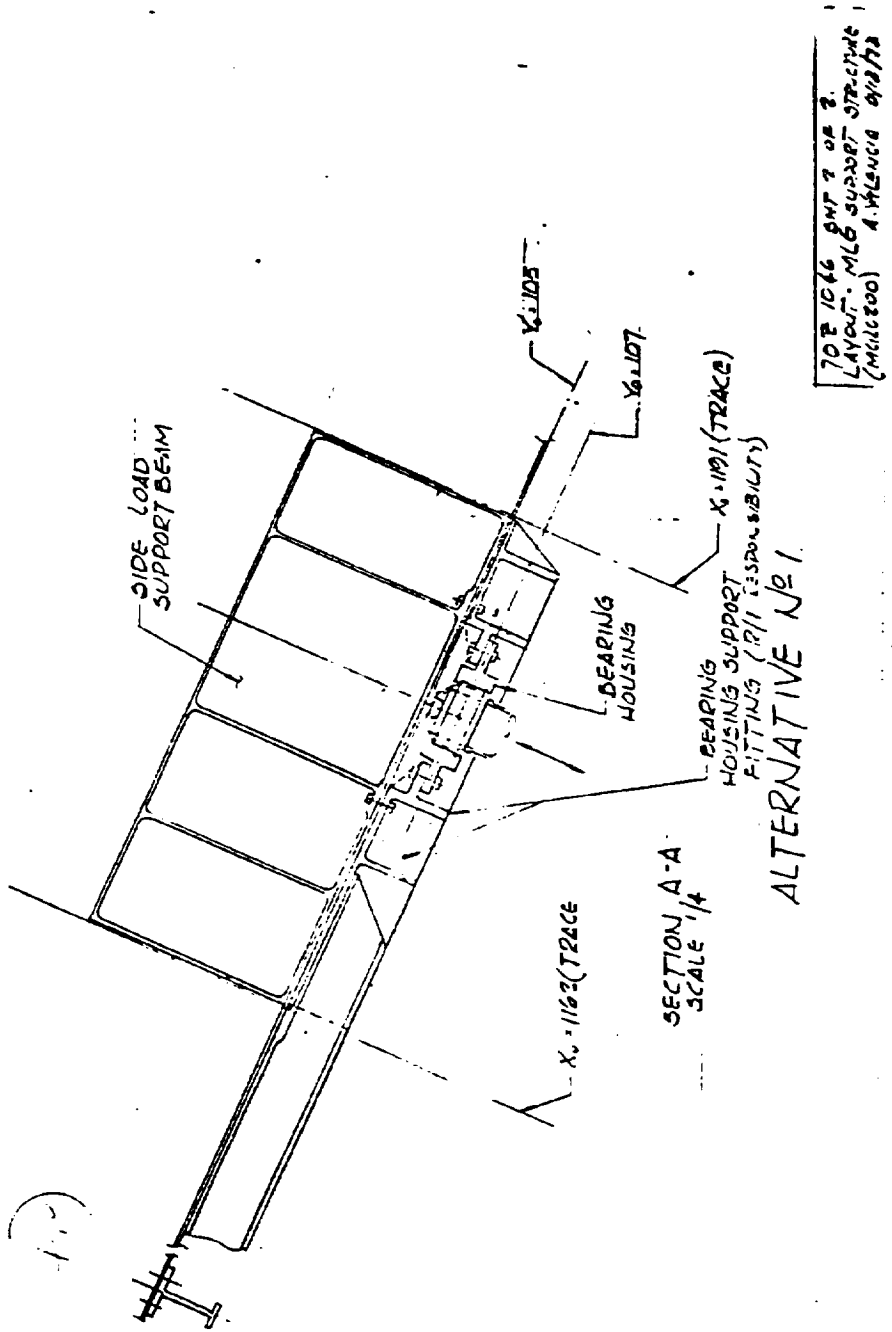
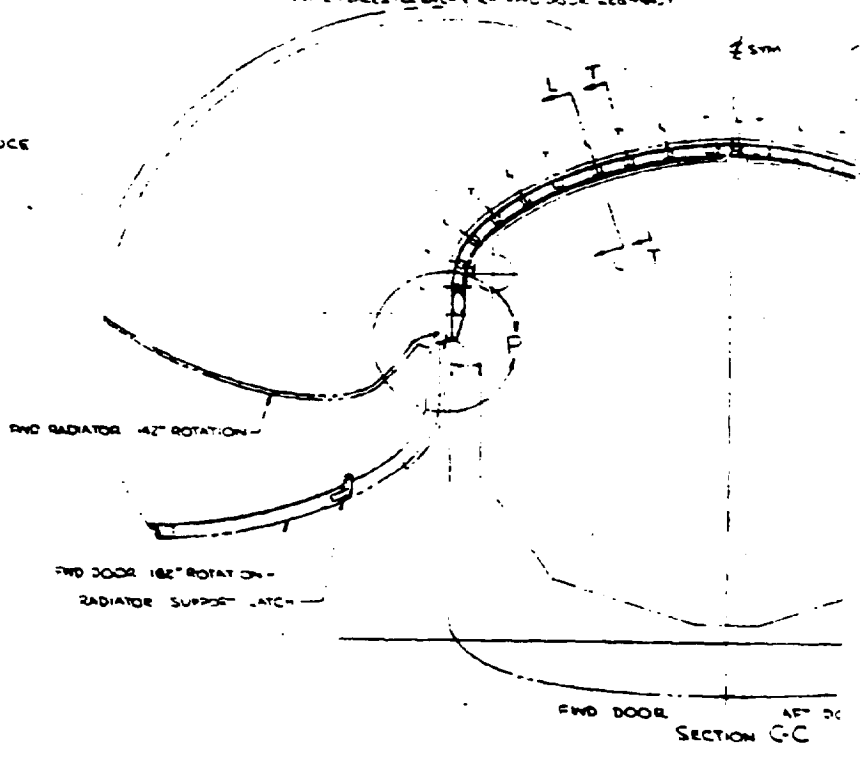
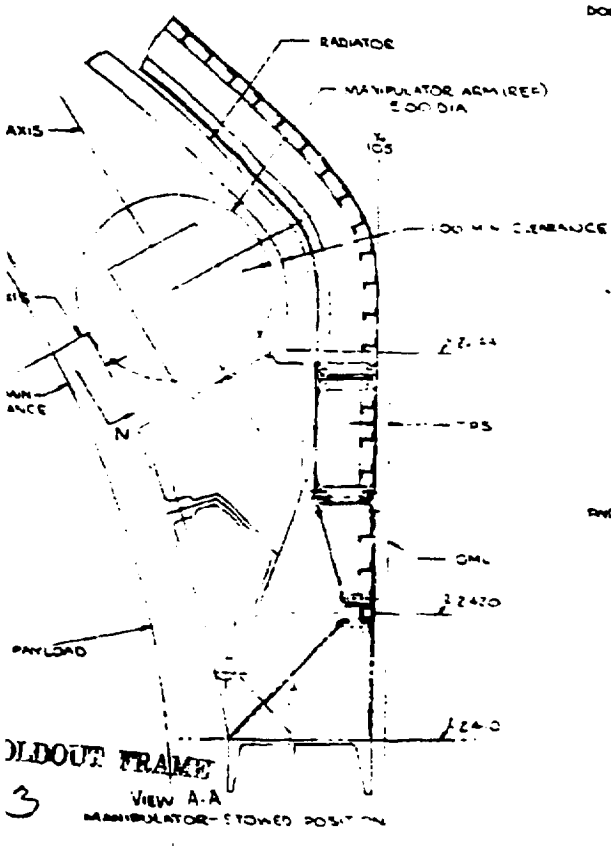
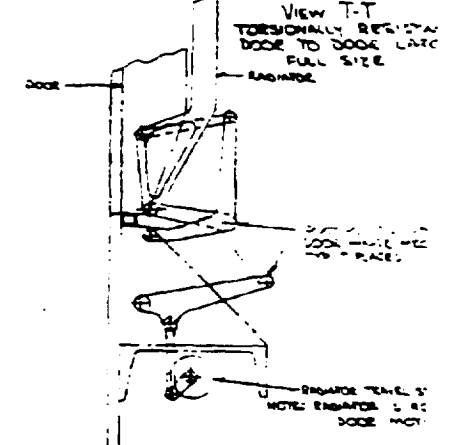
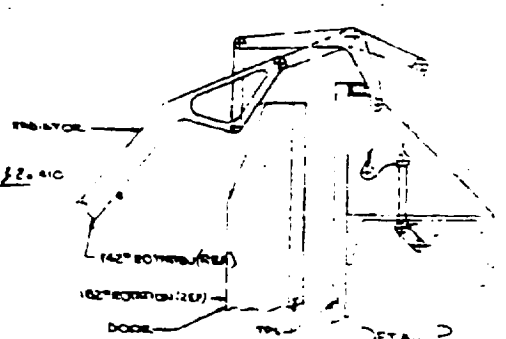
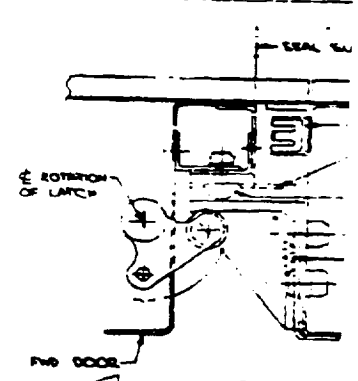
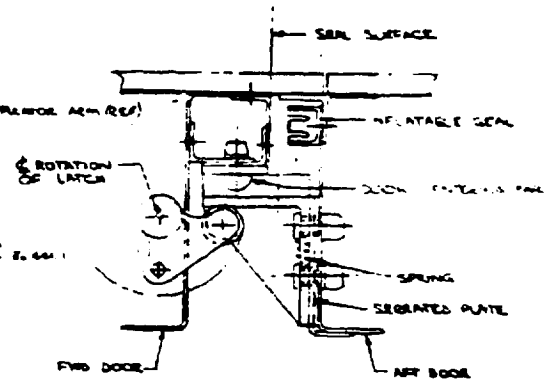
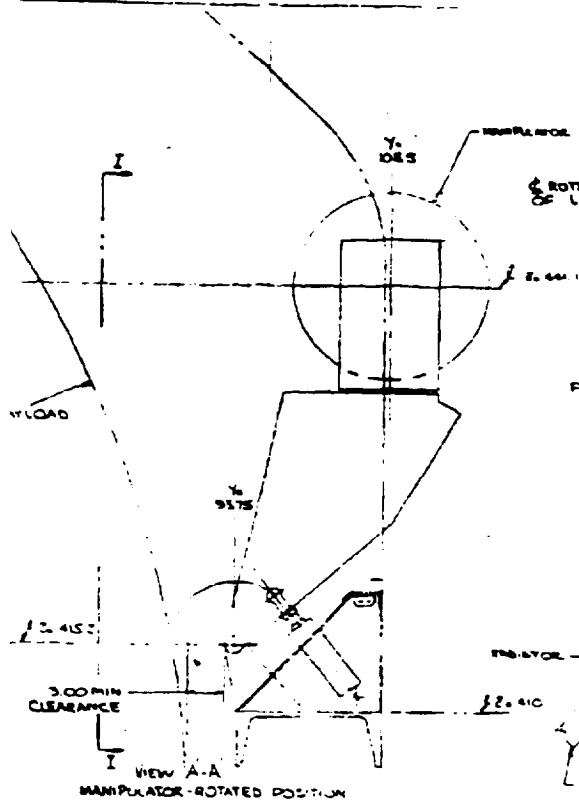
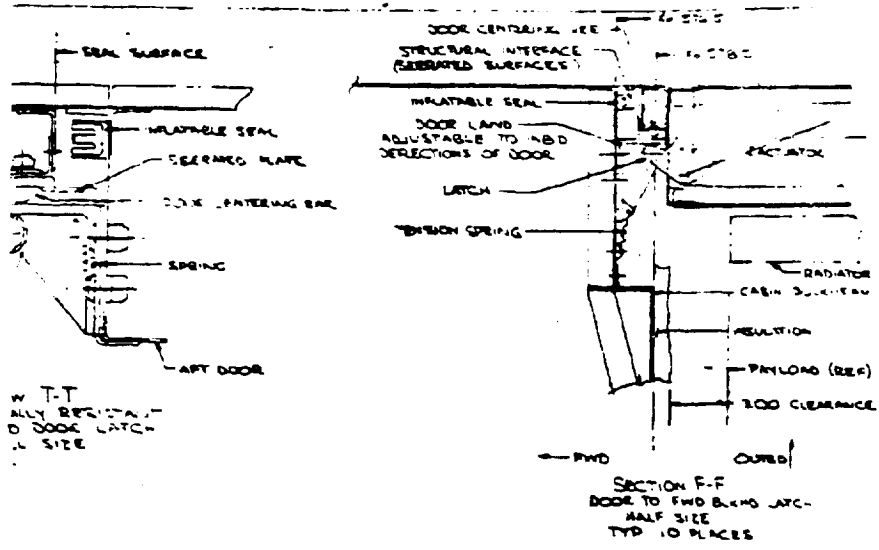

Figure 1.4.11. Mid Fuselage Main Landing Gear Support Structure



3
DEBOUT FRAME
VIEW A-A
MANIPULATOR-STOWED POSITION



W T-T
 ALLY RESISTANT
 O DOOR LATCH
 1/2 SIZE

DOOR HANDLE RESTRAINT
 TYP 10 PLACES

RADIATOR TRAIL STOP & W/SPACE
 RADIATOR 3 RESTRAINT L
 DOOR NOT IN

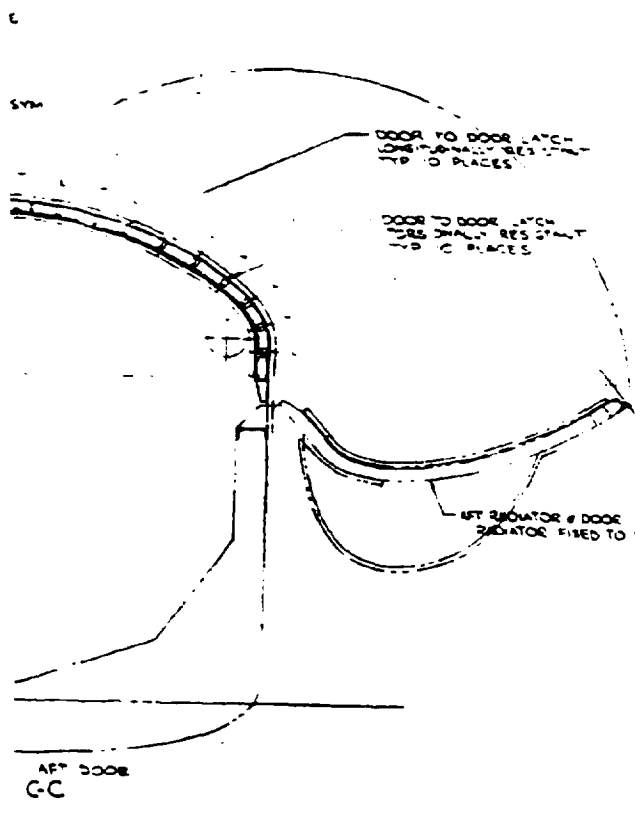

DOOR HANDLE RESTRAINT
 TYP 10 PLACES

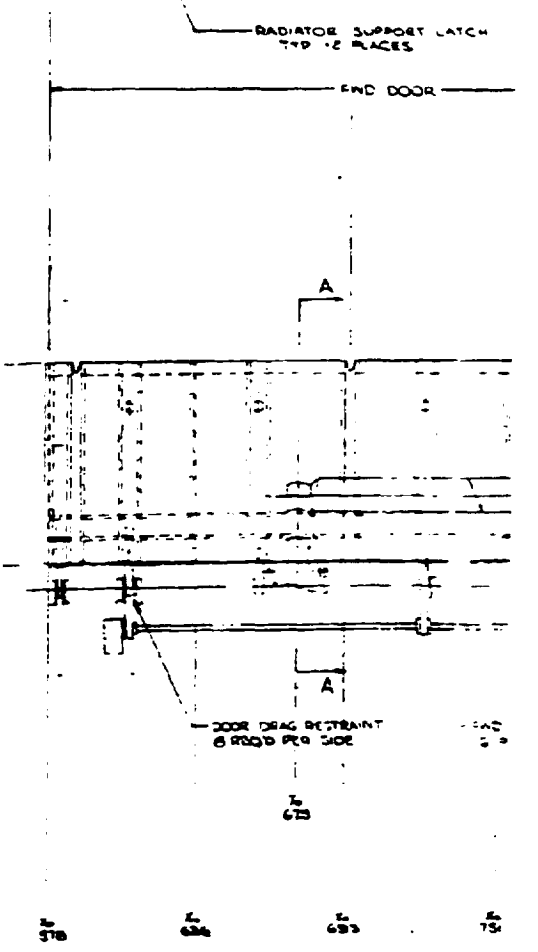
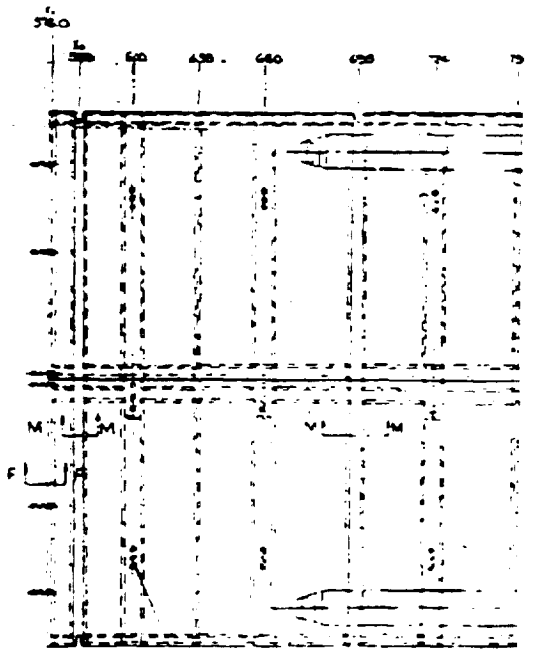

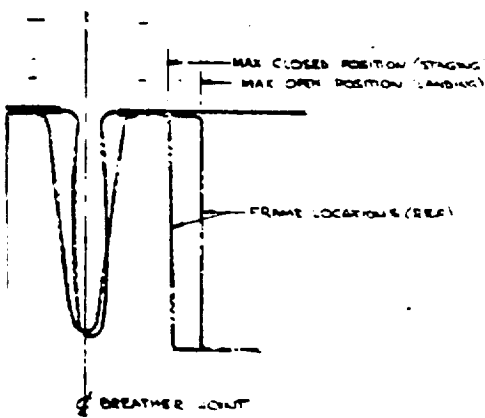

NOTES

1. THIS DRAWING IS ASSOCIATED WITH THE FOLLOWING DRAWINGS:
 - VL70-000144 LINES DEFINITION
 - VL70-004033 CARGO BAY DOOR VIB 50TH BASELINE
 - VL70-004037 RADIATOR DOOR INSTALLATION
 - RL70-004106 DOOR TO DOOR LATCH INTERFACE #63303
 - VL70-004031 ART BLEND REFERENCE
 - VL70-004107 DOOR TO DOOR LATCH #63303 AND END BLEND LATCH #63303
2. PAYLOAD DOORS ARE TO BE TOP-OVERHUNG, RESISTANT AND ARE NOT TO TAKE AXIAL LOADS.

SECTION M-M
FULL SIZE
10 PLACES PER SIDE

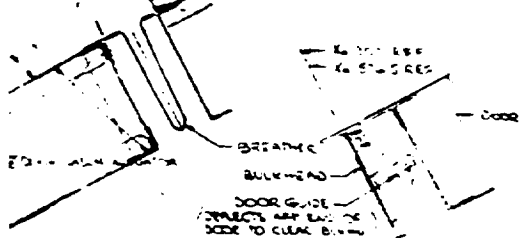

SECTION R-R
HALF SIZE
10 PLACES

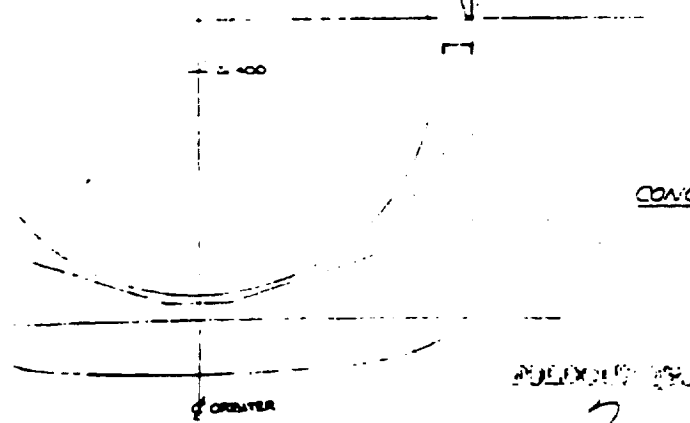
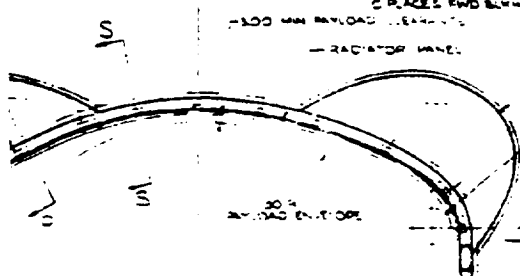

CONCEPT-A-1'S SEGMENT 1, 2, 3

ANALYSIS RESULTS

Figure 1.4.12. Mid Fuselage Payload Bay Doors

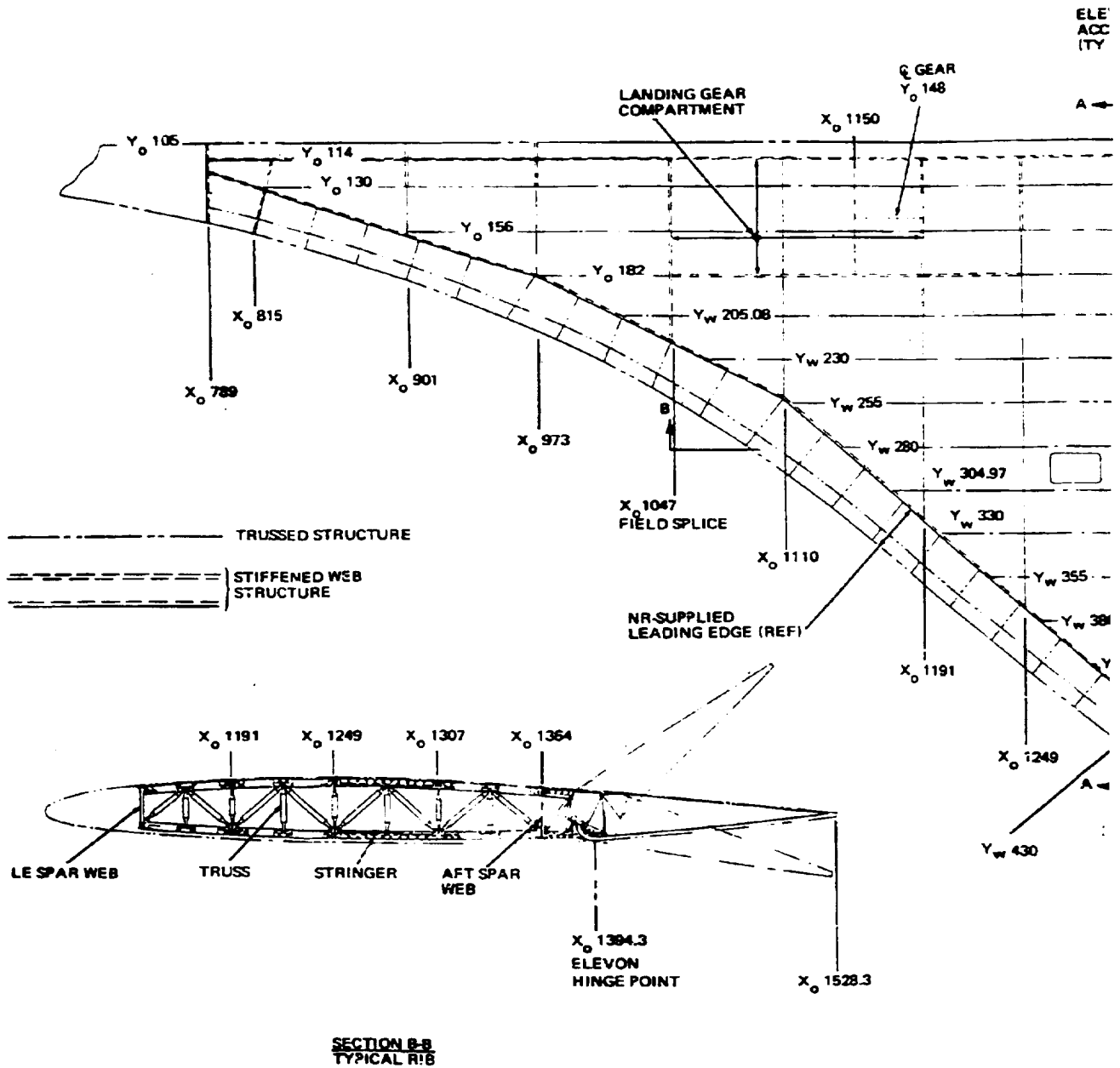

REPRODUCIBILITY OF THE ORIGINAL PAGE IS POOR

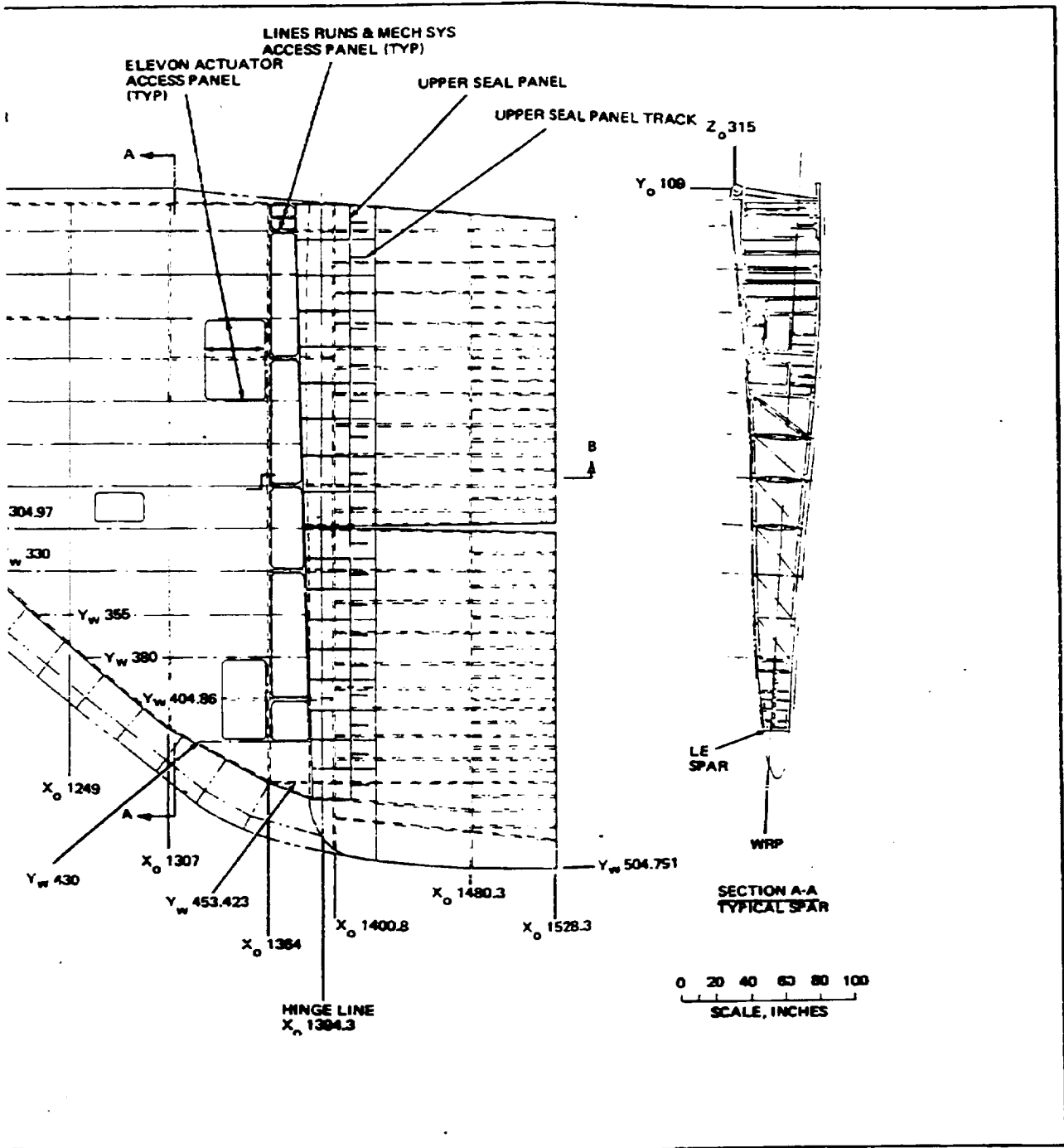
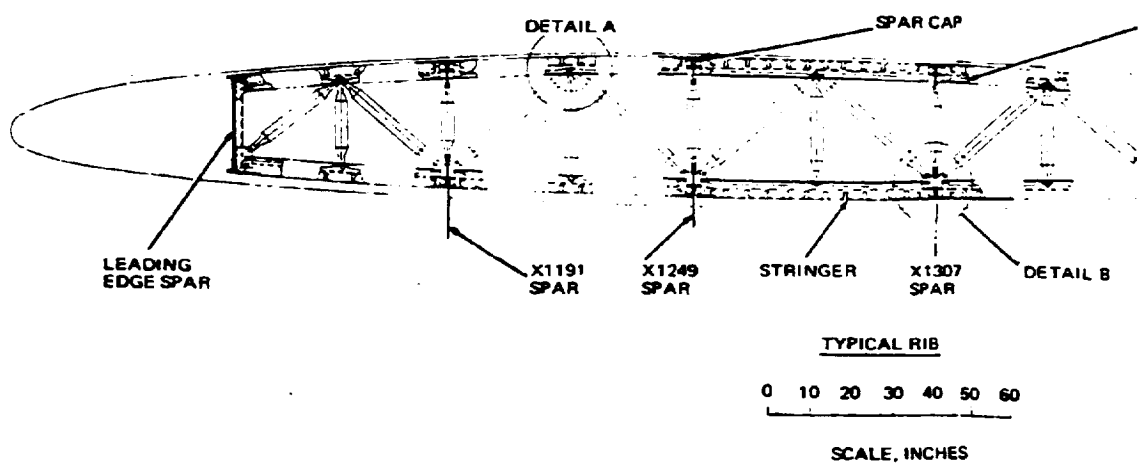
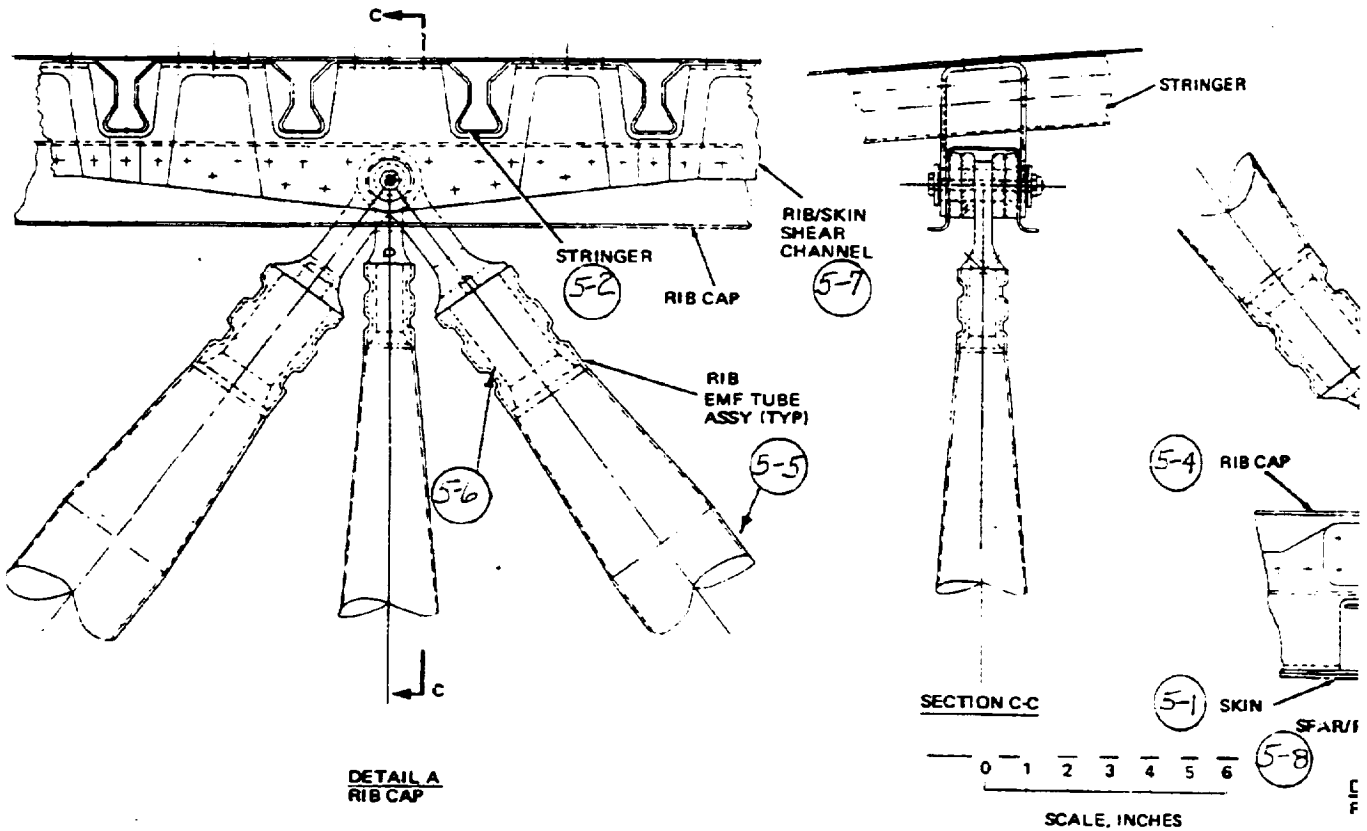
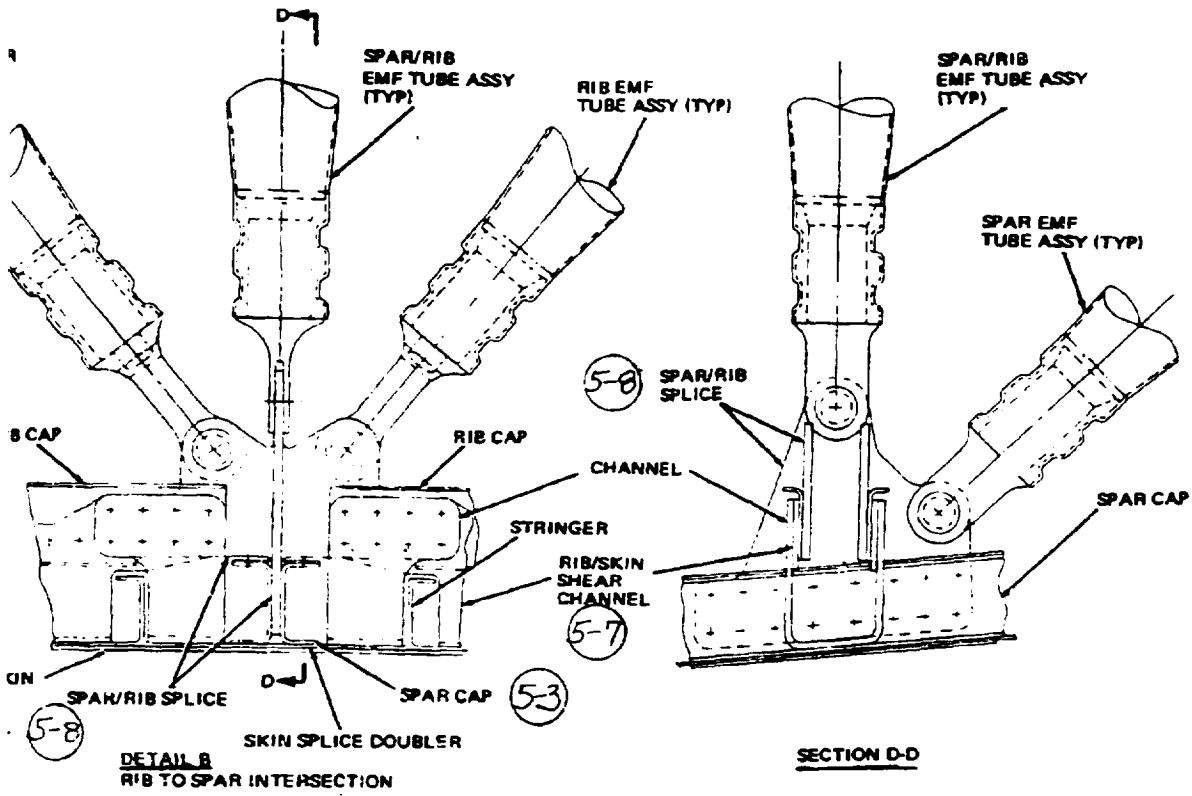

Figure 1.5.1. Wing Structure Subsystem Structural Arrangement





EMF: ELECTRO-MAGNETIC FORMING

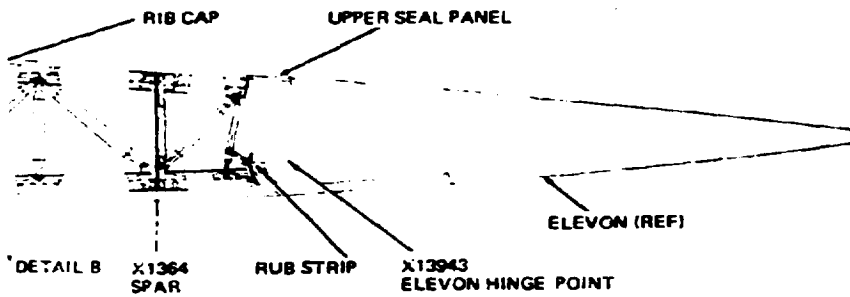
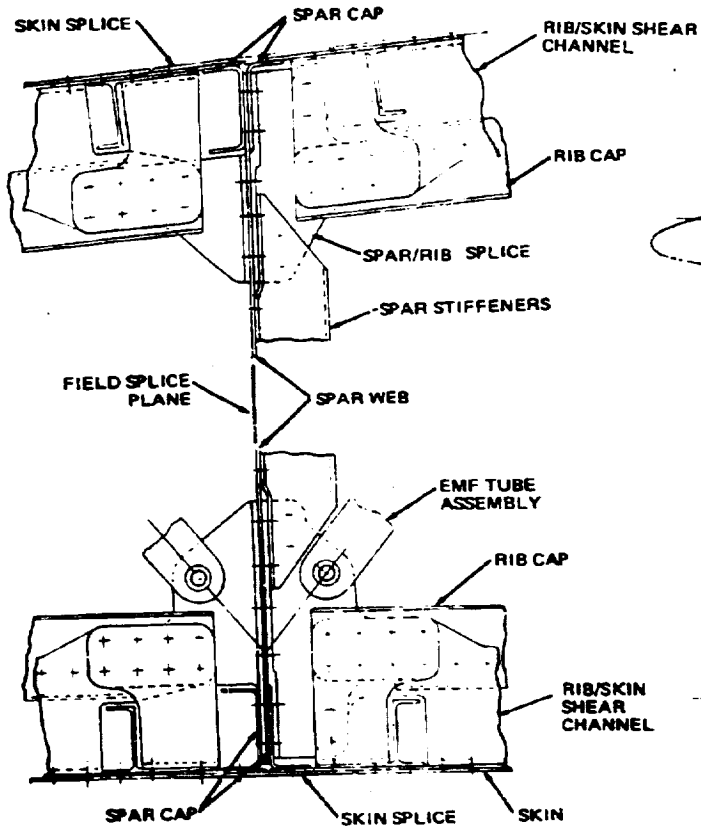
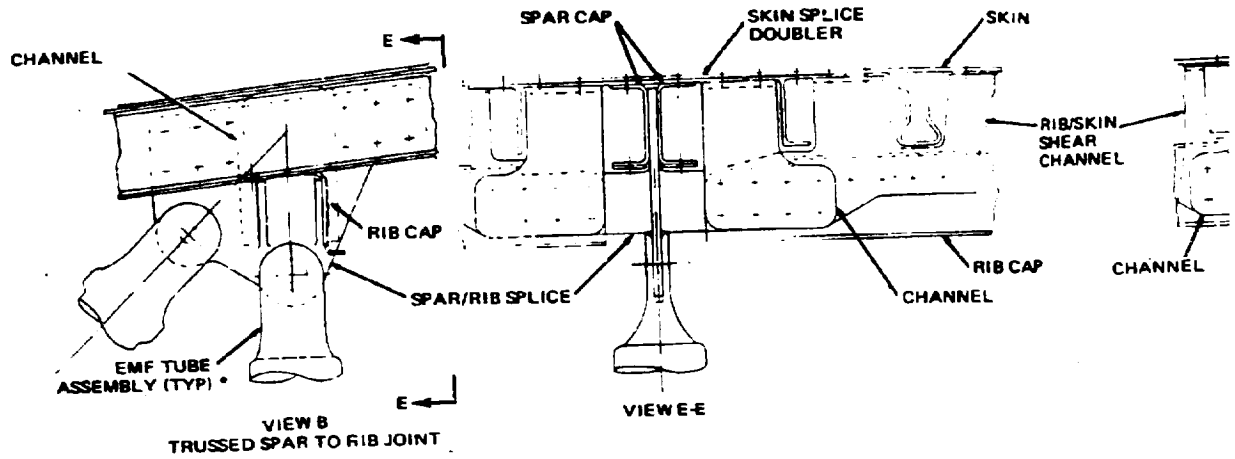
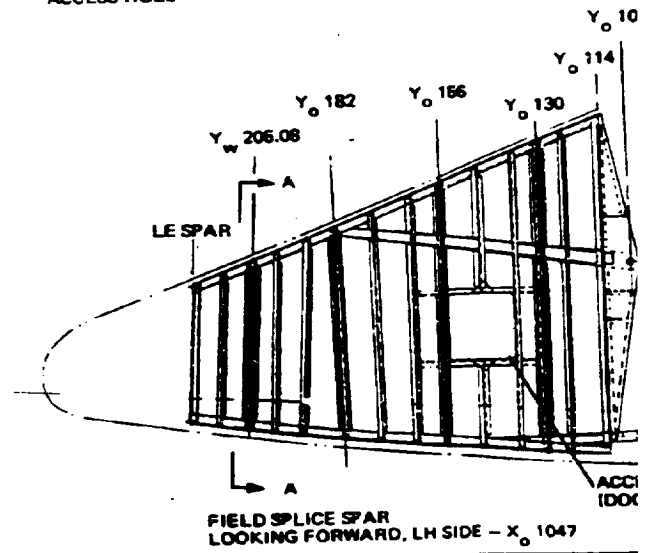
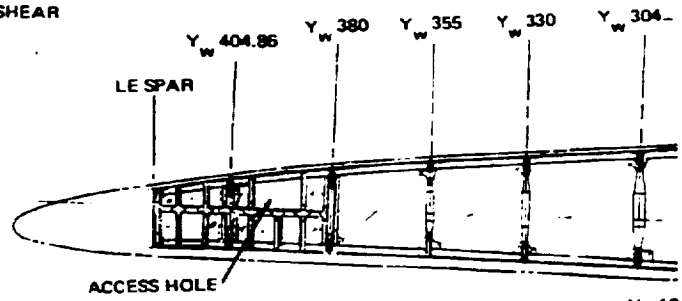

Figure 1.5.2. Wing Assembly Rib Construction



SECTION A-A
FIELD SPLICE JOINT



2-1-108

WELDOUT FRANK

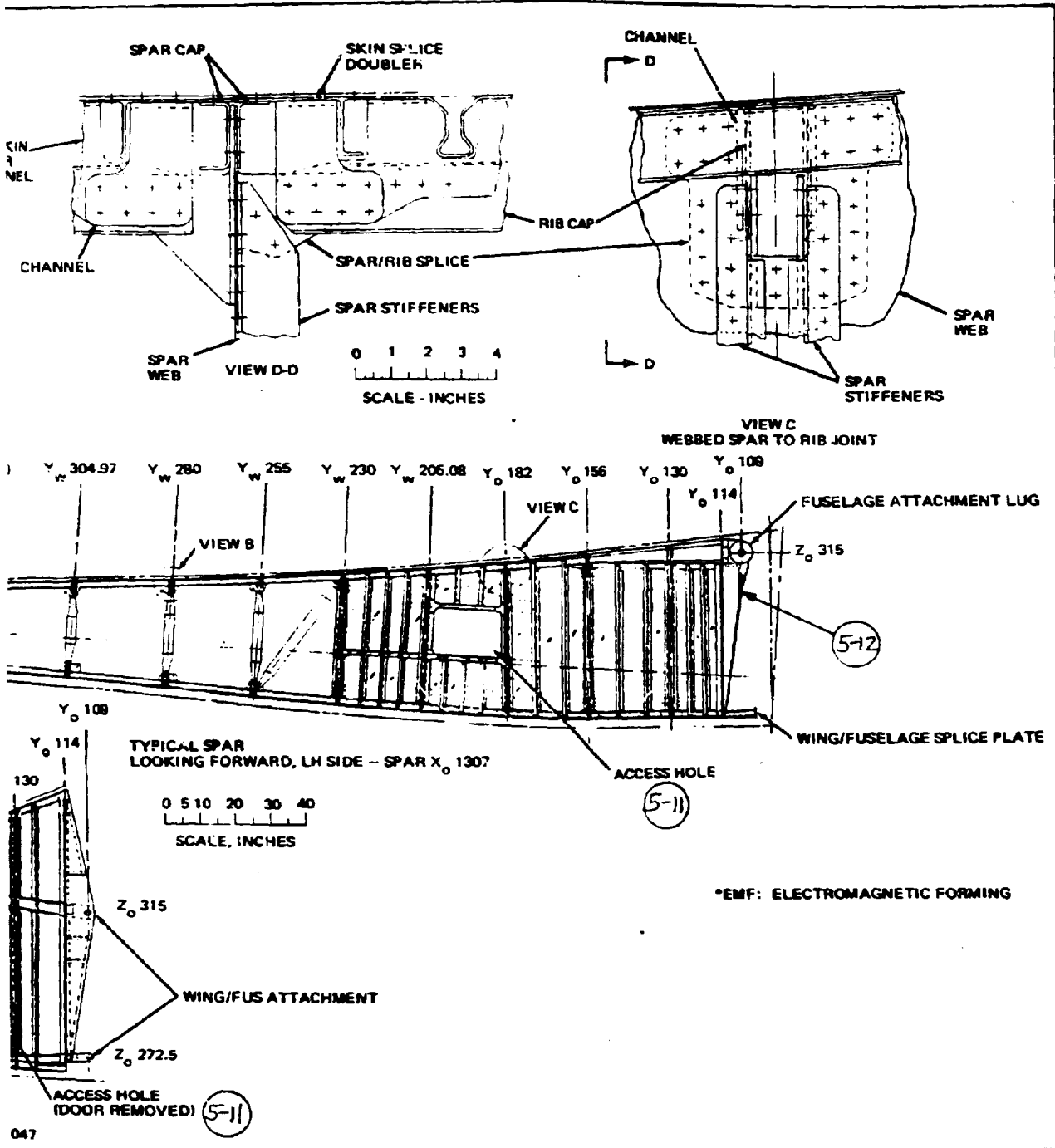
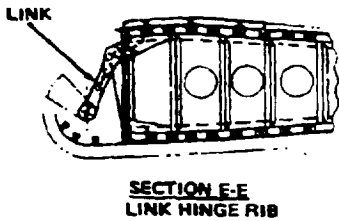
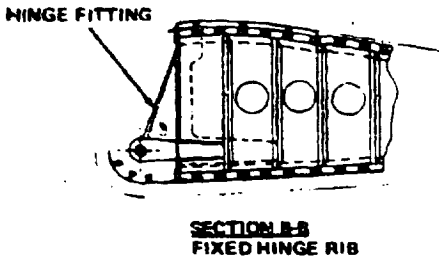
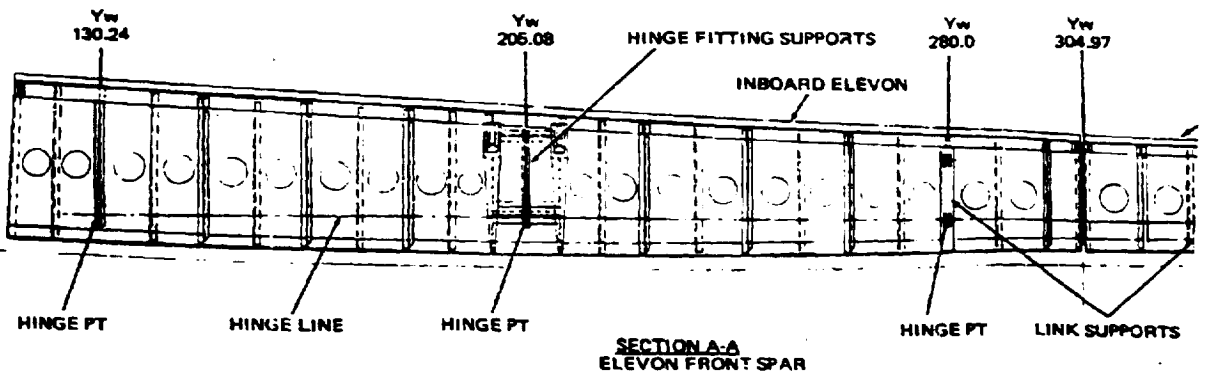
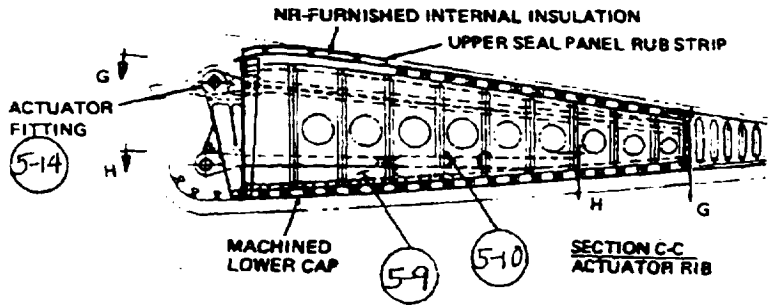
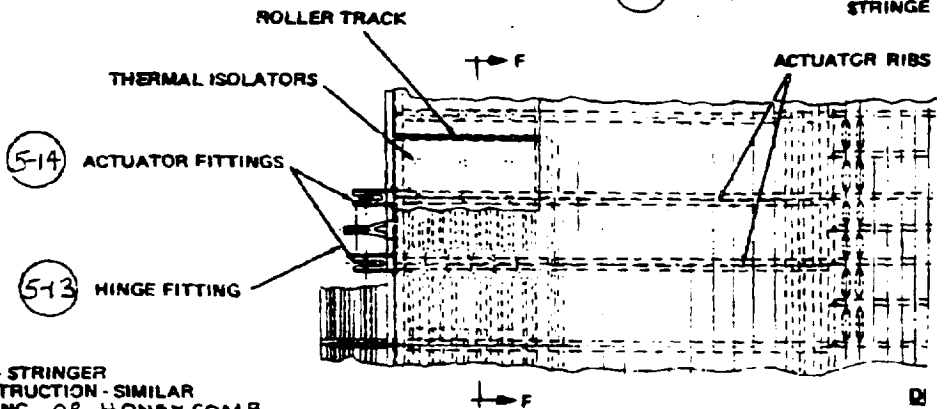
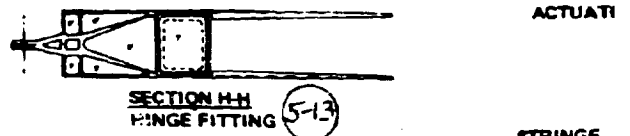
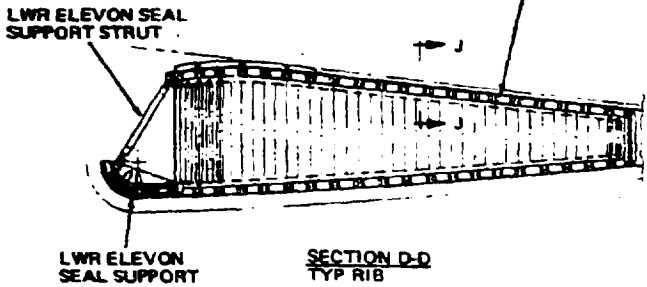

Figure 1.5.3. Wing Assembly Spar Construction



(5-15) SKIN - STRINGER
CONSTRUCTION - SIMILAR
TO WING OR HONEY COMB



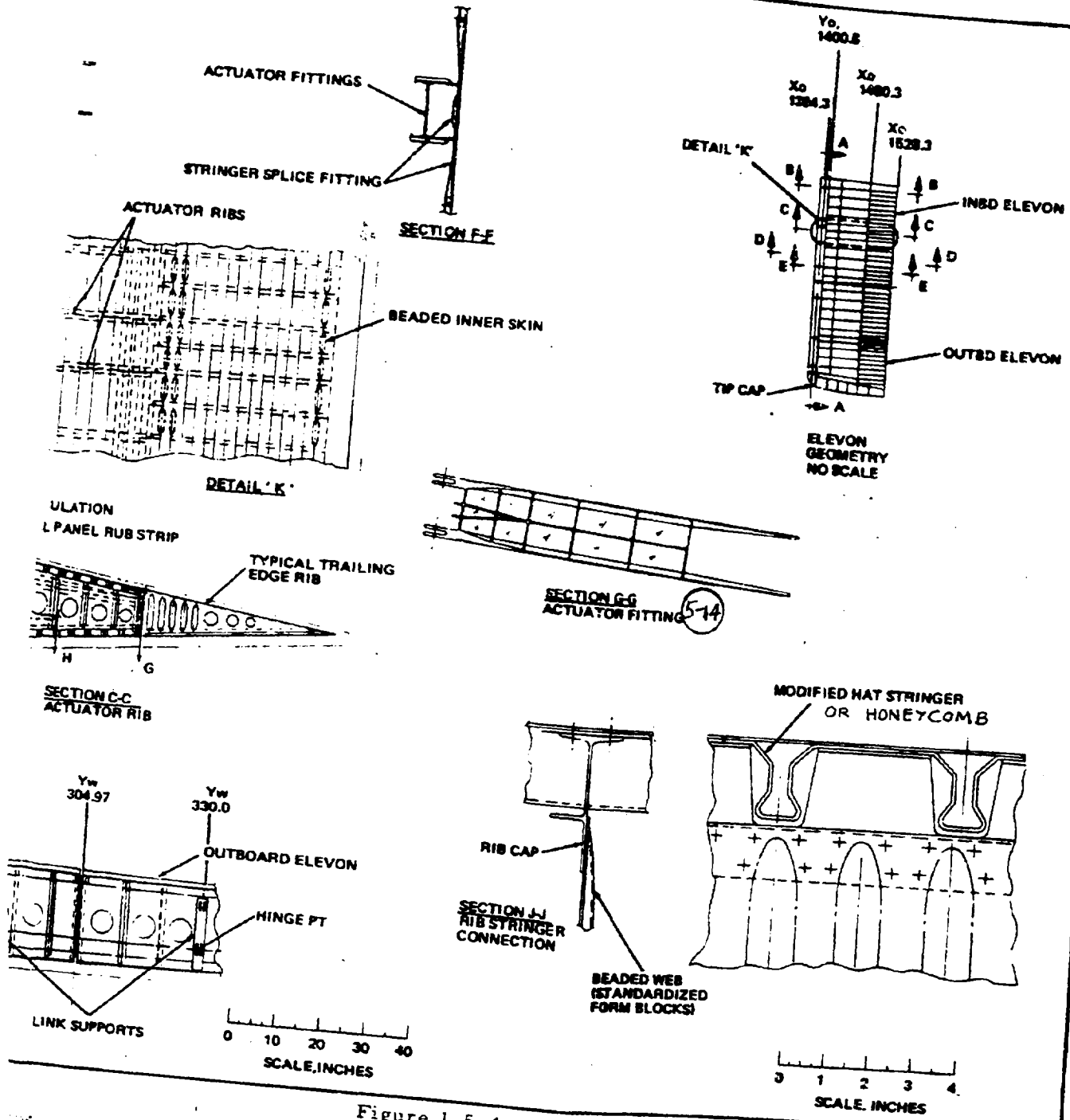
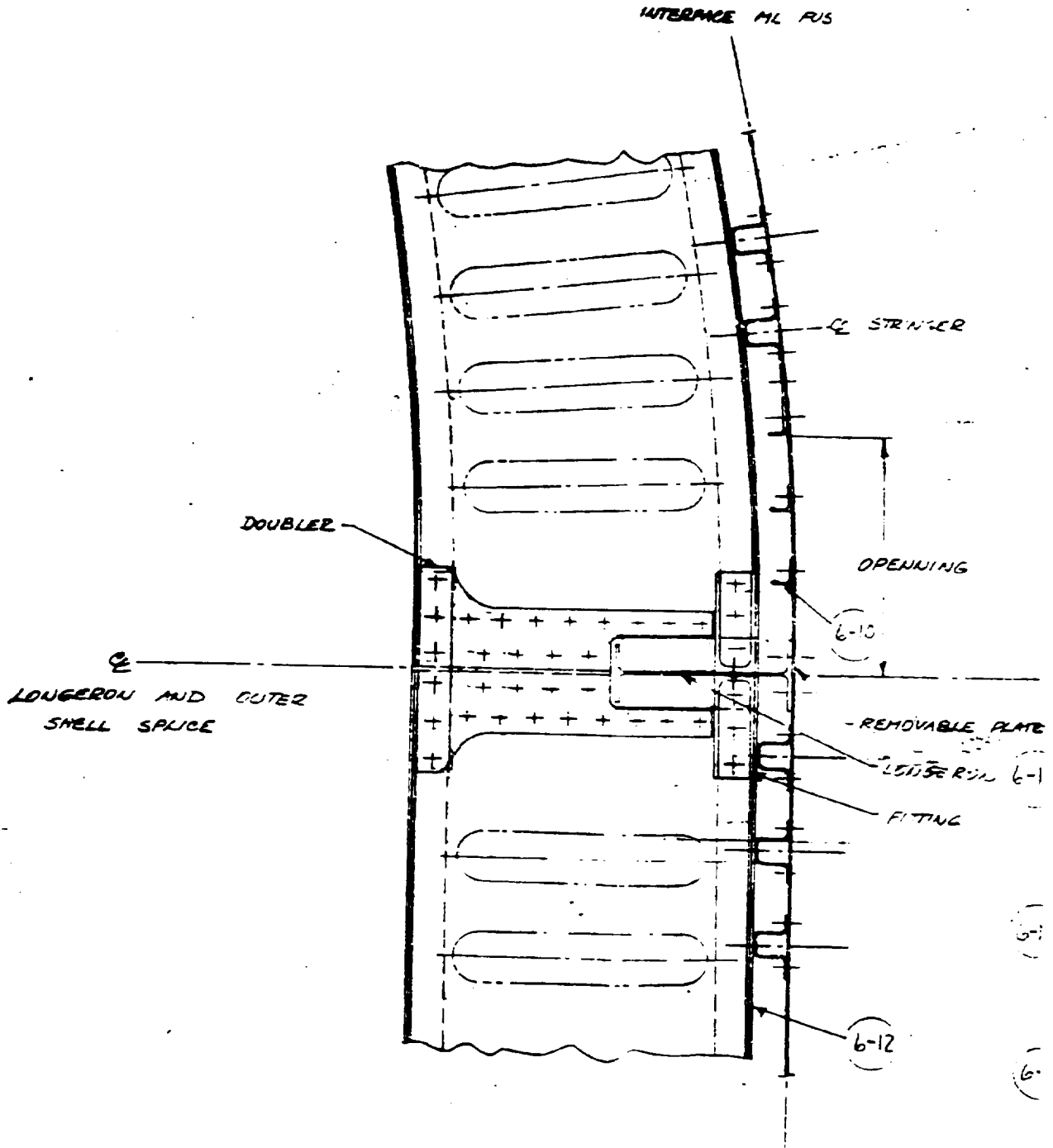

Figure 1.5.4. Elevon Assembly Construction

REPRODUCIBILITY OF THE ORIGINAL PAGE IS POOR



SECTION N - N

SCALE 1/2

WELDOUT FRAME

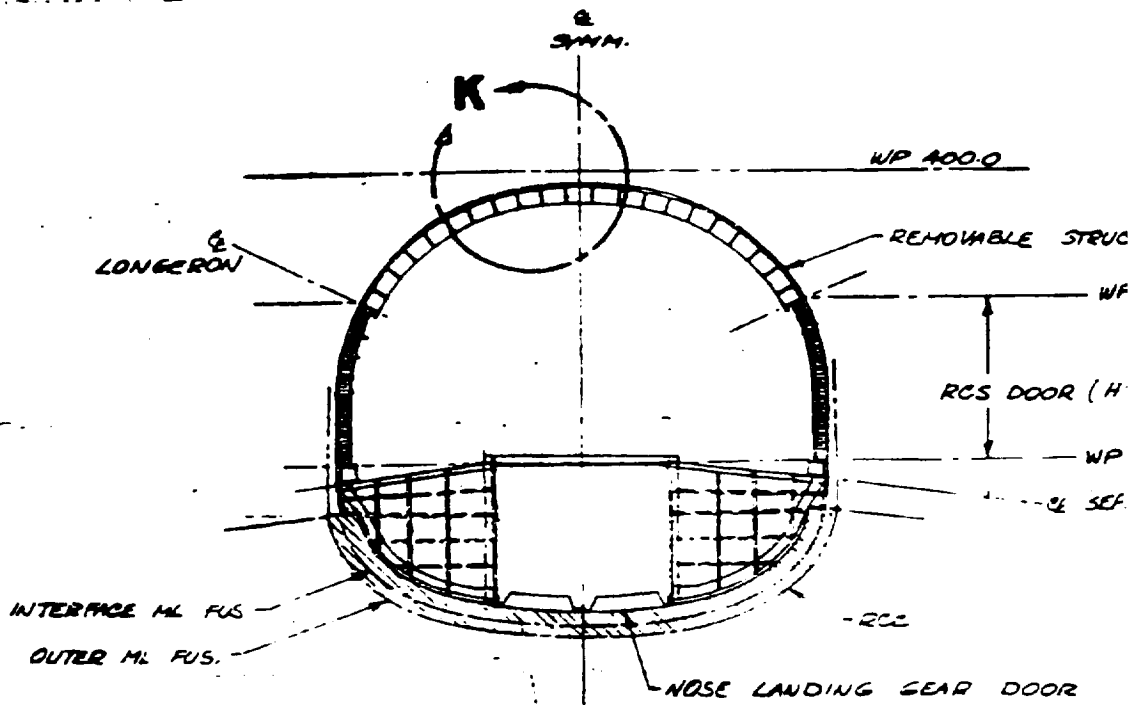

REPRODUCIBILITY OF THE ORIGINAL PAGE IS POOR

SECTION G - G
STA. 2200

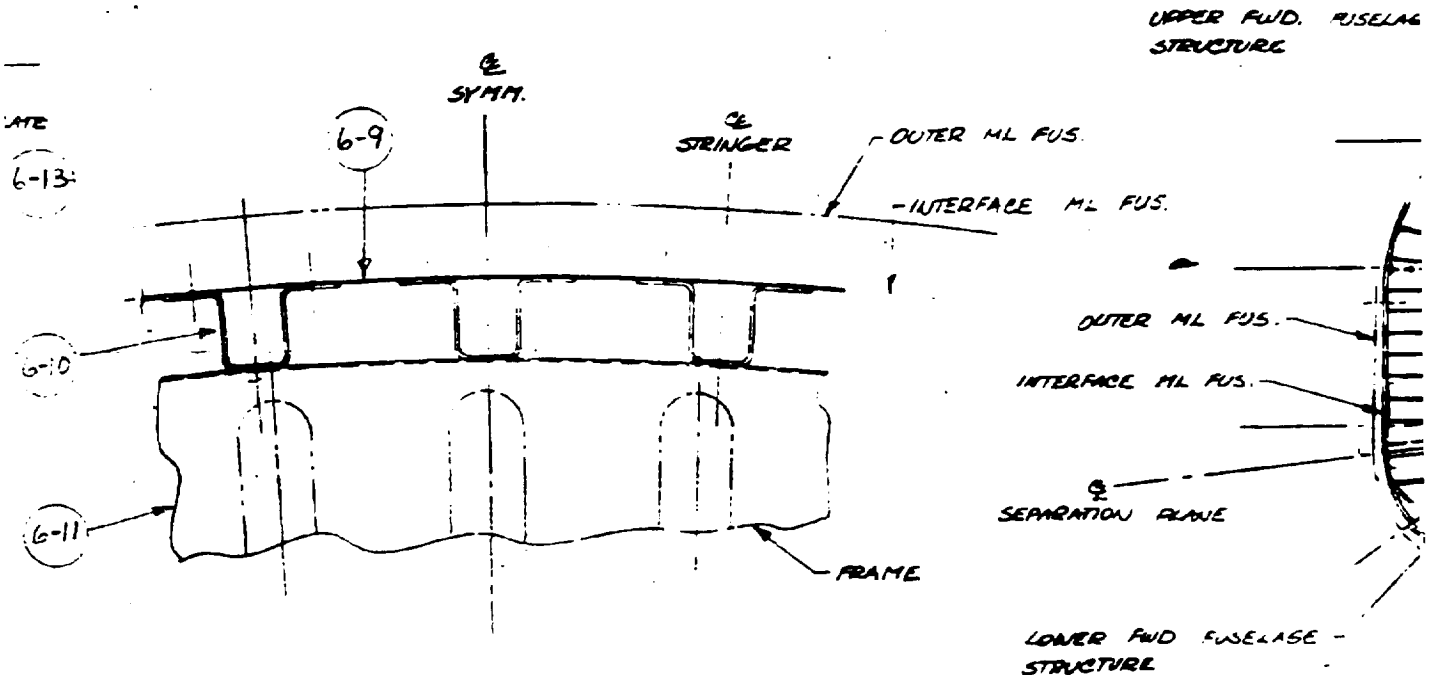

VIEW K

SCALE 1/1

TYP FOR ALL FRAME EXCEPT BULKHEADS

WAKE STRUCTURE AND RCS SYSTEM

WP 369.0

DOOR (HONEYCOMB)

WP 330.0

SEPARATION PLANE

DOOR

FUSELAGE

SYMM.

CABIN (REF.)

INTERFACE ML FUS.

OUTER ML FUS.

CABIN (REF.)

RCC

LONGERON

SECTION E - E

STA. 442.0

OUTER ML FUS.

LONGERON &
OUTER SHELL SPLICE

INTERFACE ML FUS.

WP 330.0

BULKHEAD FWD FUSELAGE
TEMPERATURE

CABLE SPLICE

RCC

LONGERON

SECTION C - C

STA. 372.0

1270

S.M.

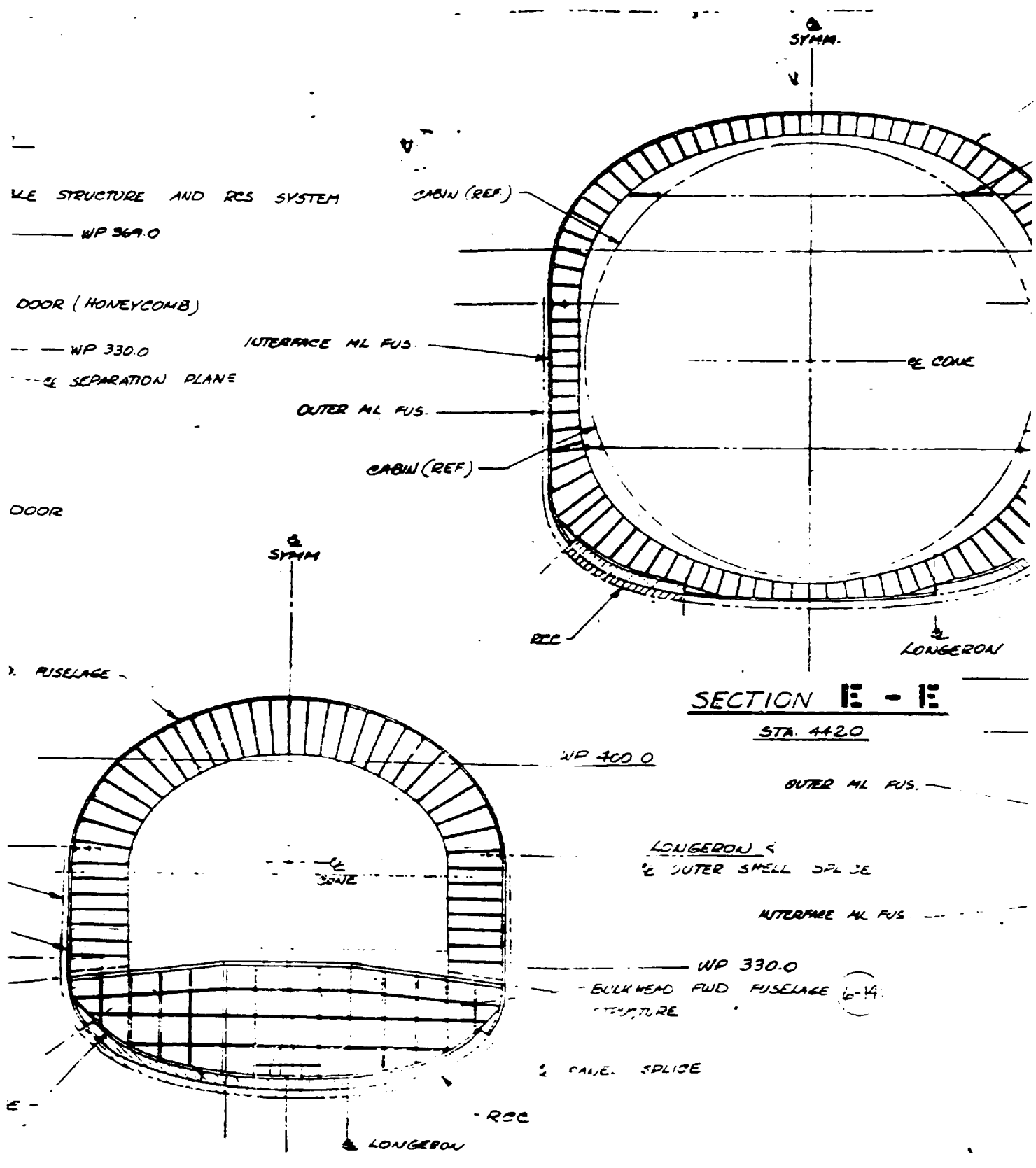

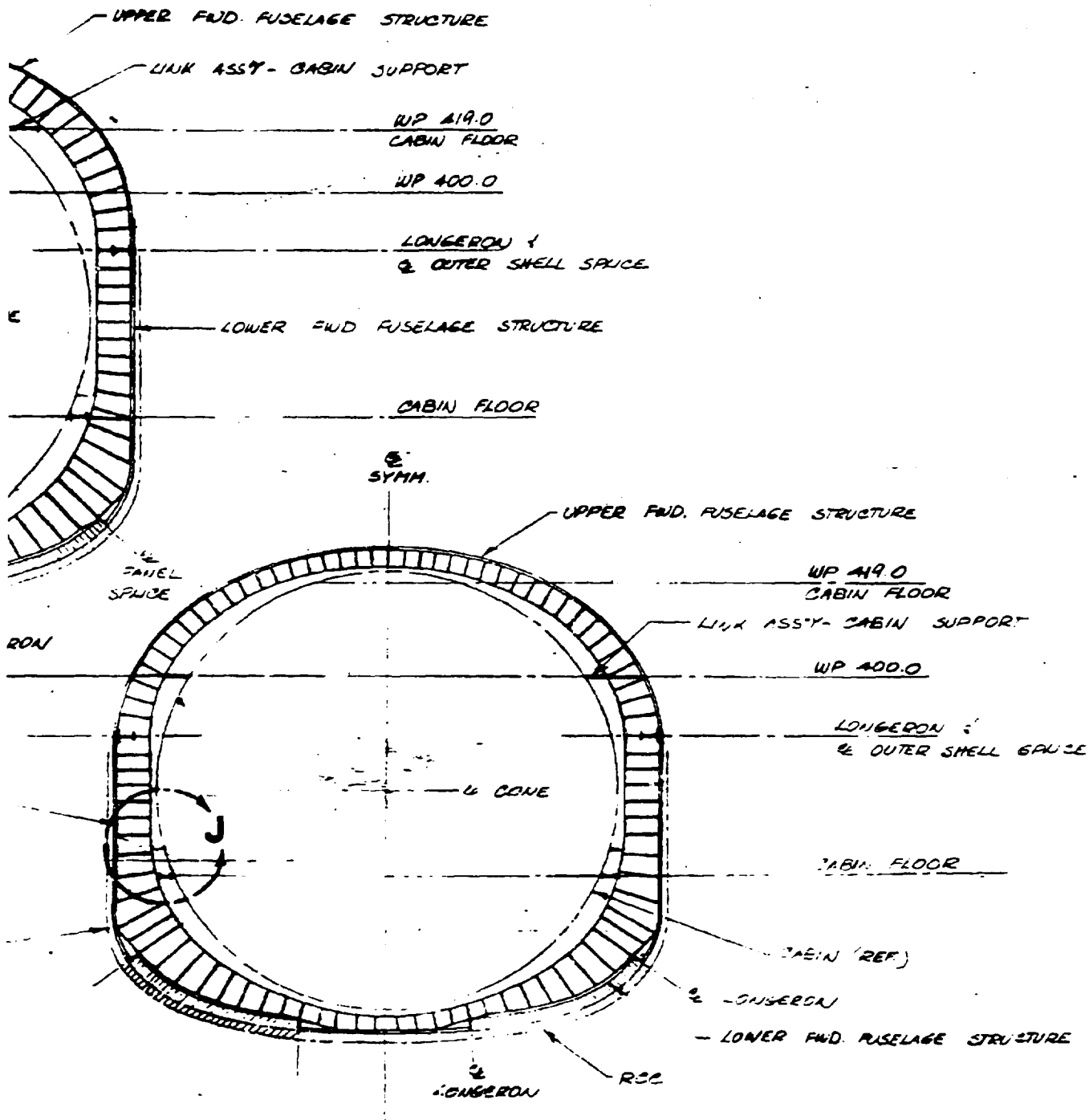

SECTION D - D
 STA. 407.2

FRAME

PORT

LL SPACE

STRUCTURE

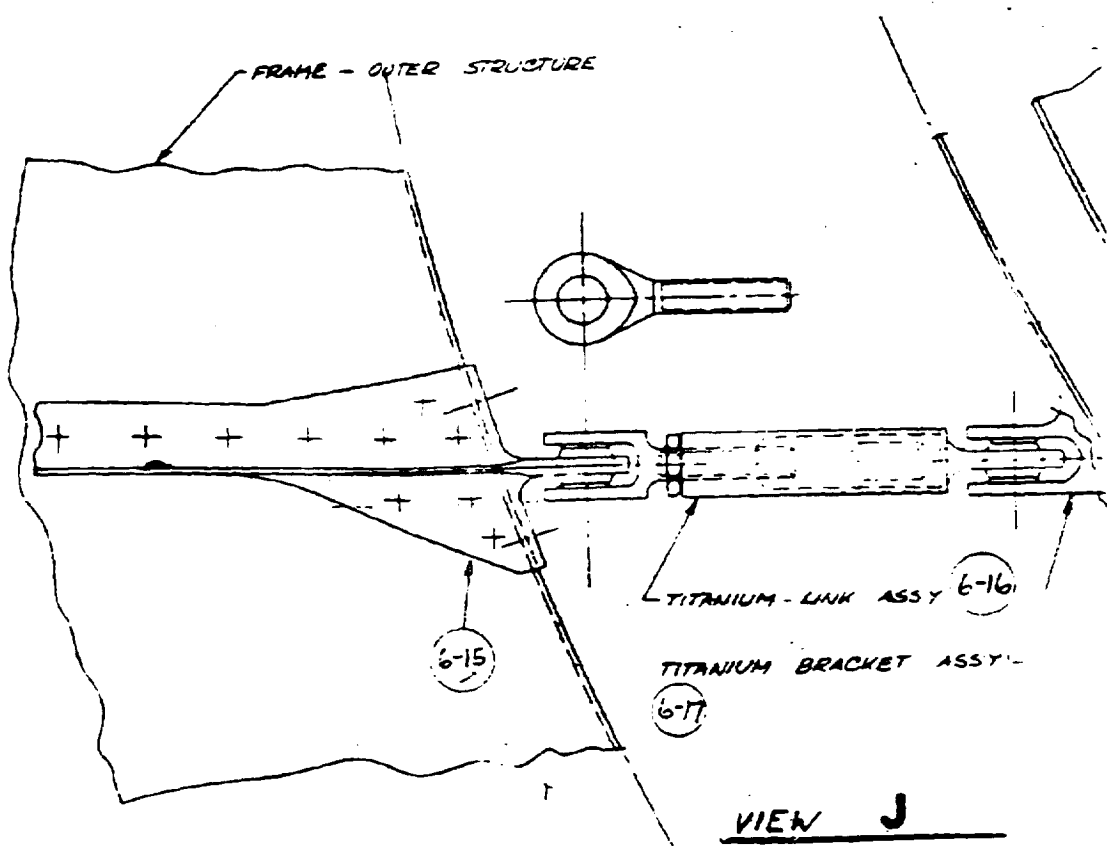

VIEW J

SCALE 1/1

DETAIL OF LINK ASSY - CREW 200

FOLDOUT FRAME



REPRODUCIBILITY OF THE ORIGINAL PAGE IS POOR

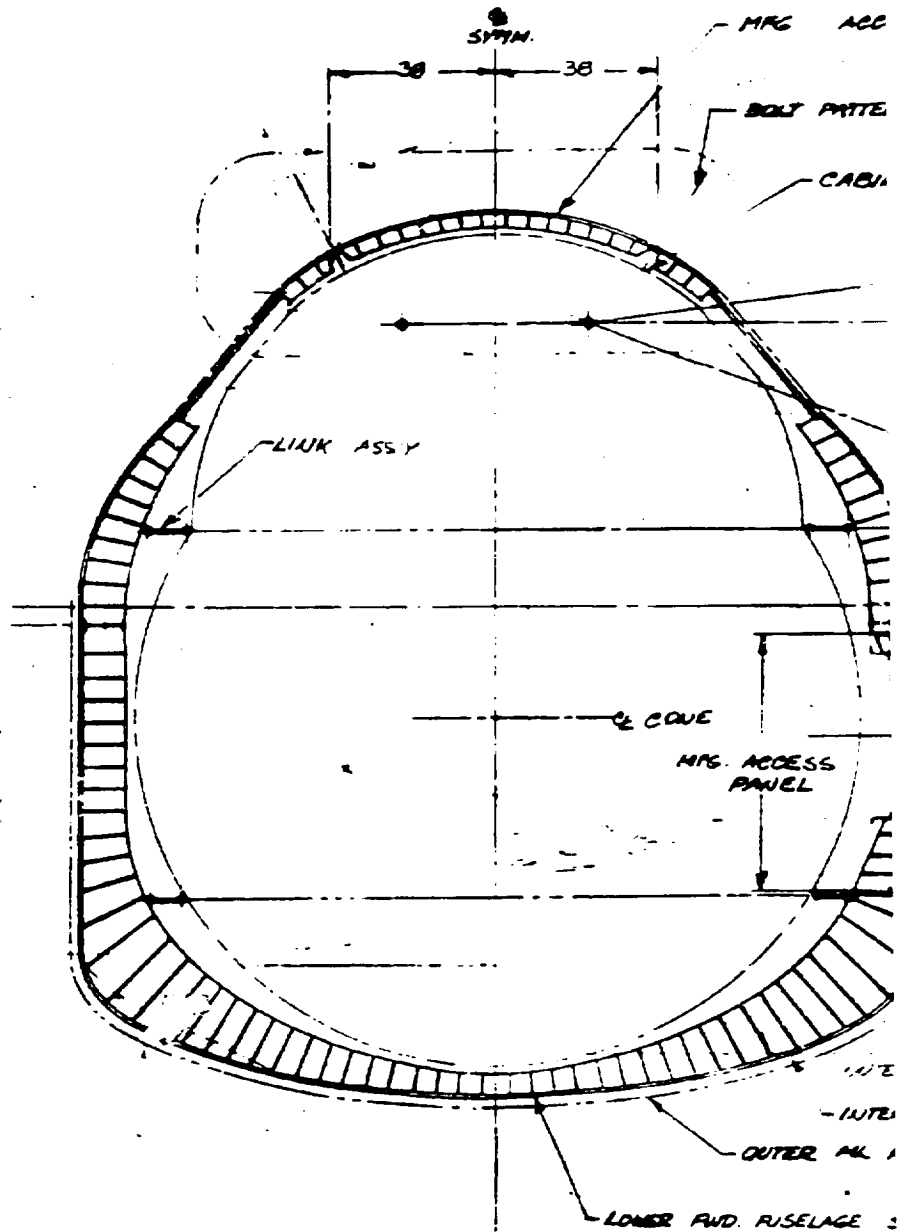
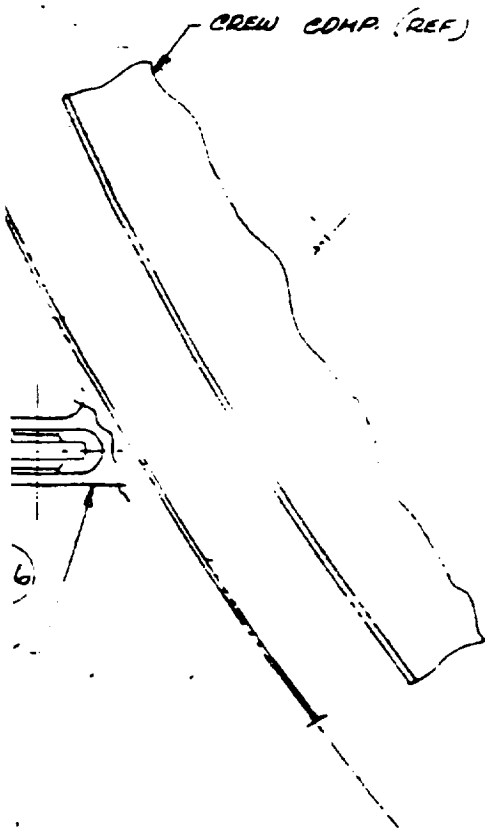

SECTION 13 - 13

STA 5090

NEW SEAT SUPPORT

DOUB FRAME

6

SYMM.

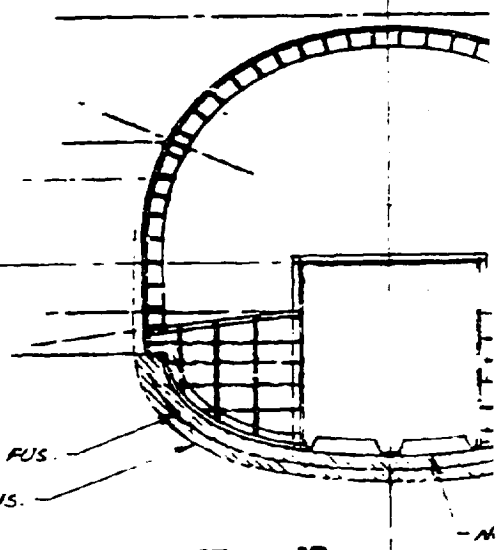

SECTION F - F

STA 300.0
NOT TO SCALE

SYMM.

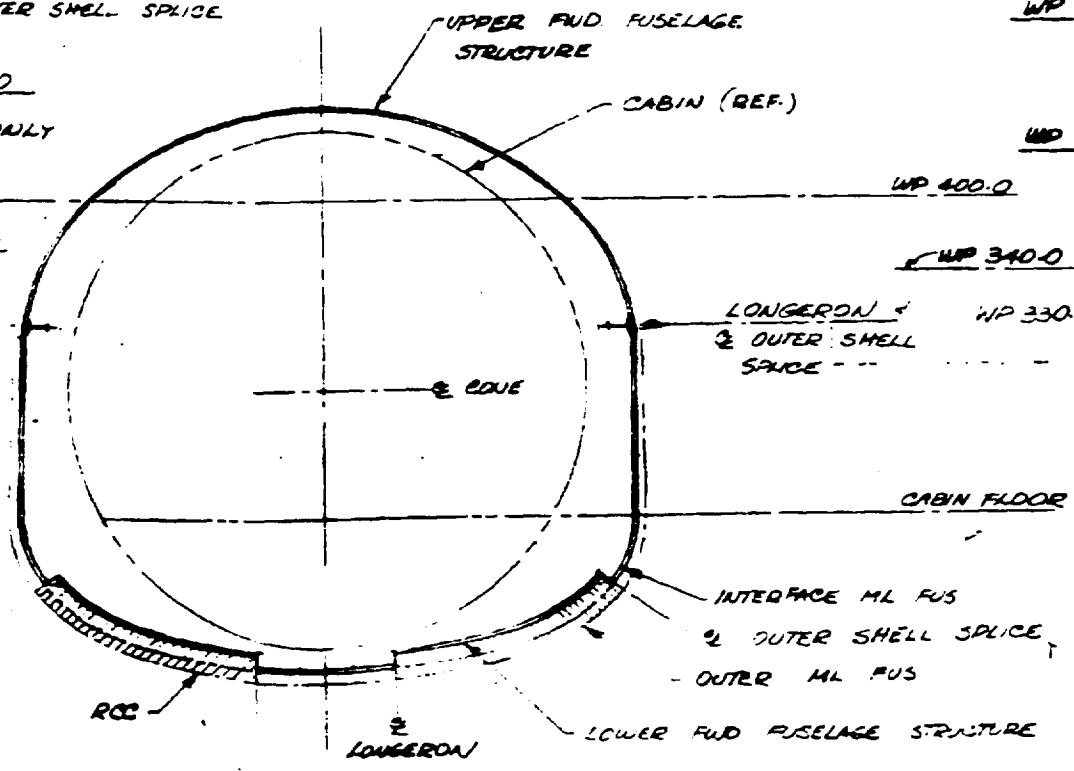

SECTION A - A

STA 378.0

ACCESS PANEL

J PATTERN

CABIN (REF.)

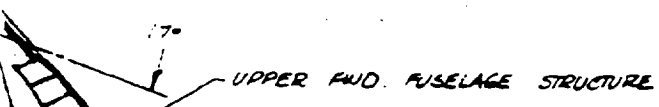
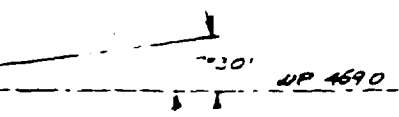

WP 419.0
CABIN FLOOR

WP 400.0
LONGERON &
OUTER SHELL SPLICE

HATCH WP 368.0
HATCH
LH SIDE ONLY

CABIN FLOOR

SS
L

OUTER SHELL SPLICE

INTERFACE ML FUS.

OR ML FUS.

FUSELAGE STRUCTURE

RCC

LONGERON

UPPER FWD FUSELAGE
STRUCTURE

CABIN (REF.)

WP 400.0

WP 340.0

LONGERON &
OUTER SHELL
SPACE

CABIN FLOOR

INTERFACE ML FUS
& OUTER SHELL SPLICE
OUTER ML FUS

LOWER FWD FUSELAGE STRUCTURE

JT FRAME

?

3

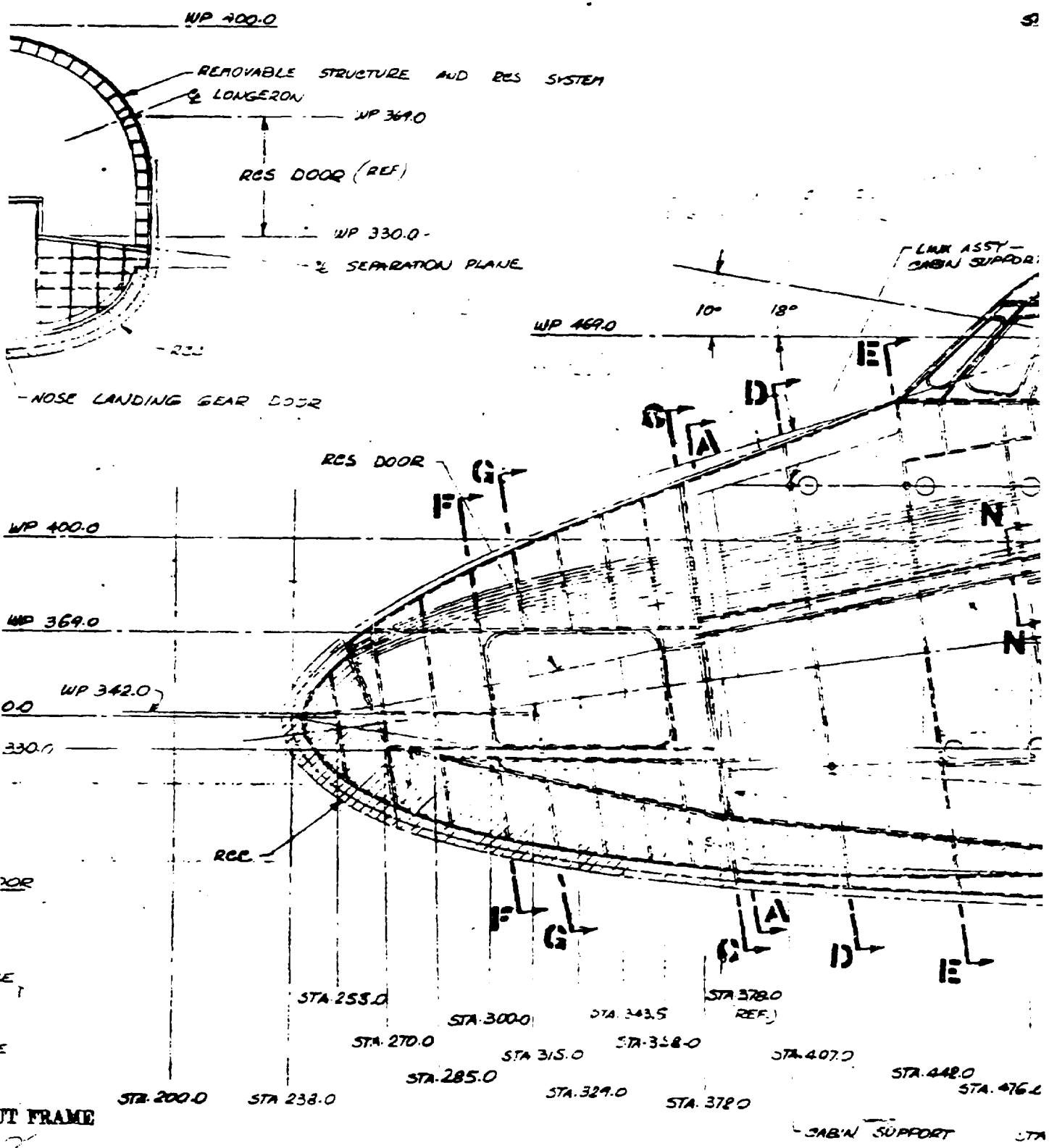

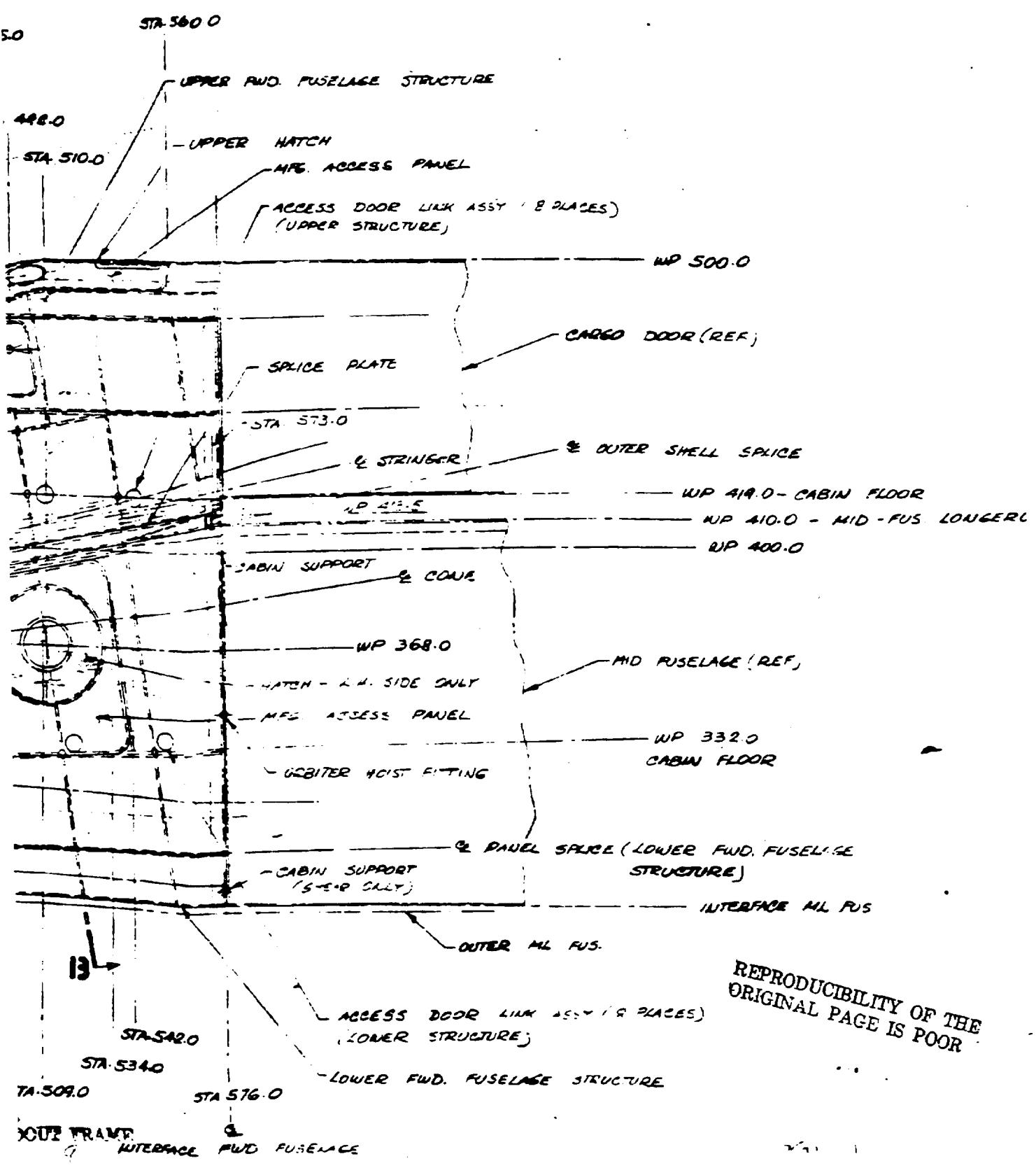

REPRODUCIBILITY OF THE
 ORIGINAL PAGE IS POOR

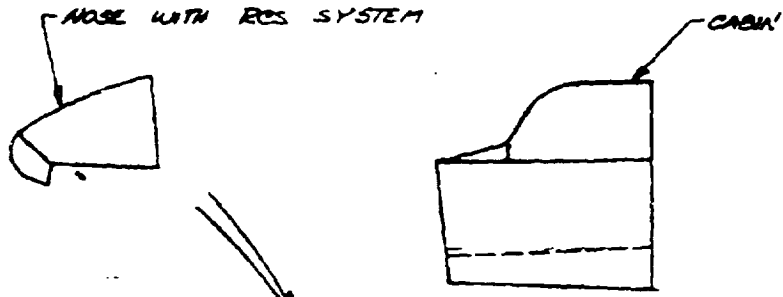

AL ALLOY
STRINGERS

1

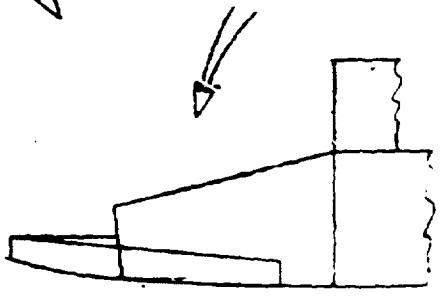

LONGERON

2

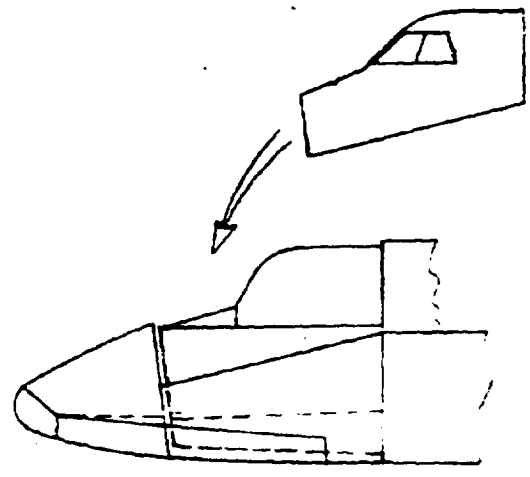

- NC
- CR
- A
- AX
- B
- E
- L
- DL
- FC
- AL
- OL
- JD
- PL

3

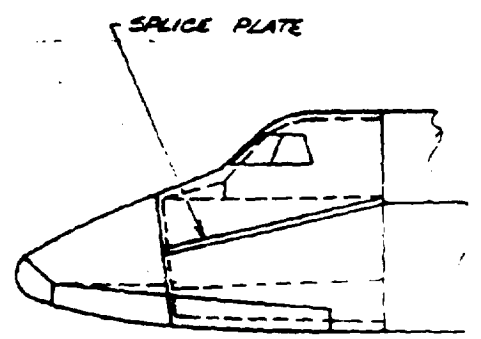

THE
OR
OUT FRAM

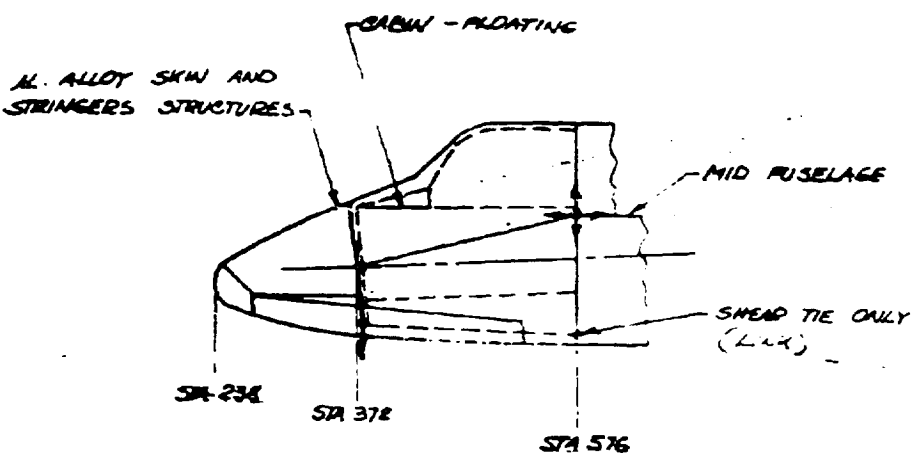

NOTES:

- CREW COMPARTMENT IS FLOATING AND IS SUPPORTED AT STA 372 AND LOADS ARE CARRIED ON Z^o AXIS ONLY. LOADS AT STA 576 ARE CARRIED ON X^o AND Z^o AXIS ONLY. LOADS AT SHEAR TIE LINK ARE CARRIED ON Y^o AXIS ONLY.
- OUTER SHELL IS SUPPORTED BY LINKS AT STA'S 4070, 4420, 4760, 5090 AND 5420
- ALL FLIGHT LOADS ARE CARRIED THRU OUTER SHELL ONLY, EXCEPT LOADS ON Y^o AXIS ARE CARRIED JOINTLY BY BOTH STRUCTURES (CABIN AND FWD. FUSELAGE STRUCTURE - OUTER - SHELL)

REPRODUCIBILITY OF THE ORIGINAL PAGE IS POOR

Figure 1.6.1. Forward Fuselage Structure

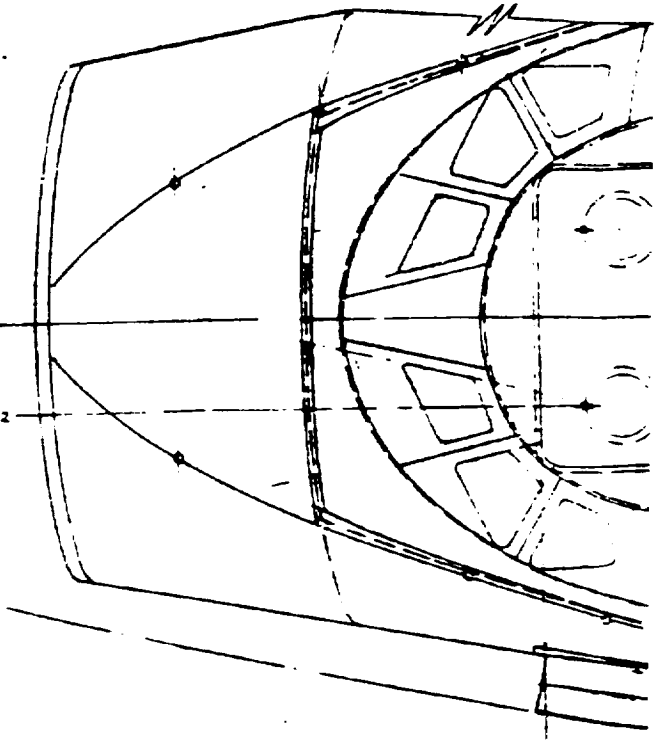
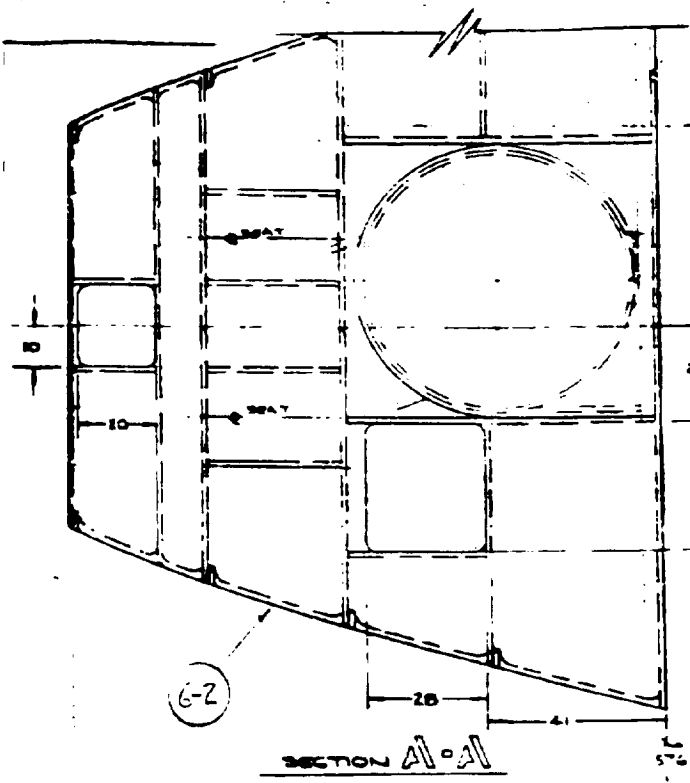

REPRODUCTION OF THE ORIGINAL DRAWING'S FOOT

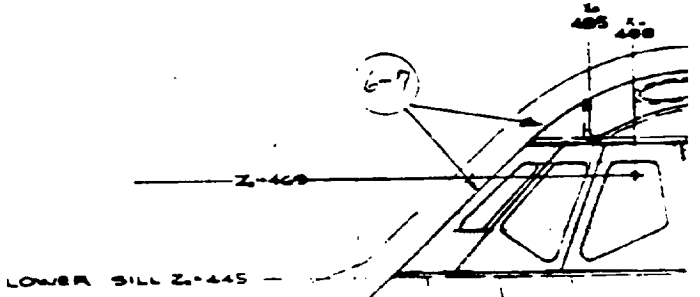

6-1
CABIN PWD BULKHEAD

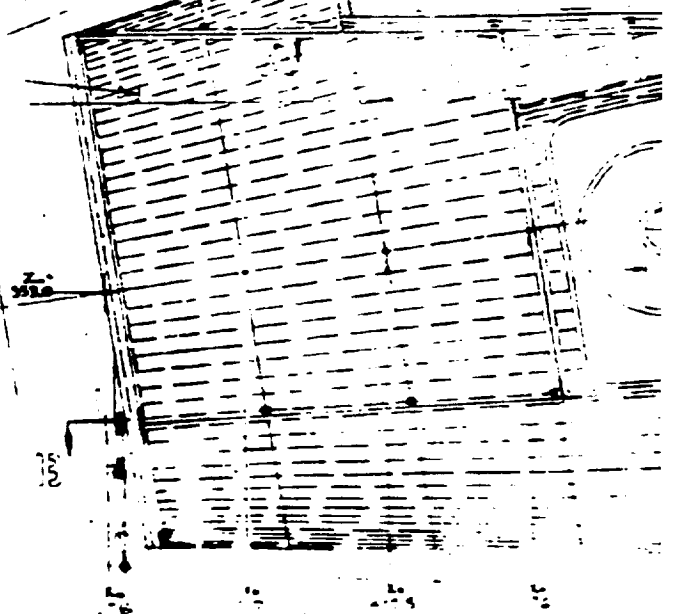
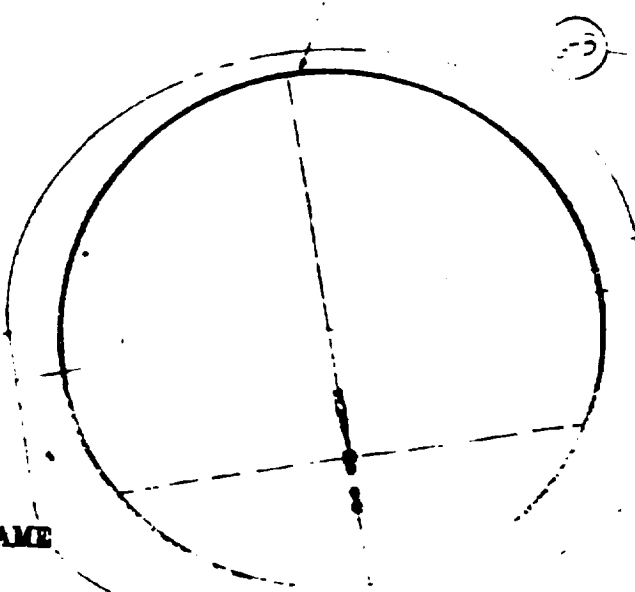

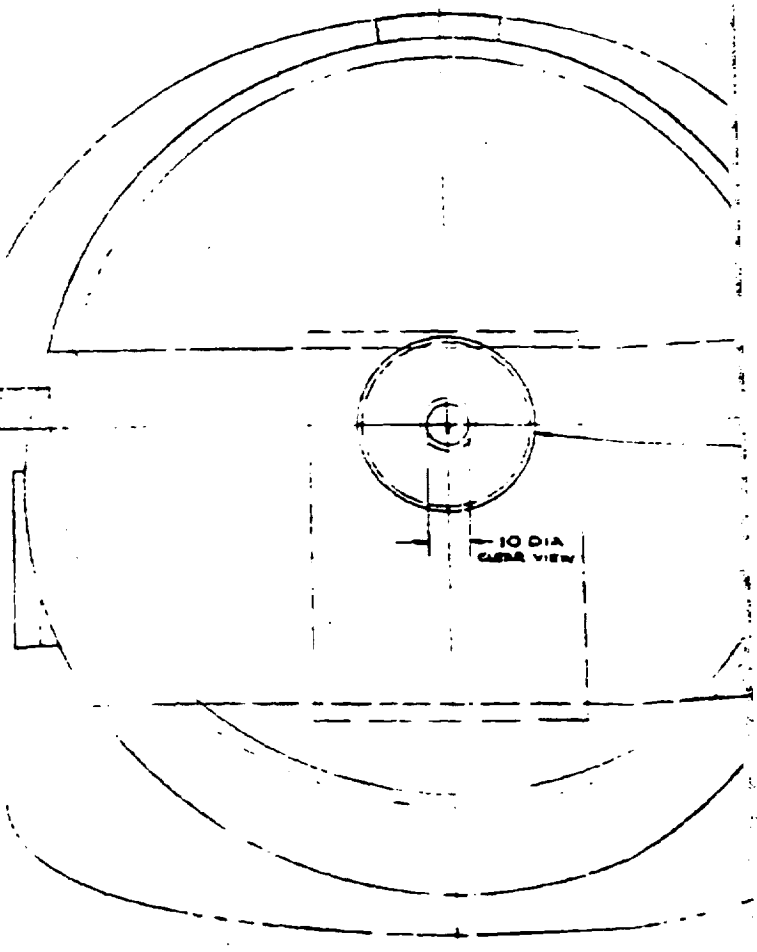
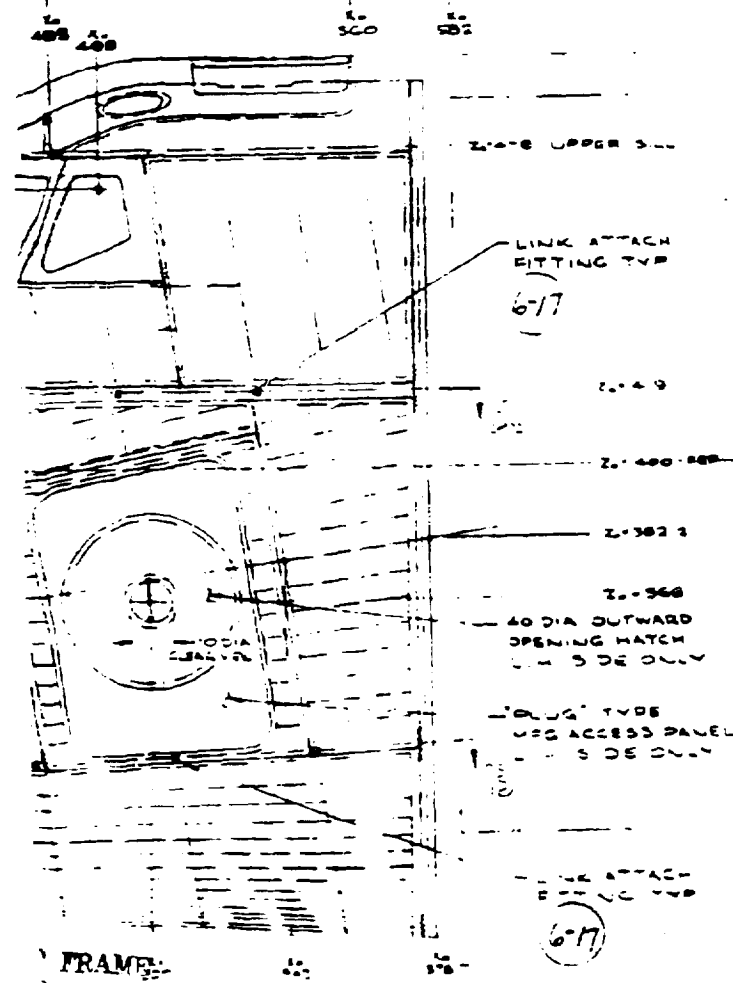
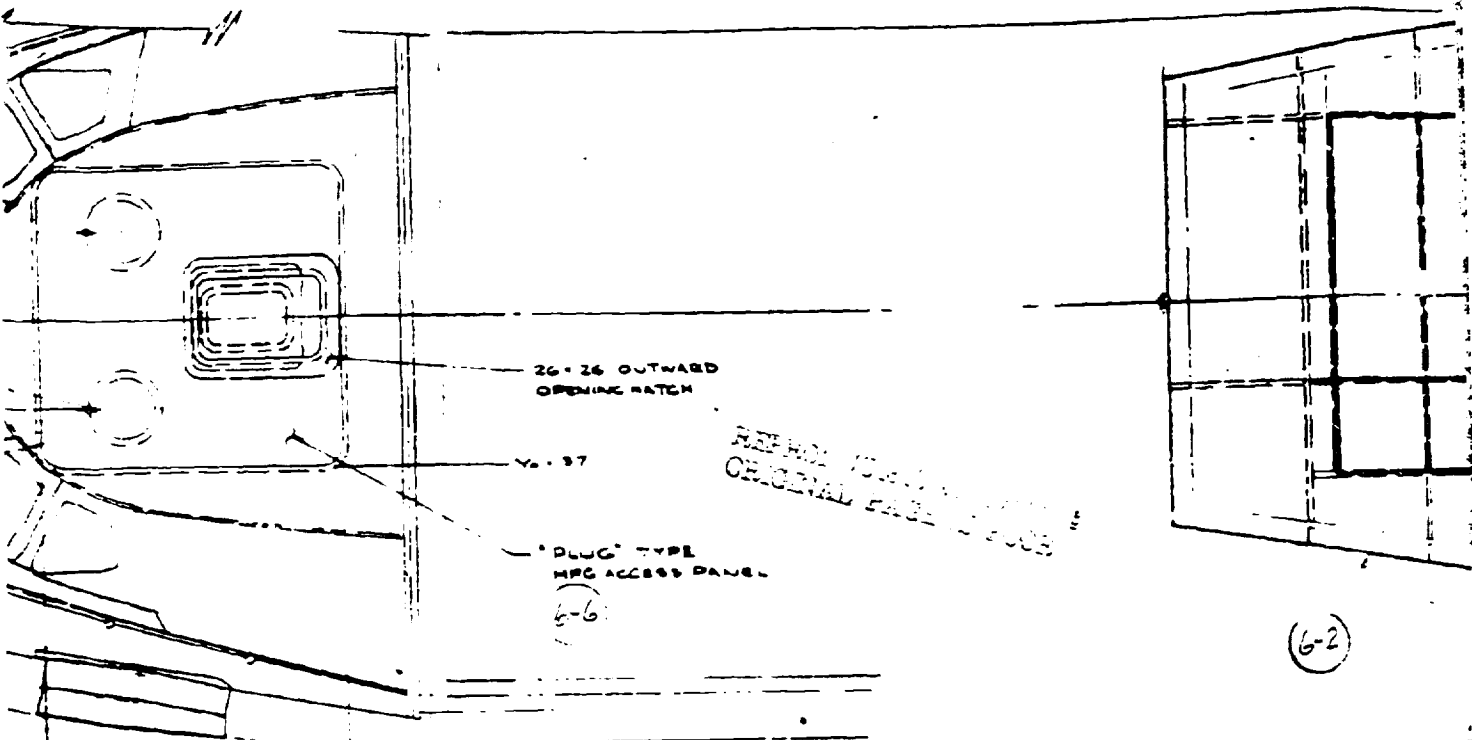

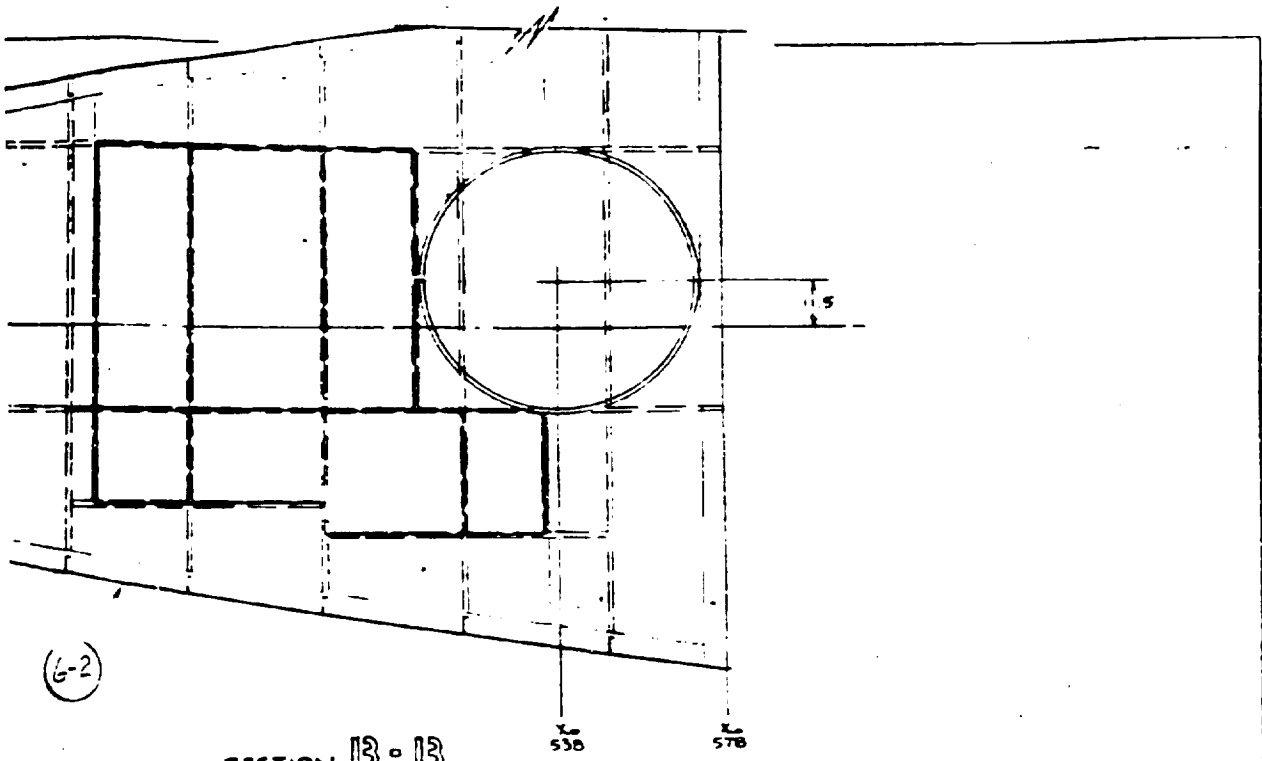

(6-2)

SECTION 13-13

REQUIREMENTS & ASSUMPTIONS:
 1. LINES PER VL70-000143A
 2. INTERIOR ARRANGEMENT PER VL70-000143B

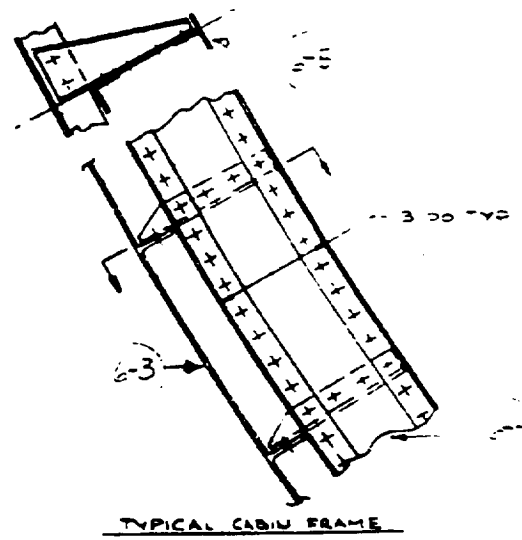
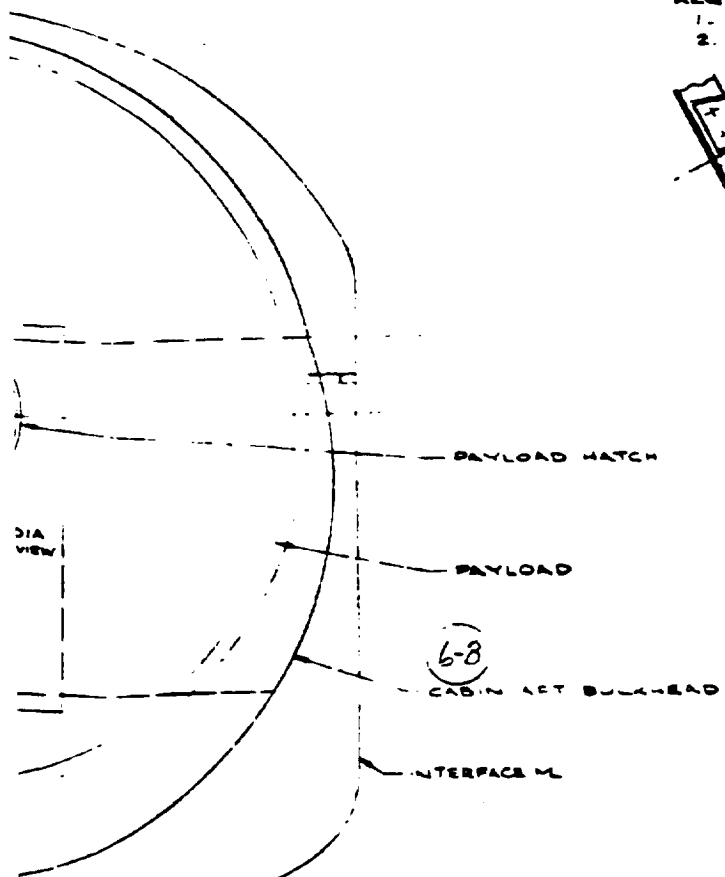

OUT FRAME
 3

Figure 1.6.2. Cabin Structure

REPRODUCIBILITY OF THE ORIGINAL PAGE IS POOR

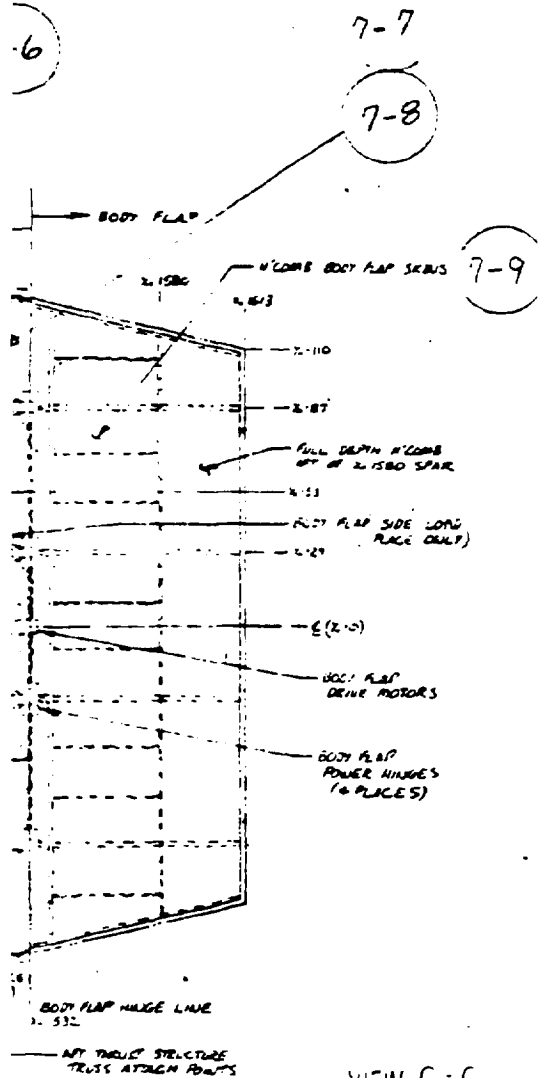

LATERAL TRUSS (RH SIDE ONLY)

VIEW C-C
SCALE 1/20
VIEW LOOKING UP

FRAME

REV. 1997 TRUSS LIGHT SYSTEM
SIZE 1/8" X 1/8" X 1/8"

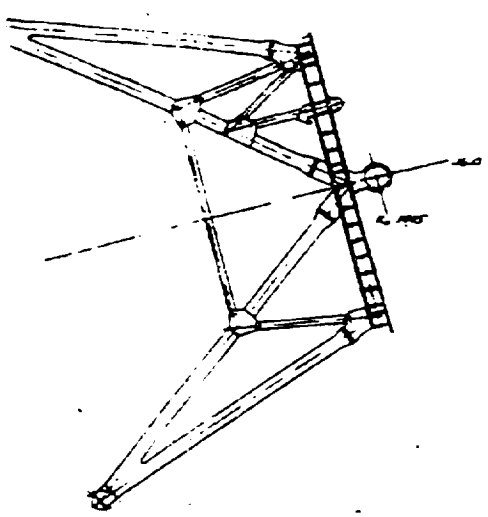

E-E
 THRUST SUPT. STRUCT. TRUSS WORK
 SEE W.D. 005093

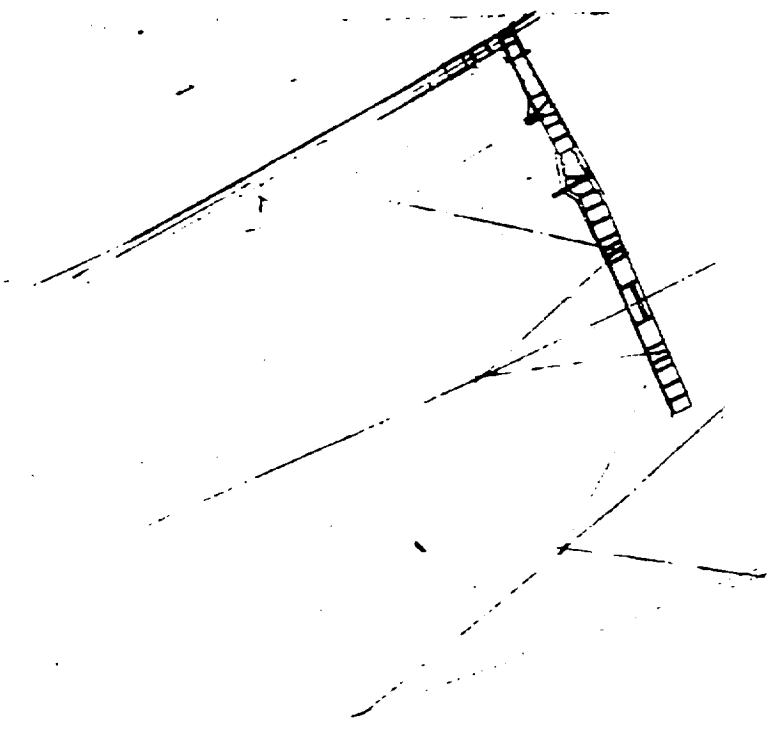

D-D
 VIEW LWR THRUST SUPT. STRUCT. TRUSS WORK
 SEE W.D. 005093

OUT FRAME

3

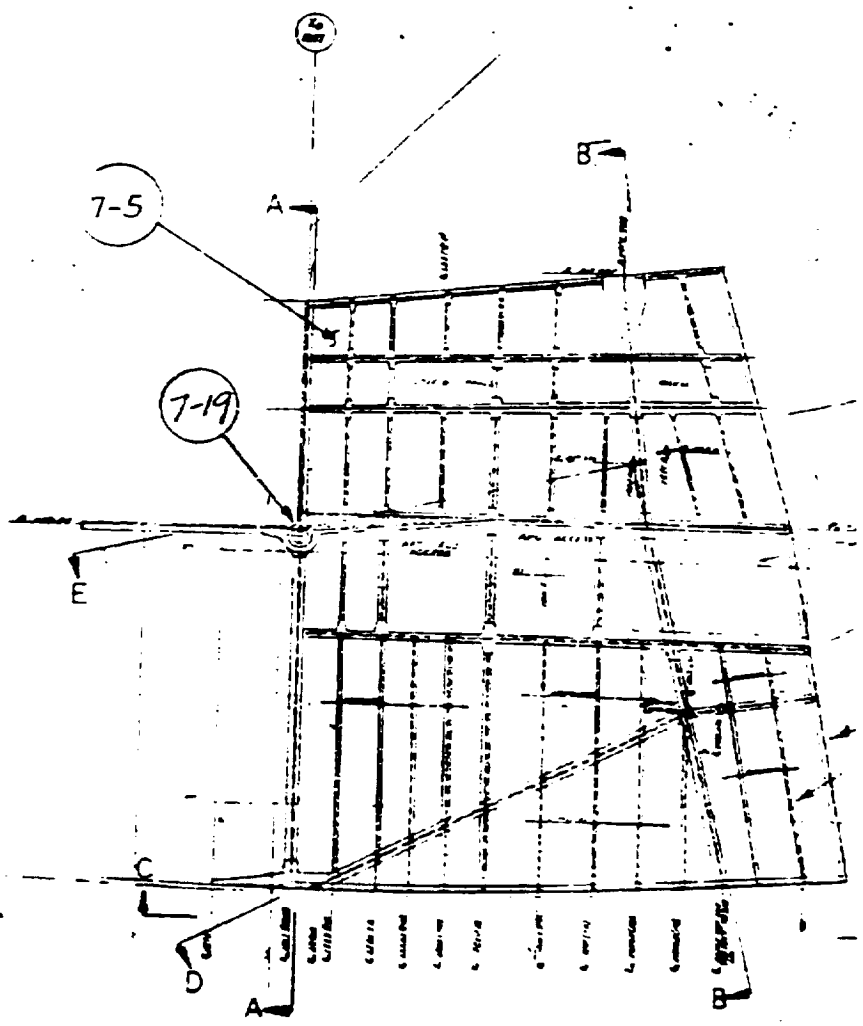
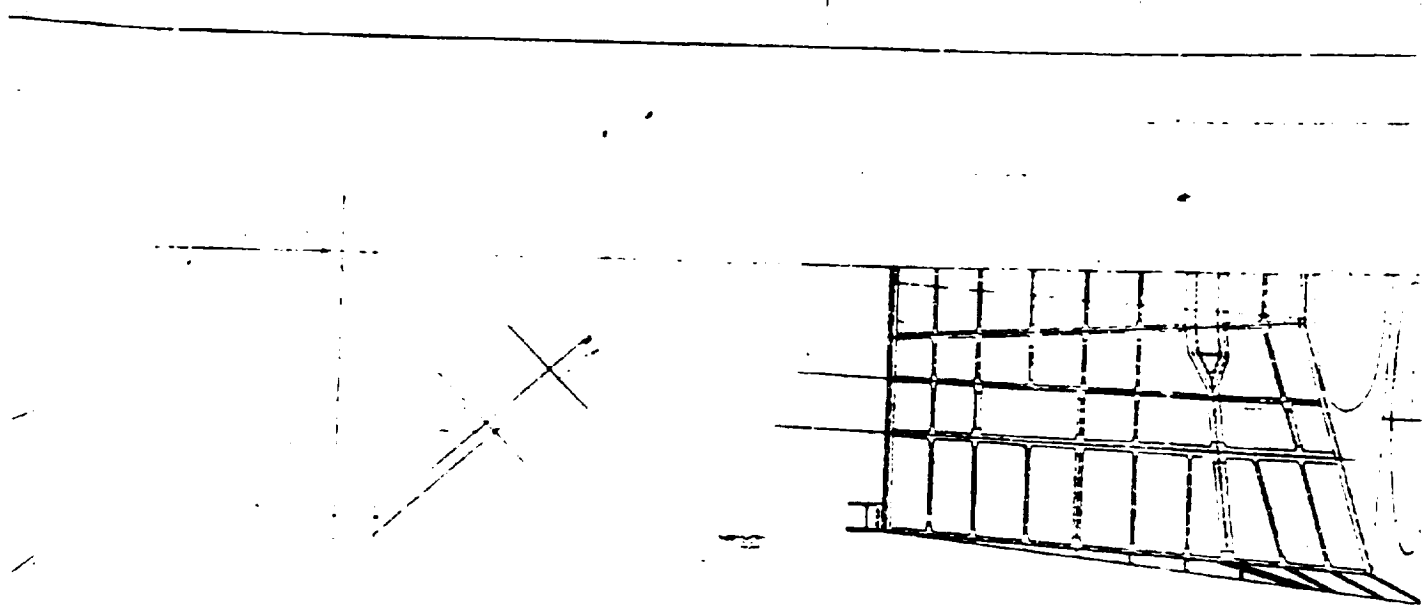

FR. FRAME

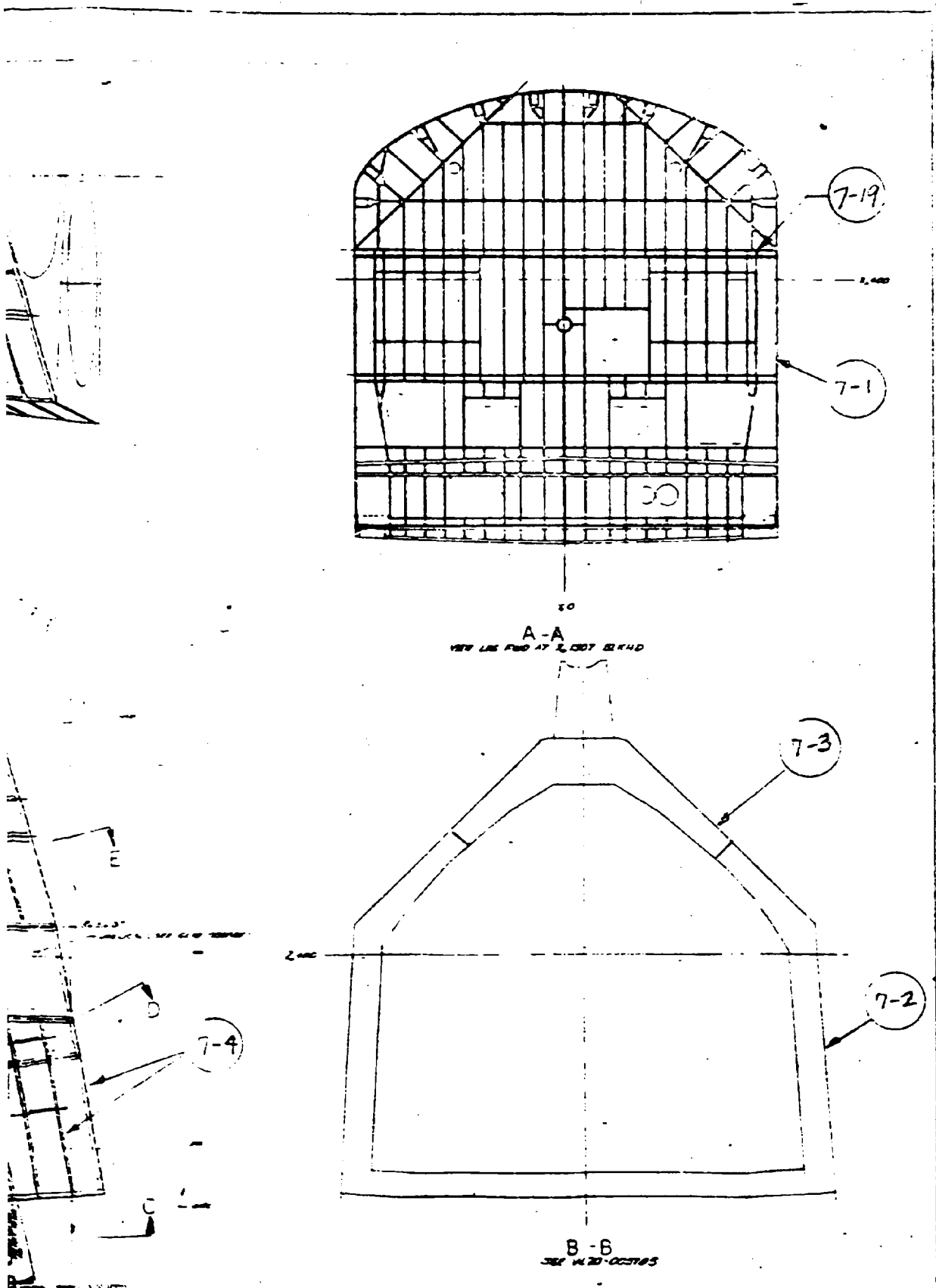

Figure 1.7.1. Aft Fuselage Structural Arrangement

AP 1350

AP 1307

REPRODUCIBILITY OF THE
ORIGINAL PAGE IS POOR

1350

1307

Z-107500

MOLDOUT FRAME

VE70-005073 SHI 6710

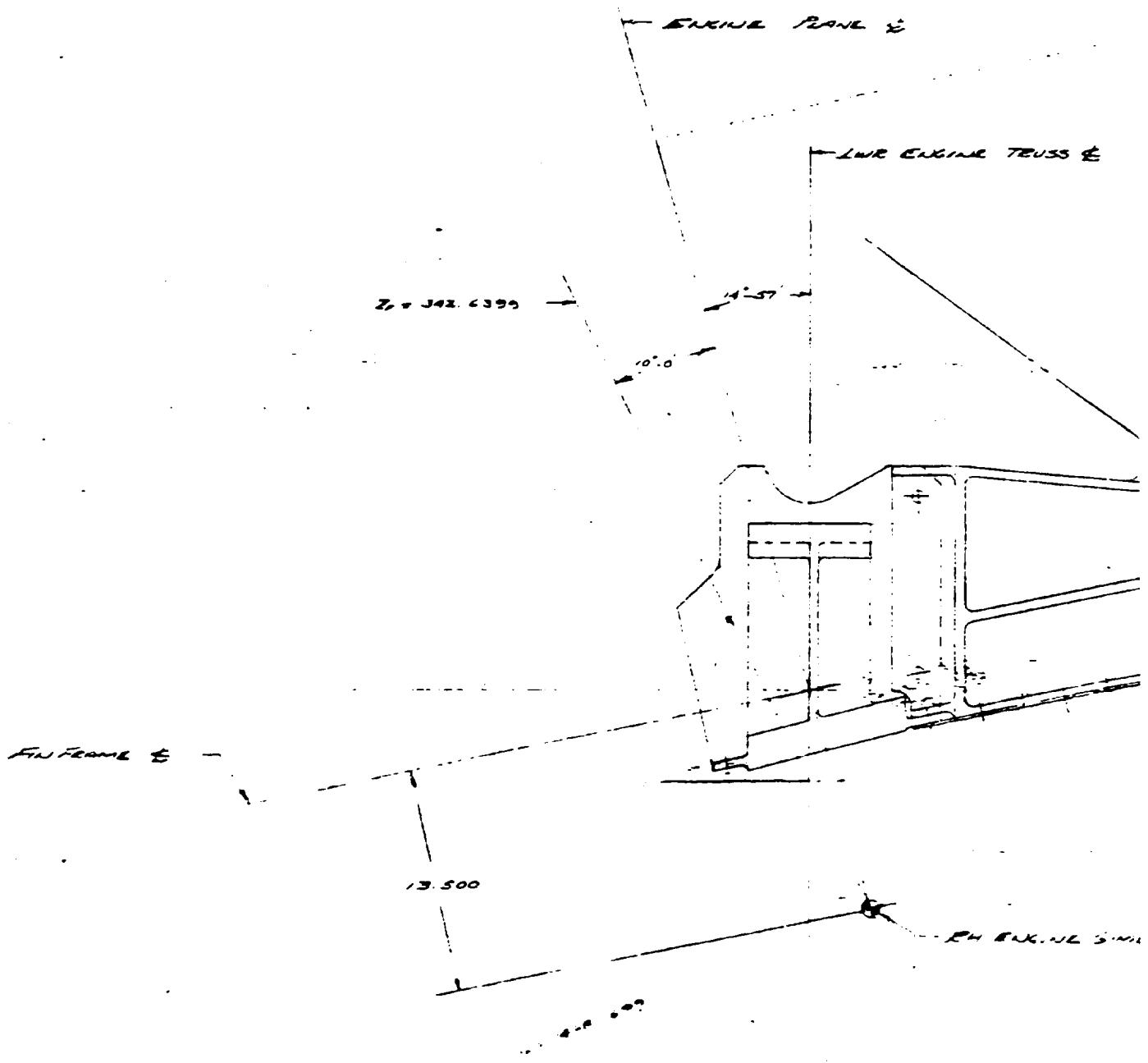
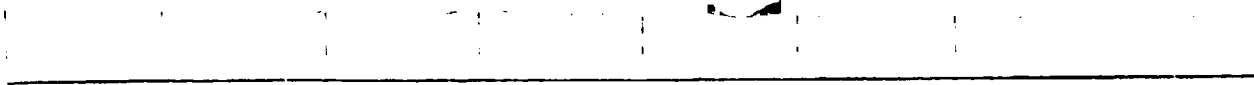

VIEW 4
LWR ENGINE
ACTUATOR

FRAME

VL70-00503 SH I 5/11/00

US FRAME

4475-00-700-I 4 1/2

Z = 209.164

Z = 400.000

UPPER THRUST SHELF

REPRODUCIBILITY OF THE ORIGINAL PAGE IS POOR

BURKHND E $\lambda_e = 1307$

$\lambda_e = 1317$

F

$\approx Z = 267.500$
(DEPENDANT ON FINAL WING CONFIG)

VL

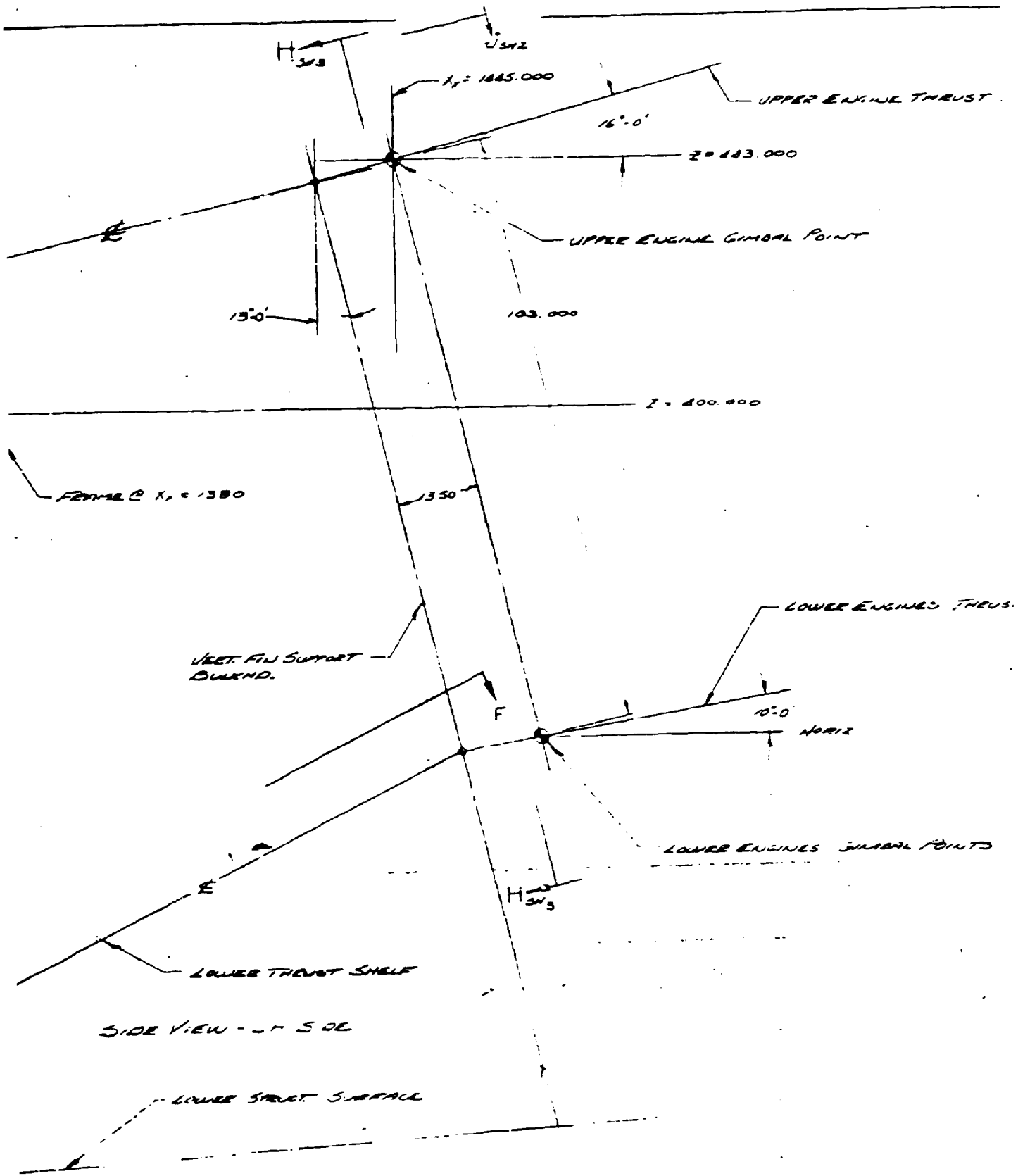

SIDE VIEW - L.S. DE

KINE THRUST LINE

REPRODUCIBILITY OF THE ORIGINAL PAGE IS POOR

ENGINE THRUST LINE

WAL POINTS

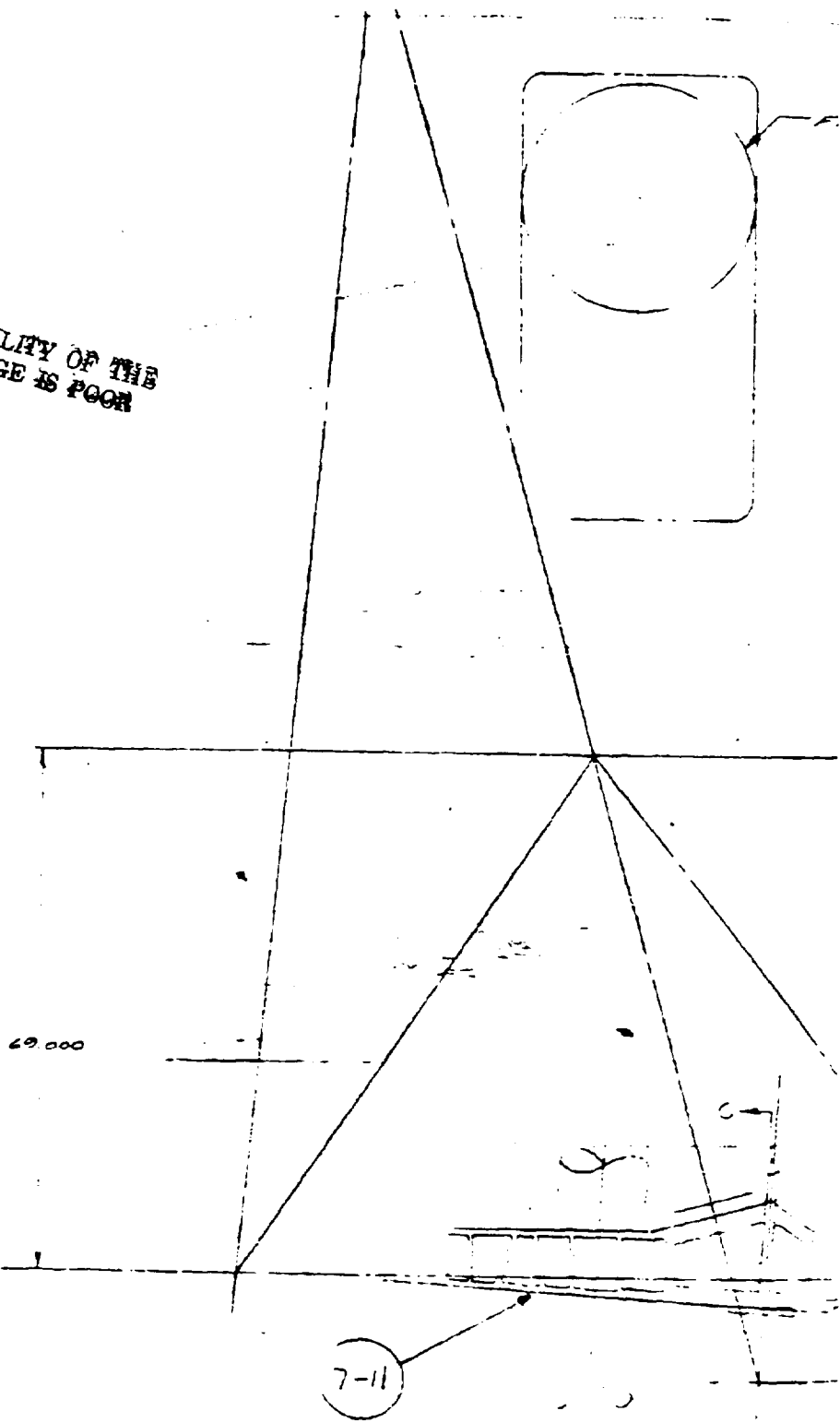

100 PRANT

26 50"

FIELD LINE DISCONNECT

TRAIL SHELF DATUM PLANE
K₀ = 1307.000

REPRODUCIBILITY OF THE ORIGINAL PAGE IS POOR



FWD.

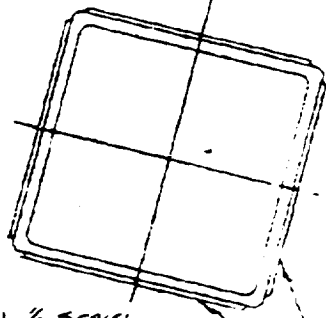

SECTION 1/2 SCALE
SHOWS APPLICATION OF
EPOXY TAPES TO
TOP SIDES OF MEMBERS

BOND EPOXY
TAPES

TEMP 200 IN
50 5 06

FIELD DIRT
AREA

FIELD 2 -
1000

42.708

100

21.4382

21.4382

42.710

65

B

E

E

A

VIEW F-F
FOOTED

VL701 5-93 SH I

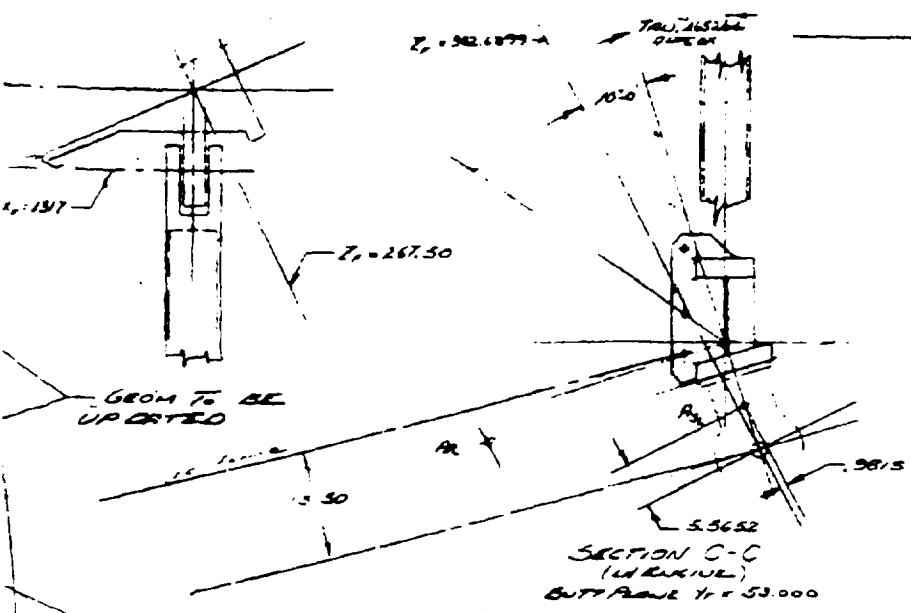

7-15

REPRODUCIBILITY OF THE ORIGINAL PAGE IS POOR

$Z_1 = 32.1777$

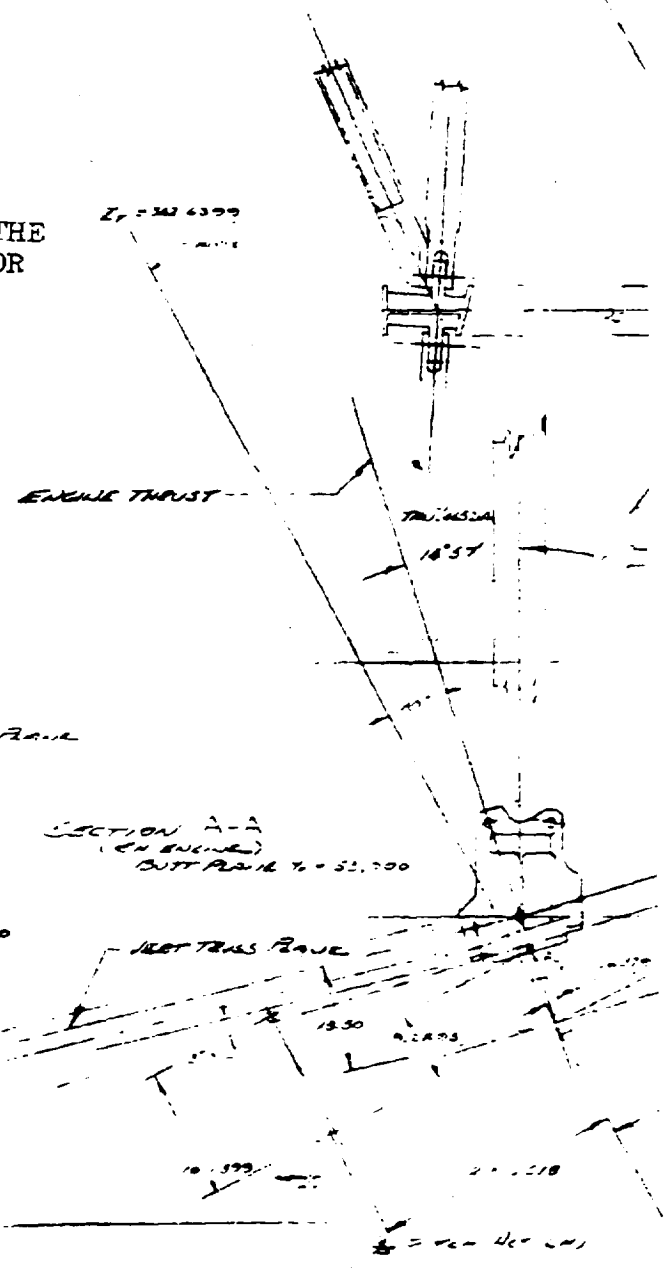
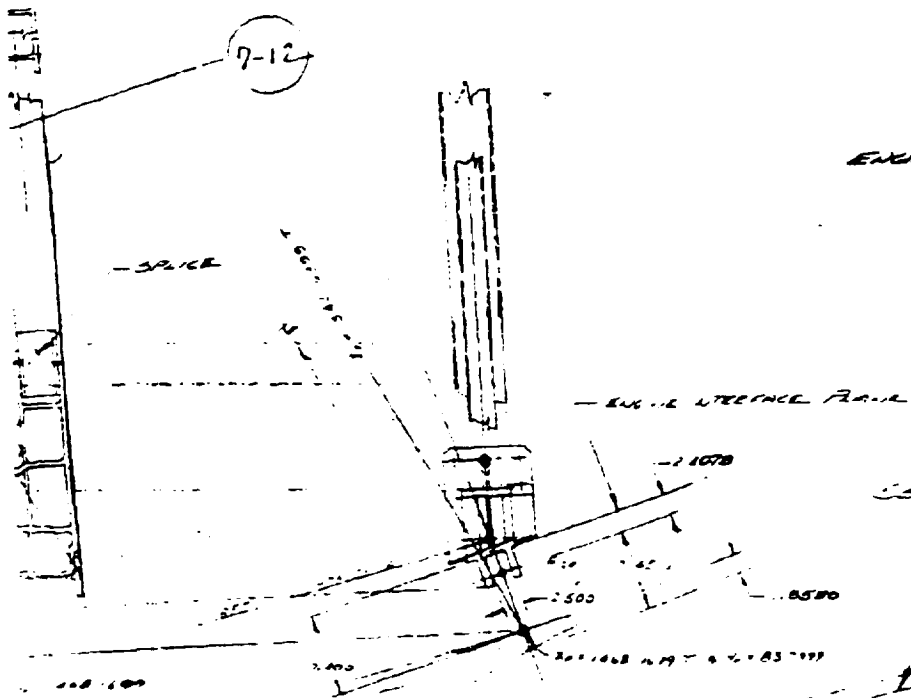

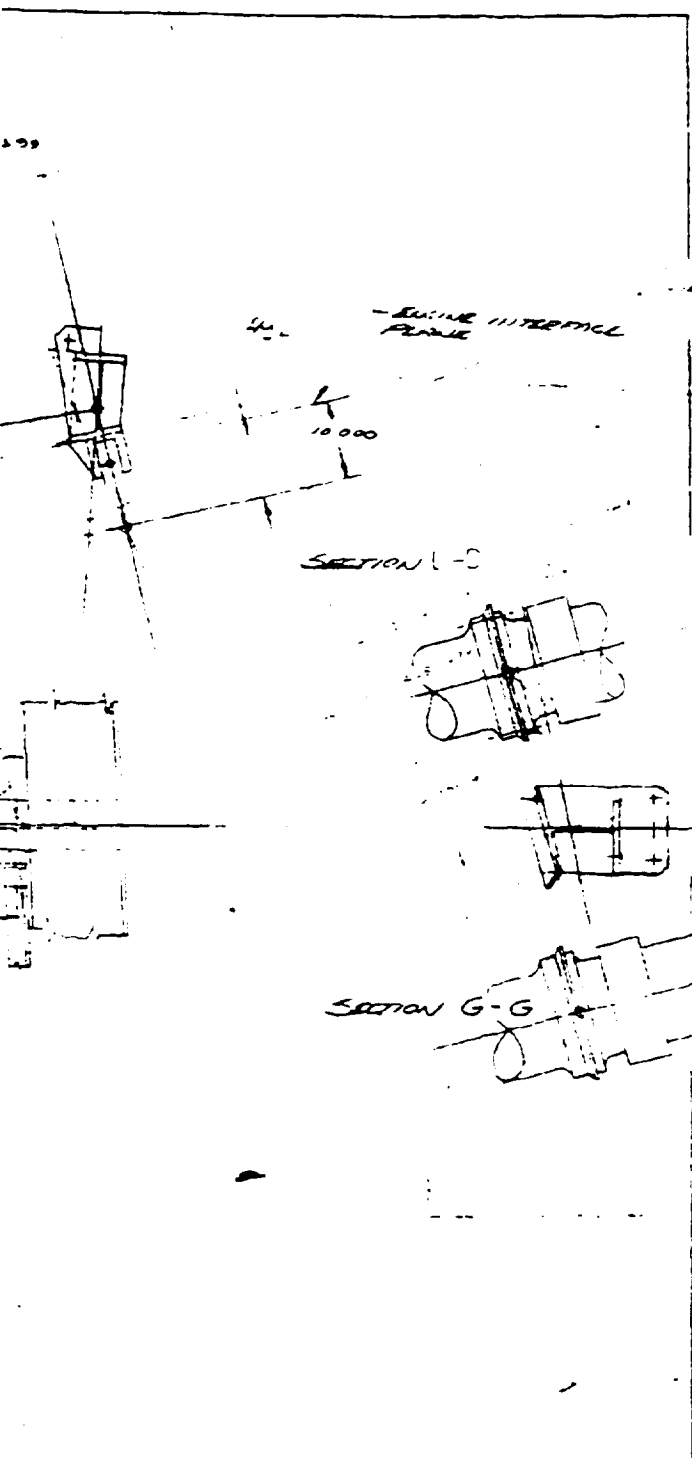

FOLDOUT FRAME

REPRODUCIBILITY OF THE ORIGINAL PAGE IS POOR

2. Main Engine Thrust Support Structure

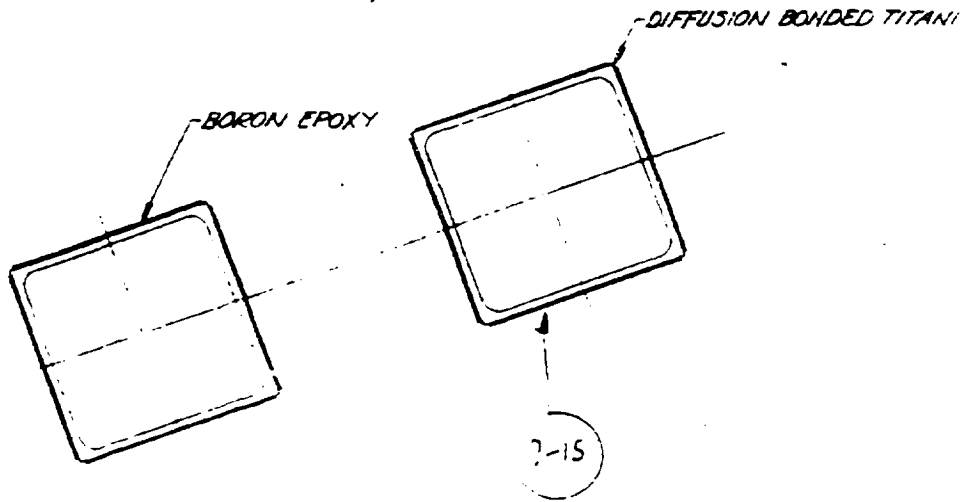

SECT B-B
SCALE 1/2

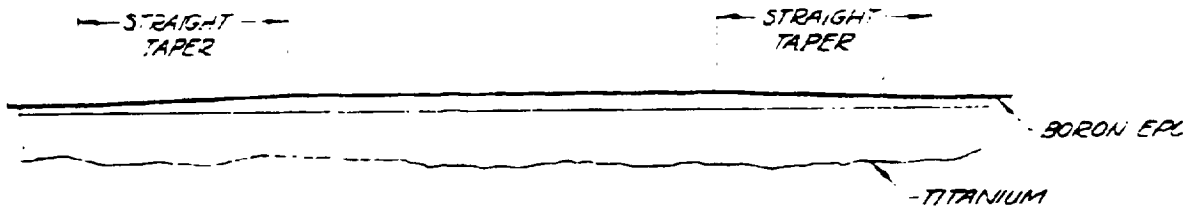

SECT C-C (ROTATED 90°)
SCALE 1/2

REPROD (COPY) OF THE
ORIGINAL PAGE IS FOUR

AME

TANIUM

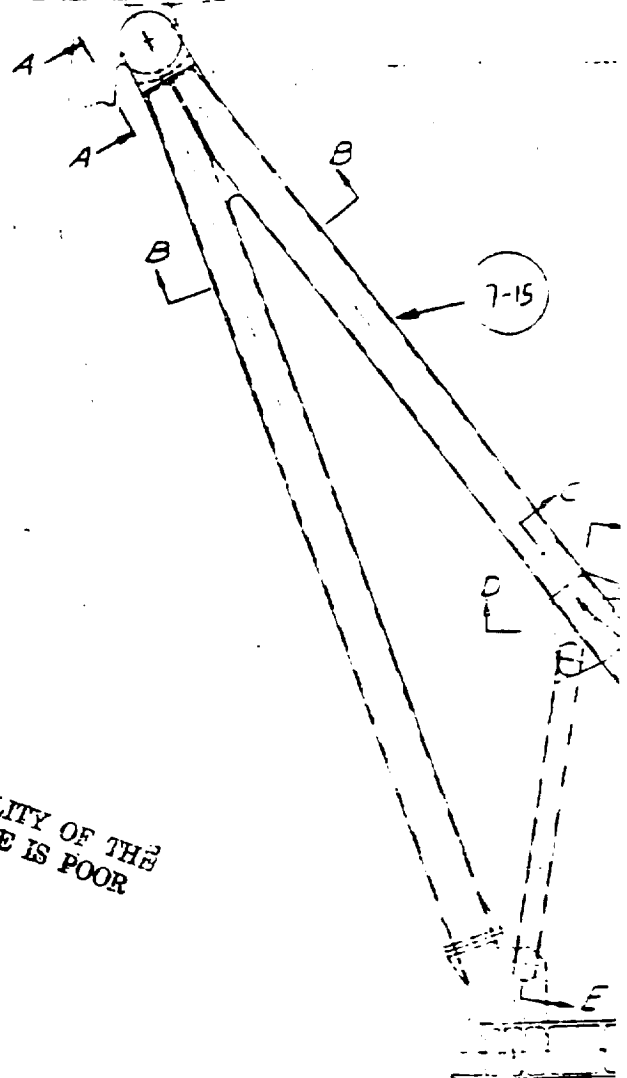

VIEW A-A

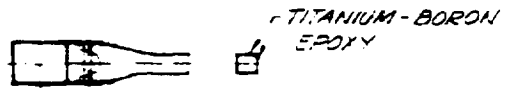

SECT D-D

REPRODUCIBILITY OF THE ORIGINAL PAGE IS POOR

EPOXY

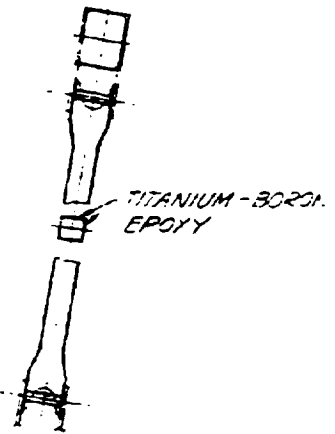

SECT E-E

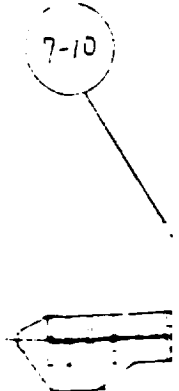

I FRAME

REPRODUCIBILITY OF THE ORIGINAL PAGE IS POOR

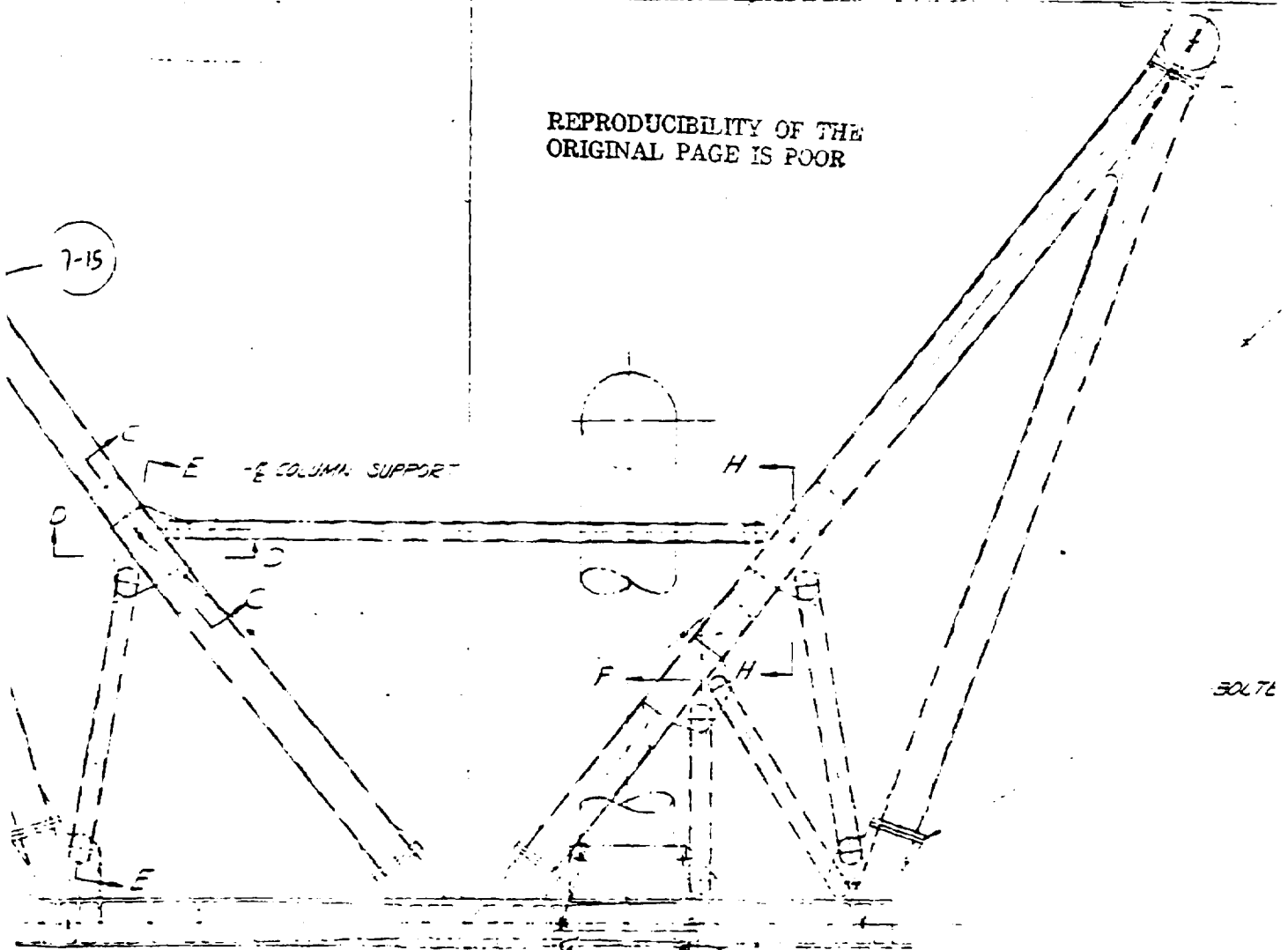

30476

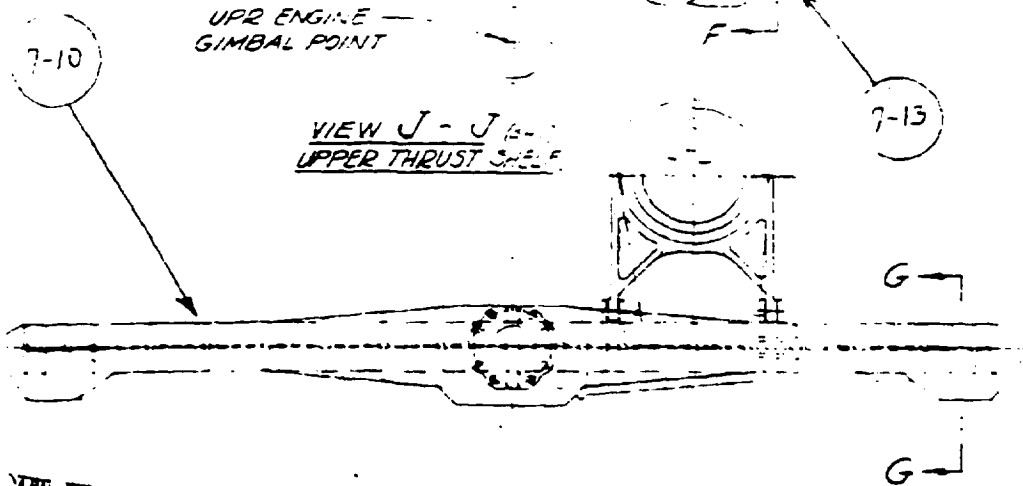

UPR FRAME

30476

TRACE X-1307



ML FUSELAGE AT
UPR THRUST SHELF

COLUMN SUPPLY

SECT H-H (ROTATE)

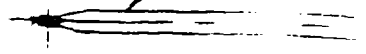

UPPER ML
FUSELAGE

AL ALLOY TUBE

BOLTED FLANGES

BORON EPOXY
TUBES

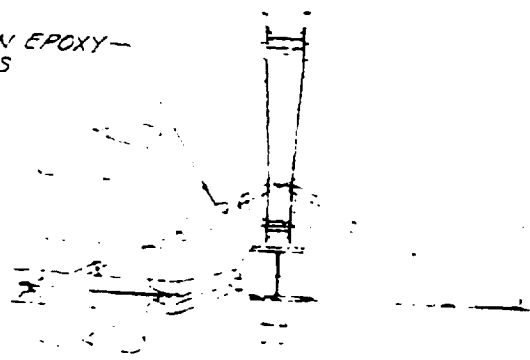

SECT F-F



SECT G-G

4

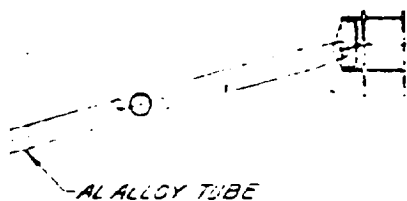
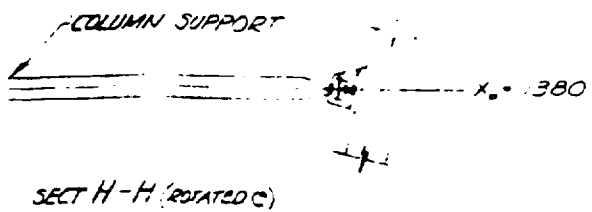

REPRODUCIBILITY OF THE ORIGINAL PAGE IS POOR

FIGURE 1.7.3

Figure 1.7.3. Main Engine Thrust Support Structure

TRACE
2:400
ON LEFT TRUSS PLANE

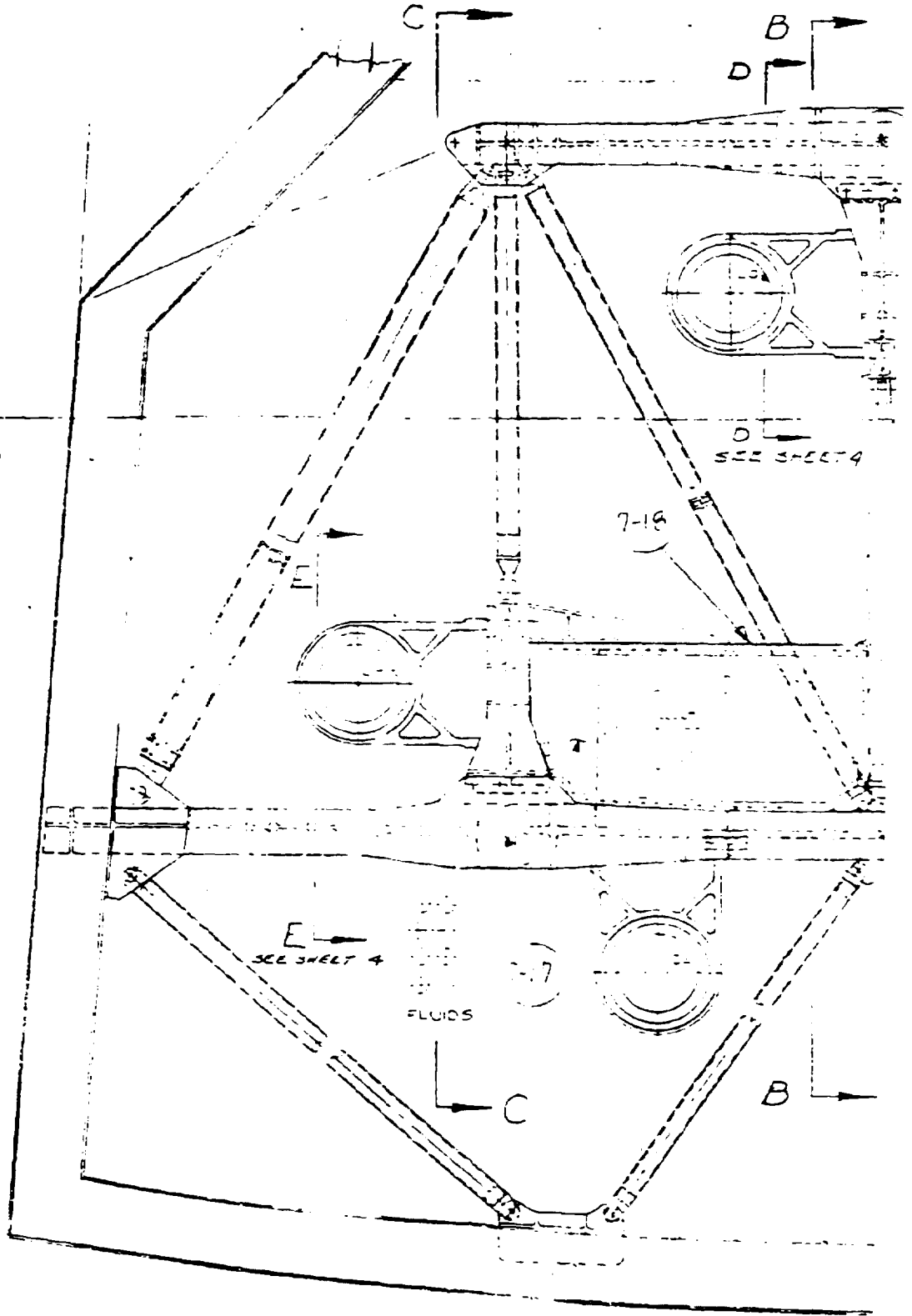

REPRODUCIBILITY OF THE
ORIGINAL PAGE IS POOR

OLDOUT FRAME

V4 70-005093 SH. 3 3193

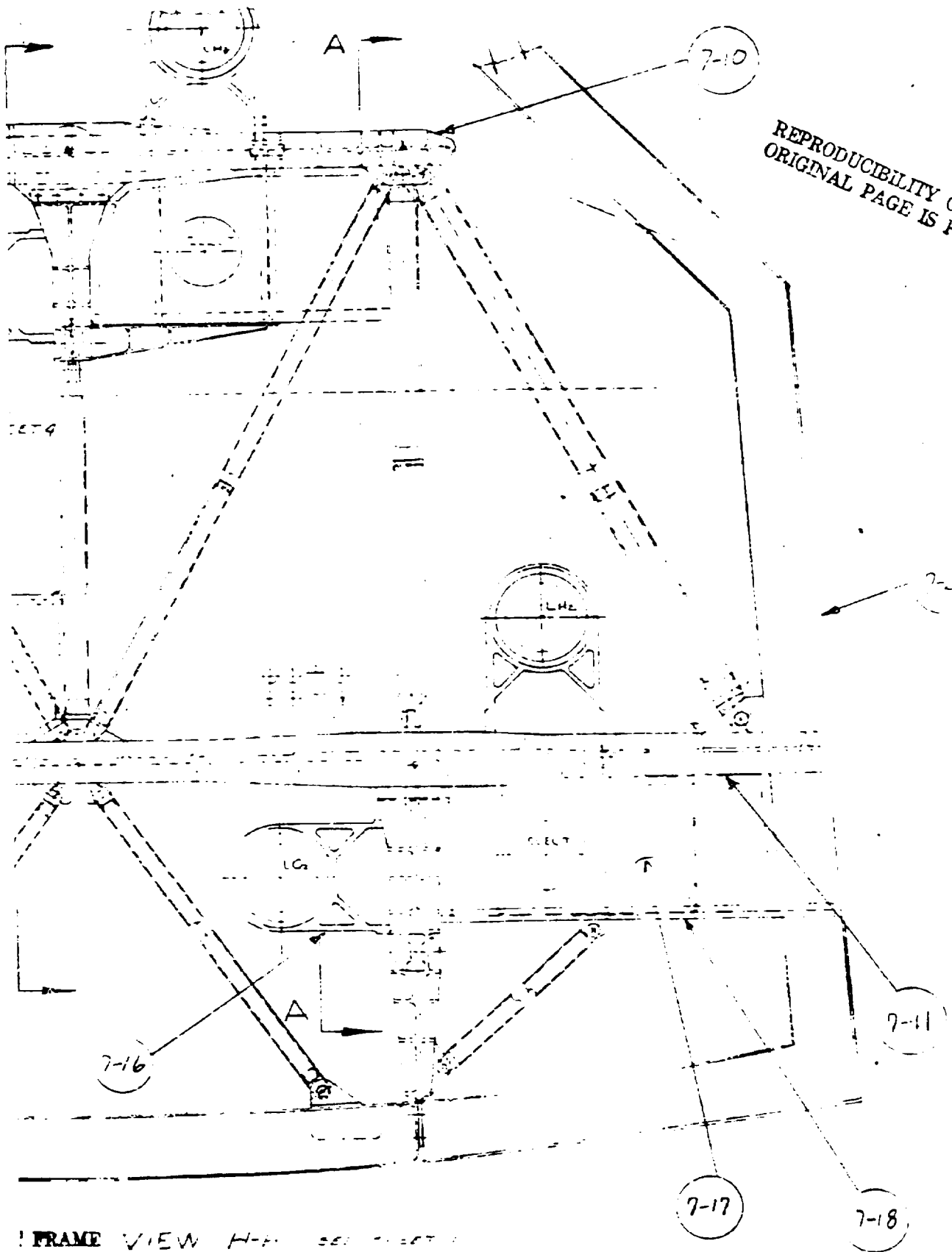

REPRODUCIBILITY OF THE ORIGINAL PAGE IS POOR

TYPICAL
 GALVANIZED
 STEEL
 TUBES
 SURF
 MECH

FRAME VIEW H-H SEE SHEET 1
 TRUE VIEW OF HORIZONTAL TUBES

TY OF THE
IS POOR



BORON/EPOXY TAPES



7-12



7-4

TYPICAL TRUSS MEMBER
SALVAGED FROM EXISTING
TITANIUM BORON/EPOXY
TAPES APPLIED TO OUTER
SURFACES. ONE END FITS
MECHANICALLY FASTENED
SCALE 1/4

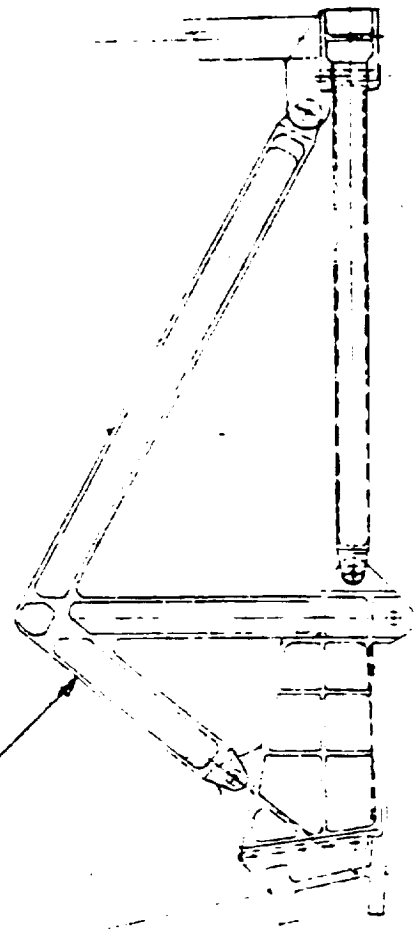

7-19

REPRODUCIBILITY OF THIS
ORIGINAL PAGE IS POOR

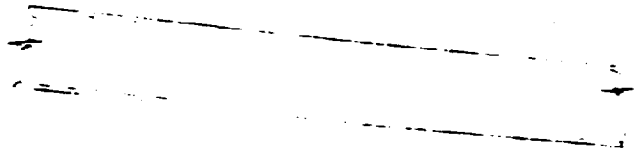

SECTION C-C

CUT FROM

3

VL70-0-5093 SH. 3

20

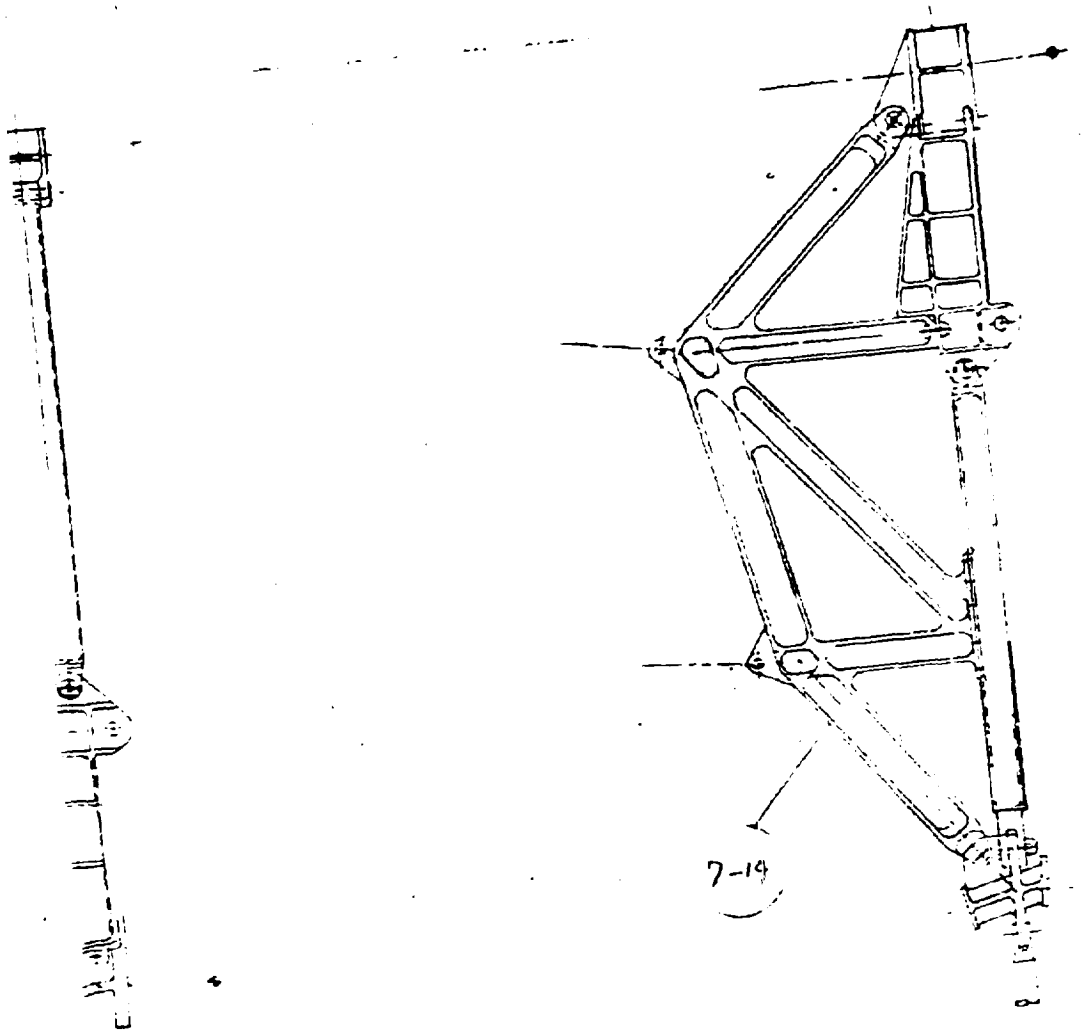

REPRODUCTION OF THE ORIGINAL PAGE IN BLUE

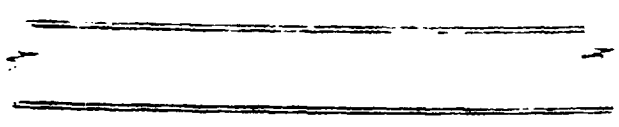

SECTION B-E

WELDOUT FRAME
 C-C 4
 203

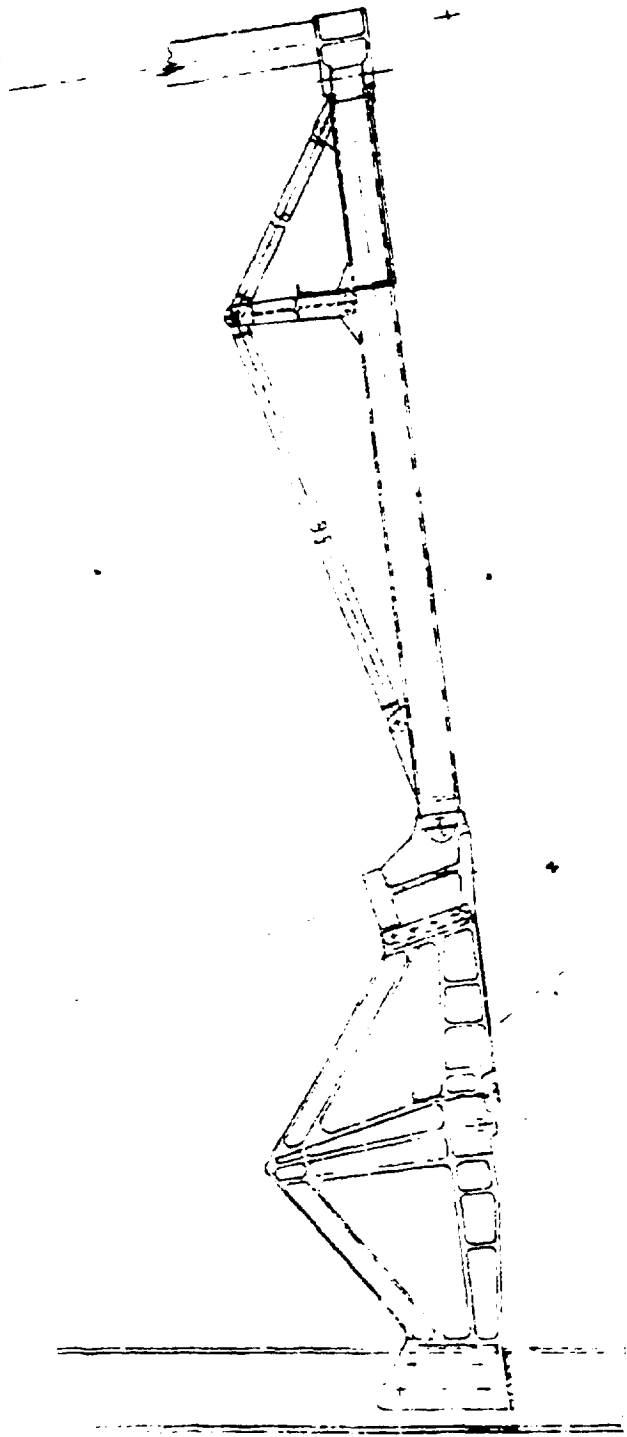

SECTION A-A

Figure 1.7.4. Main Engine Thrust Support

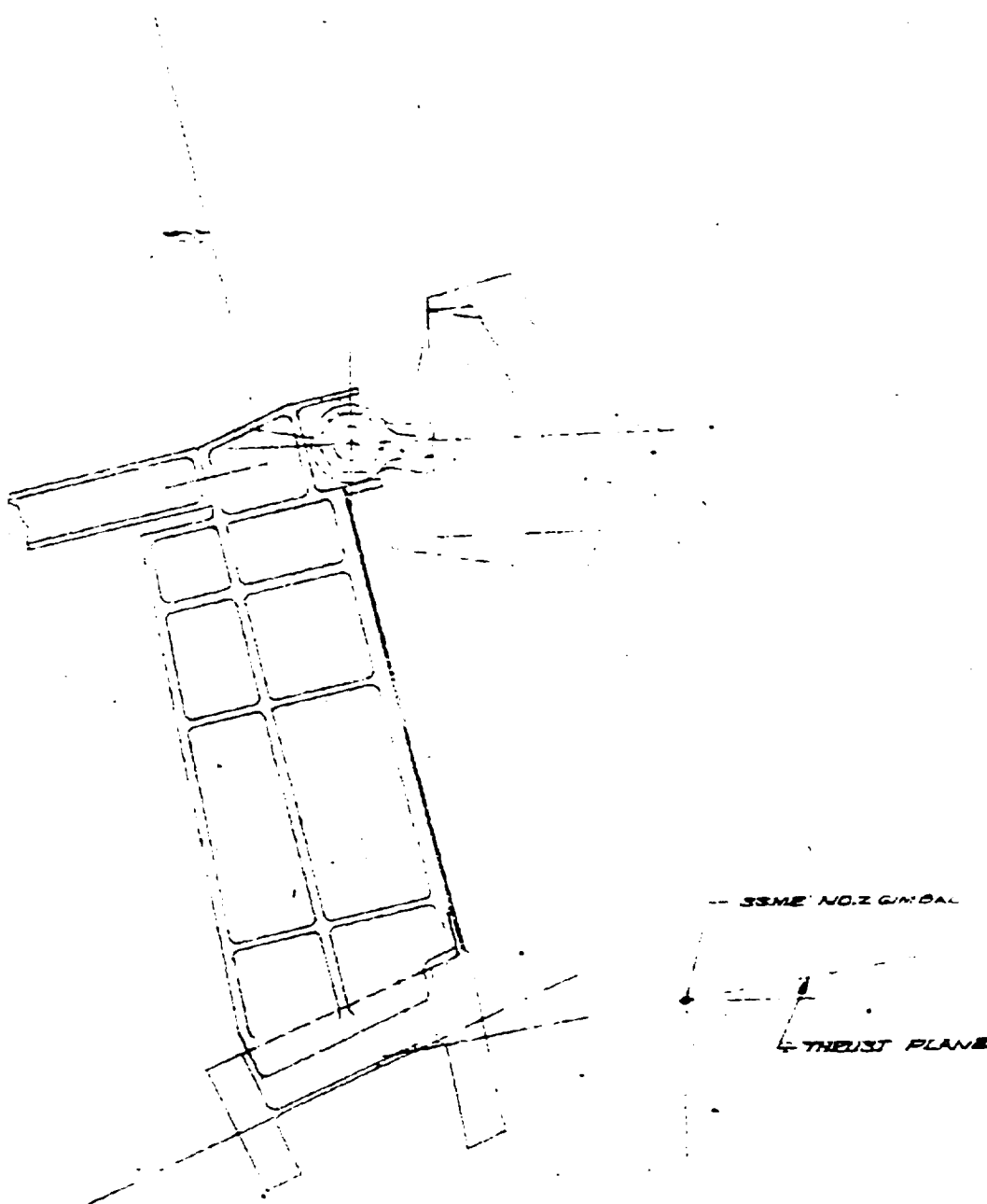

PRODUCIBILITY OF THE ORIGINAL PAGE IS POOR

SECTION 100 100 SHIT 3 SCALE 1/4
 VIEW LKG INCD AT PITCH ACTUATOR SUPPORT
 STRUCTURE FOR SSME NO 2 (LWR LH)

OUT FRAME

4470-005093 SH. 4. 3 (M) 3

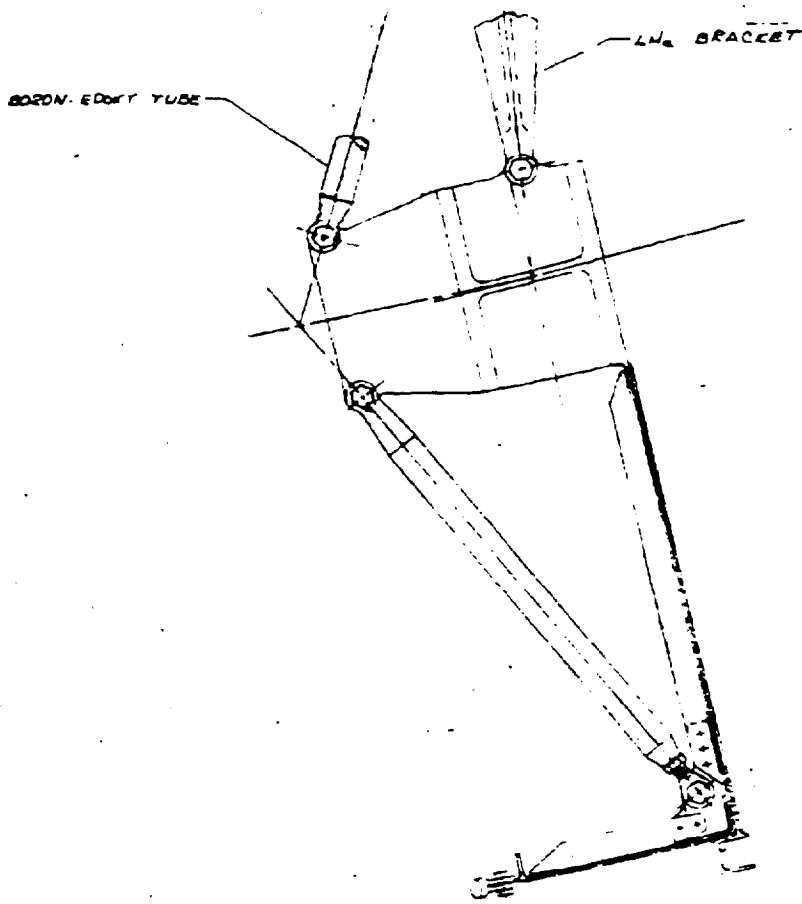

7-19

SECTION 13-13 SCALE: 1/2

REPRODUCIBILITY OF THE ORIGINAL PAGE IS POOR

UMBAL

PLANE 334E 2 43

ADOUT FRAME

43

44

SSME NO. 1 INTERFACE PLANE

SSME

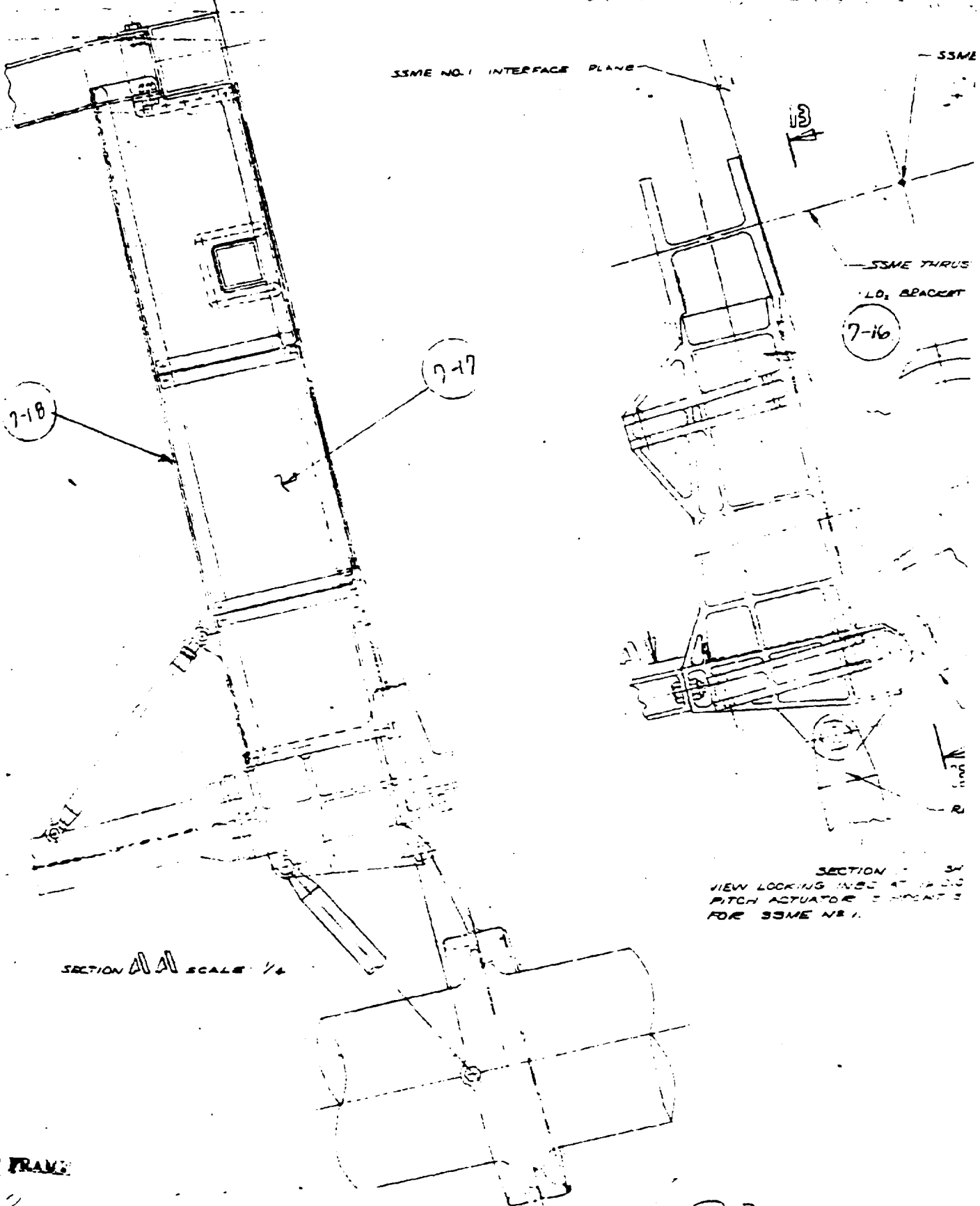

SSME THRU

LO. BRACKET

7-16

7-18

7-17

SECTION A-A
VIEW LOOKING IN AS AT THE
PITCH ACTUATOR ELEMENTS
FOR SSME NO. 1.

SECTION A-A SCALE 1/4

U2 FRAME

VL70-005093 SH. 4

2 (1) 3 1

- SSME NO. 1 GIMBAL

THRUST PLANE

ORBIT

BLEED OUTPUT

- SSME NO. 1 PITCH ACTUATOR

ACTUATOR POS. WITH ENG. NO. 1
GIMBALED 9° YAW, 11° PITCH

SECTION 13-13 SCALE: 1/4

- REF PLANE - VERT SPT STRUCTURE

SPT 5 SCALE 1/4
NO DRAWING
STRUCTURE

FRONT

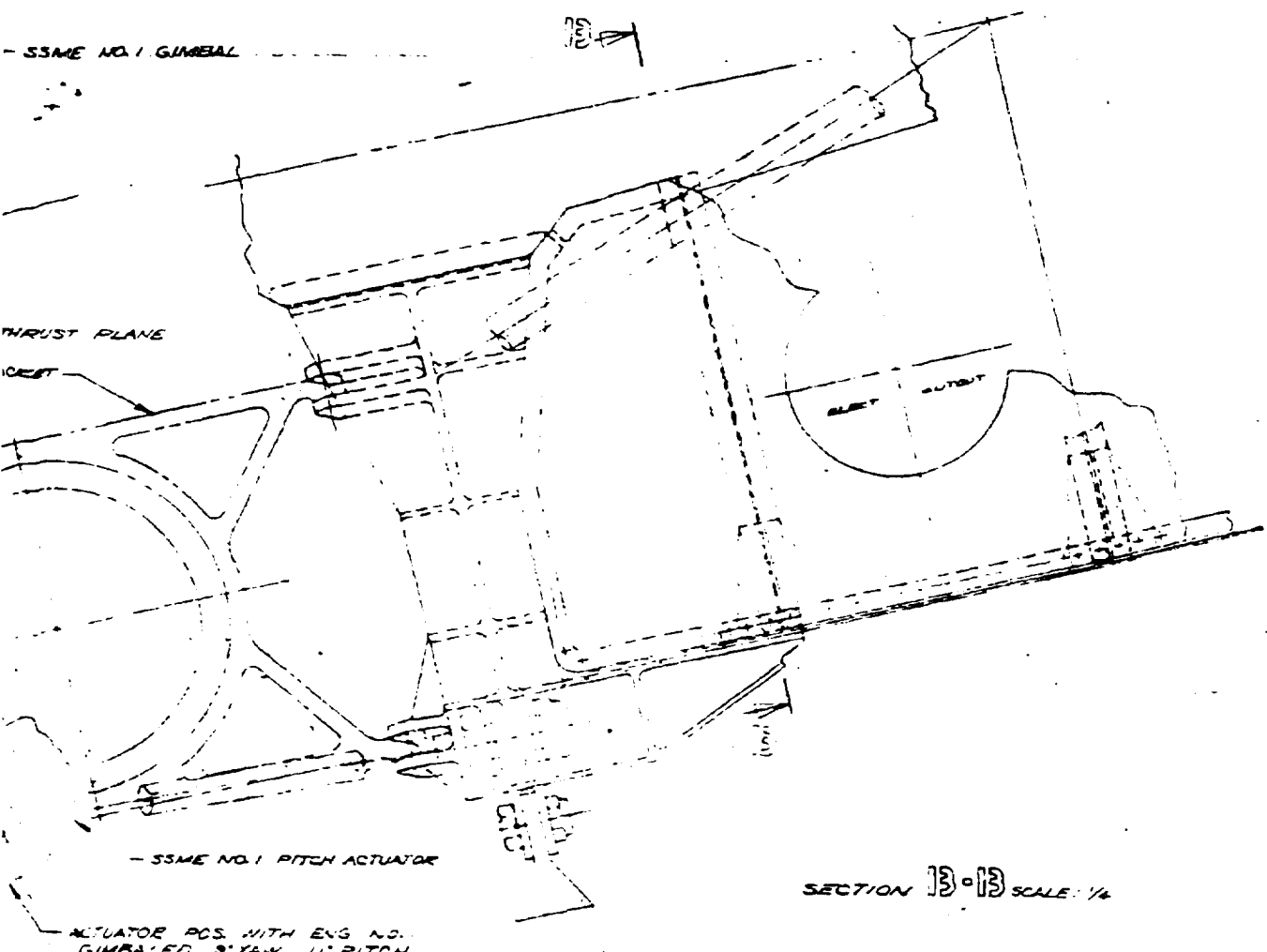

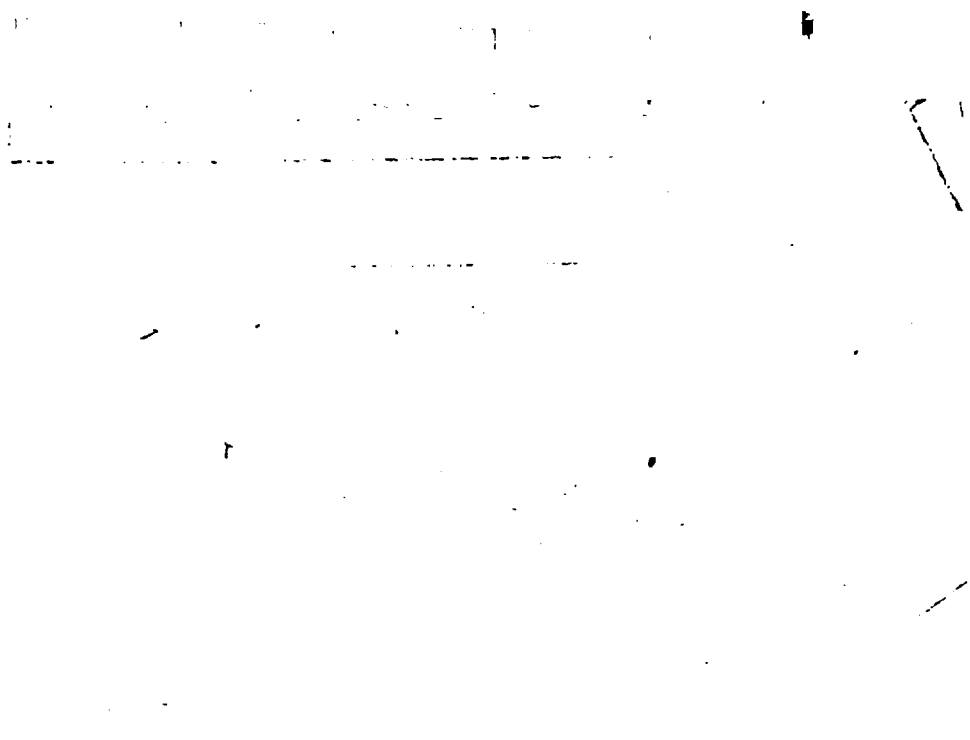

OUTLET FRAMES

Figure 1.7.5. Main Engine Thrust Support Structure

THEORETICAL FLOOR LINE
REMOVABLE COVER FOR F.U. LIGHT

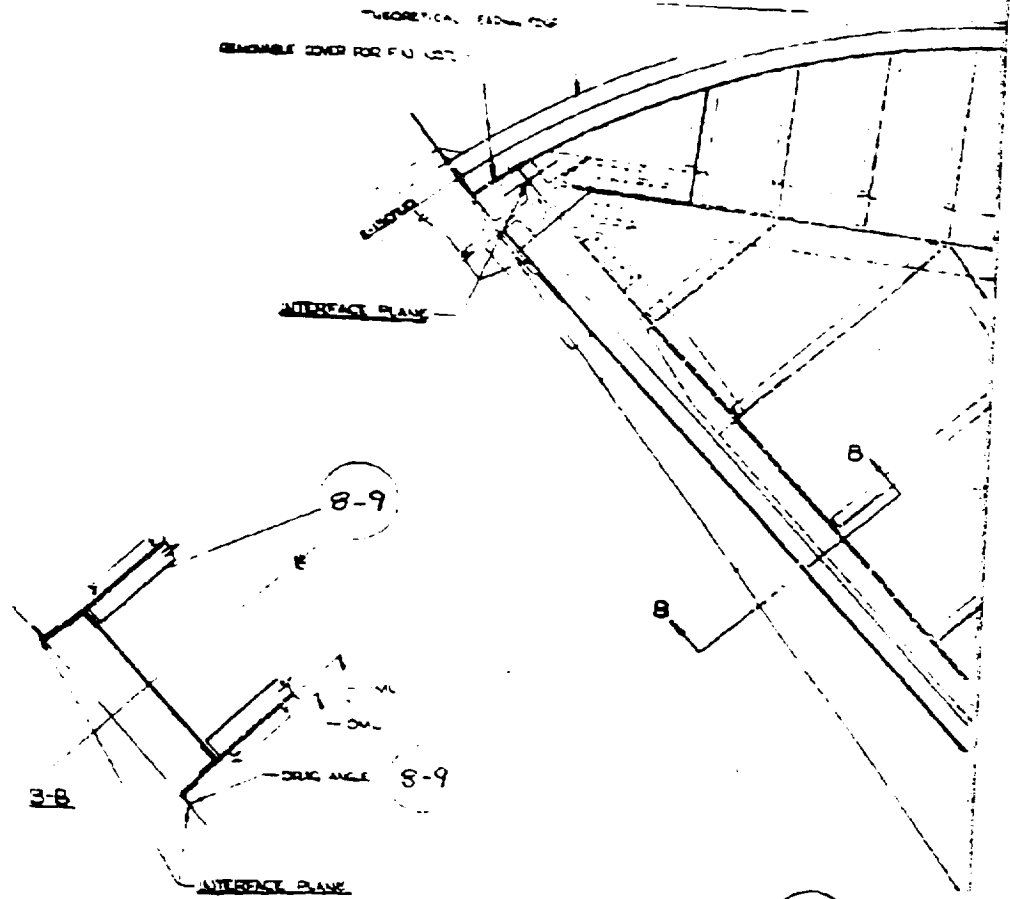

REPRODUCIBILITY OF THE ORIGINAL PAGE IS POOR

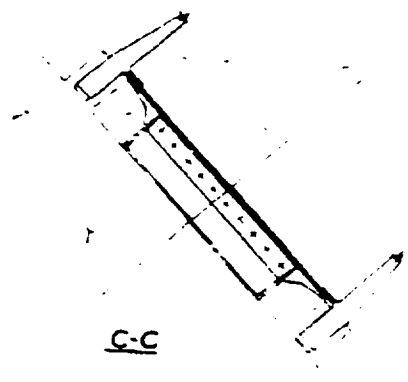
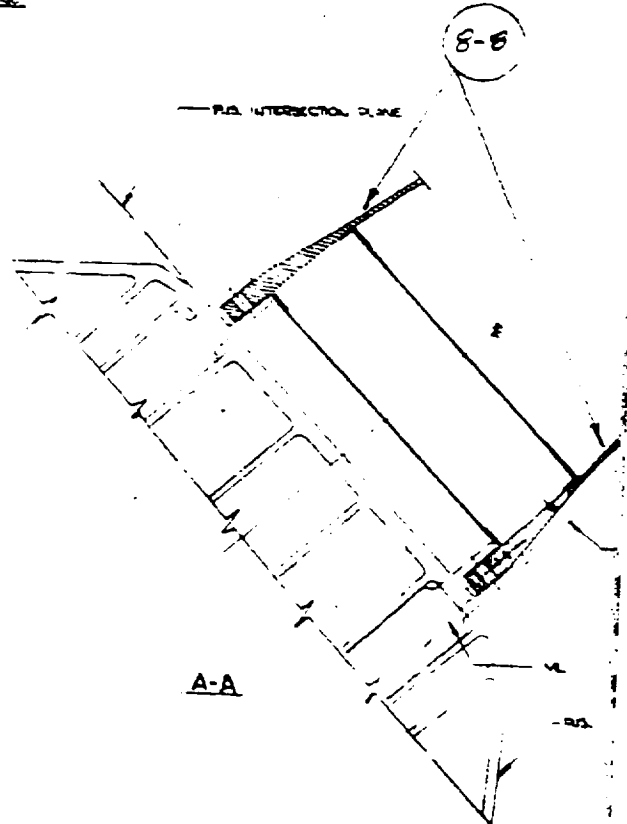

OUT FRAME

C-C

A-A

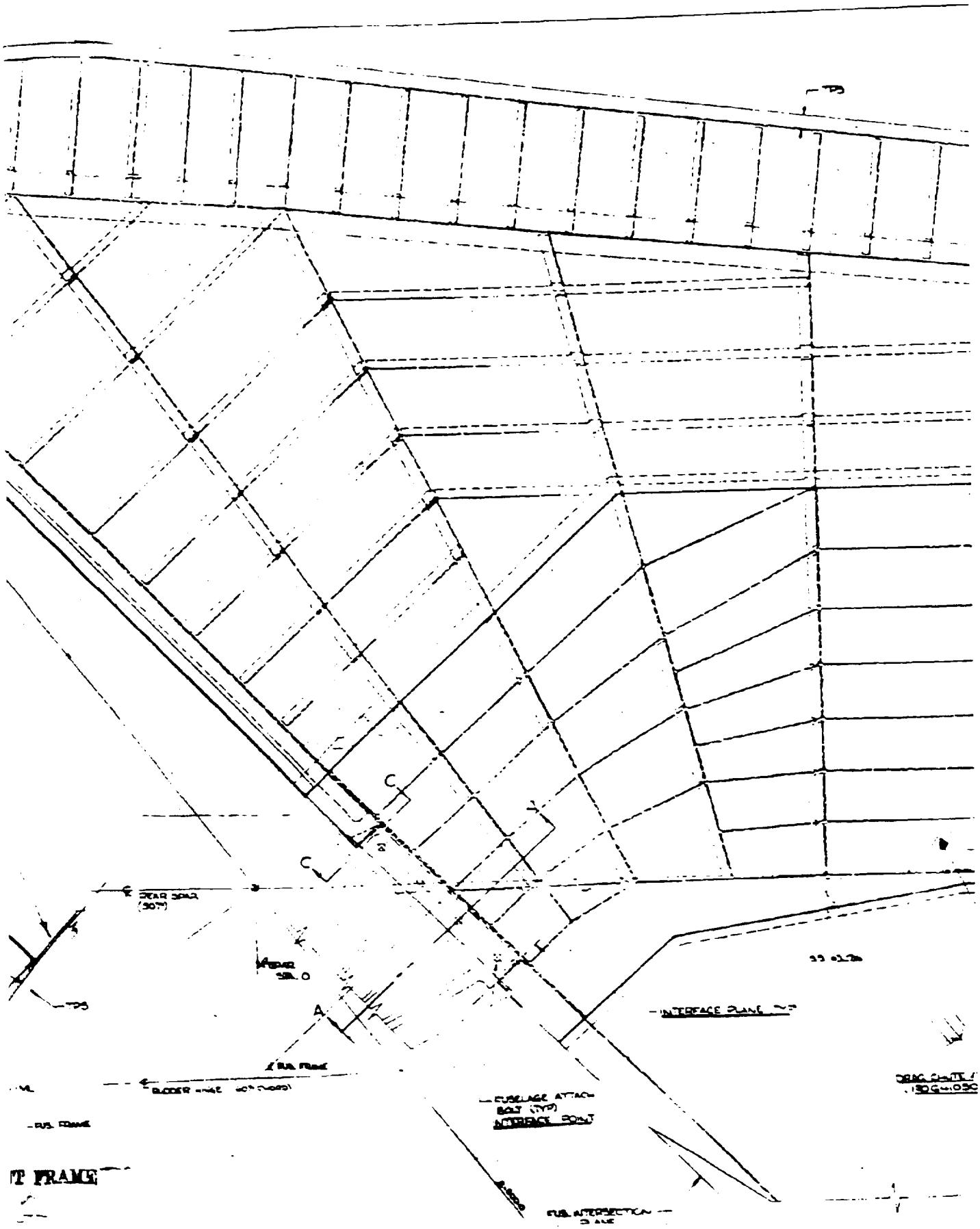

FUS. FRAME

INTERFACE PLANE

FUSELAGE ATTACH BOLT (TYP)
INTERFERENCE POINT

ORIG. DATE: 1206-0300

FUS. INTERSECTION

FIGURE 100 - E. 455

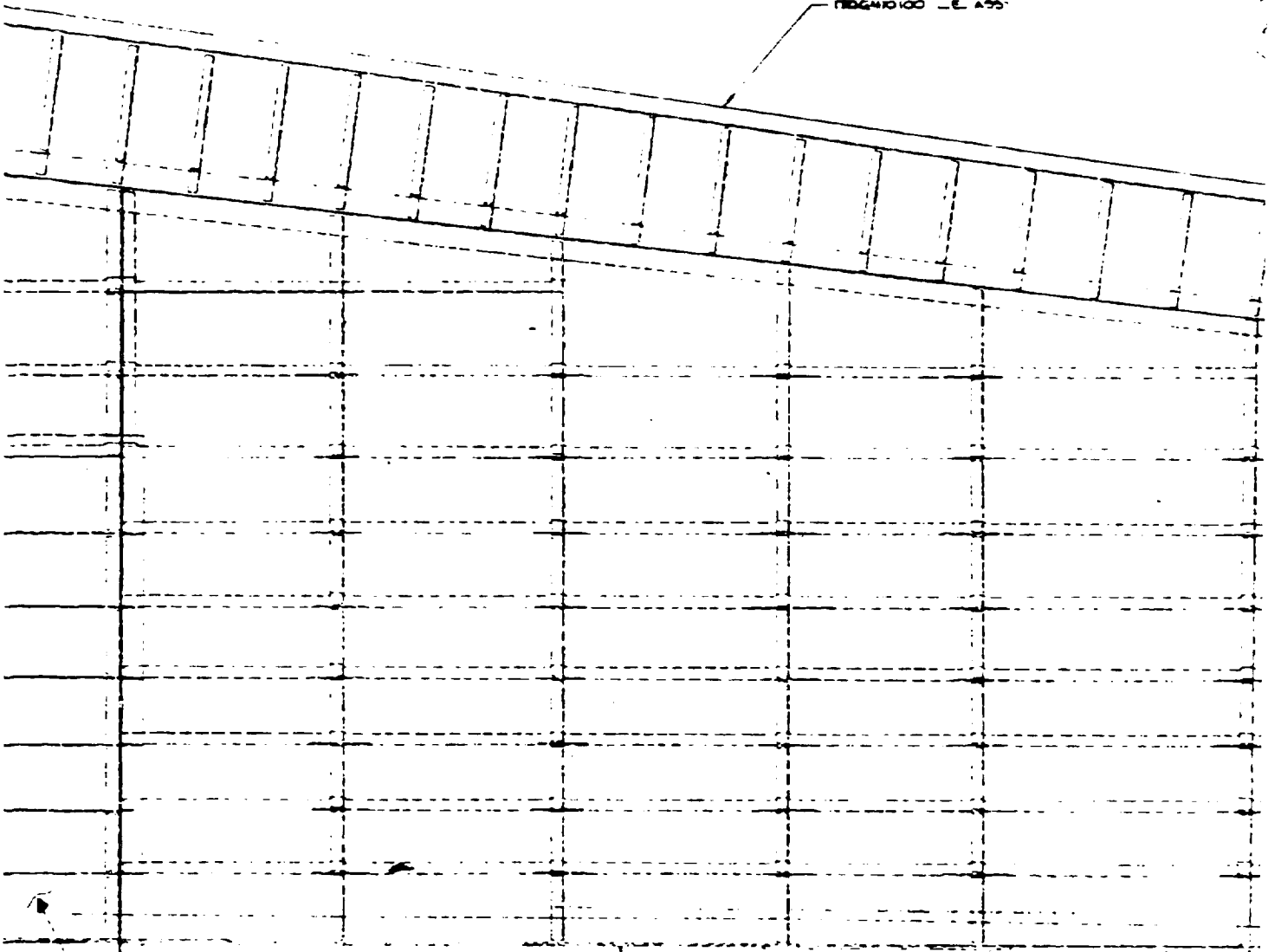

8-8

8-10

8-7

BOAT FRAMES

RUDDER ACTUATOR (NO. 100)

LOWER EDGE OF RUDDER

REPRODUCIBILITY OF THE ORIGINAL PAGE IS POOR

8-5

SPAR CAP

8-6

SPAR WEB

8-4

RIB W

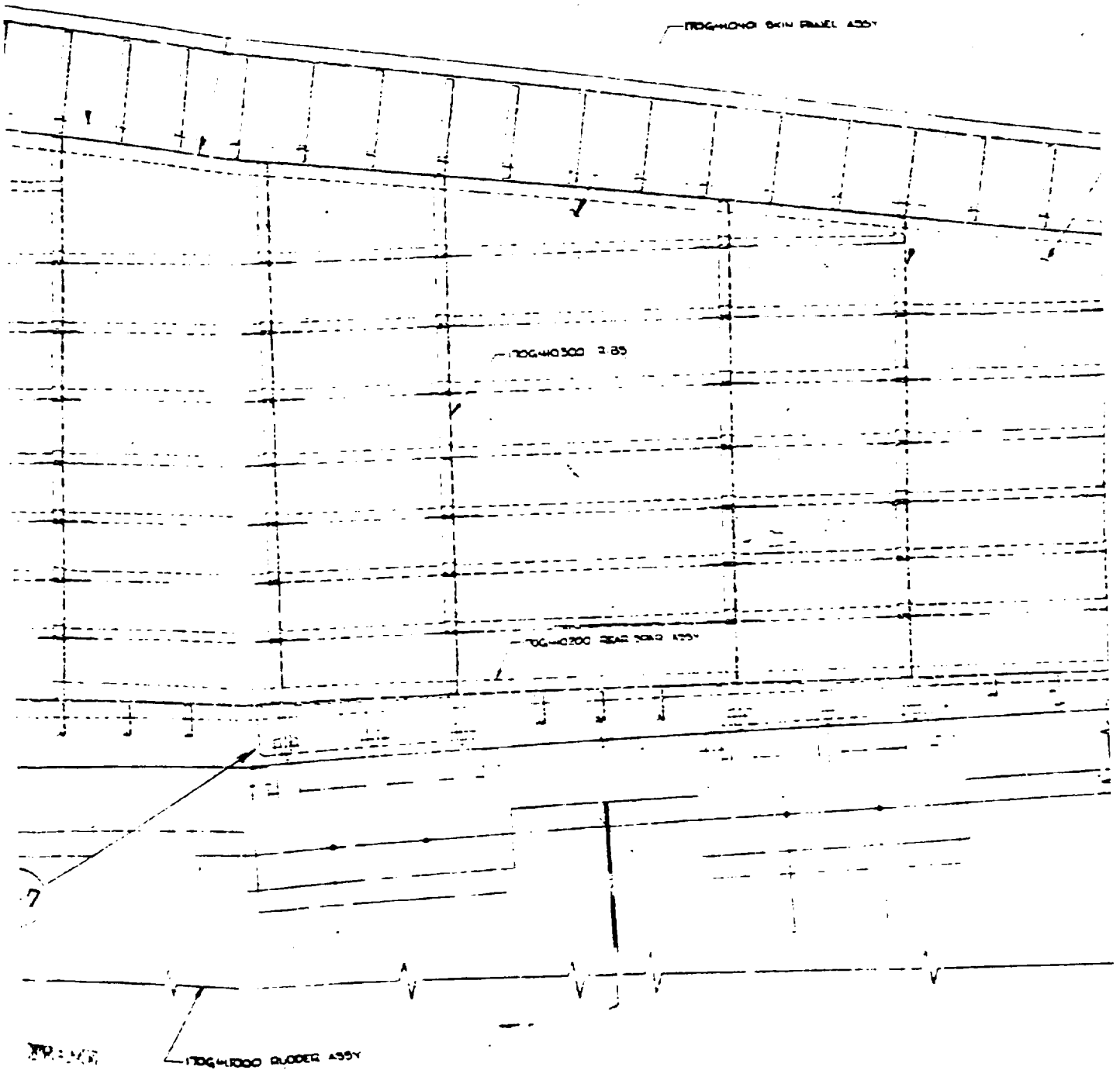

8-4 RIB WEB

8-1 SKIN

8-3 NOSE RIBS

8-2 STRINGERS

RUCOOR - FIN SEAL

2 1/2

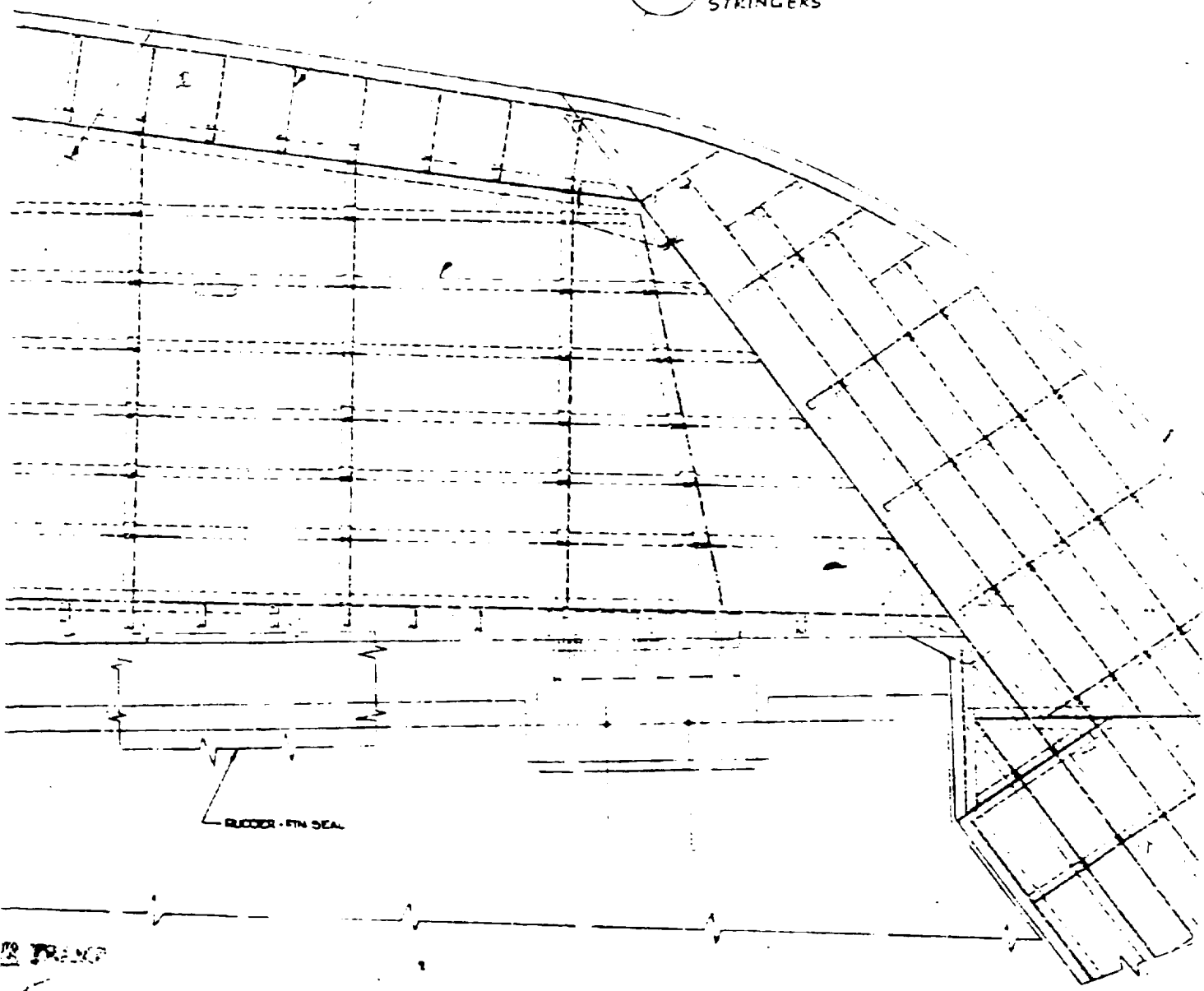

106-0600 TP ASDY

REPRODUCIBILITY OF THE
ORIGINAL PAGE IS POOR

106-0600

Figure 1.8.1 Vertical Stabilizer Fin Assembly

8-1

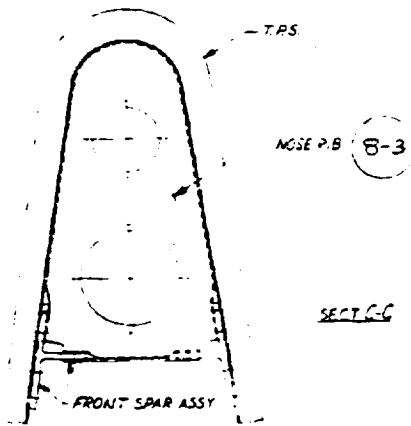
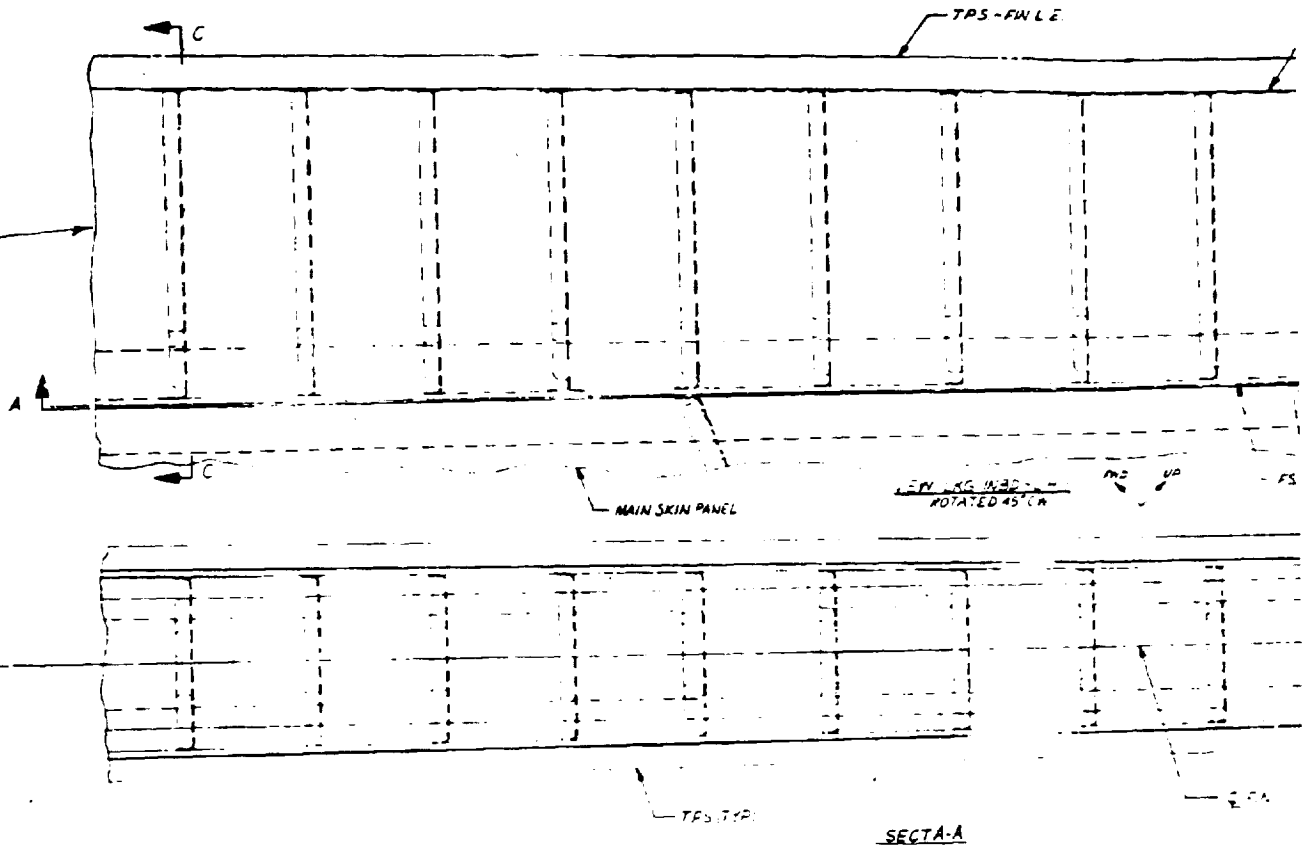

SECT
RIB ASSEMBLY

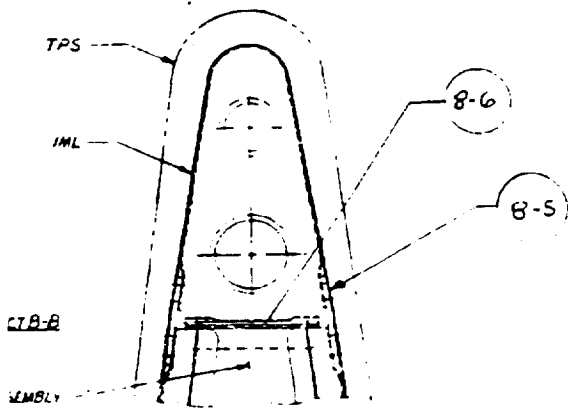
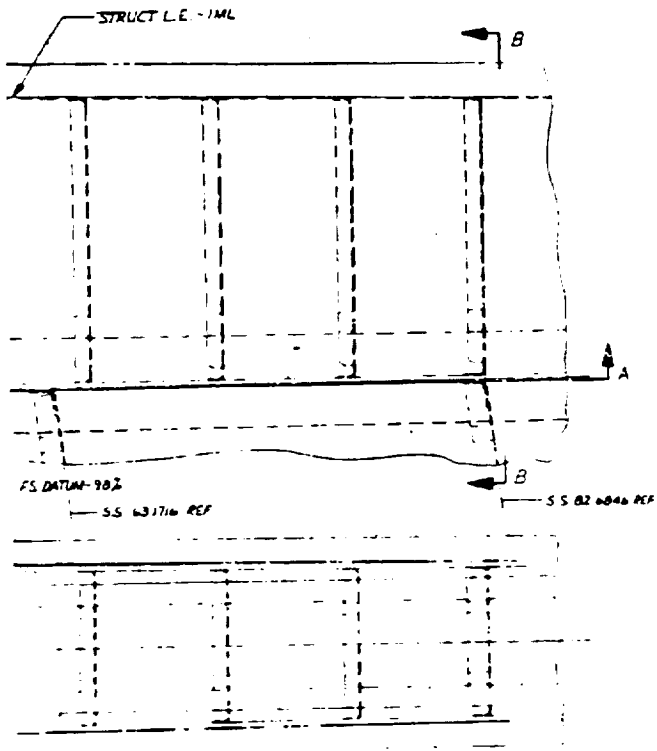
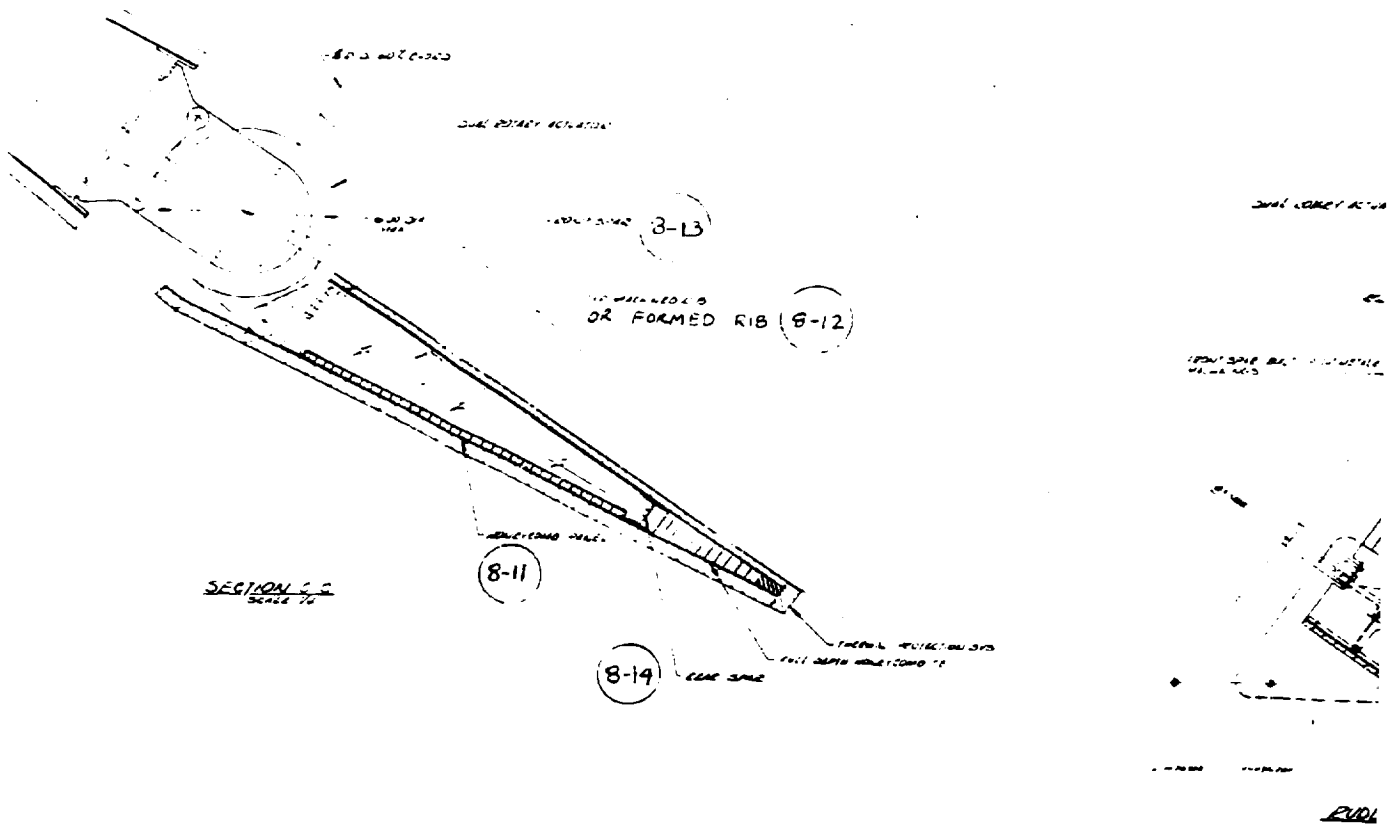
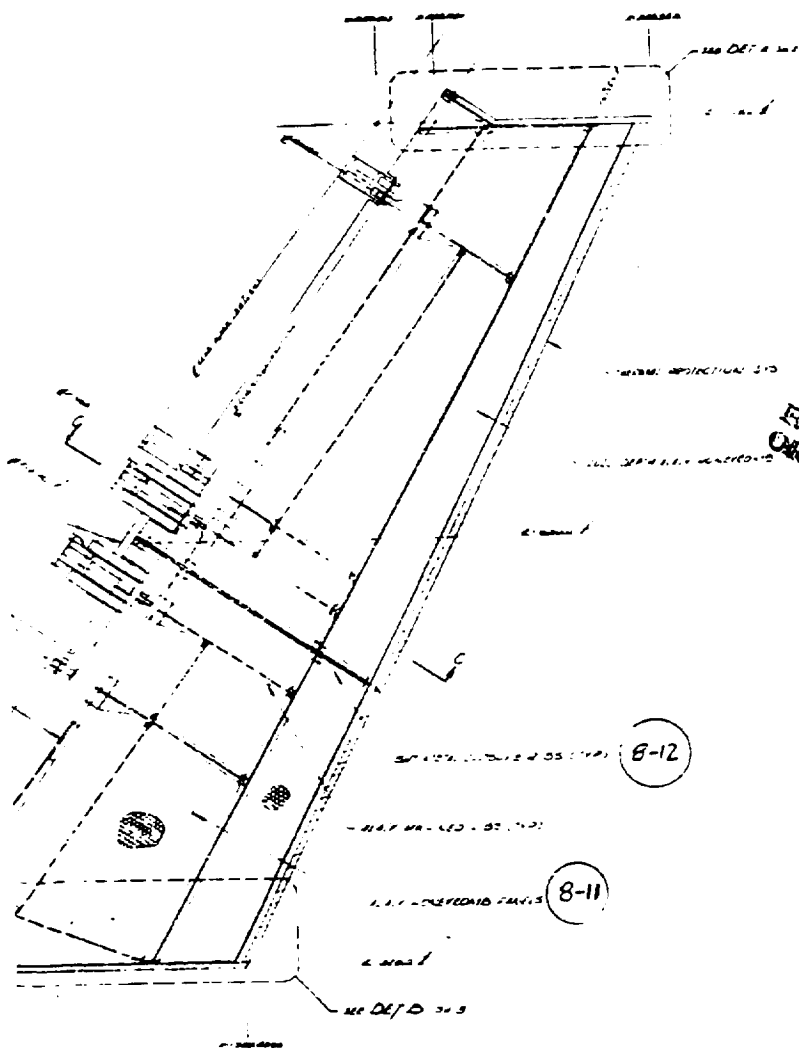

Figure 1.8.2. Vertical Stabilizer Leading Edge Assembly



BUILDING FRAME

1



REPRODUCIBILITY OF THE ORIGINAL PAGE IS POOR

D. CRANE - 3 DE 5. EV
12. 7. 10

Figure 1. 8. 3. Vertical Stabilizer Rudder Assembly

REPRODUCIBILITY OF THIS
ORIGINAL PAGE IS POOR

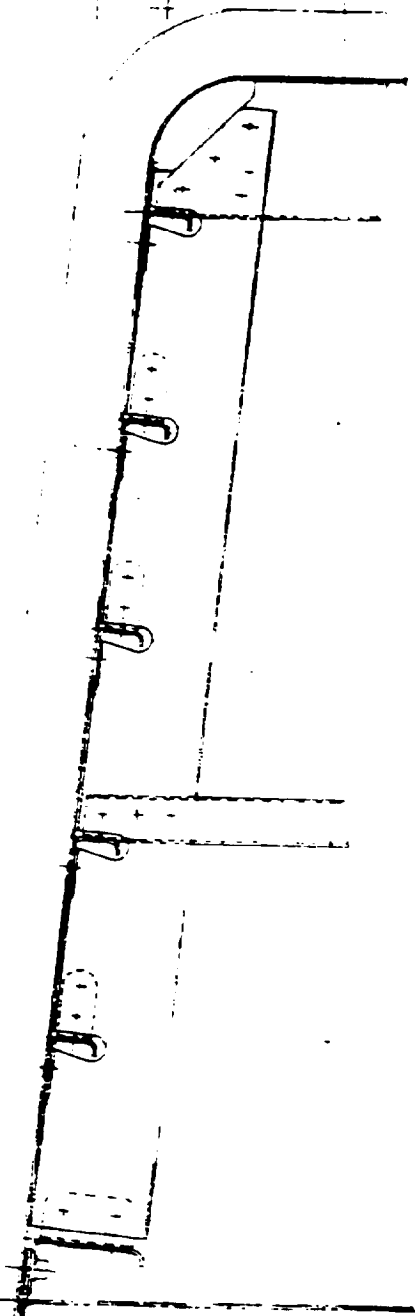

SECTION B-B
SCALE 1/2"
A-1028.78
(R10.7.53)



SECTION C-C
SCALE 1/2"
A-1028.78
(R10.7.53)

2-780

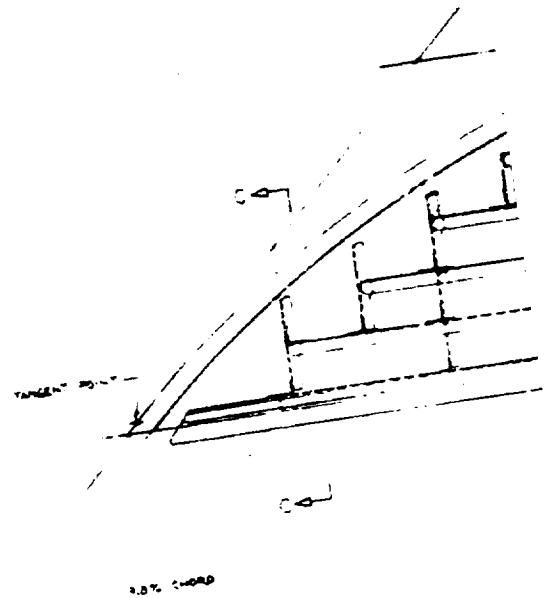
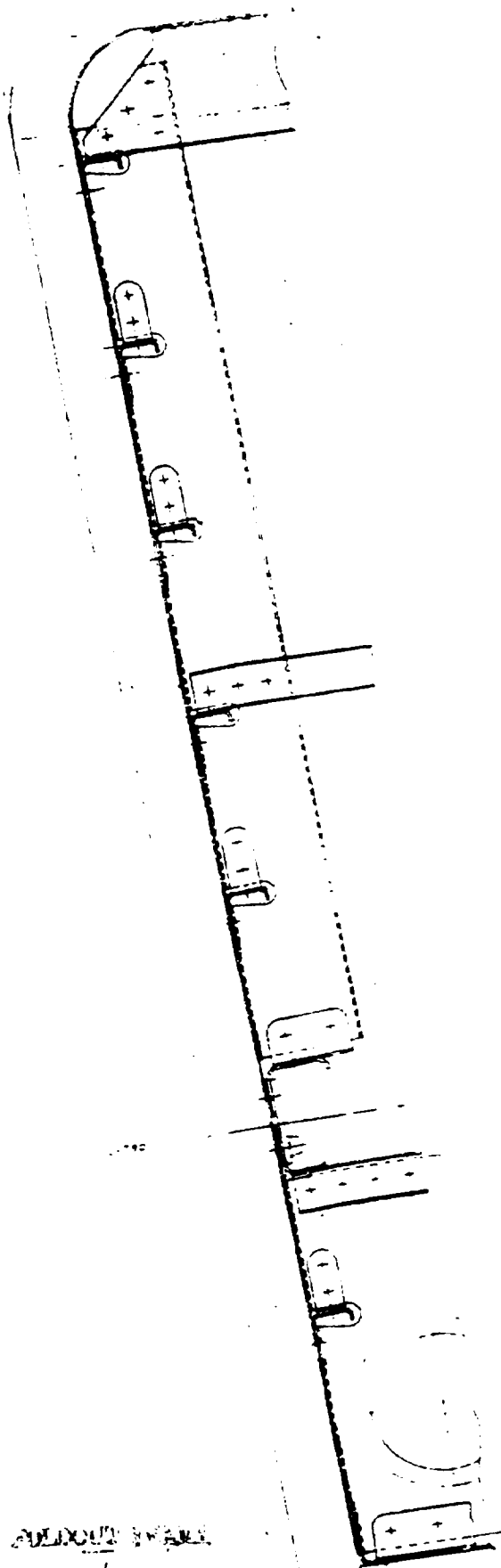

REPRODUCIBILITY OF THE
ORIGINAL PAGE IS POOR

OUTLINE WALL

SECTION A-A
SCALE
1" = 1'-0"

2.1780

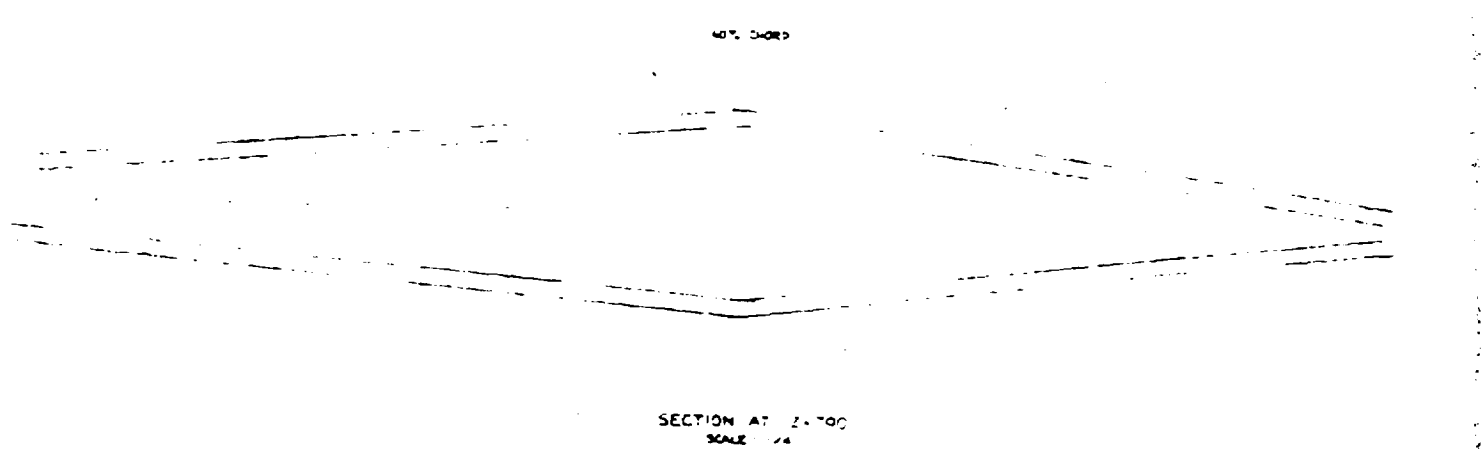
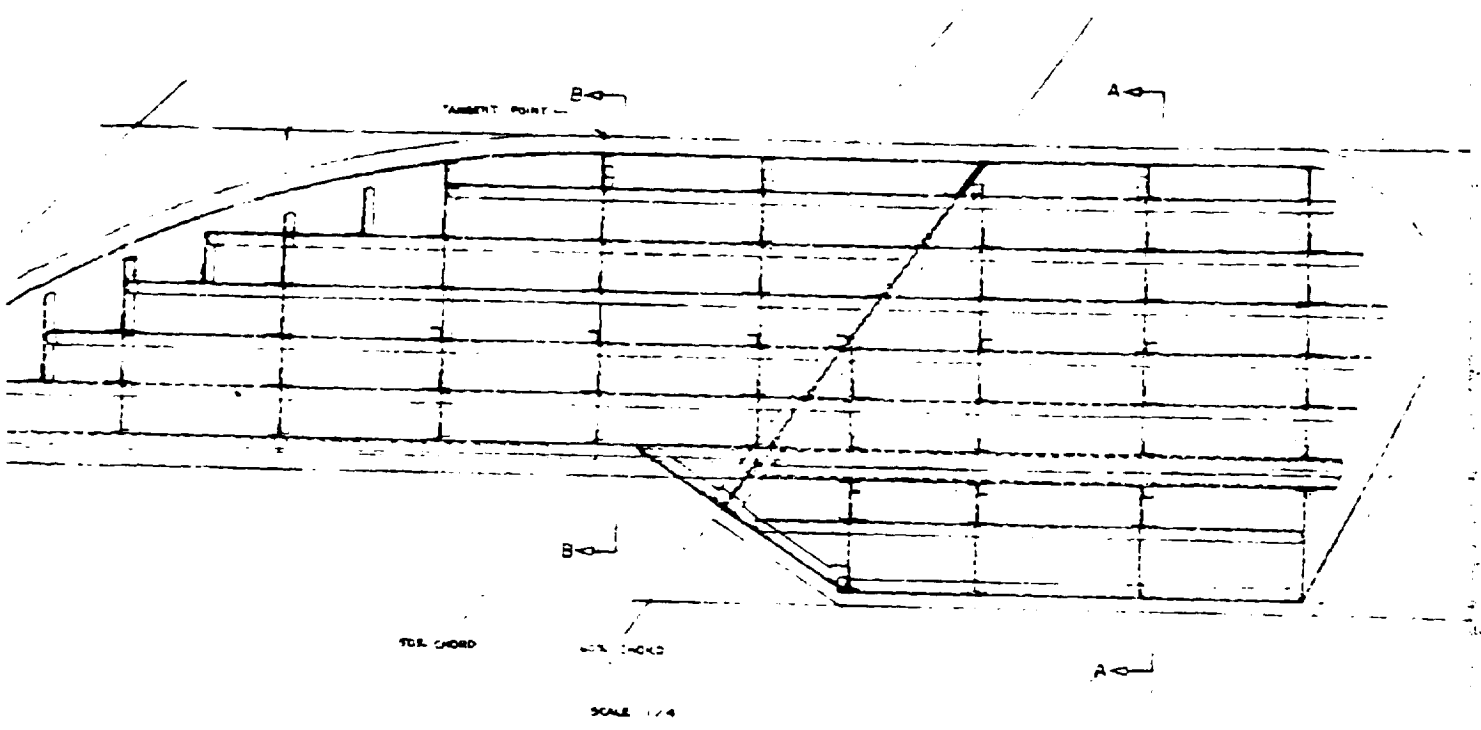

2 FRAM

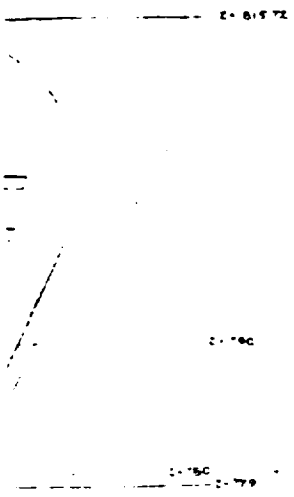
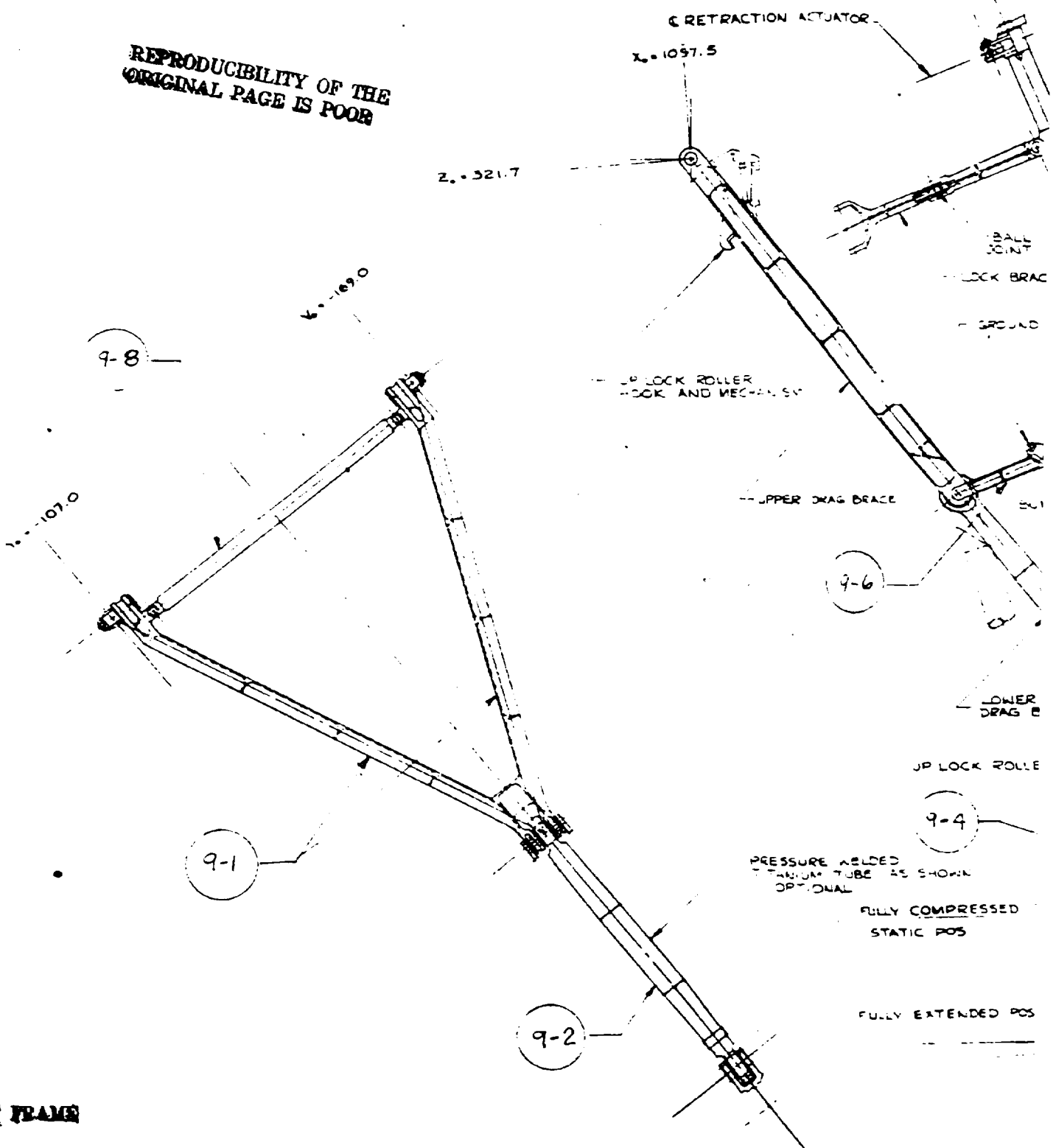
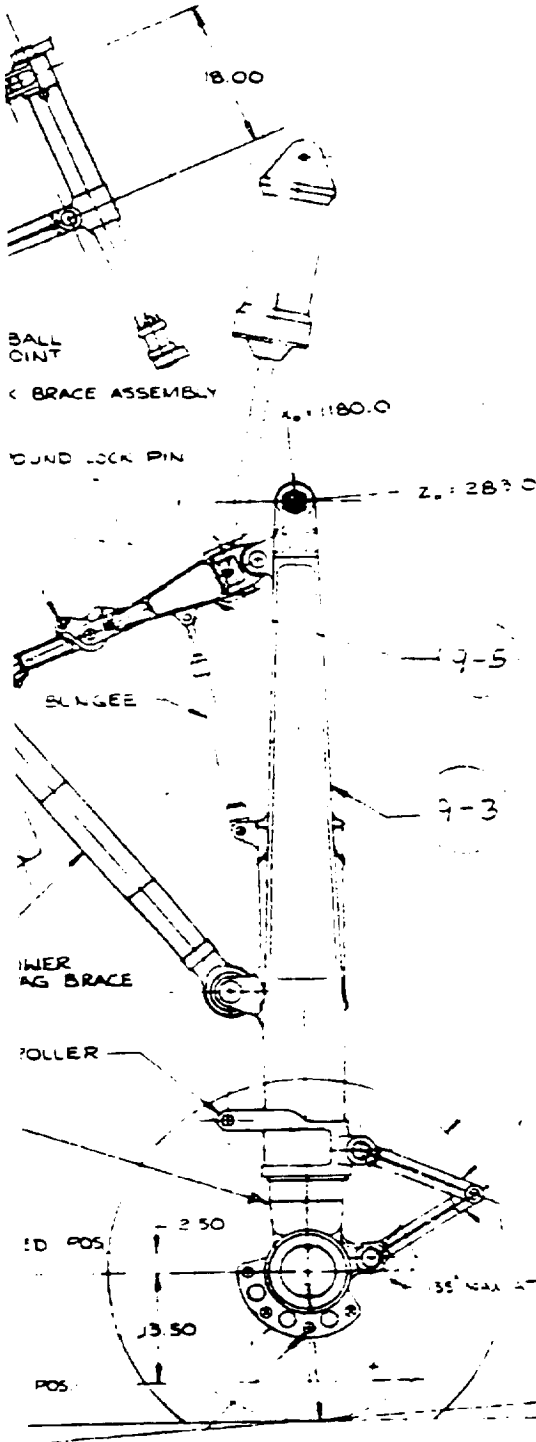

Figure 1.8.4. Vertical Stabilizer Tip Assembly

REPRODUCIBILITY OF THE ORIGINAL PAGE IS POOR



OUT FRAME



ANTI-ROTATION WASHER
2 PLACES

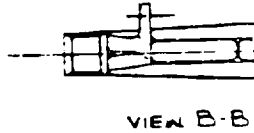

MEANS OF LOCATING THE
FLOATING PISTON FOR SER...

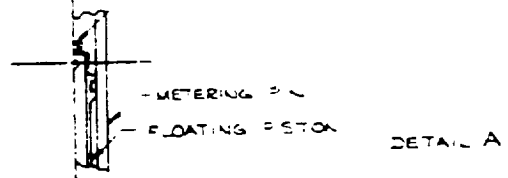

SPLINES

DETAIL A-A
SCALE 1/4

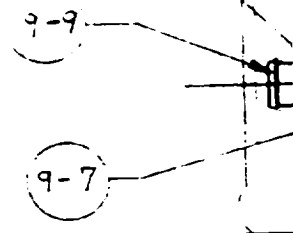

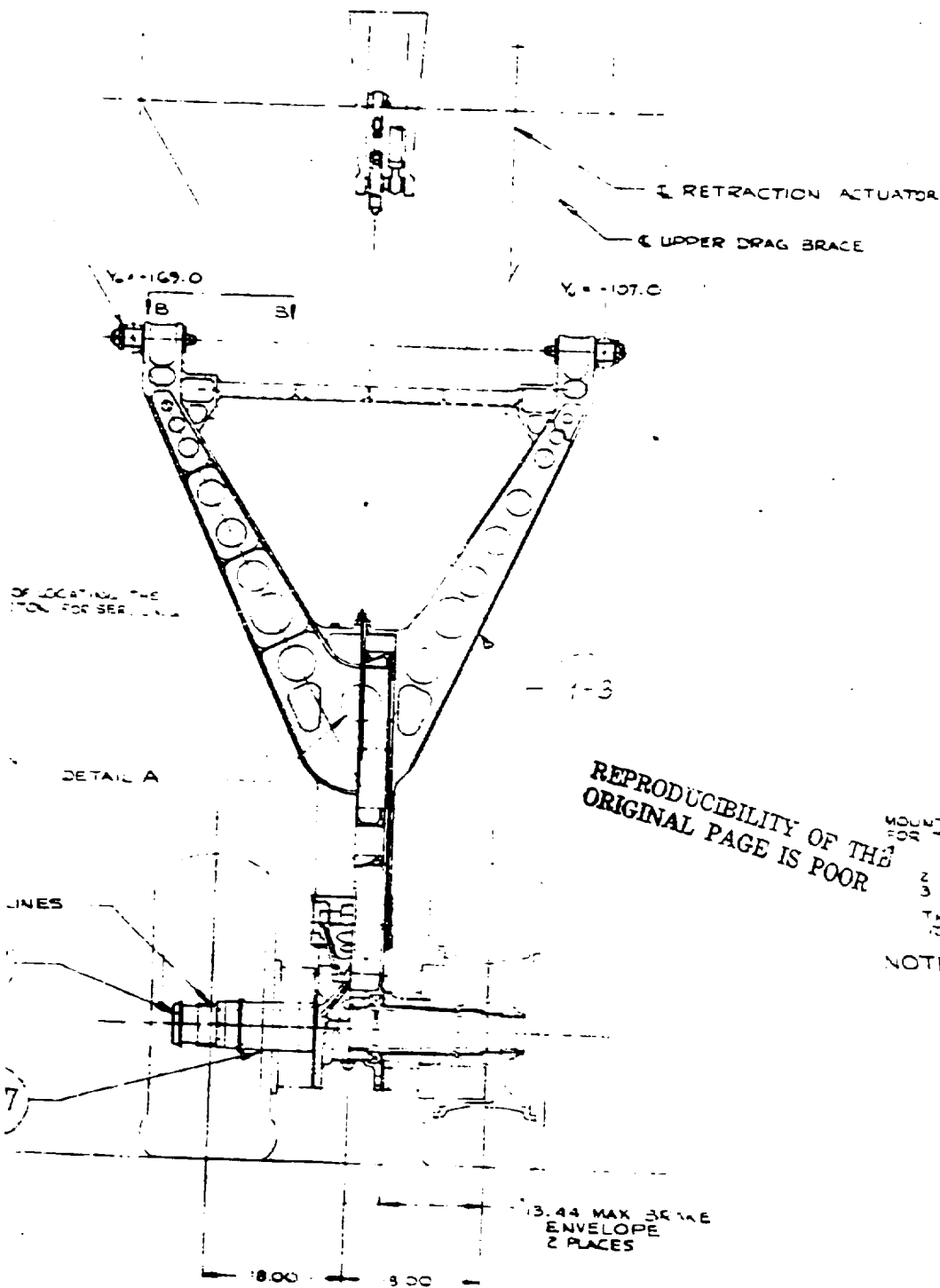

REPRODUCIBILITY OF THE ORIGINAL PAGE IS POOR

MOUNTING PROVISIONS SHALL BE PROVIDED FOR THE FOLLOWING:

- 1 DOWN WEIGHT ON WHEELS
- 2 DOWN LOCK SWITCHES
- 3 BRAKE LINES

THE EXACT LOCATION AND TYPE OF PROVISIONS TO BE PROVIDED BY THE CUSTOMER

NOTES:

Figure 1.9.1.

THE FOLLOWING SHALL BE PROVIDED:

DOWN WEIGHT ON WHEELS SWITCH
DOWN LOCK SWITCH
BRAKE LINES

THE EXACT LOCATION AND TYPE FOR THE ABOVE
SHALL BE PROVIDED BY THE BUYER

END

ROLLUP FRONT

4/

Figure 1.9.1. Main Landing Gear

.09 SHIMS EACH SIDE -
ONE PIN ONLY

Yo
2100

SYMM ABOUT

INTERNAL THDS FOR--
PIN REMOVAL

Yo
2100

ANTI ROTATION WASHER

INTERFACE PIN WITH .1750 ID -
AND .1531 WIDTH BEARING

9-11

REPRODUCIBILITY OF THIS
ORIGINAL PAGE IS POOR

VIEW HH

9-

~~XXXXXXXXXX~~

PRESS PORT

ELECTRICAL SUPPORT BOSS

RING PIN NUT

STEERING COLLAR ACTUATOR ATTACH

HYD & ELECT BRKT SUPPORT BOSS

OUTER CYLINDER

POWER STEERING WITH 5° MAX OVER TRAVEL

INNERFACE BOSSES WITH STEERING ACTUATOR

SECT F-F

20 2920 56

5° MAX TRAVEL FOR UNLOCKING

LOCK PIN

STEERING COLLAR

OUTER CYLINDER

MOUNTING SUPTS FOR SENSOR MECH

0° POWER STEERING

0° POWER STEERING

5° MAX

TORQUE COLLAR

SECT E-E 1/2 SCALE

PISTON POS SENSOR MECH REF

9-16

REPRODUCIBILITY OF THE ORIGINAL PAGE IS POOR

TRUN NUT RETENTION

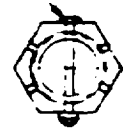

4.25

OIL PRESS PORT

30.00

54.20

F

STEERING CO

TORQUE COLL

SENSOR S

TAR

E

ANTI ROTATION WASHER

C

COMP POS

5.00

STATIC POS

35°

22.00

9-14

SECT B-E

EXTENDED POS

4.00

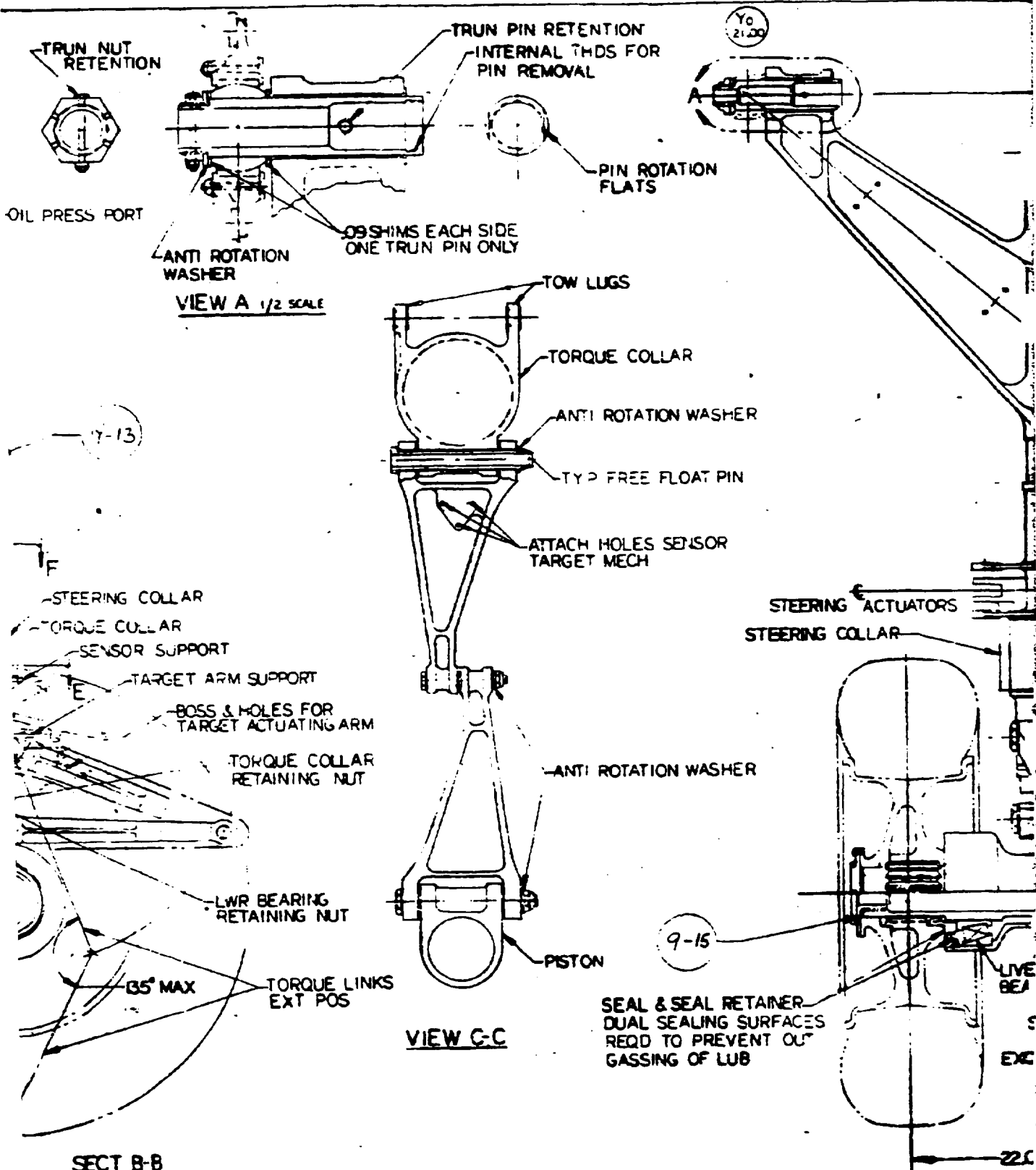

SECT B-B

FOLDOUT FRAME

4

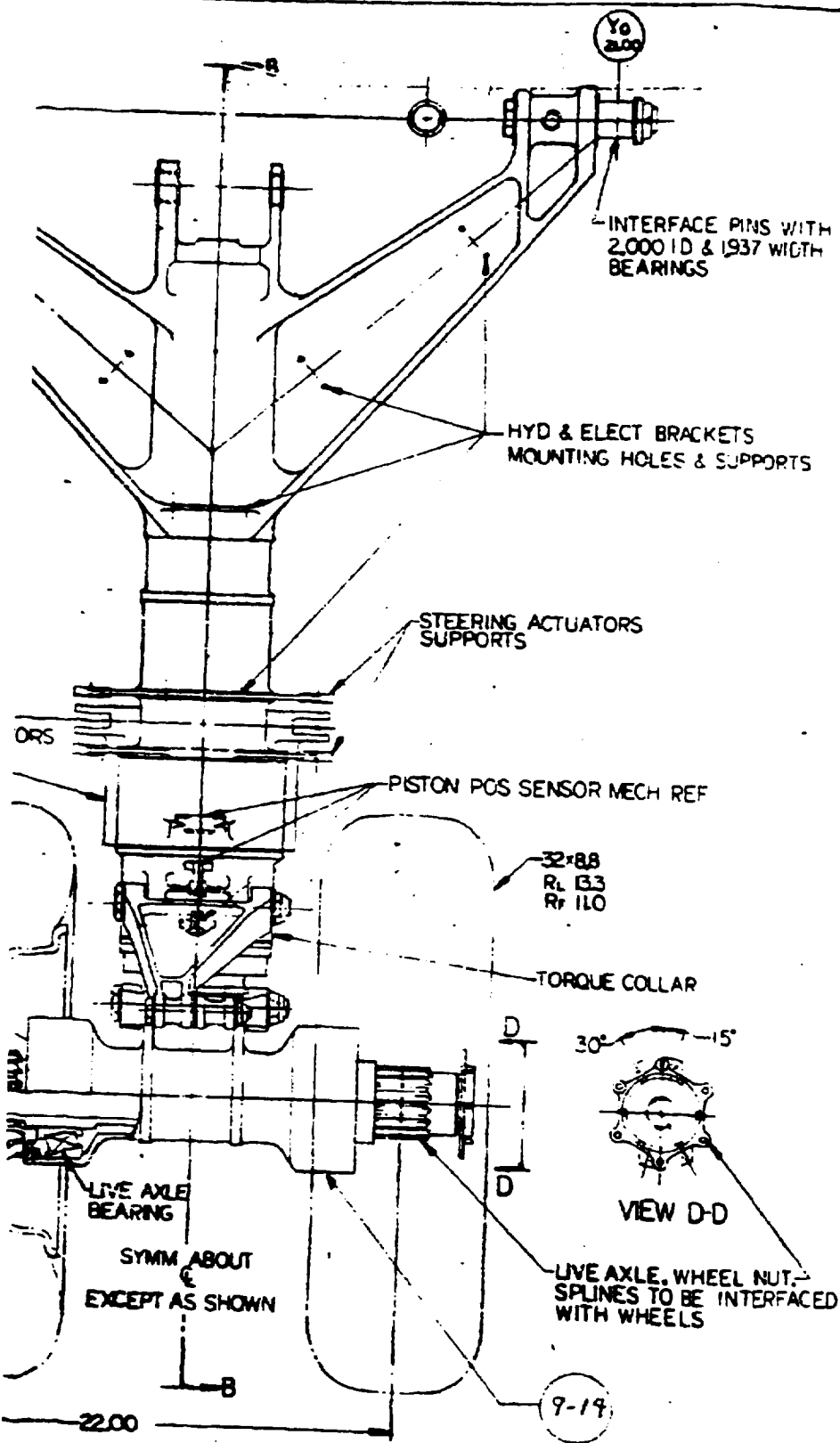

Figure 1.9.2. Nose Landing

INS WITH
37 WIDTH

TS
SUPPORTS

45°

3

HD

HEEL NUT
INTERFACED

5

FOLDOUT FRAME

6

Figure 1.9.2. Nose Landing Gear

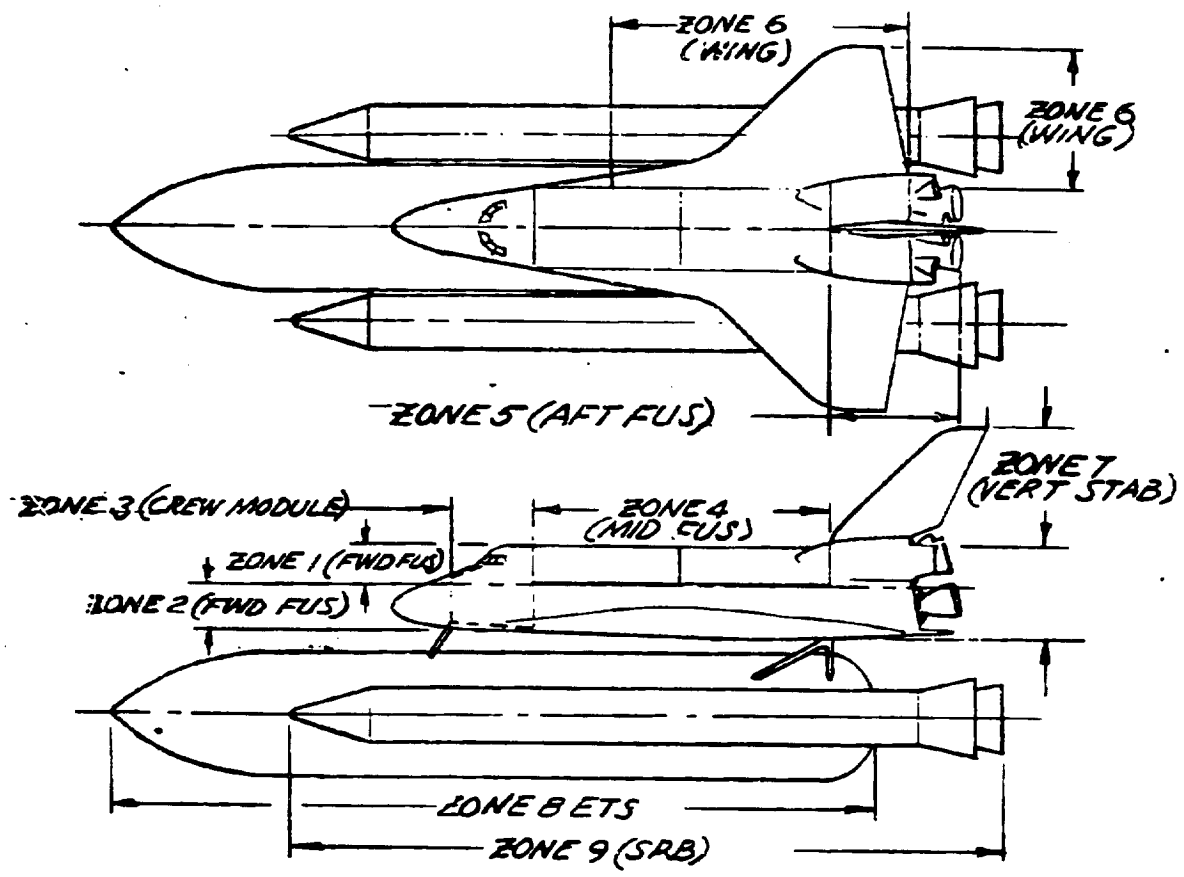
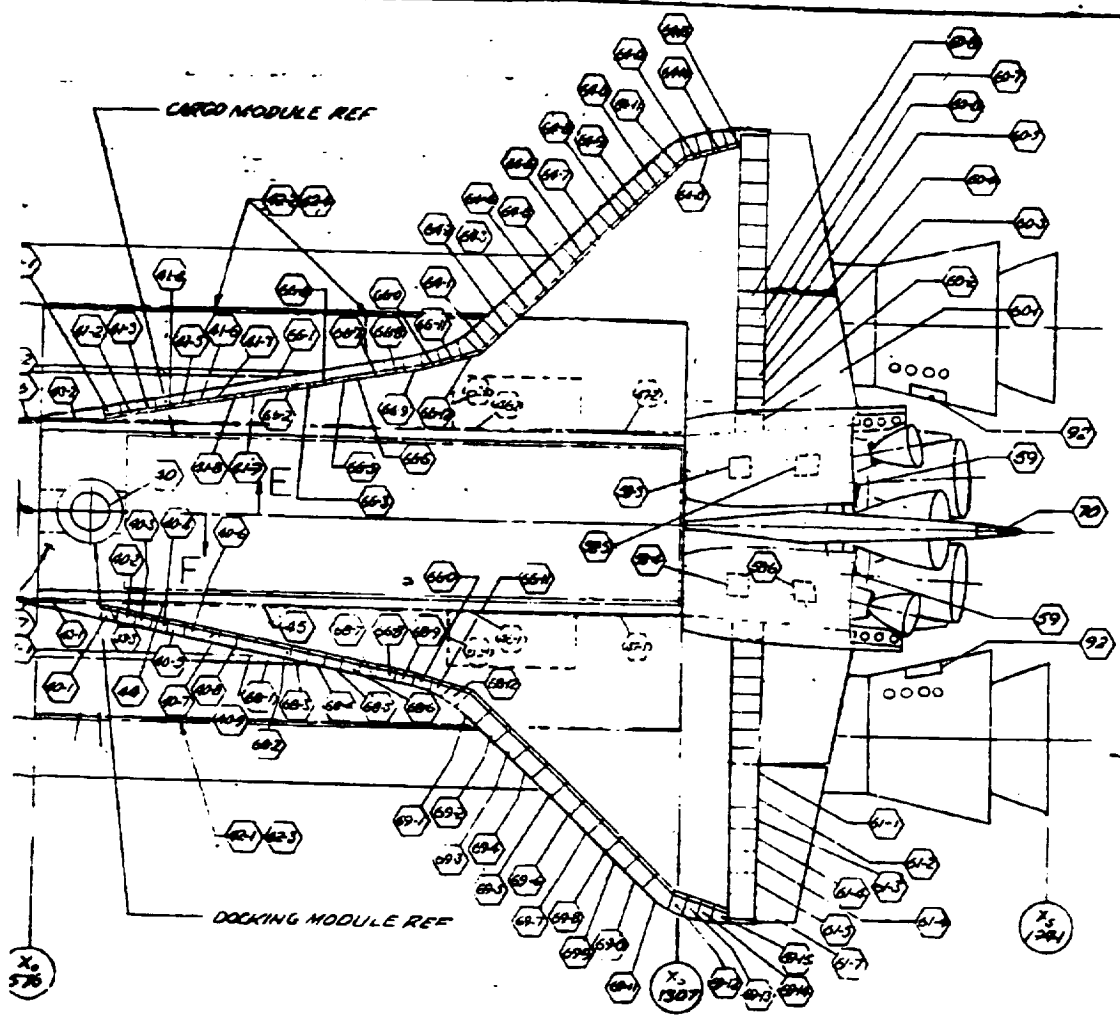

Figure 1.10.1. Shuttle Area Zone Breakdown



* LINER PROVISIONS FOR ACCESS TO CARGO BAY AREAS TBD

REPRODUCIBILITY OF THE ORIGINAL PAGE IS POOR

Figure 1.10.2. Shuttle Maintenance Access

REPRODUCIBILITY OF THE ORIGINAL PAGE IS FOUR

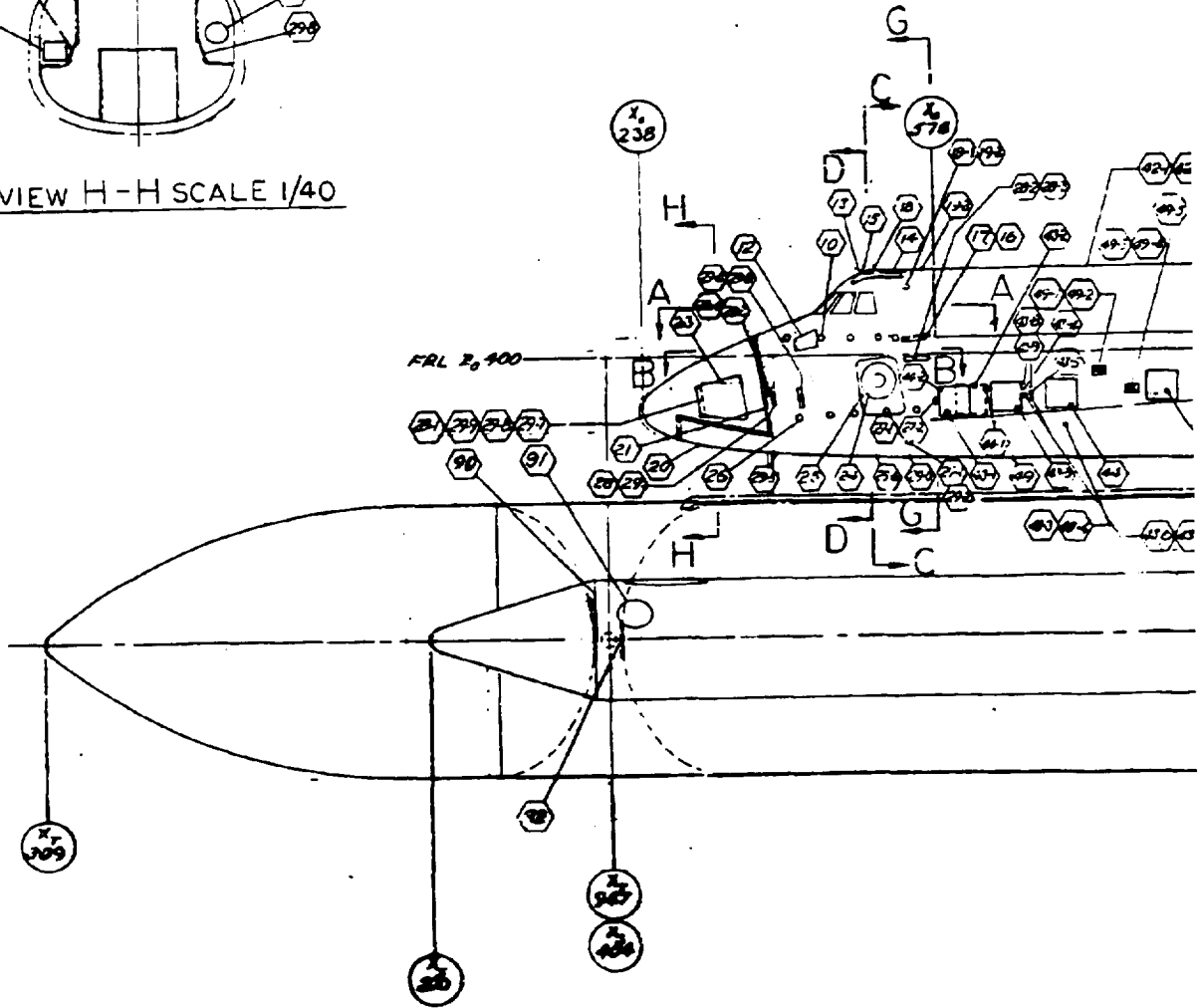
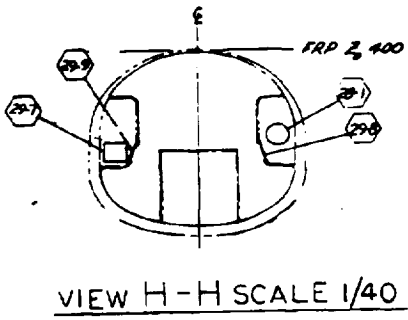

OUT FRAME

VL72-000071A SH 4

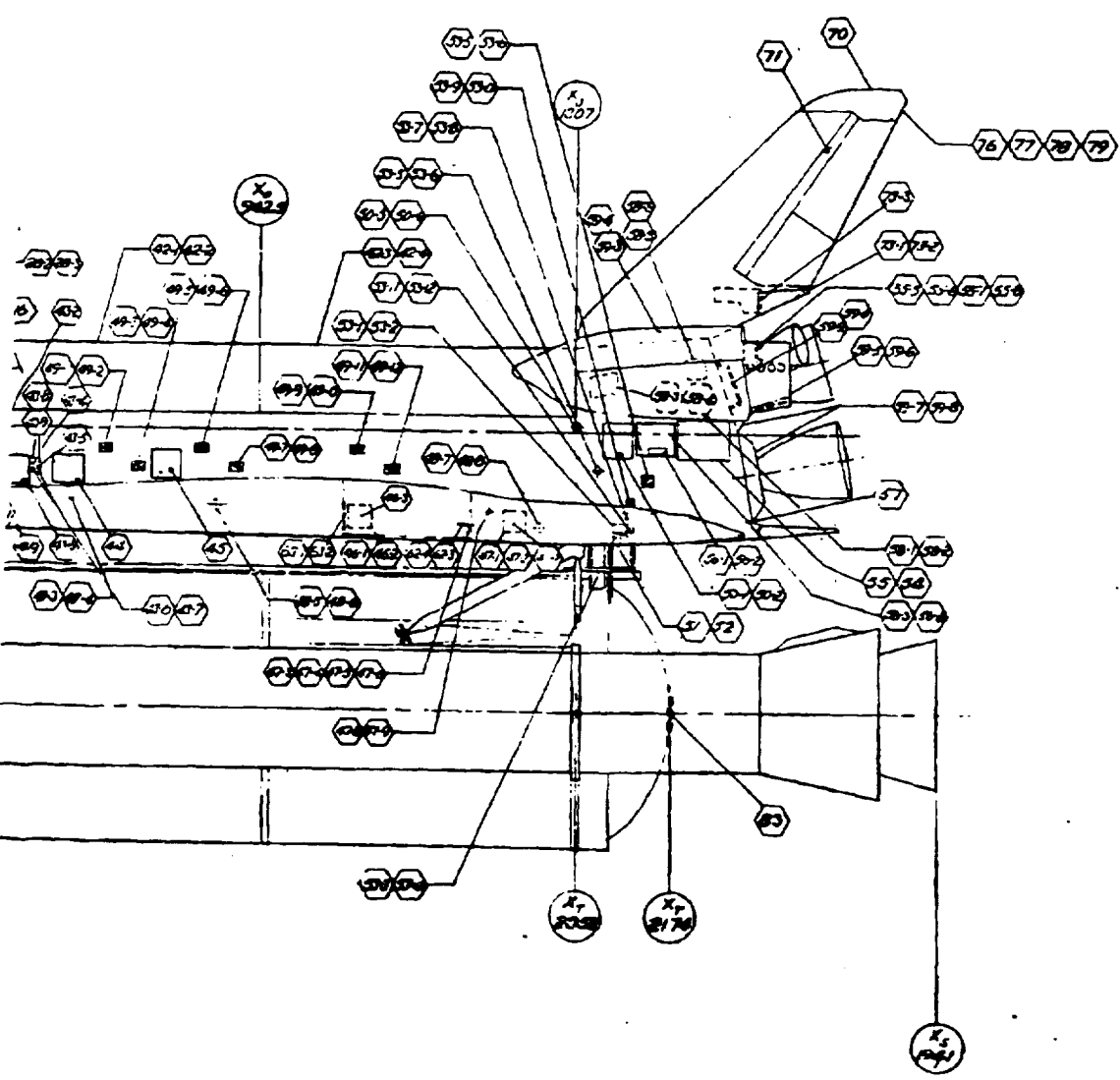

FOLDOUT FRAME

REPRODUCIBILITY OF THE ORIGINAL PAGE IS POOR

Figure 1.10.3. Shuttle Maintenance Access

REPRODUCIBILITY OF THE ORIGINAL PAGE IS POOR

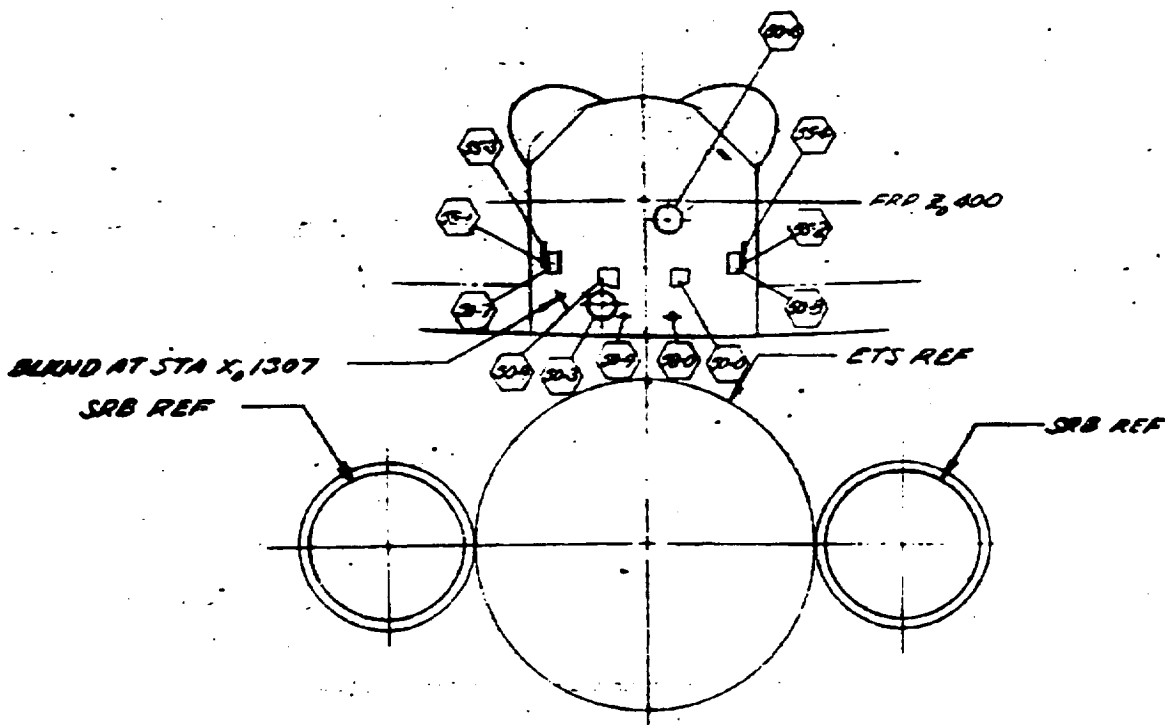

VIEW LOOKING FWD AT BLKHD STA X, 1307

FOLDOUT FRAME

KL72-06-71A SH 4 . 2

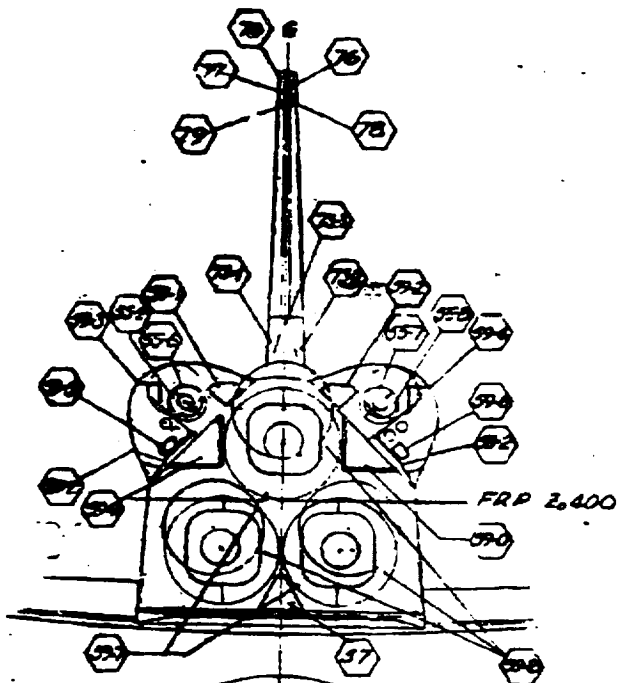

CARGO MODULE REF -

CARGO BAY TORQUE TUBE TYP (LN & RN)

ELECT/HYDR LINES ROUTING T-RU MID FUS TYP (LN & RN)

FRP 2₃

VIEW L

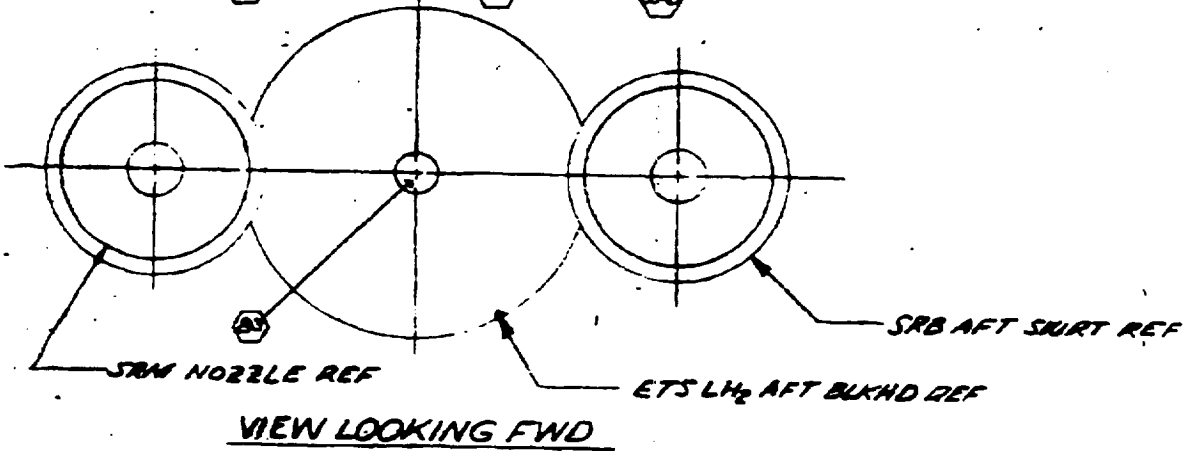

REPRODUCIBILITY OF THE ORIGINAL PAGE IS POOR

IT FRAME

2
2 104

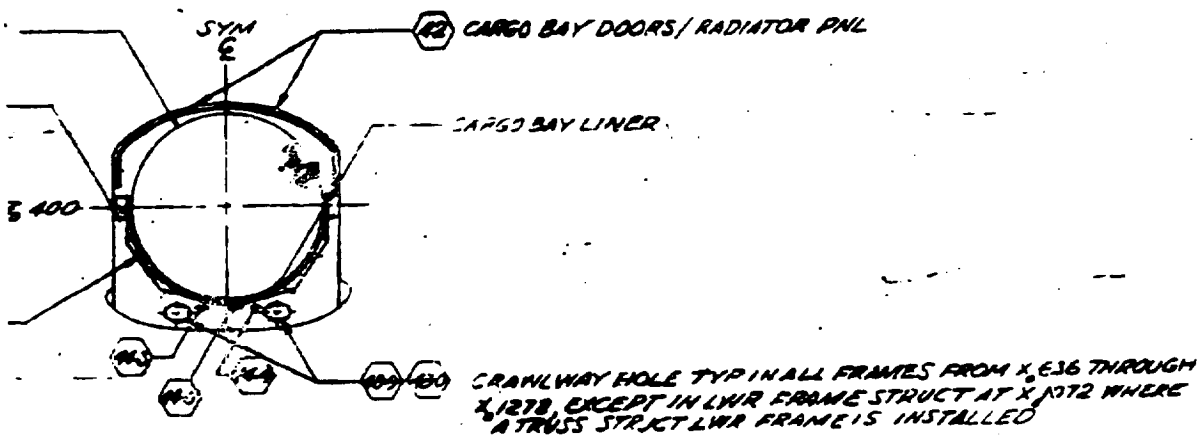

LOOKING AFT AT ORBITER STA X 636

REPRODUCIBILITY OF THE ORIGINAL PAGE IS POOR

AME

Figure 1.10.4. Shuttle Maintenance Access -

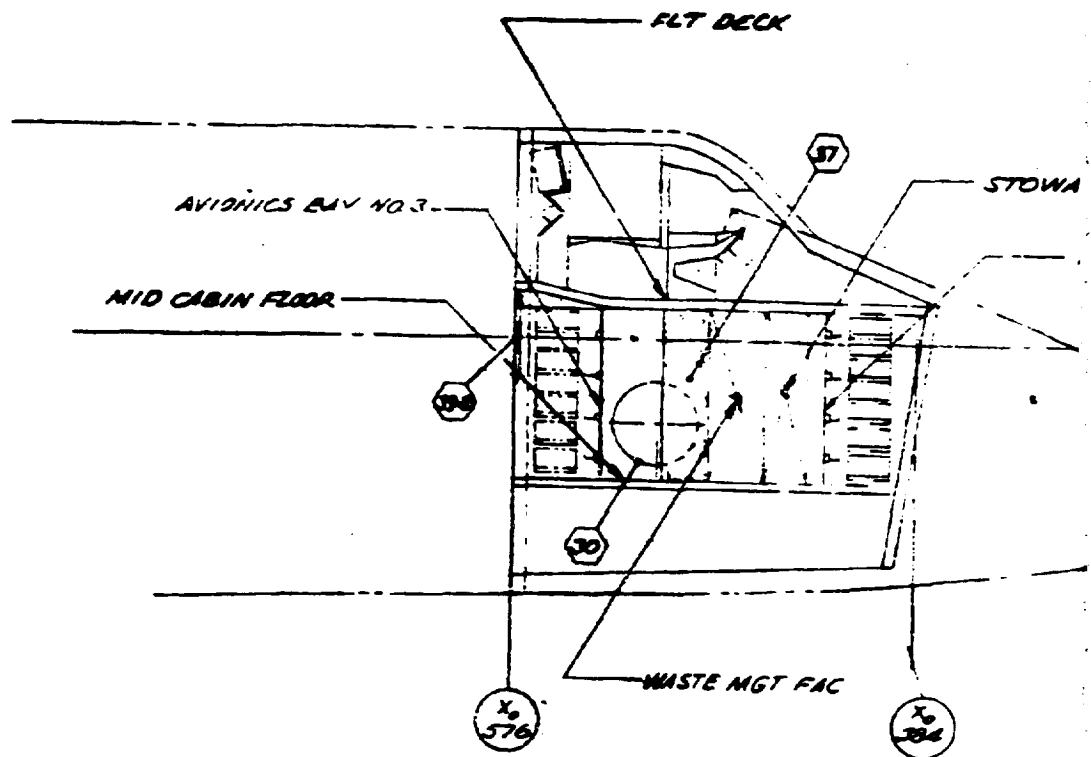

VIEW F-F ROTATED CW 180
(SCALE 1/40)

REPRODUCIBILITY OF THE
ORIGINAL PAGE IS POOR

FOLDOUT FRAME

CREW MODULE FIT DECK

CREW MOD
CABIN FLL

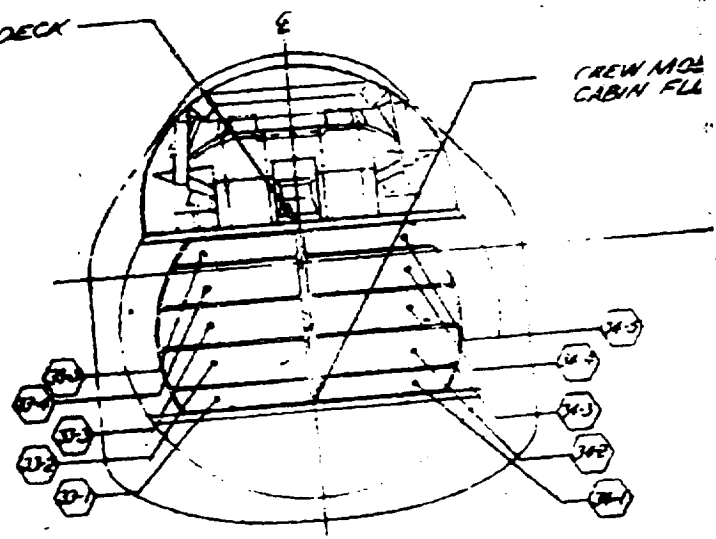

VIEW D-D SCALE 1/40

GE COMPARTMENT

AVIONICS BAY NO. 1

FRL 2,400



180 DEG

REPRODUCIBILITY OF THE ORIGINAL PAGE IS POOR

AVIONICS BAY NO. 2

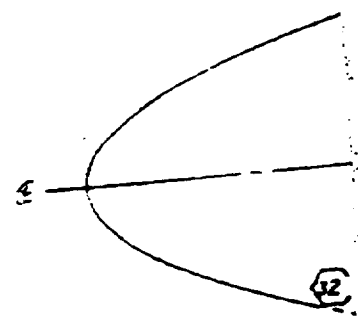

AVIONICS BAY NO. 1

JT FRAME

2

3 1/3

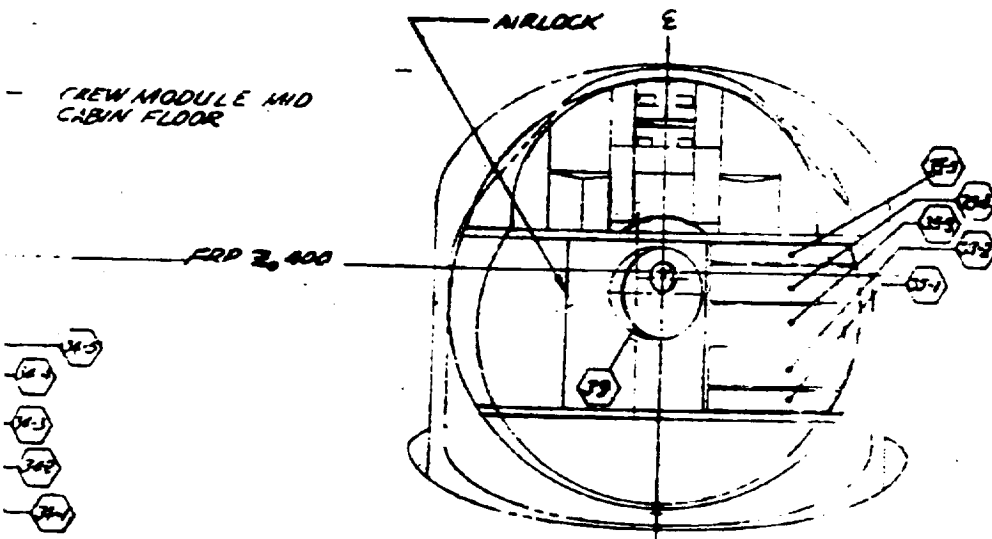

CREW MODULE AND CABIN FLOOR

FRP 2, 400

VIEW C-C SCALE 1/40

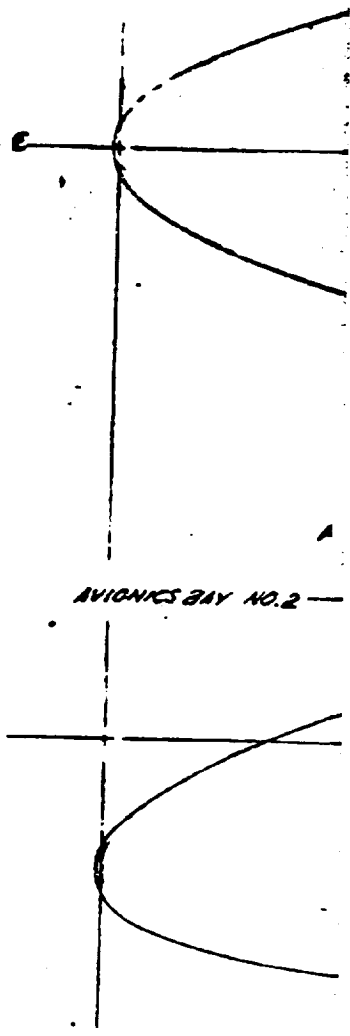

AVIONICS BAY NO. 2

STORAGE COMPARTMENT

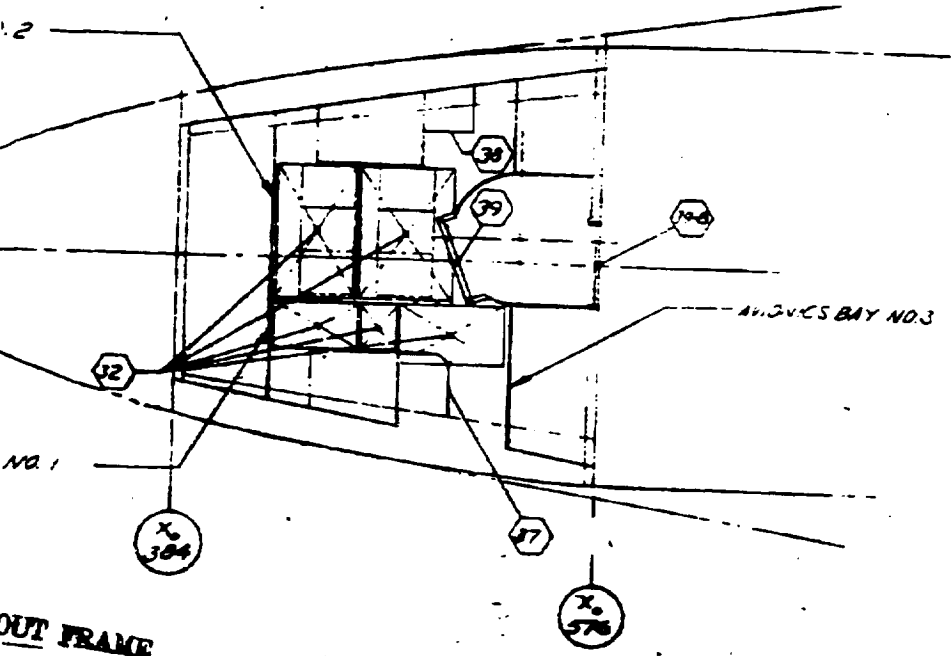

AVIONICS BAY NO. 3

NO. 1

OUT FRAME

VIEW B-B SCALE 1/40

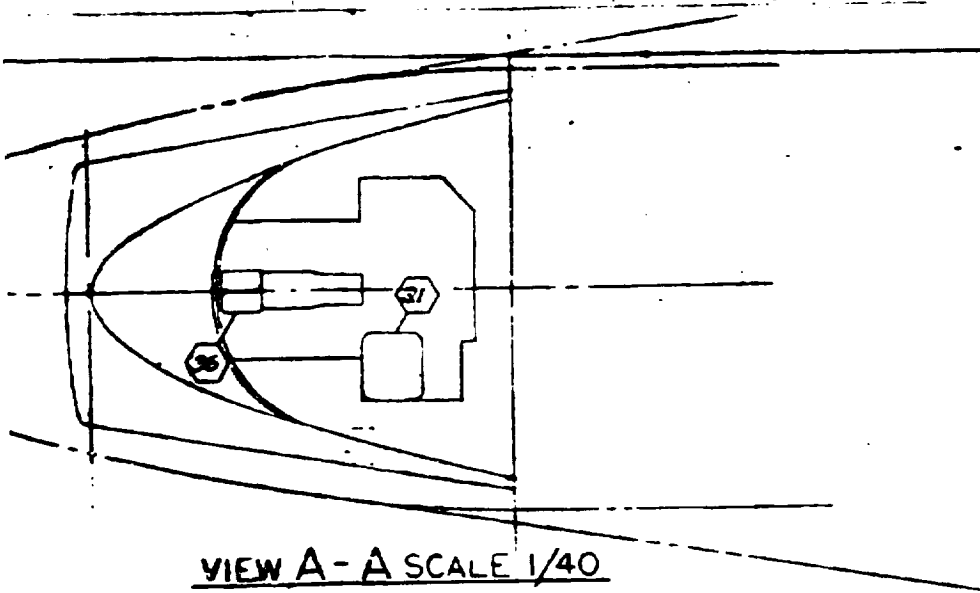

VIEW A - A SCALE 1/40

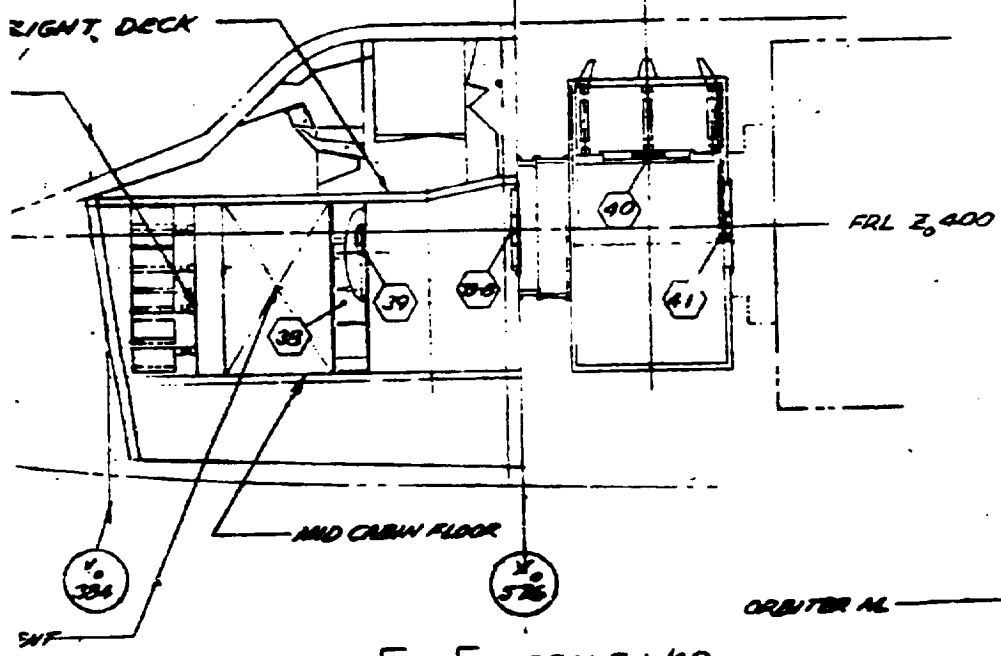
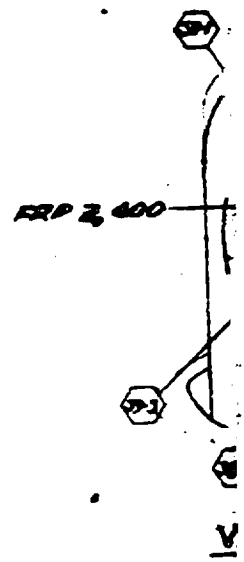

VIEW E - E SCALE 1/40

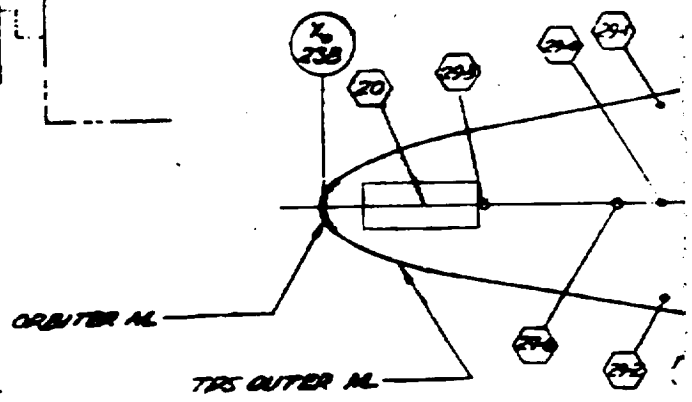

RANK

ORBITE

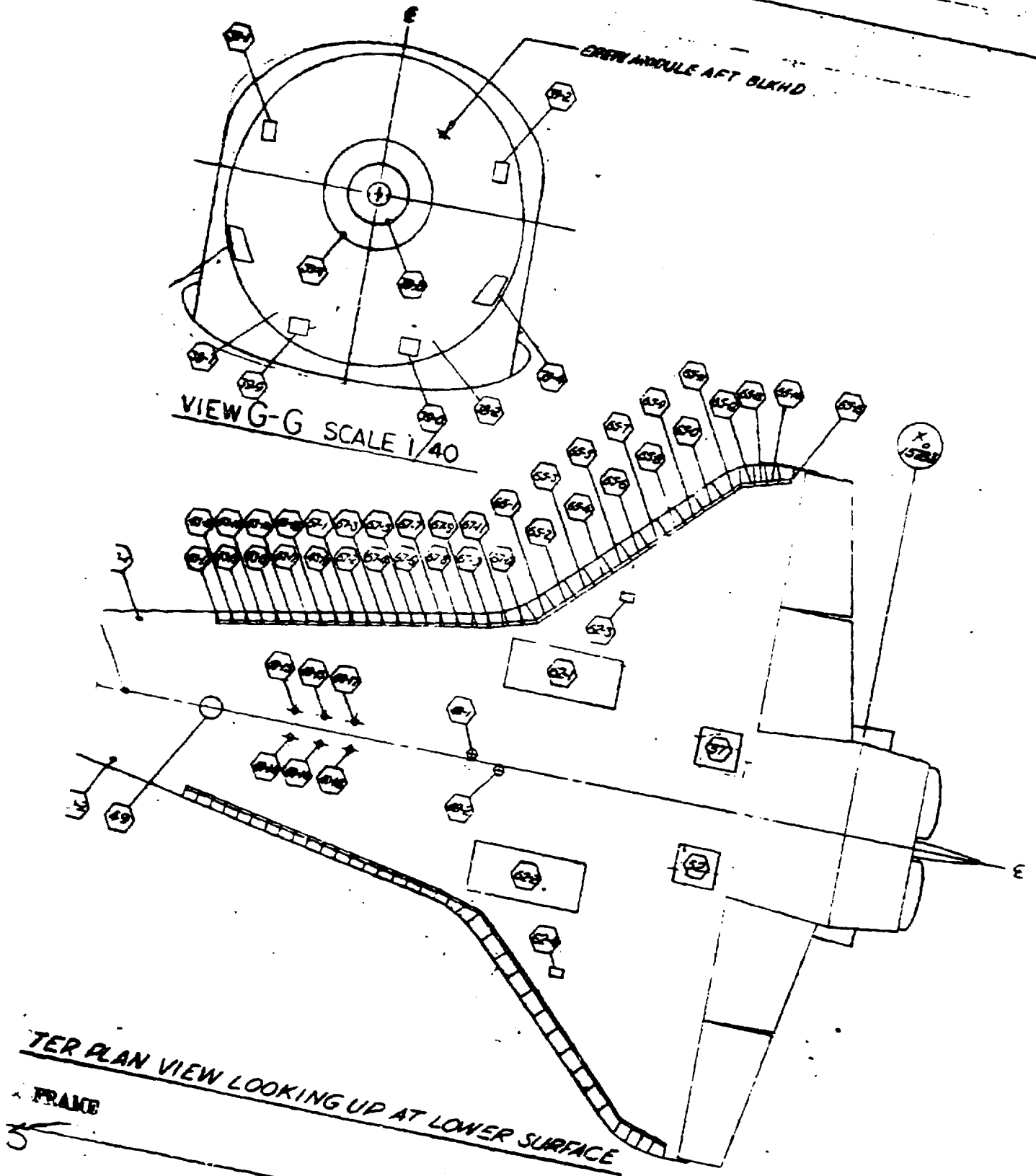
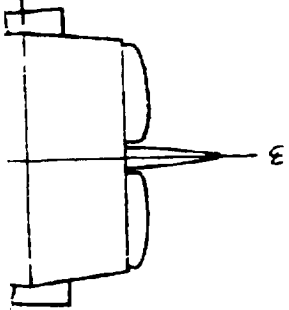

Figure 1.10.5. Shuttle Maintenance

X
5289



FIXED BRAKE



10.5. Shuttle Maintenance Access

