

NASA TECHNICAL NOTE



NASA TN D-7740

NASA TN D-7740

(NASA-TN-D-7740) SIMULATION STUDIES OF STOL AIRPLANE OPERATIONS IN METROPOLITAN DOWNTOWN AND AIRPORT AIR TRAFFIC CONTROL ENVIRONMENTS (NASA) 41 p HC \$3.75	N75-10038
CSCL 01E H1/03	Unclas 53793



**SIMULATION STUDIES OF STOL AIRPLANE
OPERATIONS IN METROPOLITAN DOWNTOWN AND
AIRPORT AIR TRAFFIC CONTROL ENVIRONMENTS**

by Richard H. Sawyer and Milton D. McLaughlin

*Langley Research Center
Hampton, Va. 23665*



1. Report No. NASA TN-D-7740		2. Government Accession No.		3. Recipient's Catalog No.	
4. Title and Subtitle SIMULATION STUDIES OF STOL AIRPLANE OPERATIONS IN METROPOLITAN DOWNTOWN AND AIRPORT AIR TRAFFIC CONTROL ENVIRONMENTS				5. Report Date November 1974	
				6. Performing Organization Code	
7. Author(s) Richard H. Sawyer and Milton D. McLaughlin				8. Performing Organization Report No. L-9663	
9. Performing Organization Name and Address NASA Langley Research Center Hampton, Va. 23665				10. Work Unit No. 768-81-04-01	
				11. Contract or Grant No.	
12. Sponsoring Agency Name and Address National Aeronautics and Space Administration Washington, D.C. 20546				13. Type of Report and Period Covered Technical Note	
				14. Sponsoring Agency Code	
15. Supplementary Notes					
16. Abstract <p>The operating problems and equipment requirements for STOL airplanes in terminal area operations in simulated air traffic control (ATC) environments were studied. These studies consisted of Instrument Flight Rules (IFR) arrivals and departures in the New York area to and from a downtown STOLport, STOL runways at John F. Kennedy International Airport, or STOL runways at a hypothetical international airport. The studies were accomplished in real time by using a STOL airplane flight simulator and the Federal Aviation Administration ATC simulation facilities. The flight simulator was operated by government research pilots and airline crews and the ATC simulator was operated by experienced air traffic controllers. An experimental powered-lift STOL airplane and two in-service airplanes having high aerodynamic lift (i.e., STOL) capability (De Havilland Twin Otter and Buffalo) were used in the simulations.</p>					
17. Key Words (Suggested by Author(s)) STOL Air traffic control Terminal area				18. Distribution Statement Unclassified - Unlimited STAR Category 02	
19. Security Classif. (of this report) Unclassified		20. Security Classif. (of this page) Unclassified		21. No. of Pages 39	22. Price* \$3.25

SIMULATION STUDIES OF STOL AIRPLANE OPERATIONS
IN METROPOLITAN DOWNTOWN AND AIRPORT AIR TRAFFIC
CONTROL ENVIRONMENTS

By Richard H. Sawyer and Milton D. McLaughlin
Langley Research Center

SUMMARY

The operating problems and equipment requirements for STOL airplanes in terminal area operations in simulated air traffic control (ATC) environments were studied. These studies consisted of Instrument Flight Rules (IFR) arrivals and departures in the New York area to and from a downtown STOLport, STOL runways at John F. Kennedy International Airport, or STOL runways at a hypothetical international airport. The studies were accomplished in real time by using a STOL airplane flight simulator and the Federal Aviation Administration ATC simulation facilities. The flight simulator was operated by government research pilots and airline crews and the ATC simulator was operated by experienced air traffic controllers. An experimental powered-lift STOL airplane and two in-service airplanes having high aerodynamic lift (i.e., STOL) capability (De Havilland Twin Otter and Buffalo) were used in the simulations.

In the severely limited airspace of downtown operations with the powered-lift STOL airplane, departures along curved tracks having way points about every 3 n. mi. were difficult to fly. Way points spaced this closely created a high navigation workload. Pilot opinion was that such tracks should be composed of straight segments with way points at least 5 n. mi. apart. For arrivals along horizontally curved descending tracks, the navigation workload was high with only simple area navigation (RNAV) and straight-in instrument landing system (ILS) guidance. Precise horizontally curved descending flight-path guidance for obstacle clearance and proper airspace usage was found to be a requirement. Because of limited airspace, development of a technique for conversion to powered-lift flight after glide-slope acquisition was indicated to avoid the difficulty of conversion on the curved path. The pilots also recommended that autospeed control and good handling qualities be provided in order to reduce the workload to an acceptable level for this powered-lift airplane in the approach maneuver.

In airport operations, maneuvers required for traffic separation and for sequencing often resulted in high workloads for the crew. Steep descent maneuvers, requested on entering the final approach control area and for descent to glide-slope intercept altitude,

together with precise navigation requirements indicated a need for three-dimensional RNAV procedures. In the final control area, numerous heading, speed, and altitude changes were experienced in sequencing and spacing operations, the average number of maneuvers required (based on arrivals from the four cardinal points) being four heading, two airspeed, and one or two altitude changes. Lengthy sequencing maneuvers also added to the crew workload.

INTRODUCTION

Because of their short takeoff and landing capability, STOL airplanes offer the potential of operations at small airports within or adjacent to city central business districts. Shorter downtown-to-downtown travel times are thus a possibility. The slow speed and steep descent capability of STOL airplanes provide the maneuverability required to take advantage of the small amounts of unused airspace in metropolitan terminal areas. STOL airplanes thus appear to have the potential for providing commuter and short haul feeder operations at existing airports with only small effects on existing operations. An increase in traffic handling capacity in congested hub areas appears possible with these airplanes.

To explore the potential gains and the problems of integrating STOL airplanes into such environments, the National Aeronautics and Space Administration (NASA) and the Federal Aviation Administration (FAA) have conducted joint simulation experiments. The investigations were accomplished by linking a STOL airplane flight simulator at the NASA Langley Research Center to the air traffic control (ATC) simulator at the FAA National Aviation Facilities Experimental Center. Simulated environments representing operations at a potential New York downtown STOLport and for various possible STOL runway configurations at John F. Kennedy International Airport were investigated. Government research pilots and airline pilots were used to operate the STOL flight simulator. An experimental powered-lift STOL airplane and two in-service airplanes having high aerodynamic lift (i.e., STOL) capability were simulated.

The experiments were designed to meet both FAA and NASA objectives. For the FAA, the basic objective of the studies was to determine the effects of the STOL airplane on the ATC system. Specific objectives included determination of the effects of STOL airplane operations on the traffic capacity, on airspace requirements, on ATC equipment, and on ATC handling procedures required to accommodate these operations. The results of the studies relative to the FAA objectives are reported in reference 1. For the NASA, the basic objective of the studies was to determine the requirements for the STOL airplane for operations in the ATC system. Specific objectives included analysis of the requirements relative to design characteristics, avionics equipment, and flight procedures. The results of the studies relative to the NASA objectives are reported herein.

SYMBOLS AND ABBREVIATIONS

Values are given in both SI and U.S. Customary Units. The measurements and calculations were made in U.S. Customary Units.

V_i	indicated airspeed, knots
$\Sigma\psi$	summation of heading changes required by nominal path in a departure or arrival operation, deg
ARR	arrival
ATC	air traffic control
CTOL	conventional takeoff and landing
DME	distance measuring equipment
EWR	Newark International Airport
FAA	Federal Aviation Administration
IFR	Instrument Flight Rules
JFK	John F. Kennedy International Airport
LGA	LaGuardia Airport
NAFEC	National Aviation Facilities Experimental Center
RNAV	area navigation
STOL	short takeoff and landing
TEB	Teterboro Airport
VHF	very high frequency

VOR VHF omnirange
VORTAC VOR station with DME provision
W.P. way point

EQUIPMENT

A block diagram showing the simulation facilities and their interconnections is given in figure 1. At the NASA Langley Research Center, a transport flight-deck simulator connected to the general-purpose computer facility was used to represent one of the STOL airplanes used in the investigation. This equipment was connected to the FAA ATC simulator at the National Aviation Facilities Experimental Center (NAFEC) in Atlantic City, New Jersey, by means of data and voice-communication lines. The ATC simulator was used to create a real-time simulated environment of scheduled airline operations under air traffic control.

STOL Airplane Simulator

The flight compartment of the fixed-base airplane flight simulator used is similar to that of current jet-transport airplanes (fig. 2). The flight instrumentation, radio communication and navigation controls, and ATC beacon transponder controls were all similar to those used in current jet-transport airplanes. The flight instrumentation included a flight director system with attitude director indicator, horizontal situation indicator, and DME readout. Controls for setting up a single area navigation way point based on distance and bearing from a VORTAC station were provided. A pictorial navigation display with a 14- by 19-cm (5.5- by 7.5-in.) screen was located in the lower center portion of the flight instrument panel. Maps used on this display depicted only basic route, navigation, and ATC information.

The characteristics of the STOL airplanes simulated were programed on a digital computer. The aerodynamic characteristics were programed as a function of angle of attack, flap deflection, and thrust. Engine thrust and fuel flow characteristics were programed as a function of altitude and throttle position. Equations for six degrees of freedom were used in the representation of the airplane motions.

The digital computer was also programed to supply error-free slant range distance and bearing information from several simulated VORTAC stations and localizer and glide-slope deviation information from a simulated instrument landing system (ILS).

ATC Simulator

The ATC facilities that were simulated consisted of approach, departure, and tower control positions for both CTOL and STOL airplanes, as required. The area controlled was approximately 60 by 60 n. mi. The ATC facilities were staffed by 10 to 14 experienced air traffic controllers, depending on the experiment. The controllers were provided with modern television-type radar displays having automatic target tracking, symbology generation, and visual handoff features, and target data tags specifying airplane identification, ground speed, and altitude.

The air traffic environment was generated by means of a digital computer. Depending on the experiment, 80 to 106 controllable radar targets were generated. Each simulated target was programmed to have representative performance characteristics of a particular class of airplane. The target was also programmed to follow a scheduled flight plan. The flight plan, however, was modified in real time, as required by the controllers, by means of keyboard entries to the computer made by 24 pseudo "pilots" reacting to the instructions received over an interphone network.

Data Transmission and Communications

Position information in the three rectilinear coordinates and ground speed information of the simulated STOL airplane at Langley Research Center were transmitted over a data telephone line to the ATC simulator. A radar beacon transponder signal was also transmitted over this same line. This information was used to create a radar target and associated data tag on the controller displays at NAFEC.

The pilots of the STOL simulator at Langley Research Center and the controllers at NAFEC communicated over voice telephone lines. The voice lines were connected to the VHF radio communication system in the STOL simulator and to the interphone system at NAFEC.

TEST PROGRAM

General Description

In the first set of experiments, the existing New York airports were supplemented by a downtown STOLport. In the second set of experiments, STOL runway arrangements at an isolated, large, busy CTOL airport and one STOL runway arrangement at JFK were investigated. The simulated ATC facility included pertinent New York Common IFR Room control positions plus necessary control positions for STOLport and STOL runway operations. The simulated air traffic environment consisted of representations of peak-day CTOL scheduled operations in the New York area and a flow of STOL airplanes,

larger in number than could be accommodated, in order to keep pressure on the system. The STOL airplane traffic mix at NAFEC consisted of representations of the De Havilland Twin Otter, Buffalo, and DHC-7 airplanes, the experimental augmentor-wing STOL airplane (modified Buffalo), and the Breguet/Dassault 941 airplane. The STOL airplanes simulated at Langley Research Center were the experimental augmentor-wing STOL airplane (downtown STOLport experiments) and the Twin Otter and Buffalo airplanes (airport experiments).

The general test conditions were as follows:

- (1) All operations were conducted under Instrument Flight Rules.
- (2) The ATC facility had radar surveillance of and radio communications with all traffic.
- (3) Traffic was basically handled by ATC on a first come, first served basis.
- (4) Adequate ground-based navigation aid signals were available along all flight paths required of STOL airplanes.
- (5) Separation of climbing and descending traffic was effected by use of prescribed altitude clearance levels along the routes.
- (6) Ninety percent of the STOL airplanes had area navigation capability.
- (7) Glide-slope angles of either 7° or $7\frac{1}{2}^{\circ}$ were used for STOL airplane final approaches. (See fig. 3 for the special geometry of the glide slope and localizer course widths used to provide satisfactory sensitivity of the path deviation information on the flight instrumentation.)

The STOL airplane simulator was operated by a crew of two pilots. Because of the experimental nature of the augmentor-wing STOL airplane simulated, research pilots from NASA and FAA were used in the downtown experiments. Pilots from two commuter airlines (Command Airways and Pilgrim Aviation and Airlines) and two trunk airlines (American and Eastern) operated the simulator in the airport experiments. The horizontal and vertical flightpaths were controlled manually through conventional flight controls. The turbine speed of both engines was controlled by a single throttle lever. The adjacent lever on the throttle quadrant was used to control the angle of the adjustable nozzles (augmentor-wing STOL airplane) or the propeller speed (Twin Otter and Buffalo airplanes). Horizontal and vertical guidance on the airway and area navigation routes and on the straight segments of the final approach course was provided by flight director steering commands.

Departure operations were initiated just prior to scheduled departure time by a radio call from the First Officer to ATC departure control for clearance instructions

and ended in cruising flight at the perimeter of the controlled area. Arrival operations were initiated by a call for an inbound clearance. Upon receipt of clearance, the arrival was begun in cruising flight on the assigned route over a VOR station near the edge of the controlled area and ended at touchdown on the runway.

Experiments at Downtown STOLport

The simulated downtown STOLport was located on the west bank of the Hudson River at the Morris Canal which is about opposite the Trade Center Building on lower Manhattan Island. (See fig. 4.) The STOLport had two 609.6 m (2000 ft) runways having centerline magnetic headings of approximately NE/SW and E/W. Independent STOL airplane routes (fig. 5), including low altitude airway, RNAV, and curved path segments, were developed to serve the STOLport without modification to the current New York ATC operating procedures for the three most usual CTOL traffic flows as dictated by different wind directions. Relatively low altitudes (1230 and 1530 m (4000 and 5000 ft)) were used on these routes. For all three traffic flows, the STOL airplane landings were made toward the southwest on the NE/SW runway. Takeoffs were made either towards the southwest on the NE/SW runway or towards the west on the E/W runway. For the arrivals, the controllers used speed control for all spacing adjustments and for sequencing the traffic from opposite directions. Mileage marks at 5-n. mi. intervals along the arrival routes were used to predict the longitudinal separation of the airplanes on the common path. A standard longitudinal separation of 3 n. mi. on final approach was used.

STOL airplane characteristics.- The augmentor-wing STOL airplane simulated (modified Buffalo) is an experimental powered-lift STOL airplane to be used in flight research (ref. 2). The airplane, as modified, has two split-flow turbofan engines replacing the turbopropeller engines. Augmented lift is obtained by exhausting the cold air from the front fans through a slotted flap arrangement. The hot gas flow exits through nozzles whose orientation can be adjusted in flight to provide control of the thrust vector through a vertical angle of 98° .

The airplane simulated had a weight of 178 000 N (40 000 lb) for both the takeoff and landing approach conditions. The wing loading was 2210 Pa (46.2 lb/ft²). The maximum (hot) thrust-weight ratio was about 0.31 for takeoff.

Improved stability was provided by longitudinal, lateral, and directional stability augmentation systems. However, the pilots generally rated the airplane as having low lateral and longitudinal stability.

STOL airplane operating procedures.- For the departures, the initial climb generally was made at an indicated airspeed V_1 of 90 knots to the initial altitude clearance (about 600 m (2000 ft)). The airplane was accelerated to 120 knots at this altitude and

the remainder of the climb was made at this speed. At the assigned cruise altitude (900 to 1530 m (3000 to 5000 ft)) the airplane was accelerated to 160 knots.

For the arrivals, descents to each of the specified clearance altitudes were made either at a prescribed location or on instructions from the controller. Slowup to 120 knots from 160 knots cruise speed was effected at about 5 n. mi. before intercept of the final approach course. The airplane was slowed to about 90 knots for intercept of the localizer. (For the approaches from the south, the airplane was slowed to about this speed for the 180° turn, see fig. 5.) At incipient glide-slope intercept, the airplane was slowed to 60 knots final approach speed by means of full flap deflection and rotation of the nozzles to a near-vertical angle. On the glide slope, approach speed adjustments were made by nozzle angle rotation and vertical flightpath control was effected by airplane pitch-attitude changes.

Experiments With STOL Runways at a CTOL Airport

In the first part of these experiments, various STOL runway configurations on an isolated CTOL airport were studied. The CTOL airport, referred to as Airport X, had the JFK runway layout (fig. 6). Three STOL dual-runway configurations considered to be the most meaningful and practicable (fig. 7) were simulated: an oblique angle configuration canted 30° to the active CTOL runway, a midfield in-line parallel configuration, and an L-shape parallel configuration. Each STOL runway configuration, with the exception of the in-line parallel, was tested with northwest and with southwest CTOL traffic flows. The independent CTOL and STOL routes serving these runways were established without consideration for terrain, obstructions, noise abatement, or adjacent airports (fig. 8). The routes shown were not fixed airway or area navigation routes but were basic guides for the controllers to use in visualizing the traffic flow while navigating the traffic by means of radar vectoring. For the arrivals, the controllers used speed and altitude control as well as radar vectoring for sequencing and spacing of traffic. For the departures, the controllers used altitude control and radar vectoring for spacing of traffic.

In the second part of these experiments, one STOL runway configuration at JFK was studied. The configuration selected was a dual separated parallel arrangement (fig. 9), one of two plans considered feasible by the New York Port Authority. The tests were made with southeast and with southwest CTOL traffic flows (fig. 10). CTOL traffic was basically controlled according to the most recent New York terminal area procedures. Some adjustments to the departure flows, controller airspace allotments, and altitude restrictions were necessary. The STOL traffic control methods included segregated and radar-monitored RNAV routes and speed control.

In both parts of the experiments, STOL airplanes entered the terminal control area at an altitude of 2430 m (8000 ft), except for the augmentor-wing STOL airplane which entered (with conventional jet transports) at 3060 m (10 000 ft) and the unpressurized Twin Otter which entered at 1230 m (4000 ft). Final altitudes for the STOL airplane departures varied from 1230 m (4000 ft) to 2730 m (9000 ft), depending on the route and the STOL airplane. In general, because of their high climb and descent rate capability, STOL airplanes were operated above the CTOL airplanes in crossing situations. However, because of the low cruising altitude of the Twin Otter (1230 m (4000 ft)), special coordination between controllers was necessary for crossing situations involving this airplane and climbing and descending CTOL traffic. Standard separation procedures were followed, except that a lateral separation of 914.4 m (3000 ft) between CTOL and STOL airplane final approach paths was considered acceptable for independent operations because of the vertical separation afforded by the steep glide slope used by the STOL airplanes.

STOL airplane characteristics.- The De Havilland Twin Otter and Buffalo airplanes simulated are both twin-engine turboprop airplanes equipped with constant-speed and variable-pitch propeller controls. Both airplanes have full-span double-slotted flaps and are capable of STOL operations. Pertinent characteristics of these airplanes are given in table I.

TABLE I.- PERTINENT CHARACTERISTICS OF SIMULATED STOL AIRPLANES

Characteristic	Airplane	
	Twin Otter	Buffalo
Passenger capacity	20	41
Crew	2	2
Weight, kN (lb)	53 (12 000)	178 (40 000)
Wing loading, kPa (lb/sq ft)	1.4 (29)	2.0 (42)
Takeoff shaft power at sea level, kW (hp)	972 (1304)	4564 (6120)
Maximum operating speed at sea level, knots	156	225
Flap extension speed limit, knots	102	124
Flaps full-extension speed limit, knots	95	100
Climb speed (best rate), knots	100	126
Final approach speed, knots	74	75
Landing gear	Fixed	Retractable

STOL airplane operating procedures.- For the departures, the initial climb was generally made at about the speed for best climb rates (see table 1) to the initial altitude clearance. For the Twin Otter, the initial altitude clearance was always to 1230 m (4000 ft) which was the cruise altitude for the majority of the departures; some departures, however, were made at a cruise altitude of 1530 m (5000 ft). For the Buffalo, the initial altitude clearance generally varied between 1230 m (4000 ft) and 1830 m (6000 ft). The second altitude clearance was generally to the cruise altitude of 2430 m (8000 ft). At cruise altitude, the airplanes were accelerated to cruise speed: 150 knots for the Twin Otter and 220 knots for the Buffalo.

For the arrivals, stepped descents from cruise altitude, involving several clearance altitudes and several reductions in speed, were made on instructions from the controllers. Generally the speed of the Buffalo was reduced from 200 knots to 160 knots before entry into the final approach control area (fig. 8); whereas, generally the speed of the Twin Otter was not reduced until in the final approach area. The pilots generally slowed the airplanes to 90 knots, or less, for acquisition of final approach guidance. The approach speeds used were higher on the average by 4 knots for the Twin Otter and 8 knots for the Buffalo than the prescribed approach speeds indicated in table I.

RESULTS AND DISCUSSION

The results of the two investigations are presented in figures 11 to 14. Pilots' comments and opinions are included in the discussions of operating problems.

Operating Problems

Downtown STOLport operations.- The operating procedures used in the downtown STOLport operations are illustrated in figure 11. Arrival operations were initially along the low-altitude airways and then along RNAV transition routes to the final approach course. Departure operations were initially along RNAV transition routes to the low-altitude airways. In these operations, a number of problems were experienced. In the initial flights, departures along the curved track (shown in fig. 11) using RNAV with way points about 3 n. mi. apart were found to be difficult to fly. The procedure used was to approximate the path by flying straight-line segments between the way points. The consensus of the pilots was that there were too many way points and that they were too close together. The procedure was changed to omit the middle way point in order to reduce the workload. Pilot opinion was that such tracks should be composed of straight segments and that way points should be at least 5 n. mi. apart.

In the initial arrivals from the southwest, the ATC descent altitude clearance was to 1000 m (3300 ft) and the requested speed reduction was to 140 knots at the beginning

of the 180° turn to final approach. (This turn had a radius of 1 n. mi.) Consequently for acceptable flight conditions for localizer intercept, the airplane had to be slowed to about 100 knots and had to descend to 700 m (2300 ft) in the turn. Having only RNAV and straight-in ILS guidance, the pilots made a standard-rate turn until a course was established to intercept the final approach course at a desired angle. The workload for these simultaneous operations of turning, descending, and speed reduction was continuously high. The procedure was first modified to a speed reduction to 100 knots for the turn. This constant speed value of 100 knots in the turn appeared to be acceptable for this powered-lift airplane which has an approach speed of 65 knots. The descending turn still proved to be difficult. The procedure was further modified to have a descent clearance of 700 m (2300 ft) before the start of the turn, which then made this part of the operation feasible but only at the expense of decreasing the altitude clearance relative to the Empire State Building to less than 230 m (800 ft).

Difficulty was still experienced in the approach because the final approach distance was so short (about 3 n. mi.) that localizer intercept and glide-slope intercept occurred almost simultaneously at the end of the turn. Localizer acquisition and slowing to approach speed (which involved conversion to powered-lift flight) were difficult to accomplish. More airspace for final approach was not available without infringing on the LGA approach airspace. Lower intercept altitudes were not feasible because of the clearance needed relative to the Empire State Building. To provide distance for localizer acquisition and transition to powered flight, pilots tended to extend the downwind leg by 1/2 to 1 n. mi. For such a limited airspace situation, the problems encountered indicate requirements for precise curved descending flightpath guidance capability in order to ensure safe altitude clearance and proper airspace usage. Also, such a situation indicates the requirement for development of a technique for conversion to powered-lift flight on the glide slope to avoid the difficulty of performing this conversion on the curved path. This result is in agreement with the results of reference 3 where conversion to powered-lift flight on the glide slope was found to be preferable to conversion prior to glide-slope intercept because both the pilot workload and the fuel used were reduced. The pilots also recommended that autospeed control and good handling qualities be provided in order that the workload be reduced to an acceptable level for this powered-lift airplane in the approach maneuver.

Airport operations.- The STOL operating procedures used for the canted runway configuration at Airport X are shown in figure 12. Departures were radar vectored until on course to a VOR station or RNAV way point. Arrivals were also radar vectored to provide, by use of path stretching, the sequencing of the traffic from the four directions for final approach. The arrival and departure routes shown are the nominal paths.

Some operating problems encountered in Airport X operations are illustrated in figure 13. Because of projected STOL airplane high rate of descent capabilities, the procedure adopted was to bring the STOL airplanes in over the CTOL airplane traffic (fig. 13(a)). In this method, the STOL airplane arrivals from the north and east were brought in over the CTOL airplane traffic which was on simultaneous final approach to the parallel runways at Airport X. The result was that steep descent maneuvers were required. For example, STOL airplane traffic from the east was held at an altitude of 2130 m (7000 ft) over downwind CTOL airplane arrival traffic and then was allowed to descend only to 1360 m (4500 ft) while crossing the final approach traffic. Another steep descent maneuver was thus required to intercept the glide slope at 900 m (3000 ft). The controllers often requested that the descent to 900 m (3000 ft) be made at the maximum descent rate. Rates of descent up to 600 m/min (2000 ft/min) were measured. With such high descent rates cabin pressurization is needed to avoid passenger ear discomfort. Because of the critical nature of starting each descent maneuver at the proper point and ending at the designated altitude and point and because of the required high steepness of the descents, the pilots pointed out that the use of three-dimensional RNAV procedures in such a situation would be beneficial from safety and workload considerations.

In sequencing final approach traffic from the four directions, the controllers often had to request numerous heading and speed changes in the final control area. Examples of two arrival paths are shown in figure 13(b). Arrival 1 from the south, an extreme example, underwent eight radar vector heading changes and six airspeed changes in the sequencing process. Arrival 2, a more usual example, underwent four heading changes and two airspeed changes. In addition to the requests for heading and airspeed changes, up to three altitude reassignments were often received in the final control area; the average number of altitude reassignments was about $1\frac{1}{2}$.

In addition to the numerous maneuvers experienced in the sequencing process, length sequencing maneuvers were sometimes required. An extreme example is shown in figure 13(c) for an approach from the south for a wind situation requiring an approach to runway 16 of the STOL runway configuration. The time for this arrival from a point 30 n. mi. south of the airport was 22 min (a block speed of about 80 knots). The airplane was slowed to 140 knots adjacent to the airport on the downwind leg. The downwind leg was extended to about 10 n. mi. north of the runway. Speed was reduced to 80 knots at the turn to final approach. The time on final approach was about 7.5 min. Pilots expressed a desire for a shorter maneuver by a reduction of speed on the downwind leg — that is, more use of speed control rather than path stretching for the sequencing process.

In the foregoing discussion of the operating problems at Airport X, the examples used were based on operations with the canted runway configuration. The same problems

generally existed in the operations with the in-line parallel and L-shape parallel runway configurations, although the length and number of sequencing maneuvers tended to be somewhat smaller especially for the in-line parallel configuration.

Only a few operations with the dual separated runway configuration at JFK (fig. 9) were obtained. For these operations, the number and length of sequencing maneuvers were considerably less than those in the Airport X operations; however, this probably occurred because the controllers had to sequence STOL airplanes from only two directions instead of four directions.

General problems.- The problems discussed in connection with figures 11 and 13 often resulted in high workloads for the crew and in increases in flight time compared with the optimum flight time. (Time penalties for maneuvering in the ATC system are discussed in a subsequent section.) In addition to the problems illustrated, vertical flightpath control of the Twin Otter and Buffalo airplanes was considered to be marginal on the 7° and 7.5° glide slopes used. Once established on the glidepath, the pilots could maintain the path with no external disturbances. However, it was found to be essential that the airspeed and airplane configuration be established before glide-slope intercept in order to ensure capture of glide slope. No significant difference in operating problems was found between the Twin Otter and Buffalo airplanes.

Time Penalties

The range and average values of maneuver time for departures and arrivals in the downtown STOLport and CTOL airport environments are given in figure 14. Maneuver time is the additional time required in the ATC system relative to the time for an unrestricted straight climbout or descent. The time comparisons were made for a straight-line distance of 50 n. mi. for both the departures and arrivals. Maneuver time thus indicates the time penalty of altitude restrictions connected with traffic separation and with ATC handoff procedures, of speed restrictions and radar vectoring for traffic sequencing, of indirect routings required in the use of the airways system, and of maneuvers to and from the runway in use.

For the departures from the downtown STOLport (fig. 14(a)), the average maneuver times were about 3 min where the summation of the heading changes required by the nominal paths after takeoff was small ($\Sigma\psi \approx 0^{\circ}$) and about 6 min where the summation of the heading changes was large ($\Sigma\psi \approx 180^{\circ}$); the penalties ranged from about 2 to 7 min. At the CTOL airport, the maneuver times for the Buffalo and Twin Otter airplanes averaged 2 and 3 min, respectively, and ranged from about 0 min for departures with small heading changes to about 7 min for departures with large heading changes. (Insufficient data were obtained to allow analysis of the effect of heading changes.)

For the arrivals at the downtown STOLport (fig. 14(b)), the average maneuver times were the same as those for the departures, that is, about 3 min where the summation of the heading changes required by the nominal paths was small ($\Sigma\psi \approx 0^\circ$) and about 6 min where the summation of the heading changes was large ($\Sigma\psi \approx 180^\circ$). At the CTOL airport, however, the average maneuver times for the arrivals were larger than those for the departures. Arrival maneuver times for the Twin Otter averaged about 6 min and ranged from 3 to 9 min. (Insufficient data were obtained for this operation to allow analysis of the effect of heading change.) For the Buffalo, the maneuver times averaged about 5 min for arrivals where $\Sigma\psi$ was from 0° to 123° and about 10 min for arrivals where $\Sigma\psi$ was from 123° to 230° . (In arrivals, the heading changes are those for the nominal paths within the final approach control area.) The arrival maneuver times at the airport ranged from about 1 to 15 min. The range of maneuver times for the Twin Otter is smaller than that for the Buffalo probably because the data sample obtained with the Twin Otter is smaller.

CONCLUDING REMARKS

The operating problems and equipment requirements for STOL airplanes in terminal area operations in simulated air traffic control (ATC) environments were studied. These studies consisted of Instrument Flight Rules (IFR) arrivals and departures in the New York area to and from a downtown STOLport, STOL runways at John F. Kennedy International Airport, or STOL runways at a hypothetical international airport. The studies were accomplished in real time by using a STOL airplane flight simulator and the Federal Aviation Administration ATC simulation facilities. The flight simulator was operated by government research pilots and airline crews and the ATC simulator was operated by experienced air traffic controllers. An experimental powered-lift STOL airplane and two in-service airplanes having high aerodynamic lift (i.e., STOL) capability (De Havilland Twin Otter and Buffalo) were used in the simulations.

In the severely limited airspace of downtown operations with the experimental powered-lift STOL airplane, departures along curved tracks having way points about every 3 n. mi. were difficult to fly. Way points spaced this closely created a high navigation workload. Pilot opinion was that such tracks should be composed of straight segments with way points at least 5 n. mi. apart. For arrivals along horizontally curved descending tracks, the navigation workload was high with only simple area navigation (RNAV) and straight-in instrument landing system (ILS) guidance. Precise horizontally curved descending flightpath guidance for obstacle clearance and proper airspace usage was found to be a requirement. Because of limited airspace, development of a technique for conversion to powered-lift flight after glide-slope acquisition was indicated to avoid the difficulty of conversion on the curved path. The pilots also recommended that auto-

speed control and good handling qualities be provided in order to reduce the workload to an acceptable level for this powered-lift airplane in the approach maneuver.

In airport operations, maneuvers required for traffic separation and for sequencing often resulted in high workloads for the crew. Steep descent maneuvers, requested on entering the final approach control area and for descent to glide-slope intercept altitude, together with precise navigation requirements indicated a need for three-dimensional RNAV procedures. In the final control area, numerous heading, speed, and altitude changes were experienced in sequencing and spacing operations, the average number of maneuvers required (based on arrivals from the four cardinal points) being four heading, two airspeed, and one or two altitude changes. Lengthy sequencing maneuvers also added to the crew workload. For the Twin Otter and Buffalo airplanes, vertical flightpath control was considered to be marginal on the 7° and 7.5° glide slopes used.

At the downtown STOLport, average time penalties connected with operation in the ATC system varied from 3 to 6 min for both departures and arrivals, depending on the heading changes required. In the CTOL airport environments, average time penalties were from 2 to 3 min for the departures and from 5 to 10 min for the arrivals, depending on the heading changes required.

Langley Research Center,
National Aeronautics and Space Administration,
Hampton, Va., August 15, 1974.

REFERENCES

1. Rossiter, Sidney B.; Maurer, John; and O'Brien, Paul J.: ATC Concepts for V/STOL Vehicles - Parts 1 and 2. Rep. No. FAA-RD-73-47, Apr. 1973.
2. Quigley, Hervey C.; Sinclair, S. R. M.; Nark, Theodore C., Jr.; and O'Keefe, Jack V.: A Progress Report on the Development of an Augmentor Wing Jet STOL Research Aircraft. [Preprint] 710757, Soc. Automot. Eng., Sept. 1971.
3. Morello, Samuel A.; Person, Lee H., Jr.; Shanks, Robert E.; and Culpepper, Richard G.: A Flight Evaluation of a Vectored-Thrust-Jet V/STOL Airplane During Simulated Instrument Approaches Using the Kestrel (XV-6A) Airplane. NASA TN D-6791, 1972.

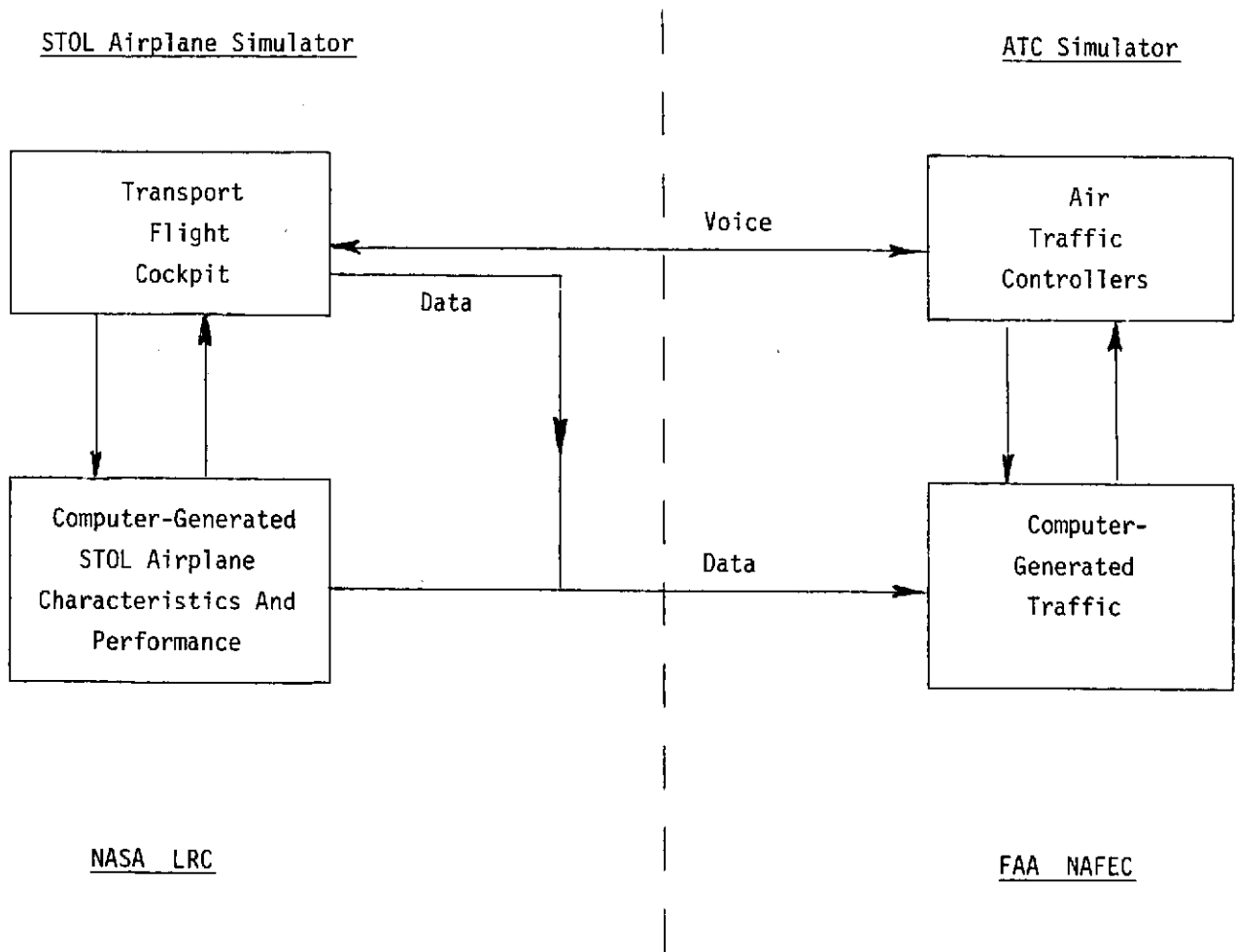

Figure 1.- Simulation facilities and interconnections.

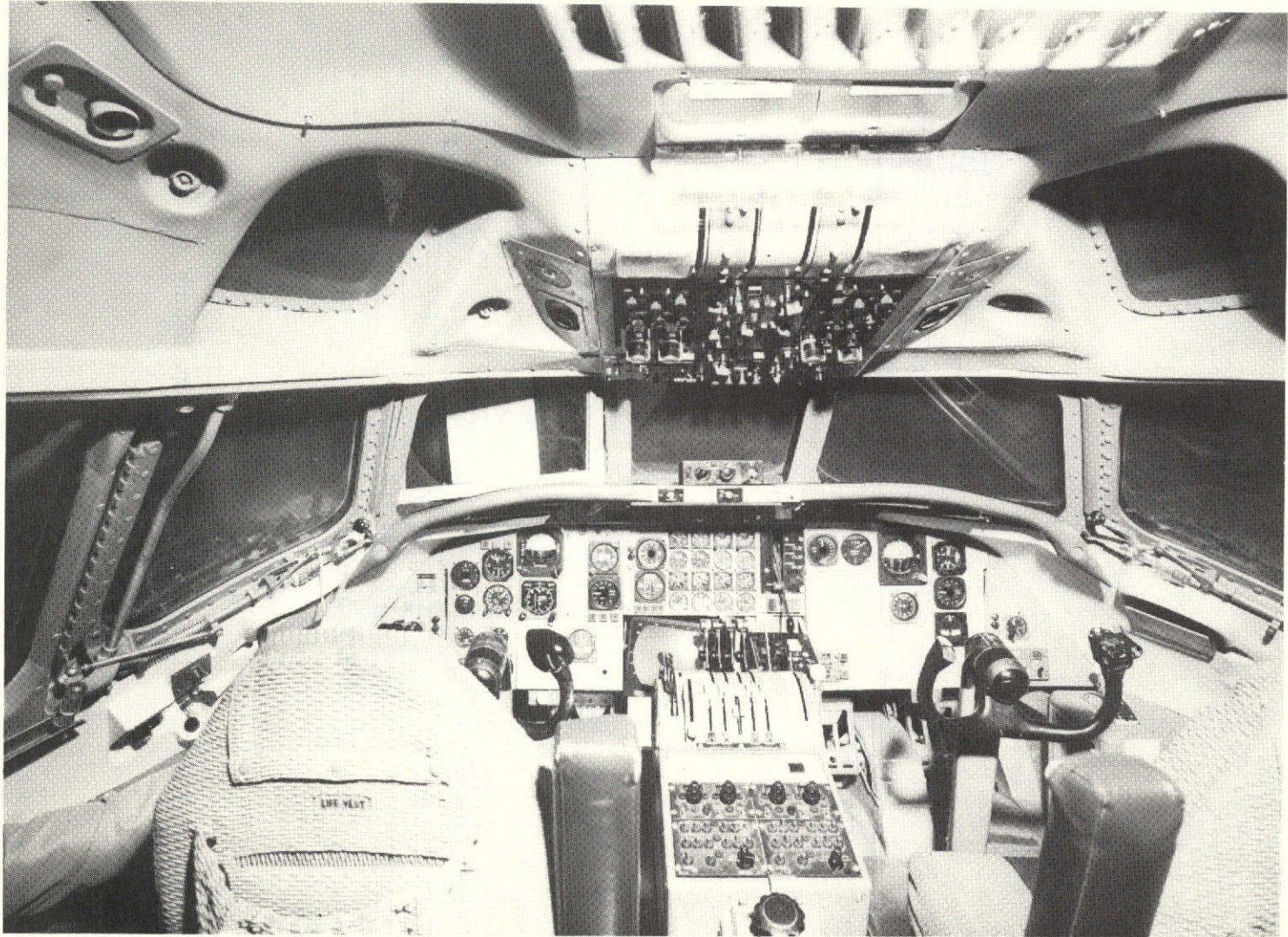
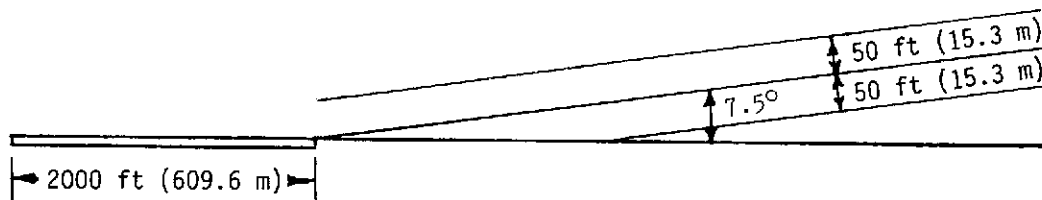
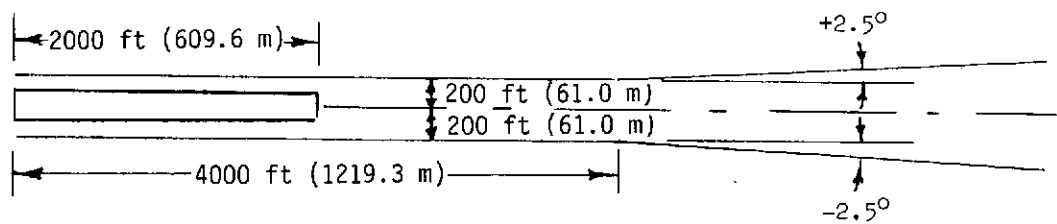

Figure 2.- Fixed-base STOL simulator cockpit at Langley Research Center.

L-72-3813



(a) Glide slope.



(b) Localizer.

Figure 3.- Localizer and glide-slope beams.

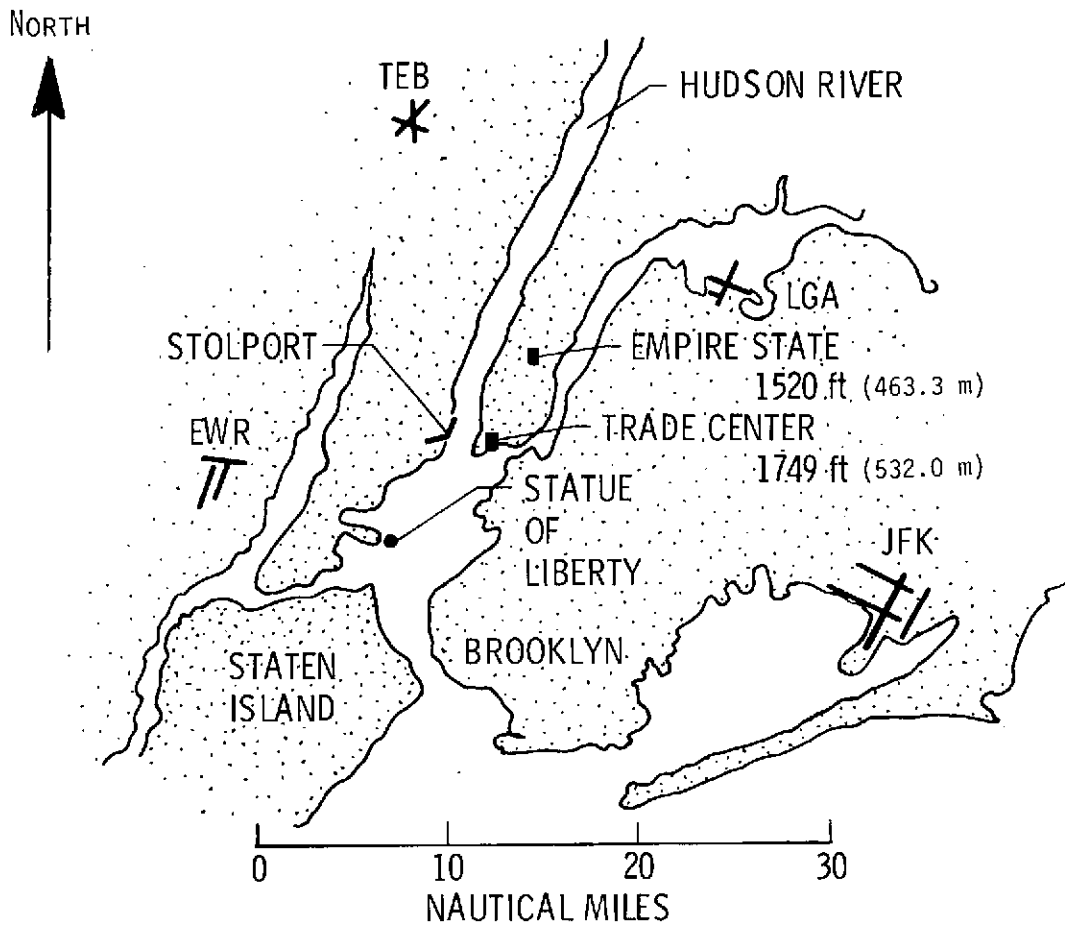
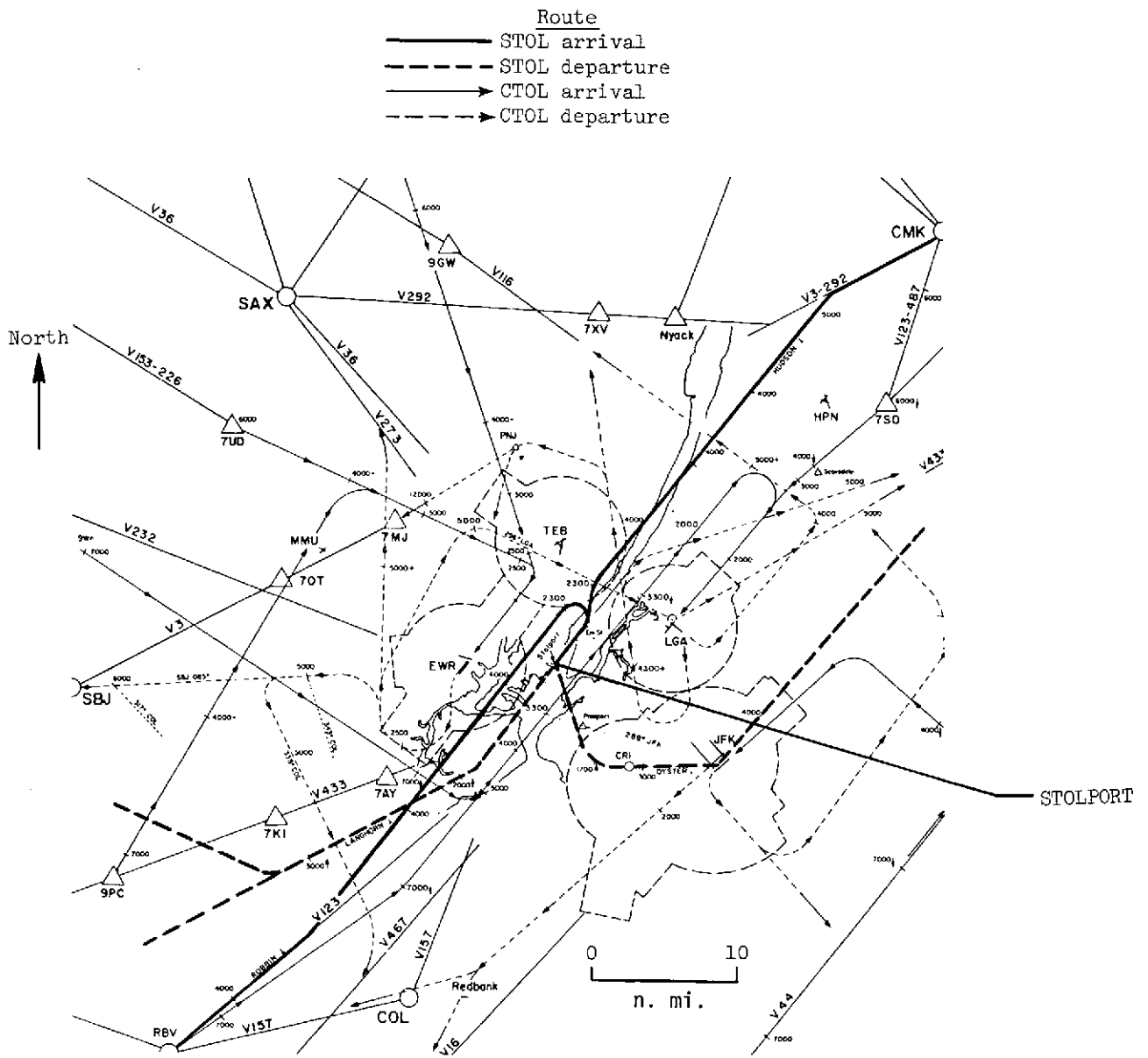

Figure 4.- Downtown STOLport.



(a) Southwest traffic flow.

Figure 5. - STOL and CTOL airplane terminal area routes for downtown STOLport in New York area.

Route
 ——— STOL arrival
 - - - STOL departure
 ———> CTOL arrival
 - - -> CTOL departure

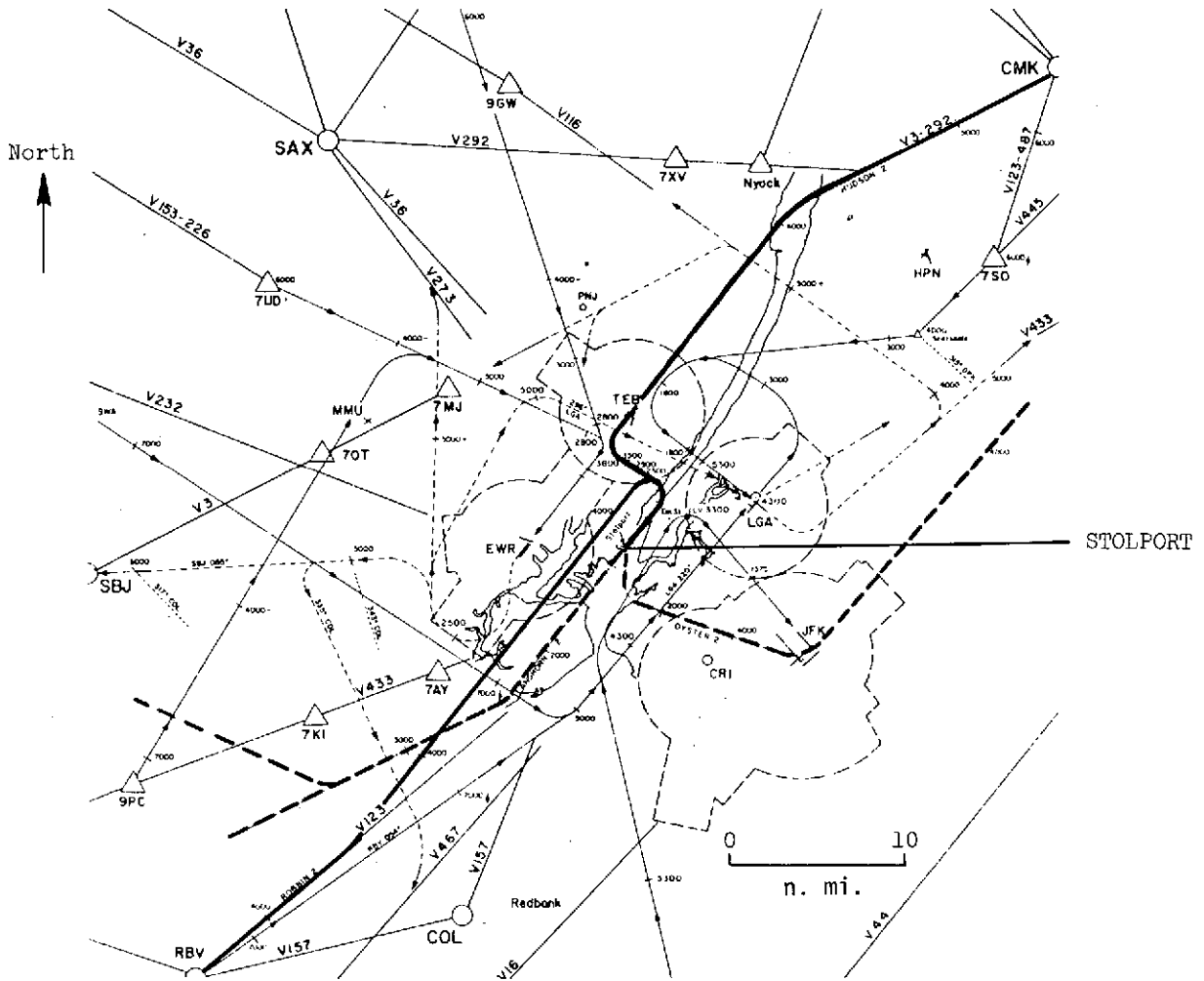

(b) Southeast traffic flow.

Figure 5.- Continued.

REPRODUCIBILITY OF THE ORIGINAL PAGE IS POOR

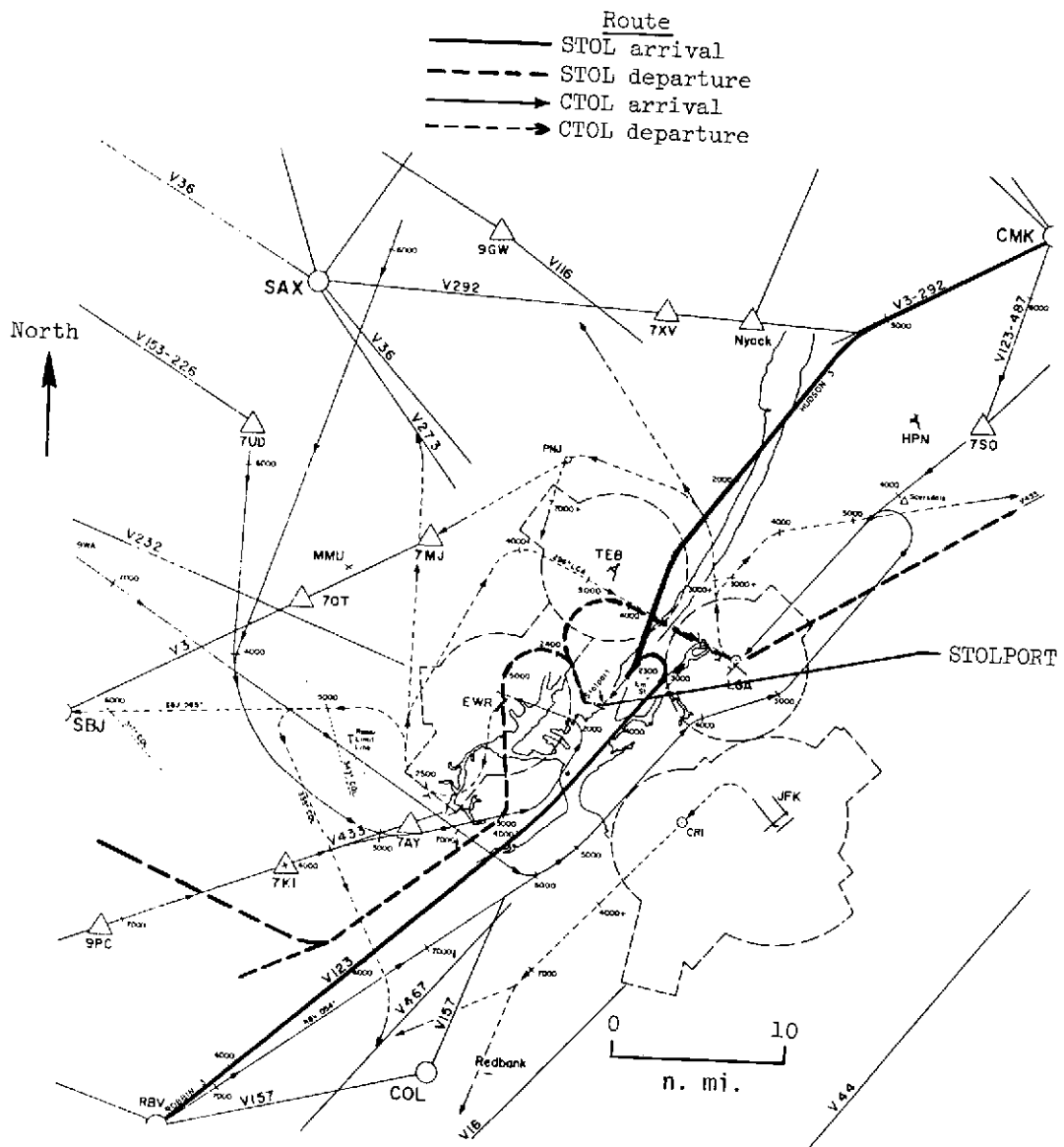

(c) West traffic flow.
Figure 5.- Concluded.

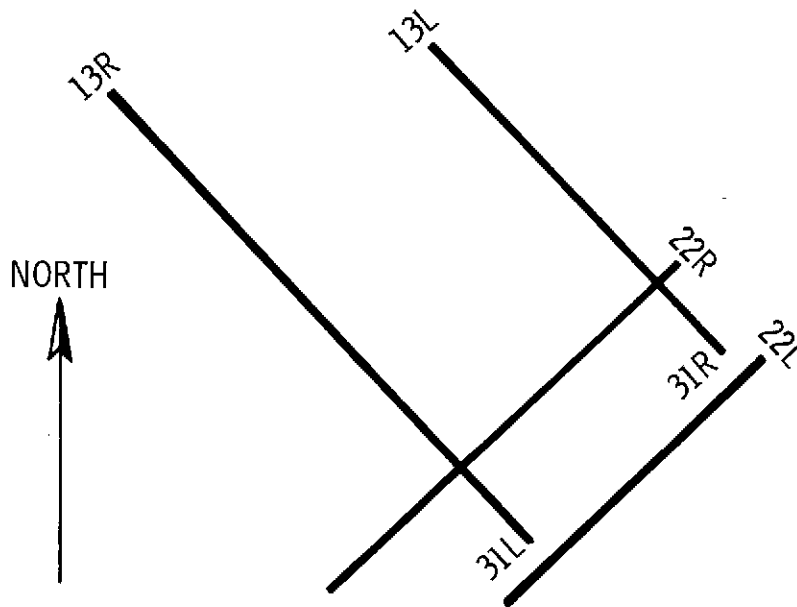

Figure 6.- Airport X runway layout.

REPRODUCIBILITY OF THE
ORIGINAL PAGE IS POOR

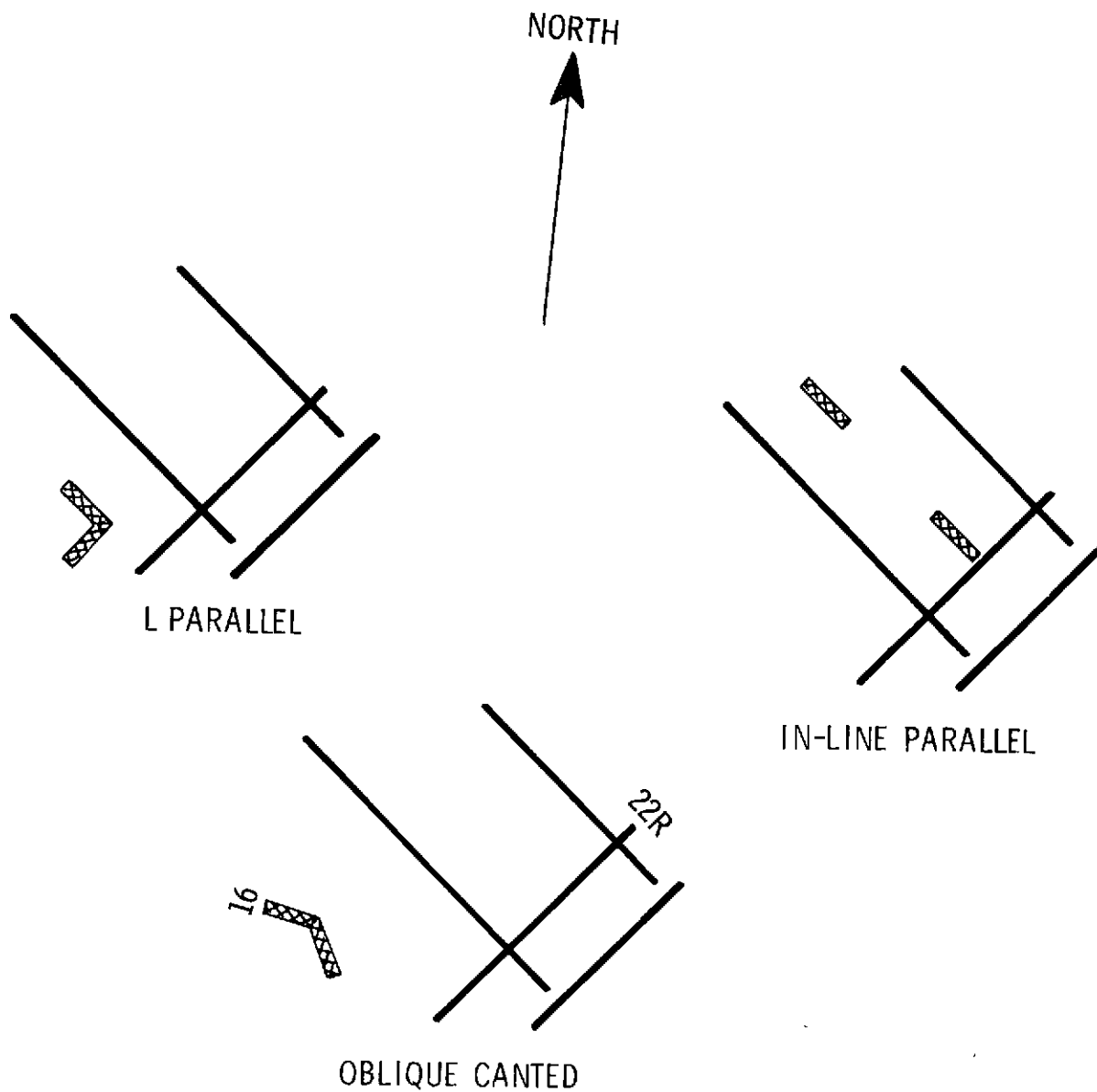
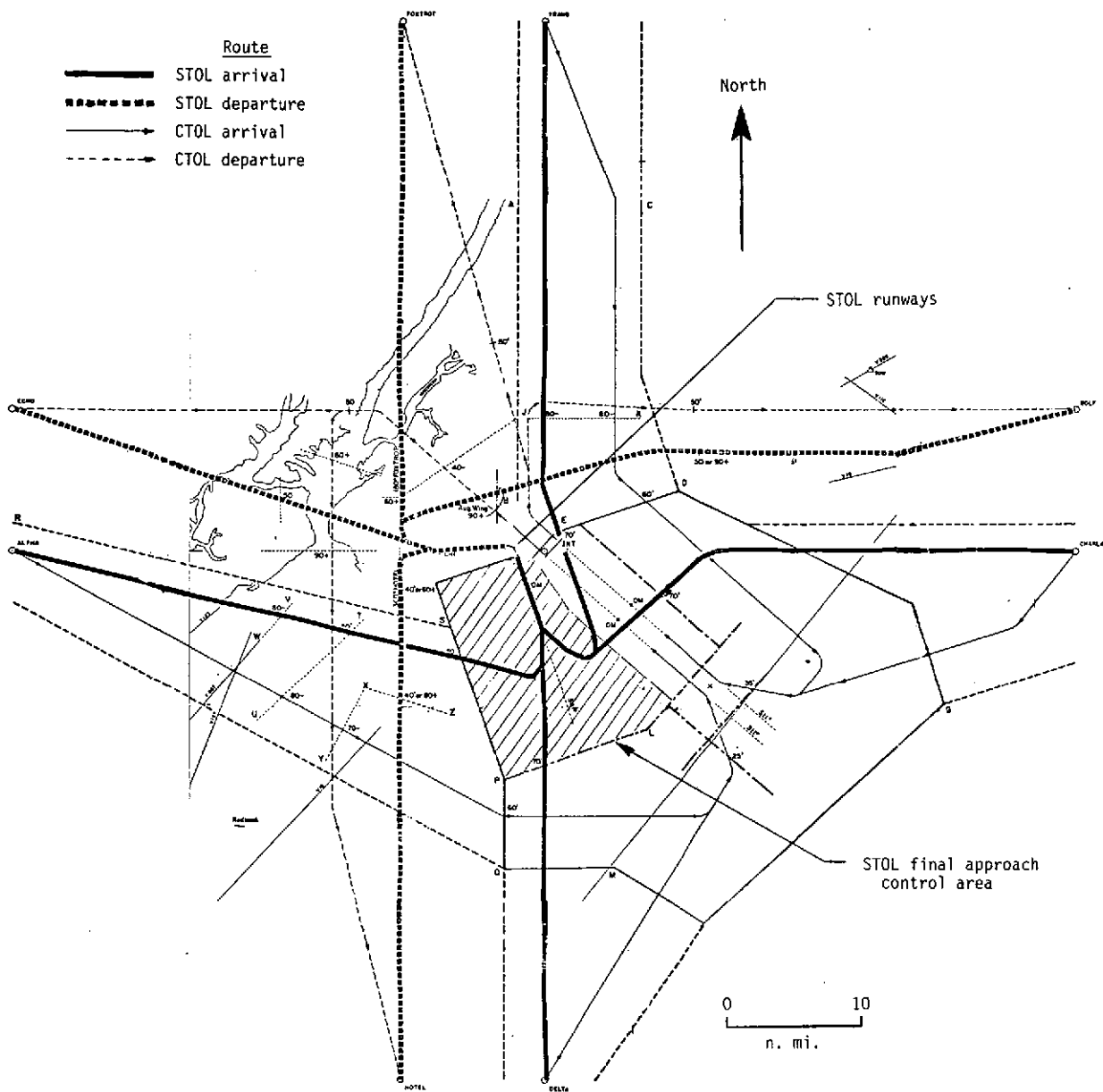

Figure 7.- Three STOL dual-runway configurations relative to Airport X runway layout.



(a) Canted STOL runway configuration, northwest traffic flow.

Figure 8.- Terminal area routes for three STOL runway configurations at a CTOL airport.

REPRODUCIBILITY OF THE ORIGINAL PAGE IS POOR

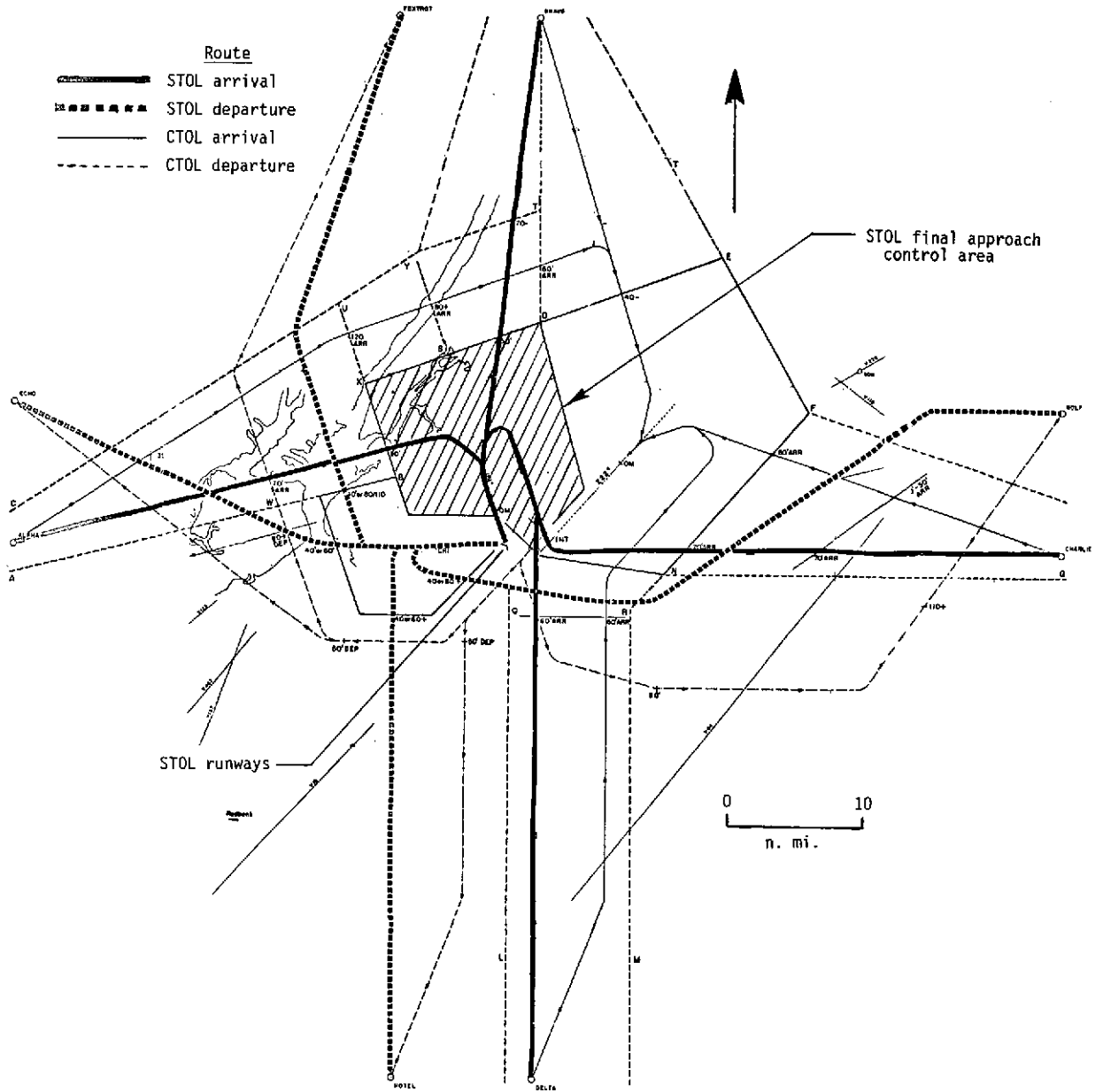

(b) Canted STOL runway configuration; southwest traffic flow.

Figure 8.- Continued.

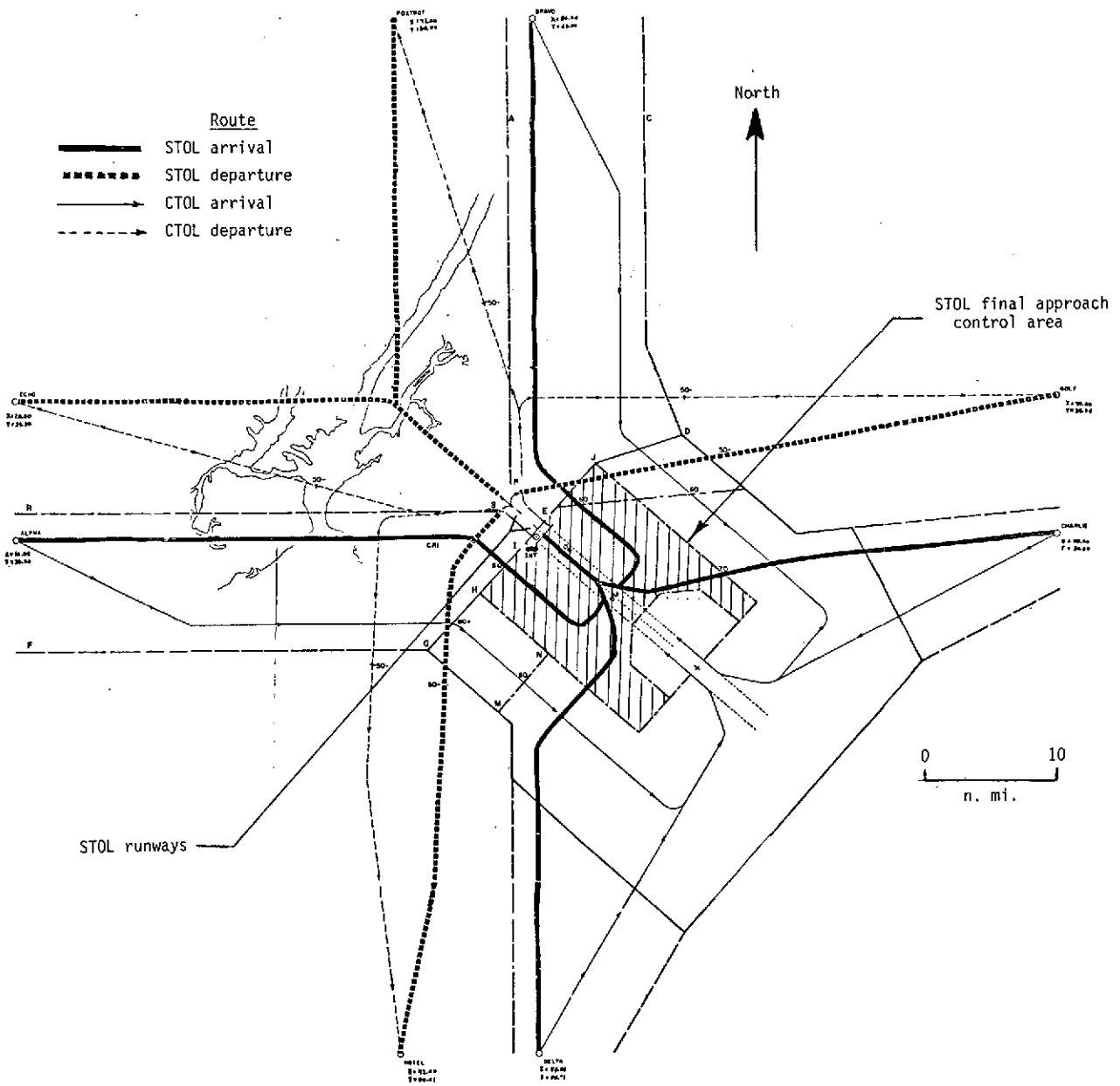

(c) In-line midfield STOL runway configuration; northwest traffic flow.

Figure 8.- Continued.

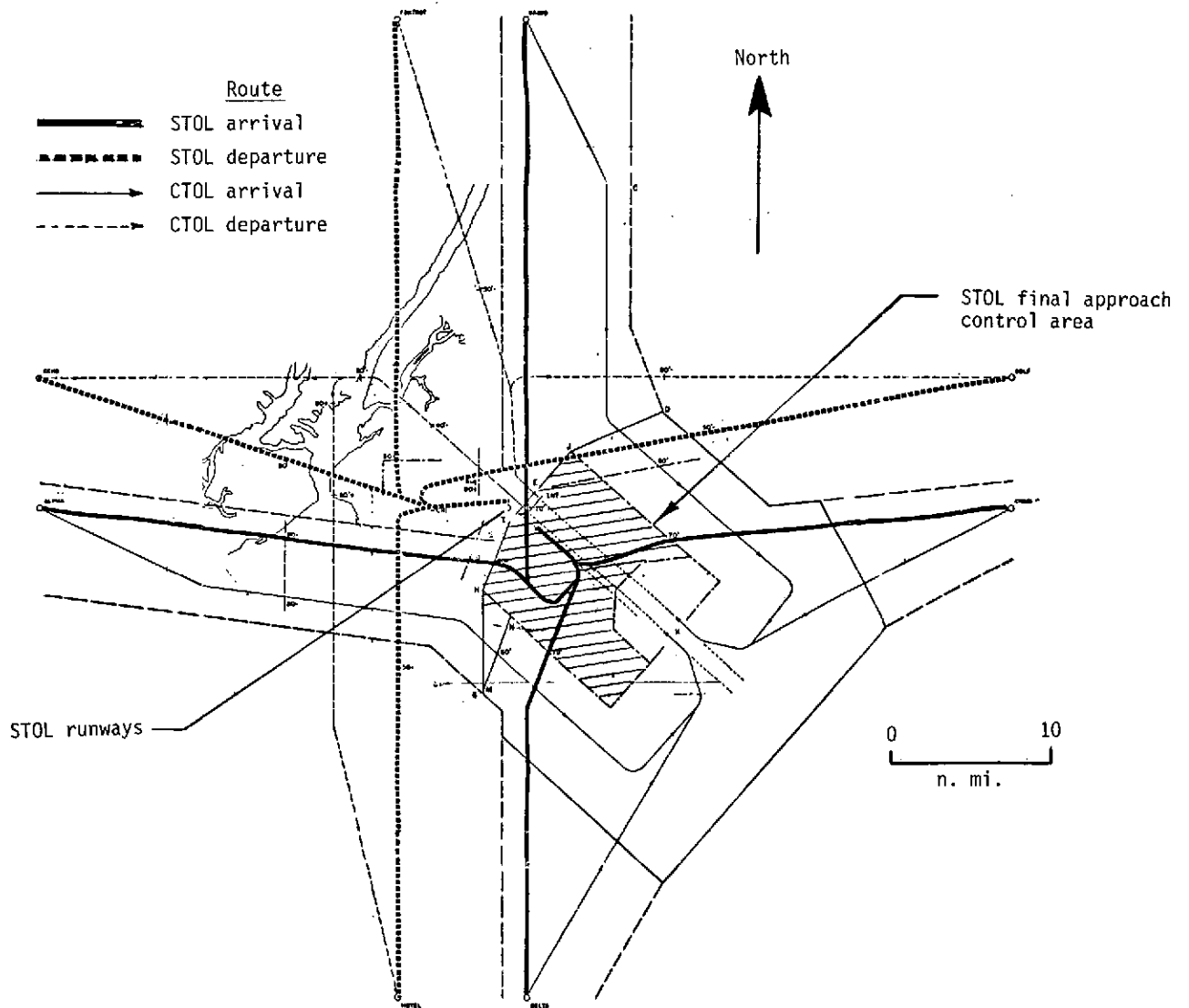

(d) L-shape STOL runway configuration; northwest traffic flow.

Figure 8.- Continued.

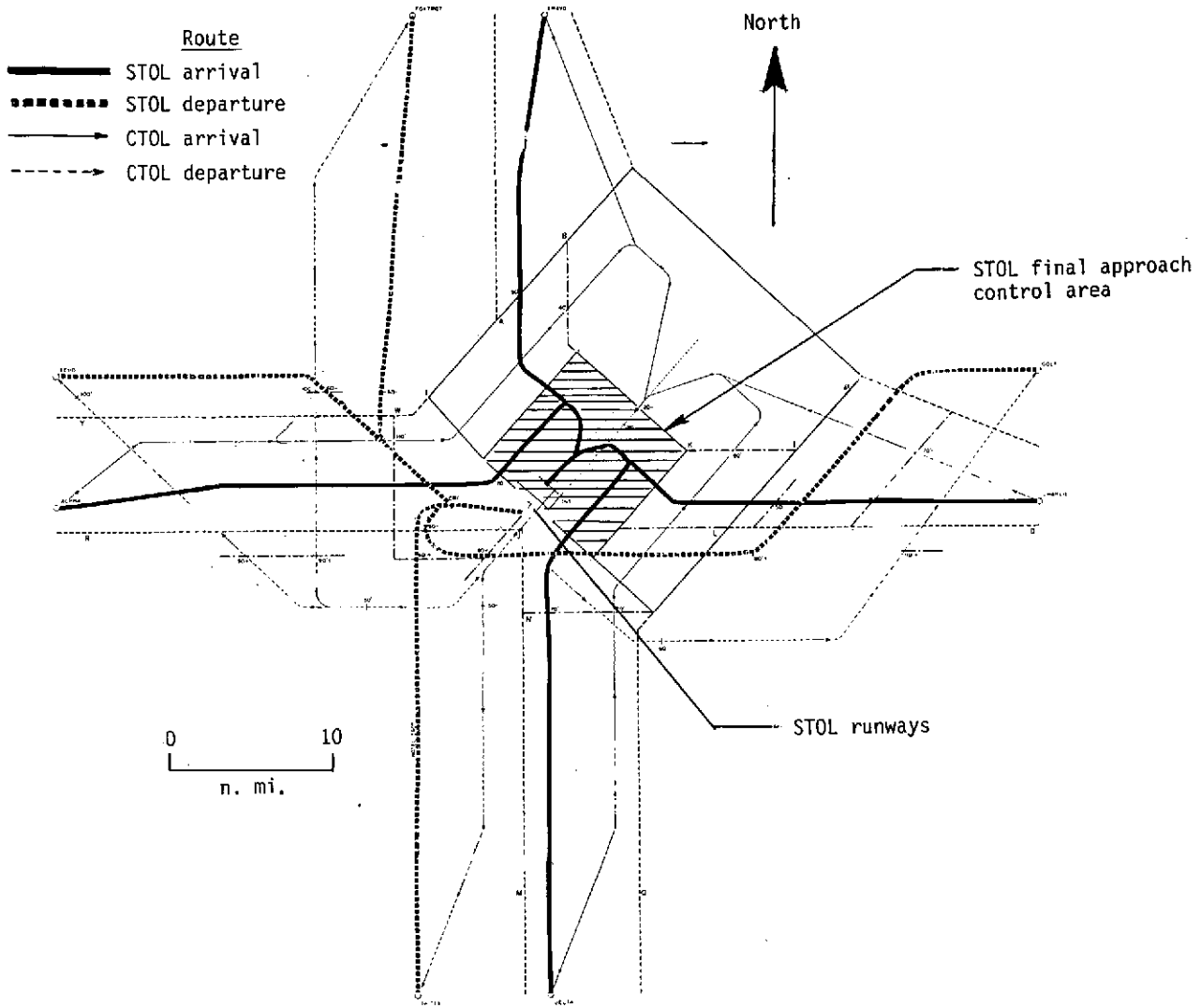

(e) L-shape STOL runway configuration; southwest traffic flow.

Figure 8.- Concluded.

REPRODUCIBILITY OF THE ORIGINAL PAGE IS POOR

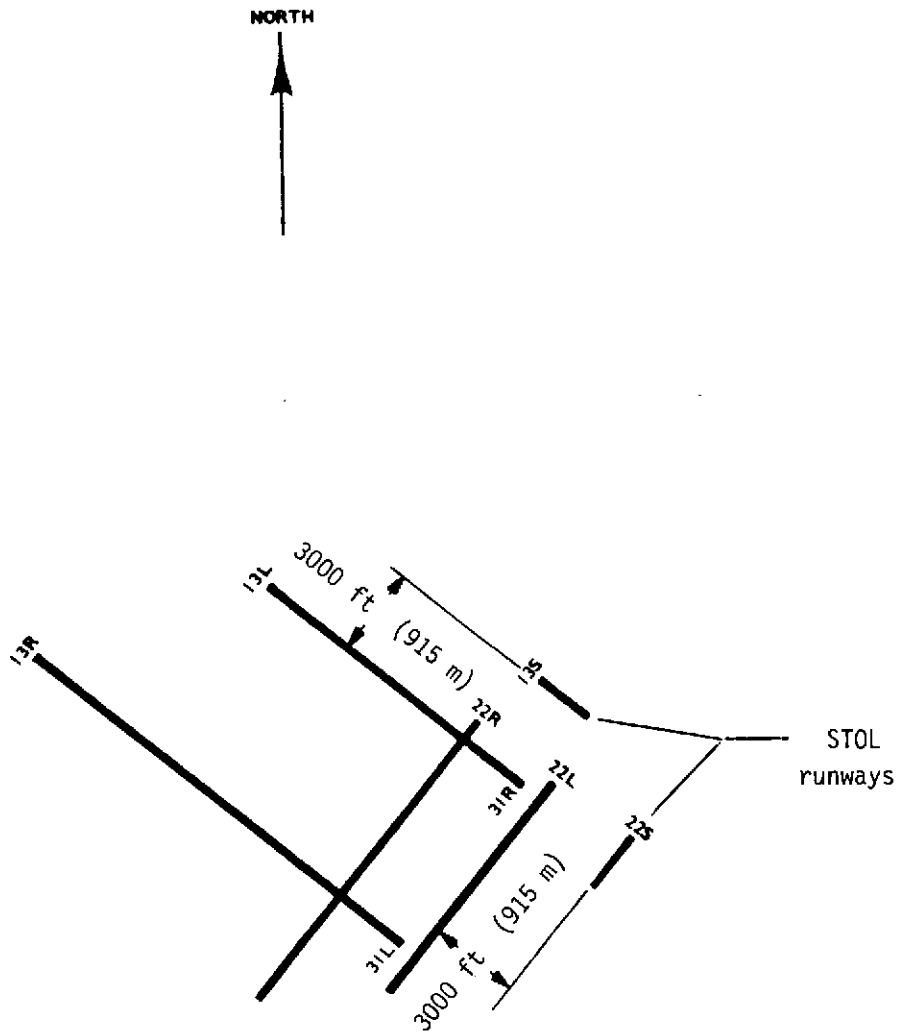
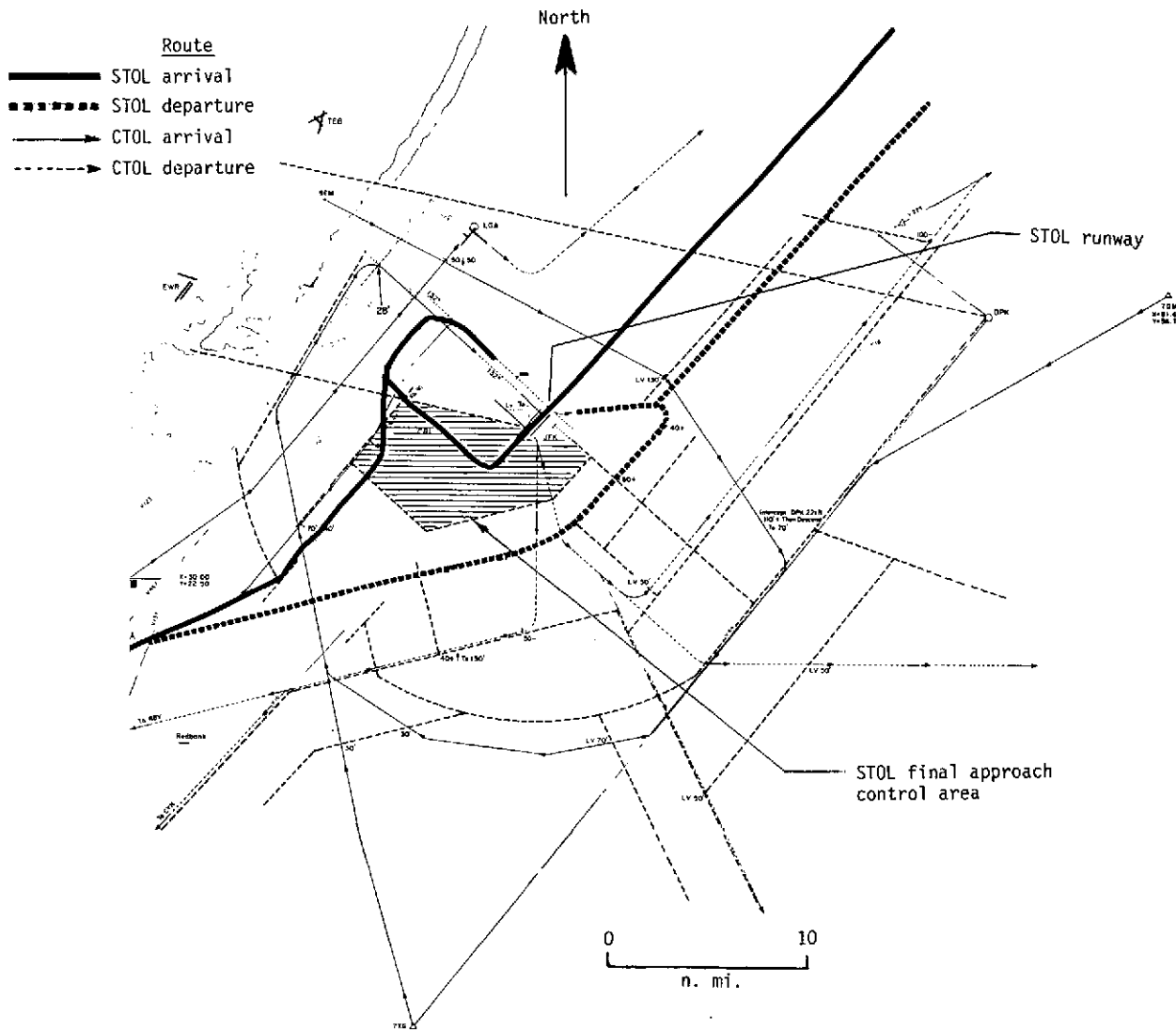

Figure 9.- Simulated STOL runways at JFK .



(a) Southeast traffic flow.

Figure 10.- Terminal area routes for simulated STOL runways at JFK.

REPRODUCIBILITY OF THE
ORIGINAL PAGE IS POOR

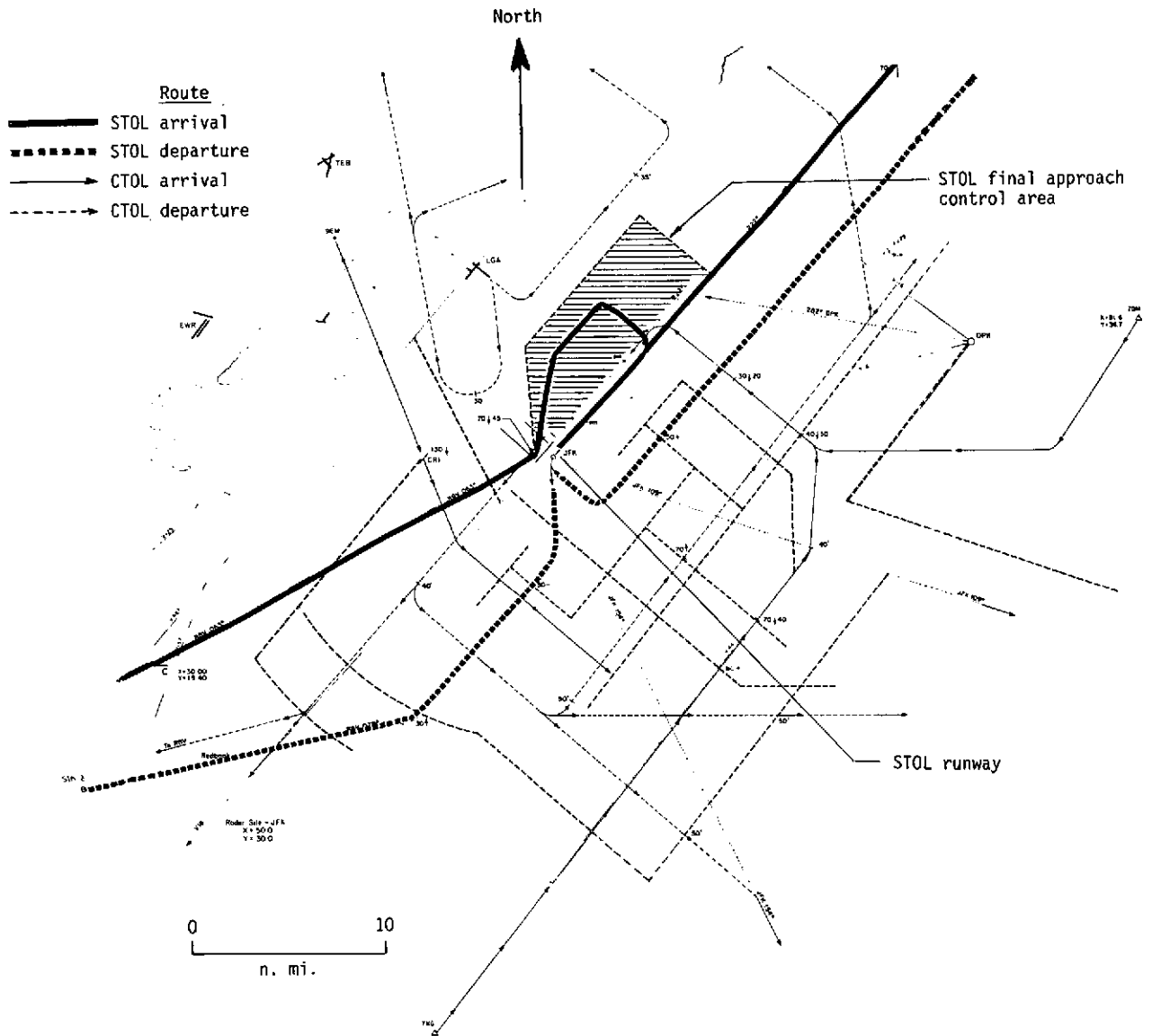

(b) Southwest traffic flow.

Figure 10.- Concluded.

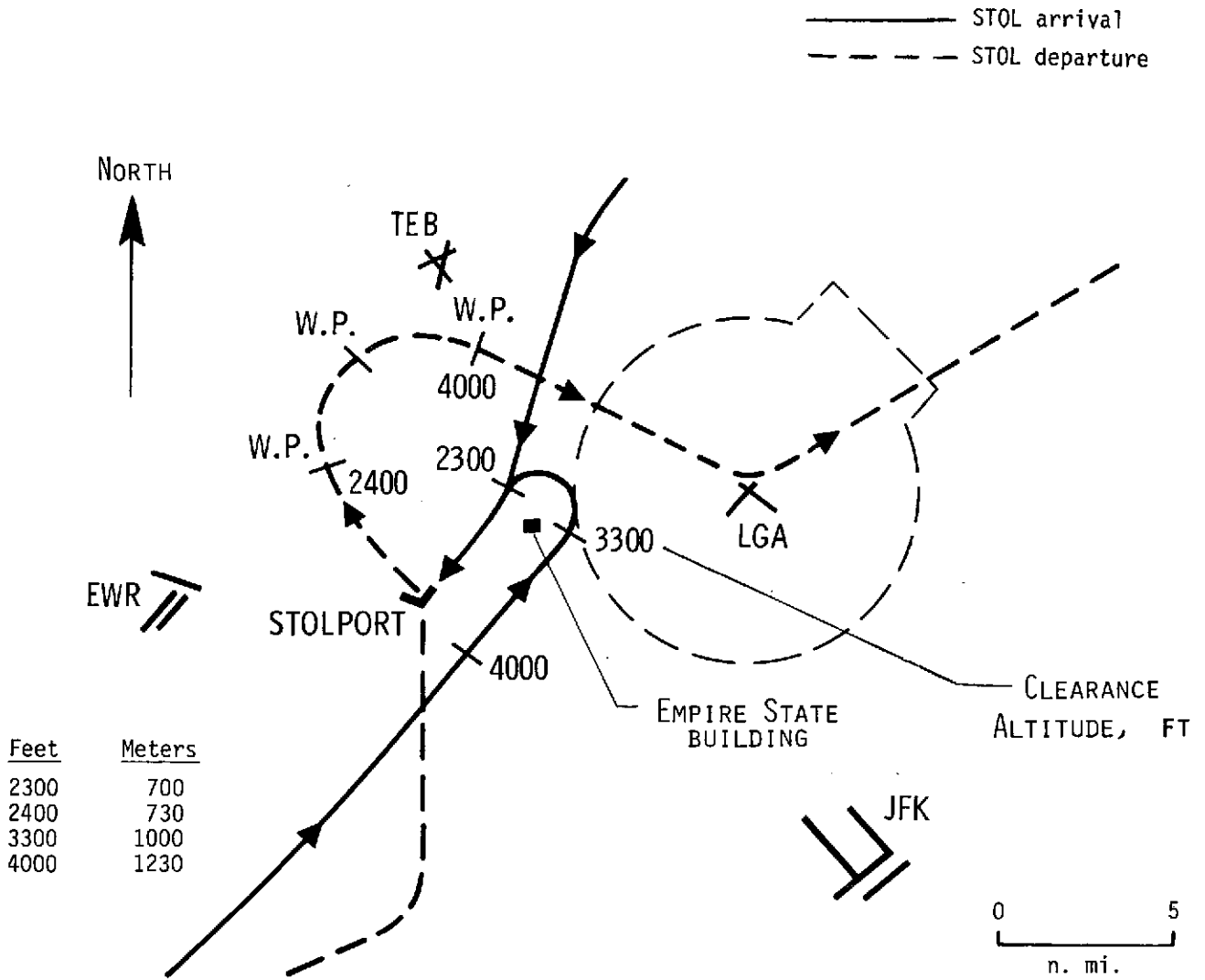

Figure 11.- STOL airplane operations at New York downtown STOLport.

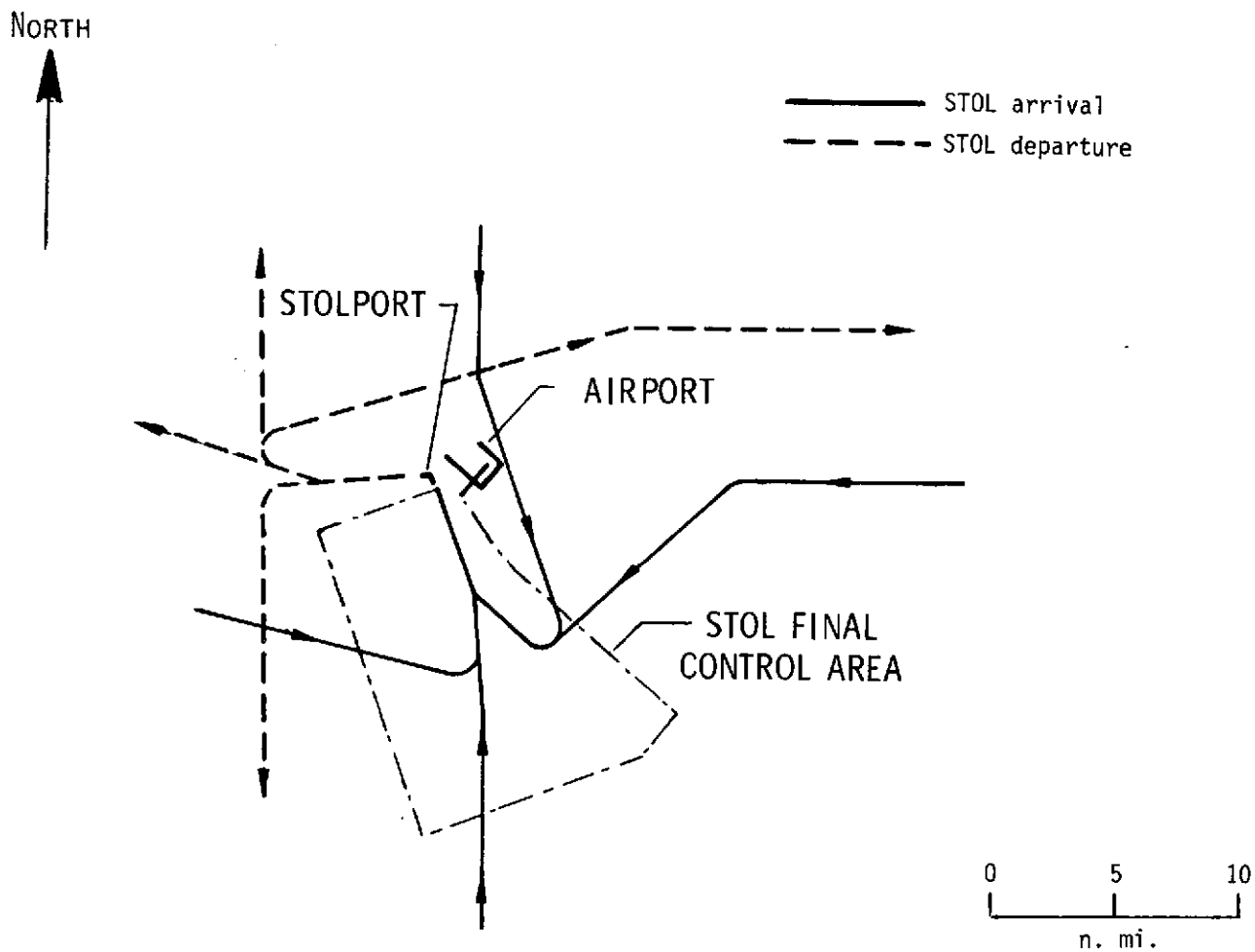
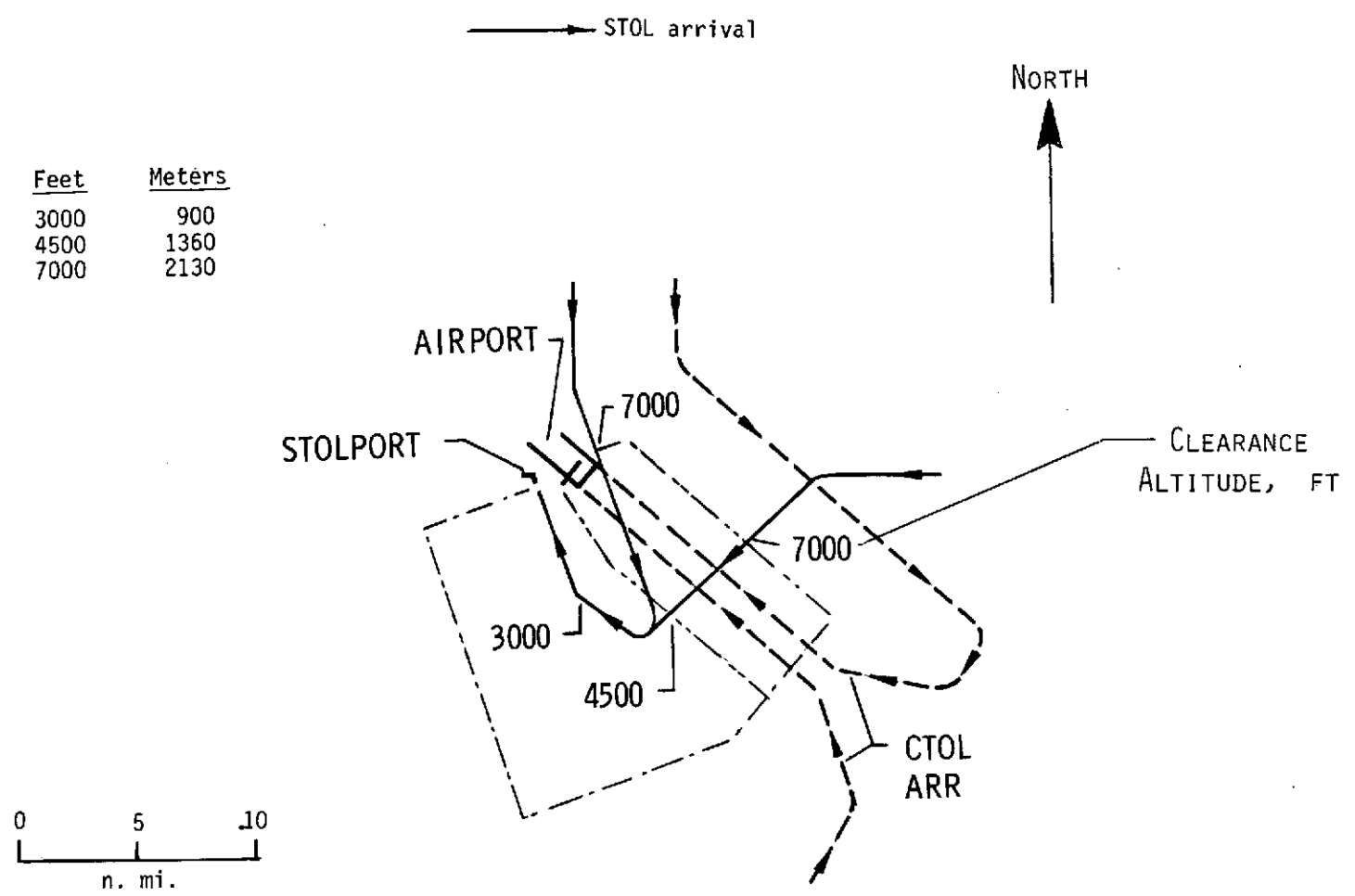
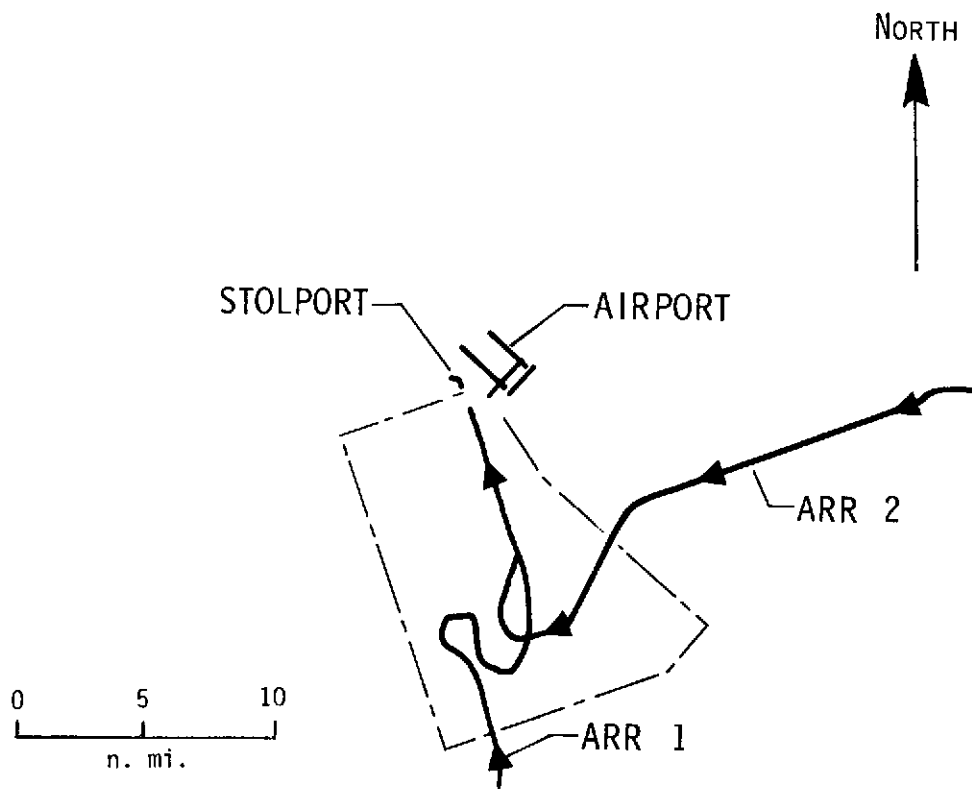

Figure 12.- STOL airplane operating procedures at Airport X.



(a) Steep descent maneuvers.

Figure 13.- STOL airplane operations at Airport X.



(b) Numerous maneuvers for sequencing.

Figure 13.- Continued.

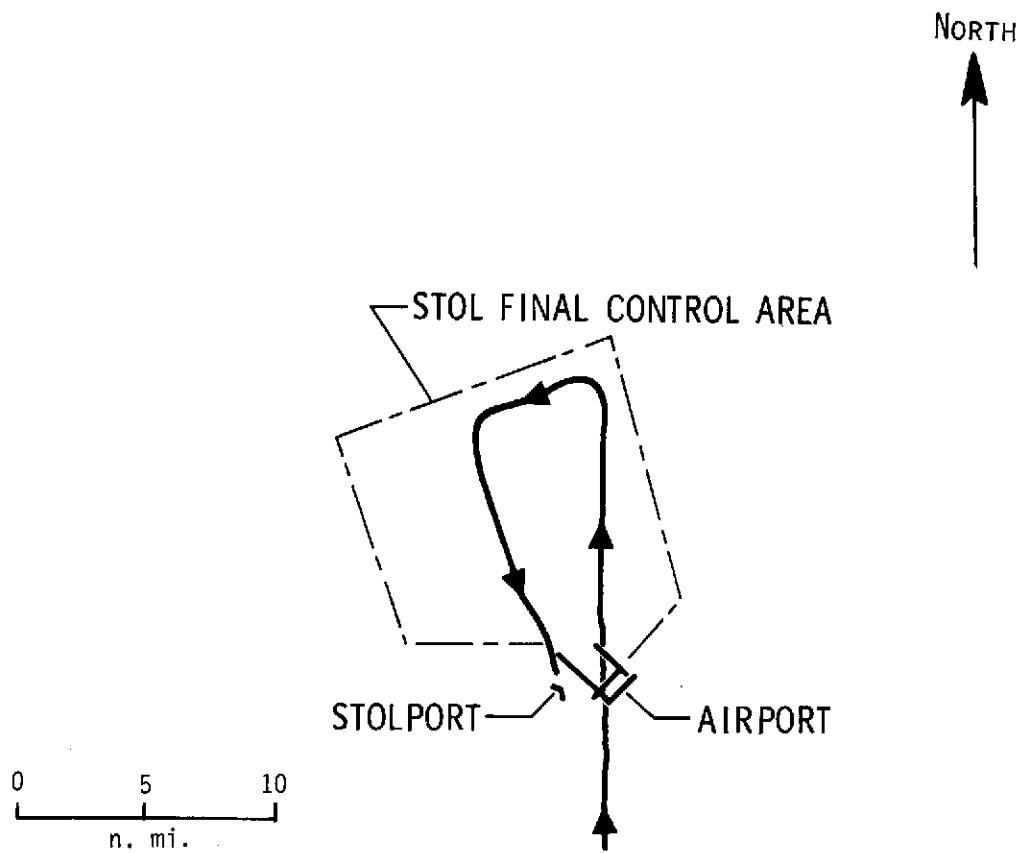

(c) Lengthy sequencing maneuvers.

Figure 13.- Concluded

**REPRODUCIBILITY OF THE
ORIGINAL FILE IS POOR**

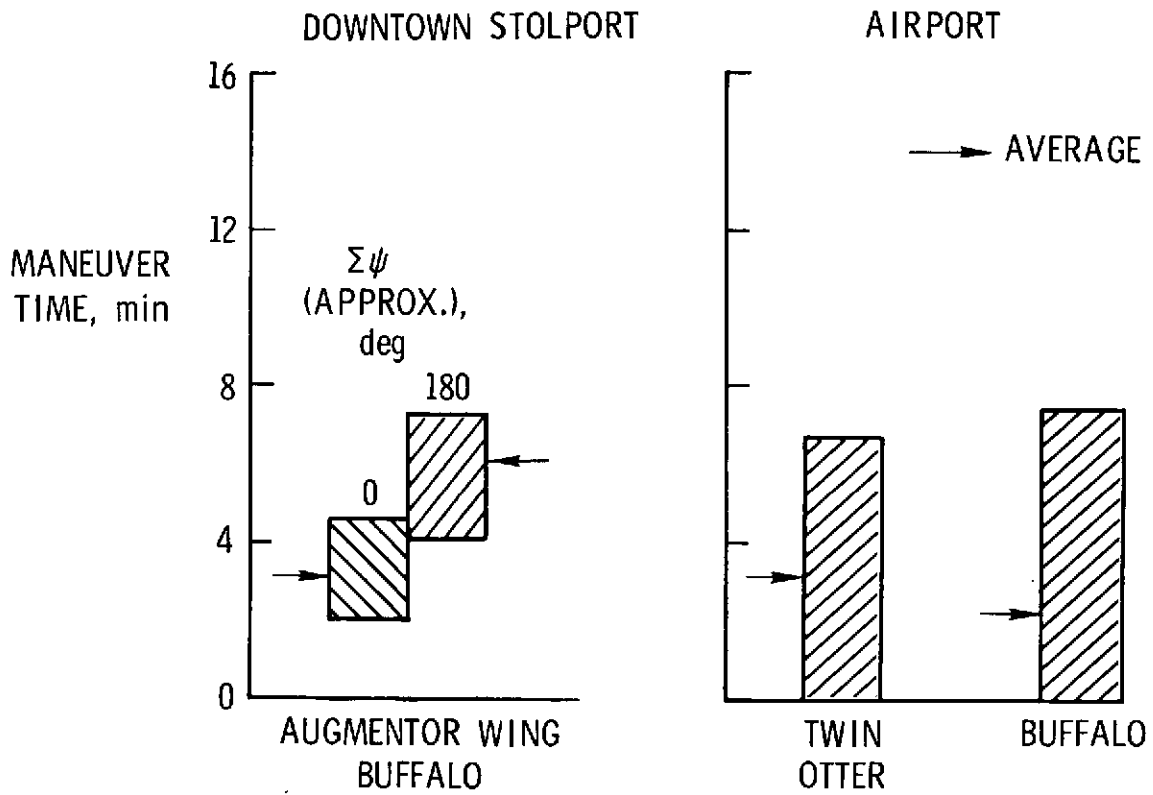

(a) Departures.

Figure 14.- Maneuver time for STOL airplane departures and arrivals in downtown STOLport and CTOL airport environments.

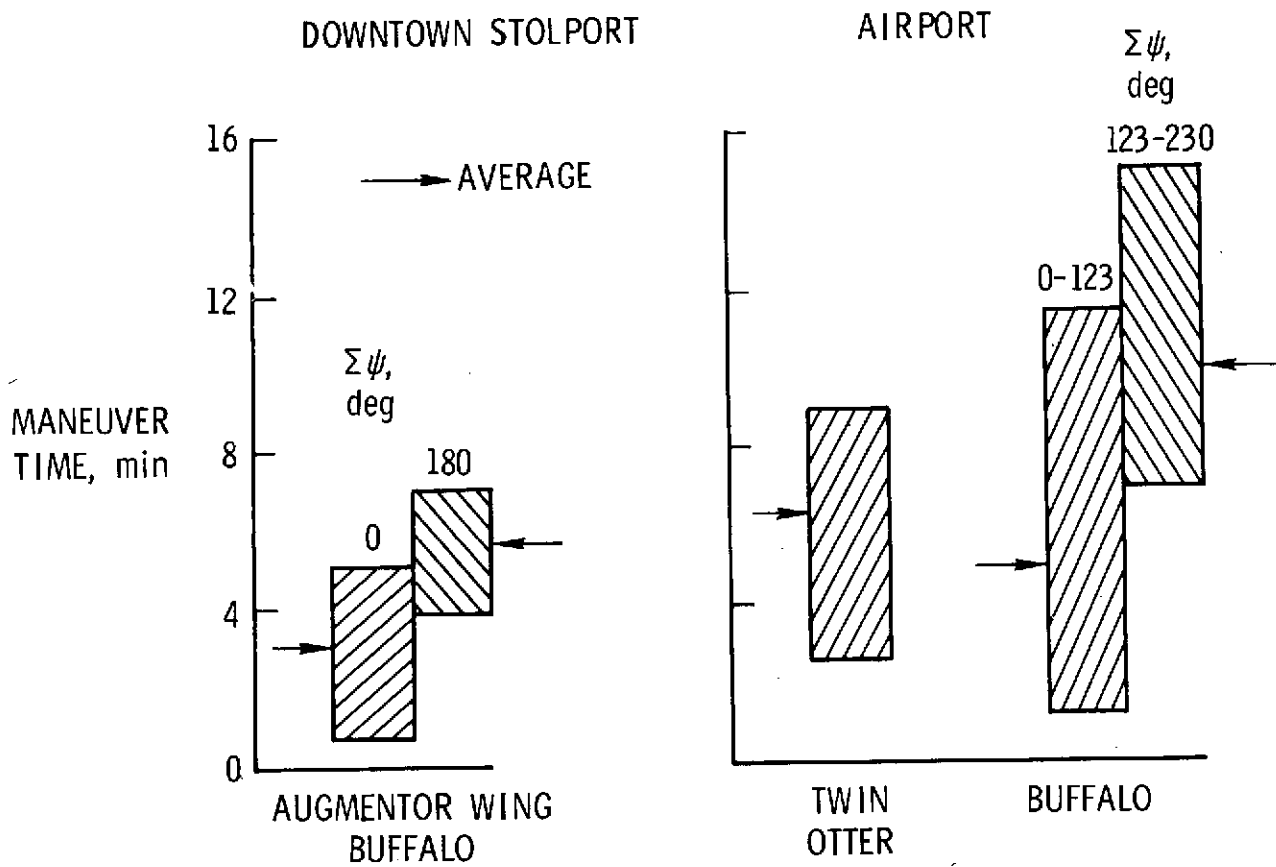

(b) Arrivals.

Figure 14.- Concluded.