

J. W. BRYAN

NASA CR-139136

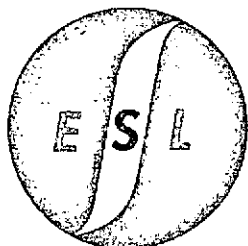

(NASA-CR-139136) THE EFFECT OF RADIO FREQUENCY INTERFERENCE ON THE 136- TO 138-MHz RETURN LINK AND 400.5- TO 401.5-MHz FORWARD (ESL, Inc., Sunnyvale, Calif.) 36 p HC \$3.75	N75-10282
CSSL 17B	Unclas G3/32 52661

THE EFFECT OF RADIO FREQUENCY INTERFERENCE ON
THE 136- TO 138-MHz RETURN LINK AND 400.5- TO
401.5-MHz FORWARD LINK OF THE TRACKING
AND DATA RELAY SATELLITE SYSTEM

Dr. J. Jenny

J. D. Lyttle

1 March 1973

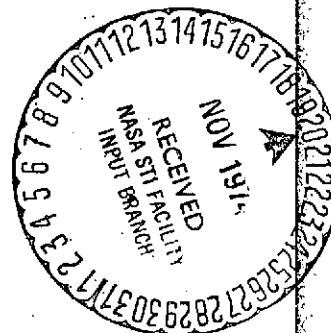

ESL INCORPORATED

ELECTROMAGNETIC SYSTEMS LABORATORIES
495 JAVA DRIVE • SUNNYVALE • CALIFORNIA

ESL-TM362
Copy No. /

ESL INCORPORATED
Electromagnetic Systems Laboratories
Sunnyvale, California

Technical Memorandum

No. ESL-TM362

1 March 1973

THE EFFECT OF RADIO FREQUENCY INTERFERENCE ON THE 136- TO 138-MHz
RETURN LINK AND 400.5- TO 401.5-MHz FORWARD LINK OF THE
TRACKING AND DATA RELAY SATELLITE SYSTEM

Dr. J. Jenny
J. D. Lyttle

Interim Report No. 1
Prepared Under
Contract NAS5-20406

This Document Consists of 34 Pages

Copy No. / of 25 Copies

TABLE OF CONTENTS

Section		Page
1.	INTRODUCTION.	1-1
1.1	Background.	1-1
1.2	Report Summary.	1-1
1.3	Conclusions	1-3
1.4	Recommendations	1-4
2.	BASIC MODELING APPROACH	2-1
3.	136- to 138-MHz BAND.	3-1
3.1	Power Level Estimates	3-1
3.2	Contingency Plan.	3-13
4.	400.5- to 401.5-MHz BAND.	4-1

ILLUSTRATIONS

Figure		Page
1-1	TDRSS Link Geometry.	1-2
2-1	Model Link Calculations.	2-2
3-1	Modeled TDRS Antenna Pattern for User Satellite Telemetry Reception.	3-2
3-2	TDRS Horizon Coverage at 41°W and 171°W.	3-3
3-3	ITU Reported Applications Between 136 and 137 MHz.	3-4
3-4	ITU Reported Applications From 137.0 to 137.999 MHz.	3-5
3-5	Measurement Threshold Calculations	3-8
3-6	Threshold for Ground Van Data.	3-9
3-7	LDR Return Link Performance.	3-12
3-8	Adaptive Digital Filter.	3-14
3-9	Transversal Realization of the Digital Filter.	3-15
3-10	Matched Filter Process	3-17
3-11	ADF Equipment.	3-18
4-1	ITU Reported Applications Between 400.5 and 401.5 MHz.	4-2
4-2	Threshold Calculations for 400-MHz Band.	4-3
4-3	Summary of 400.5- to 401.5-MHz East Coast Ground Van Measurements	4-4
4-4	LDR Forward Link Performance	4-6
4-5	Block Diagram of the FM Canceller.	4-7

TABLES

Table		
3-1	Preliminary Estimates of RFI Power Level in 1 MHz at the TDRS in the 136- to 138-MHz Band.	3-7
3-2	136- to 138-MHz Ground and Aircraft Data Summary.	3-10

THE EFFECT OF RADIO FREQUENCY INTERFERENCE ON THE 136- TO 138-MHz
RETURN LINK AND 400.5- TO 401.5-MHz FORWARD LINK OF THE
TRACKING AND DATA RELAY SATELLITE SYSTEM

1. INTRODUCTION.

1.1 Background.

ESL has been studying the effects of radio frequency interference (RFI) on the Tracking and Data Relay Satellite System (TDRSS) since 1969. This work was performed under Contract NAS5-20125 and NAS5-20228 and was limited to the 108- to 170-MHz VHF band. The purpose of this report is to update the RFI estimates in the 136- to 138-MHz VHF band and to make estimates for the first time for the 400.5- to 401.5-MHz UHF band. In December 1972, these two bands were identified to be of high interest by the TDRS office. Because of the short time available for producing these preliminary predictions (about one month) they are based on primarily ITU frequency-registration data, with missing data bridged by engineering judgement.

1.2 Report Summary.

This report assesses the impact of RFI on the TDRSS links shown on Figure 1-1.

Section 2 of this report describes the basic RFI modeling approach used in this study. Section 3 describes some of the RFI in the 136- to 138-MHz band, assesses the impact on the TDRS

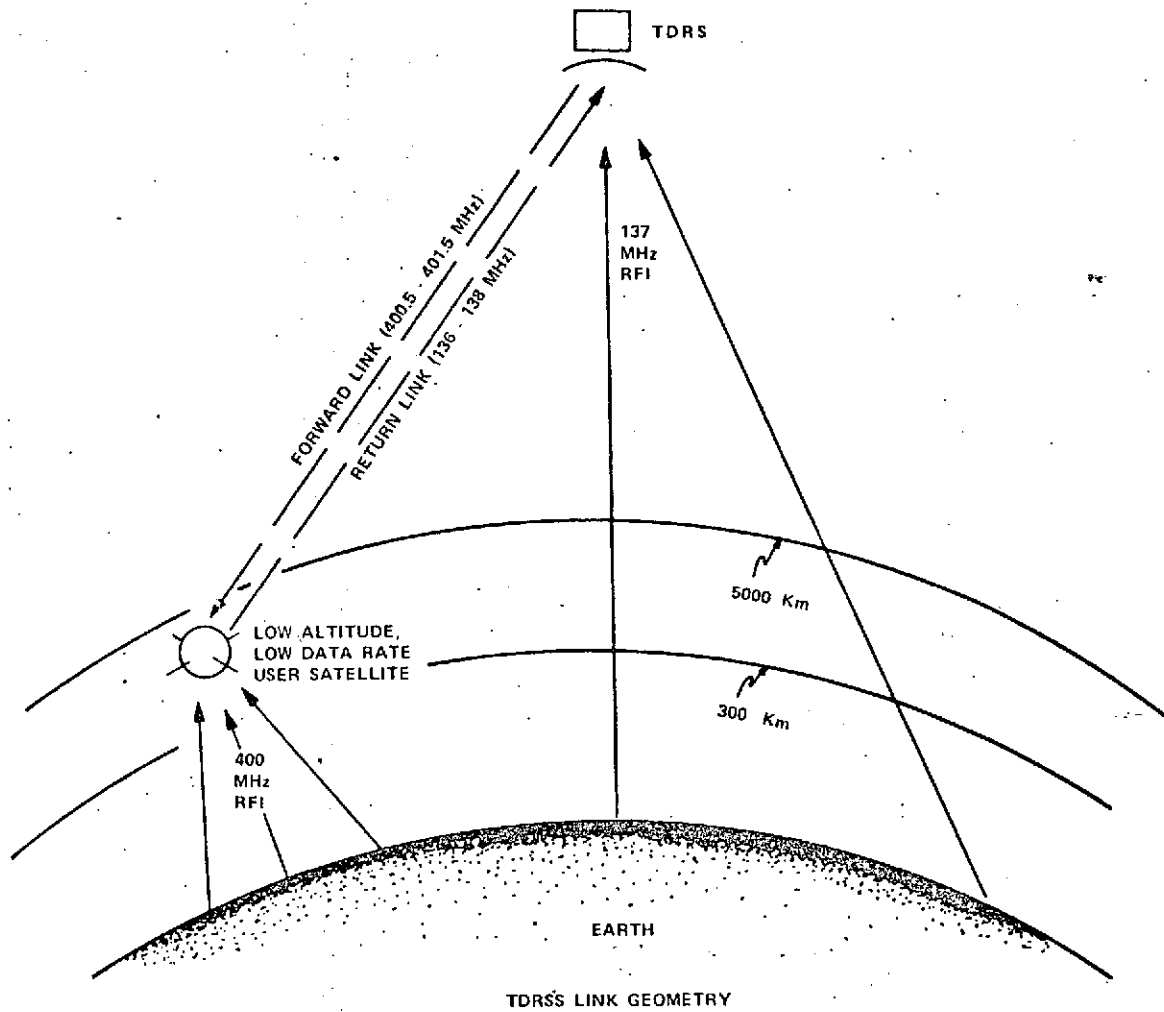

Figure 1-1. TDRSS Link Geometry

1.2 -- Continued.

low-data-rate user return link and suggests the use of digital filtering as an interference-reduction aid. Similarly, Section 4 describes 400.5- to 401.5-MHz RFI, assesses its impact on the forward link and suggests contingency plans. RFI measurements by van and aircraft in the US are introduced and evaluated where appropriate in Sections 3 and 4.

1.3 Conclusions.

The following conclusions were reached in this preliminary study:

- The return link should be limited to the 136- to 137-MHz band as this band has significantly lower RFI than the total 136- to 138-MHz band.
- Even when restricting operation to the 136- to 137-MHz band the return link data rate lies between 2 and 10 kpbs depending on what AGIPA gain is actually achieved.
- To provide a performance margin for model inaccuracies and future RFI growth, interference reduction units (such as the Adaptive Digital Filter) should be incorporated in the TDRS ground station.

1.3 -- Continued.

- The 400.5- to 401.5-MHz band is relatively free of interference over much of the world.
- The significant RFI areas that do exist could be handled by restricting command transmissions to low RFI areas and/or by including automatic notch filters in the user satellite command receivers.

1.4 Recommendations.

The following recommendations are made based on this preliminary study:

- The RFI in selected parts of S-band should be evaluated to see if this is a viable alternative to the VHF-UHF bands.
- Satellite RFI experiments should be conducted to validate the results of the model. Measurements in the U.S. alone are not conclusive and it seems unlikely that foreign governments would permit such measurements to be made from a ground van or aircraft.

2. BASIC MODELING APPROACH.

The basic approach used to generate the RFI prediction made in this report is to establish as complete a descriptive listing of emitter characteristics as possible and then to calculate combined effects of these emitters at the satellite receiver. The minimum data required for each emitter is the location, modulation type, bandwidth, carrier frequency, peak transmitter power, and antenna pattern. Often antenna pattern data are missing in the source documents and have to be supplied based on a judgement of how typical emitters in that specific band are equipped. The percent of time the station is actually on the air (duty factor) is seldom given, and this factor has been isolated in the predictions so that an independent judgement can be made as to its effect.

In addition to the emitter characteristics, the satellite receiver characteristics must be specified. The satellite location, frequency band, receiver band shape, and antenna parameters (such as boresight point, gain, sidelobe levels, and polarization mismatch) all affect the predictions. The emitter and satellite receiver characteristics are used to calculate the received power at the output of the spacecraft antenna due to each emitter. The basic calculations are shown in Figure 2-1. Once the calculations have been made for all the emitters within line-of-sight coupling to the satellite, the result can be displayed in several ways. In the past we have furnished NASA with plots of received power from each emitter vs. frequency, the number of emitters vs. frequency, and the total power summed in various bandwidths vs. frequency.

$$P_r = 10 \log_{10} P_T + 10 \log_{10} G_T(\beta_e) - 20 \log_{10} F_T - 20 \log_{10} D_{TS} + 10 \log G_r(\beta_s) + 22.2$$

WHERE:

- P_r = PEAK POWER AT THE OUTPUT TERMINALS OF THE RECEIVING ANTENNA (dBm)
- P_T = TRANSMITTER POWER (kW)
- $G_T(\beta_e)$ = TRANSMITTER ANTENNA GAIN AS A FUNCTION OF ELEVATION ANGLE TO SATELLITE
- F_T = TRANSMITTER CARRIER FREQUENCY (MHz)
- D_{TS} = SLANT RANGE TRANSMITTER - SATELLITE (NMI)
- $G_r(\beta_s)$ = RECEIVING ANTENNA GAIN AS A FUNCTION OF ELEVATION ANGLE TO TRANSMITTER

Figure 2-1. Model Link Calculations

2. -- Continued.

The RFI modeling approach described above has several limitations. These include the lack of data on the transmitter usage factors, the frequent omission of transmitter antenna type, and the lack of knowledge of location of specific mobile transmitters. An even greater limitation is the fundamentally dynamic nature of the interference. New transmitters appear periodically and old transmitters go out of service. Transmitters also change their usage patterns in daily, weekly, and even yearly cycles. It would be very expensive for any governmental or intergovernmental agency to keep track of these variations in great detail. We conclude that there will always be a fair amount of uncertainty about RFI predictions made in this manner.

3. 136- to 138-MHz BAND.

3.1 Power Level Estimates.

The 136- to 138-MHz band is used to return data collected by the user satellites to the two TDRS. Figure 3-1 shows the antenna pattern we modeled for the TDRS. It has a 3 dB beam width that covers the 1500-km user orbits and about 16 dB gain. The horizon coverages of the TDRS located at 41°W and 171°W are shown approximately in Figure 3-2.

The power level estimates presented in this report are based primarily on ITU (International Telecommunications Union) data. The data on magnetic tape received from ECAC could not be decoded in time to include in this report. The ECAC data as well as data from other available sources will be included in more methodical analyses. The emitter locations and transmitter powers listed by the ITU within the 136- to 137-MHz and 137- to 138-MHz bands are shown in Figures 3-3 and 3-4 respectively. Note that there are far fewer stations in the 136- to 137-MHz band than in the 137- to 138-MHz band.

Preliminary power estimates based on the method of Section 2 were made and are summarized in Table 3-1. The bands listed are exclusive of the end points - i.e., the 136- to 137-MHz band is really 136.001 to 136.999 MHz. This usage is based on the fact that there are many more transmitters on 1-MHz intervals and that these emitters could be avoided by appropriately shaping the receiver passband. This convention

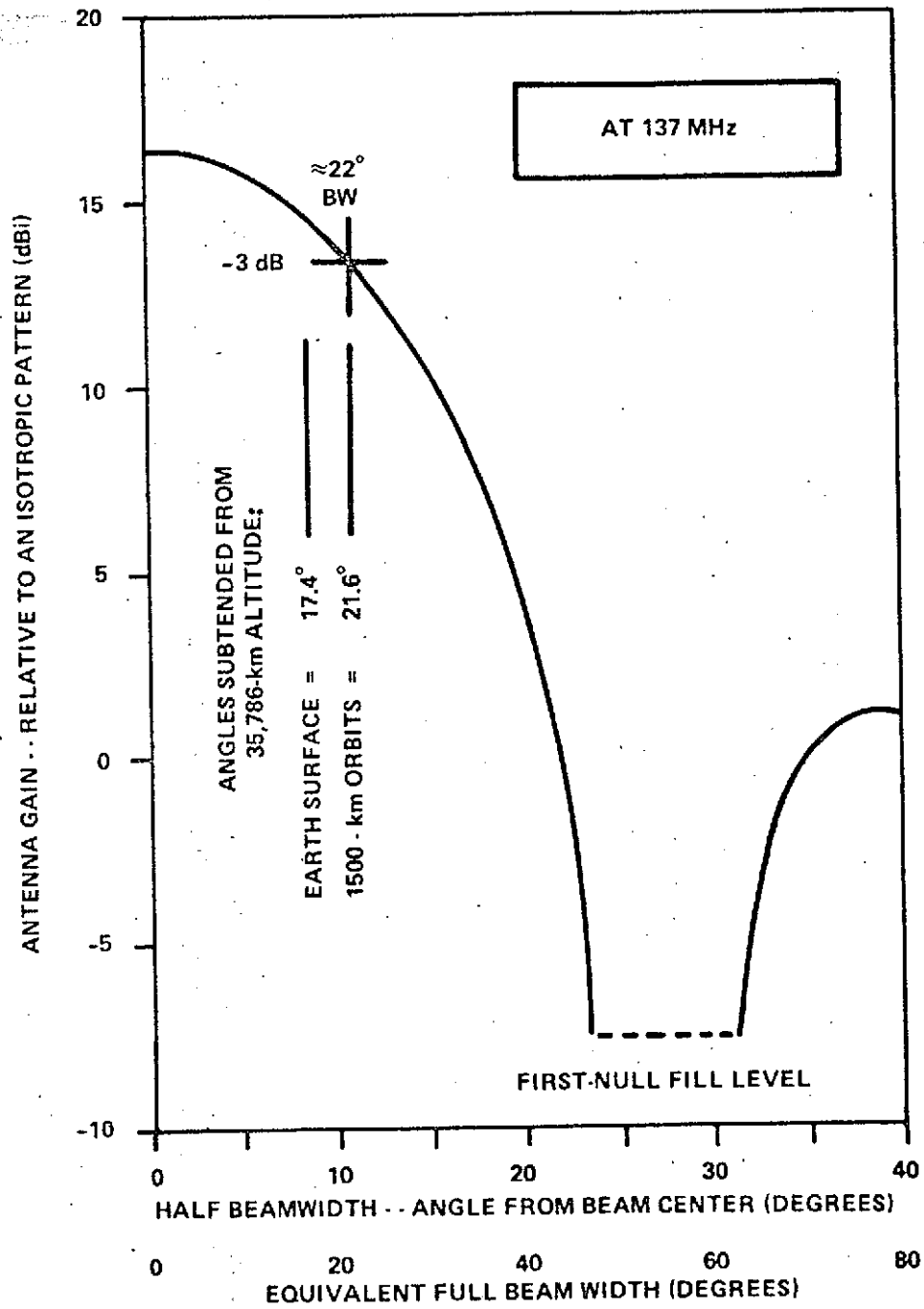

Figure 3-1. Modeled TDRS Antenna Pattern for User Satellite Telemetry Reception

REPRODUCIBILITY OF THE ORIGINAL PAGE IS POOR

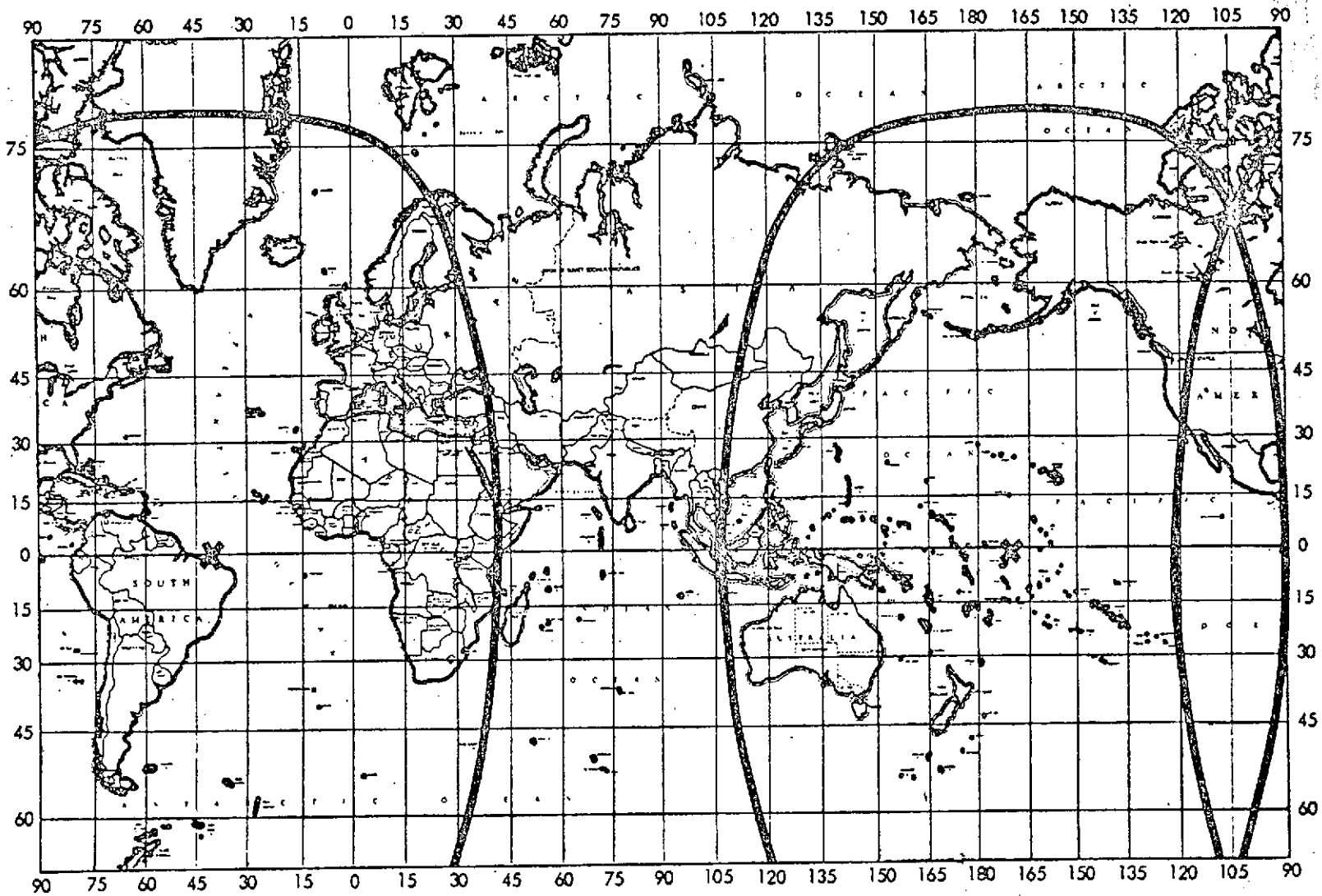
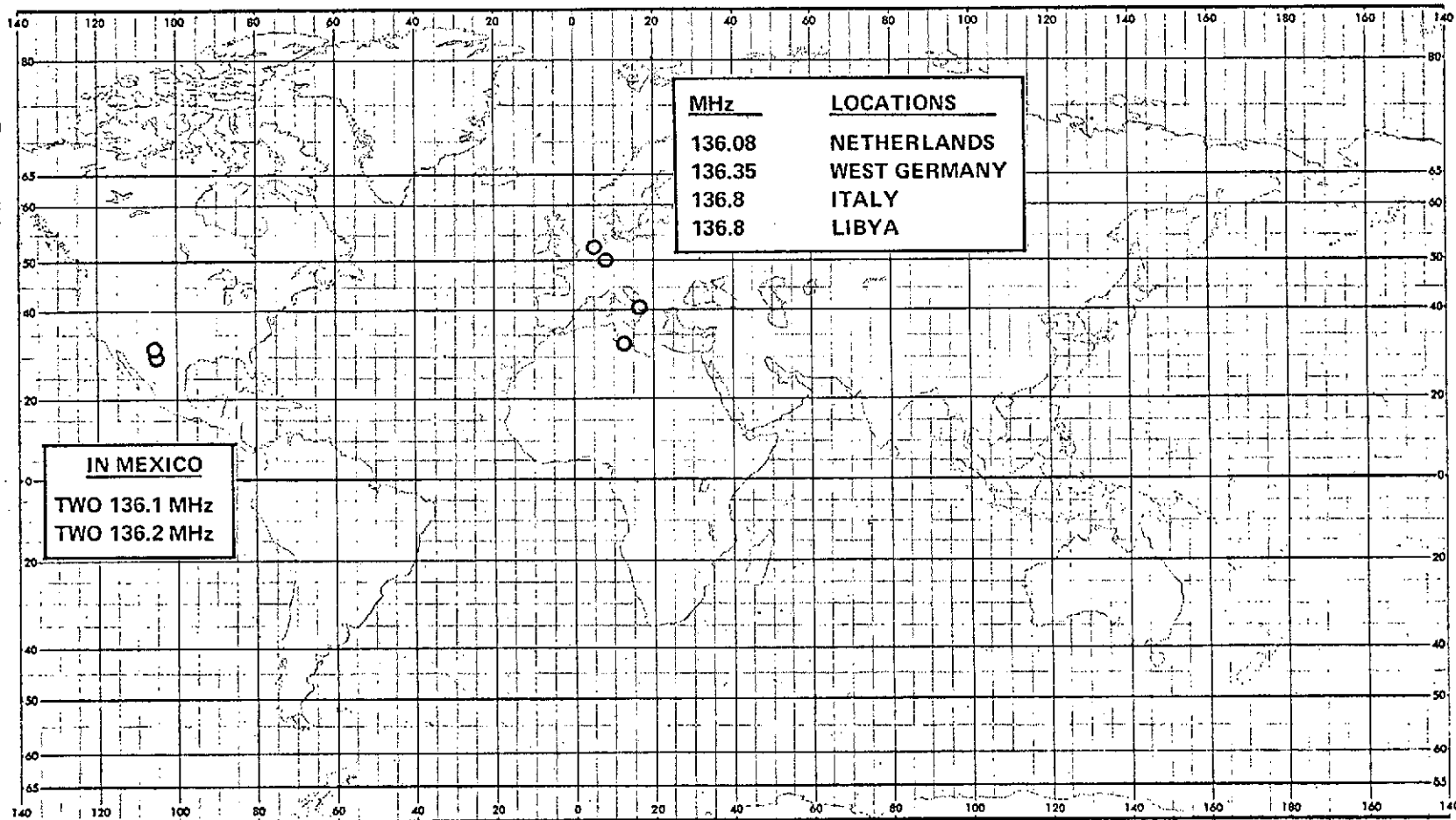

Figure 3-2. TDRS Horizon Coverage at 41°W and 171°W

ITU REPORTED APPLICATIONS BETWEEN 136 AND 137 MHz

REPRODUCIBILITY OF THE ORIGINAL PAGE IS POOR



(ALL 50-W NONDIRECTIONAL STATIONS)

Figure 3-3. ITU Reported Applications Between 136 and 137 MHz

ITU REPORTED APPLICATIONS FROM 137.0 TO 137.999 MHz

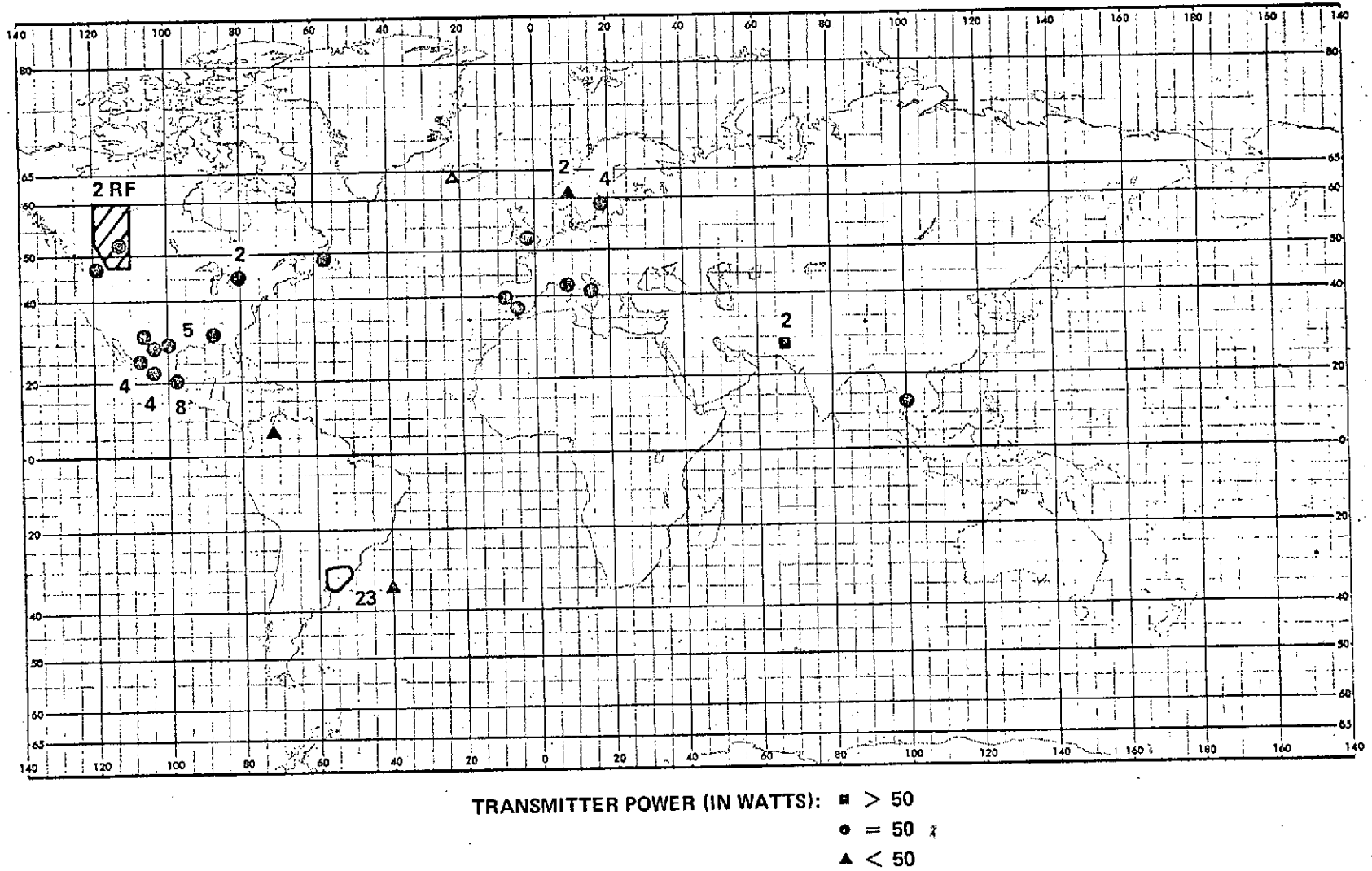

Figure 3-4. ITU Reported Applications From 137.0 to 137.999 MHz

3.1 -- Continued.

also explains why the sum of the emitters in the two 1-MHz bands does not equal the number of emitters in the 2-MHz band. (The 137.0-MHz emitters are included in the 136- to 138-MHz band but not in either of the two 1-MHz bands.)

The power levels shown in Table 3-1 assume that all the emitters are on all the time, which is certainly not the case. Aircraft and ground van measurements were made in the US in an attempt to establish the emitter duty factors. The significance of these measurements to the TDRS system can be seen in Figures 3-5 and 3-6. Figure 3-5 shows that one transmitter with an ERP of 10 watts in the direction of the TDRS or 100 transmitters at the 100-milliwatt level will produce a received power level at the output of the antenna that is just equal to the thermal noise level. Figure 3-6 shows that the total received power would have to equal -59 dBm in 2 MHz at the ground van or -79 dBm at the aircraft. This assumes a 0 dB gain receive antenna in both cases. With these threshold levels in mind, we looked at the van and aircraft power measurements. The results are summarized in Table 3-2. In 90 hours of aircraft data and 200 hours of van data the measured RFI level never equalled the thermal noise level at the TDRS. It is heartening to find such low levels of RFI in these bands. These measurements are consistent with our model, since the model did not contain any emitter in this band in the US. However, we do not believe that it is valid to take the duty factors of these very low power emitters and apply them to emitters in this band that are located in other countries.

Table 3-1. Preliminary Estimates of RFI Power Level in 1 MHz at the TDRS in the 136- to 138-MHz Band

ANT. GAIN = 16db.

TDRS LOCATION	136 TO 137 MHz		137 TO 138 MHz		136 TO 138 MHz	
	TOTAL POWER	NO. EMITTERS	TOTAL POWER	NO. EMITTERS	TOTAL POWER	NO. EMITTERS
41° W	-190 -93.7dBm	8	-183 -86.5dBm	65	-182 -85.4dBm	78
171° W	-94.6dBm	5	-89.4dBm	21	-87.7dBm	31

UNCLASSIFIED
@ 25% DF.

- NOTES: 1. THESE CALCULATIONS OMIT THE END POINT FREQUENCIES:
I. E., THE 136 - 138 MHz BAND IS REALLY 136.001 TO 137.999 MHz.
2. THEY ASSUME A 100% DUTY FACTOR.

CLASSIFIED USERS WILL ADD 6dB RFI INTERFERENCE.

FOR THE 136- TO 138-MHz BAND

NOISE FLOOR \approx -111dBm/2 MHz (INCLUDING RECEIVER NOISE)

EQUIVALENT GROUND ERP IS FOUND FROM

$$P_r = \frac{P_T G_T G_R}{4\pi R^2}$$

FOR THE SYNCHRONOUS TDRS THE

$$10 \text{ Log}_{10} P_r = -111\text{dBm}$$

$$10 \text{ Log}_{10} G_R = +16\text{dBm}$$

$$10 \text{ Log}_{10} \frac{1}{4\pi R^2} = 167\text{dBm}$$

YIELDING $10 \text{ Log}_{10} P_T G_T = +40 \text{ dBm}$. IF WE SET THE THRESHOLD SO THAT 100 EMITTERS ARE REQUIRED TO EQUAL THE NOISE FLOOR THEN

$$P_T G_T \text{ in dB} = +20 \text{ dBm} \quad \text{or } 100 \text{ MW}$$

NOTE: THIS IS CONSERVATIVE SINCE THE LINK HAS ABOUT 10 dB OF PADDING FOR INTERFERENCE.

Figure 3-5. Measurement Threshold Calculations

- ASSUME EMITTER IS 10 MILES FROM VAN (CALCULATED THRESHOLD WOULD BE HIGHER FOR CLOSER EMITTER):

- $$P_r = \frac{P_T G_T G_R}{4 \pi R^2} = -79 \text{ dBm}$$

- A SINGLE EMITTER WOULD THUS HAVE TO MEASURE -59 dBm or 100 EMITTERS WOULD EACH HAVE TO MEASURE -79 dBm TO INTERFERE WITH THE TDRS RETURN LINK.

- ASSUME EMITTER IS 100 MILES FROM AIRCRAFT.

- $$P_r = -99 \text{ dBm}$$

- A SINGLE EMITTER WOULD THUS HAVE TO MEASURE -79 dBm or 100 EMITTERS WOULD EACH HAVE TO MEASURE -99 dBm TO INTERFERE WITH THE RETURN LINK.

Figure 3-6. Threshold for Ground Van Data

Table 3-2. 136- to 138-MHz Ground and Aircraft Data Summary

<u>DATA TYPE</u>	<u>SOURCE</u>	<u>LOCATION</u>	<u>DATA LENGTH (HOURS)</u>	<u>RESULTS</u>	<u>REFERENCE</u>
AIRCRAFT	NORTH AMERICAN ROCKWELL	SAN FRANCISCO LOS ANGELES SAN DIEGO	60	-85 dBm WAS NEVER EXCEEDED. 21 SLOTS EXCEEDED -100 dBm WITH DUTY FACTORS OF 2% OR LESS.	VIC SIMAS GSFC
AIRCRAFT	NASA	EAST COAST	30	-.99 dBm THRESHOLD NEVER EXCEEDED.	NAS 5 - 10800 VIC SIMAS - GSFC
GROUND VAN	BENDIX	EAST COAST	186	-.79 dBm THRESHOLD WAS NEVER EXCEEDED.	PAT MITCHELL - GSFC
GROUND VAN	BENDIX ESL	EAST COAST	14	-.79 dBm THRESHOLD WAS NEVER EXCEEDED.	PAT MITCHELL - GSFC JON JENNY - ESL

CONCLUSION: NO SINGLE EMITTER OR COMBINATION OF EMITTERS HAS BEEN FOUND THAT EQUALS THE RECEIVER NOISE LEVEL AT THE TDRS IN THE 136- TO 138-MHz BAND.

REPRODUCIBILITY OF THE
ORIGINAL PAGE IS POOR

3.1 -- Continued.

What duty factor we should use is problematical. The only thing we can do in the short term is to use duty factors that are known for the US for similar services to those that occupy the 136- to 138-MHz band in other countries. This leads us to expect duty factors in the 10- to 25-percent range, and allows us to reduce the power estimates given in Table 3-1 by 6 to 10 dB. We will use 6 dB to be conservative until more direct data on the duty factors of foreign emitters can be obtained.

The impact of the expected level of RFI on the TDRS low-data-rate return link is shown in Figure 3-7. The interference power density for the 136- to 138-MHz band is -154 dBm/Hz, whereas the density for the 136- to 137-MHz band is -160 dBm/Hz. The interference density is thus 6 dB less in the 136- to 137-MHz band than it is in the whole 136- to 138-MHz band. This leads us to conclude that the TDRS should operate only in the 136- to 137-MHz portion of the band.

Figure 3-7 indicates clearly the importance of the AGIPA system. Without this system the performance would clearly be unacceptable. To be realistic there are two modifications that should be made to Figure 3-7. The first is that this figure does not include a link margin and NASA would never build a system without at least a 3 dB margin. The other is that there are other emitters that are known to us to be operating in this band but do not appear in the ITU listings. We feel that these emitters

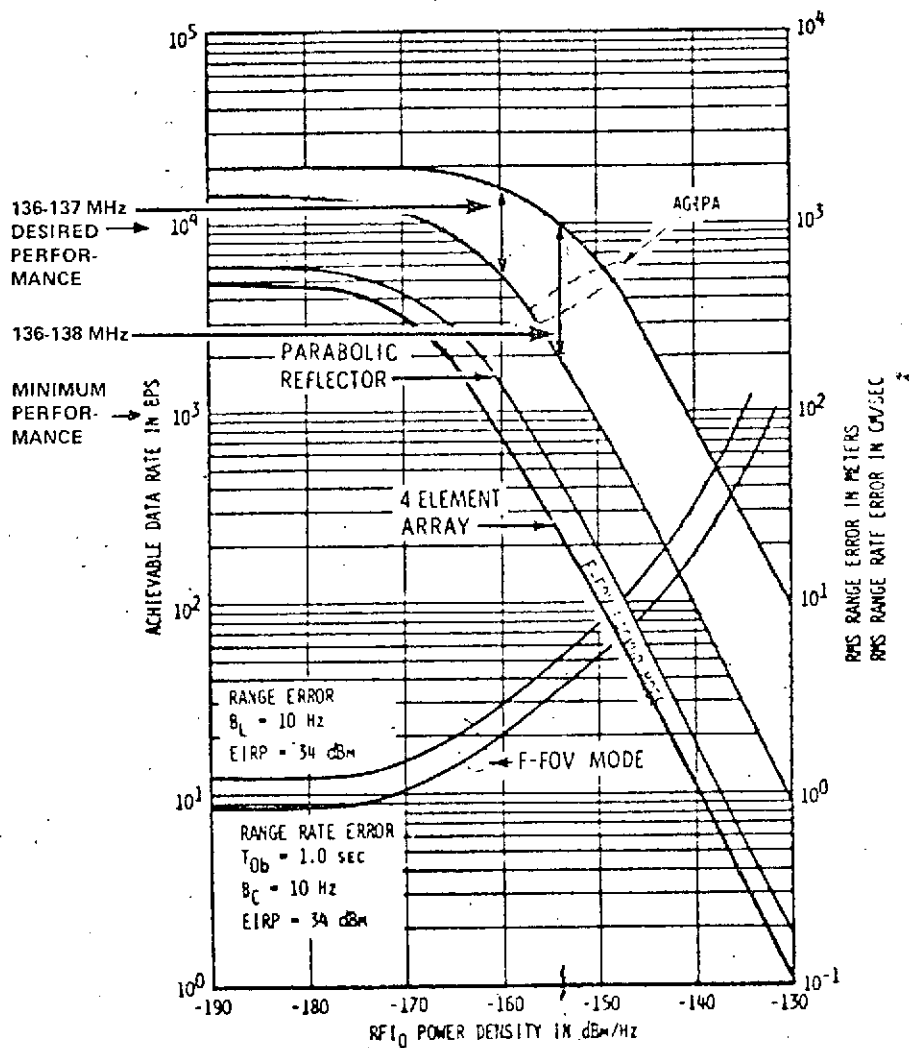

FOR 136-138 MHz: $RFI_0 = -88\text{dBm/MHz} - 60\text{dB(MHz/Hz)} - 6\text{dB(DUTY FACTOR)}$
 $= -154\text{dBm/Hz} - 170 - 117$
 $= -160\text{dBm/Hz}$

FOR 136-137 MHz: $RFI_0 = -94\text{dBm/MHz} - 60\text{dB} - 6\text{dB}$
 $= -160\text{dBm/Hz}$

Figure 3-7. LDR Return Link Performance

3.1 -- Continued.

will raise the interference levels by at least 3 dB. The additional 6 dB from these two factors raises the interference density for the 136- to 137-MHz band to -154 dBm/Hz, which reduces the data rate to the 2- to 10-kbps range, depending on the AGIPA gain.

3.2 Contingency Plan.

If the performance quoted in the previous section is not acceptable, an adaptive digital filter can be used to remove the narrowband interferers from the wideband telemetry signal. This filter can be located at the TDRS ground station where the size, weight and power requirements are much less restrictive than in the spacecraft. Figure 3-8 shows the general configuration of the adaptive digital filter. This filter can take a 2-MHz bandwidth analog input and sample it at 5-megasamples per second. Each sample contains eight bits of amplitude information. The digital data stream is filtered by a transversal digital filter. The controlling computer samples the interference and computes a new set of filter coefficients according to one of several algorithms specified from the front panel. The filter coefficients are updated every second in existing hardware. The transversal filter is shown in Figure 3-9. The existing hardware has 64 taps on the delay line with provision for the easy addition of 64 more taps. The number of taps controls the resolution of the notches that may be synthesized.

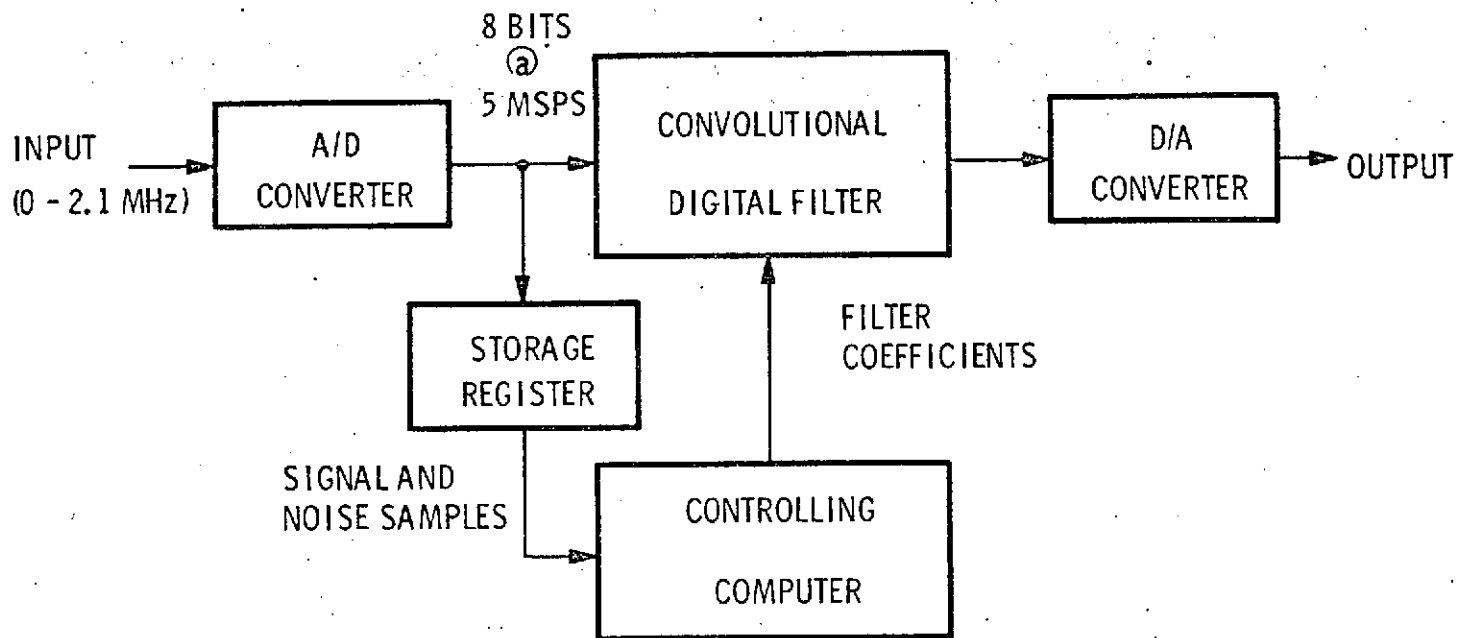
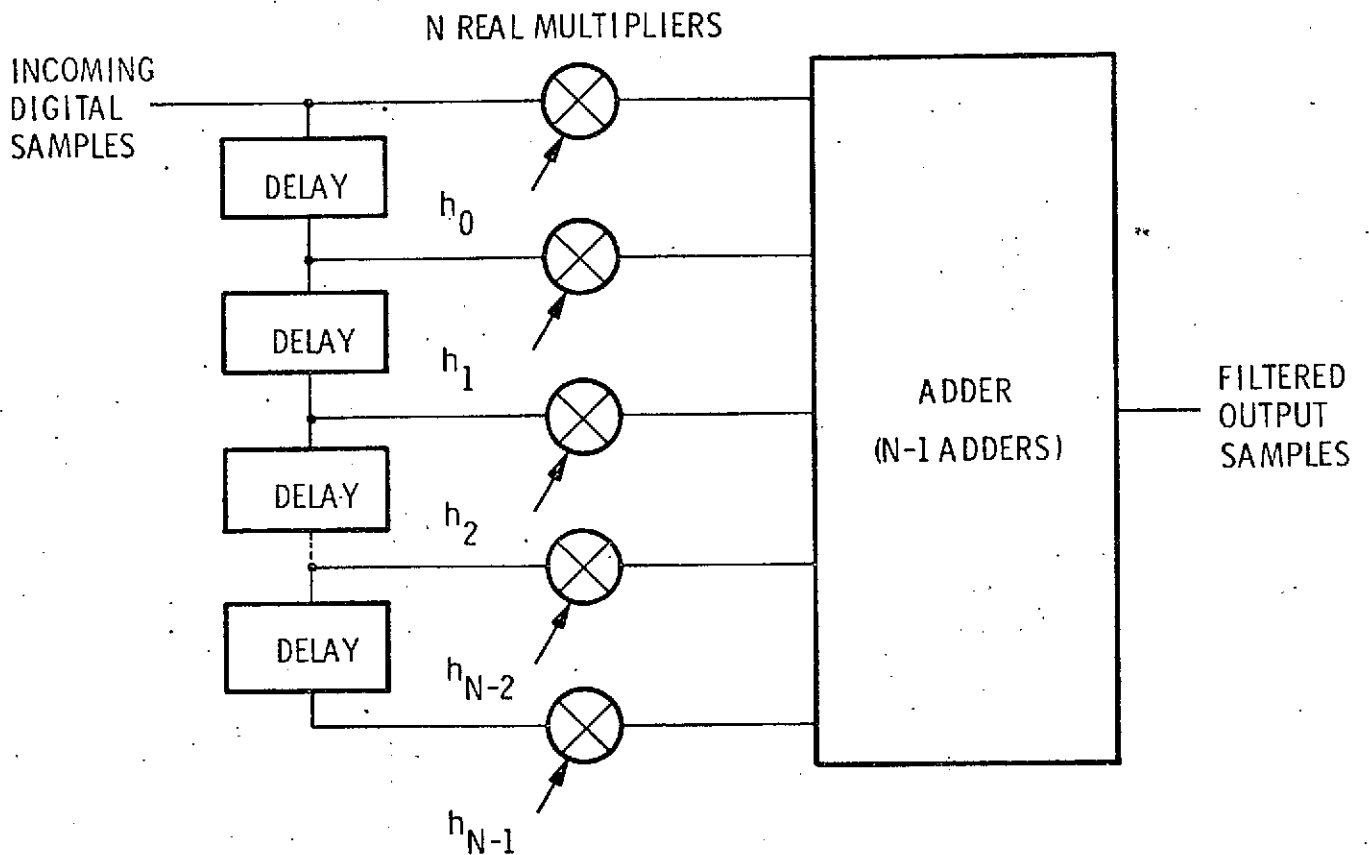

Figure 3-8. Adaptive Digital Filter



THE h_j ARE THE COMPONENTS OF THE IMPULSE RESPONSE FOR THE FILTER.

Figure 3-9. Transversal Realization of the Digital Filter

3.2 -- Continued.

Figure 3-10 illustrates the matched filtering process. Basically it matches the spectral shape of the desired signal while notching out the relatively narrowband interference. Figure 3-11 is a picture of the latest version of the ADF. The performance of the ADF is proportional to the interference level it is working against. Past experience indicates that reduction of interference levels on the order of 3 to 6 dB is achievable in moderate interference environments, while improvements of 10 to 15 dB are achievable in heavy environments.

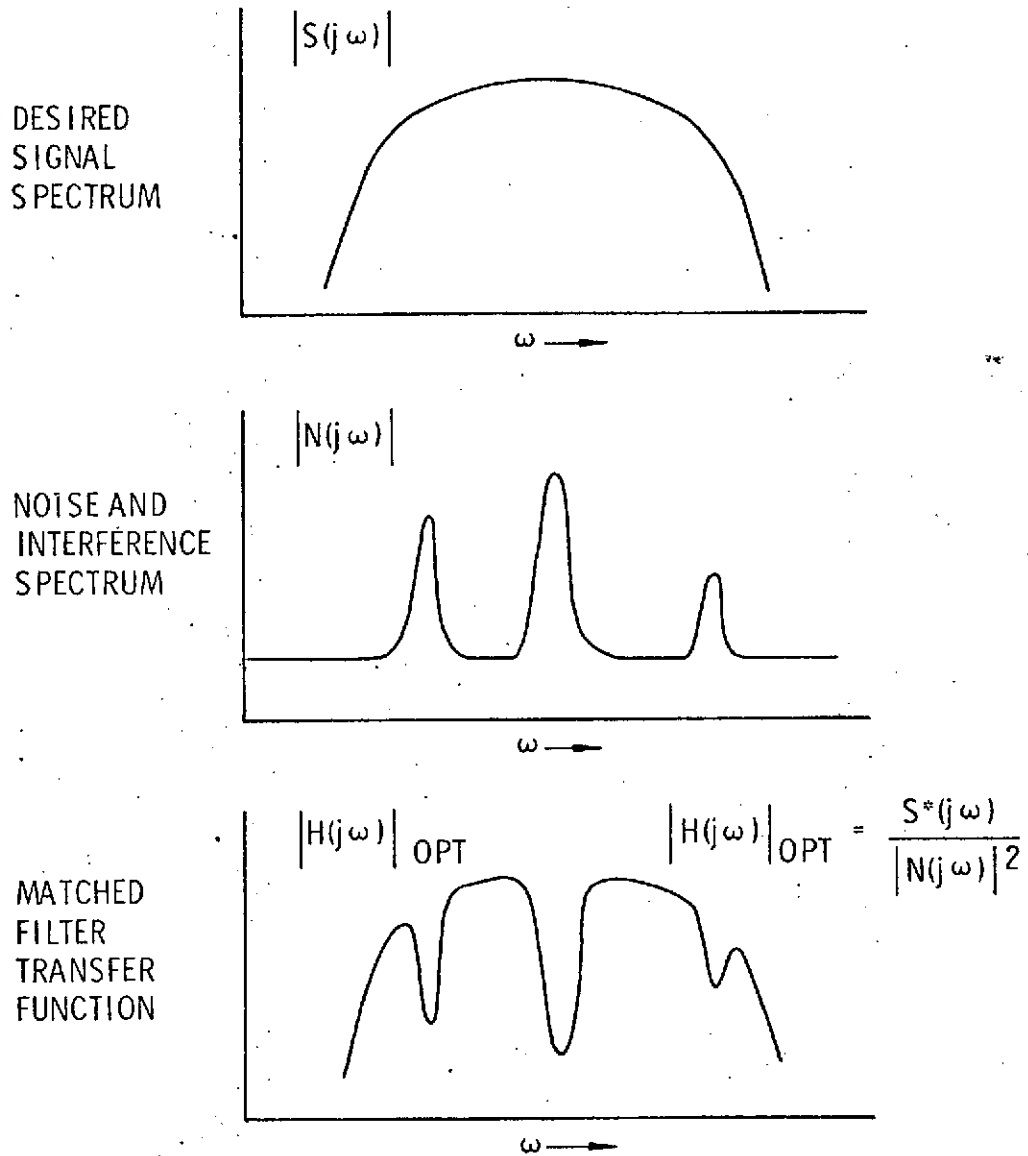

Figure 3-10. Matched Filter Process

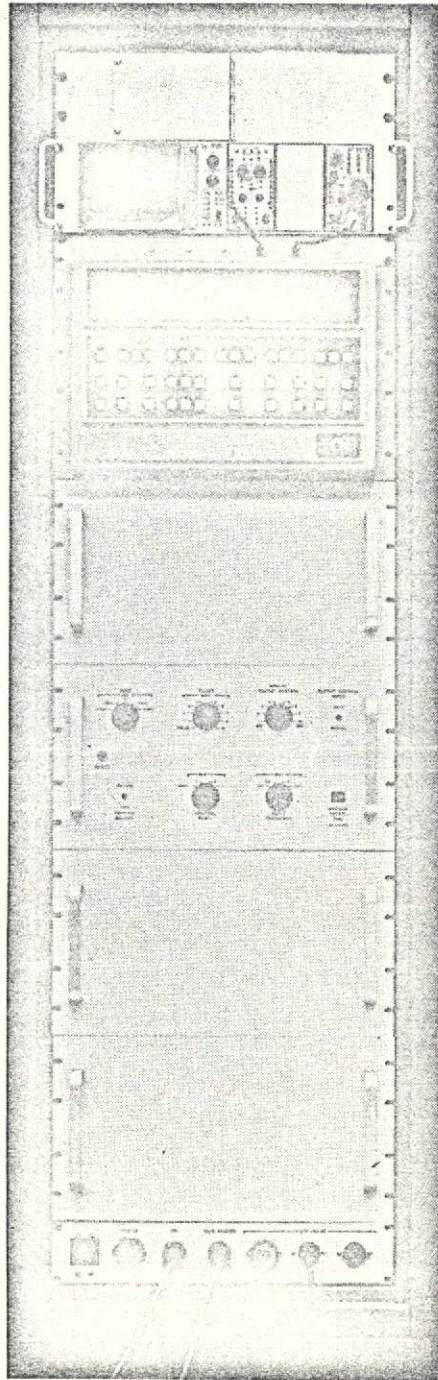

Figure 3-11. ADF Equipment

REPRODUCIBILITY OF THE
ORIGINAL PAGE IS POOR

4. 400.5- to 401.5-MHz BAND.

The 400.5- to 501.5-MHz band is used to send commands from the TDRS to the user satellites. The user satellites have an omnidirectional antenna, and since they are much closer to the earth than to the TDRS the interferers on the earth's surface have a space loss advantage over the TDRS. These two factors make the command link particularly prone to interference problems.

The ITU data for this band is shown in Figure 4-1. The band is clear over most of the world but is registered for multiple users in Greece, South Africa and Australian Sea Areas. The worst-case RFI, because more RF allocations, were judged to be in the vicinity of Australia. Obviously, we need more accurate data on the usage of this band by these areas and in the Communist world before a reliable power estimate can be made.

Van measurements of the RFI in this band were made in the Eastern United States. Thresholds were calculated as described in Section 3 and the results are shown in Figure 4-2. A summary of the data is given in Figure 4-3. In the worst case the RFI equalled the thermal noise level for 5 percent of one hour. We conclude that the RFI measured in the US would not bother the user satellite at the present time but should be monitored for future growth.

ITU REPORTED APPLICATIONS BETWEEN 400.5 AND 401.5 MHz

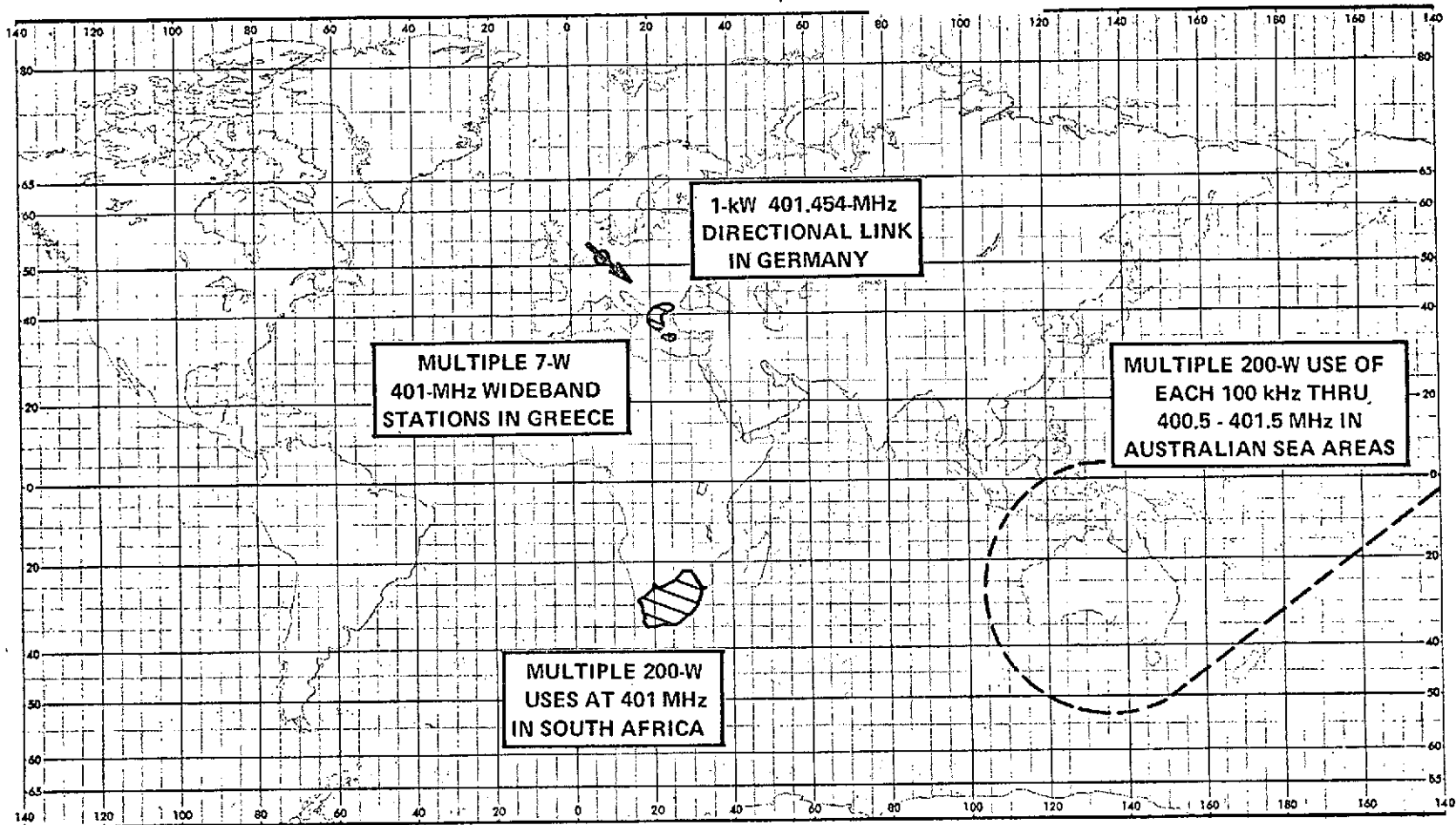

Figure 4-1. ITU Reported Applications Between 400.5 and 401.5 MHz

NOISE FLOOR \approx -114 dBm/MHz

FOR THE USER SATELLITE AT 300 km

$$10 \text{ Log}_{10} P_r = -114 \text{ dBm}$$

$$10 \text{ Log}_{10} G_R = -3 \text{ dB}$$

$$10 \text{ Log}_{10} \frac{1}{4 \pi R^2} = -134 \text{ dB}$$

YIELDING $10 \text{ Log}_{10} P_T G_T = +23 \text{ dBm}$ FOR 1 EMITTER OR +3 dBm EACH
FOR 100 EMITTERS.

GROUND VAN

1. ASSUME EMITTER AT 10 MILES
2. $P_r = -106 \text{ dBm}$
3. THERMAL NOISE LEVEL IS EQUALED BY 100 EMITTERS AT -106dBm OR
1 EMITTER AT -86dBm

AIR CRAFT

1. ASSUME EMITTER AT 100 MILES
2. $P_r = -126 \text{ dBm}$
3. THERMAL NOISE LEVEL IS EQUALED BY 100 EMITTERS AT -126dBm OR
1 EMITTER AT -106dBm

Figure 4-2. Threshold Calculations for 400-MHz Band

<u>SOURCE</u>	<u>DATA LENGTH (HRS)</u>	<u>RESULTS</u>	<u>REFERENCE</u>
BENDIX	186	IN THE WORST CASE THE -86dBm THRESHOLD WAS EQUALLED FOR ABOUT 5% OF ONE HOUR	PAT MITCHELL .. GSFC
BENDIX ESL	12	THE -106 dBm THRESHOLD WAS NOT EXCEEDED IN 11 HOURS OF DATA. IN THE OTHER HOUR, THE THRESHOLD WAS EXCEEDED 17% OF THE TIME BUT THE TOTAL POWER THRESHOLD OF -86 dBm WAS NEVER EXCEEDED.	PAT MITCHELL GSFC JON JENNY ESL

Figure 4-3. Summary of 400.5- to 401.5-MHz East Coast Ground Van Measurements

4. -- Continued.

Figure 4-4 shows the impact of the RFI on the forward link performance. Over much of the world there would be little impact, but in one of the heavy RFI areas, the data rate would be drastically reduced. This problem can be overcome by limiting command transmissions to low RFI areas or, since the number of interferers is likely to be small, they can be removed by automatic notch filters on the user satellites.

A block diagram of an automatic notch filter is shown in Figure 4-5. In this system the IF band is translated to a lower frequency band that contains a fixed notch and then translated back to the original IF. The VCO controls exactly where the notch filter sits in the IF band. During acquisition the notch is tuned to one side of the IF band and the 3-MHz filter is used to allow the control circuitry to monitor the whole band. When an interferer appears that exceeds a commanded power threshold the control circuitry tunes the VCO to notch out that particular interferer. Thus, the filter automatically notches out the highest power interferer that crosses the preset threshold. Any number of filters can be cascaded with size, weight and power being the only constraints. The size, weight and power requirements for one notch are also shown in Figure 4-5.

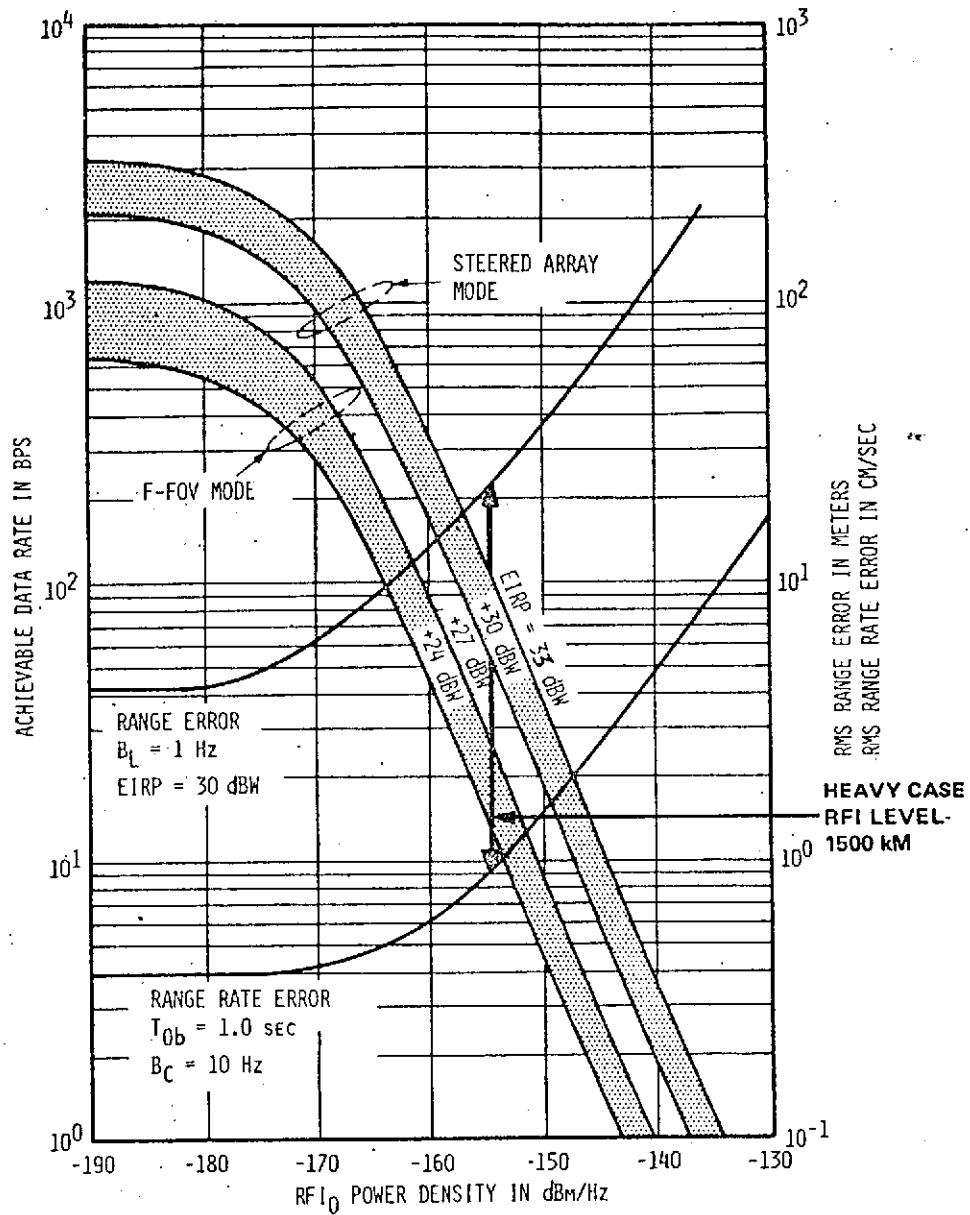

$$RFI_0 = -89\text{dBm/MHz} - 60\text{dB} - 6\text{dB} = -155\text{dBm/Hz}$$

25% DUTY FACTOR

Figure 4-4. LDR Forward Link Performance

REPRODUCIBILITY OF THE ORIGINAL PAGE IS POOR

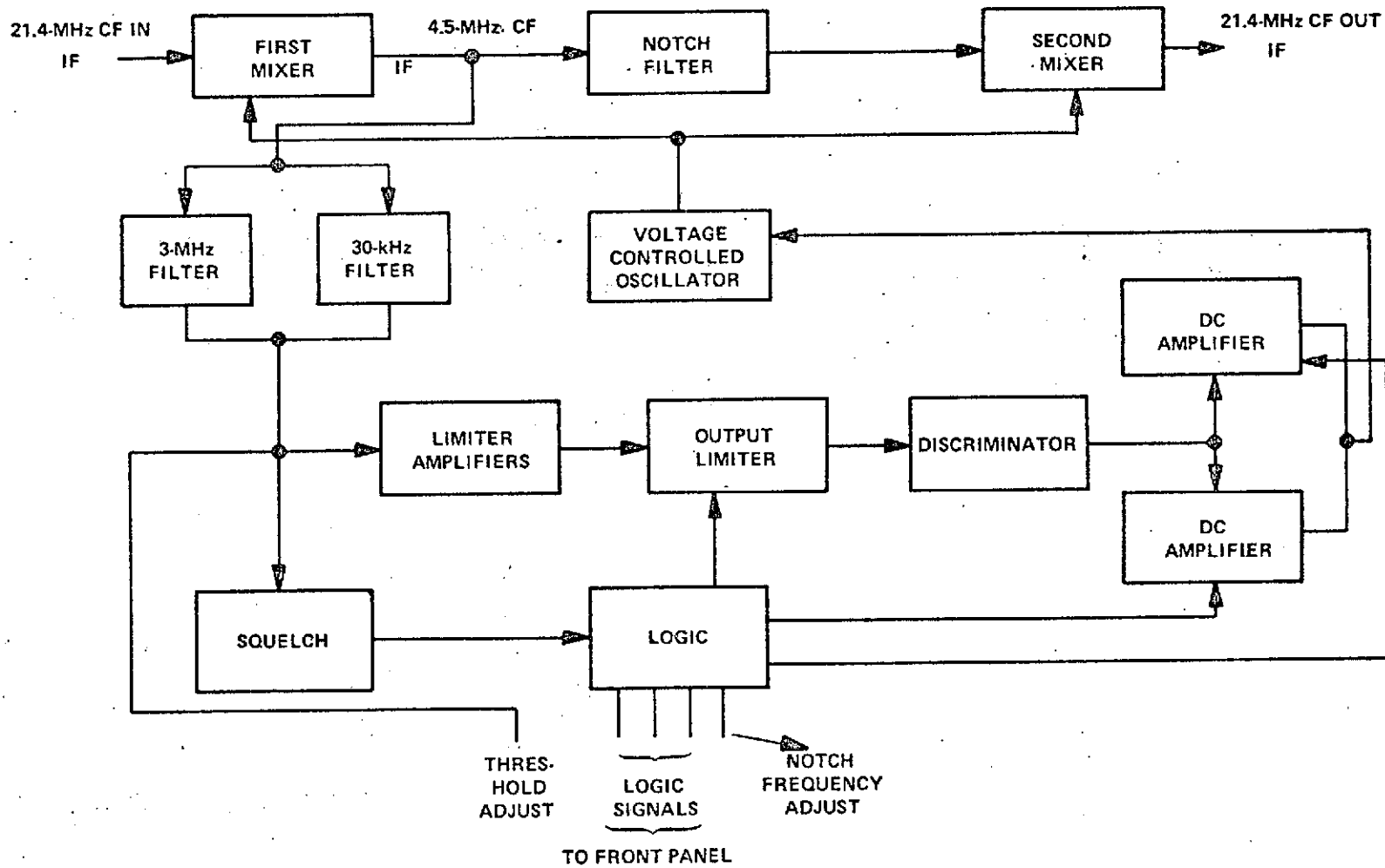

1966 TECHNOLOGY - 100 CU IN, 5 POUNDS, 1.2 WATTS
 1972 TECHNOLOGY - 25 CU IN, 1.2 POUNDS, 1.0 WATTS

Figure 4-5. Block Diagram of the FM Cancellor