

THE USE OF PRECESSION MODULATION FOR NUTATION
CONTROL IN SPIN-STABILIZED SPACECRAFT

By

Javin M. Taylor
Richard J. Donner
Vehbi Tasar

September 30, 1974

Backup Document for AIAA Synoptic Scheduled for
Publication in the Journal of Spacecraft and Rockets
February 1975

Department of Electrical Engineering
University of Missouri - Rolla
Rolla, Missouri 65401

SYNOPTIC BACKUP DOCUMENT

This document is made publicly available through the NASA scientific and technical information system as a service to readers of the corresponding "Synopsis" which is scheduled for publication in the following (checked) technical journal of the American Institute of Aeronautics and Astronautics.

- AIAA Journal
- Journal of Aircraft
- Journal of Spacecraft & Rockets, February 1975
- Journal of Hydronautics

A Synopsis is a brief journal article that presents the key results of an investigation in text, tabular, and graphical form. It is neither a long abstract nor a condensation of a full length paper, but is written by the authors with the specific purpose of presenting essential information in an easily assimilated manner. It is editorially and technically reviewed for publication just as is any manuscript submission. The author must, however, also submit a full backup paper to aid the editors and reviewers in their evaluation of the synopsis. The backup paper, which may be an original manuscript or a research report, is not required to conform to AIAA manuscript rules.

For the benefit of readers of the Synopsis who may wish to refer to this backup document; it is made available in this microfiche (or facsimile) form without editorial or makeup changes.

NOMENCLATURE

a_o	= accelerometer gain, Eq. (5)
a	= accelerometer output, Eq. (5)
I_x, I_y, I_z	= moments of inertia about principal axes
ℓ	= least common multiple of T_s, T_Ω
N	= torque, Eqs. (1), (3)
N_o	= torque, Eqs. (2), (3)
T_s	= spacecraft spin period
T_Ω	= spacecraft nutation period
α	= $-1/\tau + i\Omega$, complex energy dissipation, Eq. (14)
λ	= angular position of control thruster with respect to spacecraft axes.
$\Delta\phi$	= $\Omega \Delta t$, thrust pulse duration expressed in radians or degrees
Δt	= thrust pulse duration, in seconds
μ	= accelerometer angular position, Eq. (5)
ϕ_o	= nutation phase angle at initiation of thrust pulse
σ	= measure of moment of inertia ratio between transverse and spin axes
τ	= energy dissipation time constant
θ	= nutation angle, Eqs. (4), (6)
$\omega(t)$	= transverse angular velocity
ω_o	= initial condition on ω in Eqs. (9), (11), and (14)
ω_s	= spacecraft spin rate
Ω	= nutation frequency

**REPRODUCIBILITY OF THE
ORIGINAL PAGE IS POOR**

THE USE OF PRECESSION MODULATION FOR NUTATION
CONTROL IN SPIN-STABILIZED SPACECRAFT

Javin M. Taylor¹

University of Missouri-Rolla, Rolla, Mo.

Richard J. Donner²

McDonnell-Douglas Corp., St. Louis, Mo.

Vehbi Tasar³

University of Missouri-Rolla, Rolla, Mo.

ABSTRACT

This paper analytically derives the relations which determine the nutation effects induced in a spinning spacecraft by periodic precession thrust pulses. By utilizing the idea that nutation need only be observed just before each precession thrust pulse, a difficult continuous-time derivation is replaced by a simple discrete-time derivation using z-transforms. The analytic results obtained are used to develop two types of modulated precession control laws which use the precession maneuver to concurrently control nutation. Results are illustrated by digital simulation of an actual spacecraft configuration.

Supported by NASA Goddard Space Flight Center, Grant NGR26-003-069.

Index categories: Earth Satellite Systems, Unmanned; Spacecraft Attitude Dynamics and Control

1. Assistant Professor, Department of Electrical Engineering
2. Engineer and Master of Science candidate in Electrical Engineering at the Graduate Engineering Center, University of Missouri-Rolla
3. Master of Science candidate, Department of Computer Science

I. INTRODUCTION

Spin stabilization is used to inertially fix a spacecraft's thrust vector during a transfer ellipse; however, spin about an axis other than that of maximum inertia results in an unstable equilibrium condition. Energy dissipation resulting from fluid motion in heat pipes and fuel tanks causes the nutation angle to increase. Furthermore, during the transfer ellipse, if it is necessary to precess the spacecraft's spin axis to reorient the thrust vector, this maneuver can also cause the nutation to increase.

This paper analytically derives the relations which determine the nutation effects induced in a spinning spacecraft by periodic precession thrust pulses. By utilizing the idea that nutation need only be observed just before each precession thrust pulse, a tedious, unmanageable continuous-time derivation reduces to a simple discrete-time derivation which can be easily solved through the use of z-transforms.

The analytic results obtained are used to develop two types of modulated precession control laws which use the precession maneuver to concurrently control nutation.

Section II briefly reviews nutation in spinning spacecraft and active nutation control. Section III develops the relations which determine the nutation effects induced by periodic precession thrust pulses. Section IV develops the relations required to modulate the precession thrust pulse sequence so that nutation is reduced. Section V describes two types of modulated precession nutation control laws which are demonstrated in the digital simulation of a Synchronous Meteorological Satellite (SMS) configuration. Finally, Section VI presents conclusions.

II. NUTATION AND ACTIVE NUTATION CONTROL

In 1968 Grasshoff [1] published the original work on a control law which can be used to sense and remove nutation automatically. Grasshoff's basic differential equation for the transverse angular velocity of the spinning spacecraft is

$$\dot{\omega}(t) + i\Omega\omega(t) = N \quad (1)$$

and the solution for a control thrust duration of $(t_2 - t_1)$ seconds is given by

$$\omega(t_2) = \omega(t_1) e^{-i\Omega(t_2 - t_1)} + \frac{N_0 e^{i\lambda}}{i\Omega} [1 - e^{-i\Omega(t_2 - t_1)}] \quad (2)$$

where N in (1) is defined by Grasshoff as

$$N = N_0 e^{i\lambda} \quad (3)$$

and λ is the angular position of the thruster in the spacecraft's coordinate system. Thus, if a thrust pulse is initiated at the proper time and for the proper duration, $\omega(t_2)$ is less than $\omega(t_1)$, and the transverse angular velocity is reduced.

Grasshoff proceeds to define the nutation angle as

$$\theta = \omega(t) / (\omega_s - \Omega). \quad (4)$$

Nutation is sensed by an accelerometer with sensitive axis parallel to the spacecraft's spin axis and is removed by properly timing the firing of a small thruster whose thrust axis is also parallel to the spin axis.

The sensed acceleration is given by

$$a = a_0 \theta \sin (\Omega t + \mu) \quad (5)$$

in which θ is the nutation angle, μ is the phase angle that defines the position of the accelerometer with respect to the position of the thruster, and a_0 is a gain that is a function of the accelerometer's radial position and the spacecraft's spin rate.

Energy dissipation due to liquid movement in fuel tanks and heat pipes of the spinning spacecraft causes nutation to continually increase. For small perturbations, the increase in nutation angle, θ , caused by energy dissipation is generally represented [3] as

$$\theta(t) = \theta_0 e^{t/\tau}, \quad (6)$$

in which τ is the time constant of energy dissipation.

Due to the relationship in (4) between θ and $\omega(t)$, energy dissipation can be included in (1) to give

$$\dot{\omega}(t) + \left(-\frac{1}{\tau} + i\Omega\right)\omega(t) = N \quad (7)$$

Figure 1 illustrates a simple, nonoptimal, nutation control law investigated by Taylor [2] for the International Ultraviolet Explorer (IEU) spacecraft. A threshold is established which represents the amount of nutation that can be removed by a properly phased thrust pulse of duration equal to one spin period, i.e., $2\pi/\omega_s$. Nutation is sensed by the accelerometer. When the next zero-crossing of the acceleration sinusoid occurs, the thruster fires and reduces the nutation to near zero. Illustrations 1a and

1b show the nutation control for a small initial nutation, and 1c shows the series of repeated thrust pulses that are required for a large initial nutation.

The nutation control law presently planned for the IUE operates in the same manner except that the thrust pulse is of a duration equal to one-half the nutation period, i.e., π/Ω .

III. NUTATION DURING UNMODULATED PRECESSION

Precession of the spin axis of a spinning spacecraft can be effected by using the same thruster that is required for nutation control; however, in this case, precession in a uniform direction is the result of a train of thrust pulses which have a frequency equal to the spin frequency of the spacecraft. This section shows how precession affects the nutation of a spacecraft with and without energy dissipation.

Precession Without Energy Dissipation

Equation (1) describes the change in transverse angular velocity, and by virtue of (6), the change in nutation, angle without energy dissipation, as a result of the forcing function N .

Consider a precession maneuver consisting of a thrusting sequence of equally spaced thrust pulses that are Δt wide and have a period $T_s = 2\pi/\omega_s$. Thus,

$$\dot{\omega}(t) + i\Omega\omega(t) = \begin{cases} N, & n \cdot T_s \leq t < n \cdot T_s + \Delta t, \\ 0, & n \cdot T_s + \Delta t \leq t < (n+1)T_s. \end{cases} \quad n=0,1,2,\dots \quad (8)$$

The continuous solution for Eq. (8) is complicated by the essentially infinite pulse train. For example, the Laplace transform of Eq. (8) is given by

$$\omega(s) = \frac{\omega_0}{s+i\Omega} + \frac{N(1-e^{-\Delta ts})}{s(s+i\Omega)(1-e^{-T_s s})}. \quad (9)$$

Where ω_0 is the initial condition on (8). (See reference [4] for a discussion of the Laplace transforms of pulse trains.) The transient portion of Eq. (9) has poles at $s = 0$, $s = -i\Omega$, and $s = \pm i2n\pi/T_s$, $n = 1, 2, 3, \dots$

The inverse Laplace transform of Eq. (9) is extremely complex and tedious because the pole at $s = -i\Omega$ lies on the imaginary axis and cannot be separated by a contour from the poles at $\pm i2n\pi/T_s$. Thus, a continuous time-domain solution is formidable and not worth the effort because a bound on Eq. (8) will suffice.

The solution of Eq. (8) is straightforward if it is sufficient to know only the result at discrete times, for example, at the discrete point, nT_s , just prior to the next thrust pulse. Thus, Eq. (8) can be changed to the first-order, difference equation

$$\omega[nT_s] = \omega[(n-1)T_s] e^{-i\Omega T_s} + \frac{N}{i\Omega} (1-e^{i\Omega \Delta t}) e^{-i\Omega T_s}. \quad (10)$$

(See reference [5] for a discussion of difference equations and z-transform theory.)

By taking the z-transform of Eq. (10) and then taking the inverse z-transform, the discrete time solution is

$$\omega[nT_s] = \omega_0 e^{-i\Omega(nT_s)} + \frac{N}{i\Omega} (1-e^{i\Omega \Delta t}) e^{-i\Omega T_s} \left[\frac{1}{1-e^{-i\Omega T_s}} + \frac{e^{-i\Omega(nT_s)}}{1-e^{i\Omega T_s}} \right] \quad (11)$$

The dynamics of (11) are more apparent if constant parameters are combined to give

$$\omega[nT_s] = k_1 + e^{-i\sigma_1} + [\omega_0 - k_1 e^{-i(\sigma_1 + \sigma_2)}] e^{-i\Omega(nT_s)} \quad (12)$$

in which k_1 is a constant given by

$$k_1 = \frac{N \sin(1/2\Omega\Delta t)}{\Omega \sin(1/2\Omega T_s)} \quad (13)$$

and $\sigma_1 = \frac{1}{2}\Omega(T_s - \Delta t) + \pi/2$, $\sigma_2 = \Omega T_s$ are both constants.

Equation (12) is periodic with period, ℓ , where ℓ is the least common multiple of $[T_s, T_\Omega]$, and T_Ω is the nutation period $2\pi/\Omega$. In Eq. (13), k_1 is bounded except for the singularity that occurs when $T_s = \pi/\Omega$, which is the case when the spin period equals one-half the nutation period. Thus, nutation resulting from precession, in the absence of energy dissipation, is bounded except at one singularity.

Precession With Energy Dissipation

Equation (7) describes the change in transverse angular velocity, and consequently nutation, with energy dissipation. As in the case without energy dissipation, the use of the z-transform to provide a discrete-time solution offers the most straightforward approach. Thus, the discrete-time solution of Eq. (7) is

$$\omega[nT_s] = \omega_0 e^{-\alpha(nT_s)} + (N/\alpha) (1 - e^{-\alpha\Delta t}) e^{-\alpha T_s} \left[\frac{1}{1 - e^{-\alpha T_s}} + \frac{e^{-\alpha(nT_s)}}{1 - e^{\alpha T_s}} \right] \quad (14)$$

where $\alpha = -(1/\tau) + i\Omega$

Equation (14) can be simplified by the replacements $k_3 = (N/\alpha) e^{-\alpha T_s} (1 - e^{-\alpha \Delta t}) / (1 - e^{-\alpha T_s})$ and $k_4 = k_3 e^{-\alpha T_s}$ to give

$$\omega[nT_s] = (\omega_0 - k_3) e^{\frac{1}{T} (nT_s)} e^{-i\Omega(nT_s)} + k_4. \quad (15)$$

in which $\omega[nT_s]$ is unbounded unless ω_0 exactly equals k_3 , which is only theoretically possible.

The conclusions are that with no energy dissipation and with a judicious choice of inertia ratios, which determine the relationship between T_s and T_Ω , nutation resulting from unmodulated precession is bounded and periodic and can be kept at tolerable levels. With energy dissipation, nutation resulting from unmodulated precession is unbounded.

IV. NUTATION DURING MODULATED PRECESSION

Because precession and nutation control can use the same thruster, precession thrust pulses can be selected that will concurrently reduce nutation.

The effect of a single precession pulse on nutation can be demonstrated by a graphic representation of Eq. (1) shown in Figure 2a. In this figure, $\Delta\Phi = \Omega(t_2 - t_1)$ is the duration in radians of the thrust pulse during each nutation cycle. Thus, for an initial $\omega(t_1)$ at an angle Φ_0 , under the influence of a thrust pulse of $\Omega(t_2 - t_1)$ radians in duration, $\omega(t_2)$ is the resultant of the fixed thrust vector plus $\omega(t_1)$ rotated through the angle $\Delta\Phi$. For the conditions shown in Figure 2a, $\omega(t_2)$ is greater than $\omega(t_1)$, i.e., nutation has increased.

Figure 2b shows the locus of $\omega(t)$ for a thrust pulse of given

duration as a function of $\omega(t_1)$ and the initial angle ϕ_0 . Note that nutation is reduced whenever $\omega(t_2)$ occurs in the hatched area.

Figure 2c is essentially the same as Figure 2b except that circle A and circle B are scaled to show the initial angle ϕ_0 . The displacement of the scales on circle A and circle B results from the value of $\Delta\phi$. Thus, for a thrust pulse of duration $\Delta\phi=90^\circ$, starting when the tip of the $\omega(t_1)$ vector is at $\phi_0=0^\circ$ on circle B, the result will be an $\omega(t_2)$ vector with the tip at 0° on circle A. Figure 2c also shows the range of ϕ_0 for which the thrust pulse will reduce nutation, i.e., $\omega(t_2) \leq \omega(t_1)$. In this case,

$$\omega(t_2) \leq \omega(t_1) \text{ for } \begin{cases} 0^\circ \leq \phi_0 \leq 29^\circ \\ 239^\circ \leq \phi_0 \leq 360^\circ. \end{cases} \quad (16)$$

The range of ϕ_0 can be analytically derived from Eq. (2).

After trigonometric manipulation, replacement of $\omega(t_1)$ by $\omega(t_1)e^{-i\phi_0}$, and $\Omega(t_2-t_1)$ by $\Delta\phi$ gives

$$\omega(t_2) = \omega(t_1)e^{-i\phi_0}e^{-i\Delta\phi} + \frac{2N_0}{\Omega} \sin\left(\frac{\Delta\phi}{2}\right)e^{i\left(\lambda - \frac{\Delta\phi}{2}\right)}. \quad (17)$$

Equation (17) is Grasshoff's equation (4) [1], but restructured so that the bound on ϕ_0 for which $\omega(t_2) \leq \omega(t_1)$ can be determined.

The expression for the range of ϕ , for which $\omega(t_2) \leq \omega(t_1)$, is given by

$$\arccos[-m \sin(\Delta\phi/2)]_{II}^{-\lambda - (\Delta\phi/2)} \leq \phi_0 \leq \arccos[-m \sin(\Delta\phi/2)]_{III}^{-\lambda - (\Delta\phi/2)}, \quad (18)$$

in which $\arccos[\cdot]_{II}$ and $\arccos[\cdot]_{III}$ refer to angles in the II and III quadrants, respectively, and m is given by

$$m = (N_0/\Omega)(1/\omega(t_1)). \quad (19)$$

Equation (18) verifies the graphical results of Figure 2c, shown in (16), for $\Delta\phi = 90^\circ$, $\lambda = 180^\circ$, and $m = 0.375$.

Physically, m is the ratio of the radius of the thrust pulse lobe and the initial nutation.

For a given precession maneuver, all variables in (18) and (19) are fixed except for $\omega(t)$ which is linearly related to the nutation angle θ , at the beginning of a precession thrust pulse.

To summarize, Eq. (18) shows that a relation exists which can be used to modulate, or gate, the precession pulse train so that only precession pulses are allowed which concurrently reduce nutation. In fact, the nutation sensing accelerometer discussed in Section II and a threshold derived from Eq. (18) can be used to provide precession pulse gating.

Figure 3a shows the use of the accelerometer output for time-optimal nutation control. The duration of the nutation removal thrust pulse is π/Ω , which is one-half the nutation period. Furthermore, any thrust, which has a pulse duration of less than π/Ω but occurs during the negative half-cycle of the accelerometer output, will also reduce nutation, but suboptimally.

Figure 3b is a block diagram of a modulated, precession, nutation control. The end result is that only precession pulses that concurrently reduce nutation are passed to the thruster.

To substantiate that a nutation control law of the type shown in Figure 3 will control nutation over an extended period of time, it is necessary to determine the average and maximum time between modulated precession pulses. Because precession pulses are used for nutation control, the nutation removed by a precession pulse must be greater than nutation buildup between

precession pulses resulting from energy dissipation. As nutation increases, the gate width in Figure 3b increases to 180° . Thus, on the average 50 percent of the precession pulses will be passed and 50 percent will be blocked. Nutation can be controlled if the nutation increase in time $2T_s$, where T_s is the spin period, is less than the nutation removed by one precession thrust pulse.

The maximum time between gated precession thrust pulses is difficult to show analytically and depends on the ratio of T_Ω to T_s which may be irrational. Computer solution for the spacecraft described in Table 1 shows that for a gate width of 50 percent, maximum precession pulse separation is $3T_s$. Furthermore, for the spacecraft of Table 1, modulated precession pulses can maintain the nutation angle at less than 6 milliradians for precession pulse separation up to 50 to $60T_s$.

V. MODULATED PRECESSION NUTATION CONTROL

This section describes two control laws which use modulated precession pulses to control nutation. The corresponding figures show digital computer simulation results of these control laws applied to the Synchronous Meteorological Satellite (SMS) configuration specified in Table 1.

Of the two precession modulation nutation control methods described below, the first provides continuous precession modulation, and the second allows unmodulated precession until nutation increases to a threshold value at which time the precession is

modulated. Figure 4 shows the behavior for the continuous precession modulation nutation control. Because the gate width, as given in (18), varies directly with nutation, the precession increase and nutation decrease will be fairly rapid initially. As the nutation reduces, fewer precession pulses are passed, and the increase in precession with respect to time reduces to the constant rate shown.

Figure 5 shows the behavior for the nutation control law which allows unmodulated precession until nutation increases to a threshold value at which time the precession is modulated. Thus, the precession and nutation increase until the nutation threshold is reached. At this time, precession modulation occurs. The slope of the precession increase diminishes as the result of precession modulation, and the nutation is held near the threshold level.

VI. CONCLUSION

This paper analytically derives the relations which determine the nutation effects induced in a spinning spacecraft by periodic precession thrust pulses. By utilizing the idea that nutation need only be observed just before each precession thrust pulse, a tedious, unmanageable continuous time derivation reduces to a simple discrete-time derivation which can be easily solved through the use of z-transforms.

The analytic results obtained are used to develop two types of modulated precession control laws which use the precession maneuver to concurrently control nutation. In the first case the

control law passes only those precession pulses that concurrently reduce nutation. Consequently, as shown in Figure 4, 2000 seconds are required to precess 30° , but after the first ten seconds of the precession maneuver nutation remains below 2 milliradians.

In the second case the control law passes all precession pulses until nutation builds up to a threshold of 5.48 milliradians. For nutation above the threshold only nutation reducing precession pulses are passed. Precession is faster and 2100 seconds are required to process the entire 180° .

By way of contrast, a simulation of a conventional control law which allows nutation control or precession, but not concurrently, for the SMS configuration described in Table 1 requires 1990 seconds to precess 180° . The fuel budget for the modulated precession control law shown in Figure 5 is 228.9 seconds of thruster fuel. For the conventional type of precession and nutation control the fuel budget is 307.9 seconds of thruster fuel.

In conclusion, for spacecraft such as those described by Grasshoff [1], and Taylor [2], for the SMS, and others emphasizing active on-board nutation control with an accelerometer as the nutation sensing element, the mechanization of the control laws described herein is straightforward and requires little additional electronic circuitry.

REFERENCES

1. Grasshoff, L. H., "An Onboard, Closed-Loop, Nutation Control System for a Spin-Stabilized Spacecraft," Journal Spacecraft and Rockets, pp. 530-535, May 1968.
2. Taylor, J. M., "The SAS-D Nutation Control System," NASA Technical Document X-732-72-196, Goddard Space Flight Center, Greenbelt, Maryland, June 1972.
3. Alfriend, K. T., "Analysis of a Partially Filled Viscous Ring Damper," NASA Technical Document X-732-71-456, Goddard Space Flight Center, Greenbelt, Maryland, October 1971.
4. Gupta, S. C., Transform and State Variable Methods in Linear Systems, Wiley and Sons, 1966.
5. Tou, J. T., Digital & Sampled-data Control Systems, McGraw-Hill, 1959.

TABLE I

SMS SPACECRAFT CONFIGURATIONMass Properties

Mass = 42.8 Slugs

$I_x = 244.4 \text{ Slug-Feet}^2$

$I_y = 246.9 \text{ Slug-Feet}^2$

$I_z = 97.3 \text{ Slug-Feet}^2$

$\sigma = 0.6039$

Angular Velocity

$\omega_z = 90 \text{ RPM (spin axis angular velocity)}$

$\Omega = 5.6916 \text{ rad/sec (nutation frequency)}$

Thruster Properties

Thrust = 5 lbs.

Moment Arm = 3 Feet

Duty Cycle = 1/12 seconds (45° of spin period) for Precession

= 0.552 seconds (1/2 nutation period) for nutation

Energy Dissipation Time Constant

$\tau = 180 \text{ seconds.}$

FIGURE CAPTIONS

- Figure 1. (a) Nutation Control for Small Angles (Phase Plane).
(b) Nutation Control for Small Angles.
(c) Nutation Control for Large Angles.
- Figure 2. (a) Graphical Interpretation of Equation (1).
(b) Nutation Reduction Area
(c) Nutation Reduction Area Scaled to Initial Angle ϕ_0
- Figure 3. (a) Nutation Sensing Accelerometer Output
(b) Modulated Precession-Nutation Control
- Figure 4. SMS Simulation Results for Full Modulated Precession
Nutation Control
- Figure 5. SMS Simulation Results for Full Precession/Threshold
Modulated Precession Nutation Control

THRESHOLD EXCEEDED AND PROPERLY PHASED THRUST PULSE INITIATED

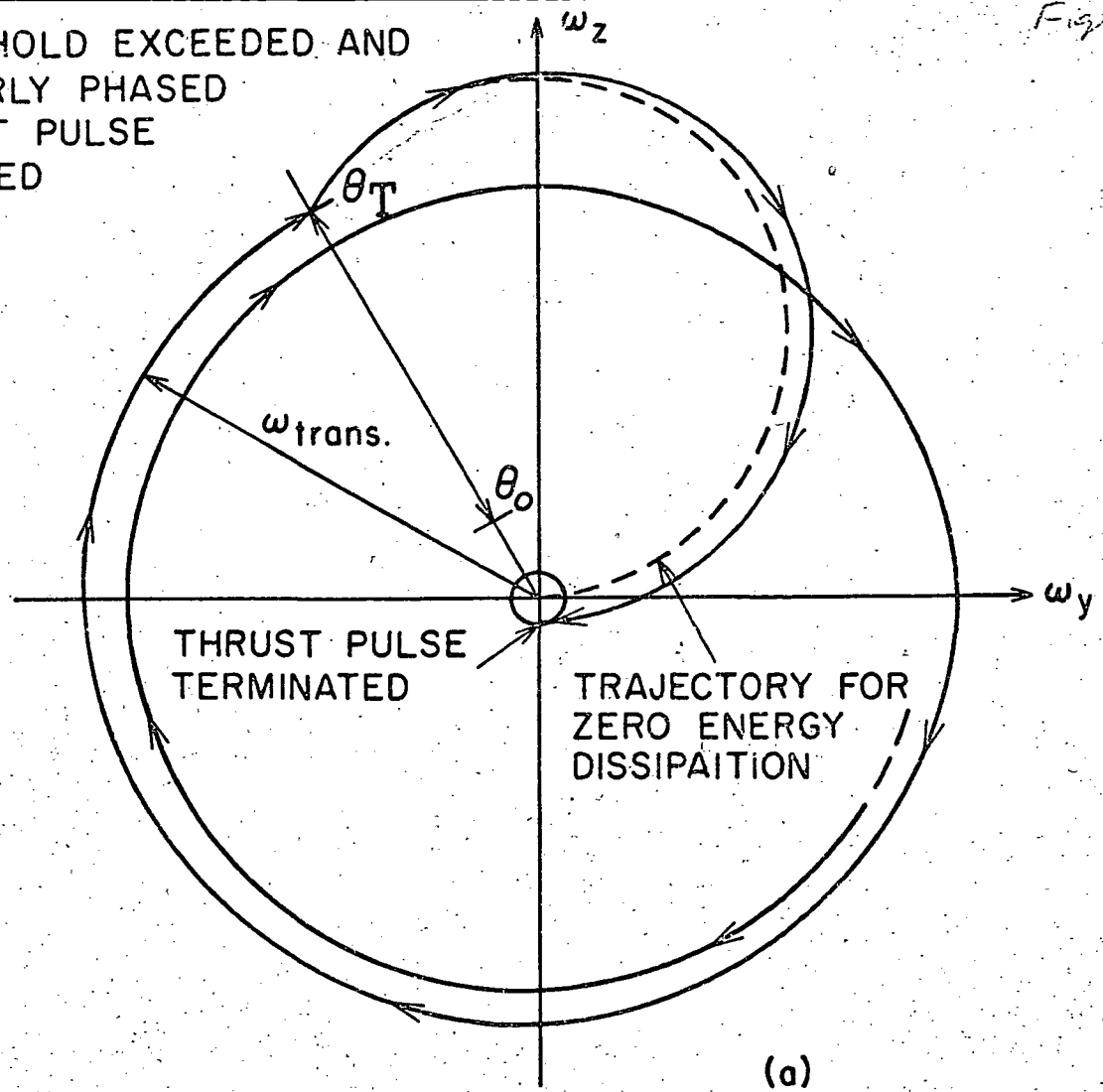

(a)

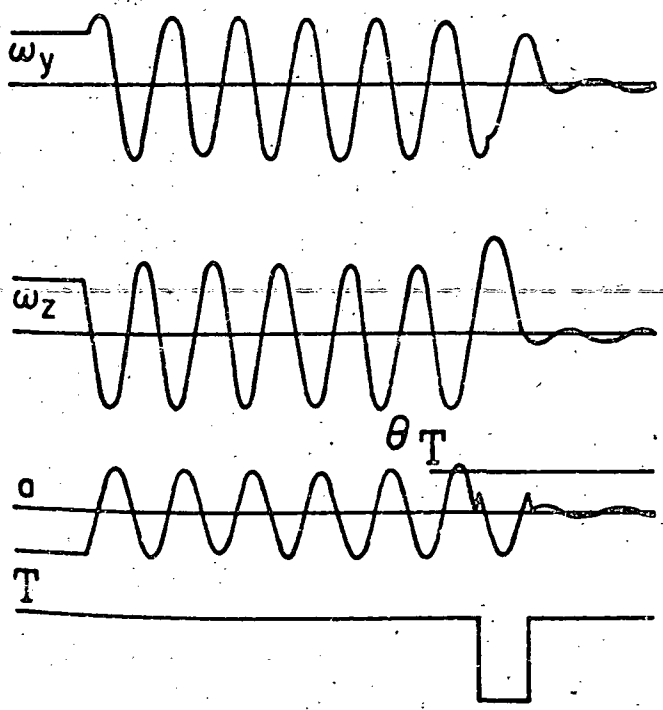

(b)

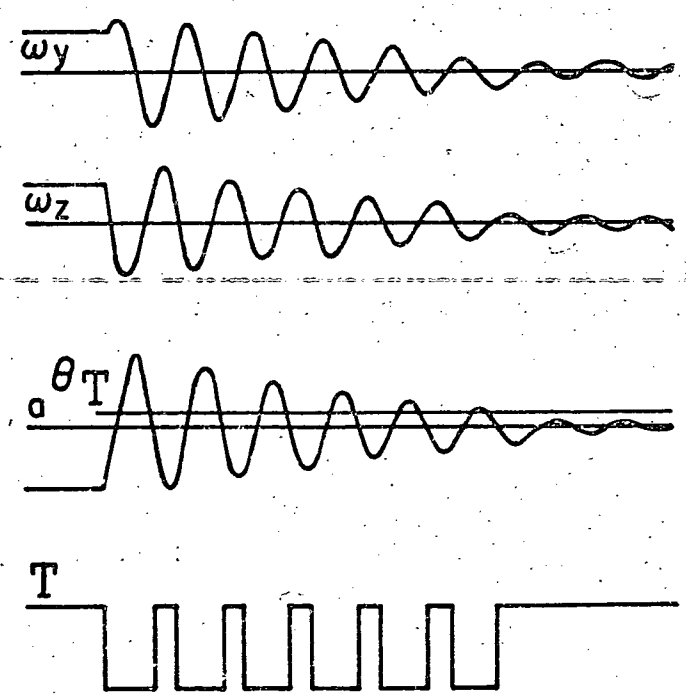

(c)

$$\frac{2N_0}{\Omega} \sin\left(\frac{\Delta\phi}{2}\right) \epsilon^{i\left(\lambda - \frac{\Delta\phi}{2}\right)}$$

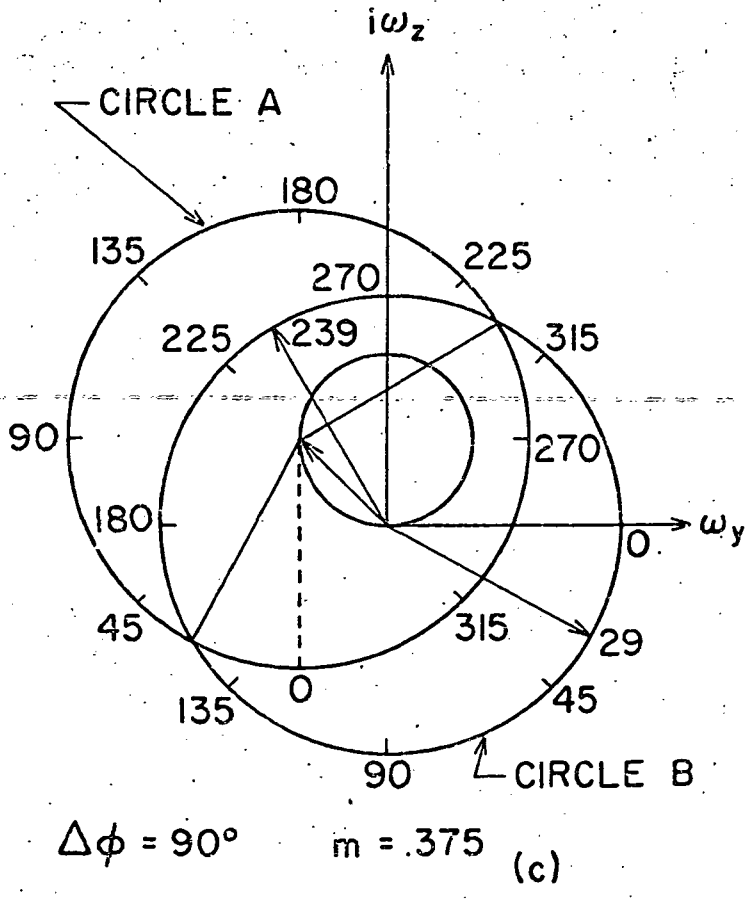
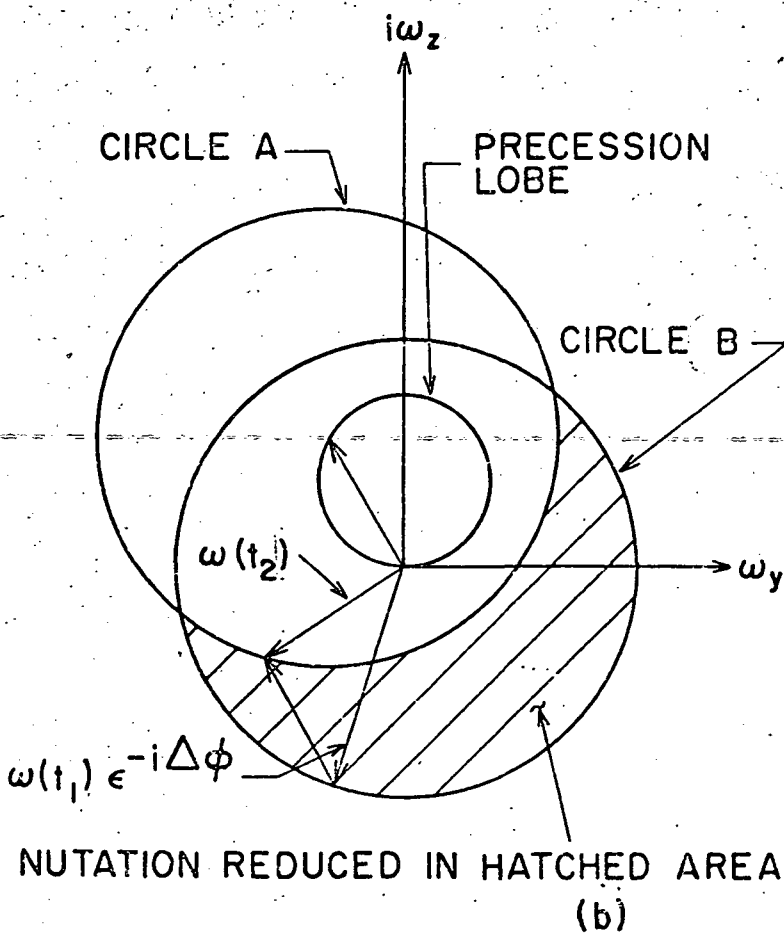
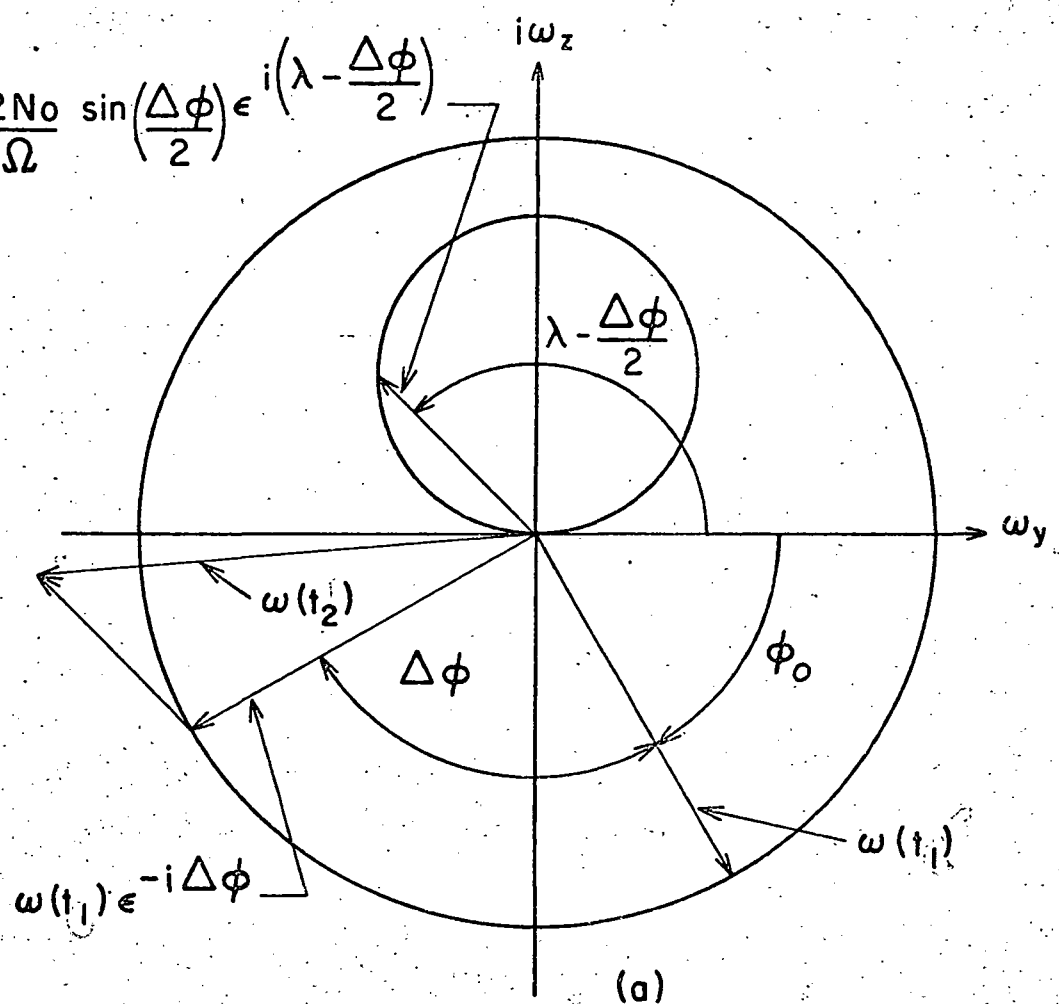

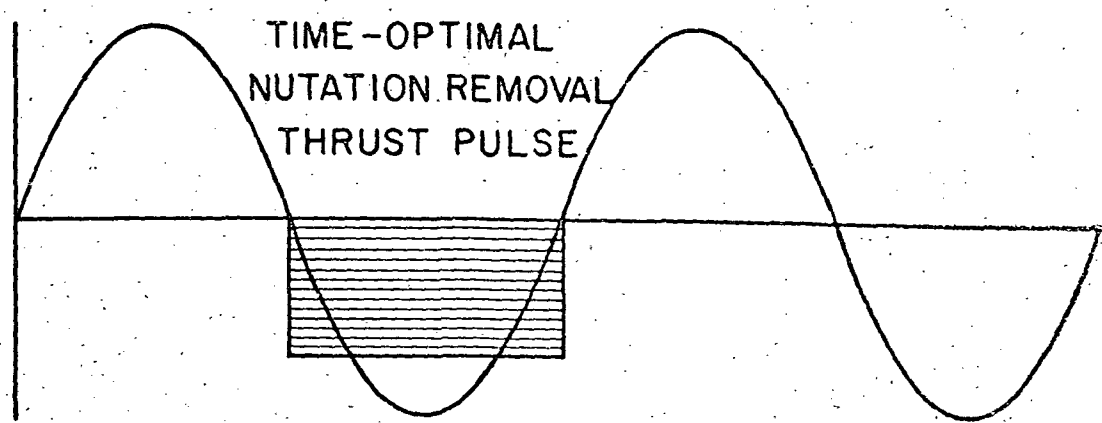

↑ ACCELEROMETER OUTPUT:

$$a = a_0 \theta \sin(\Omega t + \mu)$$

$$a = a_0 \left(\frac{\omega}{\omega_s - \Omega} \right) \sin(\Omega t + \mu)$$

(a)

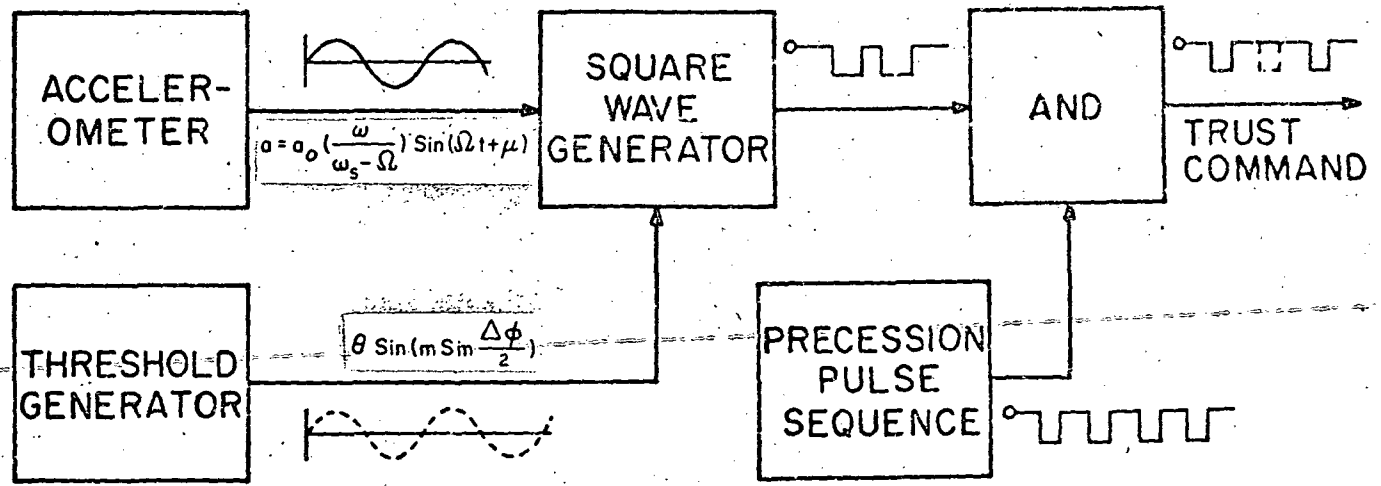

(b)

1.0
1.0

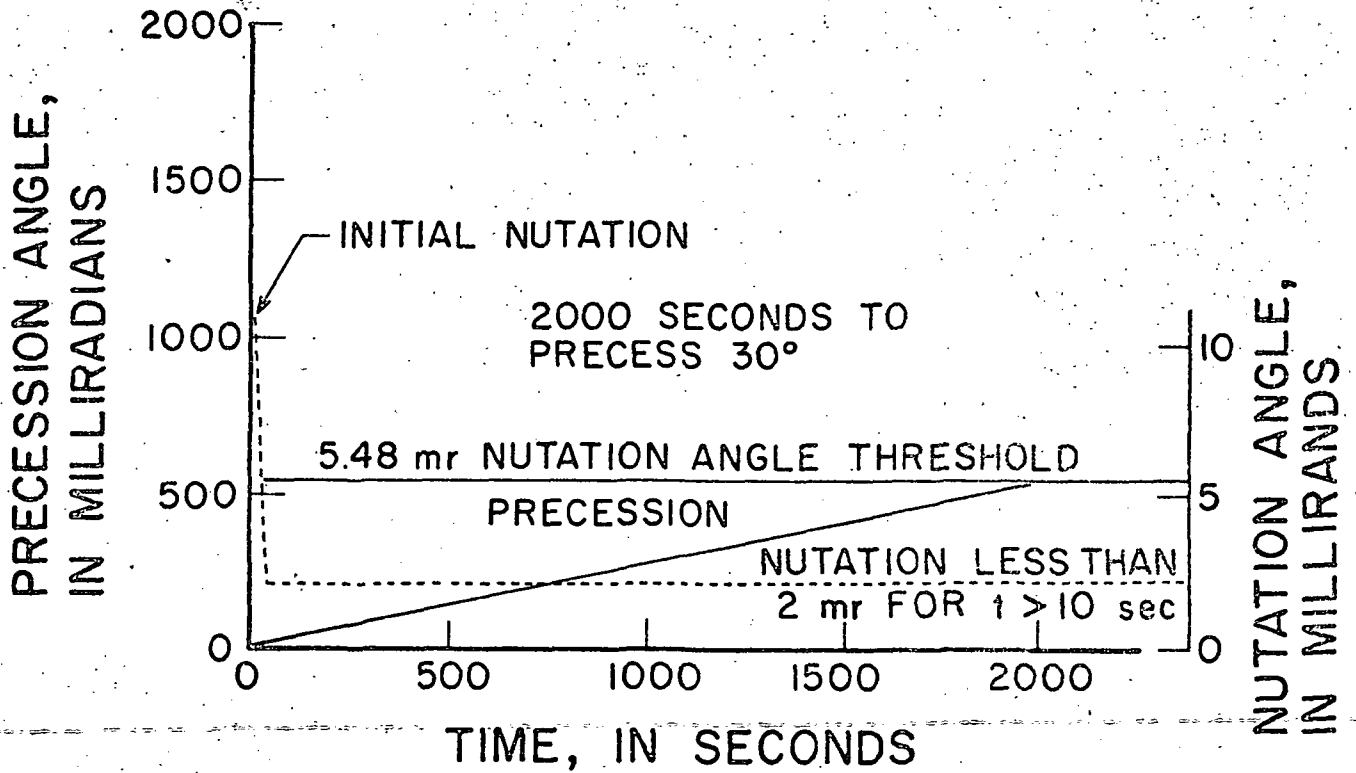

REPRODUCIBILITY OF THE ORIGINAL PAGE IS POOR

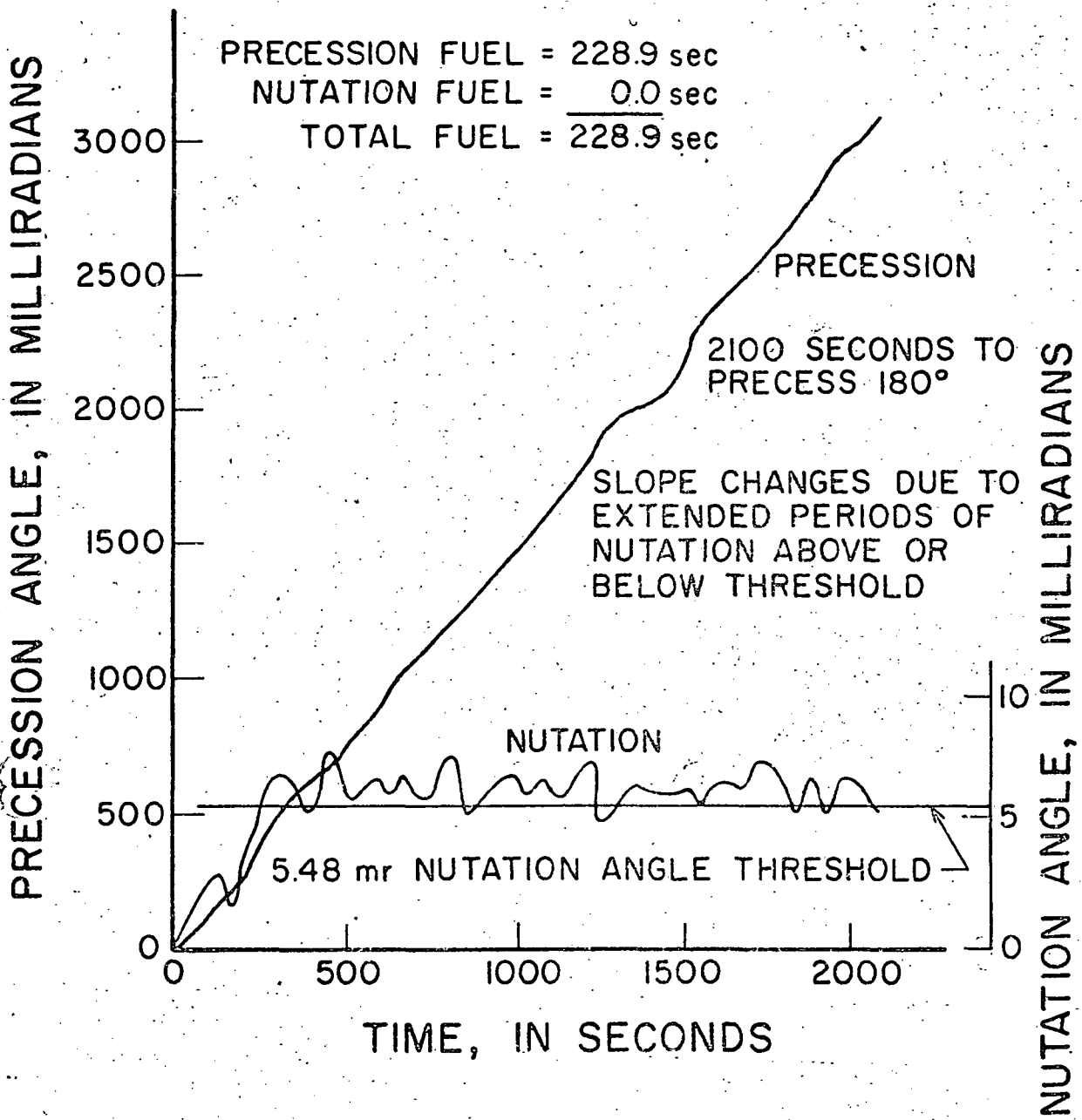

REPRODUCIBILITY OF THE ORIGINAL PAGE IS POOR

FINAL REPORT

NASA GRANT NGR 26-003-069

NUTATION CONTROL DURING PRECESSION
OF A SPIN-STABILIZED SPACECRAFT

DEPARTMENT OF ELECTRICAL ENGINEERING

UNIVERSITY OF MISSOURI - ROLLA

ROLLA, MISSOURI 65401

TECHNICAL REPORT CRL 74.4

JUNE 1974

REPRODUCIBILITY OF THE
ORIGINAL PAGE IS POOR

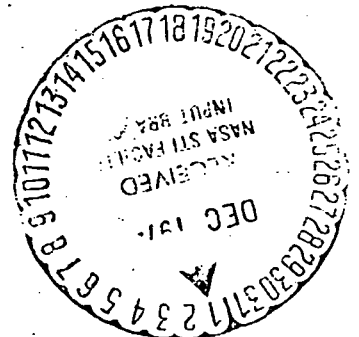

ABSTRACT

This NASA Grant Final Report is divided into two (2) parts. The first part summarizes the main effort of the grant-- to investigate and develop precession maneuver control laws for single-spin spacecraft so that nutation is concurrently controlled. Analysis has led to the development of two (2) types of control laws employing precession modulation for concurrent nutation control. Results have been verified through digital simulation of a Synchronous Meteorological Satellite (SMS) configuration.

In the second part, ^{CR-139154} an addition research effort, not originally considered, was undertaken to investigate the cause and elimination of nutation anomalies in dual-spin spacecraft. A literature search has been conducted and a dual-spin configuration has been simulated to verify that nutational anomalies are not predicted by the existing non-linear model. At the termination of the grant, the dual-spin research is still preliminary and no conclusions can be drawn as to the cause of the observed nutational anomalies in dual-spin spacecraft.

FOREWARD

The research covered by this report is supported by NASA Grant NGR 26-003-069, "Nutation Control During Precession of a Spin-Stabilized Spacecraft". The work was performed by Dr. Javin M. Taylor, Principal Investigator, Richard J. Donner, Master of Science Candidate in Electrical Engineering, and Vehbi Tasar, Master of Science Candidate in Computer Science, at the University of Missouri - Rolla under the supervision of Dr. Thomas W. Flatley, Earth Observations Systems & Systems Engineering Division, Space Applications and Technology Directorate, Goddard Space Flight Center.

This report represents the Final Report for this project as required by NASA Provisions for Research Grants.

TABLE OF CONTENTS

	PAGE
ABSTRACT	ii
FOREWARD	iii
PART I. NUTATION CONTROL IN SINGLE-SPIN SPACECRAFT.	1
PART II. NUTATION ANOMALIES IN DUAL-SPIN SPACECRAFT.	2
APPENDIX A: AIAA-JSR SYNOPTIC--THE USE OF PRECESSION MODULATION FOR NUTATION CONTROL IN SPIN- STABILIZED SPACECRAFT	4
APPENDIX B. BACKUP PAPER--THE USE OF PRECESSION MODULATION FOR NUTATION CONTROL IN SPIN- STABILIZED SPACECRAFT	16
APPENDIX C. PARTIAL BIBLIOGRAPHY ON DUAL-SPIN DY- NAMICS.	39

PART I. NUTATION CONTROL IN SINGLE-SPIN SPACECRAFT

The purpose of Grant NGR 26-003-069 was to investigate variations in the basic precession maneuver control laws for single-spin spacecraft so that nutation is concurrently controlled. Nutation induced by precession was analyzed in detail. Subsequently, two control laws employing precession modulation for concurrent nutation control were developed and verified through digital simulation of a Synchronous Meteorological Satellite (SMS) configuration. Results were reported in the Semi-Annual Status Report "Nutation Control During Precession of a Spin-Stabilized Spacecraft" in December 1973.

Manuscripts describing the research performed in this part of the grant effort have been submitted to the American Institute of Aeronautics and Astronautics Journal of Spacecraft and Rockets in their Synoptic/backup paper format. Appendix A contains the Synoptic manuscript and Appendix B contains the backup paper manuscript, both entitled, "The Use of Precession Modulation for Nutation Control in Spin-Stabilized Spacecraft".

The grant to the University of Missouri - Rolla, through direct financial aid or research involvement, supported the obtainment of the Master of Science in Computer Science degree by Mr. Vehbi Tasar and the Master of Science in Electrical Engineering degree by Mr. Richard J. Donner.

PART II. NUTATION ANOMALIES IN DUAL-SPIN SPACECRAFT

As an additional research effort, not originally considered in Grant NGR 26-003-069, a preliminary study was undertaken to investigate the cause and elimination of nutation anomalies in dual-spin spacecraft. The intent was to look at anomalous nutation behavior in dual-spin spacecraft, in general, and, in particular, with regard to three NASA spacecraft, ITOS-D, ITOS-F, and AE-C. This behavior is characterized by either the decay or growth of induced nutation to some non-zero terminal value.

A literature search was undertaken and a partial bibliography is included in Appendix C. The published literature on dual-spin dynamics generally fails to provide insight into mechanisms which might be responsible for this anomalous nutation behavior. However, [16] describes an effort to determine the cause of apparently similar behavior for a particular dual-spin spacecraft. Mechanical cross-coupling due to dissipation in the bearing assembly connecting the two spinning bodies was identified in this case as the probable cause.

Yet another study [20] pin pointed the cross-coupling mechanism as electronic in nature. Here nutation influenced the position sensor and produced errors in the despin control torque.

Communications with NASA regarding ITOS-D, ITOS-F, and AE-C have also suggested the interface between the spinning

bodies as the area wherein anomalous nutation behavior is generated. Prior to investigating the interface model, the dual-spin configuration described by Phillips [20] was simulated to verify that nutational anomalies were not predicted by the existing nonlinear model. No nutational anomalies were observed in the simulation of the dual-spin model of [20].

At the termination of Grant NGR 26-003-069, the dual-spin research was still in a preliminary stage and no conclusions could be drawn as to the cause of the observed nutational anomalies in dual-spin spacecraft.

APPENDIX A

AIAA-JSR SYNOPTIC--THE USE OF PRECESSION MODULATION FOR
NUTATION CONTROL IN SPIN-STABILIZED SPACECRAFT

THE USE OF PRECESSION MODULATION FOR NUTATION
CONTROL IN SPIN-STABILIZED SPACECRAFT

Javin M. Taylor¹

University of Missouri-Rolla, Rolla, Mo.

Richard J. Donner²

McDonnell-Douglas Corp., St. Louis, Mo.

Vehbi Tasar³

University of Missouri-Rolla, Rolla, Mo.

NOMENCLATURE

a_o	=	accelerometer gain
a	=	accelerometer output
I_x, I_y, I_z	=	moments of inertia about principal axes
N_o	=	torque
T_s	=	spacecraft spin period
T_Ω	=	spacecraft nutation period
α	=	$-1/\tau + i\Omega$, complex energy dissipation
λ	=	angular position of control thruster with respect to spacecraft axes.
$\Delta\phi$	=	thrust pulse duration, in angle of nutation cycle

Received _____; synoptic received _____. Full paper available from National Technical Information Service, Springfield, Va., 22151, as _____ at the standard price (available upon request).

Supported by NASA Goddard Space Flight Center, Grant NGR26-003-069.

Index categories: Earth Satellite Systems, Unmanned; Spacecraft Attitude Dynamics and Control.

1. Assistant Professor, Department of Electrical Engineering
2. Engineer and Master of Science candidate in Electrical Engineering at the Graduate Engineering Center, University of Missouri-Rolla
3. Master of Science candidate, Department of Computer Science

Δt	=	thrust pulse duration, in seconds
μ	=	accelerometer angular position
ϕ_0	=	nutaton phase angle at initiation of thrust pulse
σ	=	measure of moment of inertia ratio between transverse and spin axes
τ	=	energy dissipation time constant
θ	=	nutaton angle
$\omega(t)$	=	transverse angular velocity
ω_s	=	spacecraft spin rate
Ω	=	nutaton frequency

THEME

Spin stabilization is used to inertially fix a spacecraft's thrust vector during a transfer ellipse; however, spin about an axis other than that of maximum inertia results in an unstable equilibrium condition. Energy dissipation resulting from fluid motion in heat pipes and fuel tanks causes the nutation angle to increase. Furthermore, during the transfer ellipse, if it is necessary to precess the spacecraft's spin axis to reorient the thrust vector, this maneuver can also cause nutation to increase.

This paper analytically derives relations which determine the nutation effects induced in a spinning spacecraft by periodic precession thrust pulses. By utilizing the idea that nutation need only be observed just before each precession thrust pulse, a tedious continuous time derivation reduces to a simple discrete-time derivation which can be easily solved through the use of z-transforms.

The analytic results obtained are used to develop two types of modulated precession control laws which use the precession maneuver

to concurrently control nutation.

CONTENTS

In 1968 Grasshoff [1] published the original work on a control law which can be used to sense and remove nutation automatically. Grasshoff's basic differential equation for the transverse angular velocity of the spinning spacecraft is

$$\dot{\omega}(t) + i\Omega\omega(t) = N_0 e^{i\lambda} \quad (1)$$

and the solution for a control thrust duration of $(t_1 - t_0)$ seconds is given by

$$\omega(t_1) = \omega_0 e^{-i\Omega(t_1 - t_0)} + \frac{N_0 e^{i\lambda}}{i\Omega} [1 - e^{-i\Omega(t_1 - t_0)}] \quad (2)$$

Grasshoff defines the nutation angle as the peak value of

$$\theta = \omega(t) / (\omega_s - \Omega). \quad (3)$$

Nutation can be sensed by an accelerometer with sensitive axis parallel to the spacecraft's spin axis and can be removed by properly timing the firing of a small thruster whose thrust axis is also parallel to the spin axis. The sensed acceleration is given by

$$a = a_0 \theta \sin(\Omega t + \mu). \quad (4)$$

Energy dissipation causes nutation to continually increase. For small perturbations, the increase in nutation angle, θ , is generally represented [3] as

$$\theta(t) = \theta_0 e^{t/\tau}, \quad (5)$$

in which τ is the time constant of energy dissipation.

Due to the relationship in (3) between θ and $\omega(t)$, energy dissipation can be included in (1) to give

$$\dot{\omega}(t) + \left(-\frac{1}{T} + i\Omega\right)\omega(t) = N_0 e^{i\lambda} \quad (6)$$

Precession of the spin axis of a spinning spacecraft can be effected by using the same thruster that is required for nutation control. For a precession maneuver consisting of a thrusting sequence of equally spaced thrust pulses that are Δt wide and have a period $T_s = 2\pi/\omega_s$, (1) becomes

$$\dot{\omega}(t) + i\Omega\omega(t) = \begin{cases} N, & n \cdot T_s \leq t < n \cdot T_s + \Delta t, \\ 0, & n \cdot T_s + \Delta t \leq t < (n+1)T_s. \end{cases} \quad n=0,1,2,\dots \quad (7)$$

The continuous solution for (7) is complicated by the essentially infinite pulse train. The inverse Laplace transform of the Laplace transform of (7) is difficult because the pole at $s = -i\Omega$ cannot be separated by a contour from the poles at $\pm i2n\pi/T_s$, $n=1,2,3,\dots$ (See reference [4] for a discussion of Laplace transforms of pulse trains.)

The solution of (7) is straightforward if it is sufficient to know only the result at discrete times, for example, at the discrete point, $k T_s$, just prior to the next thrust pulse. Thus, (7) can be changed to a first-order difference equation. (See reference [5] for a discussion of difference equations and z-transform theory.) By taking the z-transform and then taking the inverse z-transform, the discrete time solution for (1) is

$$\omega[n T_s] = \omega_0 e^{-i\Omega(nT_s)} + \frac{N_0 e^{i\lambda}}{i\Omega} (1 - e^{-i\Omega\Delta t}) e^{-i\Omega T_s} \left[\frac{1}{1 - e^{-i\Omega T_s}} + \frac{e^{-i\Omega(nT_s)}}{1 - e^{i\Omega T_s}} \right] \quad (8)$$

The discrete time solution for (6) can be similarly obtained as

$$\omega[nT_s] = \omega_0 e^{-\alpha(nT_s)} + \frac{N_0 e^{i\lambda}}{\alpha} (1 - e^{-\alpha\Delta t}) e^{-\alpha T_s} \left[\frac{1}{1 - e^{-\alpha T_s}} + \frac{e^{-\alpha(nT_s)}}{1 - e^{\alpha T_s}} \right] \quad (9)$$

where $\alpha = -(1/\tau) + i\Omega$.

The conclusions are that with no energy dissipation and with a judicious choice of inertia ratios, which determine the relationship between T_s and T_Ω , nutation resulting from unmodulated precession is bounded and periodic and can be kept at tolerable levels. With energy dissipation, nutation resulting from unmodulated precession is unbounded. Thus, some sort of nutation control is required during a precession maneuver.

Because precession and nutation control can use the same thruster, precession thrust pulses can be selected that will concurrently reduce nutation. The effect of a single precession pulse on nutation can be demonstrated by a graphic representation of (2) shown in Figure 1a.

The range of the initial position ϕ_0 can be analytically derived from (2). After trigonometric manipulation, replacement of ω_0 by $\omega_0^{-i\phi_0}$, and $(t_1 - t_0)$ by $\Delta\phi$, the expression for the range of ϕ_0 , for which $\omega(t_1) \leq \omega(t_0)$ is given by

$$\arccos[-m \sin(\Delta\phi/2)]_{II}^{-\lambda - (\Delta\phi/2)} \leq \phi_0 \leq \arccos[-m \sin(\Delta\phi/2)]_{III}^{-\lambda - (\Delta\phi/2)}, \quad (10)$$

in which $\arccos [\cdot]_{II}$ and $\arccos [\cdot]_{III}$ refer to angles in the II and III quadrants, respectively, and m is given by

$$m = (N_0/\Omega) (1/\omega(t_0)). \quad (11)$$

To summarize, (10) shows that a relation exists which can be used to modulate, or gate, the precession pulse train so that only precession pulses are allowed which concurrently reduce nutation.

In fact, the nutation sensing accelerometer discussed previously and a threshold derived from (10) can be used to provide precession pulse gating.

Figure 1b shows the use of the accelerometer output for time-optimal nutation control. Any thrust which has a pulse duration of less than π/Ω but occurs during the negative half-cycle of the accelerometer output, will also reduce nutation, but suboptimally.

Figure 1c is a block diagram of a modulated precession, nutation control. The end result is that only precession pulses that concurrently reduce nutation are passed to the thruster.

Two precession modulation nutation control methods are now presented. The first provides continuous precession modulation, and the second allows unmodulated precession until nutation increases to a threshold value at which time the precession is modulated. The corresponding figures show digital computer simulation results of these control laws applied to the Synchronous Meteorological Satellite (SMS) configuration specified as follows: mass properties: mass = 42.8 slugs, $I_x = 244.4$, $I_y = 246.9$, $I_z = 97.3$, all in slug-feet², $\sigma = 0.6039$; angular velocity: $\omega_s = 90$ rpm, $\Omega = 5.69$ rad/sec; thruster properties: thrust = 5 lbs., moment arm = 3 feet, duty cycle for precession = 1/12 second (45° of spin period), duty cycle for nutation = 0.552 seconds (1/2 nutation period); energy dissipation time constant: $\tau = 180$ seconds.

Figure 2a shows the behavior for the continuous precession modulation nutation control. Because the gate width, as given in (10), varies inversely with nutation, the precession increase and nutation decrease will be fairly rapid initially. As the nutation reduces,

fewer precession pulses are passed, and the increase in precession with respect to time reduces to the constant rate shown. Consequently, as shown in Figure 2a, 2000 seconds are required to precess 30° , but after the first ten seconds of the precession maneuver nutation remains below 2 milliradians.

Figure 2b shows the behavior for the nutation control law which allows unmodulated precession until nutation increases to a threshold value of 5.48 milliradians at which time the precession is modulated. Thus, the precession and nutation increase until the nutation threshold is reached. At this time, precession modulation occurs. The slope of the precession increase diminishes as the result of precession modulation, and the nutation is held near the threshold level.

In the second case the control law passes all precession pulses until nutation builds up to a threshold of 5.48 milliradians. Consequently, precession is more rapid. As figure 2b shows, 2100 seconds are required to precess the entire 180° .

By way of contrast, a simulation of a conventional control law which allows nutation control or precession, but not concurrently, for the SMS configuration described requires 1990 seconds to precess 180° . The fuel budget for the modulated precession control law shown in Figure 2b is 228.9 seconds of thruster fuel. For the conventional type of precession and nutation control the fuel budget is 307.9 seconds of thruster fuel.

In conclusion, for spacecraft such as those described by Grasshoff [1], and Taylor [2], for the SMS, and others emphasizing active on-board nutation control with an accelerometer as the nutation sensing element, the mechanization of the control laws which use the precession

maneuver to concurrently control nutation is straightforward and requires little additional electronic circuitry.

REFERENCES

1. Grasshoff, L. H., "An Onboard, Closed-Loop, Nutation Control System for a Spin-Stabilized Spacecraft," Journal Spacecraft and Rockets, PP. 530-535, May 1968.
2. Taylor, J. M., "The SAS-D Nutation Control System," NASA Technical Document X-732-72-196, Goddard Space Flight Center, Greenbelt, Maryland, June 1972.
3. Alfriend, K. T., "Analysis of a Partially Filled Viscous Ring Damper," NASA Technical Document X-732-71-456, Goddard Space Flight Center, Greenbelt, Maryland, October 1971.
4. Gupta, S. C., Transform and State Variable Methods in Linear Systems, Wiley and Sons, 1966.
5. Tou, J. T., Digital on Sampled-data Control Systems, McGraw-Hill, 1959.

FIGURE CAPTIONS

- Figure 1. (a) Graphic Representation of Equation (2).
(b) Nutation Sensing Accelerometer Output.
(c) Modulated Precession Nutation Control.

- Figure 2. (a) SMS Simulation For Full Modulated Pre-
cession Nutation Control.
(b) SMS Simulation For Full-Precession-to-
Threshold Modulated Precession Nutation
Control.

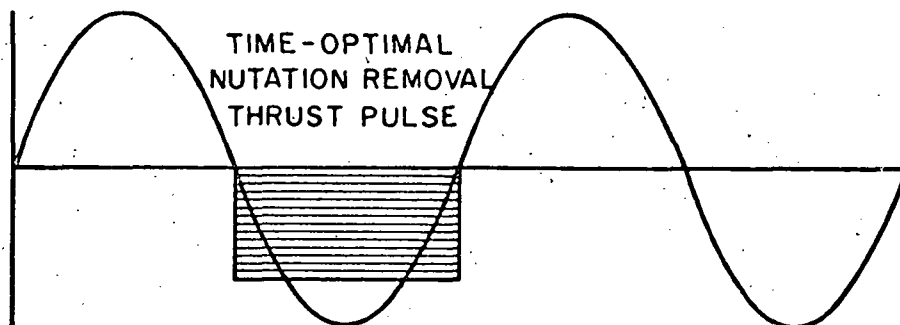
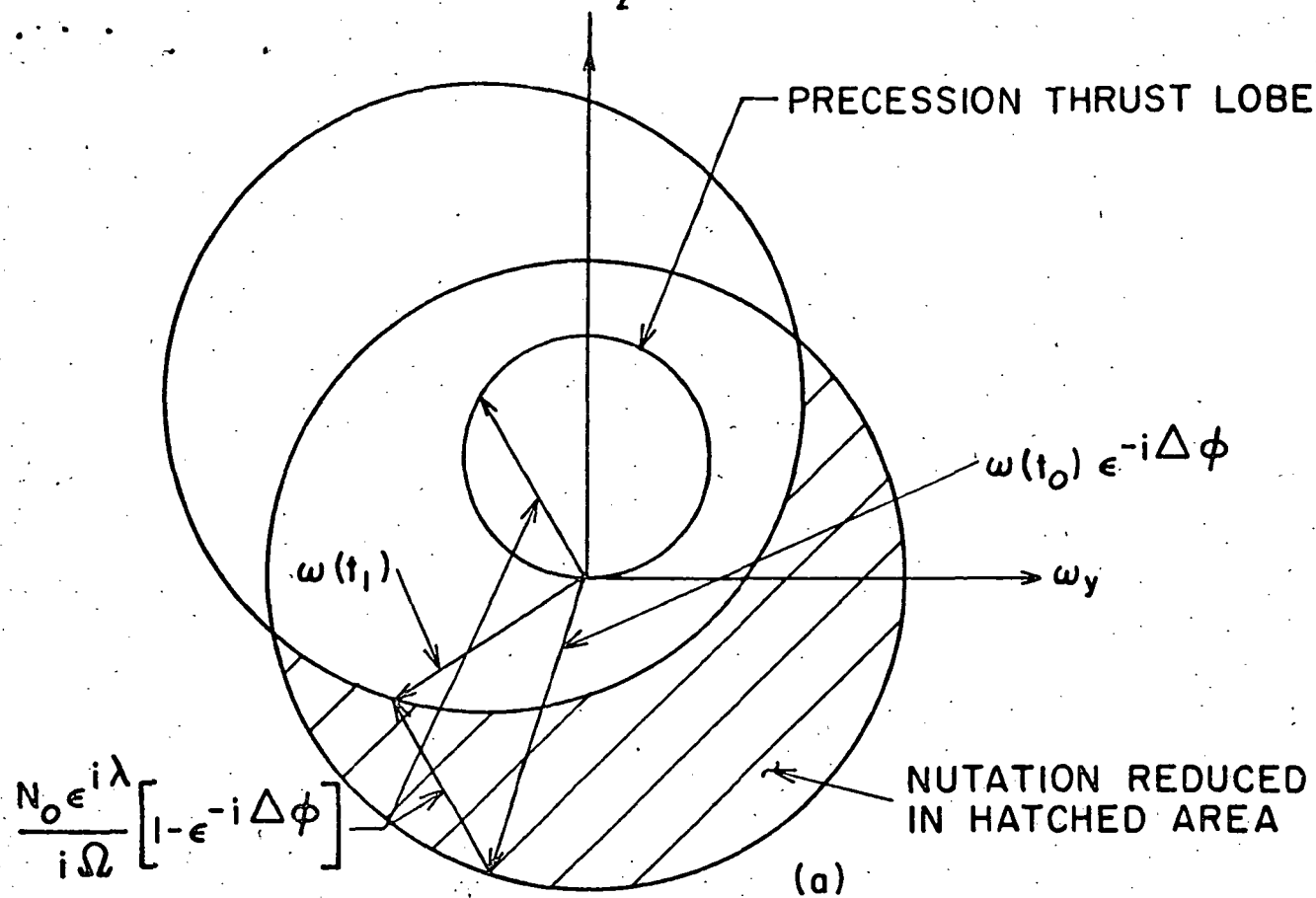

ACCELEROMETER OUTPUT:

$$a = a_0 \theta \sin(\Omega t + \mu)$$

$$a = a_0 \left(\frac{\omega}{\omega_s - \Omega} \right) \sin(\Omega t + \mu)$$

