

NASA-CR-134664

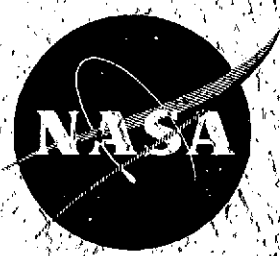

**FABRICATION
OF
TUNGSTEN WIRE REINFORCED
NICKEL-BASE ALLOY COMPOSITES**

by
**W.D. BRETNALL
I.J. TOH**

(NASA-CR-134664) FABRICATION OF TUNGSTEN N75-11075
WIRE REINFORCED NICKEL-BASE ALLOY
COMPOSITES (TRW Equipment Labs.) 60 p
HC \$4.25 CSCL 11/6
G3/26 53868
Unclas

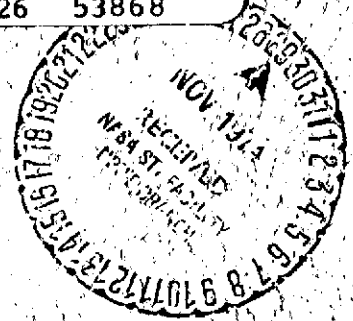

prepared for
NATIONAL AERONAUTICS AND SPACE ADMINISTRATION
NASA Lewis Research Center
Contract NAS 3-16756

D.W. PETRASEK, Project Manager

1. Report No. NASA CR-134664	2. Government Accession No.	3. Recipient's Catalog No.	
4. Title and Subtitle FABRICATION OF TUNGSTEN WIRE REINFORCED NICKEL-BASE ALLOY COMPOSITES		5. Report Date October 1974	6. Performing Organization Code
		8. Performing Organization Report No. ER-7757	
7. Author(s) W. D. Brentnall and I. J. Toth		10. Work Unit No.	11. Contract or Grant No. NAS 3-16756
9. Performing Organization Name and Address TRW INC. Cleveland, Ohio 44117		13. Type of Report and Period Covered Contractor Report.	
		14. Sponsoring Agency Code	
12. Sponsoring Agency Name and Address National Aeronautics and Space Administration Washington, D. C. 20546		15. Supplementary Notes Project Manager, D. W. Petrusek NASA Lewis Research Center, Cleveland, Ohio 44135	
16. Abstract Fabrication methods for tungsten fiber reinforced nickel-base superalloy composites were investigated. Three matrix alloys in pre-alloyed powder or rolled sheet form were evaluated in terms of fabricability into composite monotape and multi-ply forms. The utility of monotapes for fabricating more complex shapes was demonstrated. Preliminary 1093°C (2000°F) stress rupture tests indicated that efficient utilization of fiber strength was achieved in composites fabricated by diffusion bonding processes. The fabrication of thermal fatigue specimens is also described.			
17. Key Words (Suggested by Author(s)) Composites Tungsten Fiber Nickel Base Superalloy Fabrication Stress Rupture		18. Distribution Statement Unclassified - unlimited	
19. Security Classif. (of this report) Unclassified	20. Security Classif. (of this page) Unclassified	21. No. of Pages 55	22. Price* \$3.00

* For sale by the National Technical Information Service, Springfield, Virginia 22151

FOREWORD

The work described in this report was performed in the Materials Technology Laboratory of TRW Inc. under sponsorship of the National Aeronautics and Space Administration, Contract NAS 3-16756. The Principal Investigator was Mr. W. D. Brentnall with technical contributions by Dr. S. T. Scheirer and Mr. D. J. Moracz. The NASA Technical Manager was Mr. D. W. Petrsek.

The TRW Report Number is ER-7757.

ABSTRACT

Fabrication methods for tungsten fiber reinforced nickel-base superalloy composites were investigated. Three matrix alloys in pre-alloyed powder or rolled sheet form were evaluated in terms of fabricability into composite monotape and multi-ply forms. The utility of monotapes for fabricating more complex shapes was demonstrated. Preliminary 1093°C (2000°F) stress rupture tests indicated that efficient utilization of fiber strength was achieved in composites fabricated by diffusion bonding processes. The fabrication of thermal fatigue specimens is also described.

TABLE OF CONTENTS

	Page No.
1.0 INTRODUCTION	1
2.0 TECHNICAL BACKGROUND	2
2.1 Limitation of Current Blade and Vane Materials . . .	2
2.2 Application of Composites to Gas Turbine Material Problems	2
2.3 Properties of Ni-W Composites	5
2.4 System Selection	6
2.5 Fabrication Methods	13
2.6 Powder Processes	15
2.7 Blade Fabrication Processes	16
3.0 EXPERIMENTAL PROGRAM	18
3.1 Material Procurement and Inspection	18
3.2 Evaluation of Processing Methods	21
3.3 Stress Rupture Specimen Fabrication and Testing . .	35
3.4 Fabrication of Thermal Fatigue Specimens	44
4.0 SUMMARY AND CONCLUSIONS	54
5.0 REFERENCES	55

1.0 INTRODUCTION

The continued trend in both military and commercial aircraft is toward turbo-fan engines having a compact, high temperature gas generator. To improve efficiency there is a need to simultaneously increase the compressor pressure ratio to 40 and above and turbine inlet temperatures (T.I.T.) up to values corresponding to stoichiometric combustion. One of the major limiting items in the development of advanced engines is the availability of high temperature materials which have the required oxidation resistance and mechanical properties.

Superalloys have been developed that have high strength at temperatures up to 975°C (1800°F). There is, however, a need for high-strength materials at temperatures of 1093°C (2000°F) and above for applications such as advanced airbreathing engine components. Such applications also require that the material have good oxidation resistance. Superalloys lack strength above 975°C (1800°F), but are oxidation resistant. Refractory metal alloys such as those of tungsten, molybdenum, columbium, and tantalum have sufficient strength at temperatures of 1093°C (2000°F) and above but lack oxidation resistance.

Compositing offers the opportunity to "tailor make" a material for a specific temperature/stress environment. The concept of selecting a matrix to provide the desired oxidation resistance and using a compatible filamentary reinforcement to provide the desired specific strength is currently receiving more attention.

Refractory metal fiber-reinforced metal matrix composites, in particular tungsten/nickel-base superalloys have been made by NASA and others. NASA investigators demonstrated that such materials can have 100-hour stress-rupture strengths superior to conventional superalloys at use temperatures of 1093°C (2000°F) and 1204°C (2200°F). In order to use these advanced high temperature composites, cost effective fabrication methods must be developed.

It was the goal of this program to fabricate tungsten fiber reinforced nickel-base alloy composites, having properties at least equivalent to those developed previously, using advanced processing methods. In addition to the slip casting - hot isostatic pressing process developed by NASA (1), two advanced fabrication processes were investigated. These were press diffusion bonding and roll diffusion bonding using matrix alloys in the form of pre-alloyed powder or rolled sheet. Three matrix alloy compositions were evaluated, in terms of fabricability, with one tungsten fiber composition. Preliminary stress rupture tests were performed, and after further process optimization studies, thermal fatigue specimens were fabricated and delivered to NASA.

The technical background for this work and results from the process evaluation, process optimization, stress rupture tests and thermal fatigue specimen panel fabrication evaluations are discussed in the following sections.

2.0 TECHNICAL BACKGROUND

The technical background for this program is briefly reviewed in the following paragraphs.

2.1 Limitations of Current Blade and Vane Materials

Manson (2) recently reviewed the trends in materials research. In reference to superalloys used in the turbine section of advanced jet engines, the conflict between improved stress rupture property requirements and high temperature oxidation corrosion resistance requirements was illustrated. Figure 1 from Manson's paper shows how the limiting corrosion temperature has decreased with increasing stress rupture strengths. The decreased corrosion resistance arises because of the need to reduce the Cr level from the basic 80Ni-20Cr composition in order to add Al, Ti and refractory elements for improved strength. The strongest alloys shown in Figure 1 are limited to about 975°C (1800°F) for uncoated applications.

The continued development of protective coatings for Ni and Co base superalloys has encouraged the development of stronger (more highly alloyed) materials. Evaluations such as those by Moore, Brentnall and Stetson (3) have shown that the best commercially available coating systems used on alloys such as IN-100 can provide lives of only about 200 hours at 1090°C (2000°F) under simulated gas turbine conditions. More oxidation resistant alloys (B 1900) with the same coating system had significantly longer lives at 1090°C (2000°F) metal temperatures.

None of the currently available superalloys, including directionally solidified materials, have sufficiently high 1090°C (2000°F) stress rupture properties for turbine blade requirements.

Refractory alloys having attractive specific strength properties in this temperature range are available. Very high oxidation rates and lack of reliability of current coating systems are problems which have not been solved, so that these materials are not yet candidates for engine applications.

Compositing offers the opportunity to "tailor make" a material for a specific temperature/stress environment. The concept of selecting a matrix to provide the desired oxidation resistance and using a compatible filamentary reinforcement to provide the desired specific strength or (in the case of ceramics) improved impact and thermal fatigue properties, is currently receiving more attention.

2.2 Application of Composites to Gas Turbine Material Problems

Fiber reinforced composites are high on the list of potential materials for applications in advanced jet engines for high performance aircraft. In

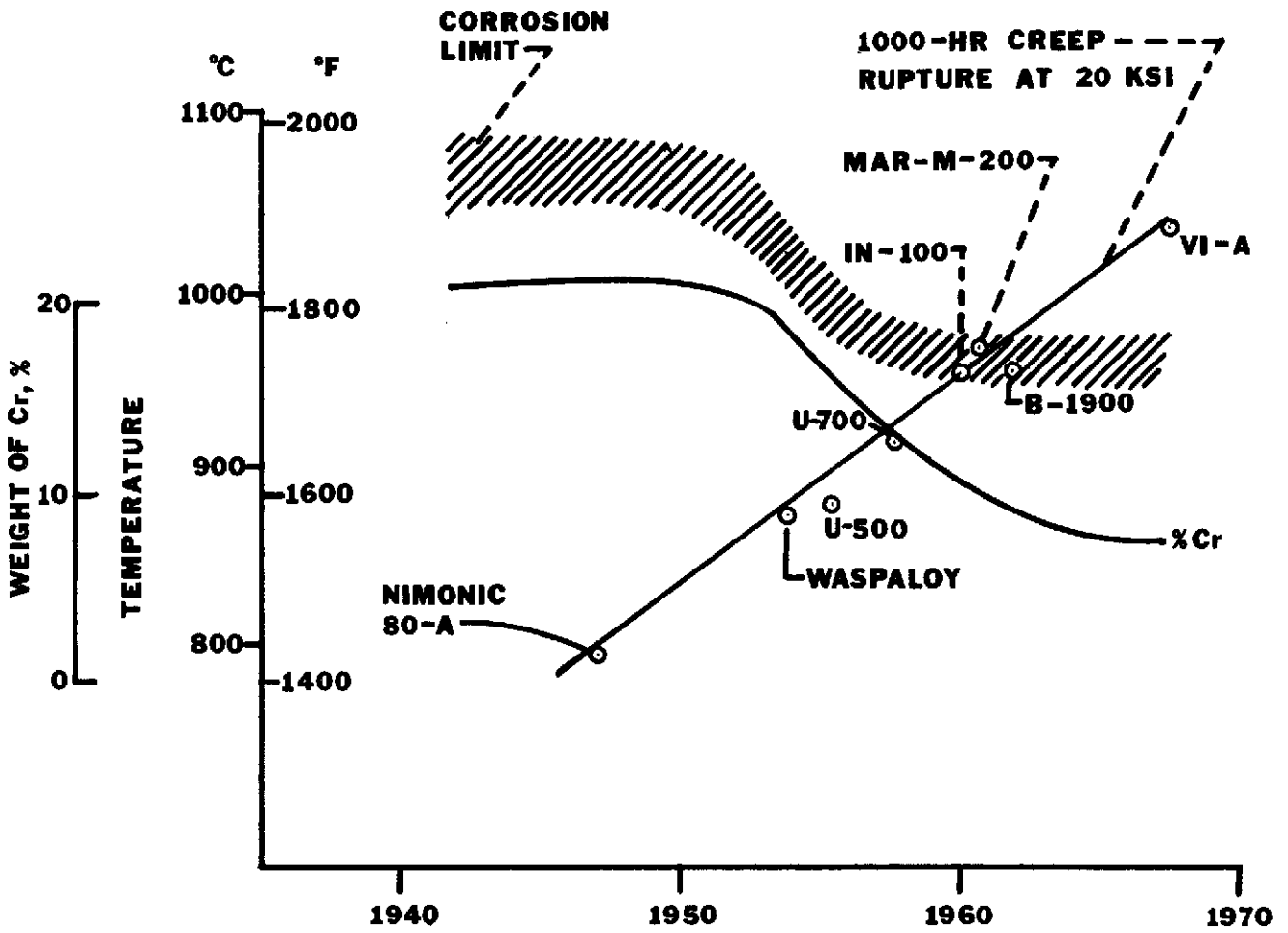

Figure 1. Basis of Corrosion Barrier for Nickel-Base Alloys.
(Ref. 2)

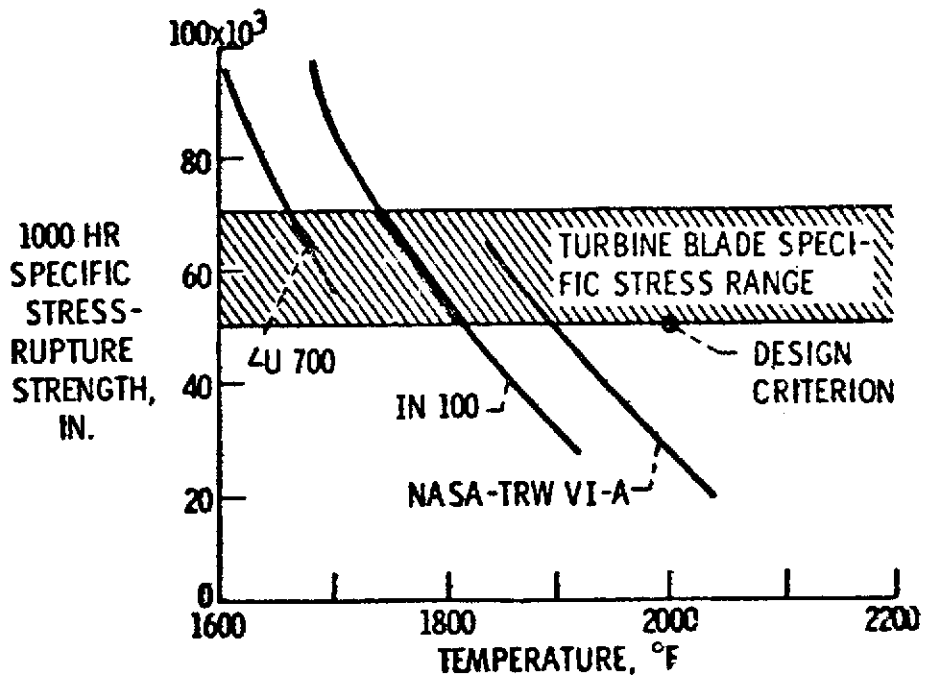

Figure 2. Specific Stress Rupture Strengths of Superalloys Against Temperature. The Superimposed Specific Stress Range is Equivalent to that for Nickel or Cobalt Base Superalloys Stressed Between 15,000 and 20,000 psi. In Addition, Design Criterion for Calculated Fiber Strengths is Indicated. (Ref. 4)

turbine fan and compressor sections very large airfoils are required and the prime requirement is for blade materials with high specific stiffness. In the turbine section, materials with higher temperature capabilities are needed and the limiting material properties are specific strength (creep and stress rupture) and oxidation resistance. Figure 2 is reproduced from a paper by Weeton (4) and shows the 1000 hour specific stress rupture strength requirements for turbine blades between 870-1204° (1600 -2200°F). It is evident that the conventional superalloys do not have the required strengths above about 1000°C (1900°F).

The most extensively developed high temperature, metal matrix composite system is the W/Ni alloy system and the major part of these investigations were performed by NASA (1,4,5,13). The effects of matrix composition on fiber-matrix interaction and of wire size and volume fraction, on stress rupture properties were determined and provided an excellent basis for further development of these systems. The influence of these factors are discussed in more detail in the next section. At the current level of technology these systems represent a 110C° (200F°) improvement over currently used superalloys (based on 1000 hour stress rupture strength).

In other investigations (6,7), a casting technique was used to produce W fiber reinforced 713 C. The fabrication process necessitated the use of very large diameter fibers (to prevent buckling) and only low volume fraction reinforcements (up to 20 v/o) were investigated. Significant improvements in creep strength were reported, however, without loss of fatigue strength.

Other metal matrix systems which have been investigated include Al₂O₃/NiChrome, W/Cr alloys and FeCrAlY reinforced with Mo, W and other fibers. FeCrAlY matrix composites are currently being evaluated (8) for 1204°C (2200°F) (and above) applications.

2.3 Properties of W/Ni Alloy Composites

Because of the excellent creep and stress rupture properties of tungsten lamp filament materials, their potential use as reinforcements has been recognized for many years. Early attempts to combine the excellent oxidation resistance of nickel alloys with the high strength of tungsten filaments indicated that rule of mixtures tensile and creep strengths could not be attained. Casting techniques were used to fabricate these composites however and alloying reactions occurred between fibers and matrix with subsequent loss of properties. Tungsten filament strength-degrading reactions with the matrix can also occur in the solid state due to the presence of nickel and other elements, but the mechanism of the reaction is not fully understood. The heavily cold-worked, fibered structure of drawn tungsten filaments is responsible for their extremely high strength. Consequently, the finer the wire, the higher is its tensile and creep strength. Dopants and dispersoids are added to high strength lamp filaments to stabilize the substructure and under normal conditions these materials are stable to extremely high temperatures. The presence of certain metallic species can cause low temperature recrystallization of the cold worked tungsten (9) resulting in lower strengths and higher ductile-brittle transition temperatures.

The development of the powder slip casting process by NASA for the fabrication of W/Ni composites solved the liquid phase alloying problem. Subsequent work showed that alloying of the matrix with tungsten, aluminum and titanium was effective in reducing the solid state filament-matrix reaction rate by reducing the chemical activity of nickel. Optimization of the fiber diameter in order to maximize 1000 hour, 1090°C (2000°F) stress rupture strength was also achieved and it was shown that there is a trade-off in terms of fiber strength and depth of unavoidable reaction.

The HfC strengthened Mo and W alloys developed by Klopp et al (10) were further developed by Westinghouse under NASA funding (11) specifically for composite applications. Some of the most recent stress rupture data for W-Hf-C/Ni alloy composites from the work of Petrusek and Signorelli (12) are shown in Figure 3. On a specific strength basis and compared to conventional superalloys, the composites were over three times as strong for 100-hour rupture and over four times as strong for 1000-hour rupture (data extrapolated from 400 hours) at 1090°C (2000°F) test temperatures. Figure 4 (from Reference 4) compares current and projected Ni alloy-W composite stress rupture properties. The 1093°C (2000°F) stress rupture strength of a Ni-W-Cr-Al-Ti/W-Hf-C composite represents an enormous improvement over currently available materials.

2.4 System Selection

The work at NASA and elsewhere has established principles and guidelines for selection of fibers and matrices for high temperature nickel composites. This background was considered when selecting potential systems. Equally important, however, was a consideration of the cost and ease of fabrication into useful hardware such as blades and vanes. It was believed that this total cost picture should be analyzed at the outset so that the penalties for improved performance would be economically acceptable.

The general criteria for system selection are discussed briefly in the following paragraphs.

Selection of Reinforcement

The most important requirements for reinforcing fibers are high creep strength, microstructural stability and compatibility with the matrix at temperatures up to 1200°C (2200°F). Tungsten filaments have the highest elevated temperature strengths and have the lowest reaction rates with nickel alloys of any readily available continuous filaments. Most of the development work on tungsten filaments has been for applications at temperatures of 1645-2200°C (3000-4000°F). The work in Reference 11 produced material having significantly improved properties at 1093°C (2000°F) and filled what had previously been a blank in tungsten filament technology. These W-Hf-C filaments therefore were a logical choice for 1093°C (2000°F) composite applications. Because of very limited availability of these advanced fibers,

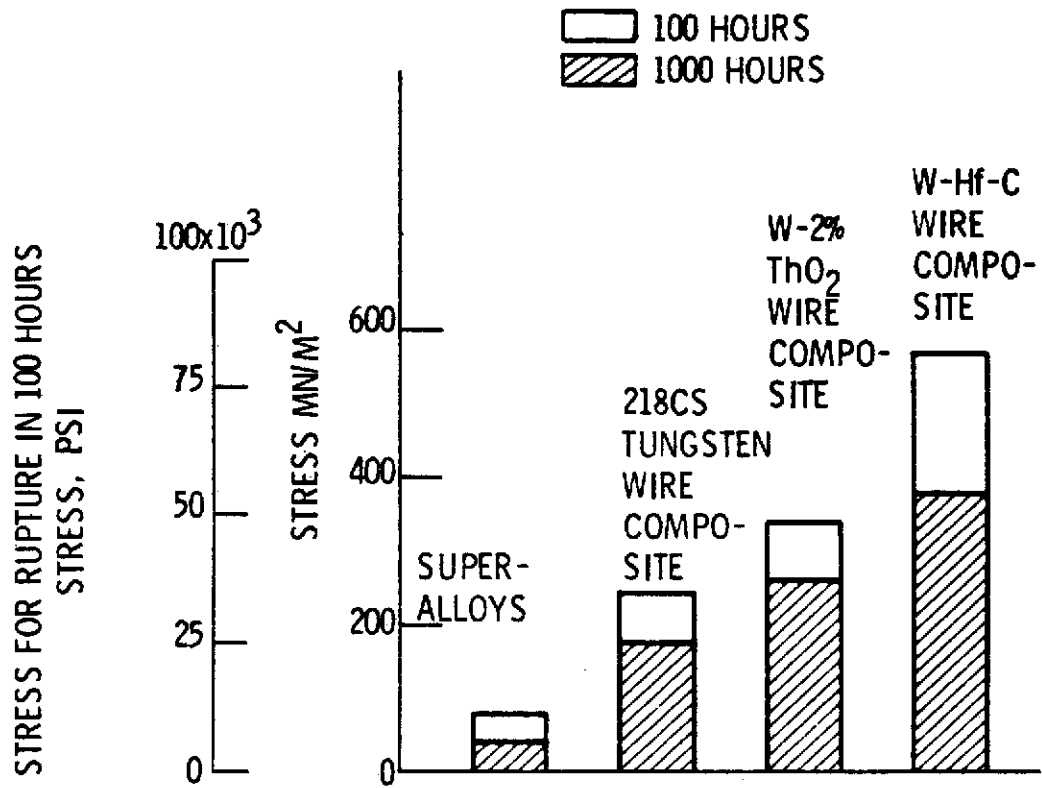

Figure 3. A 100-Hour and 100-Hour Rupture Strength for Refractory Wire - Nickel Base Alloy Composites at 1093°C (2000°F). Fiber Content = 70 Volume Percent. (Ref. 12)

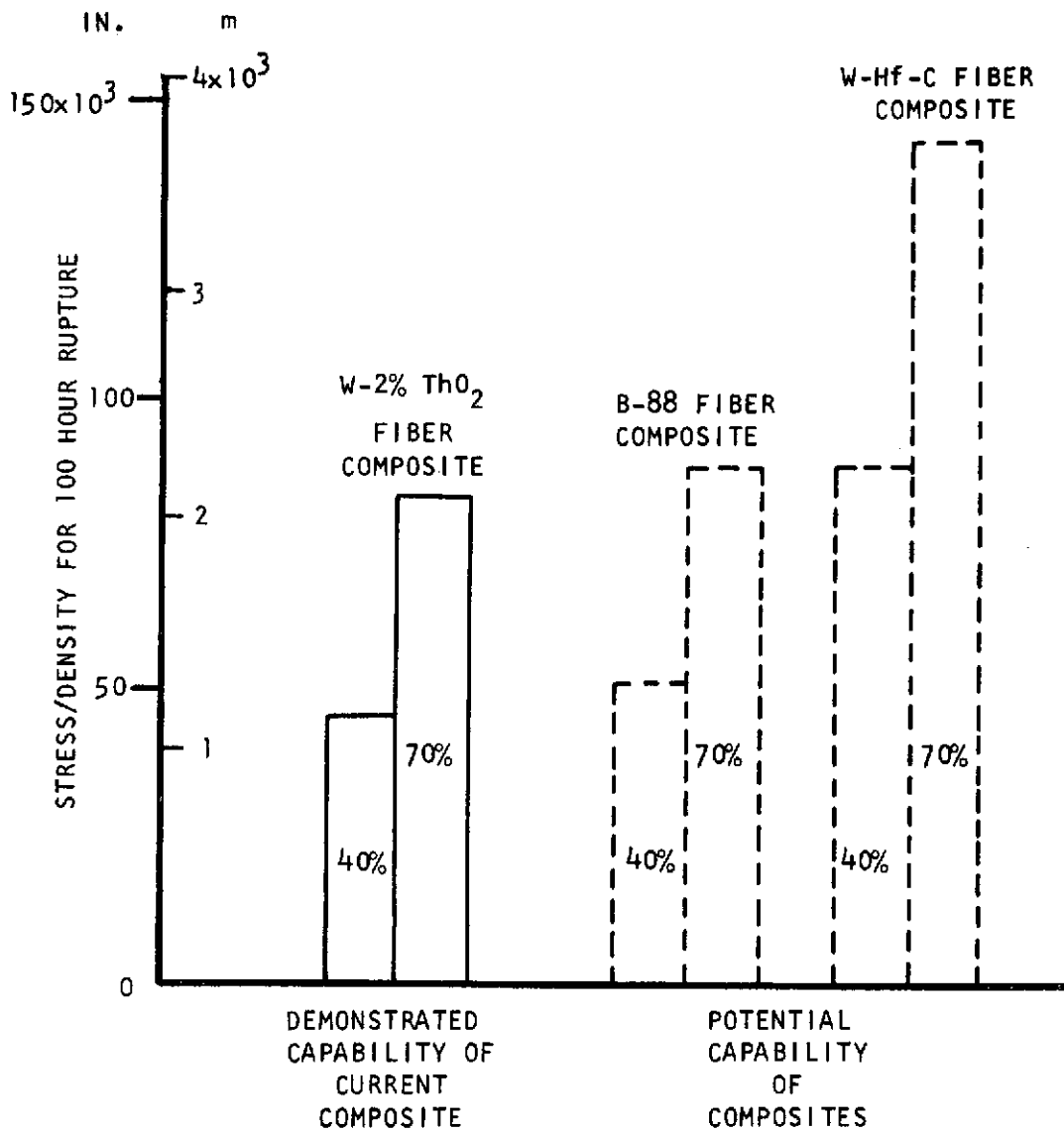

Figure 4. Demonstrated and Potential Values of Specific Creep-Rupture Strengths of Refractory Metal Fiber Reinforced Superalloy Composites at 1093°C (2000°F). (Ref. 4)

however, and because the NASA work had generated data using mostly 218CS tungsten wire, the same material (218CS.W) was selected for these process evaluation studies.

Unless diffusion barrier coatings are used on the fibers, some reaction of fibers with the nickel alloy matrix is unavoidable. The work by Petrasek, Signorelli and Weeton⁽¹⁾ defined optimum wire diameter (218CS) in terms of degree of reaction and in situ fiber stress-rupture properties. For the most compatible matrix which produced a 0.001 inch reaction depth after 1000 hours at 1090°C (2000°F), the optimum fiber diameter was defined as about 0.015 inch. These data are reproduced in Figure 5.

In defining optimum wire size, fabricability should also be considered. For instance, large diameter filaments may be easier to distribute uniformly, in the slip casting process, but may be slightly more difficult to collimate than small diameter filaments by conventional winding processes. In addition to higher (initial) strength, smaller diameter filaments can be more efficiently used to reinforce turbine blades which have relatively small cross sections. In considering strength, reactivity, and fabricability, a fiber diameter of 0.010 to 0.020 represents an optimum selection. Thus, 15 mil dia. was selected. Because of cost, 218CS was used rather than W-Hf-C since this was a process development program.

Selection of Matrix

The matrix requirements are more complex since there has to be a tradeoff between conflicting parameters. Some of the more important requirements are:

1. Compatibility with fibers - chemical and physical.
2. Oxidation resistance at 1093°C (2000°F).
3. Sufficient shear strength for stress transfer to the filaments.
4. Fabricability.
5. Diffusion bondability.
6. Ductility (for good impact resistance).
7. Ability to be coated.
8. Good thermal fatigue properties.

The development of suitable reaction barrier coatings (currently in progress) may reduce the importance of Requirement No. 1 but successful coating development cannot, at this stage, be relied upon.

There was both agreement and conflict between requirements 1 and 2. Tungsten and aluminum additions act to reduce the Ni chemical potential and therefore result in reduced fiber-matrix reaction rates, ^(1,5). High tungsten additions impair oxidation resistance, however, but aluminum is essential for good oxidation resistance at 1090°C (2000°F).

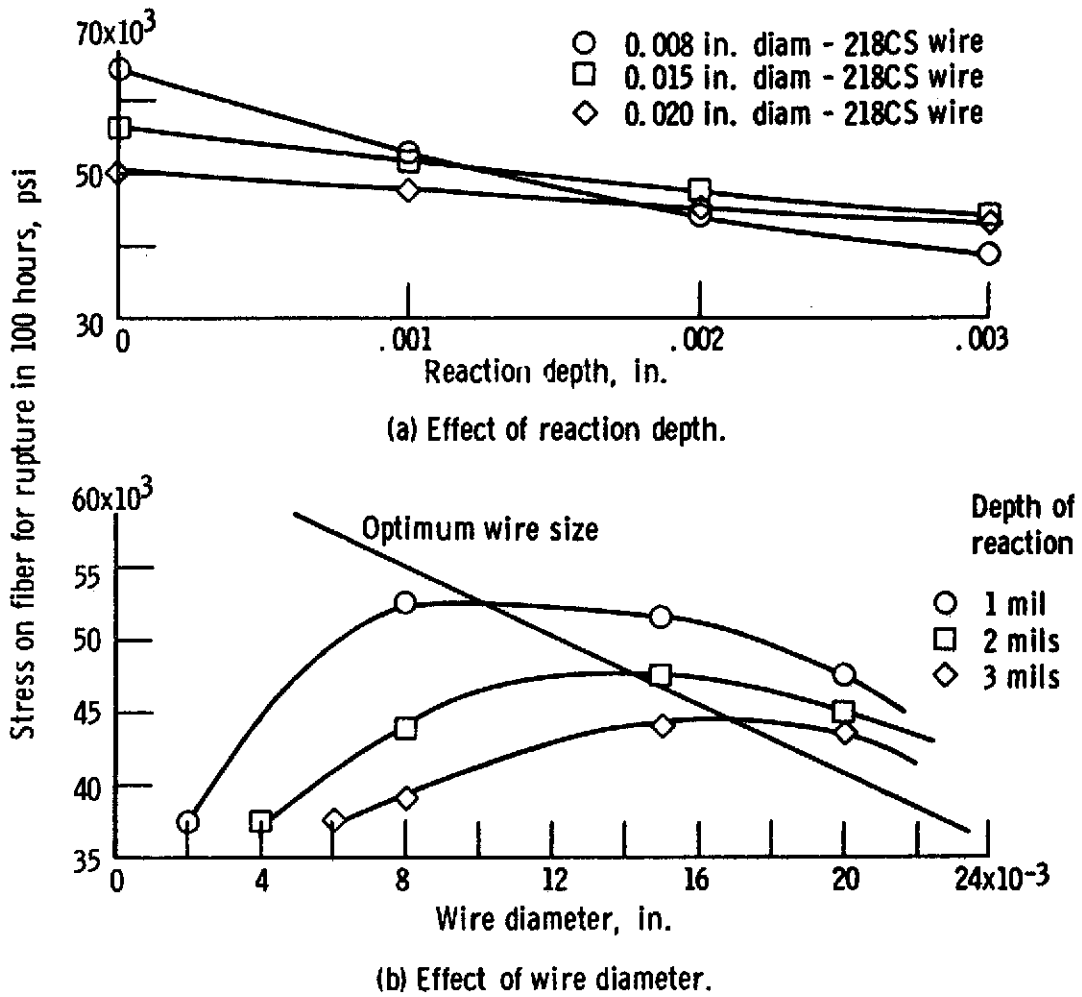
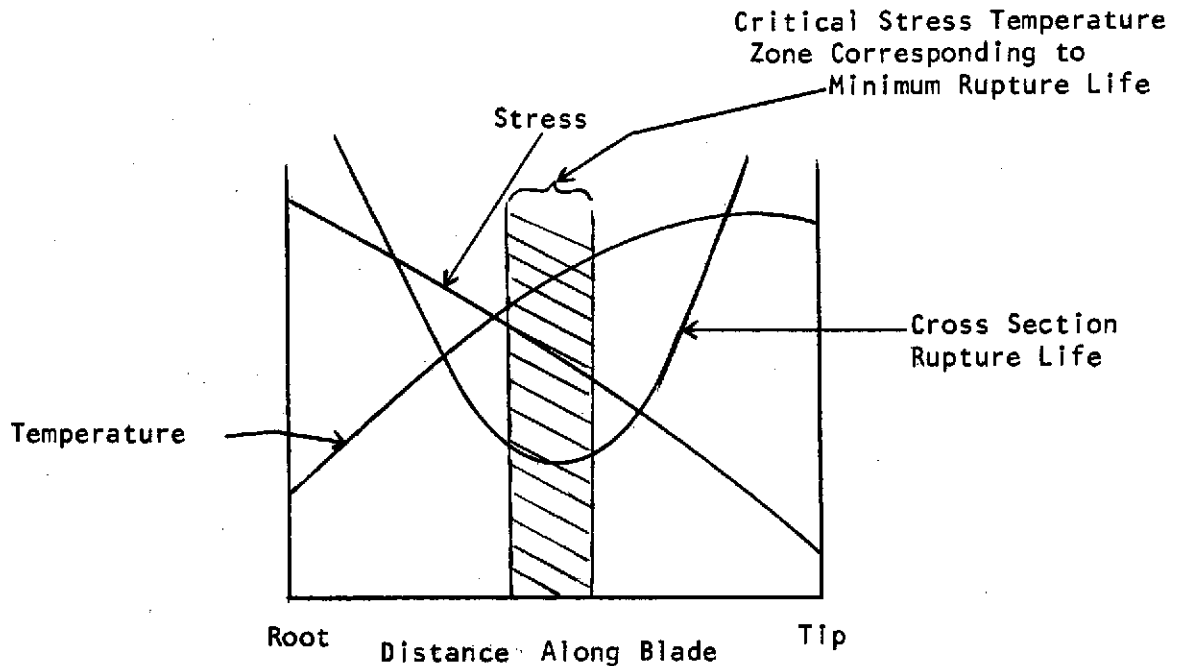

Figure 5. Calculated 100-Hour Rupture Strength of Wire at 1093°C (2000°F) as a Function of Wire Diameter and Depth of Penetration. (Ref. 1)

The shear strength requirement may be an extremely low value since with continuous filaments there is a large shear stress transfer area. Turbine blade root attachment may dictate the limiting stress requirement and therefore the critical stress-temperature zone in the blade should be defined. Stress and temperature vary inversely along the length of a blade with maximum stress and minimum temperature conditions existing at the root area. At some section along the blade, critical stress/temperature conditions for minimum rupture life will exist as shown schematically below.



The shear strength of the matrix at the critical temperature must be high enough to permit stress transfer along the fibers such that the required stress carrying capability is maintained.

All solid state processes require ease of diffusion bonding, and chemical composition may have significant effects on sintering of powders and on diffusion bonding of sheets. The tendency to form surface chromium carbide films, when both of these elements are present, had been identified as a problem in Ni alloy powder metallurgy and in diffusion bonding of sheet forms. Surface conditioning treatments may be required to aid diffusion bonding.

A list of potential matrix alloys is shown in Table I. Many of these alloys did not have a commercial designation and therefore were identified by letter.

Alloy A was the alloy developed by NASA and has a high tungsten Al and Ti additions for improved compatibility with the tungsten filaments. The high tungsten level potentially had a detrimental effect upon oxidation resistance

TABLE I

Potential Matrix Alloys for W. Fiber Reinforcement

<u>Alloy</u>	<u>Composition</u>	<u>Available Form</u>	<u>Compatibility</u>	<u>Oxidation Resistance at 1090°C</u>	<u>Creep Strength at 1090°C</u>
A	56Ni-25W-15Cr-2Ti-2Al	Powder	Excellent-Alloy developed by NASA as a compatible matrix.	Fair	Fair to good.
B	74-6Ni-20Cr-5Al-0.4Y	Powder-possibly sheet	Fair	Excellent	Poor.
12 C	Ni-12Cr-10Co-6.W-5Al 3Mo-3Ti-1.5Ta-0.3C	Powder or sheet. Commercially available sheet alloy - may be obtained with ultra fine grain size for superplasticity	Anticipated to be excellent - high refractory alloy content + Al and Ti.	Good	Fair to good.
D	Alloy B + Thoria Dispersion	Sheet	Fair	Excellent	Excellent.
E	78Ni-20Cr-2ThO ₂	Sheet-Commercially available	Poor - Would need reaction barrier.	Fair-Loss of Cr in high velocity gas stream	Excellent.
F	Ni-14Cr-6Al-4.5Mo 2.3Cb-0.1C	Powder	Fair to good	Fair	Good.
G	Ni-7.5Co-6.W-5Al 2Mo-1Ti-0.5Re-0.4Hf 0.13C	Powder	Good	Fair to good	Excellent.

and fabricability. Claddings or coatings could be used to extend oxidation life, however, and this alloy represented the best matrix alloy and provides the baseline for comparison with other potential matrix alloys. Alloy B was the second NASA selected alloy and was close to the optimum composition in terms of high temperature oxidation resistance. Fabricability was anticipated to be reasonably good and there was high possibility that this material would be available in sheet forms, thus extending the number of potential fabrication processes. Alloy D was the thoria dispersed modification of B and should have 1093°C (2000°F) creep strength equivalent to the currently available TD Ni-Cr, so that it would have the best combination of oxidation resistance and high temperature strength of any other Ni alloy.

Alloy C represented a commercially available wrought alloy which had been recently evaluated on a NASA-sponsored program⁽¹³⁾. The high refractory alloy addition and relatively high Al + Ti content was anticipated to result in an excellent combination of compatibility and oxidation resistance. This alloy could be procured in sheet form with an ultra fine grain size so that advantage of super-plastic deformation might be realized during fabrication of composites by the press diffusion bonding process. Reduced processing costs could therefore be achieved as a result of lower temperature and pressure requirements.

Alloy E was the commercially available sheet alloy TD Ni-Cr and was included because of its known excellent 1090°C (2000°F) creep strength properties. Poor compatibility and oxidation resistance (under dynamic conditions) would give this alloy a low rating for composite applications. Alloys F and G were representative of commercially available cast alloys for blades. G was the NASA-TRW VI-A composition which is one of the highest strength nickel alloys available and was recently fabricated by prealloyed powder techniques to produce a super-plastic condition by Freche et al⁽¹⁴⁾. With relatively high W and Mo and 5% Al, a good combination of compatibility, oxidation resistance and strength was anticipated.

With the exception of the TD materials, all alloys listed in Table I were expected to be readily available as prealloyed powders. The final selection included alloy A in powder form, as a baseline, Alloy B representing a highly oxidation resistant material potentially available in both wrought and powder forms, and alloy C which was representative of a high strength commercially available sheet material.

2.5 Fabrication Methods

Table II lists potential fabrication methods for Ni matrix composites. Processes 1-6 were considered as having greatest potential for producing high quality Ni-W composites in a cost effective manner and included powder and solid state (foil) diffusion bonding methods. Liquid phase processes were ruled out on the grounds of difficulty of preventing excessive reaction with relatively small diameter filaments. Deposition processes (including plasma spraying) produce poor quality matrices, are not cost effective, and require a secondary consolidation cycle. Extrusion processes have low processing cost potential. Little control over fiber distribution is obtainable, however,

Table II

Potential Fabrication Methods for Ni Matrix Composites

Process	Matrix Form	Consolidation Method	Characteristics
1. Slip casting	Powder	H.I.P.	Proven technique. Dimensional tolerance control may be difficult. Impact resistance of matrix may be poor.
2. Slip casting	"	Closed die pressing	Better dimensional tolerance - possible to incorporate forging operation into process to improve matrix impact properties.
3. TRW powder cloth process	"	H.I.P. or closed die pressing	Excellent control of fiber distribution - ease of fiber protection - applicable to small or large diameter fibers
4. TRW powder cloth monotape process	"	Die pressing	Ease of quality control - resulting monotapes useful for fabrication of many precision forms.
5. TRW powder cloth monotape process	"	Roll bonding	Low processing costs - potential automated production method.
6. Diffusion bonding	Sheet	H.I.P. or C.D.P.	High quality matrix - good impact properties. Ease of filament distribution - restricted to sheet alloys suitable for multi-ply or monotape configurations.
7. Roll diffusion bonding	"	Roll bonding	High quality matrix + low processing costs.
8. Liquid infiltration	Powder/melt	Molten phase	High temperatures - excessive fiber-matrix reaction.
9. Casting	"	"	High temperatures - fiber-matrix reaction - difficult to maintain filament alignment and distribution.
10. Plasma spraying	Powder	Powder + diffusion bonding	Generally produces low quality matrix - interstitial pickup. Probably low matrix impact resistance.
11. Extrusion	Powder	Coextrusion of matrix powder and fibers	Only applicable to fabrication of shapes of continuous cross section. Control of fiber distribution difficult on subsequent preform forging.
12. Deposition processes	Rod	Electro deposition or vapor deposition diffusion bonding	Problem of controlling matrix composition - applicable to simple compositions only. Process not very cost effective
13. Explosive bonding	Sheet	Explosive	
14. H.E.R.F.	Powder or sheet	High rate diffusion bonding	High rate bonding processes not well characterized with Ni alloys. Filament mechanical damage is a potential problem.

and it would not be possible to fabricate twisted airfoils directly. Therefore, the extruded preform would need a subsequent forging operation. Work at TRW on creep forging of composites showed that filament distributions were changed and problems of filament clustering can be encountered. It would also be difficult to ensure that complete fiber encasement was achieved, particularly at the ends of cut off pieces of bar. This process also lacks versatility in terms of hollow blade fabrication. The other processes were not sufficiently characterized to warrant investigation on process development programs.

It was concluded that the powder processes with low cost starting materials and foil/filament diffusion bonding processes, which produce the highest quality matrices, had the greatest potential for blade fabrication. The foil/filament method has been widely used to fabricate test panels and airfoil sections in Al and Ti matrix systems and basically the same procedures were used on this program to fabricate W/Ni composites using temperatures in the 1090°C (2000°F) range. The use of matrix in the form of pre-alloyed powders may represent important fabrication methods for Ni alloy composites and therefore are discussed separately.

2.5 Powder Processes

Prealloyed powder techniques have been used successfully for many years to fabricate ferrous metal components. More recently these techniques have been applied to the fabrication of superalloy parts in the aerospace industry. Inert gas atomization of molten alloy produces fine powder particles of uniform composition so that on subsequent powder consolidation a fine grained product free from macroscopic segregation is obtained. A greater range of alloy compositions is thus possible and savings in material costs and labor can be achieved, as a result of reduction or elimination of machining operations. The major potential problems are due to the possibility of high interstitial pickup during powder fabrication and subsequent consolidation and to the presence of residual porosity in the consolidated product. Both of these effects can have detrimental influence on ductility and impact properties.

The use of slip casting processes with hot gas isostatic pressing for the fabrication of tungsten/nickel composites is well documented in References 1 and 5. The major disadvantages to this process were difficulty of controlling fiber distribution and problems in producing complex blade shapes to close dimensional tolerances. A novel powder process for the fabrication of filamentary reinforced composites was developed at TRW. This is the powder cloth process in which the matrix powders are blended with a small quantity of organic binder (teflon) and warm rolled into high density, handleable sheets. During rolling, the teflon forms an interlocking network of fibers which holds the powder particles together. Sheets of matrix powder as thin as 0.0127 cm. can be readily produced and pre-collimated layers of filaments can be selectively positioned between layers of matrix for subsequent consolidation by hot press bonding or HIP.

The teflon and organic binder used to collimate the filaments are completely removed during the heat up cycle under dynamic vacuum. Excellent control of filament distribution and spacing can be achieved by use of filament mats and matrix layers.

2.7 Blade Fabrication Processes

A schematic flow diagram of monotape fabrication and use in blade fabrication is shown in Figure 6. The ease of quality control of monotapes has already been discussed. Good handleability, control over placement of reinforcement, ease of secondary forming to complex shapes (twist formability) and applicability to fabrication of simple and complex shapes are other advantages. Low temperature/pressure joining processes such as brazing and braze diffusion bonding may be used. Application to hollow blade fabrication is a potentially attractive feature of W/Ni monotapes.

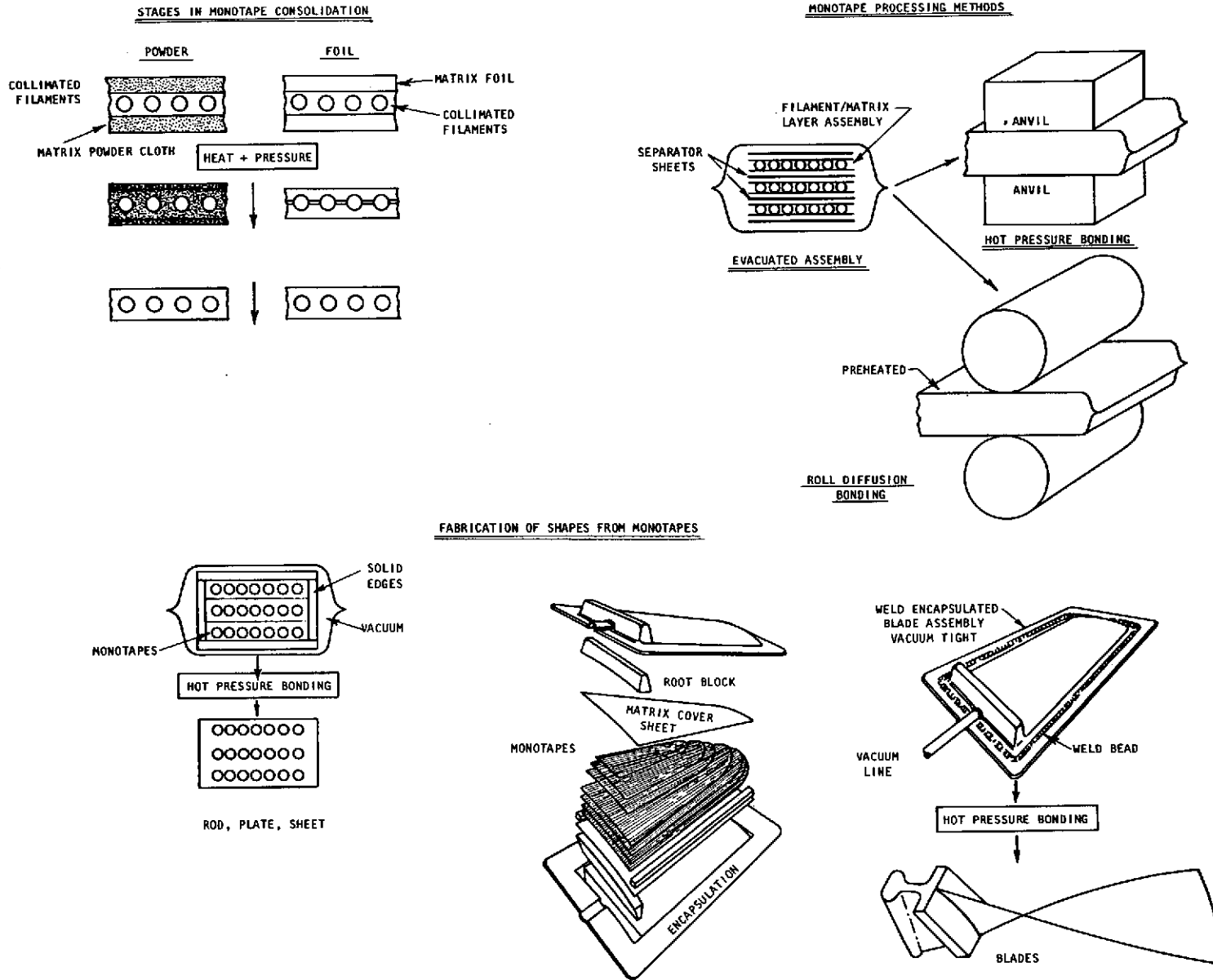

Figure 6. Fabrication and Applications of Composite Monotapes.

3.0 EXPERIMENTAL PROGRAM

The experimental activities are discussed in the following sections under the subheadings Material Procurement and Inspection, Evaluation of Processing Methods, Stress Rupture Specimen Fabrication, and Testing and Thermal Fatigue Specimen Fabrication.

3.1 Material Procurement and Inspection

Fibers

The reinforcing fiber used for all composites fabricated in Task I was 0.038 cm (0.015 in) diameter GE type 218 CS tungsten lamp filament wire. Published properties for this material are:

Melting point: 3400°C (6150°F)

Room temperature modulus: 3.44×10^5 MN/m² (50×10^6 psi)

1000-hour rupture stress at 1093°C (2000°F): 344 MN/m² (50 ksi)

Matrix Alloys

Important criteria on which the selection of matrix alloys was made included the following, ranked in approximate order of importance:

- chemical compatibility with tungsten filaments
- oxidation resistance
- fabricability
- strength at 870°C (1600°F) and 1093°C (2000°F)
- impact resistance and ductility
- ability to be diffusion bonded
- coatability
- cost

Based on a consideration of the above, available composition, and a desire to evaluate several potential fabrication methods, the following nickel-base alloy compositions were selected in the form indicated.

TABLE III

<u>Alloy</u>	<u>Nominal Composition</u>	<u>Form</u>
A	56Ni-25W-15Cr-2Ti-2Al	Powder
B	74.6Ni-20Cr-5Al-0.4Y	Powder
C	Ni-12Cr-10Co-6W-3Mo-1.5Ta-4.6Al-3Ti-0.3C	Sheet

The alloys A and B were vacuum induction melted by TRW Metals Division and cast into ingots. Conversion to powder was by Homogeneous Metals, Inc., using a soluble hydrogen gas technique. The actual atomization takes place in a vacuum chamber. The powders were collected and classified into the following size ranges:

TABLE IV

	<u>Percent of Total Powder Weight</u>	
	<u>Alloy A</u>	<u>Alloy B</u>
a. -20 to +100 mesh	33.0%	28.4%
b. -100 to +500 mesh	56.5%	46.5%
c. -325 to +500 mesh	8.7%	18.5%
d. -500 mesh	1.8%	6.7%

All powder handling and bottling was performed under a protective atmosphere.

Alloy C was procured from Universal-Cyclops in the form of sheet (0.036 cm and 0.051 cm) (0.014" and 0.020") and plate (0.318 cm) (0.125"). The vendor supplied analysis is shown in Table V.

TABLE V

Chemical Analysis of Alloy C 2-IDA

<u>Cr</u>	<u>W</u>	<u>Ta</u>	<u>Mo</u>	<u>Co</u>	<u>Al</u>	<u>Ti</u>	<u>Fe</u>	<u>B</u>	<u>Zr</u>	<u>C</u>	<u>Mn</u>	<u>Si</u>	<u>S</u>	<u>P</u>
.16	6.15	1.65	3.02	9.96	4.57	3.02	0.35	0.014	0.12	0.34	0.02	0.04	0.003	0.001

This material was processed by hot rolling in such a way that a very fine grain size was produced. Nickel alloys having an extremely fine grain size can have enhanced plasticity under the proper conditions of temperature and strain rate. Photomicrographs of the as-received (as not rolled) material are shown in Figure 7. The grain size of this 0.036 cm (0.014") sheet was in the range of 2 to 5 microns.

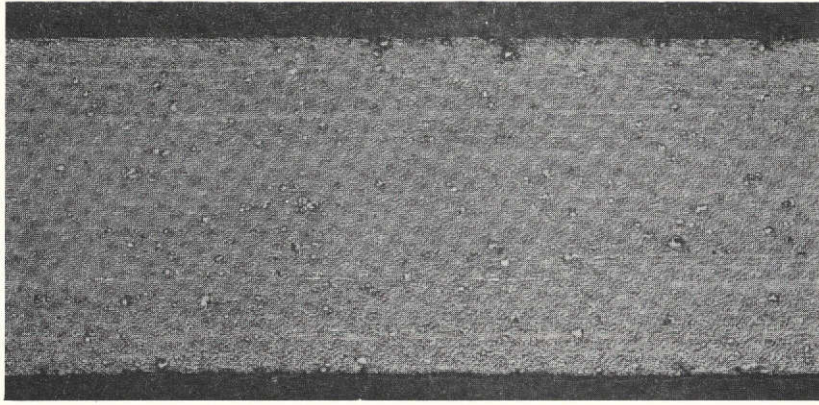

a. 100X

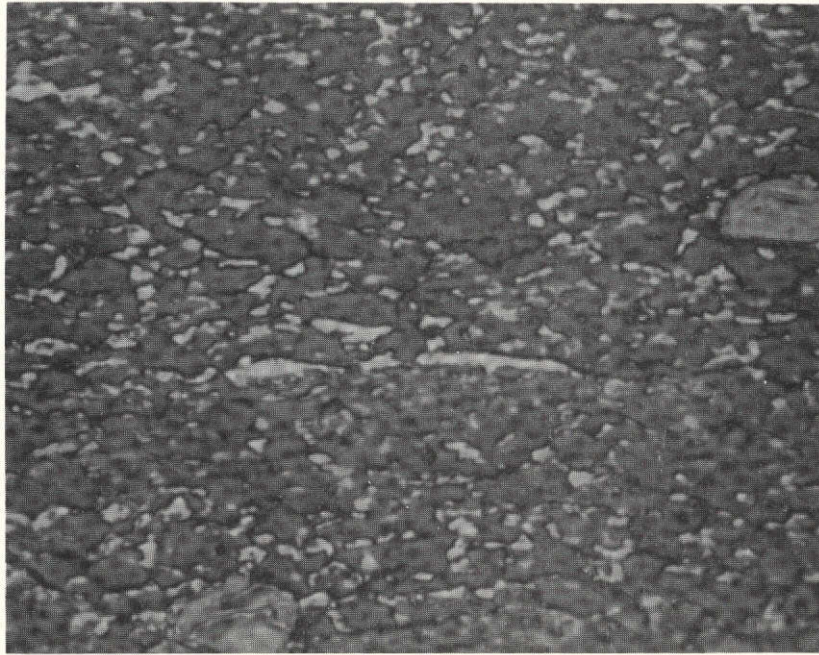

b. 2000X

Figure 7. Microstructure of Specially Processed Alloy C (2-1DA) (Nickel Alloy) Sheet. Note the fine grain size indicative of the potential for superplasticity.

3.2 Evaluation of Processing Methods

Three distinct fabrication techniques were evaluated as indicated by the flow chart shown in Figure 8. These methods are:

1. Slip casting - hot isostatic pressing
2. Powder cloth - filament mat bonding
3. Foil-filament mat diffusion bonding

It was the intent of Task I to evaluate these methods, partially optimize them and select one in combination with a suitable matrix alloy for further refinement in Task II.

3.2.1 NASA Slip Casting-Hot Isostatic Pressing

The NASA-Lewis developed slip casting and hot isostatic pressing technique for the production of tungsten fiber reinforced nickel alloy composites was used to produce specimens with Alloy A (Ni-25W-15Cr-2Al-2Ti). The method is capable of achieving good matrix consolidation and bonding between fiber and matrix without excursions into the liquid region which would greatly increase fiber matrix reactions. Furthermore, the bonding is achieved at 1093°C (2000°F), the potential use temperature of the composite. A schematic diagram of the method showing the important phases of processing is shown in Figure 9.

The slip was prepared by blending the powder into an aqueous solution of an ammonia salt of alginic acid (Marex). The composition of the metal slip was 8.98 wt/o distilled water and 0.12 wt/o Marex, the balance being metal powder. Powder in the size range of -325 to +500 mesh was used to prepare the slip; coarser powders having been found to be difficult to maintain in suspension while finer particles are difficult to obtain in the required purity. A significant deviation from the original NASA process was that the fiber reinforcement was restricted to a 0.207 cm (0.080 inch) diameter core within a 0.95 cm diameter specimen so that on subsequent machining of stress rupture specimens no tungsten fibers would be exposed. Because of this modification, the specimen fabrication required a two-stage slip cast and sinter operation. This procedure was more difficult than the NASA procedure and problems of incomplete powder fill of the stainless steel tubes were encountered. The procedure for the two stage casting method is illustrated in Figure 10. A glass rod coated with a fluorocarbon part agent was used to make the annular cavity and after partial sintering the W fibers were inserted along with additional slip. It was anticipated that specimens fabricated by press or roll diffusion bonding would have superior matrix properties by virtue of greater deformation and motion of particle interfaces. The H.I.P. specimens, therefore, were to serve mostly as baseline data.

The first batch of nine specimens was shipped to Industrial Materials Technology (IMT) where they were leak tested in helium prior to hot isostatic pressing. None of the sealed tubes showed evidence of leaks. The pressing cycle was 816°C (1500°F) for 1 hour at full pressure (argon gas, 137.9 MN/m²)

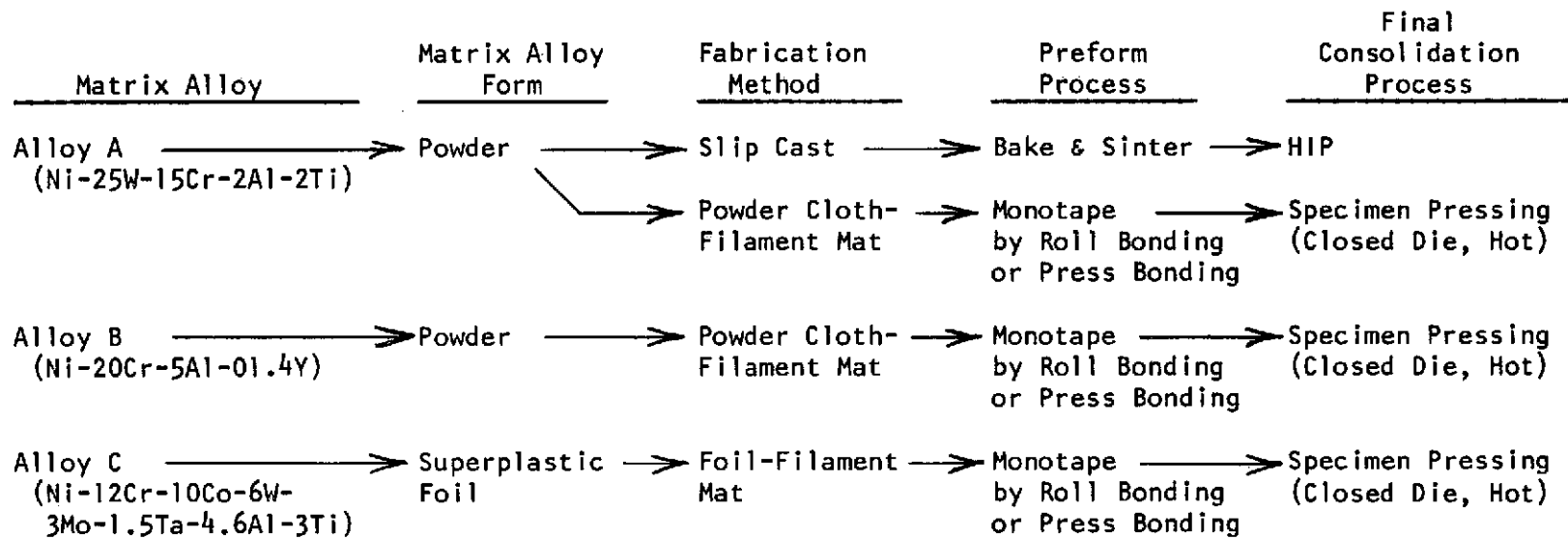

Figure 8. Flow Diagram showing Matrix Alloy-Fabrication Method Systems Evaluated in Task I.

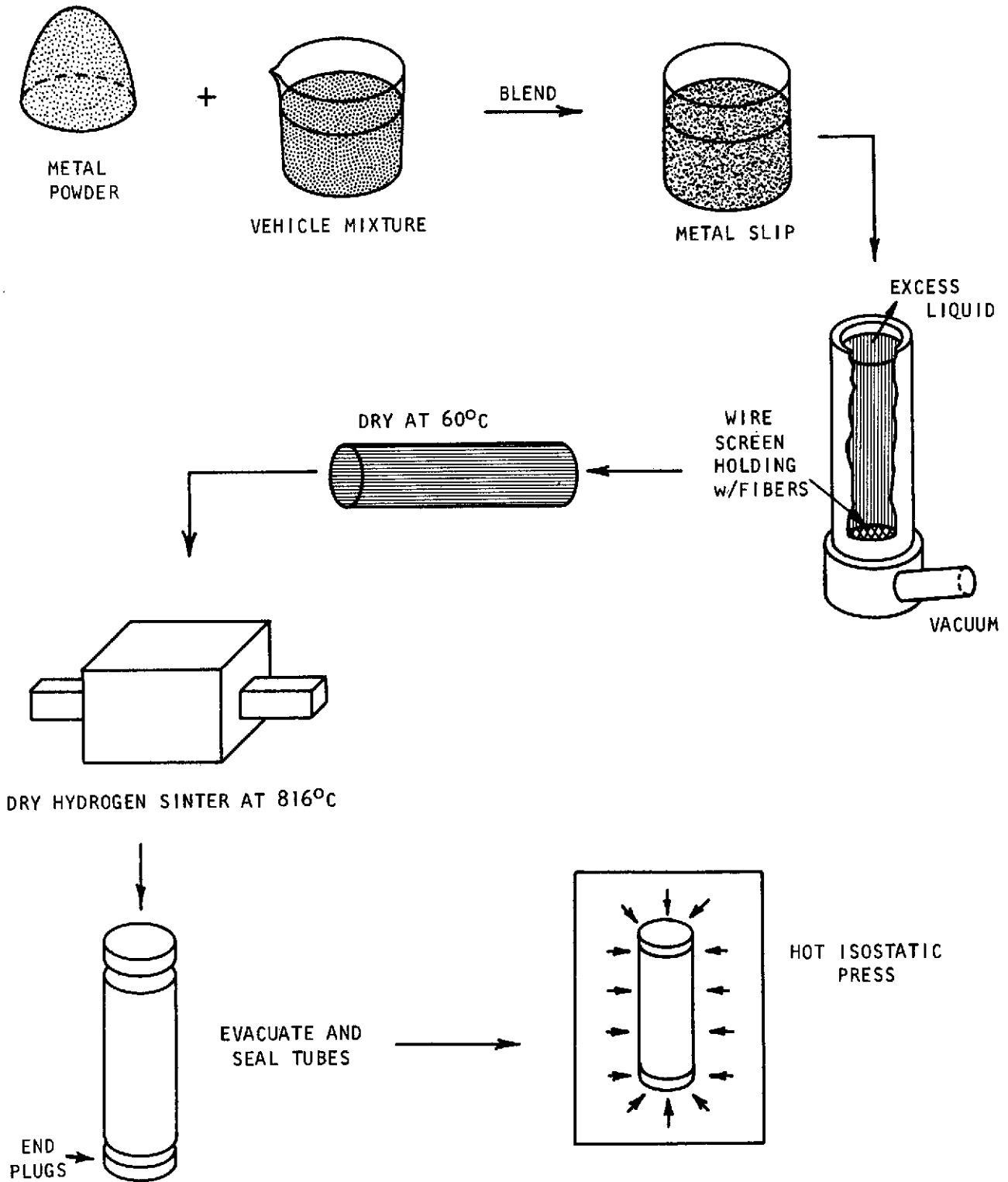
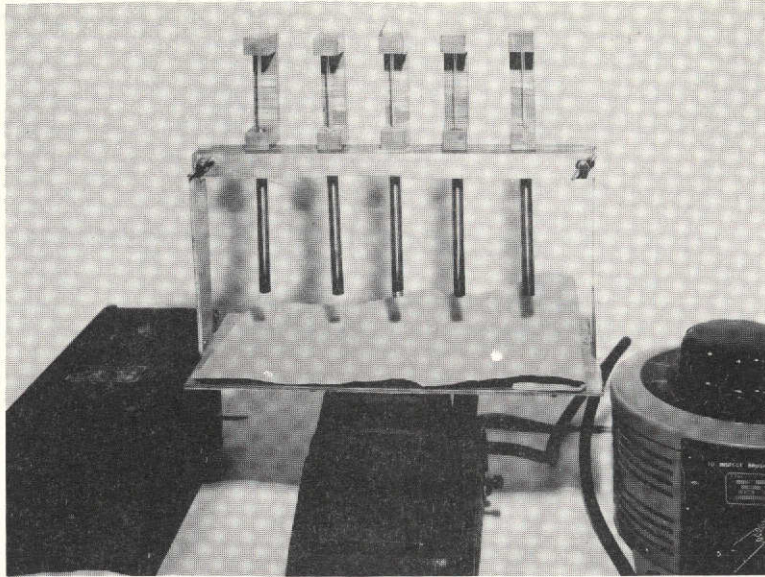
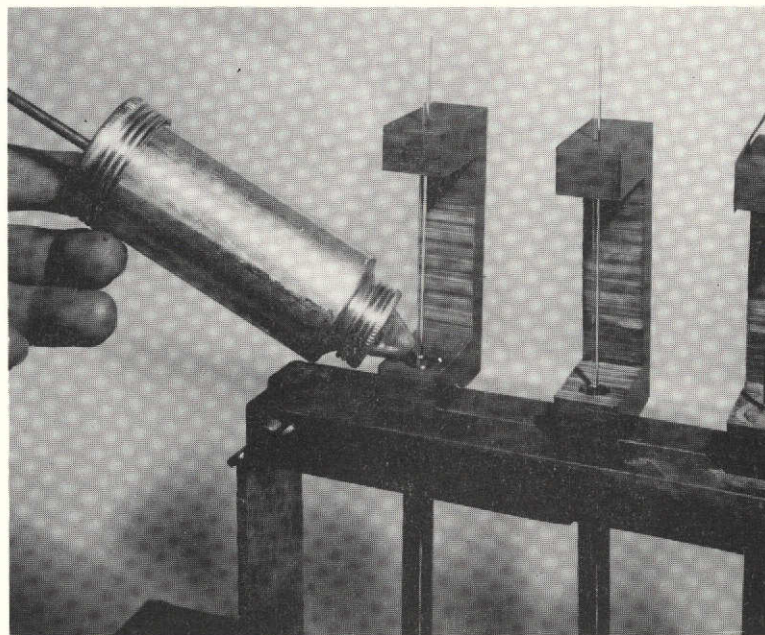

Figure 9. Flow Diagram of Slip Casting and Hot Isostatic Pressing Method to Produce W Fiber-Ni Alloy Matrix Composites.



a. Over-view showing vibrating table and tube holder.



b. Close-up showing fixture for holding glass rod cores. Method of slip addition is demonstrated.

Figure 10. Slip Casting Apparatus Used to Produce Tungsten Wire Reinforced Nickel Alloy Composites.

followed by 1093°C (2000°F) for 1 hour at 20 ksi (137.9 MN/m²). After receipt these specimens were subjected to preliminary evaluations. Most of the specimens had flattened ends and were bent and distorted, evidently due to insufficient powder fill.

The best specimens were straightened by hot swaging (preheated to 816°C in argon) and subsequently evaluated by X-ray radiography to determine filament distribution and whether filament breakage had occurred. These evaluations indicated that the filament distribution was poor and that it would not be possible to machine suitable stress rupture specimens for testing in air. It was subsequently decided at a program review meeting that analysis of this first batch of specimens would not be continued.

A second batch of 15 specimens was prepared using a modified bottom filling technique and a higher sintering temperature of 1093°C (2000°F) to produce a harder "shell" before placement of the tungsten fibers in the core. As indicated by weighing samples before and after sintering, a much improved powder fill was obtained. Figure 11 shows specimens assembled in a rack prior to evacuating and sealing in the electron beam welder.

To avoid the problem of bending during the HIP process, these specimens were packed into a 12.7 cm (5") length of heavy wall Inconel tubing with allowance for central location of a thermocouple. In order to minimize handling of these specimens, and since there were more samples than required for baseline evaluation or contracted for with IMT, it was decided that leak testing was unnecessary. This decision was based on the observation that no leaks were found in the first batch of specimens. The same hot isostatic pressing cycle was used for both batches.

The second batch of specimens was received from IMT and visual inspection revealed that six of these specimens were essentially unchanged in appearance, with no evidence of compaction, indicating that they had developed leaks. Most of the remaining specimens were quite straight and appeared to be well consolidated.

Following some encouraging results with the other advanced processing methods, it was decided to postpone further evaluations on these HIP specimens in favor of placing more effort on the more promising fabricating methods.

3.2.2 Diffusion Bonding Processes

The diffusion bonding processes, using matrix in the form of rolled foil or powder cloth, are schematically illustrated in Figure 12. Precollimated filaments are sandwiched between layers of matrix in the form of rolled sheet or powder cloth, and the matrix is made to extrude between fibers by a hot pressing or hot rolling operation. In the ideal case, fiber/matrix and matrix/matrix metallurgical bonding is achieved while preserving uniform fiber distribution and eliminating any voids.

The powder cloth process and results of the preliminary process evaluations are described in the following paragraphs.

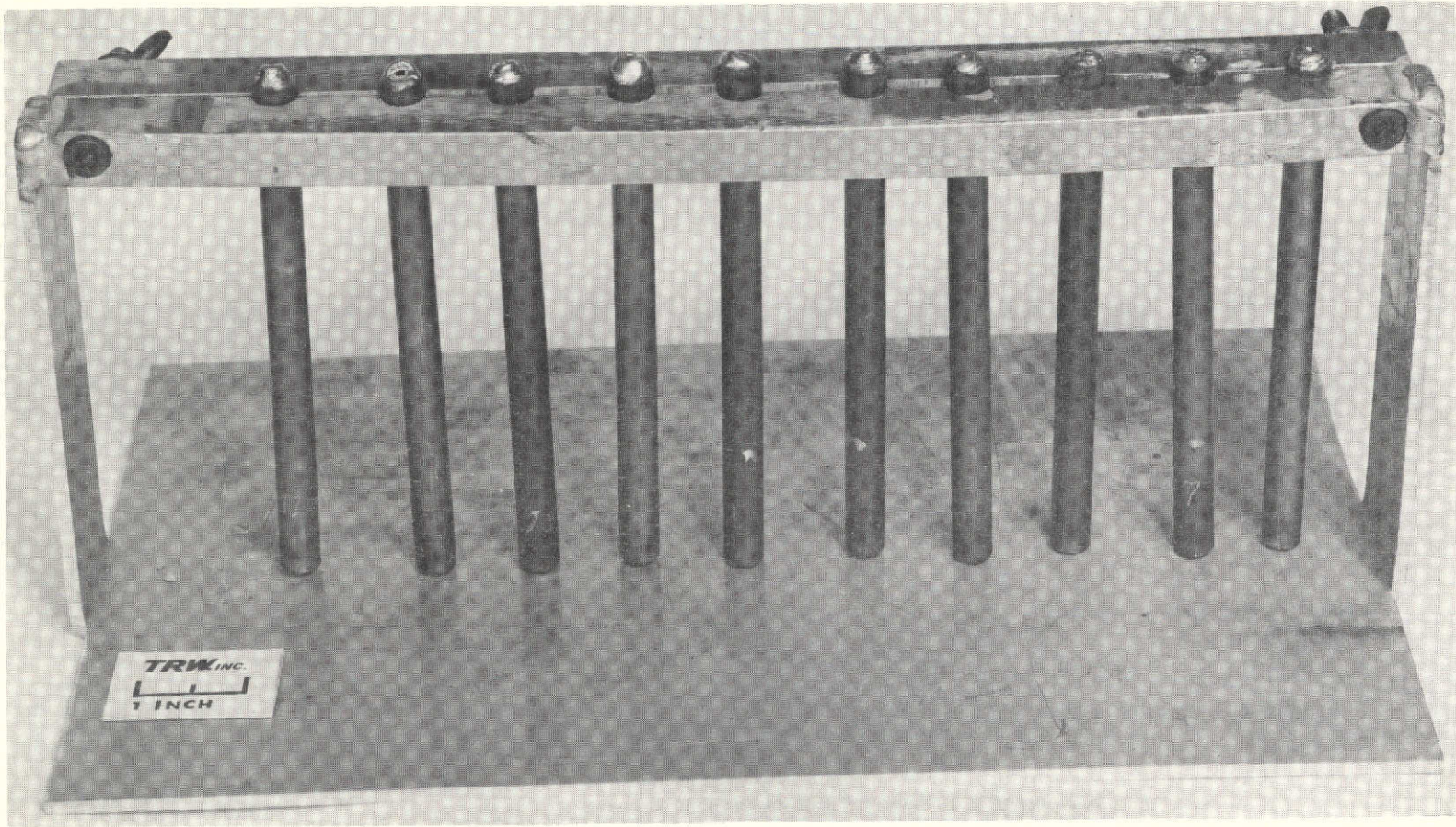

Figure 11. Batch 2 Slip Cast Specimens Prior to Evacuation and Sealing by Electron Beam Welding.

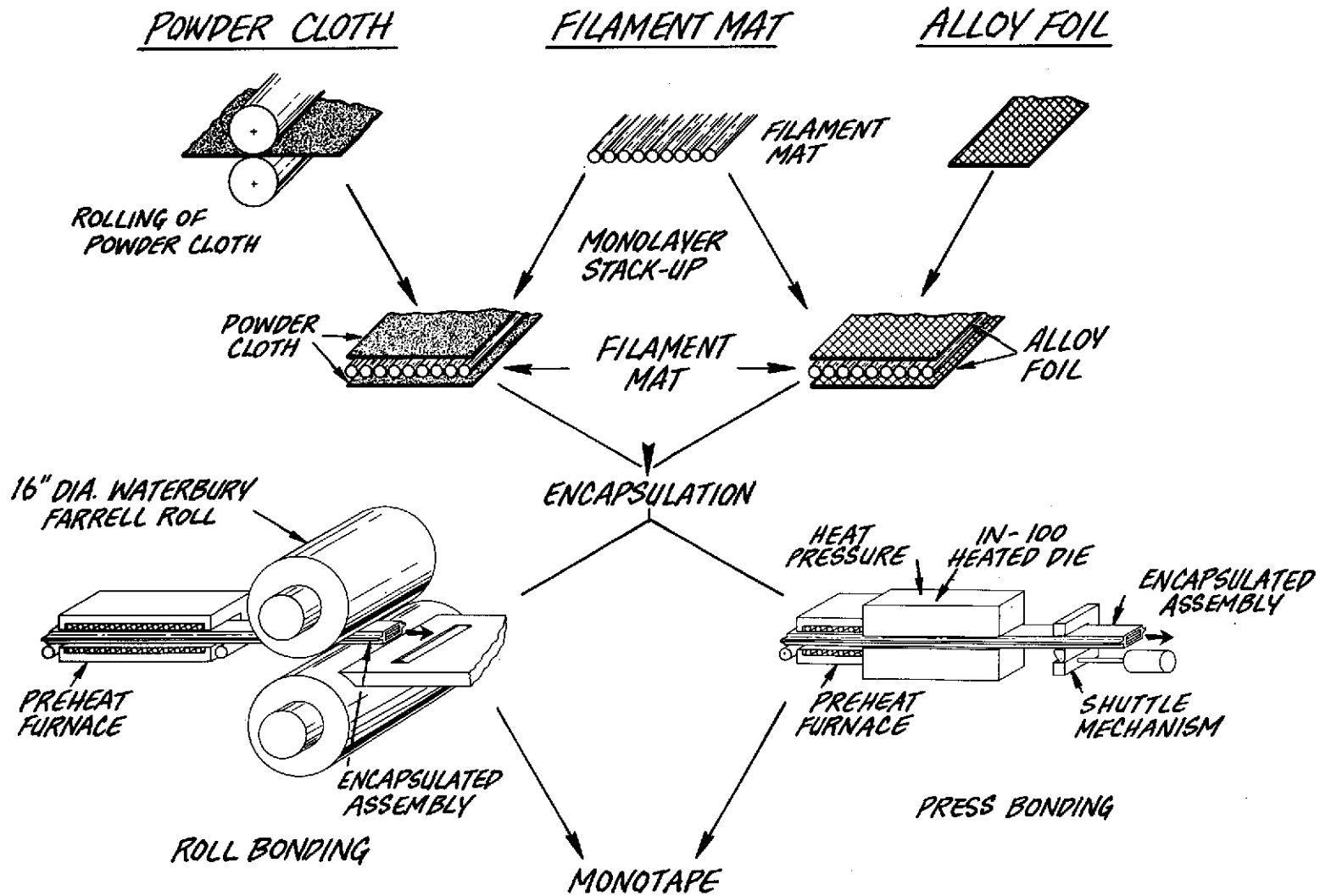

Figure 12. Flow Diagram of Diffusion Bonding Techniques for the Manufacture of W Fiber-Ni Alloy Matrix Monotapes.

Powder Cloth Process

This technique is a modification of the more familiar matrix foil-filament mat process used by TRW to produce aluminum-boron and titanium-Borsic composites. The technique of converting loose powder into a handleable powder cloth by using a suitable plasticizer such as teflon was developed at TRW for the production of porous nickel products. It had been recently applied to the production of tungsten/nickel alloy composites and monotape.

A schematic representation of the process as applied to the production of monotapes is shown in Figure 12 (left). The process begins with powder of the same quality as that utilized by the slip casting process. The loose powder is blended with a small quantity of liquid teflon to form a viscous mass. The mixture is then warm rolled to a cloth of the desired thickness. Monotapes are produced by cutting powder cloth and collimated tungsten filament mats to the desired size, stacking the filament mat between two layers of powder cloth, encapsulating in an evacuated retort, and consolidating by rolling or hot pressing. The volume percent of filamentary reinforcement in the core is determined in the manufacture of the monotapes. Filament spacing and powder cloth thickness are adjusted to achieve the desired volume percentage. Test specimens or hardware may be easily fabricated from consolidated and inspected monotape by diffusion bonding the desired number of monotape plies.

Preliminary Press Diffusion Bonding Evaluations

Included under the general heading of press diffusion bonding processes are the TRW powder cloth process and the foil-filament process. Alloy A (Ni-25W-15Cr-2Al-2Ti) and Alloy B (Ni-20Cr-5Al-0.4Y) were used in the powder cloth form, and Alloy C (2-1DA composition) was in the fine grained sheet form. Details of the powder cloth fabrication are described above. In the subsequent diffusion bonding process, layers of collimated filaments are sandwiched between thin sheets (powder cloth or foil) of matrix and the matrix is caused to flow between the filaments by the application of heat and pressure. It was anticipated that the initial stages of consolidation (matrix extrusion between fibers) would occur more rapidly with the matrix in the form of powder cloth than with the fully dense foil matrix. The 2-1DA foil was procured to a very fine grain size specification in order to realize potential benefit from micrograin superplasticity effects. The hot pressing procedure, however, resulted in a relatively short time for consolidation (high strain rate) so that superplastic behavior did not occur.

Powder cloths of the two matrix alloy powders were prepared by warm rolling using a teflon binder. Both alloys were rolled to thicknesses of 0.025 to 0.031 cm (0.010 to 0.012 in) yielding densities of 50 to 60% of theoretical. The 0.038 cm (0.015 in) tungsten wire was collimated by drum winding methods using a polystyrene base fugitive binder. Powder cloths (Alloys A and B), alloy foil (Alloy C), and filament mats were cut to size, approximately 10.2 to 2.54 cm (4 x 1 in). The alloy A powder cloth and tungsten filament mat shown in Figure 13 are typical samples. One monotape was produced by stacking the filament mat between two pieces of powder cloth (or foil) and bonding the assembly. For the preliminary press bonding trials, monotapes were

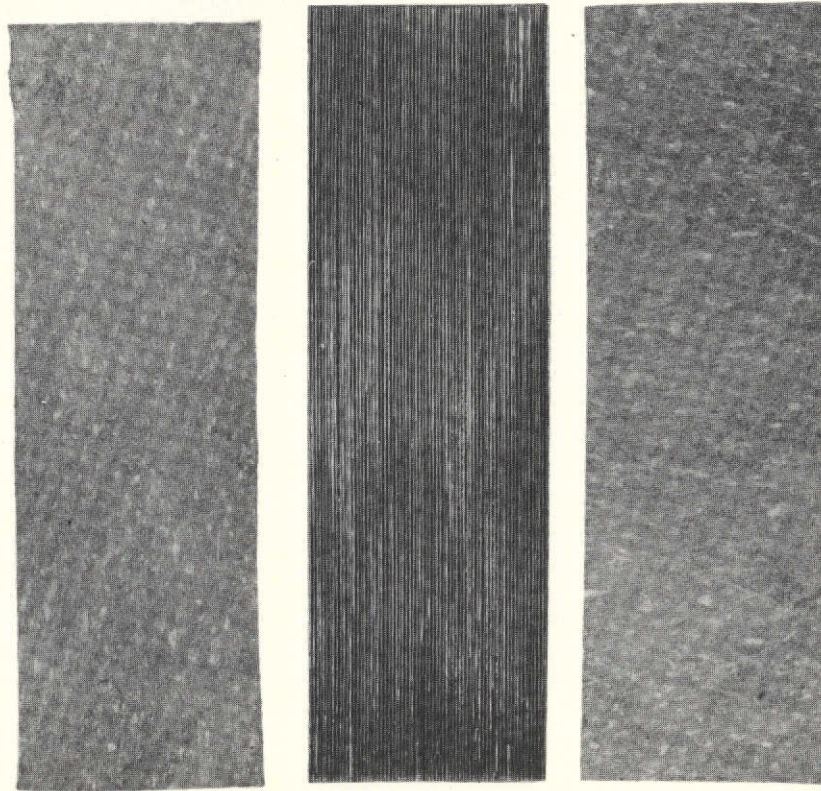

Figure 13. Typical Samples of Powder Cloth (NASA Alloy, Ni-25W-5Cr-2Al-2Ti) and Tungsten Filament Mat Ready for Stack-up and Press Bonding to Produce Monotape.

prepared from all three matrix alloys in a single pressing package. Molybdenum separators (0.025 cm-0.010 in) were placed between the different matrix alloy layers. B-1900 nickel alloy plates were used as dies. This entire package was placed within a stainless steel retort for pressing.

Evacuation of the can and removal of volatile decomposition products of the polystyrene and teflon binders was performed at low temperatures up to 540°C (1000°F). A preloading of approximately 34.4 MN/m² (5 ksi) was imposed during the preheating and evacuation phase in order to "set" the fibers in the matrix, thus preventing a loss of filament alignment. Following evacuation the retort was heated to 1093°C (2000°F) in a furnace. The heat-up time and time at temperature was kept as short as possible to minimize reactivity between the matrix and the tungsten fibers.

The IN 100 pressing dies were heated to 870 to 930°C (1600 to 1700°F). During the pressing cycle the retort cooled to the die temperature. However, most if not all of the consolidation was accomplished during the initial high temperature portion of the cycle making this essentially a hot forging process.

In these initial experiments complete consolidation was not achieved with any of the three matrix systems. Process refinements included changes in retort design, the use of higher strength die materials, the use of a dry hydrogen atmosphere, and variations in processing parameters. Parameters investigated were 1093-1225°C preheat temperatures, 103.2-245.8 MN/m² consolidation pressures and pressing times of 10-30 minutes. Following these iterative procedures, temperature (pre-heat temperature)/pressure/time requirements were established for successful consolidation of the three matrix systems. Additionally, unreinforced matrix specimens were fabricated for the subsequent fabrication of stress rupture and thermal fatigue specimens. Die problems were continually experienced during this period as the pressure/temperature conditions were increased beyond predicted levels. TZM material was substituted for the previously selected B-1900 and at a later stage a channel die configuration was found to be necessary to restrict filament spreading.

Examples of monotapes produced in these preliminary evaluations are shown in cross section in Figures 14 to 16. Encouraging observations were the minimal amounts of fiber/matrix reaction and the indications of more heavily worked matrix compared to that produced in the HIP process. As noted above, the use of TZM channel die configuration was shown to reduce filament spreading.

3.2.3 Roll Bonding Evaluations

Advantages of the roll bonding process are potentially low cost and extensive matrix deformation which should result in relatively high matrix ductility. A fairly extensive series of roll bonding feasibility studies was performed.

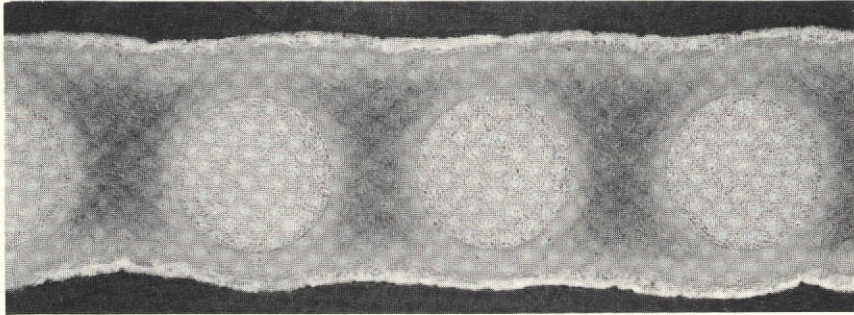

1175°C pre-heat temperature
227.7 MN/m² pressure
10 min pressing cycle

50X

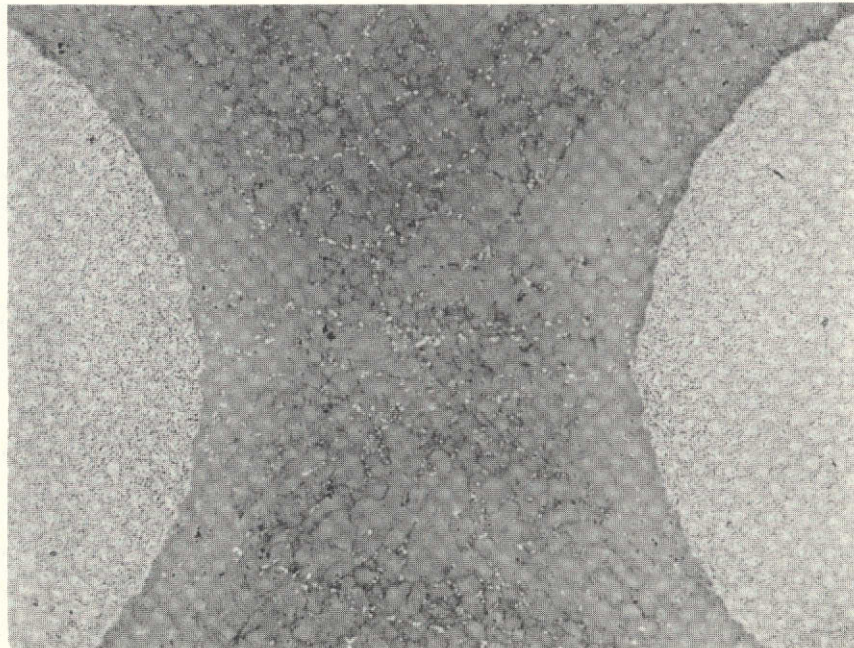

250X

Figure 14. Fully Consolidated Monotape Fabricated from 20 Cr Powder Cloth Alloy Matrix.

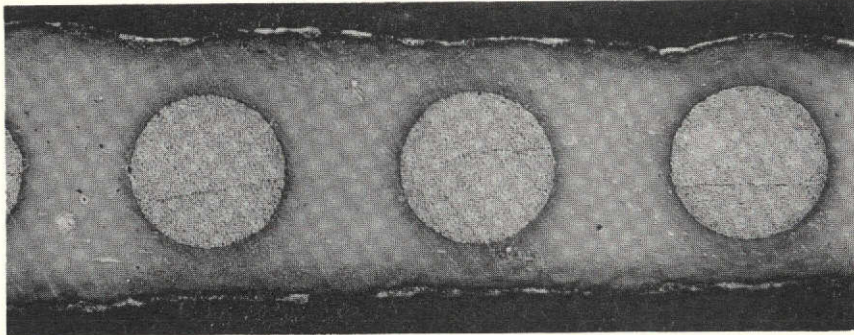

1175°C pre-heat temperature
227.7 MN/m² pressure
10 min pressing cycle

50X

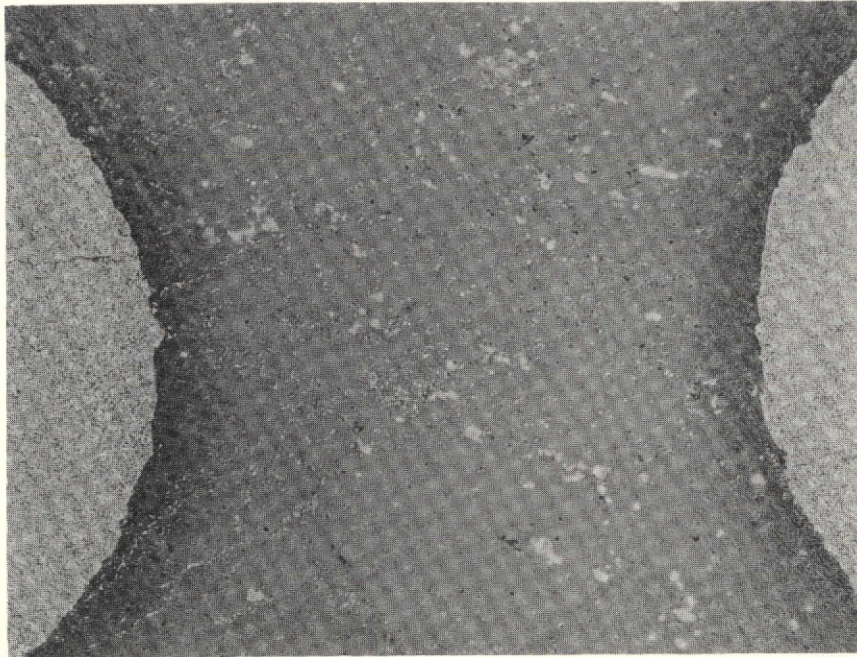

250X

Figure 15. Fully Consolidated Monotape Fabricated from 25W Powder Cloth Alloy Matrix.

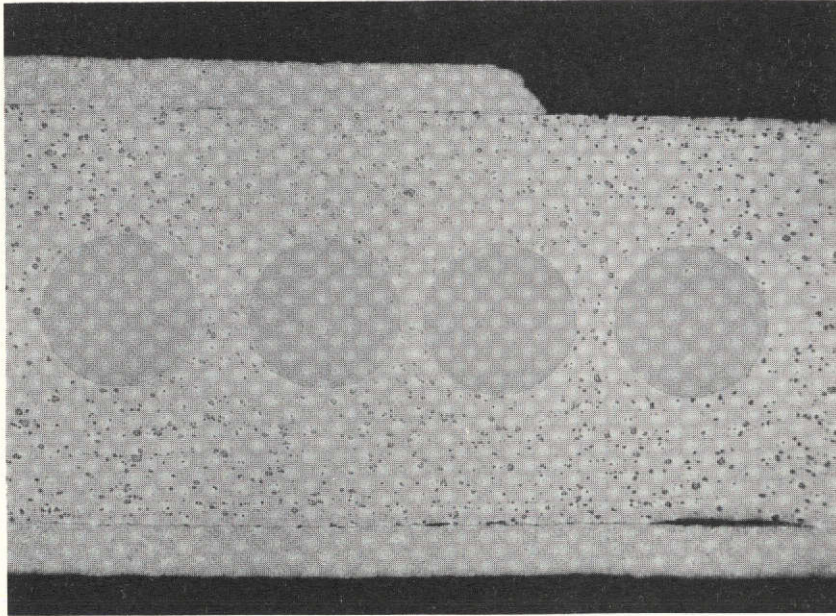

a. Acceptable filament spacing - fully bonded.

50X

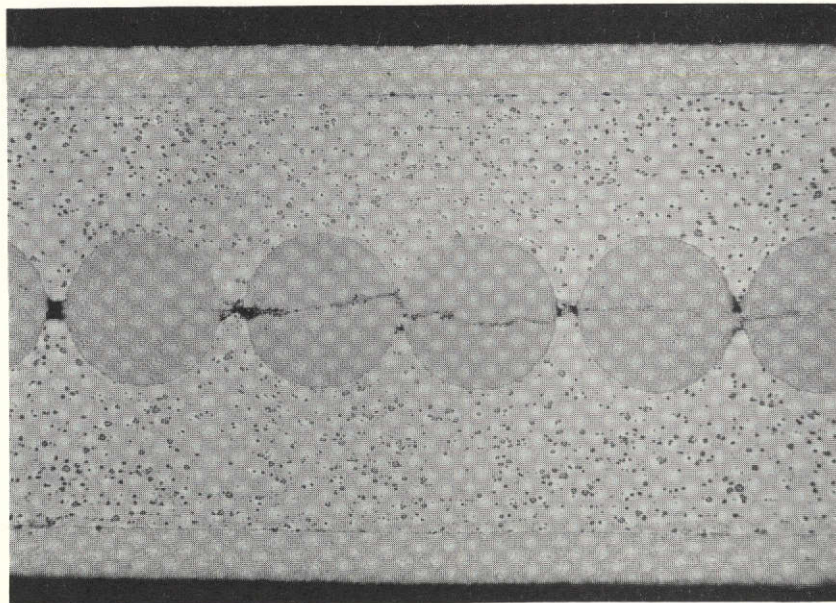

b. Filament clustering - not fully bonded.

50X

Figure 16. Cross Sections of W-2-1DA Composite Monotape.

Previous investigations at TRW had identified a number of problem areas. These were:

1) Slow heating

Long heating times in the preheat furnace, caused by the poor thermal contact of materials in the stack-up and also by the presence of the asbestos insulation, must be avoided to minimize oxidation of the powder alloys.

2) Rapid cooling

Heat losses from the relatively thin stack were extremely rapid both during transfer from furnace to rolls and during rolling.

3) Filament spacing control

It was difficult to apply a substantial clamping load to maintain alignment.

4) Breakdown of asbestos insulation

The organic binder in the asbestos burnt off during preheating, leaving the refractory fibers loose. Two problems resulted: the insulating qualities of the asbestos were reduced and movement of the insulation introduced a certain amount of non-uniformity in rolling deformation.

A novel approach to the solution of these problems was conceived and investigated. Briefly, it consisted of welding slightly dished sheets of stainless steel, along the entire length of the encapsulated monotape package. These were designed to apply a clamping load during heat-up due to the existing temperature gradient. On removal of the package from the furnace, the welded sheets would pull away from the encapsulation can, acting effectively as a radiation shield, thus eliminating the need for asbestos insulation.

The adopted procedure was as follows:

1) Assemble the Alloy A and B powder cloth and the one Alloy C foil unconsolidated monotapes inside a flattened stainless steel tube (encapsulator). Molybdenum 0.0127 cm (0.005") separators were used between each filament/matrix sandwich. Dimensions of the assemblies were approximately 1.27 cm x 15.2 cm (1/2" x 6"). Three reduction steps were achieved in a single pack by using extra thicknesses of Mo.

2) Heat assembly to about 480°C (900°F) to remove volatile constituents (polystyrene, teflon) while maintaining a dynamic vacuum.

3) Move assembly to pre-heat furnace while still maintaining a dynamic vacuum.

4) Close the vacuum valve and carry out rolling at a speed of 3.3 cm/sec (1.3 inch/sec). The roll gap was pre-set based on calculations of the theoretical consolidated thickness.

In the first run incomplete consolidation was achieved in all three specimens and the monolayer with 2-IDA matrix foils separated due to residual thermal stresses. Investigation showed that the tungsten filaments split in half indicating incomplete matrix-matrix bonding between fibers. In the second run a higher pre-heat temperature 1155°C (2135°F) instead of 1120°C (2050°F) and smaller roll gap were used. Otherwise, the procedure was essentially the same as in run Number 1.

Both powder cloth specimens were well consolidated along the 15.24 cm length. Figure 17 shows representative cross sections from the Ni-20Cr-5Al-04Y and Ni-25W-15Cr-2Al-2Ti alloy specimens. (For conciseness these alloys will be subsequently referred to as the 20 Cr and 25 W alloys, respectively.) A slightly corrugated surface was obtained due to the fact that the Mo separator sheets were relatively weak at the rolling temperature. High strength separator materials (TZM, W) would minimize this effect. It was observed that greater deformation of the W filaments occurred with the stronger 25W alloy matrix. Good interparticle bonding in the matrix appeared to have occurred but the degree of matrix deformation was greater in the 20 Cr alloy. The greatest problem was that of filament spreading so that a relatively low volume fraction reinforcement (<50%) was achieved even after matrix removal by etching. Full consolidation was not achieved in the system with 2-IDA foil matrix using these parameters.

Based on these data and the data obtained on the press diffusion bonding studies (discussed in the following paragraphs), it was decided, at the first program review meeting, to use the more fully developed press diffusion bonding process for the remainder of the program. It was important to observe, however, that feasibility of the roll bonding process had been demonstrated by these investigations, but the process required further refinements which could not be developed within the scope of the current program.

3.3 Stress Rupture Specimen Fabrication and Testing

It was the objective, in this phase of the program, to evaluate the stress rupture properties of Ni/W composites fabricated from diffusion bonded monotapes and to compare these data with the baseline data generated in the NASA work. Additional refinement to the processing techniques were required in order to obtain test specimens of acceptable quality. The preliminary stress rupture evaluations were performed at 1090°C (2000°F) in air using a specimen in which the tungsten fibers were completely encased by the matrix alloy.

3.3.1 Test Specimen Fabrication

The required test specimen geometry is shown in Figure 18. The composite core was intended to be 0.203 cm diameter or square, with a minimum of .051 cm unreinforced protective matrix "cladding" and with a fiber packing density of approximately 40 volume percent. Using preconsolidated monotapes as "building blocks" made it easier to fabricate specimens with a square section. This corresponded to 4 x 4 filament array and monotape specimens with filaments in groups of four were fabricated. Radiography was used to

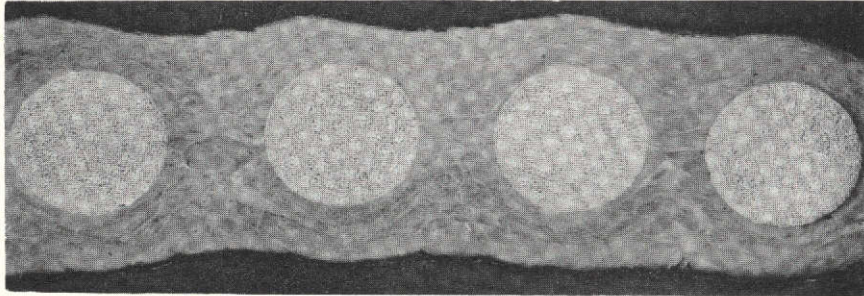

a. 20 Cr alloy matrix

50X

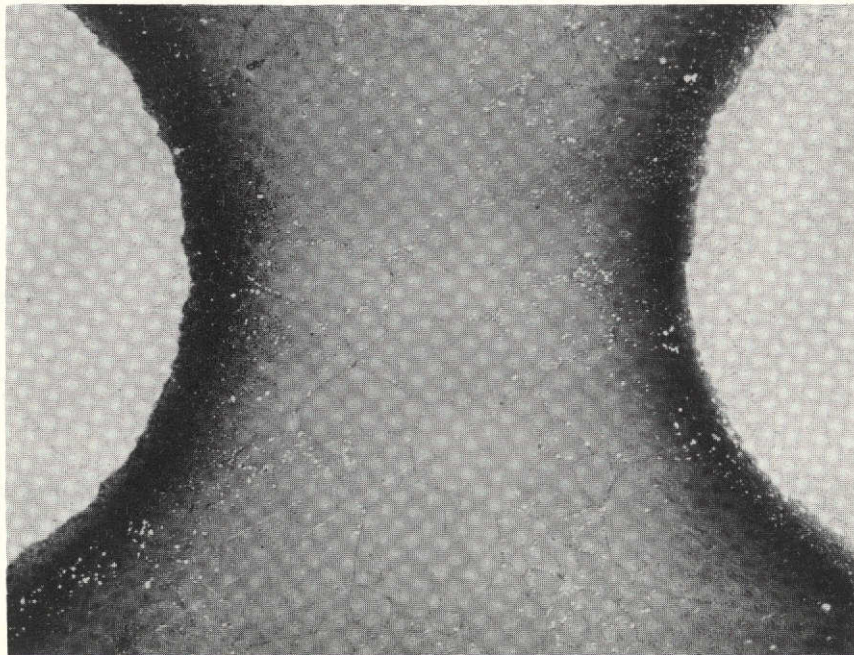

b. 25W alloy matrix

250X

Figure 17. Cross Sections of Roll Bonded W-Ni Alloy Monotapes Fabricated by the Powder Cloth Matrix Technique.

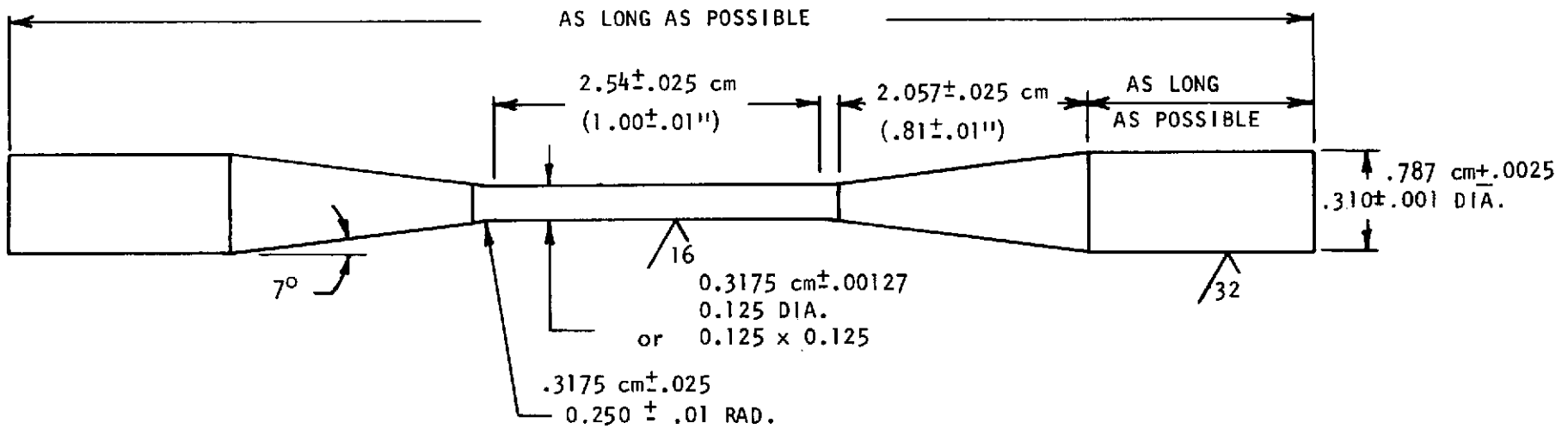

NOTE:

1. ALL DIAMETERS TO BE CONCENTRIC WITHIN .0005 F.I.R.

Figure 18. Creep and Stress Rupture Specimen Geometry.

determine filament alignment and distribution and to select suitable composite strips. Figure 19 shows typical X-ray radiographs of monotape panels from which acceptable monotape strips could be identified and machined.

The composite core strips were assembled in slotted superalloy frames as illustrated in Figure 20 to make the stress rupture specimen panels shown schematically in Figure 21. Although the picture frames and covers were fabricated out of available Alloy C sheet materials, the composite core was designed so that on machining the gage section only the particular matrix alloy of the composite system being investigated would be exposed to the test environment.

Following the secondary press diffusion bonding operation, a maximum of four stress rupture specimens were machined out of each panel in accordance with the specifications in Figure 18, and one blank was used for metallographic evaluations. Radiography was used extensively to identify defects such as delaminations, etc., and to locate the exact center of the core for machining purposes. Examples of radiographs of stress rupture specimen blanks are shown in Figure 22. In this particular photograph the tungsten fiber layers can be clearly seen and defects such as partial delaminations near the specimen ends and voids at the ends of the composite cores can be identified.

3.3.2 Stress Rupture Testing

Test specimens were machined from the specimen blanks to the specification shown in Figure 18 by grinding. There was a tendency for some specimens to delaminate during machining, particularly specimens from the edges of the panels. This was identified as a problem of inadequate bonding of monotapes and cladding during the secondary fabrication operation. In other cases poor filament distribution along the gage section resulted in exposed damaged filaments. Since processing methods were still in a stage of development, the data generated on these specimens should be regarded as preliminary.

Tests were performed at 1090°C (2000°F) in air using standard stress rupture test fixtures. Shoulder loading type grips were used with taper inserts of cast Mar-M-302 alloy. The estimated temperature at the grip location, based on thermocouple readings about 0.5 cm from the grips, was within 27°C (50°F) of that at the gage section. Problems of welding of the grip inserts into the grip holders were experienced, but they were solved by applying a nickel aluminide coating to the contacting surfaces.

Stress rupture data for composites with the 20 Cr and 25 W matrices are shown in Figure 23. The fiber stress levels shown are based on a fully relaxed matrix. Composites with 20 Cr alloy matrix apparently had higher stress rupture strength. However, delamination effects and fiber misalignment may have been more of a problem with the stronger 25 W matrix components. Some failures occurred due to oxidation of exposed fibers.

The data for the 20 Cr matrix composites indicate very efficient strength utilization of the fibers since the experimentally determined stress rupture curve for 218 CS tungsten (5) is in direct agreement with the data points obtained from the composites. In this respect the fiber strength utilization for the 20 Cr matrix composite was more efficient than in the case of W-2 ThO₂

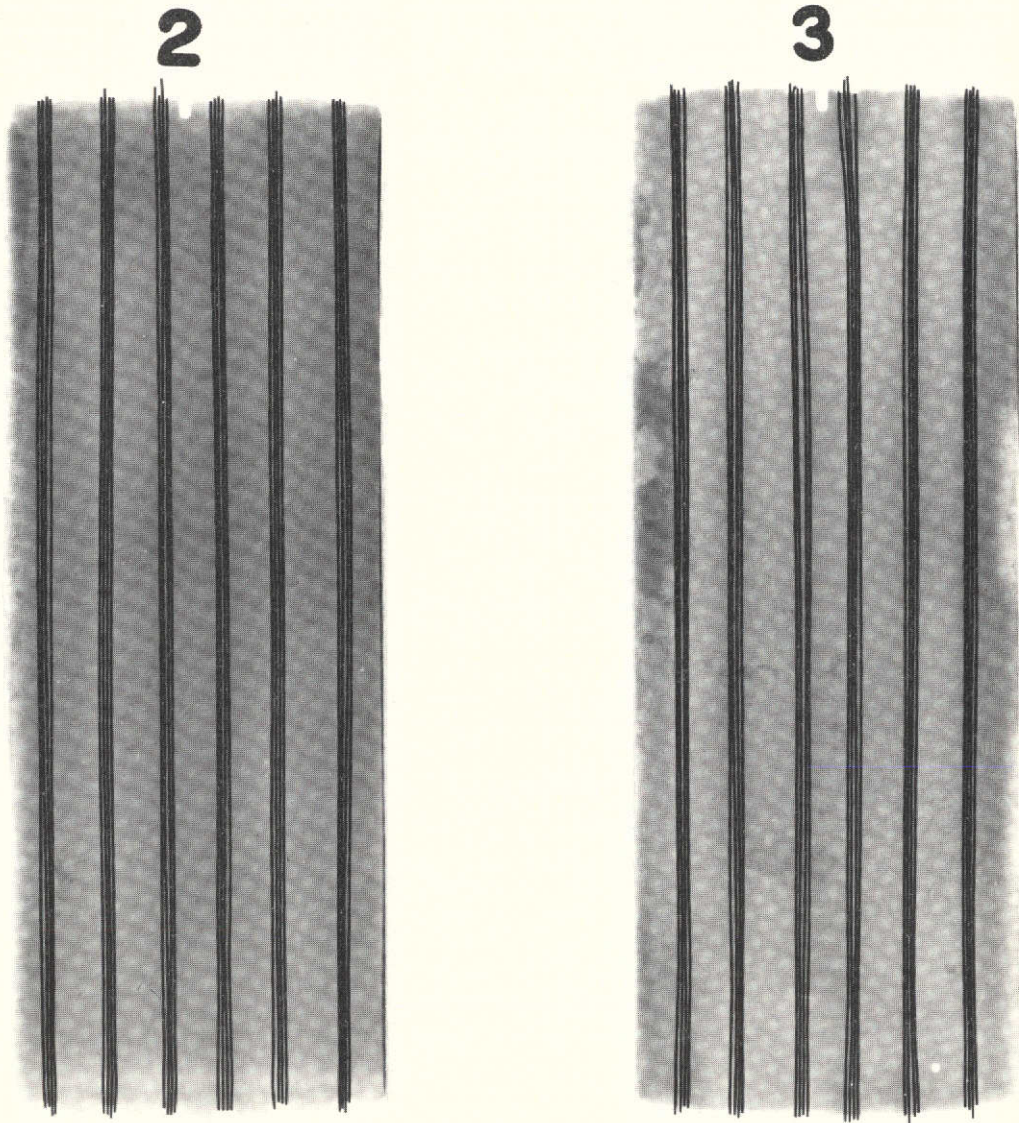

Figure 19. X-Ray Radiographs of W-Superalloy Monotape Panels.

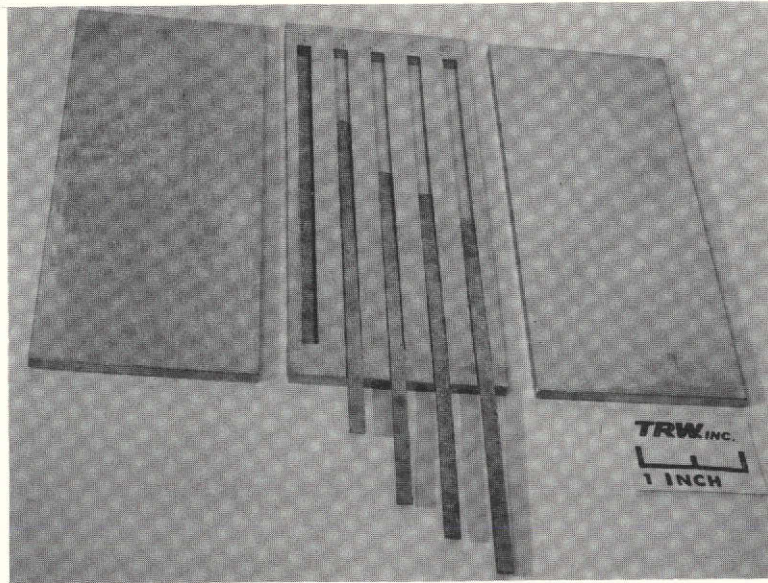

Figure 20. Monotape Assembly Procedure for Fabrication of Stress-Rupture Specimen Panels.

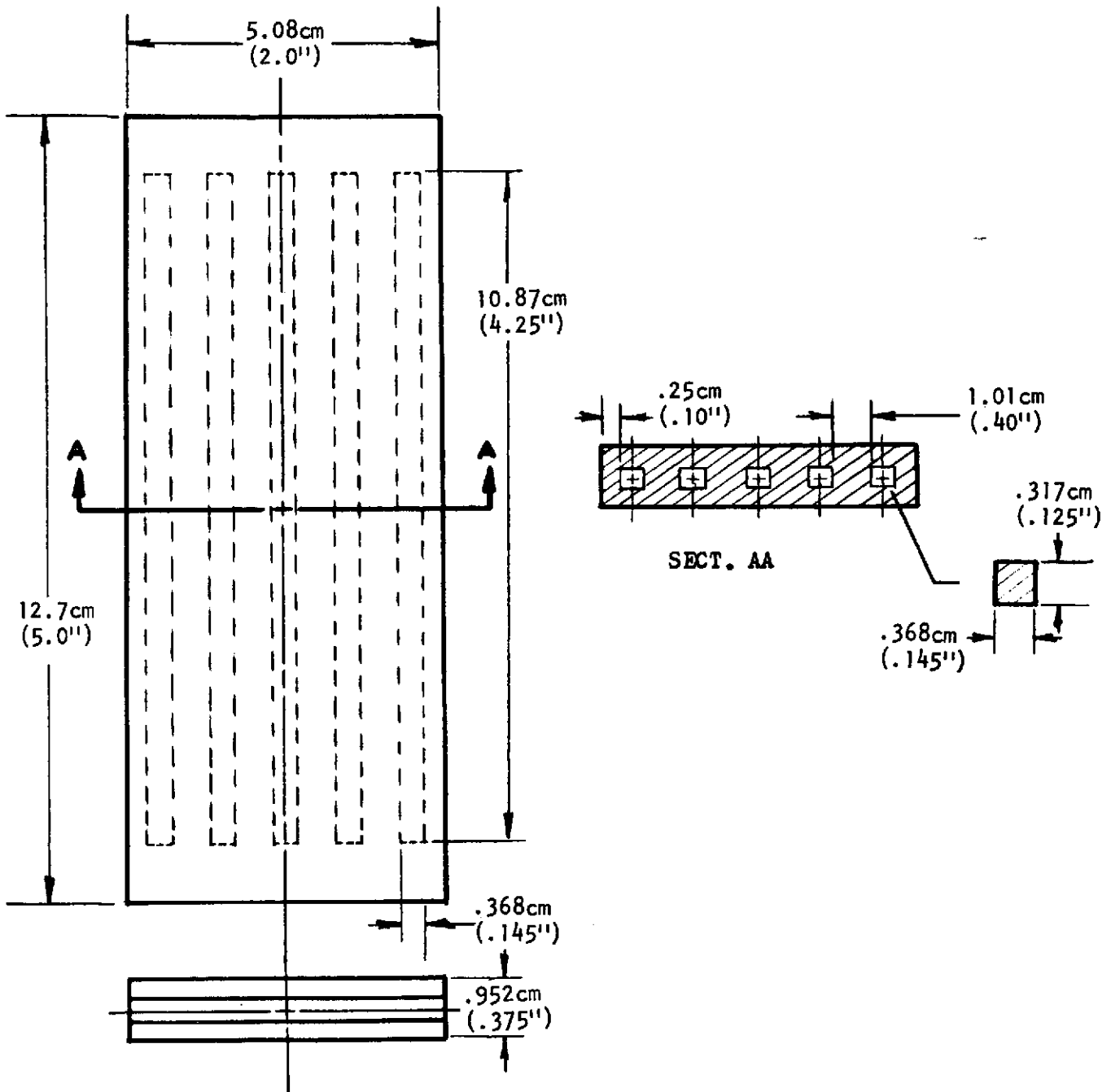

Figure 21. Stress Rupture Specimen Panel Design.

NASA P18

90°

1 2 3 4

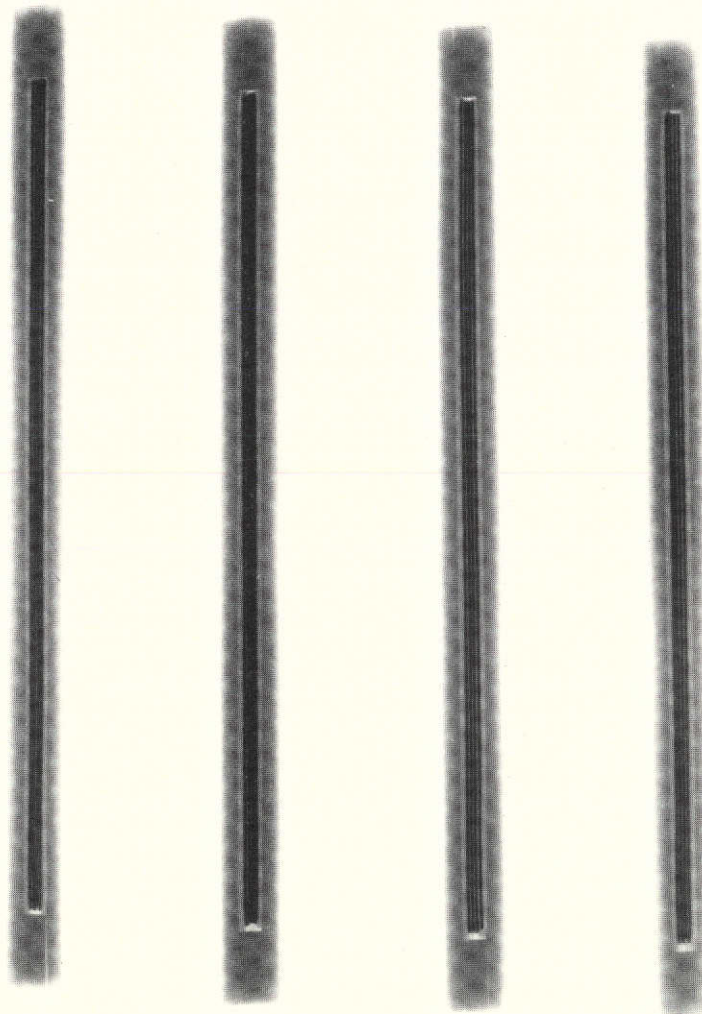

Figure 22. X-Ray Radiographs of W/20Cr Alloy Stress Rupture Specimen Blanks.

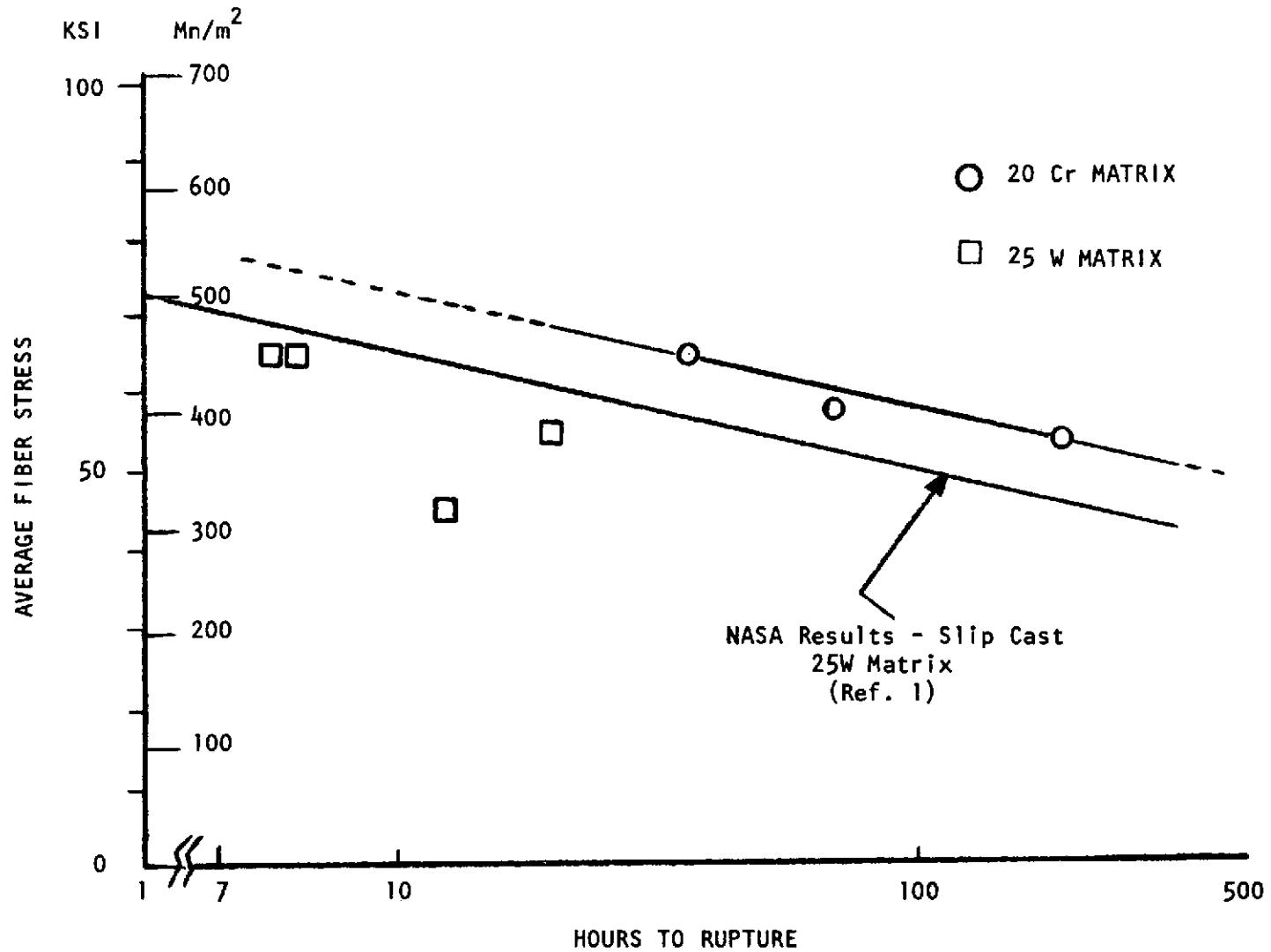

Figure 23. 1090°C (2000°F) Stress Rupture Data for Ni/W Composites.

reinforced 25 W alloy composites (1) (5). The data from Petrasek and Signorelli (1) on slip cast 25 W alloy matrix composites are also shown in Figure 23, from which it can be observed that there is a significant strength improvement with the diffusion bonded 20 Cr matrix alloy system.

Figures 24-26 show cross sections of a specimen which failed after 200 hours. The section taken was close to the failure site and, as shown in Figures 24 and 25, failure probably initiated due to oxidation of one fiber which had insufficient matrix protection. Figure 26 shows that a very small amount of fiber/matrix interaction occurred during fabrication and test exposure.

3.4 Fabrication of Thermal Fatigue Specimens

An important task on this program was the fabrication of and delivery to NASA of thermal fatigue specimens fabricated by the diffusion bonding process. System selection and processing methods were selected based on results obtained at this stage in the program.

An isothermal hot pressing system was designed and constructed. This is shown in Figure 27. This system used induction heated Mo-TZM dies inside a closed chamber and was designed for operation in vacuum or inert atmosphere.

The W-20 Cr composite system was selected based on process optimization studies and preliminary stress rupture data. Further refinements to the processing procedures were made and panels were fabricated using both monotape and multi-ply processes. Panel fabrication using the monotape process is illustrated by Figure 28. Monotape strips were assembled within a slotted frame and hot pressed to make panels from which the low gas velocity thermal fatigue specimen shown in Figure 29 could be machined. In the multi-ply process, 10-ply panels were fabricated directly and cut into cores which were then assembled in a slotted frame or alloy powder and hot pressed. The latter approach (powder assembly) required a closed die secondary fabrication method. Typical fabrication parameters were 137.8 MN/m^2 at 1090°C for 15 minutes.

A typical cross section through one of these panels is shown in Figure 30. The panels were sectioned at one end and evaluated metallographically in addition to radiographic inspection. Since the grip end would be relatively cold during the test, exposed fibers at this location were of no concern. A typical metallographic cross section is shown in Figure 31. Original powder particle boundaries could still be observed in the matrix although there was evidence of considerable matrix deformation between fibers. The filament distribution varied from a hexagonal to square packing.

A finish machined low gas velocity thermal fatigue specimen is shown in Figure 32. All specimens shipped to NASA for subsequent rig testing had the 218 CS W/20 Cr alloy composite core with either an Alloy C cladding or an Alloy B protective sheath fabricated using pre-alloyed powders.

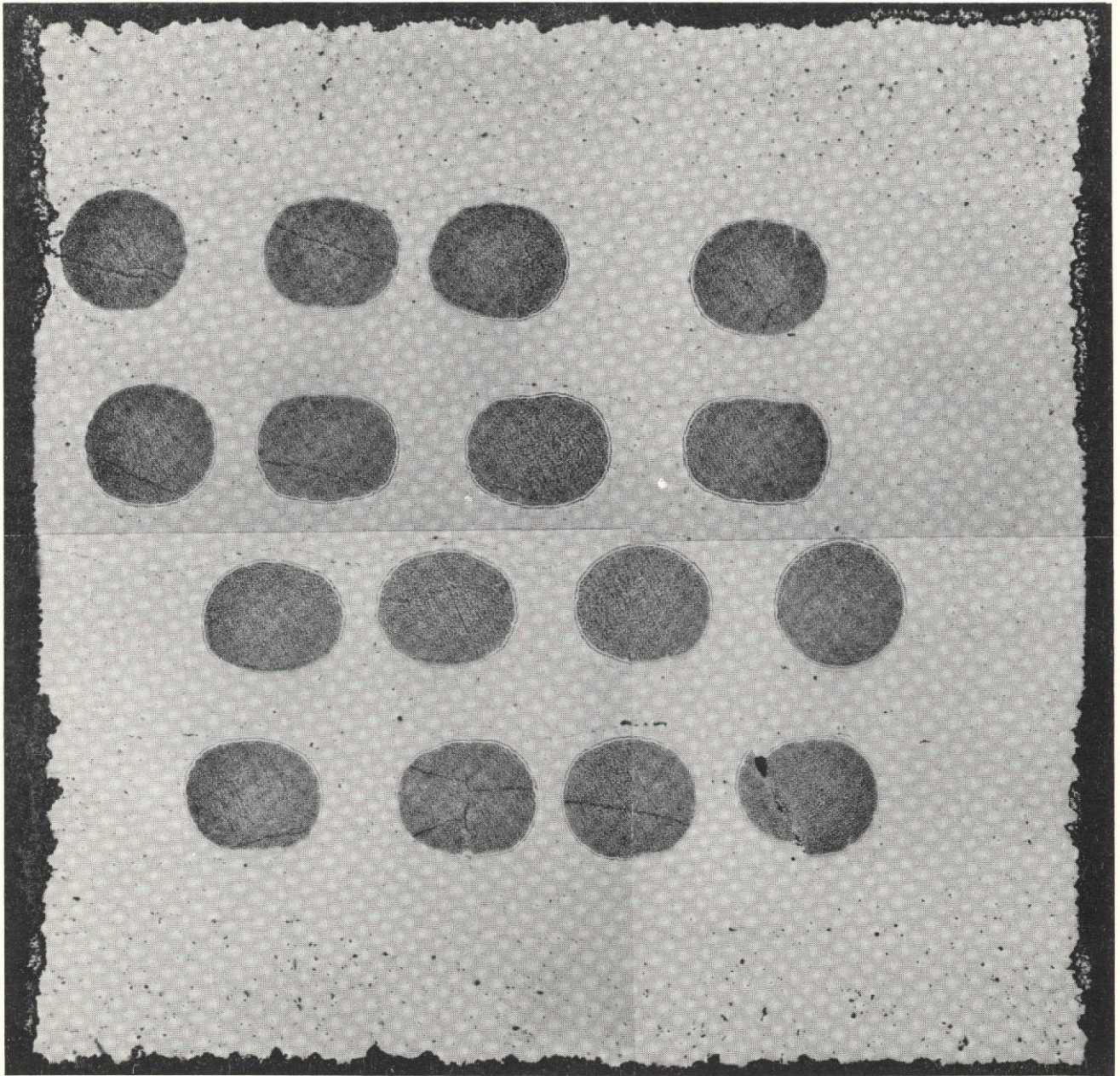

50X

Figure 24. W-20 Cr Specimen. P-18-3 After 1090°C (2000°F) - 200 Hour Stress Rupture Test.

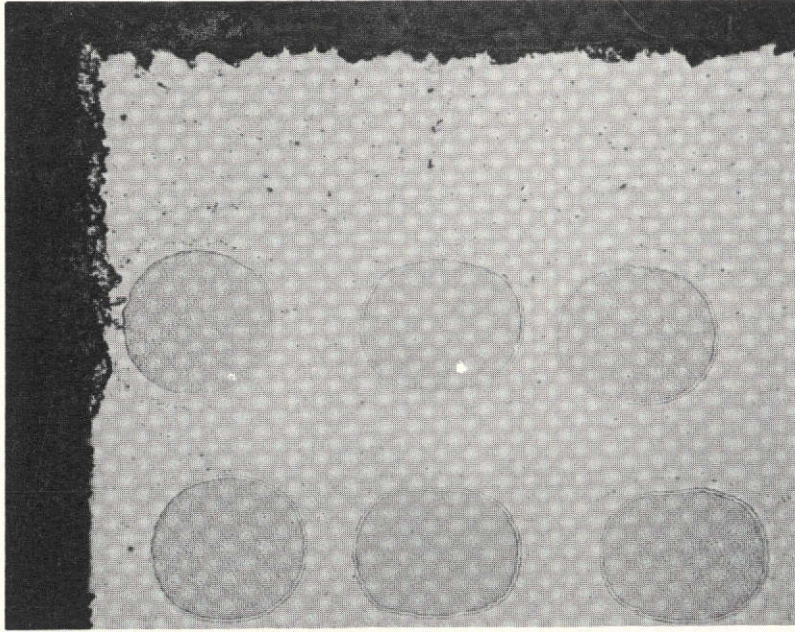

Unetched - 50X

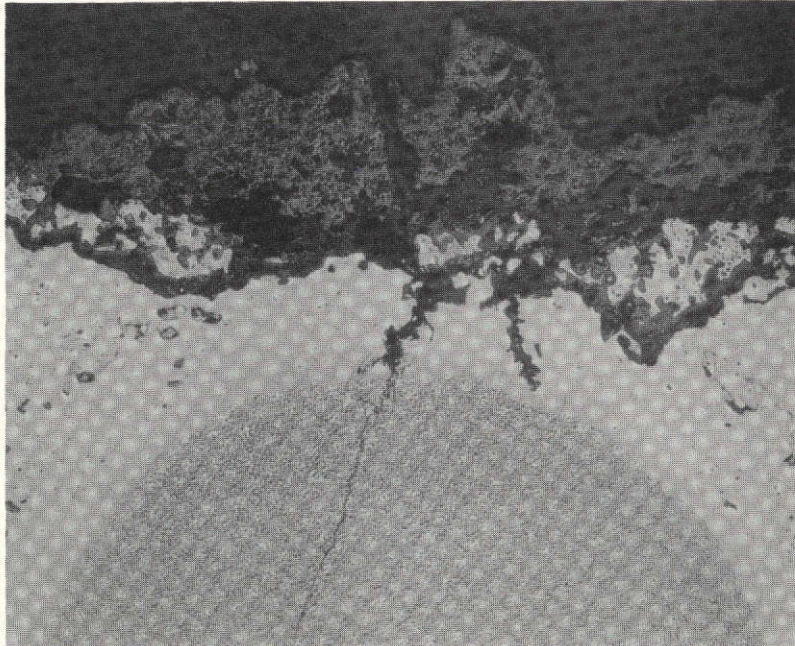

Etched - 250X

Figure 25. P-18-3 Stress Rupture Specimen. Section Close to Fracture Site.

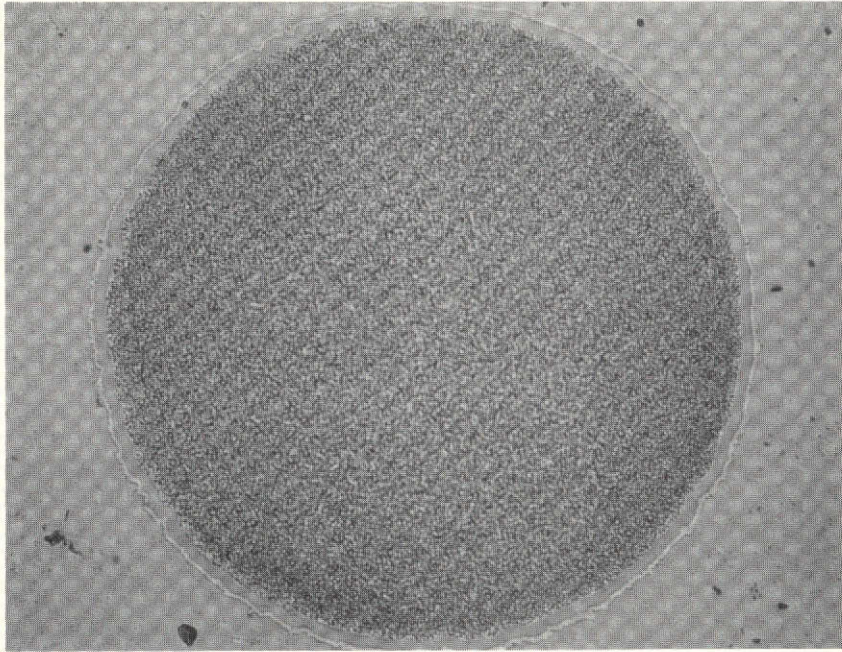

235X

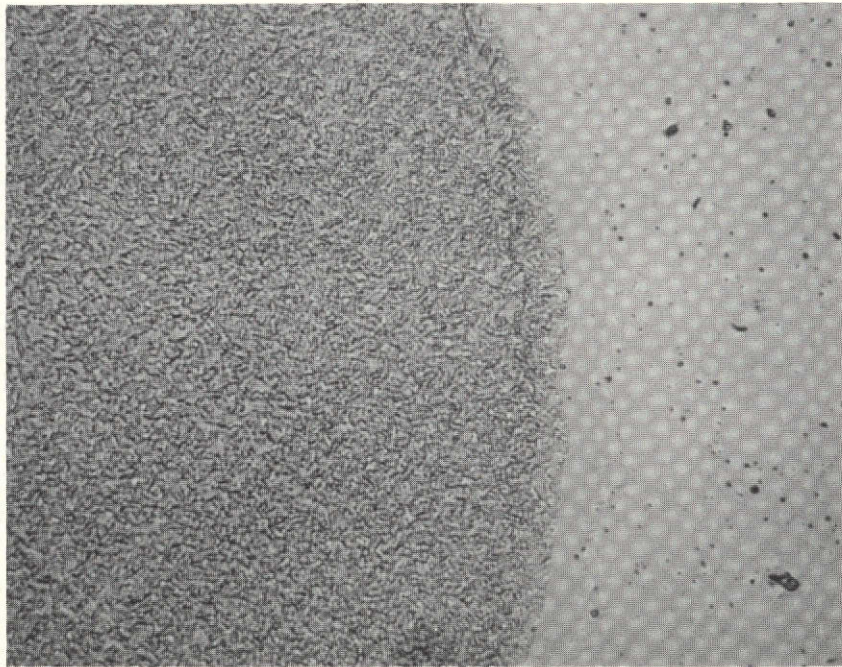

0.001 cm (0.0004") |→| ←| 690X
Total Reaction
Zone

Figure 26. P-18-3 200 Hour - 1090°C (2000°F) Stress Rupture Test.

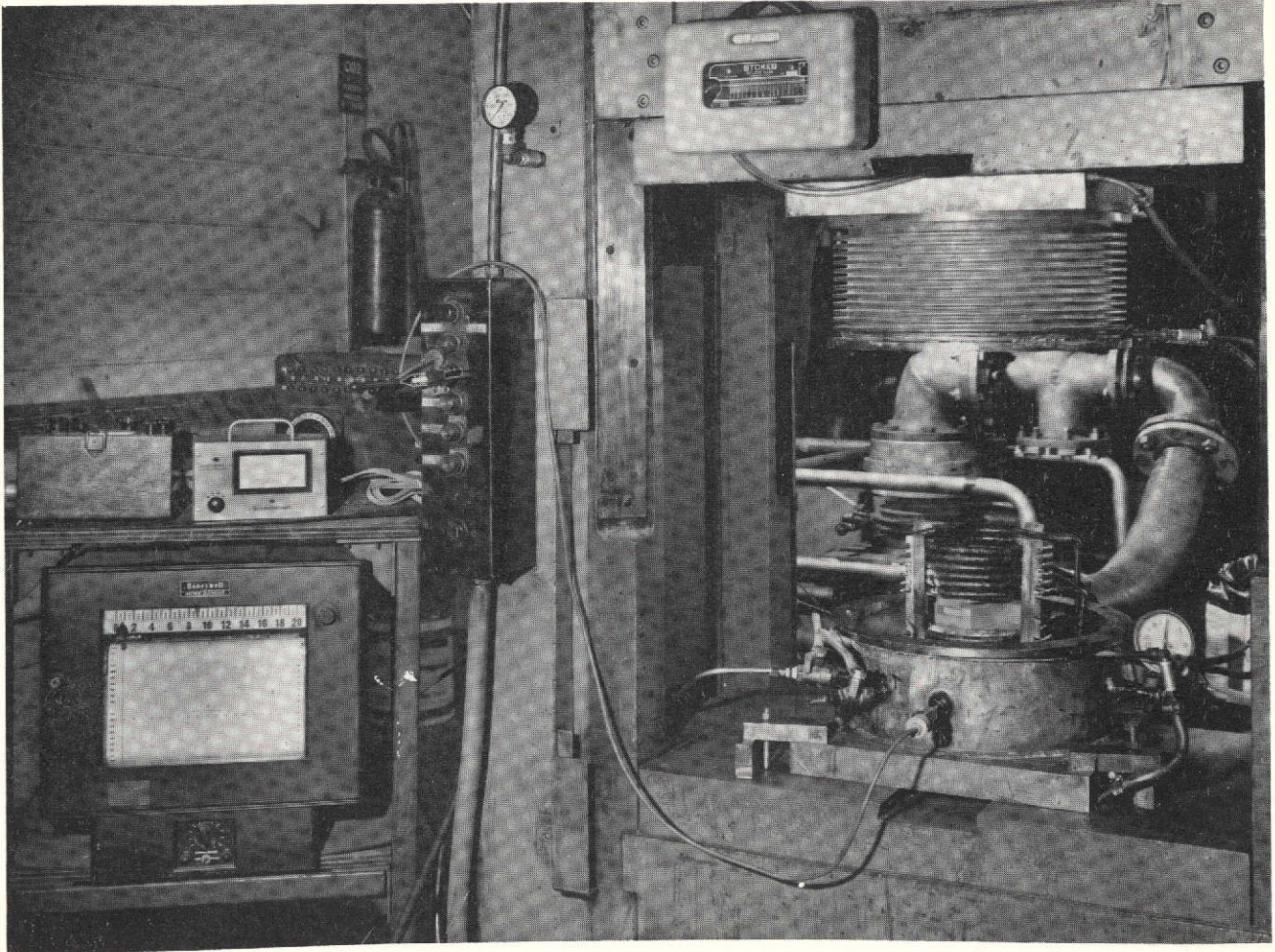
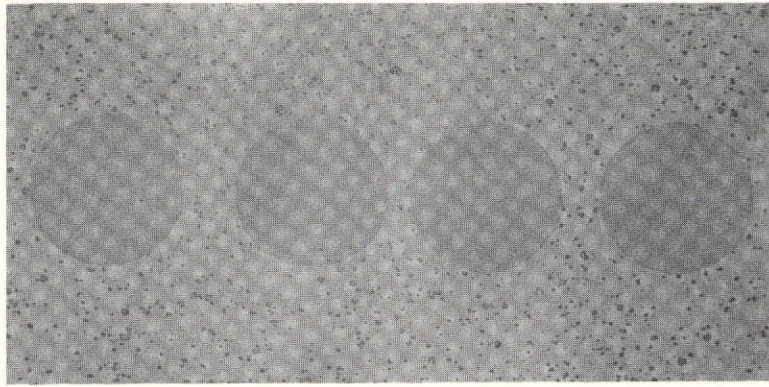
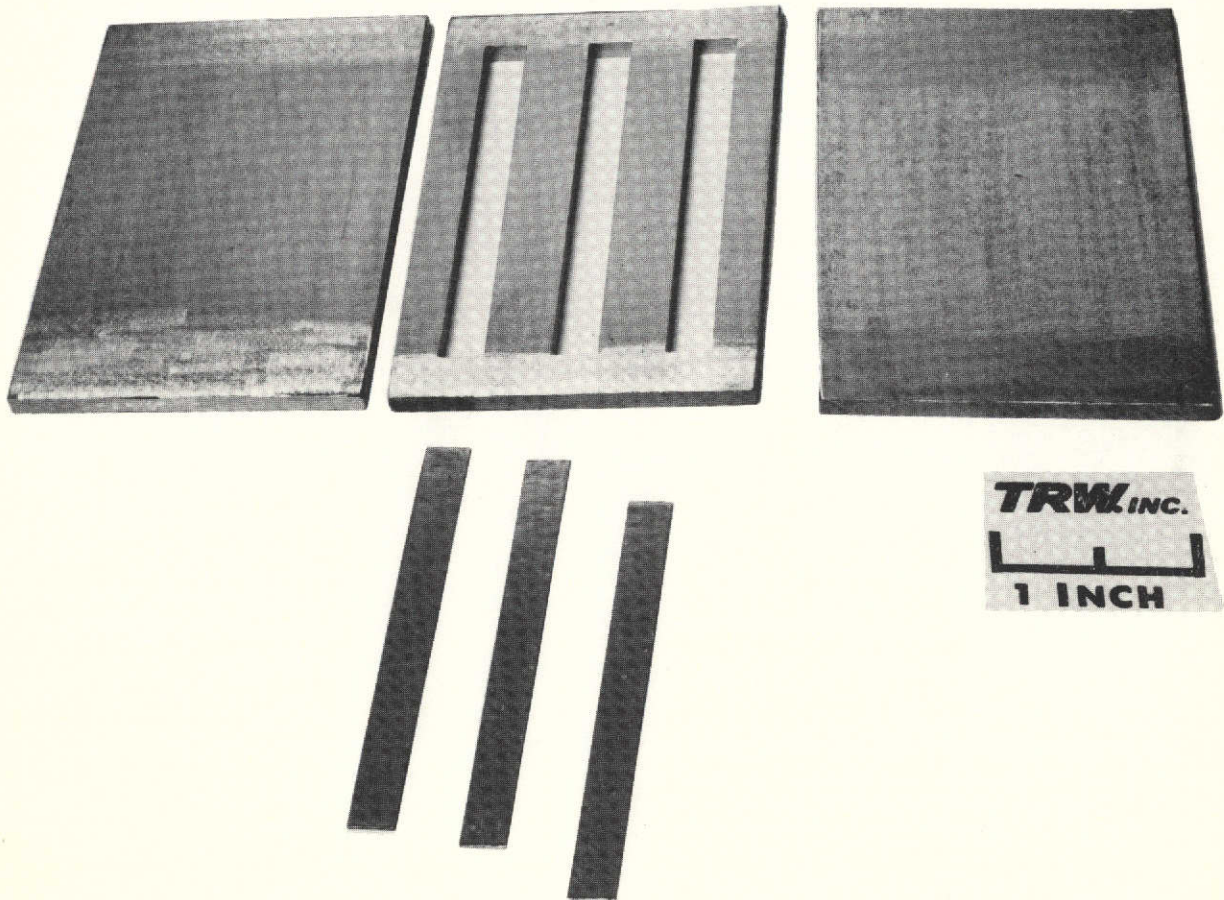

Figure 27. Controlled Atmosphere Hot Pressing System for
 Fabrication of High Temperature Composite.



A. Monotape Cross Section 50X
2-1 DA/W System



B. Monotape Strips and Matrix Alloy Components

Figure 28. Assembly of Low-Gas-Velocity Thermal Fatigue Specimen Panel.

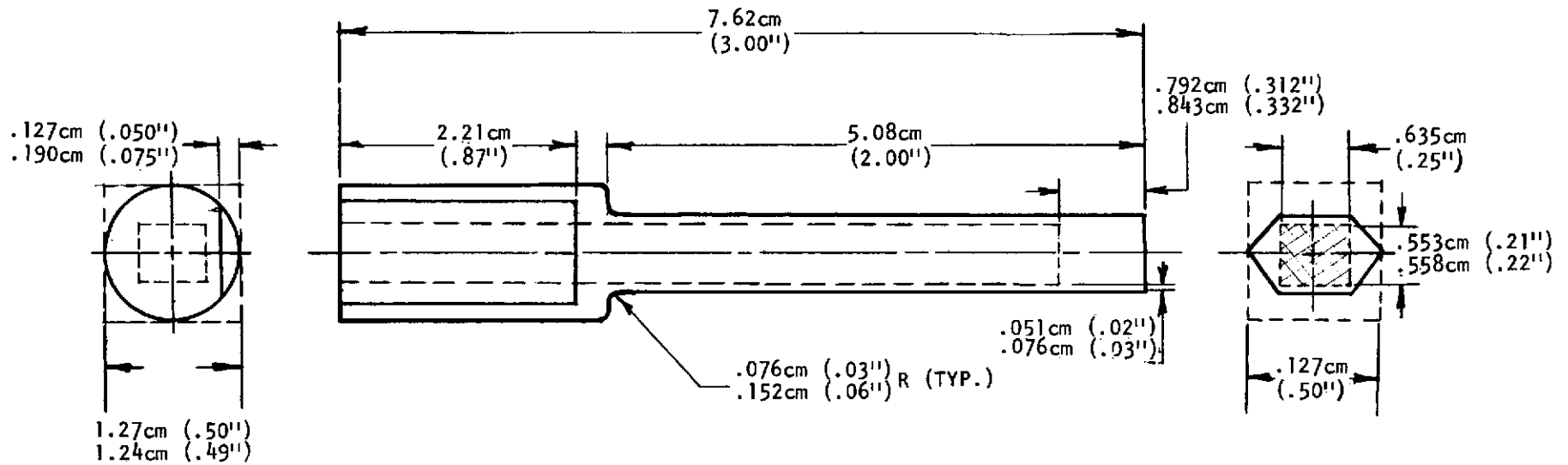

Figure 29. Low-Gas Velocity Specimen.

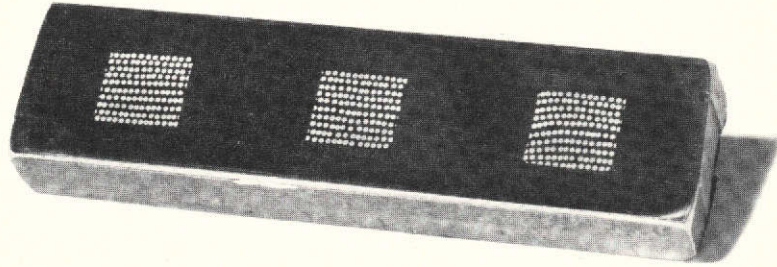
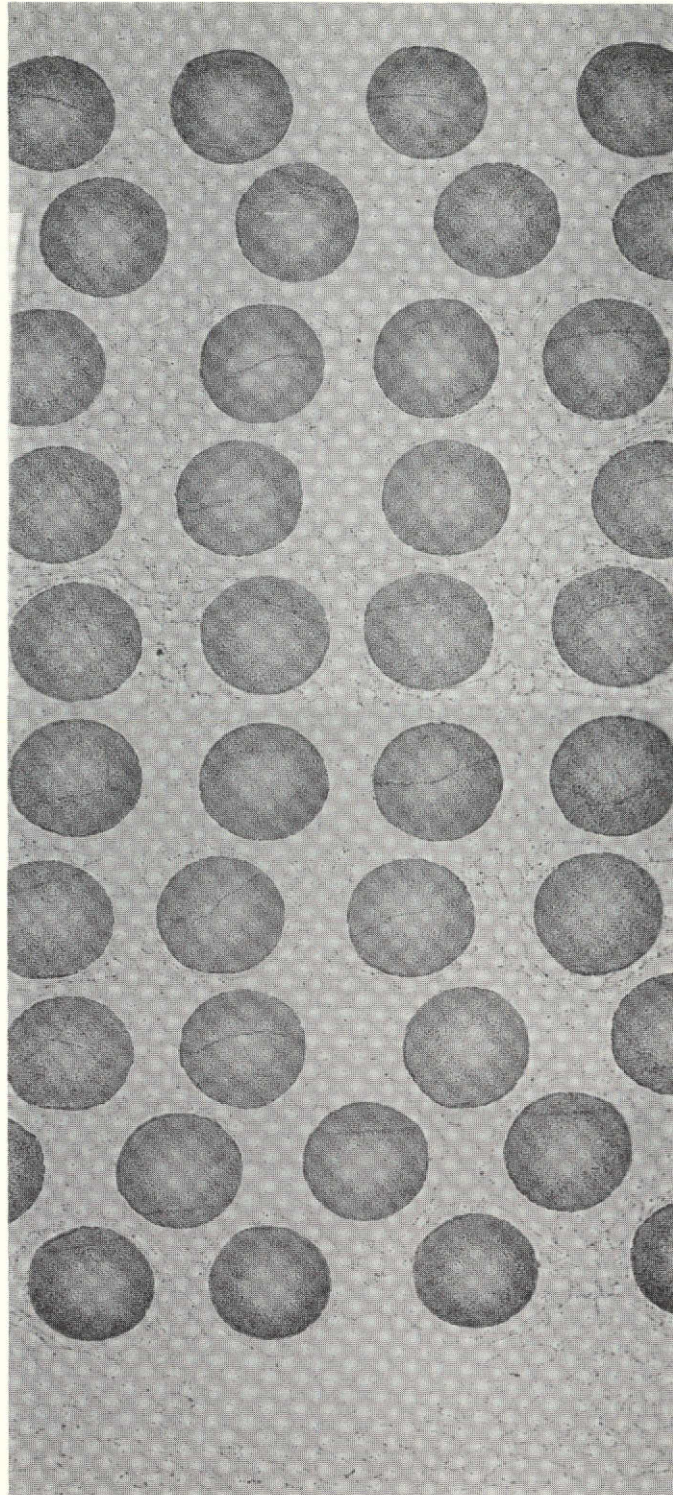

Figure 30. Cross Section Through W/Ni Alloy Composite Thermal Fatigue Specimen Panel.



50X - Reduced 20% for
Reproduction

Figure 31. Metallographic Cross Section through W/Ni Thermal
Fatigue Section

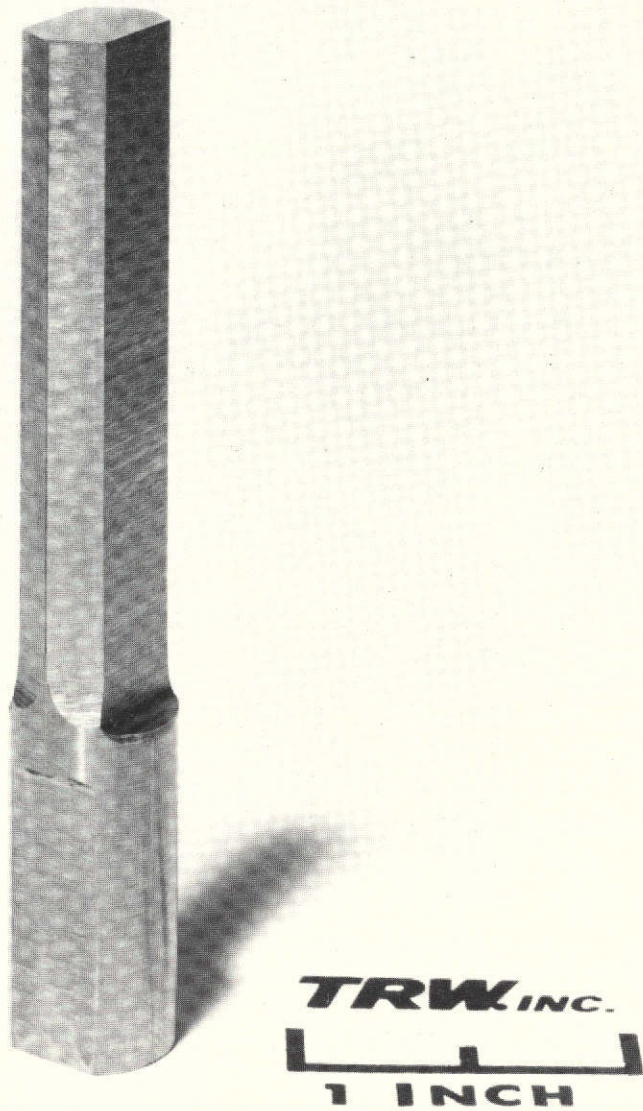

Figure 32. W/Ni Alloy Composite Low-Gas-Velocity Thermal Fatigue Specimen.

4.0 SUMMARY AND CONCLUSIONS

This program set out to develop tungsten reinforced nickel base alloy composites having properties equivalent or superior to those developed in previous NASA studies. Important to the realization of these goals was the development of improved blade oriented processing methods. The results of this first 12-month effort may be summarized as follows:

1. Diffusion bonding processes were developed for the fabrication of W/Ni alloy composites in monotape or multi-ply forms using matrix alloys in the form of pre-alloyed powders or rolled sheet.
2. The application of pre-consolidated monotapes to the fabrication of more complex shapes (stress rupture specimens with complete fiber encasement) was demonstrated.
3. Preliminary stress rupture testing indicated that efficient strengthening was achieved due to the small degree of fiber/matrix interaction and good fiber distributions. Stress rupture data obtained on the 20 Cr matrix alloy composite represented a significant improvement over the baseline NASA data on the 25 W matrix alloy composite.
4. Following further process refinements, larger panels were fabricated from which low-gas-velocity thermal fatigue specimens were machined. Shipment of these specimens to NASA represented the conclusion of this work.

Recommendations for further evaluation include:

1. Further optimization of matrix alloys, processing parameters and composite design based on response of these systems to thermal fatigue.
2. Complete characterization of the mechanical and physical properties of selected system(s) required for preliminary gas turbine blade designs.
3. Determination of the stress rupture properties of composites with advanced high strength tungsten fibers.

The work under item 1 above should be extensive and include both low-gas and high-gas-velocity thermal fatigue testing, evaluation of different volume fraction reinforcements and a composite design analysis study aimed at optimizing thermal fatigue properties.

5.0 REFERENCES

1. D.W. Petrasek and R.A. Signorelli and J.W. Weeton, Refractory Metal Fiber Nickel Alloy Composites for Use at High Temperatures. NASA TN D-4787, 1968.
2. S.S. Manson, New Directions in Materials Research Dictated By Stringent Future Requirements. NASA TMX-67885. Int. Conf. on Mechanical Behavior of Materials, Kyoto, Japan, August 15-20, 1971.
3. V.S. Moore, W.D. Brentnall and A.R. Stetson, Evaluation of Coatings for Cobalt- and Nickel-Base Superalloys. NASA CR-72359, January 1969 and NASA CR-72714, July 1970.
4. J.W. Weeton, Design Concepts for Fiber Metal Matrix Composites for Advanced Gas Turbine Blades. NASA TMX-52777, May 24-28, 1970.
5. D.W. Petrasek and R.A. Signorelli, Preliminary Evaluation of Tungsten Alloy Fiber-Nickel-Base Alloy Composites for Turbojet Engine Applications. NASA TN D-5575, February, 1970.
6. A.W.H. Morris and A. Burwood-Smith, Some Properties of a Fibre Reinforced Nickel-Base Alloy. Fibre Science and Technology (3) 1970.
7. A.W.H. Morris and A. Burwood-Smith, Fibre Strengthened Nickel-Base Alloy, AGARD Conference Proceedings, N. 73 on High Temperature Turbines, September, 1970.
8. Fiber Reinforced FeCrAlY Alloy Composites for High Temperature Turbine Blades, NASC Contract N00019-74-C-0122.
9. T. Montalbano, J. Brett, L. Castleman, and L. Seigle, Nickel Induced Recrystallization of Doped Tungsten. Trans. AIME 252, 1973-79, (1968).
10. W.D. Klopp, P.L. Raffo, and W.R. Witzke, Strengthening of Molybdenum and Tungsten Alloys with HfC, Journal of Metals, 27, June, 1971.
11. G.W. King, Development of Wire Drawing Processes for Refractory Metal Fibers, NASA CR-120925, January 1972.
12. D.W. Petrasek and R.A. Signorelli, Stress-Rupture Strength and Microstructural Stability of W-Hf-C Wire Reinforced Superalloy Composites, NASA TM X-71529, April 15-16, 1974.
13. W.B. Kent, Wrought Nickel-Base Superalloys. NASA CR-72687, March, 1970.
14. J.C. Freche, R.L. Ashbrook and W.J. Waters, Application of Powder Metallurgy to an Advanced Temperature Nickel-Base Alloy, NASA-TRW VIA, NASA TN D-6560, November, 1971.