

**N75 11282**

**LOW COST AUTOMATED PRECISE TIME MEASUREMENT SYSTEM**

**A. Alpert  
P. Liposchak  
Newark Air Force Station**

**ABSTRACT**

**The Aerospace Guidance & Metrology Center (AGMC) has the responsibility for the dissemination of Precise Time and Time Interval (PTTI) to Air Force timing systems requiring microsecond time. In order to maintain traceability to the USNO Master Clock in Washington D. C., and accomplish efficient logging of time and frequency data on individual precision clocks, a simple automatic means of acquiring precise time has been devised.**

**The Automatic Time Interval Measurement System (ATIMS) consists of a mini-computer (8K Memory), teletype terminal, electronic counter, Loran C receiver, time base generator and locally-manufactured relay matrix panel.**

**During the measurement process, the computer controls the relay matrix which selects for comparison 13 atomic clocks against a reference clock and the reference versus Loran C. Because portable clocks are scheduled for periodical time synchronization trips, the computer performs a status check on the availability of each clock before attempting to read its time. Any clock not available is noted as such and no comparison is made. After all clocks are compared, the data is reported on the teletype. Only data and clock status at the 1800 UT reading are retained. ATIMS then becomes dormant until the next automatically scheduled execution period.**

**At any time during automatic operation, manual mode may be employed. This permits the operator to control the execution of ATIMS and thereby measure all clocks at his discretion. Also at this time, Loran C phase values for a particular day can be entered via the teletype. The times of all available clocks, relative to USNO, for that day (up to 10 days past) are then computed and reported on the teletype. When this process is completed, the operator then reschedules ATIMS so that operation is cued by the system clock.**

**Through use of the system teletype, the operator is able to set the system clock (hours, minutes and seconds), examine and/or modify all clock data and constants, and set measurement intervals. This is done in a conversational manner. A logic flow diagram, system schematic, source listing and software components will be included in the paper.**

**PRECEDING PAGE BLANK NOT FILMED**

## INTRODUCTION

The Aerospace Guidance and Metrology Center (AGMC) has the responsibility for the dissemination of Precise Time and Time Interval (PTTI) to Air Force timing systems requiring microsecond synchronization. In order to maintain traceability to the USNO Master Clock in Washington D. C. and accomplish efficient data logging of individual precision clocks, a simple automatic means of acquiring precise time has been devised.

To appreciate the magnitude of the data collected, the AGMC timing teams now visit over 36 sites every 6 months. Most Air Force systems have installed a parallel system consisting of 2 or more clocks per site. Raw data retrieved by the teams include initial and final frequency offsets, "C" field or Zeeman calibrations, pulse characteristics, and 6 month maintenance where apropos.

Before the installation of the Automatic Time Measurement System (ATIMS), data logging of portable clocks and the laboratory standards that make up the AF which is described below could not readily be made on the weekend or after normal working hours. In addition, LORAN C phase information related to 1800 UT and critical for steering of the reference standards, required that personnel be "on hand". Another important feature of the ATMS is its ability to make repetitive measurements at scheduled times. This is advantageous for recording warm-up time of oscillators and time drift of less stable quartz crystal clocks.

The Automatic Time Measurement System consists of a minicomputer, teletype terminal, electronic counter, LORAN C receiver, time base generator and locally manufactured relay matrix panel. The physical location and configuration of these items in the PTTI laboratory are shown in Figures 1 and 2.

The Air Force Master Clock consists of five cesium beam oscillators (HP 5060A) and dividers (915 Timing System Incorporated) that provide a basic stability and parallel reliability to the timing system. Steering of the AF Master Clock is accomplished by phase tracking the US Coast Guard LORAN C broadcast originating at Cape Fear, North Carolina. Phase information is obtained from an automatic tracking LORAN C receiver (Aerospace Research Incorporated 504) that has a built-in epoch monitor. The epoch monitor compensates for the offset in the specific pulse repetition rate (99,300 microseconds) of the Cape Fear transmission and produces a time of coincidence (TOC) pulse every second. The epoch monitor was an important ingredient in the Automatic Measurement System because it provides direct readout of the propagation delay on the counter. This makes for ease of storage and computation by the computer without additional programming steps to mask unwanted numbers.

Basically, data acquisition and manipulation of data by the computer occurs in the same sequence as previous manual operation. Daily at 1800 UT the TOC pulse from the receiver is compared via an electronic counter (HP 5245L) to a reference clock (usually one of the five (5) clocks that make up the AF Master Clock). The reference standard is then compared against the other working standards and portable clocks. At some later point in time, phase corrections for Cape Fear are received by routine Navy TWX from the USNO. These corrections are added algebraically to the previous logged data to obtain a time drift history.

#### SYSTEM DESCRIPTION

The Central Processing Unit (CPU) shown in the Figure 3 is the HP 2100A Minicomputer. The Time Base Generator (TBG), Teletype (TTY), Counter and Relay Output Register input/output devices are plug-in interface cards that are located inside the HP 2100A. The Minicomputer has an 8K magnetic core at the present time, but can be expanded up to 32K maximum. Of the 8K available memory, approximately 5K words are used for manufacturer software, including DACE (Data Acquisition Control Executive), library routines and drivers. Of the remaining 3K memory, our User program incorporates 1800 words (decimal). While the block labeled CPU indicates 4 subsystems or interface cards, a total of 14 interface slots are available inside the HP 2100A to control peripheral devices.

The TBG measures real time intervals in decade steps from 0.1 ms to 1000 seconds. The 100 kHz crystal controlled oscillator used as the frequency standard for the Time Base Generator allows generation of timing signals to within 1/2 second per 24 hour day. The Time Base Generator is used to provide timing pulses to the software counter that can be initialized to a real time clock. The software program that allows scheduling data acquisition at preset times is called DACE and will be discussed in more detail.

The TTY interface card provides control of the TTY and allows the operator to examine and/or modify constants and clock data. The time of day, scheduling of clock readings and manual operation is also entered via the TTY.

The Counter interface card enables the Counter to take the clock readings. After the CPU directs the Counter interface card to take a reading, a sub routine called "EPOCH SELECT" drives the relay register card which in turn closes various coaxial relays supplying the START-STOP signals to an Electronic Counter. A time delay of 200 milliseconds is provided within the subroutine to permit contact bounce to subside. Another User written subroutine, called "TIME OUT", checks the Electronic Counter for a start signal as each clock pulse is selected by the relay register. Each clock is permitted a maximum of 10 seconds to

supply a start signal. If a clock pulse is present within the 10 second interval, the computer stores a "1" and a "2" if not present. This is called the status check of the clocks and the ones and the twos for a given day's readings can be printed out upon operator's request.

The four coaxial relays shown are Amphenol 50 ohm 1P 6T. The relays are 26 VDC with a maximum operate and release time of 20 ms.

As the relays are activated, each clock pulse in turn gates the start input of the Counter. The reference clock pulse is normally switched through the 4th relay (right hand side of slide) into the STOP input of the Counter. Because the last reading is the LORAN C delayed signal, the reference clock is switched to the start input and the LORAN pulse to the STOP input of the Electronic Counter.

#### SYSTEM SOFTWARE

The software for the Automated Time Measurement System consists of HP supplied program called DACE and the User Written Program. The User Written Program selects clocks to be read, checks status of clocks and calls upon DACE to automatically schedule measurements.

The Data Acquisition and Control Executive (DACE) program shown in Figure 4 performs specified tasks at specified intervals. In other words, DACE in conjunction with the Time Base Generator can take a clock reading every hour and relate it to time of day. The DACE also allows the operator to examine and/or modify the scheduled time intervals, starting times, clock data and constants such as LORAN C propagation delay without interruption of the program. The scheduled clock readings (at 1800 UT) are done in automatic mode operation. DACE also allows the operator to check that clock readings in automatic mode will perform as planned. This is done by executing or stepping through the program in the manual mode.

Every 10 milliseconds, the Time Base Generator interrupts and increments the system clock. If present time matches or coincides with the next scheduled time, the task is put into operation. If not, the task remains dormant.

The maximum time interval that can be scheduled is 9 hours, 6 minutes, 6 seconds (32767 seconds). Therefore, 8 hour interval (submultiple of 24 hours) was chosen. Clock comparisons are printed out every 8 hours and the User Written Program checks for the 1800 reading.

In automatic mode, several operations are accomplished by the User ~~Written~~ Program (see Figure 5). If the time of day coincides with the 1800 UT, ~~12 minute~~

window, the computer stores the clock readings in a floating point array. This array is associated with the last digit of the Julian date. Up to 10 days readings can be stored, recalled at a later time and corrected to the USNO. Also stored are the status or availability of the clocks at the time of measurement. The status which is reported by 1 for available and 2 for not available, is also stored up until 10 days in a linear integer array. The reason for the status check is that clock readings are corrected by recalling from memory a group (array) of data related to a Julian date. The status check reveals whether the clock was "on hand" that day or 10 days previous, since clock readings are replaced every 10 days.

In Manual mode, the TTY asks whether EPOCH or LORAN C (LC) phase measurements? By typing a number other than one, the clocks are compared to the reference standard only. The TTY then prints out clock # vs. AGMC reference. Entering 1 requests LC phase information. The TTY then asks for the Julian date and the USNO phase correction. The clocks versus USNO are then printed out on the TTY.

**AUTO:** Tasks are automatically executed at intervals specified.

**EXECUTE TASK N:** Task may be called up for manual execution.

**SET TIME OF DAY:** Time of day may be entered. The executive program will keep a 24 hour digital clock to within 0.5 second/day.

**RELEASE:** Parts of the executive program may be released to the output buffer. This provides additional memory locations for storing out-data.

**TASK TIMES:** Interval and phase times are entered by the operator. For instance, Interval = 8:00 and Phase = 0:0:15.

**TASK CONSTANTS:** Change clock data, replace lost data, change LORAN C delay, etc.

**ENABLE EXAMINE:** Provides option of the examination of current values before new values of times and/or constants are entered.

**TTY/PHOTOREADER:** Provides option of entering new task times and constants through TTY or photo reader.

## **SUMMARY**

**This ATMS is a means of automatic measurement, collection and correction of the epoch times of the primary standard and portable clocks, with a minimum of laboratory personnel intervention. Measurement can be set to execute at prescribed times of the day with only those measurements at a selected time of the day being stored in the computer memory.**

**Manual operation is provided so that laboratory personnel may check past data, (Maximum of 10 days) relative to the USNO master clock.**

**The collection of data will occur only when the time of automatic execution falls within a time window, the hours, minutes, and seconds parameters of the integer array. Outside this window, execution is exactly the same as those measurements in the manual mode where the clocks are read, not stored or reported on the teletype.**

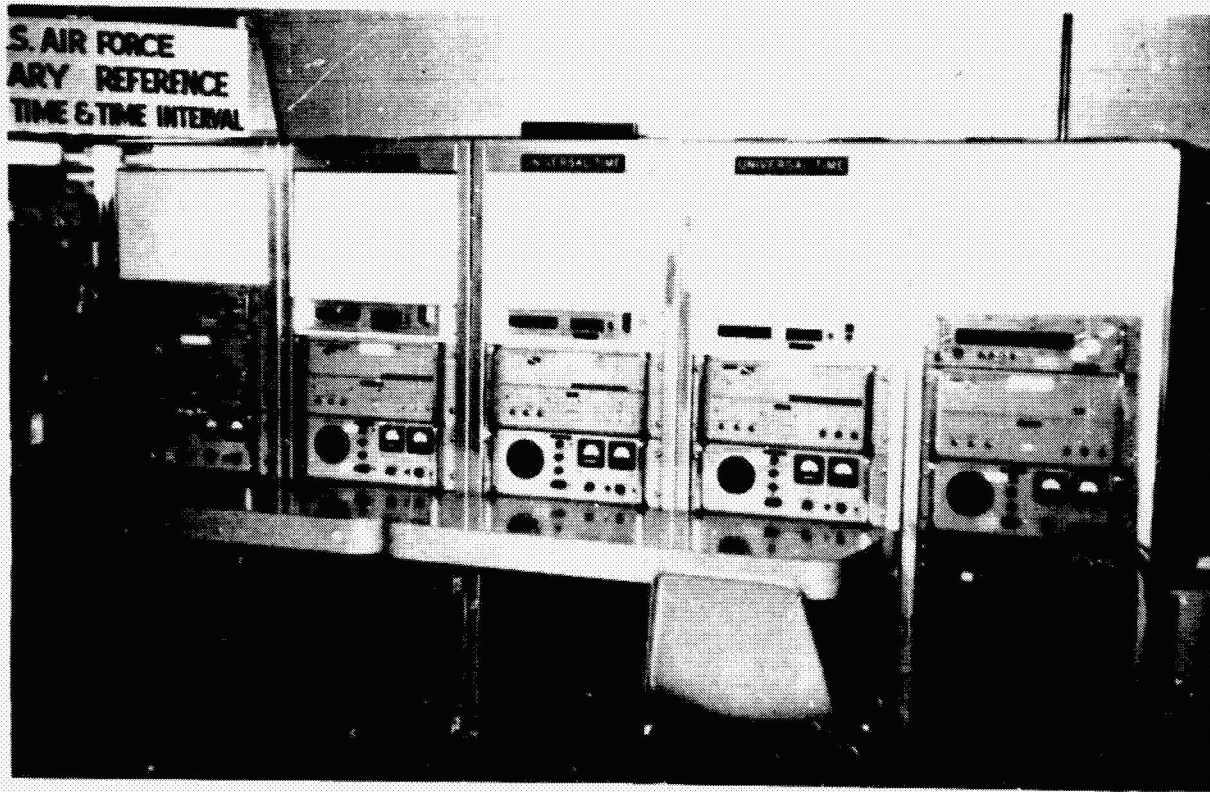

Figure 1. USAF Master Clock

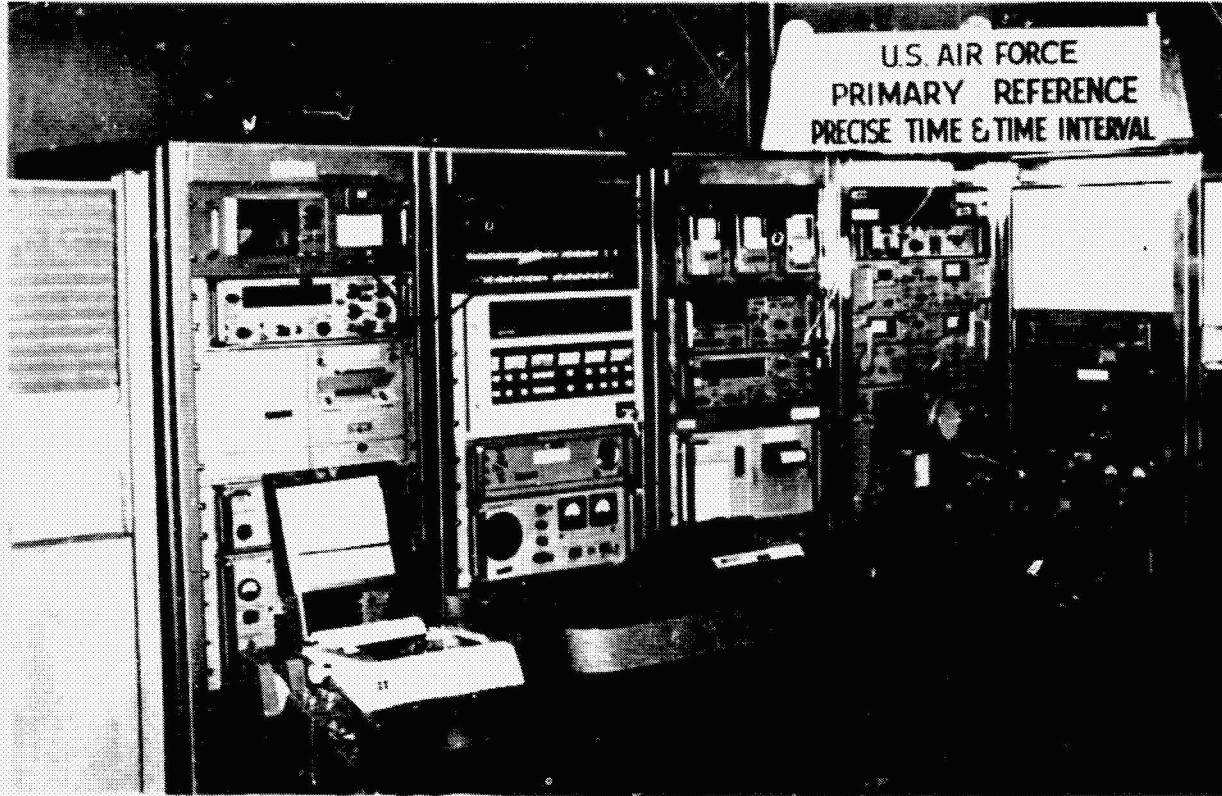

Figure 2. Computer, TTY, and Relay Panel



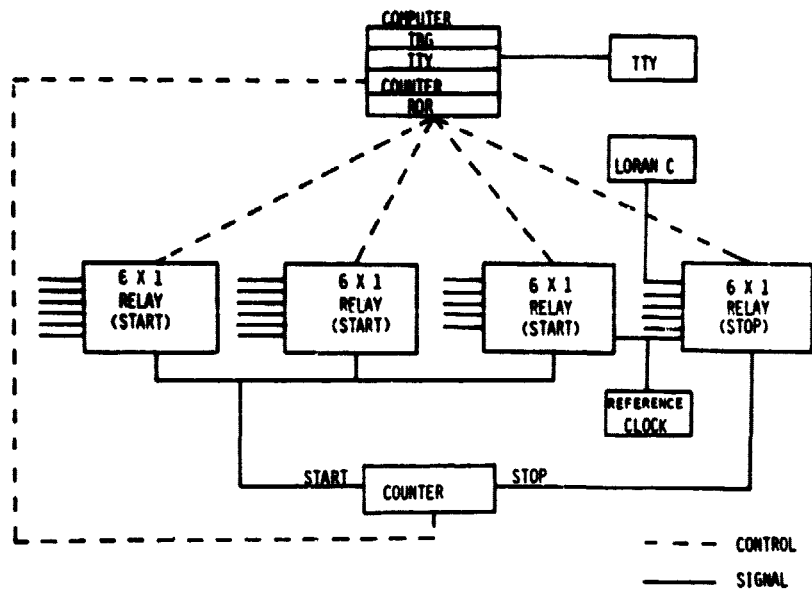

Figure 3. Automatic Time Measurement System

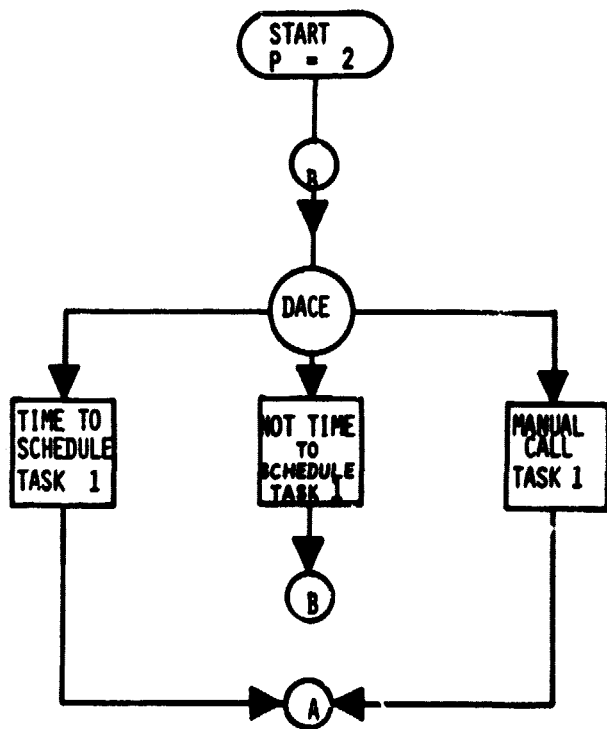

Figure 4. General Logic Flow Diagram

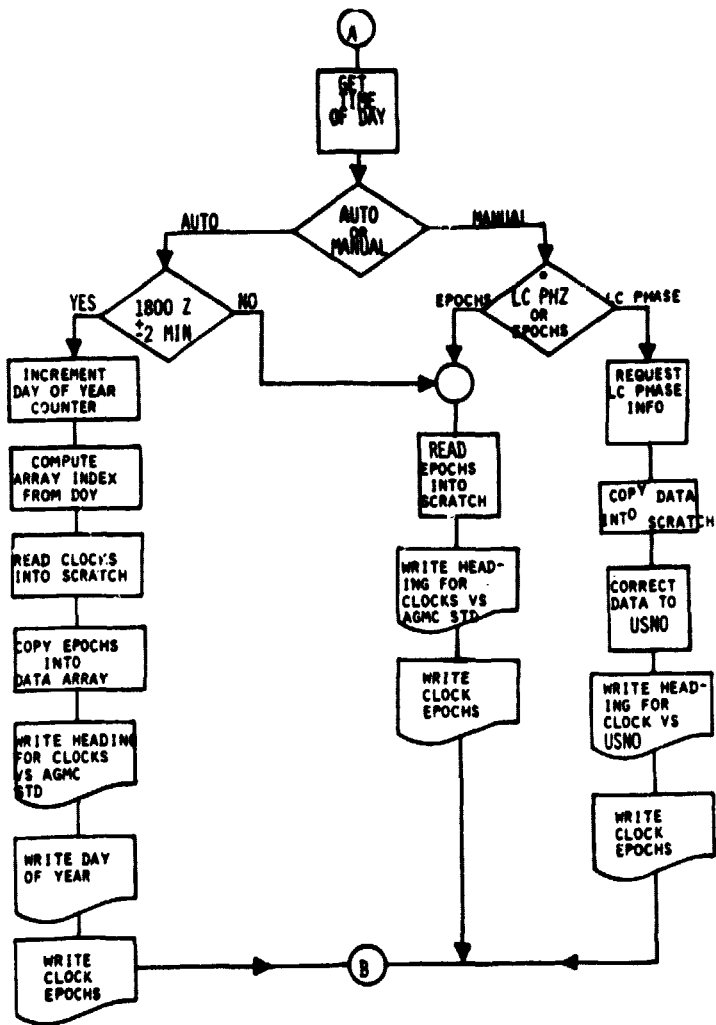

Figure 5. General Logic Flow Diagram (Cont'd.)

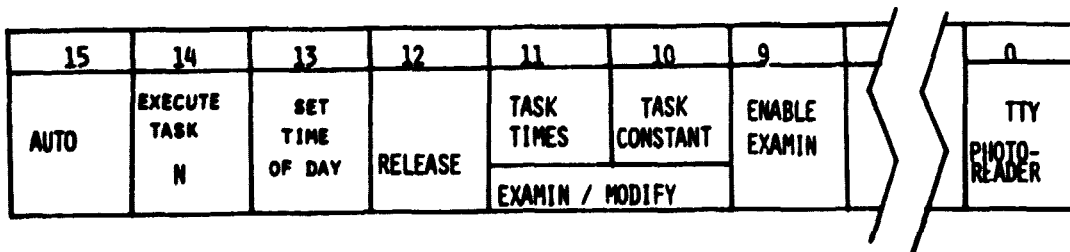

Figure 6. HP 2100 A Program Switches

**QUESTION AND ANSWER PERIOD**

**MR. ALPERT:**

**Any questions?**

**(No response.)**

**MR. CHI:**

**That was a very good paper.**