

N75 11291

FLEXIBLE BULB—LARGE STORAGE BOX HYDROGEN MASER*

V. Reinhardt**
Harvard University

ABSTRACT

The principal limitation on the accuracy of the hydrogen maser as a primary frequency standard has been the irreproducibility of the frequency shift caused by collisions of the radiating atoms with the walls of the vessel containing them. The flexible bulb-large storage box hydrogen maser allows one to correct for this wall shift within a single device, sidestepping the reproducibility problem, and reducing the frequency error from the wall shift to the level imposed by the device's stability. The principles of the device are discussed including the flexible bulb technique and the complications caused by a multiple region storage bulb. The stability of the device is discussed including a comparison with an ordinary hydrogen maser. Data is presented from a working flexible bulb-large storage box hydrogen maser demonstrating the feasibility of the device and showing some of its operating characteristics. The flexibility of the device is demonstrated by showing how the device's added degrees of freedom allow ~~unmeasurable~~ parameters unmeasurable in an ordinary hydrogen maser. measurement of

INTRODUCTION

The hydrogen maser, a quantum oscillator operating on the hyperfine transitions of atomic hydrogen, has repeatedly demonstrated frequency stabilities of one part in 10^{14} or better,¹ but has been limited in accuracy to no better than 2 parts in 10^{12} by a non-reproducible frequency shift.² The flexible bulb-large storage box hydrogen maser is a device which allows one to correct for this shift, greatly improving the accuracy of the hydrogen maser as a primary frequency standard. This paper will deal with the construction and testing of such a maser.

The frequency shift which limits the hydrogen maser's accuracy is the dark side of what gives the maser its great stability. Atomic hydrogen in an upper hyperfine state can bounce more than 10^4 times on a teflon surface before it is relaxed to the ground state.³ Using this, one can confine excited hydrogen in a teflon coated storage bulb for about one second, allowing one to produce a maser operating at 1.4 GHz whose atomic linewidth is only one Hertz. But atomic collisions with the teflon walls of the storage bulb also produce a frequency shift as well as relaxation, and this wall shift is not reproducible from storage bulb to storage bulb.^{4,5} Only after a comparison of many hydrogen masers with each other and

*Supported in part by a grant by the U.S. Office of Naval Research
**Presently at NASA Goddard Space Flight Center

with cesium clocks was a ten percent correction for the wall shift arrived at yielding the present uncertainty of about 2 parts in 10^{12} for the hydrogen hyperfine transition.²

To reduce the effects of the wall shift, two approaches were taken. First, it was reasoned that if one reduced the rate of atomic collisions with the walls of the storage bulb by making the storage bulb larger, one would obtain a maser with a reduced wall shift. This was done in the design and construction of the large storage box hydrogen maser.^{6,7} The mean free path between wall collisions was a factor of ten bigger, and as predicted, the wall shift was a factor of ten smaller. Second, it was reasoned that, if without changing the surface, one could change the mean free path between wall collisions in a known way, one could calculate, from the observed frequency shift, the wall shift for that particular maser, and hence, the unperturbed hyperfine frequency.⁸ This was tried, first, with a teflon squeeze bottle as variable mean free path storage bulb,⁹ and second, with a flexible cone which could be flipped inside and out as part of a variable mean free path storage bulb.¹⁰

As tried the flexible bulb method had several shortcomings. First, the change in mean free path could not be measured as accurately as one would have liked. Second, the flexible bulb, being inside the microwave cavity which was part of the maser, tended to make the cavity frequency more unstable. And third, when the flexible storage bulb was convoluted, maser oscillation was difficult to achieve.

To overcome these problems N. F. Ramsey proposed to combine the flexible cone with the large storage box maser. First, the wall shift in the large storage box maser is a factor of ten smaller, so the mean free path measurements are much less critical. Second, in the large storage box maser, the flexible cone would not be inside the microwave cavity, so maser stability would not be affected. And third, in the large storage box maser, there is no problem getting the maser to oscillate with a flexible cone in either cone position.

THE LARGE STORAGE BOX MASER

A schematic diagram of the flexible bulb-large storage box hydrogen maser is shown in Figure 1. A beam of state selected atomic hydrogen is produced, just as in an ordinary hydrogen maser, by an RF dissociator and a state selecting hexapole magnet. The beam then enters a large teflon coated storage box which is outside two microwave cavities, but which is connected through large openings to storage bulbs inside the cavities. During a stimulated transition the atoms wander randomly between the storage box and the two cavity storage bulbs. One large microwave cavity is not used because the atoms average the oscillating magnetic field over the storage bulb, and so to obtain an appreciable average

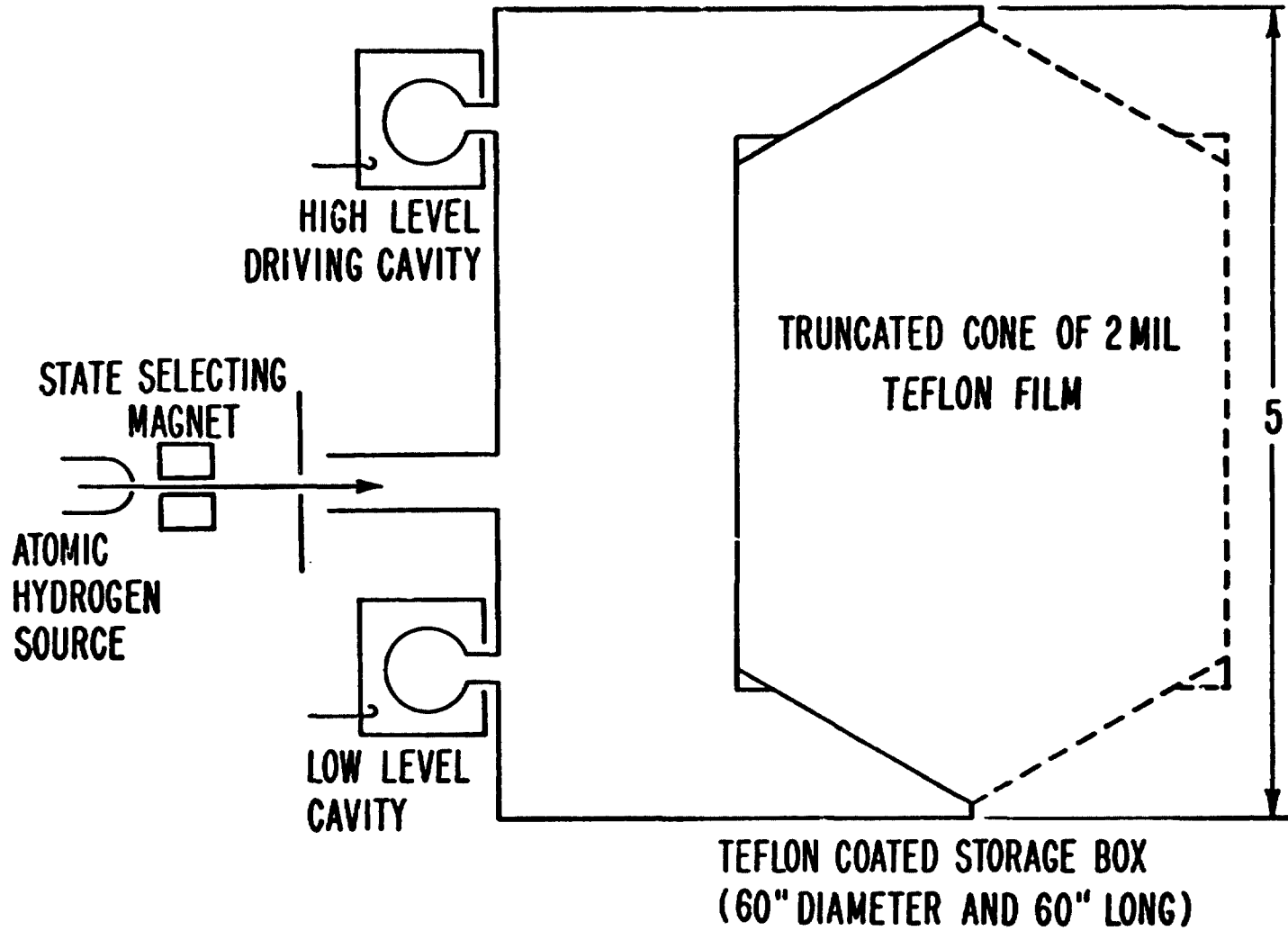

Figure 1. Schematic Diagram of the Large Storage Box Maser with Flexible Box

oscillating field to drive the transition, one must use a cavity whose standing wave in the storage bulb does not have regions of opposing phase. The whole device is placed inside a vacuum can which is inside a triple layer of Molypermalloy shields. As in the ordinary hydrogen maser, a solenoid provides a small static magnetic field parallel to the average oscillating magnetic field. Finally to obtain oscillation, one must connect an 80 db microwave amplifier between the two microwave cavities. A picture of the maser is shown in Figure 2.

The operation¹¹ of the large box maser is analogous to that of Ramsey coils in a cesium beam. Even though the atoms wander randomly between the cavities, on resonance the atoms' spin precession rate exactly matches the oscillating field frequency, so the precessing spins are always in phase with the oscillating field when the atoms enter the cavities. Thus the atoms effectively see the oscillating field for their whole relaxation time in the storage box, so the maser acts like an ordinary maser with a linewidth governed by the total storage box relaxation time. But again analogously to Ramsey coils, the effective field the atoms see and the effective atomic magnetization the cavities see are reduced from the real quantities by the ratio of the time the atoms spend in the cavities to the total relaxation time. Ordinarily this would reduce the effective coupling between the oscillating field and the atomic magnetization to the point where one couldn't get the maser to oscillate, so to get the maser to oscillate, one must artificially increase the oscillating magnetic field with the 80 db microwave amplifier to the point where the field is strong enough to selfconsistently produce stimulated emission. One cannot get something for nothing though; the low level cavity signal is still very weak compared with an ordinary maser, about 10^{-16} watts as compared with 10^{-12} watts, so thermal noise in the large box maser is much more of a problem. Because of this, in the large box maser, short term frequency stability is much worse than in an ordinary maser; in the large box maser, one trades off short term stability for long term accuracy.¹

THE FLEXIBLE CONE

On the end of the storage box, in order to change the storage box's mean free path between wall collisions, there is a truncated teflon cone made of 2 mil FEP teflon film. To flip the cone under vacuum, a teflon coated aluminum plate which forms the upper base of the cone is moved in and out by a scissor jack driven through a gear box, chain drive, and rotary motion feedthrough by a motor outside the vacuum system. The jack and drive system are lubricated throughout with dry, high vacuum lubricants to ensure a clean vacuum system. A turns counter is connected to the motor to ensure the reproducibility of the two cone positions. To ensure that the cone is tight yet not stressed in both positions, the upper base plate is attached to the jack through a set of gimbals. For a picture of the cone and drive system, see Figure 3.

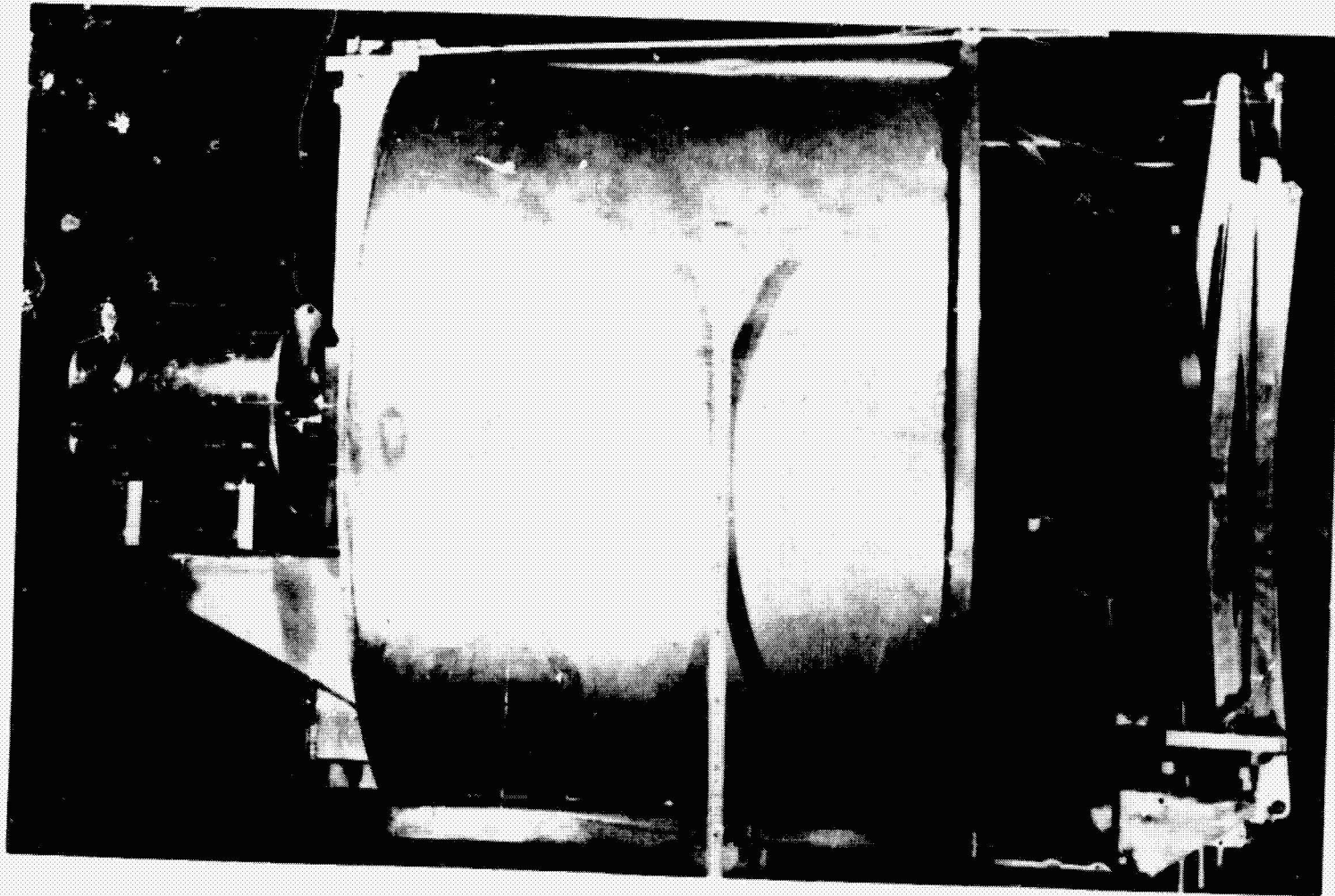

Figure 2. Flexible Cone-Large Storage Box Hydrogen Maser

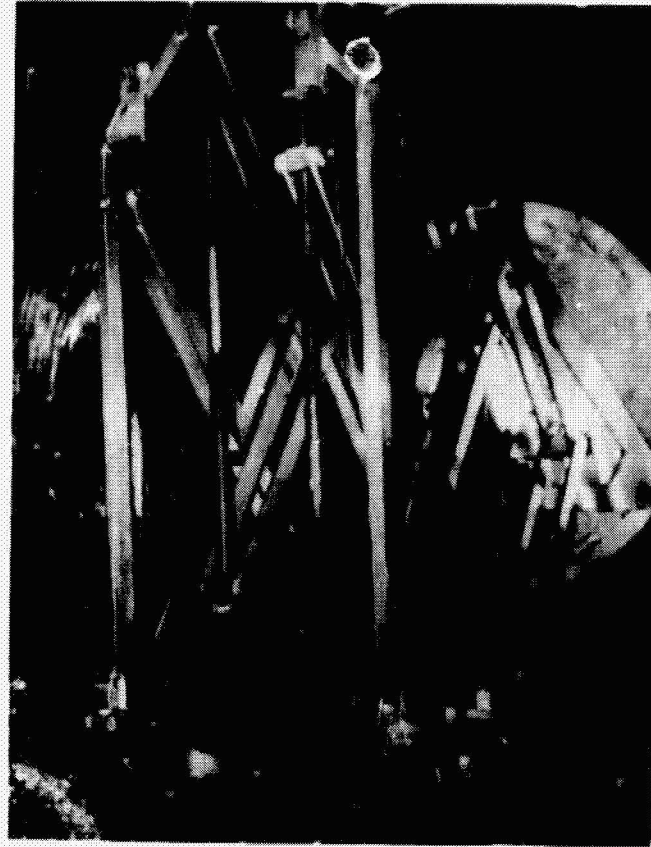
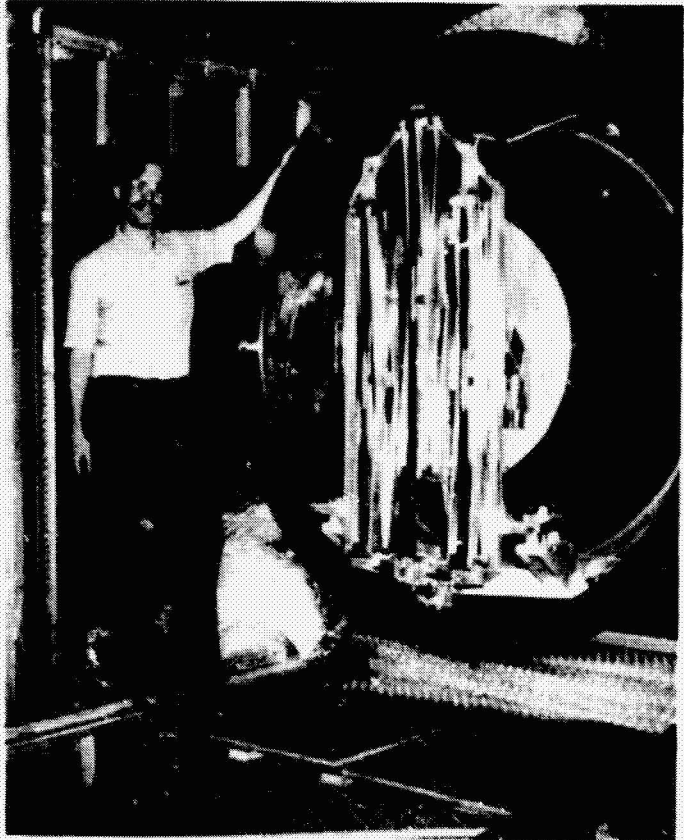

Figure 3. Flexible Cone and Drive

The mean free path between wall collisions of the storage box is given by:⁴

$$d = \frac{4V}{A}$$

where V and A are the storage box volume and area respectively. Thus the wall shift is:⁴

$$\Delta\nu_w = \frac{\varphi}{2\pi} \frac{vA}{4V} = \frac{K}{V}$$

where φ is the phase shift per collision and v is the average atomic speed. This means that, in the two cone positions, the maser frequencies will be:

$$\nu_1 = \nu_0 + \frac{K}{V_1}$$

$$\nu_2 = \nu_0 + \frac{K}{V_2}$$

where ν_0 is the maser frequency without the wall shift. ν_0 is then given by:

$$\nu_0 = \nu_1 - \frac{\nu_2 - \nu_1}{\beta - 1}$$

where

$$\beta^{-1} = \frac{V_2}{V_1}$$

Thus to find ν_0 , one must know the ratio of the storage box volumes for the two cone positions.

Assuming $\beta = 1.5$ and $\Delta\nu_w = 3$ MHz, to obtain a fractional error of 10^{-14} for the wall shift correction one must know β to 0.1 percent. To do this one uses the ideal gas law. If one seals off the storage box when it is filled with a gas and flips the cone, one can determine β from:

$$\beta^{-1} = \frac{V_2}{V_1} = \frac{P_1}{P_2}$$

where P_1 and P_2 refer to the pressure in the storage box in the two cone positions. To do this without distorting or worse bursting the flimsy teflon cone, one uses the system outlined in Figure 4. This system tracks the pressure in the

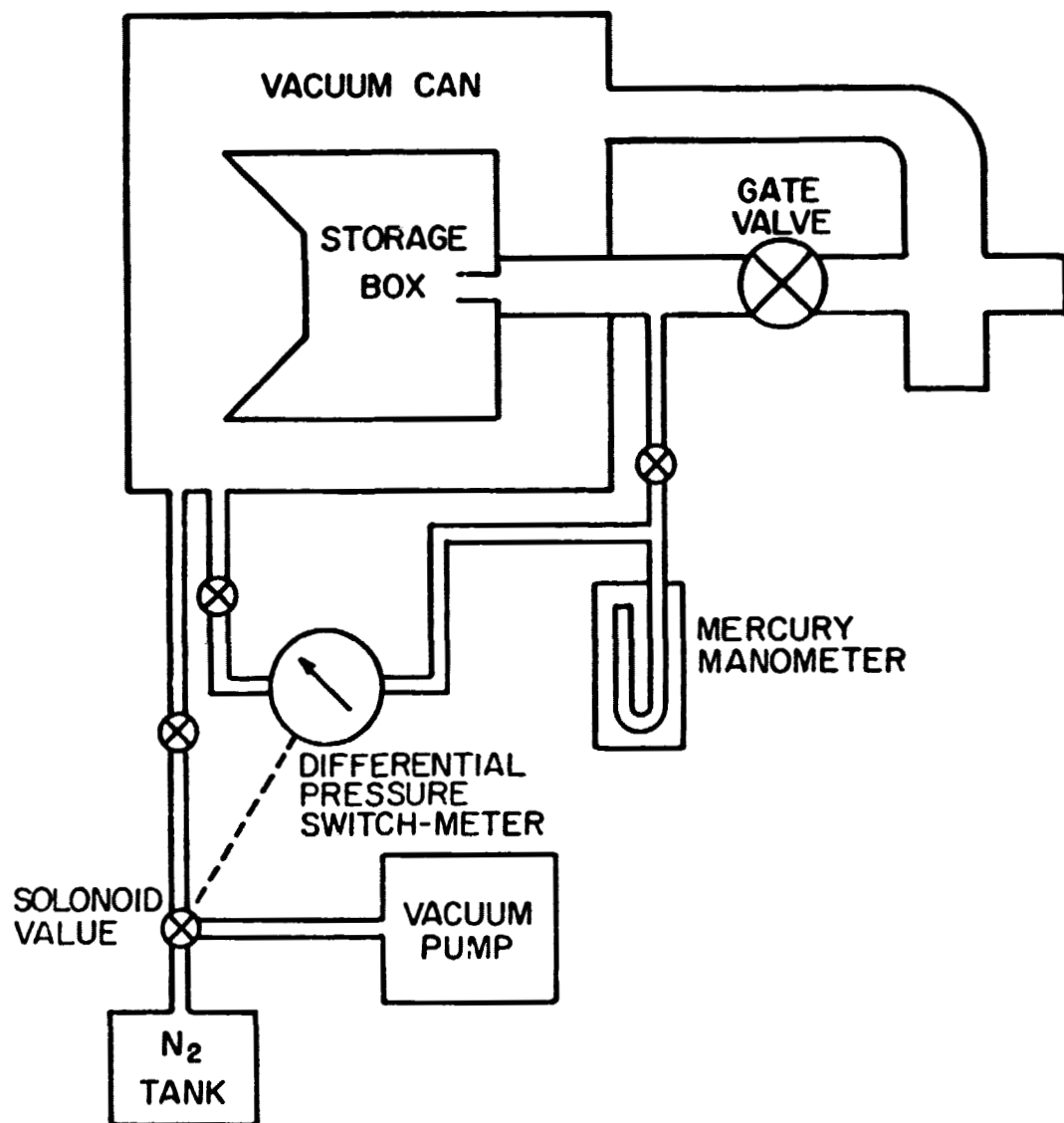

Figure 4. β Measurement System

vacuum can to the storage box pressure while one is flipping the cone. The system is capable of keeping the pressure difference across the cone to within ± 0.5 torr, and has the added advantage of allowing one to perform the measurement even though there are leaks between the storage box and the vacuum can.

RESULTS

A plot of the large box maser's frequency fluctuations versus averaging time is shown in Figure 5. The frequency fluctuation measure used is the two sample Allan variance. Notice that, as predicted, the large box maser's short term noise is much greater than that of an ordinary maser. Unfortunately for the long term performance, I was unable to operate the large maser at a low static magnetic field. Because of the extremely narrow linewidth of the large box maser, the static magnetic field's homogeneity requirements for running at low field are much more critical than for an ordinary maser. Also the magnetic shields in the large box maser, being made of overlapping sheets, were not as good as the shields in an ordinary maser. To get a good tuning factor, the lowest field I was able to operate the maser at was about 10 mOe, or at a Zeeman frequency of 10 kHz. The level portion of the σ vs. τ plot can be explained by the observed fluctuations in the static field. To check this, the frequency fluctuations for an averaging time of about one hundred seconds, was measured as a function of Zeeman frequency. A plot of the results is shown in Figure 6. Notice the strong dependence of the frequency fluctuations on Zeeman frequency. Also affecting long term stability, was the fact that I was forced to run the maser with a cracked storage bulb in one of the microwave cavities because of the inability to get a replacement in time. This crack kept us from clamping the bulb sufficiently tightly, and the frequency of the cavity containing the cracked bulb drifted. Another problem was caused by a lack of enough pumping speed in the titanium sublimation pump that pumped on the source. This caused the tuning factor to decay as one ran the maser at high flux.

To compensate for these problems data was taken in the following manner. First the tuning factor of the maser standard the large box maser was being measured against was determined. Then several data runs were taken in which each data run consisted of the following sequence of frequency comparisons:

- a. 1BL - 1ML
- b. 1BL - 1MH
- c. 2BL - 1MH
- d. 2BH - 1MH

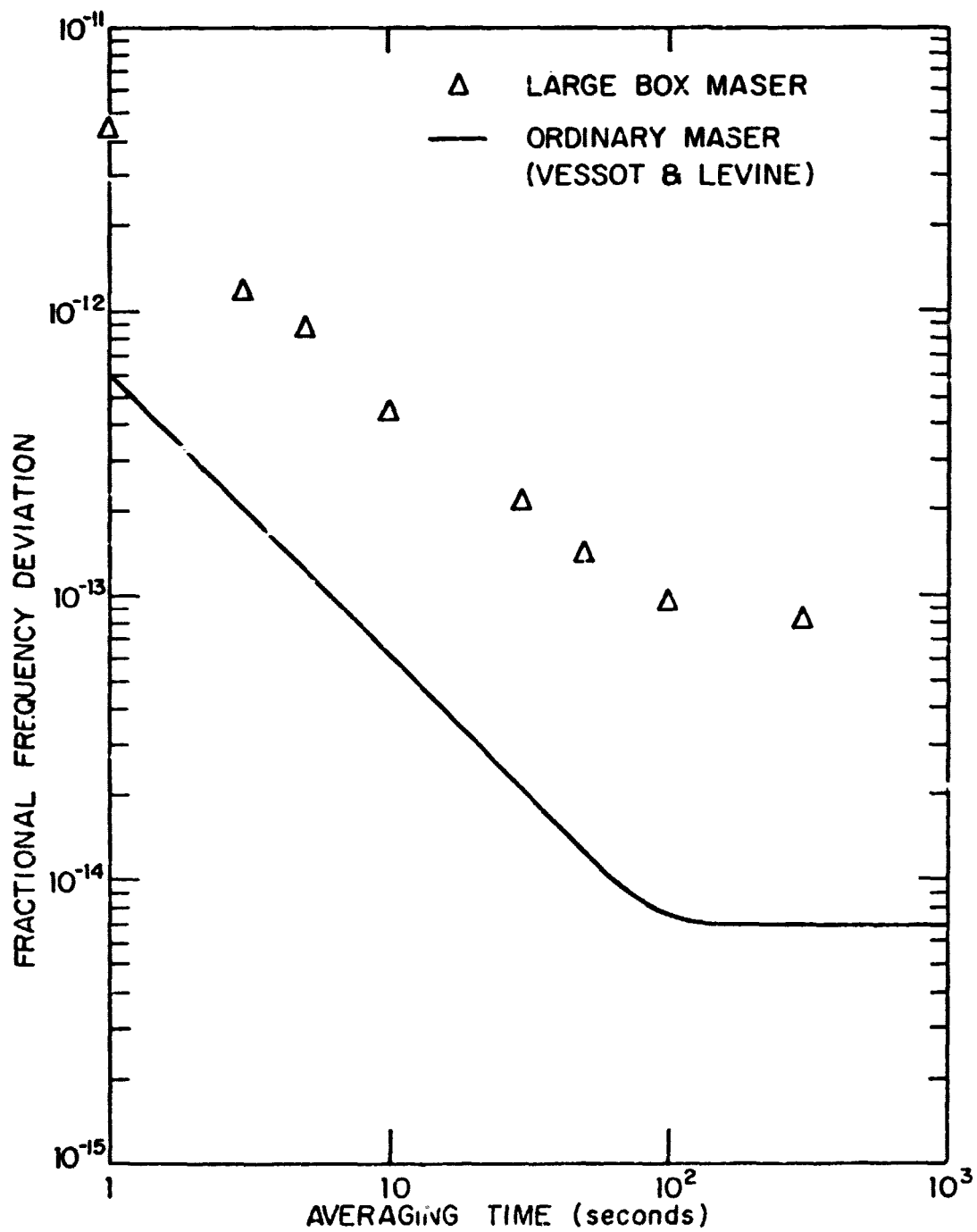

Figure 5. Fractional Frequency Deviations of Large Storage Box Maser (cone out, low flux, $\nu_2 = 15$ kHz)

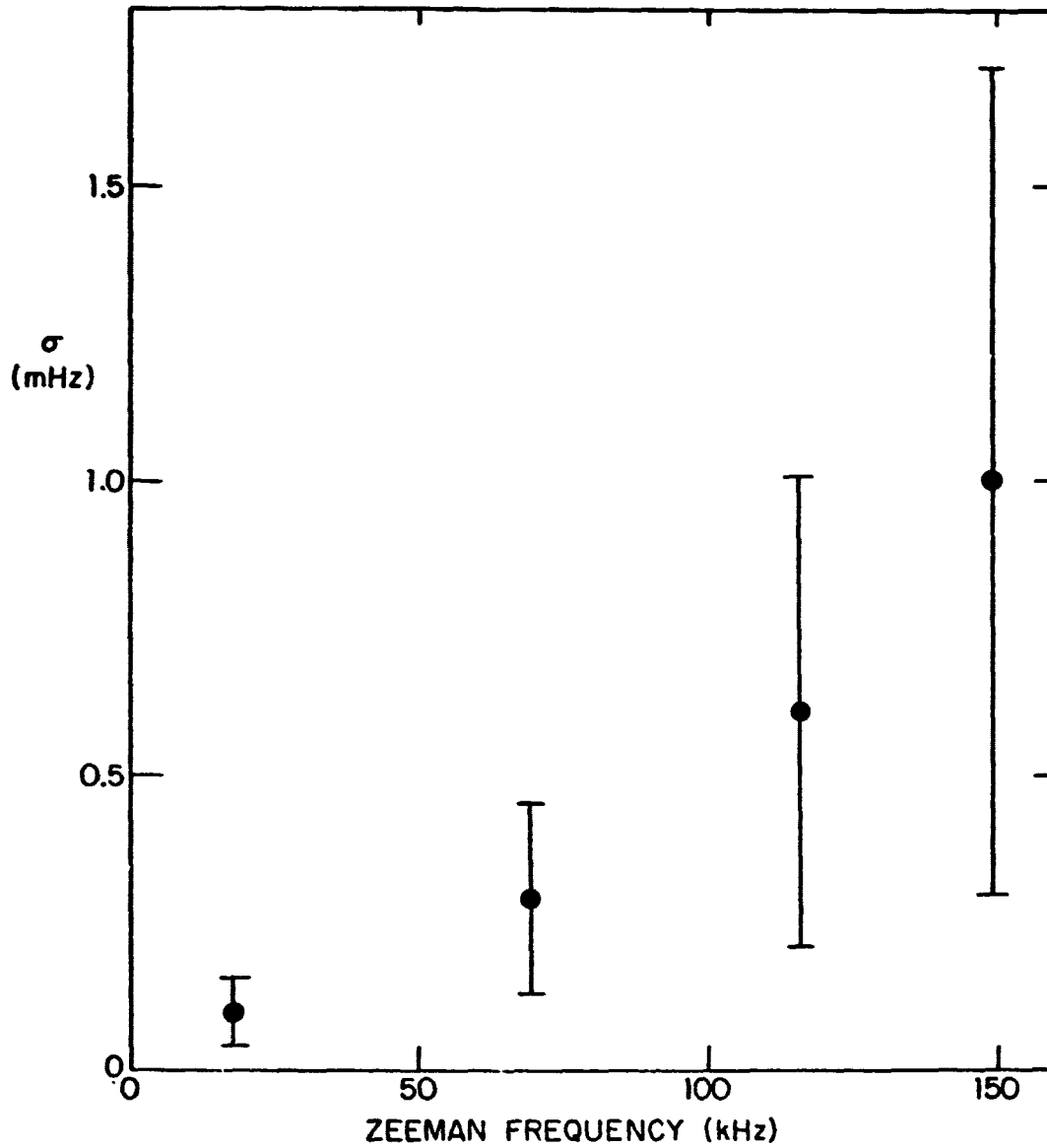

Figure 6. Frequency Fluctuations (~ 100 sec av) vs. Zeeman Frequency

e. 1BH - 1MH

f. 2BH - 1MH

where 1 stands for a tuned maser, 2 stands for a detuned maser, H stands for high flux, L stands for low flux, B for the large box maser, and M for the standard. Between each run there was a dead time waiting for the source pump to

recover. After the runs, the standard's tuning factor was again measured. Also the Zeeman frequency of all the masers was measured before and after the data runs. To analyze the data, the tuning factors of the masers were computed and a series of corrected frequency differences for the two masers were calculated. In order to correct for drifts, for each corrected frequency, the average of the high flux measurements before and after a low flux measurement was used. The mean and variance for the corrected frequencies was then computed. Figure 7 shows a sample data run. FOB - FOM stands for the corrected frequency difference. Notice how the corrected frequencies don't drift even though the individual measurements do. With all the errors folded in, the average error for a six run data set is about 0.5 MHz. This means that for about 30 such sets, or two weeks of data taking, one can correct the maser frequency for the wall shift with an error of about two parts in 10^{13} .

The β measurement system worked as planned. But due to a fairly large leak between the storage box and the vacuum can, probably caused by the cracked bulb, the accuracy of the β measurement was limited to 1.3%. This adds another error of 0.14 MHz to the wall shift correction. The errors in the wall shift measurement, as well as some parameters for the large box maser, are tabulated in Table 1.

CONCLUSION

From Table 1, one can see that the projected error for the wall shift correction is 2.4×10^{-13} of the maser frequency. With the replacement of the cracked storage bulb, the plugging of leaks between the storage box and the vacuum can, and the obtaining of enough pumping speed for the source region, one should be able to reduce the errors even further—easily to less than one part in 10^{13} .

However, Crampton¹² has recently pointed out that two additional shifts can occur in the hydrogen maser, and that these shifts might be as large as one part in 10^{12} of the hyperfine frequency. These shifts are currently being studied.^{11, 12} Until they are understood well enough to be corrected for, they would limit the accuracy of any absolute measurement of the hyperfine frequency of hydrogen.

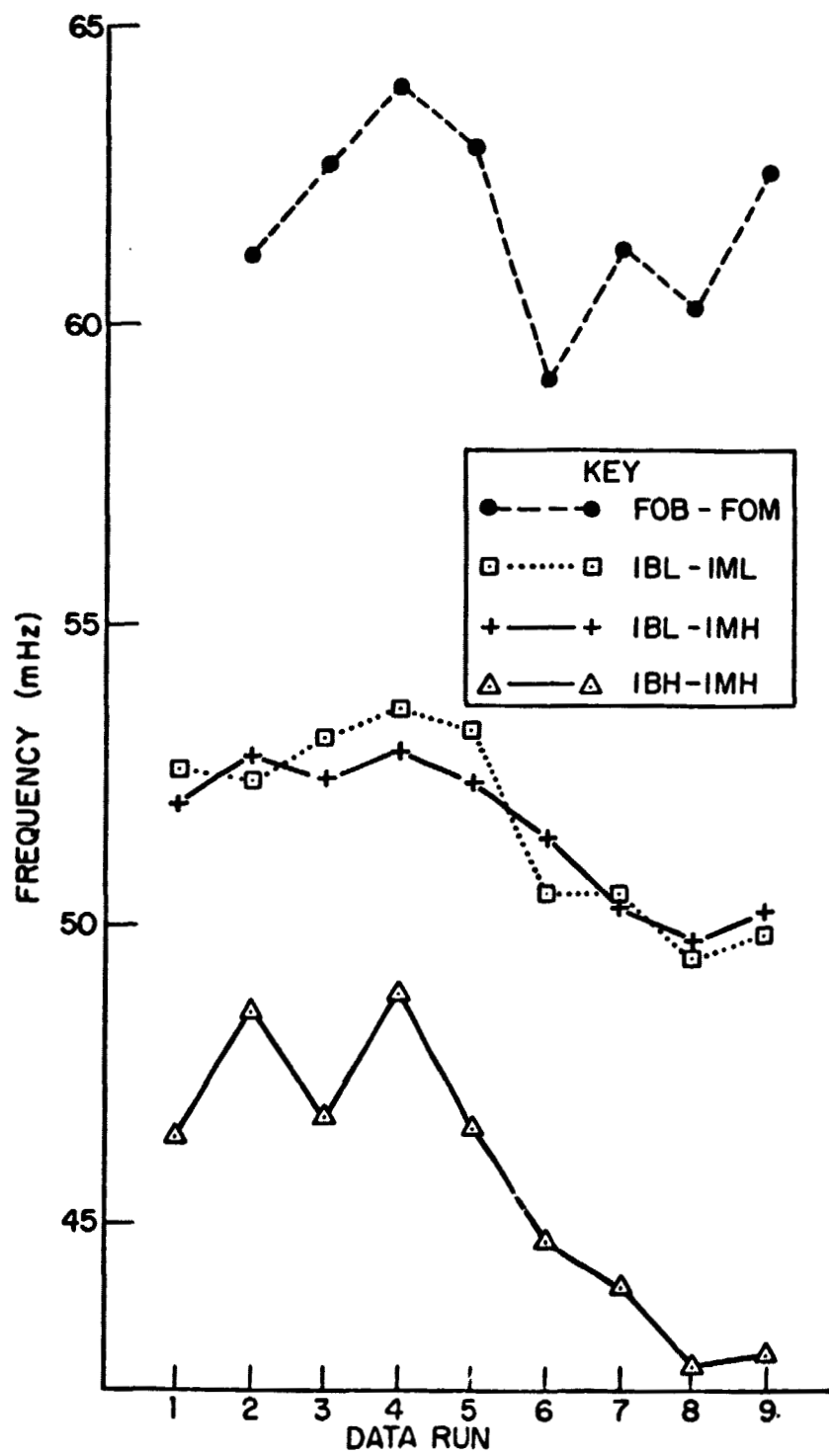

Figure 7. Example of Data

Table 1

<u>Maser Parameters</u>		
$\beta = 1.528 \pm 1.3\%$		
Power out at low flux $\approx 5 \times 10^{-17}$ watts		
$I_{th} \approx 1 \times 10^{13} \text{ sec}^{-1}$		
	Cone In	Cone Out
T_2	2.4 sec	1.6 sec
Wall shift	-5.3 MHz	-3.5 MHz
Tuning factor	1.33	1.5
<u>Wall Shift Measurement Errors</u>		
Source of Error	Error	
Statistical Fluctuations*	0.310 MHz	
$\langle H_z^2 \rangle - \langle H_z \rangle^2$	0.004 MHz	
β measurement	0.143 MHz	
Anomalous spin exchange shift	<0.04 MHz	
Doppler shift	0.02 MHz	
Total error	<u>0.34 MHz</u>	
Fractional error	2.4×10^{-13}	

*Projected error based on 30 data runs.

ACKNOWLEDGEMENTS

The experiment outlined in this paper is being submitted as a doctoral thesis at Harvard University. I would like to thank Professor Norman Ramsey for both the financial and intellectual support I received as well as for the original idea for the experiment. Thanks are also in order for Ed Uzgiris who built the large storage box maser in its original form. Finally I'd like to thank Robert Vessot and Martin Levine from the Smithsonian Astrophysical Observatory for help in the design of the maser standard used in this experiment.

REFERENCES

1. R. Vessot, et al., NBS Special Publication 343, 27 (1971).
2. H. Helwig, et al., IEEE Transactions on Instrumentation and Measurement, IM-19, 200 (1970).
3. H. Berg, Phys. Rev. 137, 1621 (1970).
4. P. Zitzewitz, E. Uzgiris, and N. Ramsey, Rev. Sci. Inst. 41, 81 (1970).
5. P. Zitzewitz and N. Ramsey, Phys. Rev. 3, A51 (1971).
6. E. Uzgiris and N. Ramsey, IEEE J. of Quantum Electronics, QE4, 563 (1968).
7. E. Uzgiris and N. Ramsey, Phys. Rev. 1, A429 (1970).
8. D. Brenner, A.P.S. Bulletin 14, 943 (1969).
9. D. Brenner, J. App. Phys. 41, 2942 (1970).
10. P. Debely, Rev. Sci. Inst. 41, 1290 (1970).
11. For a more detailed description of the operation of the large storage box hydrogen maser, see References 6 and 7.
12. S. Crampton, Williams College, private communication: Research there has indicated an anomalous spin exchange shift in the ordinary maser, as well as a shift which is a function of both the Zeeman frequency and the size of magnetic inhomogeneities.
13. An experiment to measure one of these shifts is also in progress at Harvard University, being performed by D. Larson.

QUESTION AND ANSWER PERIOD

DR. VESSOT:

I am sure there are questions. Where shall we begin? If not, I have plenty of them.

The first thing is a comment.

There are indeed three ways to get rid of the wall shift. One is to make the bulb infinitely large; the other one is to vary it in a completely known way, as you are trying to do; and the other is to run the maser with the bulk whose wall shift is zero, and you can get this by baking the teflon — putting the teflon at the right temperature.

And, of course, how you know that it is zero means that you have to flex it and vary the collision rates until you seek that temperature at which there is no wall shift.

The thing to be emphasized with this maser is that it has a, something on the order of six times longer storage time than we achieved in, what we would call, the normal masers, which are the ones that are of what I would call passable dimensions about the size of a refrigerator. This is really remarkable. You could live inside it, it is true.

However, there must be some questions of this work. This is quite remarkable in that at last we are getting to the hyperfine separation of hydrogen.

DR. REDER:

Isn't there a fourth way of getting rid of wall shift problems, and that is to buy a cesium standard?

(Laughter.)

DR. VESSOT:

The question is how do you get rid of the wall shift in the hydrogen maser. Of course, your question is correct, you could also buy a Mickey Mouse watch.

The other question, though, is, indeed, there are other ways of doing this, as Mr. Peters no doubt will tell us, and that is to use a beam type approach with hydrogen which he has successfully done.

These are, I think, not techniques that eliminate the wall shift in a maser. However, it is a different approach entirely.

DR. KLEPCZYNSKI:

I did have one question.

Why teflon?

MR. REINHARDT:

Okay. Teflon is not unique, but the best of the materials that have been found. When the hydrogen atom makes a collision with the wall surface, you don't want any free spins around, or any hydrogen around, and the teflon structure has no free spins. It is a carbon spine with tightly bound chlorine on the outside, and you get no spin exchange collision, so there is no great phase shift due to a spin exchange effect.

The effects, the relaxation and frequency shift effects have been pretty much explained in terms of just a slight perturbation of the potential and on spin dependent perturbation, due to the distorting of electron cloud physically; when the atom collides into the wall, there is quite a small effect. If you put in any material that will spin exchange with hydrogen, you just can't get any bounces.

To give you an idea of how small the interaction with the surface is, it takes 10 to the 4th bounces or more with a teflon surface to relax the atom.

If you put in quartz, you have 100 bounces. If you put in a metal, maybe three or four.

DR. HELWIG:

I just have to comment, the wall shift is such that if you look at the hydrogen maser as a clock, the wall shift is not really of primary concern. The wall shift is a concern to the scientist who wants to know the hyperfine separation, and to NBS, and we are concerned about, again, the same question. But if you just look at clocks stable over a very long time period, there are other things to be more concerned about than the wall shift.

MR. REINHARDT:

I think, though, it is a problem because it is not reproducible. If it were reproducible, it would be much less of a problem.

DR. HELWIG:

Again, for a clock which is calibrated or set, it is not the primary problem, because we believe, thanks largely to Harry Peters' work, that over long time periods, there is very little evidence for changes in the wall shift once you have the maser device operating.

DR. VESSOT:

In summary, maybe we could say that it is the difference between accuracy and stability. Accuracy is knowing what you are going to get. Stability is keeping on and continuing to get it. They are both different classes of performance.

C-4