

# NASA TECHNICAL MEMORANDUM

NASA TM X- 64896

## AN ASSESSMENT OF THE INSTRUMENT POINTING SUBSYSTEM (IPS) REQUIREMENTS FOR SPACELAB MISSIONS

By M. E. Nein and P. D. Nicaise  
Program Development

November 1974

**NASA**

*George C. Marshall Space Flight Center  
Marshall Space Flight Center, Alabama*

(NASA-TM-X-64896) AN ASSESSMENT OF THE  
INSTRUMENT POINTING SUBSYSTEMS (IPS)  
REQUIREMENTS FOR SPACELAB MISSIONS (NASA)  
45 P HC \$3.75  
CSCI 22A

G3/12  
Unclas  
03645

N75-12018



1. REPORT NO. NASA TM X- 64896	2. GOVERNMENT ACCESSION NO.	3. RECIPIENT'S CATALOG NO.	
4. TITLE AND SUBTITLE An Assessment of the Instrument Pointing Subsystem (IPS) Requirements for Spacelab Missions		5. REPORT DATE November 1974	6. PERFORMING ORGANIZATION CODE
7. AUTHOR(S) M. E. Nein and P. D. Nicaise	8. PERFORMING ORGANIZATION REPORT #		
9. PERFORMING ORGANIZATION NAME AND ADDRESS  George C. Marshall Space Flight Center Marshall Space Flight Center, Alabama 35812		10. WORK UNIT NO.	11. CONTRACT OR GRANT NO.
12. SPONSORING AGENCY NAME AND ADDRESS  National Aeronautics and Space Administration Washington, D.C. 20546		13. TYPE OF REPORT & PERIOD COVERED  Technical Memorandum	
15. SUPPLEMENTARY NOTES  Prepared by Program Development			
16. ABSTRACT  Instrument Pointing Subsystem requirements for Spacelab missions in solar physics, stellar astronomy, and earth observation are analyzed and design guidelines for fine pointing instrument platforms are presented. The requirements for the platforms are time-phased based on NASA projections of flight mission models and payload scheduling. The experiments used for these projections are to be viewed as representative payloads. Other experiments or experiment groupings within any one discipline may be accommodated by an Instrument Pointing Subsystem that meets these requirements.			
17. KEY WORDS	18. DISTRIBUTION STATEMENT  Unclassified-unlimited  <i>William K Johns</i>		
19. SECURITY CLASSIF. (of this report)  Unclassified	20. SECURITY CLASSIF. (of this page)  Unclassified	21. NO. OF PAGES  43	22. PRICE  NTIS

## PREFACE

The design requirements for Spacelab Instrument Pointing Subsystems contained in this report have been prepared for and coordinated with NASA Headquarters (Dr. G. Sharp, Program Chief, Spacelab Science Payloads; the Physics and Astronomy Program Office, Office of Space Science; and the Office of Applications), representatives of Goddard Space Flight Center, and representatives of Ames Research Center. The contributions of the MSFC Science and Engineering Directorate and the invaluable review comments and suggestions from NASA Headquarters and other NASA centers are gratefully acknowledged.

## TABLE OF CONTENTS

	Page
I. INTRODUCTION .....	1
II. EXPERIMENT ACCOMMODATION REQUIREMENTS .....	2
III. ERROR BUDGET ALLOCATION .....	5
IV. OPERATIONAL REQUIREMENTS .....	6
A. Operational Flexibility .....	6
B. Fluids and Gases .....	7
C. Environmental .....	7
D. Software .....	8
E. Safety .....	8
F. Test .....	8
V. DESIGN GUIDELINES .....	9
A. Disturbances .....	9
B. Weight Constraints .....	9
C. Performance Constraints .....	13
D. Gimbal Arrangement .....	13
E. Thermal Control .....	14
VI. REPRESENTATIVE PAYLOADS .....	14
A. Individual Instruments Specifications .....	14
B. Instrument Groupings and Time Phasing .....	14

**PRECEDING PAGE BLANK NOT FILMED**

## AN ASSESSMENT OF THE INSTRUMENT POINTING SUBSYSTEM (IPS) REQUIREMENTS FOR SPACELAB MISSIONS

### I. INTRODUCTION

The ultimate goal of the Spacelab Attitude Control System (ACS) is to accommodate a broad spectrum of instrument types by providing a number of stability and control functions that greatly exceed the capability of the basic Shuttle ACS. These functions include target acquisition, target tracking through wide gimbal ranges, stabilization, simultaneous pointing to one or more targets, instrument co-alignment, and on-orbit calibration. The experiments will vary widely in size, weight, geometry, and instrument types, and many have not been completely defined. This great diversity of requirements reflects the long term plans of the user community, but it also imposes a heavy burden on ACS design. Therefore, two levels of requirements are proposed for the Instrument Pointing Subsystem (IPS) that are time-phased with the availability of experiments for sortie missions.

The phased approach, as presented in this document, defines the overall, long term set of requirements plus a more limited set based on experiments that are currently scheduled to fly by 1983. The long term requirements should be considered as a goal for the current IPS design to assure a flexible approach that is not overly specialized or limited in growth potential. The short term requirements will permit a design that can be operational for early Spacelab missions and will be acceptable for at least the first years of Shuttle operation.

The requirements in this document will be separated into stellar, solar, and earth looking experiments. The differences in requirements between these areas may permit more specialized and practical IPS designs. Representative payload combinations are identified that can serve as specific test cases for an IPS design. Guidelines are defined for those conditions under which the IPS must meet the performance requirements.

## II. EXPERIMENT ACCOMMODATION REQUIREMENTS

This section defines those requirements that are necessary for the IPS to accommodate the proposed range of sortie instruments. These requirements are a summary of the information presented in Section VI of this report, entitled Representative Payloads. The scheduling of payloads for the interim period is based on projections made from the OSS Mission Plan of August 1974.

Table I represents the requirements for payload carrying capacity and accuracy requirements of the IPS. These requirements are based on the instrument performance given in Table II with errors allocated to the IPS according to the rationale given in Section III. It is possible to correct line-of-sight stability error in pitch and yaw (Table II) within a certain range through the use of image motion compensation internal to the instrument. However, that may require complex and expensive instrument design and may even be impossible for some instruments. Therefore, the IPS design approach must not only be based on meeting the pointing accuracy and stability values of Table I but must attempt to exceed these values where possible within the limitations of technology, total systems performance, and overall cost effectiveness. Table I is divided into a short term group, which includes typical payload sets prior to 1983 and the long term group, which includes additional typical payloads expected after 1983. The requirements of Section VI representing six disciplines are combined into stellar, solar, and earth looking instruments because of the common requirements within those subgroups.

Table I contains two sets of requirements in each pointing category: payload capacity A and payload capacity B. The rationale for payload capacity A requirements is derived as follows. Individual large experiments and common mounted groupings of smaller instruments as reflected in Table III were analyzed from the viewpoints of target pointing direction, stability requirement, simultaneity of operation, mass characteristics, and size. The maximum payload capacities for large single instruments and groupings of common small instruments were compared and a suitable payload capacity to satisfy the single instruments and the common mounted instruments in each time period was determined for each of the three categories of solar, stellar, and earth looking IPS requirements. However, this approach alone would not satisfy the requirements that smaller instruments can be flown individually. For instance, if an opportunity arises to fly an instrument on a mission that is not specifically dedicated to this particular discipline, it may be desirable to provide fine pointing and stabilization without the use of a large IPS. Therefore, payload capacity B was derived to accommodate any single small instrument in a category, such as a coronagraph or a modulation collimator in solar physics.

TABLE I. THREE-SIGMA IPS REQUIREMENTS

Requirements	Units	1980 thru 1983			After 1983			Remarks
		Stellar	Solar	Earth	Stellar	Solar	Earth	
<b>Physical:</b>								Earth pointing instruments will require specialized pointing systems. Commonality with stellar & solar pointing IPS uncertain.
Payload Capacity (A)								
Diameter	m	2 <sup>a)</sup>	1.6	2	3.7	2	18 <sup>b)</sup>	
Length	m	6	7	1.5	9.5	7	18 <sup>b)</sup>	
Mass	kg	3000	1200	1000	5000	1300	1500	
<b>Payload Capacity (B)</b>								
Diameter	m	0.8	0.8	-	0.8	0.8	-	
Length	m	3	4	-	3	4	-	
Mass	kg	400	300	-	400	300	-	
<b>Gimbal Range</b>								
LOS Angle	deg	± 50	± 5	± 70	± 90	± 5	± 70	
Roll Angle	deg	± 90	± 90	-	± 90	± 90	± 90	
<b>Performance:</b>								a) This value is based on cooling with LHe. The use of supercritical He would increase this value to 2.4m. b) Deployed antenna.
Pointing Acc. - LOS	(sec)	± 1	± 1	± 180	± 1	± 1	± 5	
- Roll	(sec)	± 120	± 60	± 360	± 120	± 60	360	
Stability - LOS	(sec)	± 1	± 1	± 1	± 1	± 1	± 1	
- Roll	(sec)	± 20	± 10	± 2	± 20	± 10	± 2	
Gimbal Slew Rate <sup>c)</sup>	deg/min	30	5	90	30	5	90	
Typ. Stability Duration	sec	3600-5400	10-1000	60	3600-5400	10-1000	2700	
<b>Interfaces:</b>								LOS ≡ Line of Sight (Cone half angle) Roll ≡ Angle about instrument LOS
Cryogens	Type	LHe,LH <sub>2</sub> ,LN <sub>2</sub>	None	None	LHe,LH <sub>2</sub> ,LN <sub>2</sub>	None	None	
Electrical Wires	No.	250-300 plus 10 coax	10-20 plus 10 coax	10-20 plus 1 coax	250-300 plus 10 coax	10-20 plus 10 coax	10-20 plus 1 coax	
Electrical Wire Gage	No.	18-22	18	22	18-22	18	22	

The stellar requirements are generally characterized by wide gimbal ranges, long exposure times, low tolerance to contamination, and simultaneous pointing to multiple targets. Target search shall be initiated by ephemeris data inputs that must drive the instrument to within a few degrees of the target. The IPS gimbal readout must have a resolution of about 0.5 deg for coarse acquisition. Star trackers with a sensitivity to seventh order magnitude guide stars will be mounted on the inner gimbal for automatic acquisition and position reference. The alignment and accuracy of the star trackers to the experiments must be adequate to assure acquisition of a target within a 4 arc min field-of-view. Offset pointing will require IPS gimbal repositioning of  $\pm 5$  deg relative to the star tracker reference target. It is required that the inner gimbal have an inertial sensor with a resolution of 0.5 arc sec or better for transition from reference to offset position. Pointing and stability accuracies for offset targets shall be the same as those specified in Table I. Star trackers will be used to maintain the offset (target) position. Manual acquisition and pointing will require an instrument supplied television camera that is boresighted to the individual instrument. Television monitors in the Payload Specialist Station (PSS) and possibly at ground stations will permit manual slewing of the IPS. Provisions shall be made for interfacing these command signals with the IPS computer. Stability of the IPS, even in the manual control mode, will be maintained by the automatic control system. Avoidance of sun or moon crossings is discussed in the software section.

The solar instruments are generally smaller in size than stellar instruments but more individual instruments will be flown per mission. A number of individual instruments will be clustered on a single IPS. Some instruments remain sun centered while others search the surface of the solar disk. The sun centered instruments must be controlled separately from the offset pointing instruments. The former must have the option of driving the IPS with an error signal that is generated internal to the instrument. The latter must be stabilized by an IPS mounted fine sun sensor or correlation tracker. The fine sun sensor must have offset capability of at least  $\pm 1.0$  deg. On-orbit calibration will be required to align the instruments with the sensors. Manual control requirements will be the same as those for the stellar case.

The earth looking instruments include some of large size and unusual geometry, and many require high gimbal rates for tracking earth based targets. The Shuttle will maintain an earth oriented attitude for this group, with the payload bay toward the nadir. Horizon sensors will provide the basic earth reference, but correlation trackers or boresighted television cameras will be necessary for clouds or earth fixed targets. Inertial sensors on the inner gimbal will be required for stability of some earth looking instruments. Manual control requirements will be the same as those for the stellar case.



### III. ERROR BUDGET ALLOCATION

The IPS line-of-sight stability error budget was established from instrument resolution according to the following empirical relationship:

$$\epsilon_{\text{los}} \approx \left[ \frac{K_{\text{imc}}}{\sqrt{A} (\sqrt{C}) F} \right] R_{\text{inst}} ,$$

where

$\epsilon_{\text{los}}$  = acceptable stability error of IPS line-of-sight

$R_{\text{inst}}$  = angular resolution of the instrument

$K_{\text{imc}}$  = image motion compensation (IMC) correction factor (ratio of IMC range to IMC threshold)

$C$  = number of contributors to stability error such as structure and alignment, thermal, wavefront error, etc.

$\frac{R_{\text{inst}}}{F}$  = total error budget

$A$  = number of controlled axes.

This equation is an approximation based on the assumption that the error magnitude will be shared equally by all contributors and will be equal in all three axes. The error budget is taken as about one-third of the resolution of the instrument for instruments where the image quality off-axis was not specified. As an example, a diffraction limited instrument with a resolution of 0.15 sec, three error contributors, and no IMC would require

$$\epsilon_{\text{los}} \approx \left[ \frac{1}{\sqrt{3} \sqrt{3} 3} \right] 0.15 \approx 0.0167 \text{ sec} .$$

However, IMC with a correction factor  $K = 60$  would reduce the IPS requirement to  $\epsilon_{\text{los}} \approx 1 \widehat{\text{sec}}$ .

The IPS roll stability error budget was based on the criterion that image smear at the edge of field would be equivalent to the smear at center of field due to line-of-sight stability. Therefore, the following relationship exists:

$$\epsilon_{\text{roll}} \approx \frac{2\epsilon_{\text{los}}}{\text{FOV}},$$

where

FOV = total field of view of the instrument.

## IV. OPERATIONAL REQUIREMENTS

This section covers the general, operational requirements that are needed to maintain a design philosophy consistent with the Shuttle and Spacelab. Only those items that are unique to the IPS are included in this document. The more general Spacelab requirements will also be applicable to the IPS.

### A. Operational Flexibility

Operational flexibility must be maximized by incorporating modularity and commonality into the design of the IPS hardware. This design approach is absolutely necessary in view of the diversity of individual instruments. Certain IPS subsystems may be reconfigured from mission to mission, even within one discipline. Typical in this respect would be the exchangeability of the optical bench to substitute a different set of experiments without a complete disassembly of the IPS. Geographic location of the instrument developer may require that certain IPS flight articles be furnished to the development center for integration with the experiments. A modular system design also provides an expedient and cost-effective means for system reparability and maintainability between missions.

## B. Fluids and Gases

Many of the scientific instruments require cryogenic cooling of their detectors during operation, and some of the detectors may even require cryogenic temperature during their entire lifetime. Practically all optical instruments will require an active, inert gas purge during launch, prior to experiment operation, and during reentry and landing. The IPS design must therefore be responsive to the design implications of cryogenic fluids and gases on the IPS. Fluids and gases under consideration by the instrument designers include all noble gases plus nitrogen, hydrogen, and filtered dry air. Although fluid mass requirements are not identified as yet, typical maximum usage rates are estimated as follows.

LHe	10 kg/day
He SCr*	25 kg/day
LH <sub>2</sub>	15 kg/day
LN <sub>2</sub>	35 kg/day

## C. Environmental

The contamination produced by the ACS must not significantly increase the normal background level. The experiments will be especially sensitive to any contamination produced by the IPS because of their proximity. Gas bearings shall not exhaust directly into the environment. Conventional bearings shall be treated according to the general Spacelab requirements for exposure to vacuum conditions.

The design of the IPS hardware should be based on the concept of designing out excessive radiation of, and/or susceptibility to, electromagnetic interference (EMI) rather than adopting a "test it and fix it" philosophy. To avoid EMI generation and/or susceptibility, careful attention should be focused on the areas of electrical bonding and shielding and the design of electronic hardware enclosures.

All high voltage circuits, such as star tracker photomultiplier circuits, must be designed to prevent arcing and corona. Packaging designs must be based on circuit operation throughout the critical pressure range. Because of the relatively short duration of the sortie missions it is imperative that component outgassing does not delay experiment operation beyond the time period required for readying the Shuttle and Spacelab systems. Design guidelines are given in MSFC document 50M05189, entitled "High Voltage Design Criteria."

---

\*SCr = Super Critical.

## D. Software

The software must be designed for flexibility of operation and ease of verification. Modular design will facilitate changes to experiment pointing requirements on a mission-to-mission basis. Inflight reprogramming will be required to handle unexpected situations. The software must provide, as a minimum, the following functions in support of the IPS: (1) generate gimbale angle commands in response to ephemeris data inputs, manual control, or sensor error signals, (2) accept data inputs such as Shuttle attitude data and time updates, (3) perform time sequencing and mode switching, and (4) provide redundancy management. The software must also provide special functions in direct support of the experiments. Inadvertent crossings of the earth, moon, or sun must be prohibited for many instruments. Automatic control of sun shades and instrument doors will be required. Slew rate commands shall be shaped to achieve a smooth profile for the torquer drive commands that will minimize disturbances to other instruments. Provision shall be made for automatic slewing and search patterns. IPS commands shall be coordinated with IMC drive commands for those instruments with IMC.

## E. Safety

The mechanical support provisions for the pointing platform(s) and payload equipment in the stowed position must be such that no parts will break free and endanger the crew during Orbiter crash landing loads. The IPS must provide a redundant system for return into the stowed position, or, alternatively, must enable jettison of any equipment deployed outside the Orbiter payload bay dynamic envelope. The interfaces containing the devices for jettisoning payloads or instruments shall be designed such that major damage to jettisoned experiments is avoided in order to allow recovery of high cost items.

## F. Test

Proper mechanical operation of the gimbale system shall be verified during prelaunch tests; therefore it is necessary to make functional tests of the IPS in a 1 "g" environment. Testing shall not be required at full gimbale range. Provisions shall be made for testing the IPS as a "stand-alone" item without payload.

Ground functional tests will be limited to interface and polarity verification once the payload has been installed in the IPS and the Spacelab/IPS has been installed in the cargo bay. Performance testing of the combined IPS and payload shall not be required.

## V. DESIGN GUIDELINES

These informal guidelines are intended to define a typical set of conditions under which the IPS must meet performance requirements. Certain conditions that were found to be a problem for Skylab and those that could be potential problem areas for Spacelab are identified for information only.

### A. Disturbances

Crew motion was found to be the most significant external disturbance during the Skylab missions. Typical crew activity aboard the Skylab is presented in Figures 1 and 2. Figure 1 shows the Skylab body rate gyro outputs in the X and Y axes during the period when the crew was asleep. Figure 2 shows the same outputs during normal crew-awake activity. These rate gyros were located on the Skylab structure which was not under fine pointing control. The activity is typical of what can be expected during a Spacelab flight. Since restraining crew motion is an unrealistic design goal, the IPS should be designed to compensate for this activity. A design profile based on this data plus other measurements made on an aircraft zero "g" flight are shown in Figure 3. A maximum force of 100 N is recommended to represent a typical level of crew activity within the Orbiter or Spacelab.

The vernier control thrusters have a level of 111 N and minimum on-time of 40 msec. The firing frequency is dependent on a number of factors but will typically be about 1 firing every 5 sec with minimum on-time. The Shuttle can operate within a deadband of about  $\pm 0.1$  deg per axis with a limit cycle rate of about  $\pm 0.003$  deg/sec per axis. Non-minimum impulse firings may be used to reduce firing frequency. In this case, limit cycle rates could be about 0.01 deg/sec.

The internal experiment disturbances on Skylab included shutter operation, filter wheel motions, film advance mechanism, airlock door openings, grating operation, and mirror scan motions. Although these disturbances were quite small, they should not be entirely neglected for Spacelab experiments; additionally, it should be considered that fluids may be stored on the instruments or individual instruments may have an offset drive capability relative to a common experiment base.

### B. Weight Constraints

One of the major scientific advantages of Shuttle sortie missions is the large payload capability that will allow a large number of scientific instruments to be flown on one mission. This capability plus frequent instrument changeout

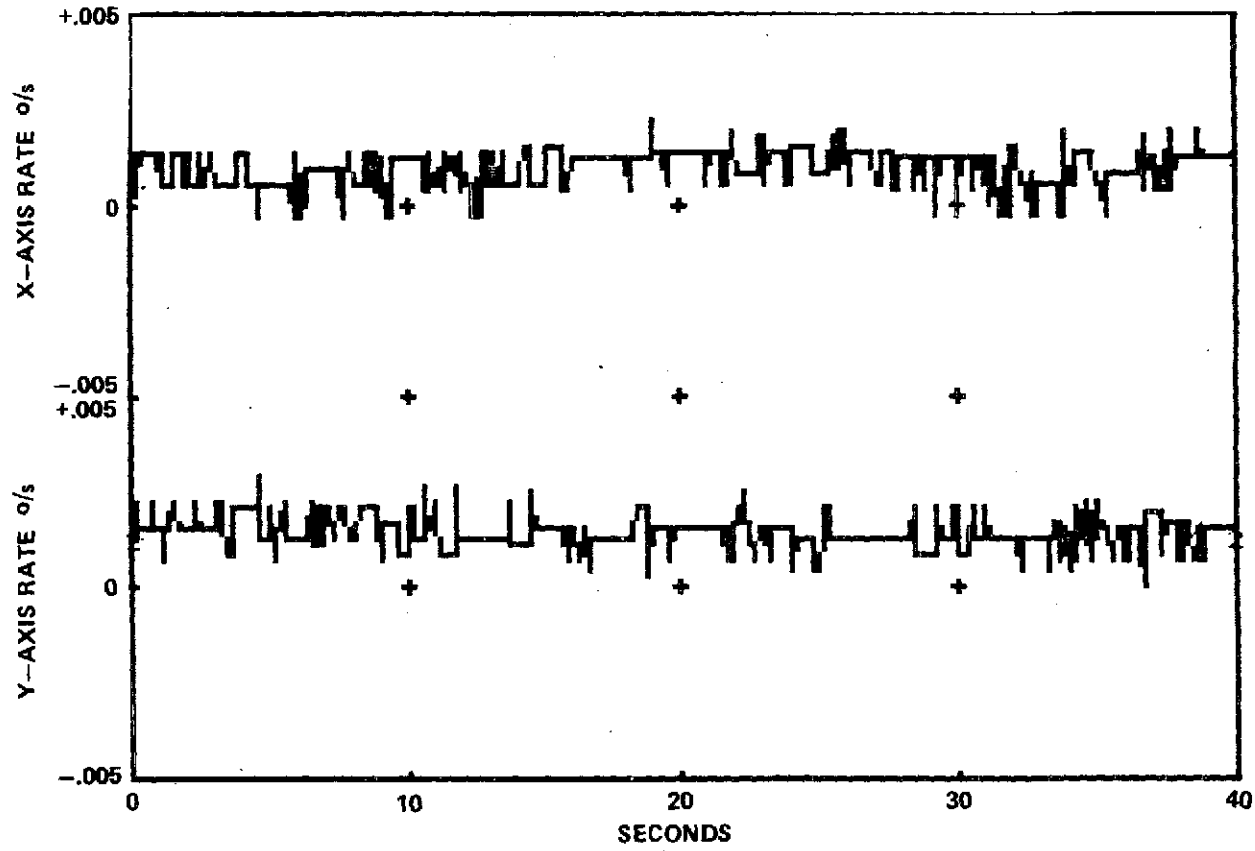

Figure 1. Skylab vehicle rate gyro outputs (crew asleep).

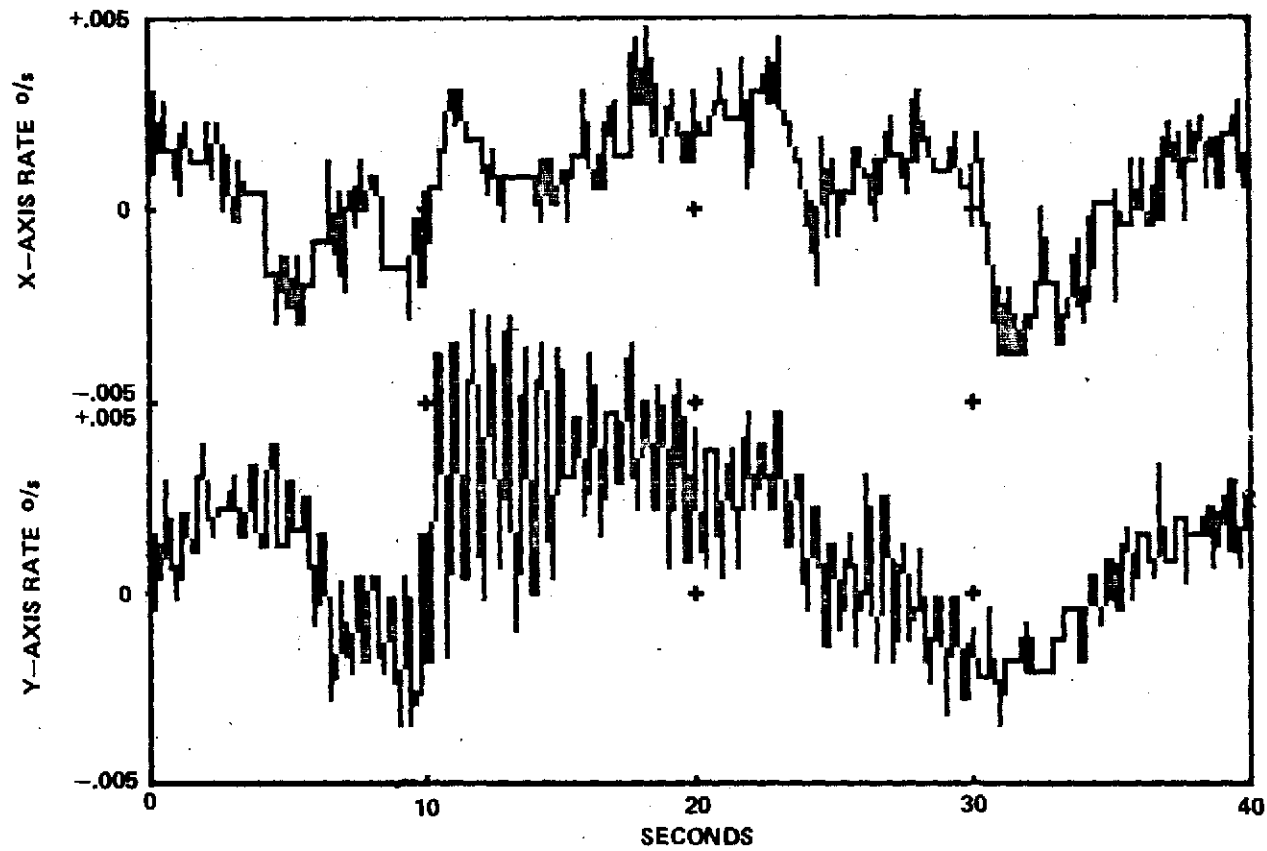

Figure 2. Skylab vehicle rate gyro output (normal crew activity).

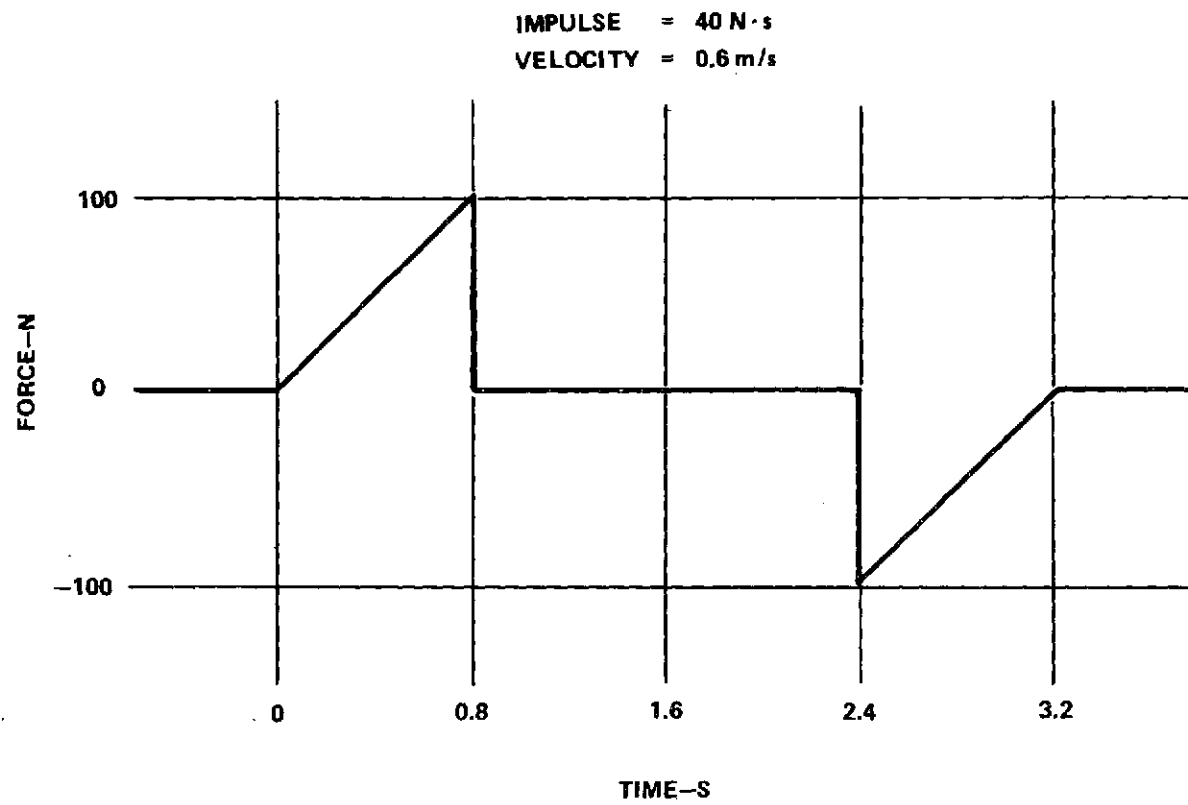

Figure 3. Crew motion design profile.



provides the scientific community with the means for a problem-oriented research approach. Analyses of the scientific requirements for simultaneous operation of a multitude of instruments and the necessary support systems requirements have shown, however, that in many cases the margin between payload weight and Space Shuttle weight carrying capability is narrow. Since the IPS weight contributes significantly to the total system weight, it is of paramount importance that IPS weight control become a major parameter in conceptual development and design.

### C. Performance Constraints

The isolation of disturbances between Skylab and the ATM experiment package was limited primarily by nonlinear characteristics of cabling across the gimbals and the offset between the experiment center of mass and the gimbal axis. A large effort went into minimizing these influences. The cabling work is described in "ATM Wire Torques Across the EPC Gimbal Ring," S&E-ASTR-G-241-70, July 16, 1970. The center of mass of the ATM package was maintained within a close tolerance of about 2 cm by careful measurement. As a result of this work, the isolation of ATM was adequate, but the practical limits of isolation became obvious.

The level of isolation that can be achieved on an IPS was found to be extremely important for high accuracy pointing. For a given level of disturbance, the stability is governed by the response characteristics or bandwidth of the controller. However, the upper limit of bandwidth is typically 2 or 3 Hz because of sensor characteristics, computation rates, or structural stiffness.

### D. Gimbal Arrangement

A particular gimbal order is not absolutely necessary to meet pointing requirements. However, an inner gimbal that permits roll about the instrument line of sight offers some important advantages. This arrangement separates the functions of pointing to the target and alignment of slits or polarimeters on individual instruments. Gimbal angle commands can also be input directly into roll without coupling into the other axes. The roll requirements may be much less stringent than for the other axes or may not exist at all for many experiments. Therefore, this arrangement could allow for an add-on roll capability or a much simpler bearing and drive mechanism on the roll axis. The order of the other two gimbals is somewhat arbitrary, but any arrangement that could result in "gimbal lock" or excessive drive rates should be avoided.

## E. Thermal Control

To maintain various instruments within their respective temperature limits, active thermal control systems will be needed. Because of the conflicting thermal design requirements of various missions, an active thermal control system will allow the payload integrator to accurately specify the thermal interfaces and requirements that must be met by both the carrier and payload. This approach will allow parallel design efforts to be conducted without the constraint of thermal interdependence.

For the stellar pointing instruments the IPS must be capable of accommodating an active thermal control system such as a shroud containing cooling fluid that encloses the telescopes or encloses an optical bench to which several telescopes are mounted.

For the solar pointing instruments which require small gimbals angles only, the active thermal control system may consist of cold wall enclosures surrounding the IPS rather than being integral to the optical bench.

## VI. REPRESENTATIVE PAYLOADS

### A. Individual Instruments Specifications

Table II is a listing of fine pointed instruments which have been proposed by the scientific community in the United States and are endorsed by the NASA Program Offices as representative instruments for Space Shuttle sortie missions. They are extracted from the NASA Payload Data Bank.

Six disciplines contain experiments that require pointing and stabilization of instruments and sensors more demanding than provided by the Space Shuttle Orbiter (0.1 deg): solar physics, astronomy, high energy astrophysics, atmospheric and space physics, earth observation, and earth and ocean physics. Pointing and stability definitions as used throughout this report are shown in Figure 4.

### B. Instrument Groupings and Time Phasing

Table III depicts anticipated typical instrument groupings in the various disciplines in relation to three specific time frames. The early time frame from 1980 through 1983 is represented by instruments and instrument groupings in accordance with the latest (August 1974) NASA mission planning by the Office

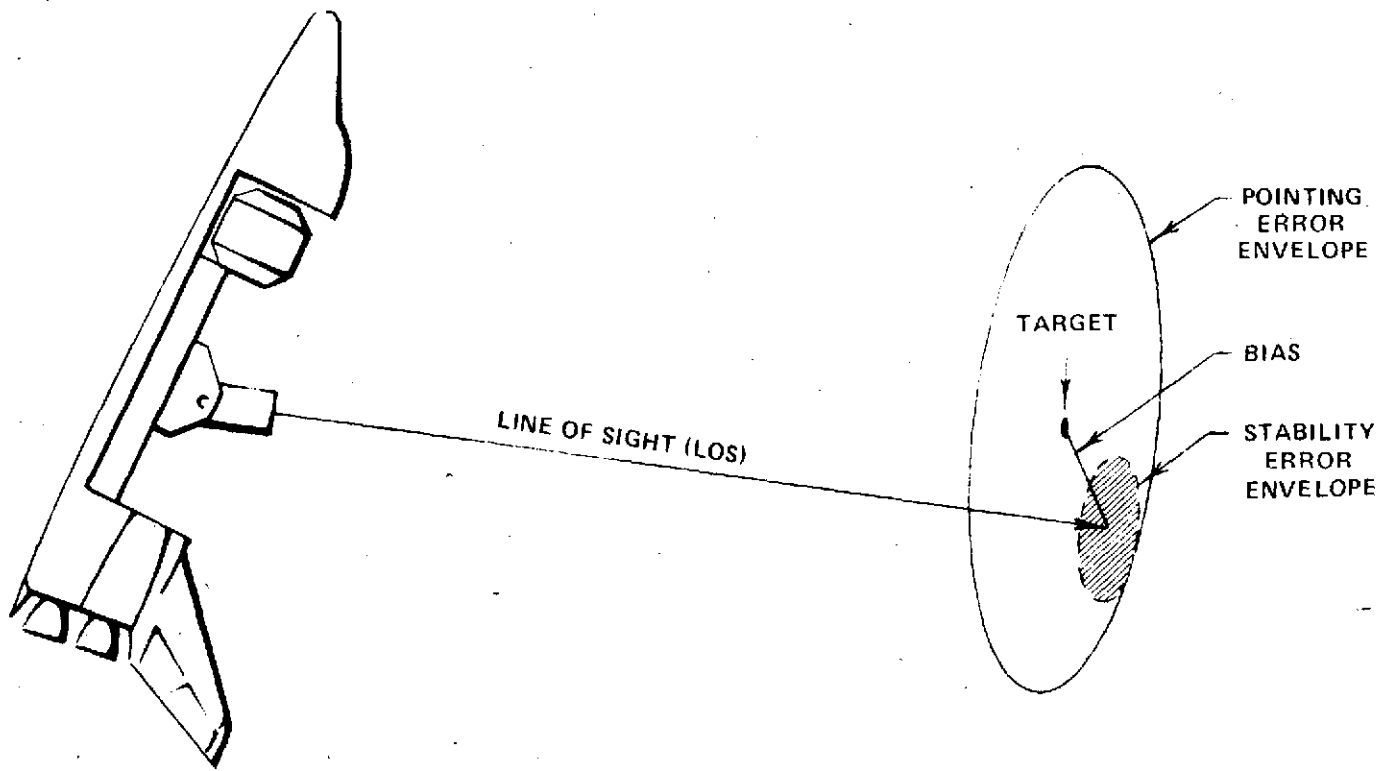

$$\text{POINTING ERROR} \equiv \text{BIAS} + \text{STABILITY ERROR}$$

Figure 4. Pointing and stability definitions.

of Space Sciences (OSS), Office of Application (OA), and Office of Aeronautics and Space Technology (OAST). During this time period experiments will be flown either individually or in combination with other instruments. Typical representative cases in astronomy would be flights of a large (1 m to 1.5 m) cryo-cooled infrared telescope, a 1-m ultraviolet telescope, combined flights of these two systems, and possibly an additional instrument of the rocket-class type payloads on each flight.

The interim time frame of 1984 through 1985 will contain missions that are more ambitious in the instrument groupings. Representative of these missions is the solar physics development of the Solar Telescope Cluster (STC) consisting of several fine pointed instruments that may be flown in different combinations depending on their scientific objectives and development status.

The late time frame beyond 1985 is envisioned as the period during which the full capability of the instrument complements can be realized.

The payload entries in Table III are generated from the recommendations of the scientific working groups and the NASA Program Offices on potential payload combinations. They are to be viewed as representative payloads rather than absolute commitments to specific groupings. Although Table III does not contain all flight experiments identified in Table II, it shows a cross section of typical experiment groupings that are representative in scientific objectives, mass characteristics, and pointing requirements. Other combinations of experiments within any one discipline may be accommodated by IPS designs that meet these requirements. Assessment of these representative instruments and their combinations for various missions led to the IPS requirements summary information in Table I.

TABLE IIa. INSTRUMENTS WITH FINE POINTING REQUIREMENTS  
SOLAR PHYSICS

NO.	INSTRUMENT	DIM (m) L x H x W OR L x D	DRY WEIGHT (Kg)	POWER (w)		FIELD OF VIEW sec		POINTING ACCUR. sec.	SPATIAL RESOL. sec.	ALLOWABLE STABILITY ERROR DUE TO TORQUE DISTURBANCES sec	
				OPR	PK	INST.	TOTAL			P, Y a)	R
	<u>SOLAR PHYSICS</u>										
S001S	Dedicated Solar Sortie Msn		2730								
S0001	o Coronagraph, Ext. Occulted	4.6x.6x.6	(204)	40	100	11,500	11,500	20	4	0.45	16
S0002	o Photoheliograph 100 cm	7.1 x 1.5	(1256)	50	80	180	1,800	10	0.15	0.016	4*
S0003	o Spectrograph, UV	4 x 5 x .5	(250)	50	100	0.5	1,800	10	0.5	0.05	13
S0004	o Spectroheliometer EUV	3.7x.61x.66	(270)	100	120	30	1,800	5	1	0.12	25
S0005	o Spectroheliometer/Spectroheliograph	2 x .4 x 2	(150)	15	20	2.5	1,800	5	2.5	0.27	63
S0020	o Telescope/Soft X-Ray Spectrograph	4 x .5 x .5	(250)	50	110	2	1,800	10	1	0.1	25
S0007	o Spectrometer/Soft X-Ray Spectroheliograph	4 x 1 x .6	(270)	60	100	2	1,800	10	2	0.22	50
S0008	o Photometer, Grid Collimator Acquisition	2x.25 x .25	(30)	5	15	10	7,200	10	2	0.22	13
S0009	o Collimator, Modulation	3.1x0.4x0.2	(50)	10	15	10x1800	7,200	10	2	0.22	13
S0035	o Photoheliograph (65cm)	4.0x1.5x1	(900)	50	80	180	1,800	10	0.25	0.027	6*

NOTES: a) Allocation of Error Budget Assuming no Image Motion Compensation. Instrument Requirement will be Accomplished by IMC  
10 Sec to 15 Min Duration (Typically)  
\* For Sun-Centroid Guiding, Use of Scene Tracker will Relax Requirement to 27 Sec

SUPPLEMENT TO TABLE IIa

S0002 100cm PHOTOHELIOGRAPH

S0035 65 Cm PHOTOHELIOGRAPH IS SIMILIAR CONFIGURATION

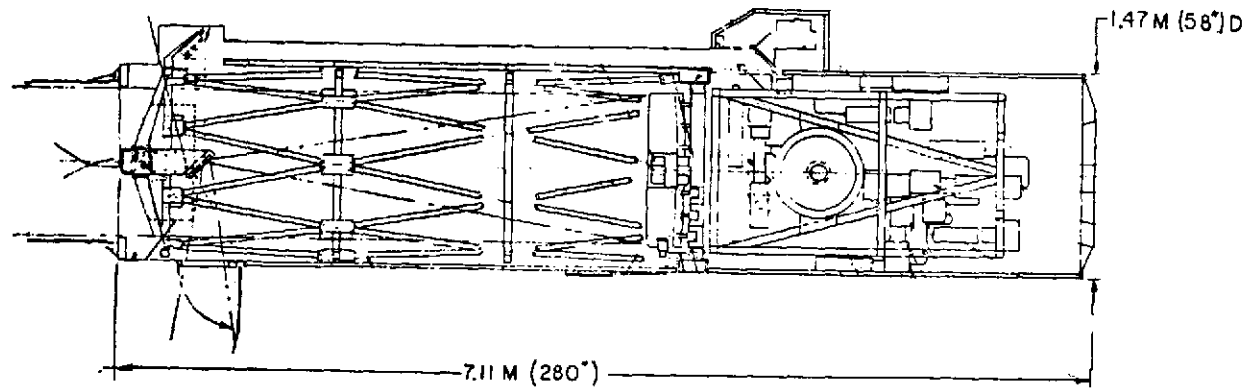

S0 007 SPECTROMETER, 60FT X-RAY/SPECTROHELIOGRAPH

S0 008 PHOTOMETER, GRID COLLIMATOR, ACQUISITION

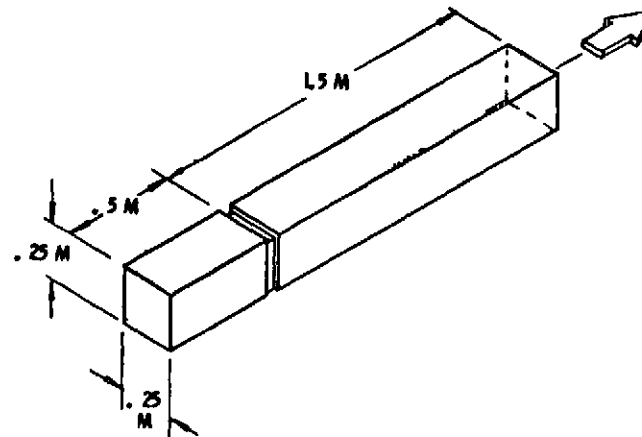
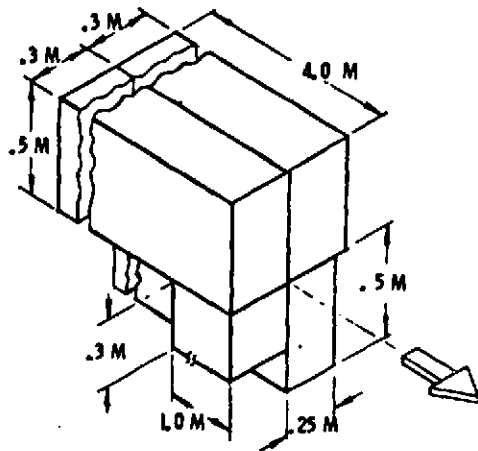

SUPPLEMENT TO TABLE IIa.

S0001 CORONAGRAPH EXT. OCCULTED.

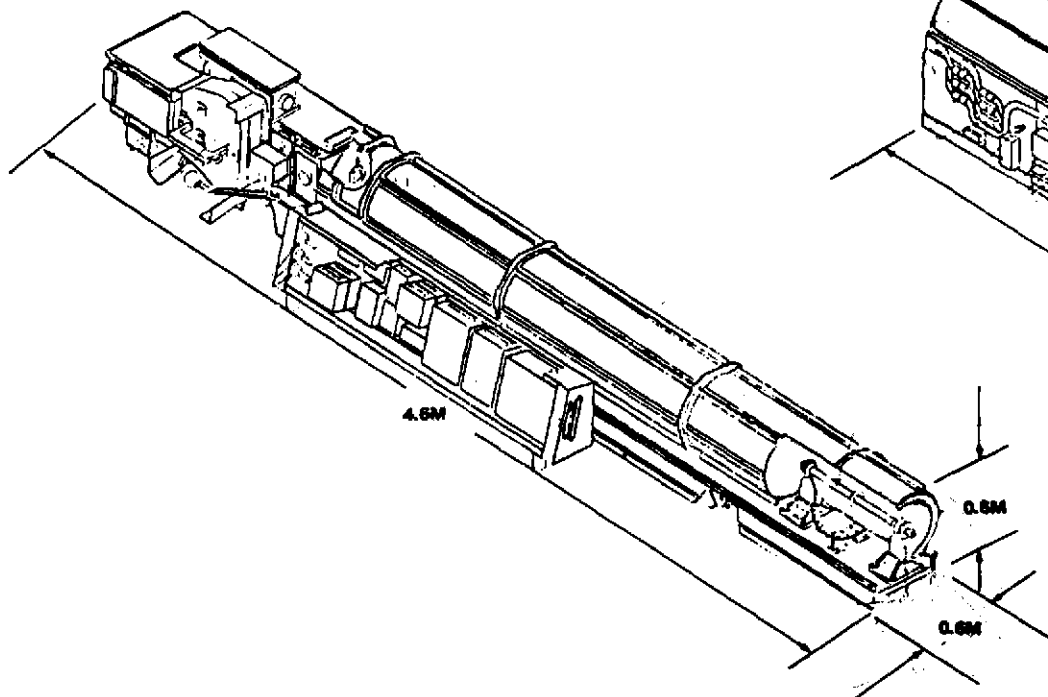

S0003 SPECTROGRAPH U. V.

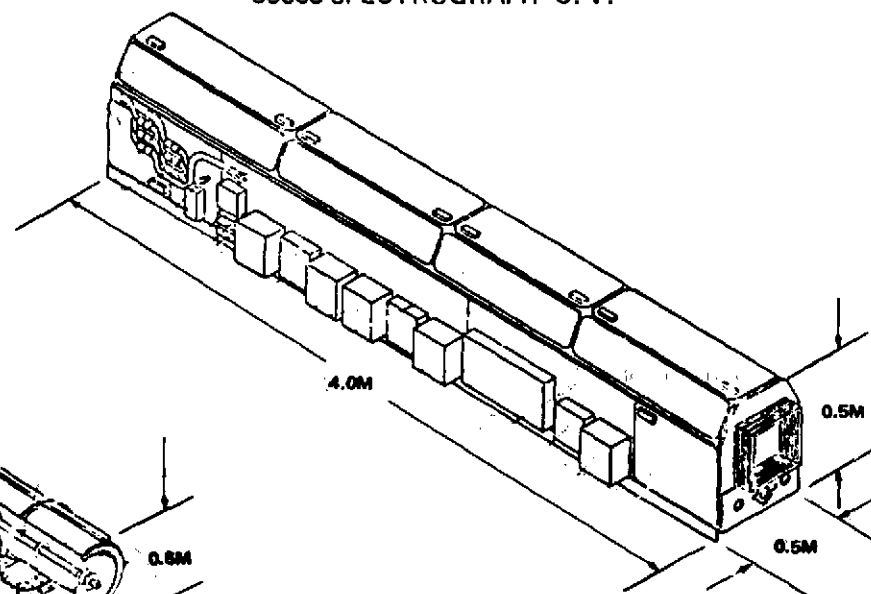

S0004 SPECTROHELIOMETER EXTERNAL U. V. AND S0005 SPECTROMETER/  
SPECTROHELIOGRAPH ARE SIMILAR CONFIGURATION TO S0001 AND S0003

## SUPPLEMENT TO TABLE IIa.

SO 009 COLLIMATOR, MODULATION

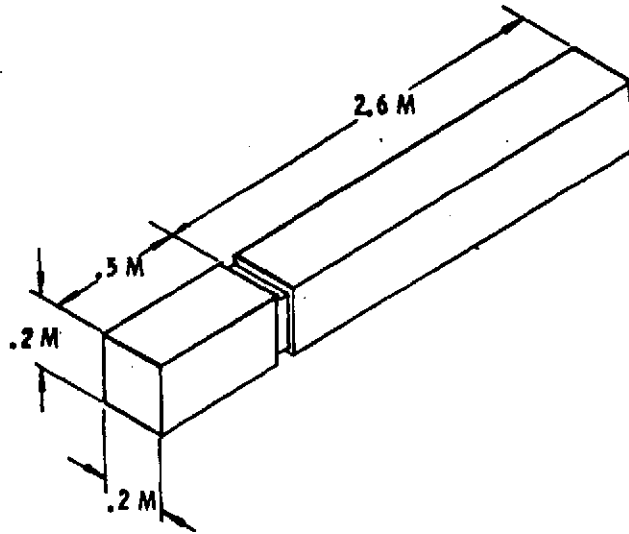

SO020 SOFT X-RAY SPECTROGRAPH TELESCOPE

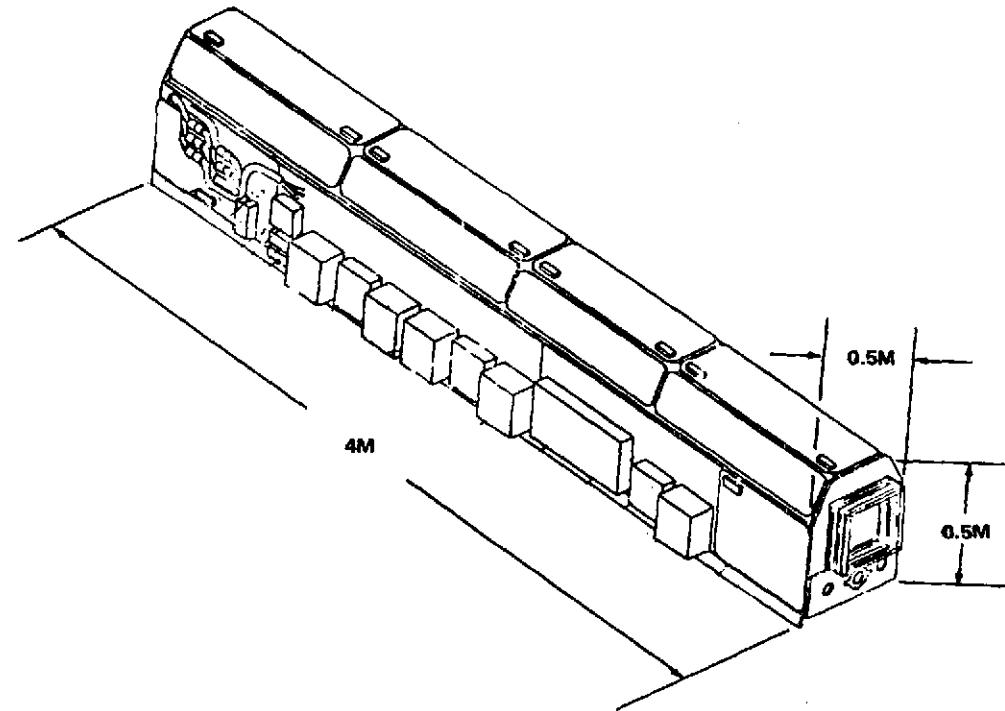



TABLE IIb. INSTRUMENTS WITH FINE POINTING REQUIREMENTS (CONT'D)  
ASTRONOMY

NO.	INSTRUMENT	DIM (m) L x H x W OR L x D	DRY WEIGHT (Kg)	POWER (w)		FIELD OF VIEW ( $\frac{1}{\text{sec}}$ )		POINTING ACCUR. $\frac{1}{\text{sec}}$	SPATIAL RESOL. $\frac{1}{\text{sec}}$	ALLOWABLE STABILITY ERROR DUE TO TORQUE DISTURBANCES $\frac{1}{\text{sec}}$	
				OPR	PK	INST.	TOTAL			P, Y a)	R
	<u>ASTRONOMY</u>										
AS01S	Cryo-Cooled IR o 1.0m IR (Nominal) o Photometer, IR Filter o Array, Detector o Spectrometer, Interferometer o Polarimeter o Spectrometer, Grating o Spectrophotometer	4.0* x 2.4	3000** (2060) (25) (25) (25) (25) (25)	250	300		1800	1	2.5	0.27	63
AS03S	Deep Sky UV Survey o Folded, All Reflective Schmidt (3 Required) o Converter/Intensifier o Film Magazine o Wide Field Aspect Monitor and Tracker	2x2.2x1.2 (each)	3450*** (1130) (27.3) (10) (22.7)	10	30		18000	5	1	0.1	2.5****
AS04S	1m UV Telescope o 1m Dif.Lim. UV Telescope o Spectrograph, Imaging o Spectrograph, Echelle o Spectrograph, Lyman o Cameras, Field	4.0* x 1.8	1266 (1141) (30) (50) (30) (15)	80	140		660	1	0.17	0.019	20

NOTES: \* Plus 2m Sunshield  
 \*\* Includes Cryogen Coolant  
 \*\*\* For All Three Telescopes (Two Might be Acceptable)  
 \*\*\*\* Roll Stability to be Accomplished by Roll Control of Instrument Package Through  $\pm 1^\circ$  Range

TABLE IIIb. INSTRUMENTS WITH FINE POINTING REQUIREMENTS (CONT'D)  
ASTRONOMY

NO.	INSTRUMENT	DIM (m) L x H x W OR L x D	DRY WEIGHT (Kg)	POWER		FIELD OF VIEW		POINTING ACCUR.	SPATIAL RESOL.	ALLOWABLE STABILITY ERROR DUE TO TORQUE DISTURBANCES	
				(w)		sec				sec	
				OPR	PK	INST.	TOTAL	sec.	sec.	P, Y a)	R
AS07S	Cometary Simulation	1.0 x 2.0	454			14,400	14,400	1800	10	1	31
	o Mounting Spar & Canister		(354)								
	o XUV Telescope Filter Photometer		(9.1)	7	14						
	o XUV Telescope Grating Spectrometer		(18.2)	7	14						
	o UV Spectrometer		(6.8)	7	14						
	o Visible Spectrometer		(6.8)	7	14						
	o Near IR Spectrometer		(9.1)	6	12						
	o IR Interferometer Spectrometer		(13.6)	20	40						
	o Far IR Interferometer Spectrometer		(13.3)	20	40						
	o UV Telescope Camera (Carruthers Type)		(15.9)	7	14						
	o TV Camera/Still Camera		(4.1)	20	40						
AS09S	30m IR Interferometer*	15.2 x 0.6 x 0.3	1036	TBD	TBD			1	0.004	0.001*	
	o Extendable Optical Bench		700								
	o 0.5m IR Telescope		(225)	10	20						
	o Interferometer Star Tracker		(40)	30	45						
	o IR Heterodyne Detector		(20)	20							
	o Laser Ref. Carrier		(31)	300	-						
	o Laser Ranging & Signal Receiver		(20)	45	-						

NOTES: \* Two Telescopes Mounted on Booms 30m Apart

TABLE IIb. INSTRUMENTS WITH FINE POINTING REQUIREMENTS (CONT'D)  
ASTRONOMY

NO.	INSTRUMENT	DIM (m) L x H x W OR L x D	DRY WEIGHT (Kg)	POWER (w)		FIELD OF VIEW sec		POINTING ACCUR. sec.	SPATIAL RESOL. sec.	ALLOWABLE STABILITY ERROR DUE TO TORQUE DISTURBANCES sec	
				OPR	PK	INST.	TOTAL			P, Y a)	R
				<u>ASTRONOMY PAYLOAD WITH LIMITED DEFINITION</u>							
AS20S	2.5m Cryo-Cooled IR Tele. o IR Tele. 2.5m Aperture o Broadband IR Filter o IR Photoconductor o Fourier Interferometer o Polarimeter o Grating Spectrometer o Moderate Dispersion Photometer o Instrument Selector Mech.	5.5* x 2.8	3899 (3720) (25) (25) (25) (25) (25) (25) (25)	250	400		1800	10	1	0.11	25
AS05S	Widefield Galactic Camera	-	60	28	80		360,000	1800	-	10	10
AS08S	Multipurpose 0.5m Tele.	1.5 x 0.75	382	100	150		-	2	-	2	-
AS10S	Advanced XUV Telescope	3.0 x 0.5	344	400	450		36,000	1	-	1	11
AS11S	Polarimetric Experiments	2.0 x 0.75	170	300	600		-	2	-	2	-
AS12S	Meteoroid Simulation	2.0 x 1.0	454	1350	1880		-	30	-	10	-
AS14S	1m Uncooled IR Telescope	3.0* x 1.5	1235	500	1000		3600	10	-	1	114
AS15S	3m Ambient IR Telescope	9.5* x 3.7	4995	500	570		1450	5	-	1	285
AS18S	1.5 km IR Interferometer	2.5 x 1.2	1600	1500	1775		1800	1	-	1	230
AS19S	Selected Area Deep Sky Survey Telescope	2.5 x 1.2	890	400	500		11,000	5	-	0.3	11

NOTES: \* Plus 1-2m Sunshield  
\*\* Detector Cryo-Cooling Stored on Telescope

TABLE IIb. INSTRUMENTS WITH FINE POINTING REQUIREMENTS (CONT'D)  
ASTRONOMY

NO.	INSTRUMENT	DIM (m) L x H x W OR L x D	DRY WEIGHT (Kg)	POWER (w)		FIELD OF VIEW sec		POINTING ACCUR. sec.	SPATIAL RESOL. sec.	ALLOWABLE STABILITY ERROR DUE TO TORQUE DISTURBANCES sec	
				OPR	PK	INST.	TOTAL			P, Y a)	R
AS41S	Schwartzschild Camera	1.9 x 0.38	139.5	80	100		-	360	-	1	-
AS42S	Far UV Electronographic Schmidt Camera/Spectro- graph	1.0 x 0.4	110	30	44		36,000	3600	-	10	114
AS43A	UCB Black Brant Payload	2.8 x 0.45	351	140	280		36,000	60	-	2	23
AS44S	XUV Concentrator/Detector	1.7 x 0.45	84	150	200		21,600	100	-	30	572
AS46S	Wisconsin UV Photometry	1.2 x 0.4	68.1	30	50		-	60	-	1	-
AS48S	Aries/Shuttle UV Telescope	3.8 x 1.1	400	250	300		-	1	-	1	-

NOTES: a) Instrument Requirement Will be Accomplished by Image Motion Compensation for P, Y < 1 Sec  
60 to 90 Minutes Duration (Typically)

SUPPLEMENT TO TABLE IIb.

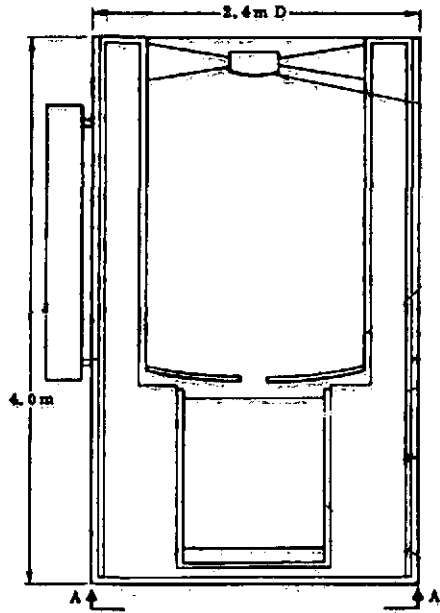

AS01S CRYO-COOLED IR

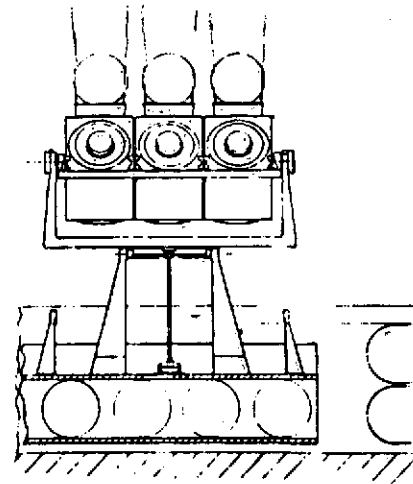
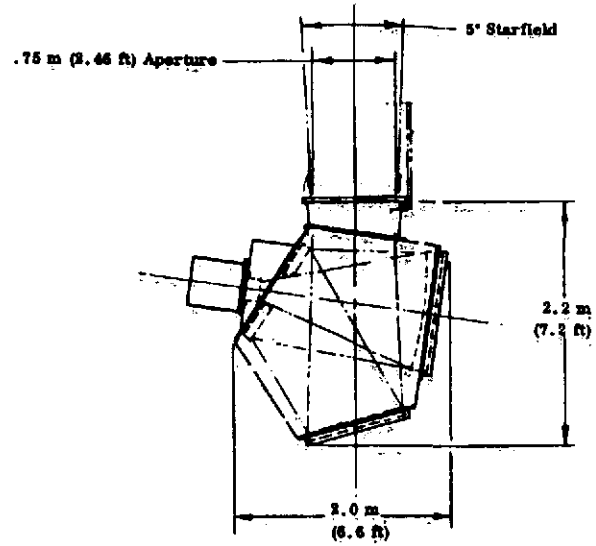

AS03S DEEP SKY U. V. SURVEY

SUPPLEMENT TO TABLE IIb.

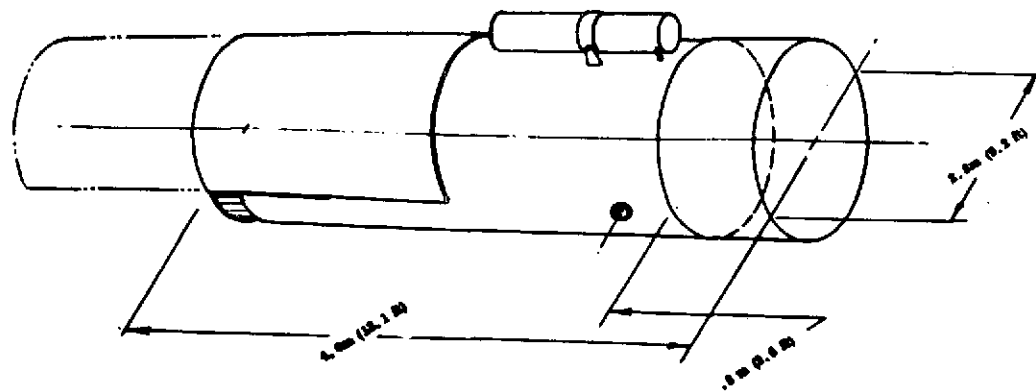
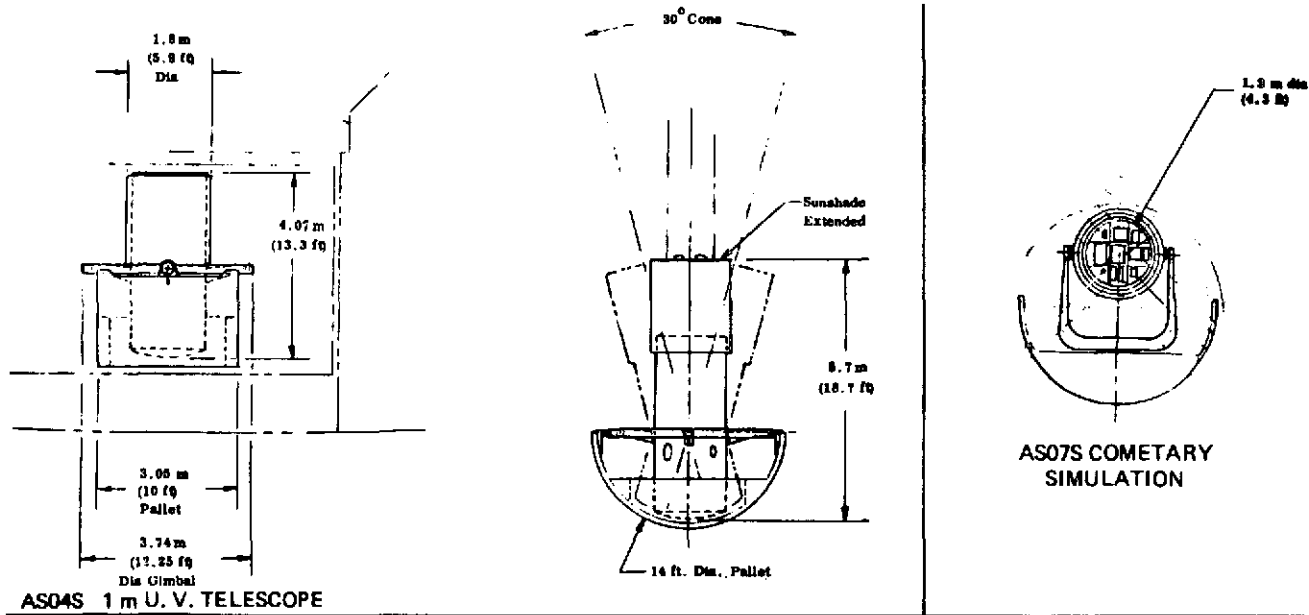

AS020S 2.5 m CRYO-COOLED IR TELESCOPE

SUPPLEMENT TO TABLE IIb.

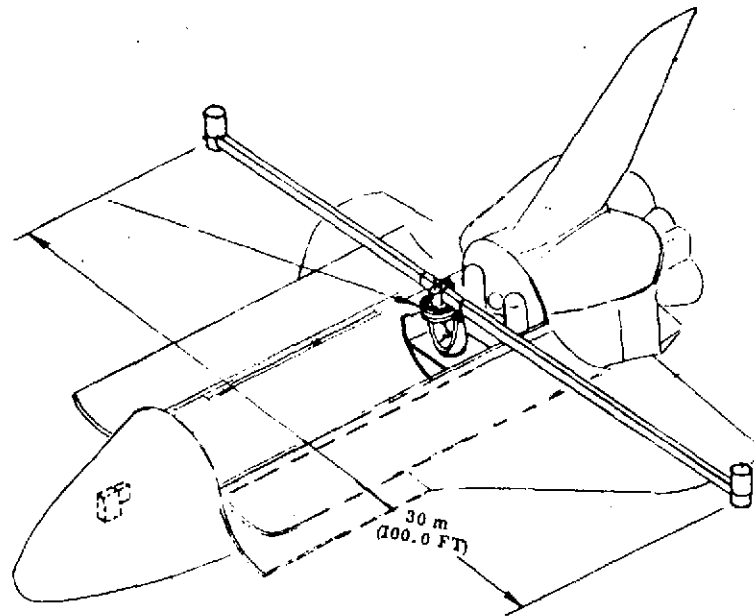

AS09S 30 m IR INTERFEROMETER

TABLE IIc. INSTRUMENTS WITH FINE POINTING REQUIREMENTS  
HIGH ENERGY ASTROPHYSICS

NO.	INSTRUMENT	DIM (m) L x H x W OR L x D	DRY WEIGHT (Kg)	POWER (w)		FIELD OF VIEW ( $\widehat{\text{sec}}$ )		POINTING ACCUR.  $\widehat{\text{sec}}$ .	SPATIAL RESOL.  $\widehat{\text{sec}}$ .	ALLOWABLE STABILITY ERROR DUE TO TORQUE DISTURBANCES ( $\widehat{\text{sec}}$ ) a)	
				CPR	PK	INST.	TOTAL			P, Y b)	R
					<u>HIGH ENERGY ASTROPHYSICS</u>						
HE11S	X-Ray Angular Structure	1.5 x 3.97	4857	37	-						
	o Counter, Proportional Array	4 Systems	(2000)			3,600	60 (Deg)	1	1	N/A	N/A
	o Counter, Scintillation Array	7 Systems	(2800)			18,000	60	1	2	N/A	N/A
	o Optics, Telescope Aspect Sensor		(47.8)			18,000	60	1	1	N/A	N/A
	o Tracker, Field Monitor		(9.1)			-	-	-	-	-	-

NOTES: a) Scanning Instruments; No Stability Requirements. Pointing Accuracy Assessed Through Star Tracker and Ephemeris Data

b) Scanning Rate Approximately 3.6 Min/Sec



SUPPLEMENT TO TABLE IIc.

X-RAY ANGULAR STRUCTURE HE11S

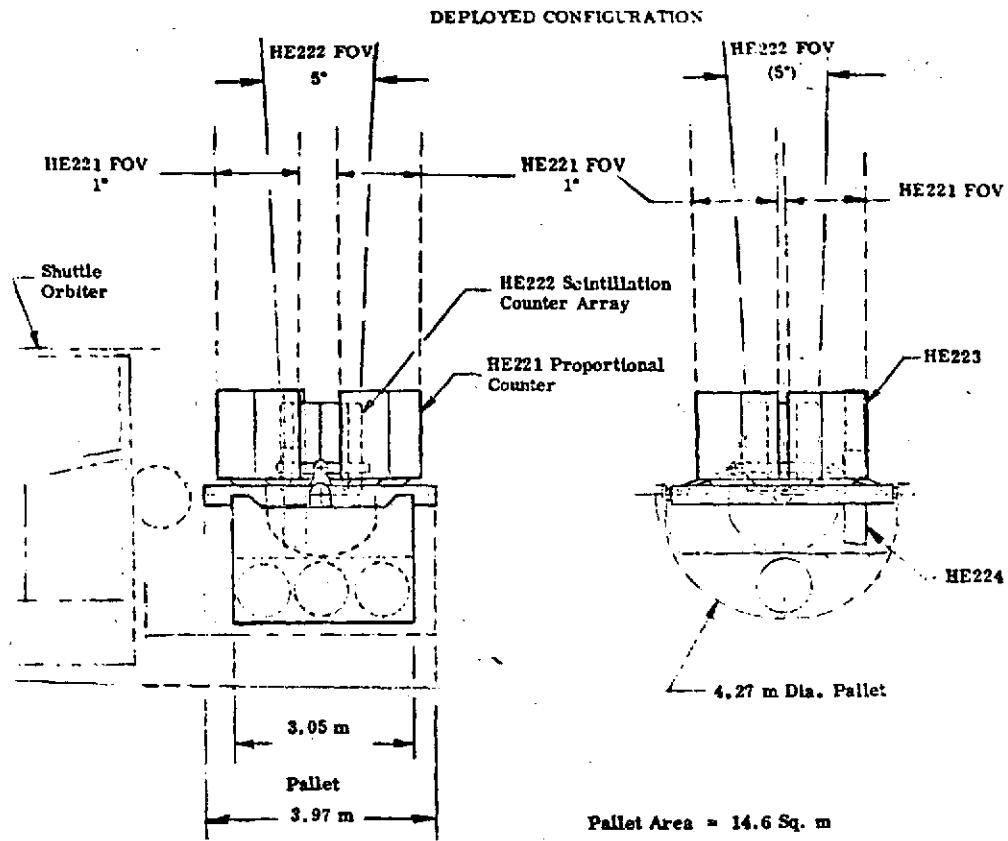

TABLE III. INSTRUMENTS WITH FINE POINTING REQUIREMENTS  
ATMOSPHERIC & SPACE PHYSICS

NO.	INSTRUMENT	DIM (m) L x H x W OR L x D	DRY WEIGHT (Kg)	POWER (w)		FIELD OF VIEW sec		POINTING ACCUR. sec.	SPATIAL RESOL. sec.	ALLOWABLE STABILITY ERROR DUE TO TORQUE DISTURBANCES sec	
				OPR	PK	INST.	TOTAL			P, Y a)	R
AP06S	ATMOSPHERIC & SPACE PHYSICS	1.5 x 1.93	923	200	-	1800	1800	180	2	0.2	50
	Atmospheric, Magnetospheric & Plasmas in Space (AMPS)										

NOTES: a) Instrument Requirement Will be Accomplished by Image Motion Compensation  
30-Minute Duration (Typically)

TABLE IIe. INSTRUMENTS WITH FINE POINTING REQUIREMENTS (CONT'D)  
EARTH OBSERVATIONS

NO.	INSTRUMENT	DIM (m) L x H x W OR L x D	DRY WEIGHT (Kg)	POWER (w)		FIELD OF VIEW sec		POINTING ACCUR. sec.	SPATIAL RESOL. sec.	ALLOWABLE STABILITY ERROR DUE TO TORQUE DISTURBANCES sec	
				OPR	PK	INST.	TOTAL			P, Y	R
	<u>EARTH OBSERVATIONS</u>										
	<u>Baseline System</u>							300 to 1800		50 to 100 Stability	Rate: 50-100 Sec Sec
E0056	Typically: Shuttle Imaging Microwave System (SIMS)	18 x 3.6 x 1	1427	1100	1300	100	30(Deg)	360	100	50	190
	<u>Fine Pointing System</u>							2-10		<< 1 Stability	Rate: << 1 Sec Sec
E0066	Typically: Scanning Spectroradiometer	2.13 x 0.9	202	250		25	29 x 48 (Deg)	5	5	0.3	

SUPPLEMENT TO TABLE IIe

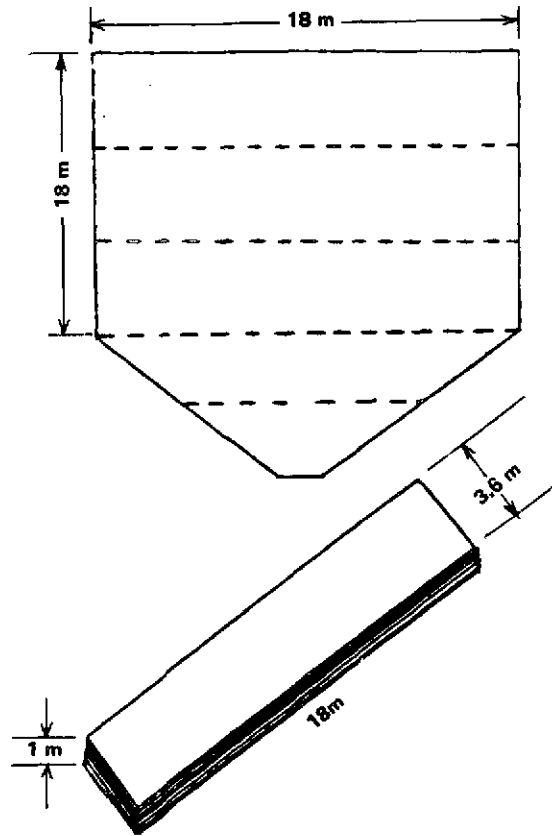

E005S SHUTTLE IMAGING  
MICROWAVE SYSTEM  
(SIMS)

TABLE III. INSTRUMENTS WITH FINE POINTING REQUIREMENTS (CONT'D)  
EARTH AND OCEAN PHYSICS

NO.	INSTRUMENT	DIM (m) L x H x W OR L x D	DRY WEIGHT (Kg)	POWER		FIELD OF VIEW		POINTING ACCUR.	SPATIAL RESOL.	ALLOWABLE STABILITY ERROR DUE TO TORQUE DISTURBANCES	
				(w)		sec				sec	
				OPR	PK	INST.	TOTAL	sec.	sec.	P, Y	R
	<u>EARTH AND OCEAN PHYSICS</u>										
	<u>Baseline System</u>										
	Typically:										
OPO2S	Multifrequency Radar Land Imagery o Antenna o Gimbal & Optical Assy.	0.2 x 3 x10	403	190	-			360	8	1	
OPO3S	Multifrequency Dual Polar- ized Microwave Radiometry	3.0 x 0.77 x 0.4	109.1	133	-			360	2200	0	
OPO5S	Multispectral Scanning Imagery	0.2 x 3 x10	403	190	-			360	5000	0	
OPO6S	Combined Laser Experiment	1.1 x 0.4	141.7	283	-			360	0.2	0.02	
OPOXS	<u>Fine Pointing System</u>	0.7 x 1 x10	400	300		3600	40 Deg	5	<5	<1	

NOTES:

SUPPLEMENT TO TABLE III.

MICROWAVE SCATTEROMETER OP04S

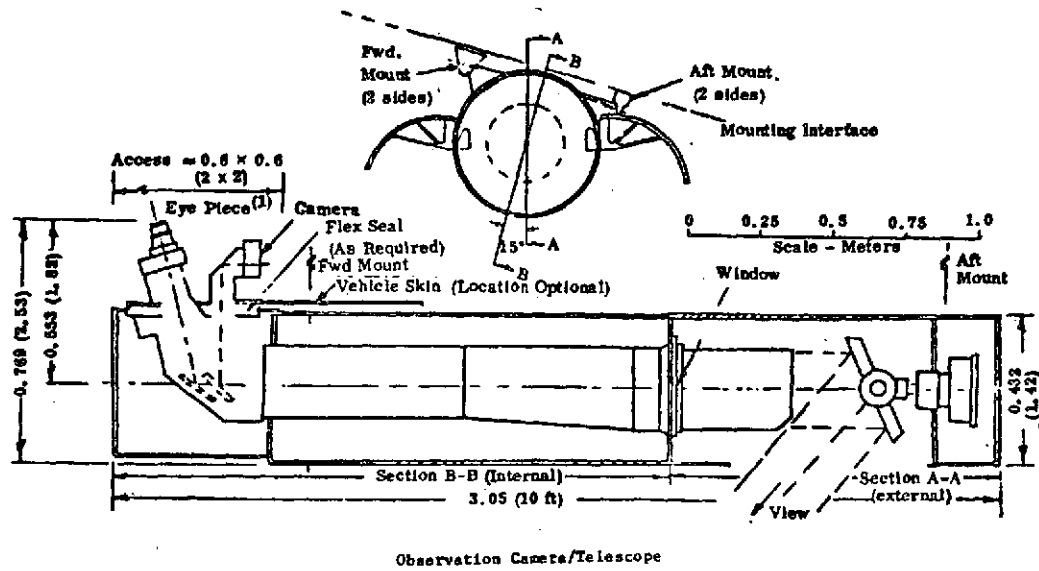

SUPPLEMENT TO TABLE III.

MULTIFREQUENCY RADAR LAND IMAGERY OP02S

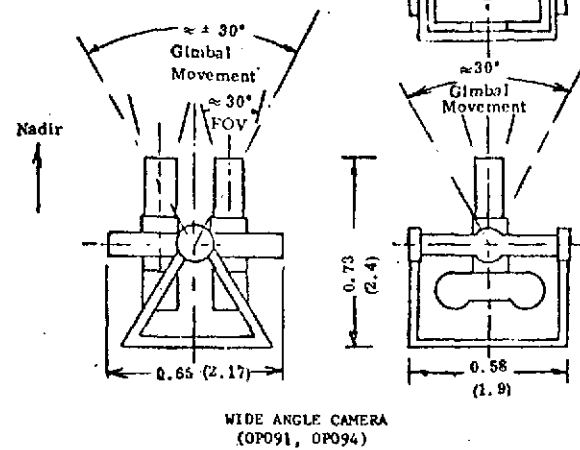
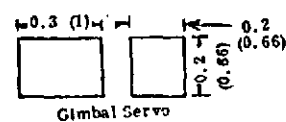
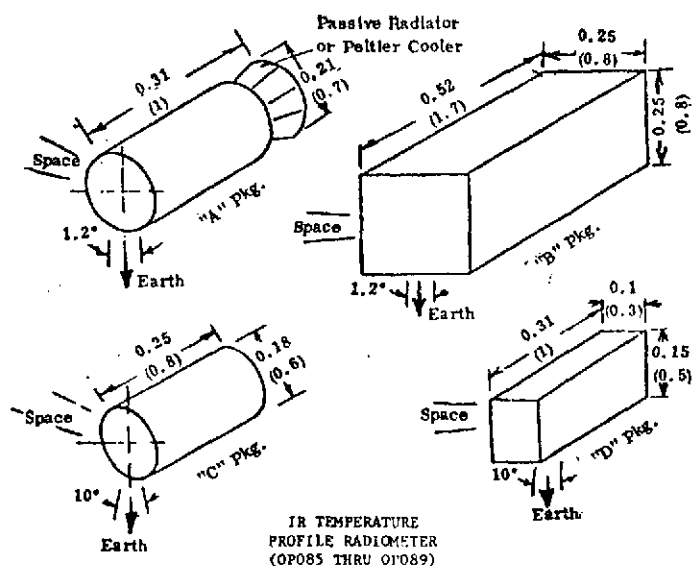

TABLE III. TYPICAL FINE POINTING INSTRUMENT GROUPINGS (TIME PHASED)

YEARS OF SHUTTLE OPERATION SCIENCE CATEGORY	1980-1983	1984-1985	AFTER 1985	REMARKS
SOLAR PHYSICS	(2), (4), (7), (35) (EEX) 2 + (EEX) (RC)	(2) + (1 + 3 + 5) (2) + (7 + 8 + 9 + 20) (2) + (3 + 4 + 20 + 8) + (RC)	(1)+(2)+(3+4+5+7+8+9)	1980-83 includes "quick reaction" expmts for solar max. activity + reflights of single/multiple EEX
ASTRONOMY	(1), (4) (1) + (4) (1) + (4) + (RC)	(1) + (15) + (RC) (4) + (10) + (RC) (3) + (4) + (RC)	(20) + (RC)	RC typically AS 41 through AS 48 of Table II b 4
HIGH ENERGY ASTROPHYSICS	(11)	(11)	(11)	
ATMOSPHERIC & SPACE PHYSICS	(6)	(6)	(6)	
EARTH OBSERVATION	(5)	(5), (6)	(5) + (6)	
EARTH & OCEAN PHYSICS	(2), (5), (6)	(2) + (5) + (6)	(2) + (5) + (6) + (X)	

**KEY**

1,2,3 : Instrument Number As Per NASA Data Bank (SSPD Payload Descriptions, Oct 73 &amp; June 74)

Example: Solar Physics 2 = S0002 of SSPD Payload Description

( ) Denotes IPS

+ Denotes Additional Instruments on Same Mission

RC Rocket-Class Type Instruments

EEX Existing Experiments of ATM-&amp;-OSO Class



SUPPLEMENT TO TABLE III.  
 TYPICAL INSTRUMENT LAYOUT ON  
 1.6m AND 2.0m IPS  
 FOR SOLAR PHYSICS

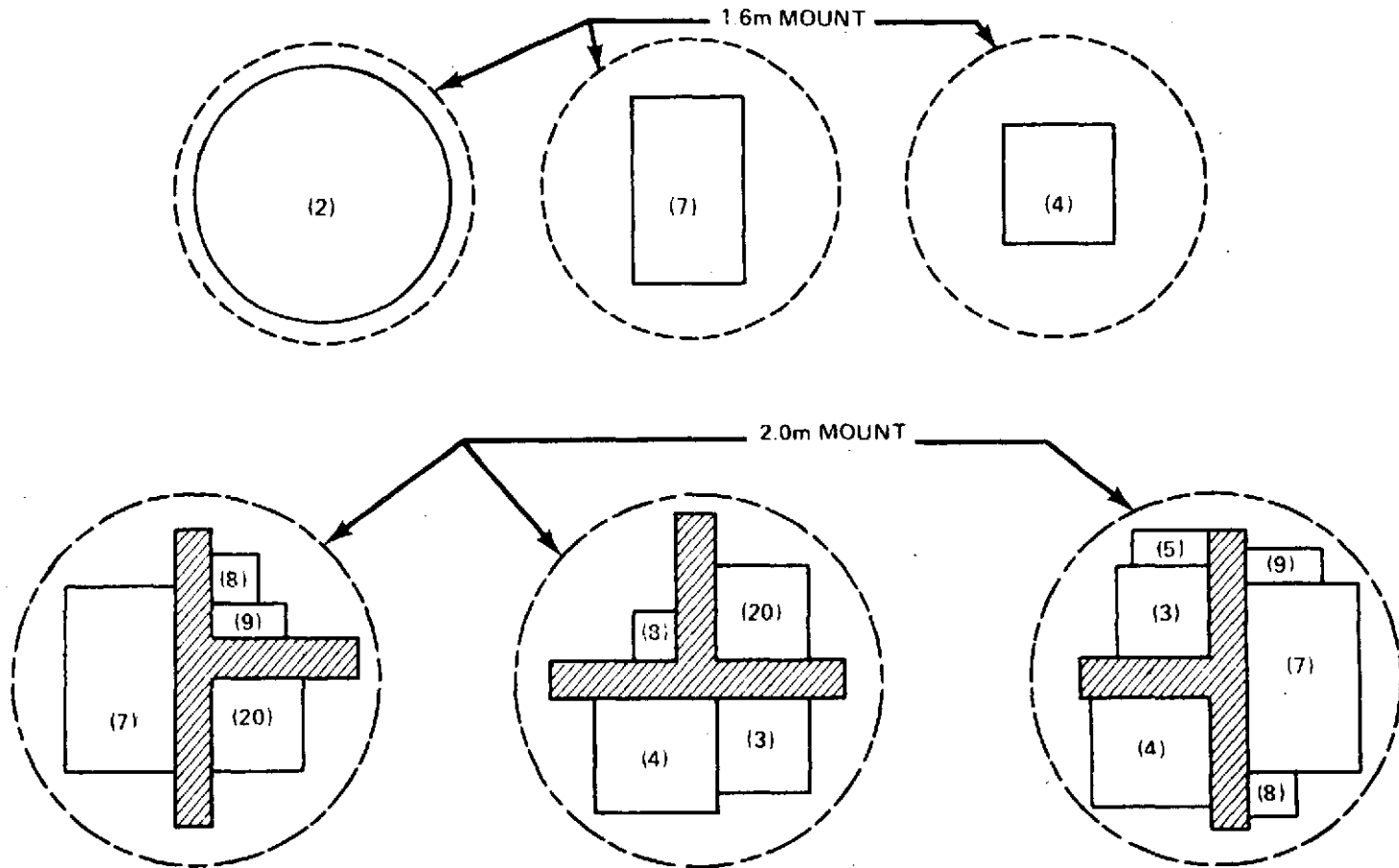

## APPROVAL

### AN ASSESSMENT OF THE INSTRUMENT POINTING SUBSYSTEM (IPS) REQUIREMENTS FOR SPACELAB MISSIONS

By M. E. Nein and P. D. Nicaise

The information in this report has been reviewed for security classification. Review of any information concerning Department of Defense or Atomic Energy Commission programs has been made by the MSFC Security Classification Officer. This report, in its entirety, has been determined to be unclassified.

This document has also been reviewed and approved for technical accuracy.

  
HERMAN P. GIEROW  
Director, Payload Studies Office

  
WILLIAM R. MARSHALL  
Director, Preliminary Design Office

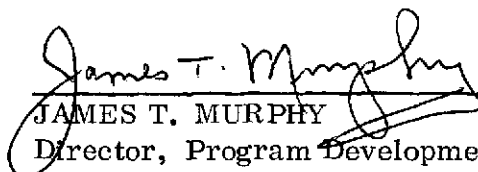
  
JAMES T. MURPHY  
Director, Program Development

INTERNAL

DA01  
W. R. Lucas

DD01  
R. G. Smith

DM01  
J. S. Potate

DS30  
E. Stuhlinger

PA01  
J. T. Murphy  
O. C. Jean  
R. E. Godfrey  
J. A. Downey

EL54  
W. B. Chubb (10)

ES01  
C. A. Lundquist (5)

NA01  
T. J. Lee (10)

EE01  
J. E. Kingsbury

EE41  
Carlos Hagood (10)

EC01  
F. B. Moore

PF05  
C. R. O'Dell

PS01  
H. P. Gierow  
L. T. Spears  
M. E. Nein (20)  
H. G. Craft

PD01  
W. R. Marshall  
F. E. Digesu  
D. N. Schultz  
W. K. Fikes  
P. D. Nicaise (50)  
R. Kozub

GA01  
R. Ise

NA99  
William E. Davidson (10)  
ESTEC-MSFC  
Spacelab Division  
Domeinweg-Noordwijk-Netherlands

CC  
L. D. Wofford, Jr.

AS61 (2)

AS61L (8)

AT01  
J. W. Wiggins (6)

EXTERNAL

NASA Headquarters

MF  
D. R. Lord

MFE  
L. Werner (5)

RE  
P. R. Kurzhals

MK  
P. E. Culbertson

MKP  
G. F. Esenwein (5)

SG  
G. W. Sharp (10)  
A. E. Timothy  
N. G. Roman  
E. R. Schmerling

DRF  
M. A. Calabrese

Goddard Space Flight Center

703.0  
W. Scull

743.B  
F. J. Kull (10)

953.0  
R. M. Waetjen

Ames Research Center

PD  
B. C. Look

PDS  
James P. Murphy (10)

Johnson Space Center

KA  
C. E. Charlesworth

TKS  
R. F. Hergert

CB  
K. G. Henize

Scientific and Technical  
Information Facility (25)  
P.O. Box 33  
College Park, Maryland 20740  
ATTN: NASA Representative (S-AK/RKT)