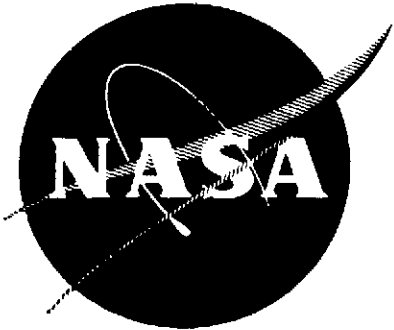


(NASA-CR-134657) NONDESTRUCTIVE TESTS OF N75-12059
REGENERATIVE CHAMBERS, APPENDIX Final
Report (Bell Aerospace Co.) 196 p
HC \$7.00 CSCL 21H Unclas
G3/20 02449

NASA CR-134657
BAC Report No. 8654-953005

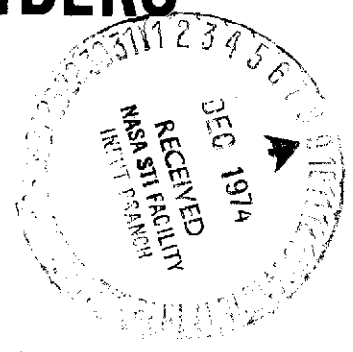


FINAL REPORT APPENDIX

NONDESTRUCTIVE TESTS OF REGENERATIVE CHAMBERS

By

G. A. MALONE
L. VECCHIES
R. WOOD



Prepared For

NATIONAL AERONAUTICS AND SPACE ADMINISTRATION

JUNE 1974

CONTRACT NAS 3-16800

Bell Aerospace Company DIVISION OF **textron**

POST OFFICE BOX ONE • BUFFALO, NEW YORK 14240

NOTICE

This report was prepared as an account of Government-sponsored work. Neither the United States, nor the National Aeronautics and Space Administration (NASA), nor any person acting on behalf of NASA:

- A.) Makes any warranty or representation, expressed or implied, with respect to the accuracy, completeness, or usefulness of the information contained in this report, or that the use of any information, apparatus, method, or process disclosed in this report may not infringe privately-owned rights; or
- B.) Assumes any liabilities with respect to the use of, or for damages resulting from the use of, any information, apparatus, method or process disclosed in this report.

As used above, "person acting on behalf of NASA" includes any employee or contractor of NASA, or employee of such contractor, to the extent that such employee or contractor of NASA or employee of such contractor prepares, disseminates, or provides access to any information pursuant to his employment or contract with NASA, or his employment with such contractor.

1. Report No. NASA CR-134657		2. Government Accession No.		3. Recipient's Catalog No.	
4. Title and Subtitle Nondestructive Tests of Regenerative Chambers - Appendix				5. Report Date June 1974	
				6. Performing Organization Code	
7. Author(s) G. A. Malone, L. Vecchies and R. Wood				8. Performing Organization Report No. BAC 8654-953005	
				10. Work Unit No.	
9. Performing Organization Name and Address Bell Aerospace Company Division of Textron P.O. Box 1 Buffalo, New York 14240				11. Contract or Grant No. NAS 3-16800	
				13. Type of Report and Period Covered Contractor Report	
12. Sponsoring Agency Name and Address National Aeronautics and Space Administration Washington, D.C. 20546				14. Sponsoring Agency Code	
15. Supplementary Notes Project Manager, Rudolph A. Duscha, Chemical and Nuclear Rocket Procurement Section, NASA Lewis Research Center, Cleveland, Ohio					
16. Abstract <p>The objective of this program was to define the capabilities and limitations of nondestructive evaluation methods to detect and locate bond deficiencies in regeneratively cooled thrust chambers for rocket engines. Nondestructive evaluation methods used were those of demonstrated capability from previous work under Contract NAS 3-14376 (NASA Report CR-120980).</p> <p>Under this contract, flat test panels and a cylinder were produced to simulate regeneratively cooled thrust chamber walls. Planned defects with various bond integrities were produced in the panels to evaluate the sensitivity, accuracy, and limitations of nondestructive methods to define and locate bond anomalies. Holography, acoustic emission, and ultrasonic "C" scan were found to yield sufficient data to discern bond quality when used in combination and in selected sequences. Bonding techniques included electroforming and brazing. Materials of construction included electroformed nickel bonded to Nickel 200 and OFHC copper, electroformed copper bonded to OFHC copper, and 300 series stainless steel brazed to OFHC copper. Variations in outer wall strength, wall thickness, and defect size were evaluated for nondestructive test response.</p> <p style="text-align: center;">REPRODUCIBILITY OF THE ORIGINAL PAGE IS POOR</p>					
17. Key Words (Suggested by Author(s)) Nondestructive Tests Regenerative Chambers Metal Bond Integrity			18. Distribution Statement Unclassified - Unlimited This is the second volume of a two volume report. See Report No. NASA CR-134656 for the first volume.		
19. Security Classif. (of this report) Unclassified		20. Security Classif. (of this page) Unclassified		21. No. of Pages 193	22. Price*

* For sale by the National Technical Information Service, Springfield, Virginia 22151

FINAL REPORT
APPENDIX
NONDESTRUCTIVE TESTS OF REGENERATIVE CHAMBERS

by

G. A. Malone
L. Vecchies
R. Wood

Prepared for
National Aeronautics and Space Administration

June 1974

Technical Management
NASA, Lewis Research Center
Cleveland, Ohio
Chemical Propulsion Division

Rudolph A. Duscha

Bell Aerospace Company
P. O. Box 1
Buffalo, N. Y. 14240

CONTENTS

SECTION A - TASK II BOND STRENGTH VERIFICATION PANELS

Figure No.	Test Panel No.	Panel Description	Page
A-1	N-08	EF Nickel on Nickel 200, Full Bond	4
A-2	N-07	EF Nickel on Nickel 200, Weak Bond	6
A-3	N-20	EF Nickel on Nickel 200, Weak Bond	8
A-4	N-05	EF Nickel on Nickel 200, Nonbond	10
A-5	C-07N	EF Nickel on OFHC Copper, Full Bond	12
A-6	C-13N	EF Nickel on OFHC Copper, Weak Bond	14
A-7	C-14N	EF Nickel on OFHC Copper, Weak Bond	16
A-8	C-15N	EF Nickel on OFHC Copper, Nonbond	18
A-9	C-02C	EF Copper on OFHC Copper, Full Bond	20
A-10	C-05C	EF Copper on OFHC Copper, Weak Bond	22
A-11	C-10C	EF Copper on OFHC Copper, Weak Bond	24
A-12	C-11C	EF Copper on OFHC Copper, Nonbond	26
A-13	B-03	Brazed 304L S.S. on OFHC Copper, Full Bond	28
A-14	B-07	Brazed 304L S.S. on OFHC Copper, Weak Bond	30
A-15	B-10	Brazed 304L S.S. on OFHC Copper, Weak Bond	32
A-16	B-05	Brazed 304L S.S. on OFHC Copper, Nonbond	34

SECTION B - TASK III STANDARD PANELS FOR EQUIPMENT CALIBRATION

Figure No.	Test Panel No.	Panel Description	Page
B-1	N-14	Ultrasonic "C" Scan Thickness Sensitivity- Nonbond	36
B-2	N-15	Ultrasonic "C" Scan Thickness Sensitivity- Nonbond	38
B-3	N-16	Ultrasonic "C" Scan Thickness Sensitivity- Nonbond	40
B-4	N-17	Ultrasonic "C" Scan Pressure Response- Nonbond	42
B-5	N-25	Holography Stress Method- Nonbond	44
B-6	N-26	Holography Stress Method- Nonbond	46
B-7	N-12	Holography Bond Strength- Full Bond	48
B-8	N-18	Holography Bond Strength- Weak Bond	50
B-9	N-22	Holography Bond Strength- Weak Bond	52
B-10	N-23	Holography Flaw Size- Nonbond	54
B-11	N-24	Holography Flaw Size- Nonbond	56
B-12	N-10	Acoustic Emission Bond Strength- Full Bond	58
B-13	N-44	Acoustic Emission Bond Strength- Weak Bond	60
B-14	N-45	Acoustic Emission Bond Strength- Weak Bond	62
B-15	N-27	Acoustic Emission Nonbond Study	64
B-16	N-28	Acoustic Emission Nonbond Study	66
B-17	N-43	Acoustic Emission Flaw Location	68

CONTENTS

SECTION C - TASK IV NDE PANELS FOR EQUIPMENT LIMITATION STUDY

Figure No.	Test Panel No.	Panel Description	Page
Electroformed Nickel Coverplates on Nickel 200 Baseplates:			
C-1	N-11	Standard Flaw Area, Full Bond	70
C-2	N-29	Standard Flaw Area, Weak Bond	72
C-3	N-30	Standard Flaw Area, Weak Bond	74
C-4	N-38	Standard Flaw Area, Nonbond	76
C-5	N-31	Second Flaw Area, Weak Bond	78
C-6	N-32	Second Flaw Area, Weak Bond	80
C-7	N-39	Second Flaw Area, Nonbond	82
C-8	N-09	Coverplate Thickness, Full Bond	84
C-9	N-33	Coverplate Thickness, Weak Bond	86
C-10	N-34	Coverplate Thickness, Weak Bond	88
C-11	N-40	Coverplate Thickness, Nonbond	90
C-12	N-21	Coverplate Strength, Full Bond	92
C-13	N-36	Coverplate Strength, Weak Bond	94
C-14	N-37	Coverplate Strength, Weak Bond	96
C-15	N-41	Coverplate Strength, Nonbond	98
C-16	N-13	Surface Flatness, Full Bond	100
C-17	N-46	Surface Flatness, Weak Bond	102
C-18	N-42	Surface Flatness, Nonbond	104
C-19	N-56	Land Width, Full Bond	106
C-20	N-57	Land Width, Weak Bond	108
C-21	N-58	Land Width, Nonbond	110
Electroformed Nickel Coverplates on OFHC Copper Baseplates:			
C-22	C-08N	Standard Flaw Area, Full Bond	112
C-23	C-28N	Standard Flaw Area, Weak Bond	114
C-24	C-29N	Standard Flaw Area, Weak Bond	116
C-25	C-30N	Standard Flaw Area, Nonbond	118
C-26	C-32N	Second Flaw Area, Weak Bond	120
C-27	C-33N	Second Flaw Area, Weak Bond	122
C-28	C-34N	Second Flaw Area, Nonbond	124
C-29	C-09N	Coverplate Thickness, Full Bond	126
C-30	C-35N	Coverplate Thickness, Weak Bond	128
C-31	C-36N	Coverplate Thickness, Weak Bond	130
C-32	C-37N	Coverplate Thickness, Nonbond	132
C-33	C-06N	Coverplate Strength, Full Bond	134
C-34	C-38N	Coverplate Strength, Weak Bond	136
C-35	C-39N	Coverplate Strength, Weak Bond	138
C-36	C-03N	Coverplate Strength, Nonbond	140
Electroformed Copper Coverplates on OFHC Copper Baseplates:			
C-37	C-01C	Standard Flaw Area, Full Bond	142
C-38	C-16C	Standard Flaw Area, Weak Bond	144
C-39	C-17C	Standard Flaw Area, Weak Bond	146
C-40	C-18C	Standard Flaw Area, Nonbond	148
C-41	C-19C	Second Flaw Area, Weak Bond	150
C-42	C-20C	Second Flaw Area, Weak Bond	152
C-43	C-21C	Second Flaw Area, Nonbond	154

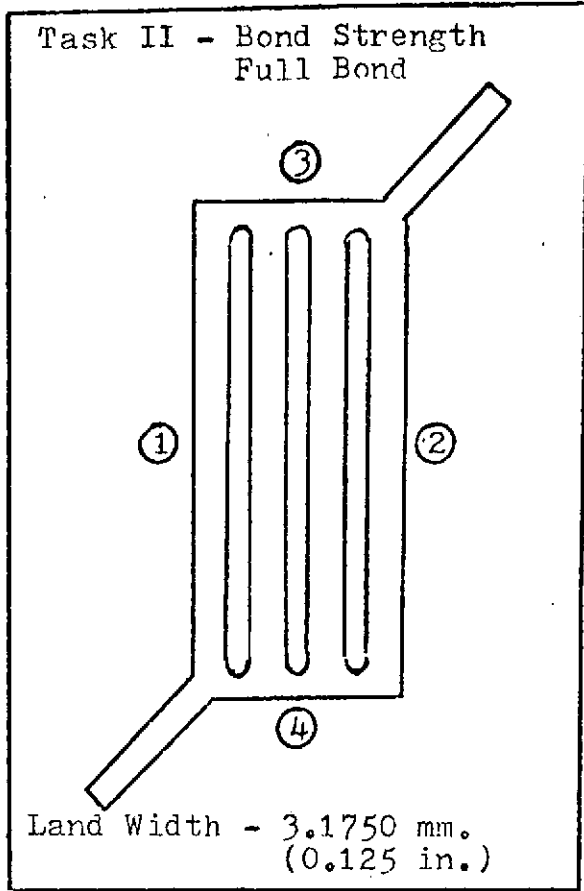
CONTENTS

SECTION C - TASK IV NDE PANELS FOR EQUIPMENT LIMITATION STUDY

Figure No.	Test Panel No.	Panel Description	Page
Electroformed Copper Coverplates on OFHC Copper Baseplates:			
C-44	C-04C	Coverplate Thickness, Full Bond	156
C-45	C-22C	Coverplate Thickness, Weak Bond	158
C-46	C-23C	Coverplate Thickness, Weak Bond	160
C-47	C-24C	Coverplate Thickness, Nonbond	162
C-48	C-12C	Coverplate Strength, Full Bond	164
C-49	C-25C	Coverplate Strength, Weak Bond	166
C-50	C-26C	Coverplate Strength, Weak Bond	168
C-51	C-27C	Coverplate Strength, Nonbond	170
Stainless Steel Coverplates Brazed on OFHC Copper Baseplates:			
C-52	B-04	Standard Flaw Area, Full Bond	172
C-53	B-18	Standard Flaw Area, Weak Bond	174
C-54	B-16	Standard Flaw Area, Weak Bond	176
C-55	B-08	Standard Flaw Area, Nonbond	178
C-56	B-20	Second Flaw Area, Weak Bond	180
C-57	B-17	Second Flaw Area, Weak Bond	182
C-58	B-09	Second Flaw Area, Nonbond	184
C-59	B-06	Coverplate Thickness, Full Bond	186
C-60	B-19	Coverplate Thickness, Weak Bond	188
C-61	B-15	Coverplate Thickness, Weak Bond	190
C-62	B-11	Coverplate Thickness, Nonbond	192

**REPRODUCIBILITY OF THE
ORIGINAL PAGE IS POOR**

ELECTROFORMED PANEL NO. N-08



BASEPLATE

MATERIAL: Nickel 200

CENTER LAND FLATNESS VARIATION:
'0.003 in. (0.0762 mm.)

THICKNESS:	MM.	INCHES
①	6.3500	0.2500
②	6.3525	0.2501
③	6.2433	0.2458
④	6.3500	0.2500

COVERPLATE

MATERIAL: Electroformed Nickel

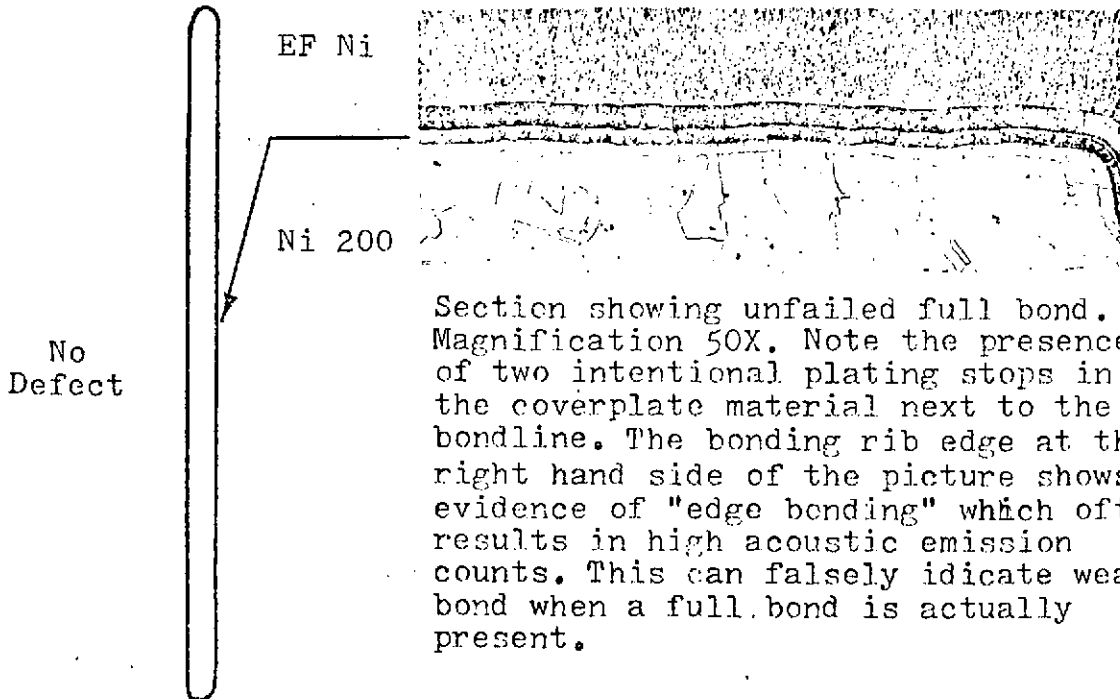
THICKNESS:	MM.	INCHES
①	1.4834	0.0584
②	1.4453	0.0569
③	1.5748	0.0620
④	1.4122	0.0556

PRESSURE REQUIRED TO FAIL BOND:

Bond did not fail at a pressure
of 6.90×10^7 N/m² (10,000 psi)

CENTER LAND DEFECT

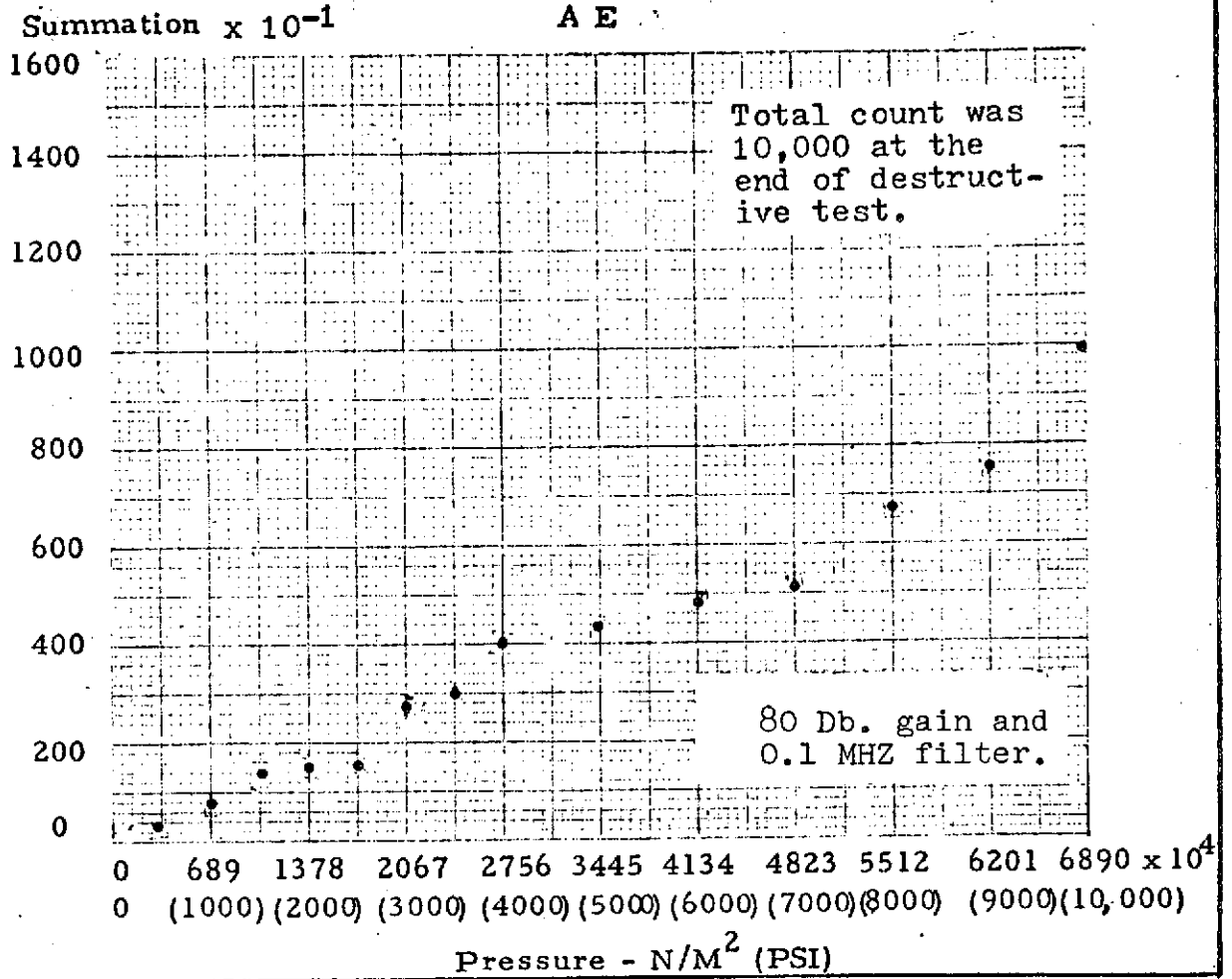
METALLOGRAPHIC ANALYSIS:



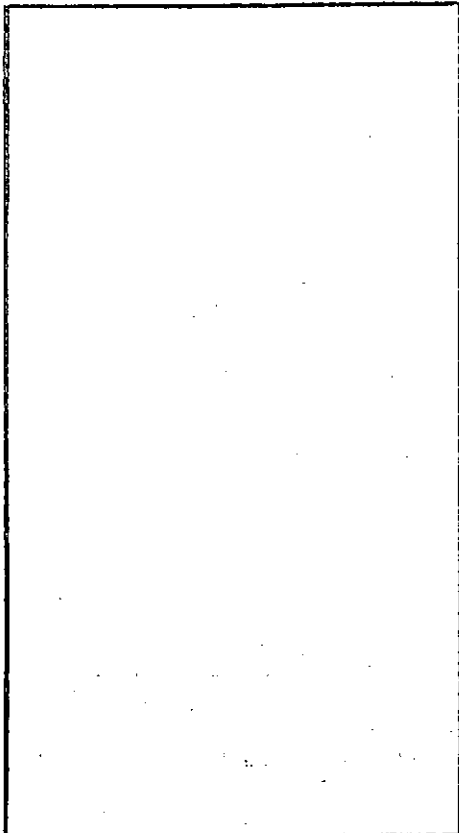
Section showing unfailed full bond. Magnification 50X. Note the presence of two intentional plating stops in the coverplate material next to the bondline. The bonding rib edge at the right hand side of the picture shows evidence of "edge bonding" which often results in high acoustic emission counts. This can falsely indicate weak bond when a full bond is actually present.

FIGURE A-1

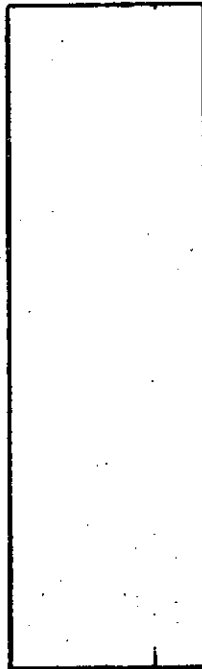
Panel No. N-08



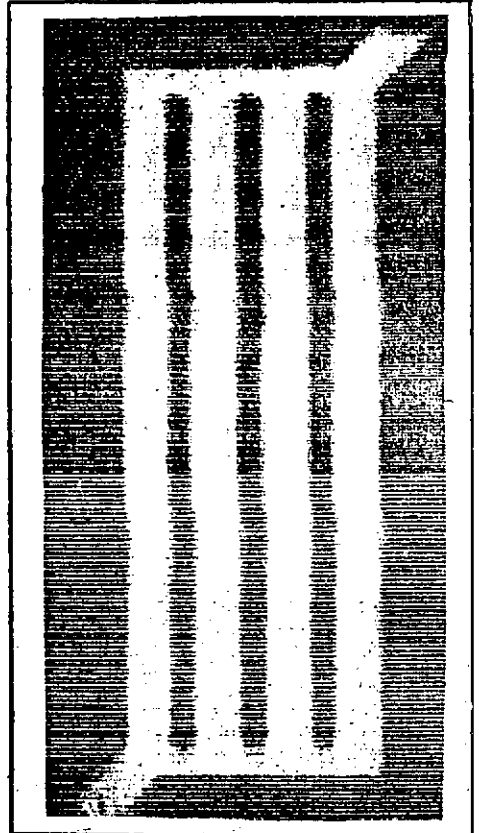
HNDT



AE
FLAW LOCATOR
CENTER LAND

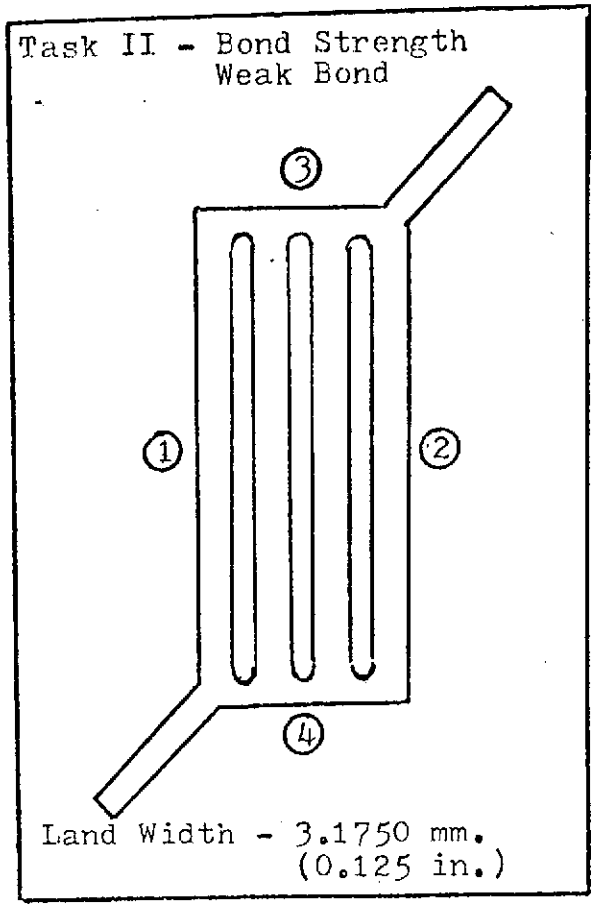


UT



REPRODUCIBILITY OF THE ORIGINAL PAGE IS POOR

ELECTROFORMED PANEL NO. N-07



BASEPLATE

MATERIAL: Nickel 200

CENTER LAND FLATNESS VARIATION:
0.007 in. (0.1778 mm.)

THICKNESS:	MM.	INCHES
①	6.2433	0.2458
②	6.2433	0.2458
③	6.2306	0.2453
④	6.2281	0.2452

COVERPLATE

MATERIAL: Electroformed Nickel

THICKNESS:	MM.	INCHES
①	1.3614	0.0536
②	1.3335	0.0525
③	1.3462	0.0530
④	1.3614	0.0536

PRESSURE REQUIRED TO FAIL BOND:

Bond failed at a pressure of
 $4.69 \times 10^7 \text{ N/m}^2$ (6,800 psi)

CENTER LAND DEFECT

METALLOGRAPHIC ANALYSIS:

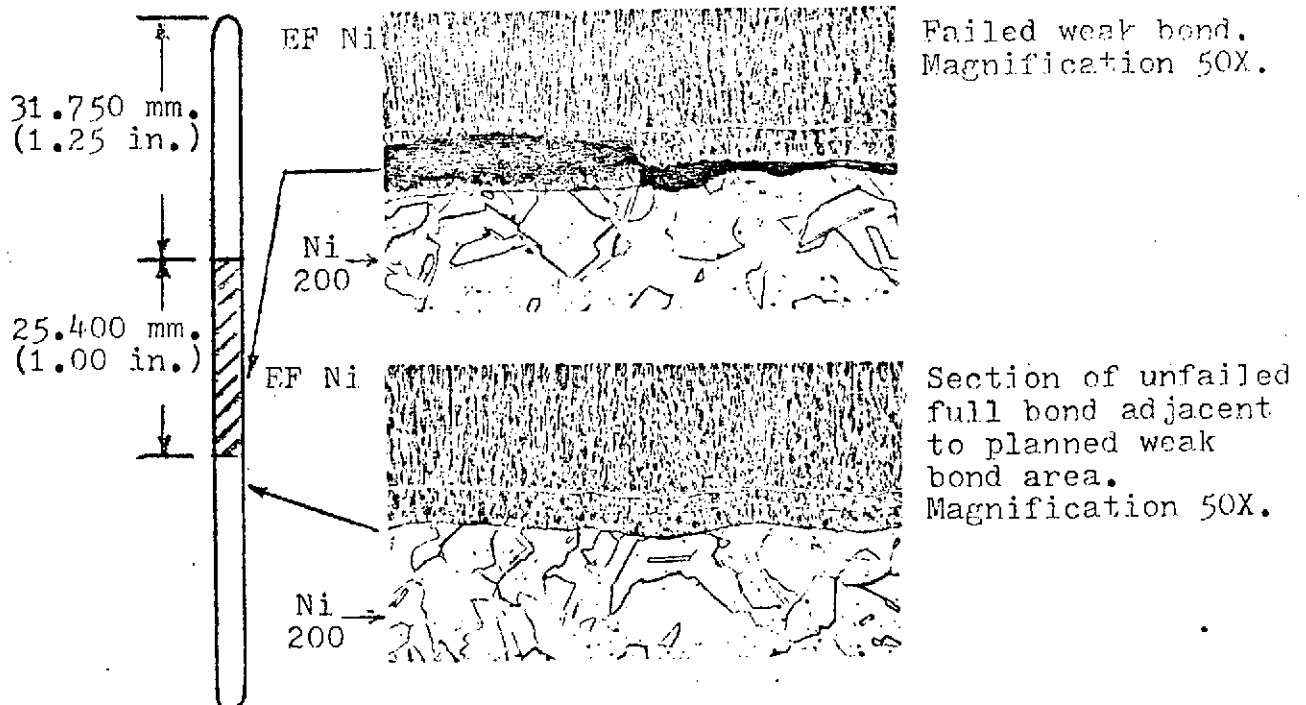
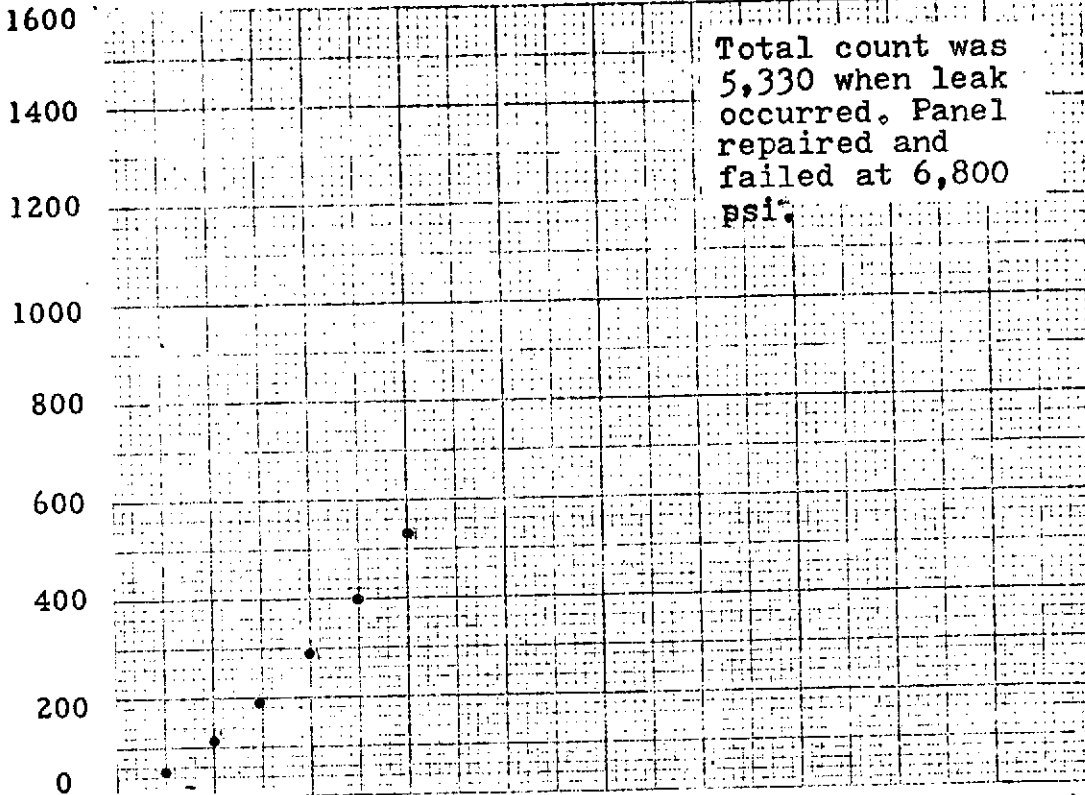


FIGURE A-2

Panel No. N-07

Summation $\times 10^{-1}$

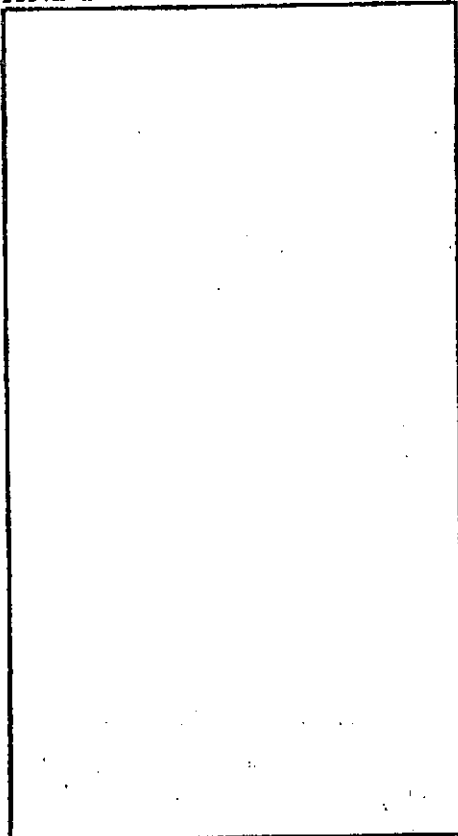
A E



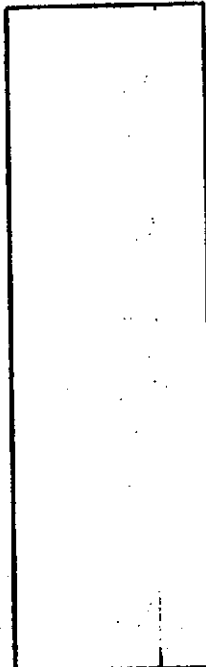
0 689 1378 2067 2756 3445 4134 4823 5512 6201 6890 $\times 10^4$
0 (1000) (2000) (3000) (4000) (5000) (6000) (7000) (8000) (9000) (10,000)

Pressure - N/M² (PSI)

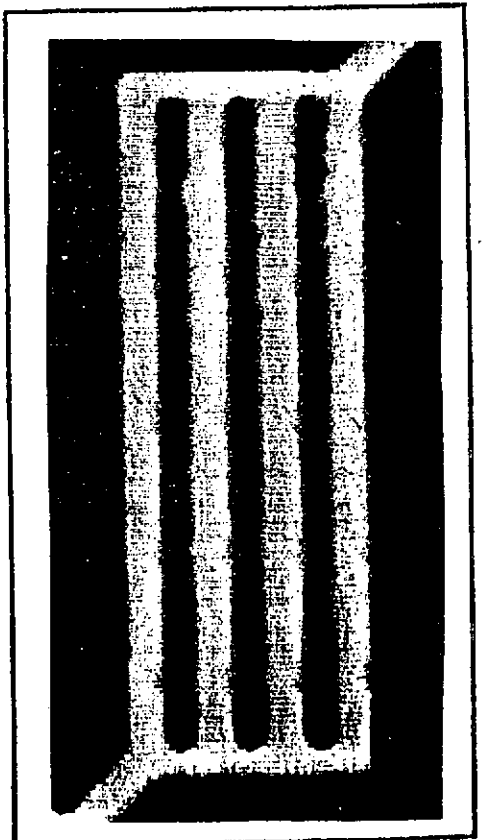
HNDT



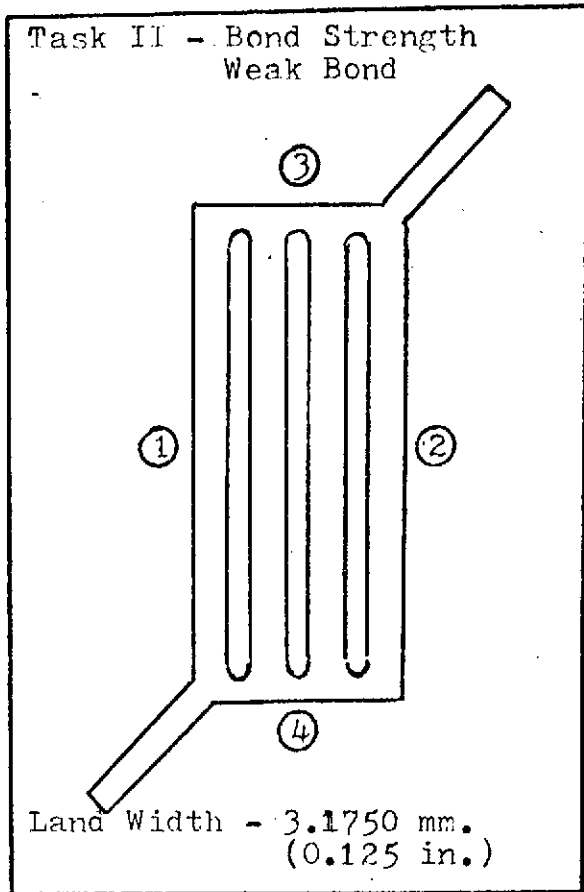
A E
FLAW LOCATOR
CENTER LAND



UT



ELECTROFORMED PANEL NO. N-20



BASEPLATE

MATERIAL: Nickel 200

CENTER LAND FLATNESS VARIATION:
0.007 in. (0.1778 mm.)

THICKNESS:	MM.	INCHES
①	6.1976	0.2440
②	6.1773	0.2432
③	6.1773	0.2432
④	6.1570	0.2424

COVERPLATE

MATERIAL: Electroformed Nickel

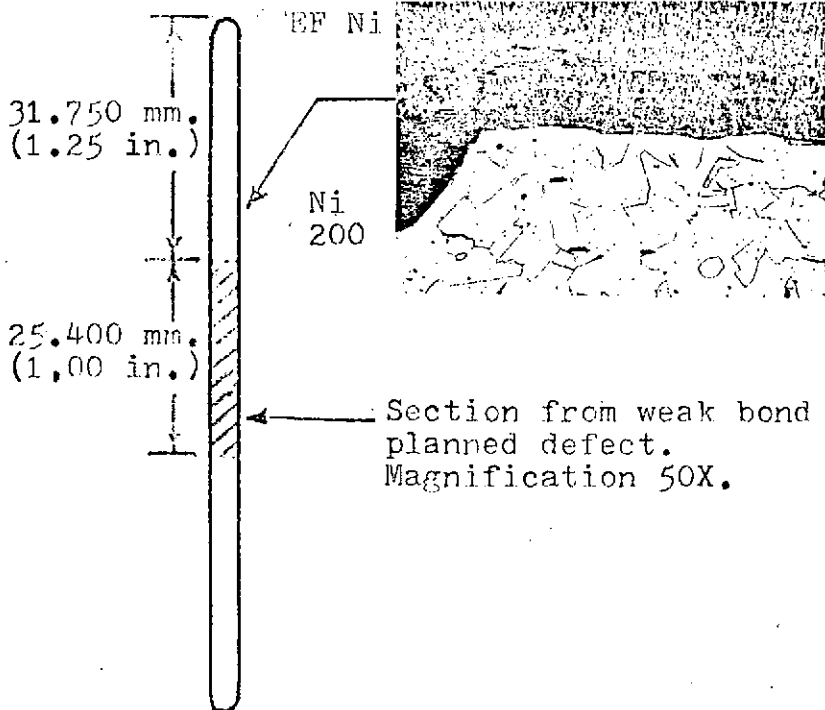
THICKNESS:	MM.	INCHES
①	1.3132	0.0517
②	1.3614	0.0536
③	1.3792	0.0543
④	1.4376	0.0566

PRESSURE REQUIRED TO FAIL BOND:

Bond failed at a pressure of
 $4.83 \times 10^7 \text{ N/m}^2$ (7,000 psi)

CENTER LAND DEFECT

METALLOGRAPHIC ANALYSIS:



Full bond area. Note
initiation of bond
tearing. Magnification
50X.

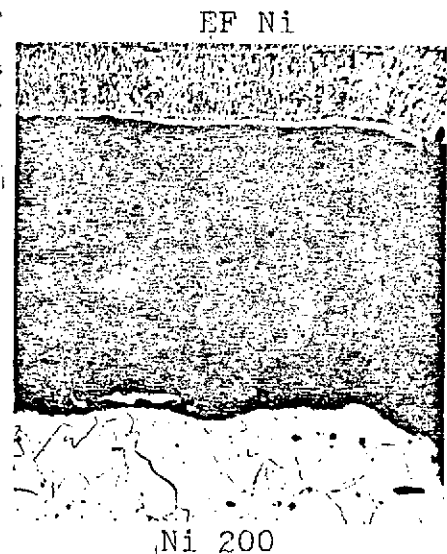
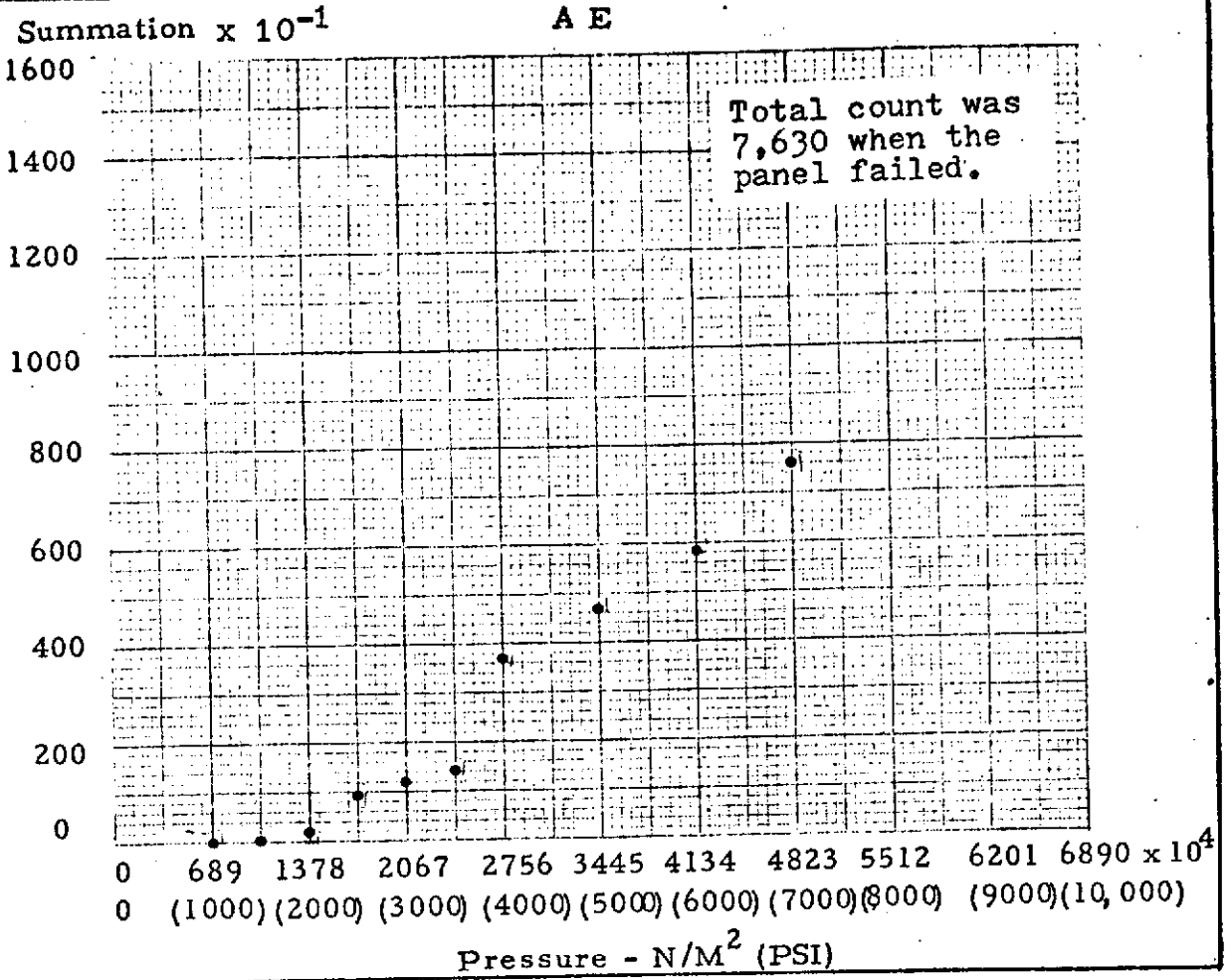
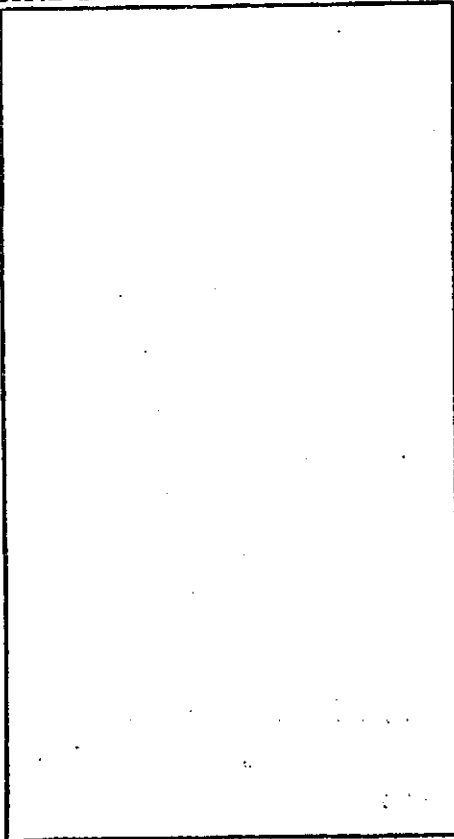


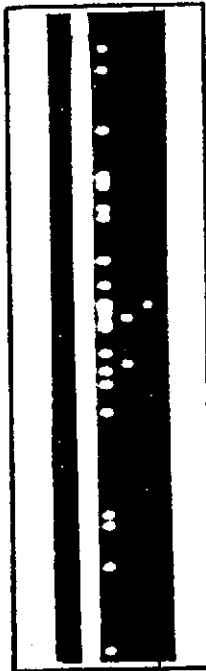
FIGURE A-3



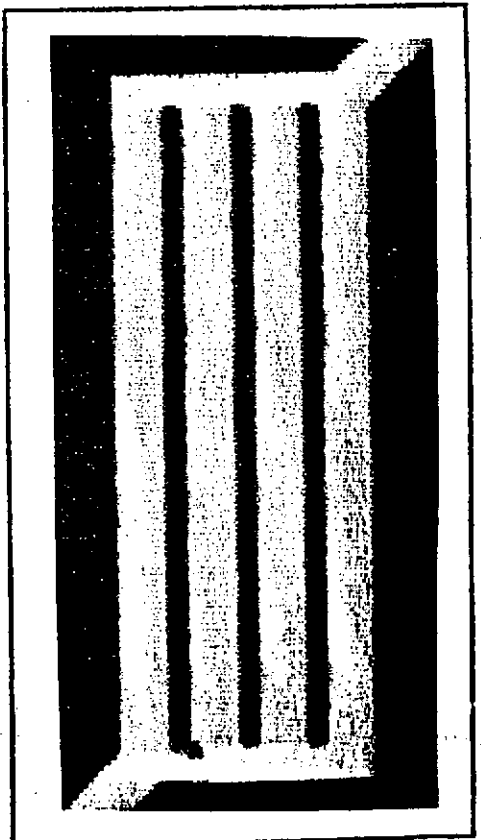
HNDT



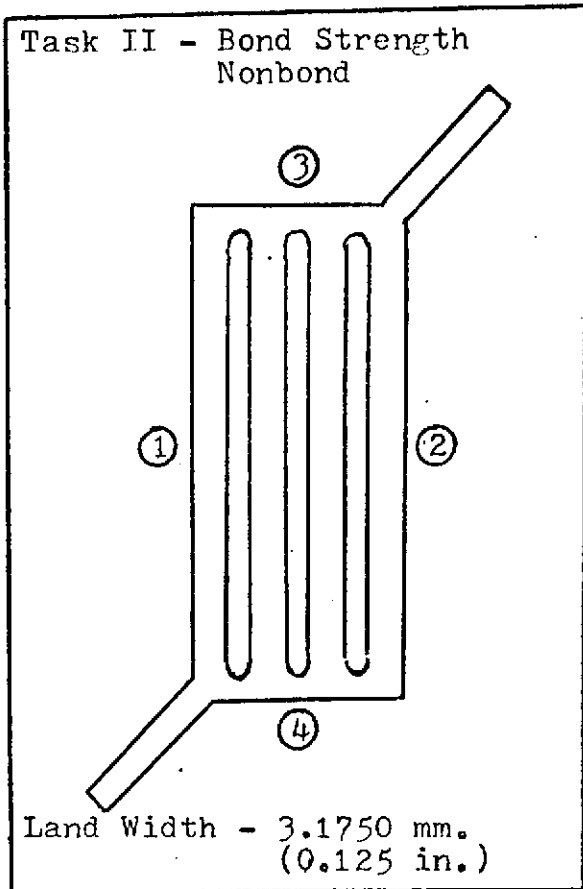
AE
FLAW LOCATOR
CENTER LAND



UT



ELECTROFORMED PANEL NO. N-05 "A"



BASEPLATE

MATERIAL: Nickel 200

CENTER LAND FLATNESS VARIATION:
0.006 in. (0.1524 mm.)

THICKNESS:	MM.	INCHES
①	6.1722	0.2430
②	6.1239	0.2411
③	6.1544	0.2423
④	6.1468	0.2420

COVERPLATE

MATERIAL: Electroformed Nickel

THICKNESS:	MM.	INCHES
①	1.0973	0.0432
②	1.1735	0.0462
③	1.1557	0.0455
④	1.1252	0.0443

PRESSURE REQUIRED TO FAIL BOND:

Defect area bulged at a pressure of 1.38×10^7 N/m² (2,000 psi).

CENTER LAND DEFECT.

METALLOGRAPHIC ANALYSIS:

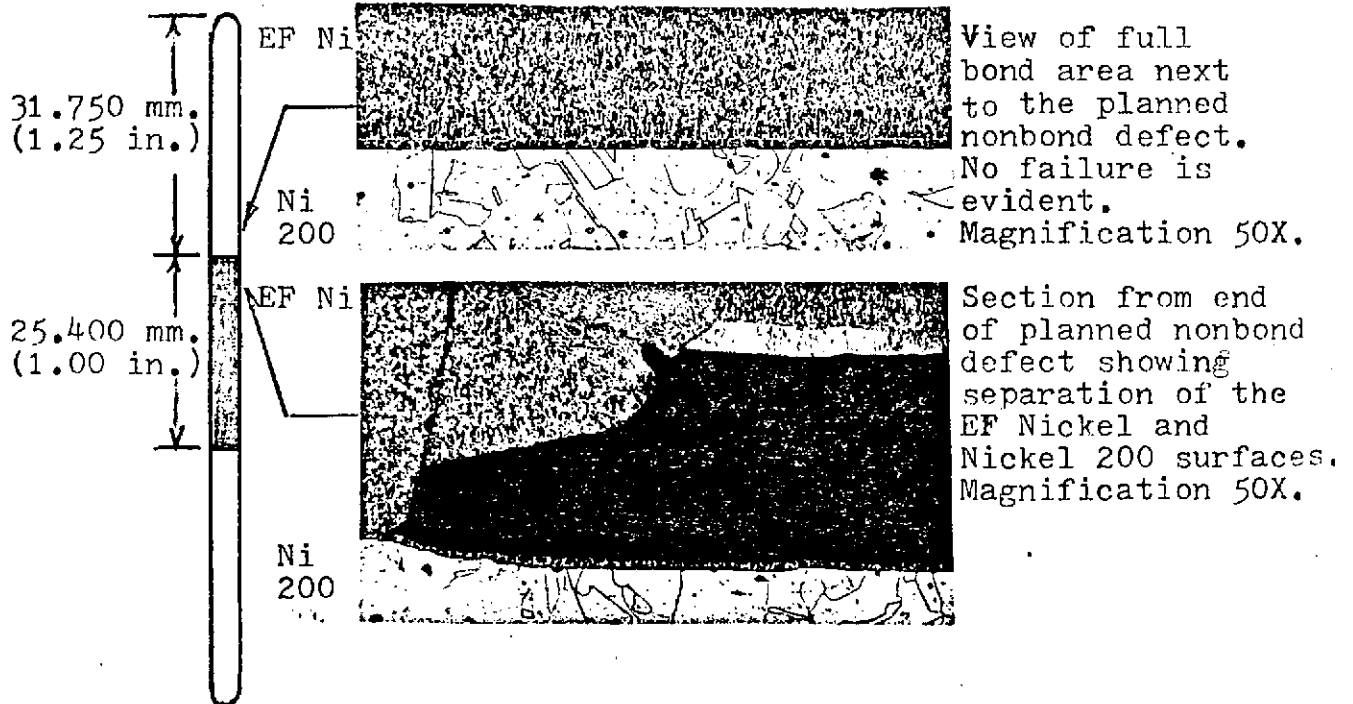
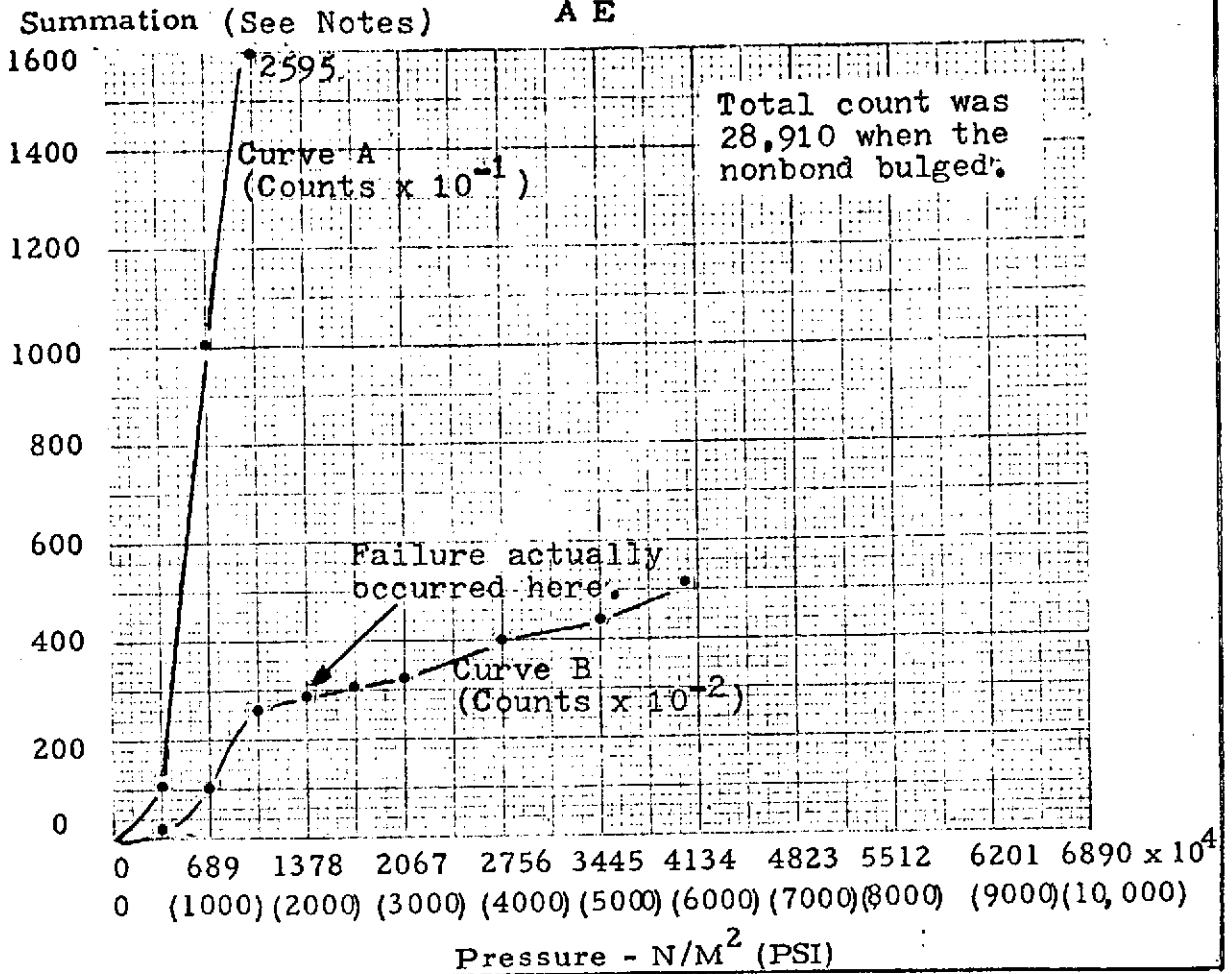


FIGURE A-4

REPRODUCIBILITY OF THE ORIGINAL PAGE IS POOR.

Panel No. N-05"A"



REPRODUCIBILITY OF THE ORIGINAL PAGE IS POOR.

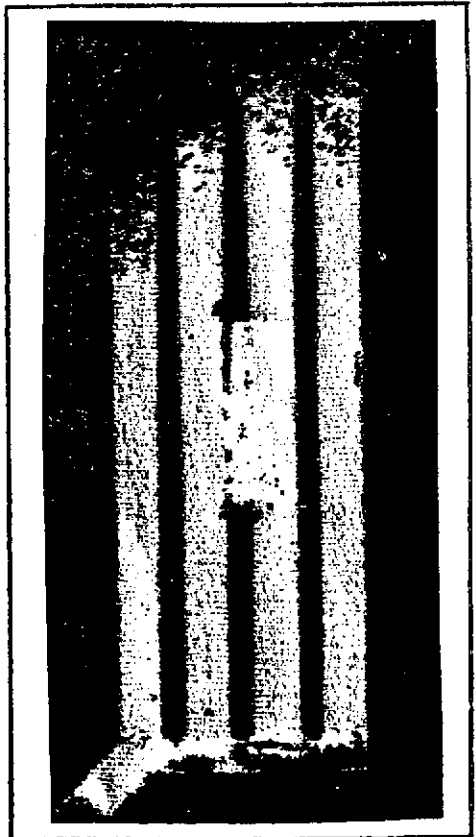
HNDT

Acoustic emission count was plotted with two multipliers to show the effect of the narrow unplanned tack bond along the left side of the planned nonbond, Curve A. Curve B shows entire count x 10⁻² through defect bulge and into full bond failure along the land extremities.

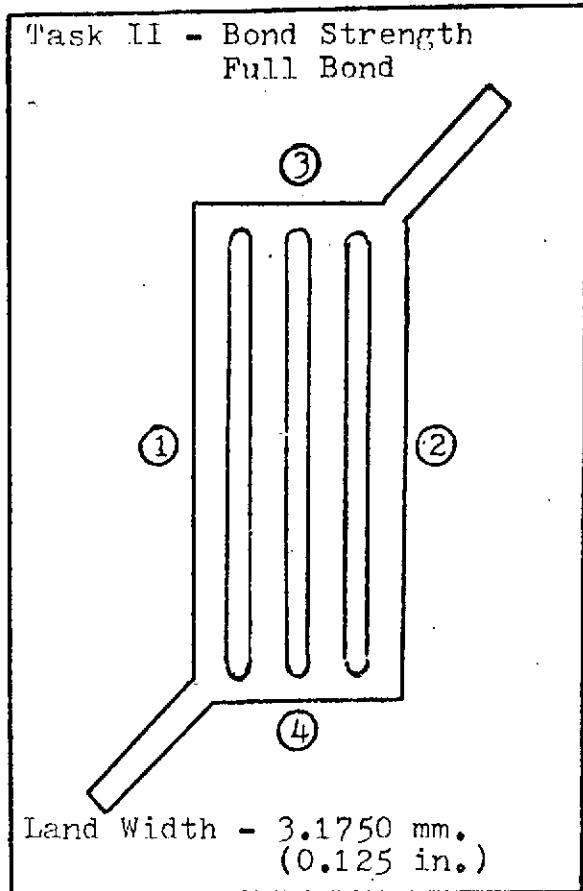
AE
FLAW LOCATOR
CENTER LAND



UT



ELECTROFORMED PANEL NO. C-07N



BASEPLATE

MATERIAL: OFHC Copper

CENTER LAND FLATNESS VARIATION:
0.004 in. (0.1016 mm.)

THICKNESS:	MM.	INCHES
①	6.5735	0.2588
②	6.5862	0.2593
③	6.6294	0.2610
④	6.5278	0.2570

COVERPLATE

MATERIAL: Electroformed Nickel

THICKNESS:	MM.	INCHES
①	1.4986	0.0590
②	1.5113	0.0595
③	1.4122	0.0556
④	1.5494	0.0610

PRESSURE REQUIRED TO FAIL BOND:

Bond did not fail at a pressure of
 6.90×10^7 N/m² (10,000 psi)

CENTER LAND DEFECT

METALLOGRAPHIC ANALYSIS:

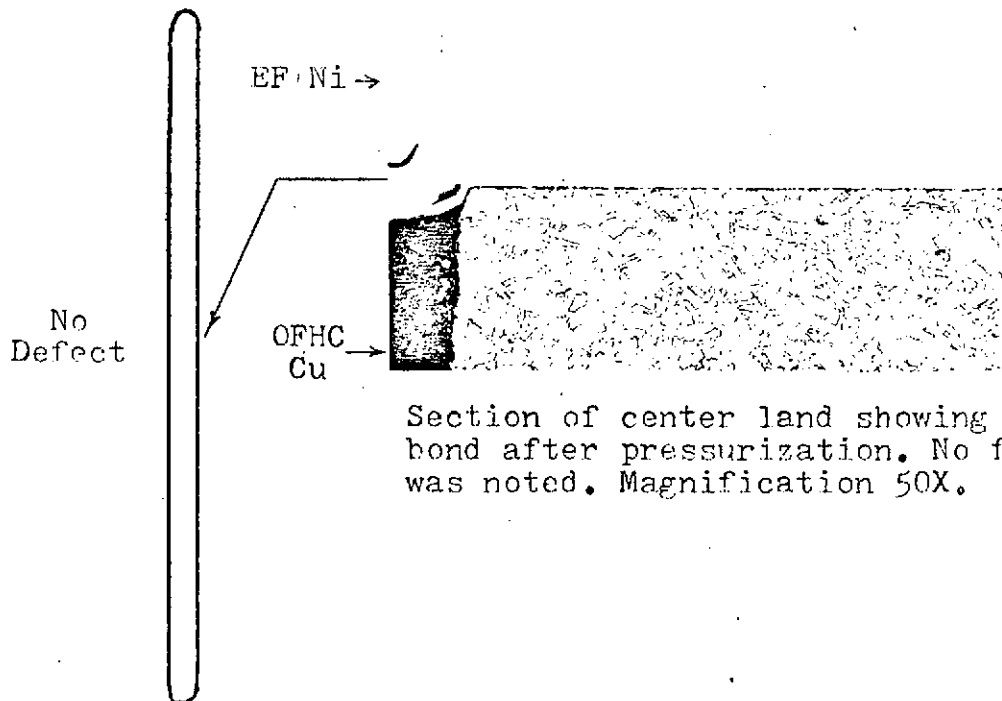
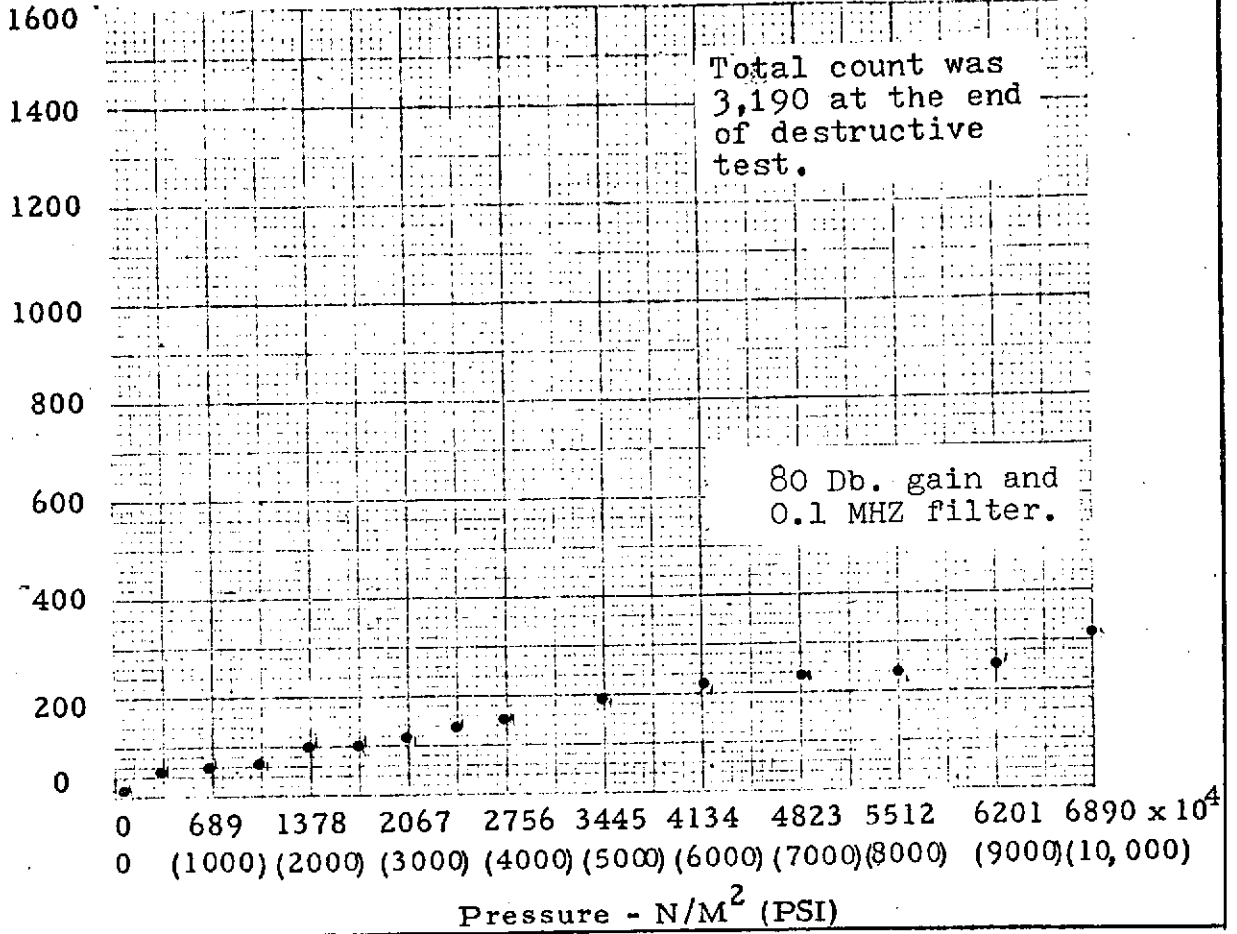


FIGURE A-5

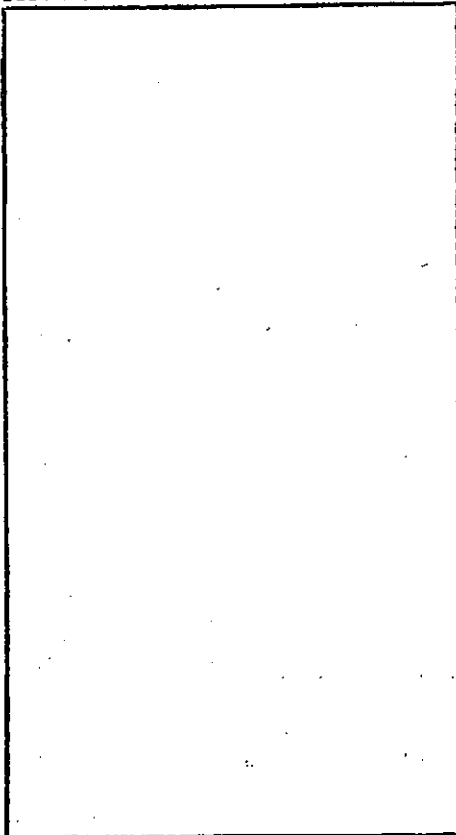
Panel No. C-07N

Summation x 10⁻¹

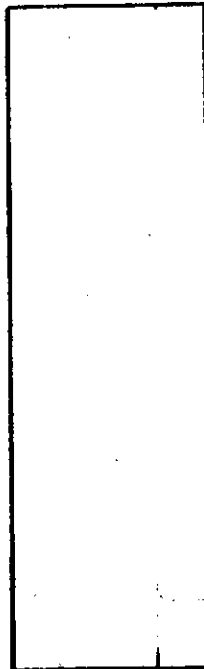
A E



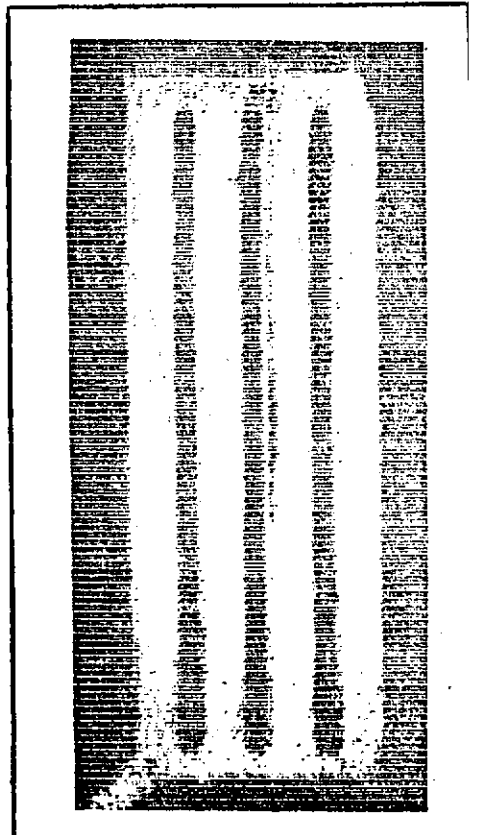
HNDT



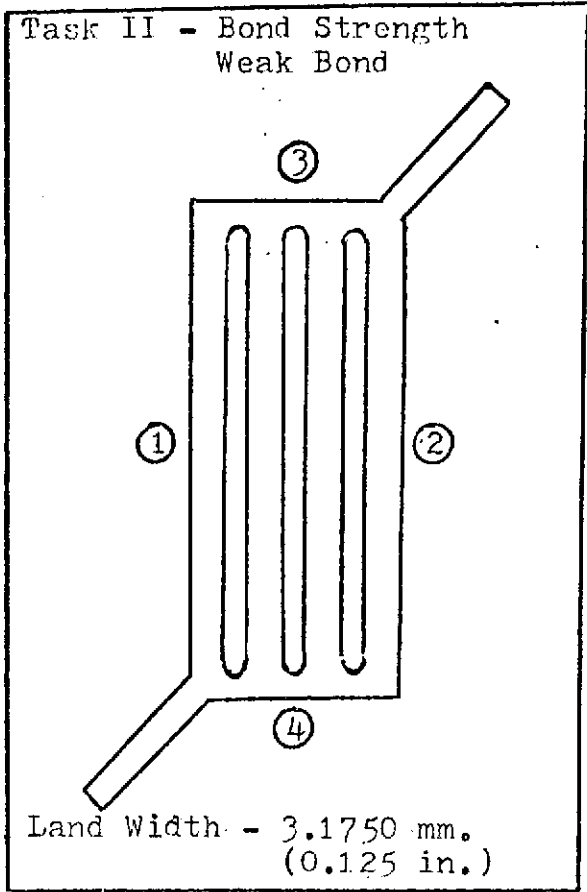
AE
FLAW LOCATOR
CENTER LAND



UT



ELECTROFORMED PANEL NO. C-156



BASEPLATE

MATERIAL: OFHC Copper

CENTER LAND FLATNESS VARIATION:
0.001 in. (0.0254 mm.)

THICKNESS:	MM.	INCHES
①	6.6294	0.2610
②	6.6218	0.2607
③	6.6091	0.2602
④	6.6802	0.2630

COVERPLATE

MATERIAL: Electroformed Nickel

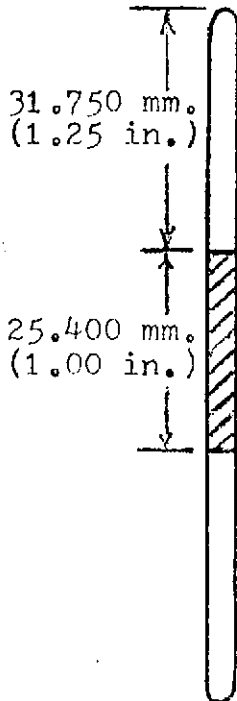
THICKNESS:	MM.	INCHES
①	1.3970	0.0550
②	1.4021	0.0552
③	1.3919	0.0548
④	1.3564	0.0534

PRESSURE REQUIRED TO FAIL BOND:

Bond failed at a pressure of
 2.76×10^7 N/m² (4,000 psi)

CENTER LAND DEFECT

METALLOGRAPHIC ANALYSIS:



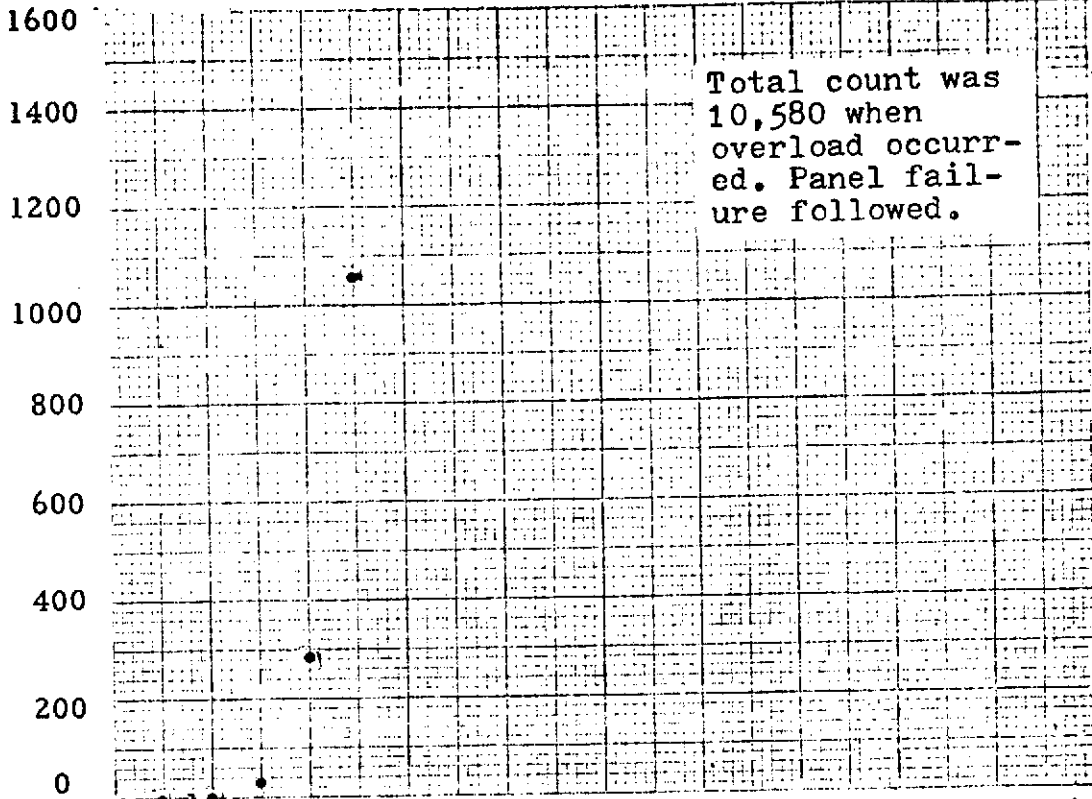
This panel was not metallurgically sectioned. The process used to produce the weak bond on this panel was not used in subsequent panels. See results for panel C-14N, Figure A-7, for the selected weak bond process.

FIGURE A-6

Panel No. C-13N

Summation $\times 10^{-1}$

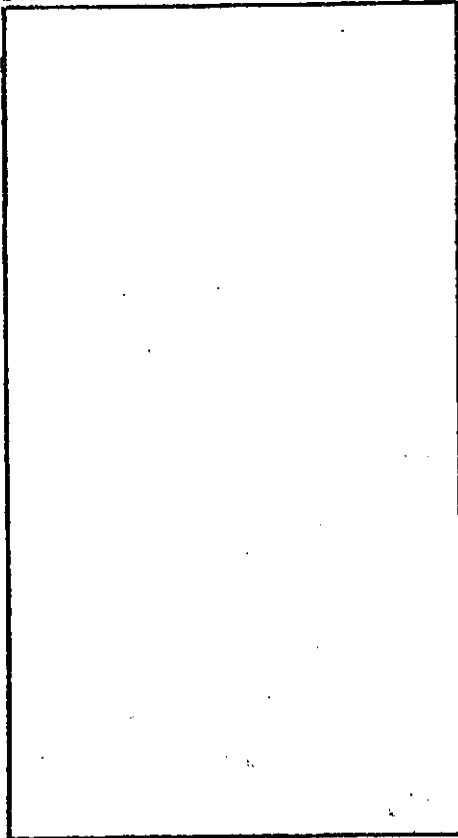
A E



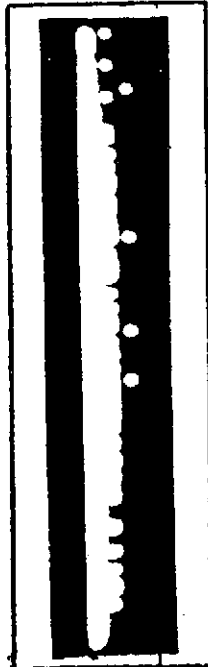
0 689 1378 2067 2756 3445 4134 4823 5512 6201 6890 $\times 10^4$
0 (1000) (2000) (3000) (4000) (5000) (6000) (7000) (8000) (9000) (10,000)

Pressure - N/M^2 (PSI)

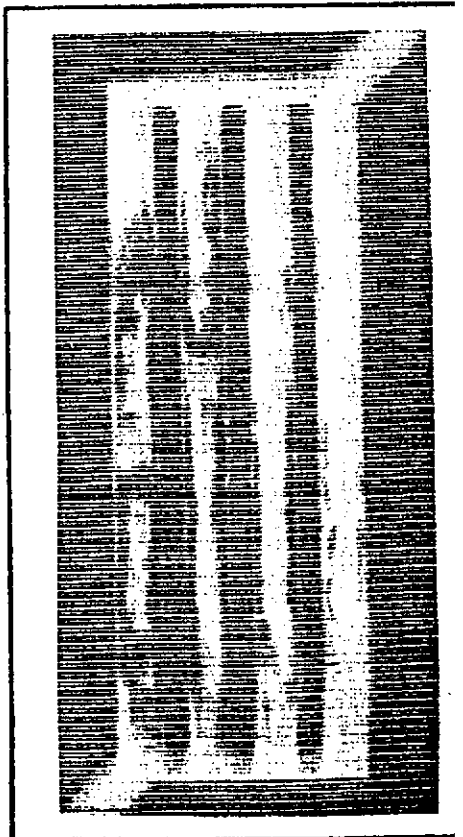
HNDT



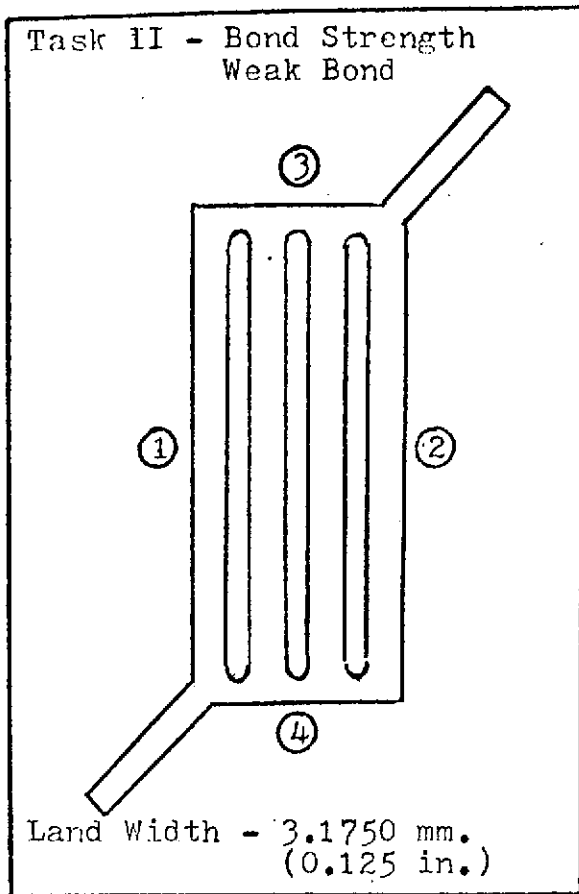
AE
FLAW LOCATOR
CENTER LAND



UT



ELECTROFORMED PANEL NO. C-14N



BASEPLATE

MATERIAL: OFHC Copper

CENTER LAND FLATNESS VARIATION:
0.005 in. (0.1270 mm.)

THICKNESS:	MM.	INCHES
①	6.5786	0.2590
②	6.6294	0.2610
③	6.5329	0.2572
④	6.6802	0.2630

COVERPLATE

MATERIAL: Electroformed Nickel

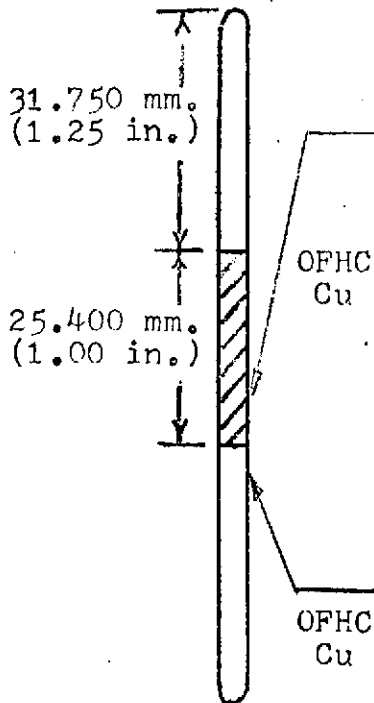
THICKNESS:	MM.	INCHES
①	1.4173	0.0558
②	1.3919	0.0548
③	1.4148	0.0557
④	1.3614	0.0536

PRESSURE REQUIRED TO FAIL BOND:

Bond failed at a pressure of
 $2.55 \times 10^7 \text{ N/m}^2$ (3,700 psi)

CENTER LAND DEFECT

METALLOGRAPHIC ANALYSIS:



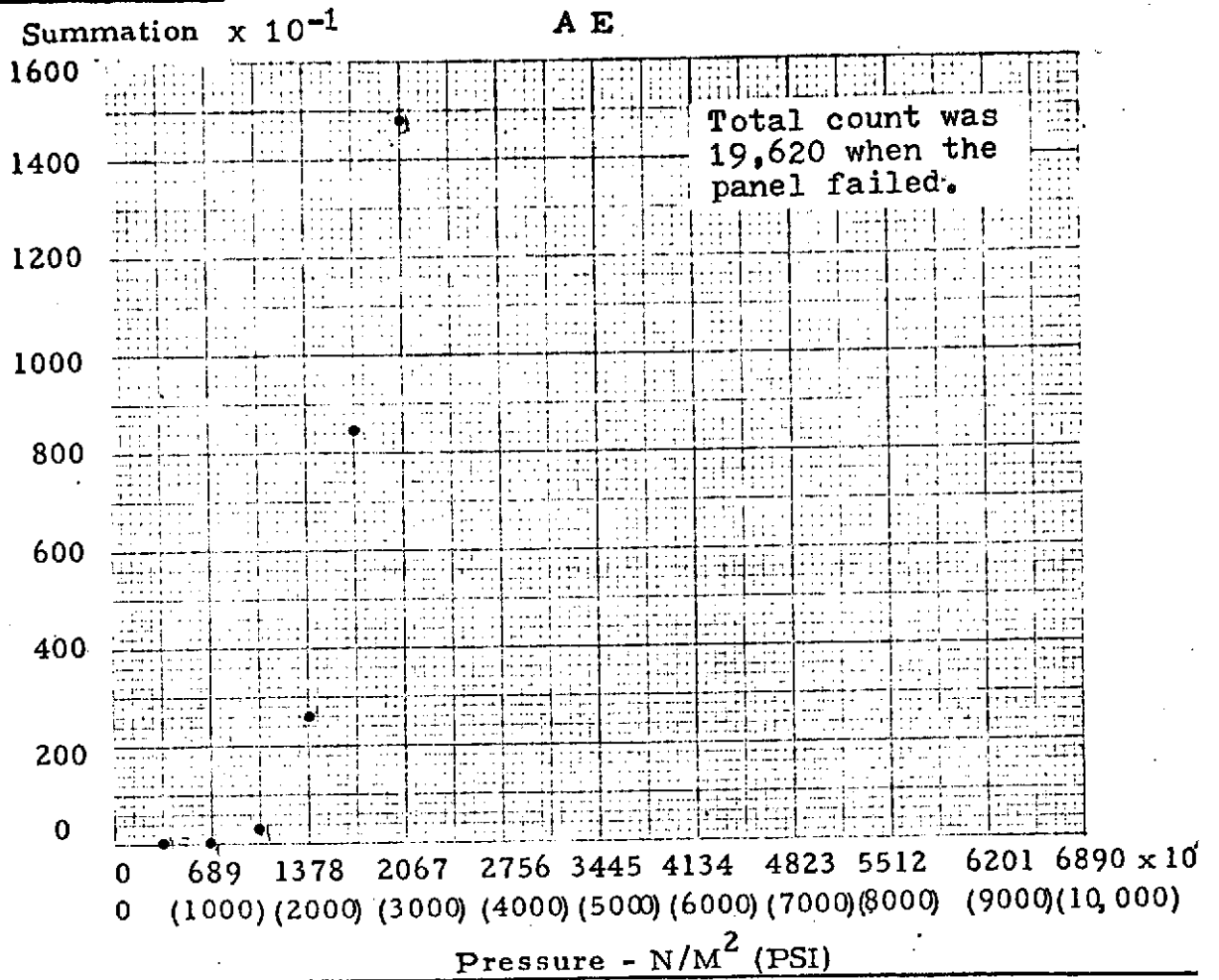
Section of baseplate portion of planned weak bond. Minor metal disturbance indicates a very weak bond. Magnification 50X. Nickel coverplate bulged out of view.



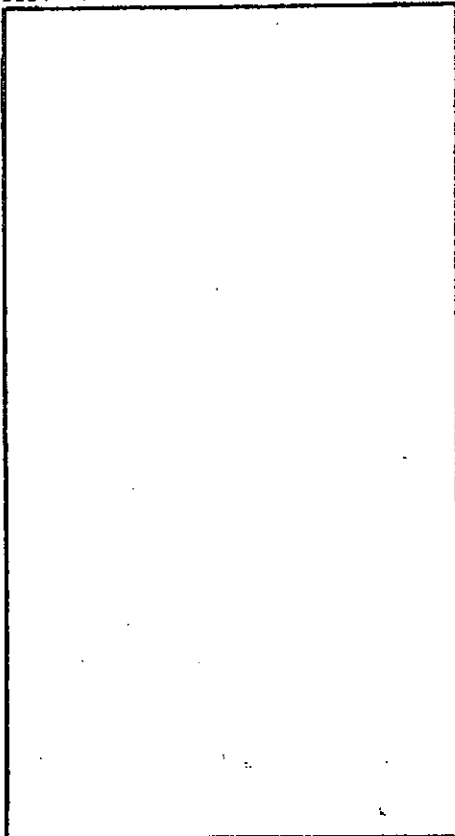
Section of baseplate portion of planned full bond next to the weak bond. Metal tearing was noted in this region. Magnification 200X.

FIGURE A-7

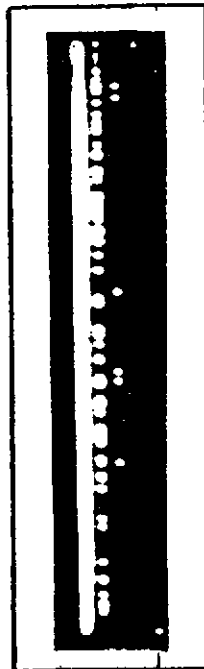
Panel No. C-14N



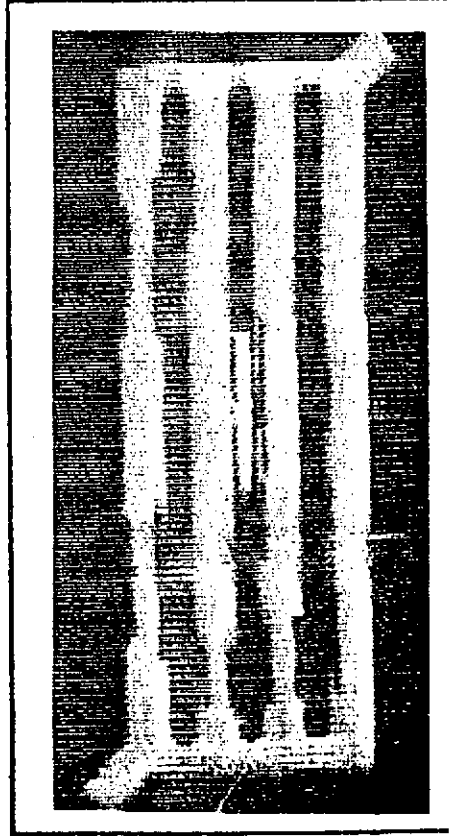
HNDT



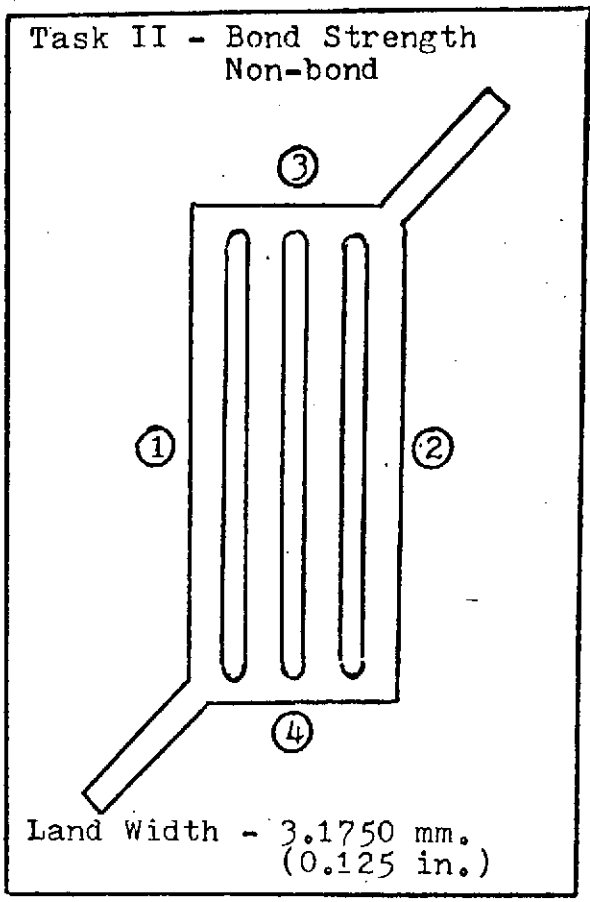
AE
FLAW LOCATOR
CENTER LAND



UT



ELECTROFORMED PANEL NO. C-15N



BASEPLATE

MATERIAL: OFHC Copper

CENTER LAND FLATNESS VARIATION:
0.003 in. (0.0762 mm.)

THICKNESS:	MM.	INCHES
①	6.6853	0.2632
②	6.6497	0.2618
③	6.6802	0.2630
④	6.6294	0.2610

COVERPLATE

MATERIAL: Electroformed Nickel

THICKNESS:	MM.	INCHES
①	1.4021	0.0552
②	1.5037	0.0592
③	1.3995	0.0551
④	1.4427	0.0568

PRESSURE REQUIRED TO FAIL BOND:

Bond failed at a pressure of
 $2.76 \times 10^7 \text{ N/m}^2$ (4,000 psi).
Bulging started at approximately
 $2.07 \times 10^7 \text{ N/m}^2$ (3,000 psi).

CENTER LAND DEFECT

METALLOGRAPHIC ANALYSIS:

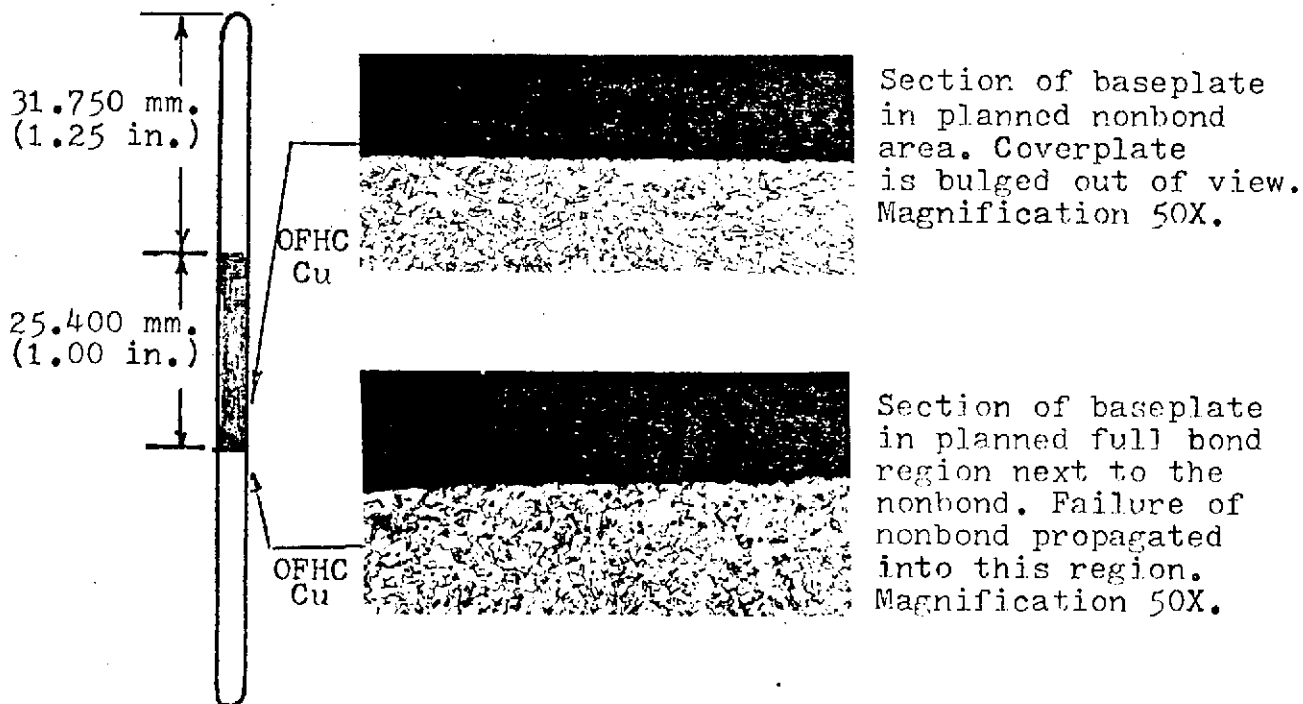
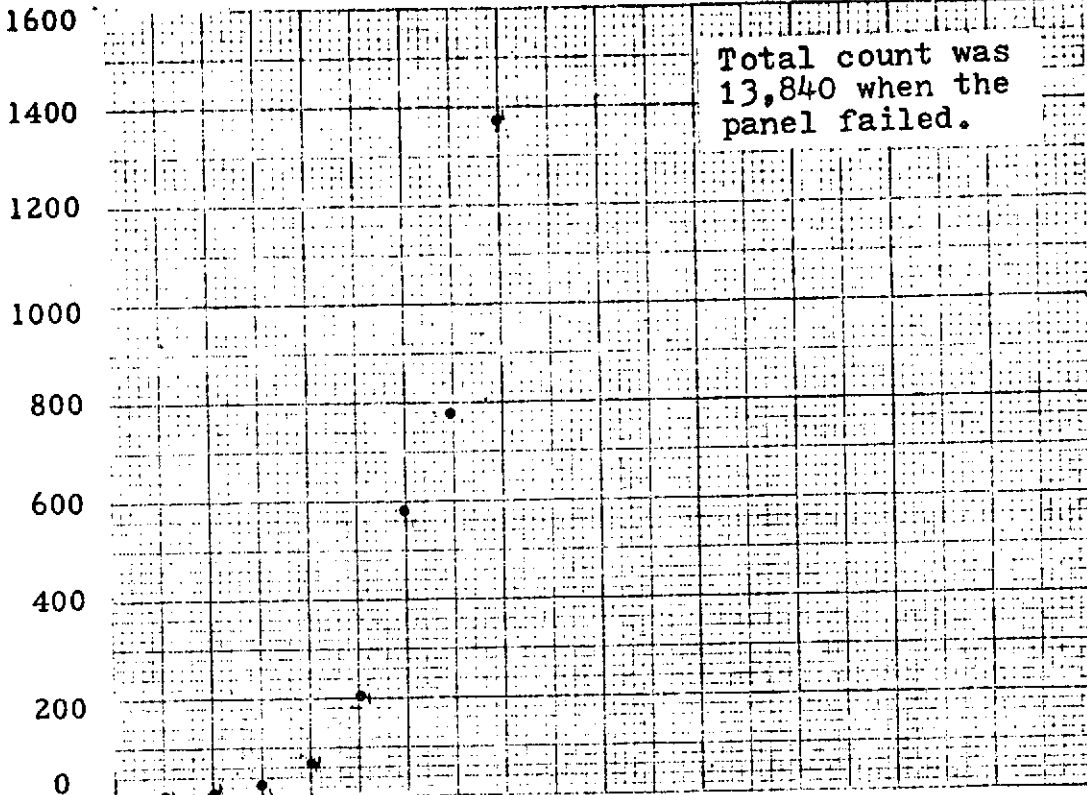


FIGURE A-8

Panel No. C-15N

Summation $\times 10^{-1}$

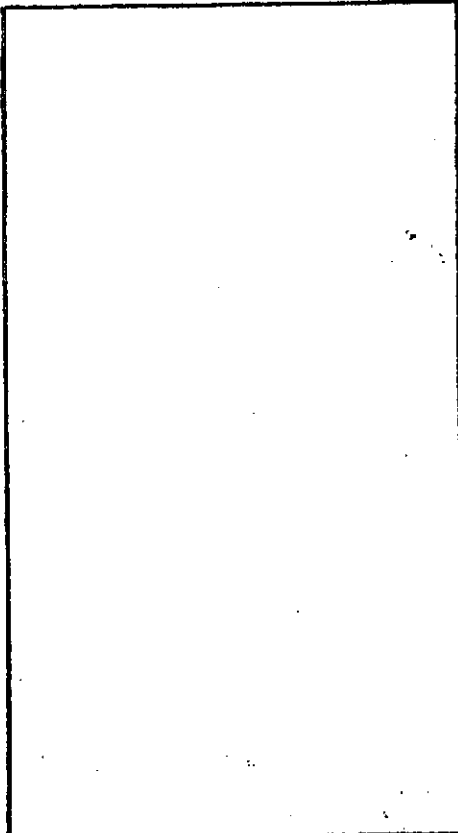
A E



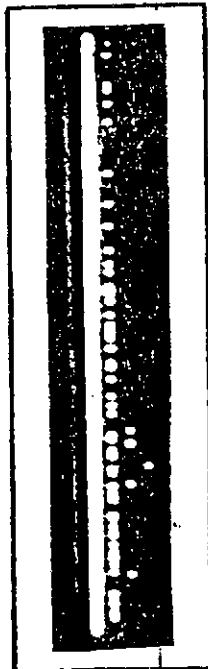
0 689 1378 2067 2756 3445 4134 4823 5512 6201 6890 $\times 10^4$
0 (1000) (2000) (3000) (4000) (5000) (6000) (7000) (8000) (9000) (10,000)

Pressure - N/M² (PSI)

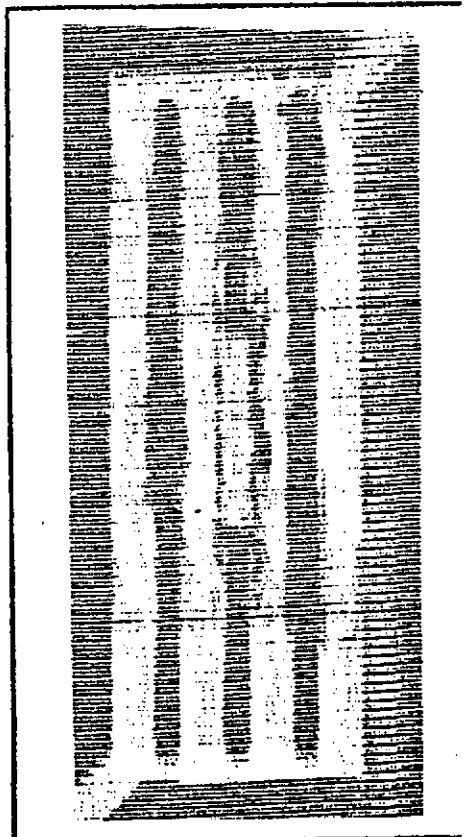
HNDT



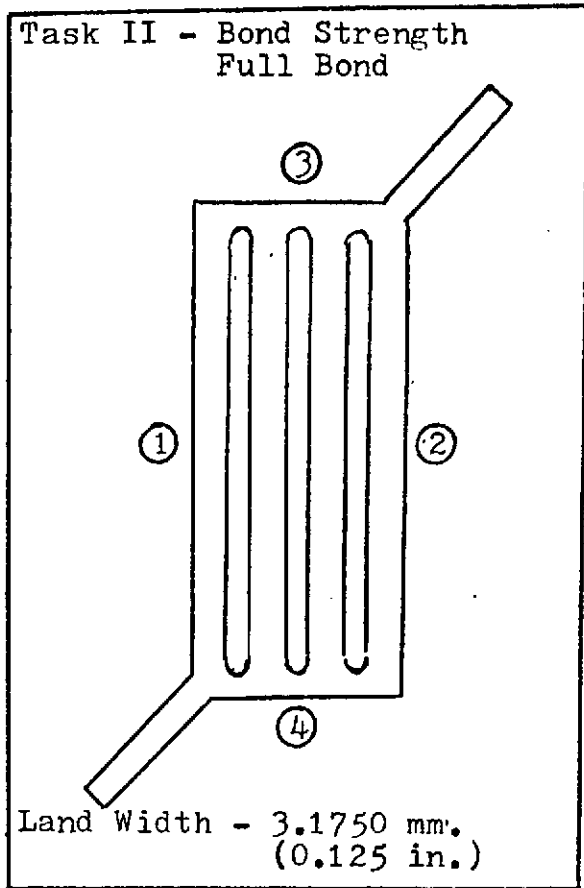
AE
FLAW LOCATOR
CENTER LAND



UT



ELECTROFORMED PANEL NO. C-02C



BASEPLATE

MATERIAL: OFHC Copper

CENTER LAND FLATNESS VARIATION:
0.002 in. (0.0508 mm.)

THICKNESS:	MM.	INCHES
①	6.7259	0.2648
②	6.7310	0.2650
③	6.7310	0.2650
④	6.7310	0.2650

COVERPLATE

MATERIAL: Electroformed Copper

THICKNESS:	MM.	INCHES
①	1.3157	0.0518
②	1.3284	0.0523
③	1.2954	0.0510
④	1.3284	0.0523

PRESSURE REQUIRED TO FAIL BOND:

Bond failed at a pressure of
 $6.38 \times 10^7 \text{ N/m}^2$ (9,250 psi)

CENTER LAND DEFECT

METALLOGRAPHIC ANALYSIS:

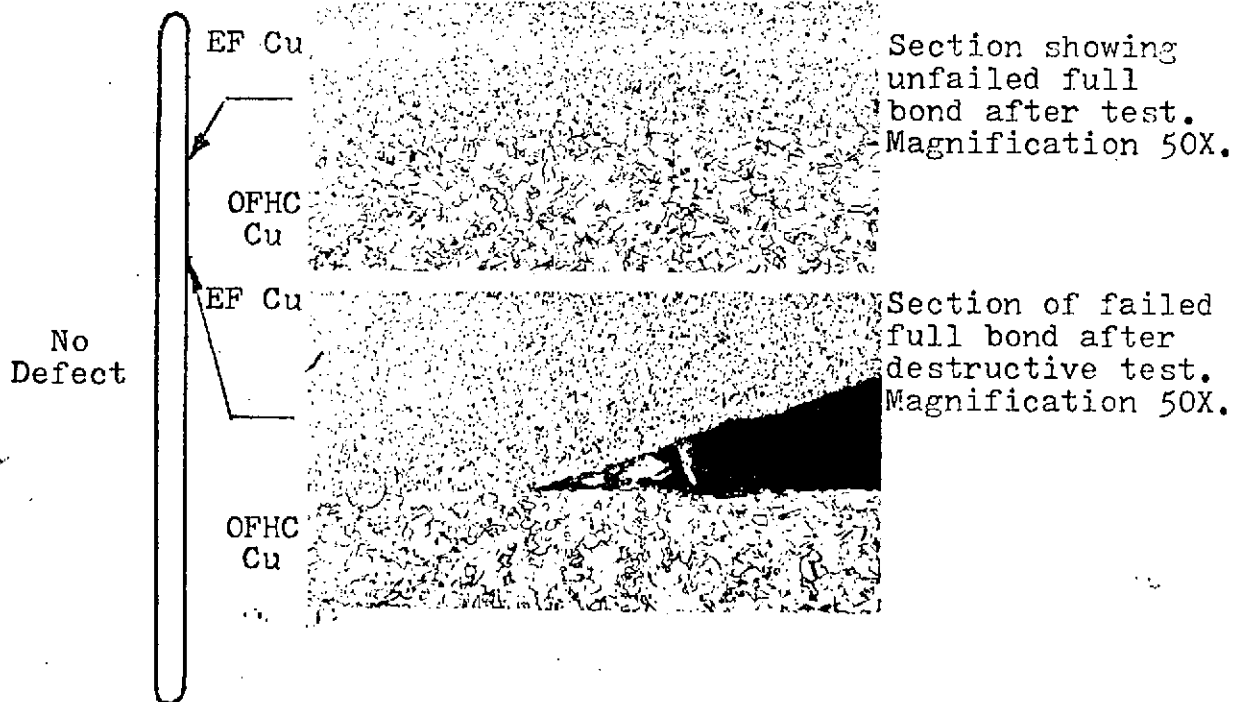
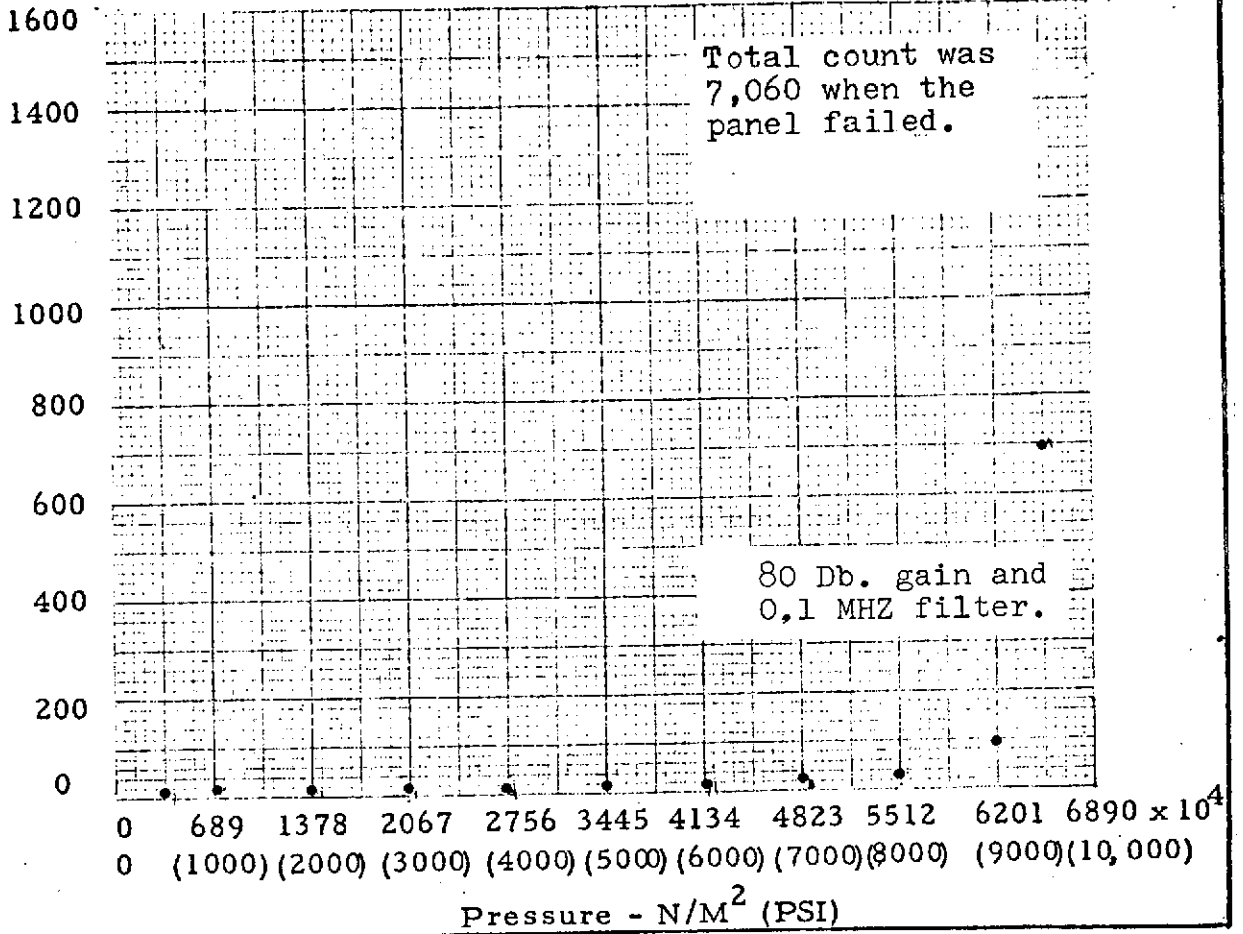


FIGURE A-9

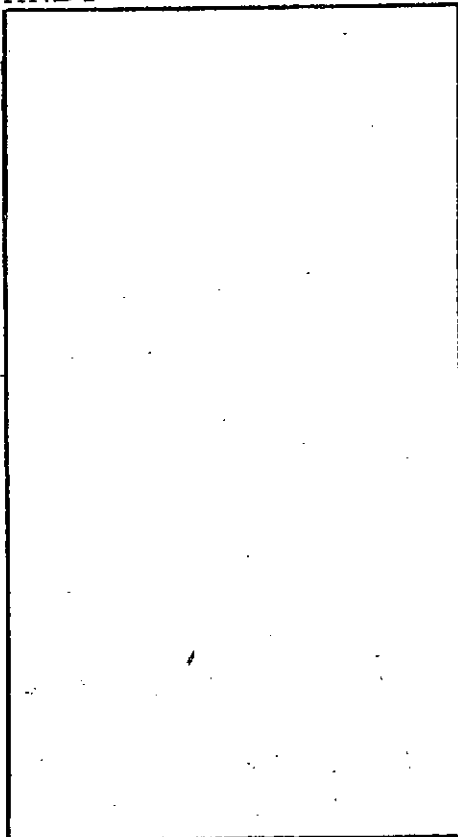
Panel No. C-02C

Summation $\times 10^{-1}$

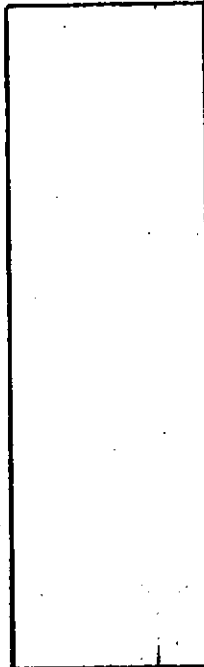
A E



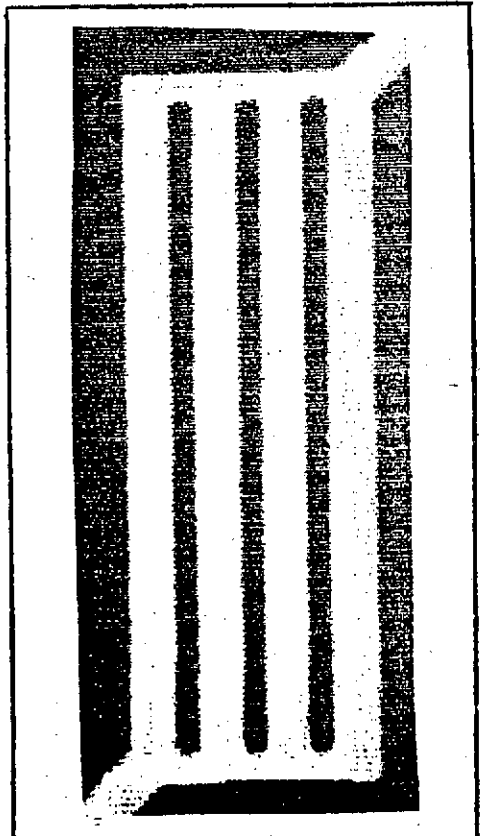
HNDT



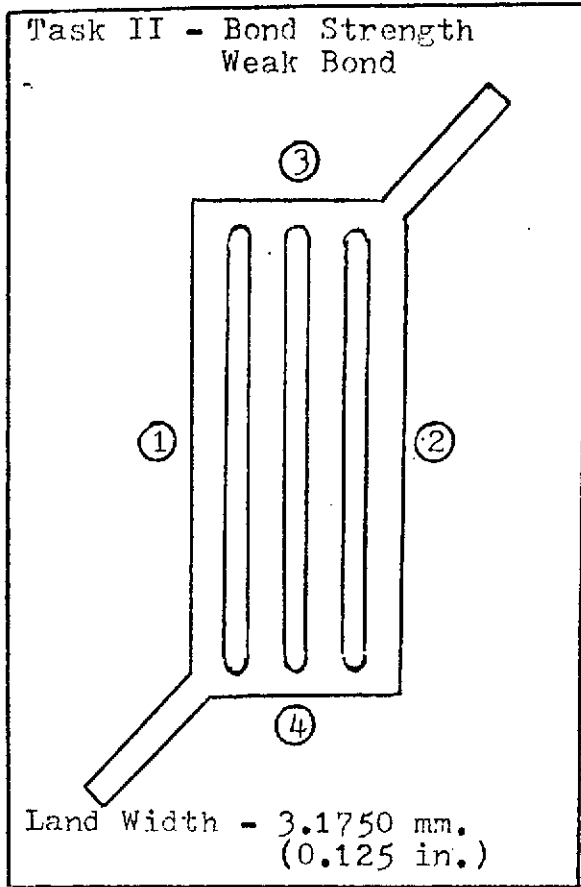
AE
FLAW LOCATOR
CENTER LAND



UT



ELECTROFORMED PANEL NO. C-05C



BASEPLATE

MATERIAL: OFHC Copper

CENTER LAND FLATNESS VARIATION:
0.004 in. (0.1016 mm.)

THICKNESS:	MM.	INCHES
①	6.4262	0.2530
②	6.4745	0.2549
③	6.4719	0.2548
④	6.4186	0.2527

COVERPLATE

MATERIAL: Electroformed Copper

THICKNESS:	MM.	INCHES
①	1.2929	0.0509
②	1.2268	0.0483
③	1.2421	0.0489
④	1.2827	0.0505

PRESSURE REQUIRED TO FAIL BOND:

Bond failed at a pressure of
 $1.86 \times 10^7 \text{ N/m}^2$ (2,700 psi)

CENTER LAND DEFECT

METALLOGRAPHIC ANALYSIS:

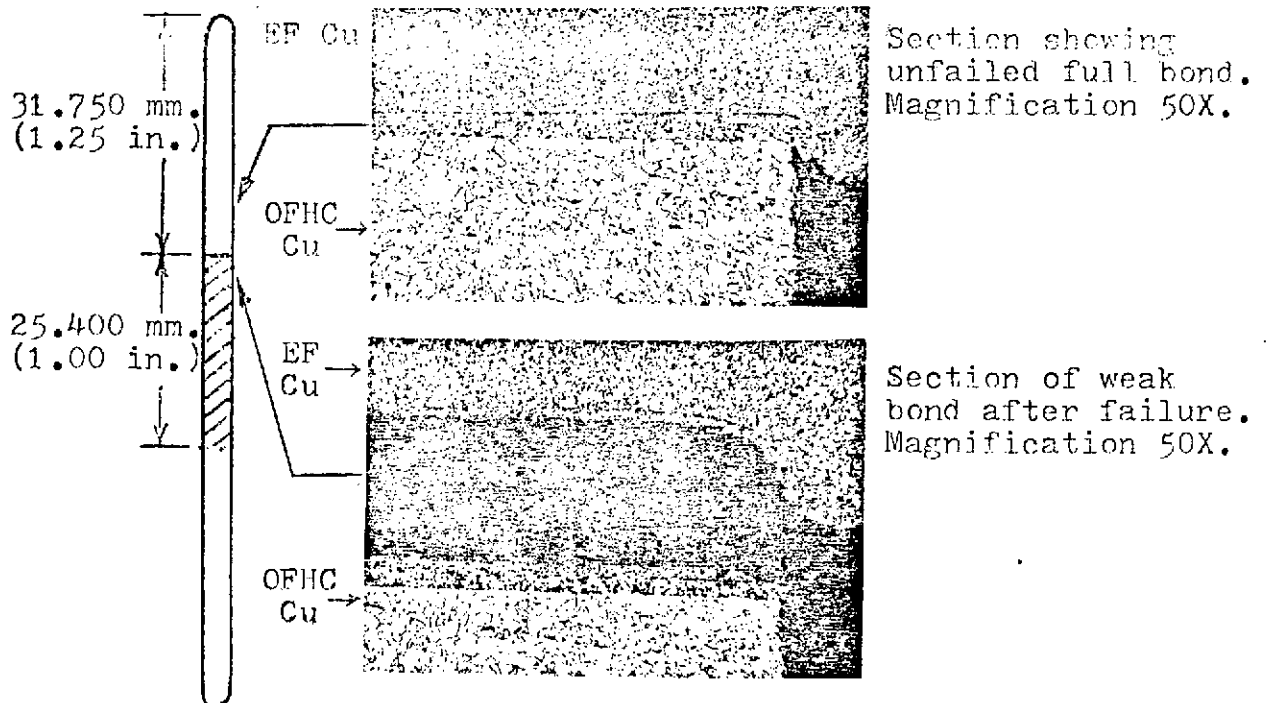
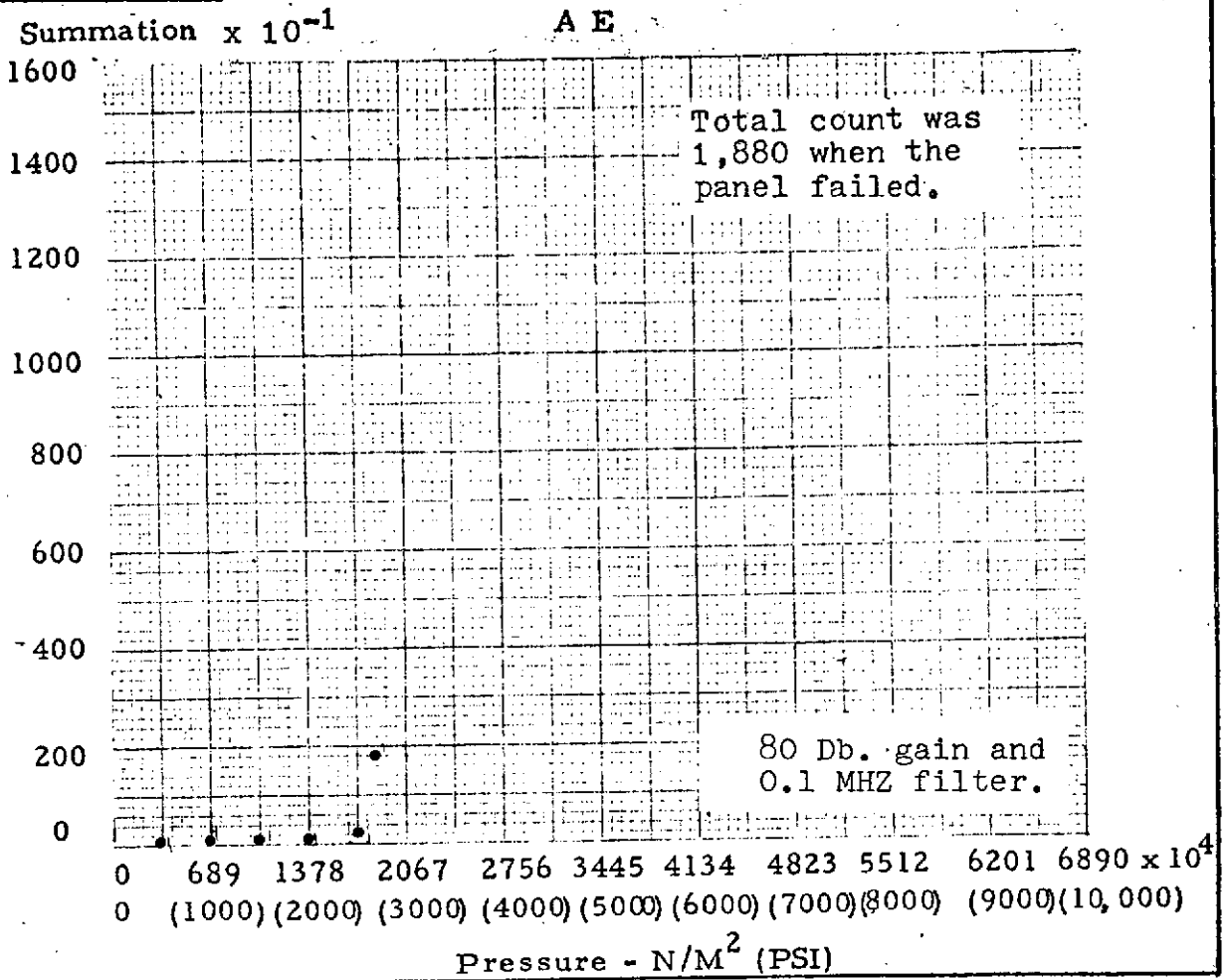
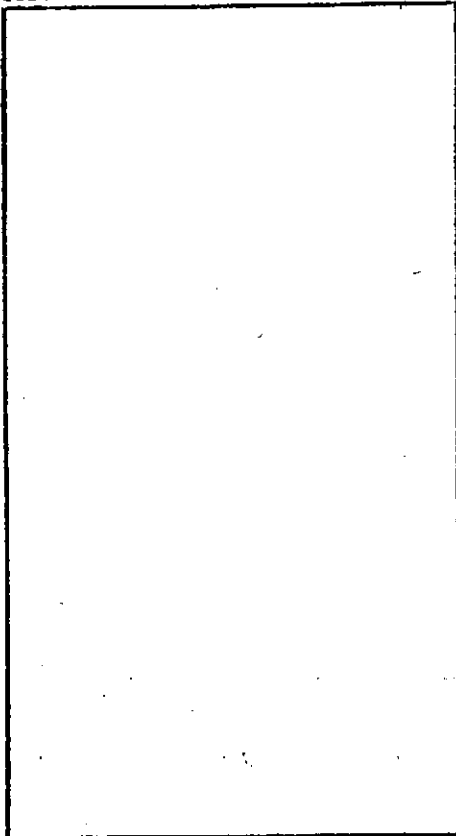


FIGURE A-10

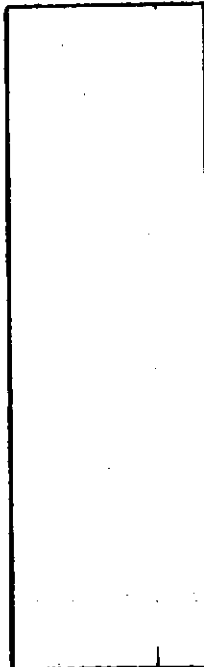
Panel No. C-05C



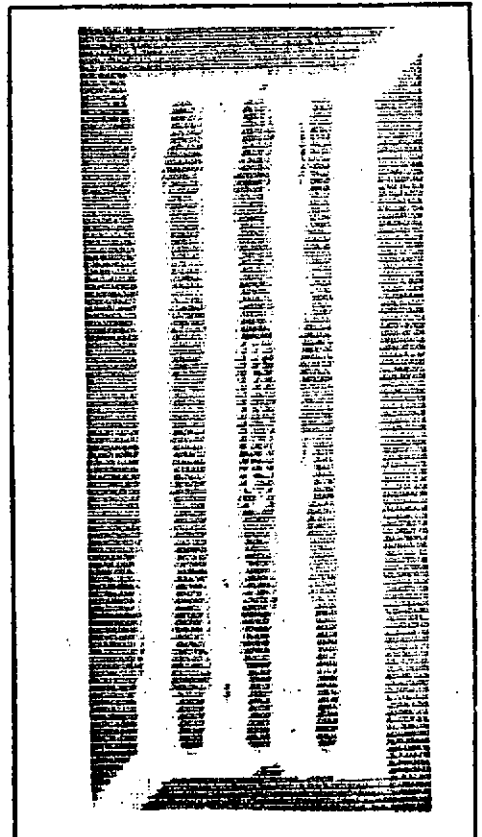
HNDT



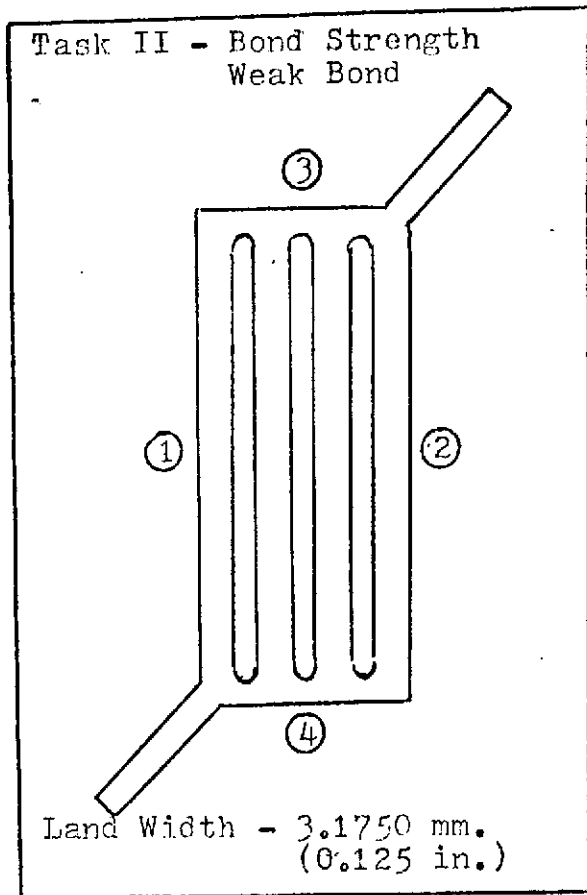
AE
FLAW LOCATOR
CENTER LAND



UT



ELECTROFORMED PANEL NO. C-10C



BASEPLATE

MATERIAL: OFHC Copper
CENTER LAND FLATNESS VARIATION:
0.003 in. (0.0762 mm.)

THICKNESS:	MM.	INCHES
①	6.5735	0.2588
②	6.5735	0.2588
③	6.6269	0.2609
④	6.5303	0.2571

COVERPLATE

MATERIAL: Electroformed Copper

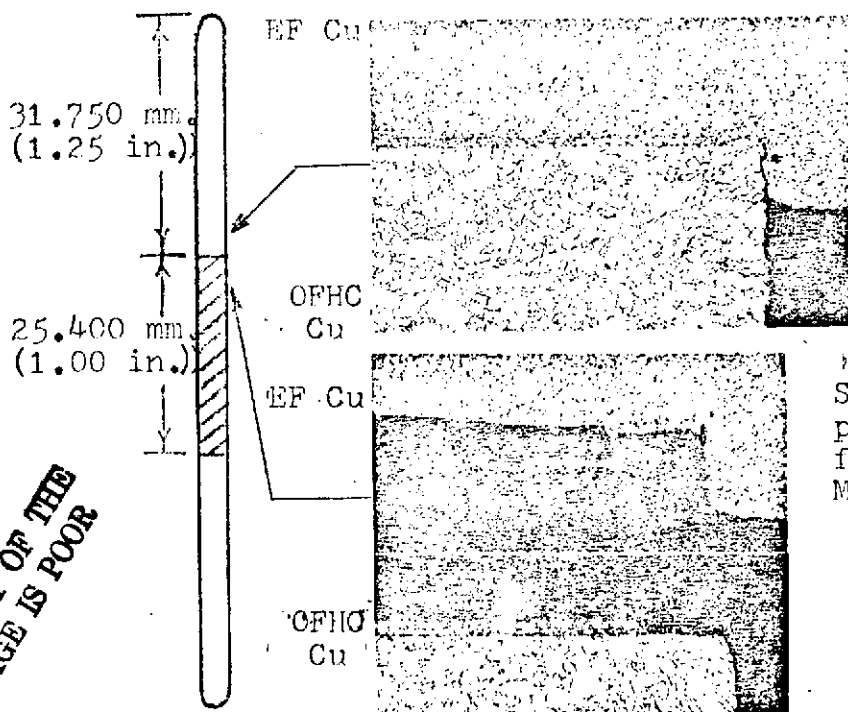
THICKNESS:	MM.	INCHES
①	1.2852	0.0506
②	1.3157	0.0518
③	1.2700	0.0500
④	1.3589	0.0535

PRESSURE REQUIRED TO FAIL BOND:

Bond failed at a pressure of
 3.80×10^7 N/m² (5,500 psi)

CENTER LAND DEFECT

METALLOGRAPHIC ANALYSIS:



Full bond area of
land showing no
bond failure.
Magnification 50X.

Section of weak bond
planned defect. Bond
failure occurred.
Magnification 50X.

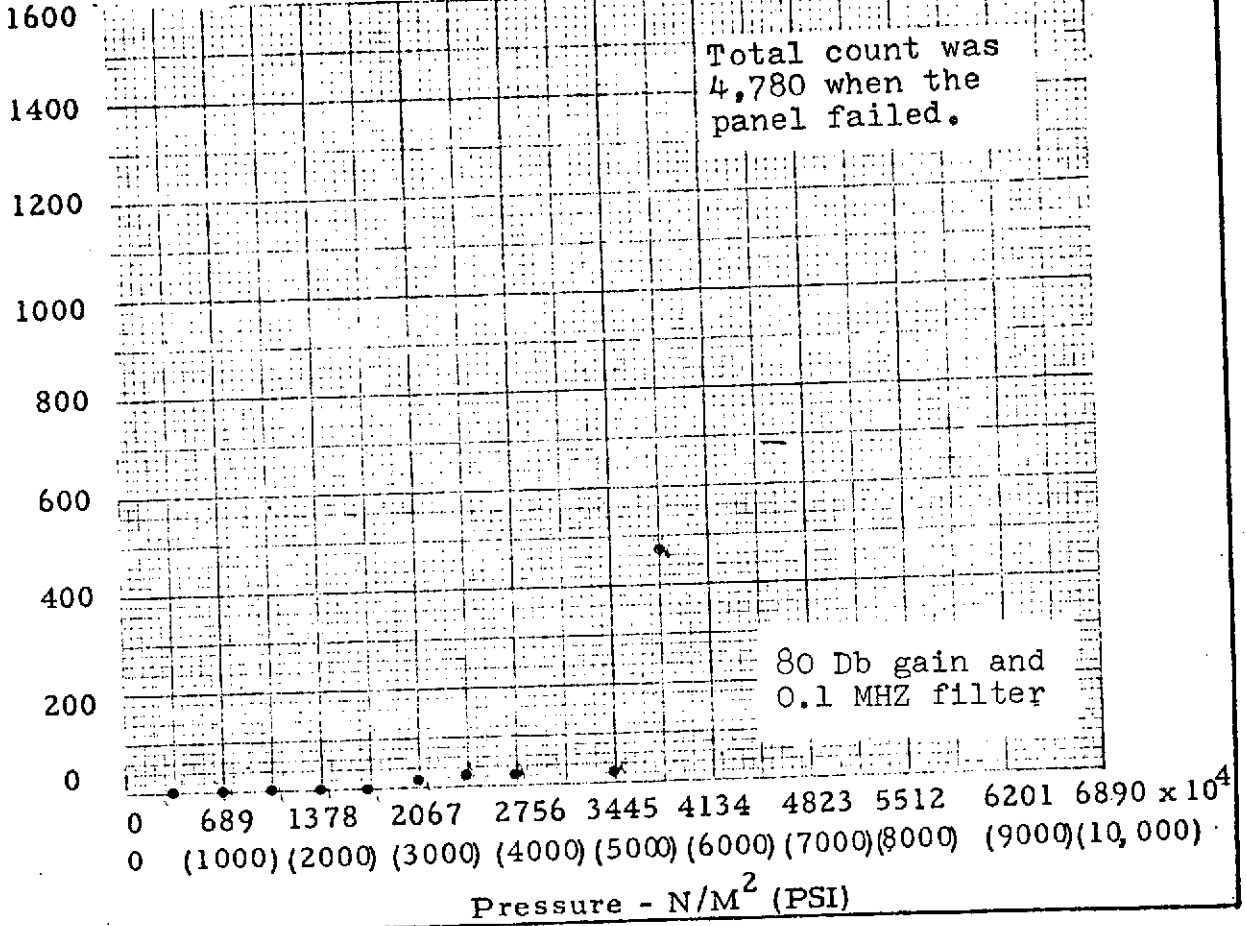
FIGURE A-11

REPRODUCIBILITY OF THE
ORIGINAL PAGE IS POOR

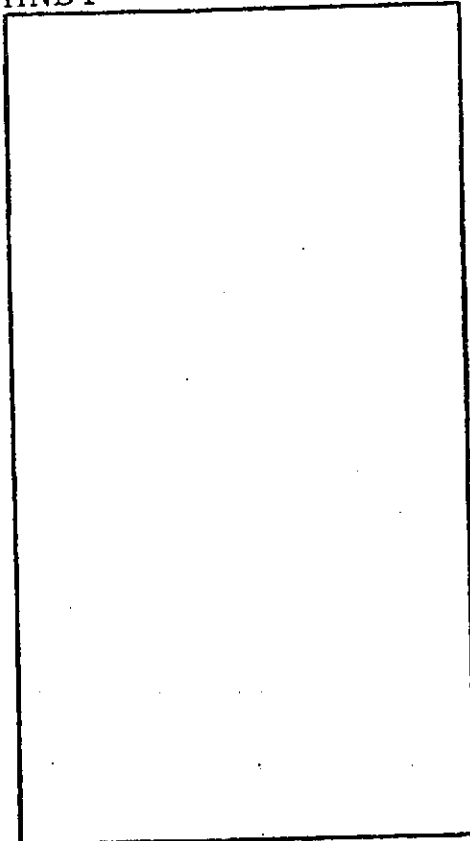
Panel No. C-10C

Summation x 10⁻¹

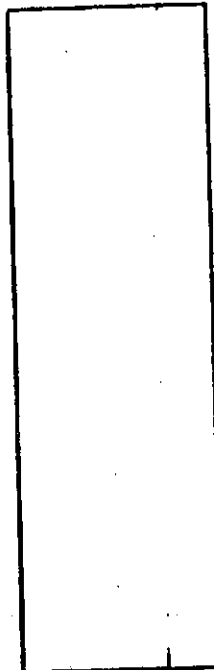
A E



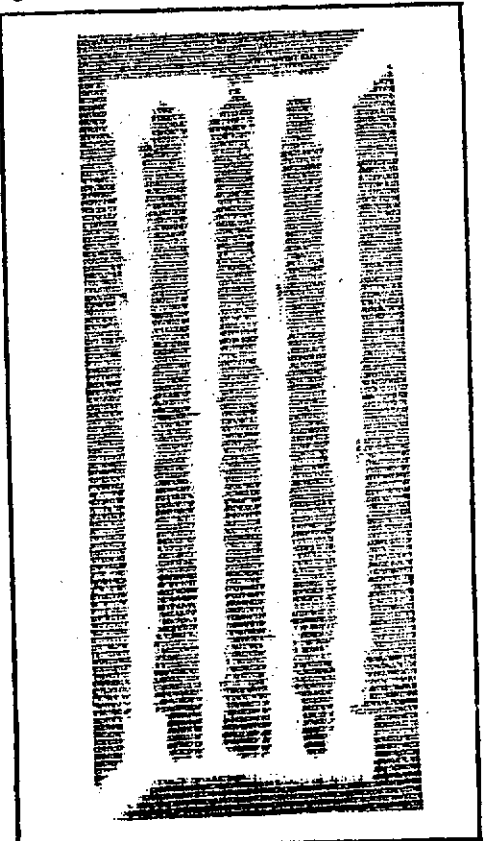
HNDT



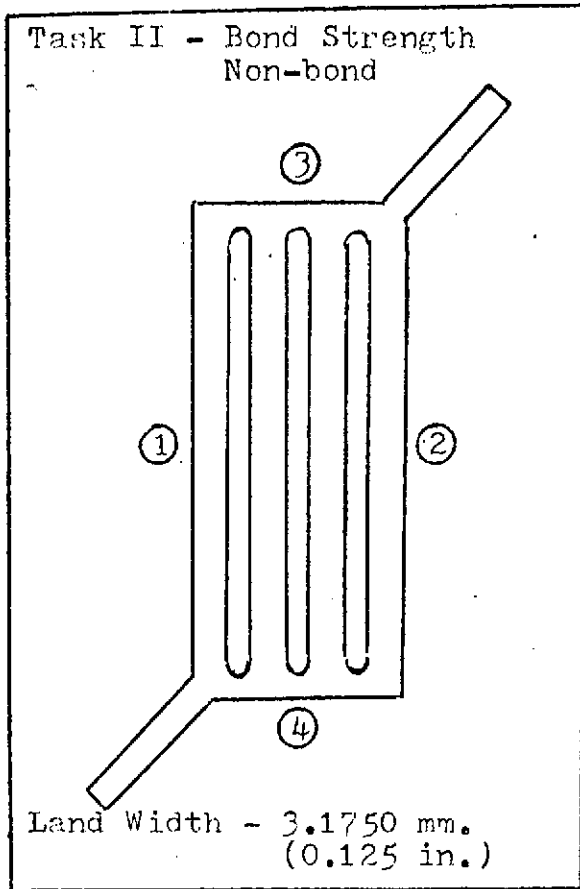
AE
FLAW LOCATOR
CENTER LAND



UT



ELECTROFORMED PANEL NO. C-11C



BASEPLATE

MATERIAL: OFHC Copper

CENTER LAND FLATNESS VARIATION:
0.003 in. (0.0762 mm.)

THICKNESS:	MM.	INCHES
①	6.5380	0.2574
②	6.6040	0.2600
③	6.5811	0.2591
④	6.5913	0.2595

COVERPLATE

MATERIAL: Electroformed Copper

THICKNESS:	MM.	INCHES
①	1.3233	0.0521
②	1.2776	0.0503
③	1.2624	0.0497
④	1.2675	0.0499

PRESSURE REQUIRED TO FAIL BOND:

Bond failed at a pressure of
 $1.04 \times 10^7 \text{ N/m}^2$ (1,500 psi)

CENTER LAND DEFECT

METALLOGRAPHIC ANALYSIS:

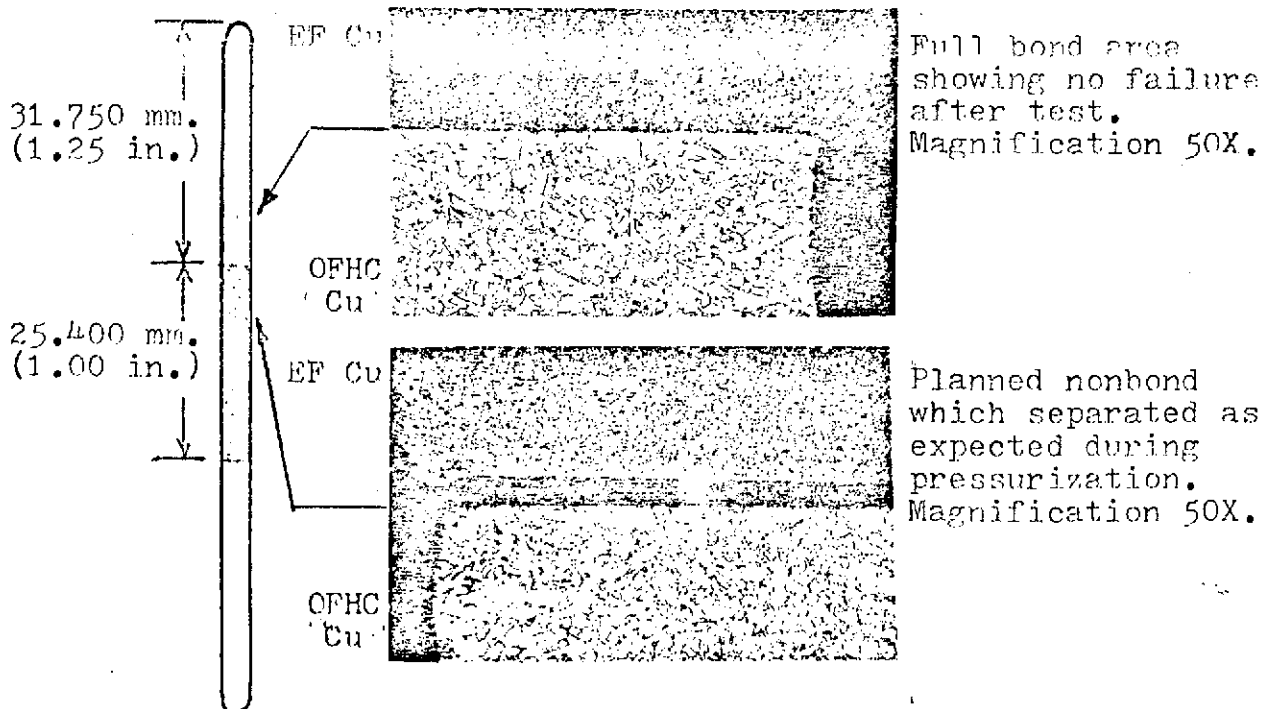
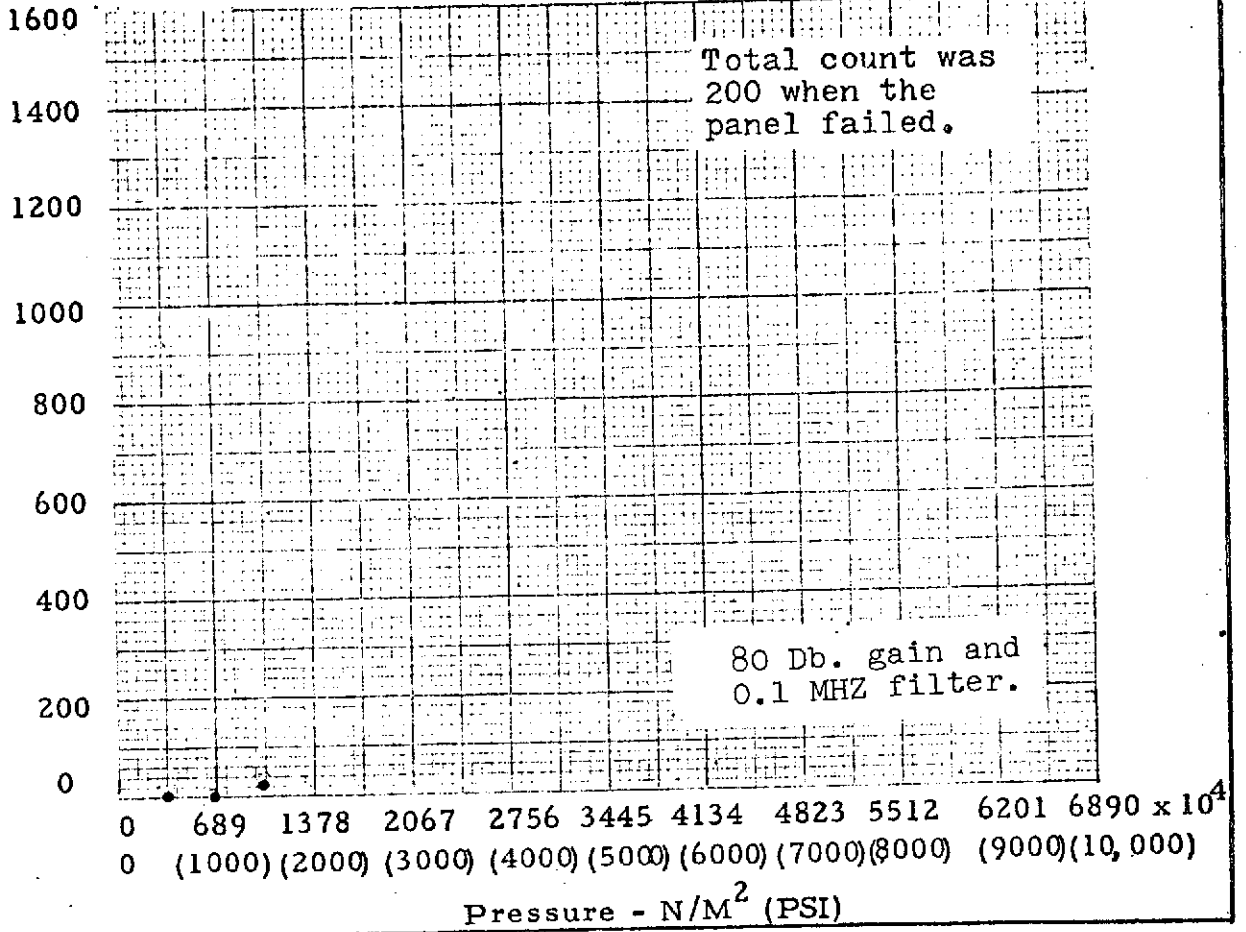


FIGURE A-12

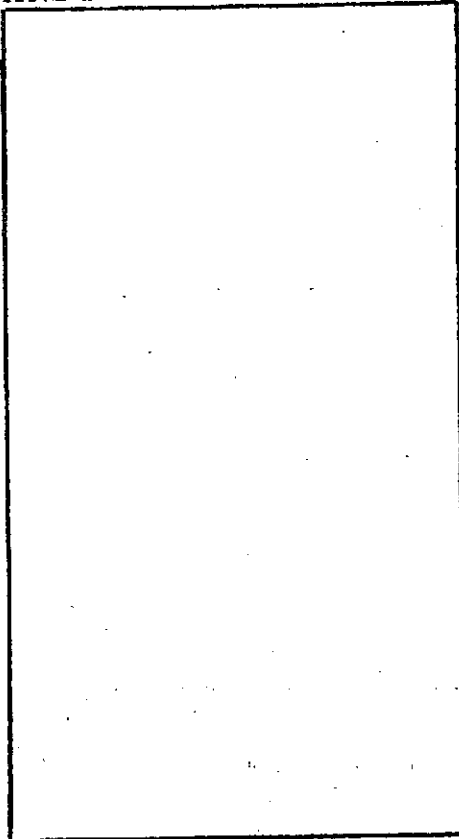
Panel No. C-11C

Summation x 10⁻¹

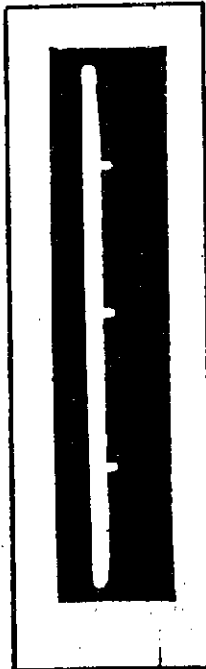
A E



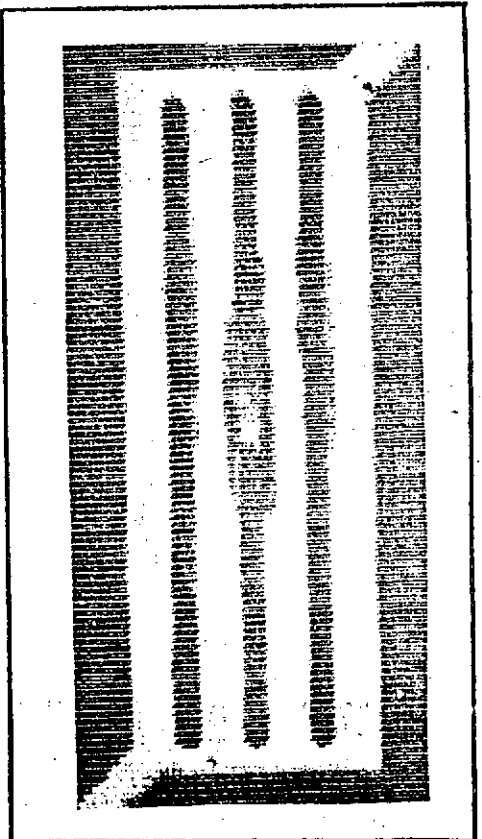
HNDT



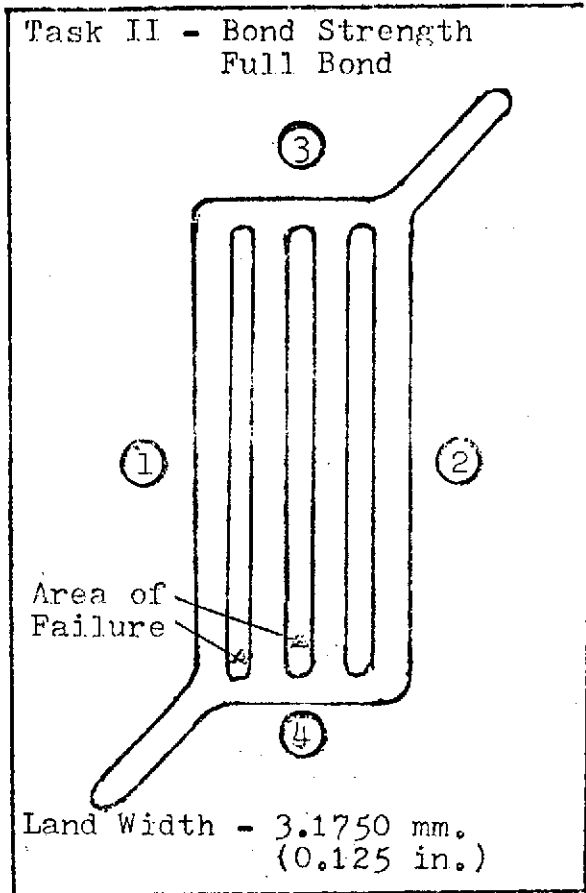
AE
FLAW LOCATOR
CENTER LAND



UT



BRAZED PANEL NO. B-03



BASEPLATE

MATERIAL: OFHC Copper

THICKNESS:	MM.	INCHES
①	6.5735	0.2588
②	6.5405	0.2575
③	6.5913	0.2595
④	6.5126	0.2564

COVERPLATE

MATERIAL: 304L Stainless Steel

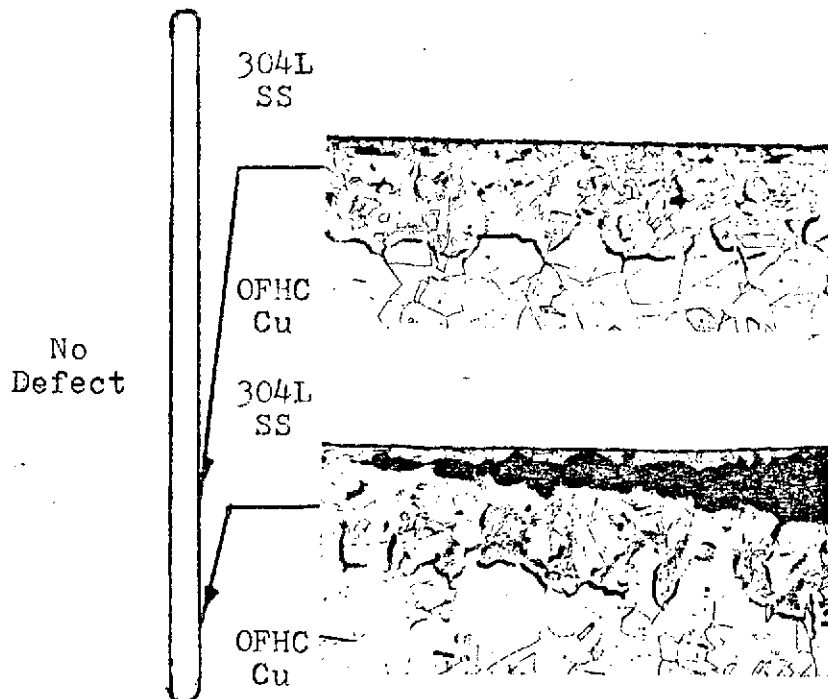
THICKNESS:	MM.	INCHES
①	1.2243	0.0482
②	1.2268	0.0483
③	1.2268	0.0483
④	1.2243	0.0482

PRESSURE REQUIRED TO FAIL BOND:

Panel failed at a pressure of $2.76 \times 10^7 \text{ N/m}^2$ (4,000 psi).

CENTER LAND DEFECT

METALLOGRAPHIC ANALYSIS:

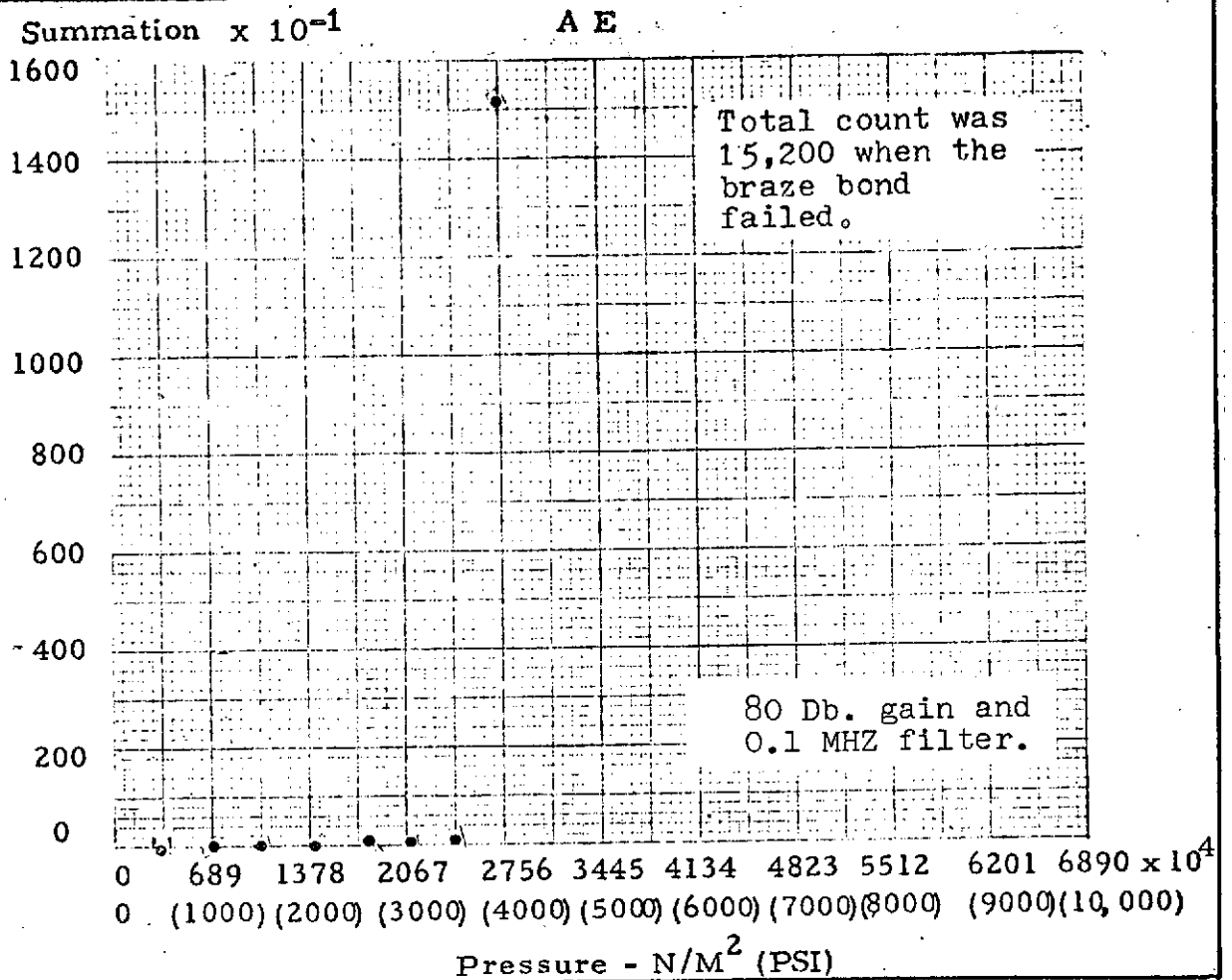


Full bond showing no failure. Note small voids in the braze layer. Magnification 50X.

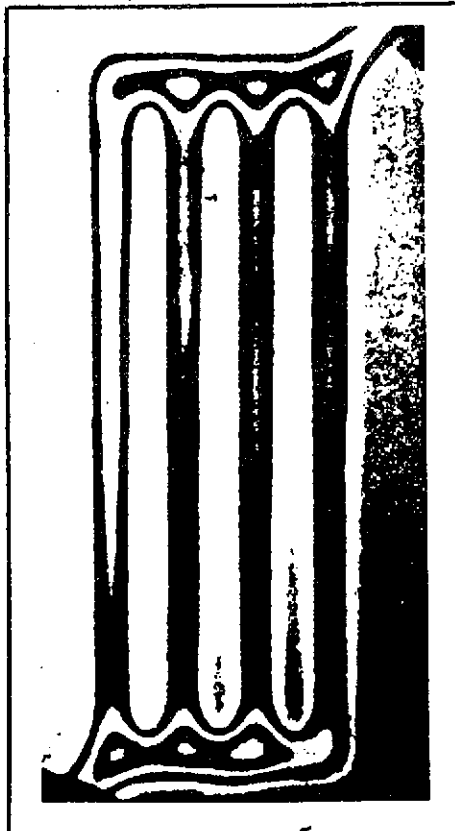
Bond failure section illustrates separation occurred through the braze alloy. Magnification 50X.

FIGURE A-13

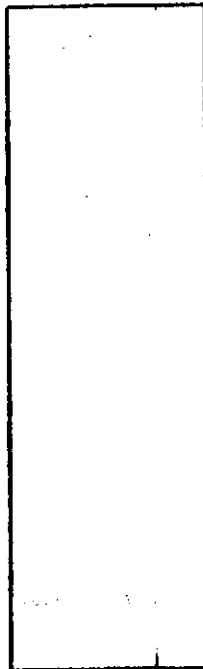
Panel No. B-03



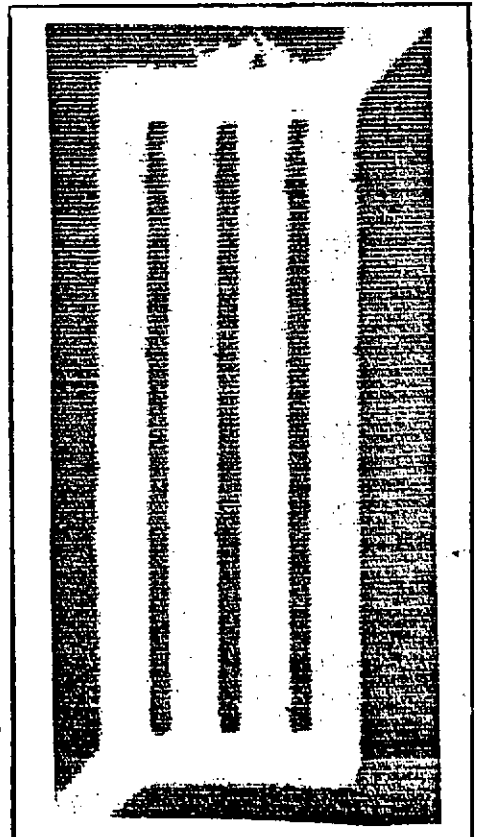
HNDT (Before AE)



AE
FLAW LOCATOR
CENTER LAND

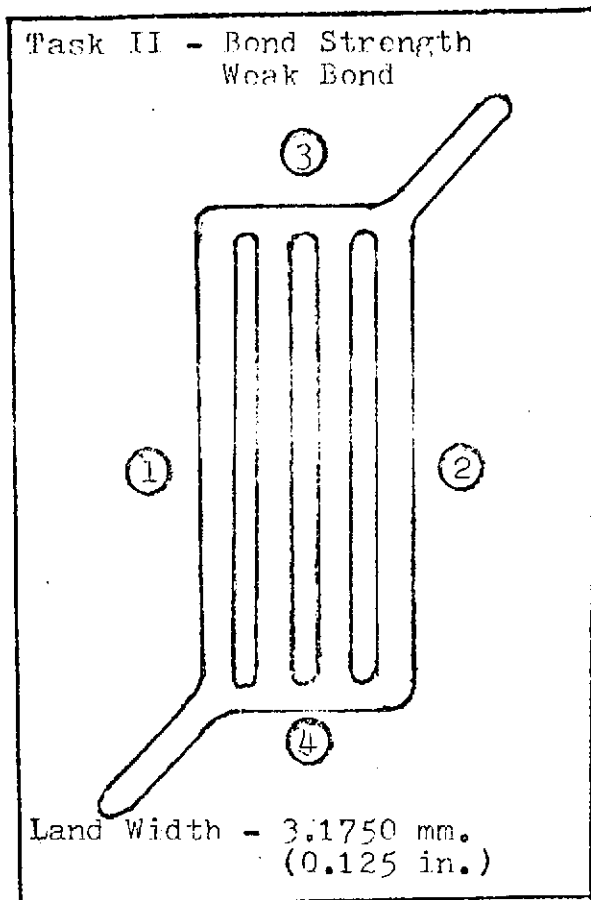


UT



Press. $6.9 \times 10^5 N/M^2$
(100 PSI)

BRAZED PANEL NO. B-07



BASEPLATE

MATERIAL: OFHC Copper

THICKNESS:	MM.	INCHES
①	6.6497	0.2618
②	6.6599	0.2622
③	6.6650	0.2624
④	6.6878	0.2633

COVERPLATE

MATERIAL: 304L Stainless Steel

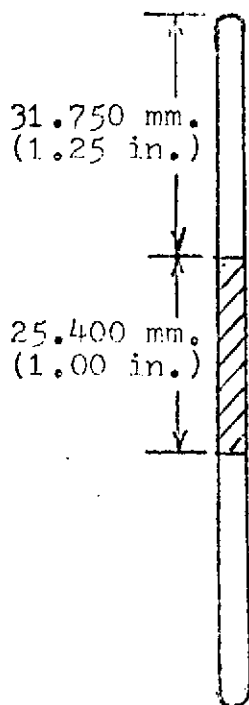
THICKNESS:	MM.	INCHES
①	1.2217	0.0481
②	1.2217	0.0481
③	1.2243	0.0482
④	1.2217	0.0481

PRESSURE REQUIRED TO FAIL BOND:

Bond failed at a pressure of $3.66 \times 10^7 \text{ N/m}^2$ (5,300 psi).
Coverplate actually buckled without bond failure.

CENTER LAND DEFECT

METALLOGRAPHIC ANALYSIS:

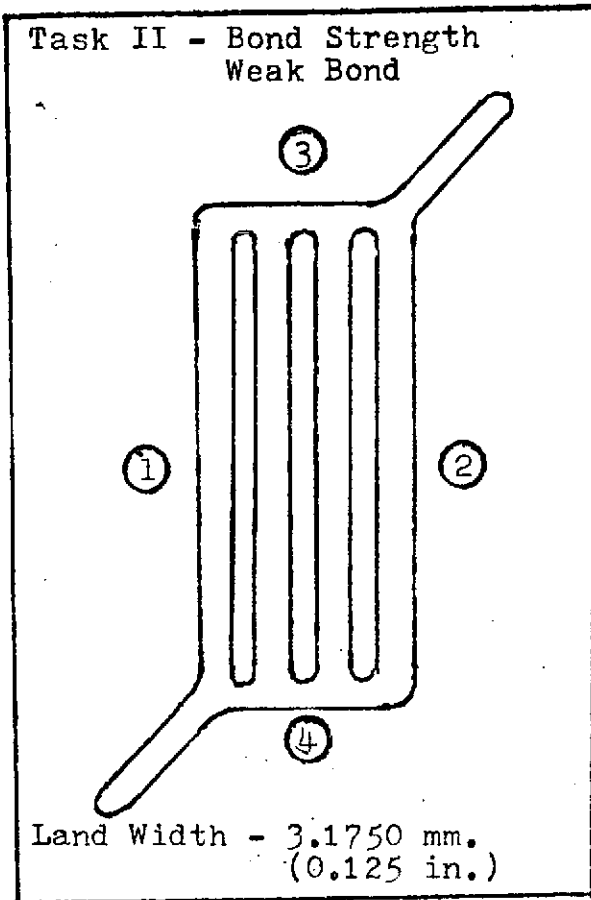


This panel was not sectioned for metallurgical examination. The process used to produce the weak bond actually resulted in a full braze bond. See Panel B-10, Figure A-15, for results of the process selected.

REPRODUCIBILITY OF THE ORIGINAL PAGE IS POOR

FIGURE A-14

BRAZED PANEL NO. B-10



BASEPLATE

MATERIAL: OFHC Copper

THICKNESS:	MM.	INCHES
①	6.5532	0.2580
②	6.5227	0.2568
③	6.6675	0.2625
④	6.6192	0.2606

COVERPLATE

MATERIAL: 304L Stainless Steel

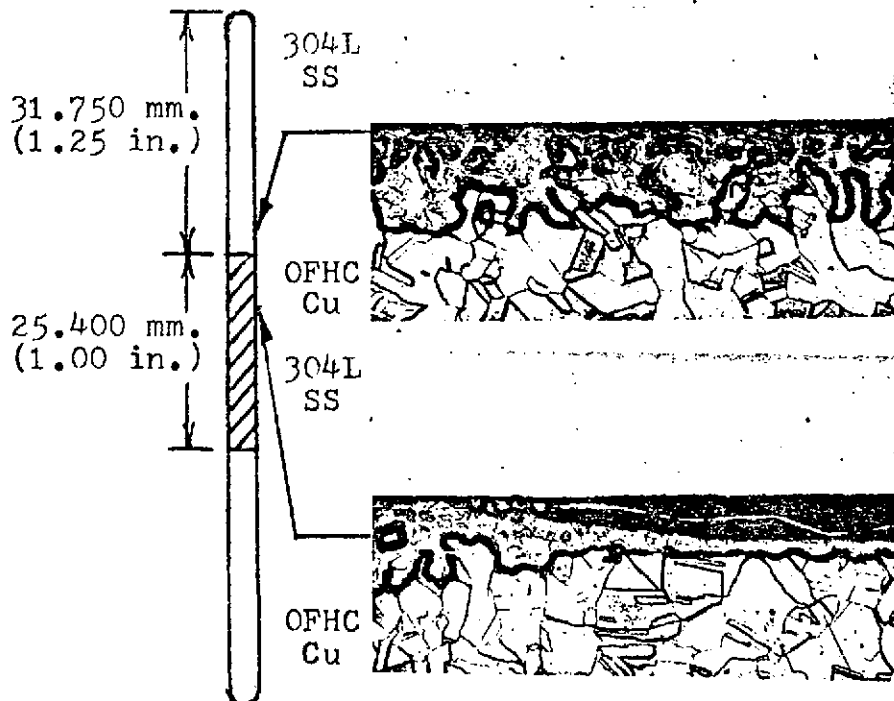
THICKNESS:	MM.	INCHES
①	1.2243	0.0482
②	1.2268	0.0483
③	1.2268	0.0483
④	1.2268	0.0483

PRESSURE REQUIRED TO FAIL BOND:

Bond failed at a pressure of 1.28×10^7 N/m² (1,850 psi).

CENTER LAND DEFECT

METALLOGRAPHIC ANALYSIS:

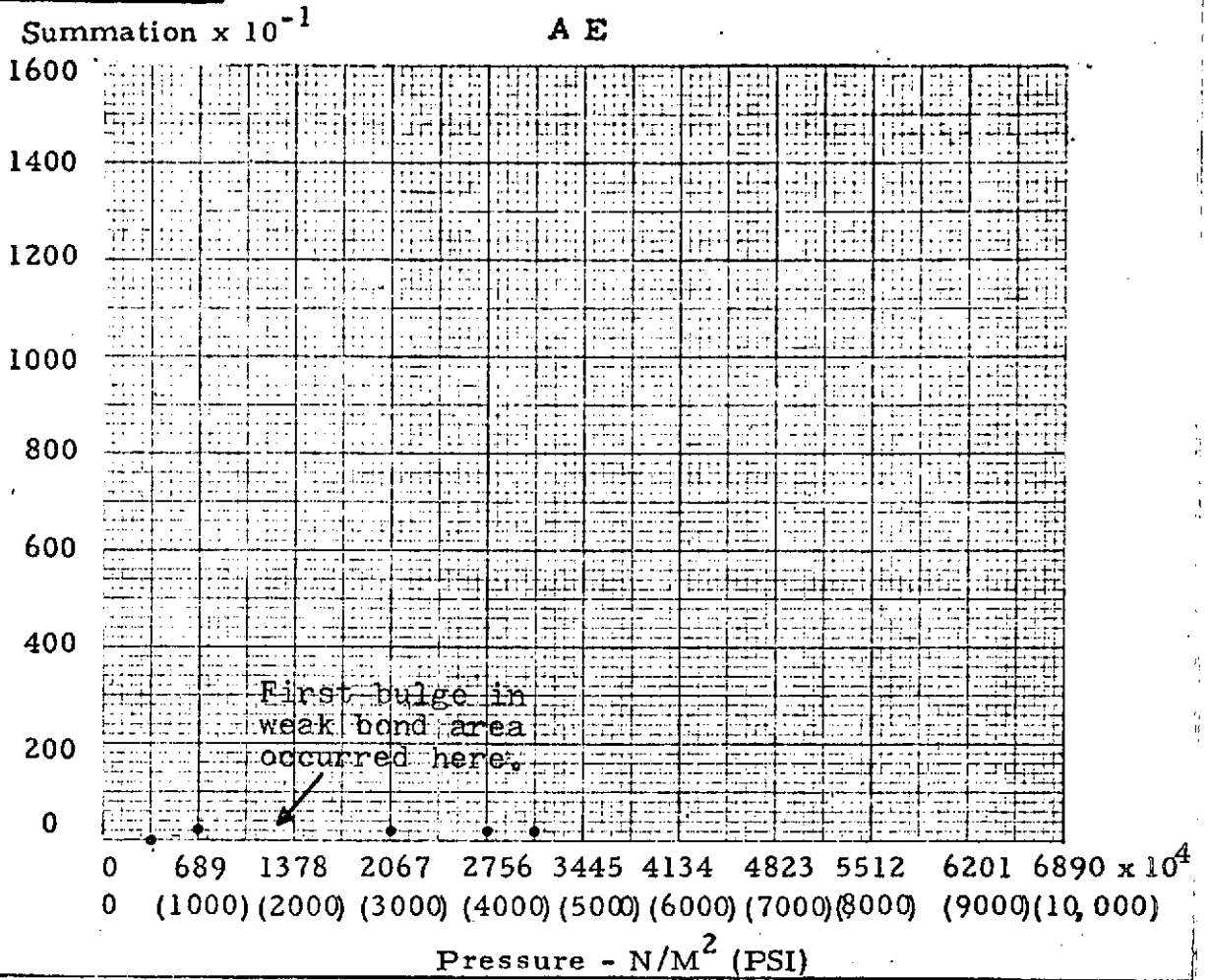


Section showing full bond adjacent to the planned weak bond. Magnification 50X.

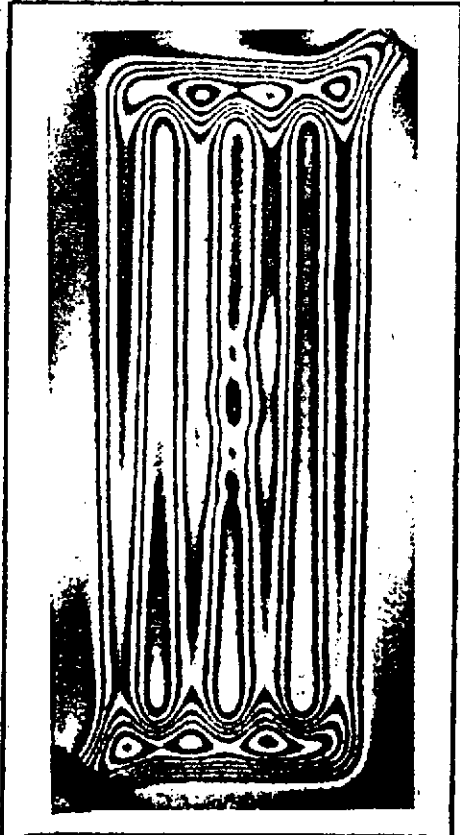
Section from the planned weak bond area showing regions of poor braze wetting of the Stainless coverplate. Magnification 50X.

FIGURE A-15

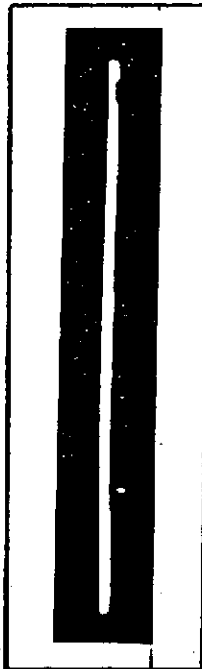
Panel No. B-10



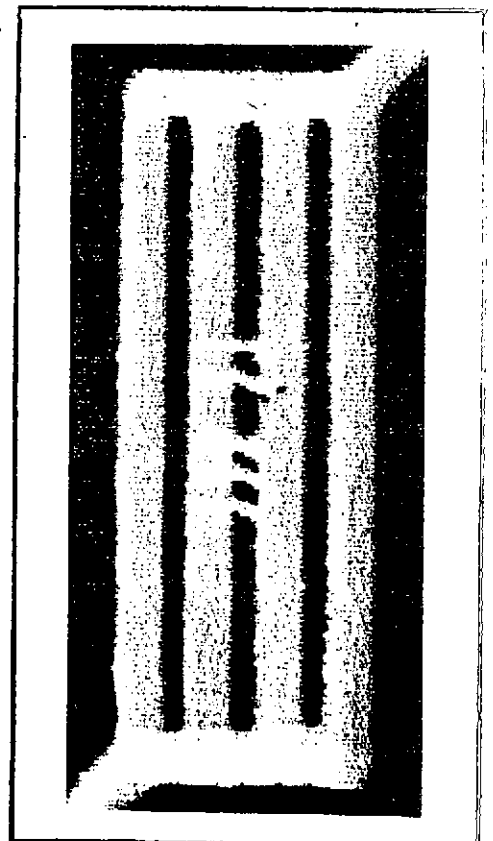
HNDT (Before AE)



AE
FLAW LOCATOR
CENTER LAND

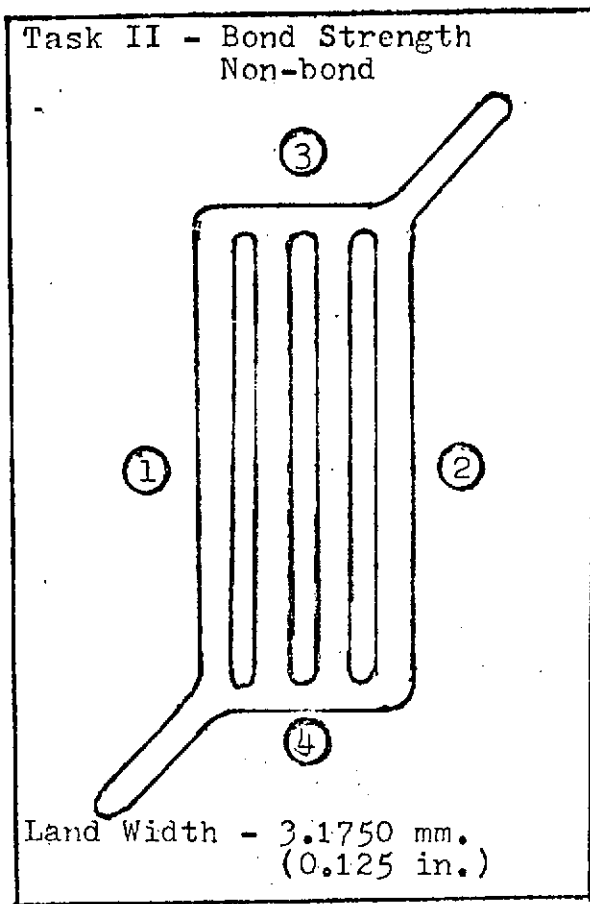


UT



Press. - $20.7 \times 10^5 N/M^2$
(300 PSI)

BRAZED PANEL NO. B-05



BASEPLATE

MATERIAL: OFHC Copper

THICKNESS:	MM.	INCHES
①	6.6523	0.2619
②	6.7183	0.2645
③	6.6396	0.2614
④	6.6777	0.2629

COVERPLATE

MATERIAL: 304L Stainless Steel

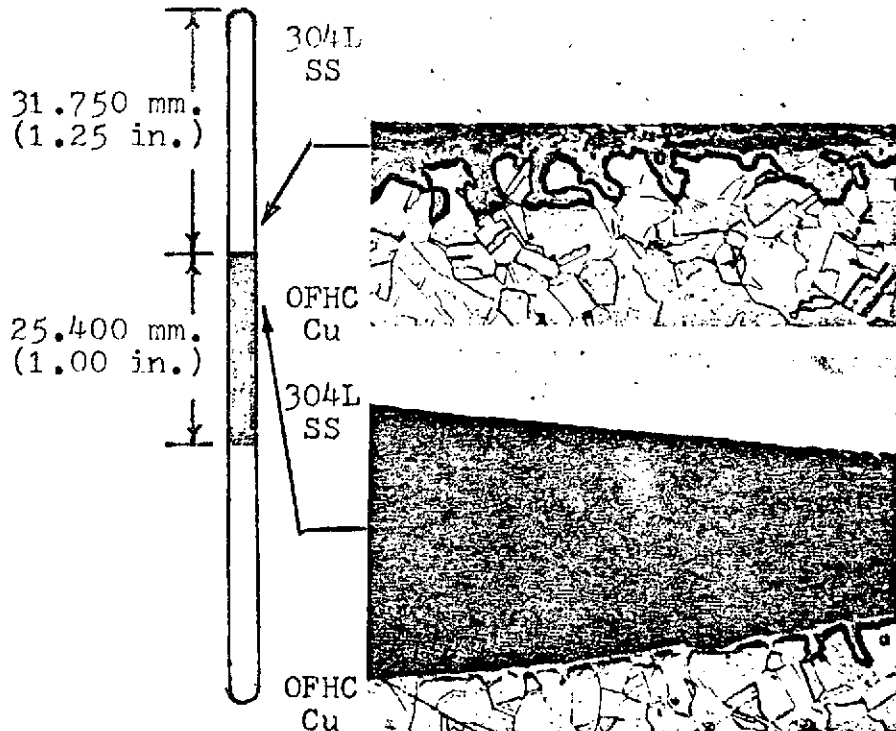
THICKNESS:	MM.	INCHES
①	1.2268	0.0483
②	1.2268	0.0483
③	1.2243	0.0482
④	1.2268	0.0483

PRESSURE REQUIRED TO FAIL BOND:

Panel failed at a pressure of 0.83×10^7 N/m² (1,200 psi).

CENTER LAND DEFECT

METALLOGRAPHIC ANALYSIS:



Section from full bond adjacent to the planned non-bond. Some braze failure was initiated. Magnification 50X.

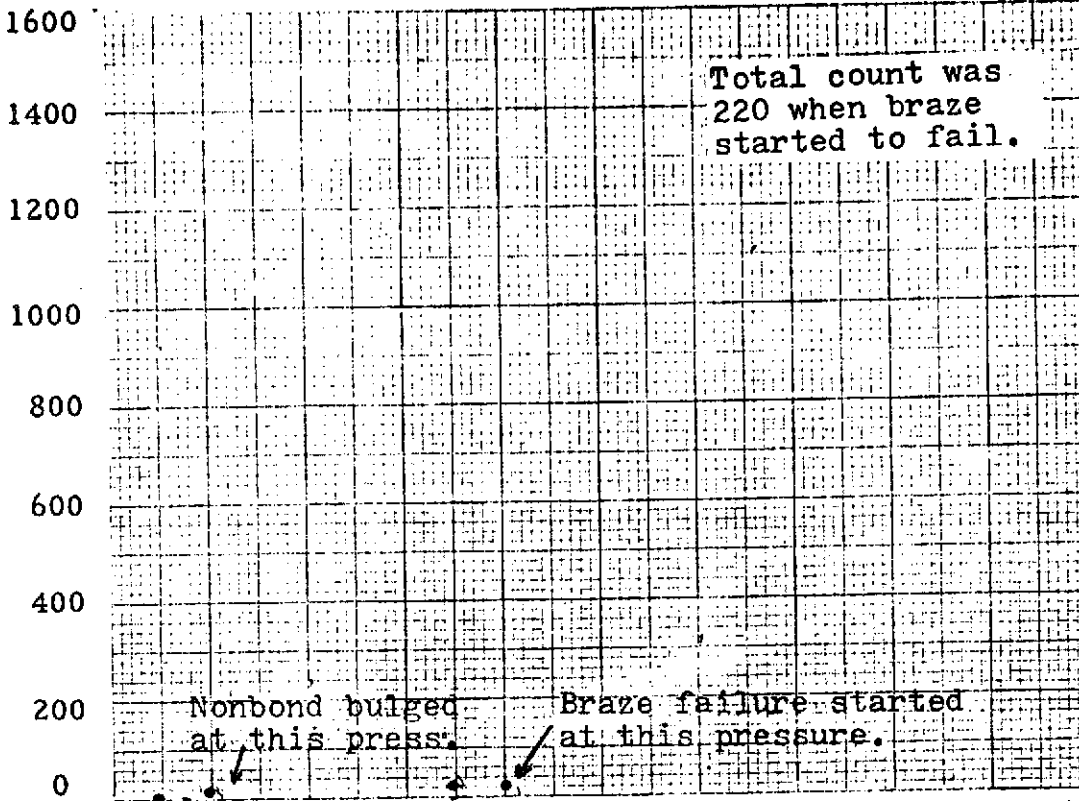
Illustration of separation which occurred in the planned nonbond. Magnification 50X.

FIGURE A-16

Panel No. B-05

Summation $\times 10^{-1}$

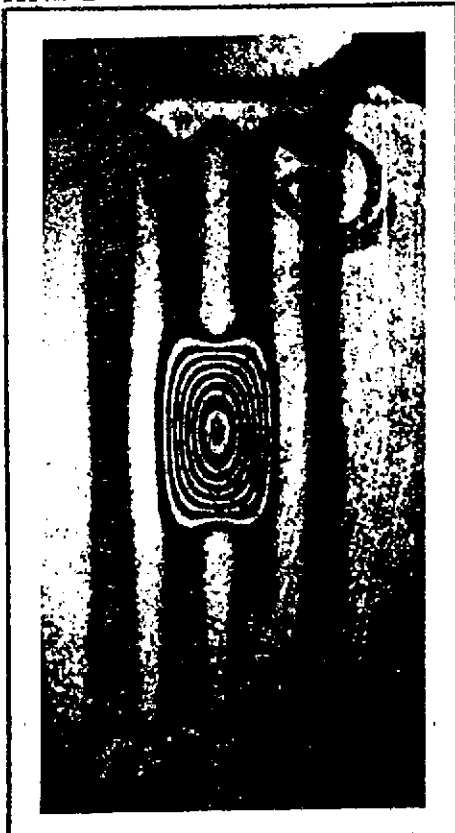
A E



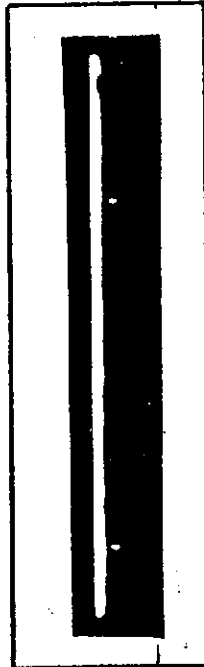
0 689 1378 2067 2756 3445 4134 4823 5512 6201 6890 $\times 10^4$
 0 (1000) (2000) (3000) (4000) (5000) (6000) (7000) (8000) (9000) (10,000)

Pressure - N/M^2 (PSI)

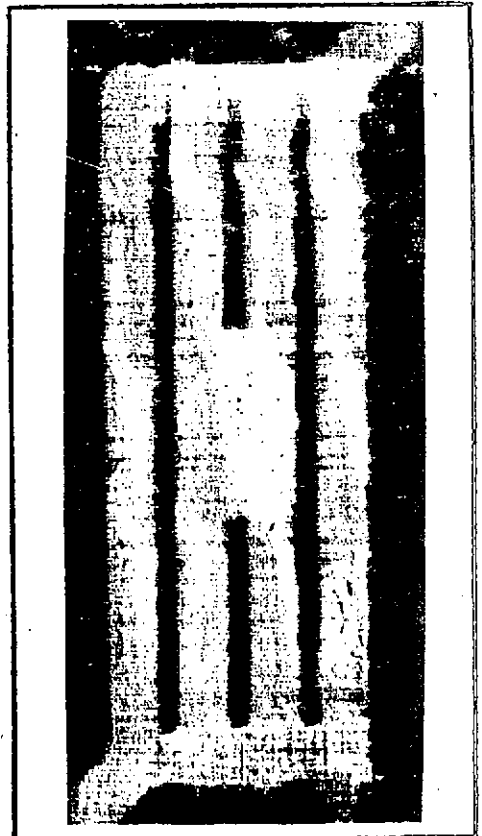
HNDT (Before AE)



AE
FLAW LOCATOR
CENTER LAND

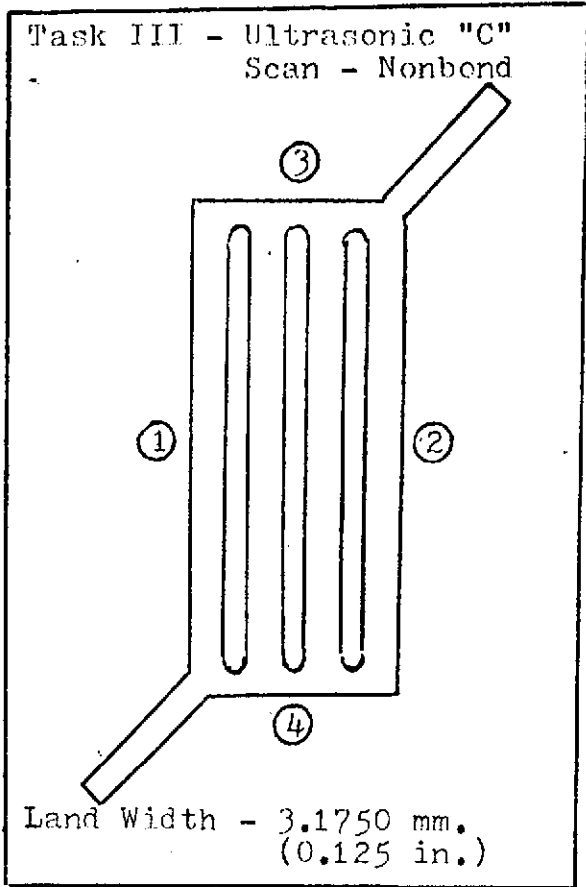


UT



Press. $3.45 \times 10^5 N/M^2$
(50 PSI)

ELECTROFORMED PANEL NO. N-14



BASEPLATE

MATERIAL: Nickel 200

CENTER LAND FLATNESS VARIATION:
0.003 in (0.0762 mm.)

THICKNESS:	MM.	INCHES
①	6.2789	0.2472
②	6.2763	0.2471
③	6.2738	0.2470
④	6.2713	0.2469

COVERPLATE

MATERIAL: Electroformed Nickel

THICKNESS:	MM.	INCHES
①	0.4978	0.0196
②	0.5055	0.0199
③	0.5105	0.0201
④	0.5359	0.0211

CENTER LAND DEFECT

METALLOGRAPHIC ANALYSIS: Not Applicable

12.700 mm. (0.50 in.)	Slot	3.1496 mm.	(0.124 in.)
	Space	3.2004 mm.	(0.126 in.)
12.700 mm. (0.50 in.)	Slot	3.1750 mm.	(0.125 in.)
	Slot	1.6256 mm.	(0.064 in.)
	Space	1.6256 mm.	(0.064 in.)
12.700 mm. (0.50 in.)	Slot	1.6510 mm.	(0.065 in.)
	Slot	0.7620 mm.	(0.030 in.)
	Space	0.8890 mm.	(0.035 in.)
12.700 mm. (0.50 in.)	Slot	0.7620 mm.	(0.030 in.)
	Slot	0.1016 mm.	(0.004 in.)
	Space	0.1524 mm.	(0.006 in.)
12.700 mm. (0.50 in.)	Slot	0.1016 mm.	(0.004 in.)
	Slot	0.2032 mm.	(0.008 in.)
	Space	0.7112 mm.	(0.028 in.)
12.700 mm. (0.50 in.)	Slot	0.2032 mm.	(0.008 in.)
	Slot	0.3810 mm.	(0.015 in.)
	Space	0.3302 mm.	(0.013 in.)
12.700 mm. (0.50 in.)	Slot	0.4064 mm.	(0.016 in.)

All slots were produced by electric discharge machining to a depth of 0.254 mm. (0.010 in.)

FIGURE B-1

ULTRASONIC "C" SCAN STANDARD

PANEL N-14, COVERPLATE THICKNESS 0.5080 mm. (0.020 in.)

PULSE ECHO METHOD

50 W Pulser Re-
ceiver

20 MHZ Medium
Focused Transducer

PULSE ECHO METHOD

HRL Pulser Receiver

20 MHZ Medium
Focused Transducer

THRU-TRANSMISSION METHOD

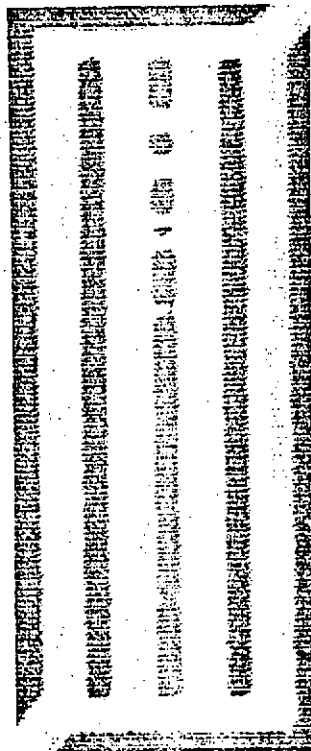
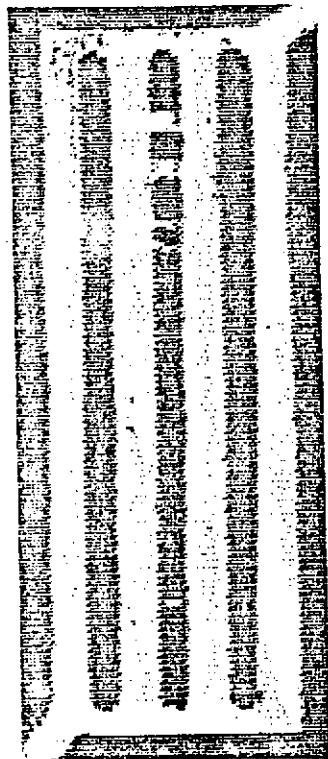
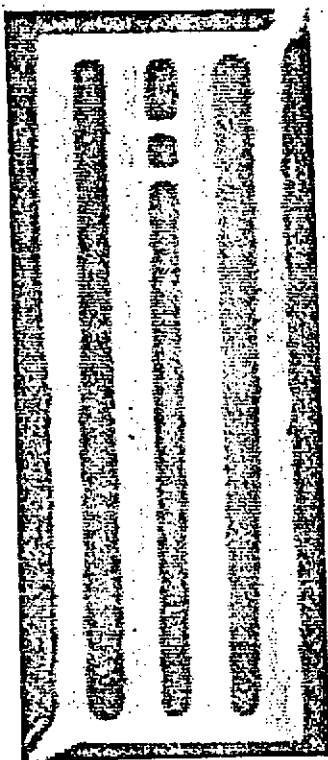
10 N Pulser Receiver

10 MHZ Medium
Focused Transducers

REFLECTOR METHOD

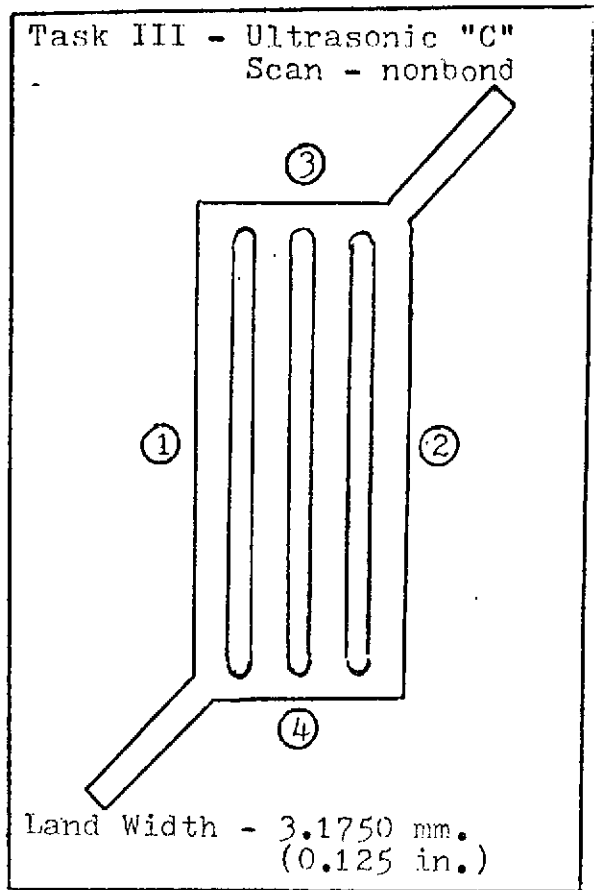
10 N Pulser Receiver

10 MHZ Medium
Focused Transducer



REPRODUCIBILITY OF THE
ORIGINAL PAGE IS POOR

ELECTROFORMED PANEL NO. N-15



BASEPLATE

MATERIAL: Nickel 200

CENTER LAND FLATNESS VARIATION:
0.007 in. (0.1778 mm.)

THICKNESS:	MM.	INCHES
①	6.2789	0.2472
②	6.2789	0.2472
③	6.2611	0.2465
④	6.2611	0.2465

COVERPLATE

MATERIAL: Electroformed Nickel

THICKNESS:	MM.	INCHES
①	1.0185	0.0401
②	1.0084	0.0397
③	1.0135	0.0399
④	0.9728	0.0383

CENTER LAND DEFECT

METALLOGRAPHIC ANALYSIS: Not Applicable

12.700 mm. (0.50 in.)	Slot 3.1750 mm. (0.125 in.)
	Space 3.2004 mm. (0.126 in.)
12.700 mm. (0.50 in.)	Slot 3.1496 mm. (0.124 in.)
	Slot 1.6256 mm. (0.064 in.)
	Space 1.5748 mm. (0.062 in.)
12.700 mm. (0.50 in.)	Slot 1.6256 mm. (0.064 in.)
	Slot 0.7874 mm. (0.031 in.)
	Space 0.8128 mm. (0.032 in.)
12.700 mm. (0.50 in.)	Slot 0.7874 mm. (0.031 in.)
	Slot 0.1016 mm. (0.004 in.)
	Space 0.1524 mm. (0.006 in.)
12.700 mm. (0.50 in.)	Slot 0.1016 mm. (0.004 in.)
	Slot 0.2286 mm. (0.009 in.)
	Space 0.3302 mm. (0.013 in.)
12.700 mm. (0.50 in.)	Slot 0.2032 mm. (0.008 in.)
	Slot 0.4064 mm. (0.016 in.)
	Space 0.3810 mm. (0.015 in.)
12.700 mm. (0.50 in.)	Slot 0.4064 mm. (0.016 in.)

All slots were produced by electric discharge machining to a depth of 0.254 mm. (0.010 in.)

FIGURE B-2

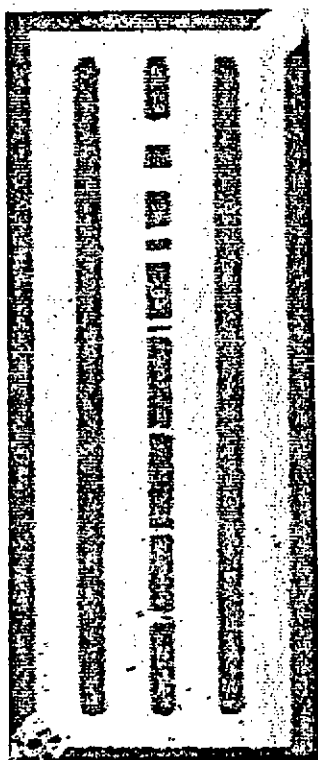
ULTRASONIC "C" SCAN STANDARD

PANEL N-15, COVERPLATE THICKNESS 1.0160 mm. (0.040 in.)

PULSE ECHO METHOD

50 W Pulser Re-
ceiver

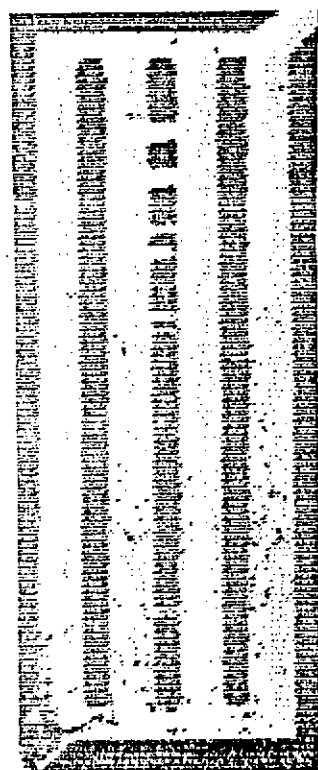
20 MHZ Medium
Focused Transducer



PULSE ECHO METHOD

HRL Pulser Receiver

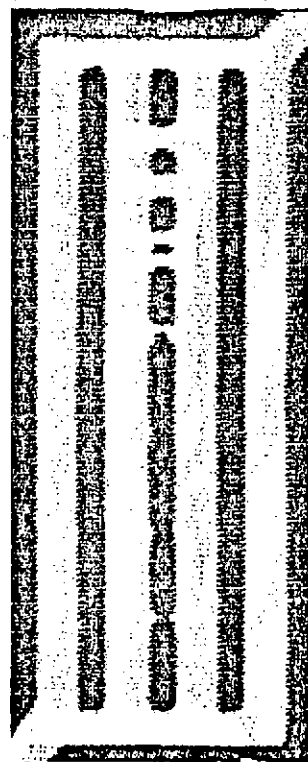
20 MHZ Medium
Focused Transducer



THRU-TRANSMISSION METHOD

10 N Pulser Receiver

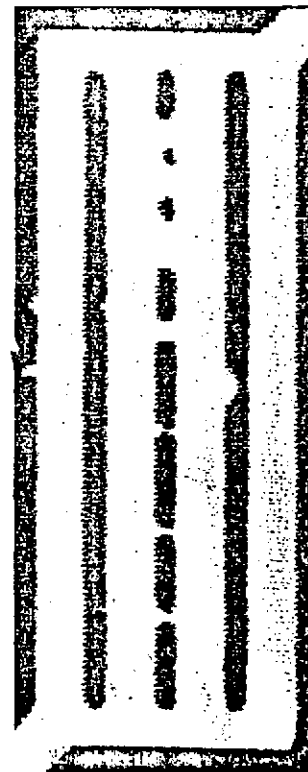
10 MHZ Medium
Focused Transducers



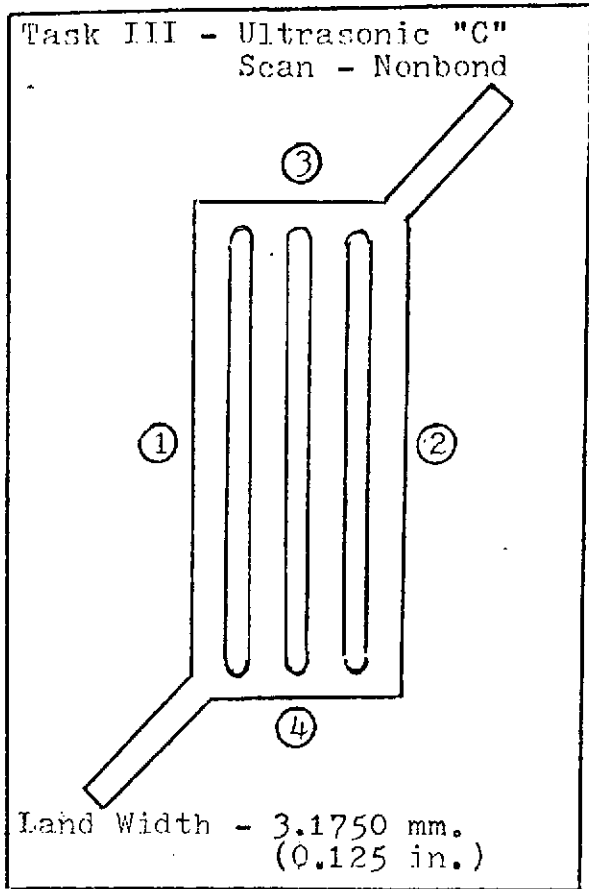
REFLECTOR METHOD

10 N Pulser Receiver

10 MHZ Medium
Focused Transducer



ELECTROFORMED PANEL NO. N-16



BASEPLATE

MATERIAL: Nickel 200

CENTER LAND FLATNESS VARIATION:
0.004 in. (0.1016 mm.)

THICKNESS:	MM.	INCHES
①	6.2890	0.2476
②	6.2611	0.2465
③	6.2484	0.2460
④	6.2560	0.2463

COVERPLATE

MATERIAL: Electroformed Nickel

THICKNESS:	MM.	INCHES
①	1.4529	0.0572
②	1.4884	0.0586
③	1.5469	0.0609
④	1.4910	0.0587

CENTER LAND DEFECT

METALLOGRAPHIC ANALYSIS: Not Applicable

12.700 mm. (0.50 in.)	Slot	3.1496 mm.	(0.124 in.)
	Space	3.2004 mm.	(0.126 in.)
12.700 mm. (0.50 in.)	Slot	3.1750 mm.	(0.125 in.)
	Slot	1.6256 mm.	(0.064 in.)
	Space	1.6256 mm.	(0.064 in.)
12.700 mm. (0.50 in.)	Slot	1.6256 mm.	(0.064 in.)
	Slot	0.7620 mm.	(0.030 in.)
	Space	0.8636 mm.	(0.034 in.)
12.700 mm. (0.50 in.)	Slot	0.7620 mm.	(0.030 in.)
	Slot	0.1016 mm.	(0.004 in.)
	Space	0.1524 mm.	(0.006 in.)
12.700 mm. (0.50 in.)	Slot	0.1016 mm.	(0.004 in.)
	Slot	0.1778 mm.	(0.007 in.)
	Space	0.1778 mm.	(0.007 in.)
12.700 mm. (0.50 in.)	Slot	0.2032 mm.	(0.008 in.)
	Slot	0.3810 mm.	(0.015 in.)
	Space	0.3302 mm.	(0.013 in.)
12.700 mm. (0.50 in.)	Slot	0.4064 mm.	(0.016 in.)

All slots were produced by electric discharge machining to a depth of 0.254 mm. (0.010 in.)

FIGURE E-3

ULTRASONIC "C" SCAN STANDARD

PANEL N-16, COVERPLATE THICKNESS 1.5240 mm. (0.060 in.)

PULSED ECHO METHOD

50 W Pulser Re-
ceiver

20 MHZ Medium
Focused Transducer

PULSE ECHO METHOD

HRL Pulser Receiver

20 MHZ Medium
Focused Transducer

THRU-TRANSMISSION METHOD

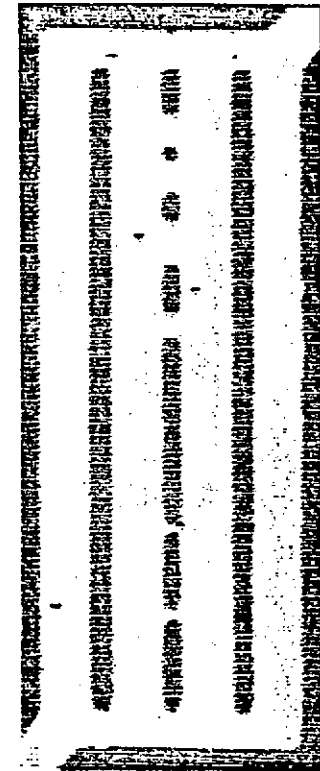
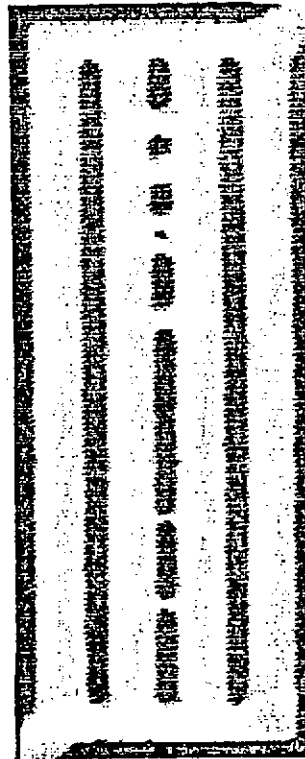
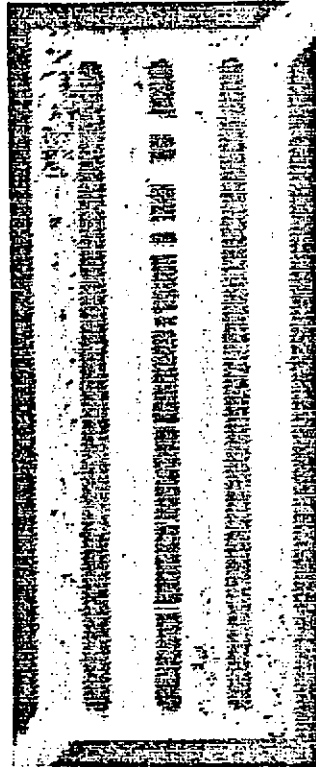
10 N Pulser Receiver

10 MHZ Medium
Focused Transducers

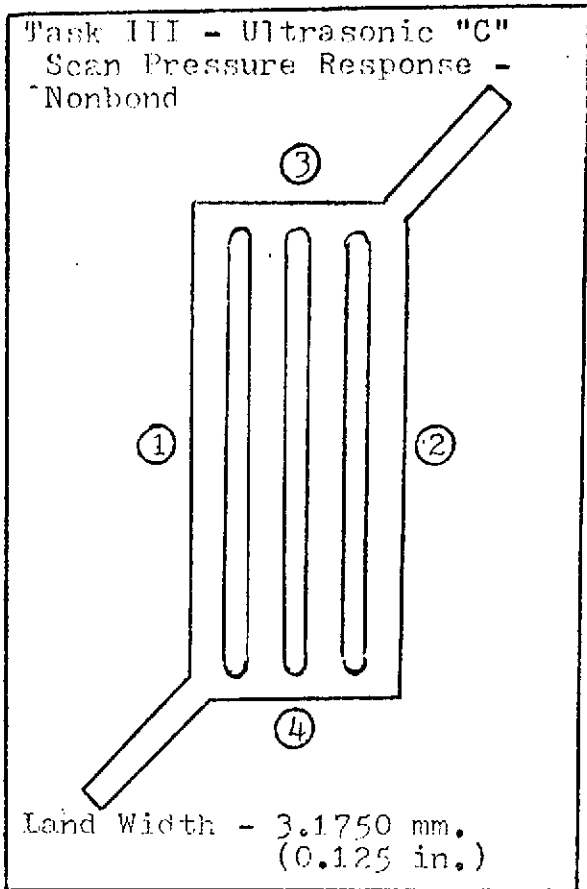
REFLECTOR METHOD

10 N Pulser Receiver

10 MHZ Medium
Focused Transducer



ELECTROFORMED PANEL NO. N-17



BASEPLATE

MATERIAL: Nickel 200

CENTER LAND FLATNESS VARIATION:
0.008 in. (0.2032 mm.)

THICKNESS:	MM.	INCHES
①	6.2499	0.2459
②	6.2357	0.2455
③	6.1900	0.2437
④	6.2230	0.2450

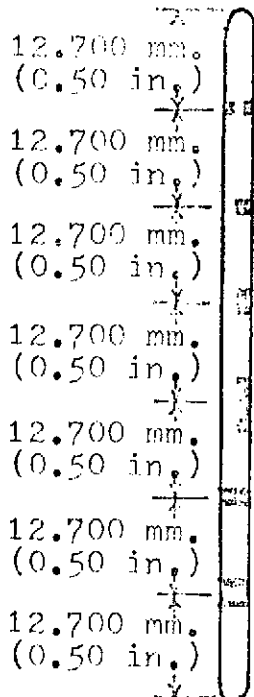
COVERPLATE

MATERIAL: Electroformed Nickel

THICKNESS:	MM.	INCHES
①	0.5512	0.0217
②	0.5232	0.0206
③	0.5791	0.0228
④	0.5385	0.0212

CENTER LAND DEFECT

METALLOGRAPHIC ANALYSIS: Not Applicable



All of the below planned defects are in intimate contact with the electroformed coverplate.
2 areas 1.5748 mm. long x 1.2700 mm. wide
(0.062 in.) (0.050 in.)

Area 1.5748 mm. long x $\frac{1}{2}$ land width
(0.062 in.)

Area 3.1750 mm. long x $\frac{1}{2}$ land width
(0.125 in.)

Area 6.3500 mm. long x $\frac{1}{2}$ land width
(0.250 in.)

Area 1.5748 mm. long x land width
(0.062 in.)

Area 3.1750 mm. long x land width
(0.125 in.)

FIGURE B-4

ULTRASONIC PRESSURE STUDY - PANEL N-17

COVERPLATE THICKNESS 0.5334 mm. (0.021 in.)

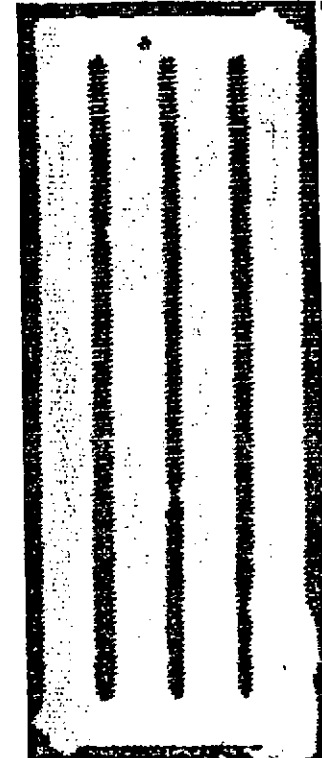
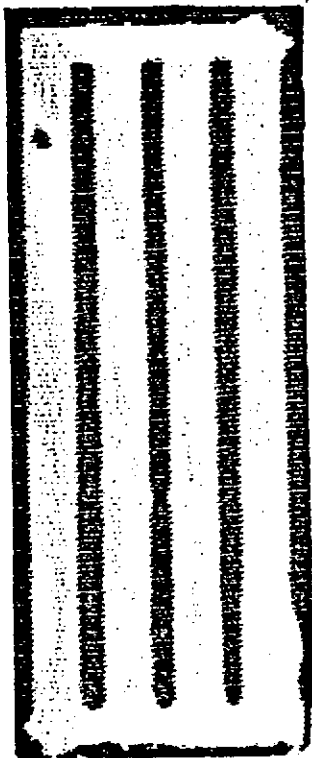
PULSE ECHO METHOD

2.07 MN/m.²
(300 PSI)

3.11 MN/m.²
(450 PSI)

3.11 MN/m.²
(450 PSI)

0 MN/m.²
(0 PSI)

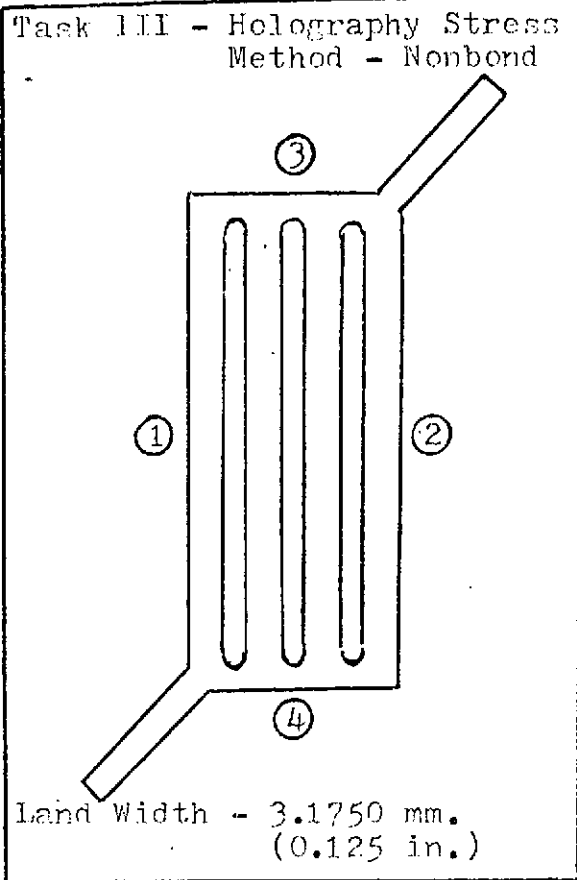


Low Gain

Low Gain

Only the long defect (with respect to land edge) showed response to pressure.

ELECTROFORMED PANEL NO. N-25



BASEPLATE

MATERIAL: Nickel 200

CENTER LAND FLATNESS VARIATION:
0.003 in. (0.0762 mm.)

THICKNESS:	MM.	INCHES
①	6.2509	0.2461
②	6.2509	0.2461
③	6.1976	0.2440
④	6.2509	0.2461

COVERPLATE

MATERIAL: Electroformed Nickel

THICKNESS:	MM.	INCHES
①	1.4249	0.0561
②	1.4732	0.0580
③	1.5189	0.0598
④	1.5418	0.0607

CENTER LAND DEFECT

METALLOGRAPHIC ANALYSIS: Not Applicable

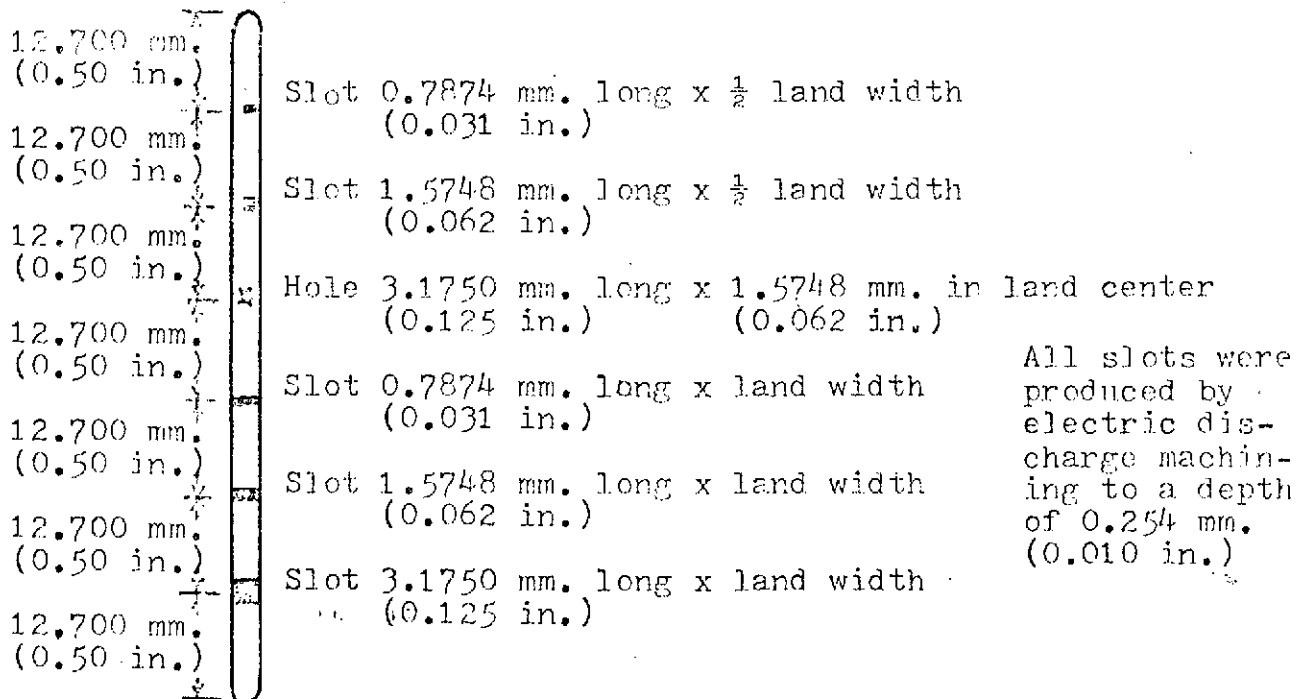
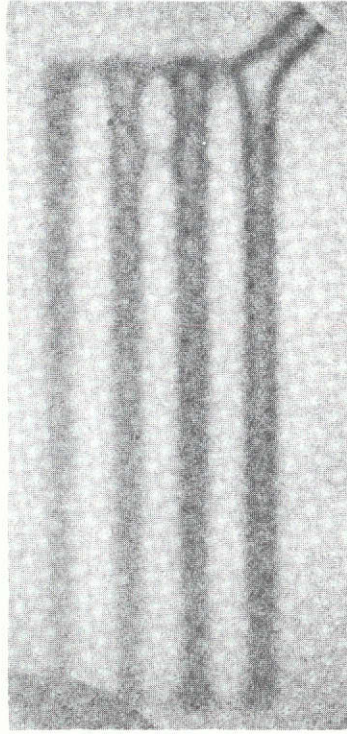
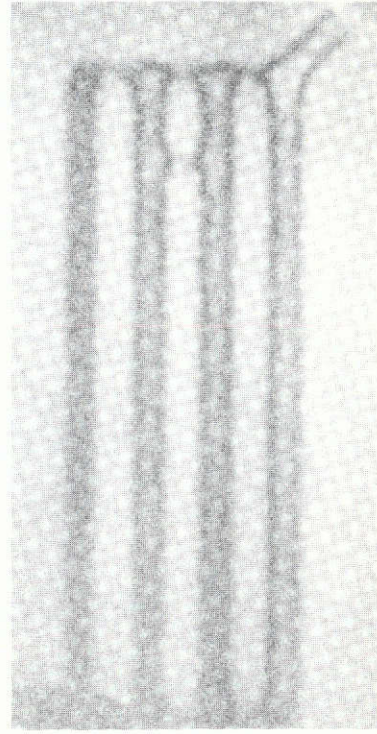


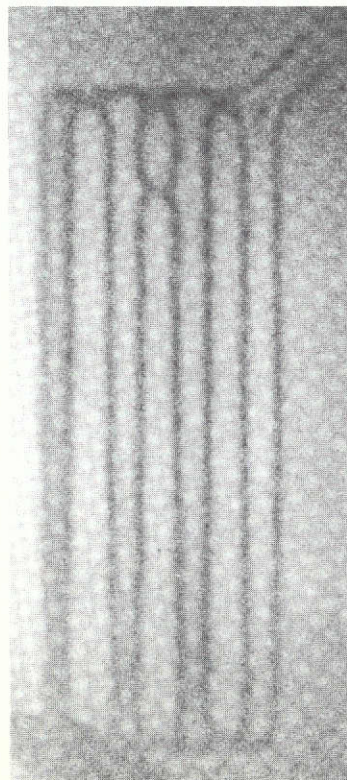
FIGURE B-5



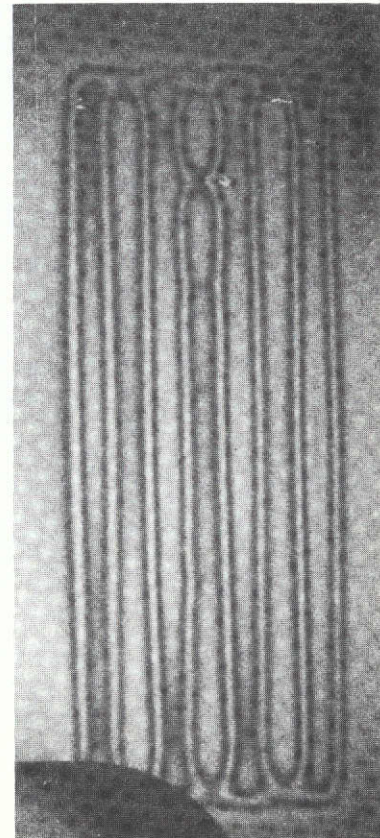
$8.62 \times 10^5 \text{ N/M}^2$
(125 PSI)



$12.07 \times 10^5 \text{ N/M}^2$
(175 PSI)



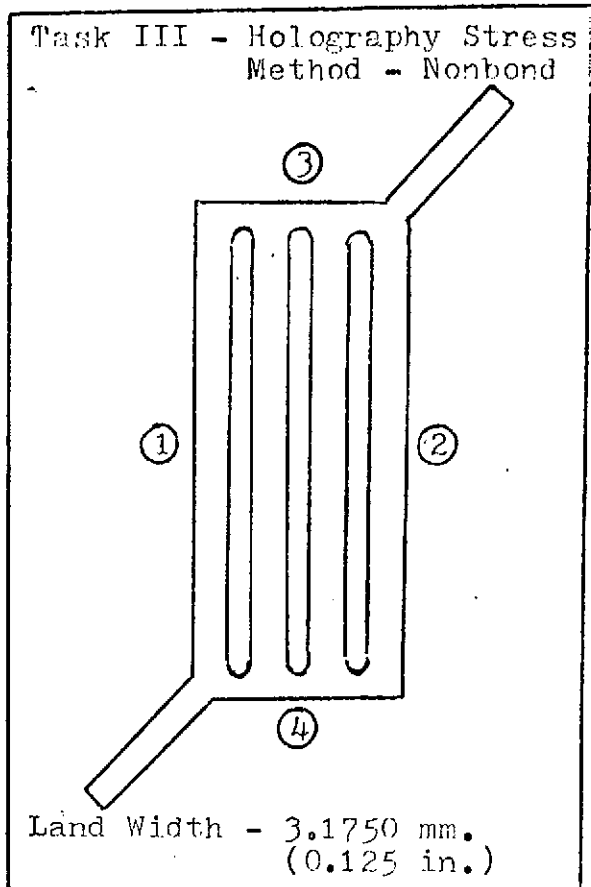
$15.5 \times 10^5 \text{ N/M}^2$
(225 PSI)



$31.0 \times 10^5 \text{ N/M}^2$
(450 PSI)

REPRODUCIBILITY OF THE
ORIGINAL PAGE IS POOR

ELECTROFORMED PANEL NO. N-26



BASEPLATE

MATERIAL: Nickel 200

CENTER LAND FLATNESS VARIATION:
0.003 in. (0.0762 mm.)

THICKNESS:	MM.	INCHES
①	6.1773	0.2432
②	6.1722	0.2430
③	6.1671	0.2428
④	6.1773	0.2432

COVERPLATE

MATERIAL: Electroformed Nickel

THICKNESS:	MM.	INCHES
①	0.5080	0.0200
②	0.5385	0.0212
③	0.5080	0.0200
④	0.5334	0.0210

CENTER LAND DEFECT

METALLOGRAPHIC ANALYSIS: Not Applicable

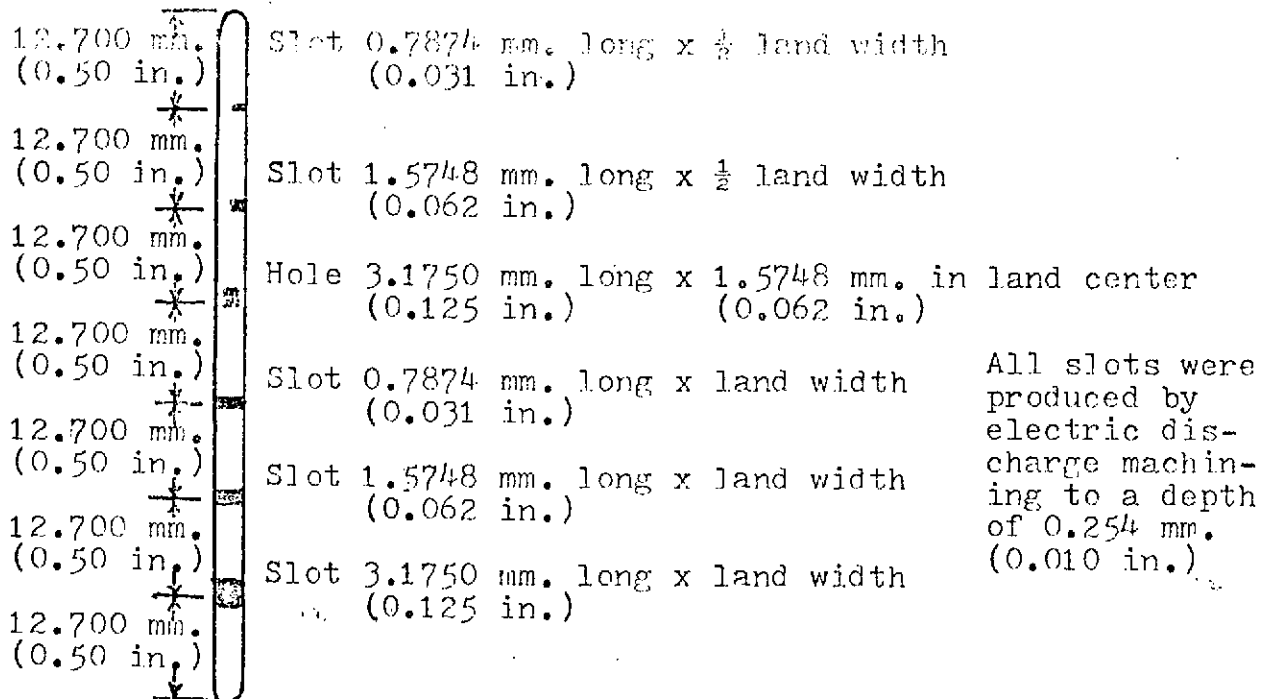
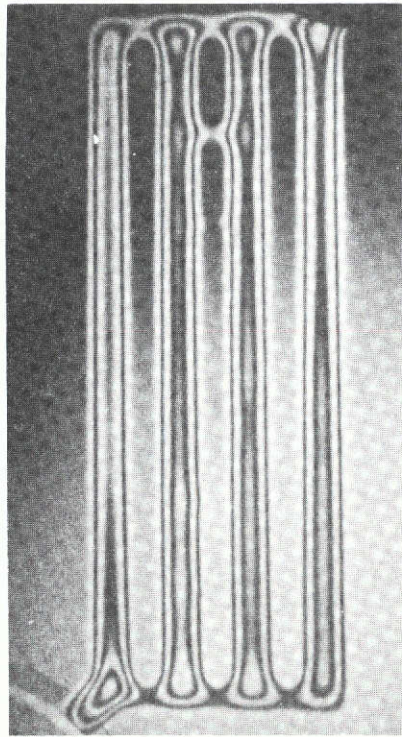
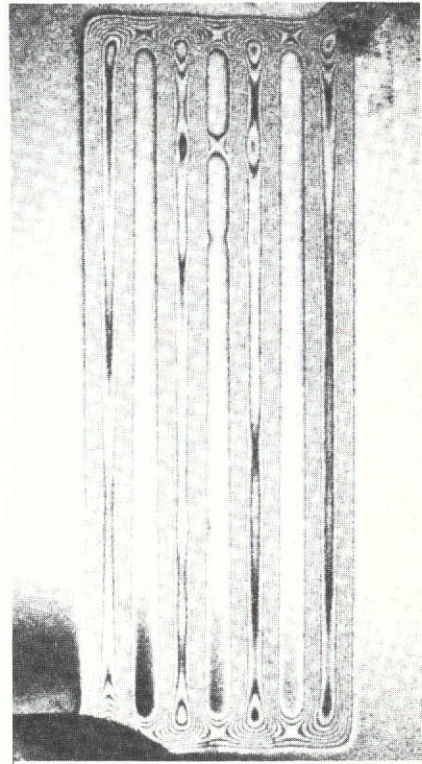


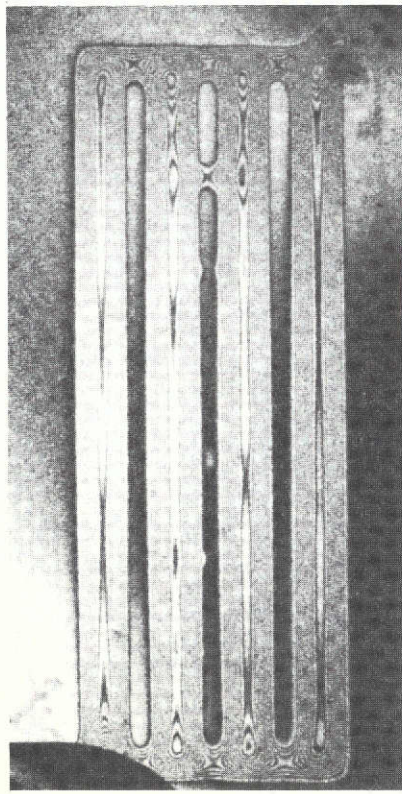
FIGURE B-6



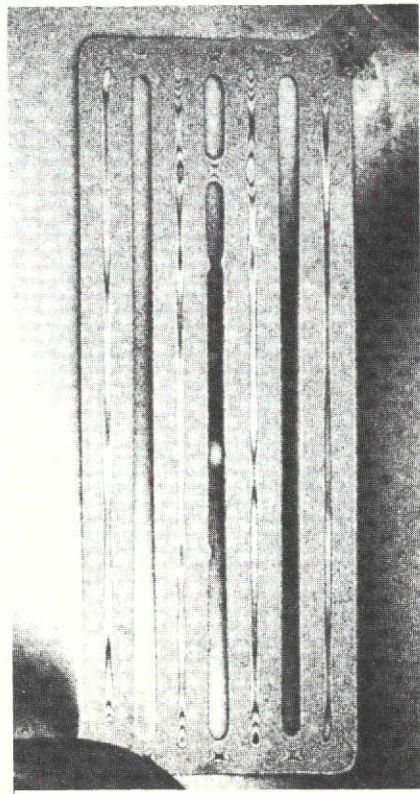
$3.45 \times 10^5 \text{ N/M}^2$
(50 PSI)



$17.25 \times 10^5 \text{ N/M}^2$
(250 PSI)

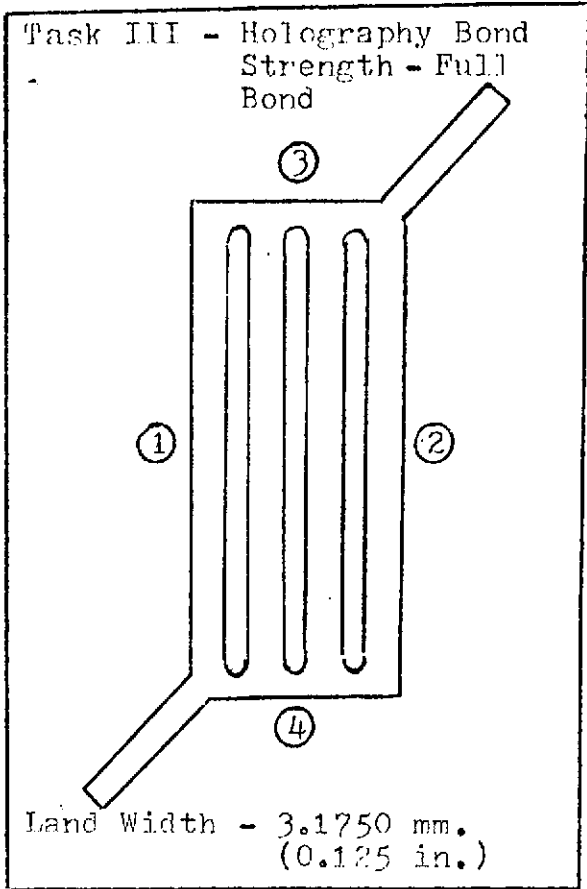


$24.2 \times 10^5 \text{ N/M}^2$
(350 PSI)



$31.0 \times 10^5 \text{ N/M}^2$
(450 PSI)

ELECTROFORMED PANEL NO. N-12



BASEPLATE

MATERIAL: Nickel 200

CENTER LAND FLATNESS VARIATION:
0.001 in. (0.0254 mm.)

THICKNESS:	MM.	INCHES
①	6.2408	0.2457
②	6.2306	0.2453
③	6.2154	0.2447
④	6.2230	0.2450

COVERPLATE

MATERIAL: Electroformed Nickel

THICKNESS:	MM.	INCHES
①	1.4808	0.0583
②	1.4402	0.0567
③	1.4681	0.0578
④	1.4681	0.0578

CENTER LAND DEFECT

METALLOGRAPHIC ANALYSIS: Not Applicable

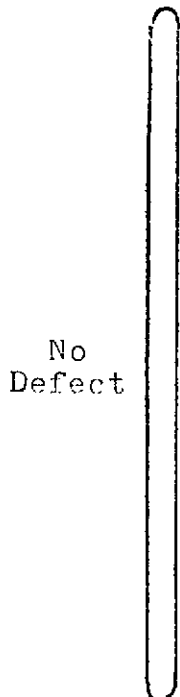
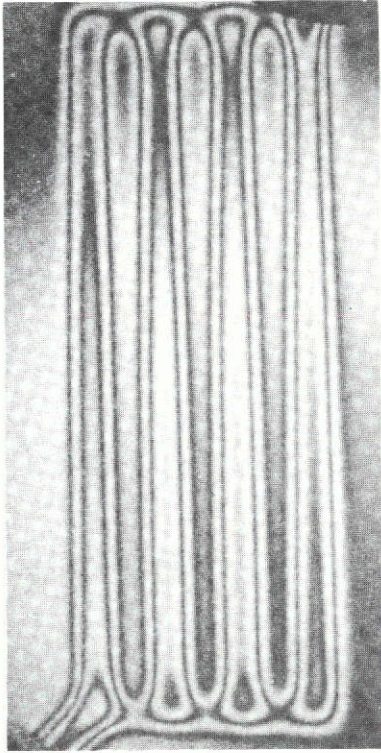


FIGURE B-7

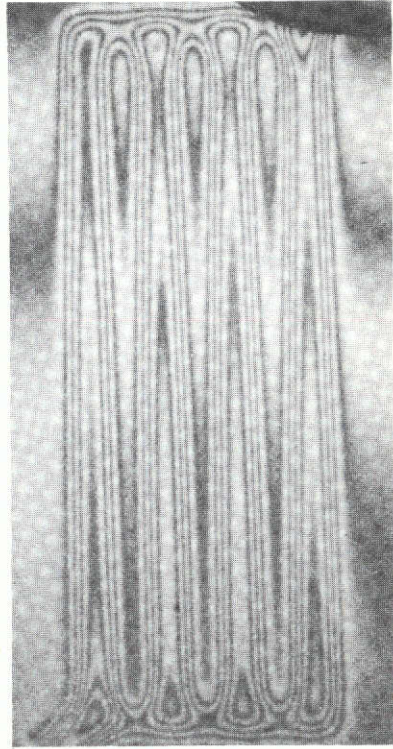
TASK III - HOLOGRAPHY BOND STRENGTH STUDY

N-12 Full



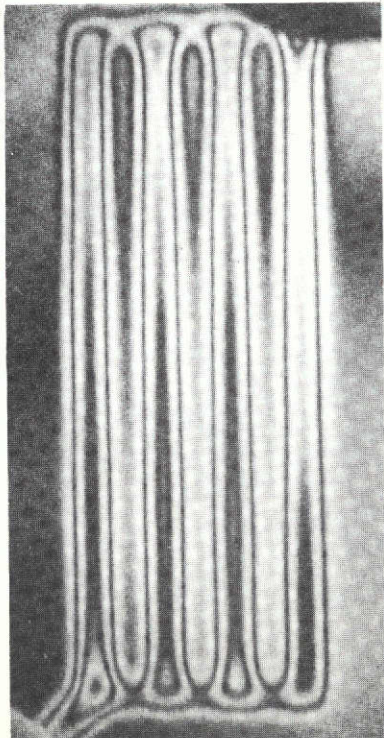
$31.0 \times 10^5 \text{ N/M}^2$
(450 PSI)

N-12 Full



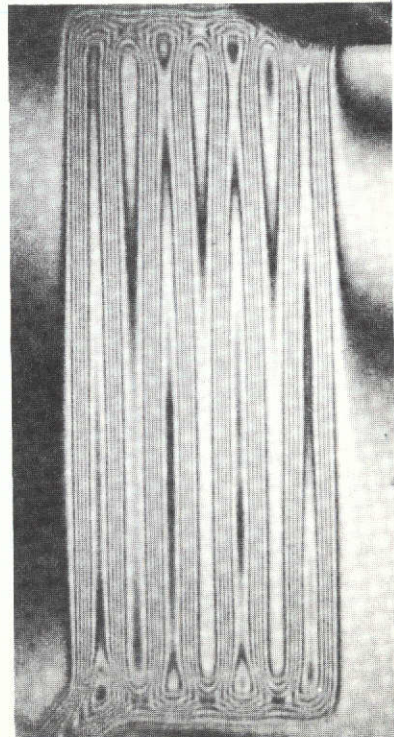
$63.8 \times 10^5 \text{ N/M}^2$
(925 PSI)

N-18 Weak



$37.9 \times 10^5 \text{ N/M}^2$
(550 PSI)

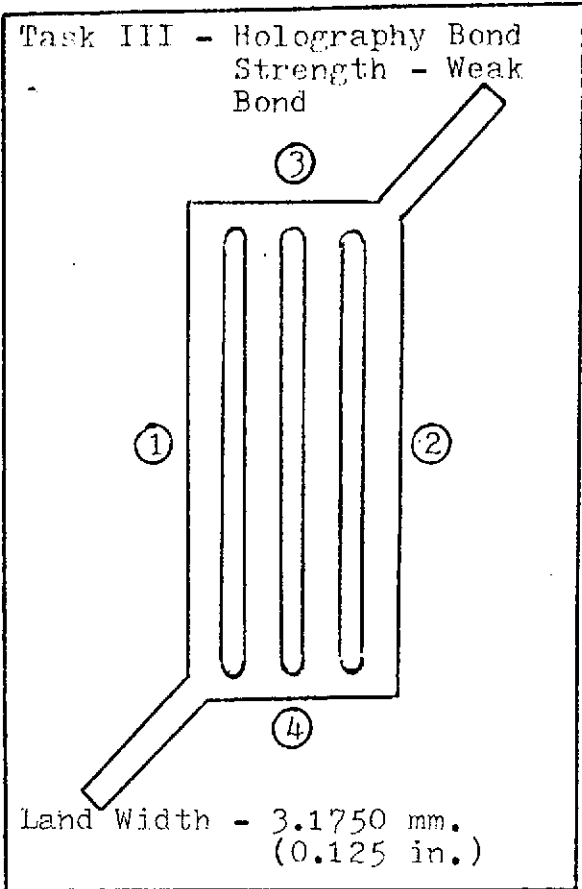
N-18 Weak



$96.6 \times 10^5 \text{ N/M}^2$
(1400 PSI)

REPRODUCIBILITY OF THE
ORIGINAL PAGE IS POOR

ELECTROFORMED PANEL NO. N-18



BASEPLATE

MATERIAL: Nickel 200
CENTER LAND FLATNESS VARIATION:
0.003 in. (0.0762 mm.)

THICKNESS:	MM.	INCHES
①	6.2713	0.2469
②	6.2636	0.2466
③	6.2916	0.2477
④	6.2484	0.2460

COVERPLATE

MATERIAL: Electroformed Nickel

THICKNESS:	MM.	INCHES
①	1.4910	0.0587
②	1.4910	0.0587
③	1.4884	0.0586
④	1.4859	0.0585

CENTER LAND DEFECT

METALLOGRAPHIC ANALYSIS: Not Applicable

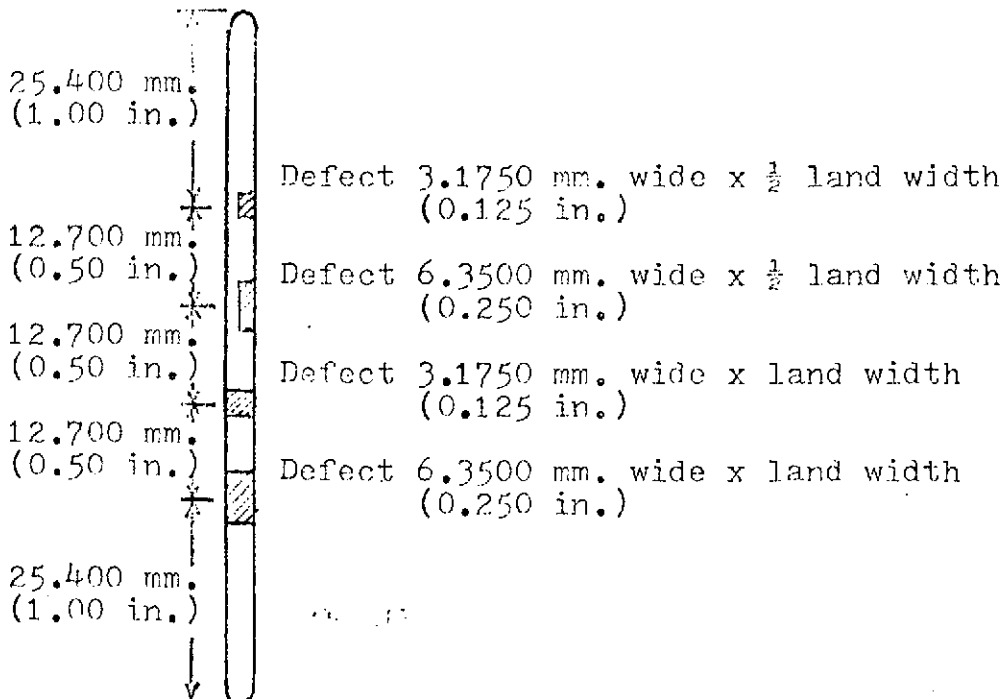
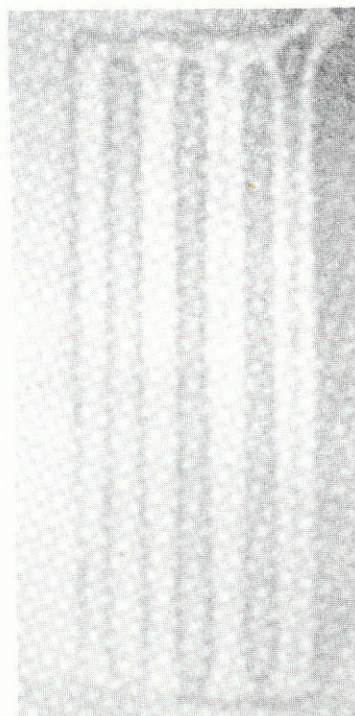


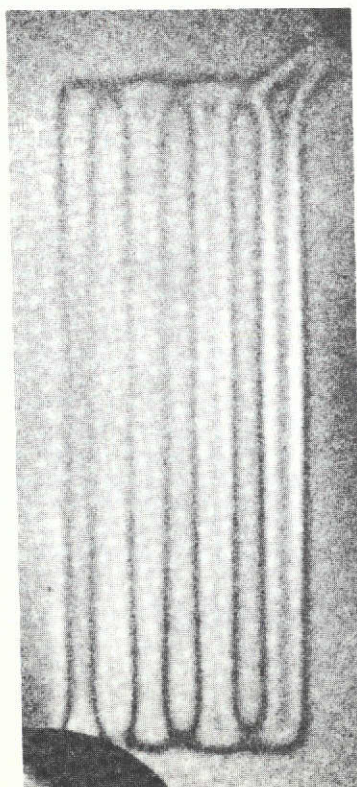
FIGURE B-8



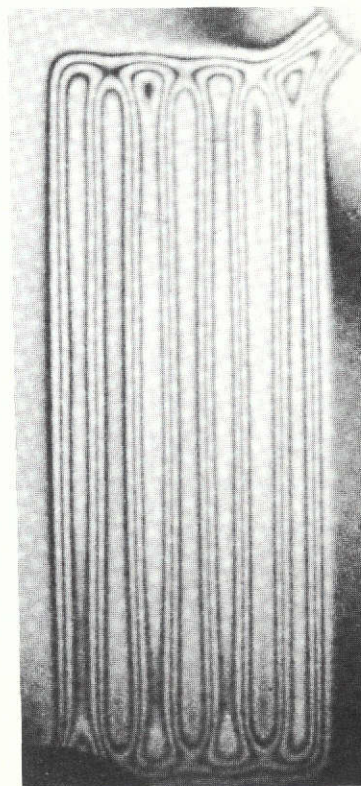
$12.1 \times 10^5 \text{ N/M}^2$
(175 PSI)



$15.5 \times 10^5 \text{ N/M}^2$
(225 PSI)



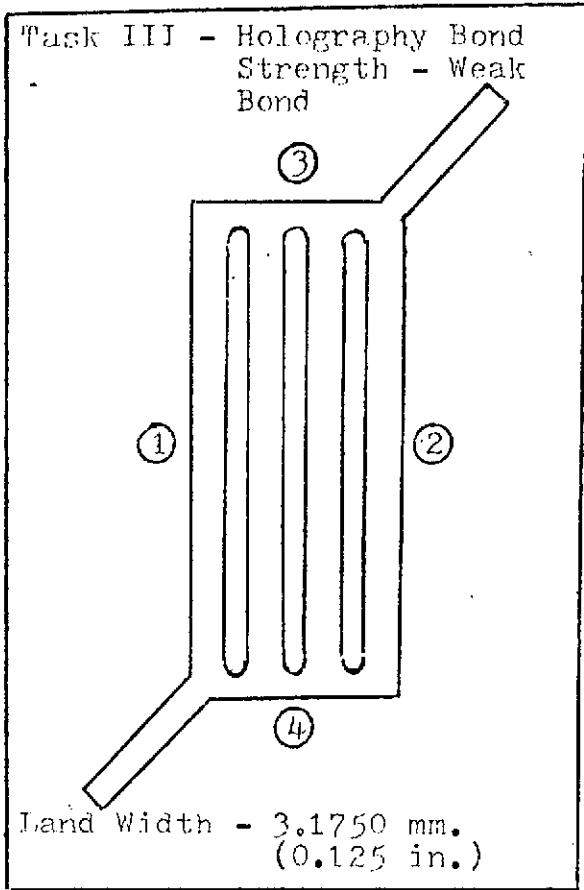
$19.0 \times 10^5 \text{ N/M}^2$
(275 PSI)



$50.0 \times 10^5 \text{ N/M}^2$
(725 PSI)

REPRODUCIBILITY OF THE
ORIGINAL PAGE IS POOR

ELECTROFORMED PANEL NO. N-22



BASEPLATE

MATERIAL: Nickel 200

CENTER LAND FLATNESS VARIATION:
0.003 in. (0.0762 mm.)

THICKNESS:	MM.	INCHES
①	6.1773	0.2432
②	6.1798	0.2433
③	6.1570	0.2424
④	6.1925	0.2438

COVERPLATE

MATERIAL: Electroformed Nickel

THICKNESS:	MM.	INCHES
①	1.3233	0.0521
②	1.3335	0.0525
③	1.4300	0.0563
④	1.3589	0.0535

CENTER LAND DEFECT

METALLOGRAPHIC ANALYSIS: Not Applicable

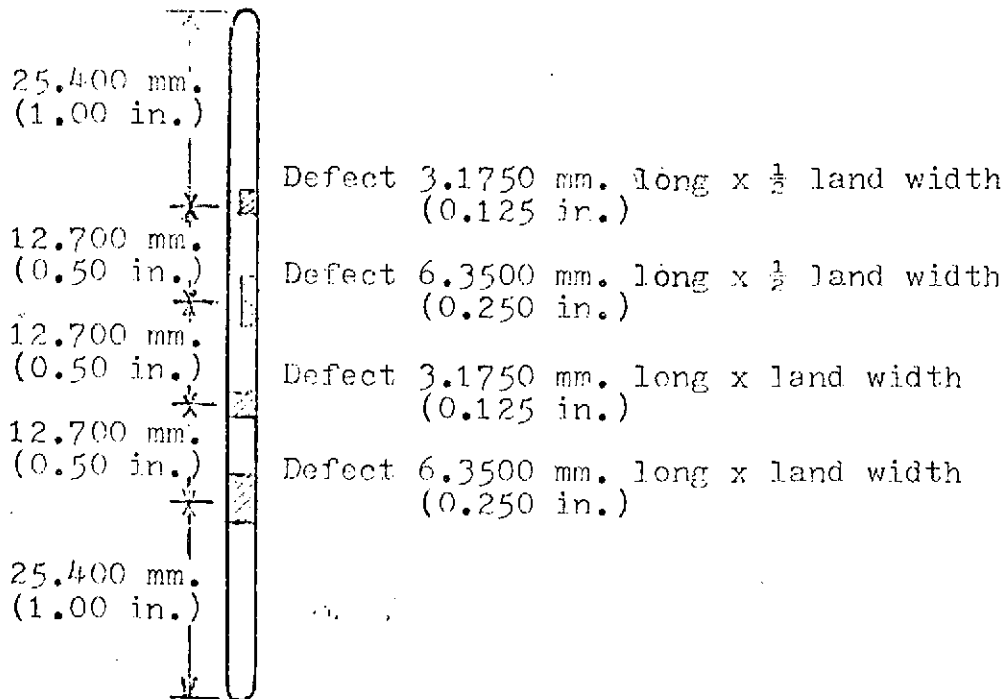
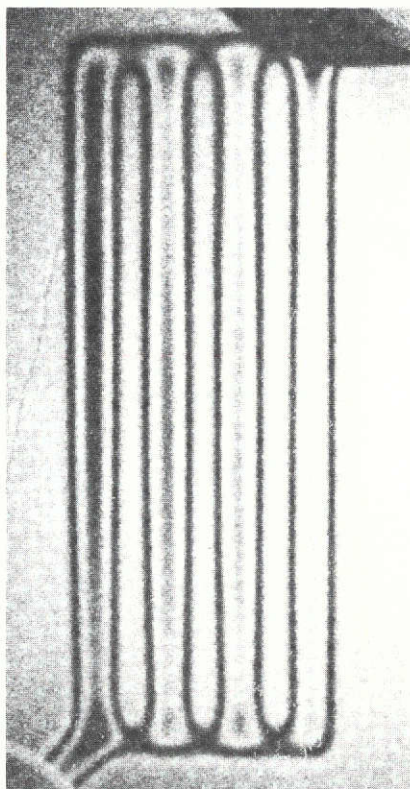
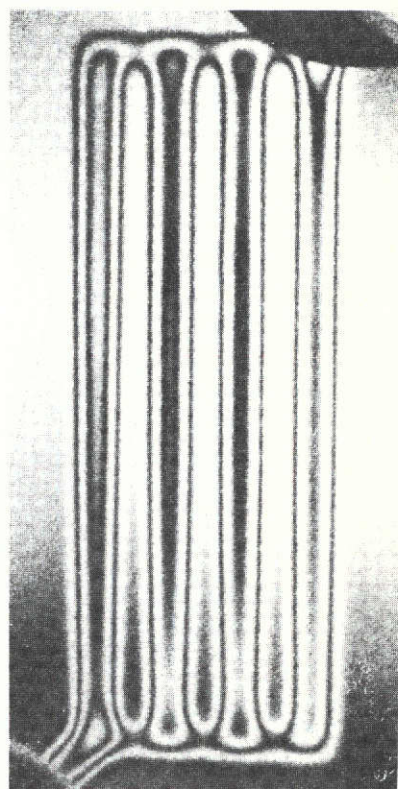


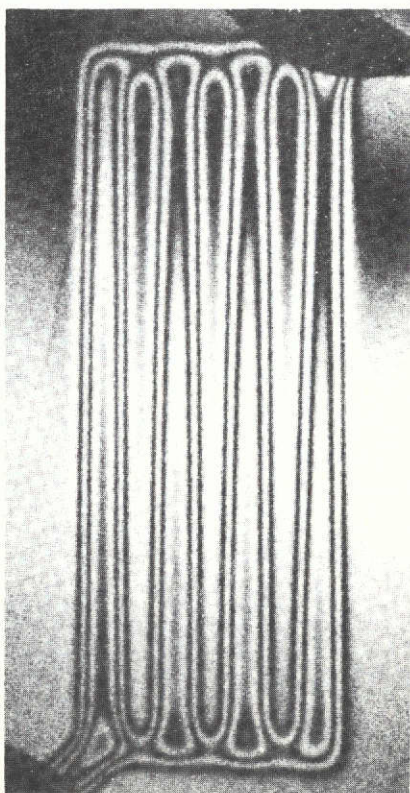
FIGURE B-9



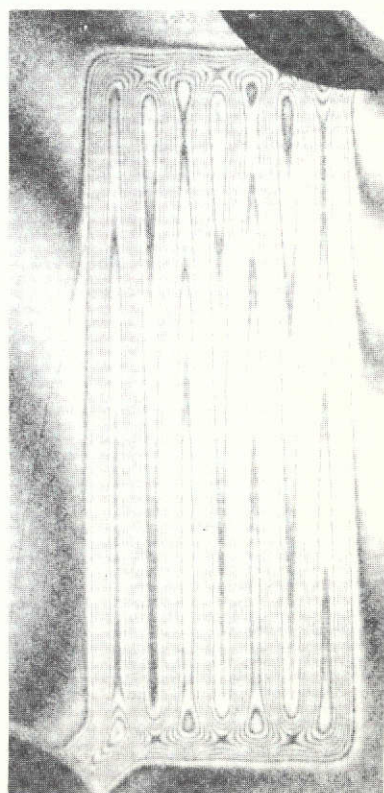
$17.25 \times 10^5 \text{ N/M}^2$
(250 PSI)



$24.2 \times 10^5 \text{ N/M}^2$
(350 PSI)

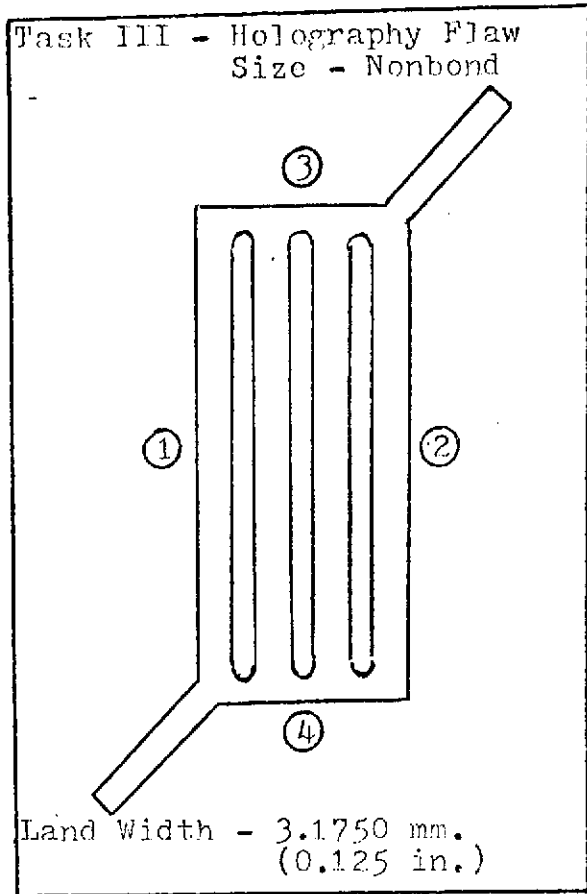


$31.0 \times 10^5 \text{ N/M}^2$
(450 PSI)



$96.6 \times 10^5 \text{ N/M}^2$
(1400 PSI)

ELECTROFORMED PANEL NO. N-23



BASEPLATE

MATERIAL: Nickel 200

CENTER LAND FLATNESS VARIATION:
0.004 in. (0.1016 mm.)

THICKNESS:	MM.	INCHES
①	6.3348	0.2494
②	6.3348	0.2494
③	6.3017	0.2481
④	6.3576	0.2503

COVERPLATE

MATERIAL: Electroformed Nickel

THICKNESS:	MM.	INCHES
①	1.4453	0.0569
②	1.4072	0.0554
③	1.4656	0.0577
④	1.3792	0.0543

CENTER LAND DEFECT.

METALLOGRAPHIC ANALYSIS: Not Applicable

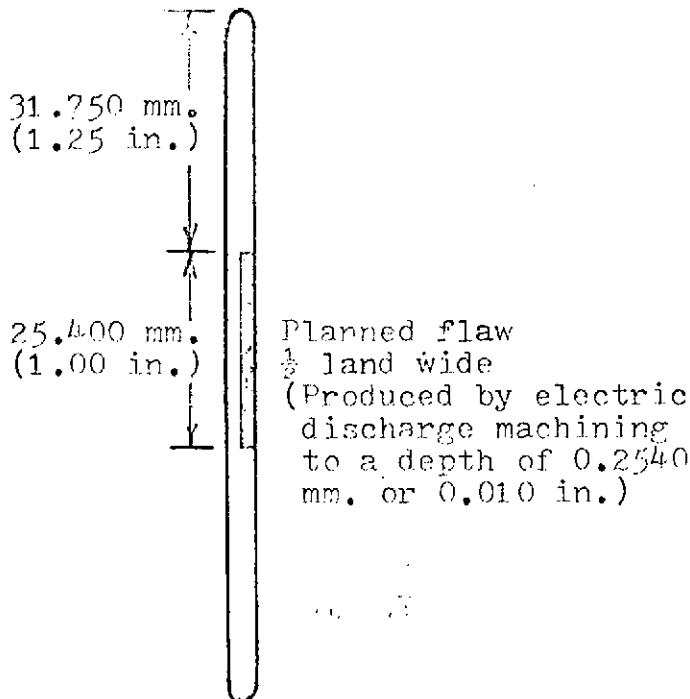
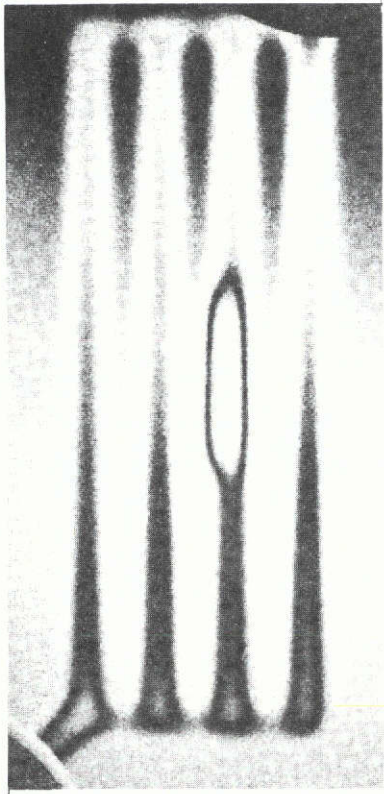
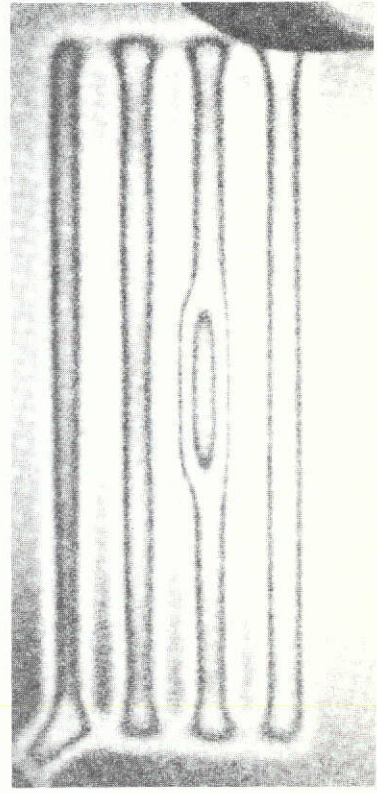


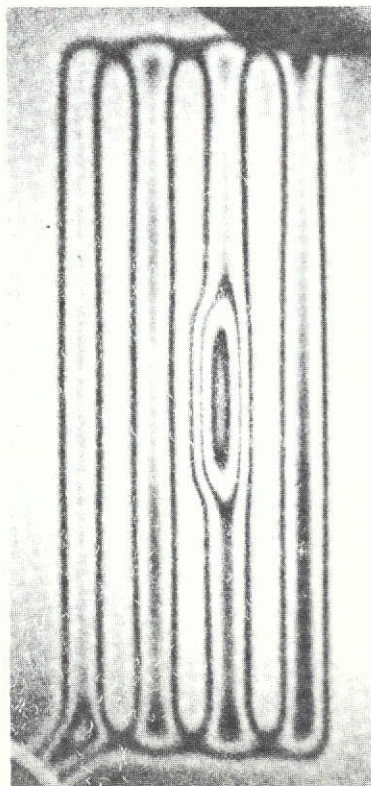
FIGURE B-10



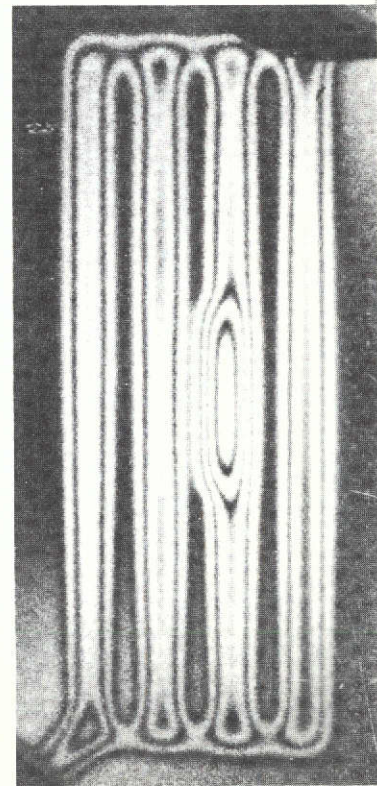
$10.4 \times 10^5 \text{ N/M}^2$
(150 PSI)



$17.25 \times 10^5 \text{ N/M}^2$
(250 PSI)



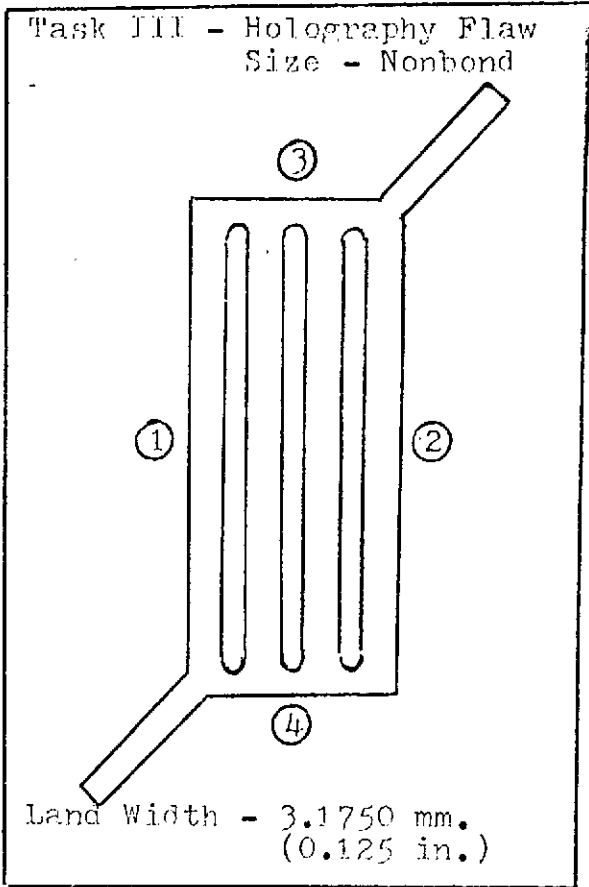
$24.2 \times 10^5 \text{ N/M}^2$
(350 PSI)



$31.0 \times 10^5 \text{ N/M}^2$
(450 PSI)

REPRODUCIBILITY OF THE
ORIGINAL PAGE IS POOR

ELECTROFORMED PANEL NO. N-24



BASEPLATE

MATERIAL: Nickel 200

CENTER LAND FLATNESS VARIATION:
0.001 in. (0.0254 mm.)

THICKNESS:	MM.	INCHES
①	6.2281	0.2452
②	6.2078	0.2444
③	6.2103	0.2445
④	6.1925	0.2438

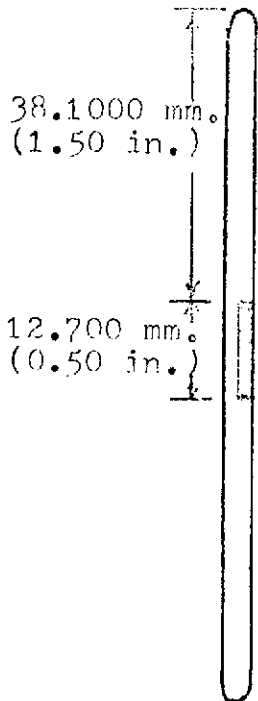
COVERPLATE

MATERIAL: Electroformed Nickel

THICKNESS:	MM.	INCHES
①	1.4021	0.0552
②	1.4173	0.0558
③	1.4351	0.0565
④	1.4351	0.0565

CENTER LAND DEFECT

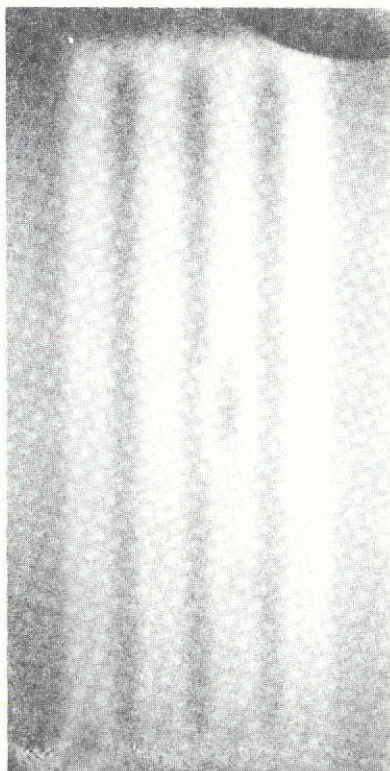
METALLOGRAPHIC ANALYSIS: Not Applicable



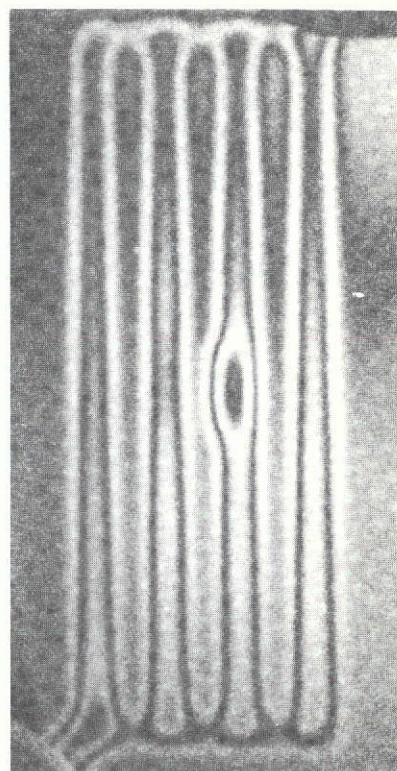
Planned flaw $\frac{1}{2}$ land wide
(produced by electric discharge
machining to a depth of
0.2540 mm. or 0.010 in.)

FIGURE B-11

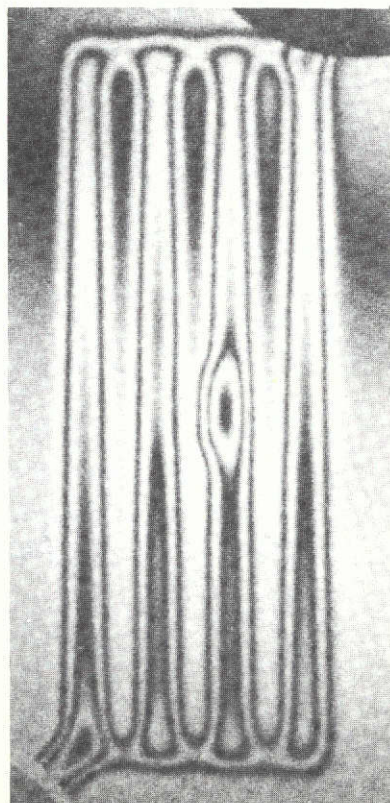
REPRODUCIBILITY OF THE
ORIGINAL PAGE IS POOR



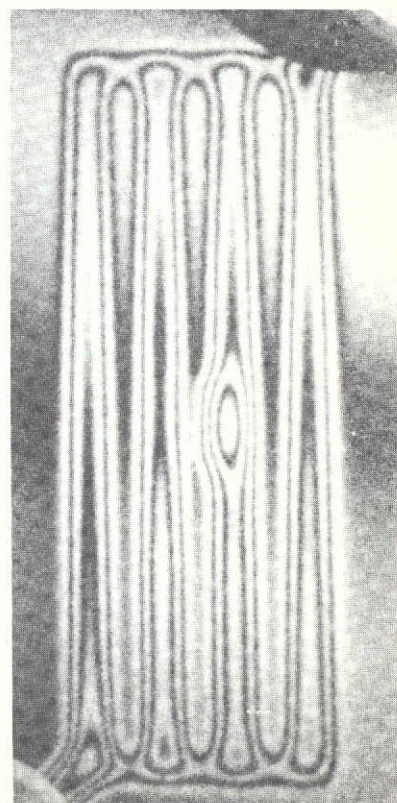
50 PSI



250 PSI

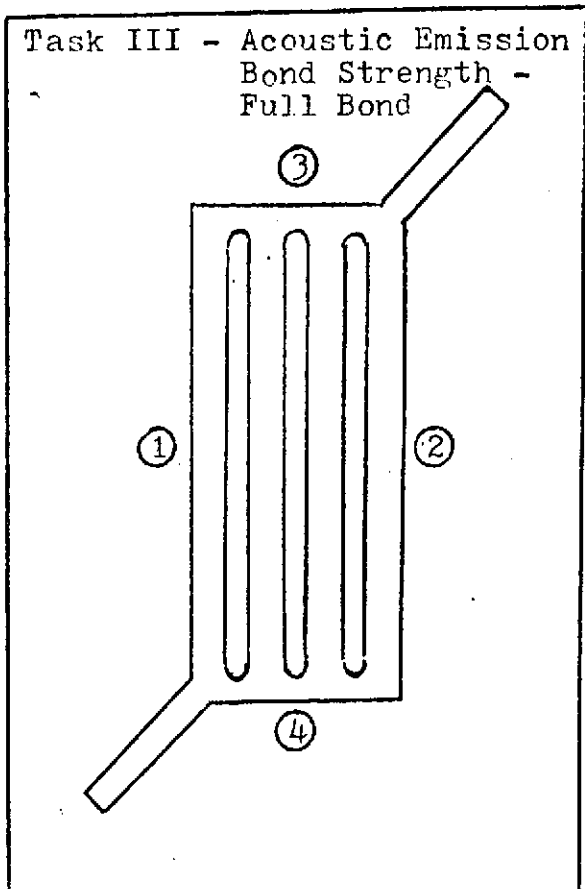


350 PSI



450 PSI

ELECTROFORMED PANEL NO. N-10



BASEPLATE

MATERIAL: Nickel 200
CENTER LAND FLATNESS VARIATION:
0.003 in. (0.0762 mm.)

THICKNESS:	MM.	INCHES
①	6.3449	0.2498
②	6.3475	0.2499
③	6.2586	0.2464
④	6.3271	0.2491

COVERPLATE

MATERIAL: Electroformed Nickel

THICKNESS:	MM.	INCHES
①	1.4656	0.0577
②	1.4961	0.0589
③	1.5265	0.0601
④	1.4783	0.0582

CENTER LAND DEFECT

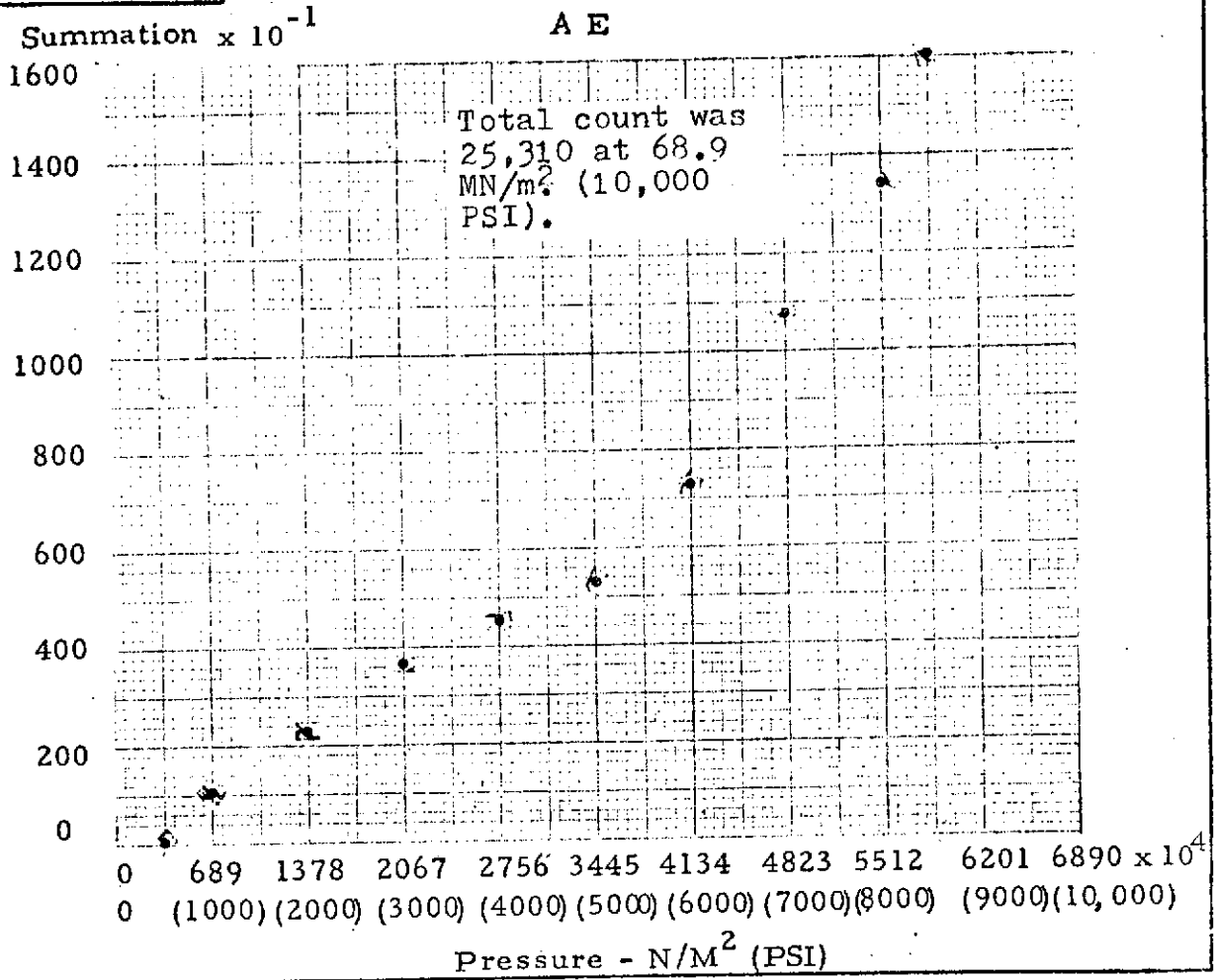
METALLOGRAPHIC ANALYSIS: Not Applicable

No
Defect

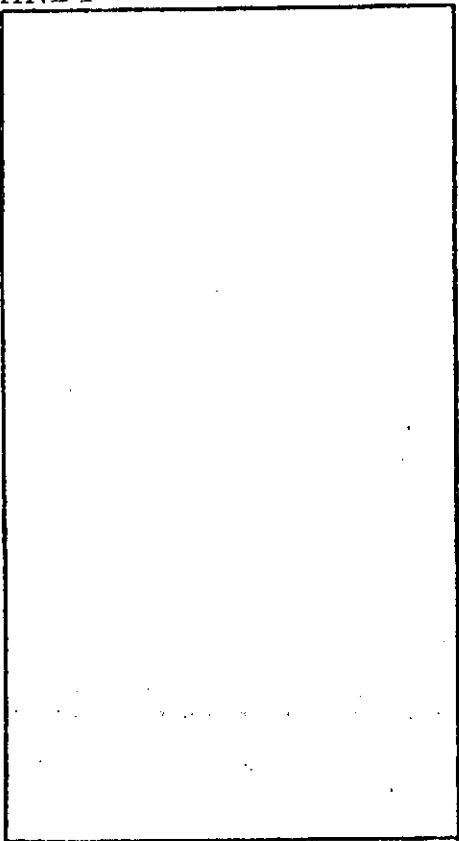


FIGURE B-12

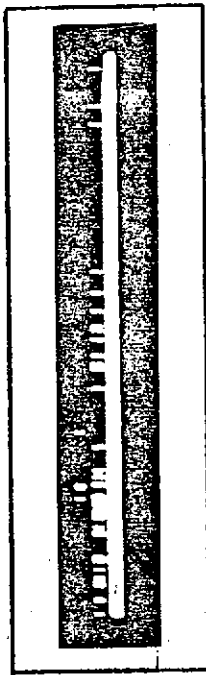
Panel No. N-10



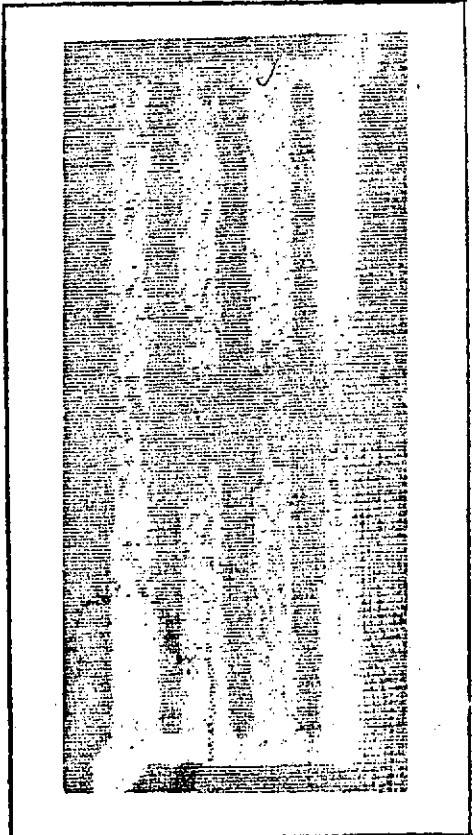
HNDT



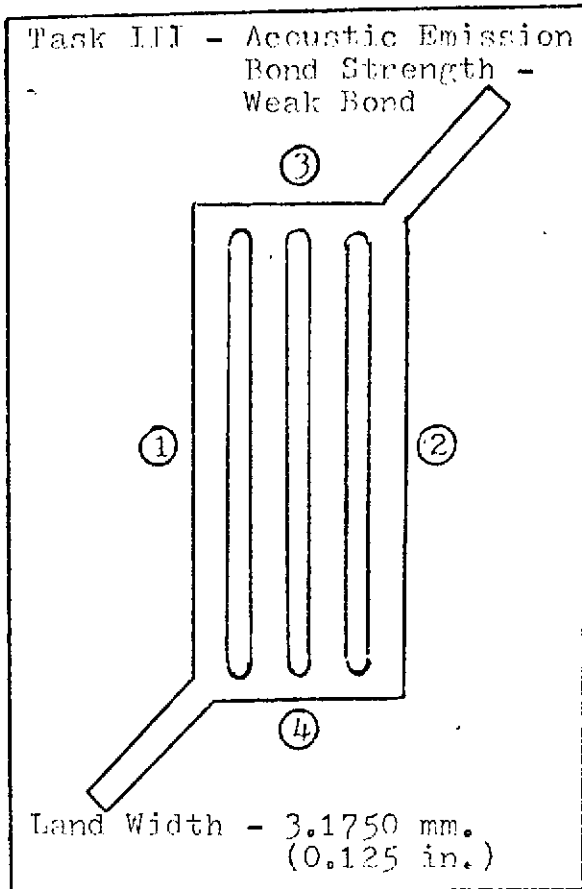
AE
FLAW LOCATOR
CENTER LAND



UT



ELECTROFORMED PANEL NO. N-44



BASEPLATE

MATERIAL: Nickel 200

CENTER LAND FLATNESS VARIATION:
0.0005 in. (0.0127 mm.)

THICKNESS:	MM.	INCHES
①	6.3144	0.2486
②	6.3170	0.2487
③	6.3297	0.2492
④	6.3246	0.2490

COVERPLATE

MATERIAL: Electroformed Nickel

THICKNESS:	MM.	INCHES
①	1.4859	0.0585
②	1.4707	0.0579
③	1.4681	0.0578
④	1.4681	0.0578

CENTER LAND DEFECT

METALLOGRAPHIC ANALYSIS: Not Applicable

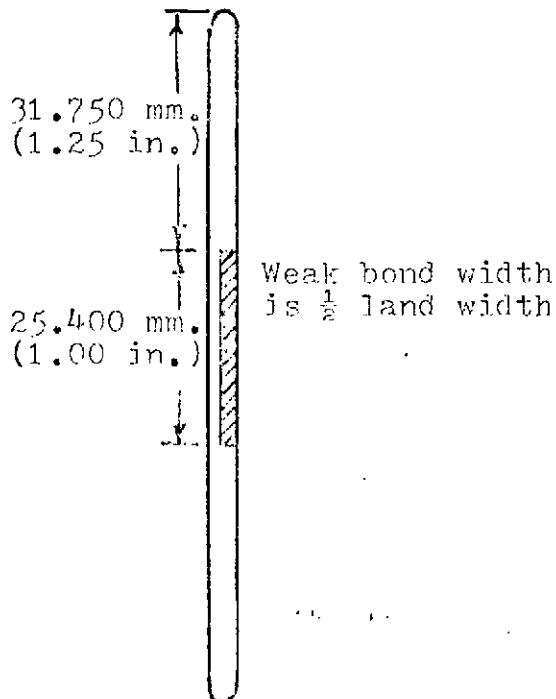
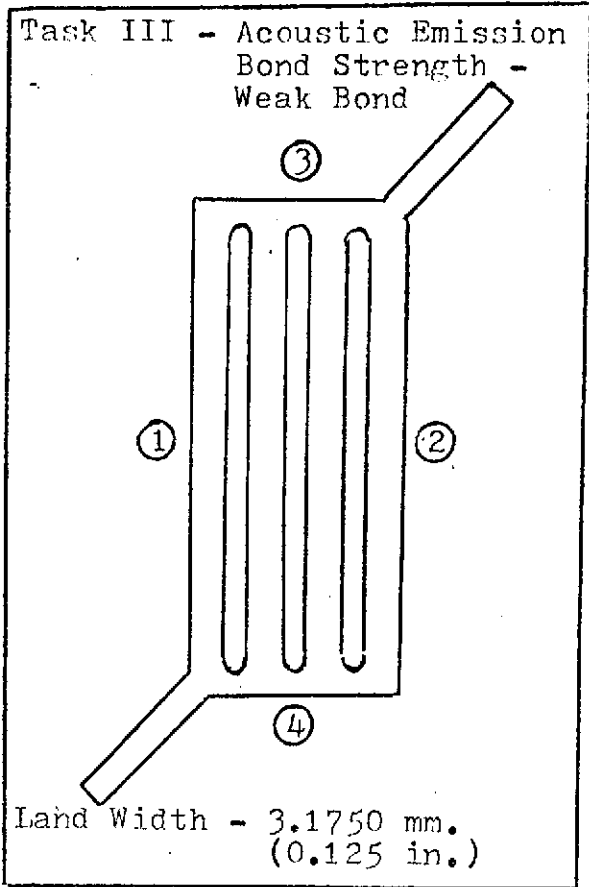


FIGURE B-13

ELECTROFORMED PANEL NO. N-45



BASEPLATE

MATERIAL: Nickel 200

CENTER LAND FLATNESS VARIATION:
0.0015 in. (0.0381 mm.)

THICKNESS:	MM.	INCHES
①	6.2738	0.2470
②	6.2763	0.2471
③	6.2636	0.2466
④	6.2763	0.2471

COVERPLATE

MATERIAL: Electroformed Nickel

THICKNESS:	MM.	INCHES
①	0.8509	0.0335
②	0.8484	0.0334
③	0.8204	0.0323
④	0.8712	0.0343

CENTER LAND DEFECT

METALLOGRAPHIC ANALYSIS: Not Applicable

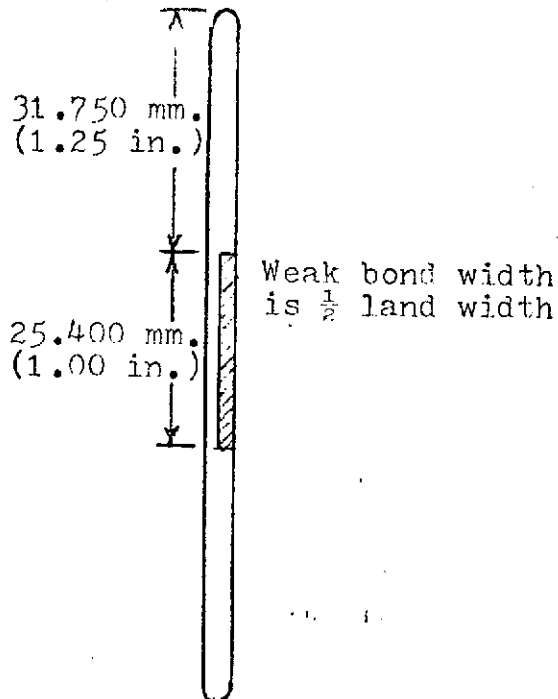
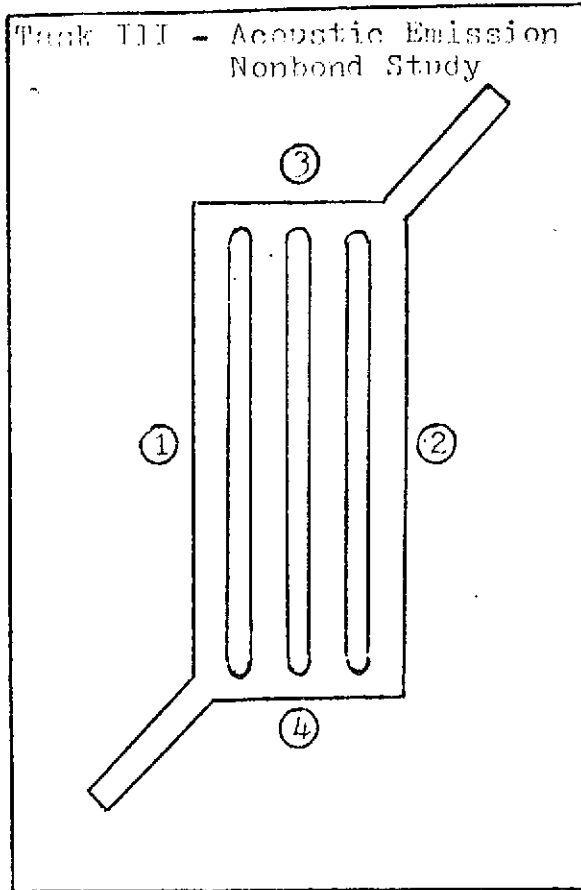


FIGURE B-14

ELECTROFORMED PANEL NO. N-27



BASEPLATE

MATERIAL: Nickel 200

CENTER LAND FLATNESS VARIATION:
0.002 in. (0.0508 mm.)

THICKNESS:	MM.	INCHES
①	6.3551	0.2502
②	6.3475	0.2499
③	6.3094	0.2484
④	6.3525	0.2501

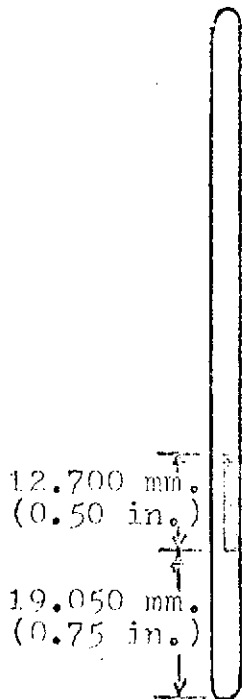
COVERPLATE

MATERIAL: Electroformed Nickel

THICKNESS:	MM.	INCHES
①	1.3462	0.0530
②	1.2954	0.0510
③	1.3386	0.0527
④	1.3411	0.0528

CENTER LAND DEFECT

METALLOGRAPHIC ANALYSIS: Not Applicable



Planned flaw $\frac{1}{8}$ land wide
(produced by electric discharge
machining to a depth of
0.2540 mm. or 0.010 in.)

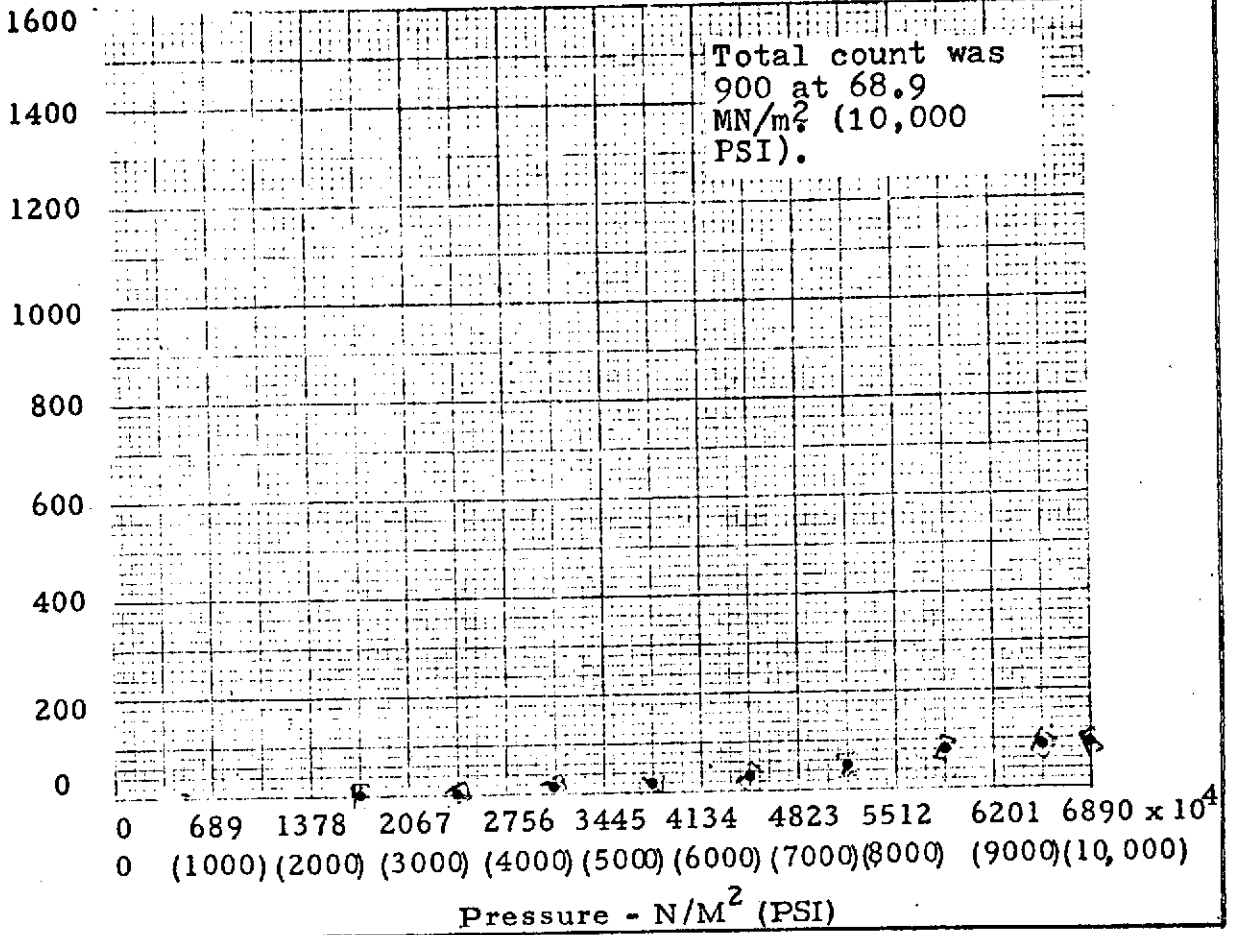
**REPRODUCIBILITY OF THE
ORIGINAL PAGE IS POOR**

FIGURE B-1.5

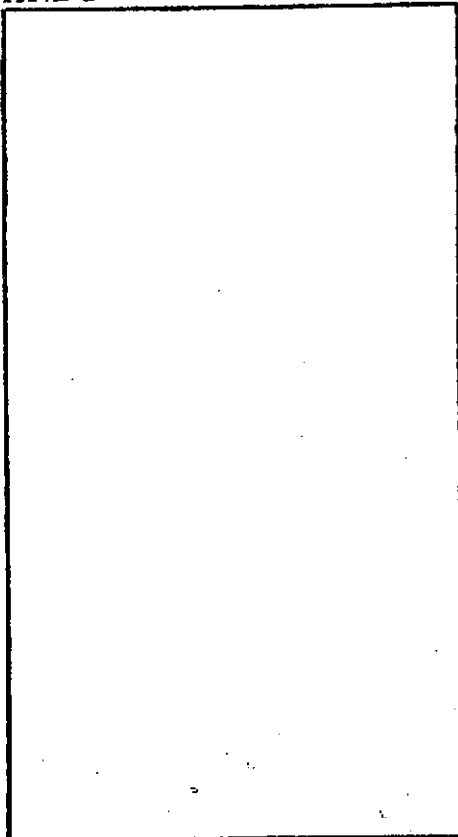
Panel No. N-27

Summation $\times 10^{-1}$

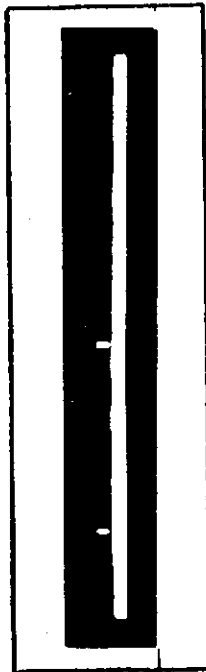
A E



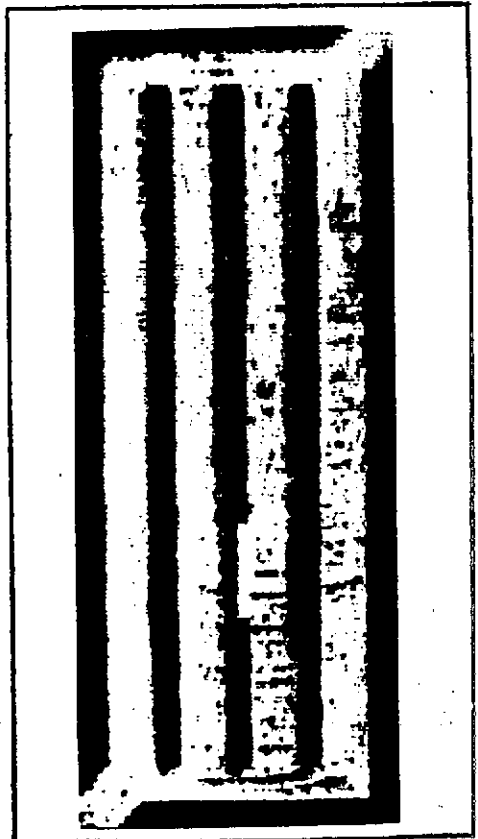
HNDT



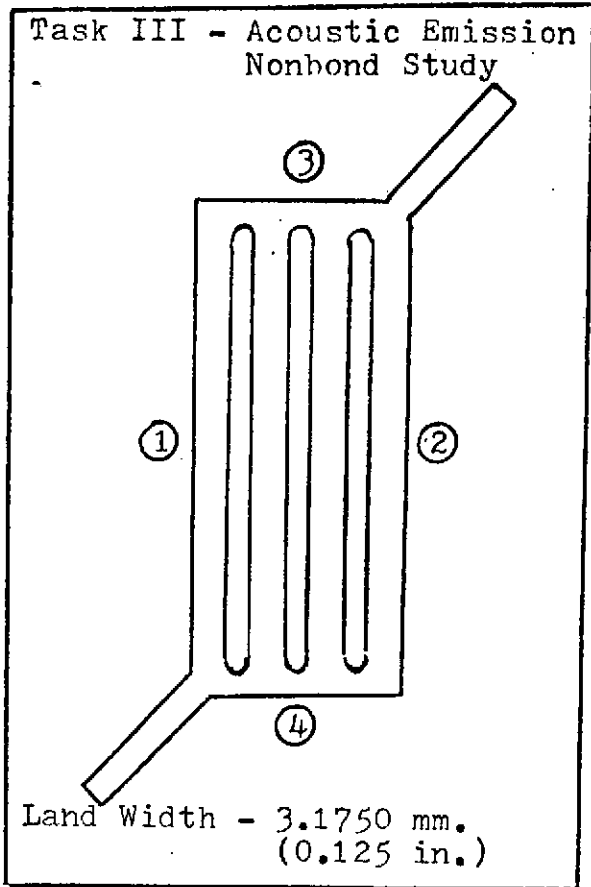
AE
FLAW LOCATOR
CENTER LAND



UT



ELECTROFORMED PANEL NO. N-28 "A"



BASEPLATE

MATERIAL: Nickel 200
CENTER LAND FLATNESS VARIATION:
0.001 in. (0.0254 mm.)

THICKNESS:	MM.	INCHES
①	6.0503	0.2382
②	6.0579	0.2385
③	6.1163	0.2408
④	6.1239	0.2411

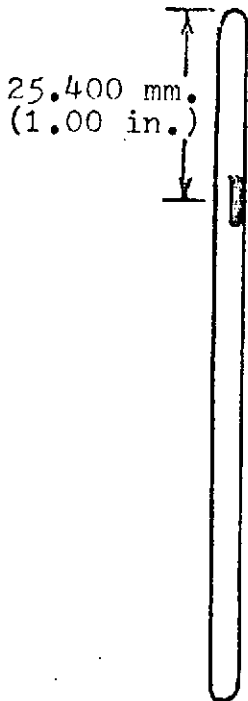
COVERPLATE

MATERIAL: Electroformed Nickel

THICKNESS:	MM.	INCHES
①	1.0643	0.0419
②	1.0719	0.0422
③	0.9881	0.0389
④	1.0084	0.0397

CENTER LAND DEFECT

METALLOGRAPHIC ANALYSIS: Not Applicable



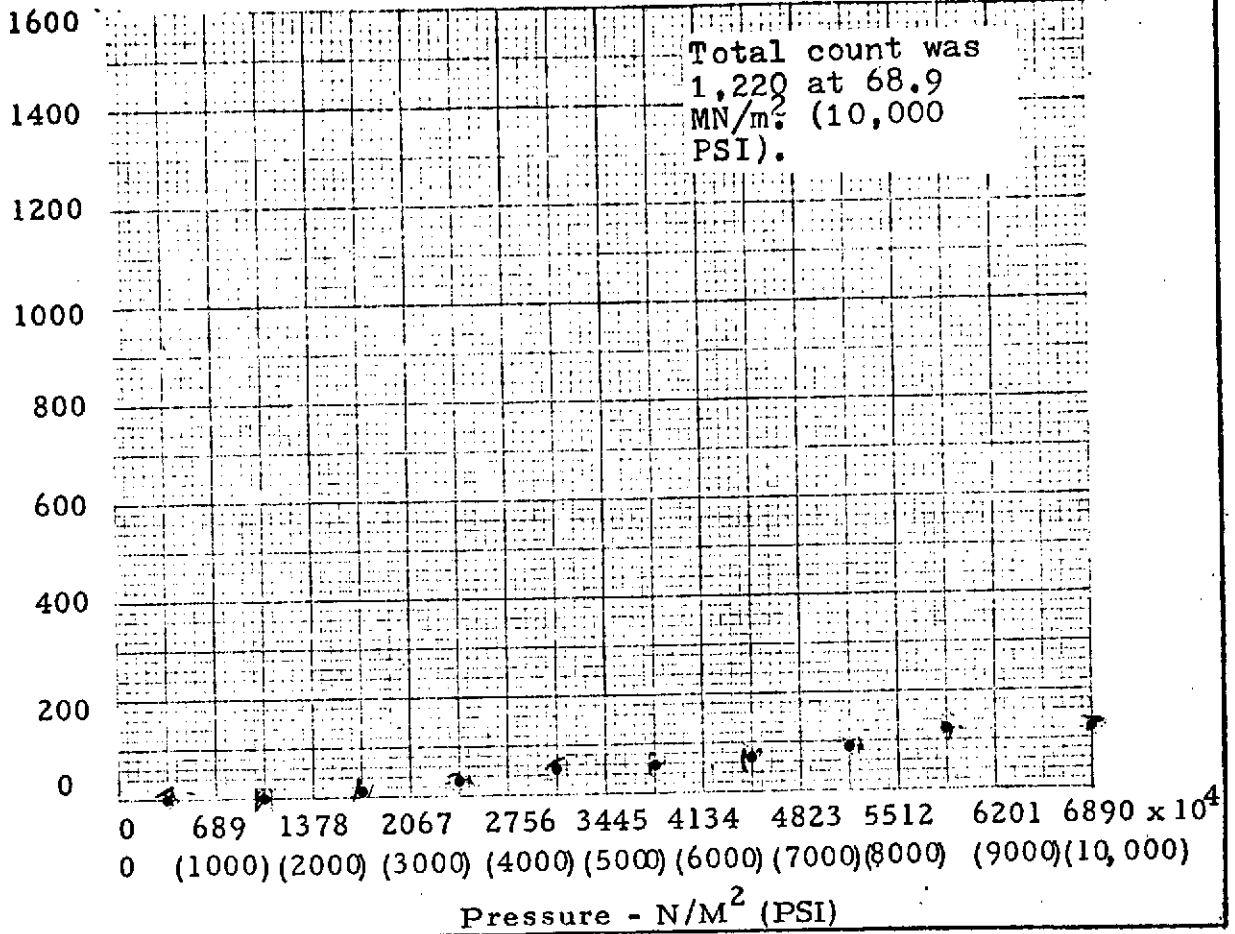
Planned flaw 6.3500 mm. long x $\frac{1}{2}$ land width
(0.25 in.)
(Produced by electric discharge machining
to a depth of 0.2540 mm. or 0.010 in.)

FIGURE B-16

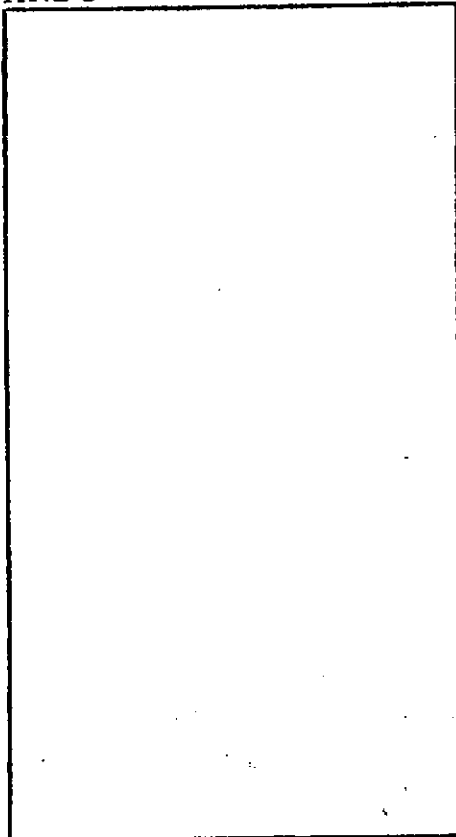
Panel No. N-28A

Summation $\times 10^{-1}$

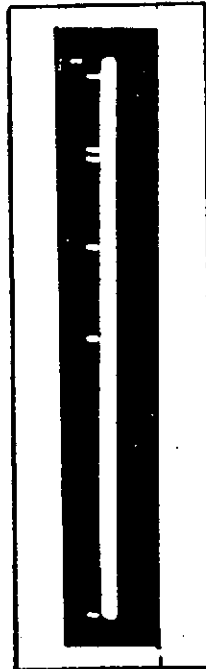
A E



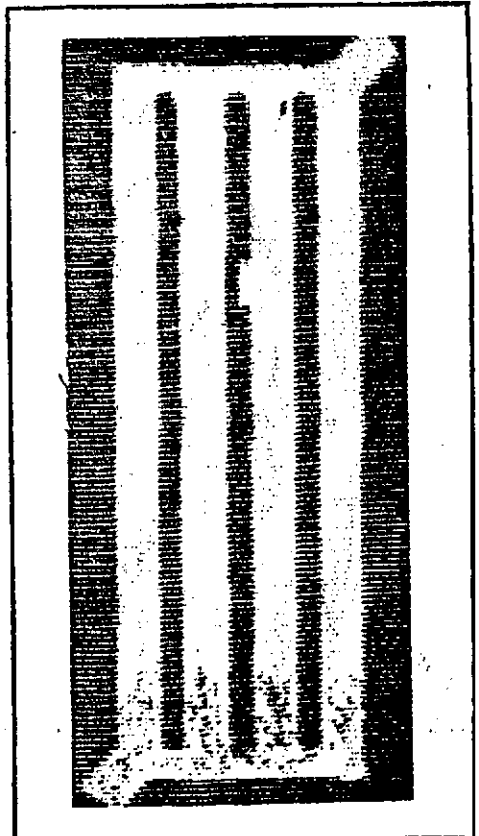
HNDT



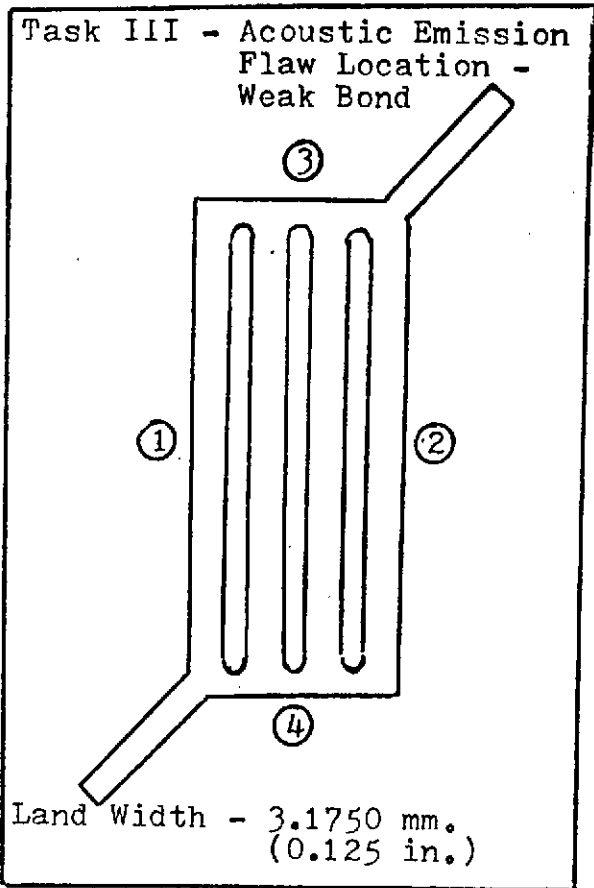
AE
FLAW LOCATOR
CENTER LAND



UT



ELECTROFORMED PANEL NO. N-43



BASEPLATE

MATERIAL: Nickel 200

CENTER LAND FLATNESS VARIATION:
0.006 in. (0.1524 mm.)

THICKNESS:	MM.	INCHES
①	6.2281	0.2452
②	6.2560	0.2463
③	6.2484	0.2460
④	6.2484	0.2460

COVERPLATE

MATERIAL: Electroformed Nickel

THICKNESS:	MM.	INCHES
①	1.2040	0.0474
②	1.2217	0.0481
③	1.3056	0.0514
④	1.3132	0.0517

CENTER LAND DEFECT

METALLOGRAPHIC ANALYSIS: Not Applicable

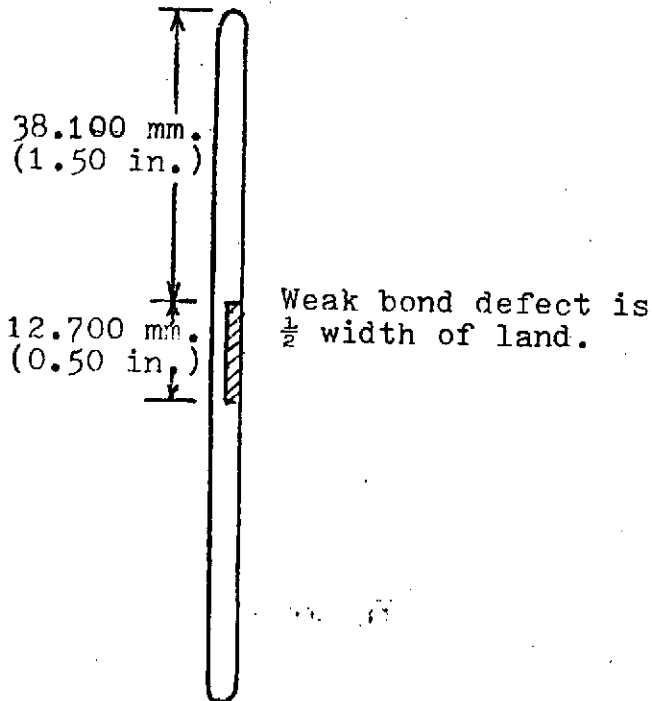
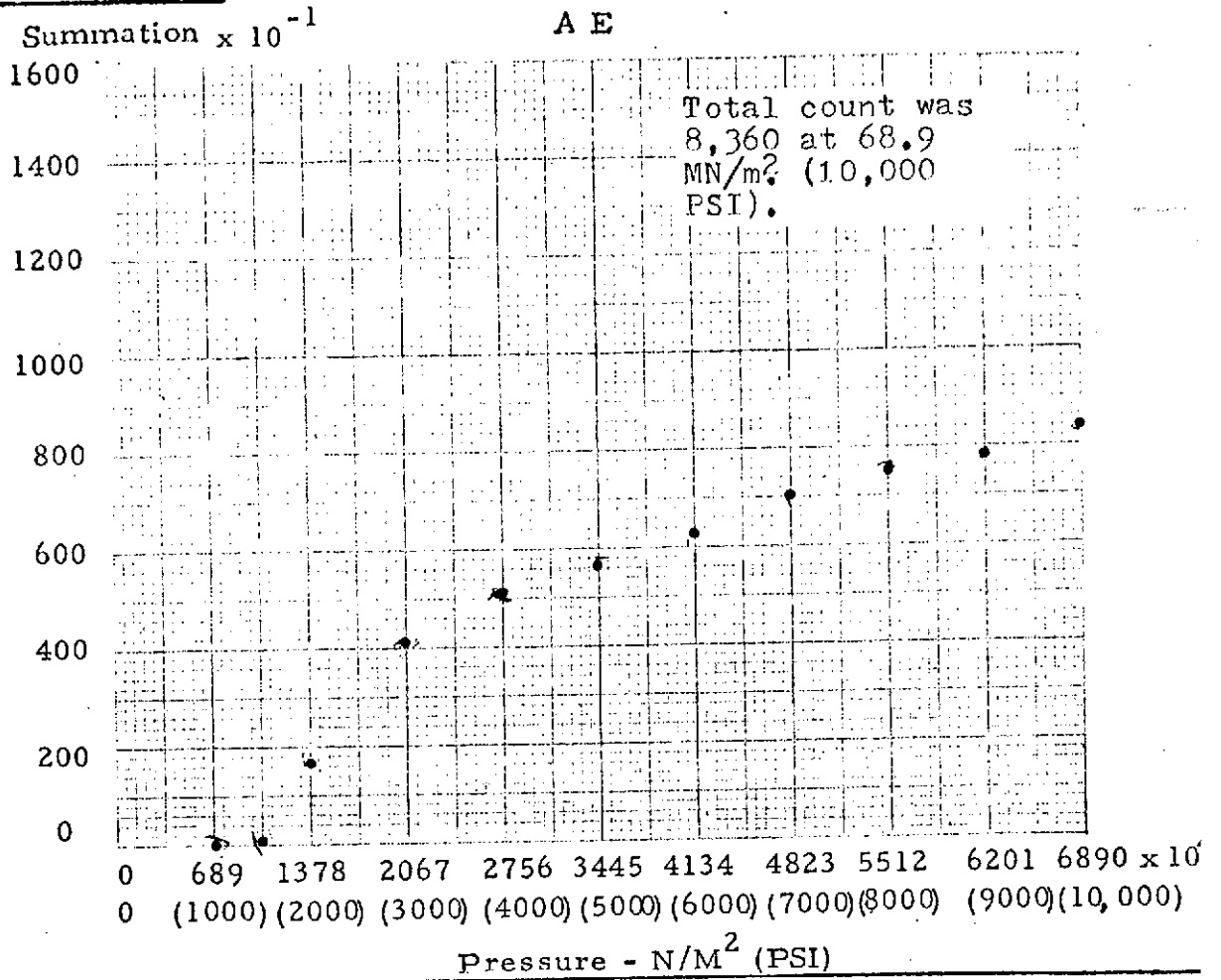
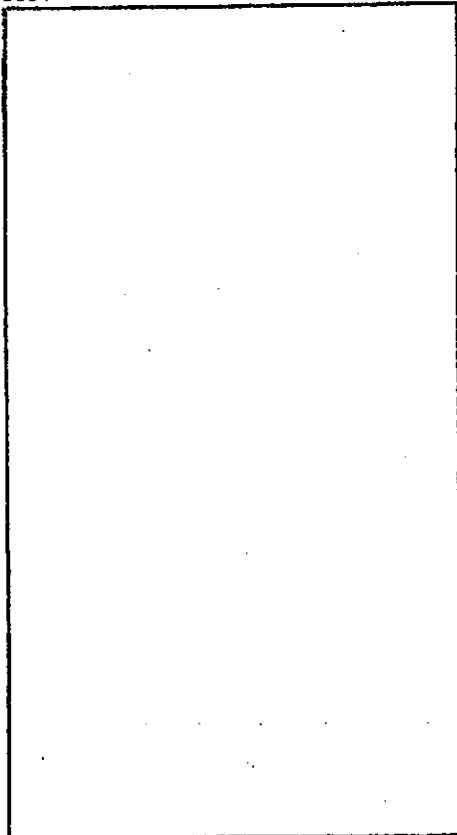


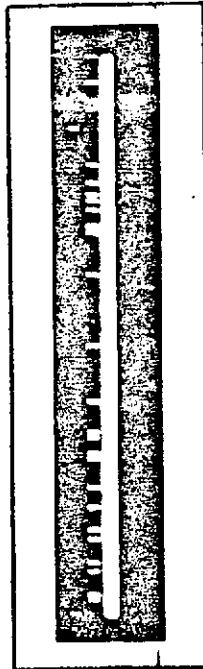
FIGURE B-17



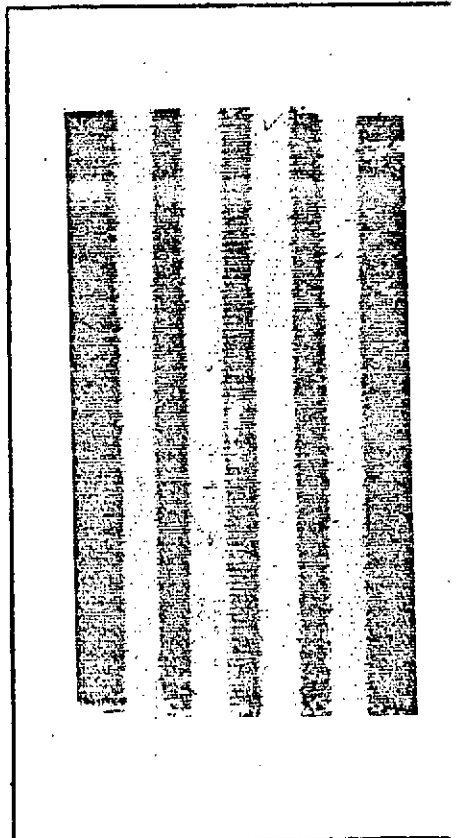
HNDT



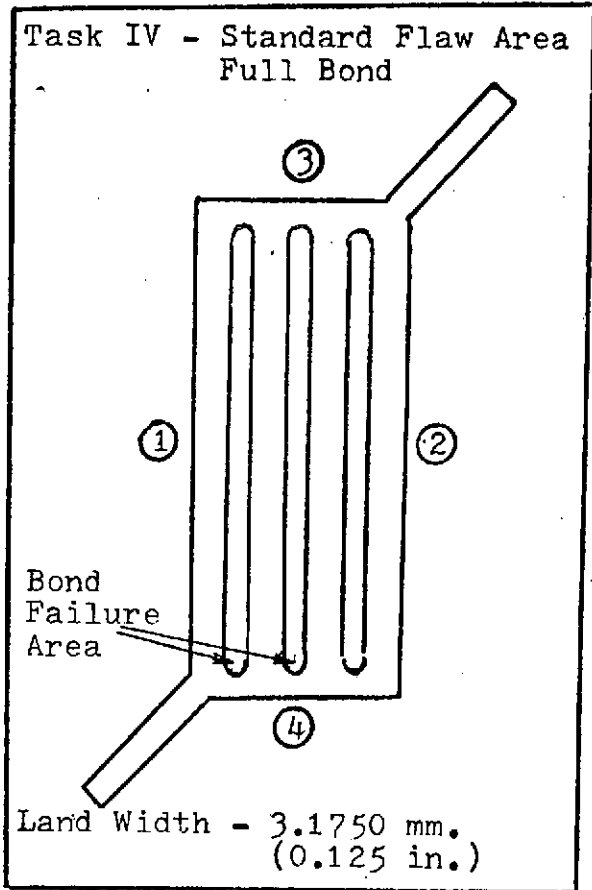
A E
FLAW LOCATOR
CENTER LAND



UT



ELECTROFORMED PANEL NO. N-11 "A"



BASEPLATE

MATERIAL: Nickel 200

CENTER LAND FLATNESS VARIATION:
0.0015 in. (0.0381 mm.)

THICKNESS:	MM.	INCHES
①	6.1976	0.2440
②	6.1620	0.2426
③	6.2179	0.2448
④	6.1646	0.2427

COVERPLATE

MATERIAL: Electroformed Nickel

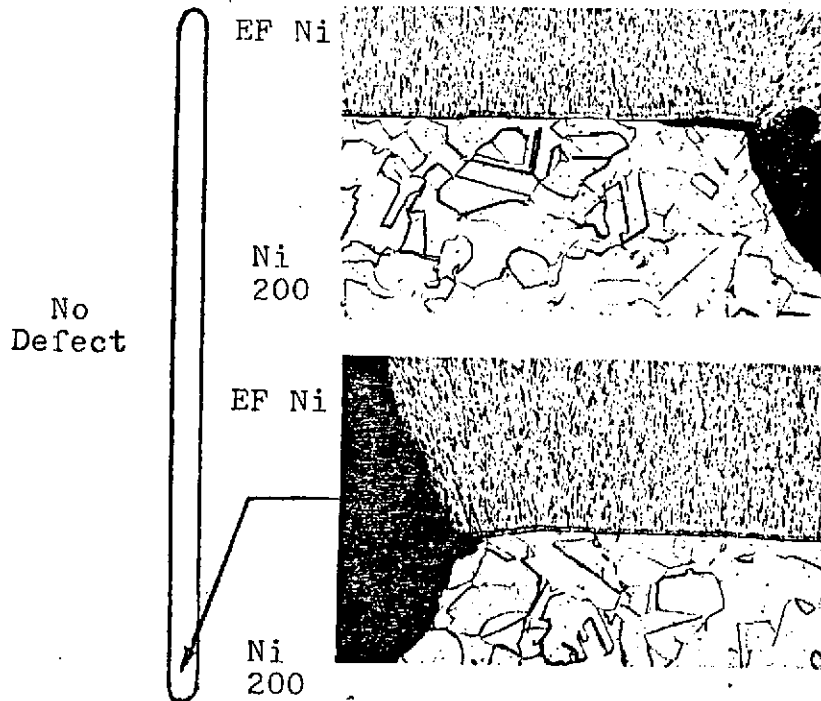
THICKNESS:	MM.	INCHES
①	0.9957	0.0392
②	1.0058	0.0396
③	0.9525	0.0375
④	1.0033	0.0395

PRESSURE REQUIRED TO FAIL BOND:

Bonds failed at a pressure of
 $6.9 \times 10^7 \text{ N/m}^2$ (10,000 psi).
Failure occurred at ends of Lands
1 and 2.

CENTER LAND DEFECT

METALLOGRAPHIC ANALYSIS:



Section from lower
end of first land
showing edge bond
separation.
Magnification 50X.

Section from lower
end of second land
showing bond intact.
Failure appears to
be starting.
Magnification 50X.

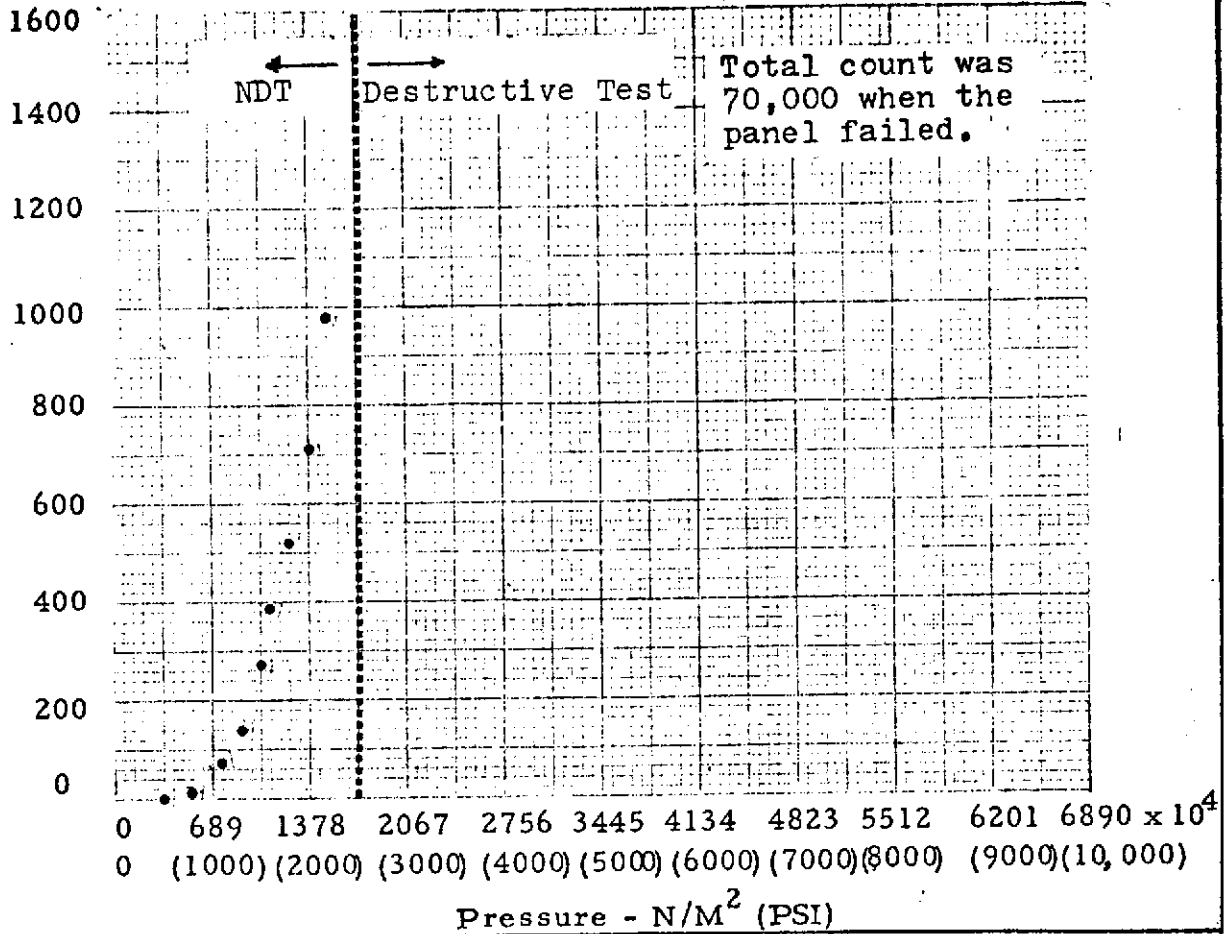
FIGURE C-1

Panel No. N-11A

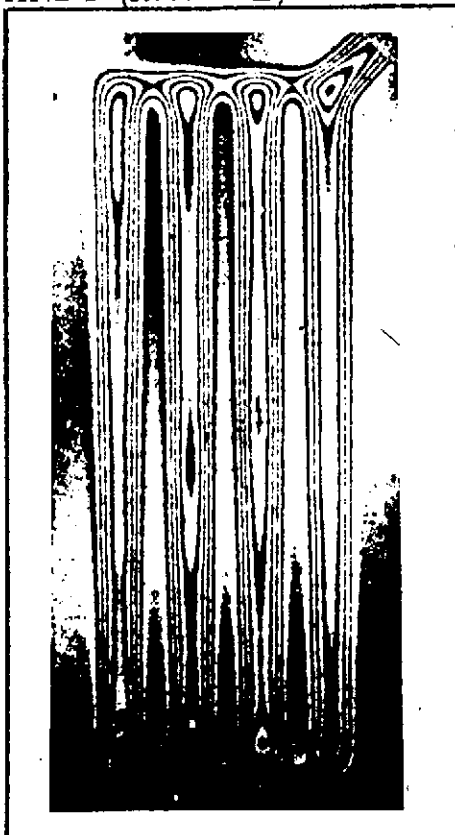
-1

Summation x 10

A E

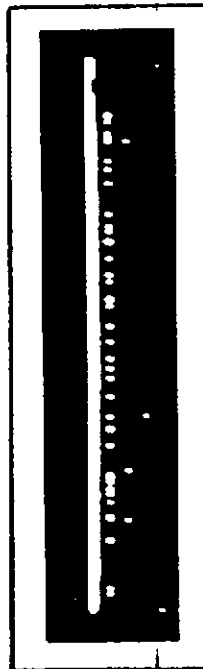


HNDT (After AE)

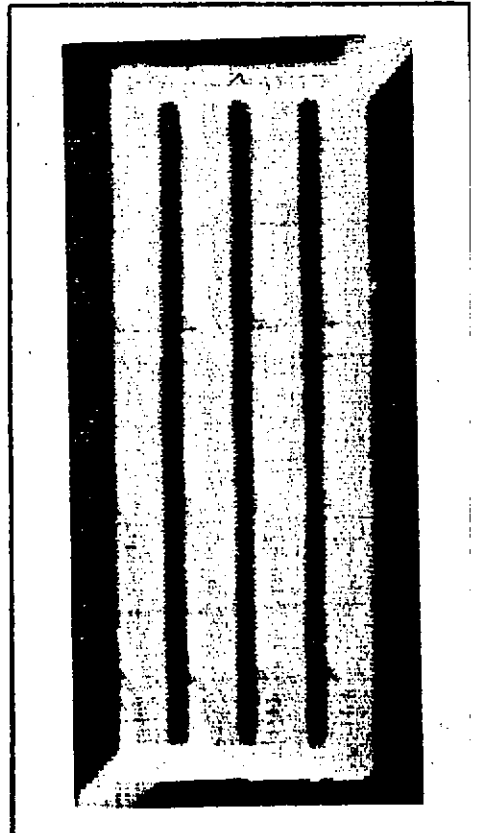


Press. - 20.7×10^5 N/M²
(300 PSI)

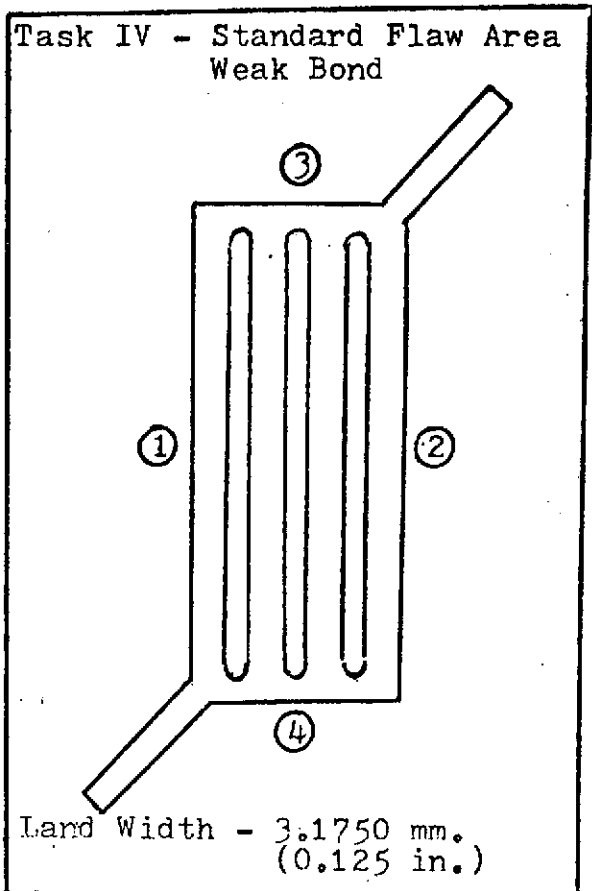
AE
FLAW LOCATOR
CENTER LAND



UT



ELECTROFORMED PANEL NO. N-29



BASEPLATE

MATERIAL: Nickel 200

CENTER LAND FLATNESS VARIATION:
'0.0015 in. (0.0381 mm.)

THICKNESS:	MM.	INCHES
①	6.3119	0.2485
②	6.3144	0.2486
③	6.3068	0.2483
④	6.2738	0.2470

COVERPLATE

MATERIAL: Electroformed Nickel

THICKNESS:	MM.	INCHES
①	0.9855	0.0388
②	0.9576	0.0377
③	0.9525	0.0375
④	1.0008	0.0394

PRESSURE REQUIRED TO FAIL BOND:

Panel exhibited slight bulging at
 6.90×10^7 N/m² (10,000 psi).

CENTER LAND DEFECT

METALLOGRAPHIC ANALYSIS:

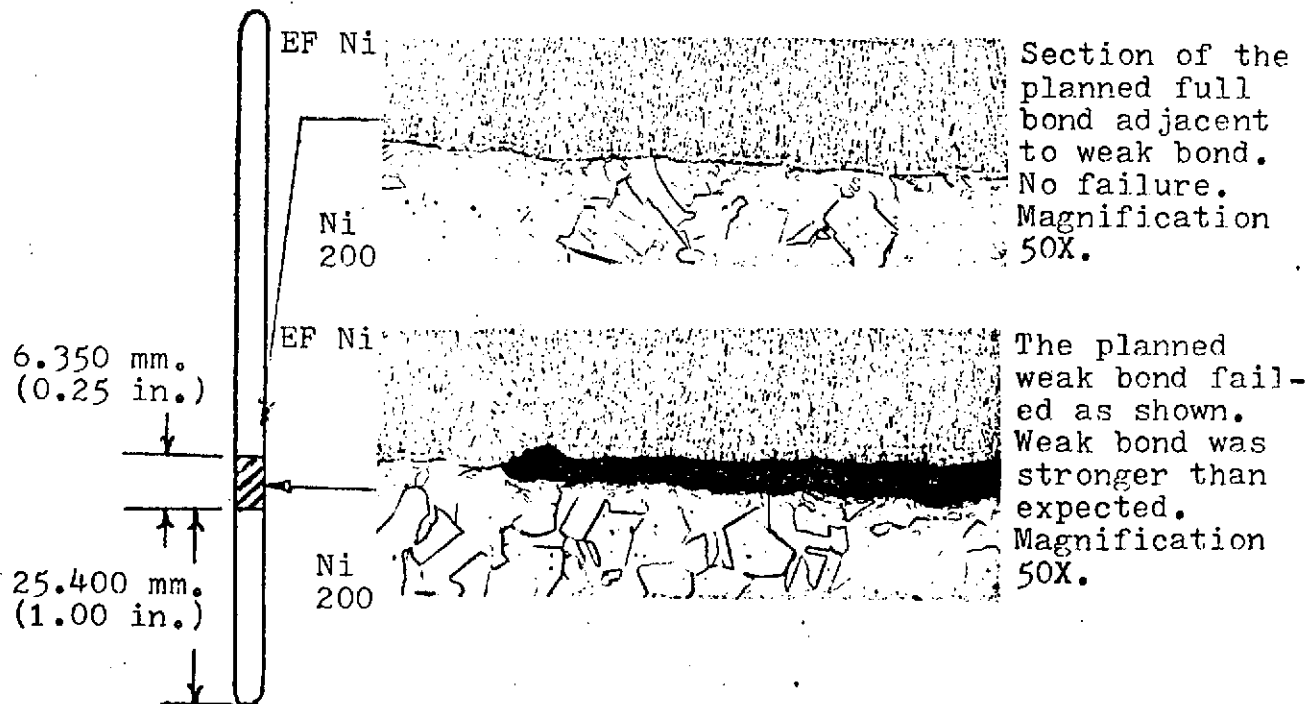
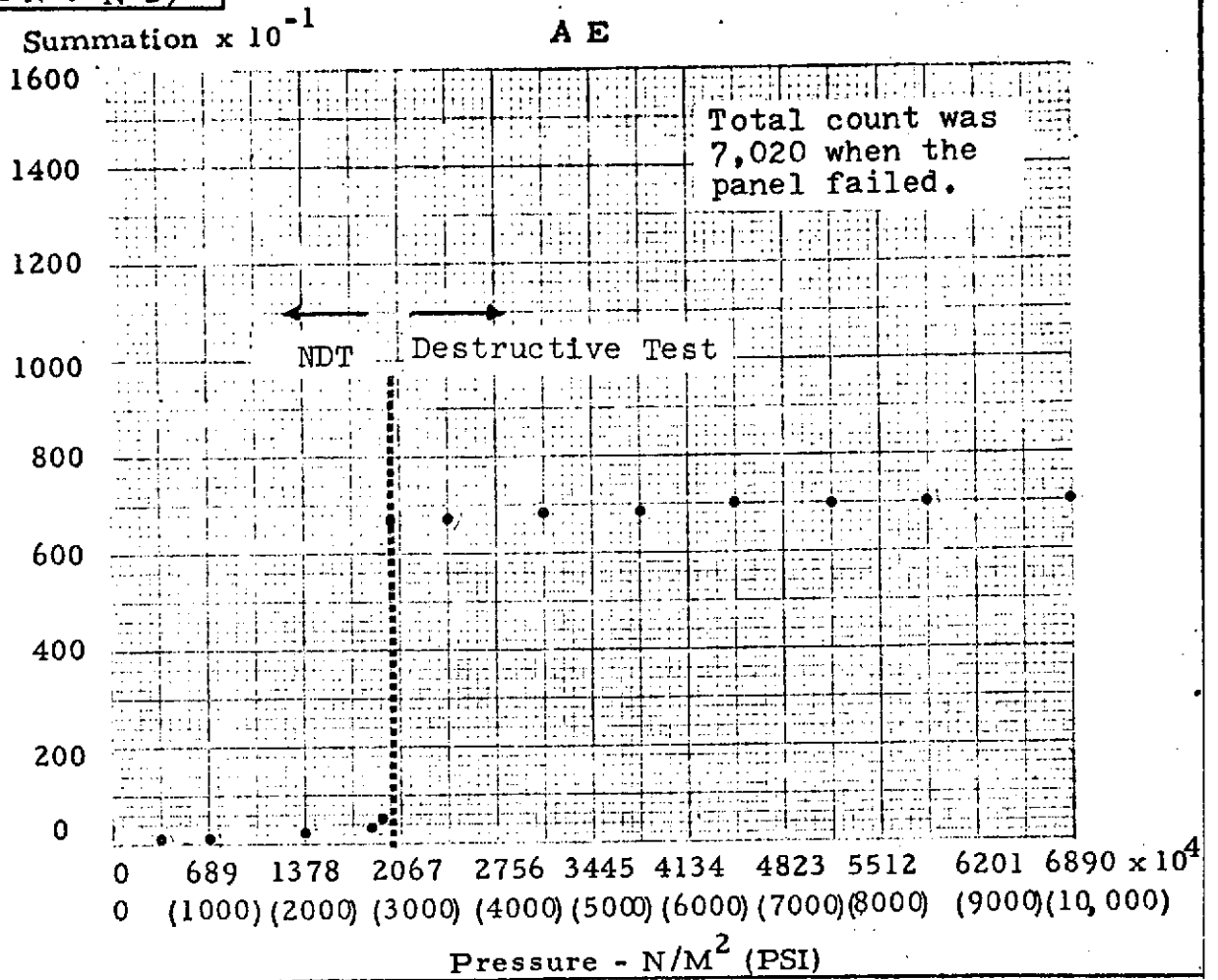
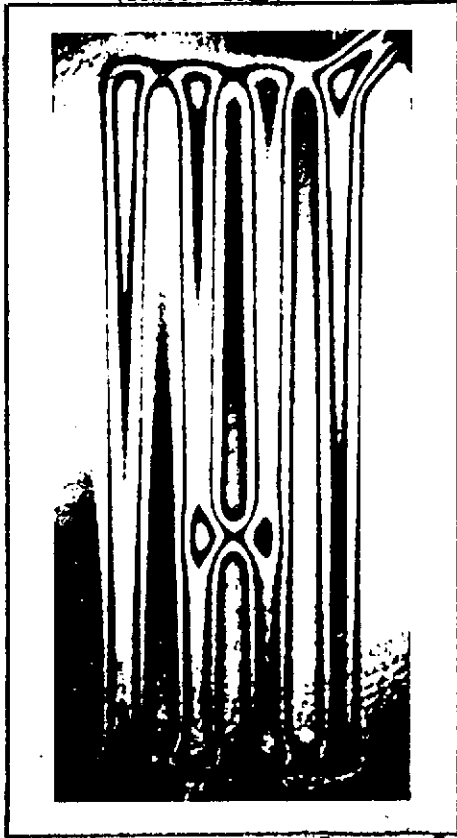


FIGURE C-2

Panel No. N-29

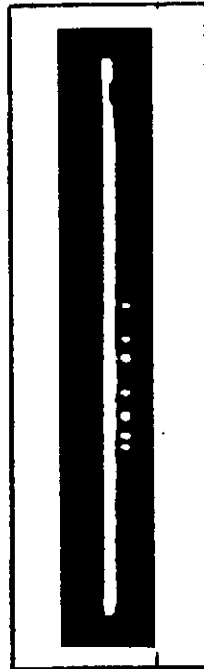


HNDT (After AE)

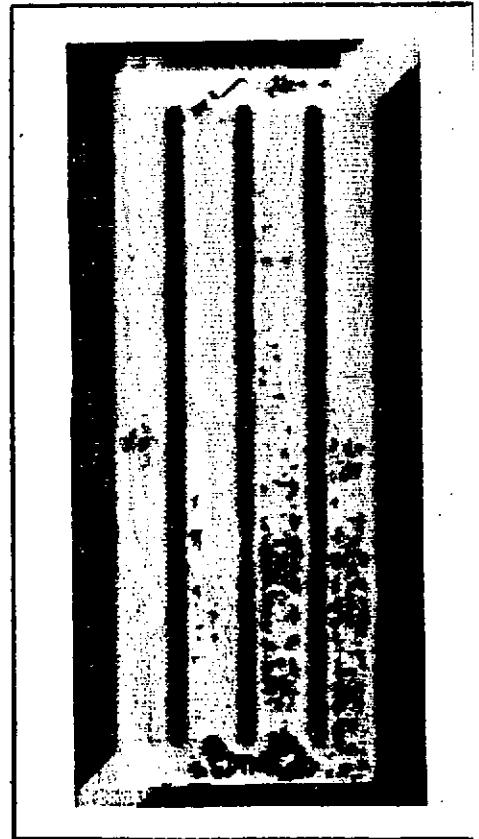


Press. - $13.8 \times 10^5 N/M^2$
(200 PSI)

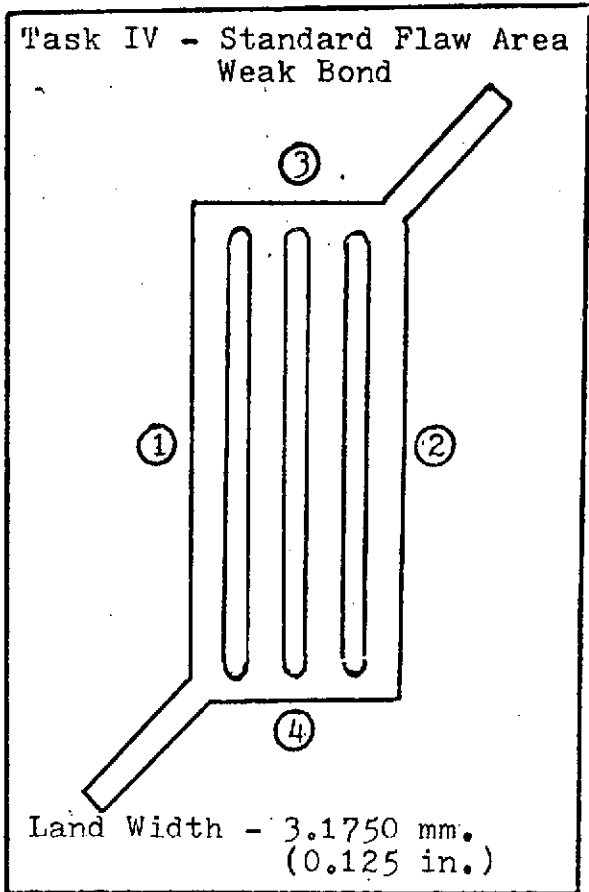
AE
FLAW LOCATOR
CENTER LAND



UT



ELECTROFORMED PANEL NO. N -30



BASEPLATE

MATERIAL: Nickel 200

CENTER LAND FLATNESS VARIATION:
0.006 in. (0.1524 mm.)

THICKNESS:	MM.	INCHES
①	6.2662	0.2467
②	6.2687	0.2468
③	6.2738	0.2470
④	6.2636	0.2466

COVERPLATE

MATERIAL: Electroformed Nickel

THICKNESS:	MM.	INCHES
①	0.9957	0.0392
②	0.9677	0.0381
③	0.9474	0.0373
④	0.9601	0.0378

PRESSURE REQUIRED TO FAIL BOND:

Bond failed at a pressure of
 $6.90 \times 10^7 \text{ N/m}^2$ (10,000 psi).

CENTER LAND DEFECT

METALLOGRAPHIC ANALYSIS:

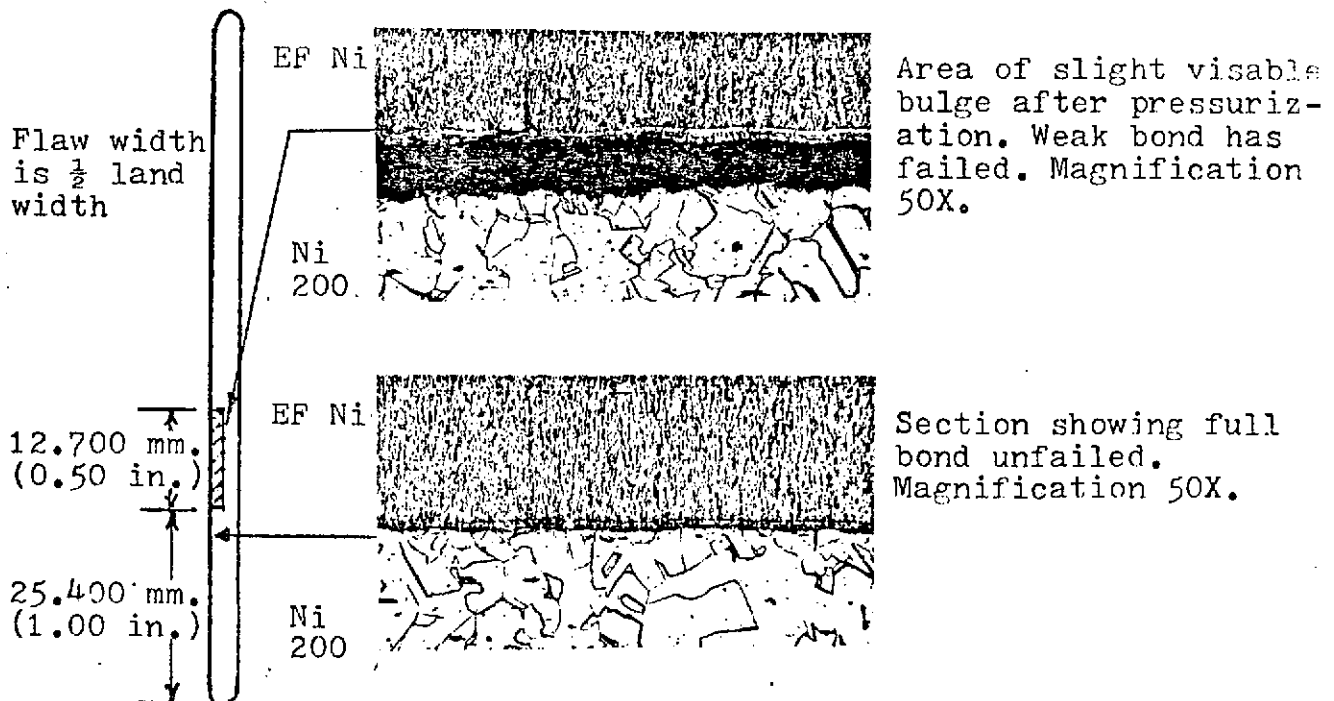
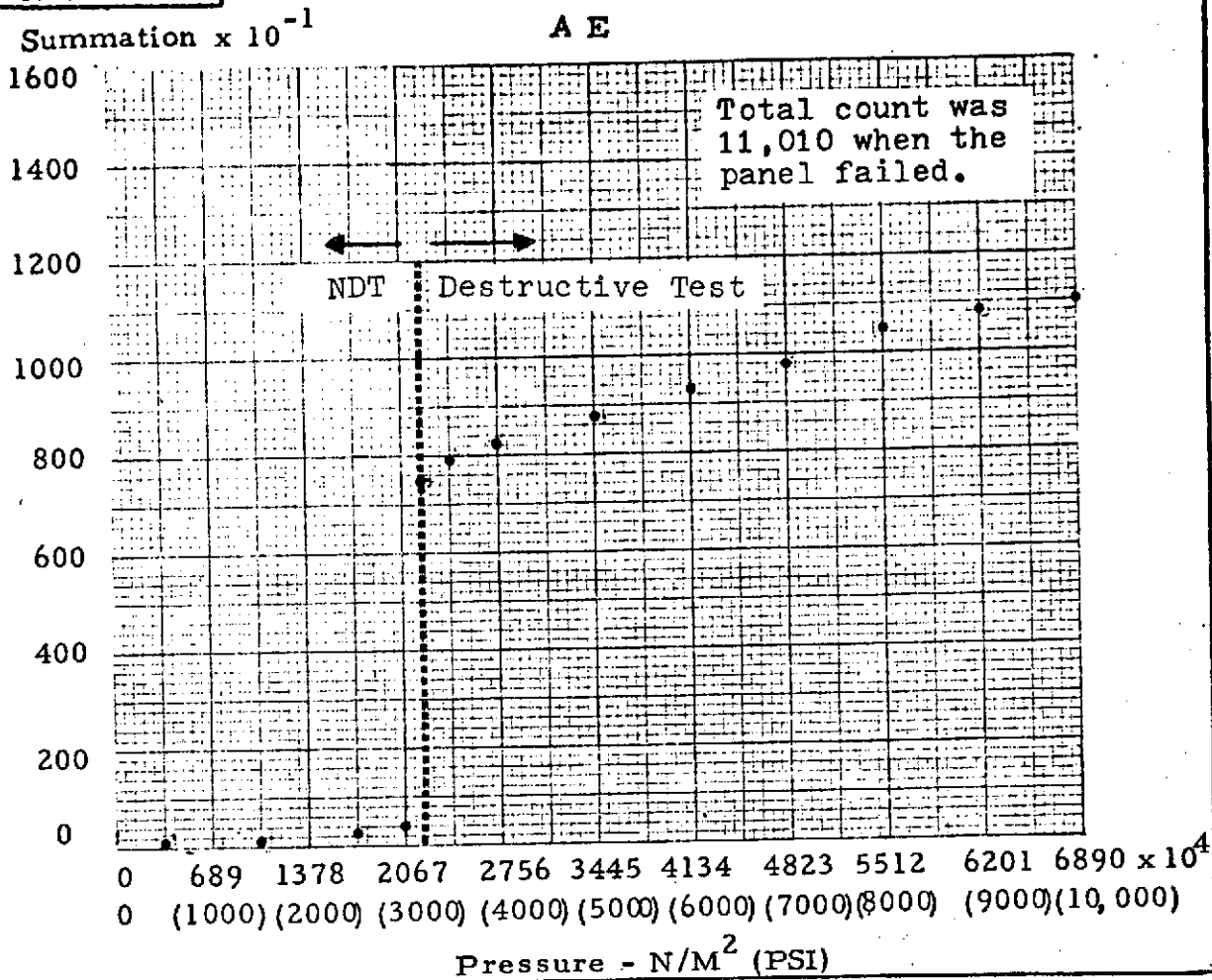


FIGURE G-3

Panel No. N-30



HNDT (Before AE)



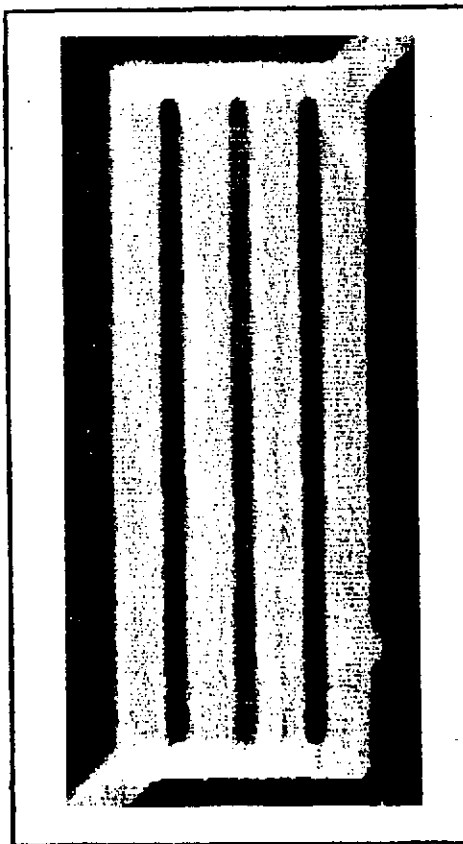
Press. - $20.7 \times 10^5 N/M^2$
(300 PSI)

AE
FLAW LOCATOR
CENTER LAND

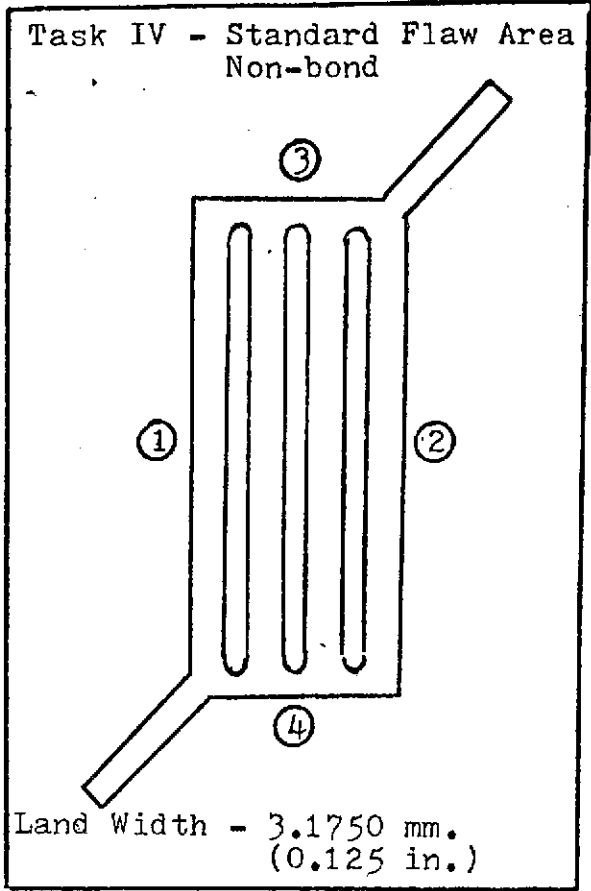


75

UT



ELECTROFORMED PANEL NO. N-38



BASEPLATE

MATERIAL: Nickel 200

CENTER LAND FLATNESS VARIATION:
0.001 in. (0.0254 mm.)

THICKNESS:	MM.	INCHES
①	6.2814	0.2473
②	6.2738	0.2470
③	6.2763	0.2471
④	6.2713	0.2469

COVERPLATE

MATERIAL: Electroformed Nickel

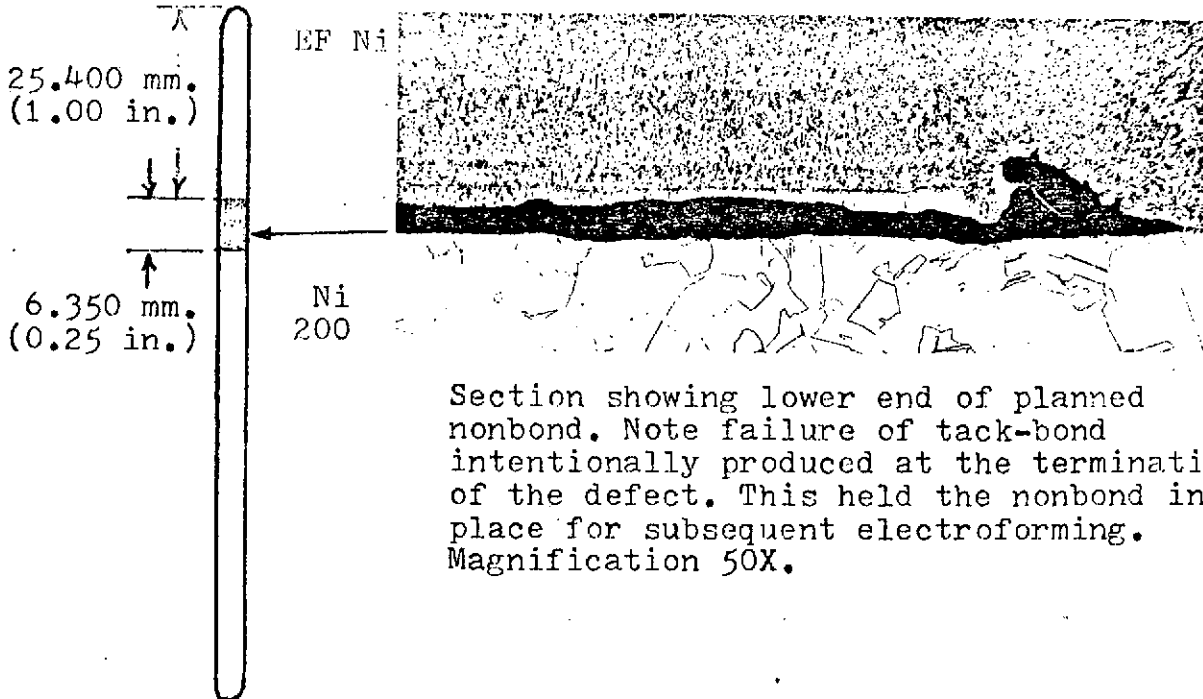
THICKNESS:	MM.	INCHES
①	0.9220	0.0363
②	0.9195	0.0362
③	0.9398	0.0370
④	0.9550	0.0376

PRESSURE REQUIRED TO FAIL BOND:

Bond failed at a pressure of
 $3.93 \times 10^7 \text{ N/m}^2$ (5,700 psi)

CENTER LAND DEFECT

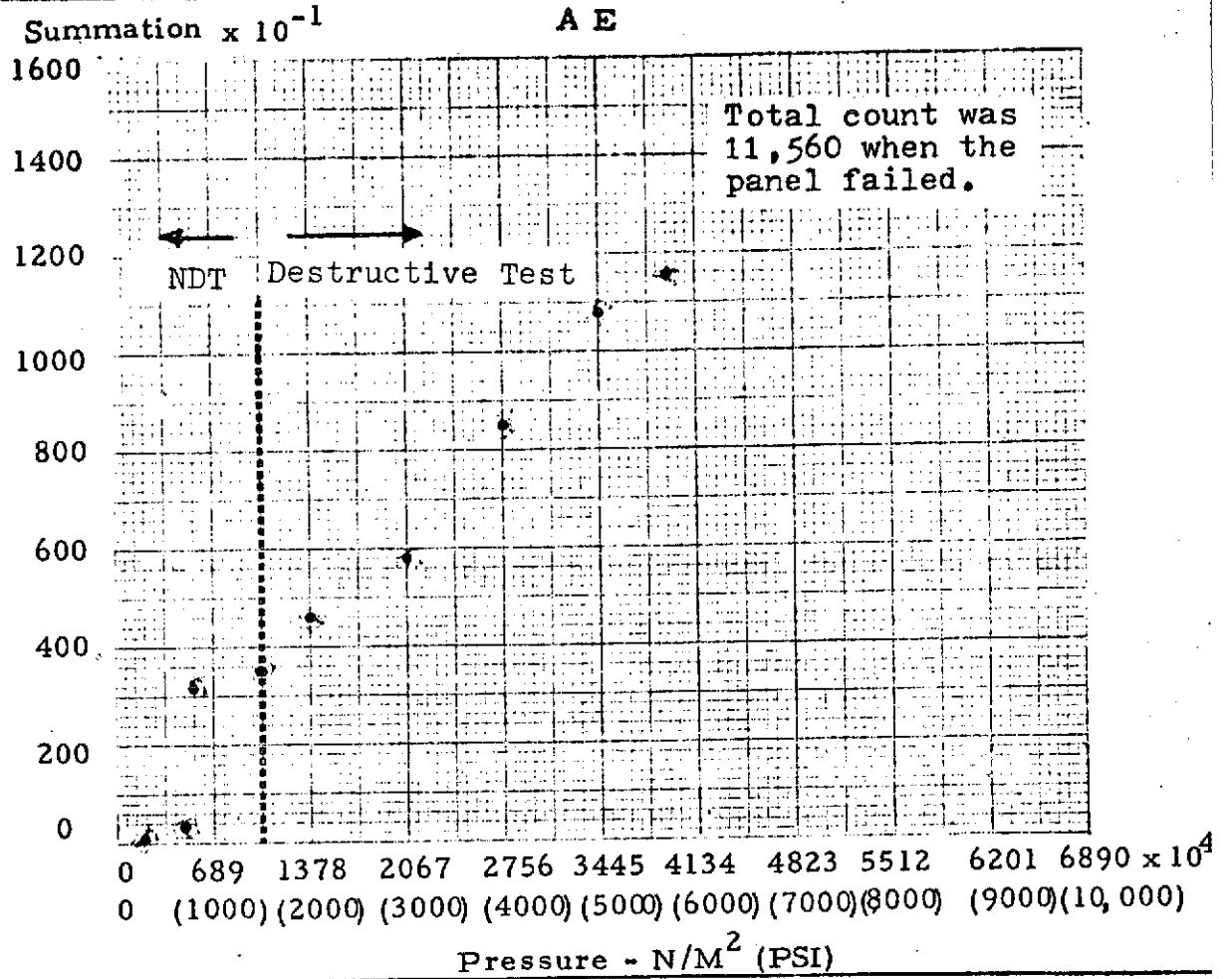
METALLOGRAPHIC ANALYSIS:



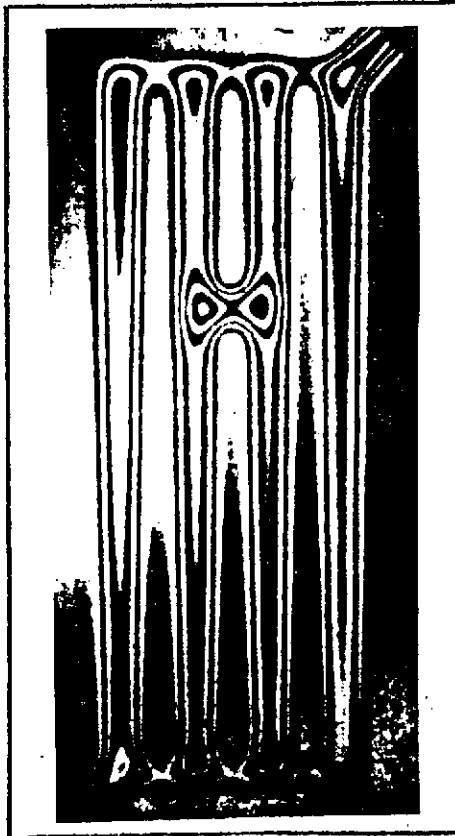
Section showing lower end of planned nonbond. Note failure of tack-bond intentionally produced at the termination of the defect. This held the nonbond in place for subsequent electroforming. Magnification 50X.

FIGURE C-4

Panel No. N-38

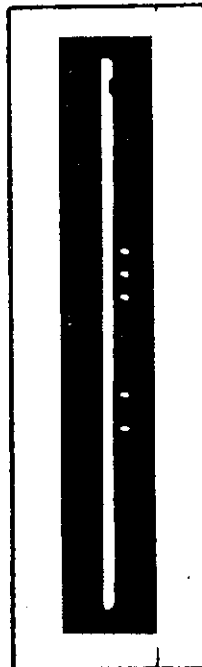


HNDT (After AE)

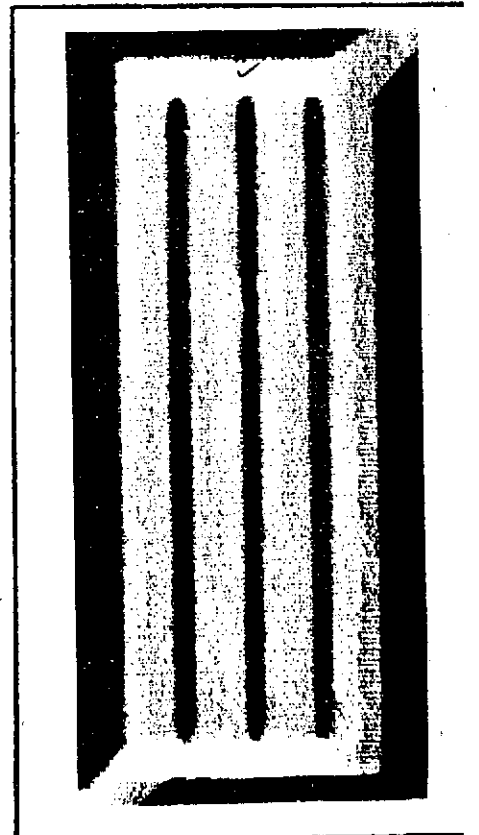


Press. - 13.8×10^5 N/M²
(220 PSI)

AE
FLAW LOCATOR
CENTER LAND



UT



ELECTROFORMED PANEL NO. N-31

BASEPLATE

MATERIAL: Nickel 200
 CENTER LAND FLATNESS VARIATION:
 0.004 in. (0.1016 mm.)

THICKNESS:	MM.	INCHES
①	6.3500	0.2500
②	6.3373	0.2495
③	6.3627	0.2505
④	6.2788	0.2472

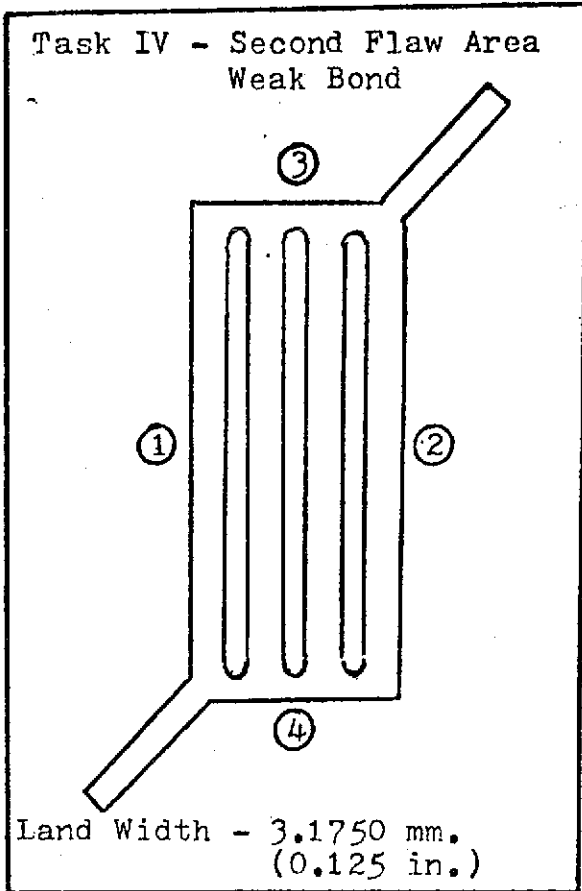
COVERPLATE

MATERIAL: Electroformed Nickel

THICKNESS:	MM.	INCHES
①	0.9474	0.0373
②	1.0008	0.0394
③	0.9881	0.0389
④	1.0693	0.0421

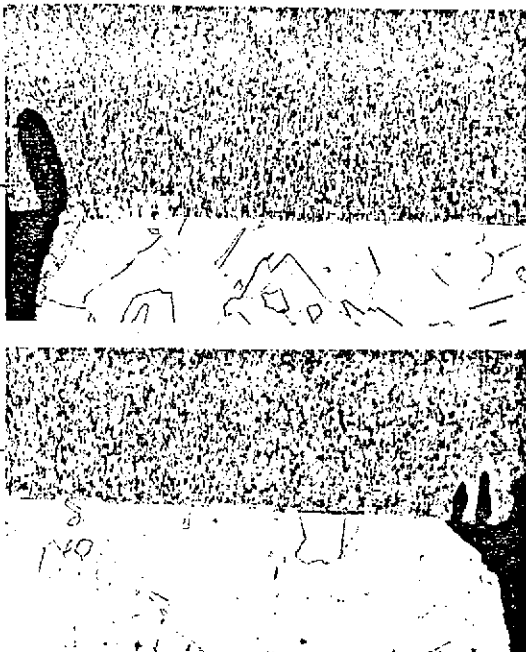
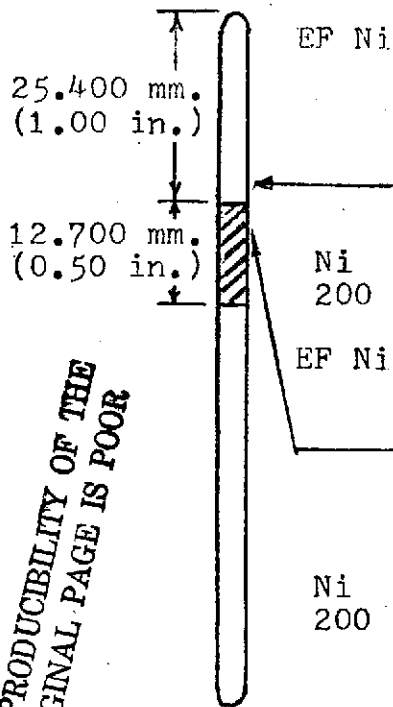
PRESSURE REQUIRED TO FAIL BOND:

Bond failed at a pressure of
 5.87×10^7 N/m² (8,500 psi)



CENTER LAND DEFECT

METALLOGRAPHIC ANALYSIS:



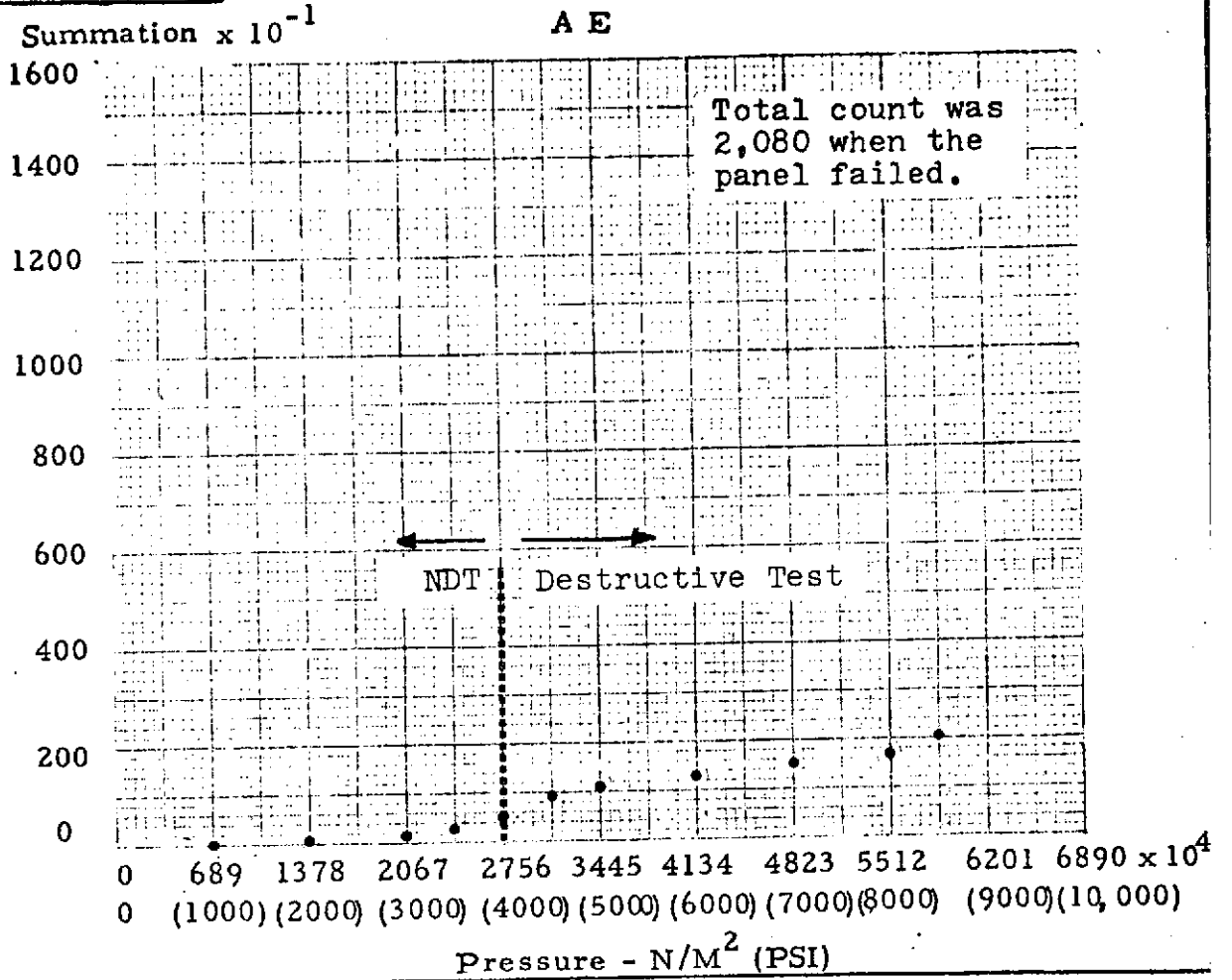
Full bond section.
 Note tack-bonding
 on land edge.
 Failure appeared
 to start in EF Ni.
 Magnification 50X.

Weak bond section.
 Bond failure was
 initiated at edge
 of land.
 Magnification 50X.

REPRODUCIBILITY OF THE
 ORIGINAL PAGE IS POOR

FIGURE C-5
 78

Panel No. N-31



HNDT (After AE)

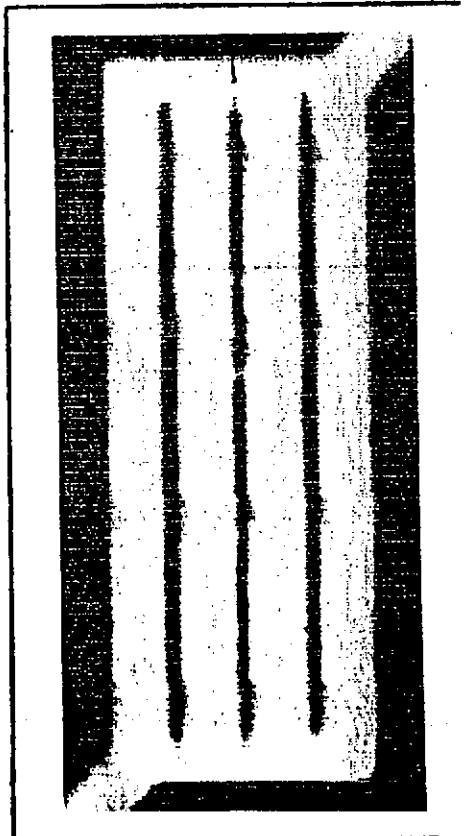


Press. $20.7 \times 10^5 N/M^2$
(300 PSI)

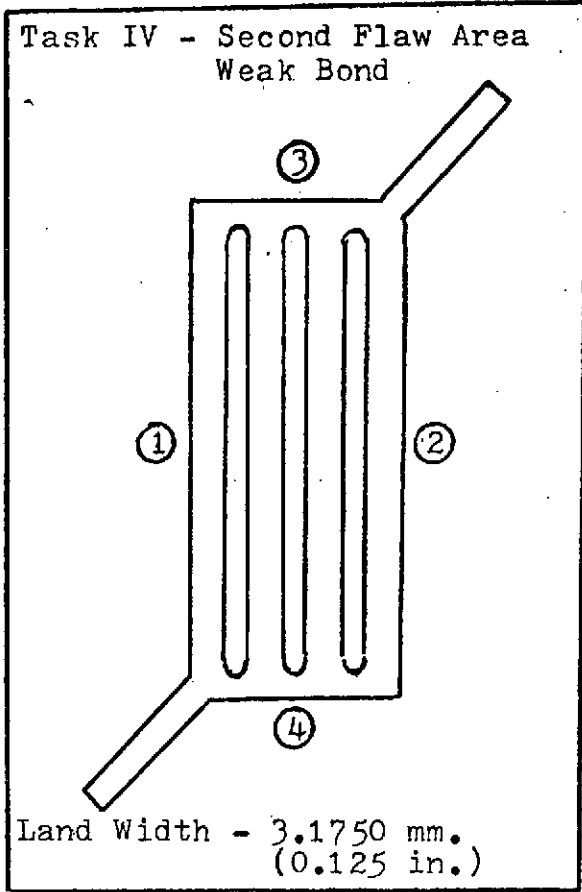
AE
FLAW LOCATOR
CENTER LAND



UT



ELECTROFORMED PANEL NO. N-32



BASEPLATE

MATERIAL: Nickel 200

CENTER LAND FLATNESS VARIATION:
0.0015 in. (0.0381 mm.)

THICKNESS:	MM.	INCHES
①	6.3830	0.2513
②	6.3932	0.2517
③	6.3754	0.2510
④	6.3271	0.2491

COVERPLATE

MATERIAL: Electroformed Nickel

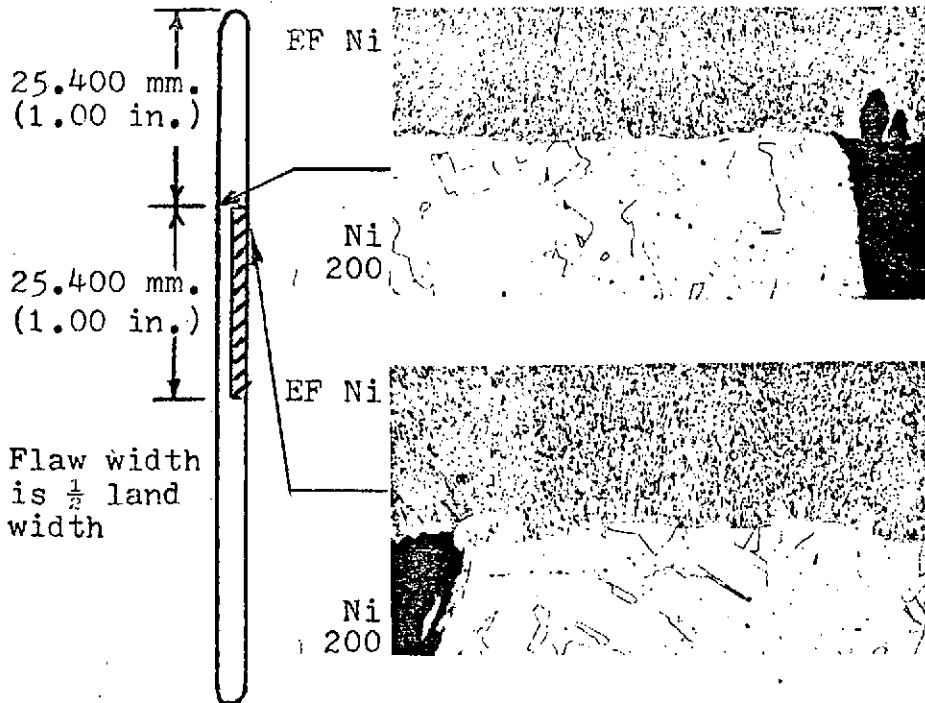
THICKNESS:	MM.	INCHES
①	0.9754	0.0384
②	0.9550	0.0376
③	0.9576	0.0377
④	0.9982	0.0393

PRESSURE REQUIRED TO FAIL BOND:

Panel withstood a pressure of
 $6.9 \times 10^7 \text{ N/m}^2$ (10,000 psi).
Channel buckling was initiated.

CENTER LAND DEFECT

METALLOGRAPHIC ANALYSIS:

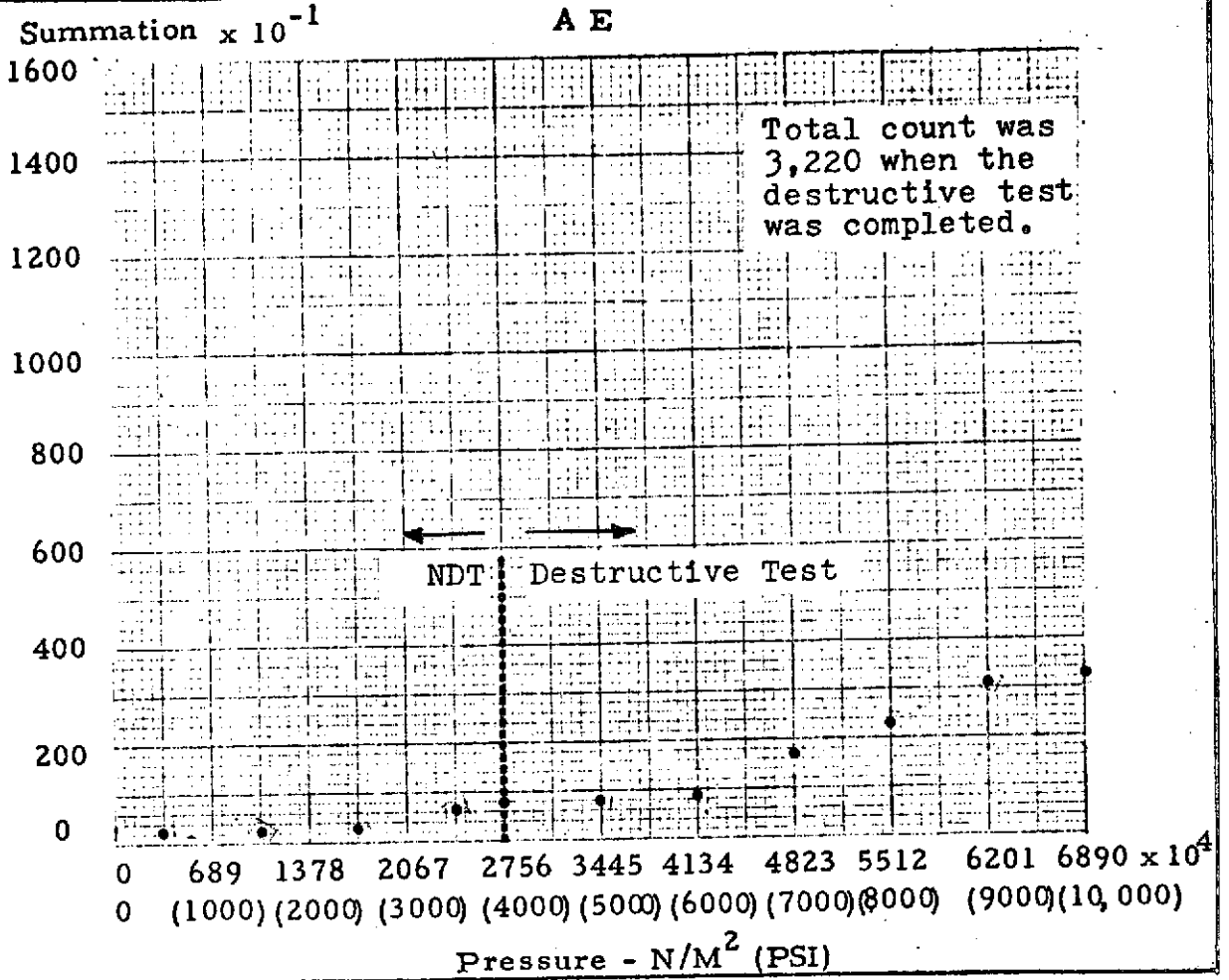


Full bond section.
Some failure was
initiated at land
edge. Magnification
50X.

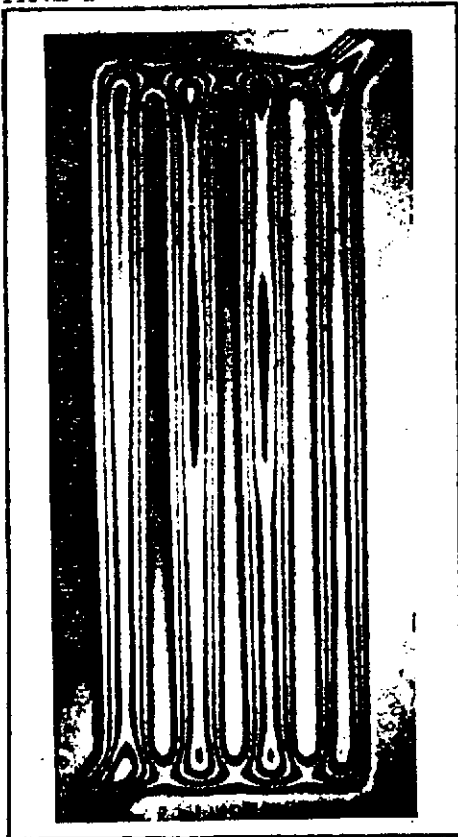
Planned defect area.
No bond failure is
indicated. Some
intermittent failure
may have occurred.
Magnification 50X.

FIGURE C-6

Panel No. N-32

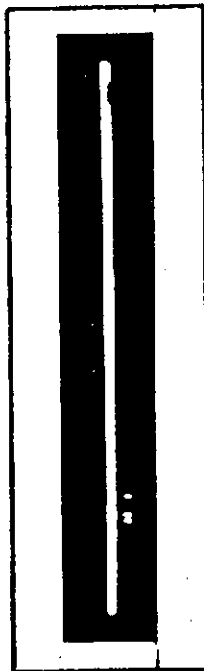


HNDT (After AE)

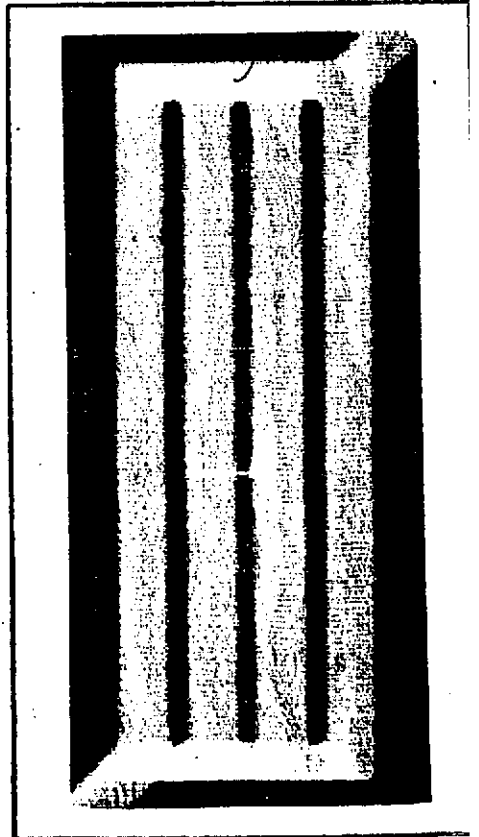


Press. $20.7 \times 10^5 N/M^2$
(300 PSI)

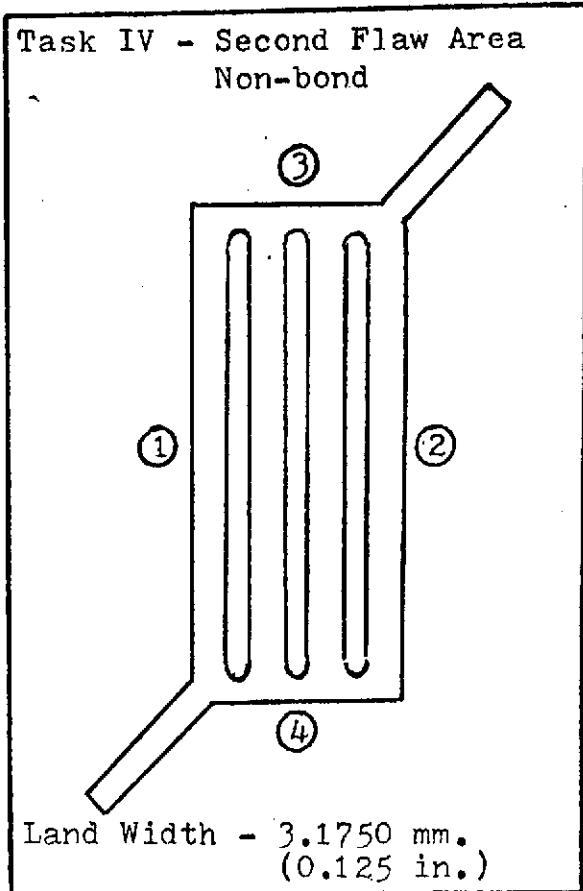
AE
FLAW LOCATOR
CENTER LAND



UT



ELECTROFORMED PANEL NO. N-39



BASEPLATE

MATERIAL: Nickel 200

CENTER LAND FLATNESS VARIATION:
0.003 in. (0.0762 mm.)

THICKNESS:	MM.	INCHES
①	6.2788	0.2472
②	6.2713	0.2469
③	6.2662	0.2467
④	6.2636	0.2466

COVERPLATE

MATERIAL: Electroformed Nickel

THICKNESS:	MM.	INCHES
①	0.8534	0.0336
②	0.8865	0.0349
③	0.9957	0.0392
④	0.9754	0.0384

PRESSURE REQUIRED TO FAIL BOND:

Bond failed at a pressure of
 $1.66 \times 10^7 \text{ N/m}^2$ (2,400 psi)

CENTER LAND DEFECT

METALLOGRAPHIC ANALYSIS:

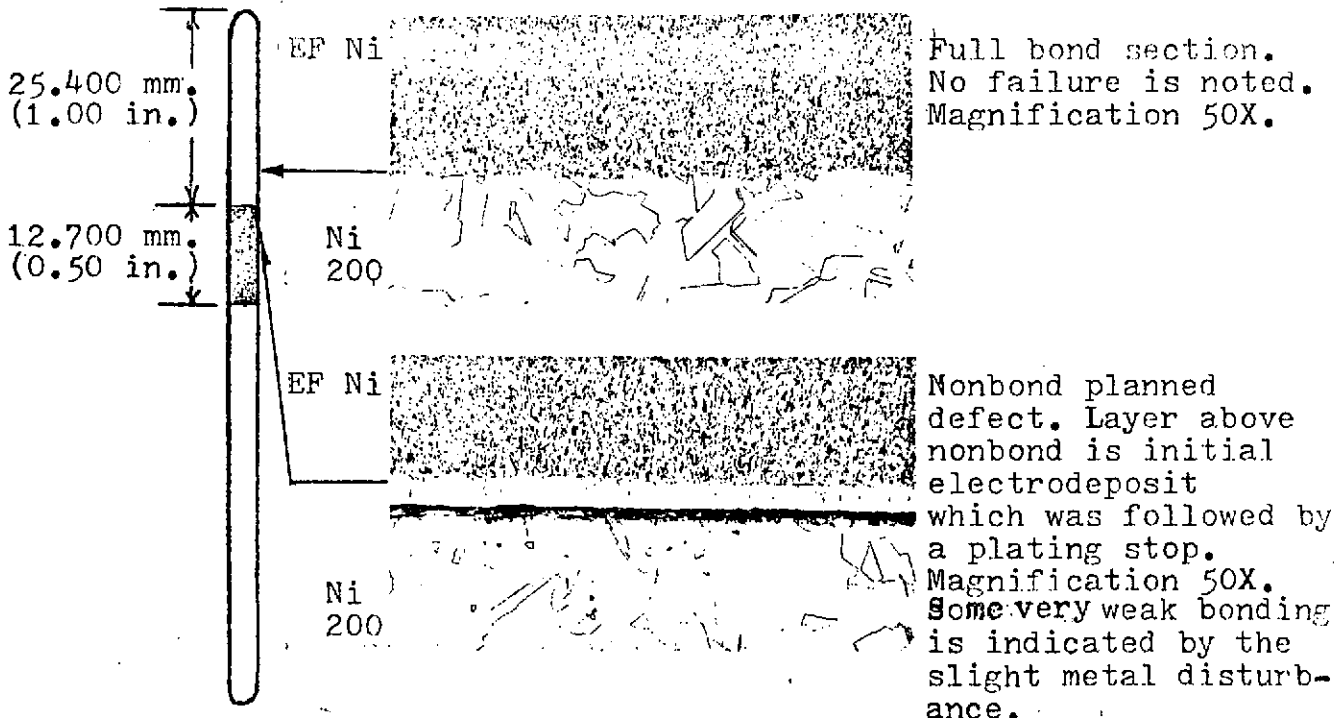
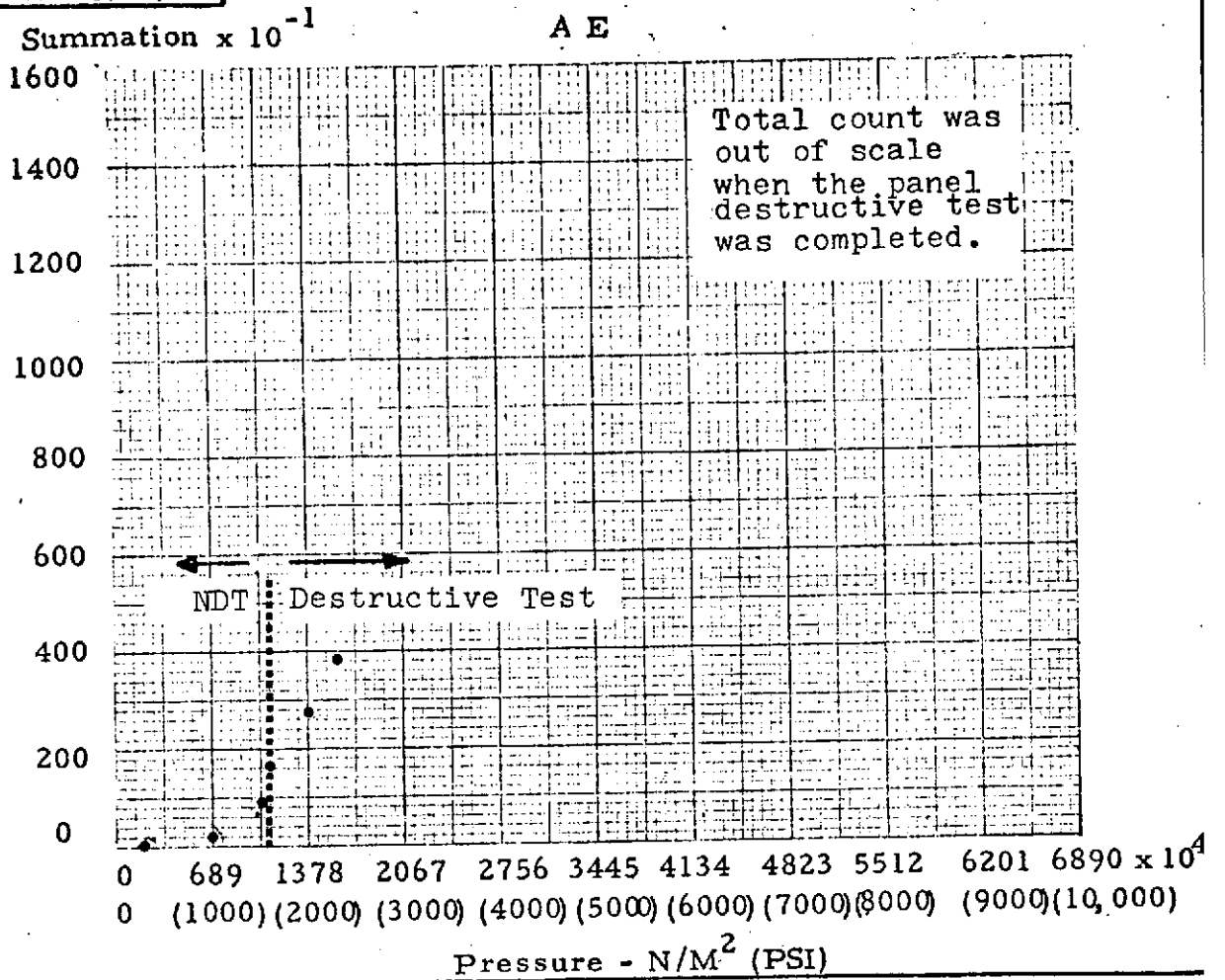


FIGURE C-7

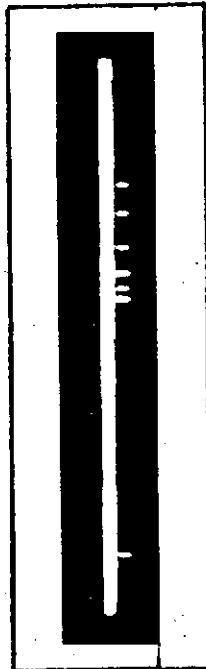
Panel No. N-39



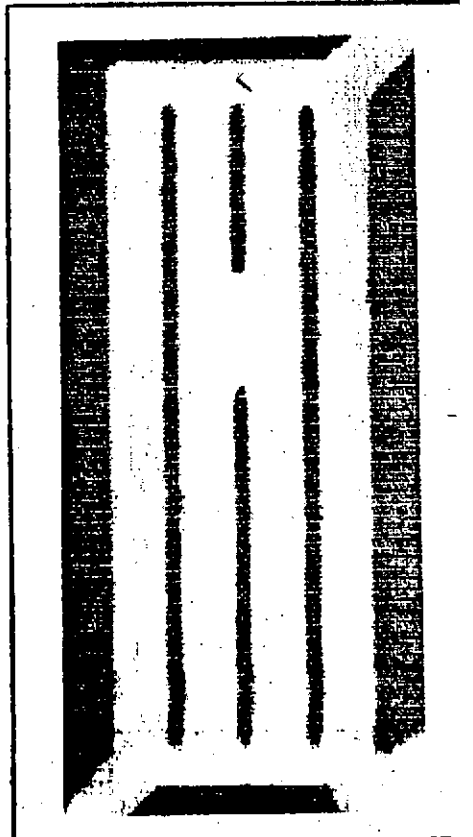
HNDT (Before AE)



A E
FLAW LOCATOR
CENTER LAND

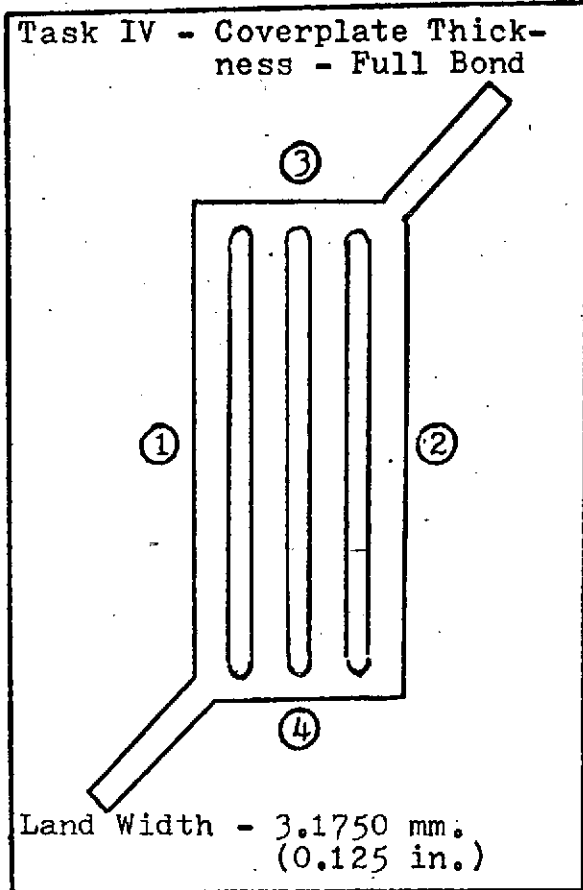


UT



Press. - 5.2×10^5 N/M^2
(75 PSI)

ELECTROFORMED PANEL NO. N-09 "A"



BASEPLATE

MATERIAL: Nickel 200

CENTER LAND FLATNESS VARIATION:
0.002 in. (0.0508 mm.)

THICKNESS:	MM.	INCHES
①	6.0655	0.2388
②	6.1087	0.2405
③	6.0630	0.2387
④	6.0909	0.2398

COVERPLATE

MATERIAL: Electroformed Nickel

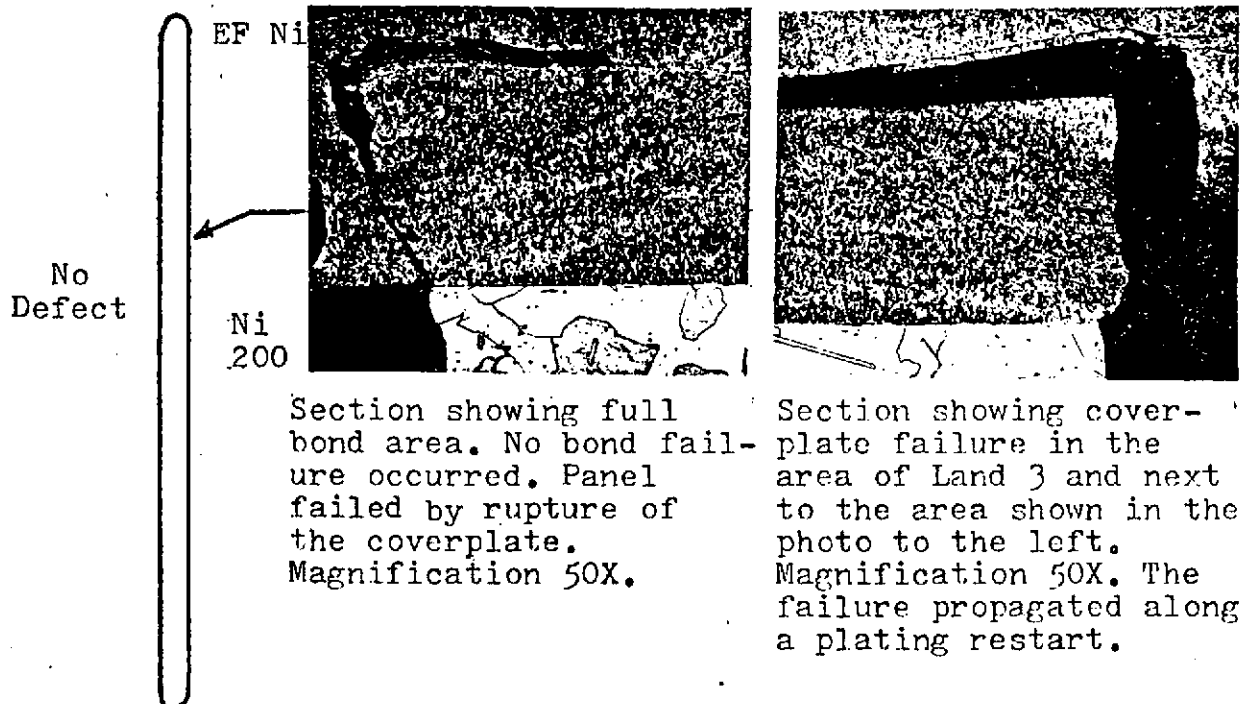
THICKNESS:	MM.	INCHES
①	0.7595	0.0299
②	0.7087	0.0279
③	0.7036	0.0277
④	0.6502	0.0256

PRESSURE REQUIRED TO FAIL BOND:

Panel failed at a pressure of
 $5.31 \times 10^7 \text{ N/m}^2$ (7,700 psi).

CENTER LAND DEFECT

METALLOGRAPHIC ANALYSIS:



Section showing full bond area. No bond failure occurred. Panel failed by rupture of the coverplate. Magnification 50X.

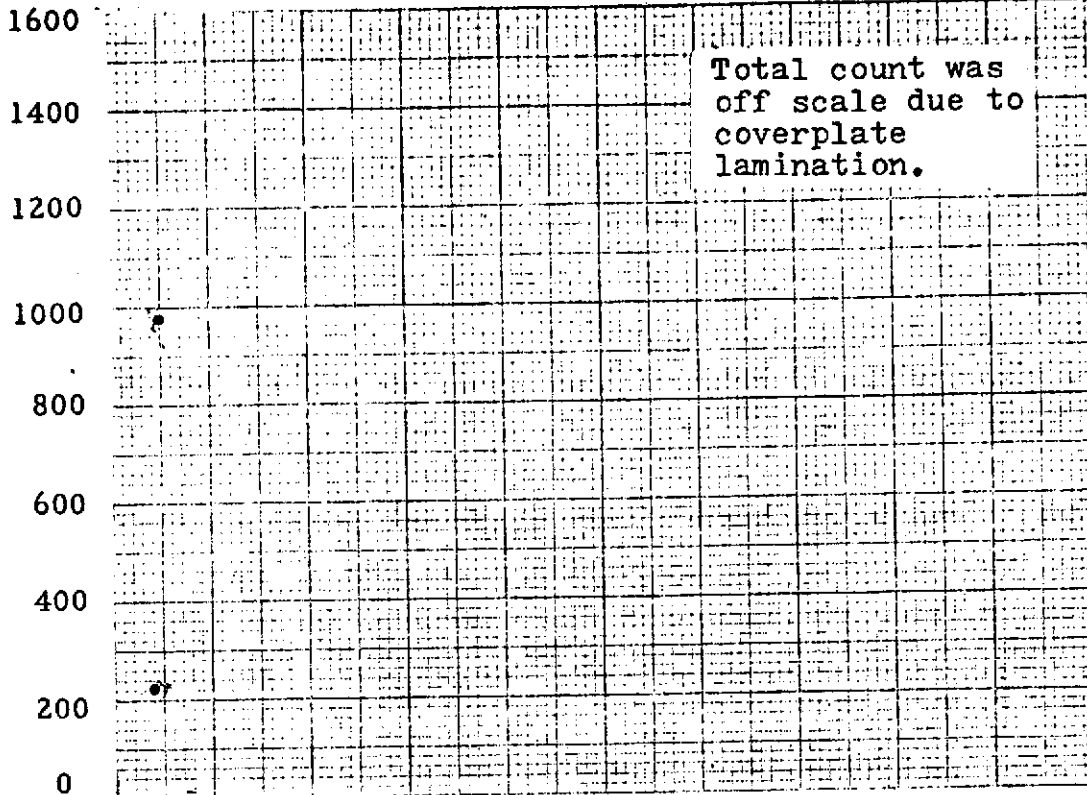
Section showing coverplate failure in the area of Land 3 and next to the area shown in the photo to the left. Magnification 50X. The failure propagated along a plating restart.

FIGURE C-8

Panel No. N-9"A'

Summation $\times 10^{-1}$

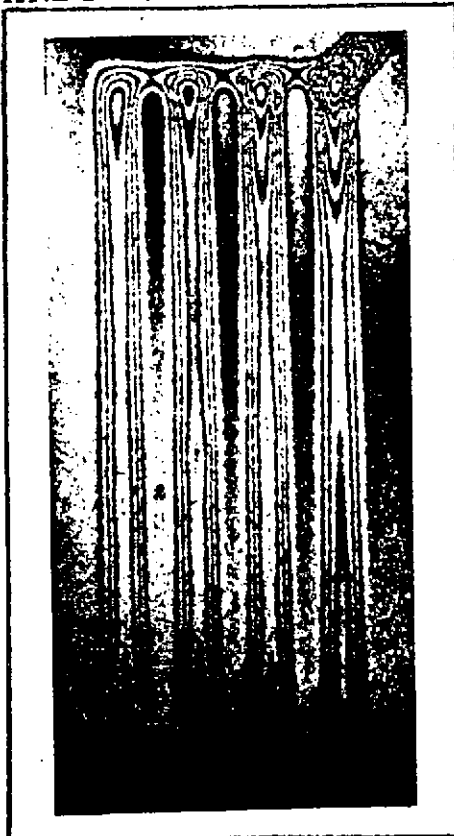
A E



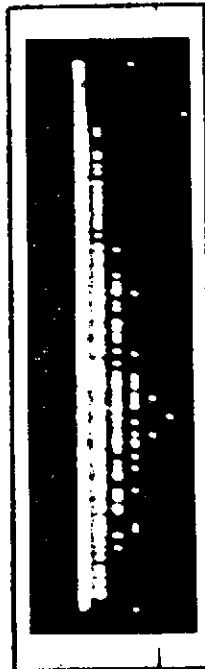
0 689 1378 2067 2756 3445 4134 4823 5512 6201 6890 $\times 10^4$
0 (1000) (2000) (3000) (4000) (5000) (6000) (7000) (8000) (9000) (10,000)

Pressure - N/M^2 (PSI)

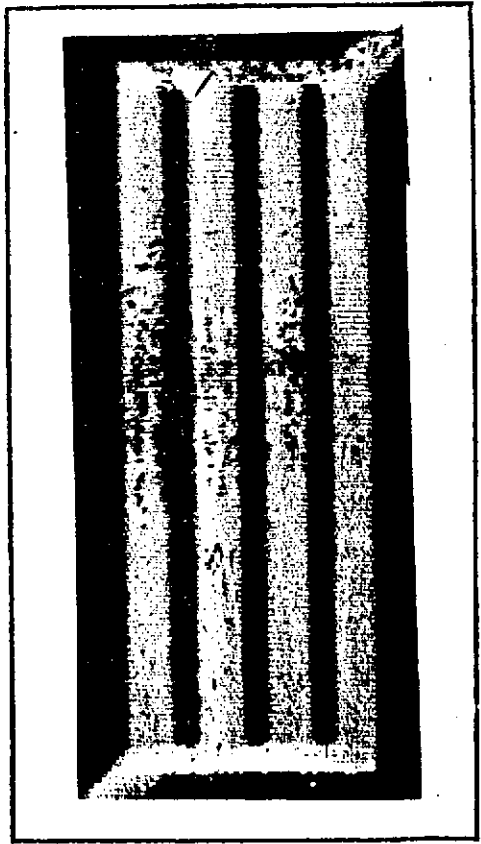
HNDT (Before AE)



AE
FLAW LOCATOR
CENTER LAND

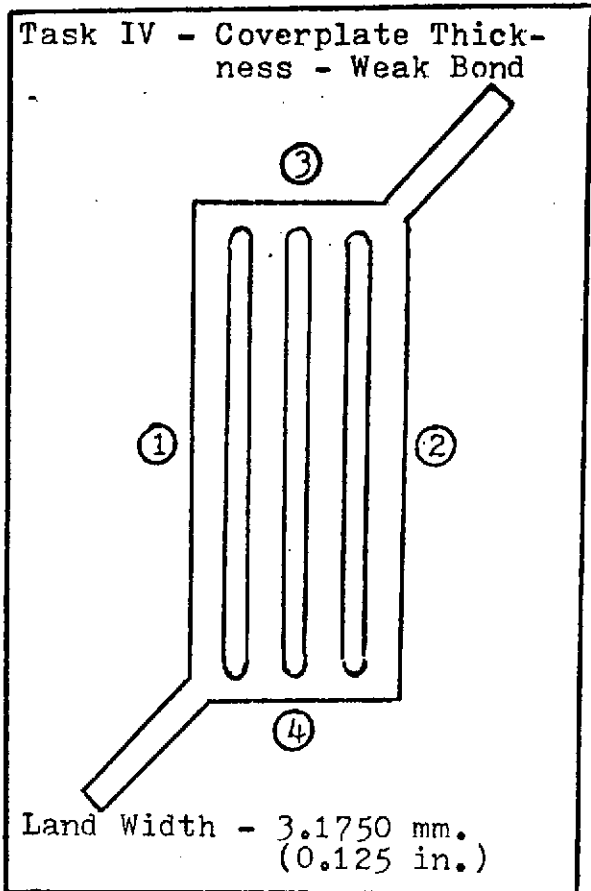


UT



Press. $13.8 \times 10^5 N/M^2$
(200 PSI)

ELECTROFORMED PANEL NO. N-33



BASEPLATE

MATERIAL: Nickel 200

CENTER LAND FLATNESS VARIATION:
0.004 in. (0.1016 mm.)

THICKNESS:	MM.	INCHES
①	6.2535	0.2462
②	6.2840	0.2474
③	6.2788	0.2472
④	6.2788	0.2472

COVERPLATE

MATERIAL: Electroformed Nickel

THICKNESS:	MM.	INCHES
①	0.7493	0.0295
②	0.6960	0.0274
③	0.6629	0.0261
④	0.7061	0.0278

PRESSURE REQUIRED TO FAIL BOND:

Bond failure occurred at a pressure of 4.62×10^7 N/m² (6,700 psi).
Bond failure was intermittent.

CENTER LAND DEFECT

METALLOGRAPHIC ANALYSIS:

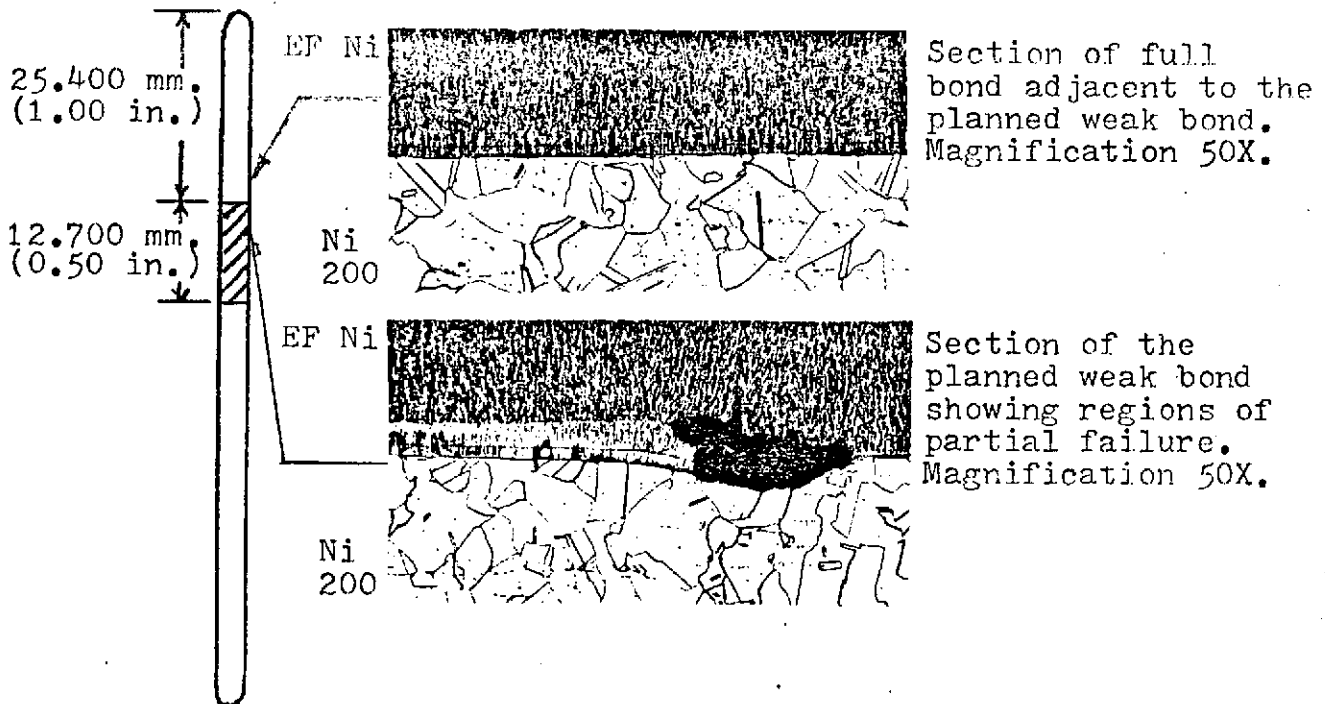
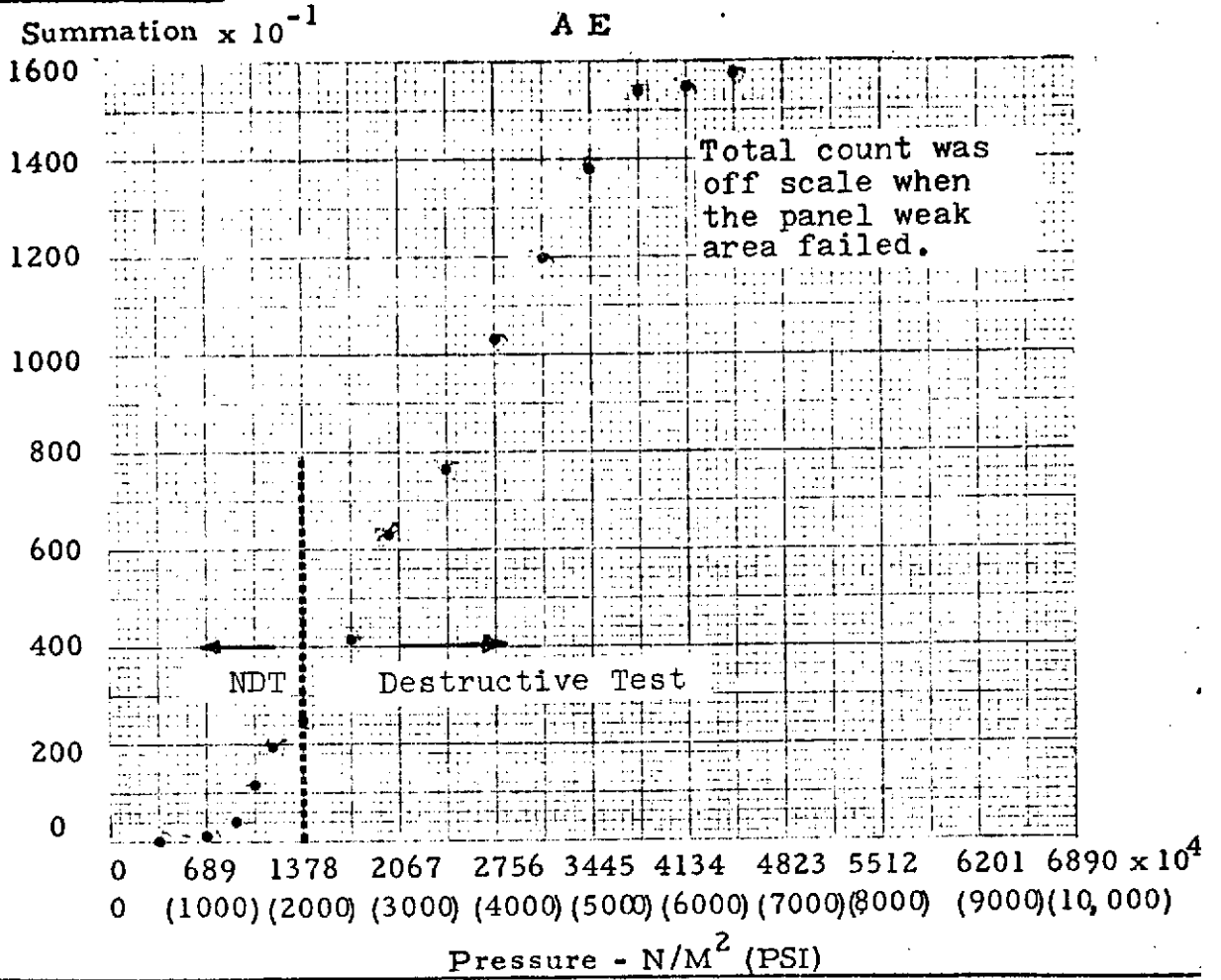


FIGURE C-9

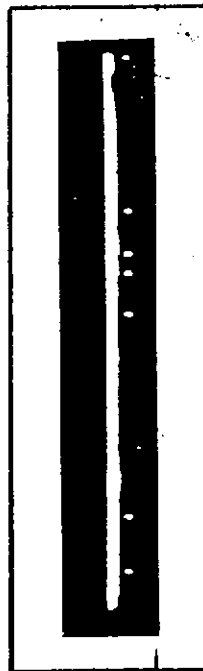
Panel No. N-33



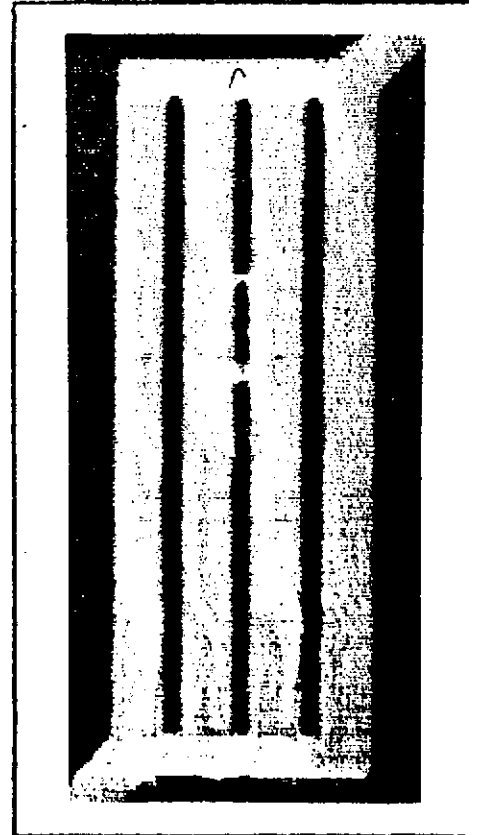
HNDT (Before AE)



AE
FLAW LOCATOR
CENTER LAND

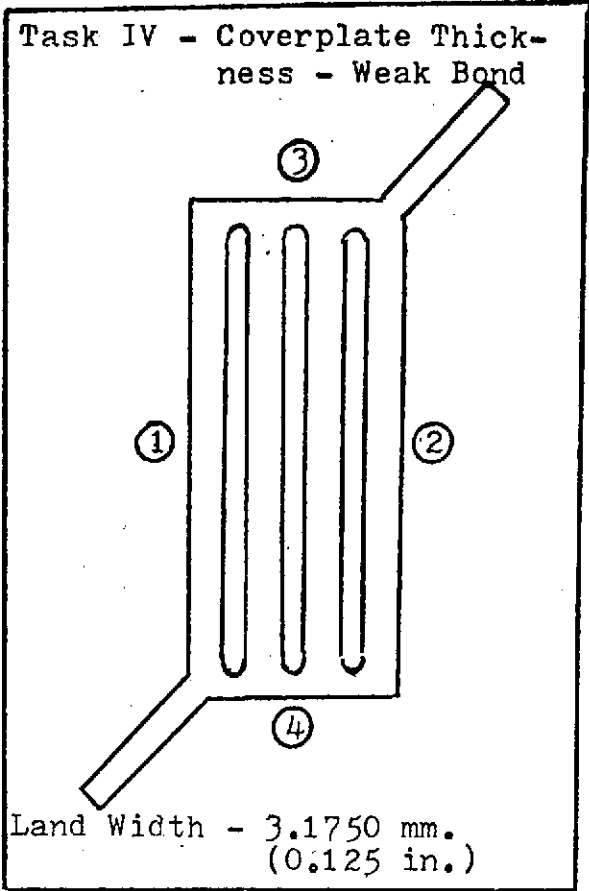


UT



Press. - 13.8×10^5 N/M²
(200 PSI)

ELECTROFORMED PANEL NO. N-34 "A"



BASEPLATE

MATERIAL: Nickel 200
CENTER LAND FLATNESS VARIATION:
0.002 in. (0.0508 mm.)

THICKNESS:	MM.	INCHES
①	6.1265	0.2412
②	6.1925	0.2438
③	6.1798	0.2433
④	6.1900	0.2437

COVERPLATE

MATERIAL: Electroformed Nickel

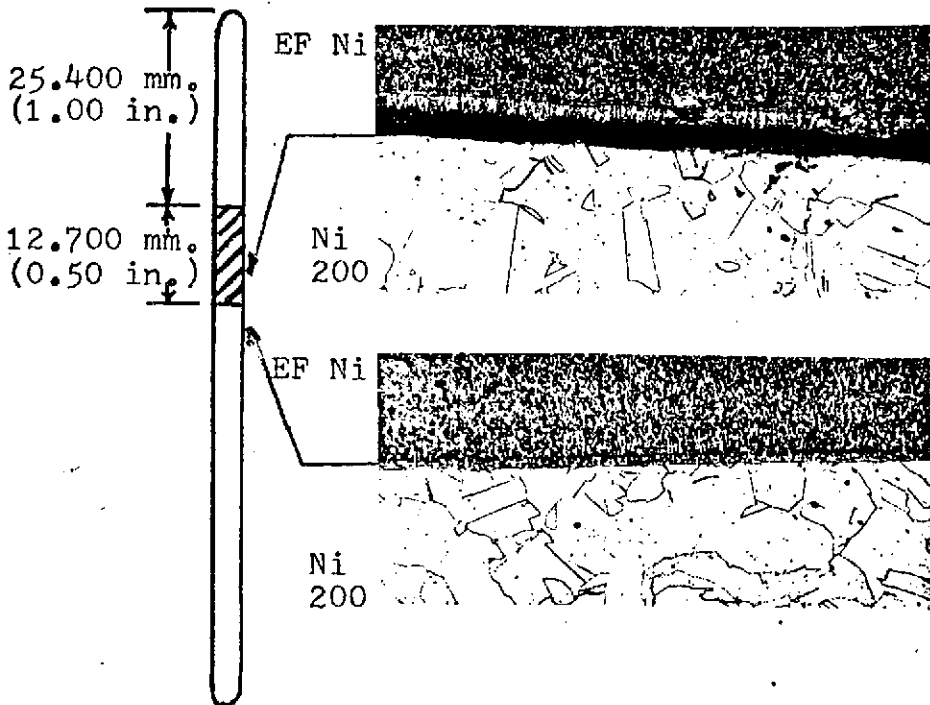
THICKNESS:	MM.	INCHES
①	0.7569	0.0298
②	0.7188	0.0283
③	0.6502	0.0256
④	0.7010	0.0276

PRESSURE REQUIRED TO FAIL BOND:

Bond failed at a pressure of
 $2.42 \times 10^7 \text{ N/m}^2$ (3,500 psi).

CENTER LAND DEFECT

METALLOGRAPHIC ANALYSIS:



Section showing planned weak bond failure. Bond was quite weak as evident from the lack of significant metal disturbance. Magnification 50X.

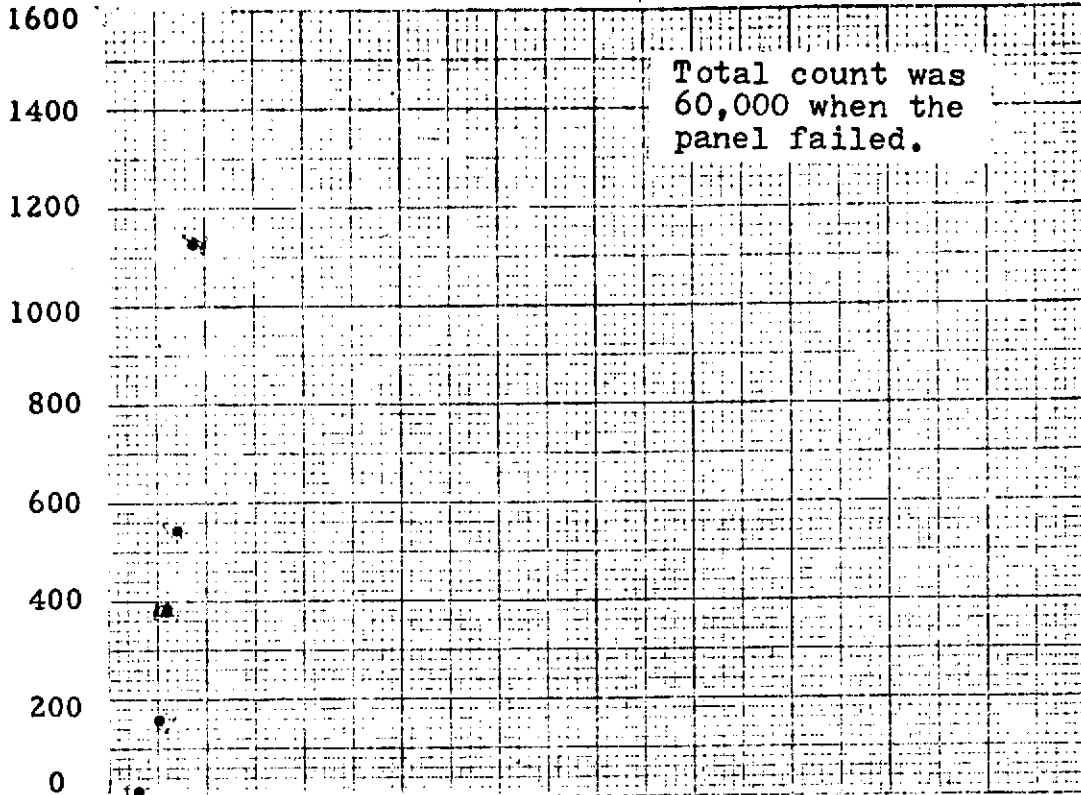
Planned full bond region near the weak bond above. No failure evident. Magnification 50X.

FIGURE C-10

Panel No. N-34"A"

Summation $\times 10^{-1}$

A E



0 689 1378 2067 2756 3445 4134 4823 5512 6201 6890 $\times 10^4$
0 (1000) (2000) (3000) (4000) (5000) (6000) (7000) (8000) (9000) (10,000)

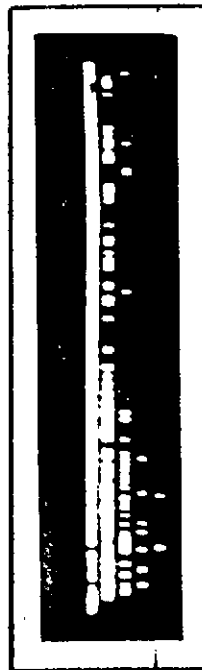
Pressure - N/M^2 (PSI)

HNDT (Before AE)

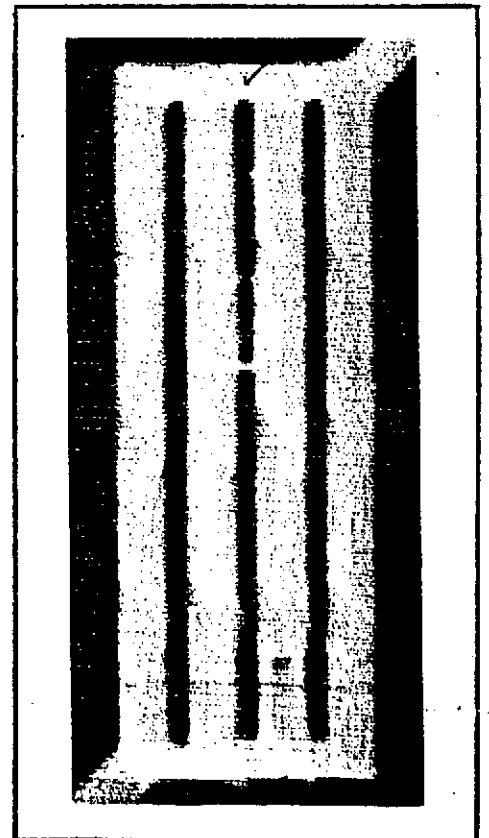


Press. $6.9 \times 10^5 N/M^2$
(100 PSI)

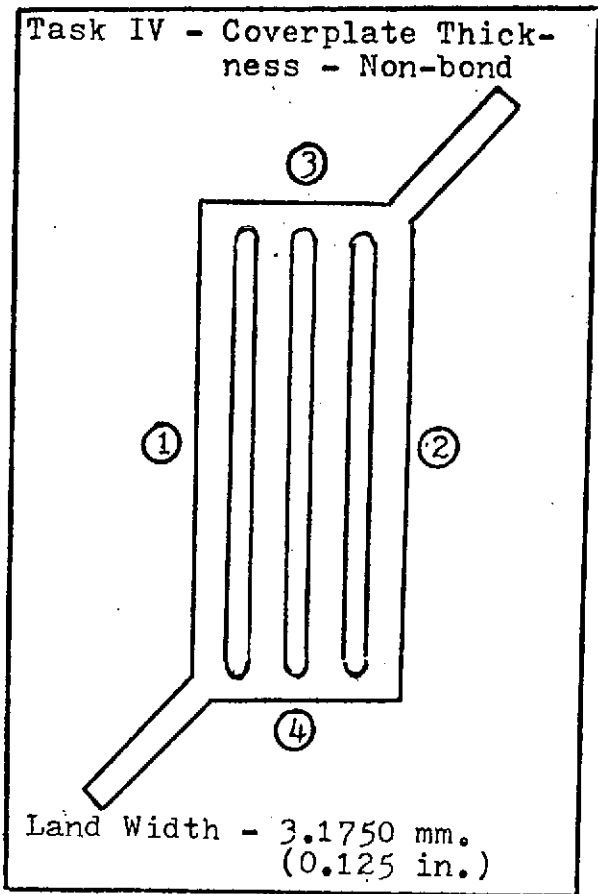
AE
FLAW LOCATOR
CENTER LAND



UT



ELECTROFORMED PANEL NO. N-40 "A"



BASEPLATE

MATERIAL: Nickel 200
CENTER LAND FLATNESS VARIATION:
0.0085 in. (0.2159 mm.)

THICKNESS:	MM.	INCHES
①	5.9665	0.2349
②	5.9639	0.2348
③	6.0884	0.2397
④	6.0401	0.2378

COVERPLATE

MATERIAL: Electroformed Nickel

THICKNESS:	MM.	INCHES
①	0.7518	0.0296
②	0.7341	0.0289
③	0.6248	0.0246
④	0.7442	0.0293

PRESSURE REQUIRED TO FAIL BOND:

Panel failed at a pressure of
 $2.42 \times 10^7 \text{ N/m}^2$ (3,500 psi).

CENTER LAND DEFECT

METALLOGRAPHIC ANALYSIS:

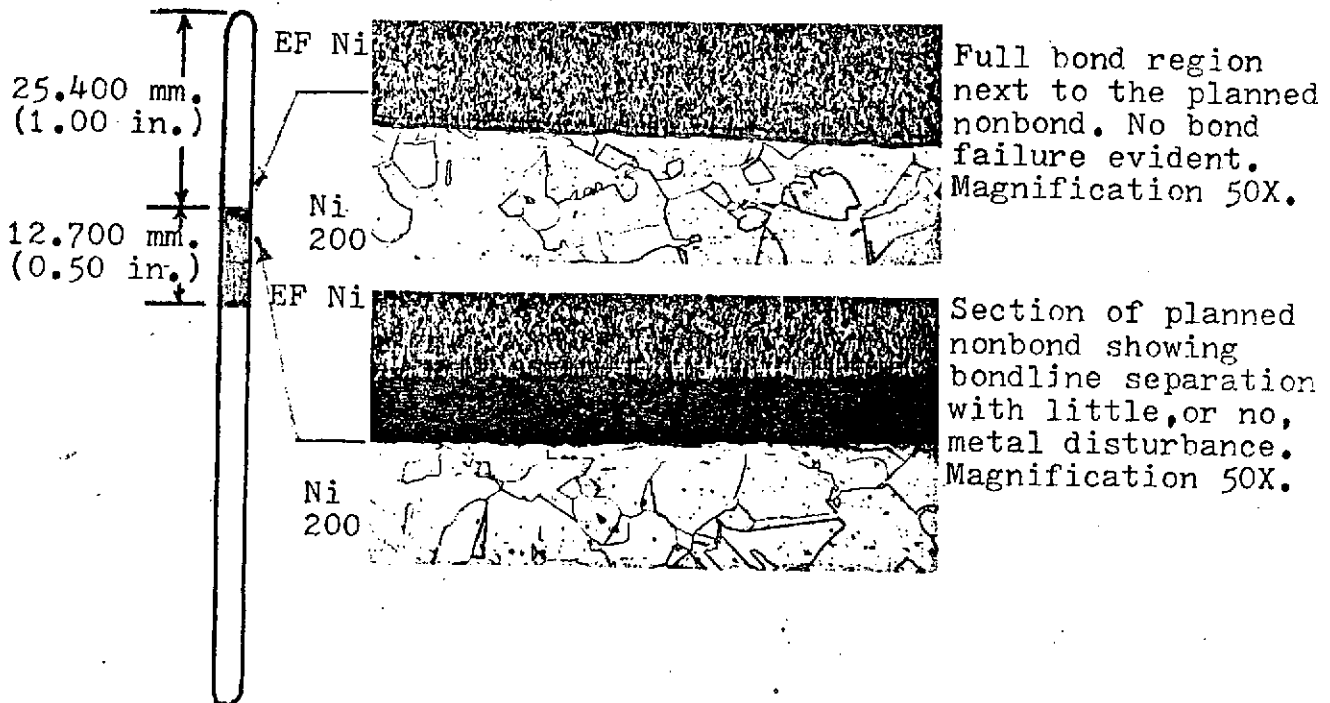
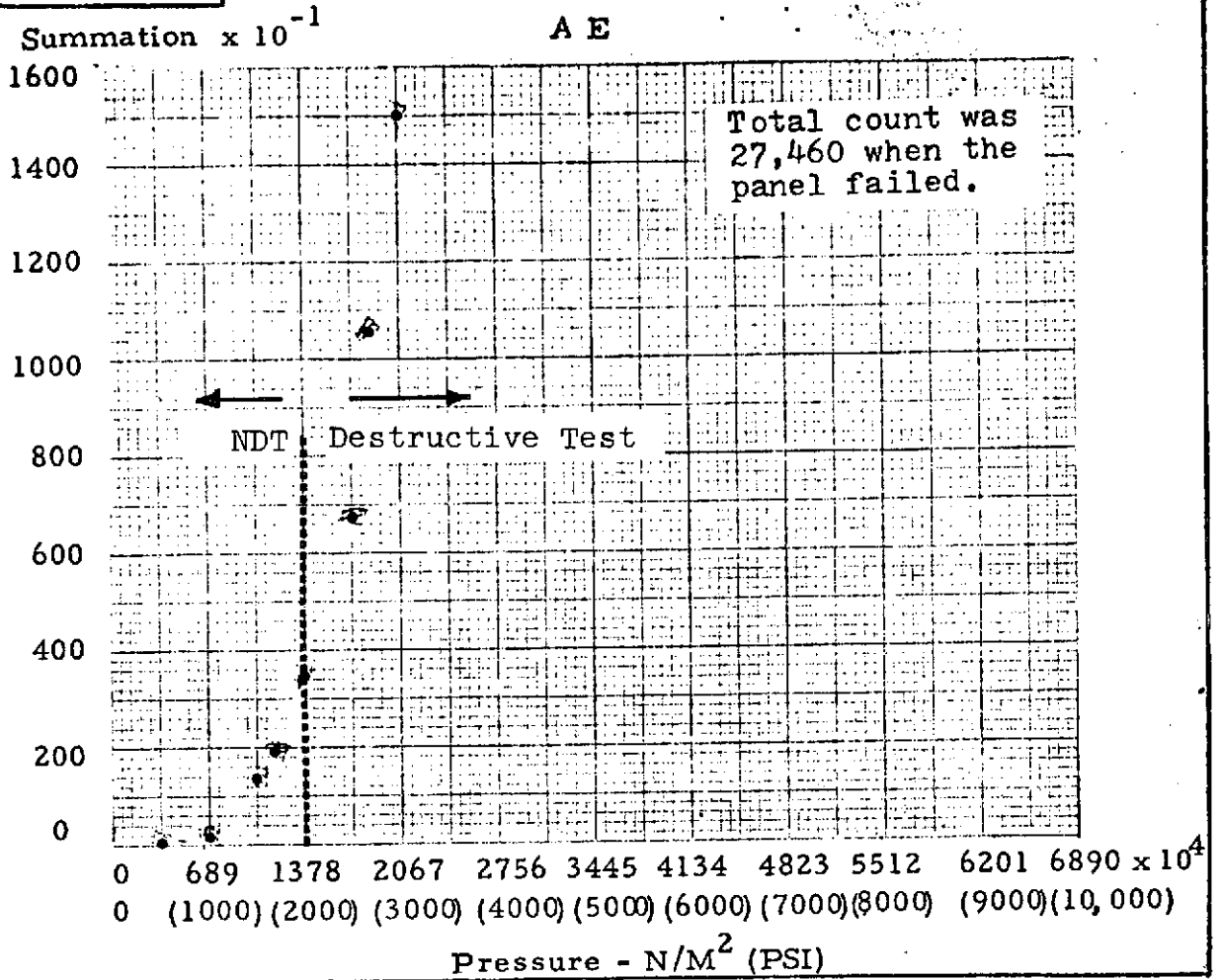
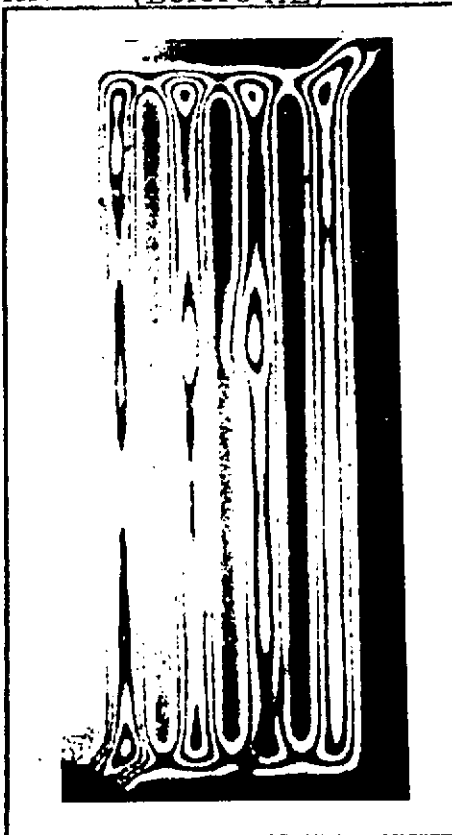


FIGURE C-11

Panel No. N-40'A''



HNDT (Before AE)

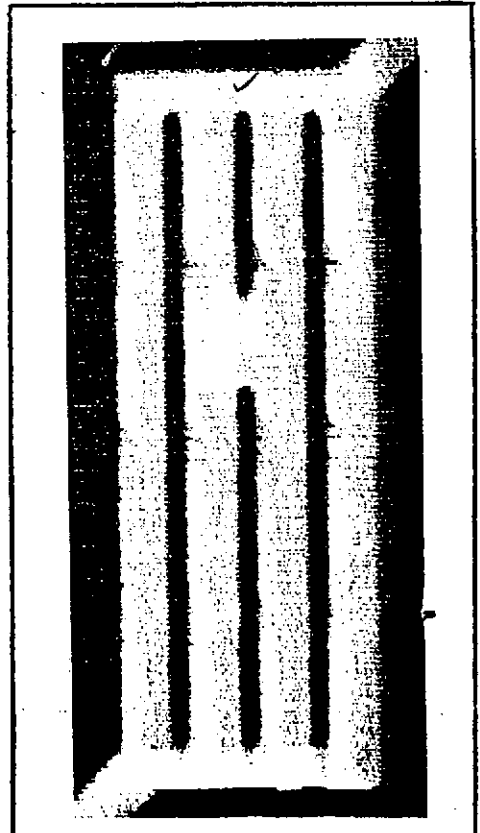


Press. 4.1×10^5 N/M^2
(60 PSI)

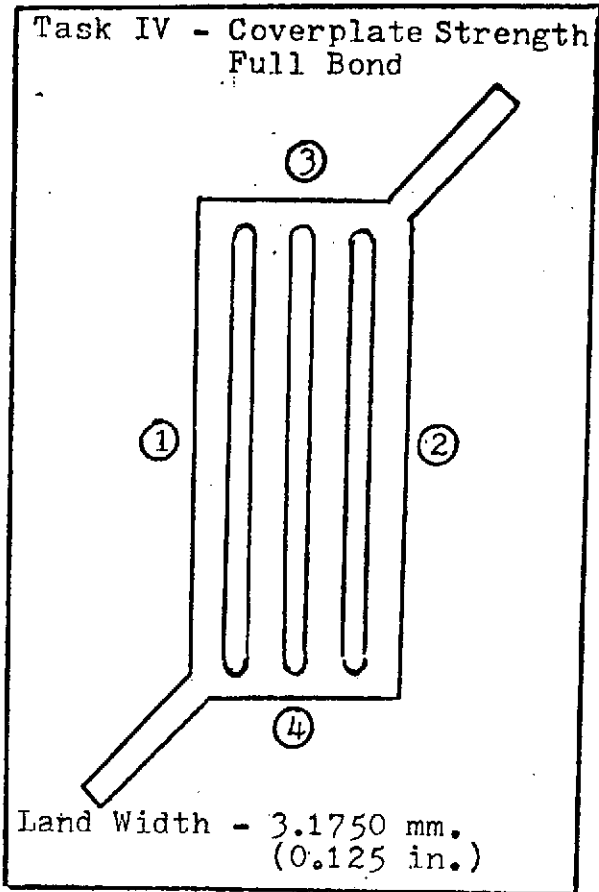
AE
FLAW LOCATOR
CENTER LAND



UT



ELECTROFORMED PANEL NO. N-21



BASEPLATE

MATERIAL: Nickel 200

CENTER LAND FLATNESS VARIATION:
0.001 in. (0.0254 mm.)

THICKNESS:	MM.	INCHES
①	6.2499	0.2459
②	6.2078	0.2444
③	6.2205	0.2449
④	6.2001	0.2441

COVERPLATE

MATERIAL: Electroformed Nickel

THICKNESS:	MM.	INCHES
①	0.9119	0.0359
②	0.9804	0.0386
③	0.9881	0.0389
④	1.0008	0.0394

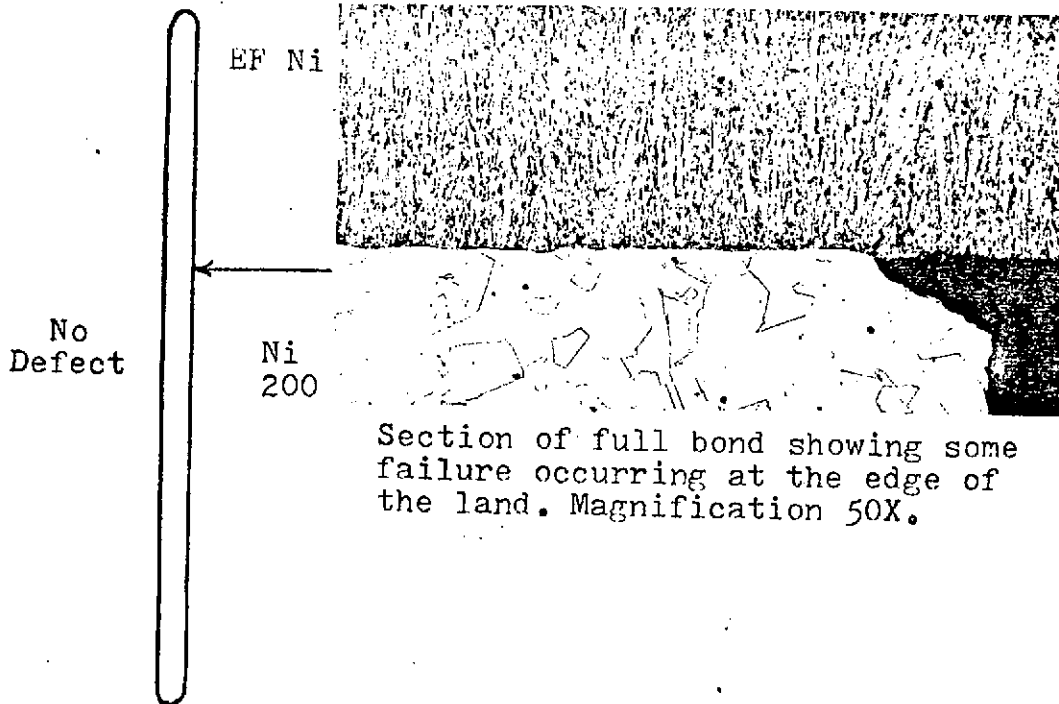
PRESSURE REQUIRED TO FAIL BOND:

Panel failed at a pressure of
 5.52×10^7 N/m² (8,000 psi).

Note that lower strength EF Nickel
was used on this panel.

CENTER LAND DEFECT

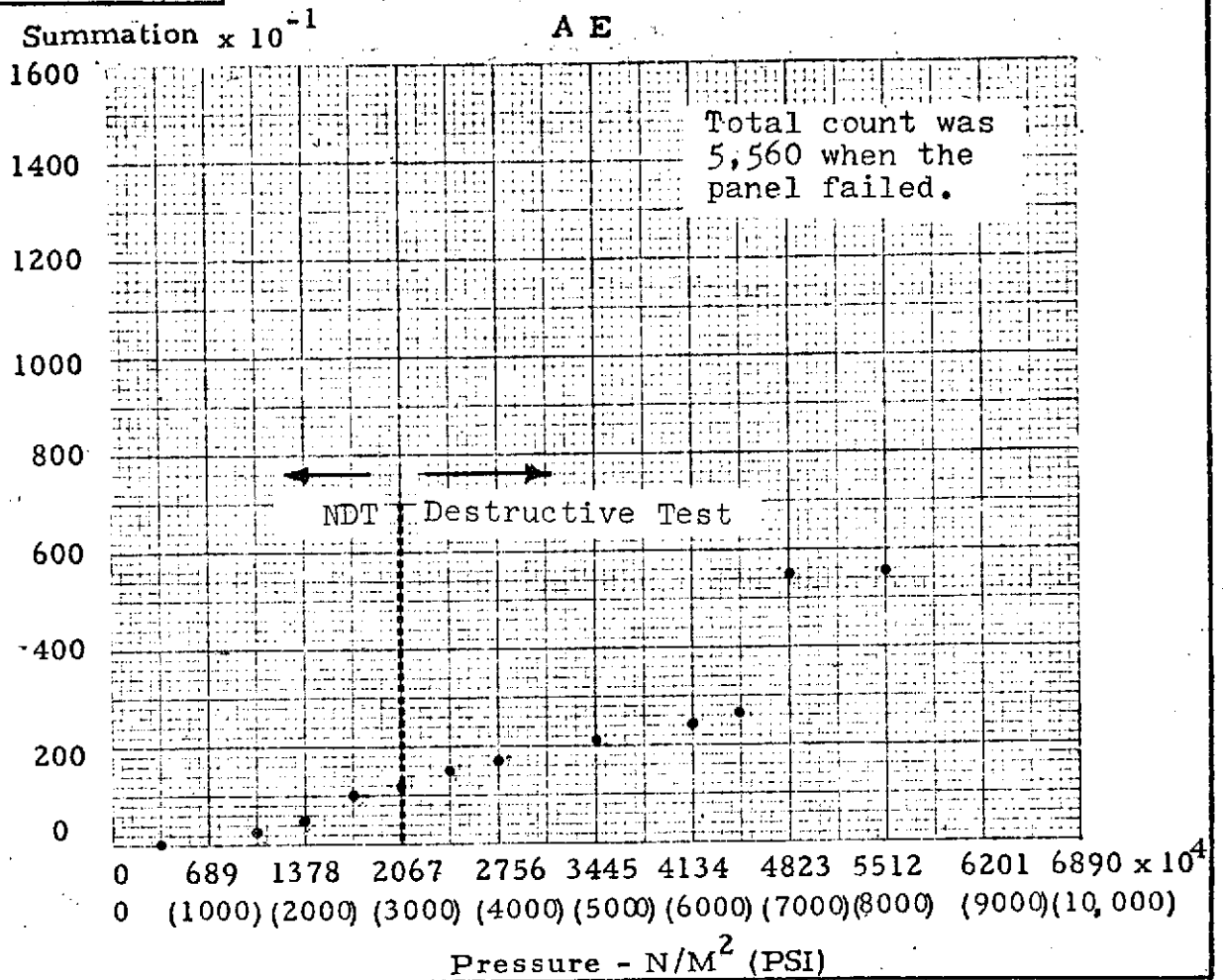
METALLOGRAPHIC ANALYSIS:



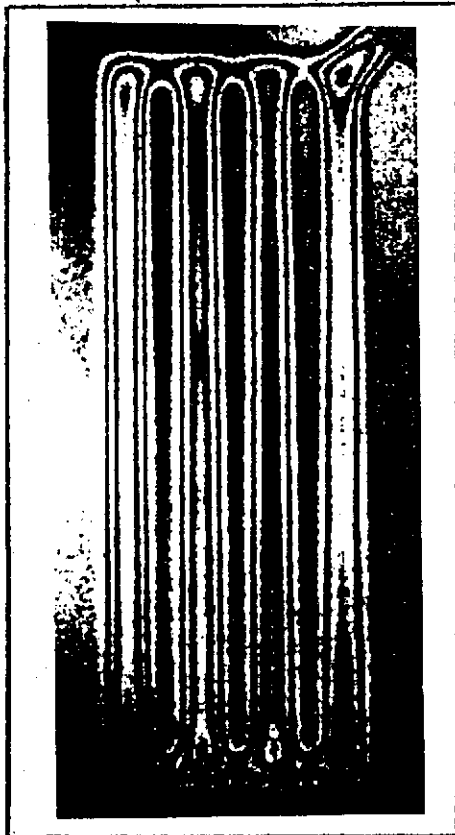
Section of full bond showing some
failure occurring at the edge of
the land. Magnification 50X.

FIGURE C-12

Panel No. N-21



HNDT (Before AE)

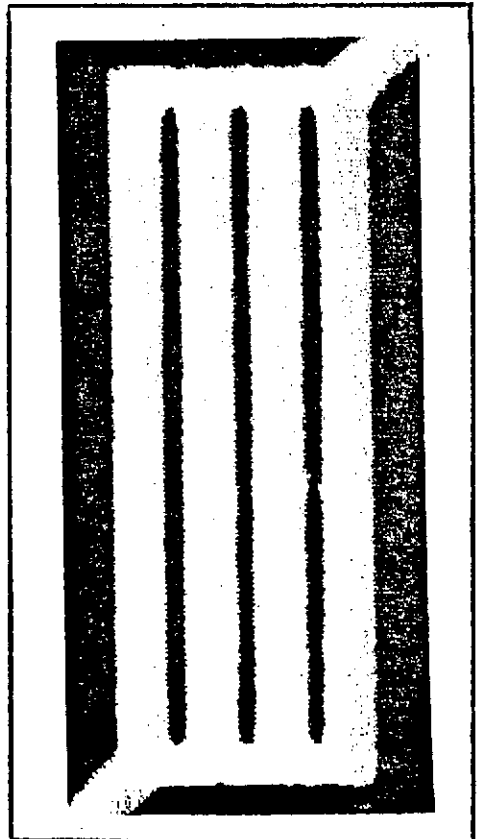


Press. - $13.8 \times 10^5 N/M^2$
(200 PSI)

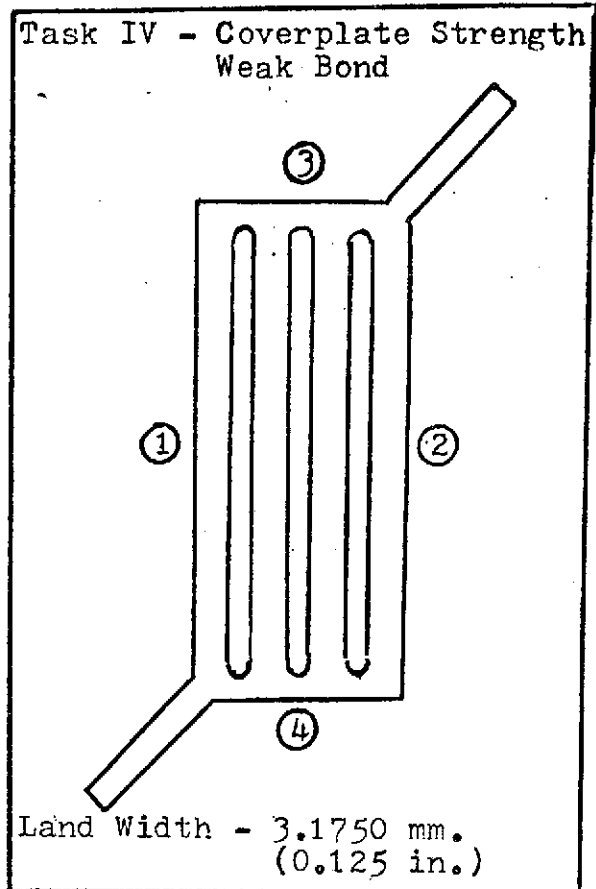
AE
FLAW LOCATOR
CENTER LAND



UT



ELECTROFORMED PANEL NO. N-36



BASEPLATE

MATERIAL: Nickel 200

CENTER LAND FLATNESS VARIATION:
0.004 in. (0.1016 mm.)

THICKNESS:	MM.	INCHES
①	6.2052	0.2443
②	6.1951	0.2439
③	6.2332	0.2454
④	6.2001	0.2441

COVERPLATE

MATERIAL: Electroformed Nickel

THICKNESS:	MM.	INCHES
①	0.9525	0.0375
②	0.9449	0.0372
③	0.9093	0.0358
④	0.9627	0.0379

PRESSURE REQUIRED TO FAIL BOND:

Bond failed at a pressure of
 2.76×10^7 N/m² (4,000 psi).

CENTER LAND DEFECT

METALLOGRAPHIC ANALYSIS:

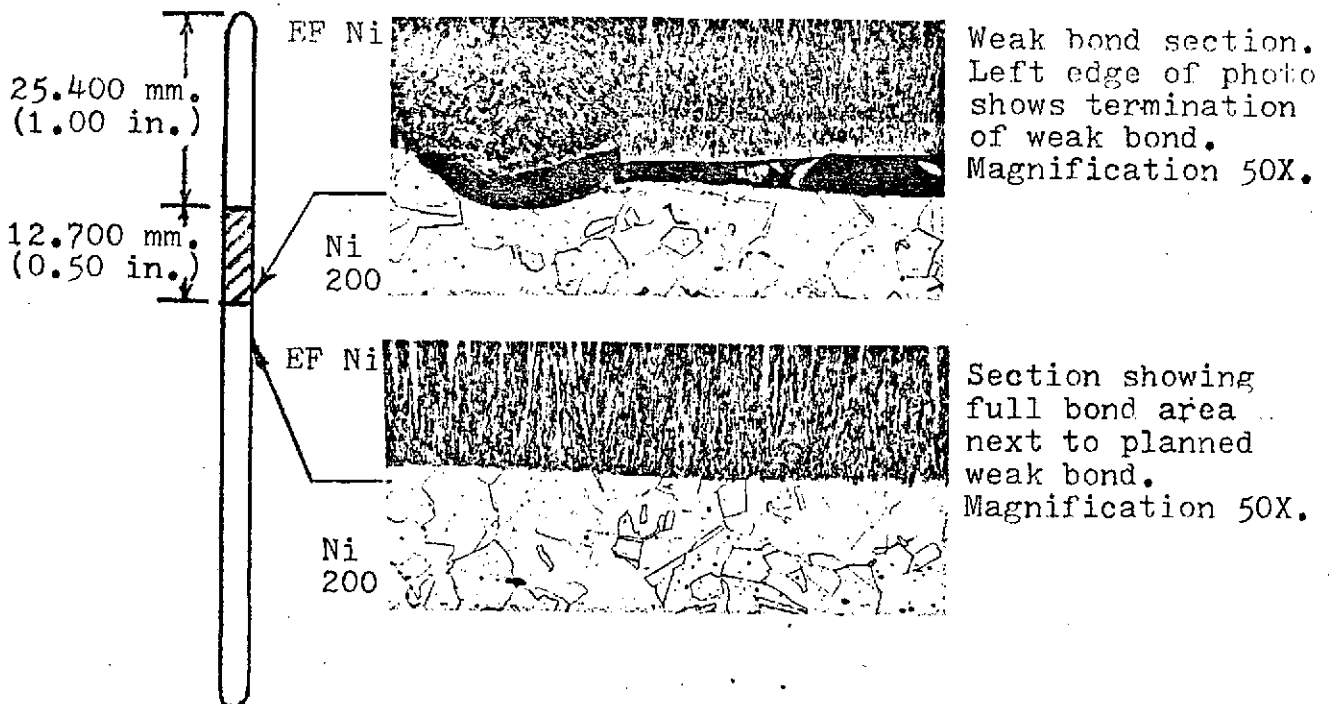
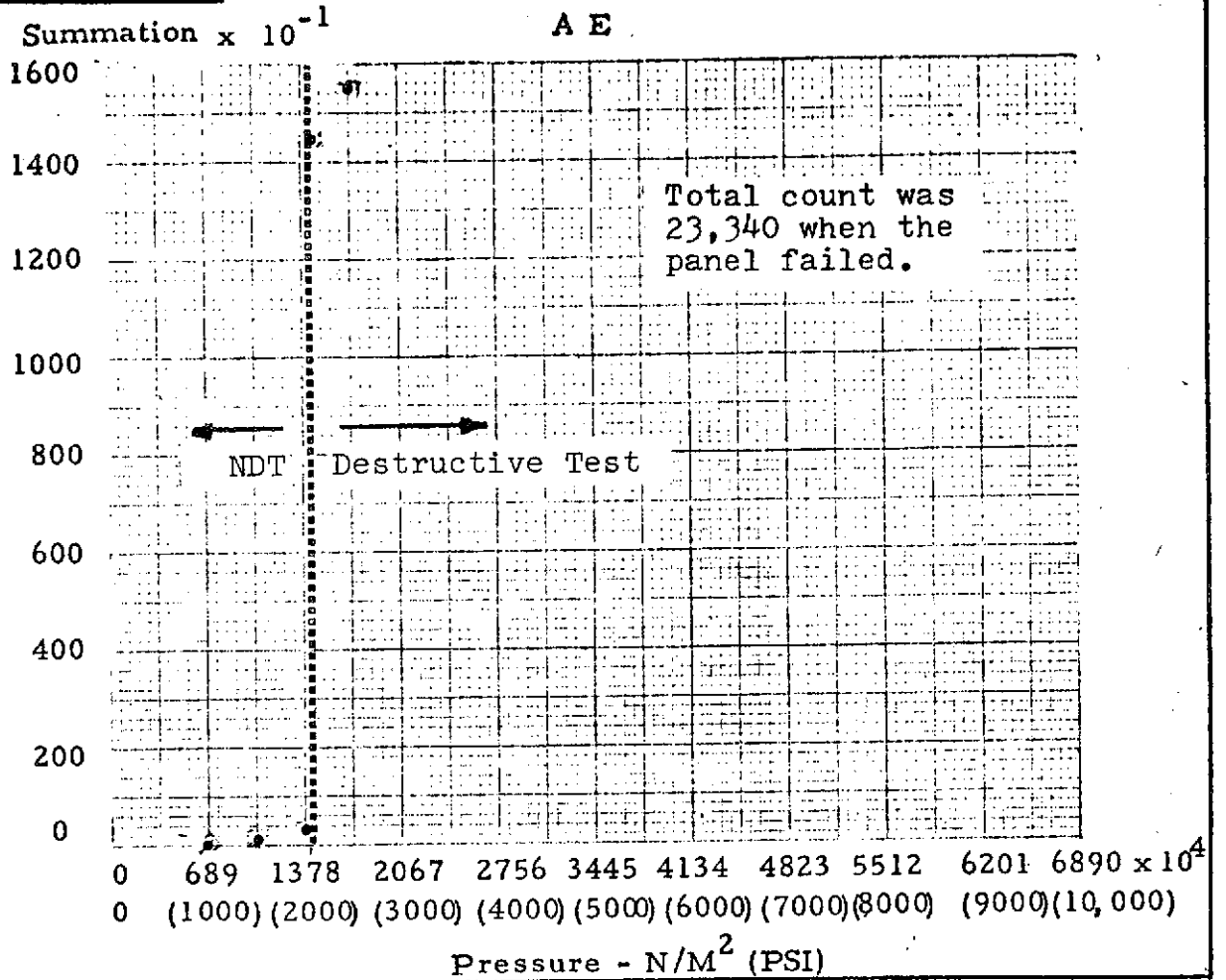


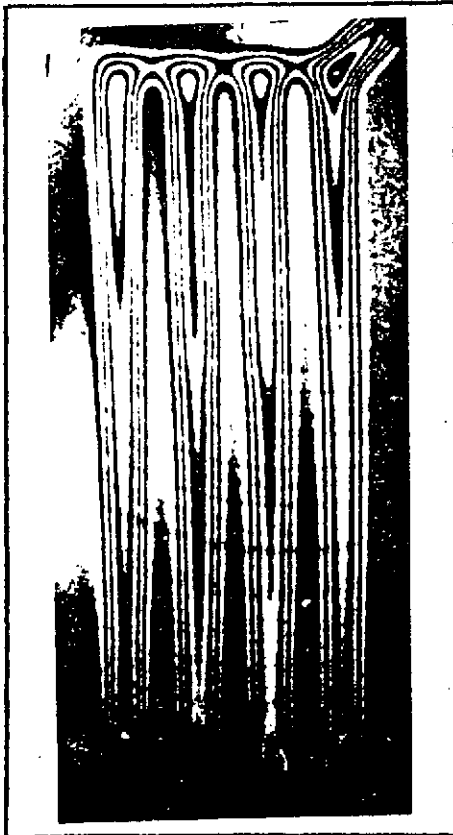
FIGURE C-13

C-2

Panel No. N-36

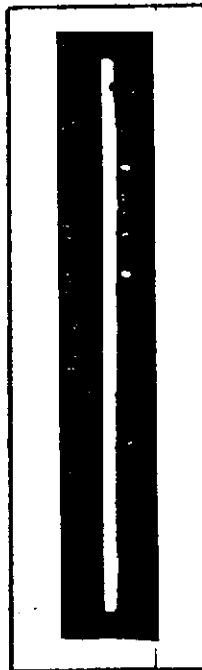


HNDT (After AE)

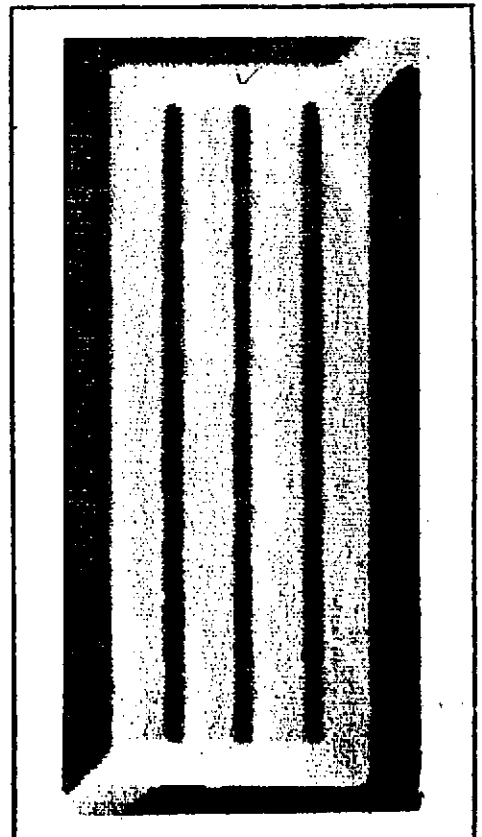


Press. 20.7×10^5 N/M^2
(300 PSI)

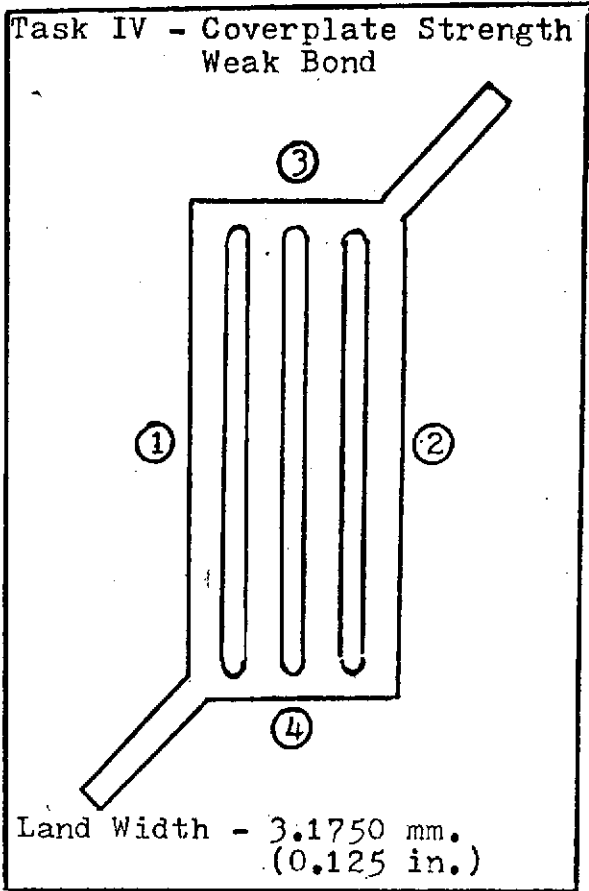
AE
FLAW LOCATOR
CENTER LAND



UT



ELECTROFORMED PANEL NO. N-37



BASEPLATE

MATERIAL: Nickel 200

CENTER LAND FLATNESS VARIATION:
0.006 in. (0.1524 mm.)

THICKNESS:	MM.	INCHES
①	6.1798	0.2433
②	6.2052	0.2443
③	6.1925	0.2438
④	6.2027	0.2442

COVERPLATE

MATERIAL: Electroformed Nickel

THICKNESS:	MM.	INCHES
①	0.9017	0.0355
②	0.9017	0.0355
③	1.0135	0.0399
④	0.9398	0.0370

PRESSURE REQUIRED TO FAIL BOND:

Bond failed at a pressure of
 $2.21 \times 10^7 \text{ N/m}^2$ (3,200 psi)

CENTER LAND DEFECT

METALLOGRAPHIC ANALYSIS:

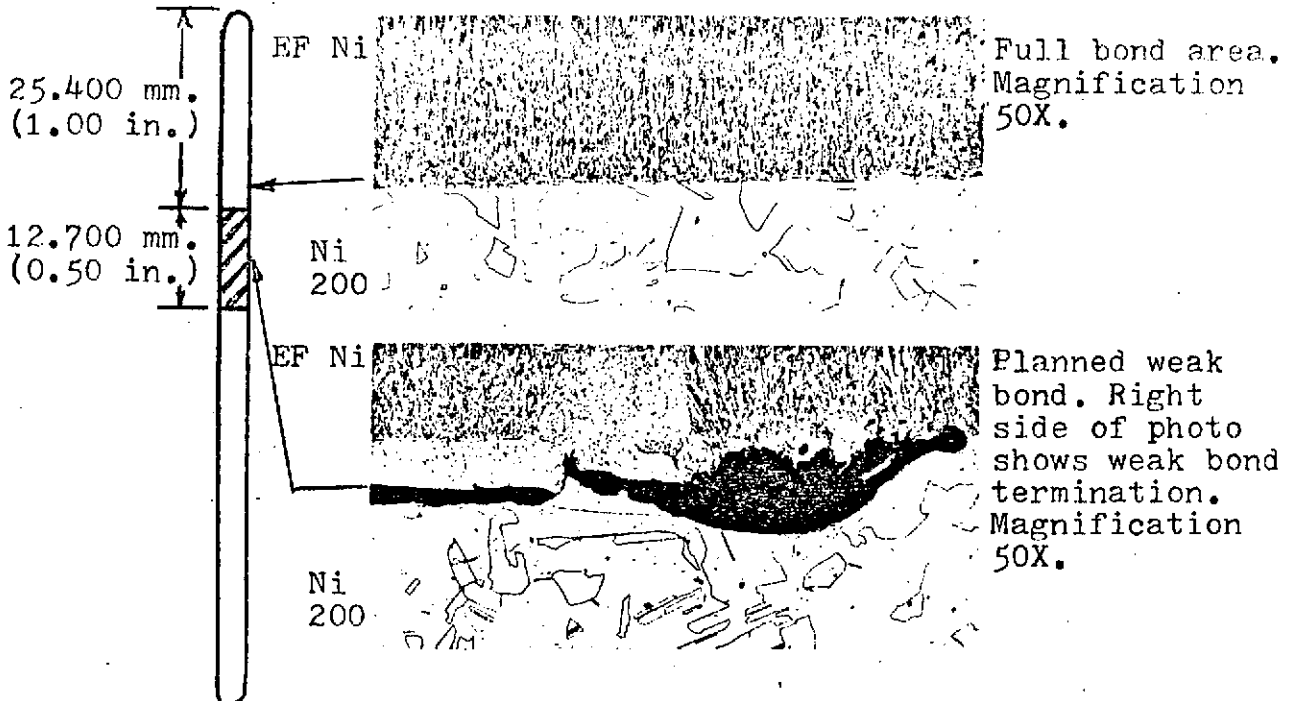
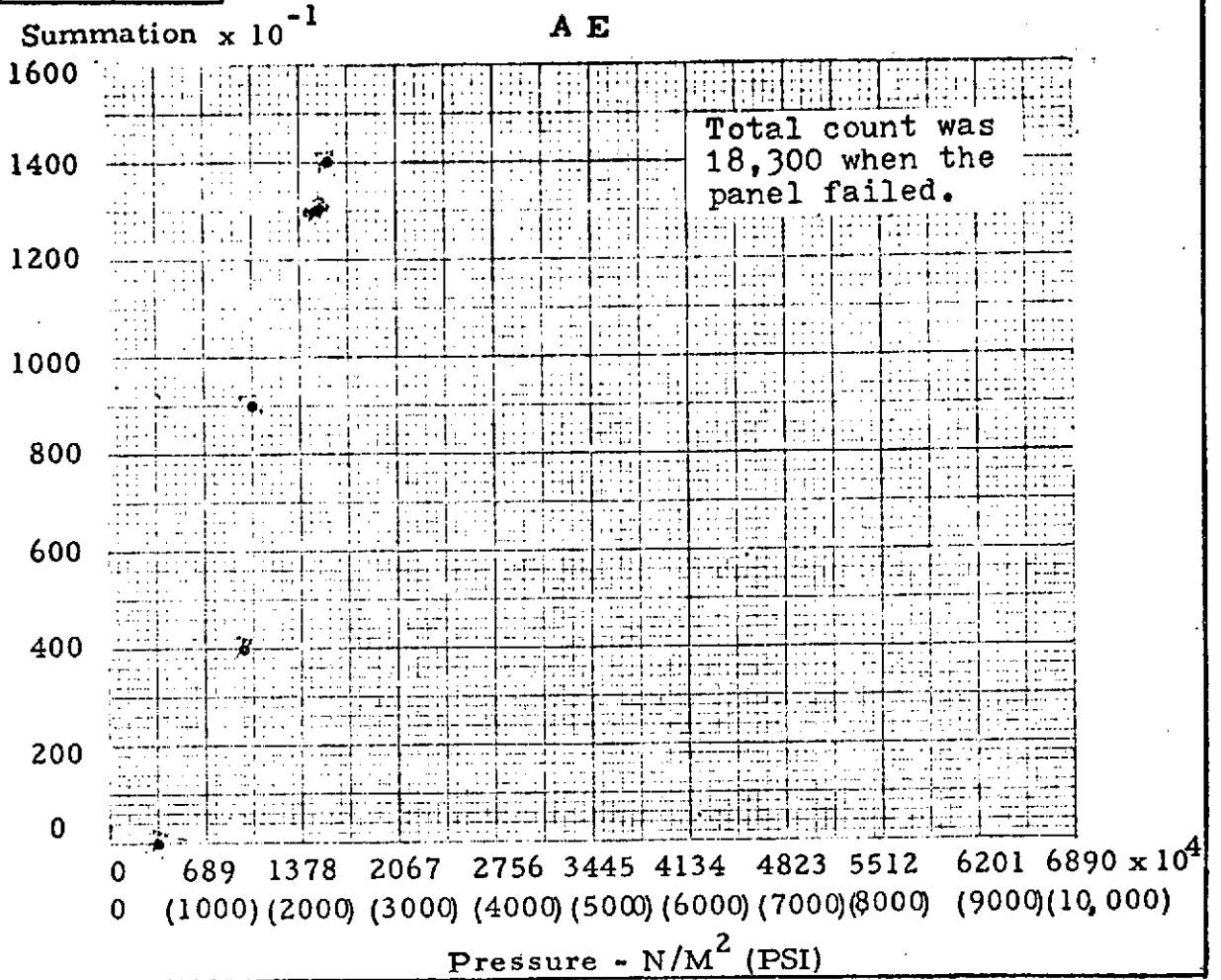
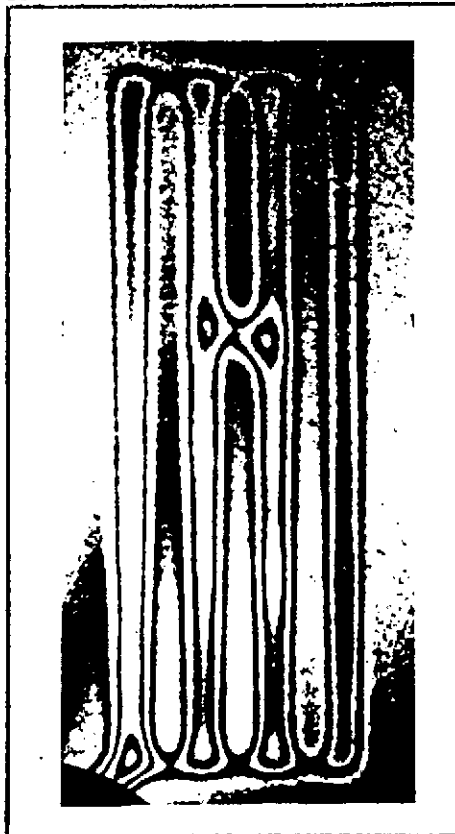


FIGURE C-14

Panel No. N-37

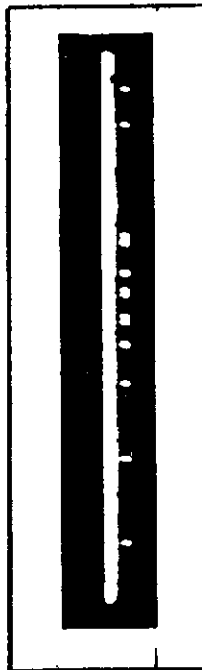


HNDT (After AE)

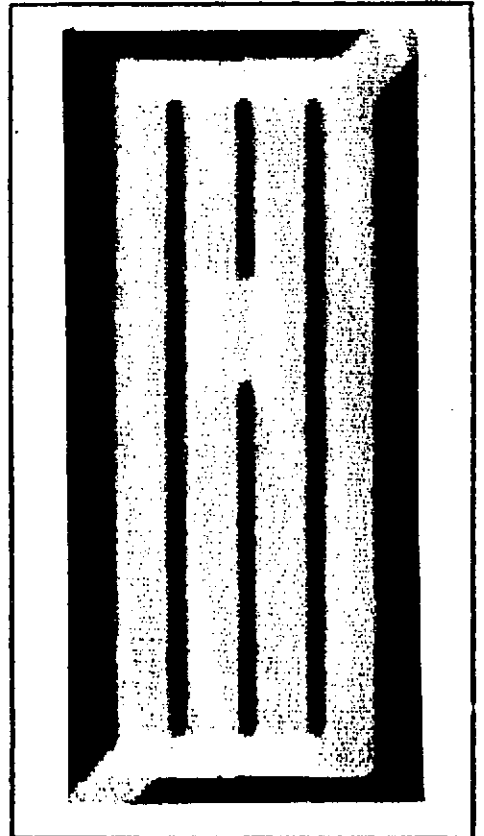


Press. 6.9×10^5 N/M^2
(100 PSI)

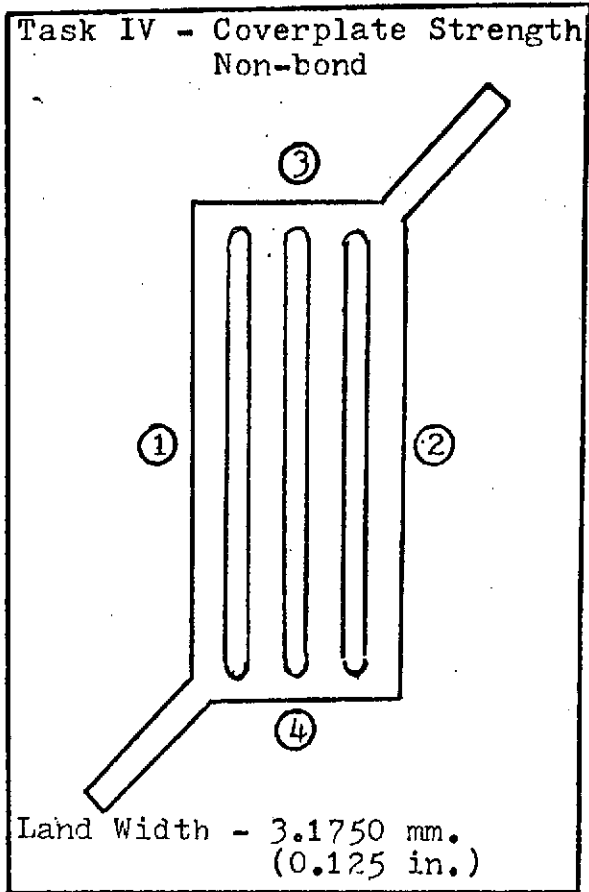
AE
FLAW LOCATOR
CENTER LAND



UT



ELECTROFORMED PANEL NO. N-41 "A"



BASEPLATE

MATERIAL: Nickel 200

CENTER LAND FLATNESS VARIATION:
0.008 in. (0.2032 mm.)

THICKNESS:	MM.	INCHES
①	5.8217	0.2292
②	5.8801	0.2315
③	5.9639	0.2348
④	5.9436	0.2340

COVERPLATE

MATERIAL: Electroformed Nickel

THICKNESS:	MM.	INCHES
①	0.9068	0.0357
②	0.8941	0.0352
③	0.8763	0.0345
④	0.8712	0.0343

PRESSURE REQUIRED TO FAIL BOND:

Panel failed at a pressure of
 1.59×10^7 N/m² (2,300 psi).

CENTER LAND DEFECT

METALLOGRAPHIC ANALYSIS:

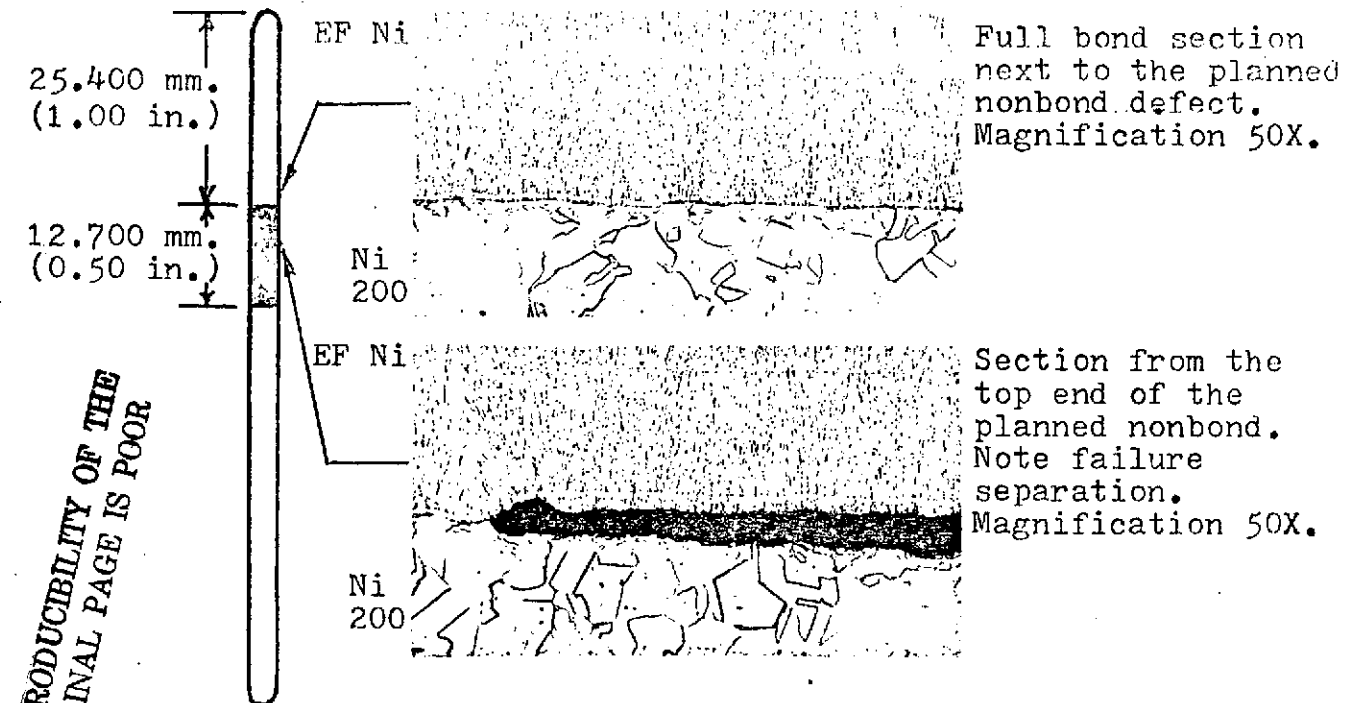
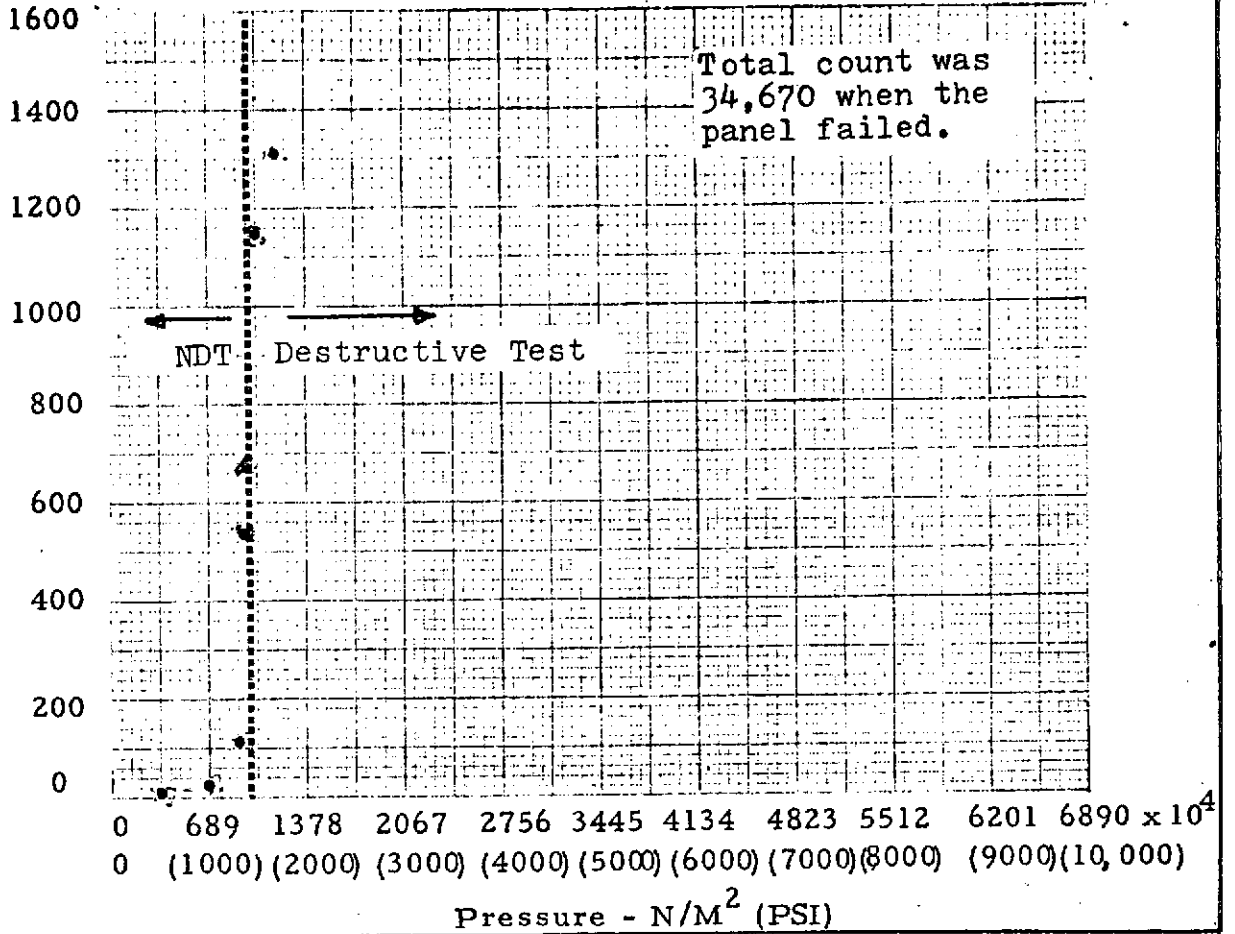


FIGURE C-15

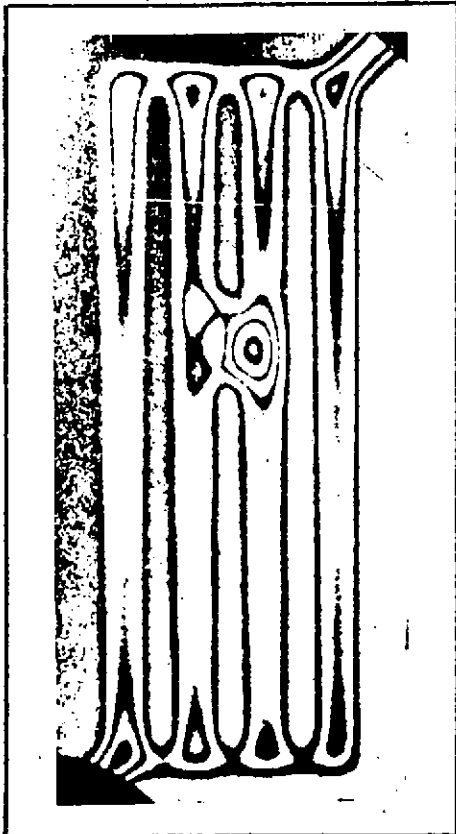
Panel No. N-41"A"

Summation $\times 10^{-1}$

A E

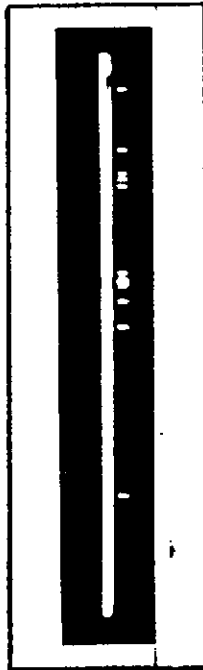


HNDT (Before AE)

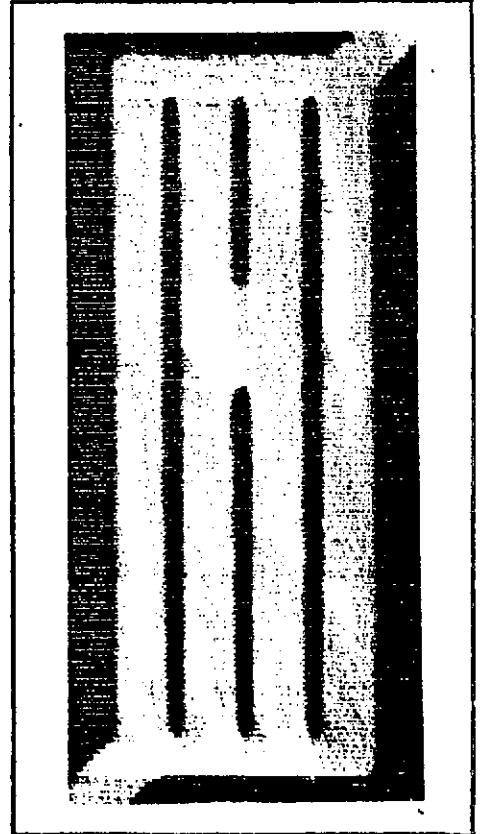


Press. $6.9 \times 10^5 N/M^2$
(100 PSI)

AE
FLAW LOCATOR
CENTER LAND

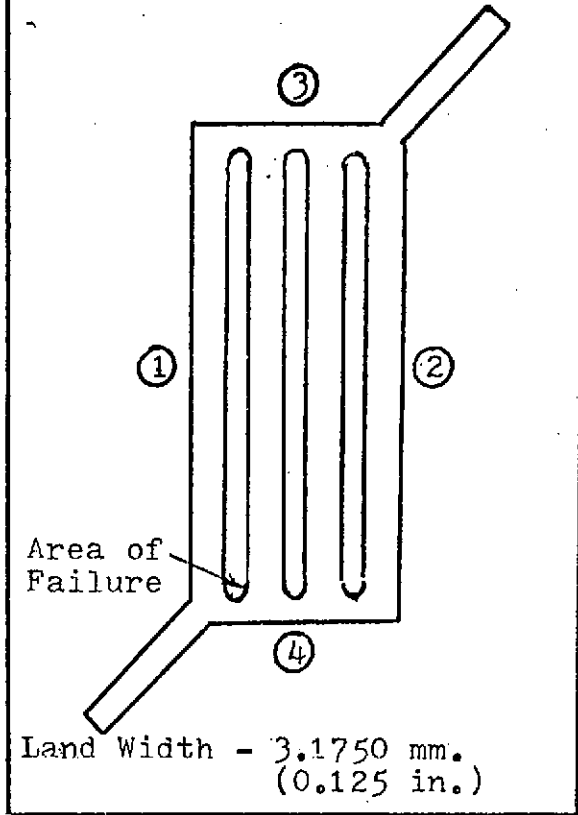


UT



ELECTROFORMED PANEL NO. N-13

Task IV - Surface Flatness
Full Bond



BASEPLATE

MATERIAL: Nickel 200

CENTER LAND FLATNESS VARIATION:
0.006 in. (0.1524 mm.)

THICKNESS:	MM.	INCHES
①	6.2230	0.2450
②	6.2306	0.2453
③	6.2586	0.2464
④	6.2763	0.2471

COVERPLATE

MATERIAL: Electroformed Nickel

THICKNESS:	MM.	INCHES
①	0.7874	0.0310
②	0.7442	0.0293
③	0.9017	0.0355
④	0.6325	0.0249

PRESSURE REQUIRED TO FAIL BOND:

Panel failed at a pressure of
 $5.11 \times 10^7 \text{ N/m}^2$ (7,400 psi).

CENTER LAND DEFECT

METALLOGRAPHIC ANALYSIS:

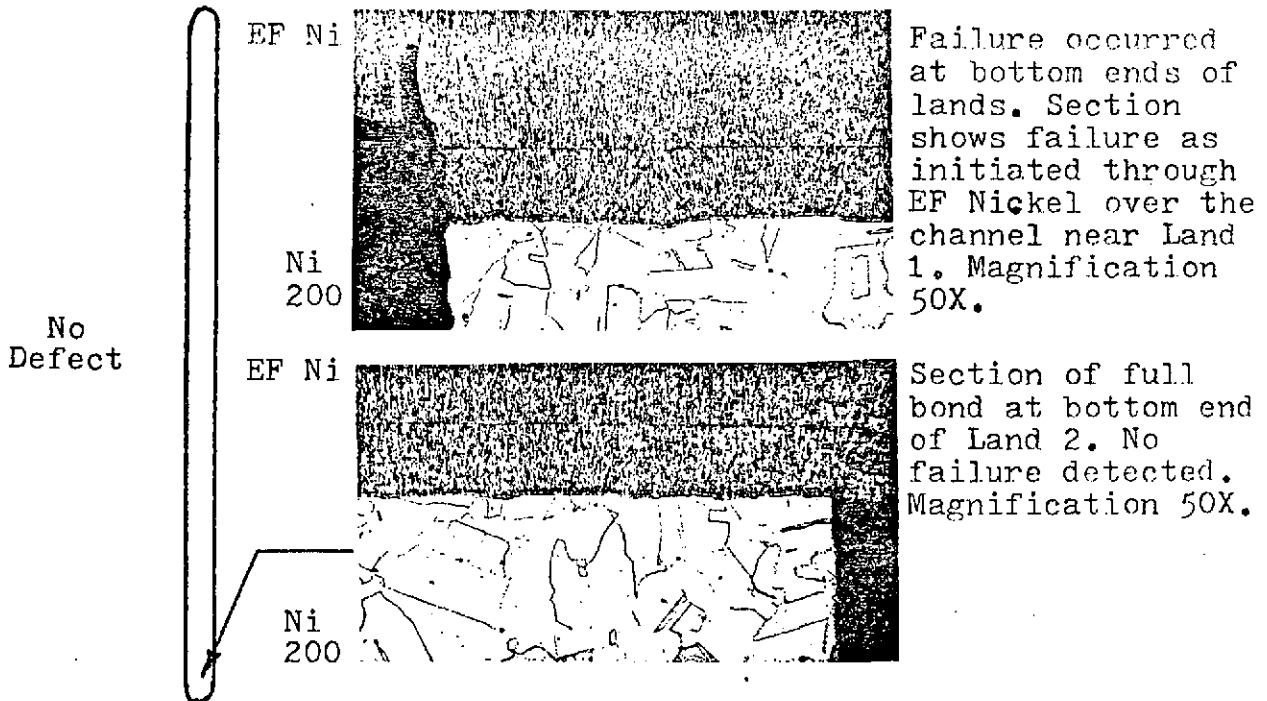
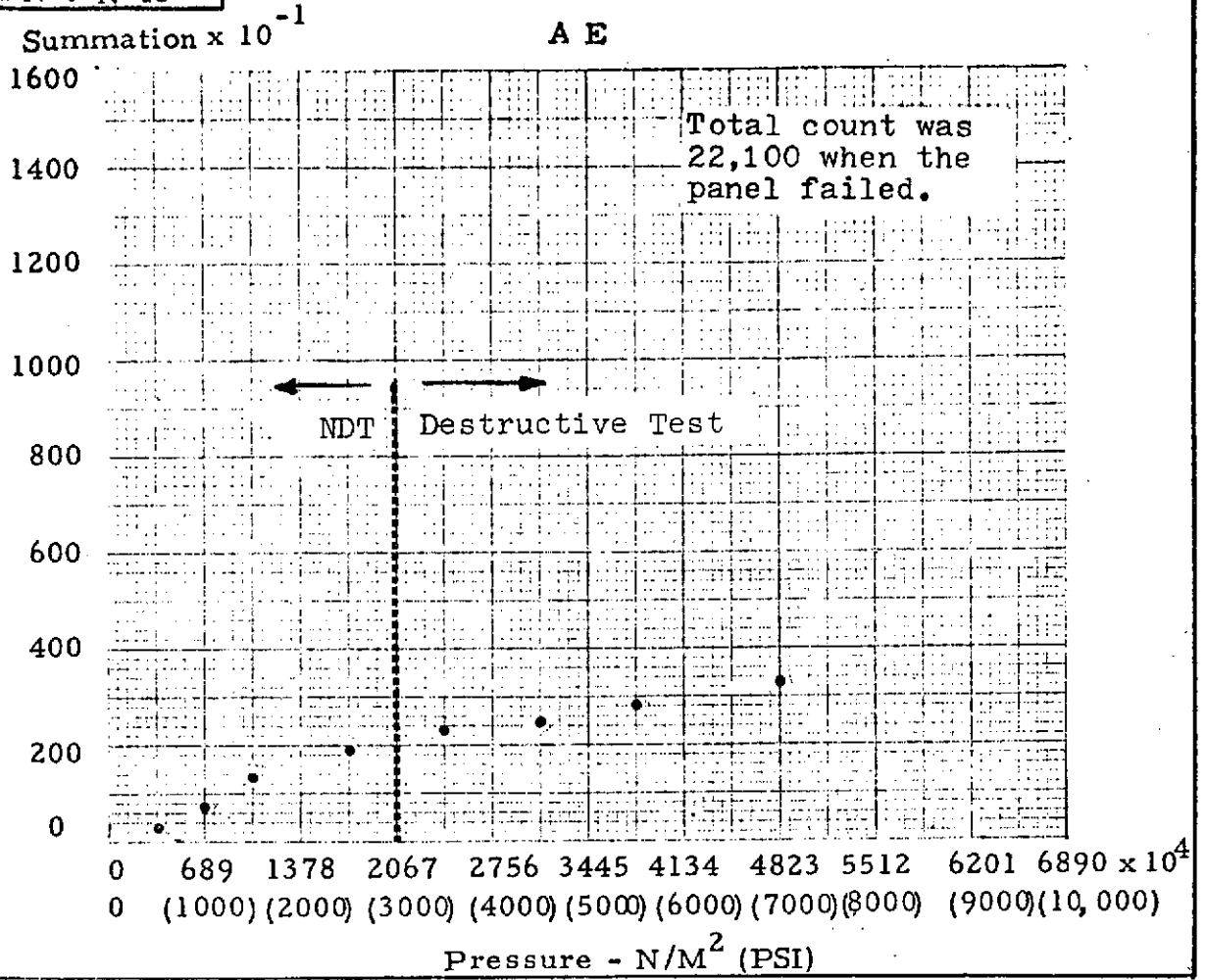


FIGURE C-16



HNDT (After AE)

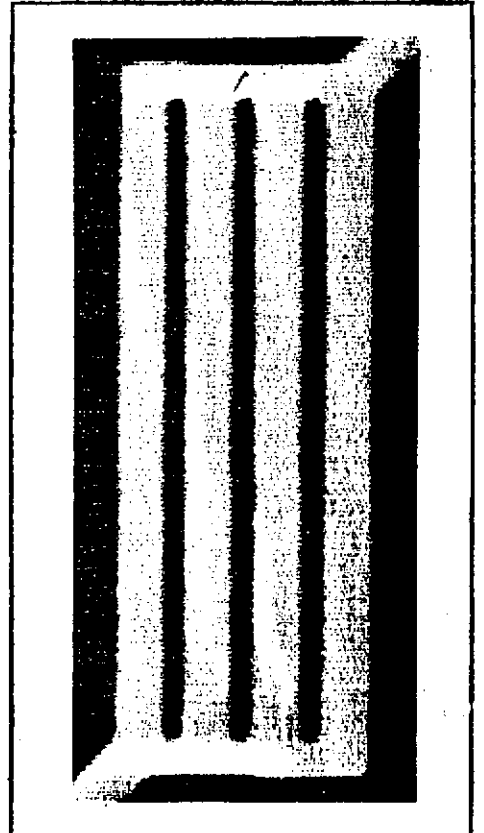


Press. - $20.7 \times 10^5 N/M^2$
(300 PSI)

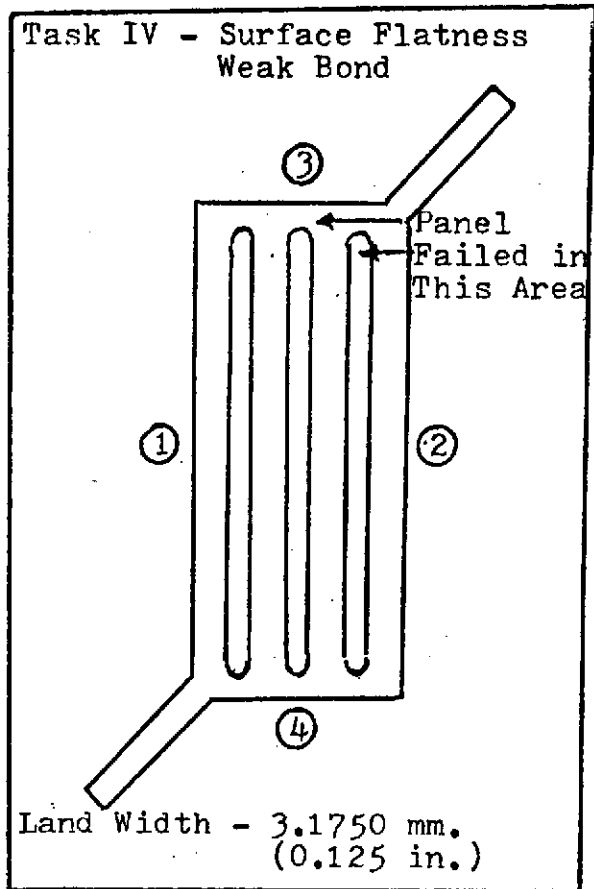
A E
FLAW LOCATOR
CENTER LAND



UT



ELECTROFORMED PANEL NO. N-46



BASEPLATE

MATERIAL: Nickel 200

CENTER LAND FLATNESS VARIATION:
0.003 in. (0.0762 mm.)

THICKNESS:	MM.	INCHES
①	6.2636	0.2466
②	6.2382	0.2456
③	6.2814	0.2473
④	6.2103	0.2445

COVERPLATE

MATERIAL: Electroformed Nickel

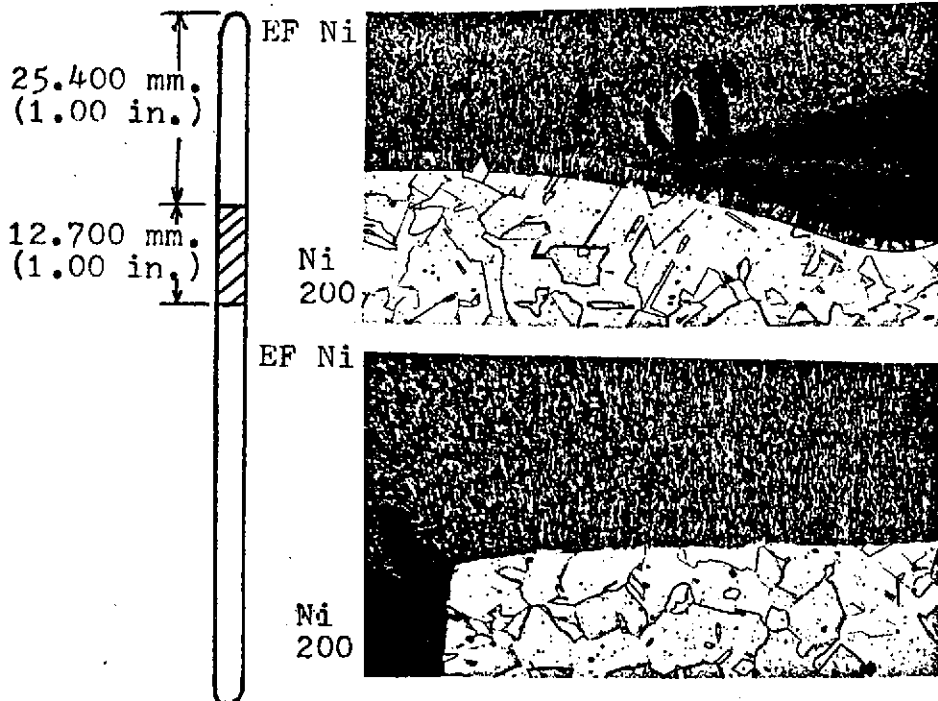
THICKNESS:	MM.	INCHES
①	0.8941	0.0352
②	0.9042	0.0356
③	0.7391	0.0291
④	1.0389	0.0409

PRESSURE REQUIRED TO FAIL BOND:

Panel failed at a pressure of
 $5.87 \times 10^7 \text{ N/m}^2$ (8,500 psi).

CENTER LAND DEFECT.

METALLOGRAPHIC ANALYSIS:

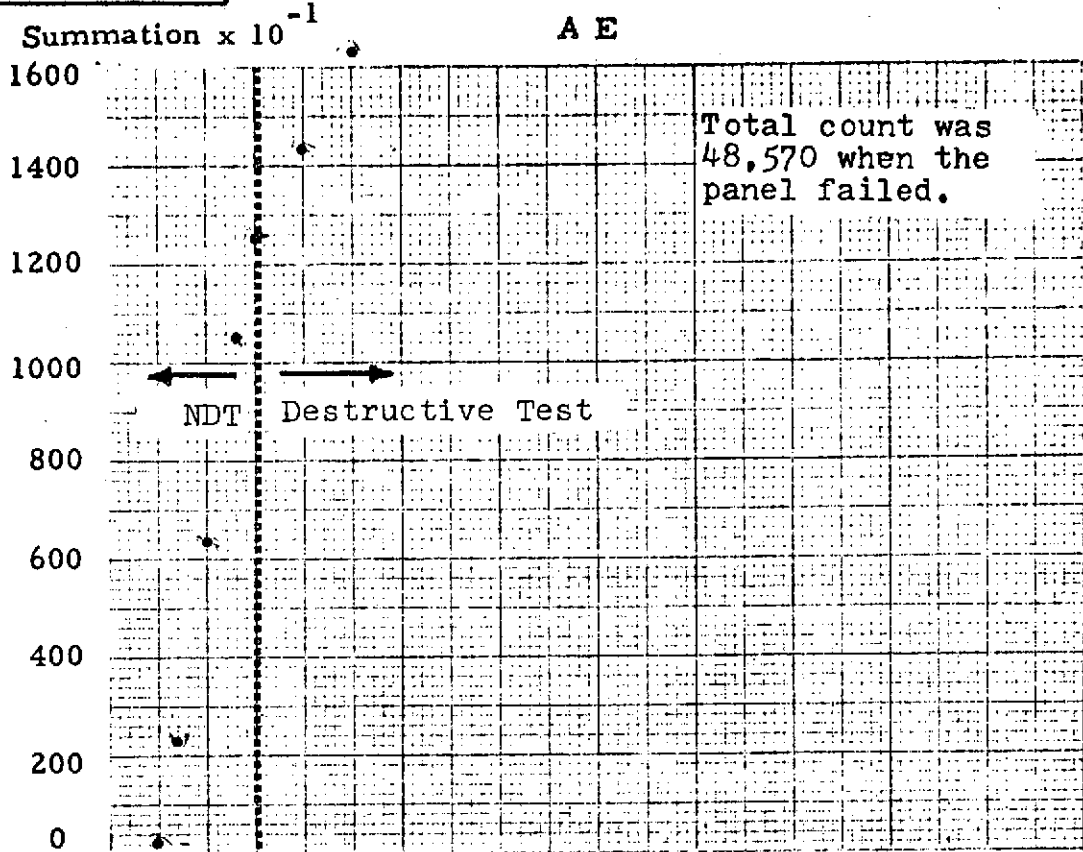


Section from the
planned weak bond
showing progress
of failure.
Magnification 50X.

Section of the
full bond from
Land 3 illustrat-
ing no bond fail-
ure, but some
tearing of the
thin coverplate
is evident.
Magnification 50X.

FIGURE C-17

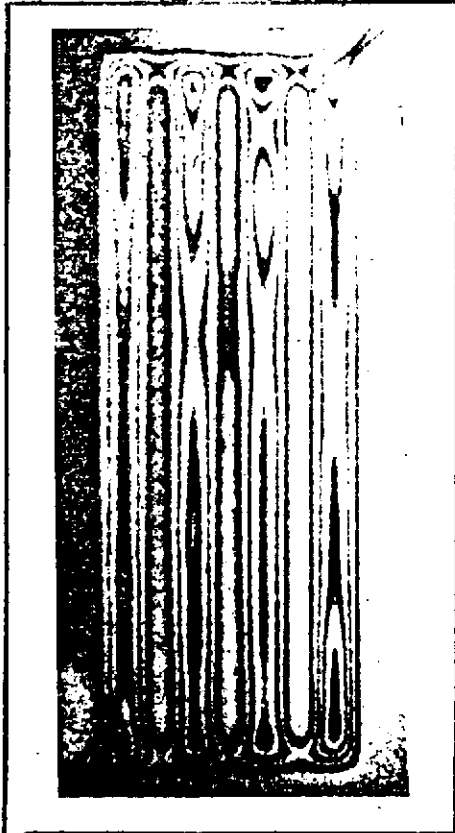
Panel No. N-46



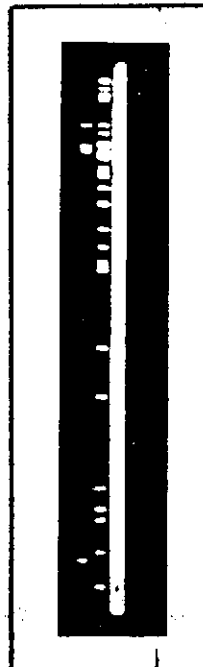
0 689 1378 2067 2756 3445 4134 4823 5512 6201 6890 $\times 10^3$
0 (1000) (2000) (3000) (4000) (5000) (6000) (7000) (8000) (9000) (10,000)

Pressure - N/M^2 (PSI)

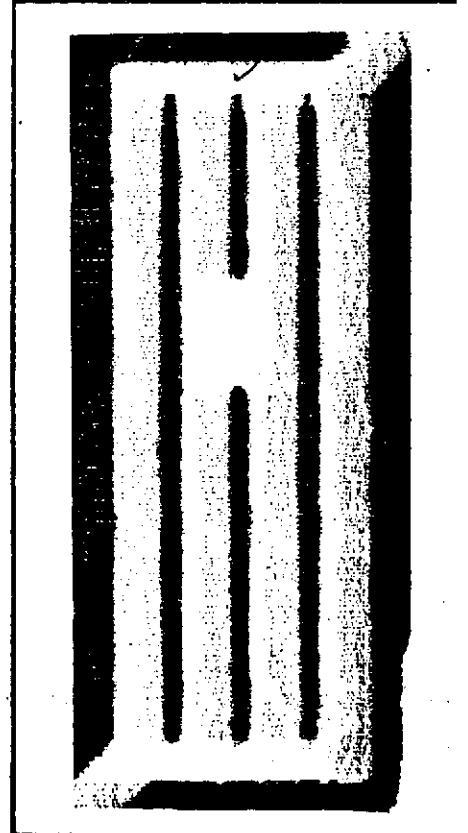
HNDT (Before AE)



AE
FLAW LOCATOR
CENTER LAND

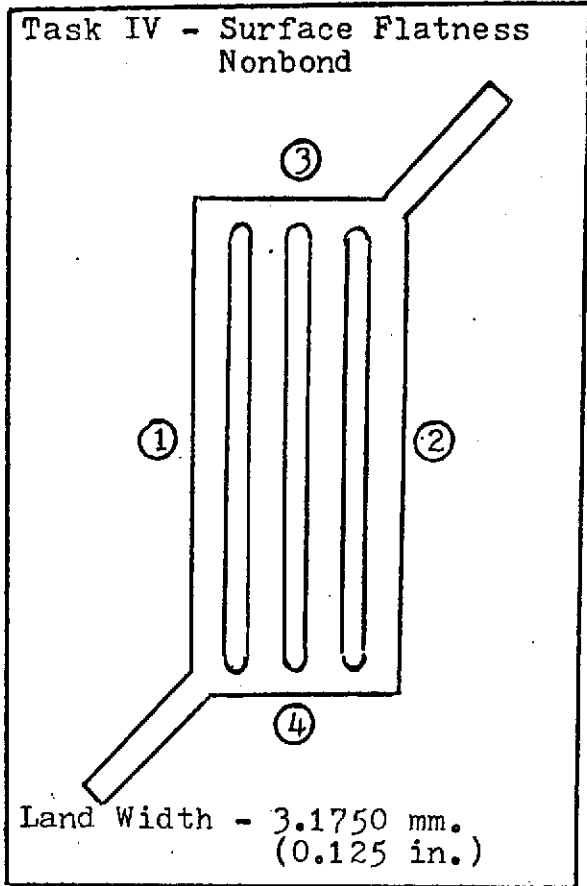


UT



Press. 13.8×10^5 N/M^2
(200 PSI)

ELECTROFORMED PANEL NO. N-42



BASEPLATE

MATERIAL: Nickel 200

CENTER LAND FLATNESS VARIATION:
0.005 in. (0.1270 mm.)

THICKNESS:	MM.	INCHES
①	6.2662	0.2467
②	6.2535	0.2462
③	6.2687	0.2468
④	6.2509	0.2461

COVERPLATE

MATERIAL: Electroformed Nickel

THICKNESS:	MM.	INCHES
①	0.8153	0.0321
②	0.8306	0.0327
③	0.7874	0.0310
④	0.9830	0.0387

PRESSURE REQUIRED TO FAIL BOND:

Panel failed at a pressure of
 $2.42 \times 10^7 \text{ N/m}^2$ (3,500 psi).

CENTER LAND DEFECT

METALLOGRAPHIC ANALYSIS:

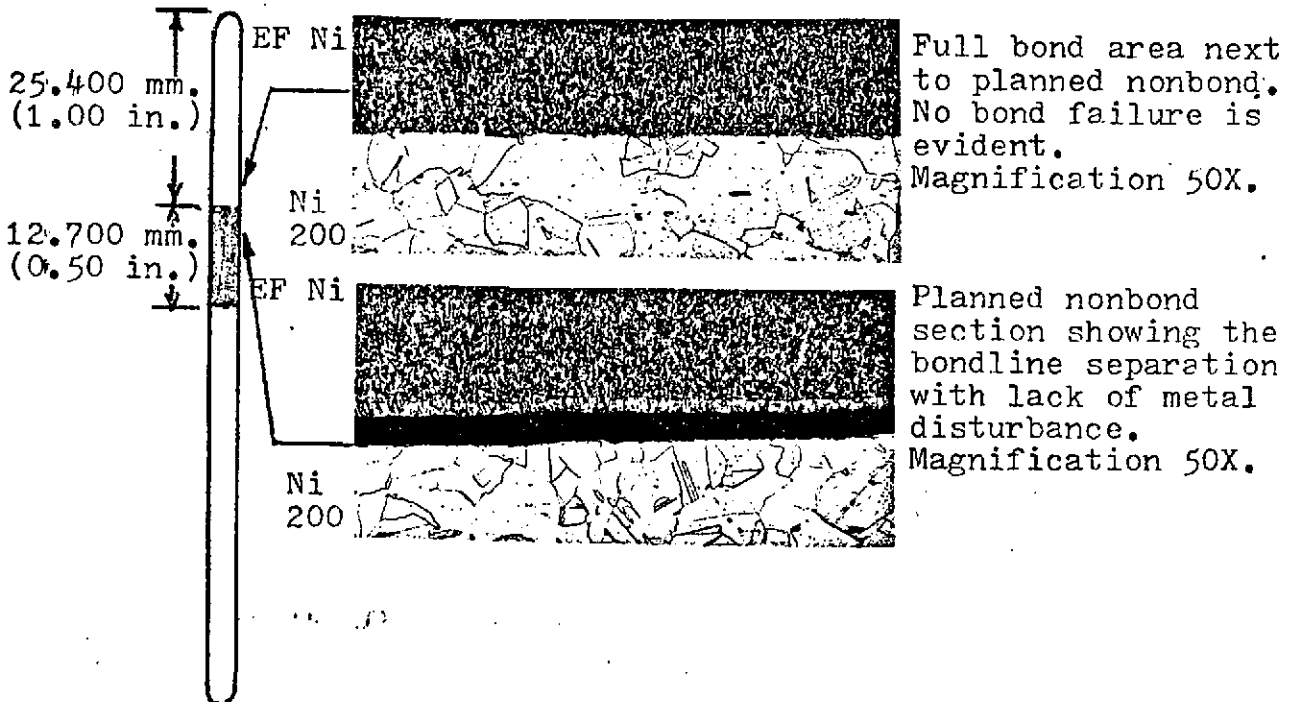
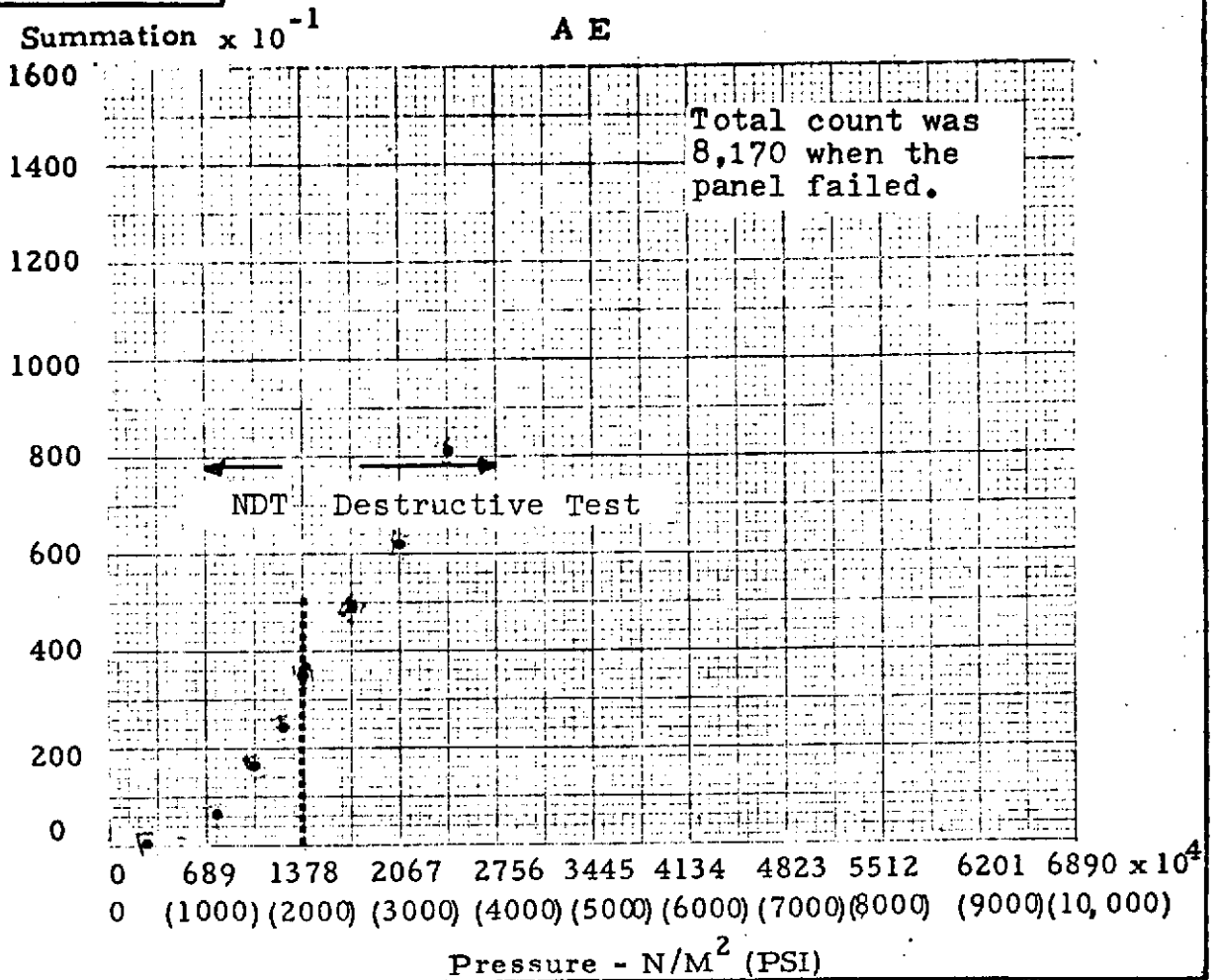
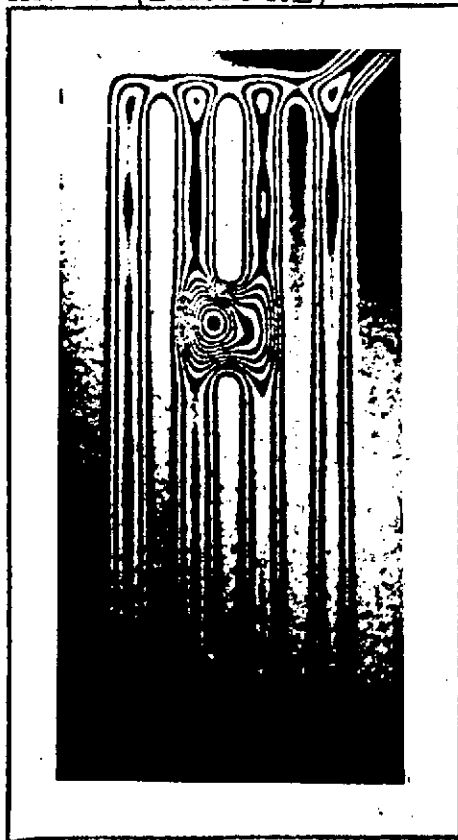


FIGURE C-18

Panel No. N-42



HNDT (Before AE)



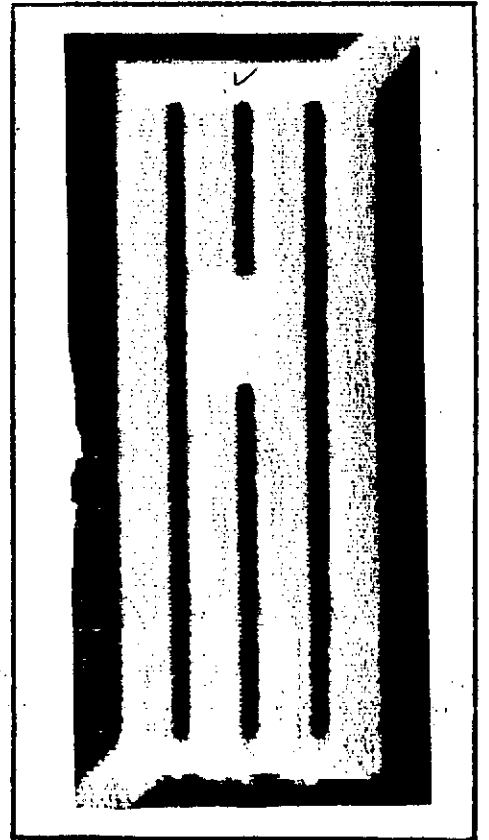
Press. 6.9×10^5 N/M^2
(100 PSI)

AE
FLAW LOCATOR
CENTER LAND

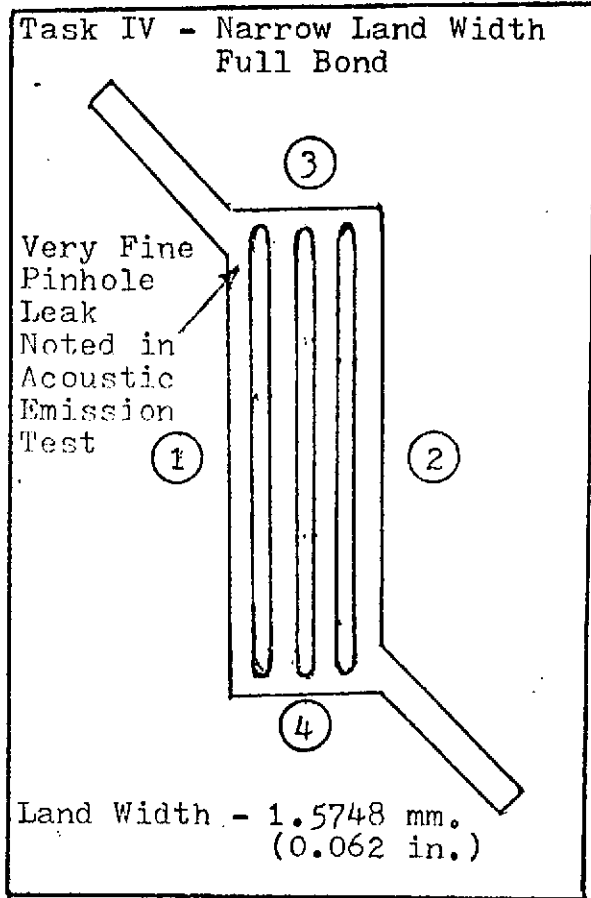


105

UT



ELECTROFORMED PANEL NO. N-56



BASEPLATE

MATERIAL: Nickel 200
CENTER LAND FLATNESS VARIATION:
0.0025 in. (0.0635 mm.)

THICKNESS:	MM.	INCHES
①	6.2128	0.2446
②	6.2814	0.2473
③	6.2738	0.2470
④	6.2154	0.2447

COVERPLATE

MATERIAL: Electroformed Nickel

THICKNESS:	MM.	INCHES
①	1.0033	0.0395
②	0.9449	0.0372
③	0.9627	0.0379
④	1.0312	0.0406

PRESSURE REQUIRED TO FAIL BOND:

Not destructively tested. Panel was fabricated to demonstrate NDE response on narrower lands only.

CENTER LAND DEFECT

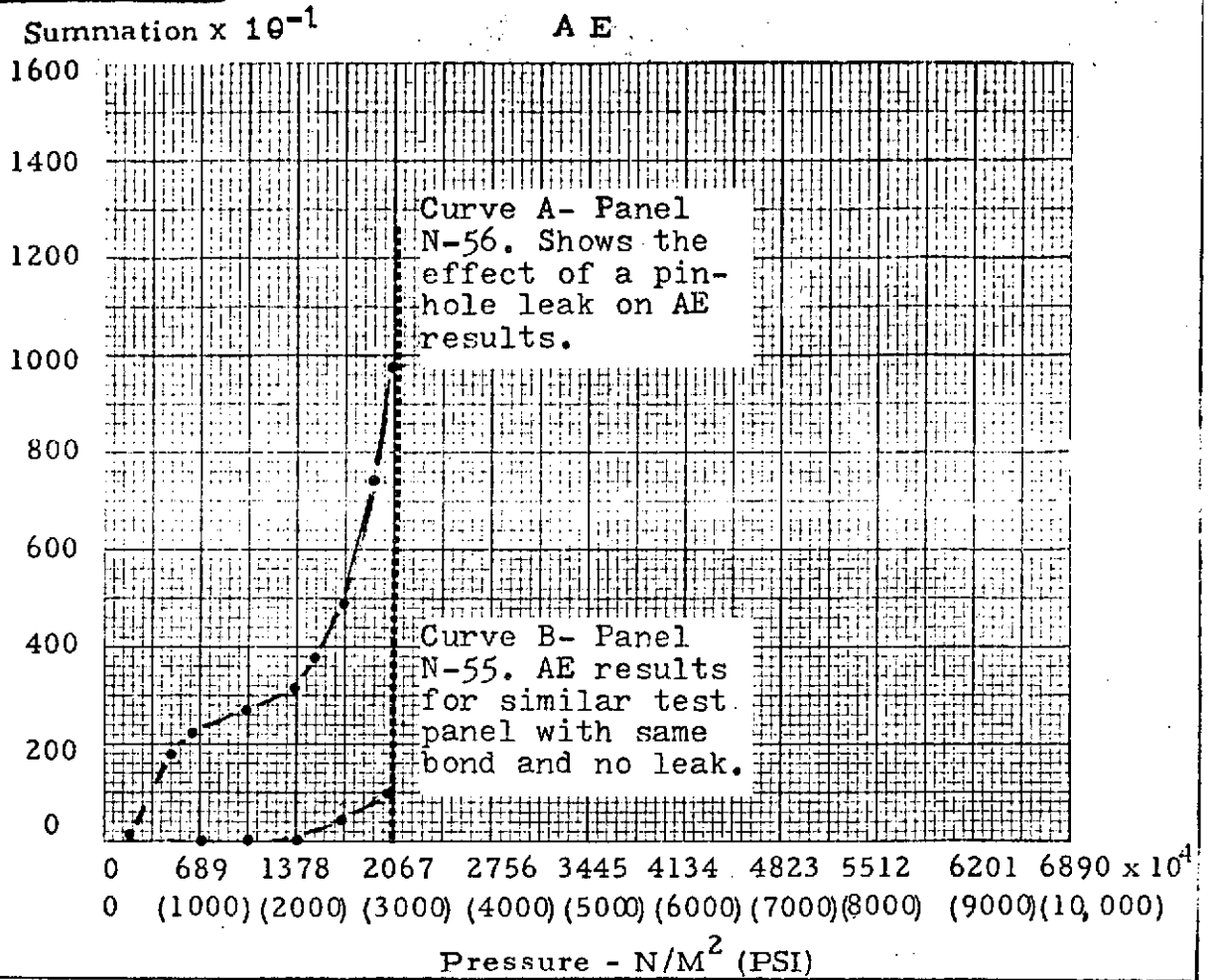
METALLURGICAL ANALYSIS: Not Required.

No Defect

A low pressure pinhole type leak was noted in Panel N-56 during acoustic emission test. Although this condition can be effectively repaired, the results were shown as experienced for informational purposes. Panel N-55, an identical panel except for slightly thicker coverplate, was similarly tested by acoustic emission and the results plotted for the comparison shown on Page 107. Panel N-55 exhibited no leaks. Note the flaw locator response to the leak detected on Panel N-56.

FIGURE C-19

Panel No. N-56

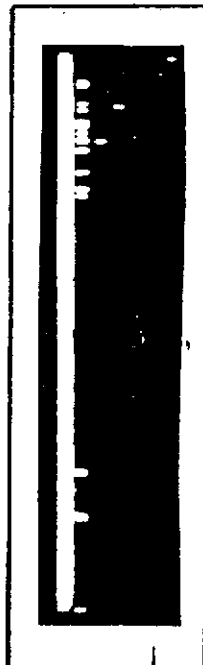


HNDT (Before AE)

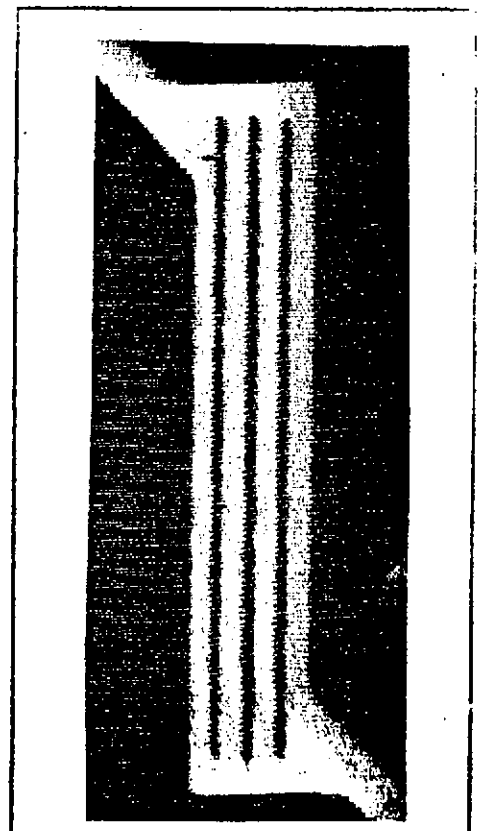


Press. 20.7 x 10⁵ N/M²
(300 PSI)

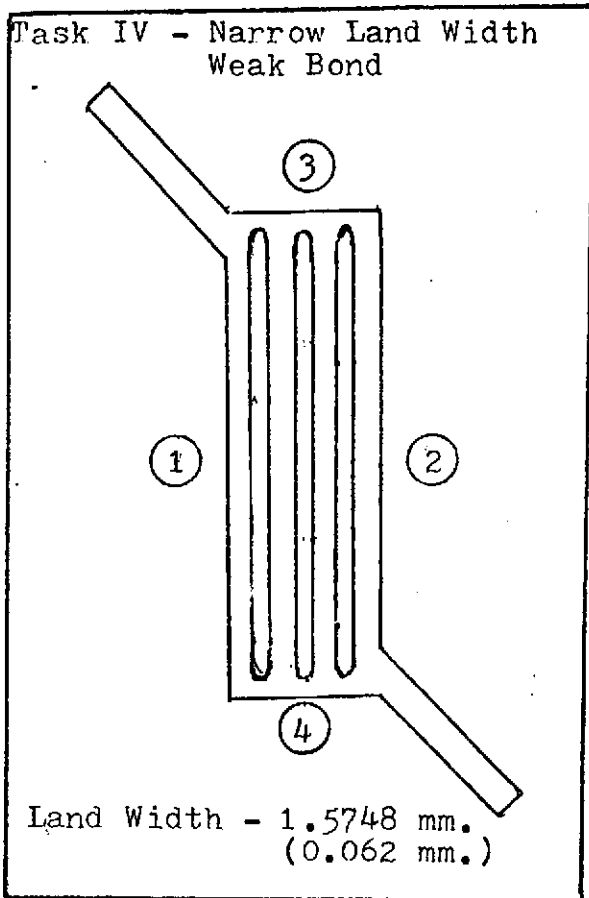
AE
FLAW LOCATOR
CENTER LAND



UT



ELECTROFORMED PANEL NO. N-57



BASEPLATE

MATERIAL: Nickel 200
CENTER LAND FLATNESS VARIATION:
0.003 in. (0.0762 mm.).

THICKNESS:	MM.	INCHES
①	6.2433	0.2458
②	6.2408	0.2457
③	6.2484	0.2460
④	6.2357	0.2455

COVERPLATE

MATERIAL: Electroformed Nickel

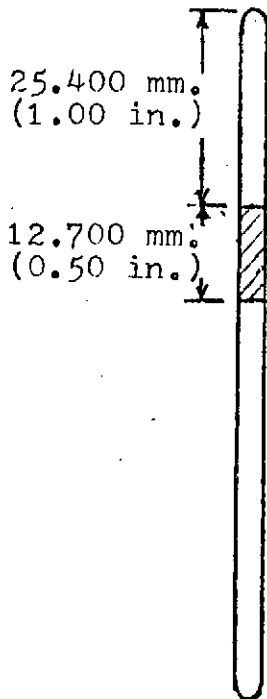
THICKNESS:	MM.	INCHES
①	1.0262	0.0404
②	1.0389	0.0409
③	1.0312	0.0406
④	1.0135	0.0399

PRESSURE REQUIRED TO FAIL BOND:

Not destructively tested. Panel was fabricated to demonstrate NDE response on narrower lands only.

CENTER LAND DEFECT

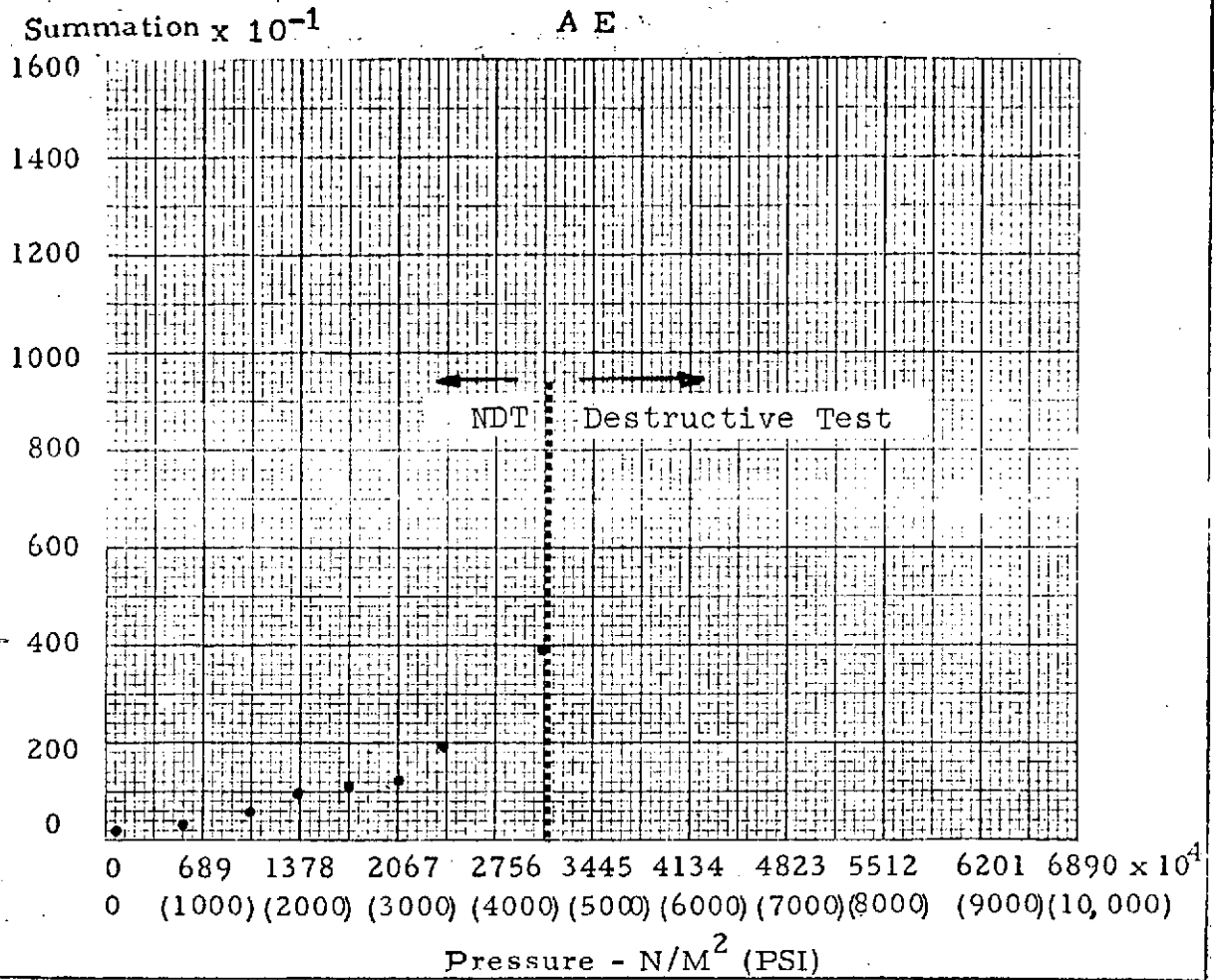
METALLURGICAL ANALYSIS: Not Required.



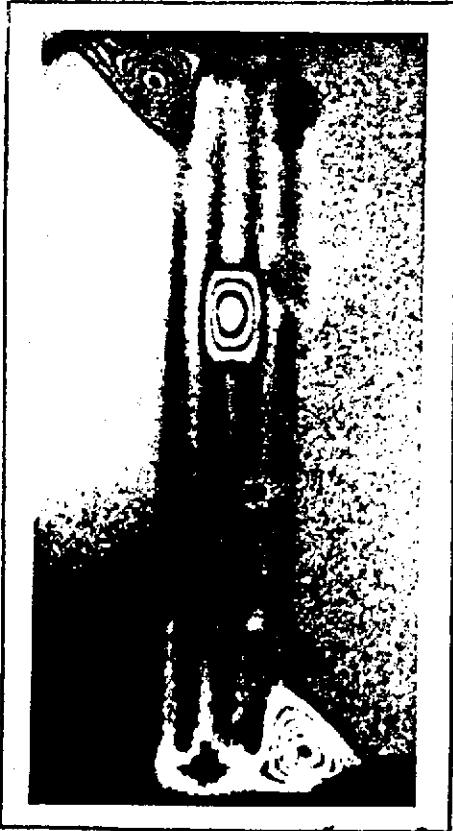
Planned weak bond was actually a nonbond as disclosed by ultrasonic "C" scan and holography. The low pressure acoustic response did not show the high count normal for weak bonds.

FIGURE C-20

Panel No. N-57

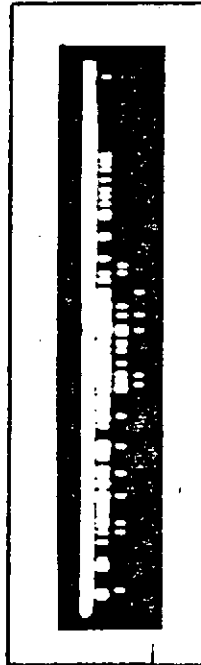


HNDT (Before AE)



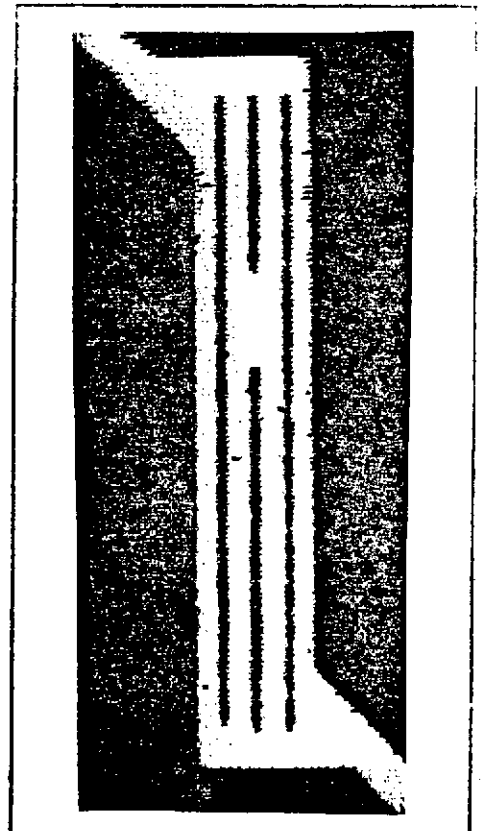
Press. $3.45 \times 10^5 N/M^2$
(50 PSI)

AE
FLAW LOCATOR
CENTER LAND

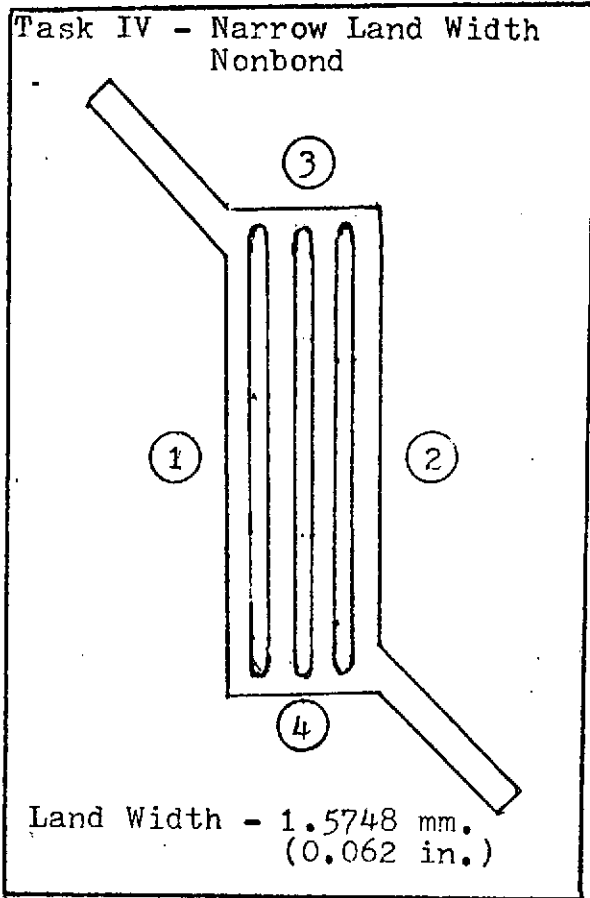


109

UT



ELECTROFORMED PANEL NO. N-58



BASEPLATE

MATERIAL: Nickel 200
CENTER LAND FLATNESS VARIATION:
0.0065 in. (0.1651 mm.)

THICKNESS:	MM.	INCHES
①	6.2128	0.2446
②	6.2027	0.2442
③	6.1951	0.2439
④	6.2053	0.2443

COVERPLATE

MATERIAL: Electroformed Nickel

THICKNESS:	MM.	INCHES
①	1.0328	0.0407
②	1.0389	0.0409
③	0.8966	0.0353
④	0.9398	0.0370

PRESSURE REQUIRED TO FAIL BOND:

Not destructively tested. Panel was fabricated to demonstrate NDE response on narrower lands only.

CENTER LAND DEFECT

METALLURGICAL ANALYSIS: Not Required.

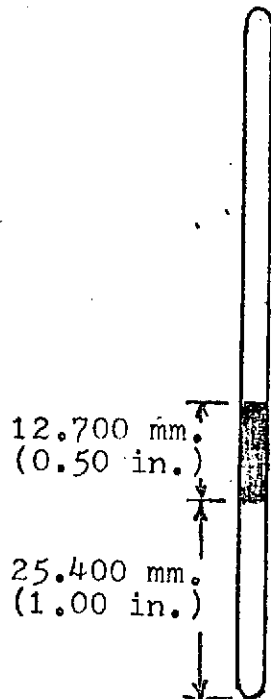
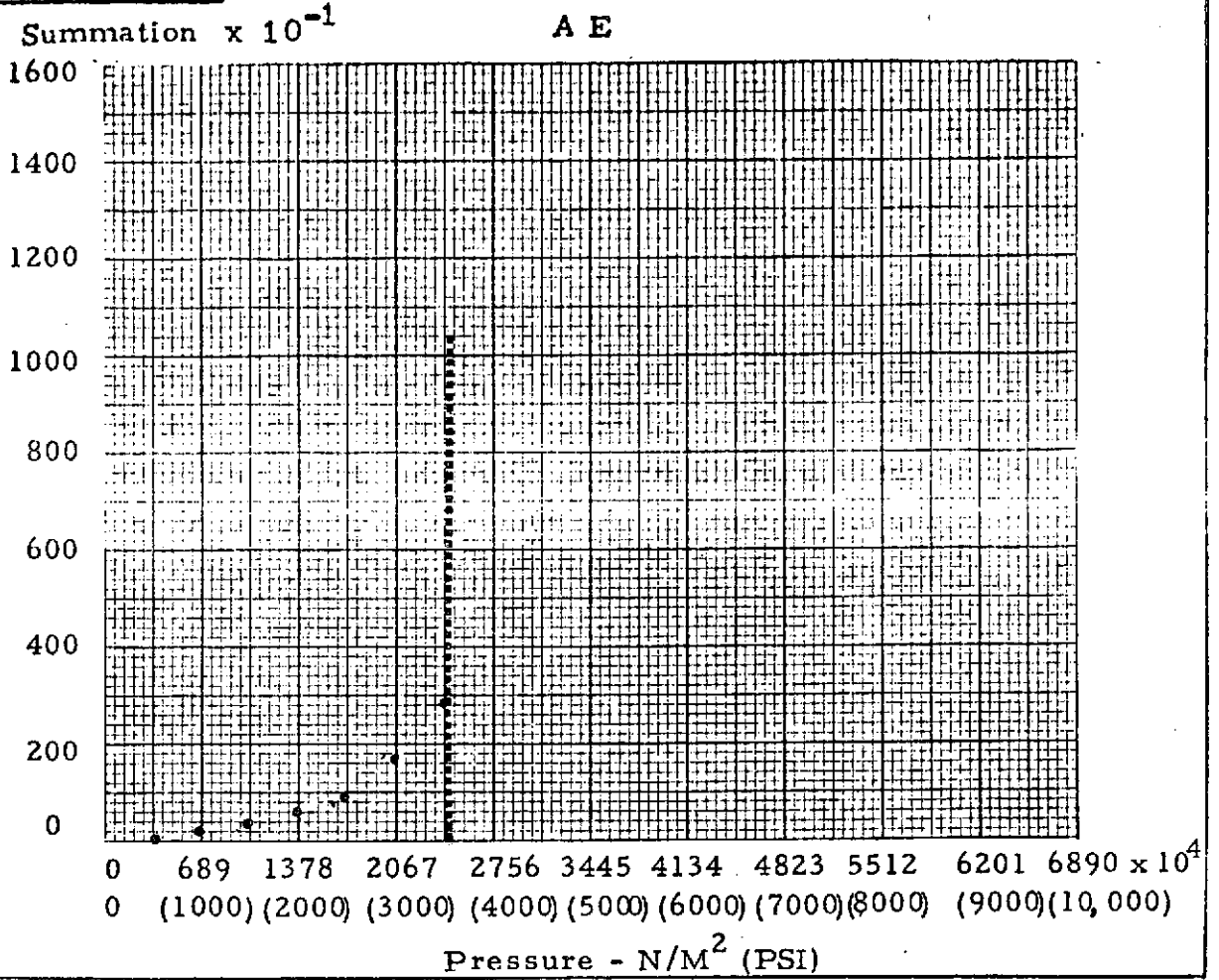


FIGURE C-21

Panel No. N-58



HNDT (Before AE)

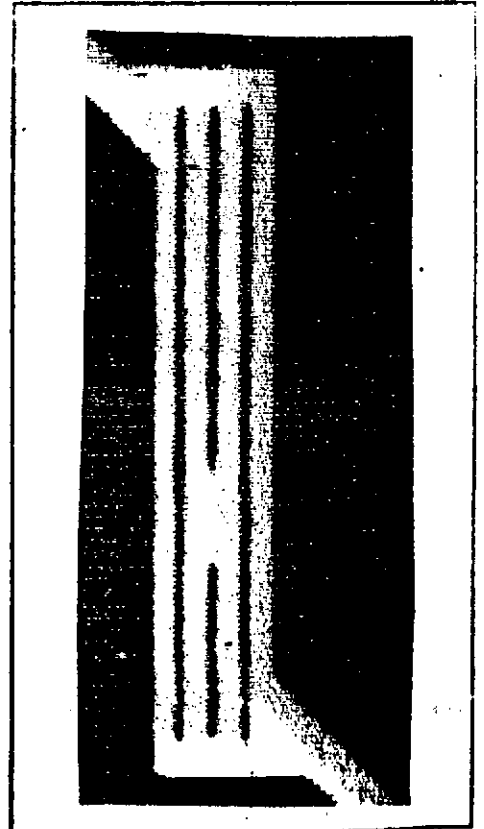


Press. 13.8×10^5 N/M²
(200 PSI)

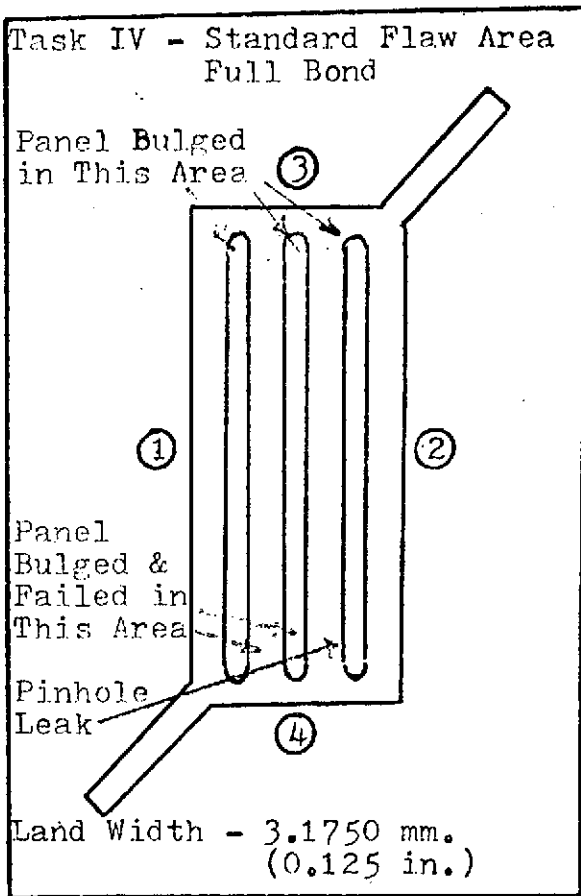
AE
FLAW LOCATOR
CENTER LAND



UT



ELECTROFORMED PANEL NO. C-08N "A"



BASEPLATE

MATERIAL: OFHC Copper
 CENTER LAND FLATNESS VARIATION:
 0.001 in. (0.0254 mm.)

THICKNESS:	MM.	INCHES
①	6.0757	0.2392
②	6.0579	0.2385
③	6.0503	0.2382
④	6.0503	0.2382

COVERPLATE

MATERIAL: Electroformed Nickel

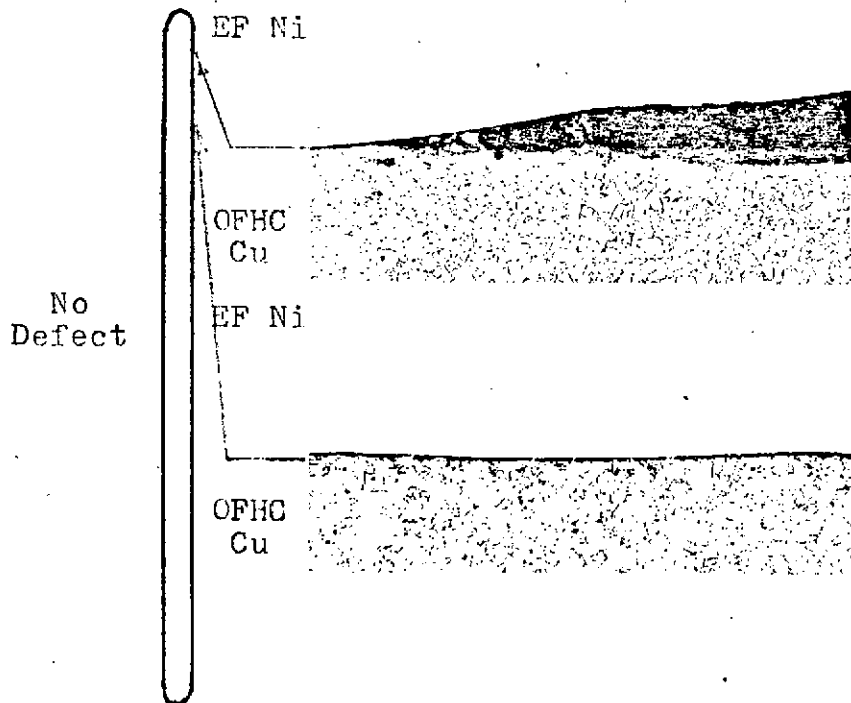
THICKNESS:	MM.	INCHES
①	0.9550	0.0376
②	0.9703	0.0382
③	0.9449	0.0372
④	0.9957	0.0392

PRESSURE REQUIRED TO FAIL BOND:

Bond failure occurred at a pressure of 4.62×10^7 N/m² (6,700 psi).

CENTER LAND DEFECT

METALLOGRAPHIC ANALYSIS:

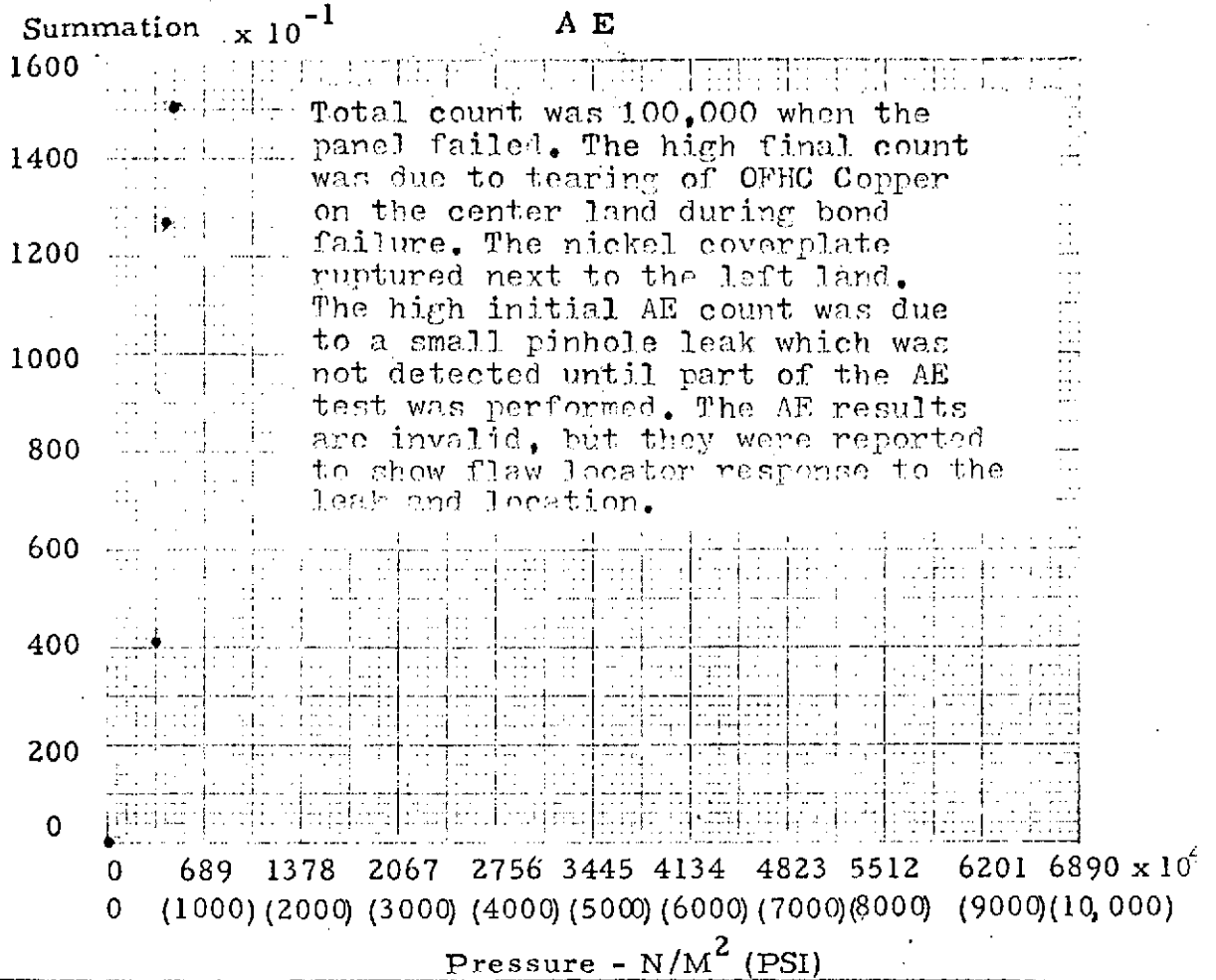


Area of planned full bond showing failure after destructive test. Magnification 50X.

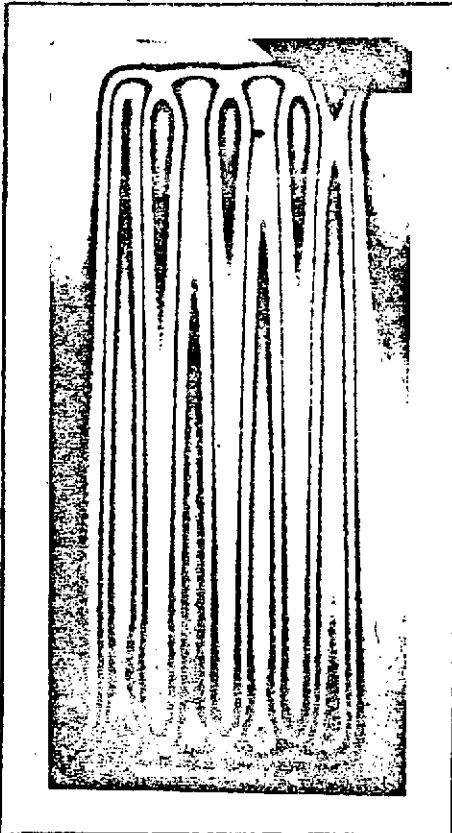
Area of planned full bond next to failed region. No failure noted. Magnification 50X.

FIGURE C-22

Panel No.C-8N'A''



HNDT (Before AE)

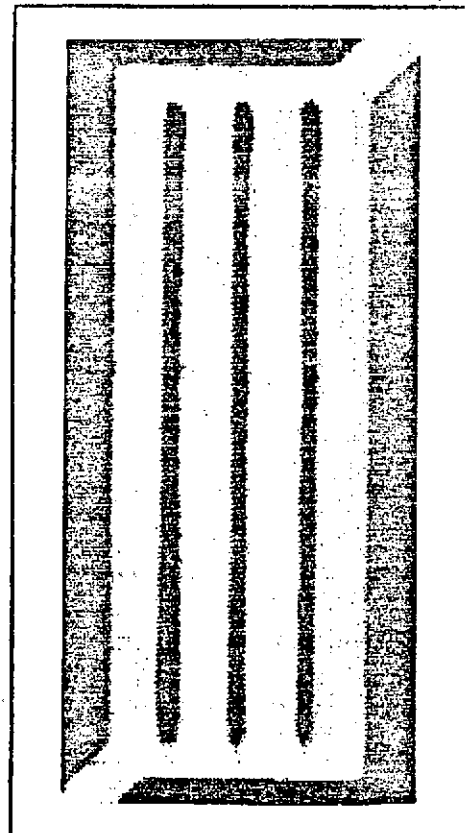


AE
FLAW LOCATOR
CENTER LAND



After NDE and
Destructive Test

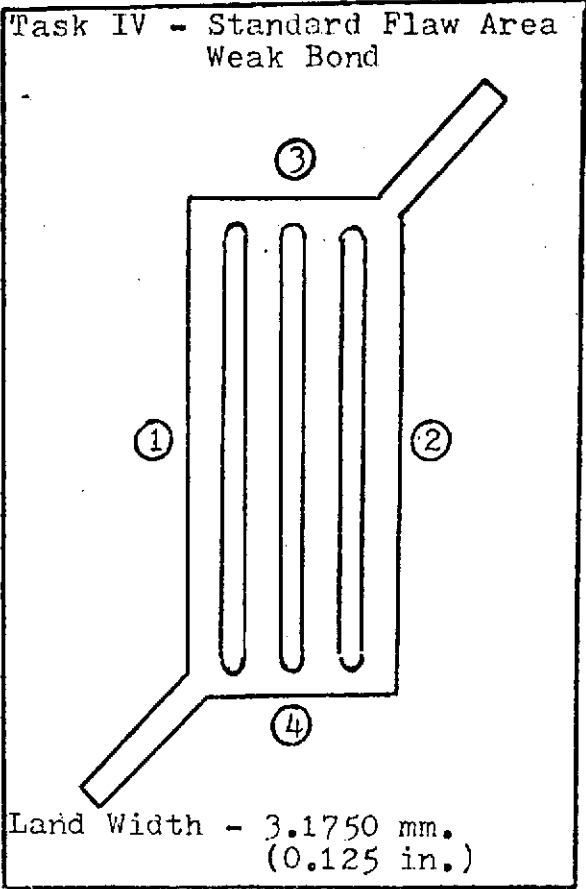
UT



REPRODUCIBILITY OF THE
ORIGINAL PAGE IS POOR

Press. 34.5×10^5 N/M^2
(500 PSI)

ELECTROFORMED PANEL NO. C-28N



BASEPLATE

MATERIAL: OFHC Copper

CENTER LAND FLATNESS VARIATION:
0.002 in. (0.0508 mm.)

THICKNESS:	MM.	INCHES
①	6.6192	0.2606
②	6.6015	0.2599
③	6.6091	0.2602
④	6.5964	0.2597

COVERPLATE

MATERIAL: Electroformed Nickel

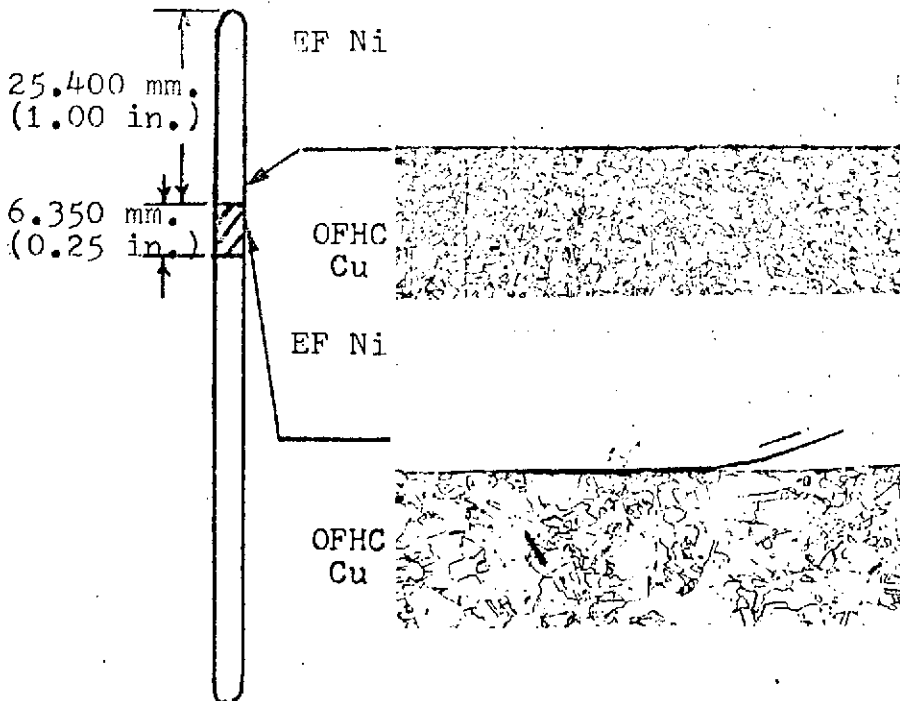
THICKNESS:	MM.	INCHES
①	0.9601	0.0378
②	0.9754	0.0384
③	0.9525	0.0375
④	0.9601	0.0378

PRESSURE REQUIRED TO FAIL BOND:

Bond failed at a pressure of
 5.18×10^7 N/m² (7,500 psi)

CENTER LAND DEFECT

METALLOGRAPHIC ANALYSIS:

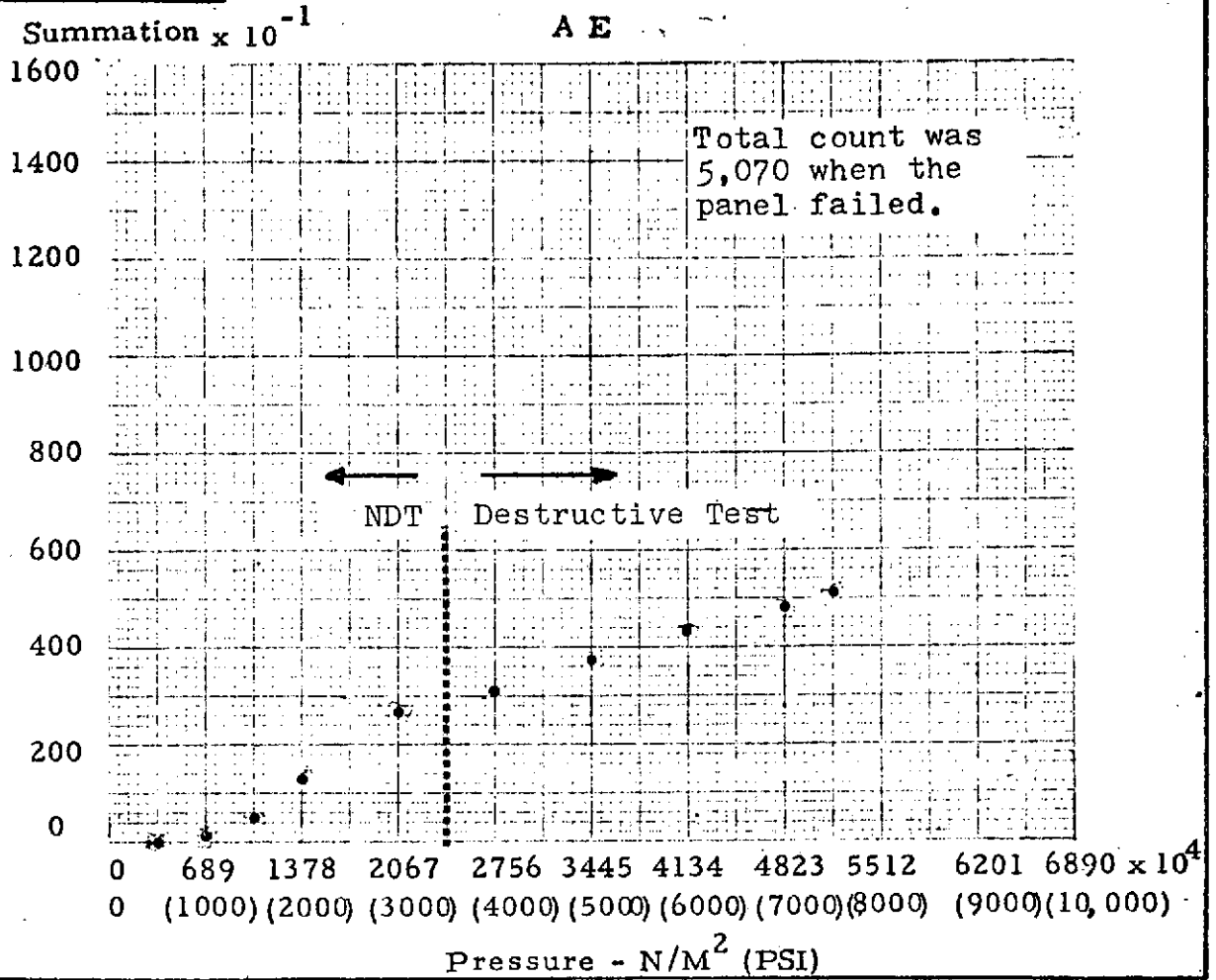


Section of full bond area adjacent to the planned weak bond. Magnification 50X.

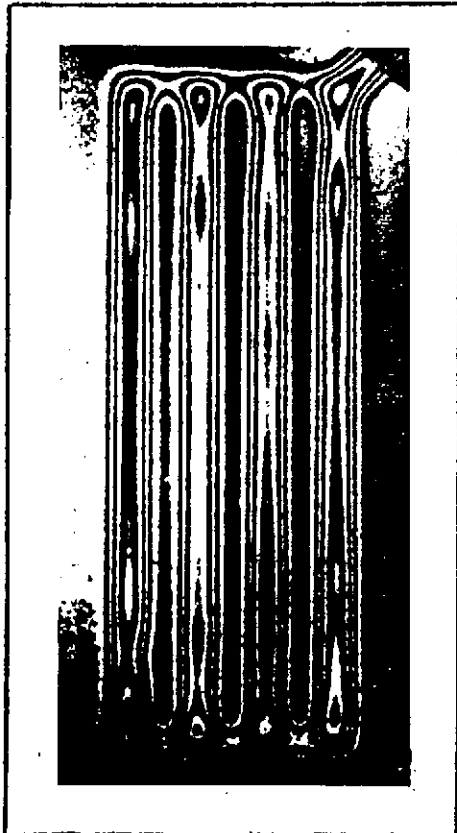
Section of planned weak bond. Preparation of specimen removed most of the failure. Some traces remain. Magnification 50X.

FIGURE C-23

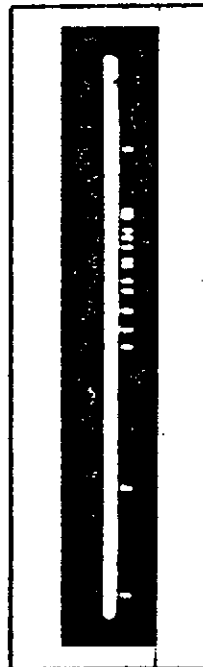
Panel No. C-28N



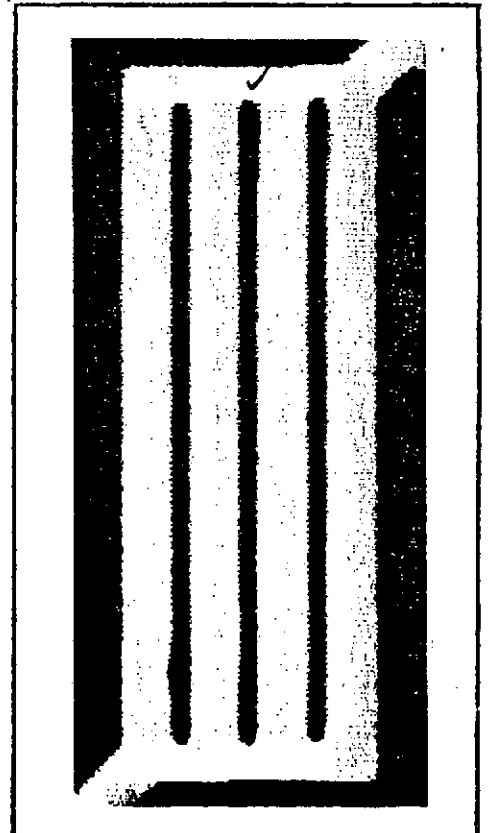
HNDT (Before AE)



AE
FLAW LOCATOR
CENTER LAND

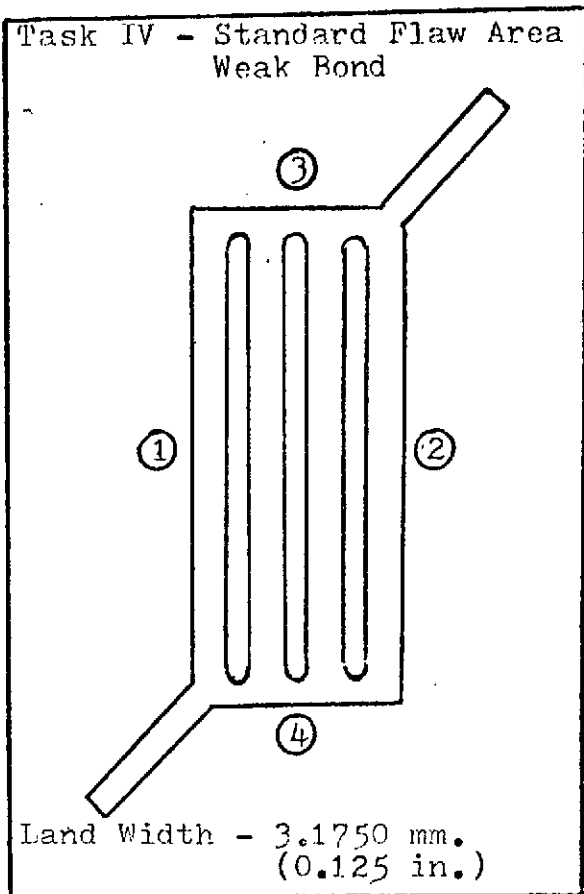


UT



Press. $13.8 \times 10^5 N/M^2$
(200 PSI)

ELECTROFORMED PANEL NO. C-29N



BASEPLATE

MATERIAL: OFHC Copper

CENTER LAND FLATNESS VARIATION:
0.001 in. (0.0254 mm.)

THICKNESS:	MM.	INCHES
①	6.4135	0.2525
②	6.3881	0.2515
③	6.4440	0.2537
④	6.3322	0.2493

COVERPLATE

MATERIAL: Electroformed Nickel

THICKNESS:	MM.	INCHES
①	0.9525	0.0375
②	0.9779	0.0385
③	0.9017	0.0355
④	1.0160	0.0400

PRESSURE REQUIRED TO FAIL BOND:

Bond failed at a pressure of
 $5.52 \times 10^7 \text{ N/m}^2$ (8,000 psi)

CENTER LAND DEFECT

METALLOGRAPHIC ANALYSIS:

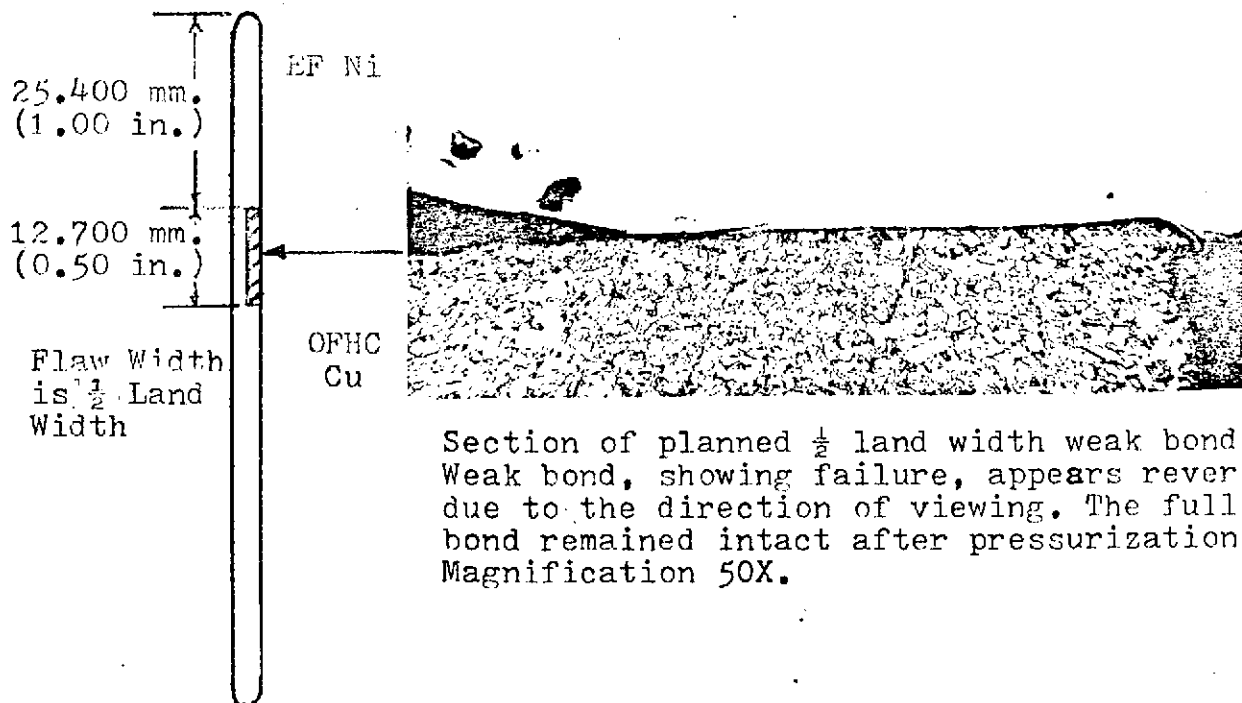


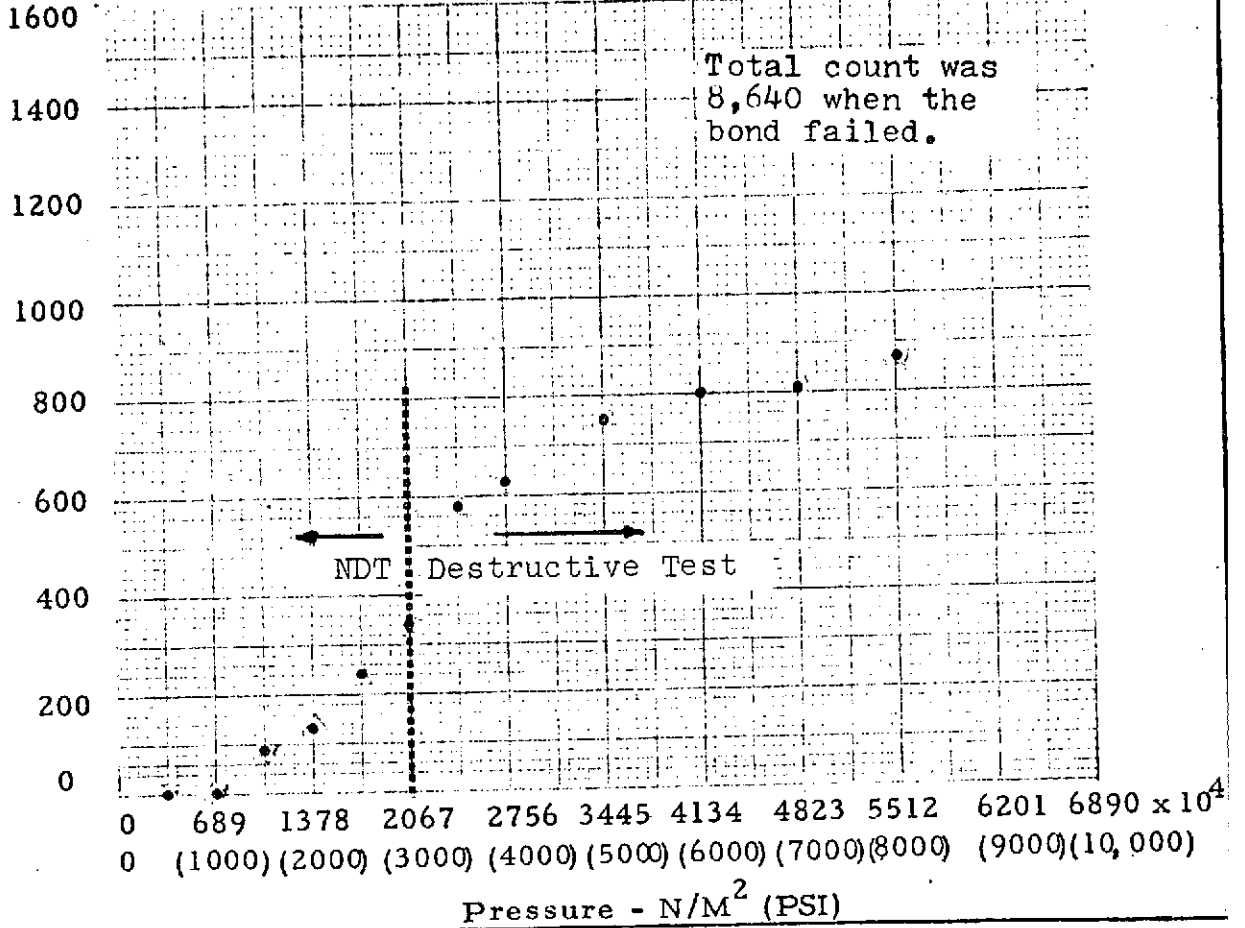
FIGURE C-24

Panel No. C-29N

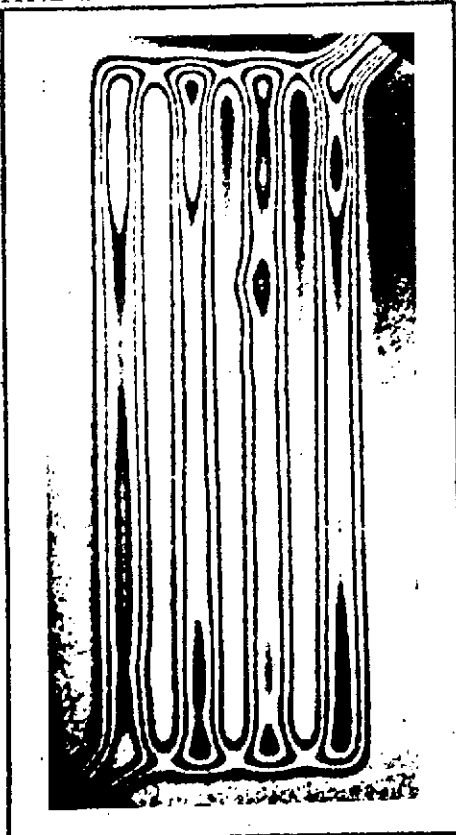
-1

A E

Summation x 10

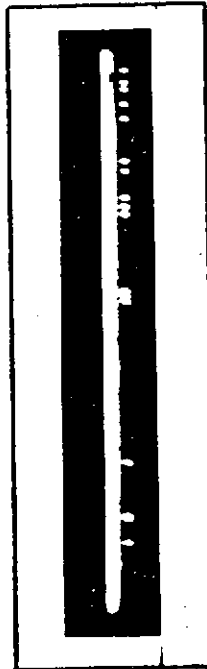


HNDT (Before AE)

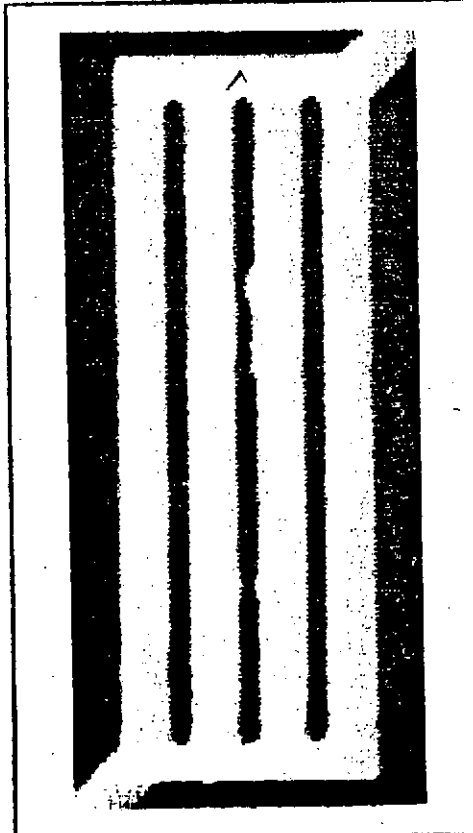


Press. - $13.8 \times 10^5 N/M^2$
(200 PSI)

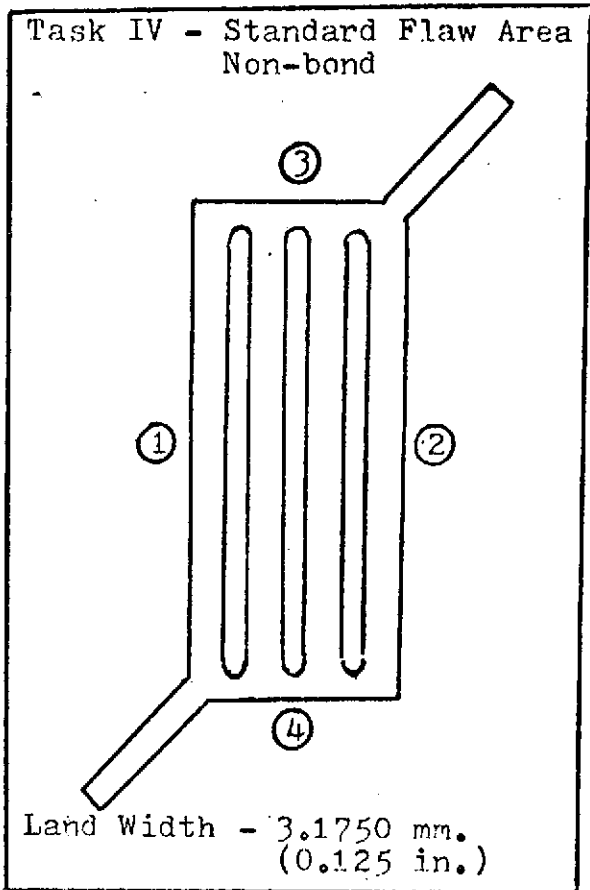
AE
FLAW LOCATOR
CENTER LAND



UT



ELECTROFORMED PANEL NO. C-30N



BASEPLATE

MATERIAL: OFHC Copper

CENTER LAND FLATNESS VARIATION:
0.001 in. (0.0254 mm.)

THICKNESS:	MM.	INCHES
①	6.5837	0.2592
②	6.5202	0.2567
③	6.5507	0.2579
④	6.5507	0.2579

COVERPLATE

MATERIAL: Electroformed Nickel

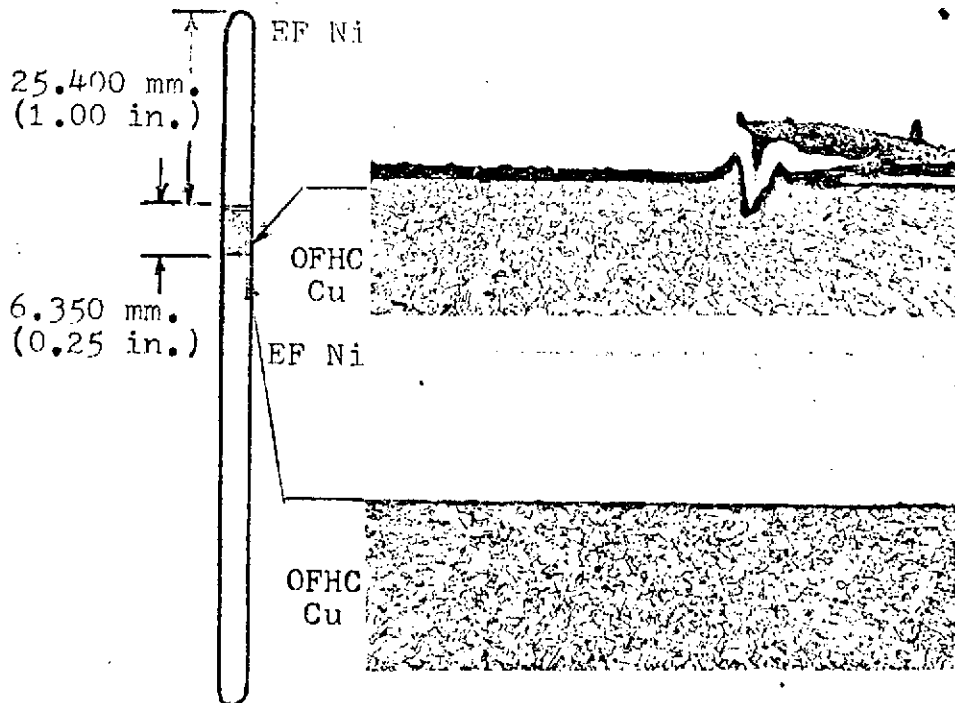
THICKNESS:	MM.	INCHES
①	0.9068	0.0357
②	0.9271	0.0365
③	0.9296	0.0366
④	0.9144	0.0360

PRESSURE REQUIRED TO FAIL BOND:

Bond failed at a pressure of
 $2.28 \times 10^7 \text{ N/m}^2$ (3,300 psi).

CENTER LAND DEFECT

METALLOGRAPHIC ANALYSIS:

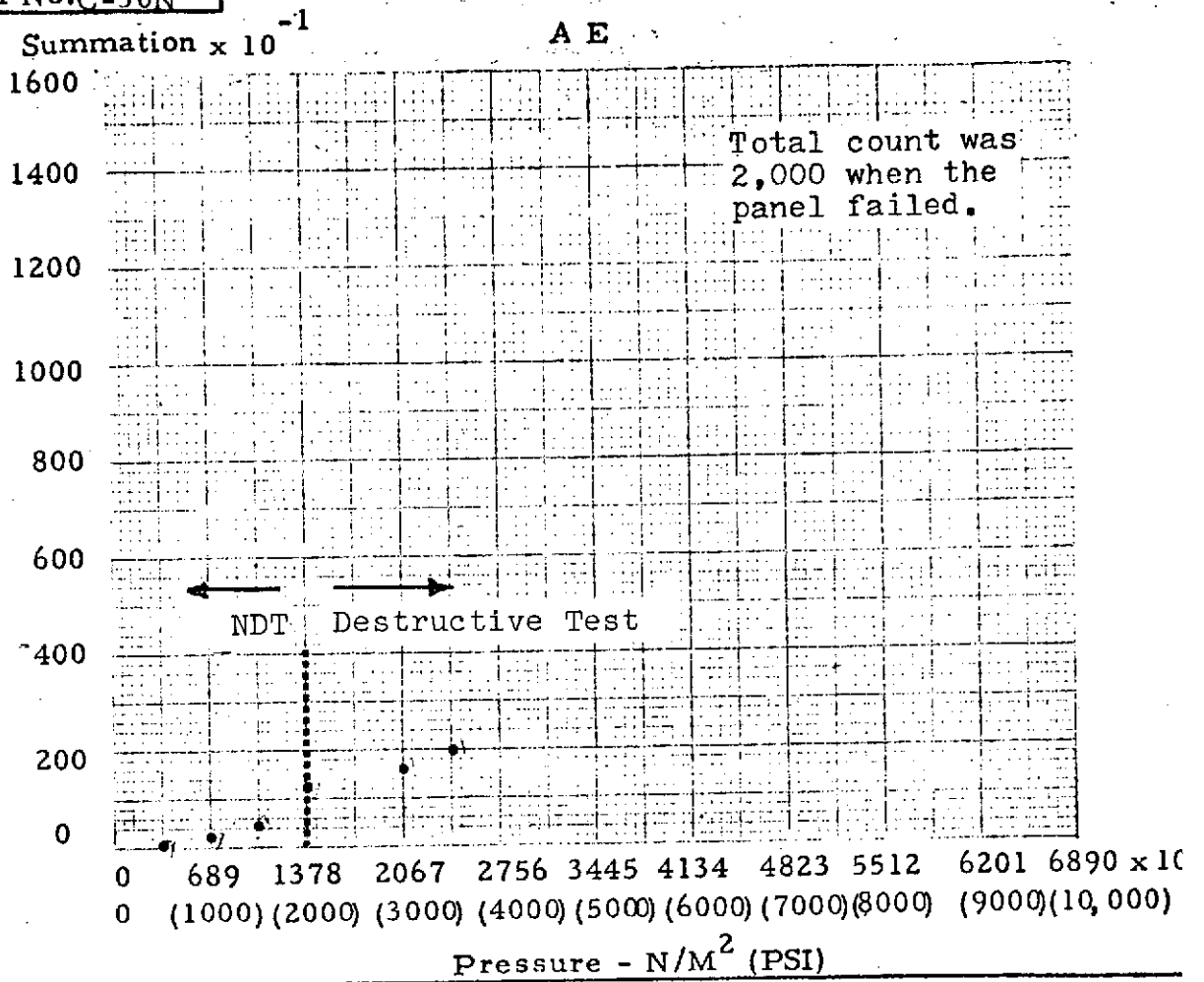


Section showing
termination of
nonbond as plan-
ned. Magnificat-
ion 50X.

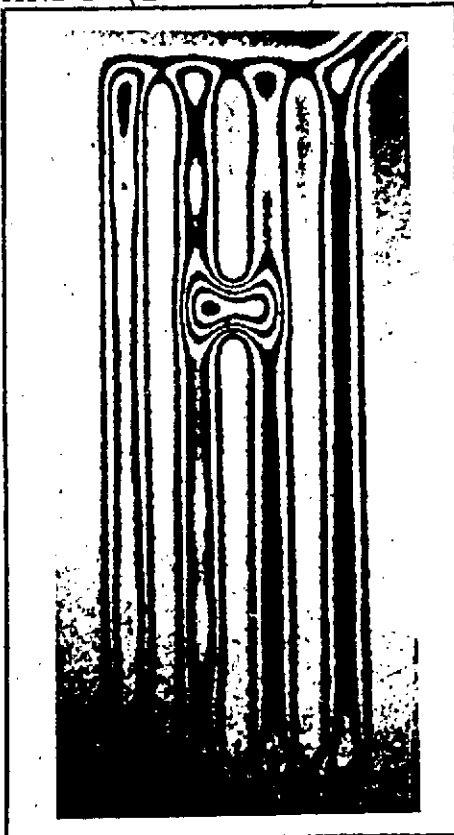
Planned full bond
area adjacent to
the nonbond.
Magnification 50X.

FIGURE C-25

Panel No. C-30N



HNDT (Before AE)



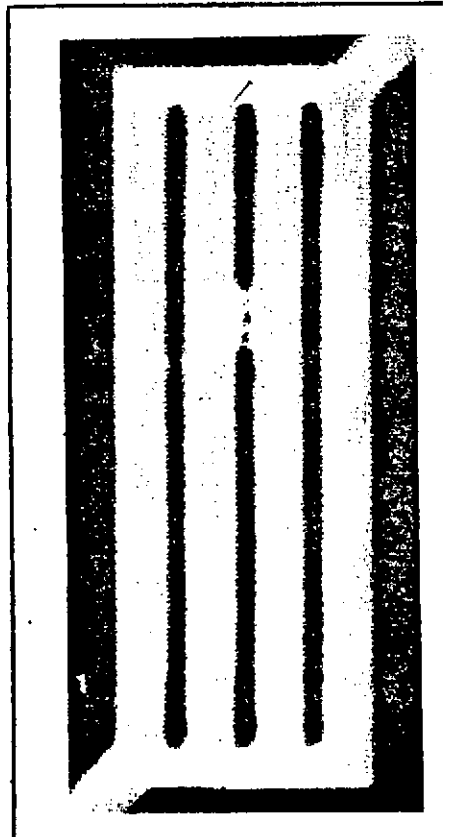
PRESS. - $6.9 \times 10^5 N/M^2$
(100 PSI)

AE
FLAW LOCATOR
CENTER LAND

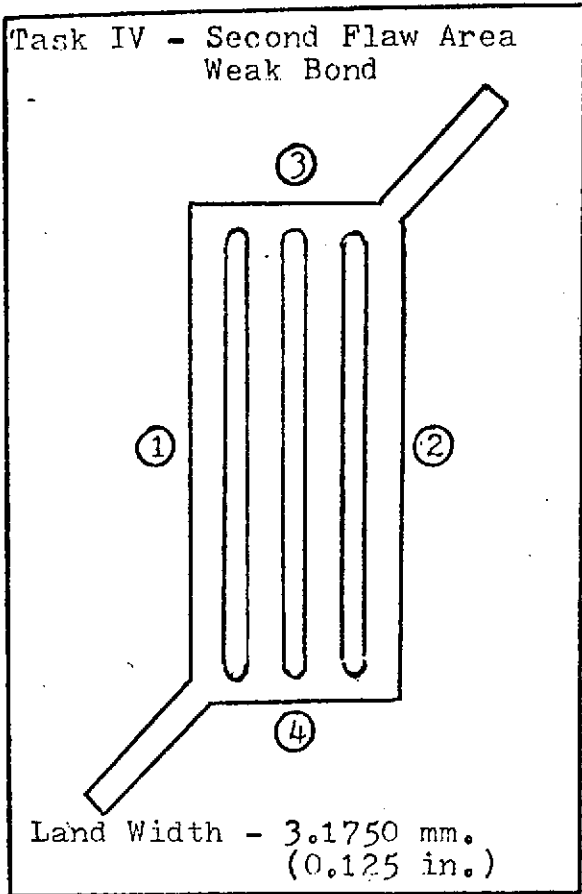


119

UT



ELECTROFORMED PANEL NO. C-32N



BASEPLATE

MATERIAL: OFHC Copper

CENTER LAND FLATNESS VARIATION:
0.0005 in. (0.0127 mm.)

THICKNESS:	MM.	INCHES
①	6.5608	0.2583
②	6.5837	0.2592
③	6.5456	0.2577
④	6.5583	0.2582

COVERPLATE

MATERIAL: Electroformed Nickel

THICKNESS:	MM.	INCHES
①	0.9652	0.0380
②	0.9068	0.0357
③	0.9601	0.0378
④	0.9296	0.0366

PRESSURE REQUIRED TO FAIL BOND:

Bond failed at a pressure of
 $2.76 \times 10^7 \text{ N/m}^2$ (4,000 psi)

CENTER LAND DEFECT

METALLOGRAPHIC ANALYSIS:

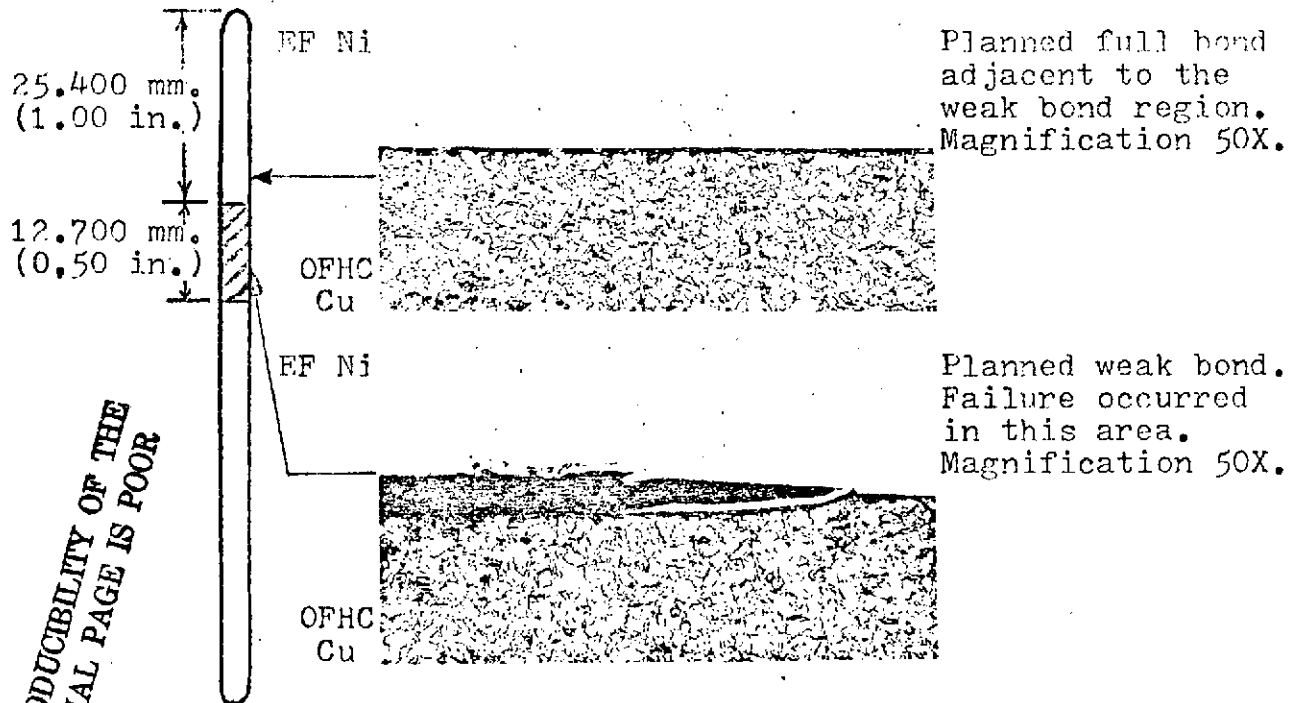
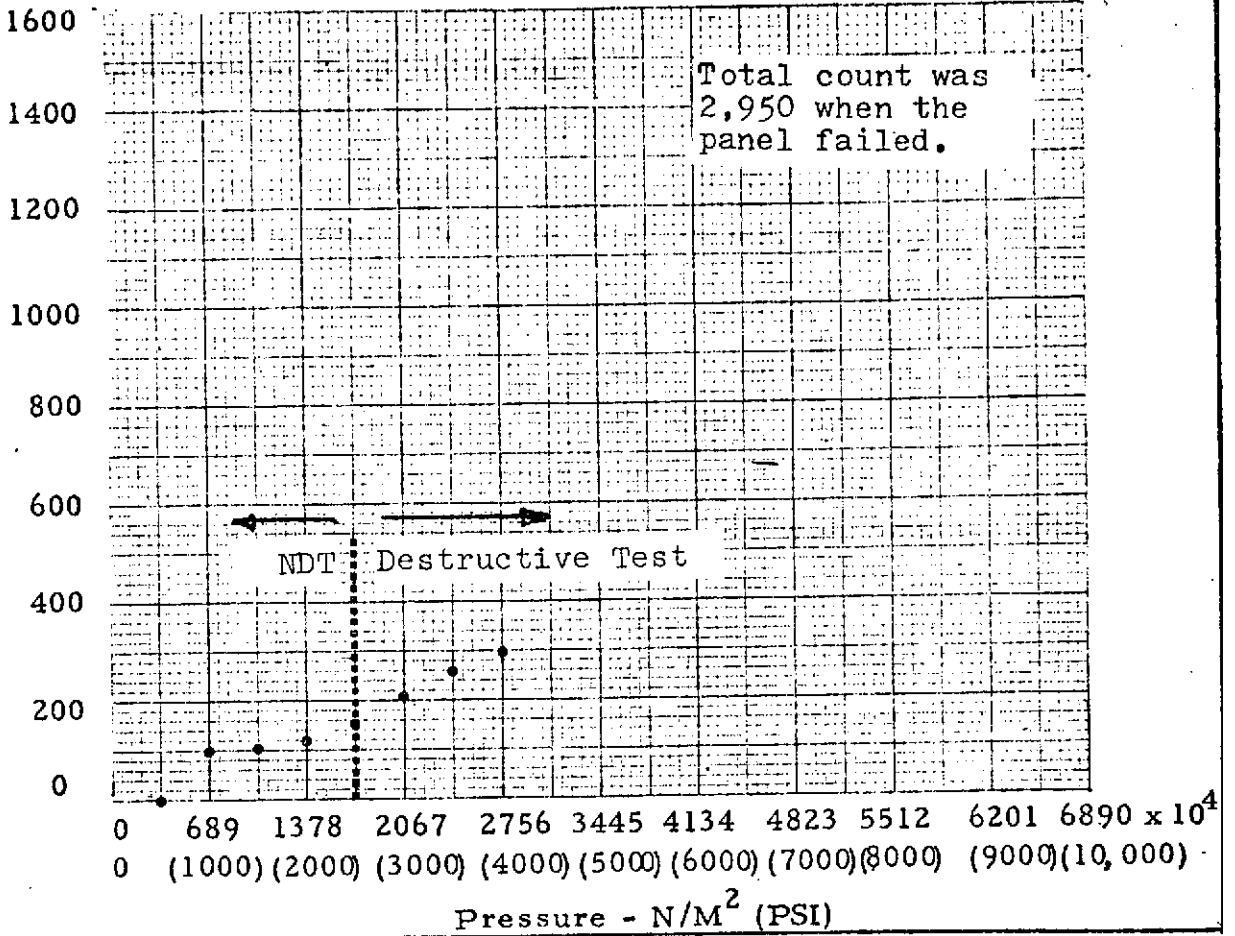


FIGURE C-26

Panel No. C-32N

Summation $\times 10^{-1}$

A E



HNDT (Before AE)

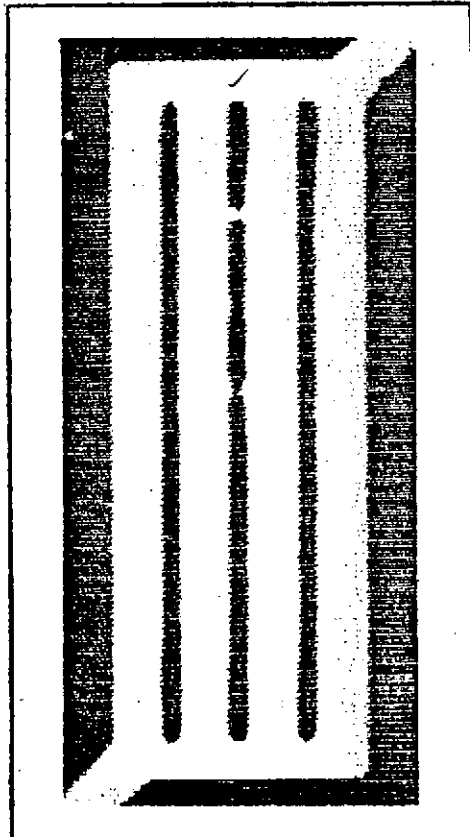


Press. $13.8 \times 10^5 N/M^2$
(200 PSI)

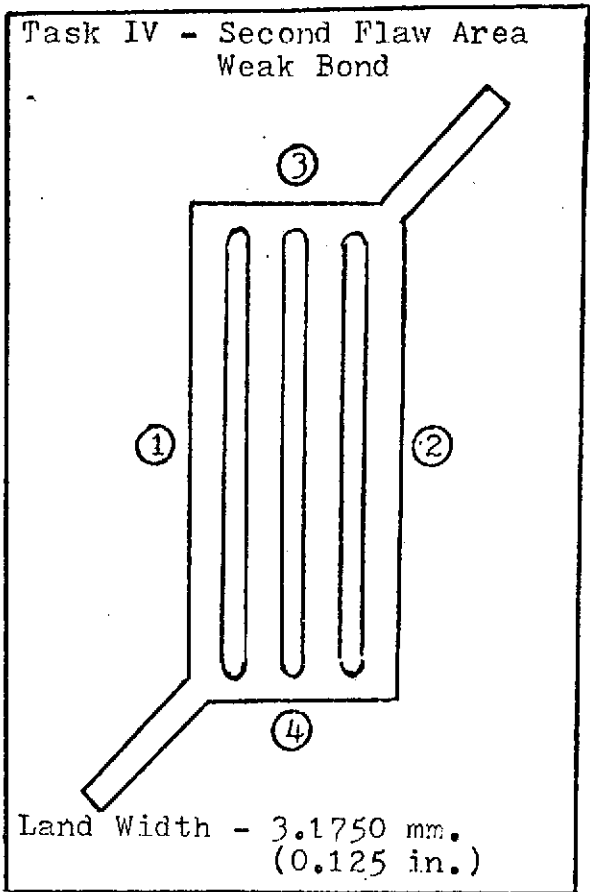
AE
FLAW LOCATOR
CENTER LAND



UT



ELECTROFORMED PANEL NO. C-33N



BASEPLATE

MATERIAL: OFHC Copper

CENTER LAND FLATNESS VARIATION:
0.0005 in. (0.0127 mm.)

THICKNESS:	MM.	INCHES
①	6.5938	0.2596
②	6.6142	0.2604
③	6.6065	0.2601
④	6.5862	0.2593

COVERPLATE

MATERIAL; Electroformed Nickel

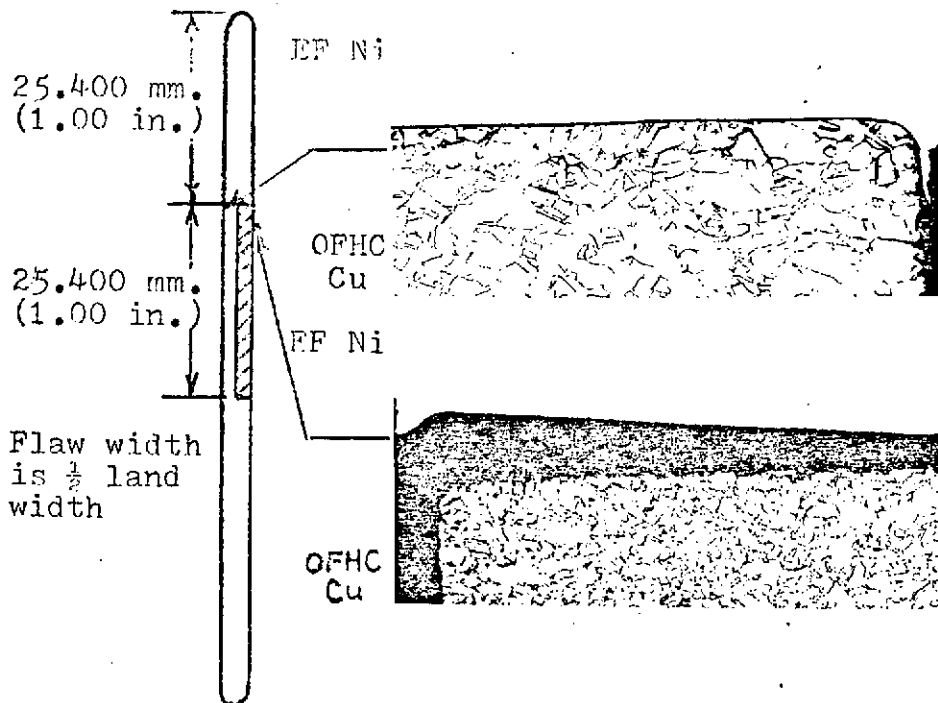
THICKNESS:	MM.	INCHES
①	0.8814	0.0347
②	0.8992	0.0354
③	0.8814	0.0347
④	0.9144	0.0360

PRESSURE REQUIRED TO FAIL BOND:

Bond failed at a pressure of
 $5.18 \times 10^7 \text{ N/m}^2$ (7,500 psi).

CENTER LAND DEFECT

METALLOGRAPHIC ANALYSIS:

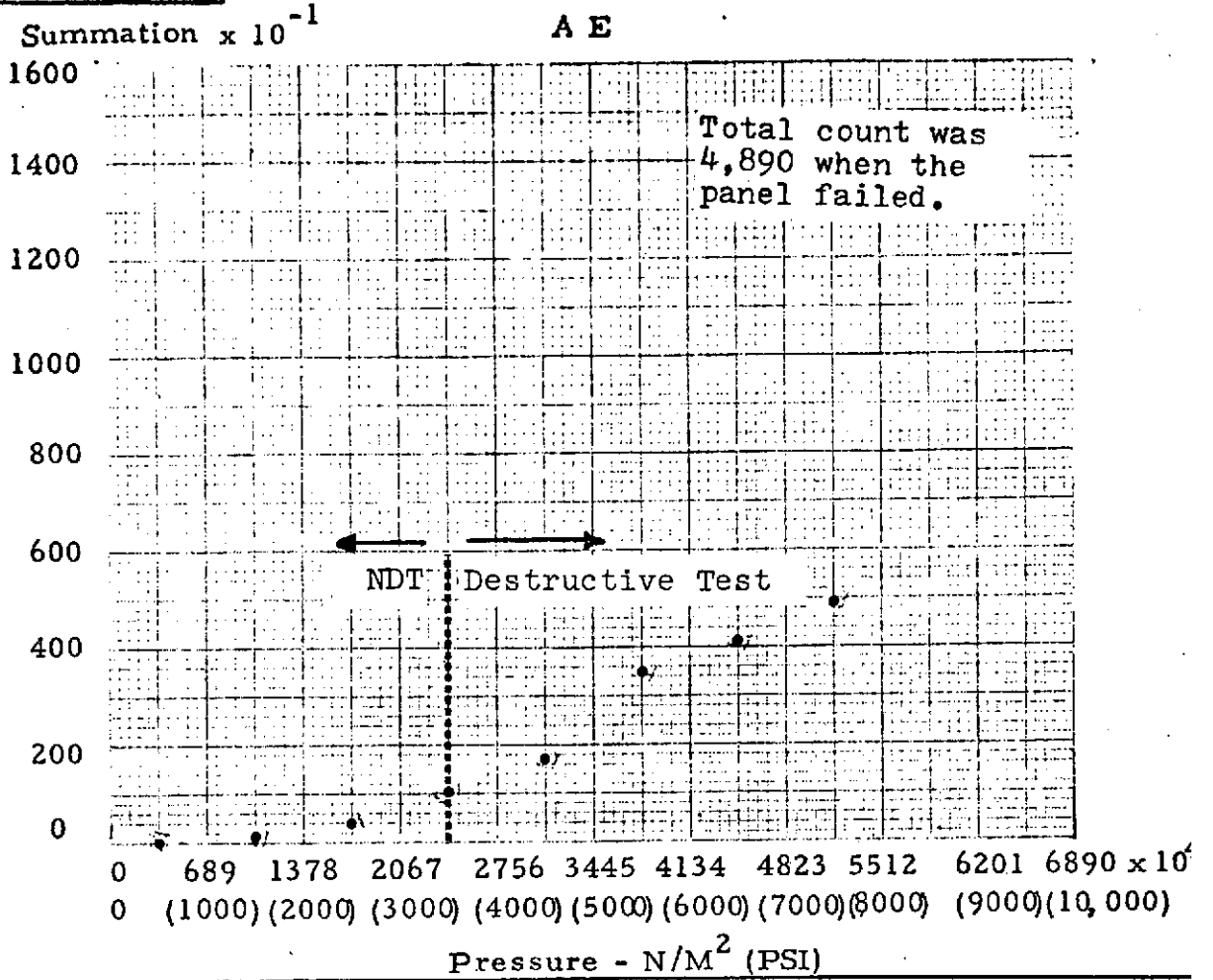


Full bond area next to planned weak bond. View appears reversed due to viewing direction. Magnification 50X.

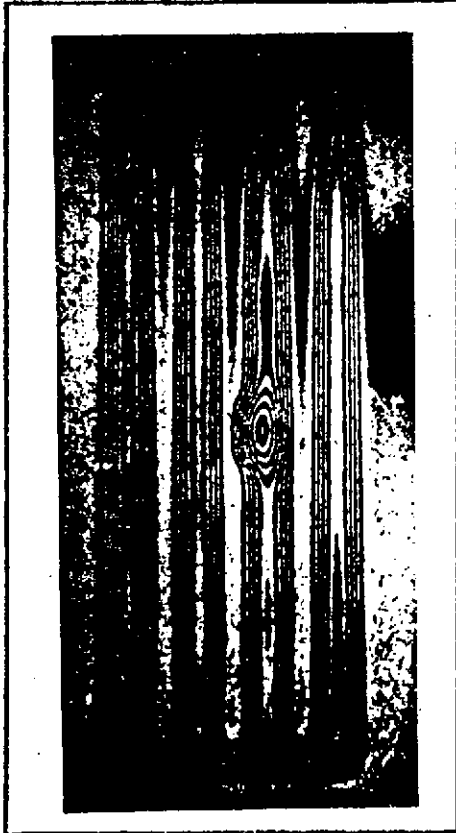
Planned weak bond showing bond failure. Section appears reversed due to direction of viewing. Magnification 50X.

FIGURE C-27

Panel No. C-33N

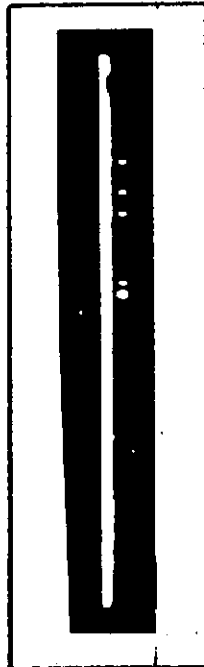


HNDT (Before AE)



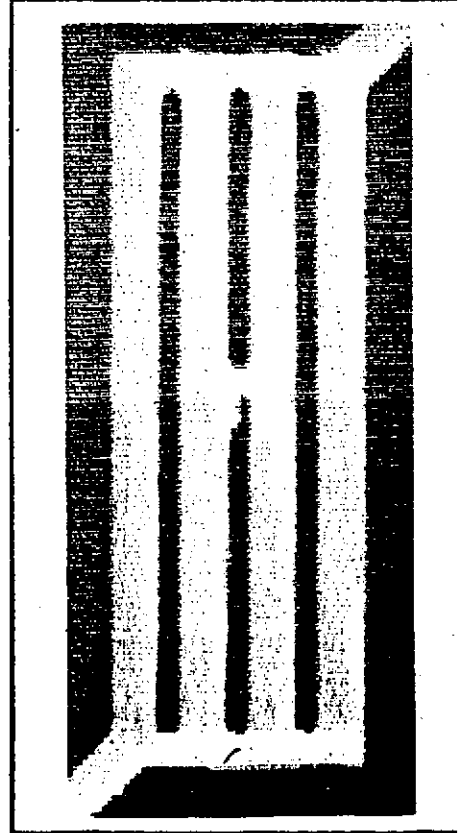
Press. - $20.7 \times 10^5 N/M^2$
(50 PSI)

AE
FLAW LOCATOR
CENTER LAND

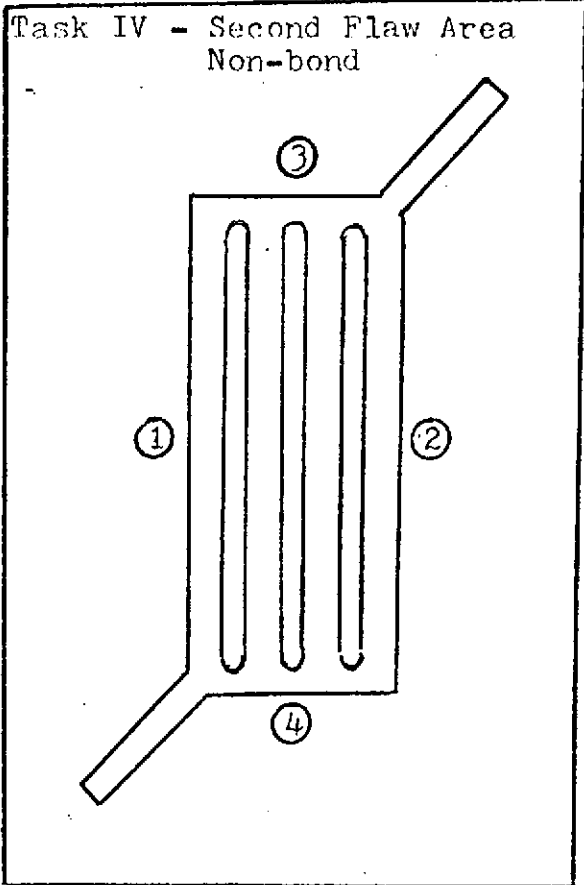


123

UT



ELECTROFORMED PANEL NO. C-34N



BASEPLATE

MATERIAL: OFHC Copper

CENTER LAND FLATNESS VARIATION:
0.0025 in. (0.0635 mm.)

THICKNESS:	MM.	INCHES
①	6.4846	0.2553
②	6.4821	0.2552
③	6.4541	0.2541
④	6.5126	0.2564

COVERPLATE

MATERIAL: Electroformed Nickel

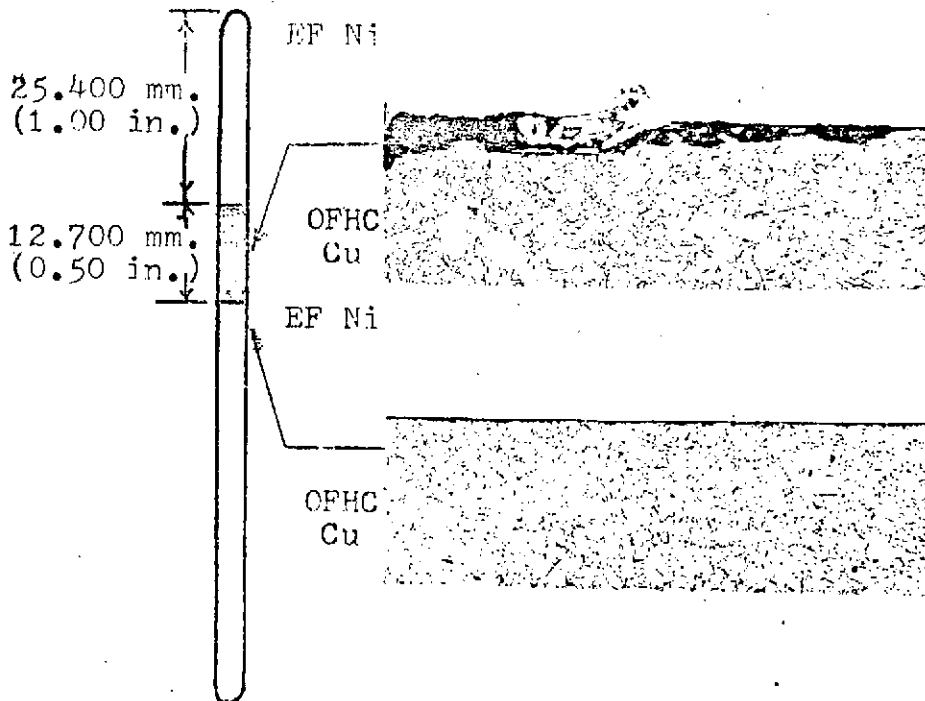
THICKNESS:	MM.	INCHES
①	0.9830	0.0387
②	0.9601	0.0378
③	1.0084	0.0397
④	0.9296	0.0366

PRESSURE REQUIRED TO FAIL BOND:

Panel failed at a pressure of
 $3.11 \times 10^7 \text{ N/m}^2$ (4,500 psi).

CENTER LAND DEFECT

METALLOGRAPHIC ANALYSIS:

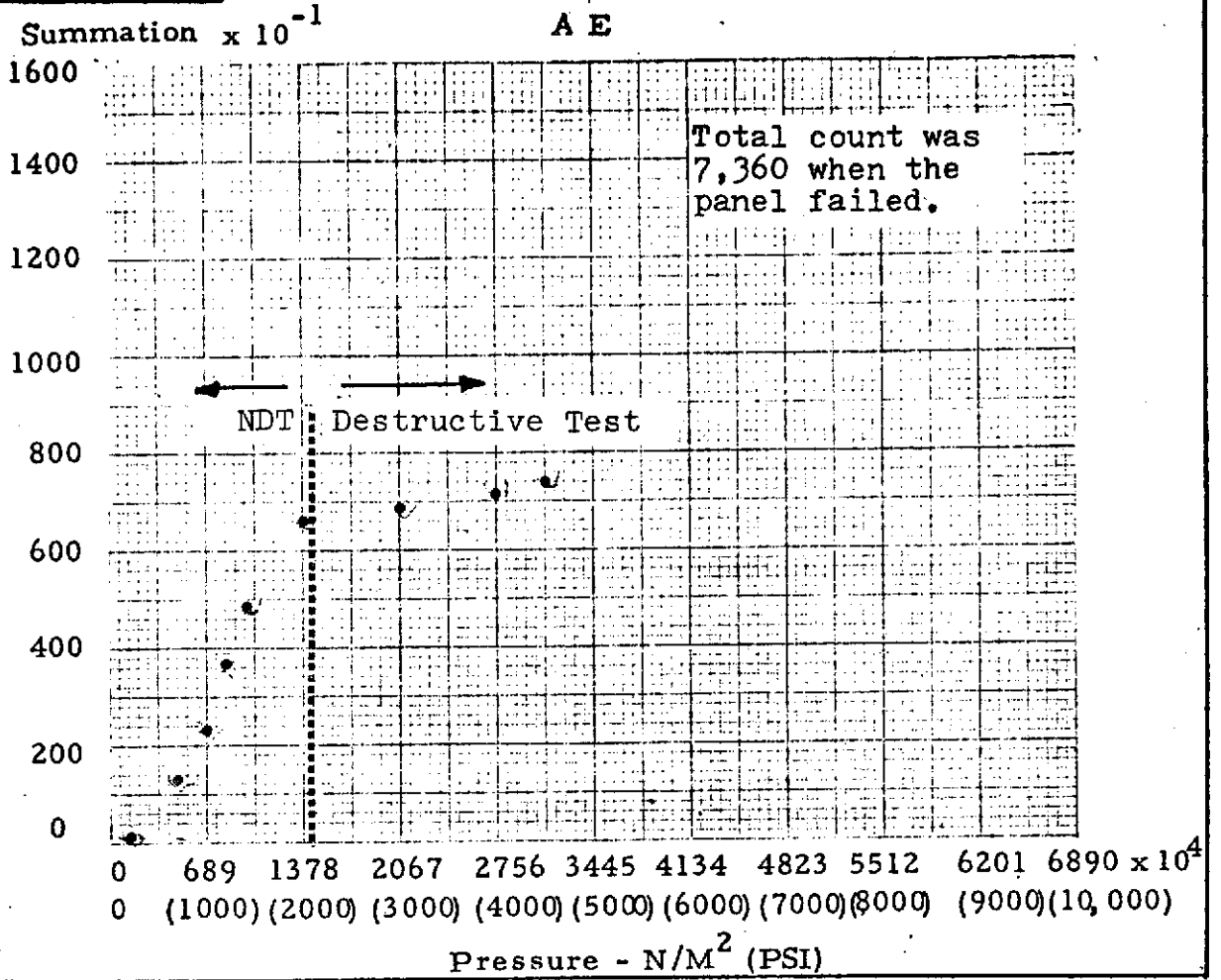


Section showing separation of the planned nonbond. Some full bond failed beyond the end of the nonbond. Magnification 50X.

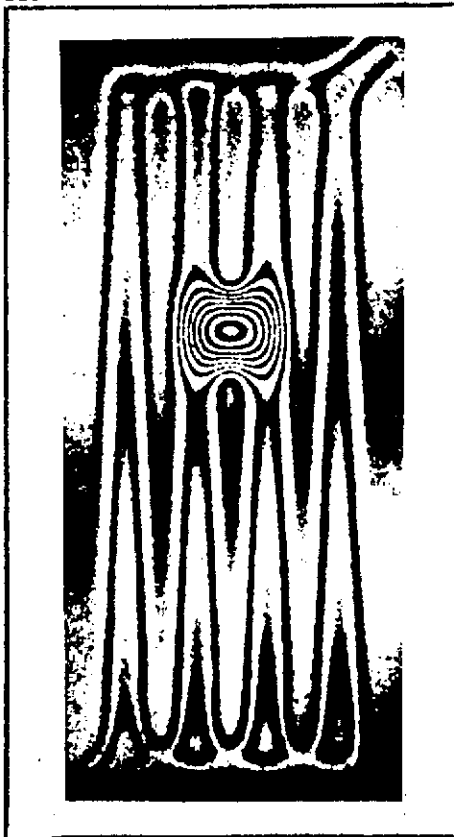
Section of full bond from the middle land which exhibited no failure. Magnification 50X.

FIGURE C-28

Panel No. C-34N

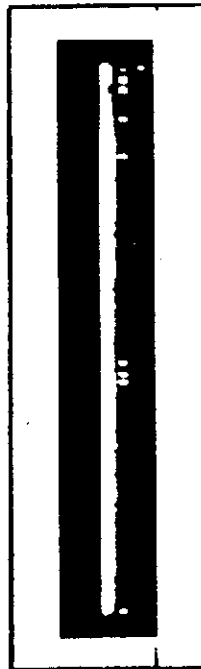


HNDT (Before AE)



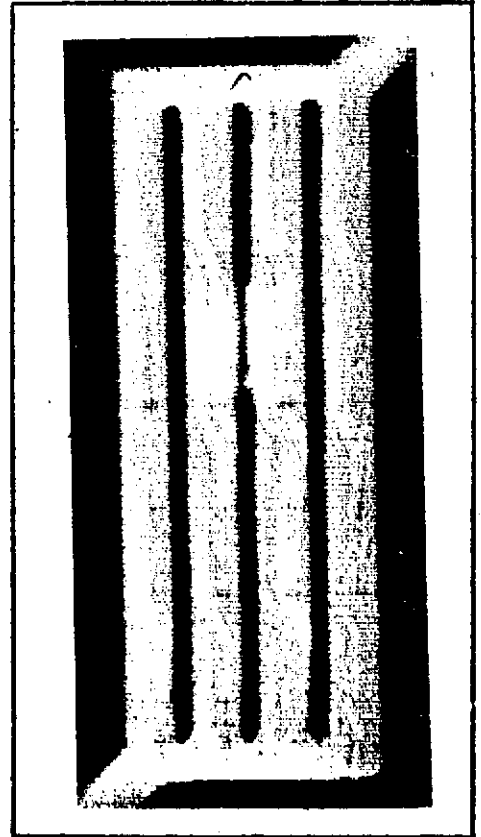
Press. - 3.45×10^5 N/M^2
(50 PSI)

AE
FLAW LOCATOR
CENTER LAND

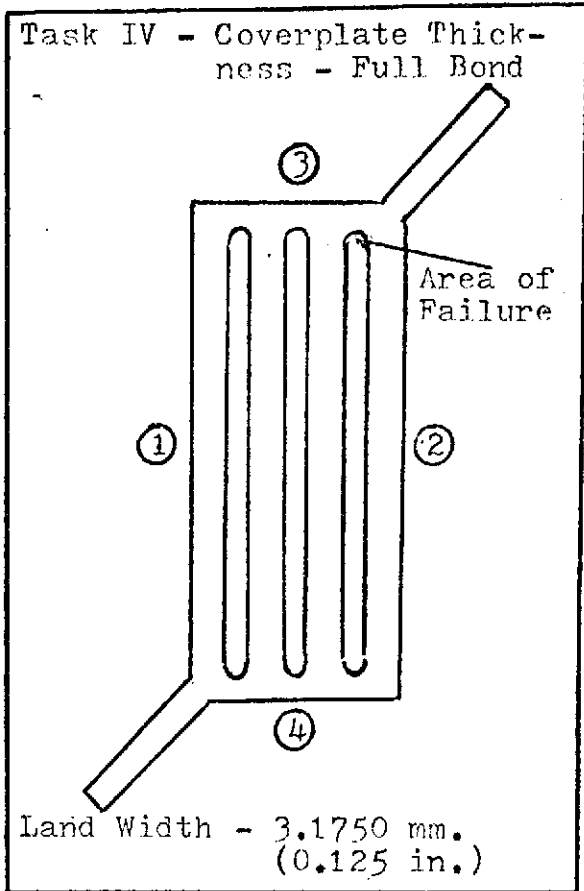


125

UT



ELECTROFORMED PANEL NO. C-09N



BASEPLATE

MATERIAL: OFHC Copper

CENTER LAND FLATNESS VARIATION:
0.002 in. (0.0508 mm.)

THICKNESS:	MM.	INCHES
①	6.6726	0.2627
②	6.6751	0.2628
③	6.6548	0.2620
④	6.6548	0.2620

COVERPLATE

MATERIAL: Electroformed Nickel

THICKNESS:	MM.	INCHES
①	0.6985	0.0275
②	0.6833	0.0269
③	0.7671	0.0302
④	0.6807	0.0268

PRESSURE REQUIRED TO FAIL BOND:

Bond failed at a pressure of
 3.45×10^7 N/m² (5,000 psi).

CENTER LAND DEFECT

METALLOGRAPHIC ANALYSIS:

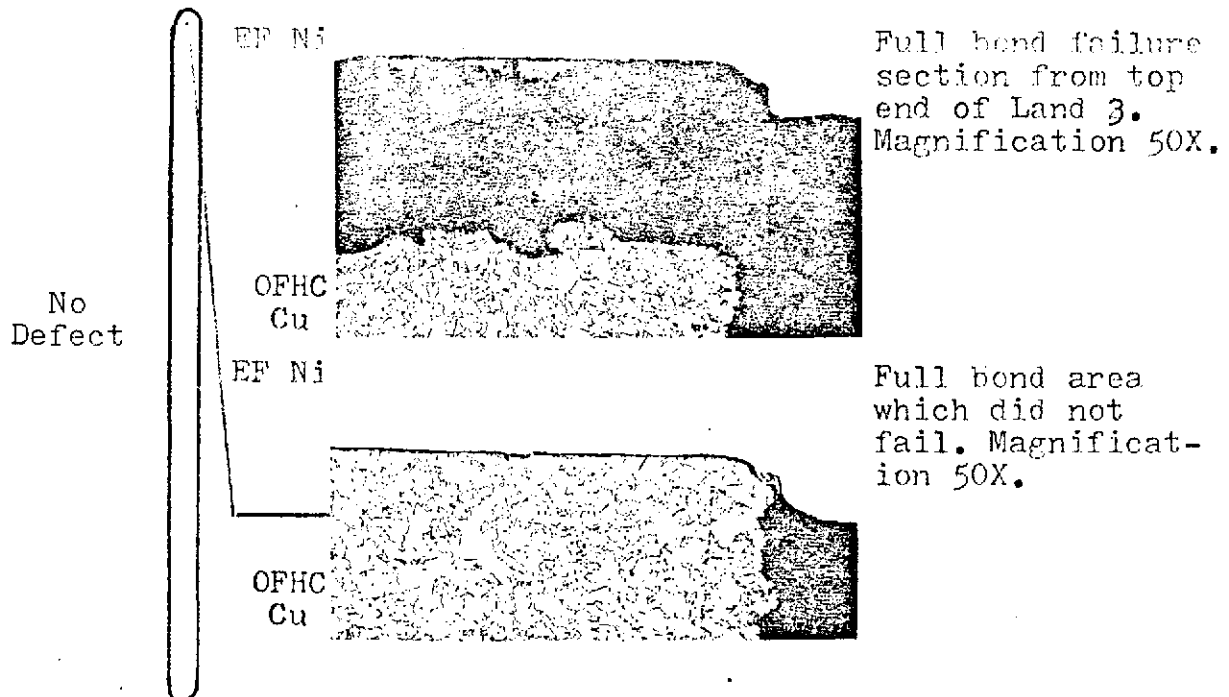
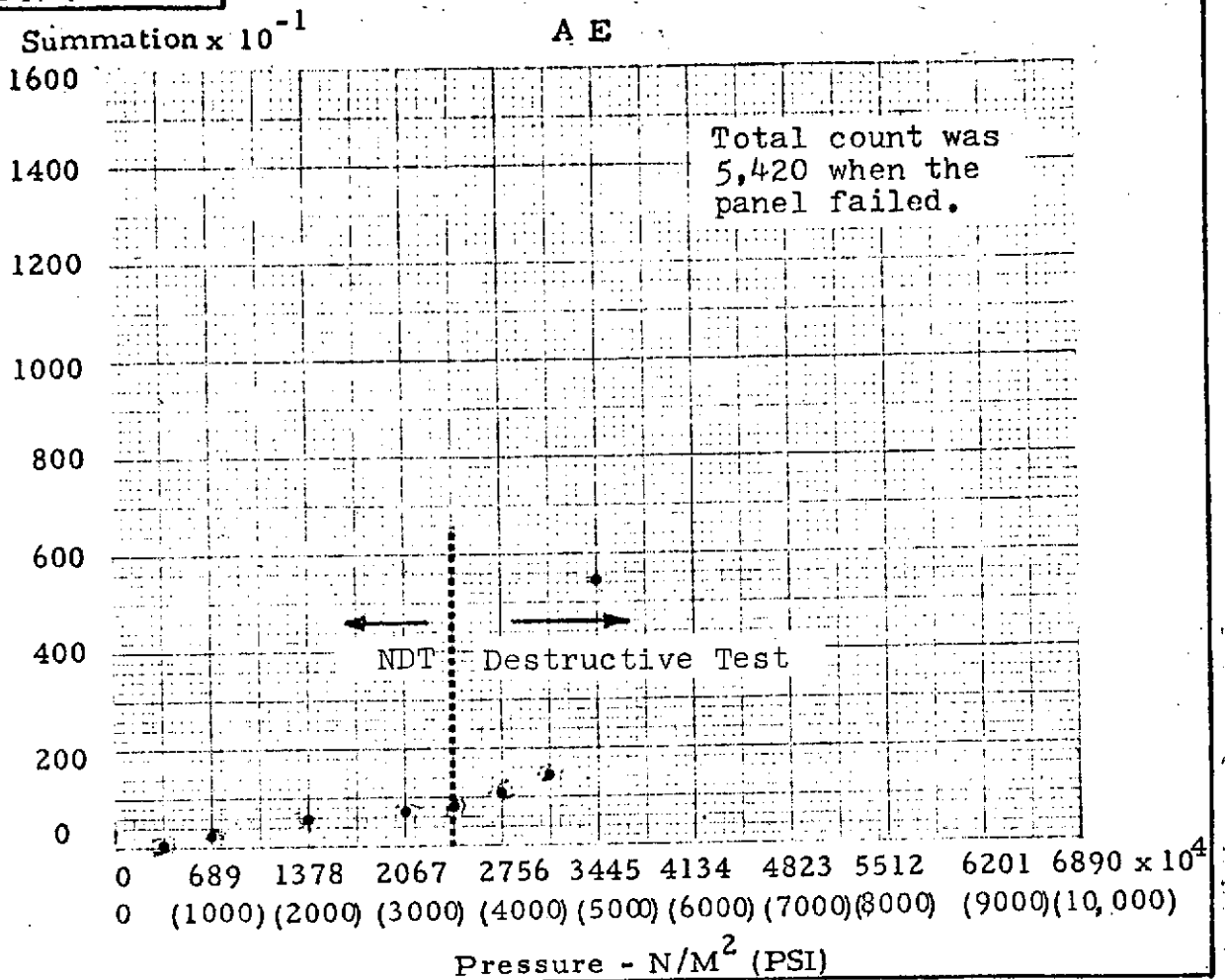


FIGURE C-29

Panel No. C-9N

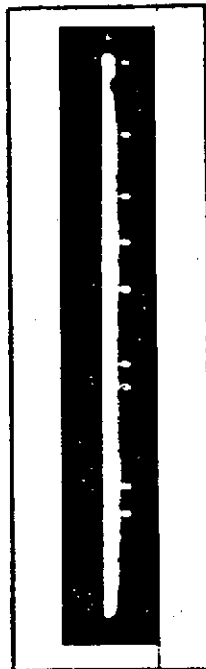


HNDT (Before AE)



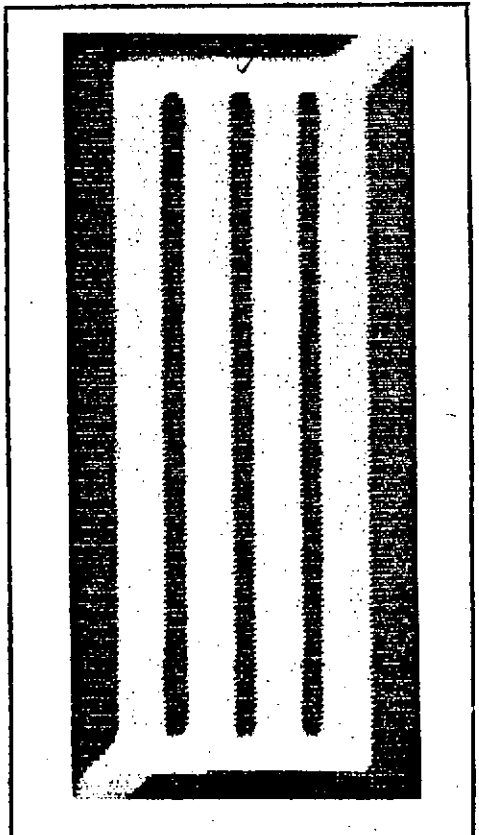
Press. - $20.7 \times 10^5 N/M^2$
(300 PSI)

AE
FLAW LOCATOR
CENTER LAND

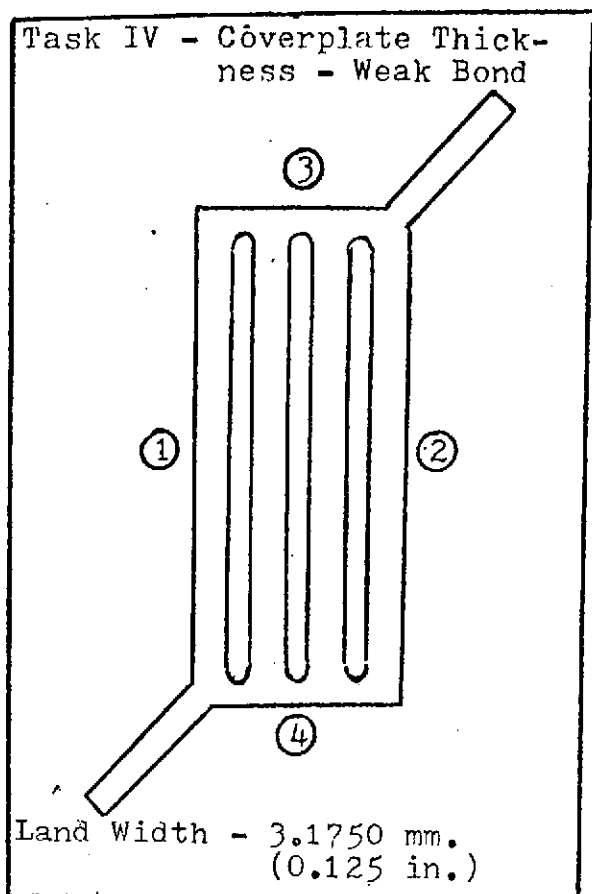


127

UT



ELECTROFORMED PANEL NO. C-35N "A"



BASEPLATE

MATERIAL: OFHC Copper
CENTER LAND FLATNESS VARIATION:
'0.0025 in. (0.0635 mm.)

THICKNESS:	MM.	INCHES
①	6.5100	0.2563
②	6.5227	0.2568
③	6.5659	0.2585
④	6.5354	0.2573

COVERPLATE

MATERIAL: Electroformed Nickel

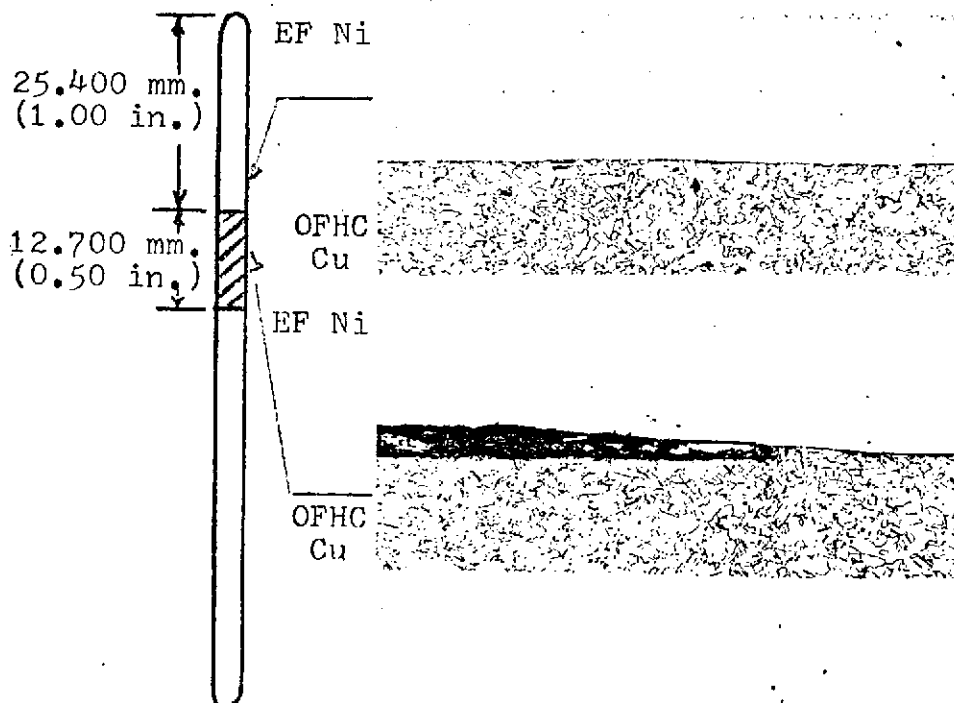
THICKNESS:	MM.	INCHES
①	0.6452	0.0254
②	0.6731	0.0265
③	0.6401	0.0252
④	0.5918	0.0233

PRESSURE REQUIRED TO FAIL BOND:

Bond failed at a pressure of
 $2.42 \times 10^7 \text{ N/m}^2$ (3,500 psi).

CENTER LAND DEFECT

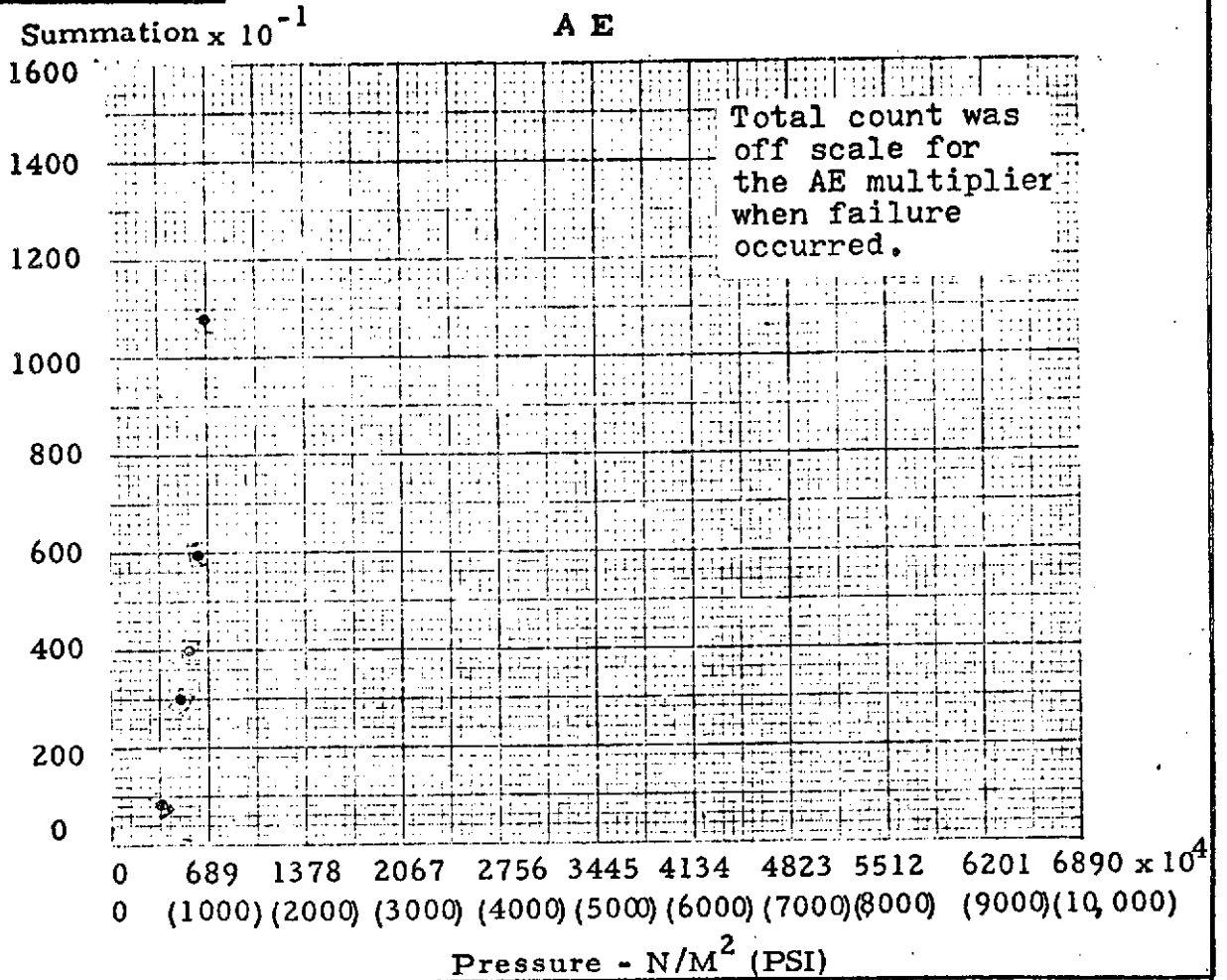
METALLOGRAPHIC ANALYSIS:



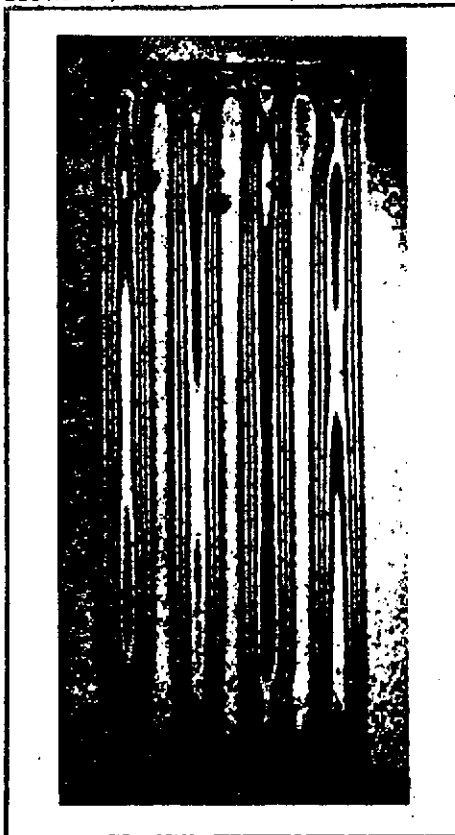
Planned full bond
showing no fail-
ure after destruct-
ive test.
Magnification 50X.

Planned weak bond
which failed in
destructive test.
Magnification 50X.

FIGURE C-30

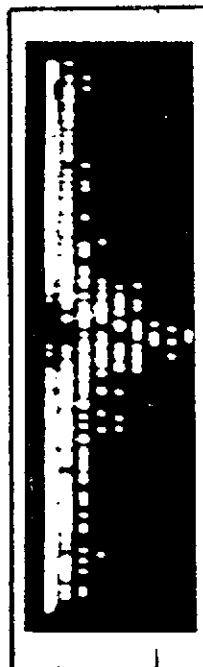


HNDT (Before AE)



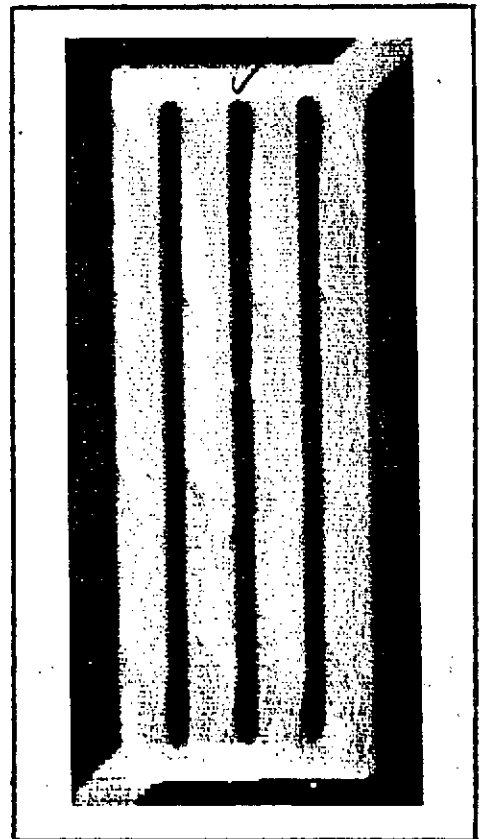
Press. 6.9×10^5 N/M^2
(100 PSI)

AE
FLAW LOCATOR
CENTER LAND

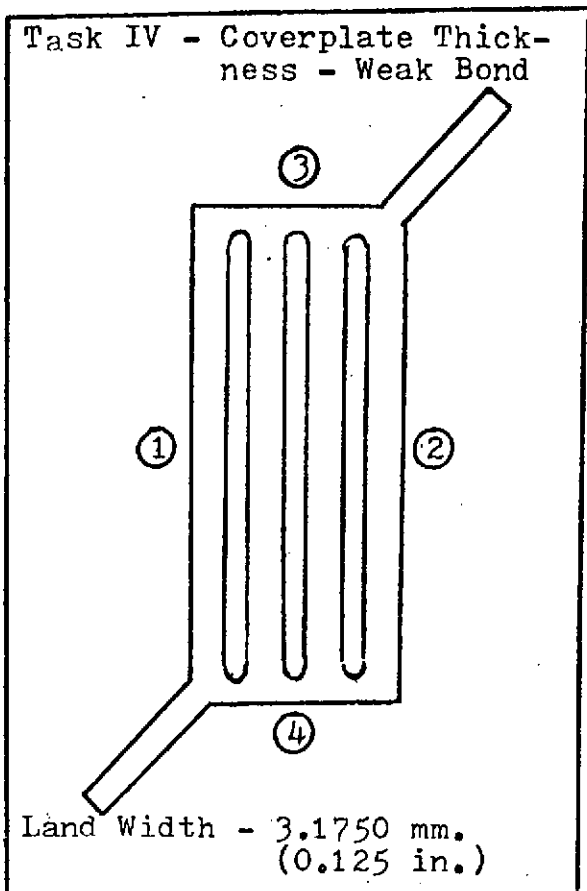


After NDE and
Destructive Test

UT



ELECTROFORMED PANEL NO. C-36N "A"



BASEPLATE

MATERIAL: OFHC Copper

CENTER LAND FLATNESS VARIATION:
0.006 in. (0.1524 mm.)

THICKNESS:	MM.	INCHES
①	6.3551	0.2502
②	6.3094	0.2484
③	6.3754	0.2510
④	6.3703	0.2508

COVERPLATE

MATERIAL: Electroformed Nickel

THICKNESS:	MM.	INCHES
①	0.7925	0.0312
②	0.8306	0.0327
③	0.7239	0.0285
④	0.7391	0.0291

PRESSURE REQUIRED TO FAIL BOND:

Panel failed at a pressure of
 $1.86 \times 10^7 \text{ N/m}^2$ (2,700 psi).

CENTER LAND DEFECT

METALLOGRAPHIC ANALYSIS:

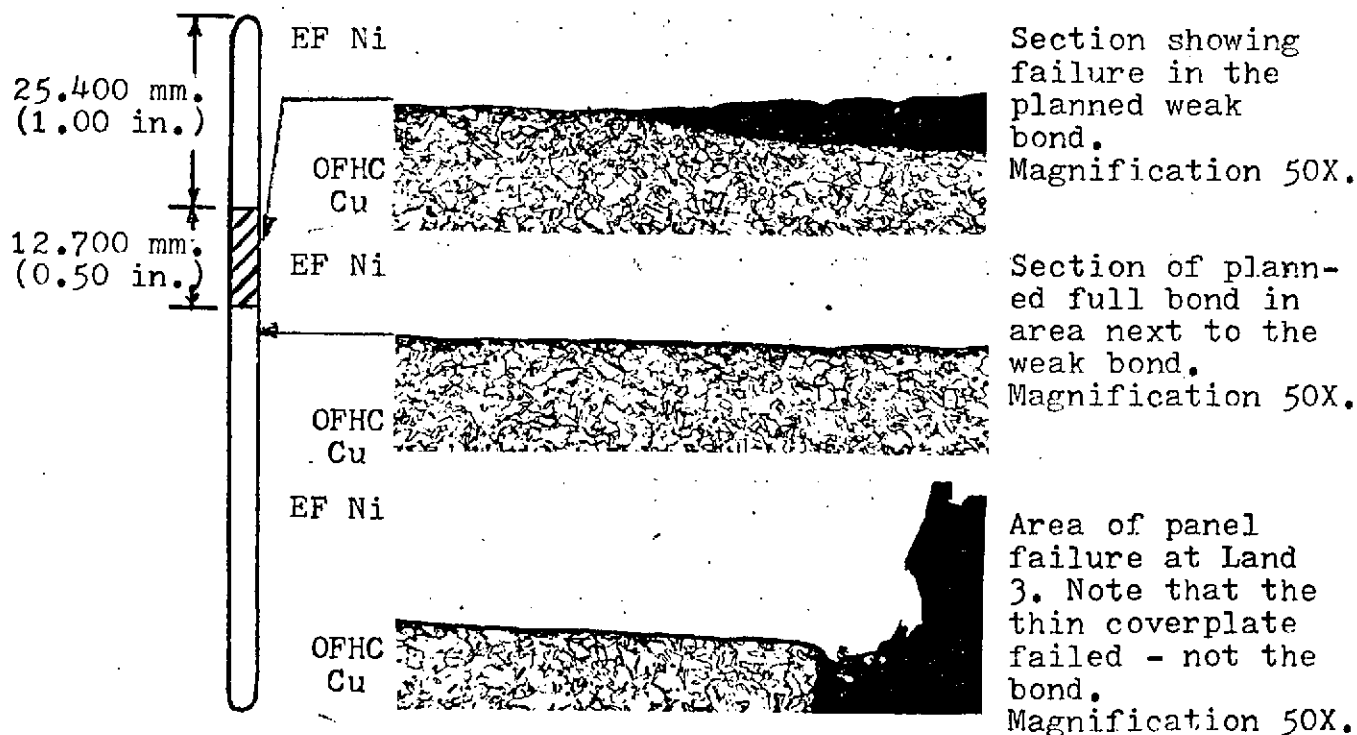
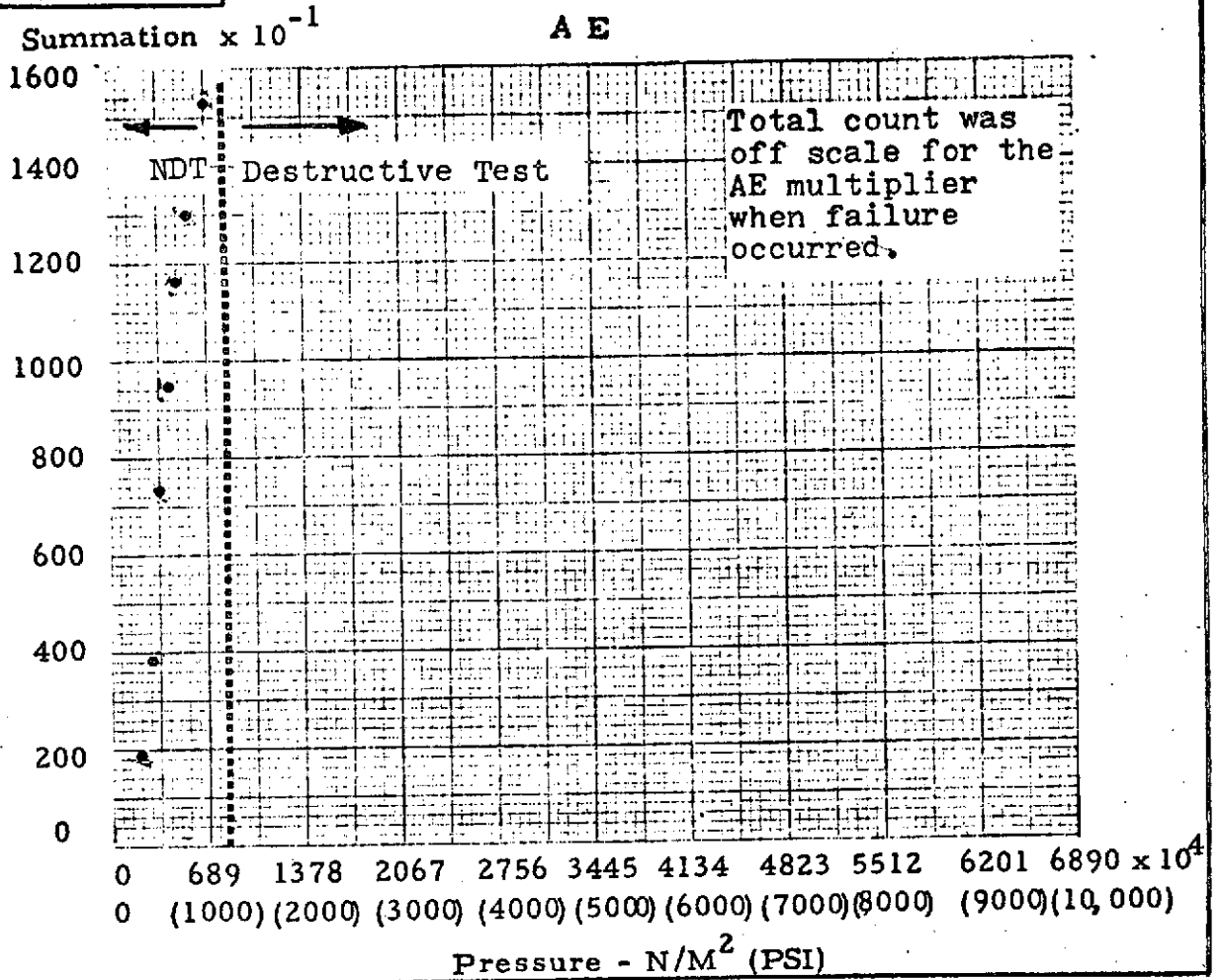


FIGURE C-31

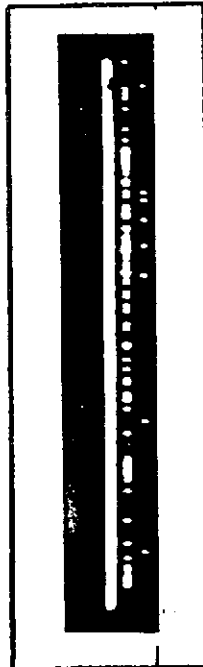
Panel No. C-36N



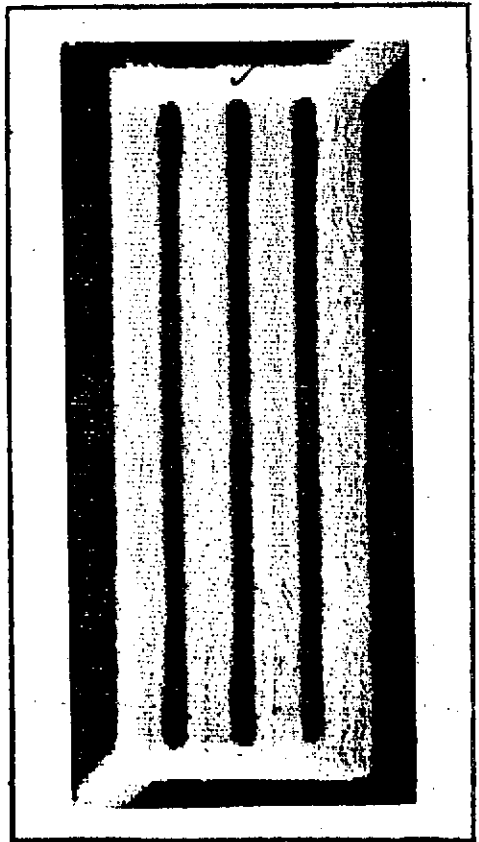
HNDT (Before AE)



AE
FLAW LOCATOR
CENTER LAND

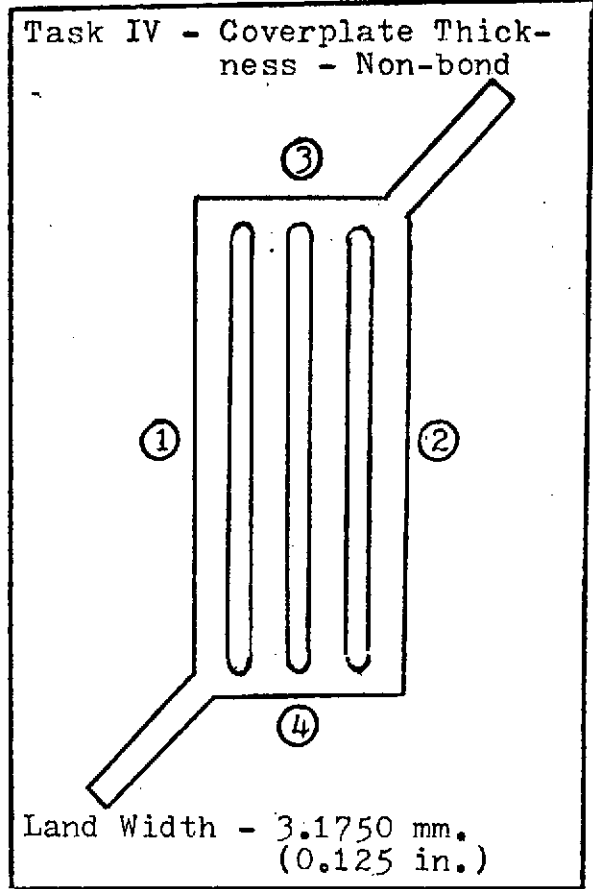


UT



Press. 10.4×10^5 N/M^2
(150 PSI)

ELECTROFORMED PANEL NO. C-37N



BASEPLATE

MATERIAL: OFHC Copper

CENTER LAND FLATNESS VARIATION:
0.0035 in. (0.0889 mm.)

THICKNESS:	MM.	INCHES
①	6.4186	0.2527
②	6.4643	0.2545
③	6.4745	0.2549
④	6.3983	0.2519

COVERPLATE

MATERIAL: Electroformed Nickel

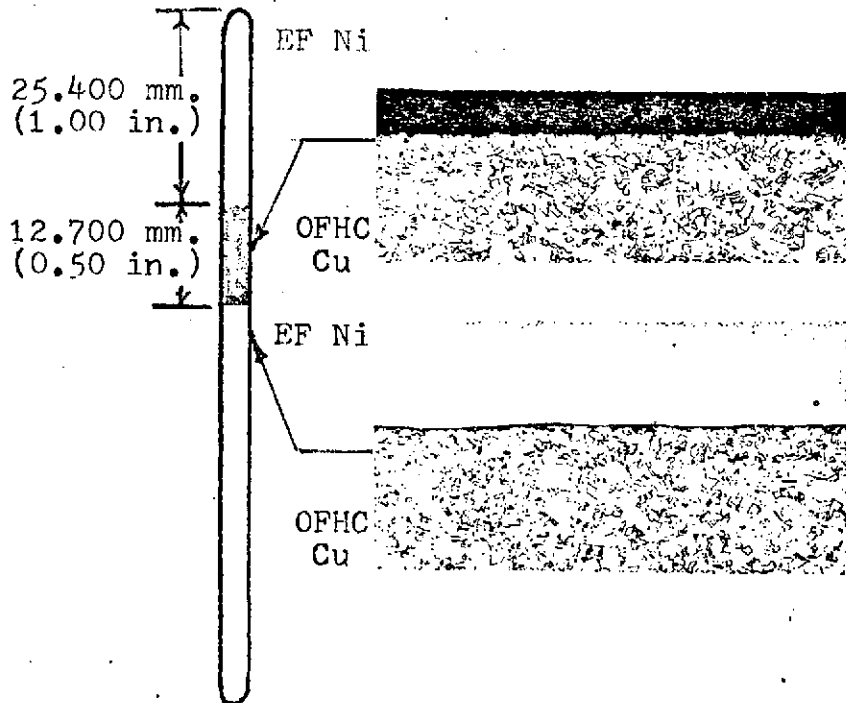
THICKNESS:	MM.	INCHES
①	0.7518	0.0296
②	0.6782	0.0267
③	0.6502	0.0256
④	0.7823	0.0308

PRESSURE REQUIRED TO FAIL BOND:

Bond failed at a pressure of
 $1.86 \times 10^7 \text{ N/m}^2$ (2,700 psi).

CENTER LAND DEFECT

METALLOGRAPHIC ANALYSIS:

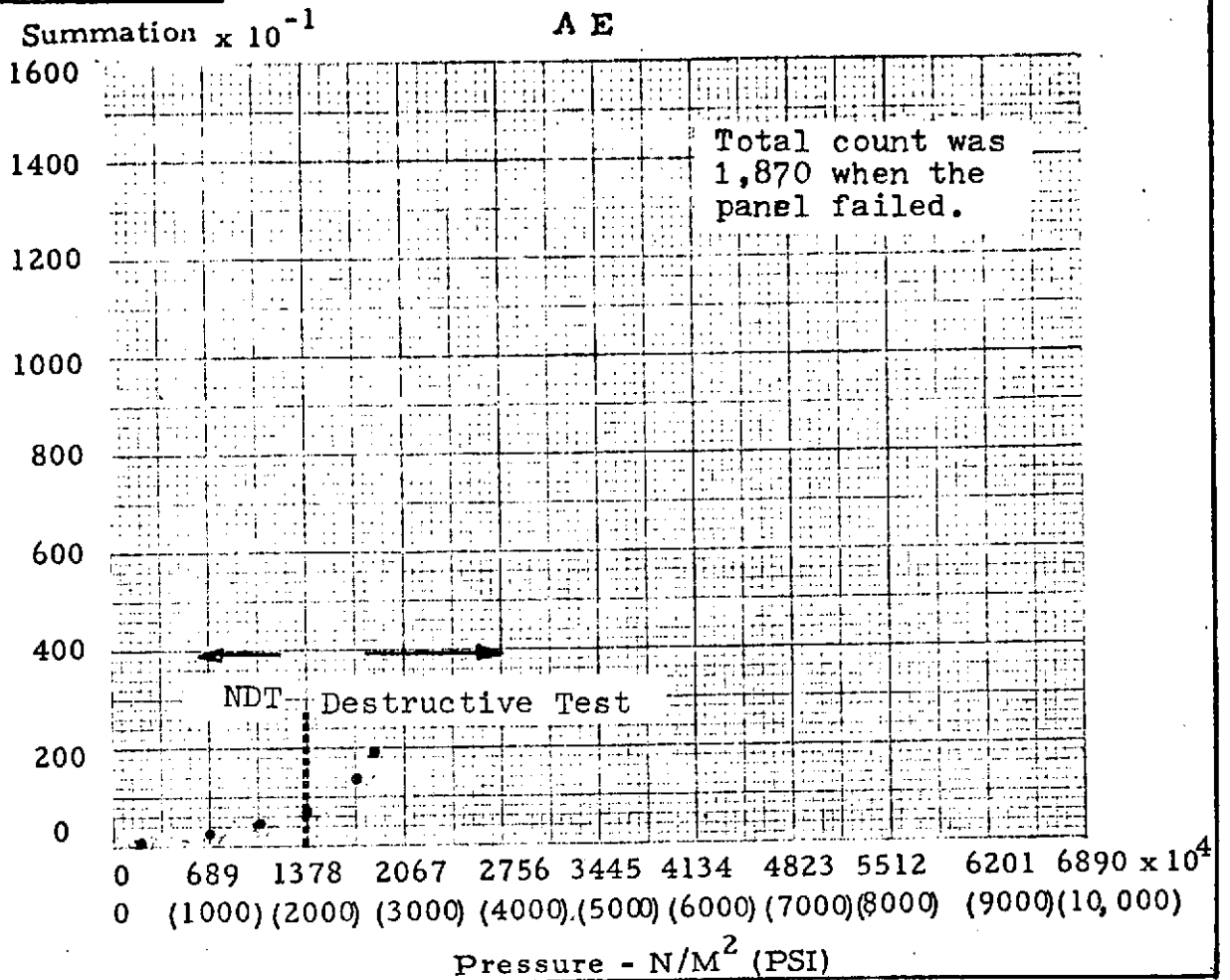


Section showing nonbond separation. Magnification 50X.

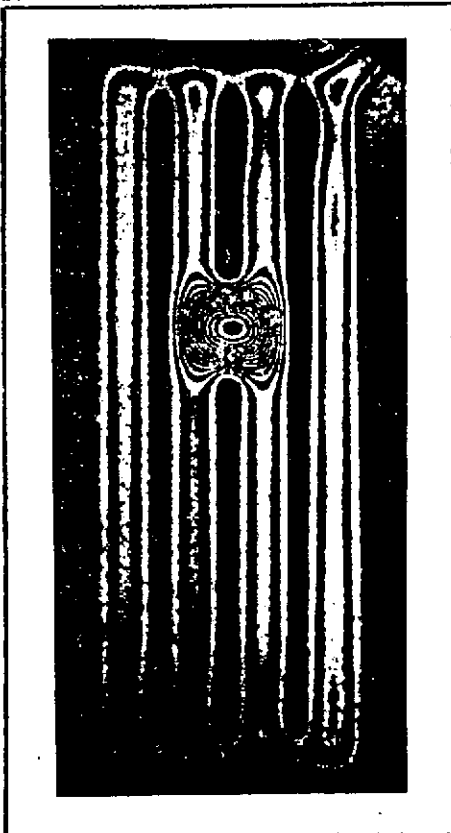
Section showing full bond adjacent to the planned nonbond. Magnification 50X.

FIGURE C-32

Panel No. C-37N



HNDT (Before AE)



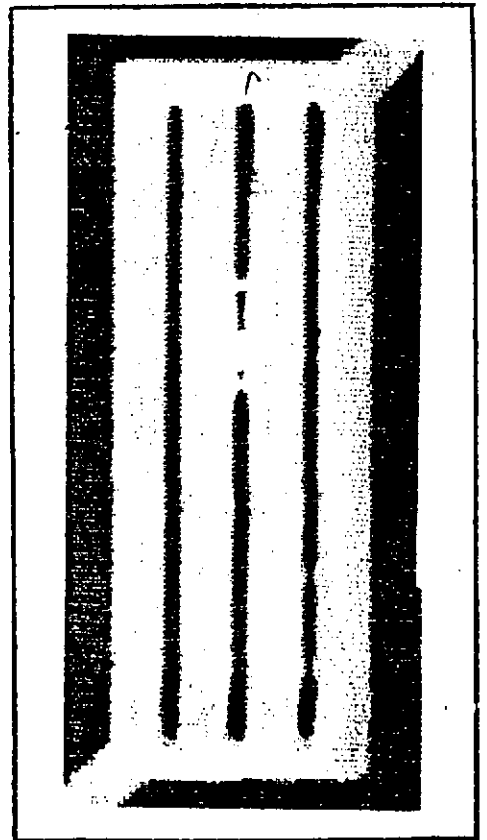
Press. - $3.45 \times 10^5 N/M^2$
(50 PSI)

AE
FLAW LOCATOR
CENTER LAND

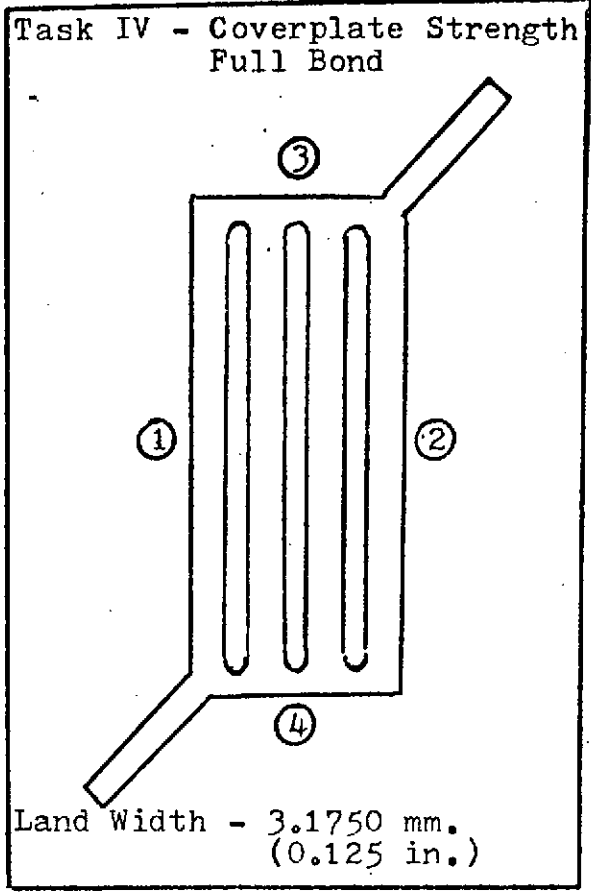


133

UT



ELECTROFORMED PANEL NO. C-06N



BASEPLATE

MATERIAL: OFHC Copper

CENTER LAND FLATNESS VARIATION:
0.002 in. (0.0508 mm.)

THICKNESS:	MM.	INCHES
①	6.5481	0.2578
②	6.5405	0.2575
③	6.6091	0.2602
④	6.4973	0.2558

COVERPLATE

MATERIAL: Electroformed Nickel

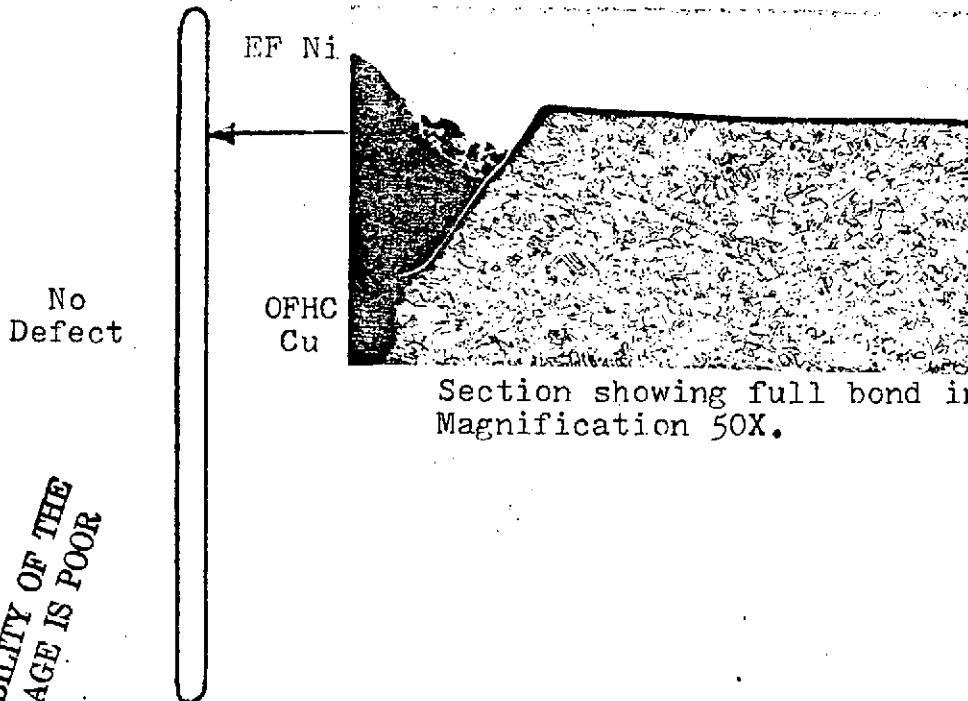
THICKNESS:	MM.	INCHES
①	0.9754	0.0384
②	0.9754	0.0384
③	0.9296	0.0366
④	1.0439	0.0411

PRESSURE REQUIRED TO FAIL BOND:

Panel did not fail at a pressure of 6.90×10^7 N/m² (10,000 psi). Slight coverplate deformation at the channels occurred.

CENTER LAND DEFECT

METALLOGRAPHIC ANALYSIS:

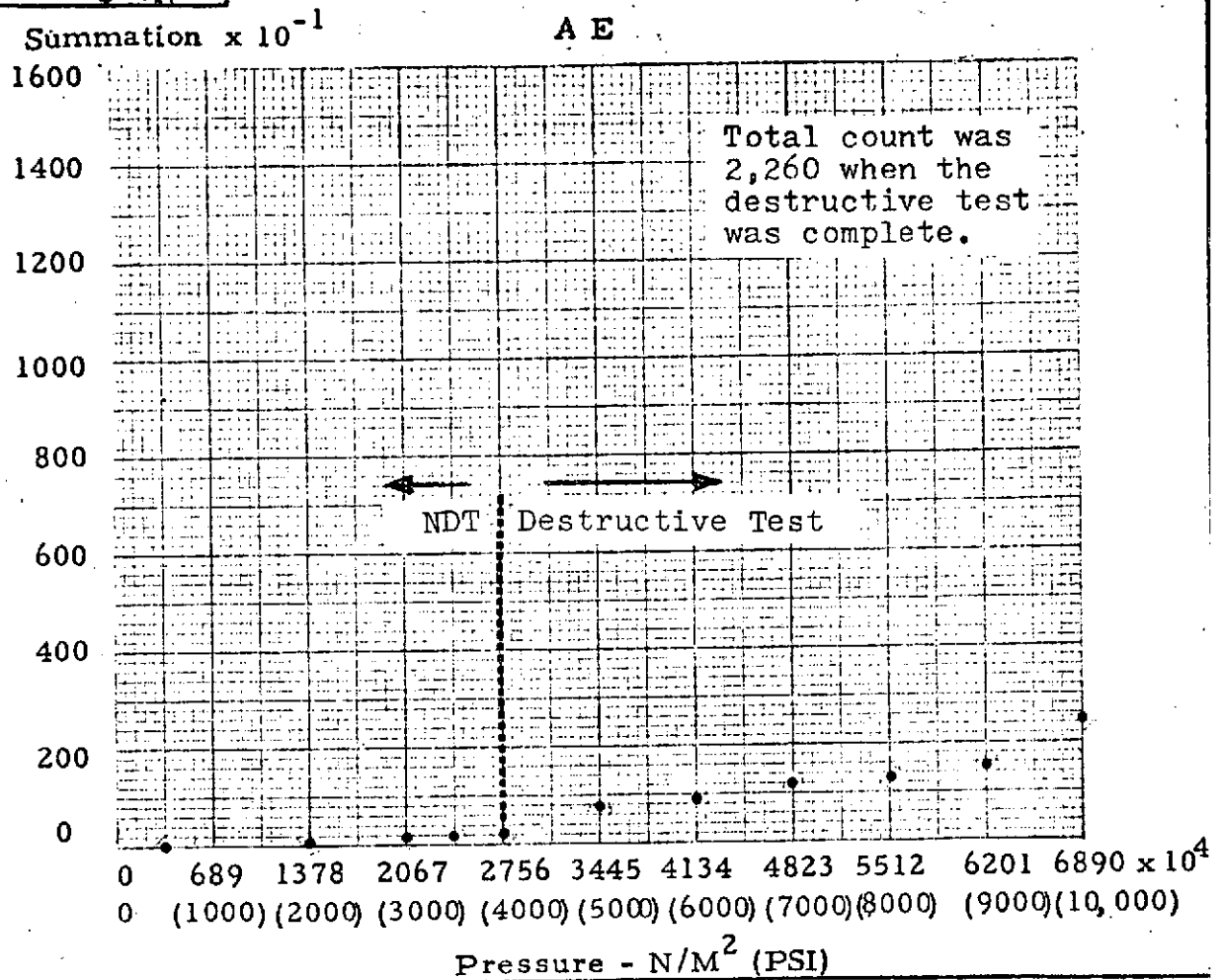


Section showing full bond intact.
Magnification 50X.

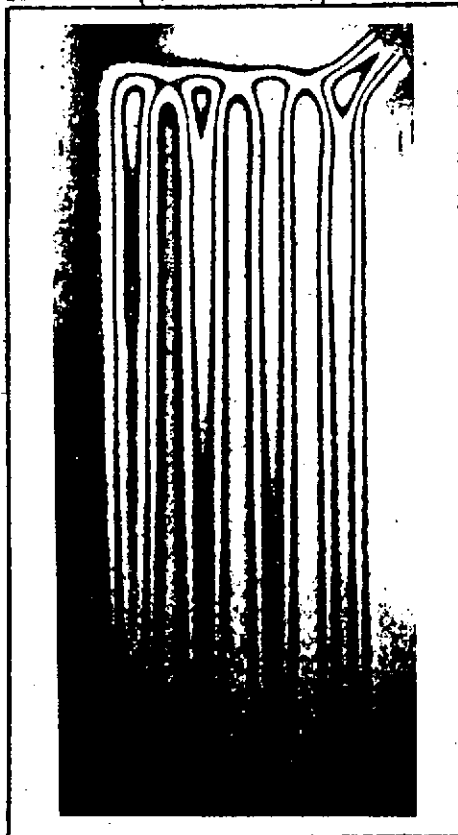
REPRODUCIBILITY OF THE ORIGINAL PAGE IS POOR

FIGURE C-33

Panel No. C-6N



HNDT (Before AE)

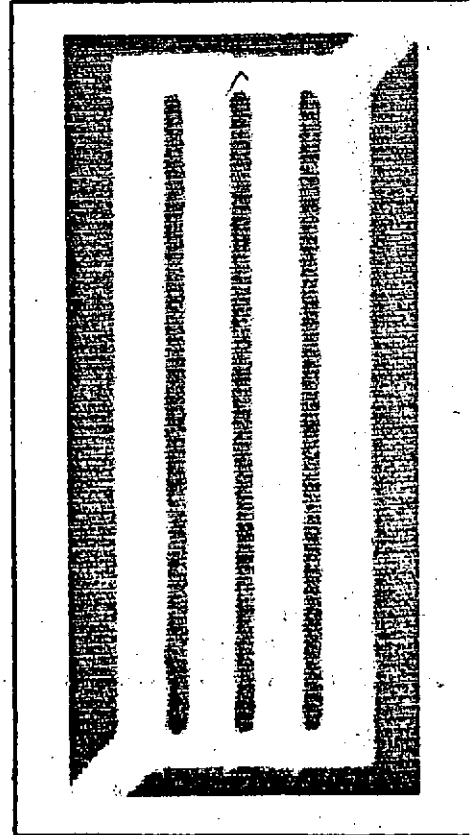


Press. $13.8 \times 10^5 N/M^2$
(200 PSI)

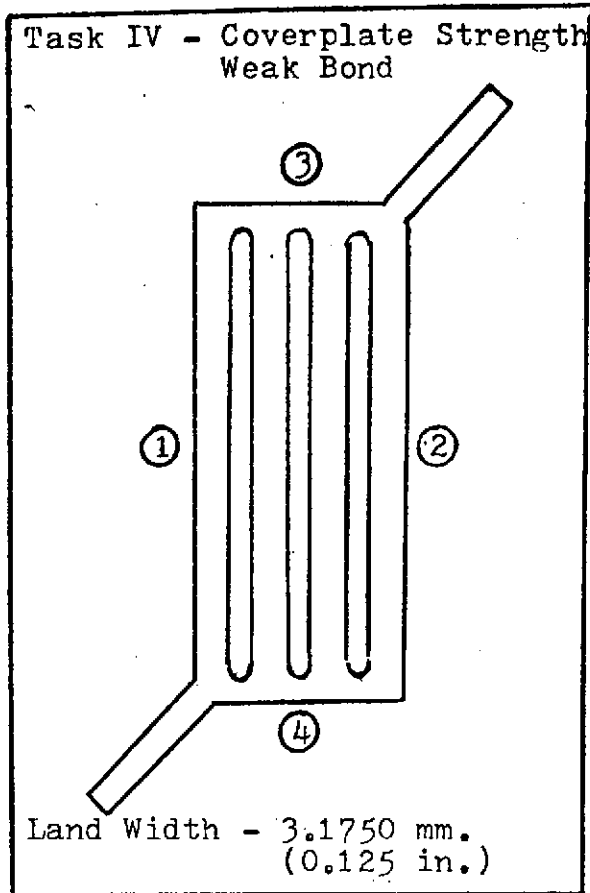
AE
FLAW LOCATOR
CENTER LAND



UT



ELECTROFORMED PANEL NO. C-38N



BASEPLATE

MATERIAL: OFHC Copper
CENTER LAND FLATNESS VARIATION:
0.0035 in. (0.0889 mm.)

THICKNESS:	MM.	INCHES
①	6.5532	0.2580
②	6.5938	0.2596
③	6.5303	0.2571
④	6.5964	0.2597

COVERPLATE

MATERIAL: Electroformed Nickel

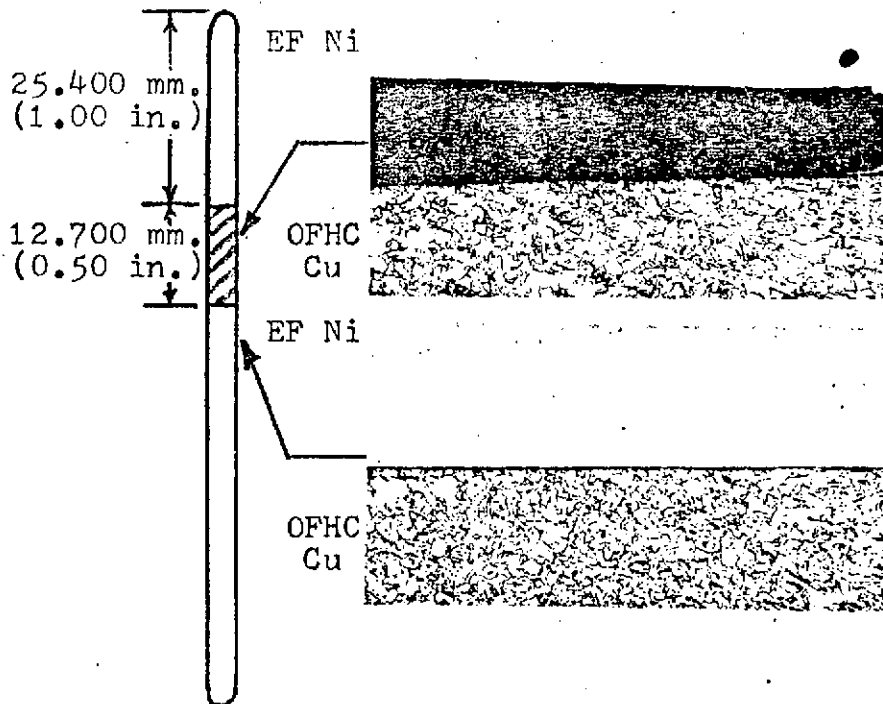
THICKNESS:	MM.	INCHES
①	0.9449	0.0372
②	0.9347	0.0368
③	0.9855	0.0388
④	0.8915	0.0351

PRESSURE REQUIRED TO FAIL BOND:

Bond failed at a pressure of
 3.45×10^7 N/m² (5,000 psi).

CENTER LAND DEFECT

METALLOGRAPHIC ANALYSIS:

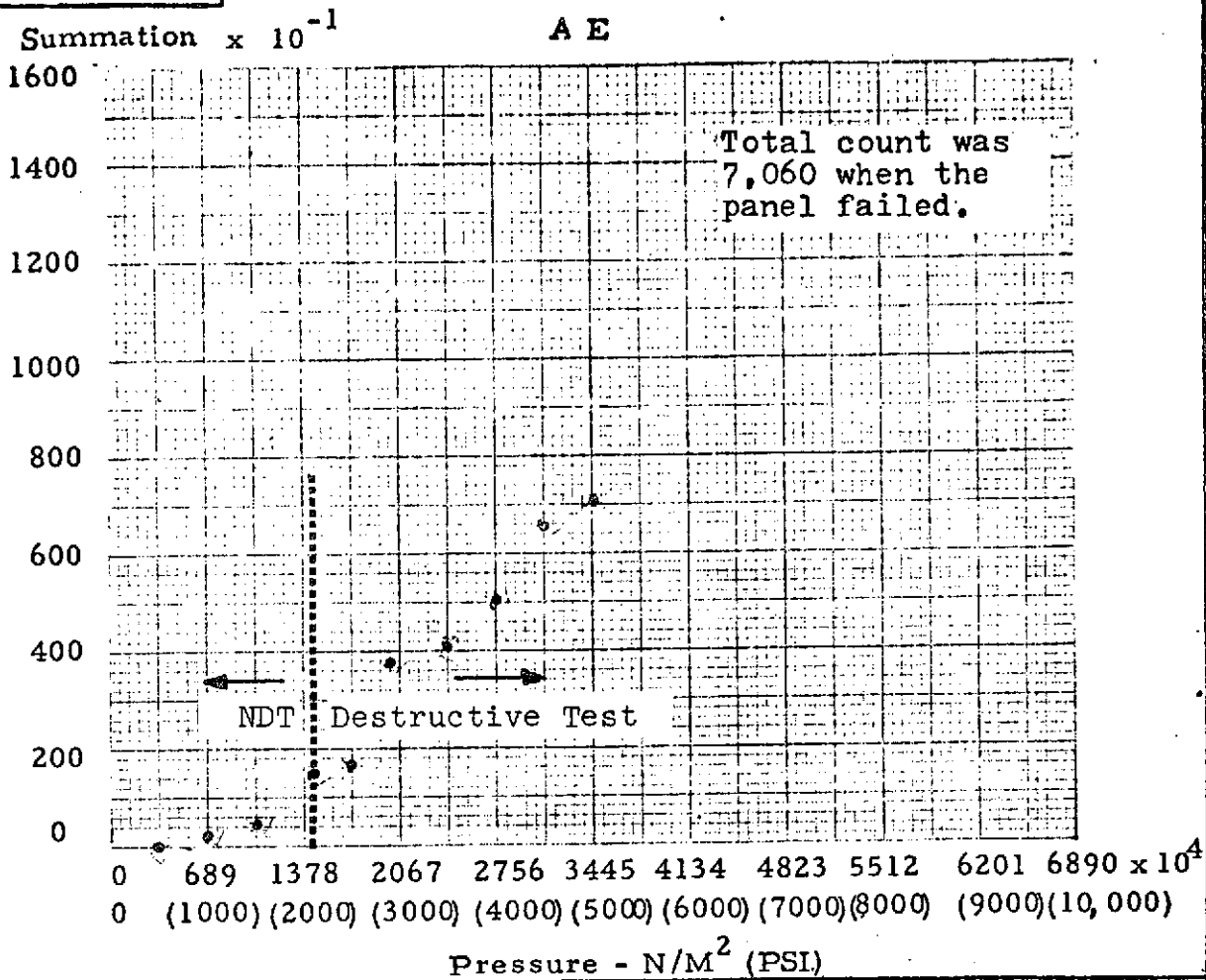


Section of planned weak bond showing separation after pressurization to destruction. Magnification 50X.

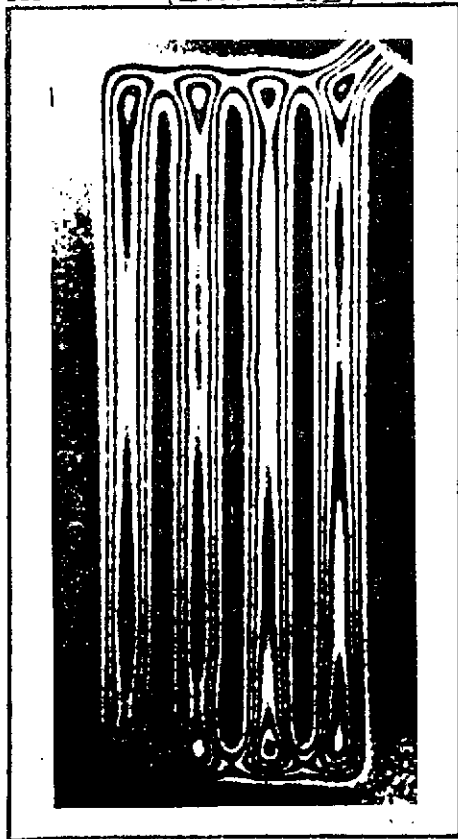
Section showing full bond from region just below the weak bond after destructive test. Magnification 50X.

FIGURE C-34

Panel No. C-38N

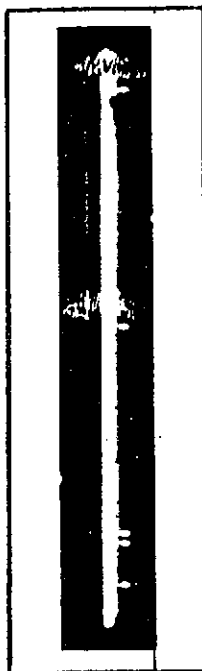


HNDT (Before AE)



Press. $13.8 \times 10^5 N/M^2$
(200 PSI)

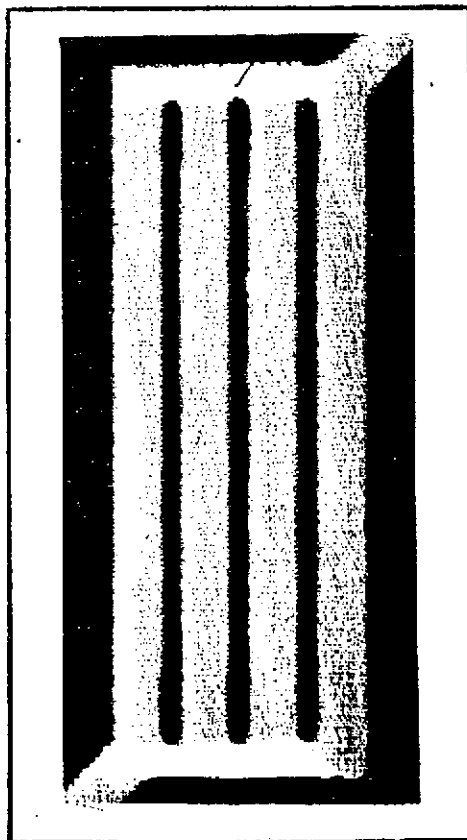
AE
FLAW LOCATOR
CENTER LAND



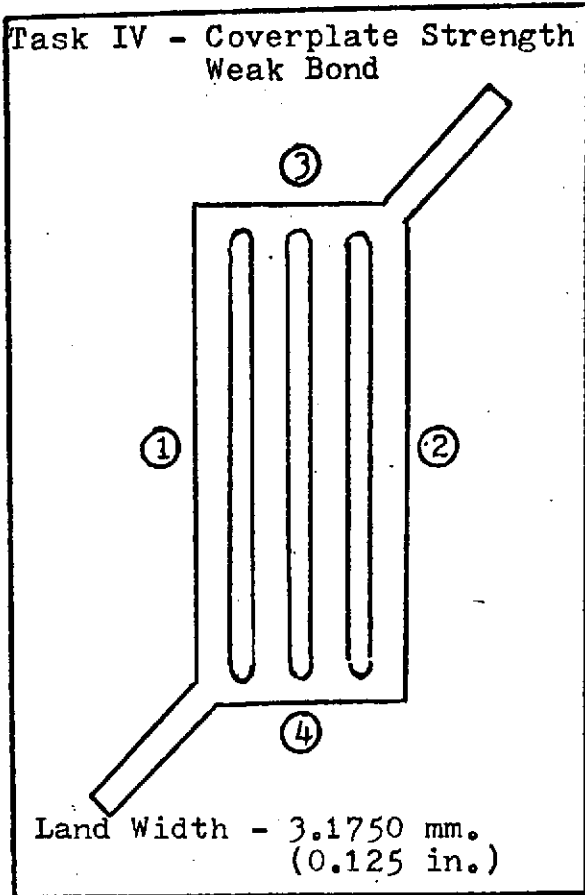
After NDE and
Destructive Test

137

UT



ELECTROFORMED PANEL NO. C-39N



BASEPLATE

MATERIAL: OFHC Copper
 CENTER LAND FLATNESS VARIATION:
 0.006 in. (0.1524 mm.)

THICKNESS:	MM.	INCHES
①	6.5888	0.2594
②	6.5557	0.2581
③	6.6599	0.2622
④	6.5126	0.2564

COVERPLATE

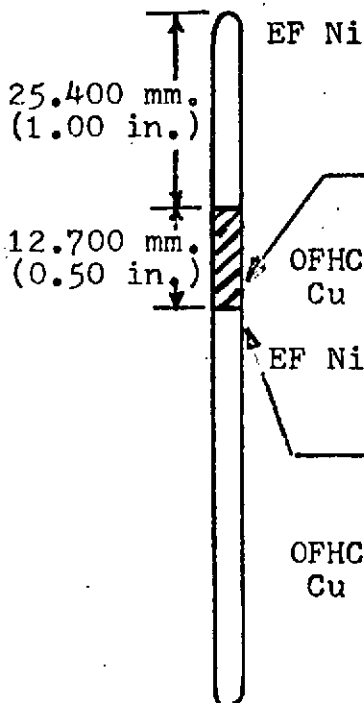
MATERIAL: Electroformed Nickel

THICKNESS:	MM.	INCHES
①	0.9246	0.0364
②	0.9195	0.0362
③	0.8484	0.0334
④	0.9754	0.0384

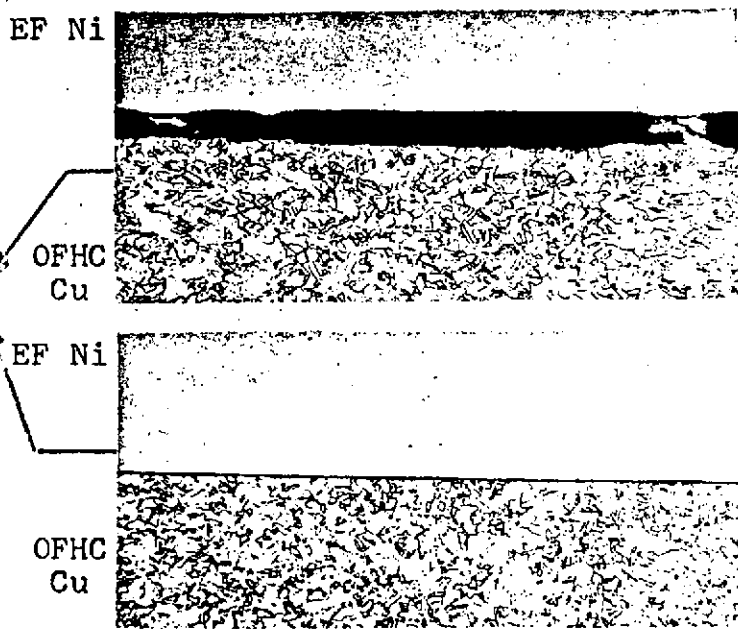
PRESSURE REQUIRED TO FAIL BOND:

Bond failed at a pressure of
 $5.52 \times 10^7 \text{ N/m}^2$ (8,000 psi).

CENTER LAND DEFECT



METALLOGRAPHIC ANALYSIS:

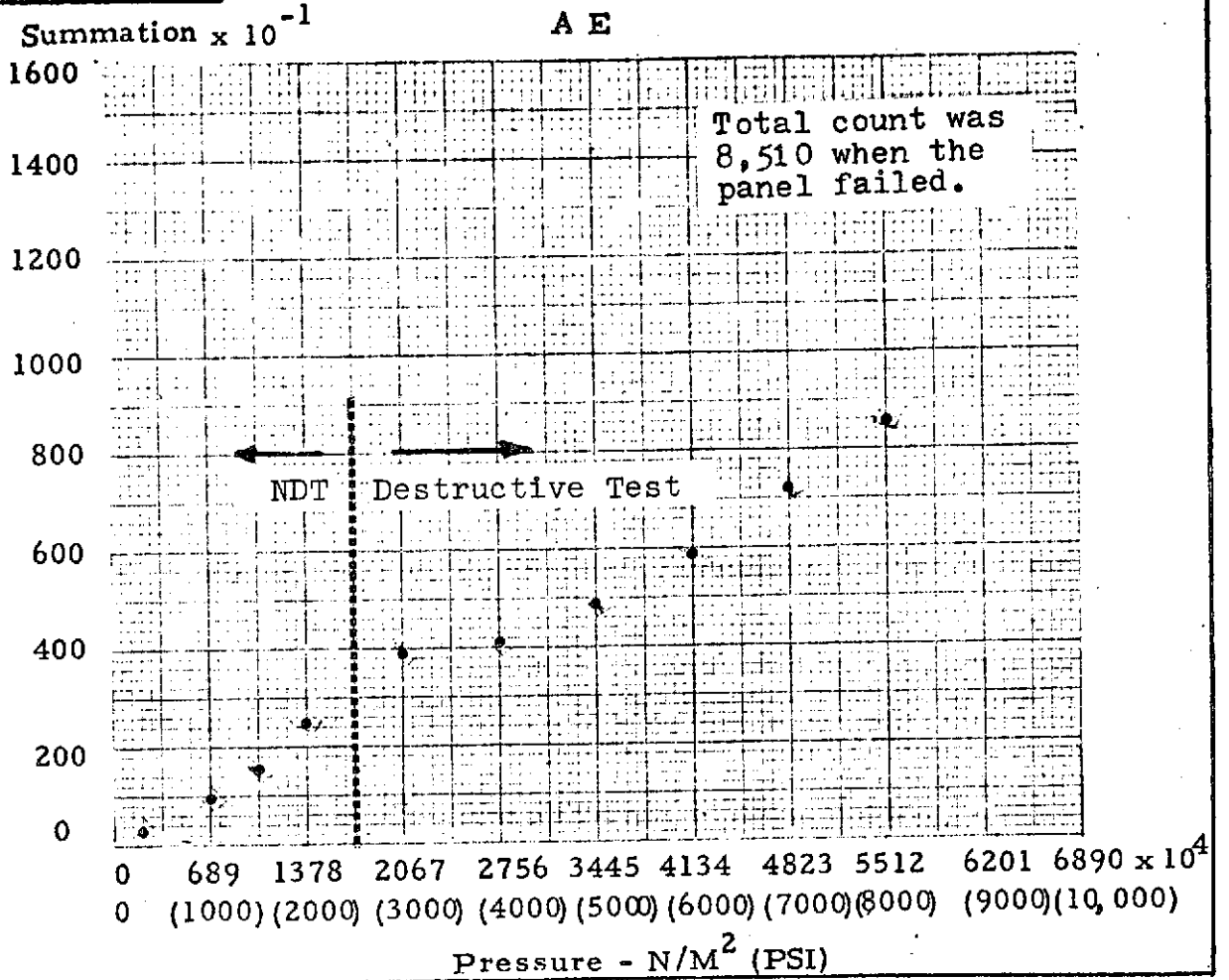


Planned weak bond section. Disturbance of OFHC copper indicates a stronger bond than planned. Magnification 50X

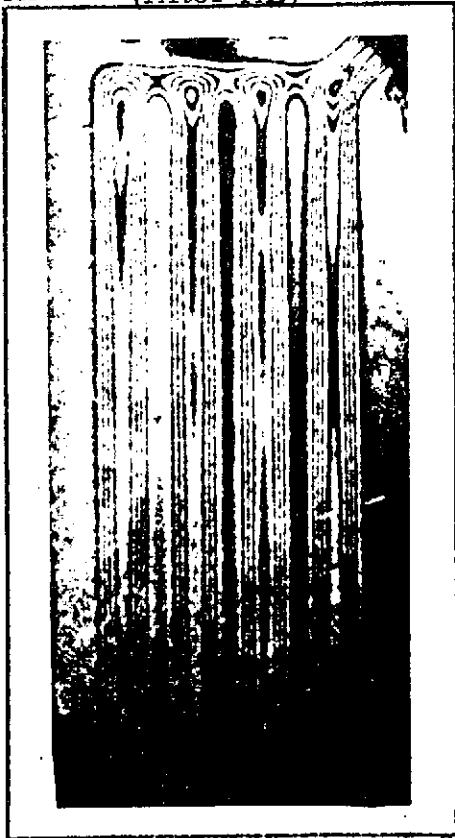
Section of full bond adjacent to planned weak bond. Magnification 50X.

FIGURE C-35

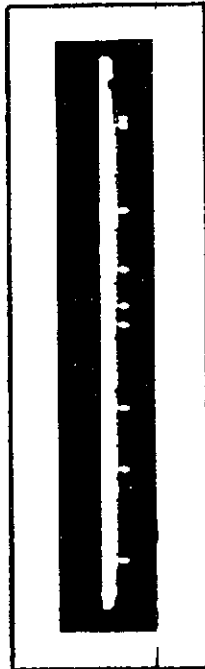
Panel No. C-39N



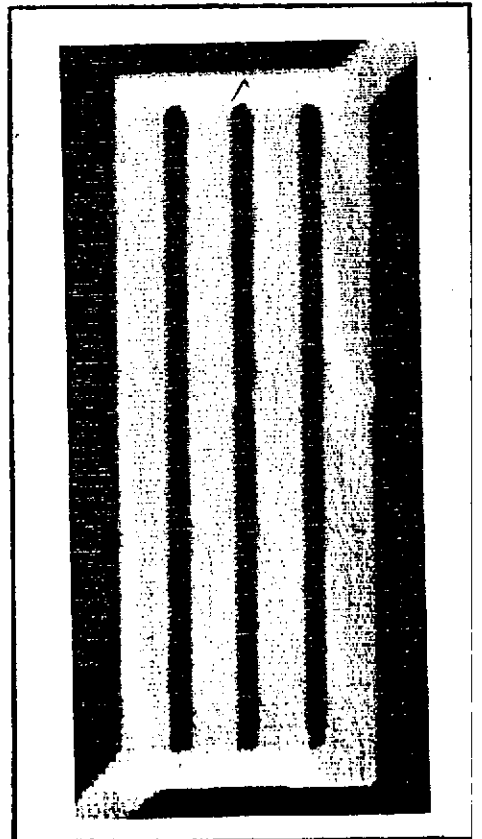
HNDT (After AE)



AE
FLAW LOCATOR
CENTER LAND

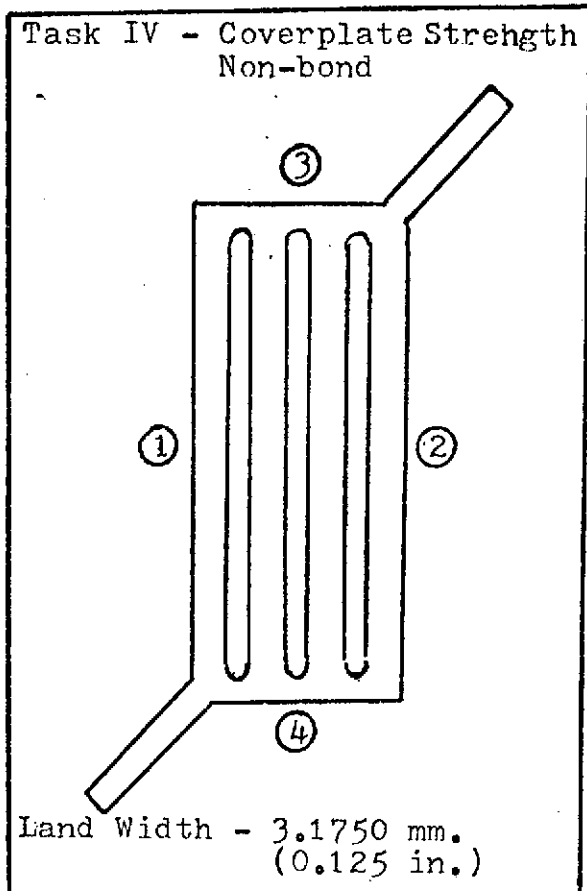


UT



Press. - 20.7×10^5 N/M^2
(300 PSI)

ELECTROFORMED PANEL NO. C-03N



BASEPLATE

MATERIAL: OFHC Copper

CENTER LAND FLATNESS VARIATION:

0.003 in. (0.0762 mm.)

THICKNESS:	MM.	INCHES
①	6.5964	0.2597
②	6.6472	0.2617
③	6.6269	0.2609
④	6.5811	0.2591

COVERPLATE

MATERIAL: Electroformed Nickel

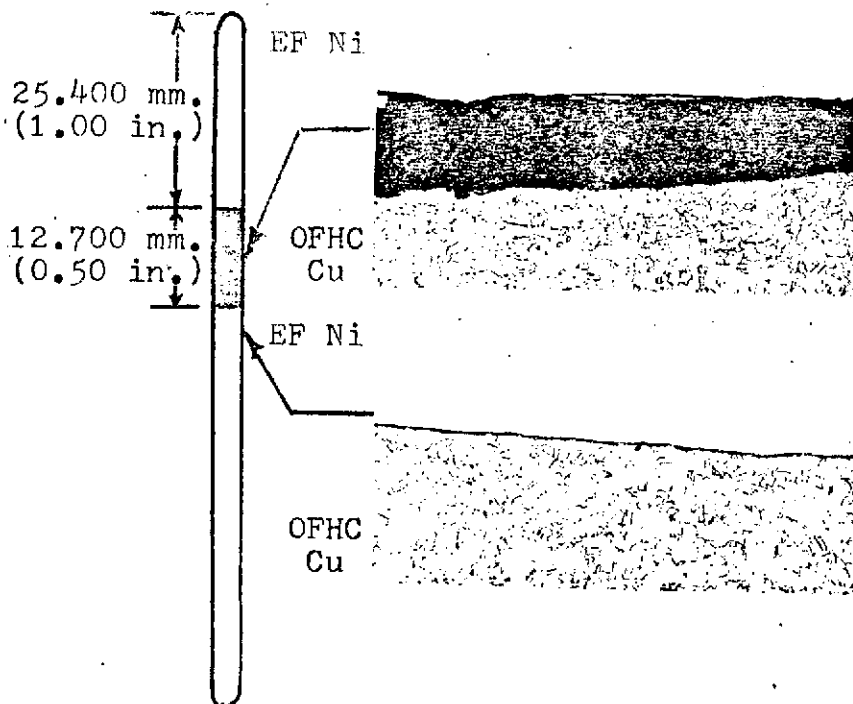
THICKNESS:	MM.	INCHES
①	0.9169	0.0361
②	0.9169	0.0361
③	0.9347	0.0368
④	0.9347	0.0368

PRESSURE REQUIRED TO FAIL BOND:

Panel failed at a pressure of 2.35×10^7 N/m² (3,400 psi).

CENTER LAND DEFECT

METALLOGRAPHIC ANALYSIS:

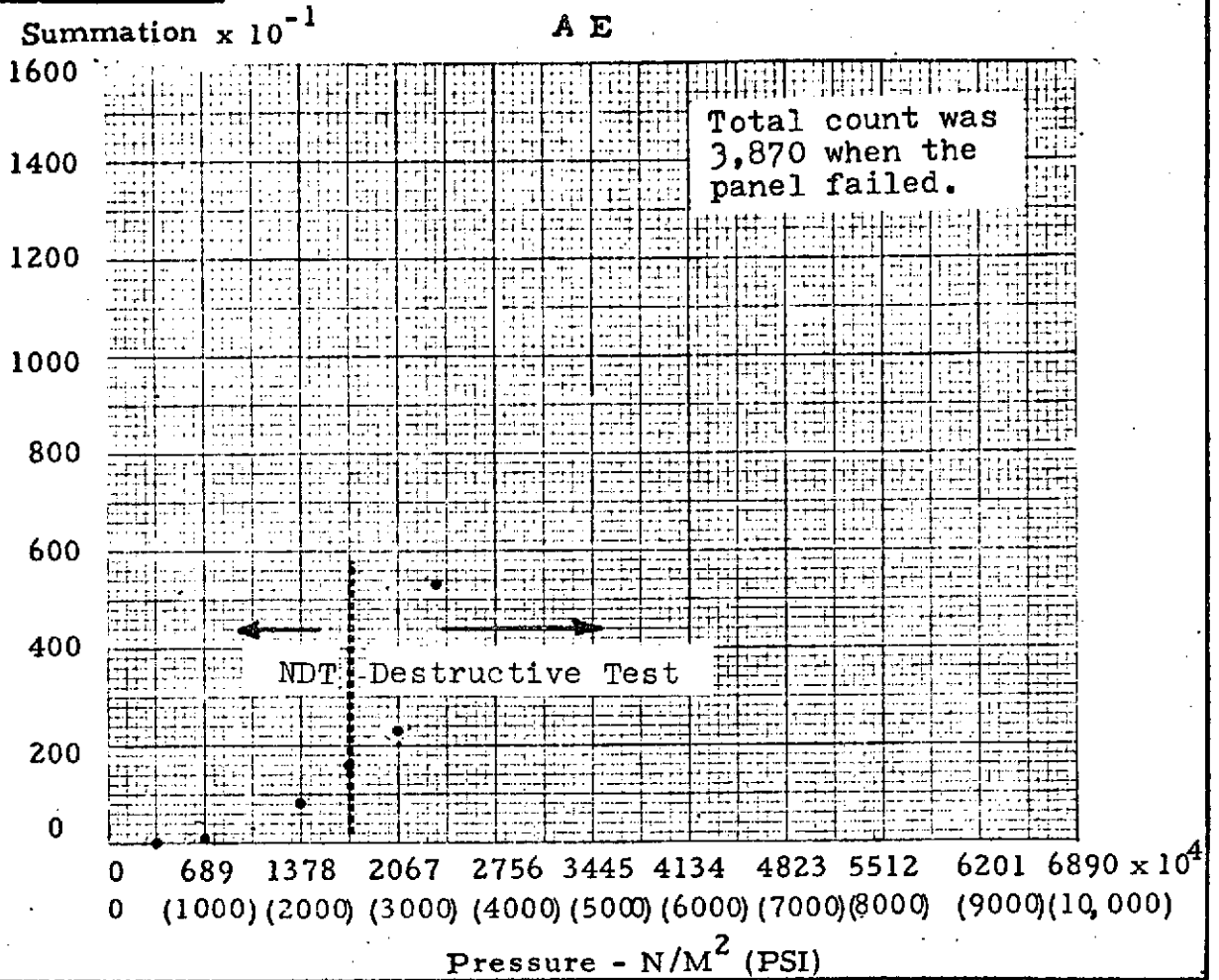


Section showing the planned nonbond separation after destructive test. Magnification 50X. Very slight metal disturbance indicates some "tack" bonding was present.

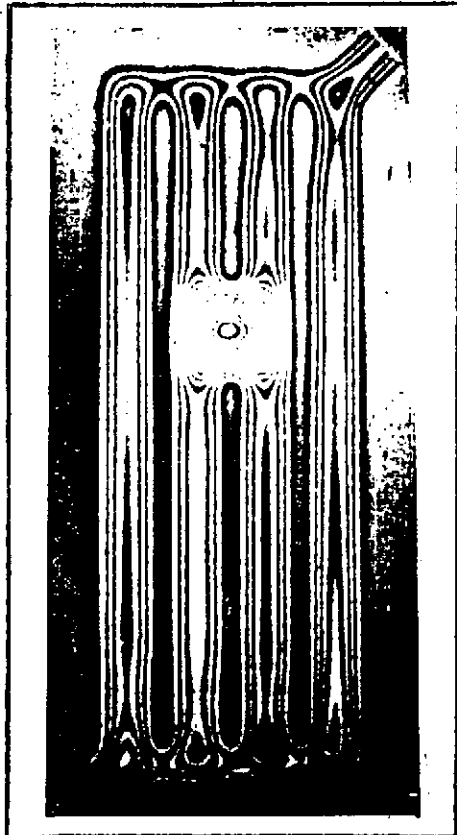
View of full bond area adjacent to the planned nonbond. Magnification 50X.

FIGURE C-36

Panel No. C-3N

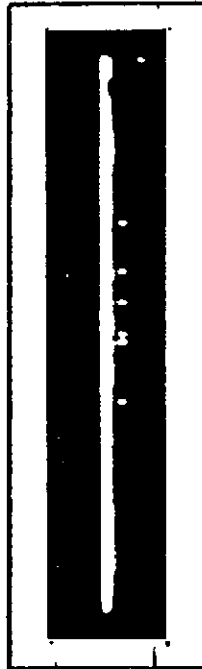


HNDT (Before AE)

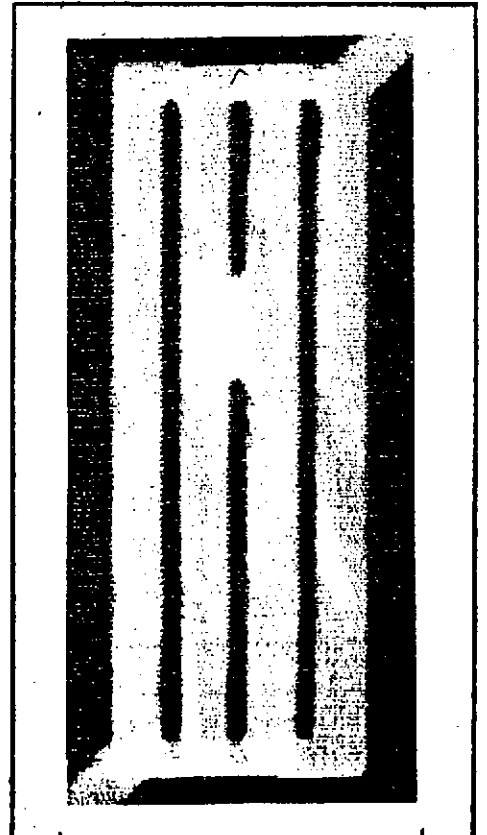


Press. 6.9×10^5 N/M²
(100 PSI)

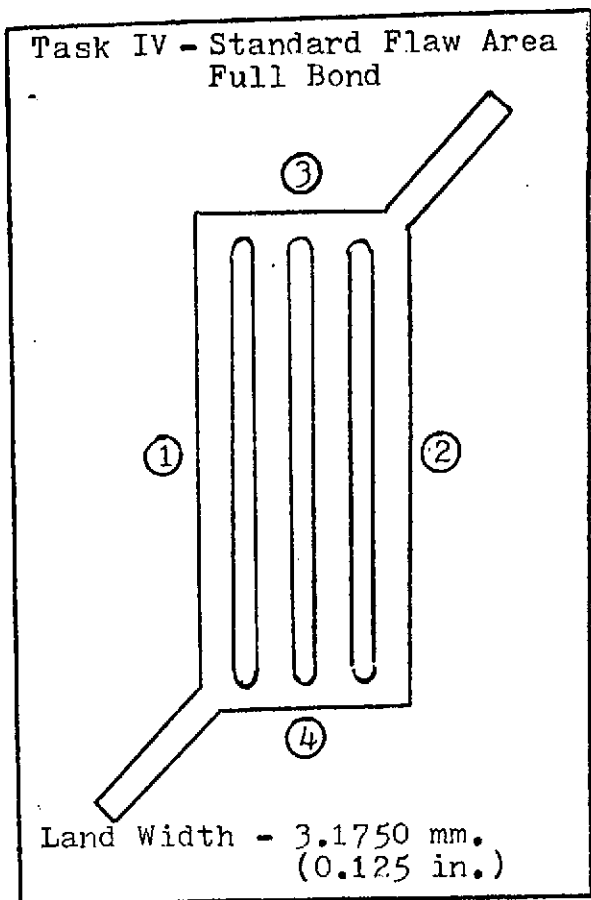
AE
FLAW LOCATOR
CENTER LAND



UT



ELECTROFORMED PANEL NO. C-01C



BASEPLATE

MATERIAL: OFHC Copper

CENTER LAND FLATNESS VARIATION:
0.002 in. (0.0508 mm.)

THICKNESS:	MM.	INCHES
①	6.4922	0.2556
②	6.4821	0.2552
③	6.5075	0.2562
④	6.4897	0.2555

COVERPLATE

MATERIAL: Electroformed Copper

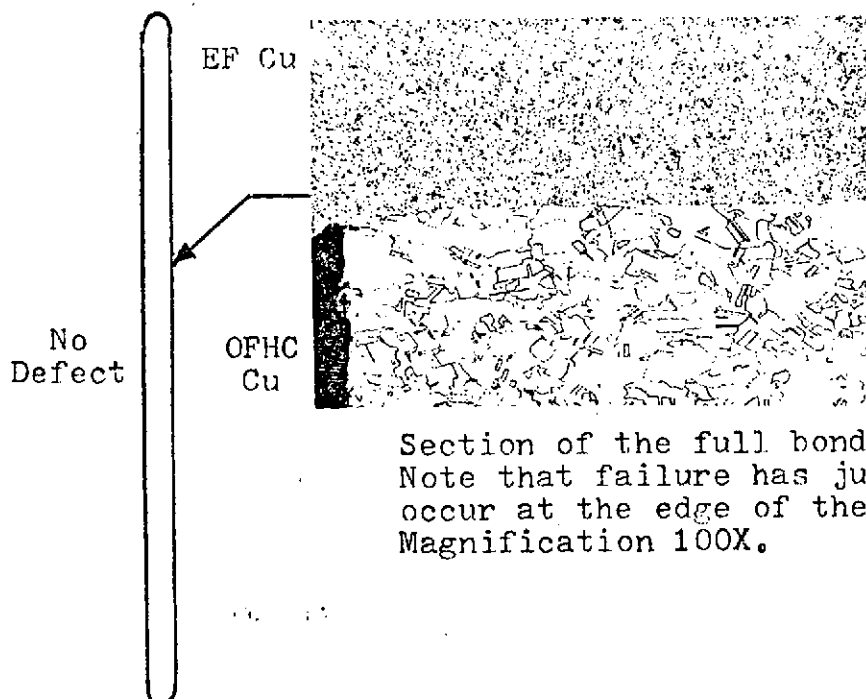
THICKNESS:	MM.	INCHES
①	1.2344	0.0486
②	1.2700	0.0500
③	1.2370	0.0487
④	1.2725	0.0501

PRESSURE REQUIRED TO FAIL BOND:

Panel failed at a pressure of
 5.52×10^7 N/m² (8,000 psi).
Failure was by manifold buckling.

CENTER LAND DEFECT.

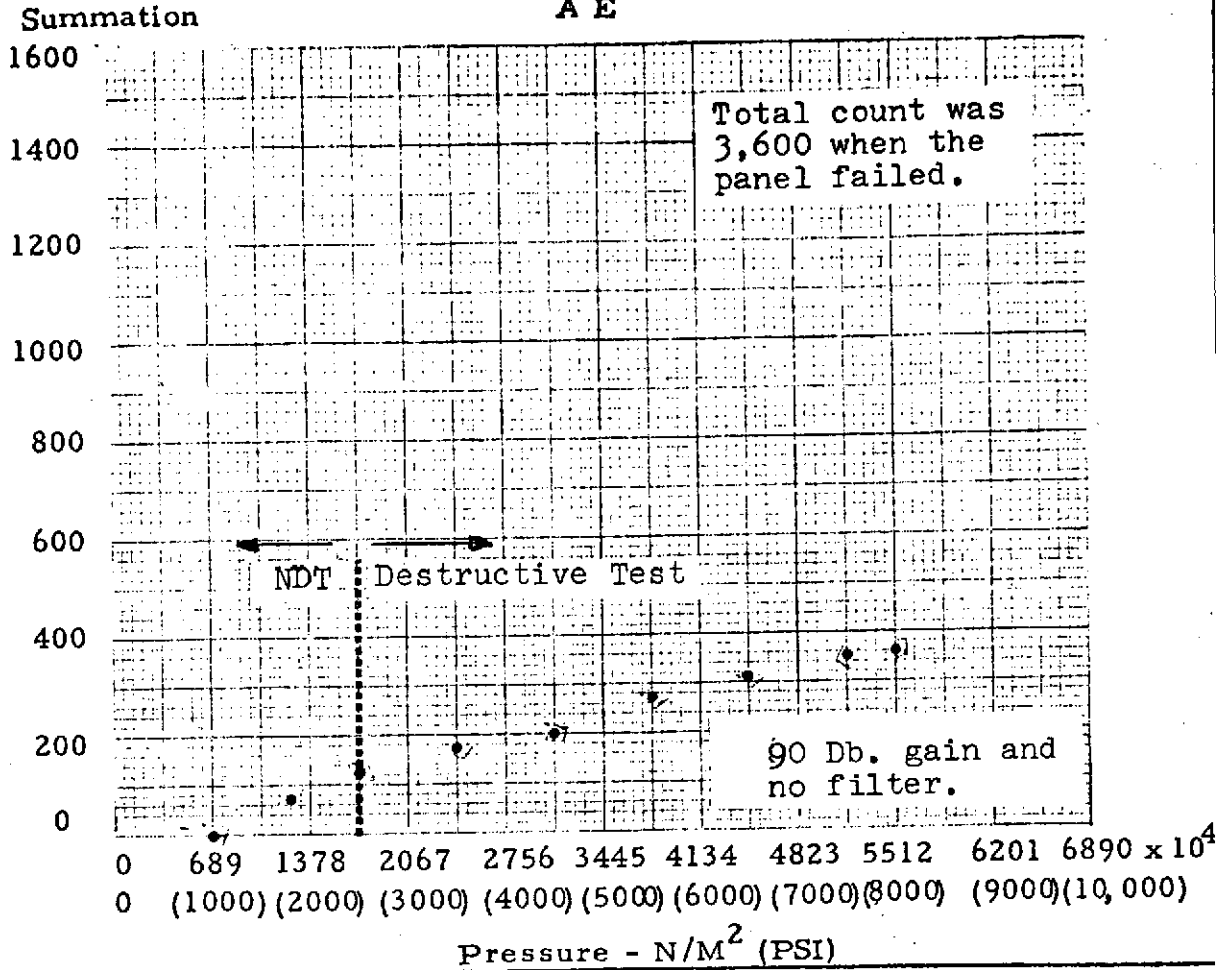
METALLOGRAPHIC ANALYSIS:



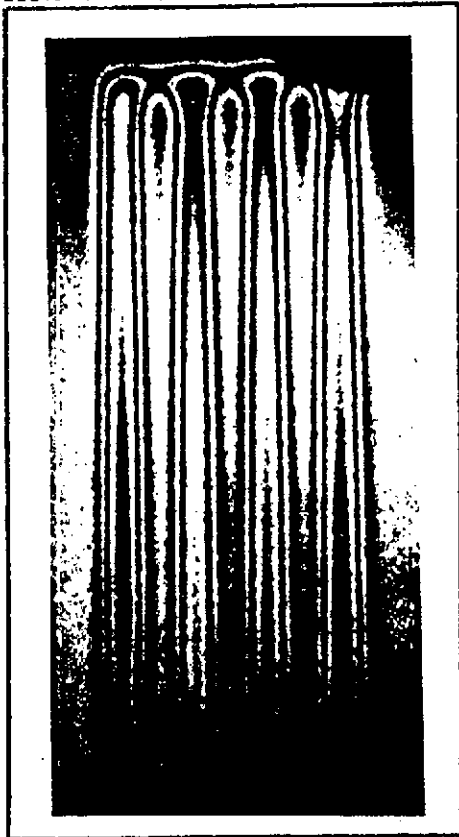
Section of the full bond in Land 2.
Note that failure has just begun to
occur at the edge of the land.
Magnification 100X.

FIGURE C-37

A E

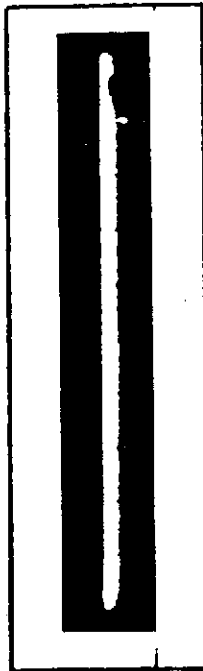


HNDT (After AE)



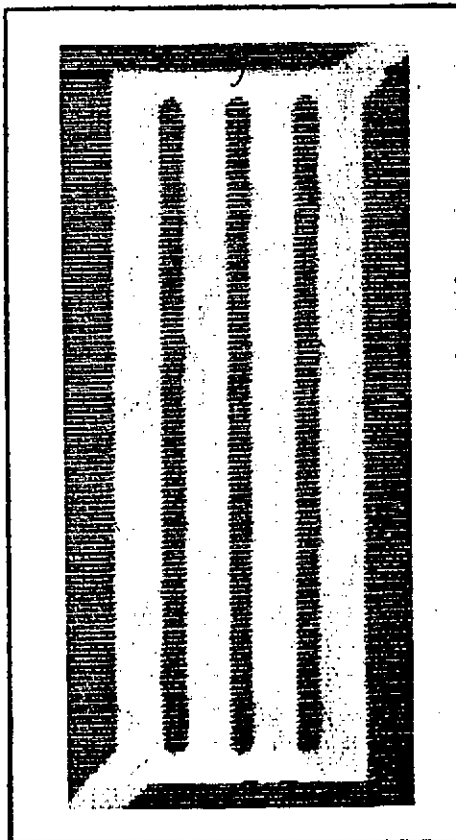
Press. 20.7×10^5 N/M²
(300 PSI)

AE
FLAW LOCATOR
CENTER LAND

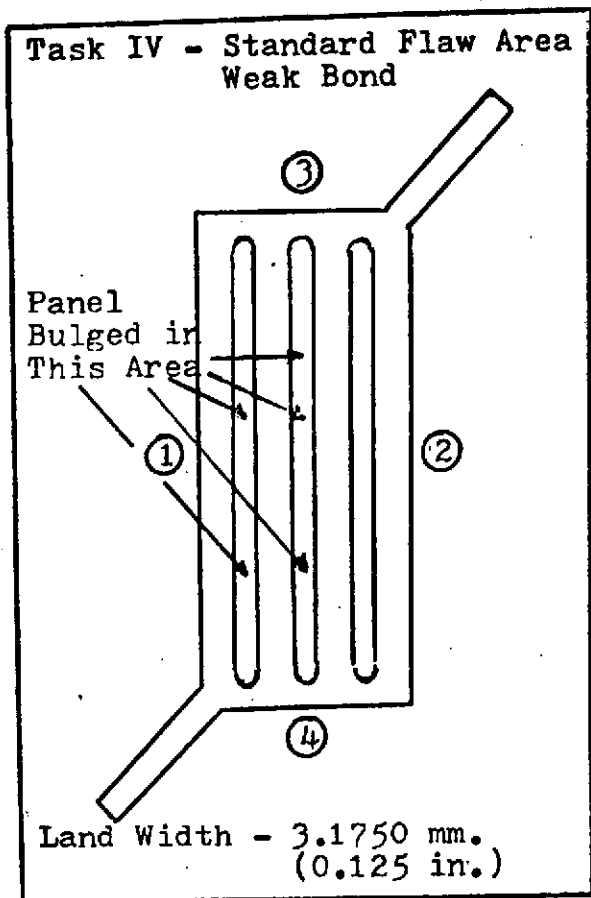


143

UT



ELECTROFORMED PANEL NO. C-16C



BASEPLATE

MATERIAL: OFHC Copper

CENTER LAND FLATNESS VARIATION:
0.002 in. (0.0508 mm.)

THICKNESS:	MM.	INCHES
①	6.6345	0.2612
②	6.6751	0.2628
③	6.6929	0.2635
④	6.6294	0.2610

COVERPLATE

MATERIAL: Electroformed Copper

THICKNESS:	MM.	INCHES
①	1.2598	0.0496
②	1.2700	0.0500
③	1.2675	0.0499
④	1.2624	0.0497

PRESSURE REQUIRED TO FAIL BOND:

Bond failed at a pressure of
 3.52×10^7 N/m² (5,100 psi).

CENTER LAND DEFECT

METALLOGRAPHIC ANALYSIS:

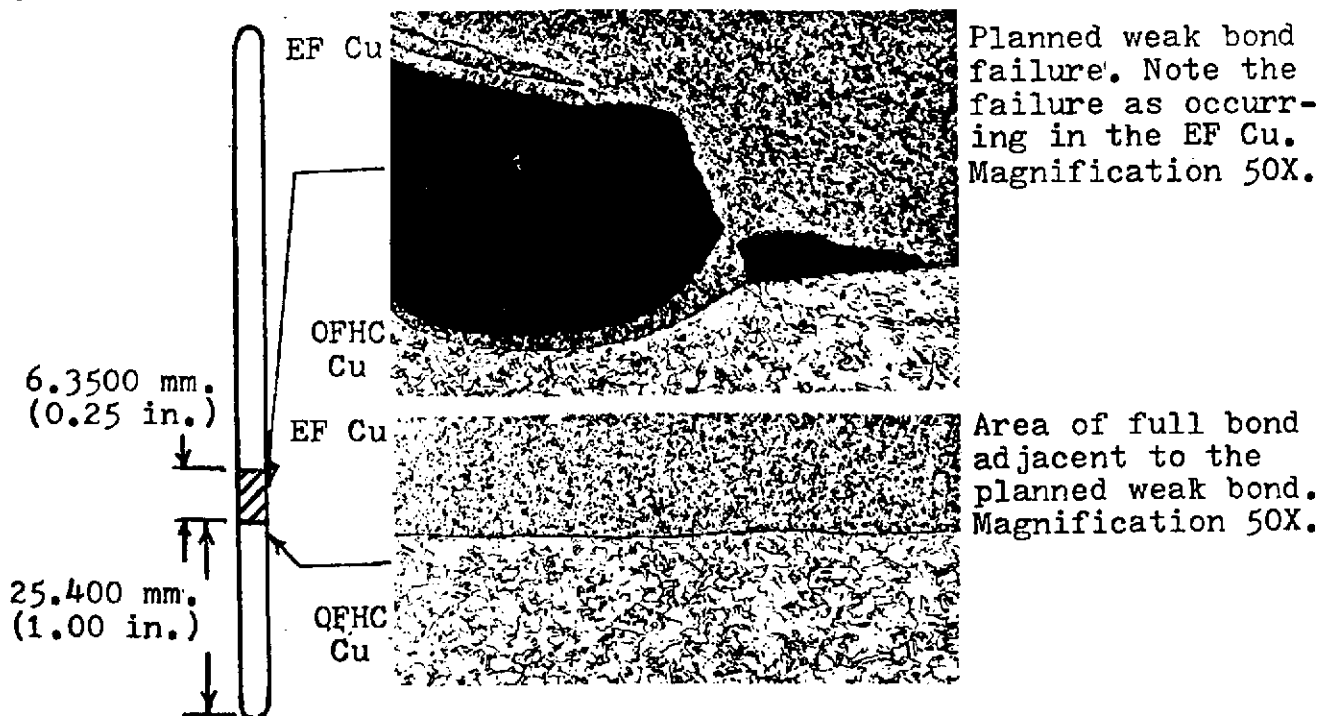
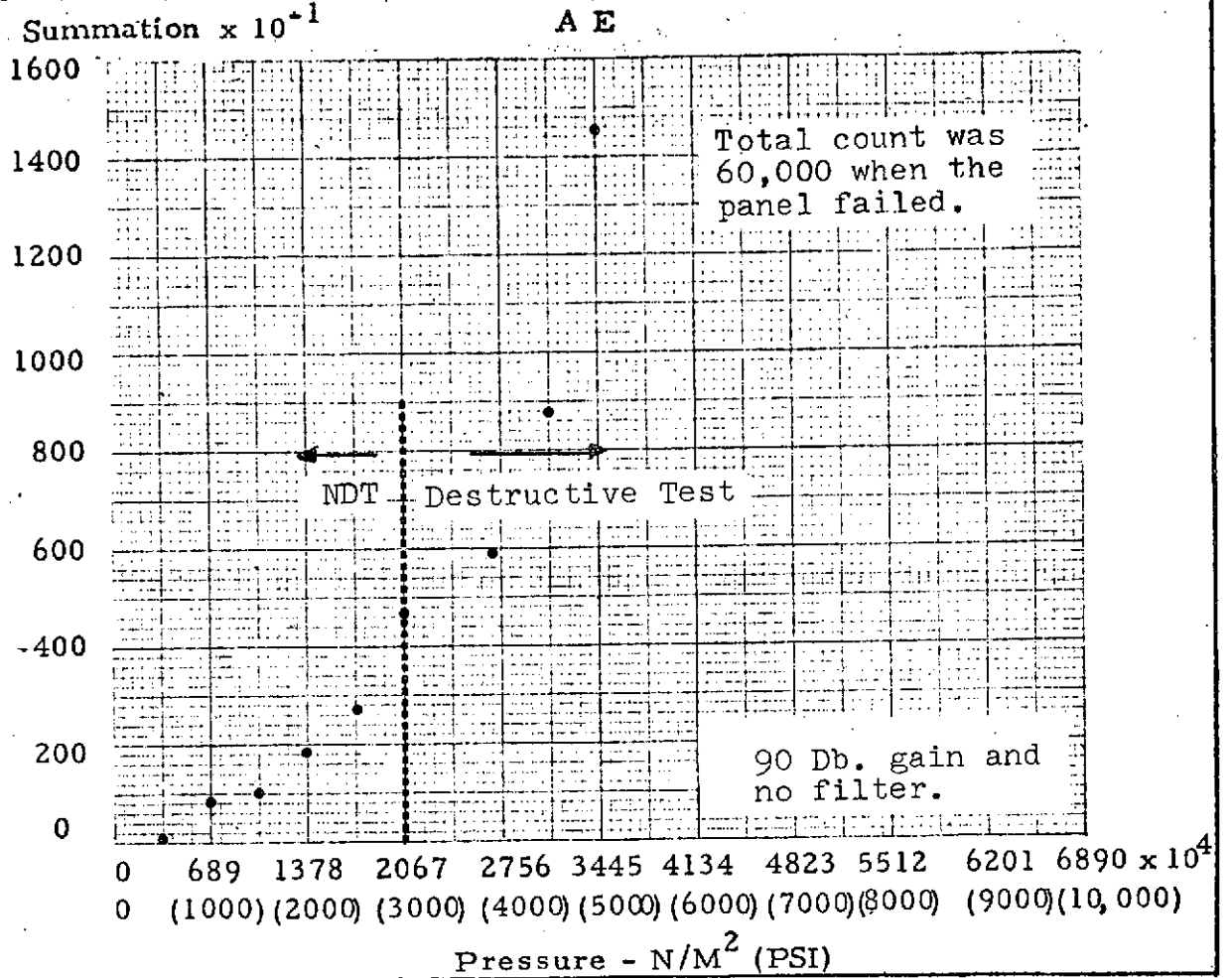


FIGURE C-38

Panel No. C-16C



HNDT (Before AE)



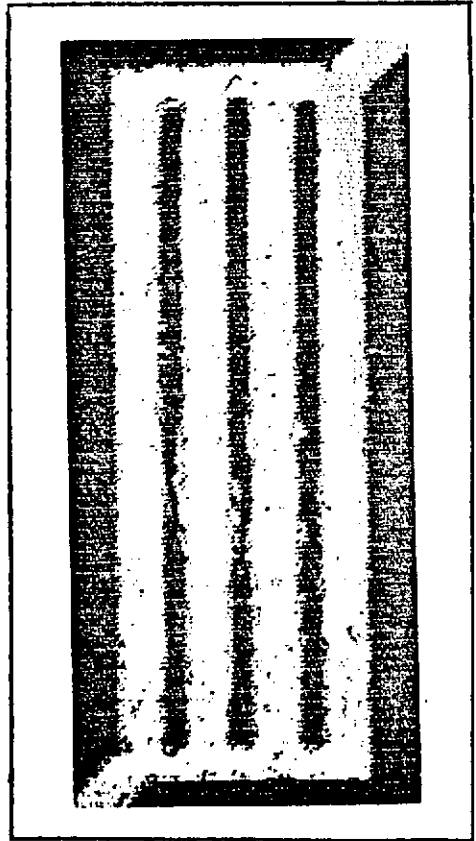
Press. $13.8 \times 10^5 N/M^2$
(200 PSI)

AE
FLAW LOCATOR
CENTER LAND

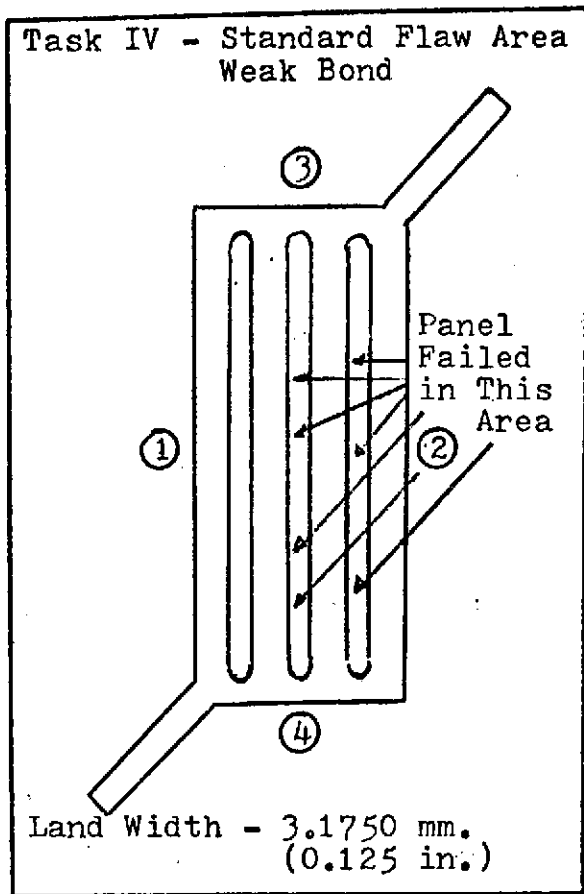


145

UT



ELECTROFORMED PANEL NO. C-17C



BASEPLATE

MATERIAL: OFHC Copper

CENTER LAND FLATNESS VARIATION:
0.005 in. (0.1270 mm.)

THICKNESS:	MM.	INCHES
①	6.4262	0.2530
②	6.4110	0.2524
③	6.3652	0.2506
④	6.4567	0.2542

COVERPLATE

MATERIAL: Electroformed Copper

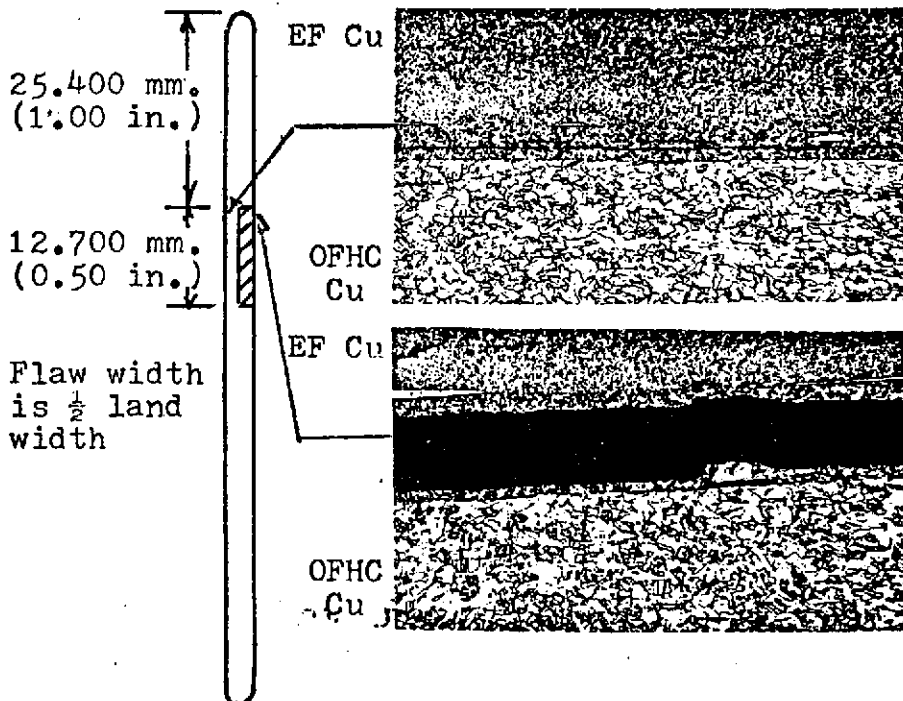
THICKNESS:	MM.	INCHES
①	1.2370	0.0487
②	1.2954	0.0510
③	1.2979	0.0511
④	1.1862	0.0467

PRESSURE REQUIRED TO FAIL BOND:

Bond failed at a pressure of
 $2.62 \times 10^7 \text{ N/m}^2$ (3,800 psi).

CENTER LAND DEFECT

METALLOGRAPHIC ANALYSIS:

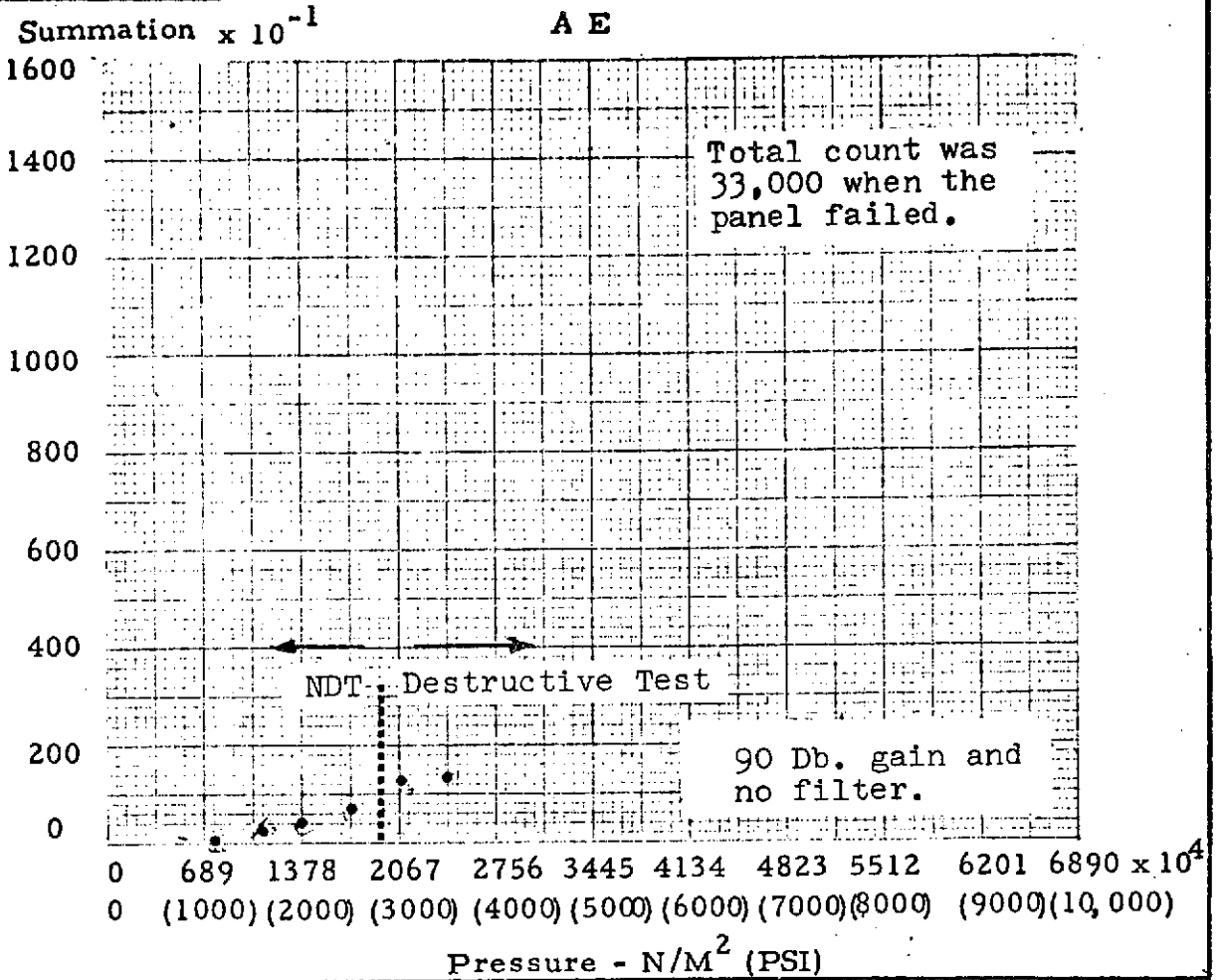


Section of planned full bond running parallel to the planned weak bond. Magnification 50X.

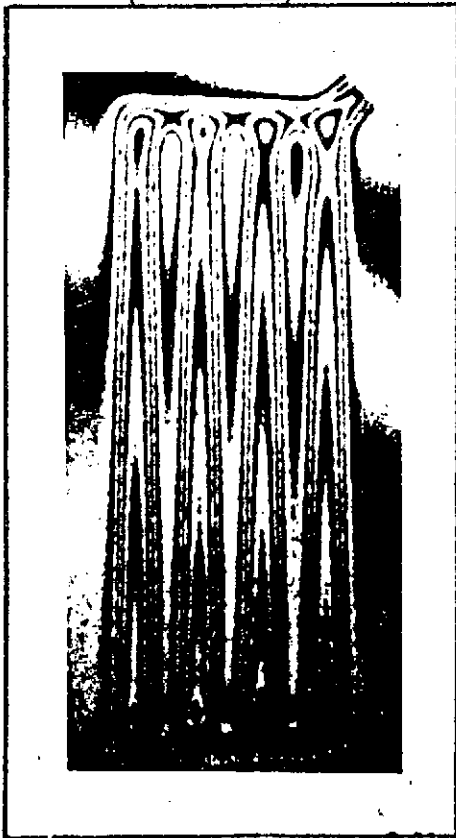
Section showing failure occurring in the planned weak bond area. Magnification 50X.

FIGURE C-39

Panel No. C-17C



HNDT (After AE)

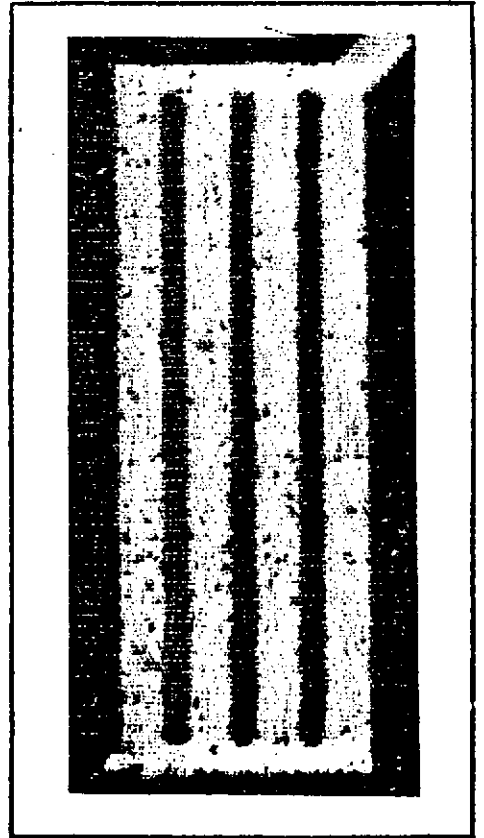


Press. 20.7×10^5 N/M^2
(300 PSI)

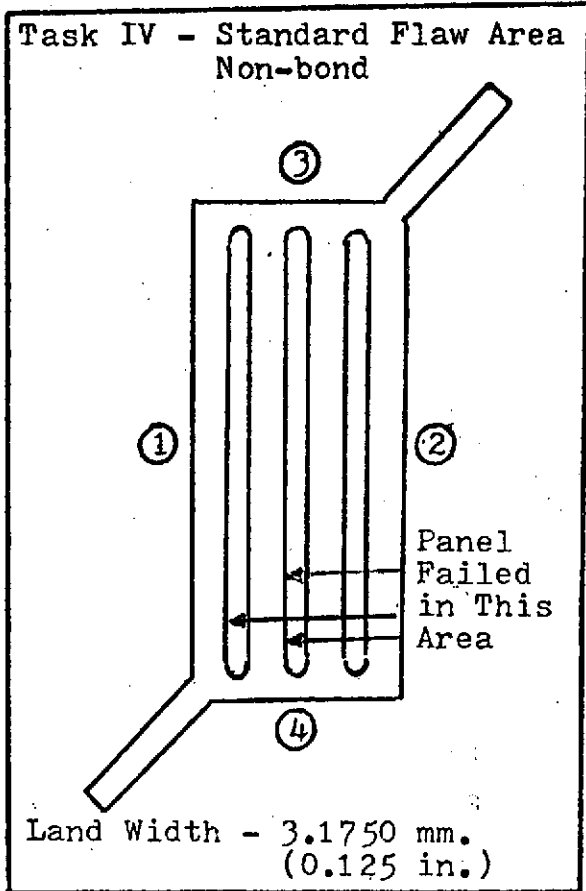
AE
FLAW LOCATOR
CENTER LAND



UT



ELECTROFORMED PANEL NO. C-18C "A"



BASEPLATE

MATERIAL: OFHC Copper

CENTER LAND FLATNESS VARIATION:
0.001 in. (0.0254 mm.)

THICKNESS:	MM.	INCHES
①	6.3830	0.2513
②	6.3500	0.2500
③	6.3754	0.2510
④	6.4135	0.2525

COVERPLATE

MATERIAL; Electroformed Copper

THICKNESS:	MM.	INCHES
①	1.3056	0.0514
②	1.2751	0.0502
③	1.3157	0.0518
④	1.2675	0.0499

PRESSURE REQUIRED TO FAIL BOND:

Panel failed at a pressure of
 $1.31 \times 10^7 \text{ N/m}^2$ (1,900 psi).

CENTER LAND DEFECT

METALLOGRAPHIC ANALYSIS:

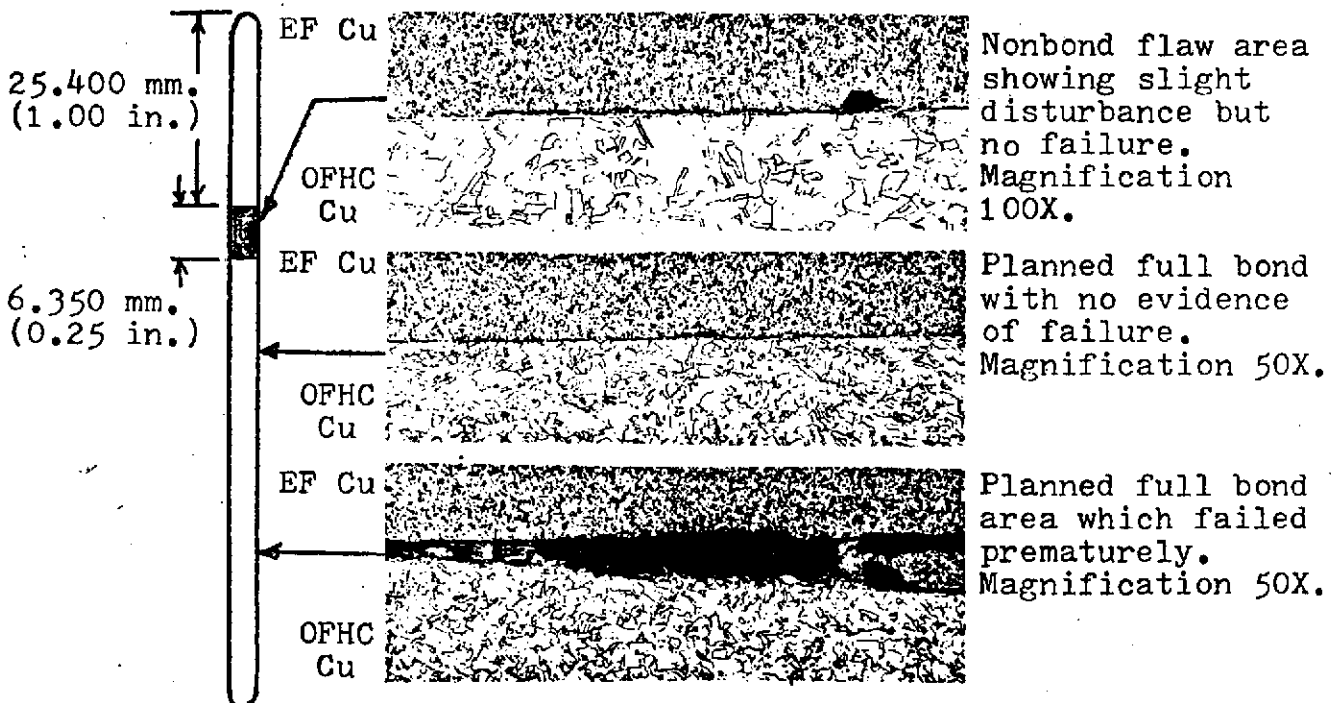
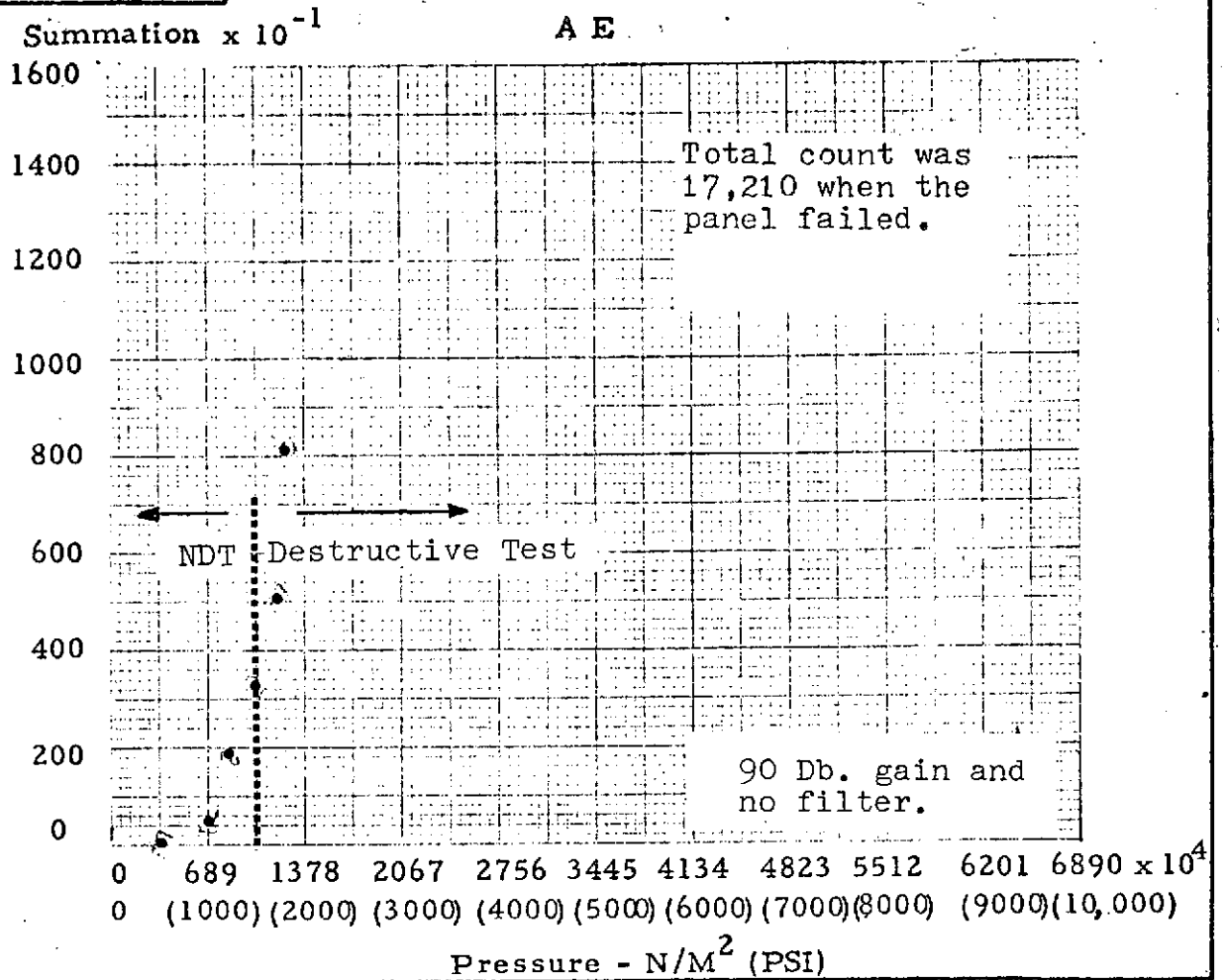


FIGURE C-40

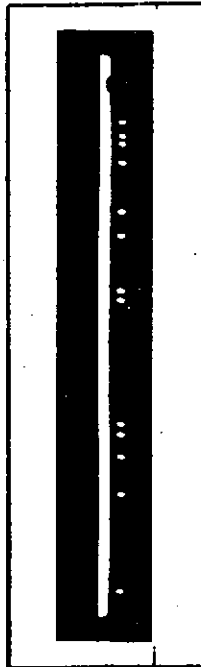
Panel No. C-18C "A"



HNDT

No hologram
was made
due to unexpected
bulge from
low pressure
A E test

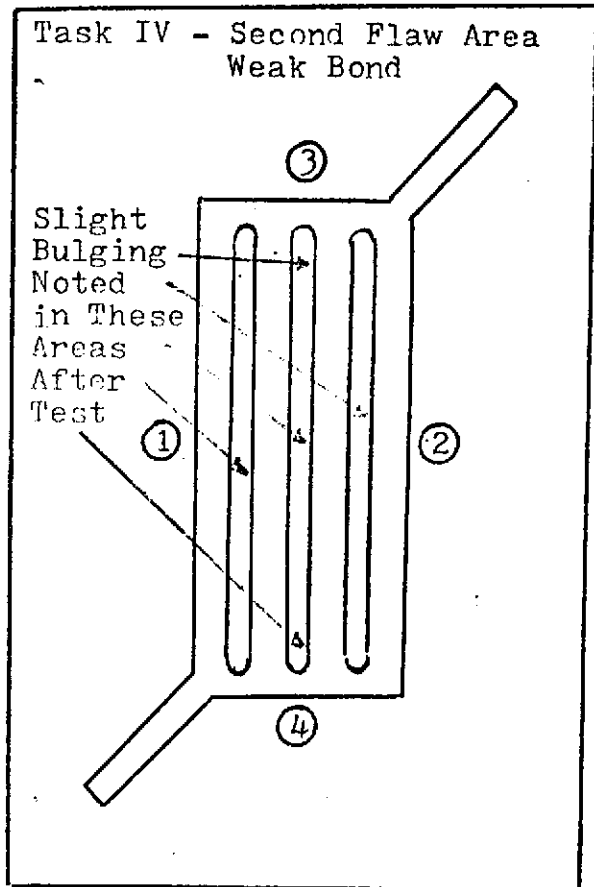
AE
FLAW LOCATOR
CENTER LAND



UT



ELECTROFORMED PANEL NO. C-19C



BASEPLATE

MATERIAL: OFHC Copper

CENTER LAND FLATNESS VARIATION:
0.004 in. (0.1016 mm.)

THICKNESS:	MM.	INCHES
①	6.5532	0.2580
②	6.5507	0.2579
③	6.5913	0.2595
④	6.5303	0.2571

COVERPLATE

MATERIAL: Electroformed Copper

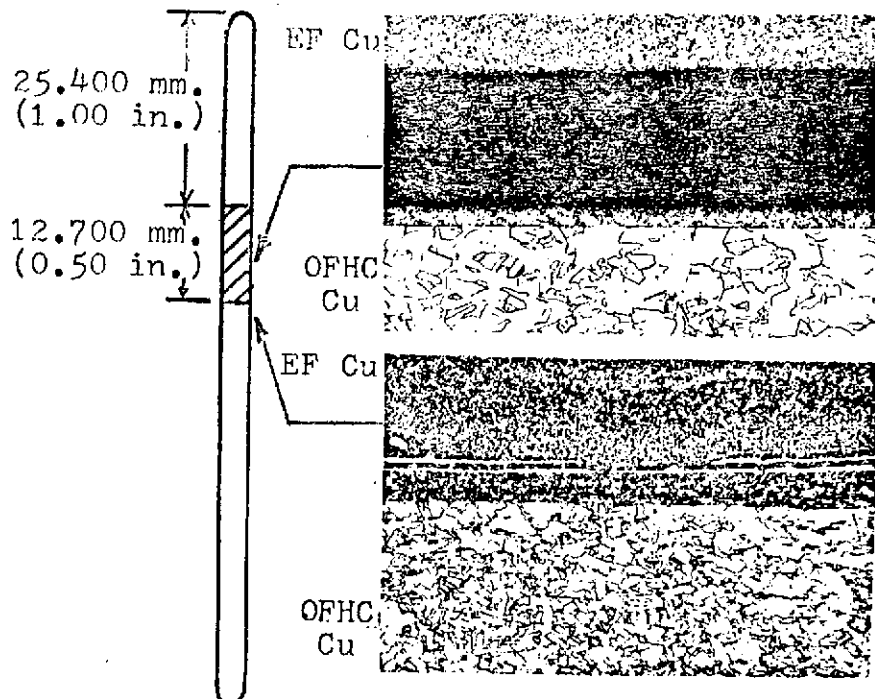
THICKNESS:	MM.	INCHES
①	1.2548	0.0494
②	1.2319	0.0485
③	1.2065	0.0475
④	1.2598	0.0496

PRESSURE REQUIRED TO FAIL BOND:

Panel failed at a pressure of
 1.24×10^7 N/m² (1,800 psi).

CENTER LAND DEFECT

METALLOGRAPHIC ANALYSIS:

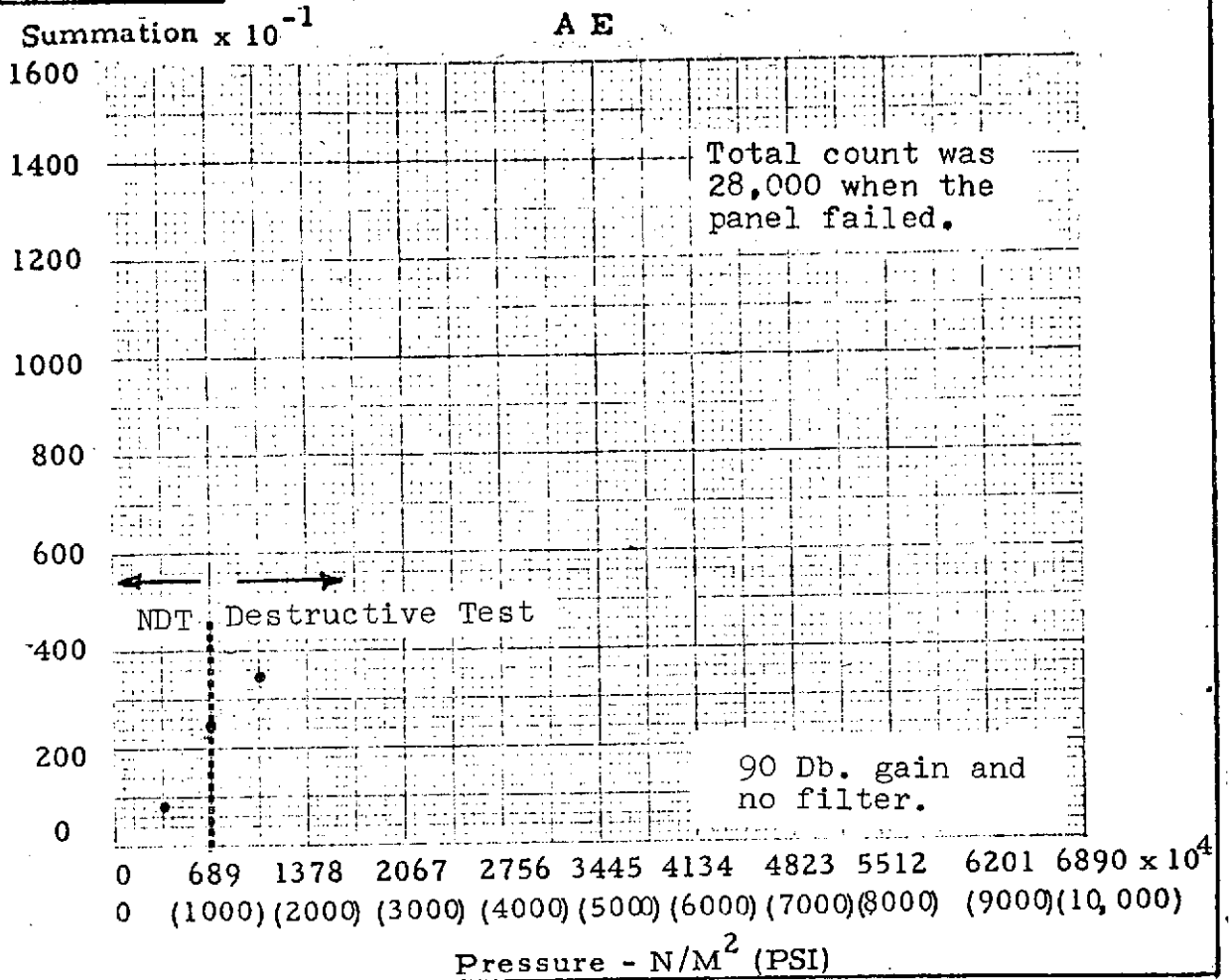


Section through the planned weak bond. Note separation as occurring between the initial copper deposit layer and subsequent build-up. Magnification 100X.

Section showing the full bond near the planned weak bond. Magnification 50X.

FIGURE C-41

Panel No. C-19C

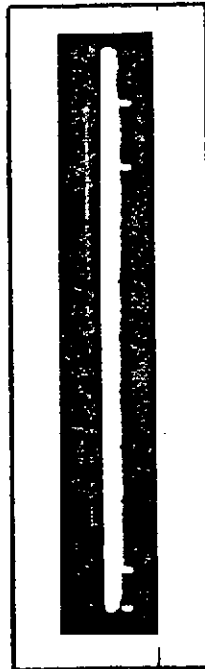


HNDT (After AE)



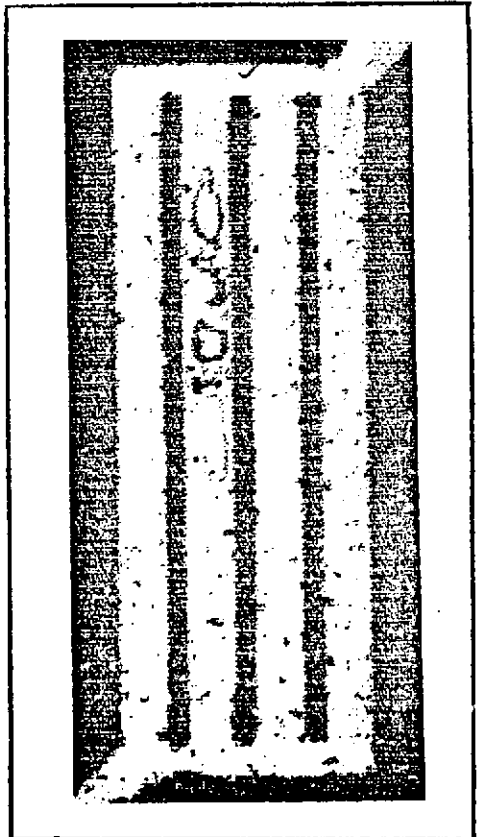
Press. $27.6 \times 10^5 N/M^2$
(400 PSI)

AE
FLAW LOCATOR
CENTER LAND

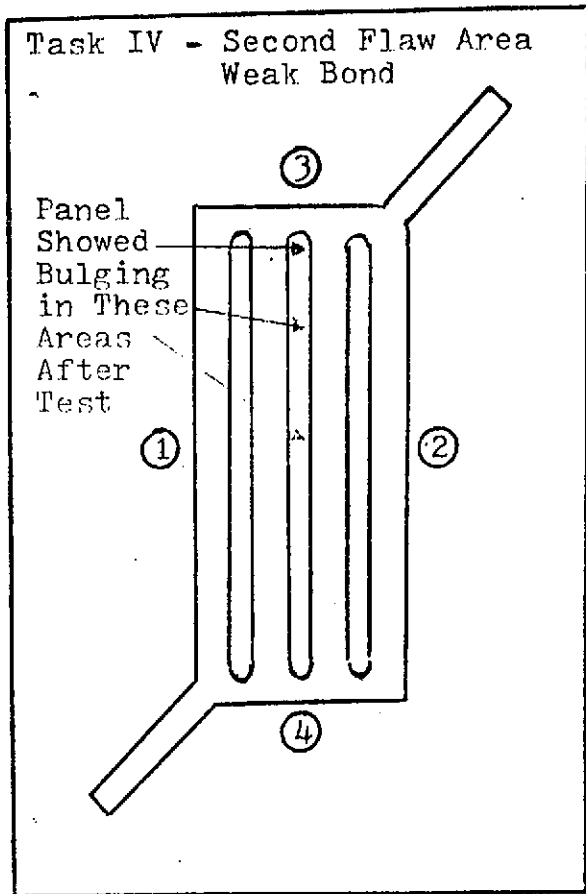


151

UT



ELECTROFORMED PANEL NO. C-20C



BASEPLATE

MATERIAL: OFHC Copper
CENTER LAND FLATNESS VARIATION:
0.002 in. (0.0508 mm.)

THICKNESS:	MM.	INCHES
①	6.6040	0.2600
②	6.6396	0.2614
③	6.6243	0.2608
④	6.6091	0.2602

COVERPLATE

MATERIAL: Electroformed Copper

THICKNESS:	MM.	INCHES
①	1.2471	0.0491
②	1.2954	0.0510
③	1.3081	0.0515
④	1.2979	0.0511

PRESSURE REQUIRED TO FAIL BOND:

Bond failed at a pressure of $1.31 \times 10^7 \text{ N/m}^2$ (1,900 psi).

CENTER LAND DEFECT

METALLOGRAPHIC ANALYSIS:

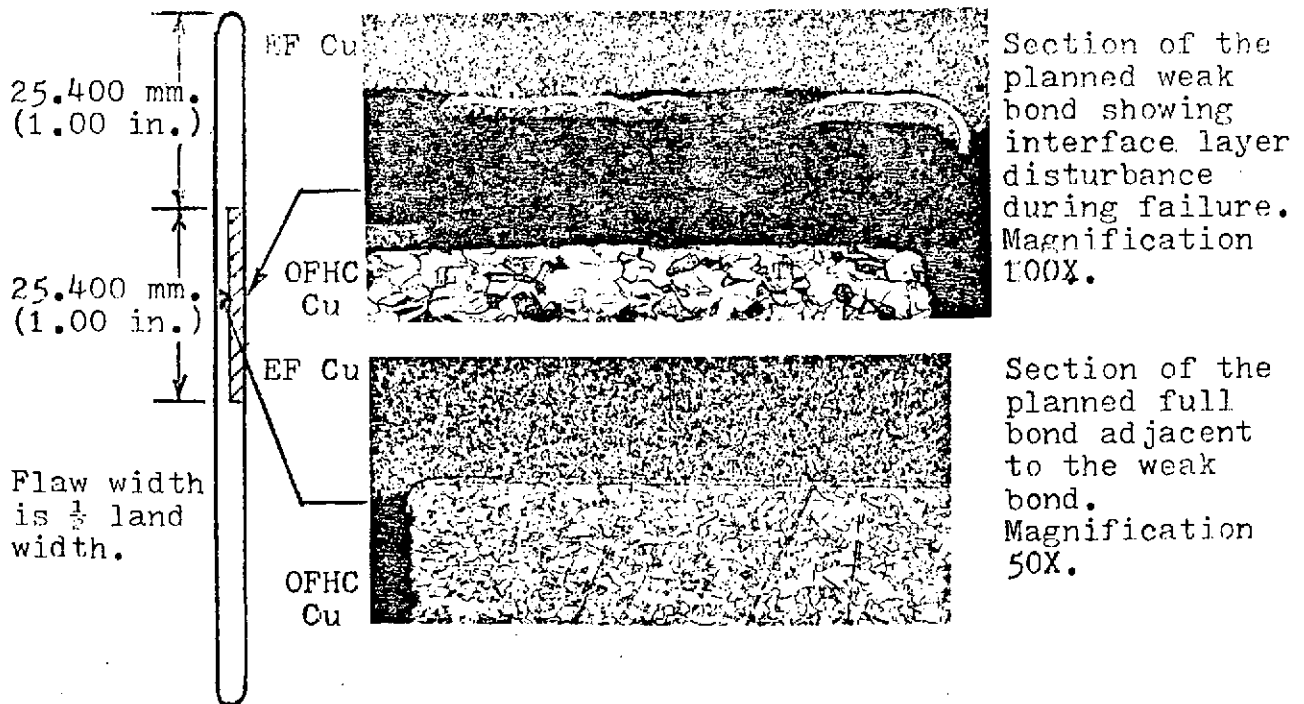
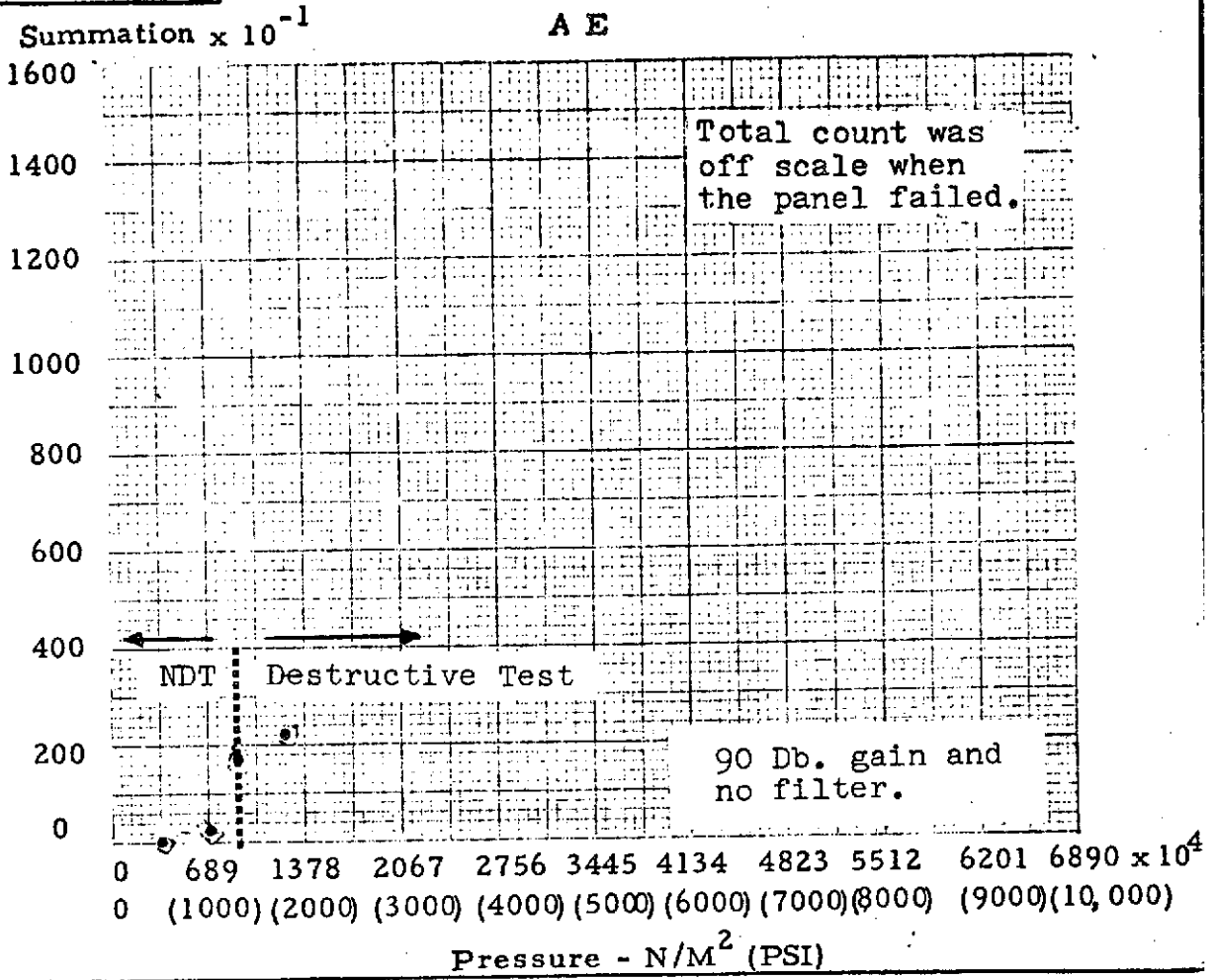
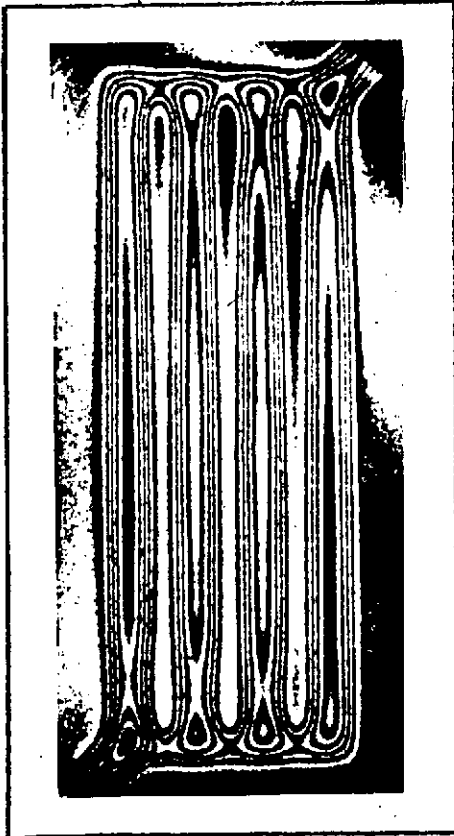


FIGURE C-42

Panel No. C-20C

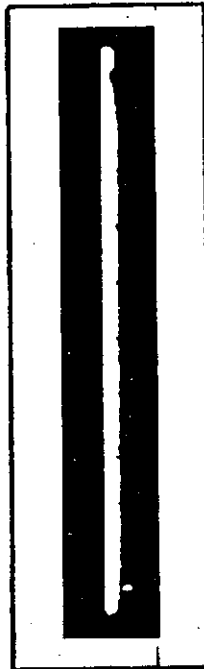


HNDT (After AE)

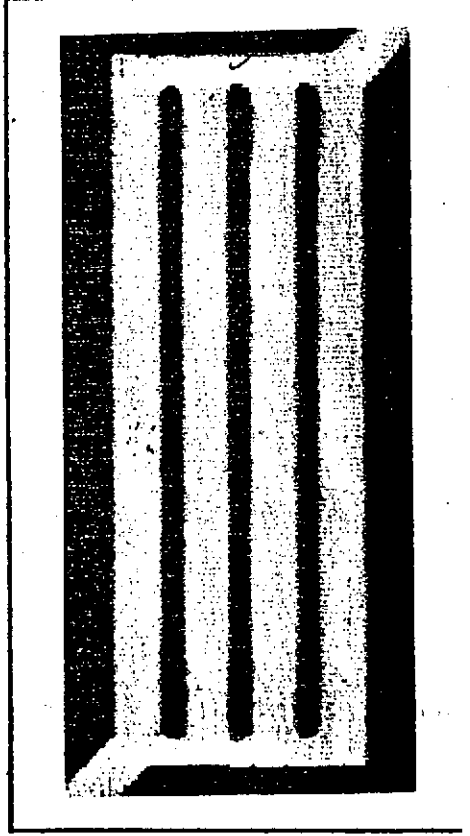


Press. 27.6×10^5 N/M^2
(400 PSI)

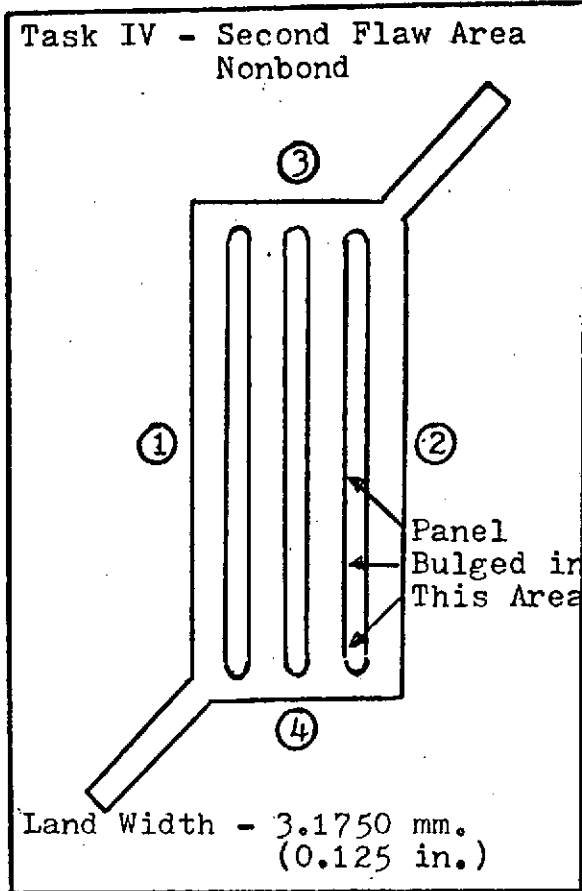
A E
FLAW LOCATOR
CENTER LAND



UT



ELECTROFORMED PANEL NO. C-21C "A"



BASEPLATE

MATERIAL: OFHC Copper

CENTER LAND FLATNESS VARIATION:
0.006 in. (0.1524 mm.)

THICKNESS:	MM.	INCHES
①	6.3119	0.2485
②	6.2916	0.2477
③	6.3043	0.2482
④	6.3195	0.2488

COVERPLATE

MATERIAL: Electroformed Copper

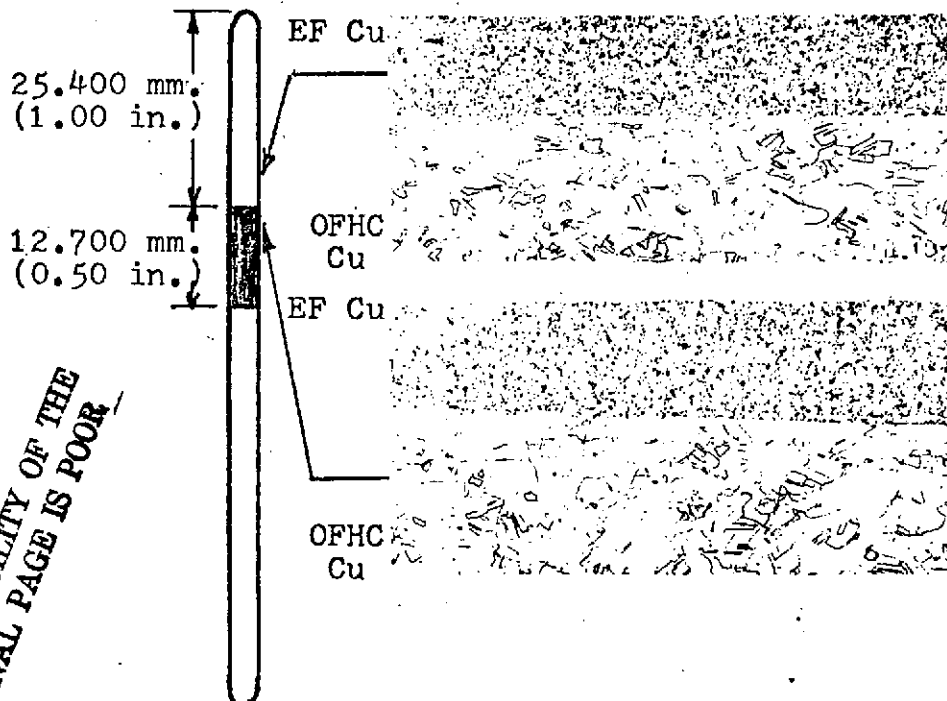
THICKNESS:	MM.	INCHES
①	1.2929	0.0509
②	1.2852	0.0506
③	1.3030	0.0513
④	1.2700	0.0500

PRESSURE REQUIRED TO FAIL BOND:

Panel failed at a pressure of
 $1.79 \times 10^7 \text{ N/m}^2$ (2,600 psi).

CENTER LAND DEFECT

METALLOGRAPHIC ANALYSIS:



Section from the planned full bond area showing no failure after the destructive test. Magnification 100X.

Section from the planned nonbond. The bondline has the appearance of a full or weak bond and shows no evidence of failure. Magnification 100X.

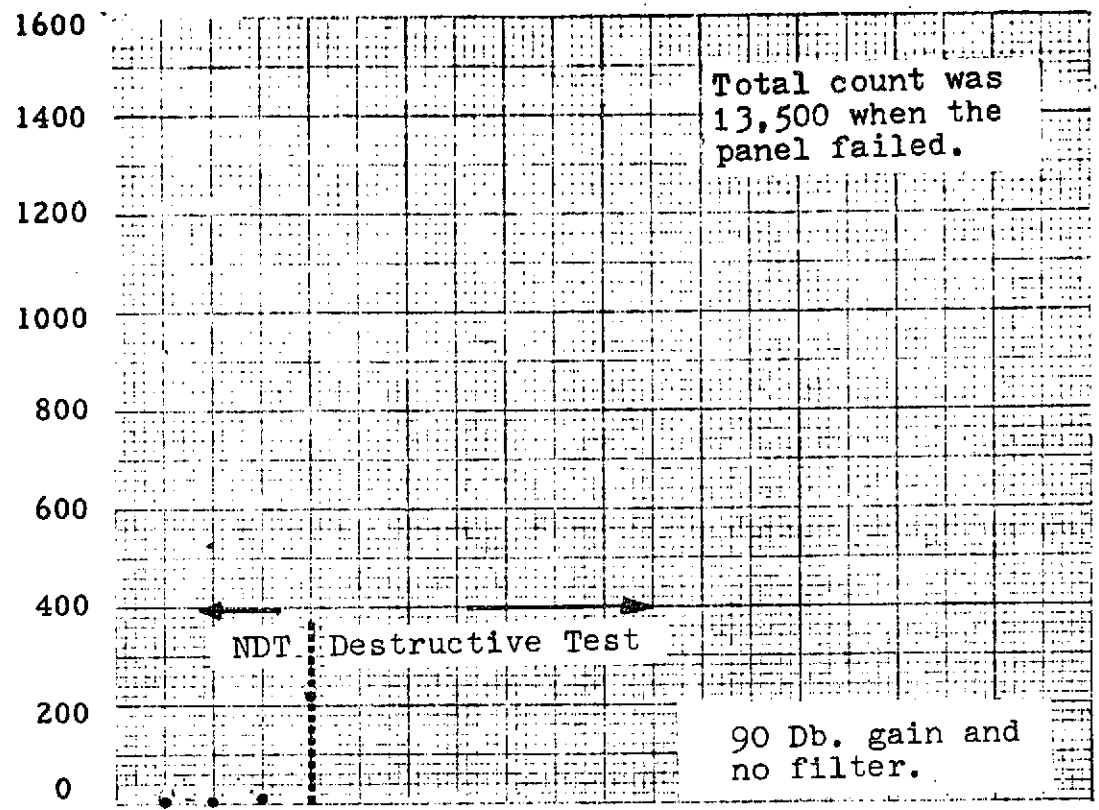
REPRODUCIBILITY OF THE ORIGINAL PAGE IS POOR

FIGURE C-43

Panel No. C-21C/A "

Summation $\times 10^{-1}$

A E



0 689 1378 2067 2756 3445 4134 4823 5512 6201 6890 $\times 10^4$
 0 (1000) (2000) (3000) (4000) (5000) (6000) (7000) (8000) (9000) (10,000)

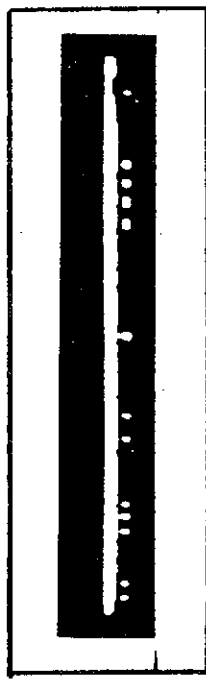
Pressure - N/M^2 (PSI)

HNDT (After AE)

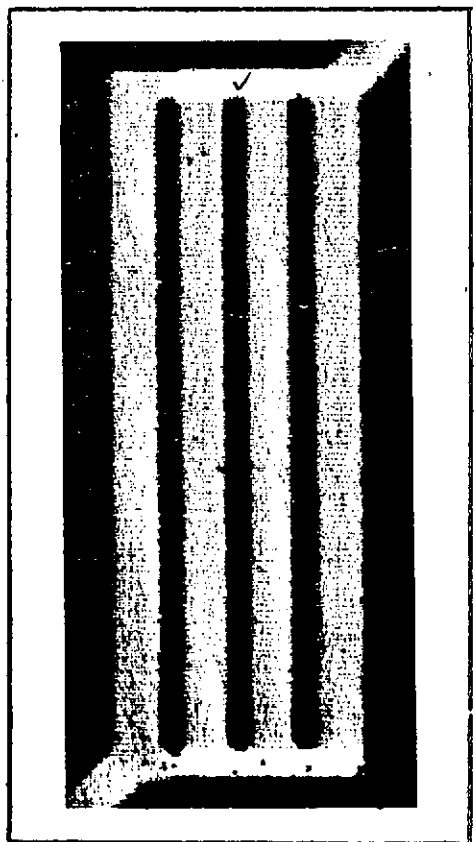


Press. $6.9 \times 10^5 N/M^2$
 (100 PSI)

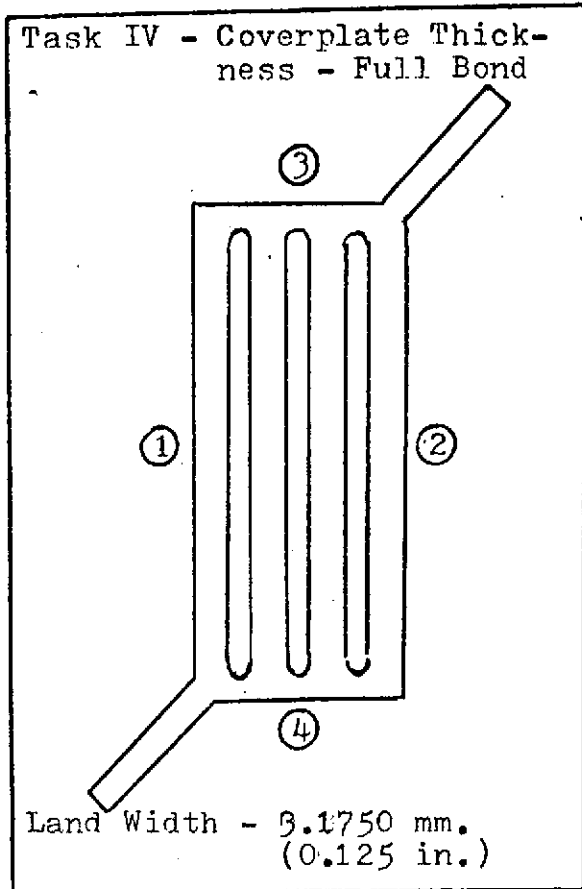
AE
 FLAW LOCATOR
 CENTER LAND



UT



ELECTROFORMED PANEL NO. C-04C



BASEPLATE

MATERIAL: OFHC Copper
CENTER LAND FLATNESS VARIATION:
0.002 in. (0.0508 mm.)

THICKNESS:	MM.	INCHES
①	6.4465	0.2538
②	6.4567	0.2542
③	6.4719	0.2548
④	6.4033	0.2521

COVERPLATE

MATERIAL: Electroformed Copper

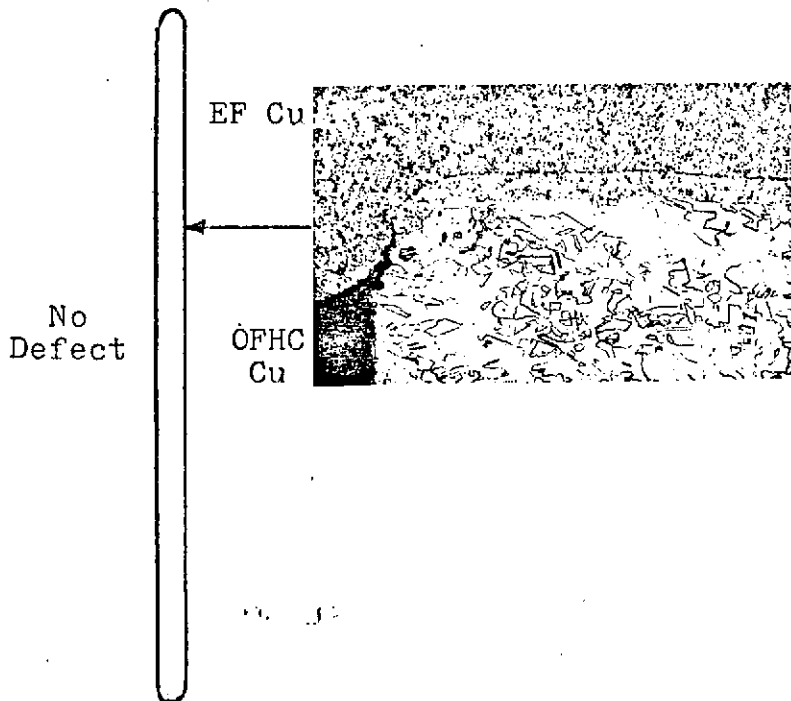
THICKNESS:	MM.	INCHES
①	0.7620	0.0300
②	0.7036	0.0277
③	0.6379	0.0259
④	0.7772	0.0306

PRESSURE REQUIRED TO FAIL BOND:

Panel failed at a pressure of
 2.42×10^7 N/m² (3,500 psi).

CENTER LAND DEFECT.

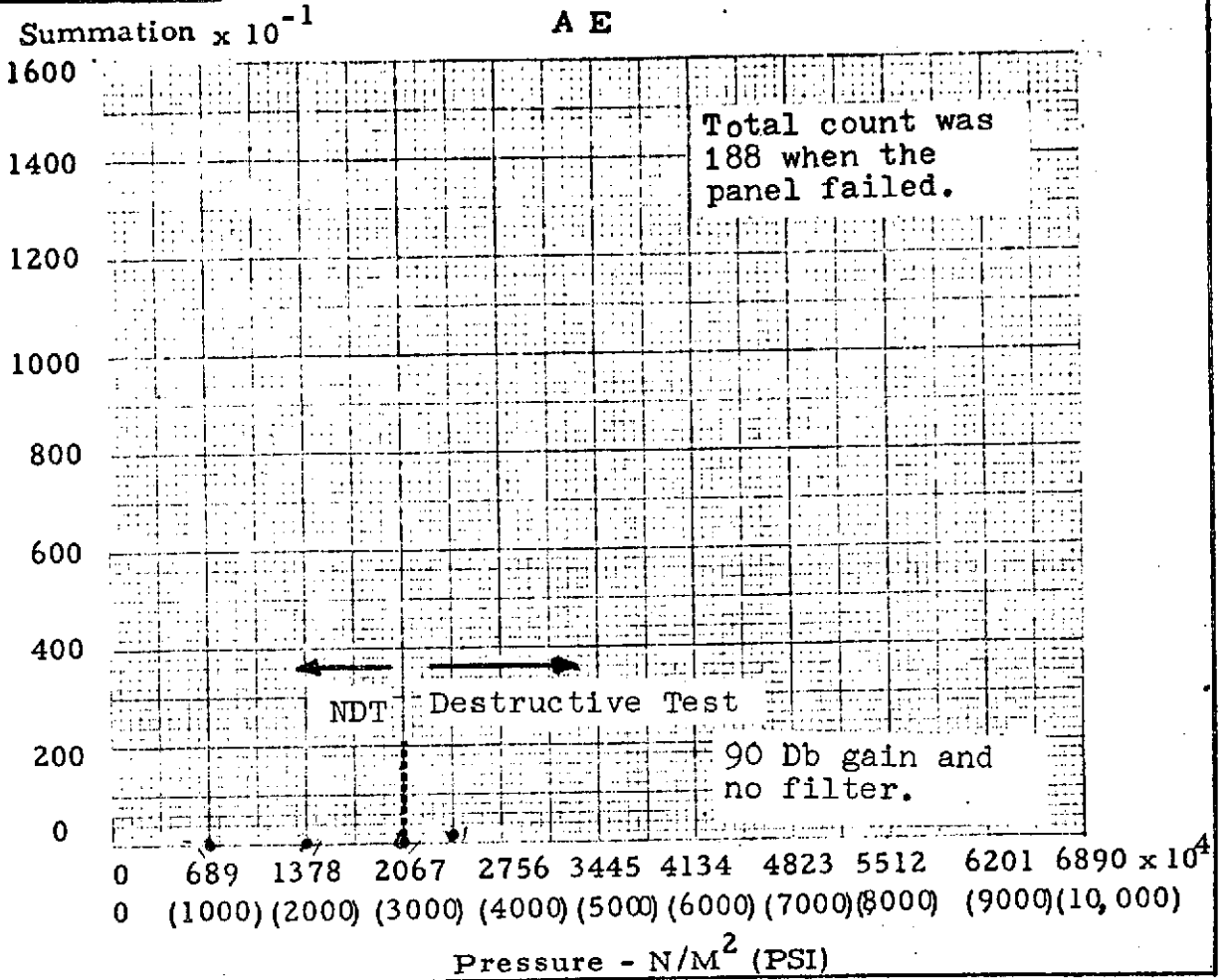
METALLOGRAPHIC ANALYSIS:



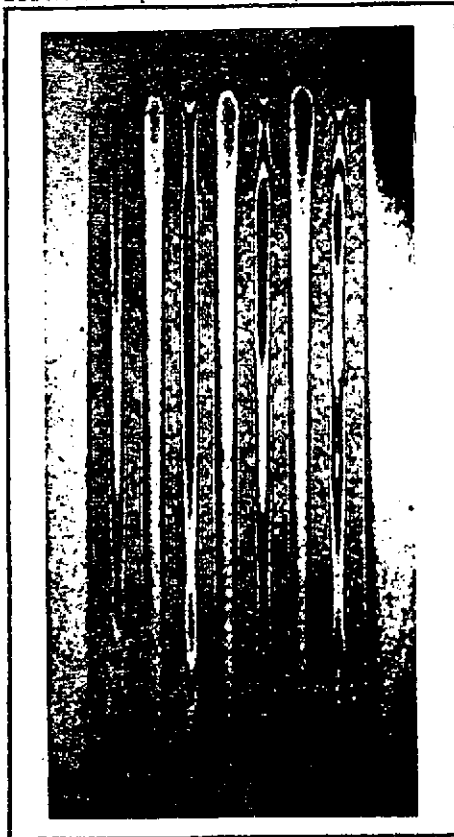
Section of full bond which did not fail. Note start of failure at edge of land. Magnification 100X.

FIGURE C-44

Panel No. C-4C

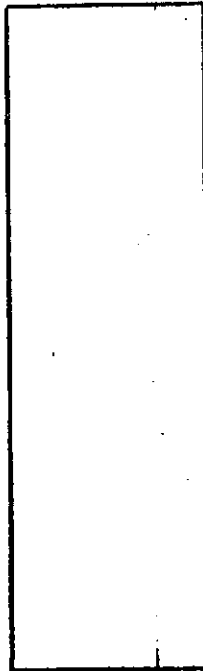


HNDT (After AE)



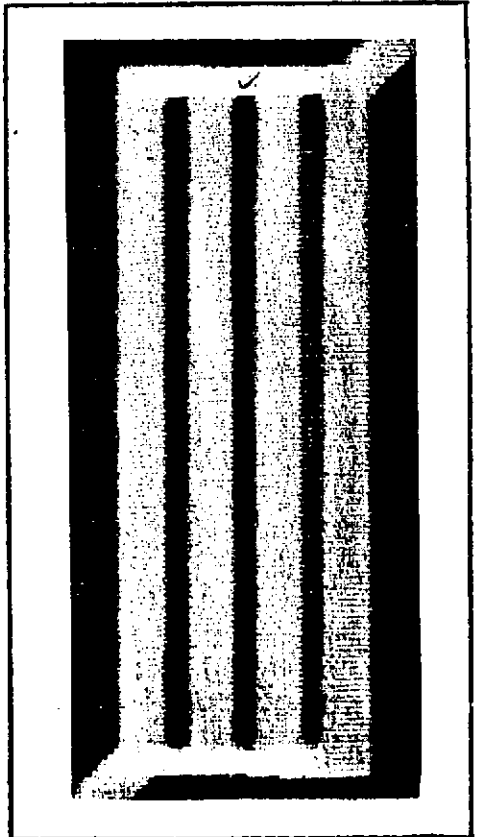
Press. 20.7×10^5 N/M^2
(300 PSI)

AE
FLAW LOCATOR
CENTER LAND

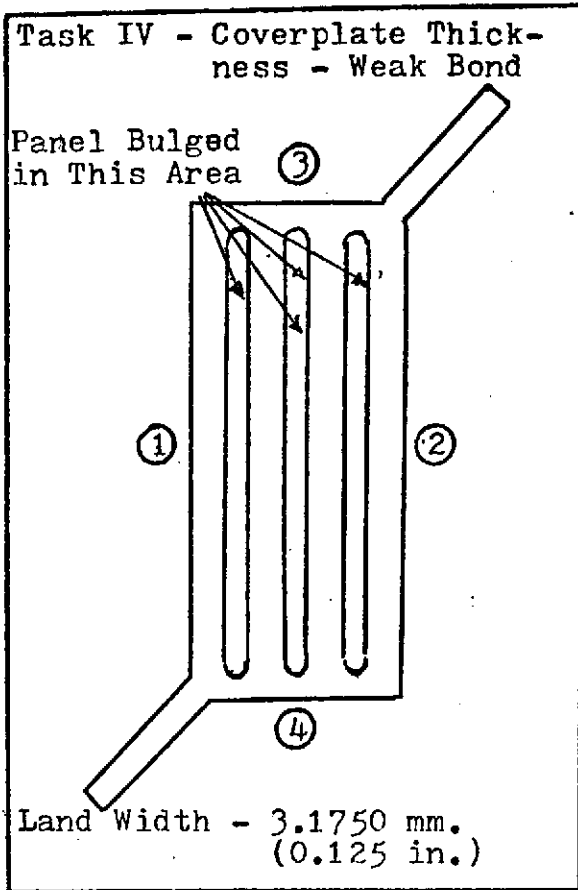


157

UT



ELECTROFORMED PANEL NO. C-22C "A"



BASEPLATE

MATERIAL: OFHC Copper

CENTER LAND FLATNESS VARIATION:
0.0015 in. (0.0381 mm.)

THICKNESS:	MM.	INCHES
①	6.3830	0.2513
②	6.4084	0.2523
③	6.4287	0.2531
④	6.4211	0.2528

COVERPLATE

MATERIAL: Electroformed Copper

THICKNESS:	MM.	INCHES
①	0.7239	0.0285
②	0.6960	0.0274
③	0.7341	0.0289
④	0.6985	0.0275

PRESSURE REQUIRED TO FAIL BOND:

Panel failed at a pressure of
 $0.97 \times 10^7 \text{ N/m}^2$ (1,400 psi).

CENTER LAND DEFECT

METALLOGRAPHIC ANALYSIS:

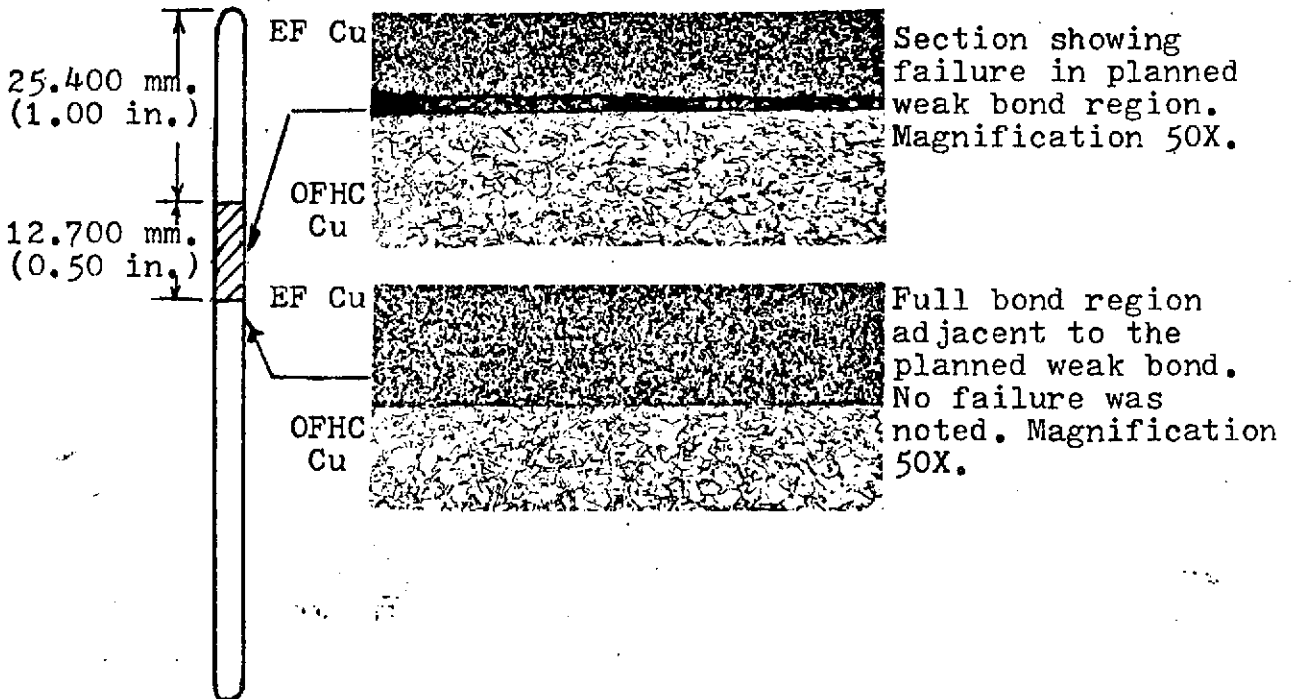
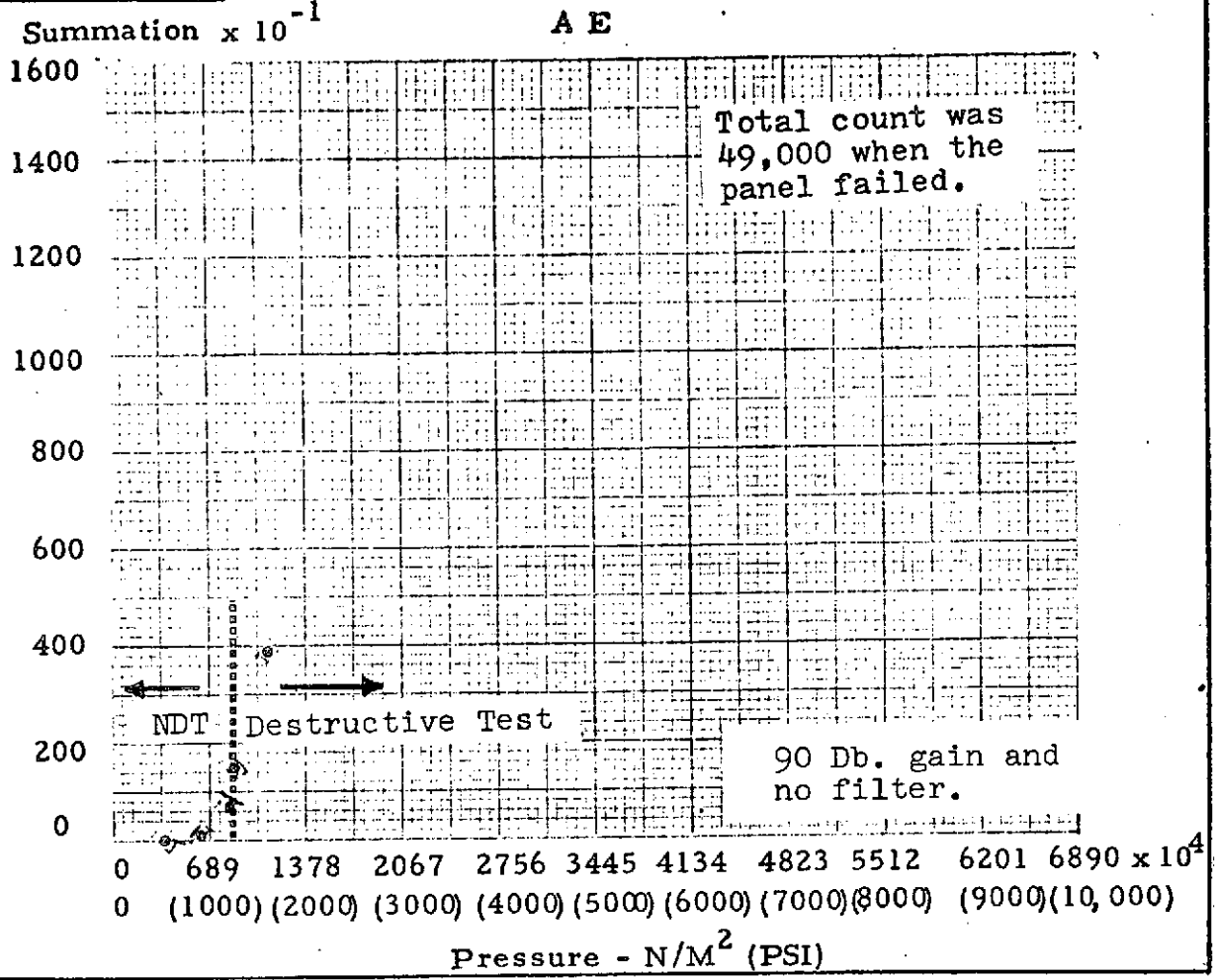
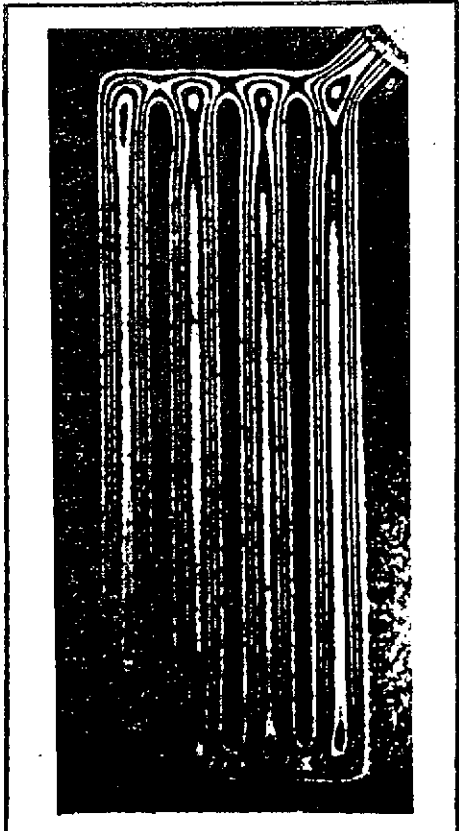


FIGURE C-45

Panel No. C-22'A''

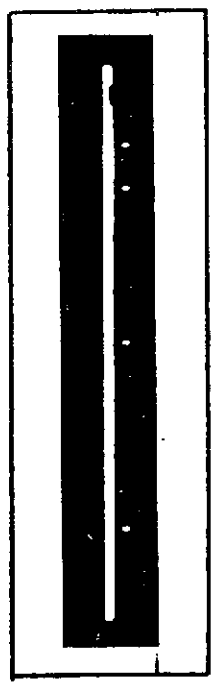


HNDT (After AE)

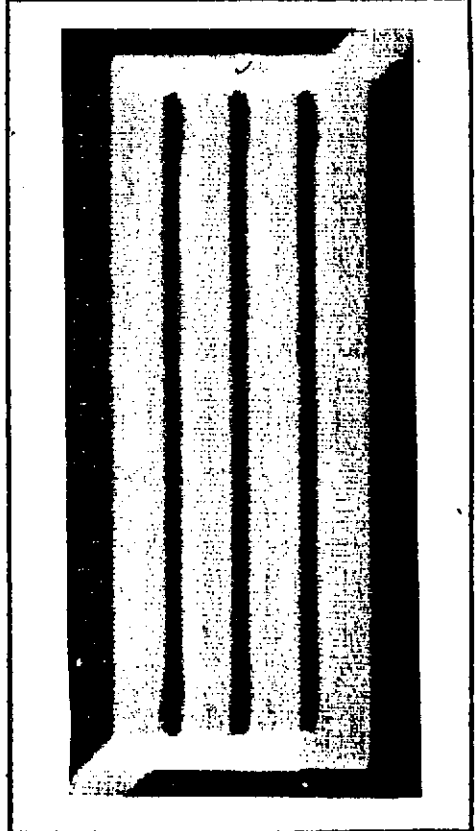


Press. 6.9×10^5 N/M^2
(100 PSI)

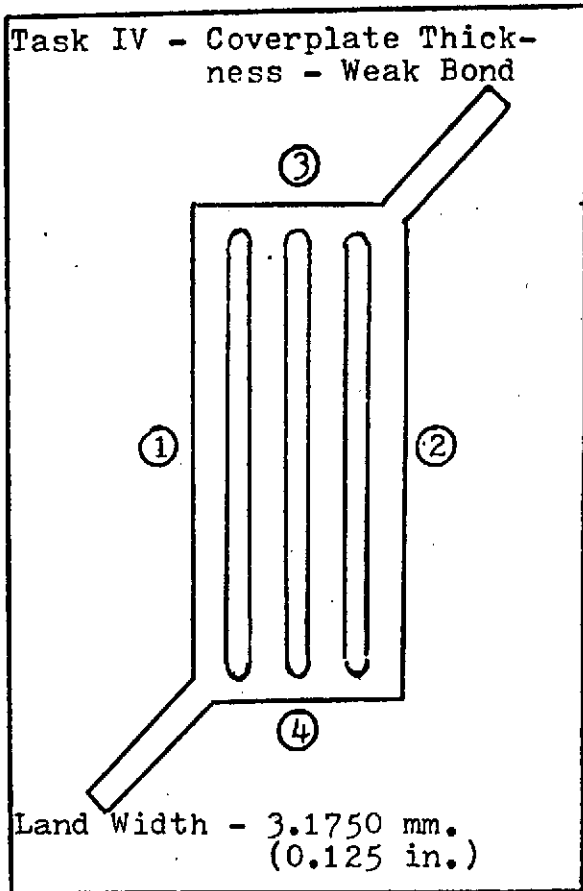
AE
FLAW LOCATOR
CENTER LAND



UT



ELECTROFORMED PANEL NO. C-23C "A"



BASEPLATE

MATERIAL: OFHC Copper

CENTER LAND FLATNESS VARIATION:
0.0025 in. (0.0635 mm.)

THICKNESS:	MM.	INCHES
①	6.5227	0.2568
②	6.5253	0.2569
③	6.4821	0.2552
④	6.5608	0.2583

COVERPLATE

MATERIAL: Electroformed Copper

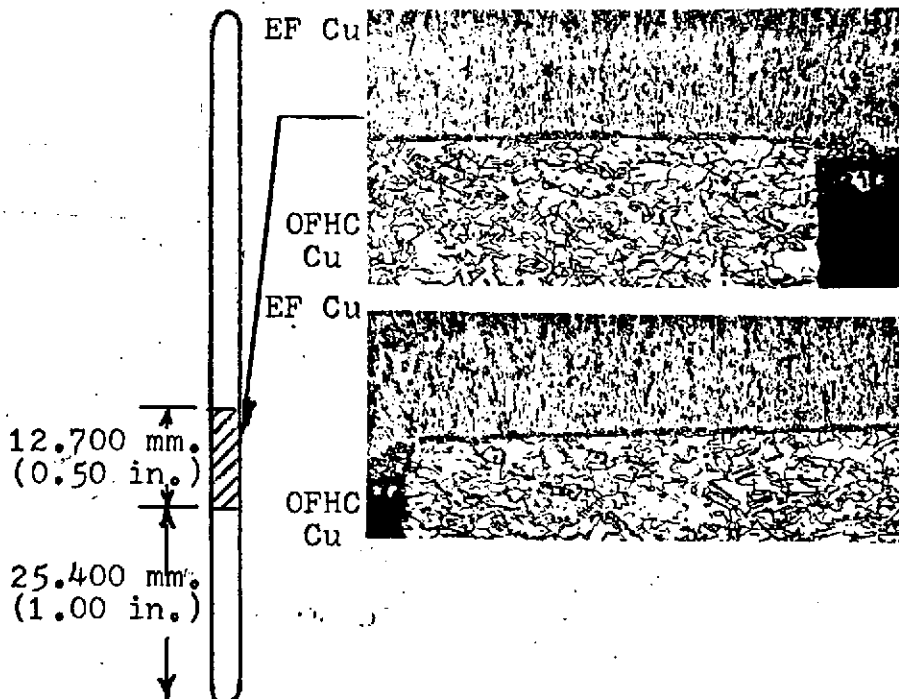
THICKNESS:	MM.	INCHES
①	0.8001	0.0315
②	0.7417	0.0292
③	0.7671	0.0302
④	0.7493	0.0295

PRESSURE REQUIRED TO FAIL BOND:

Panel failed at a pressure of
 1.59×10^7 N/m² (2,300 psi).

CENTER LAND DEFECT

METALLOGRAPHIC ANALYSIS:

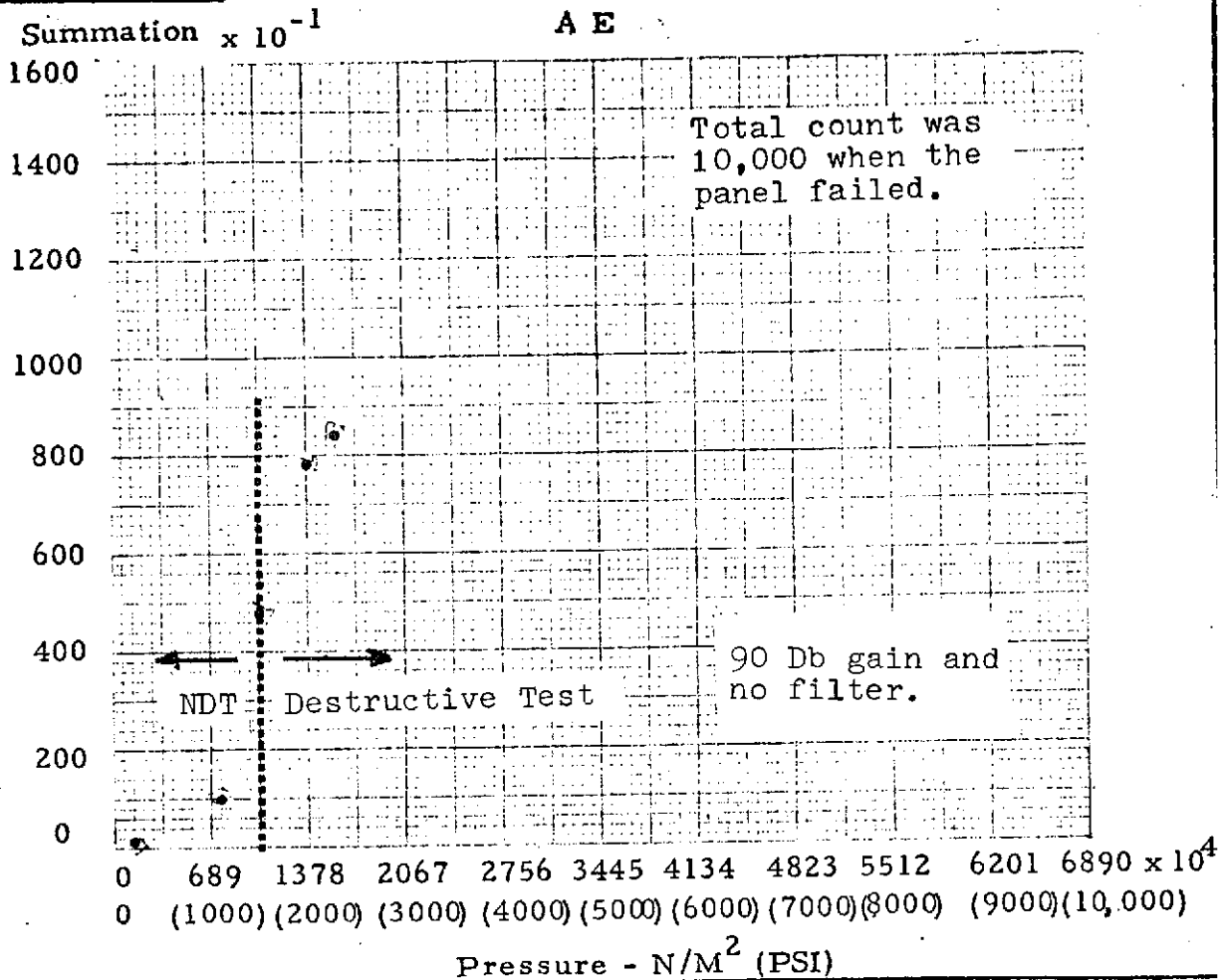


Section of the planned weak bond showing no failure. Coverplate failed at too low a pressure to fail bond. Magnification 50X.

Section of planned full bond on Land 3 adjacent to the Land 2 weak bond. Magnification 50X.

FIGURE C-46

Panel No. C-23C "A"



HNDT (Before AE)

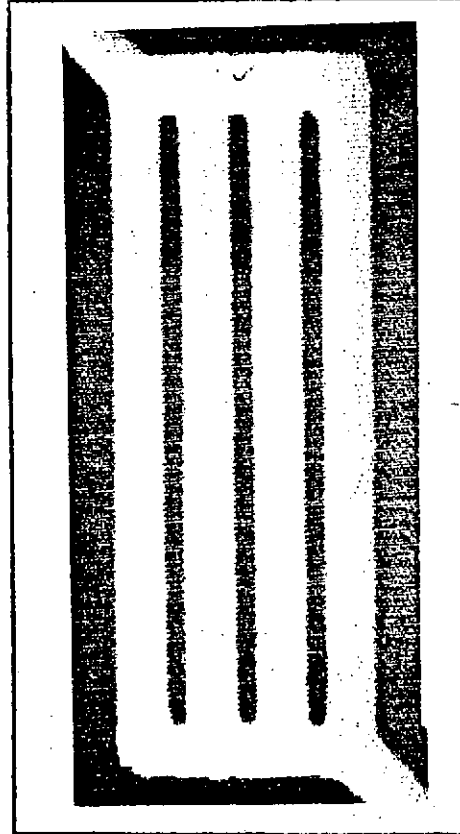


Press. $6.9 \times 10^5 N/M^2$
(100 PSI)

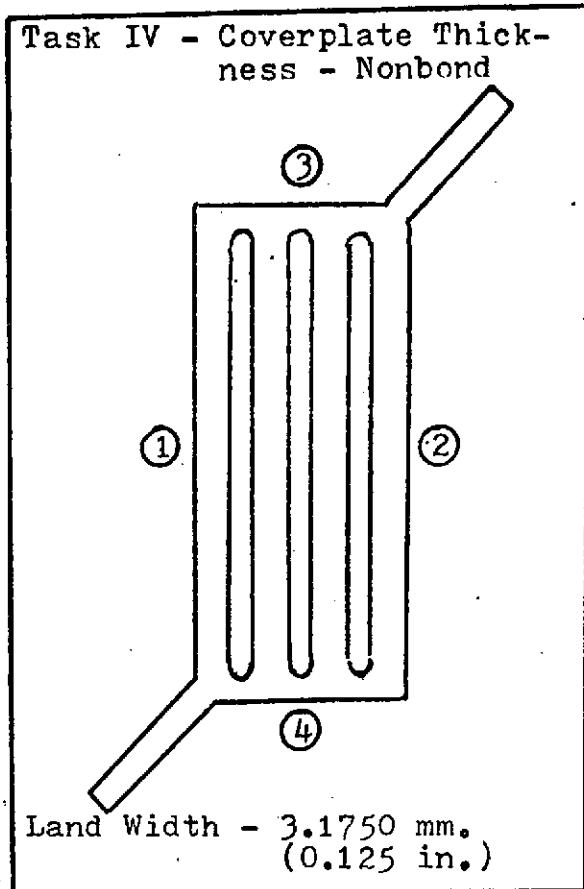
AE
FLAW LOCATOR
CENTER LAND



UT



ELECTROFORMED PANEL NO. C-24C "A"



BASEPLATE

MATERIAL: OFHC Copper

CENTER LAND FLATNESS VARIATION:
0.001 in. (0.0254 mm.)

THICKNESS:	MM.	INCHES
①	6.4770	0.2550
②	6.4821	0.2552
③	6.4897	0.2555
④	6.5024	0.2560

COVERPLATE

MATERIAL: Electroformed Copper

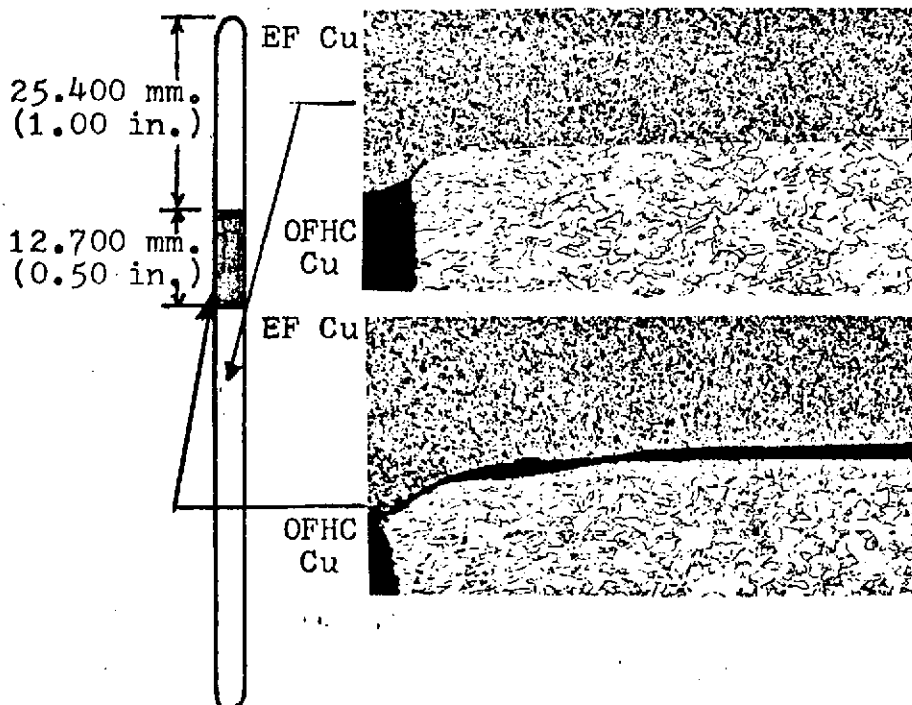
THICKNESS:	MM.	INCHES
①	0.7163	0.0282
②	0.7239	0.0285
③	0.7366	0.0290
④	0.6934	0.0273

PRESSURE REQUIRED TO FAIL BOND:

Panel failed at a pressure of
 $0.76 \times 10^7 \text{ N/m}^2$ (1,100 psi).

CENTER LAND DEFECT.

METALLOGRAPHIC ANALYSIS:

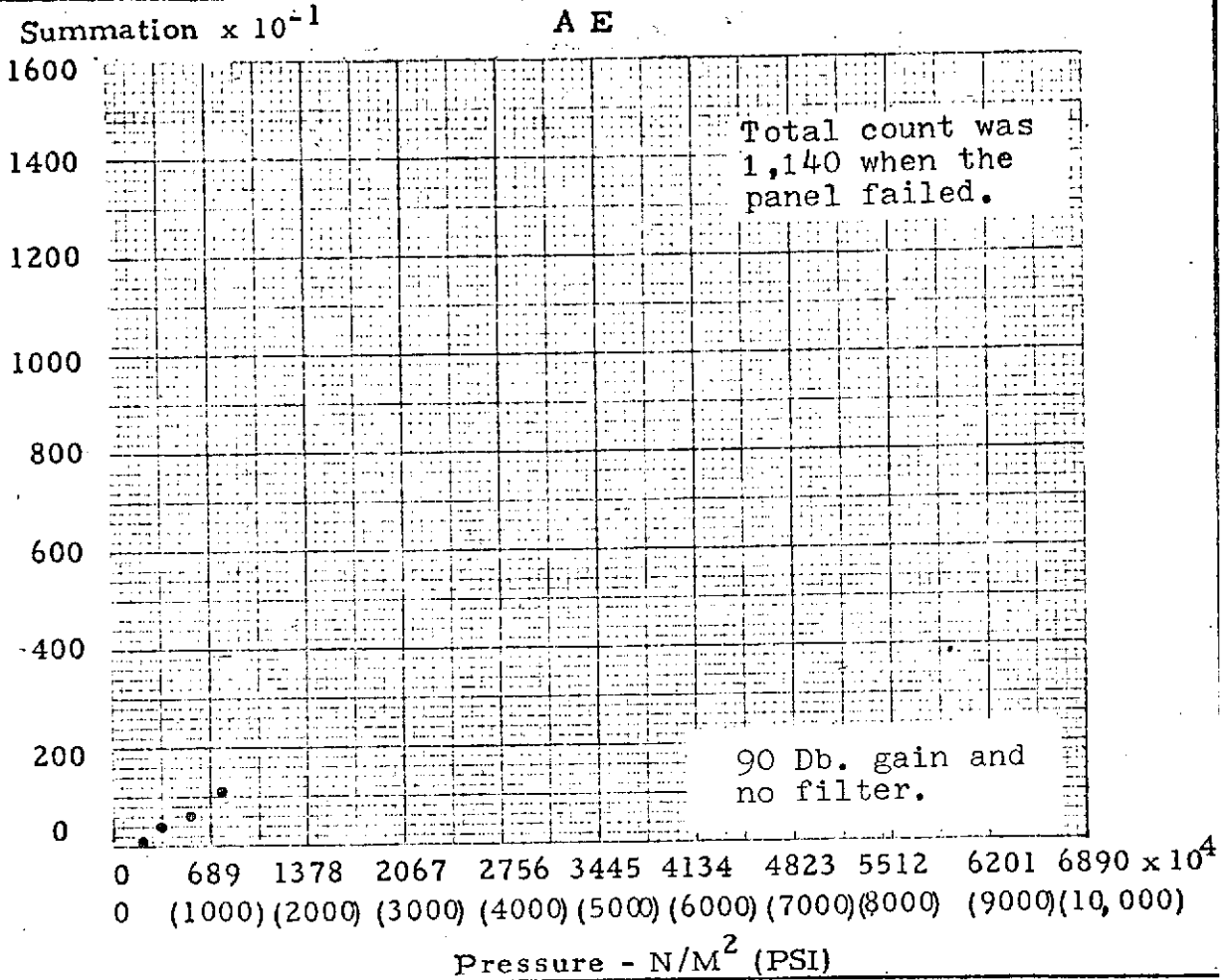


Full bond area next to planned nonbond. Note initiation of failure at land edge. Magnification 50X.

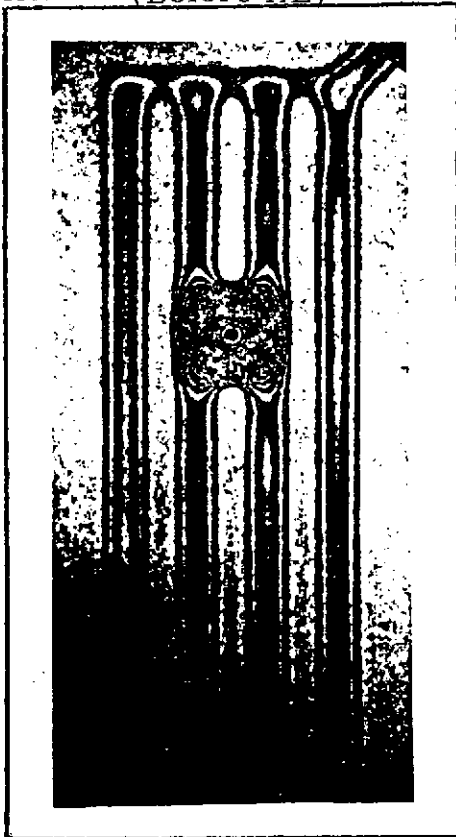
Separation of the planned nonbond; No metal disturbance was noted. Magnification 50X.

FIGURE C-47

Panel No. C-24C



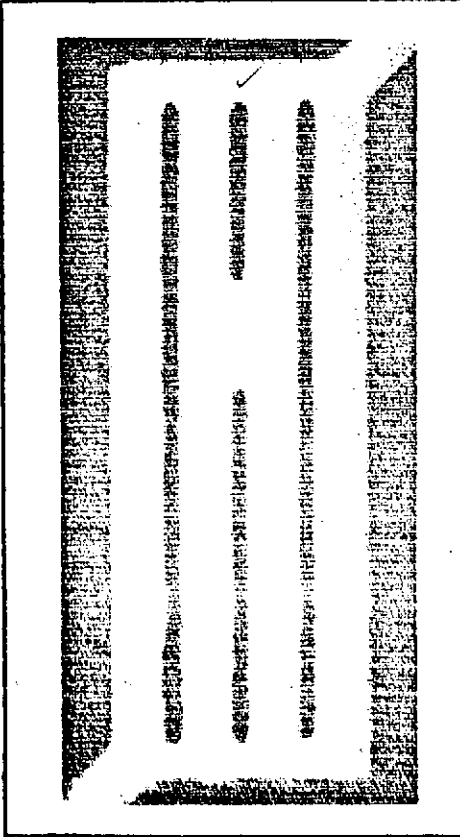
HNDT (Before AE)



AE
FLAW LOCATOR
CENTER LAND

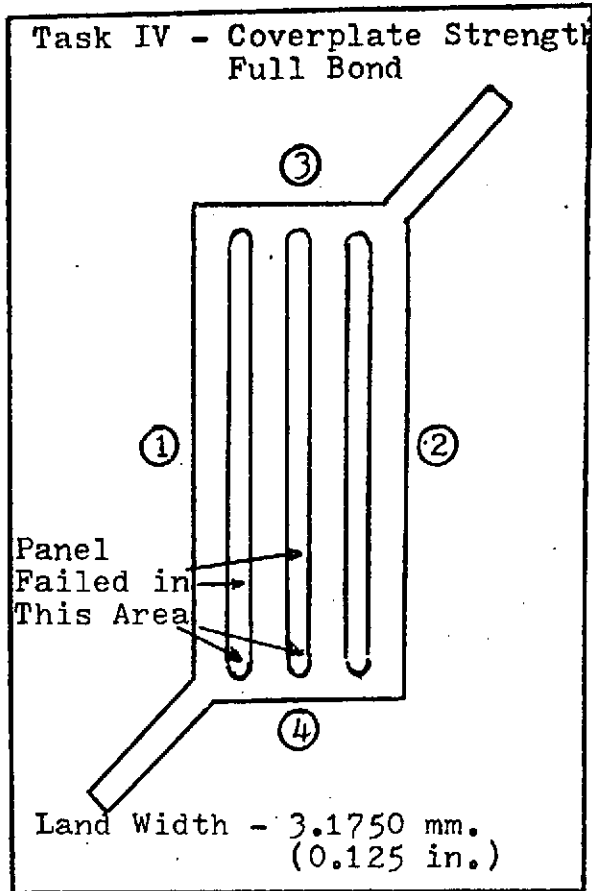


UT



Press. 3.45×10^5 N/M^2
(50 PSI)

ELECTROFORMED PANEL NO. C-12C "A"



BASEPLATE

MATERIAL: OFHC Copper

CENTER LAND FLATNESS VARIATION:
0.003 in. (0.0762 mm.)

THICKNESS:	MM.	INCHES
①	5.9665	0.2349
②	5.9639	0.2348
③	5.9588	0.2346
④	5.9258	0.2333

COVERPLATE

MATERIAL: Electroformed Copper

THICKNESS:	MM.	INCHES
①	1.2040	0.0474
②	1.1811	0.0465
③	1.1760	0.0463
④	1.2294	0.0484

PRESSURE REQUIRED TO FAIL BOND:

Panel failed at a pressure of
 $3.80 \times 10^7 \text{ N/m}^2$ (5,500 psi).

CENTER LAND DEFECT

METALLOGRAPHIC ANALYSIS:

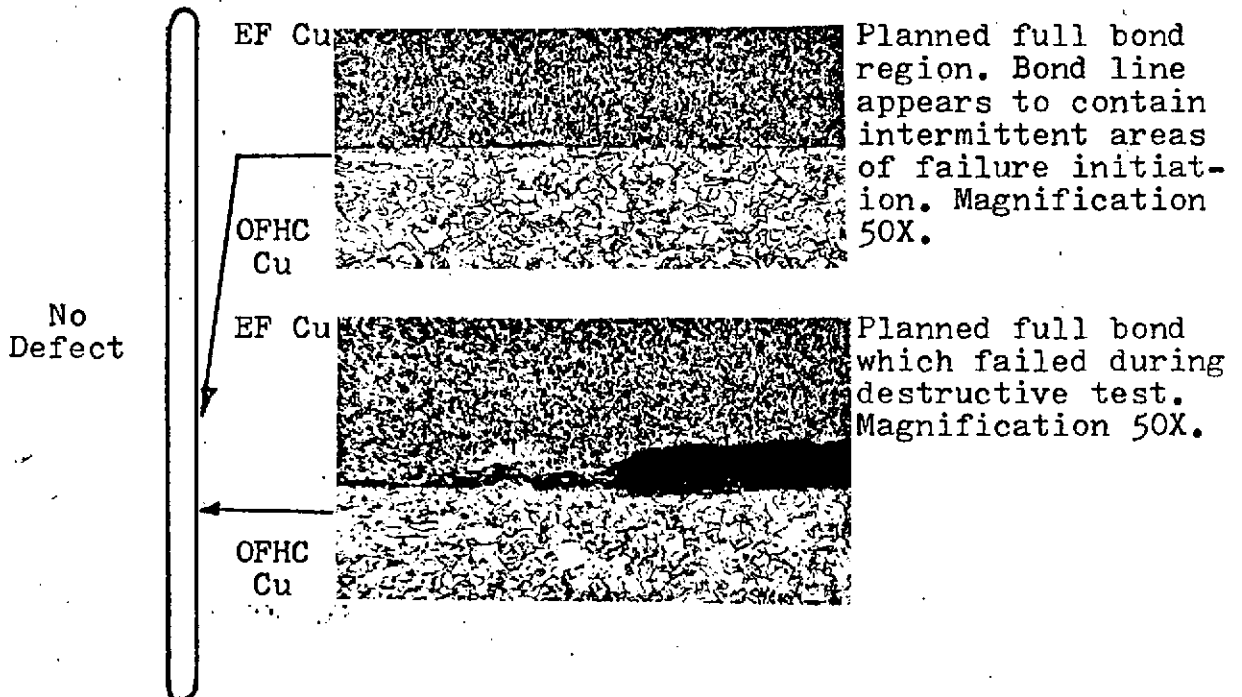
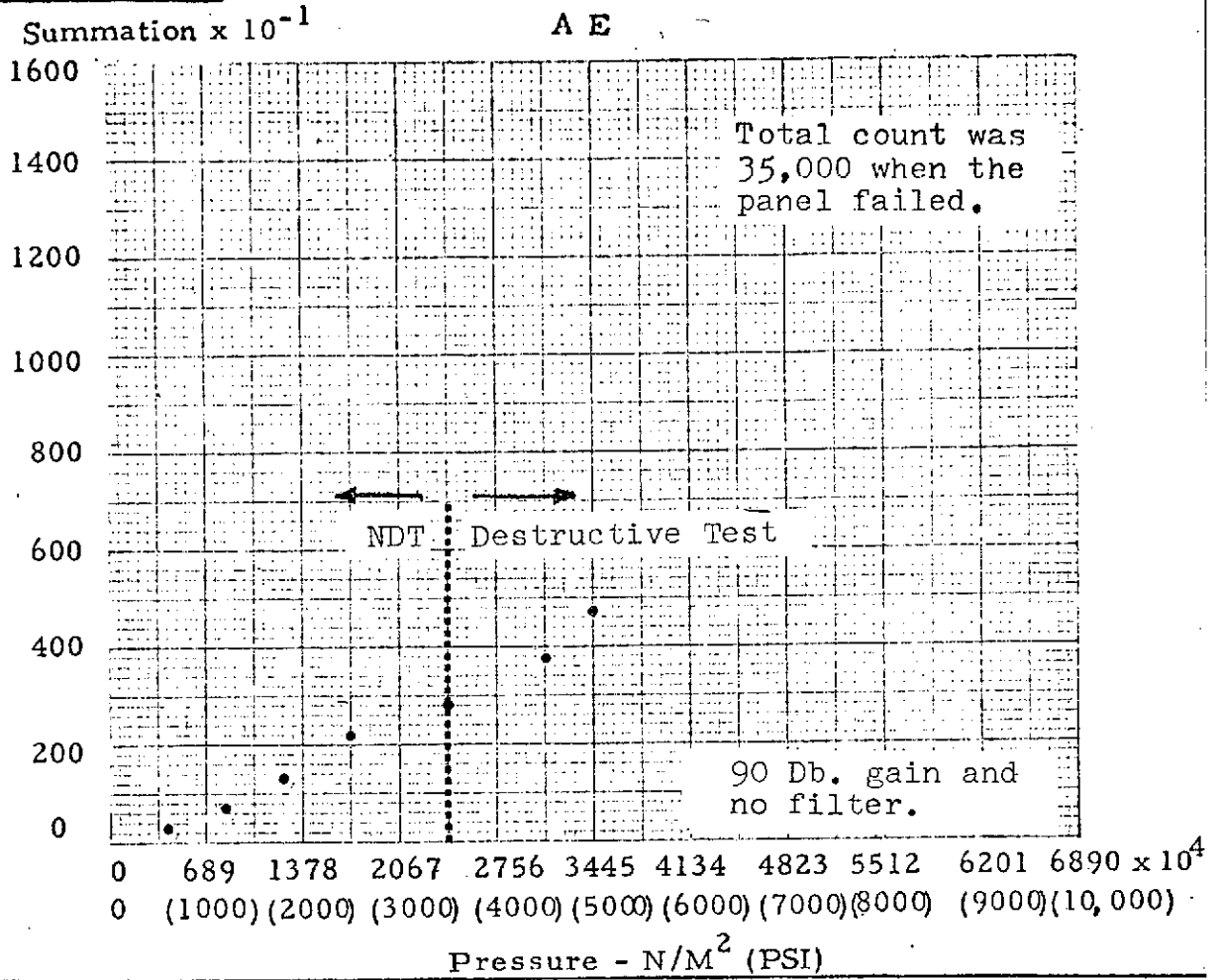
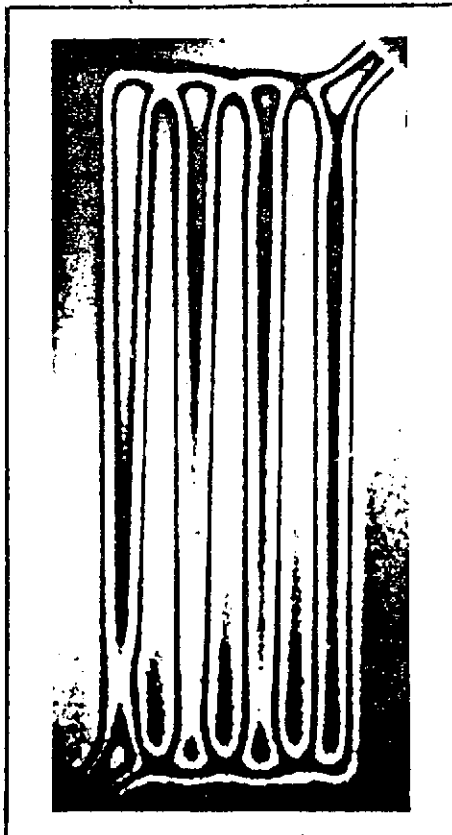


FIGURE C-48

Panel No. C-12C



HNDT (Before AE)



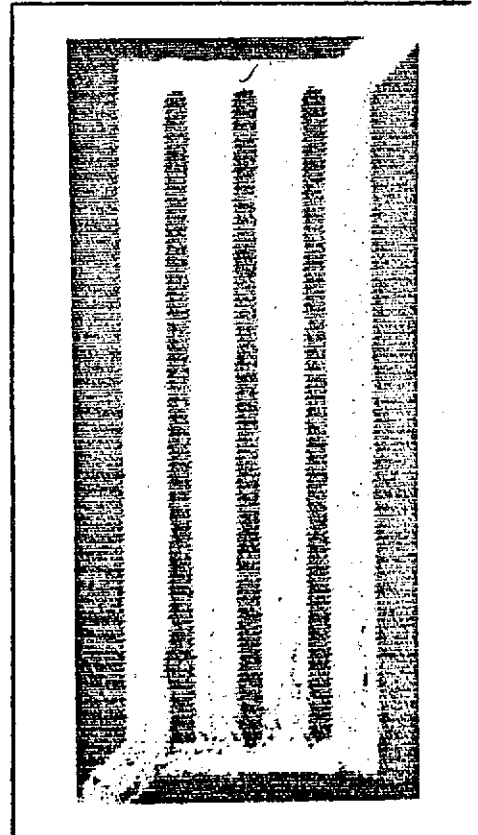
Press. 13.8×10^5 N/M^2
(200 PSI)

AE
FLAW LOCATOR
CENTER LAND

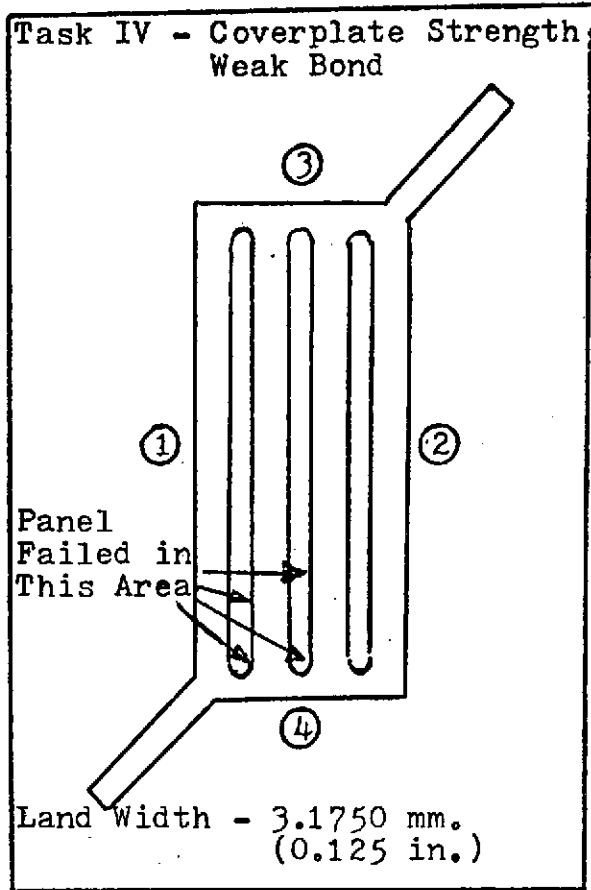


165

UT



ELECTROFORMED PANEL NO. C-25C "A"



BASEPLATE

MATERIAL: DFHC Copper
 CENTER LAND FLATNESS VARIATION:
 0.003 in. (0.0762 mm.)

THICKNESS:	MM.	INCHES
①	6.1570	0.2424
②	6.1468	0.2420
③	6.1722	0.2430
④	6.2026	0.2442

COVERPLATE

MATERIAL: Electroformed Copper

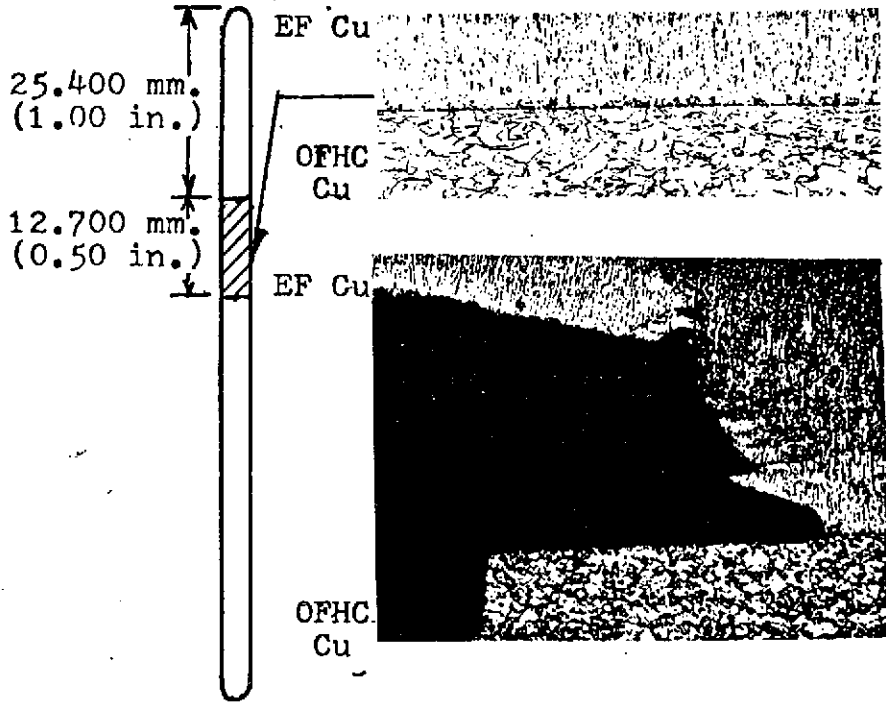
THICKNESS:	MM.	INCHES
①	1.2243	0.0482
②	1.2141	0.0478
③	1.1862	0.0467
④	1.1938	0.0470

PRESSURE REQUIRED TO FAIL BOND:

Panel failed at a pressure of
 $3.93 \times 10^7 \text{ N/m}^2$ (5,700 psi).

CENTER LAND DEFECT

METALLOGRAPHIC ANALYSIS:

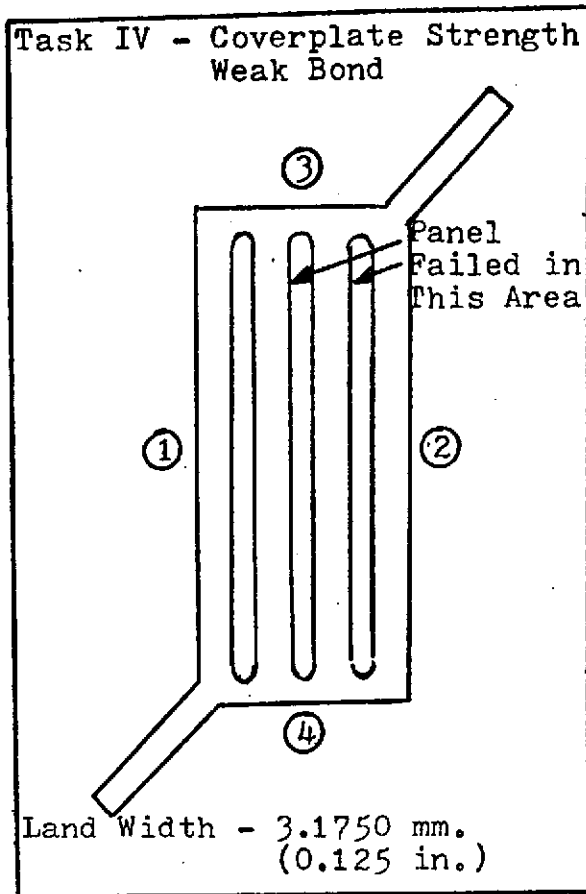


Section from planned weak bond indicates a full bond actually was obtained. No signs of failure are noted. Magnification 500X.

Panel failed in lower part of Land 1 and the manifold. Note failure occurred through an unplanned weak bond on one side of the land and tore through the copper coverplate. Magnification 32X.

FIGURE C-49

ELECTROFORMED PANEL NO. C-26C "A"



BASEPLATE

MATERIAL: OFHC Copper

CENTER LAND FLATNESS VARIATION:
None detected.

THICKNESS:	MM.	INCHES
①	6.0706	0.2390
②	6.0706	0.2390
③	6.0884	0.2397
④	6.0655	0.2388

COVERPLATE

MATERIAL: Electroformed Copper

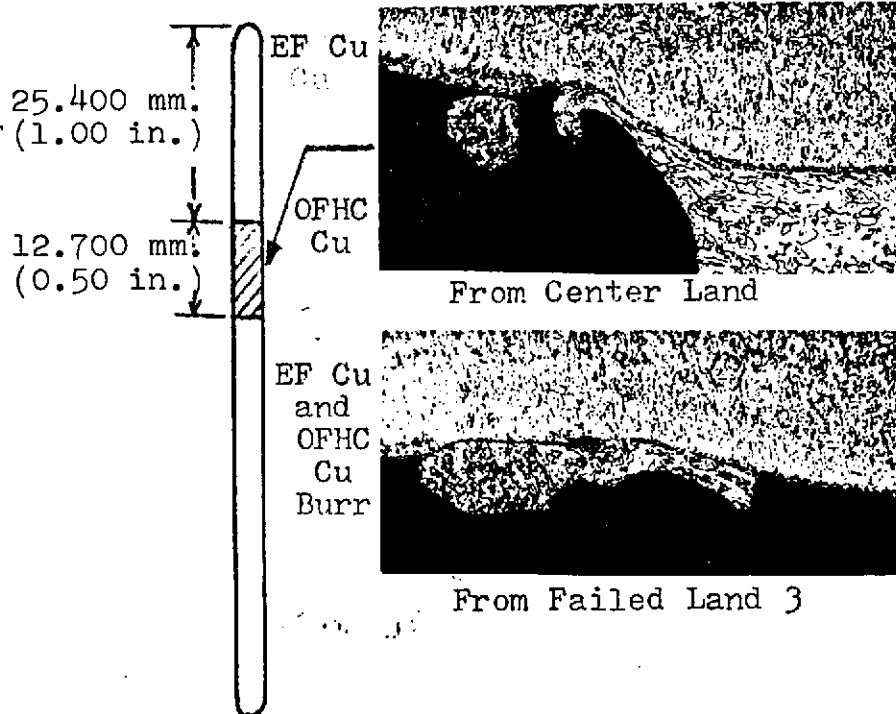
THICKNESS:	MM.	INCHES
①	1.2040	0.0474
②	1.2268	0.0483
③	1.1938	0.0470
④	1.2141	0.0478

PRESSURE REQUIRED TO FAIL BOND:

Panel failed at a pressure of $5.18 \times 10^7 \text{ N/m}^2$ (7,500 psi).

CENTER LAND DEFECT

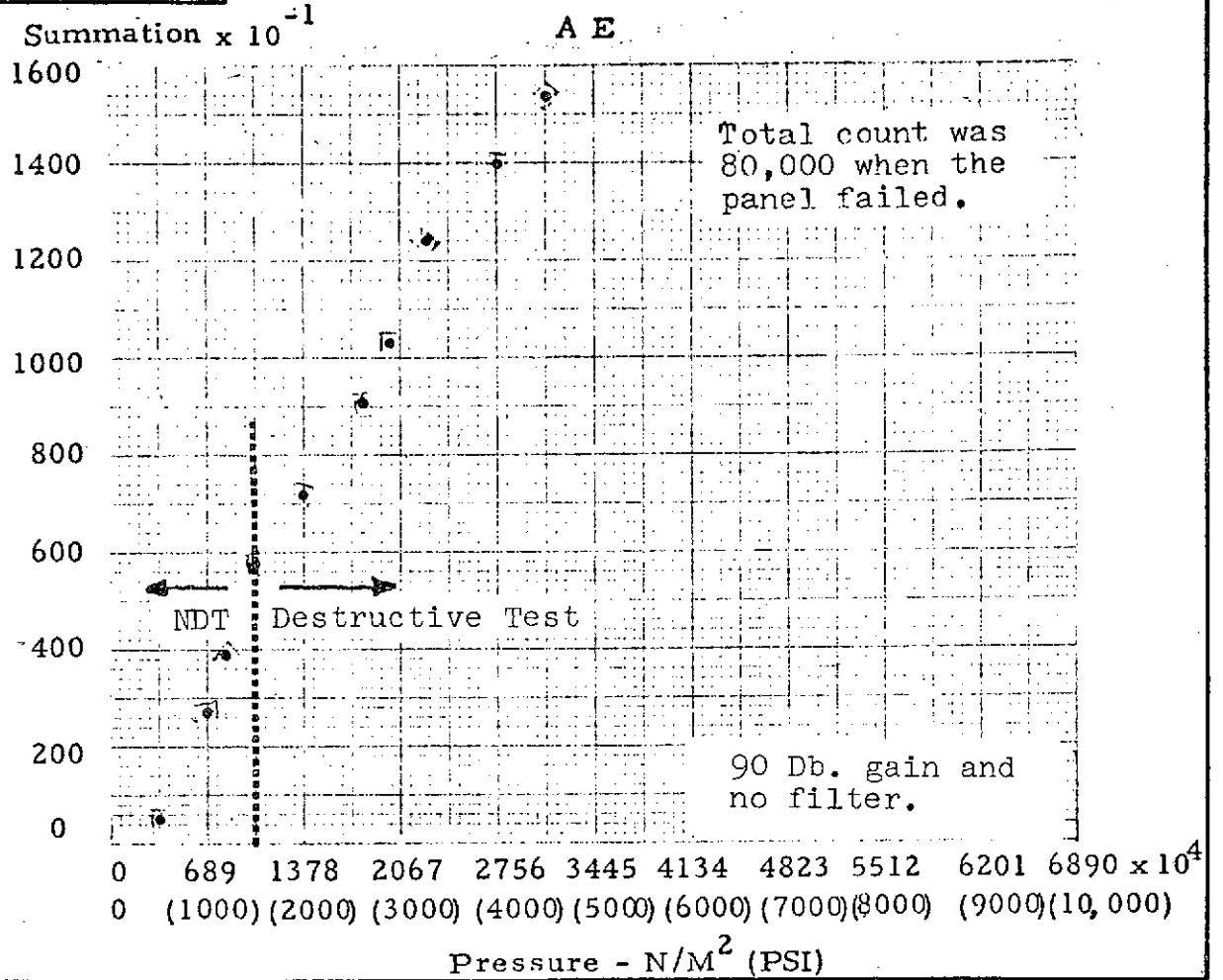
METALLOGRAPHIC ANALYSIS:



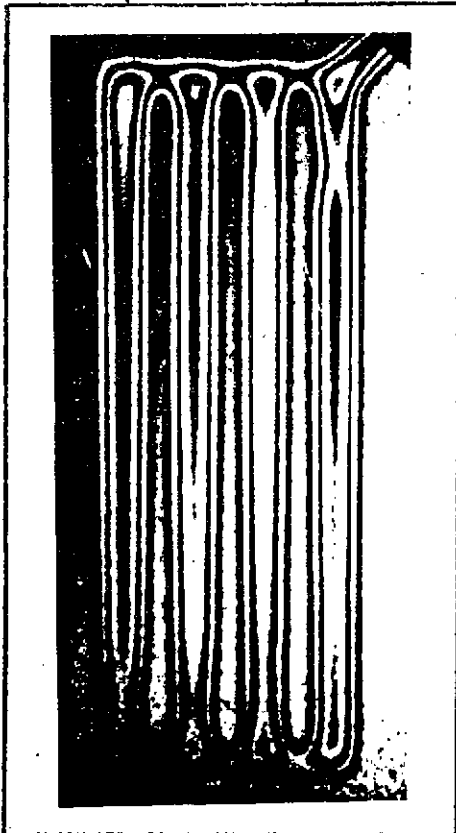
Because of a large unplanned nonbond noted on the original panel, the baseplate was machined to remove the old cover. The baseplate had burrs from the machining which were not completely removed by pickling. When the new coverplate was fabricated, the burrs failed under pressure and gave the false conception of a weak bond. The planned weak bond did not fail nor show any evidence of failing. Magnification 50X.

FIGURE C-50

Panel No. C-26C "A"

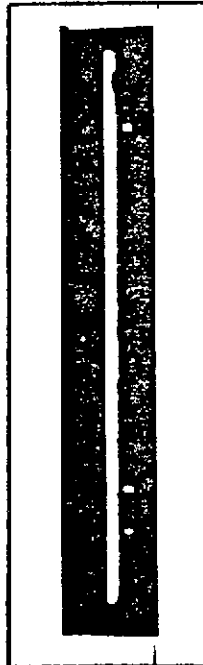


HNDT (Before AE)



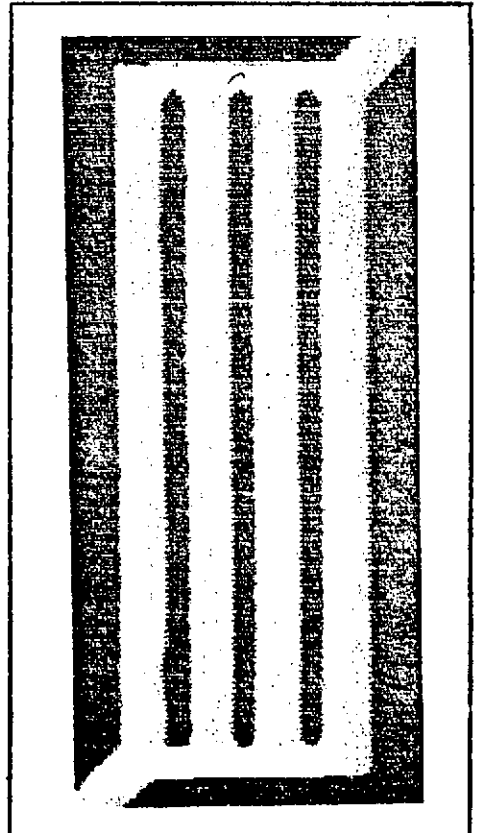
Press. $13.8 \times 10^5 N/M^2$
(200 PSI)

A E
FLAW LOCATOR
CENTER LAND

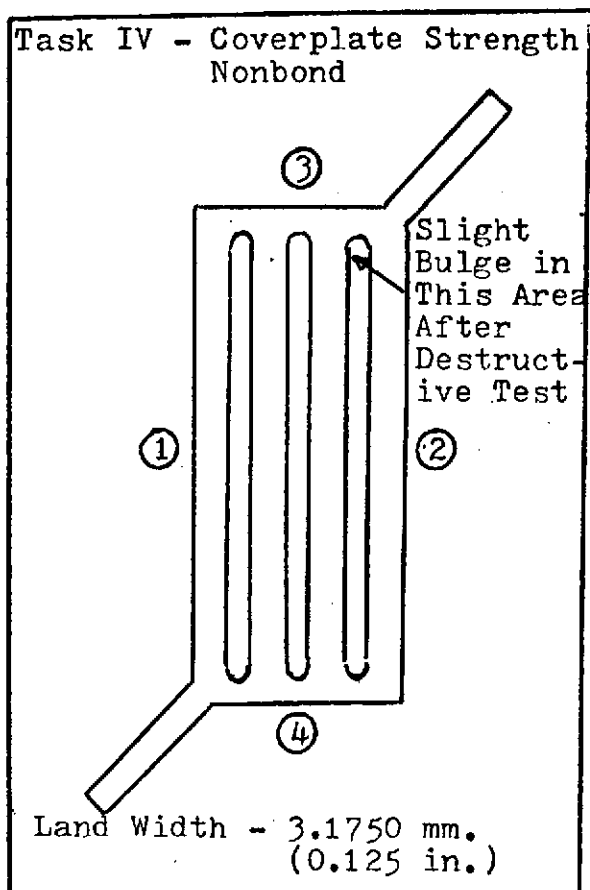


169

UT



ELECTROFORMED PANEL NO. C-27C



BASEPLATE

MATERIAL: OFHC Copper
 CENTER LAND FLATNESS VARIATION:
 0.001 in. (0.0254 mm.)

THICKNESS:	MM.	INCHES
①	6.4160	0.2526
②	6.4110	0.2524
③	6.3856	0.2514
④	6.4110	0.2524

COVERPLATE

MATERIAL: Electroformed Copper

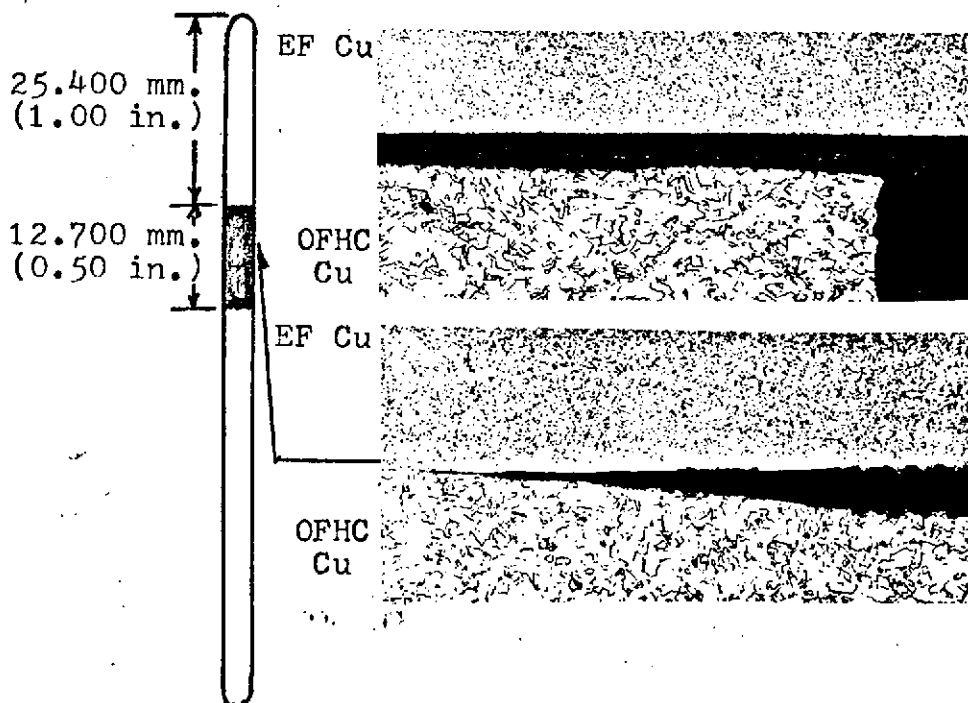
THICKNESS:	MM.	INCHES
①	1.2929	0.0509
②	1.2751	0.0502
③	1.2878	0.0507
④	1.2954	0.0510

PRESSURE REQUIRED TO FAIL BOND:

Panel failed at a pressure of
 $1.10 \times 10^7 \text{ N/m}^2$ (1,600 psi).

CENTER LAND DEFECT

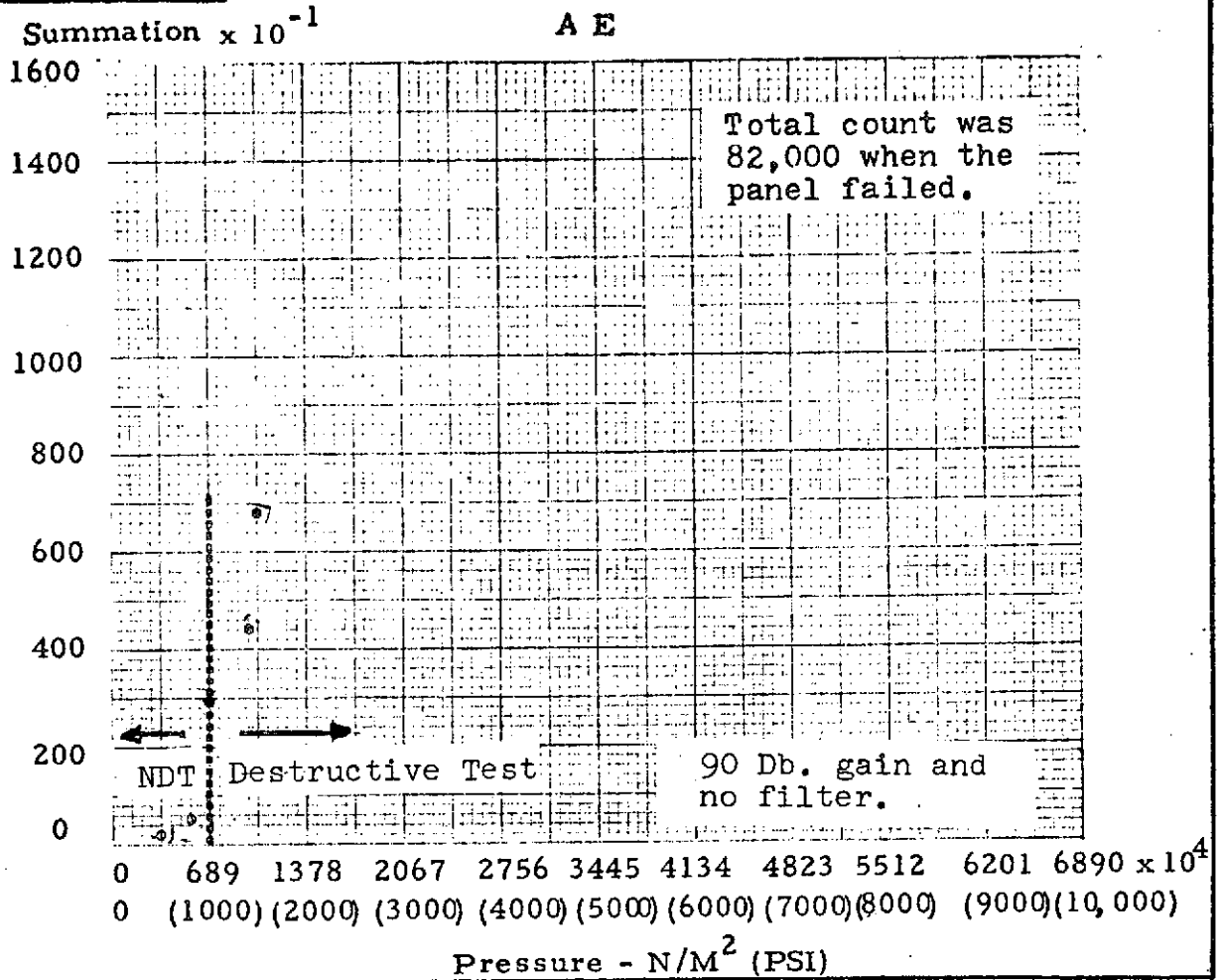
METALLOGRAPHIC ANALYSIS:



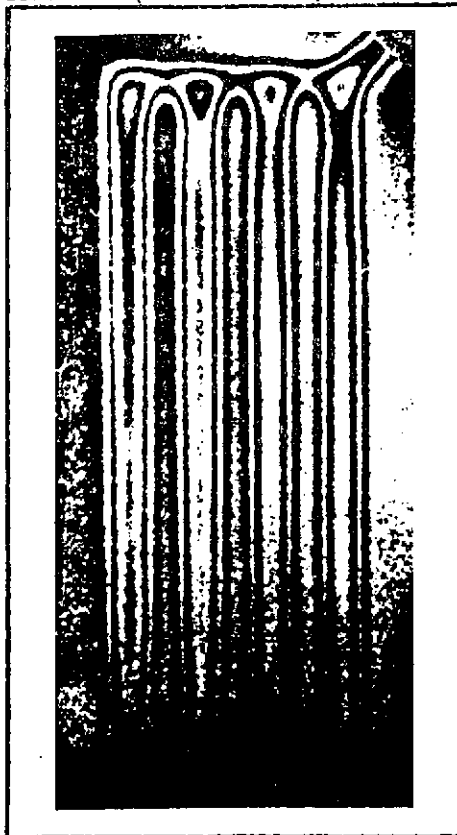
Section of an unplanned weak bond at the top manifold end of Land 3. Lack of metal disturbance indicates very weak bond. Magnification 50X.

Section of the planned nonbond. Metal disturbance indicates some tack bonding had occurred. Magnification 50X.

FIGURE C-51

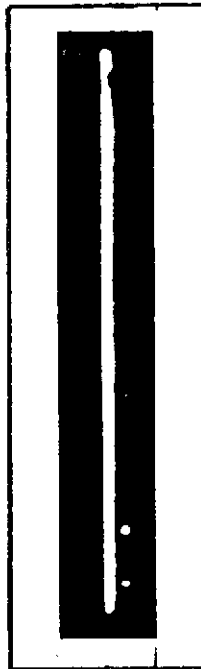


HNDT (Before AE)



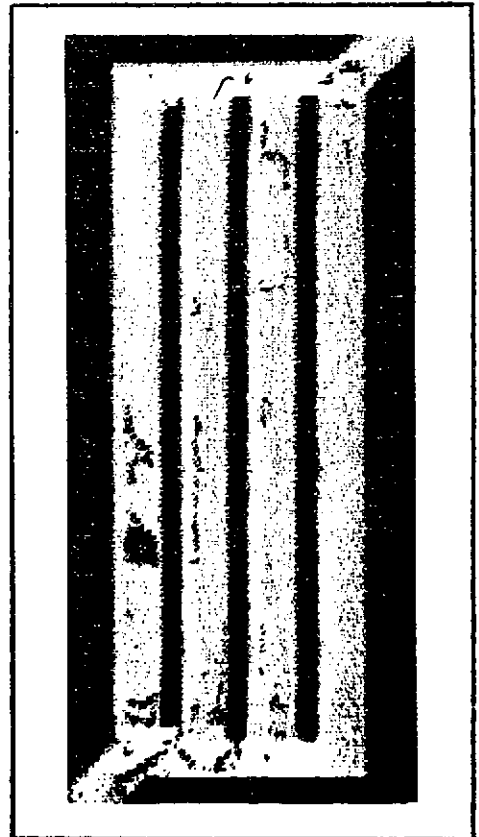
Press. $13.8 \times 10^5 N/M^2$
(200 PSI)

A E
FLAW LOCATOR
CENTER LAND

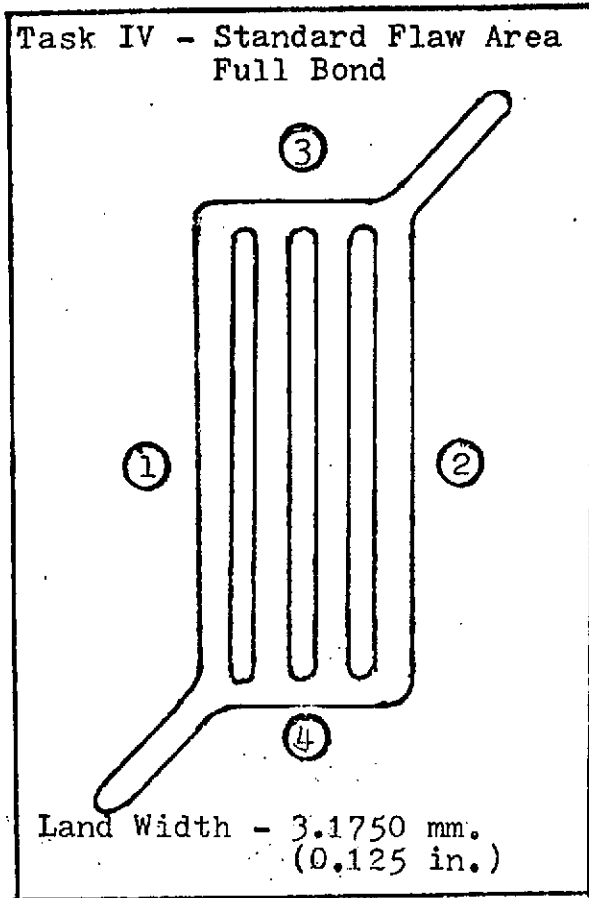


171

UT



BRAZED PANEL NO. B-04



BASEPLATE

MATERIAL: OFHC Copper

THICKNESS:	MM.	INCHES
①	6.4313	0.2532
②	6.4287	0.2531
③	6.4770	0.2550
④	6.3805	0.2512

COVERPLATE

MATERIAL: 304L Stainless Steel

THICKNESS:	MM.	INCHES
①	1.2217	0.0481
②	1.2217	0.0481
③	1.2217	0.0481
④	1.2243	0.0482

PRESSURE REQUIRED TO FAIL BOND:

Bond failed at a pressure of $3.73 \times 10^7 \text{ N/m}^2$ (5,400 psi).

CENTER LAND DEFECT

METALLOGRAPHIC ANALYSIS:

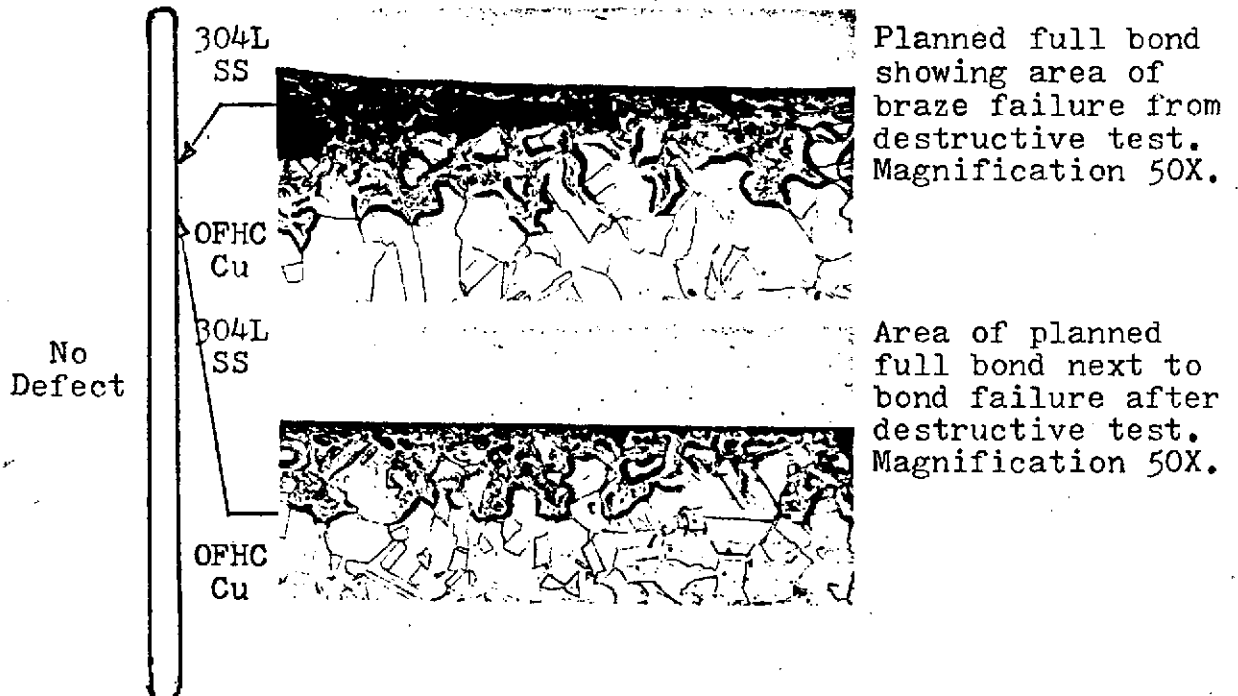
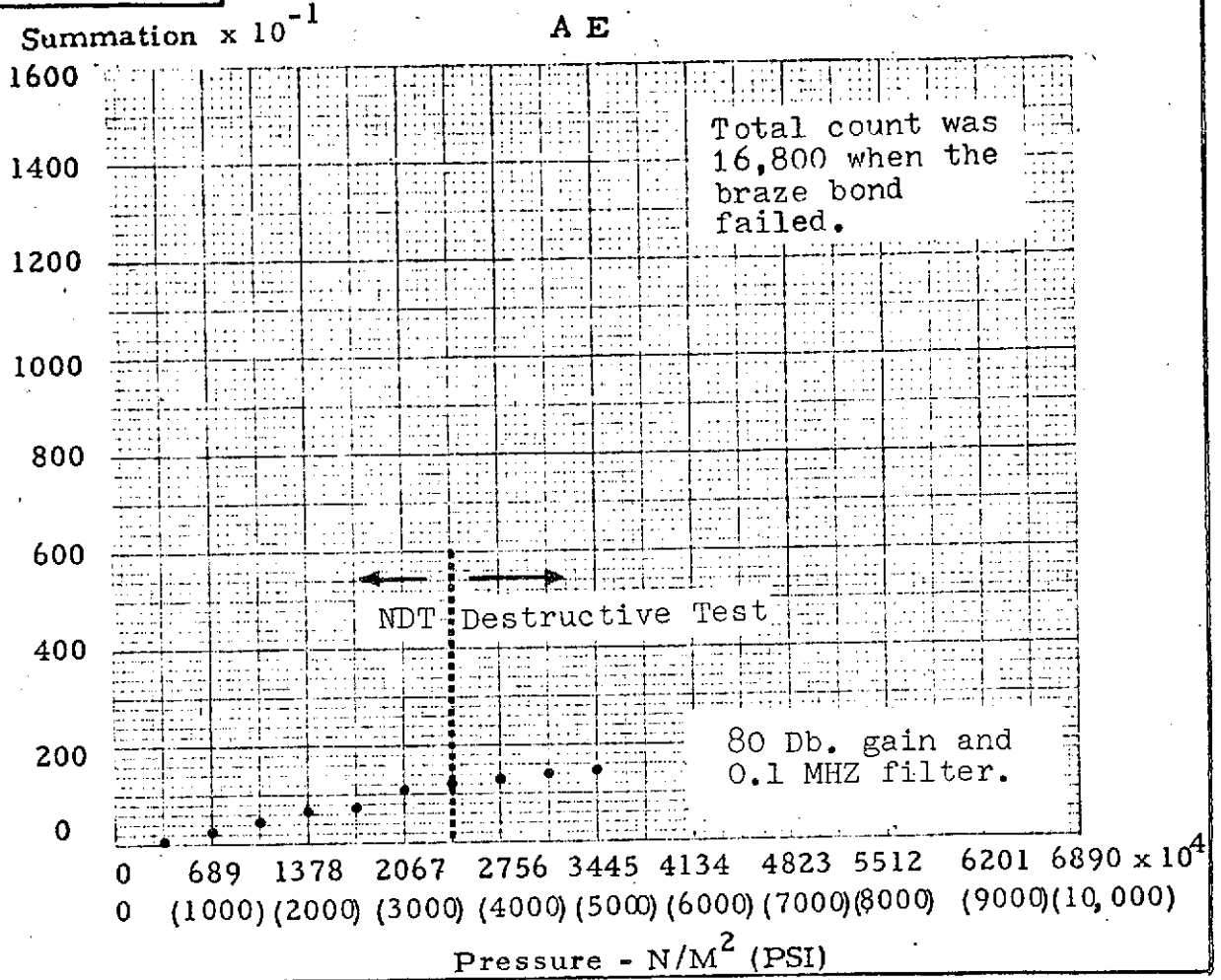
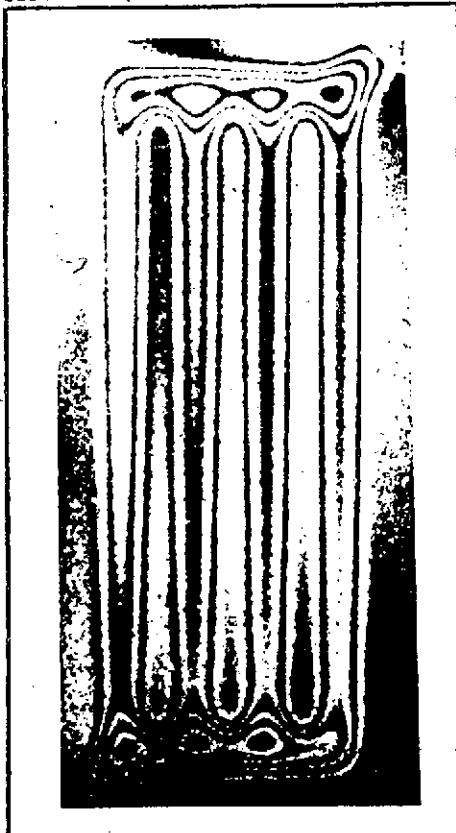


FIGURE C-52

Panel No. B-4



HNDT (Before AE)

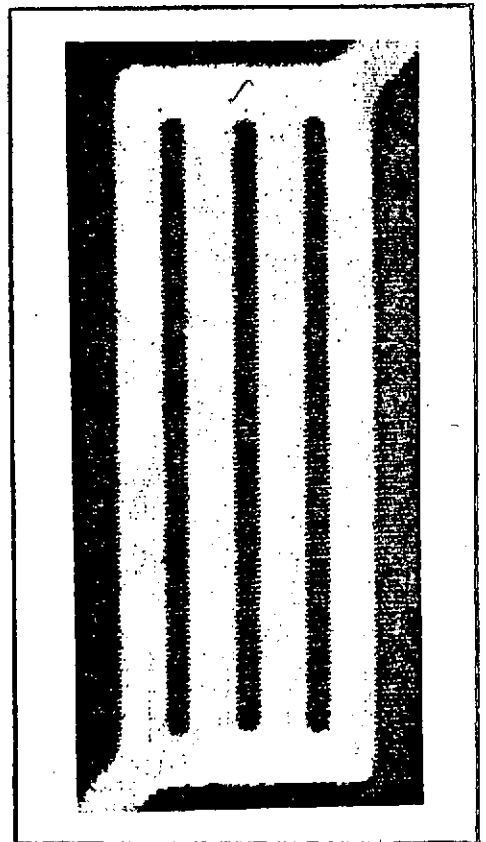


Press. - $13.8 \times 10^5 N/M^2$
(200 PSI)

AE
FLAW LOCATOR
CENTER LAND

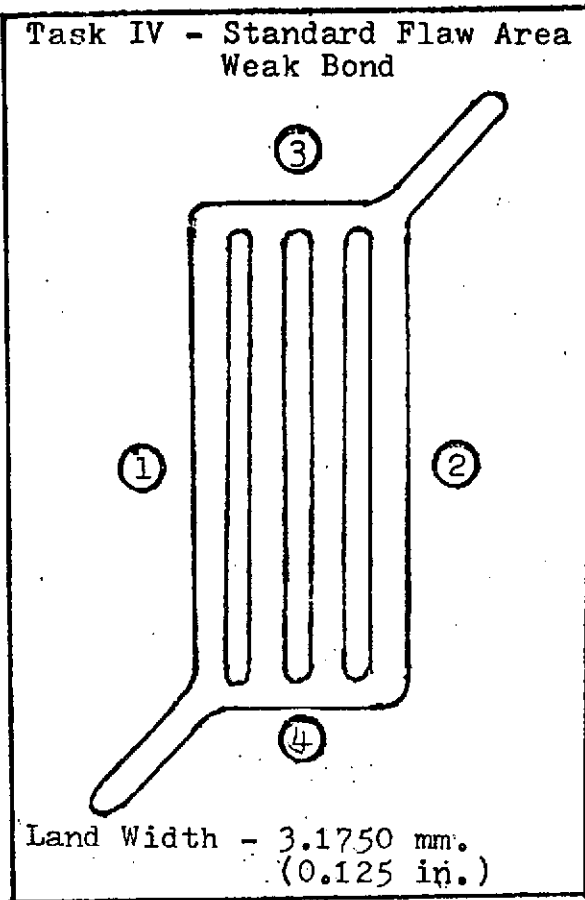


UT



173

BRAZED PANEL NO. B-18



BASEPLATE

MATERIAL: OFHC Copper

THICKNESS:	MM.	INCHES
①	6.6827	0.2631
②	6.6091	0.2602
③	6.6599	0.2622
④	6.7234	0.2647

COVERPLATE

MATERIAL: 304L Stainless Steel

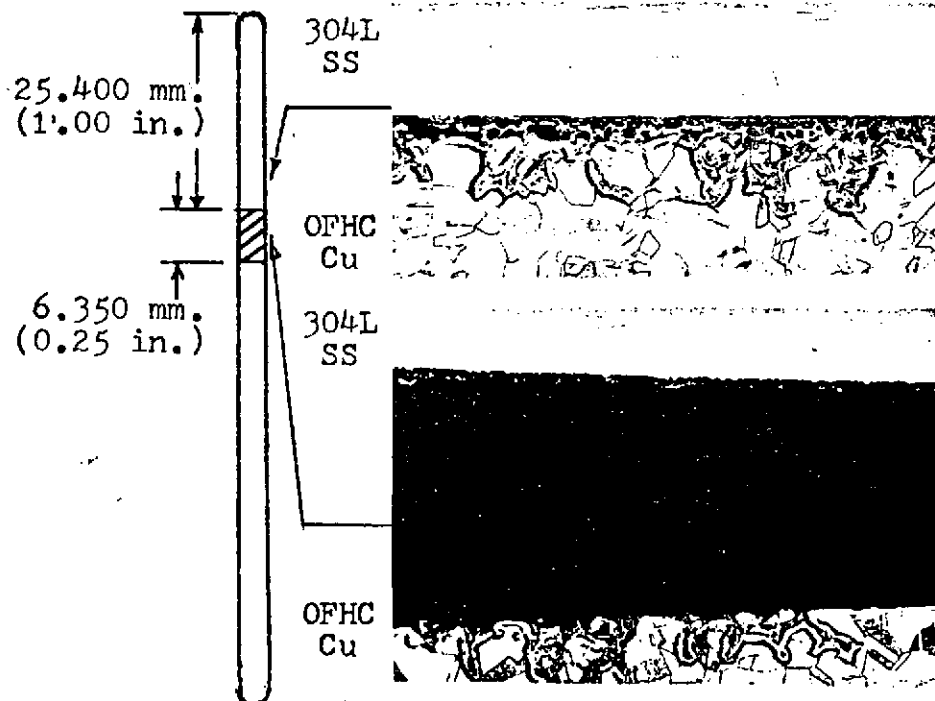
THICKNESS:	MM.	INCHES
①	1.2217	0.0481
②	1.2243	0.0482
③	1.2243	0.0482
④	1.2243	0.0482

PRESSURE REQUIRED TO FAIL BOND:

Braze failed at a pressure of $2.90 \times 10^7 \text{ N/m}^2$ (4,200 psi).

CENTER LAND DEFECT

METALLOGRAPHIC ANALYSIS:

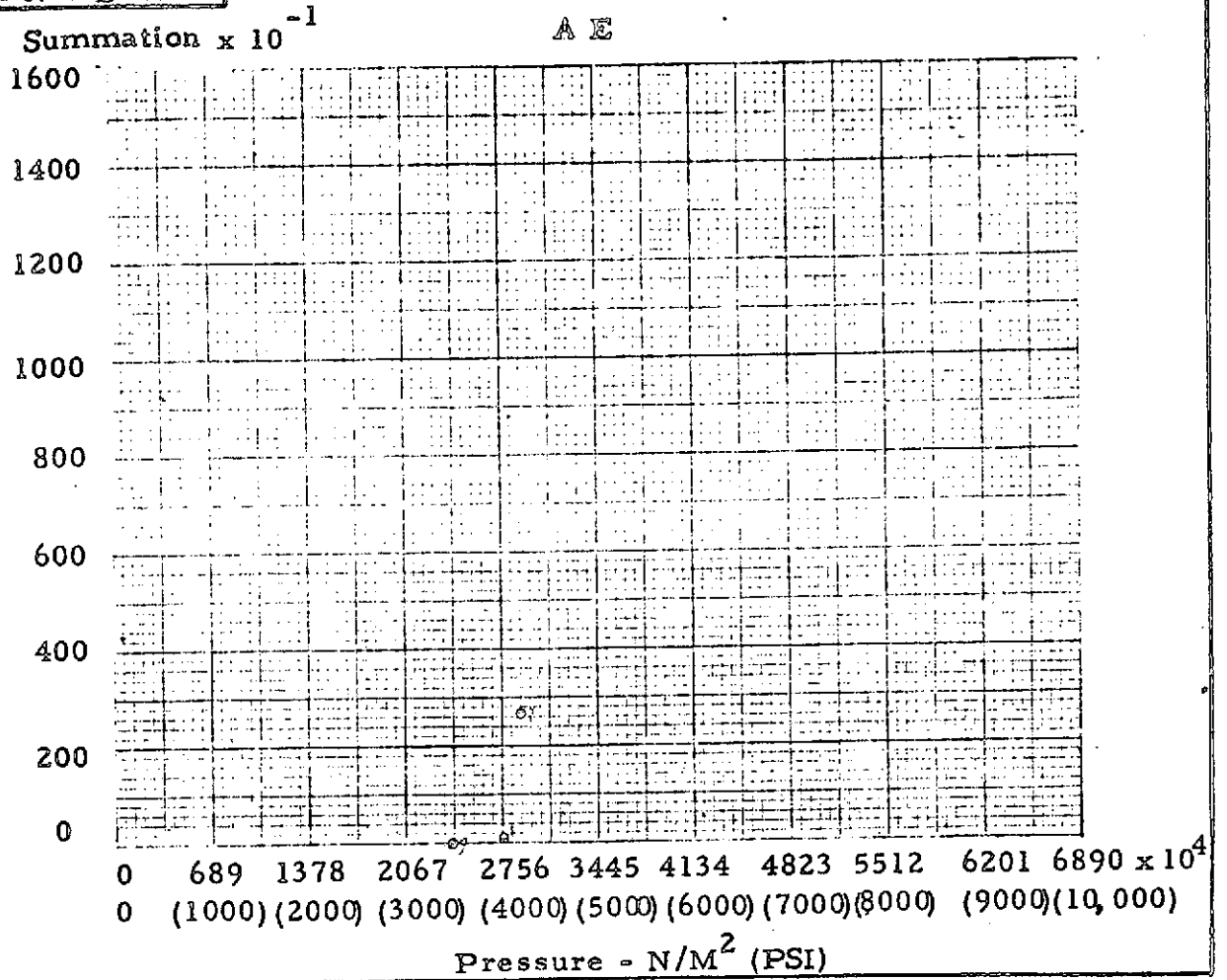


Full braze bond near the planned weak bond. Voids in braze indicate some metal failure in destructive test. Magnification 50X.

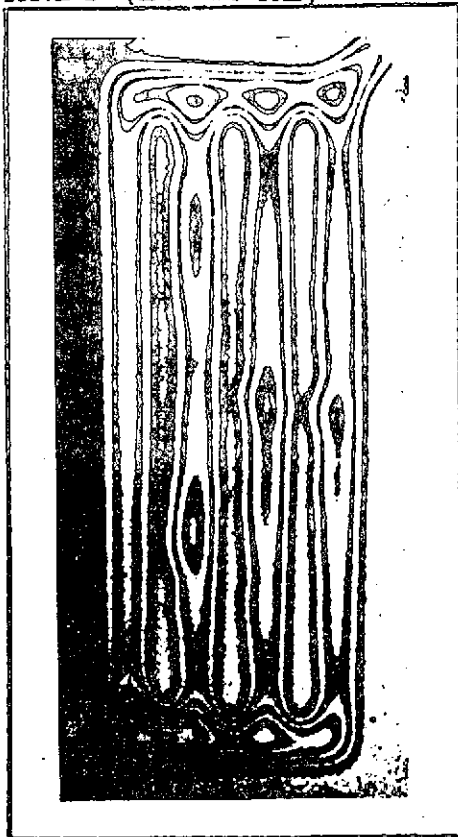
Complete bondline separation occurred in the planned weak bond. Braze layer appears to be "starved". Magnification 50X.

FIGURE C-53

Panel No. B-18



HNDT (Before AE)



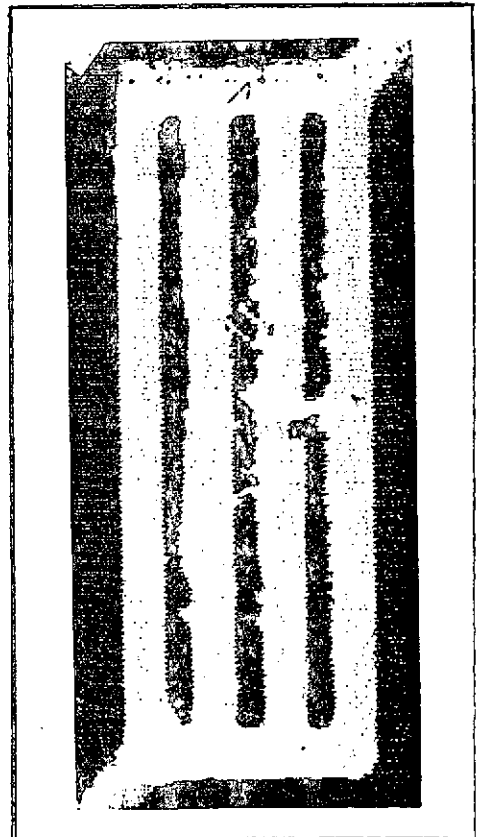
Press. $13.8 \times 10^5 N/M^2$
(200 PSI)

AE
FLAW LOCATOR
CENTER LAND

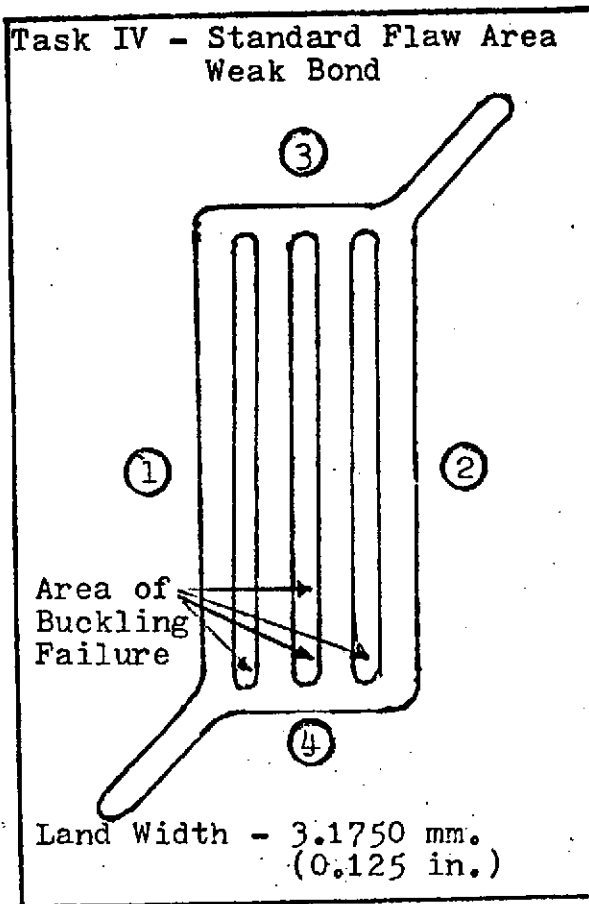


175

UT



BRAZED PANEL NO. B-16



BASEPLATE

MATERIAL: OFHC Copper

THICKNESS:	MM.	INCHES
①	6.6904	0.2634
②	6.7031	0.2639
③	6.7005	0.2638
④	6.6827	0.2631

COVERPLATE

MATERIAL: 304L Stainless Steel

THICKNESS:	MM.	INCHES
①	1.2243	0.0482
②	1.2243	0.0482
③	1.2243	0.0482
④	1.2217	0.0481

PRESSURE REQUIRED TO FAIL BOND:

Braze failed at a pressure of $2.83 \times 10^7 \text{ N/m}^2$ (4,100 psi).

CENTER LAND DEFECT

METALLOGRAPHIC ANALYSIS:

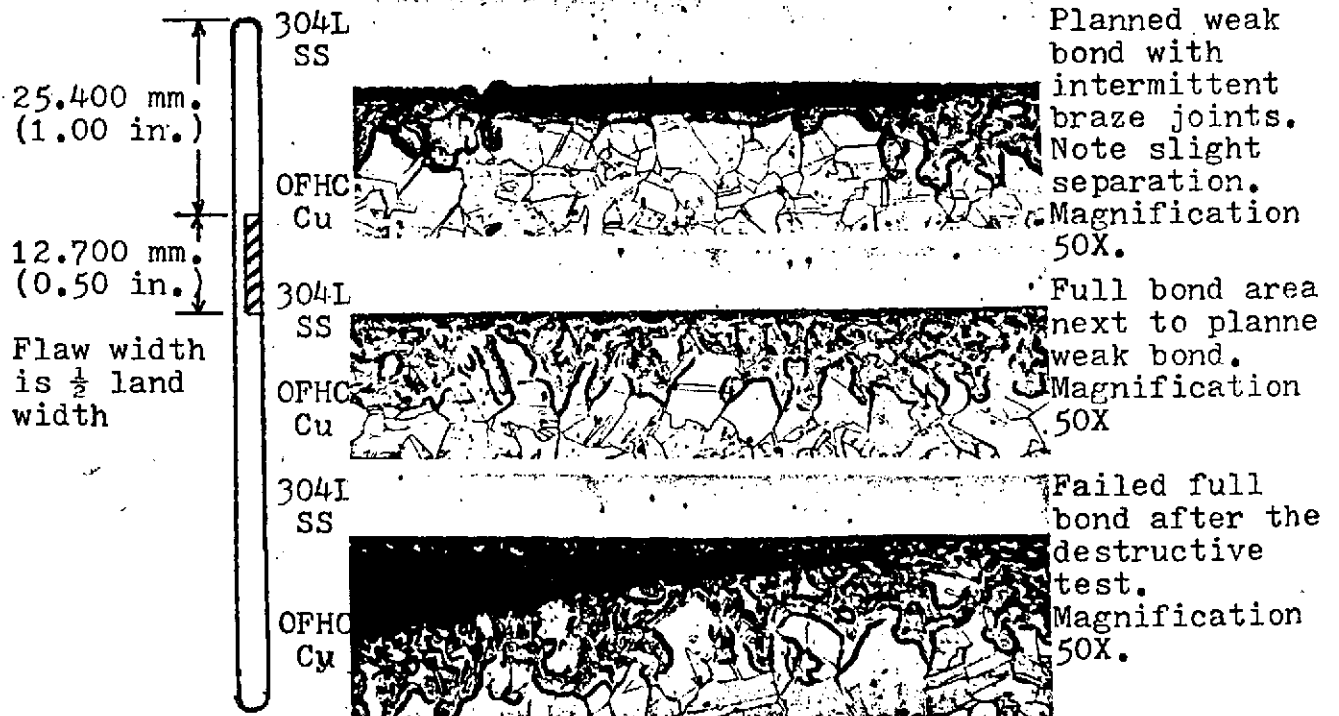
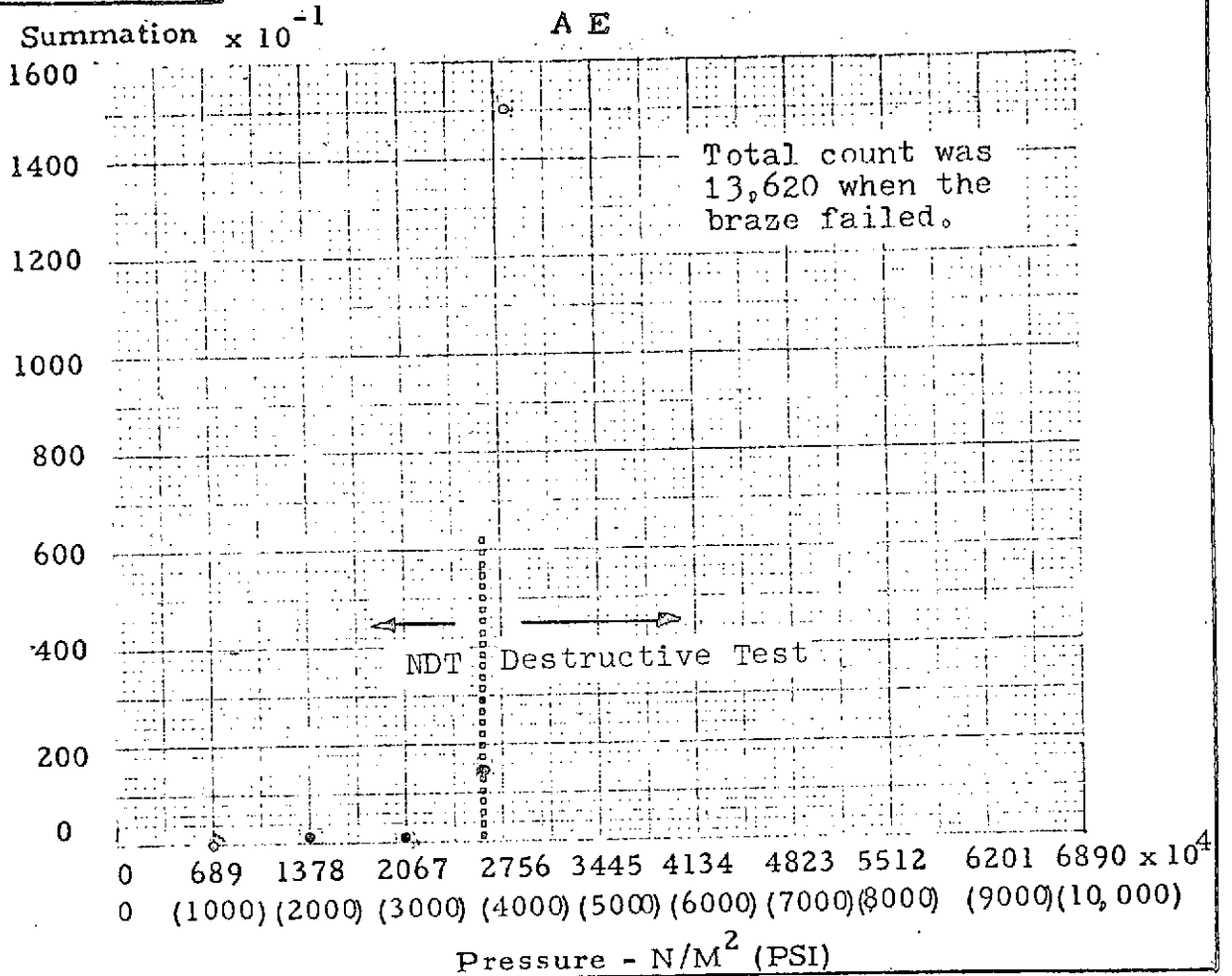
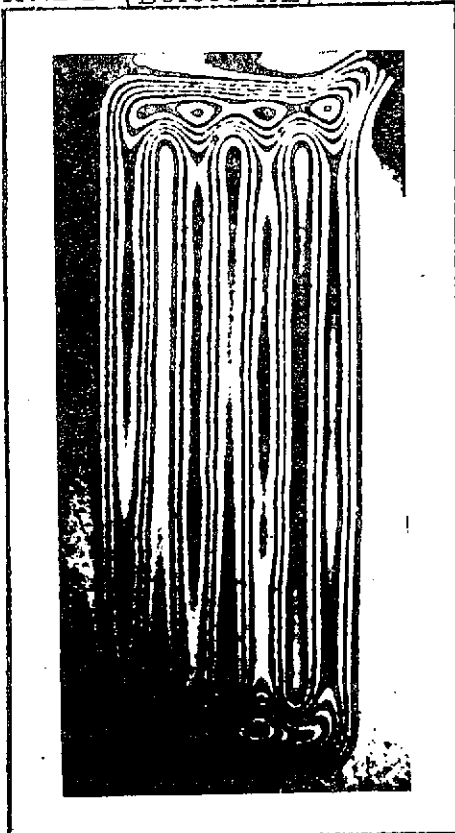


FIGURE C-54

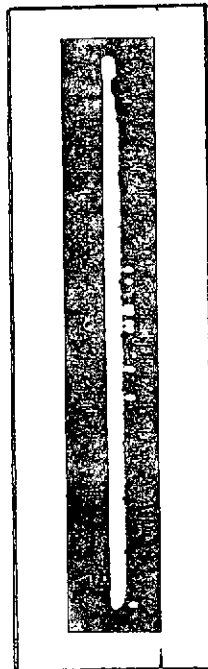
Panel No. B-16



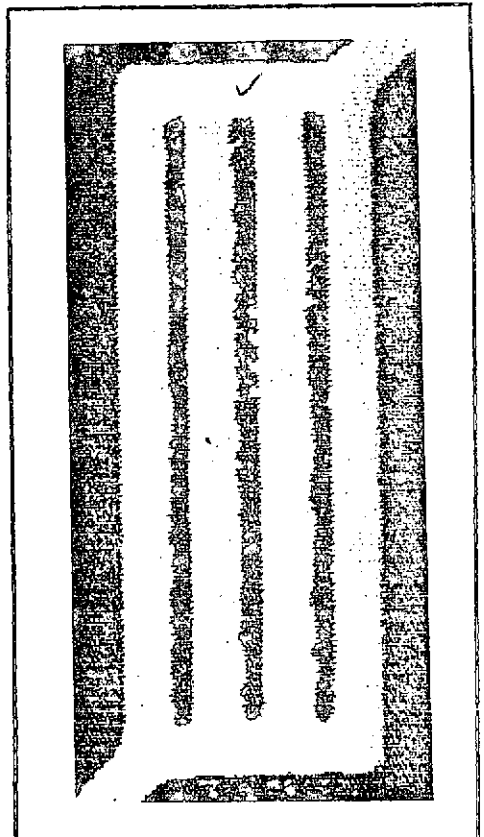
HNDT (Before AE)



AE
FLAW LOCATOR
CENTER LAND

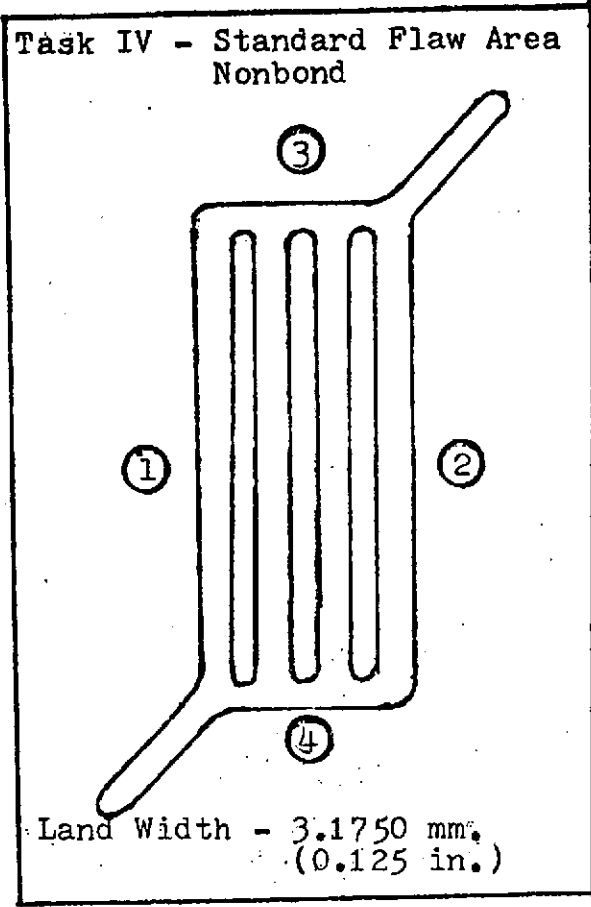


UT



Press. $20.7 \times 10^5 N/M^2$
(300 PSI)

BRAZED PANEL NO. B-08



BASEPLATE

MATERIAL: OFHC Copper

THICKNESS:	MM.	INCHES
①	6.6675	0.2625
②	6.6700	0.2626
③	6.6599	0.2622
④	6.6396	0.2614

COVERPLATE

MATERIAL: 304L Stainless Steel

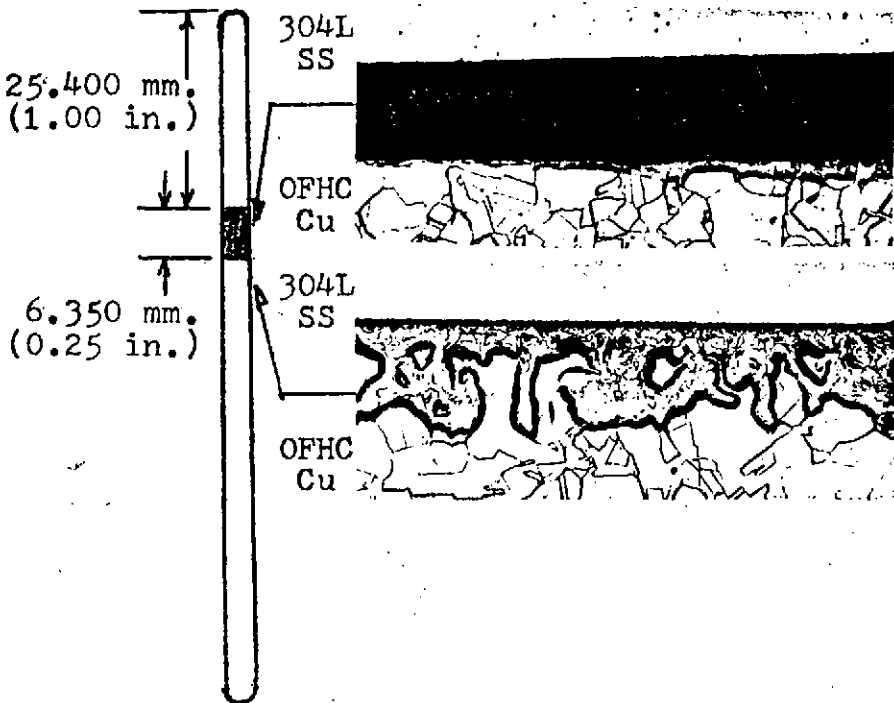
THICKNESS:	MM.	INCHES
①	1.2268	0.0483
②	1.2268	0.0483
③	1.2268	0.0483
④	1.2243	0.0482

PRESSURE REQUIRED TO FAIL BOND:

Panel showed visible failure at a pressure of 3.45×10^7 N/m² (5,000 psi). Nonbond separation may have occurred at a lower value.

CENTER LAND DEFECT

METALLOGRAPHIC ANALYSIS:

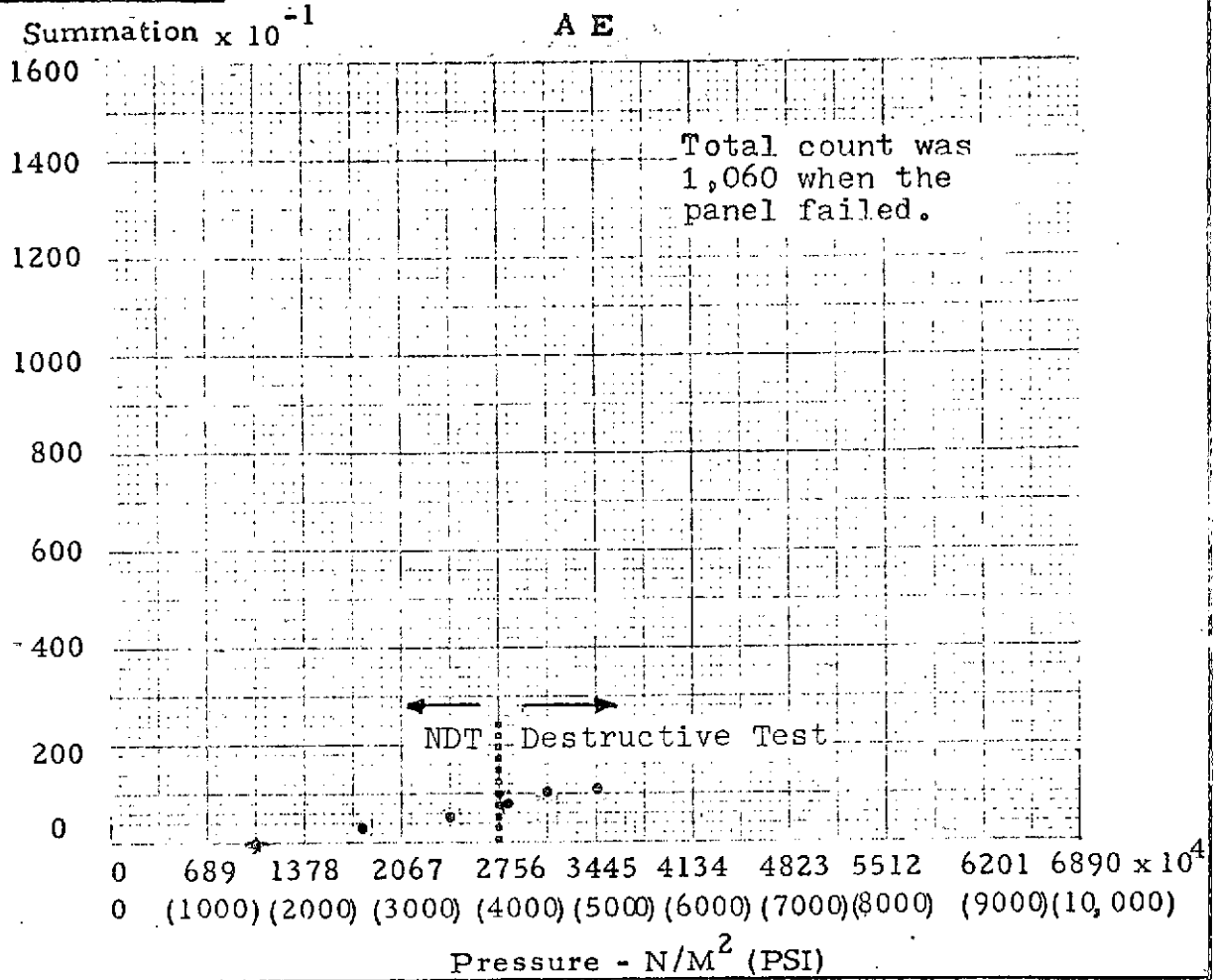


Planned nonbond area showing some braze wetting of the OFHC Copper but no wetting of the 304L SS. Magnification 50X.

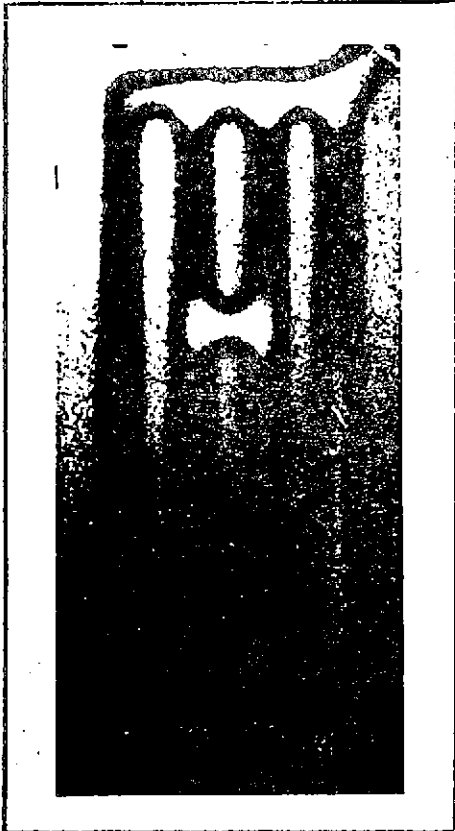
Section of the full bond next to the planned nonbond. No failure occurred. Magnification 50X.

FIGURE C-55

Panel No. B-8

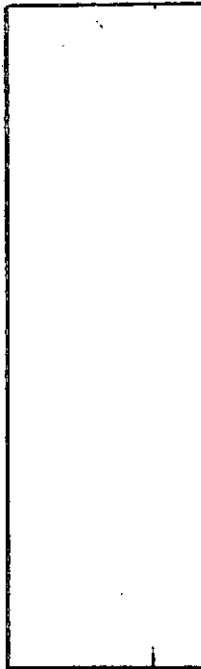


HNDT (Before AE)

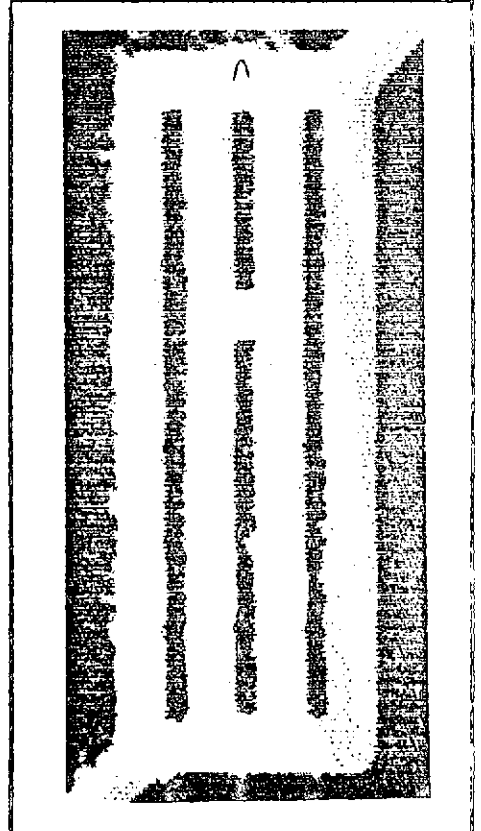


Press. $34.5 \times 10^5 N/M^2$
(500 PSI)

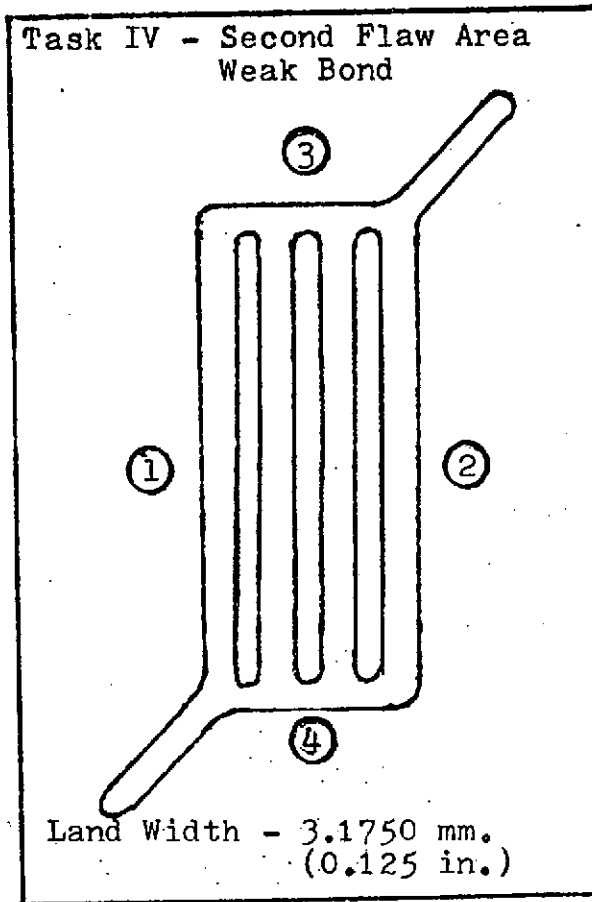
AE
FLAW LOCATOR
CENTER LAND



UT



BRAZED PANEL NO. B-20



BASEPLATE

MATERIAL: OFHC Copper

THICKNESS:	MM.	INCHES
①	6.3551	0.2502
②	6.4059	0.2522
③	6.4414	0.2536
④	6.3525	0.2501

COVERPLATE

MATERIAL: 304L Stainless Steel

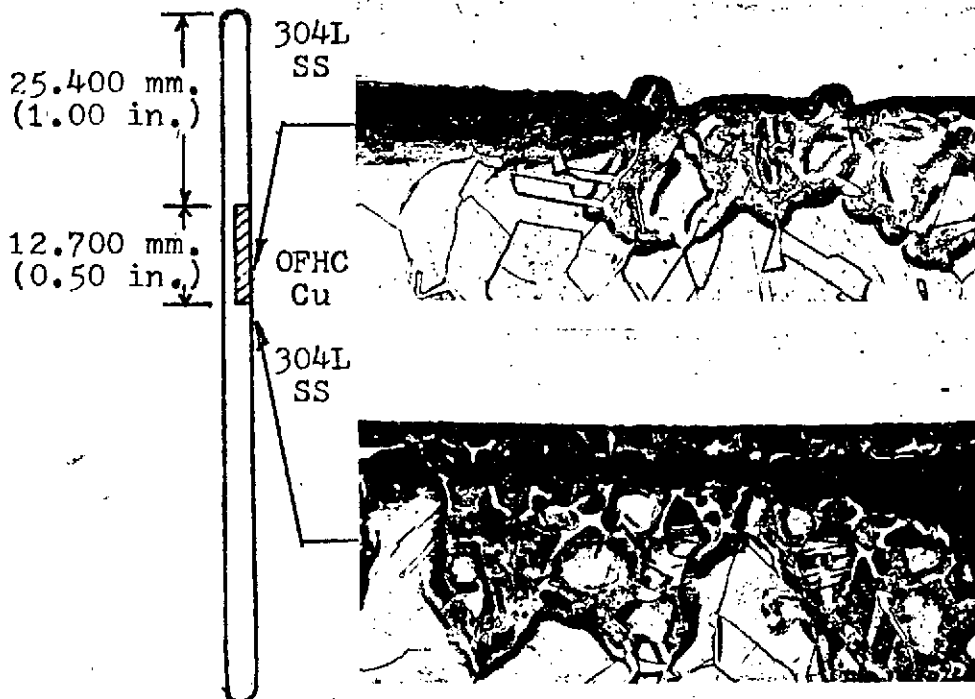
THICKNESS:	MM.	INCHES
①	1.2217	0.0481
②	1.2217	0.0481
③	1.2243	0.0482
④	1.2217	0.0481

PRESSURE REQUIRED TO FAIL BOND:

Braze failed at a pressure of $3.24 \times 10^7 \text{ N/m}^2$ (4,700 psi).

CENTER LAND DEFECT

METALLOGRAPHIC ANALYSIS:



Section from planned weak bond showing end of defect. Slight separation occurred. Magnification 50X.

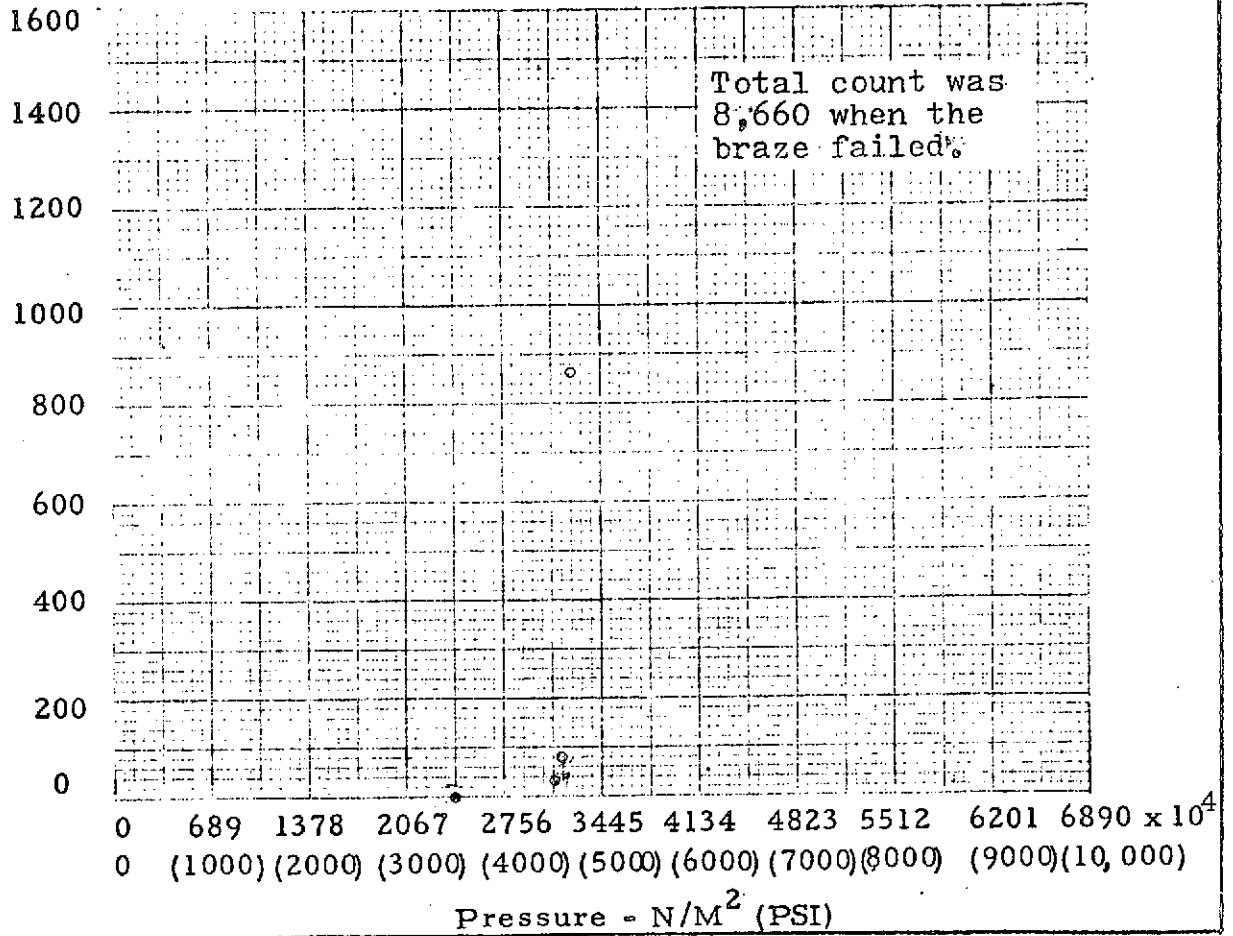
Full braze bond area next to the planned weak bond. In destructive test, failure occurred. Magnification 50X.

FIGURE C-56

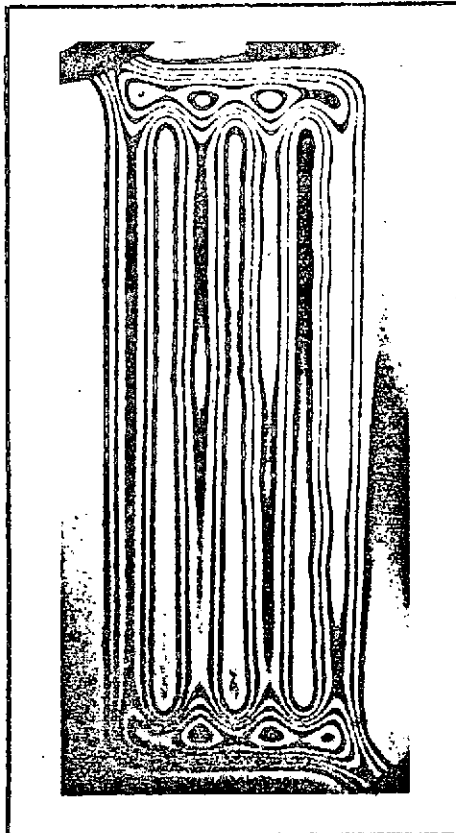
Panel No. B-20

Summation $\times 10^{-1}$

A E

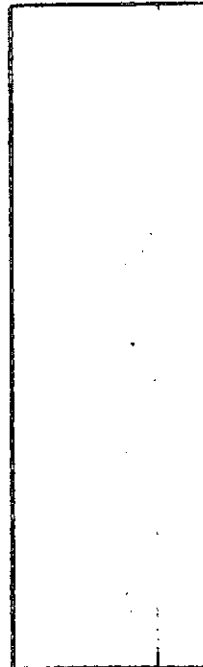


HNDT (Before AE)

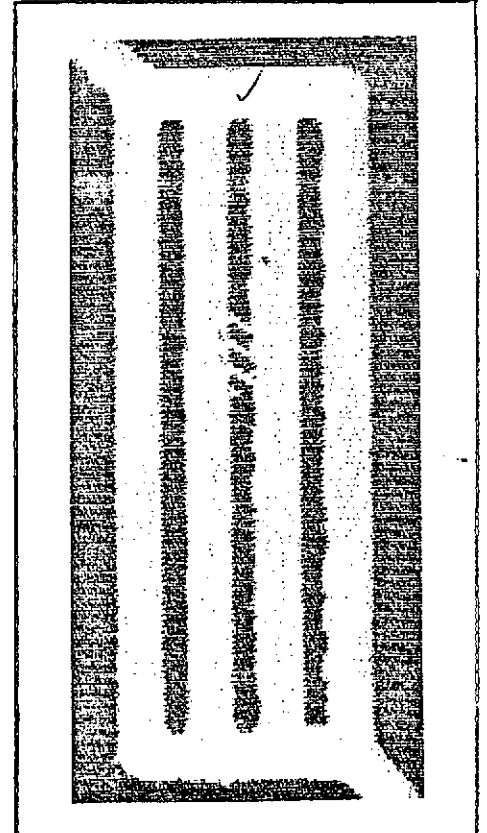


Press. $20.7 \times 10^5 N/M^2$
(300 PSI)

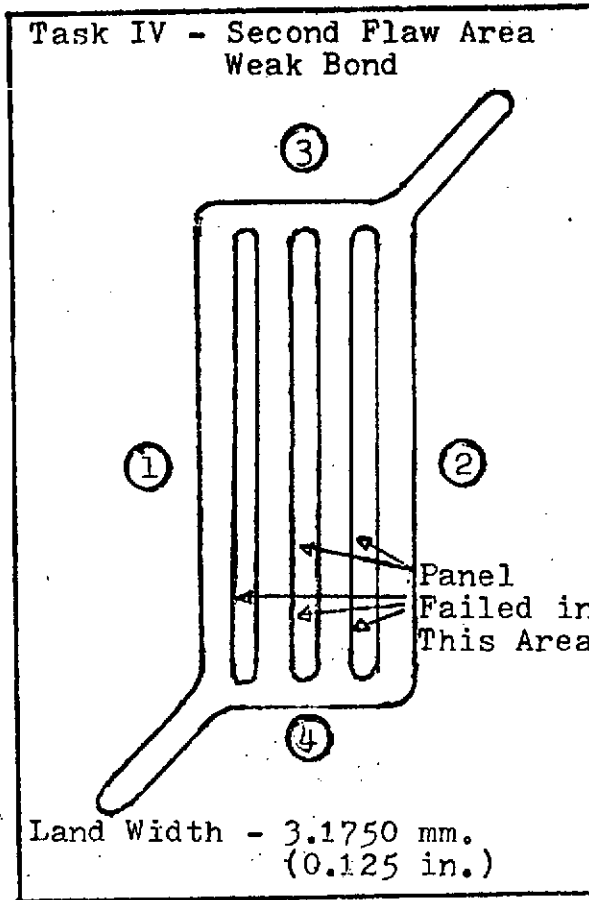
AE
FLAW LOCATOR
CENTER LAND



UT



BRAZED PANEL NO. B-17



BASEPLATE

MATERIAL: OFHC Copper

THICKNESS:	MM.	INCHES
①	6.6624	0.2623
②	6.6523	0.2619
③	6.6777	0.2629
④	6.6015	0.2599

COVERPLATE

MATERIAL: 304L Stainless Steel

THICKNESS:	MM.	INCHES
①	1.2243	0.0482
②	1.2243	0.0482
③	1.2268	0.0483
④	1.2243	0.0482

PRESSURE REQUIRED TO FAIL BOND:

Braze failed at a pressure of $2.83 \times 10^7 \text{ N/m}^2$ (4,100 psi).

CENTER LAND DEFECT

METALLOGRAPHIC ANALYSIS:

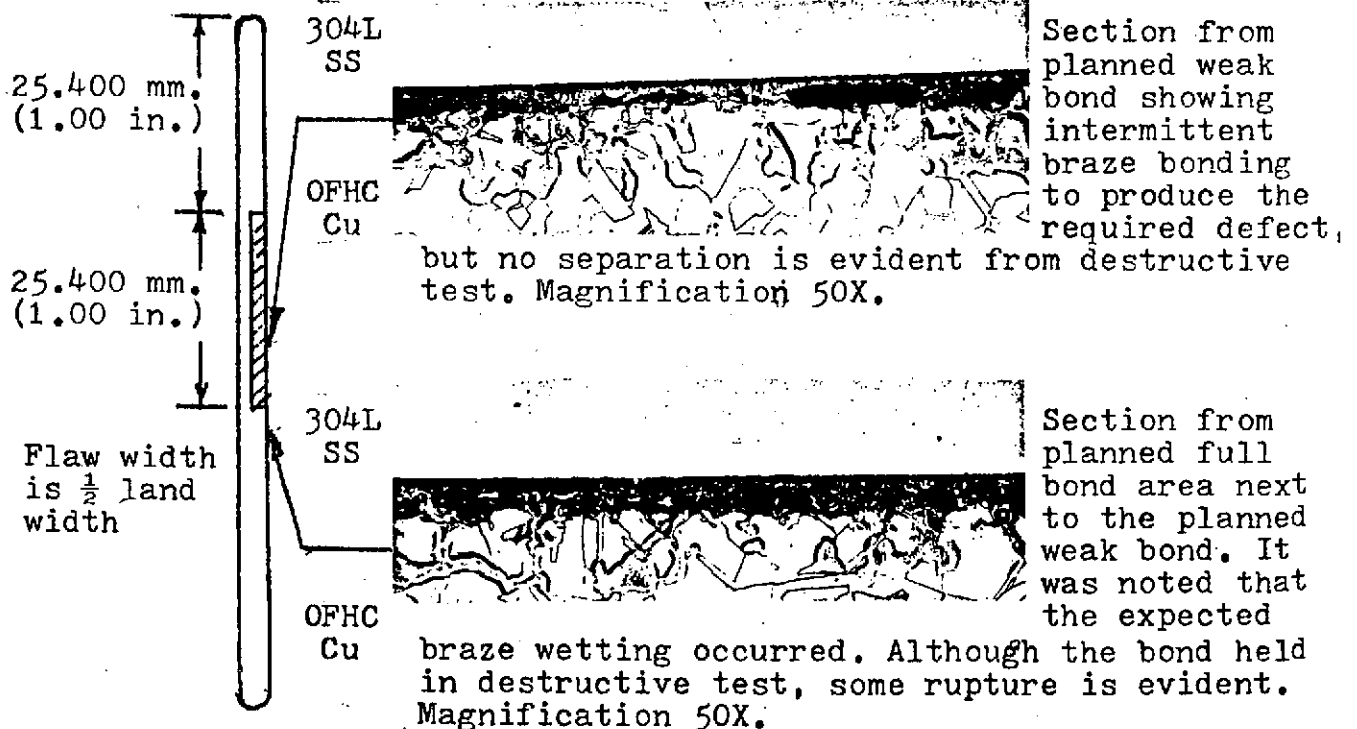
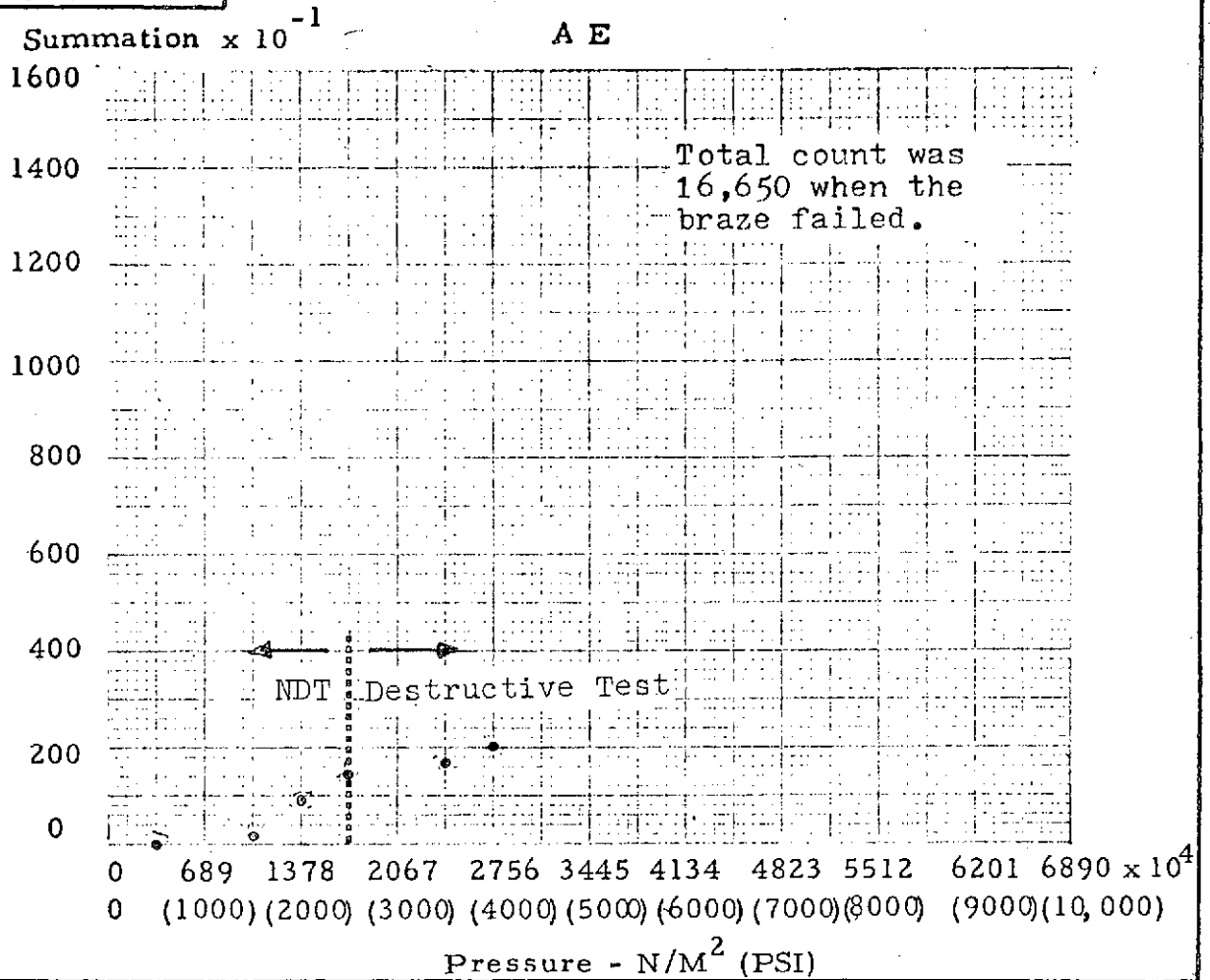
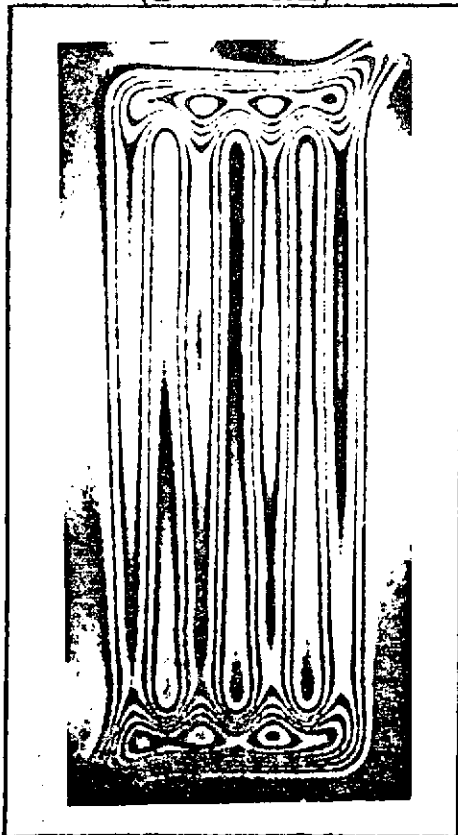


FIGURE C-57

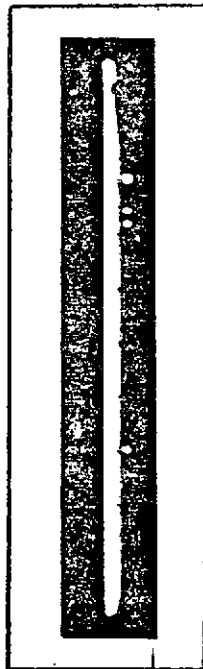


HNDT (Before AE)



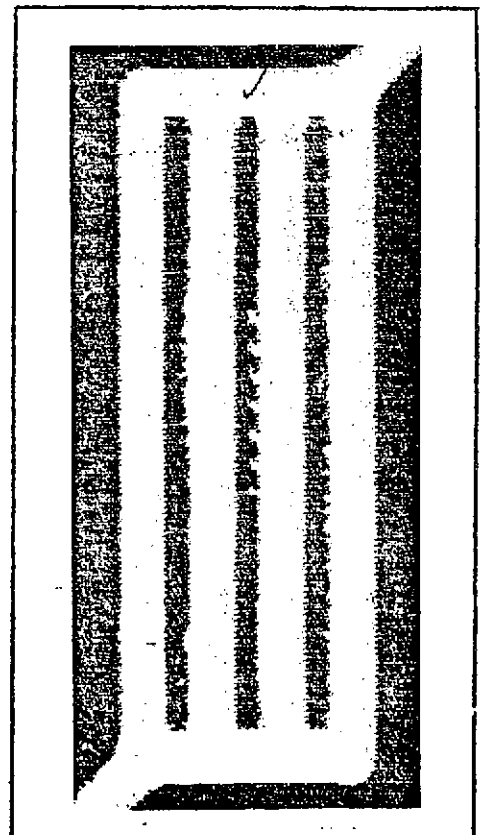
Press. 20.7×10^5 N/M²
(300 PSI)

AE
FLAW LOCATOR
CENTER LAND

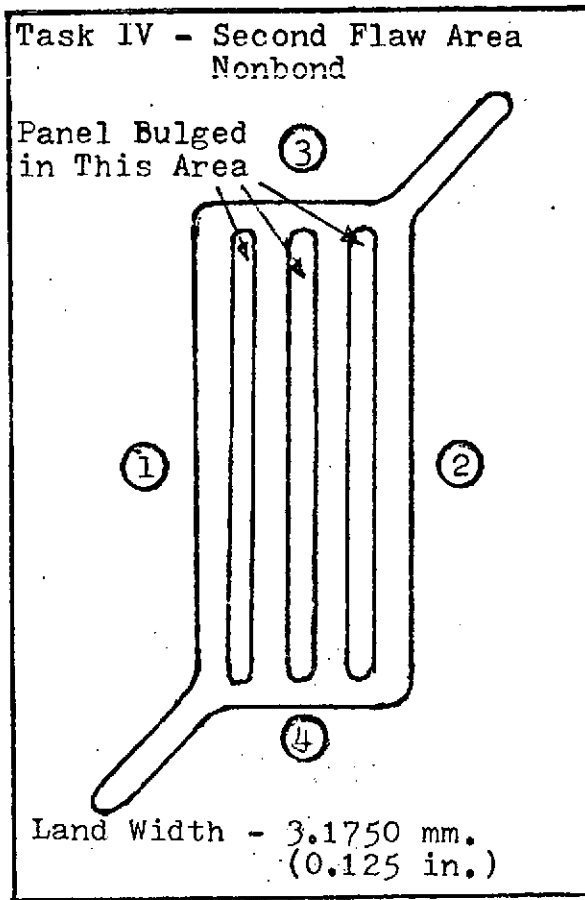


183

UT



BRAZED PANEL NO. B-09



BASEPLATE

MATERIAL: OFHC Copper

THICKNESS:	MM.	INCHES
①	6.6116	0.2603
②	6.5481	0.2578
③	6.5430	0.2576
④	6.6015	0.2599

COVERPLATE

MATERIAL: 304L Stainless Steel

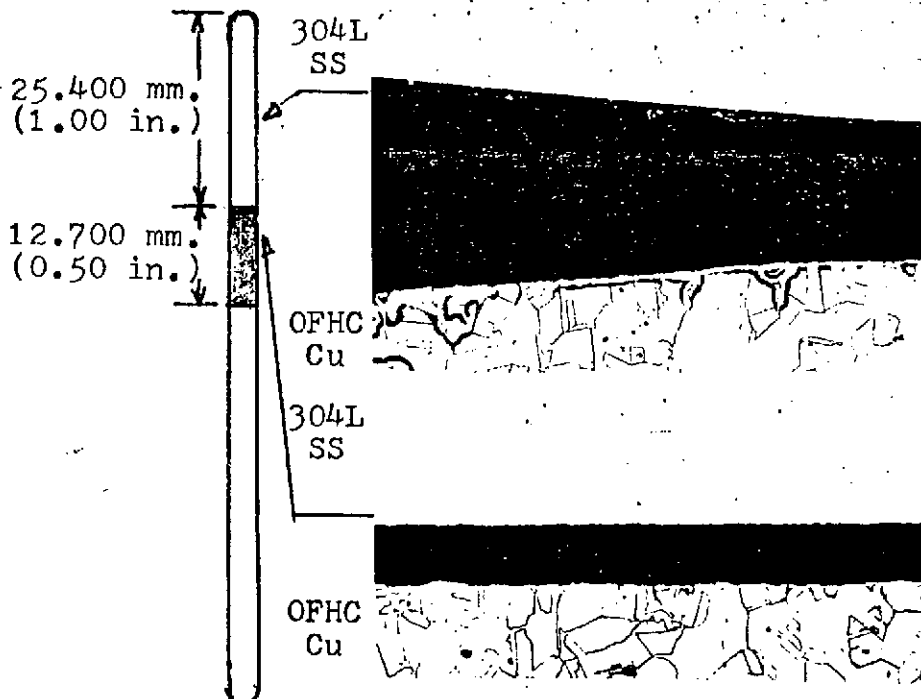
THICKNESS:	MM.	INCHES
①	1.2243	0.0482
②	1.2243	0.0482
③	1.2268	0.0483
④	1.2243	0.0482

PRESSURE REQUIRED TO FAIL BOND:

Defect separation was not visible until adjacent braze bond failed at 3.38×10^7 N/m² (4,900 psi).

CENTER LAND DEFECT

METALLOGRAPHIC ANALYSIS:



Full bond area showing failure through braze alloy. Braze layer appears thin. Magnification 50X.

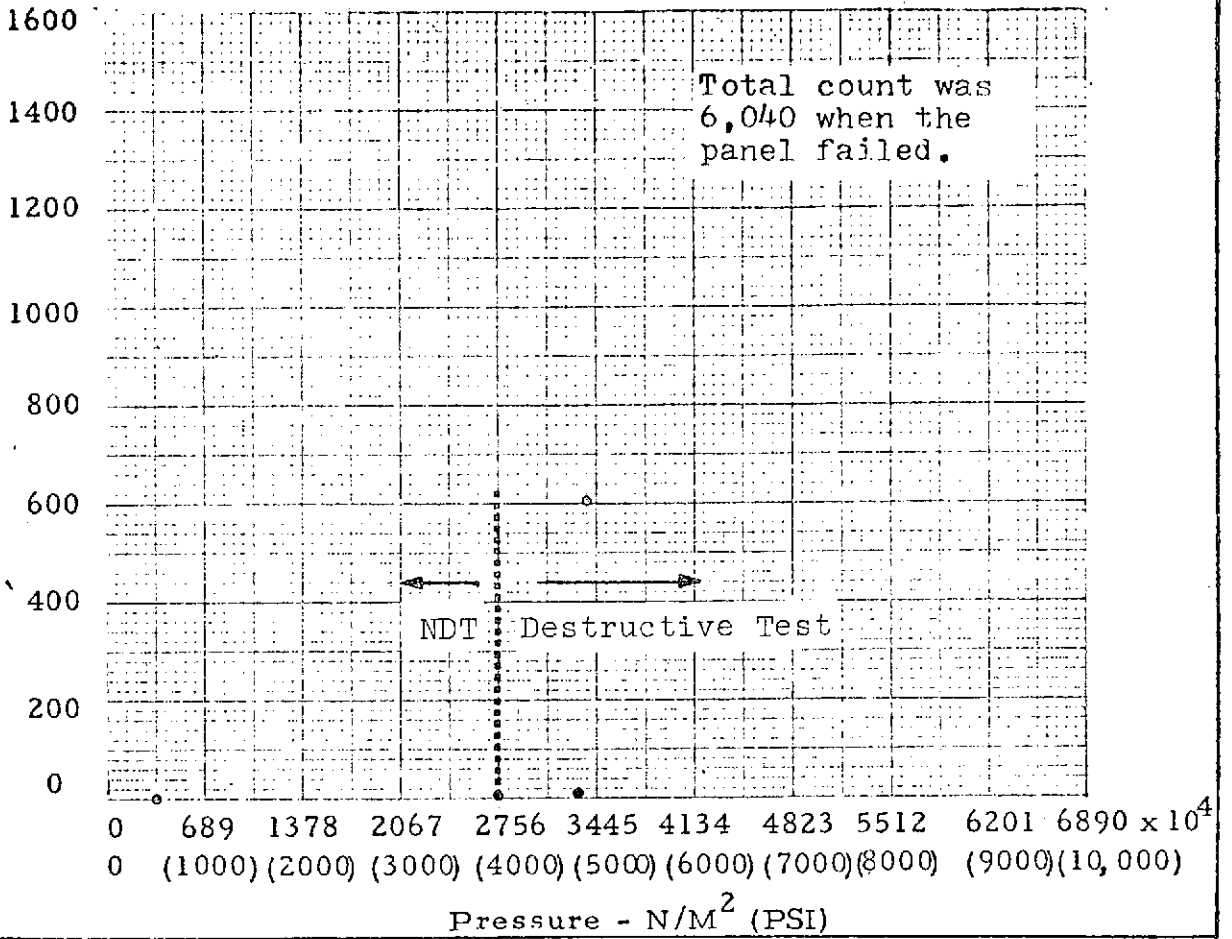
Section from the planned nonbond defect showing coverplate separation. Magnification 50X.

FIGURE C-58

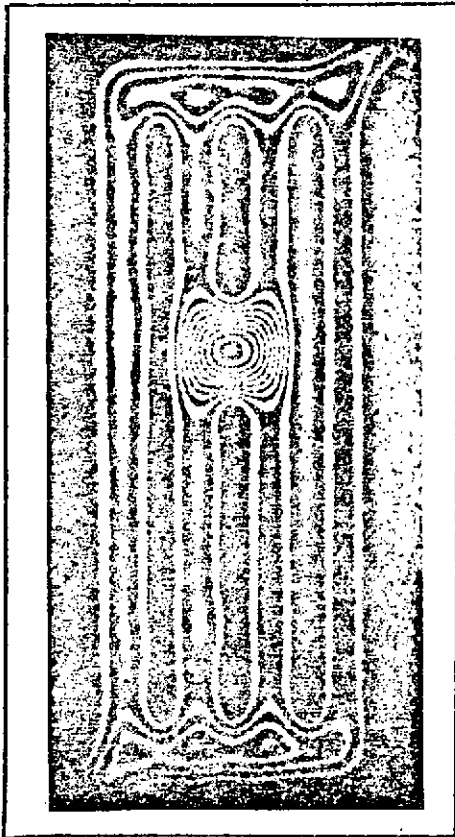
Panel No. B-9

Summation $\times 10^{-1}$

A E

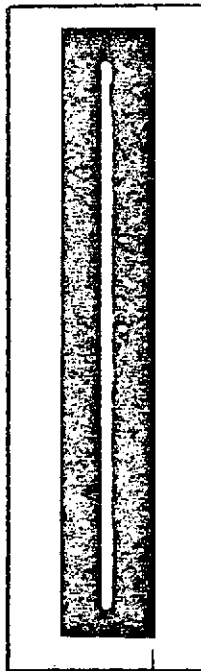


HNDT (Before AE)



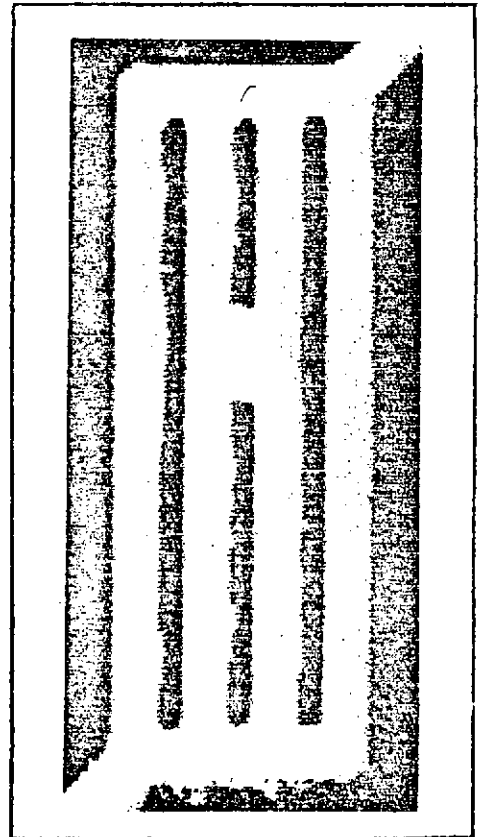
Press. - 10.35×10^5 N/M^2
(150 PSI)

AE
FLAW LOCATOR
CENTER LAND

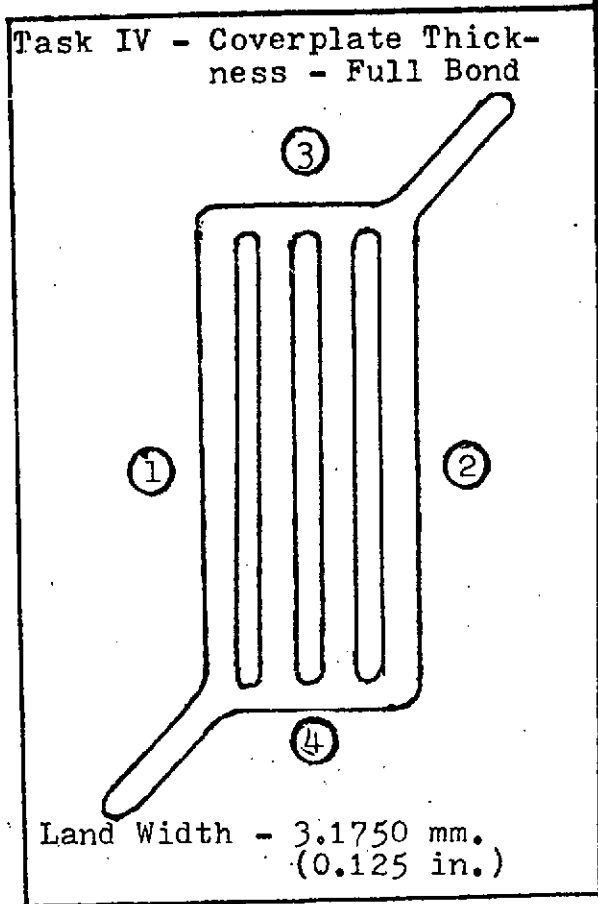


185

UT



BRAZED PANEL NO. B-06



BASEPLATE

MATERIAL: OFHC Copper

THICKNESS:	MM.	INCHES
①	6.5126	0.2564
②	6.4770	0.2550
③	6.5151	0.2565
④	6.4338	0.2533

COVERPLATE

MATERIAL: 347 Stainless Steel

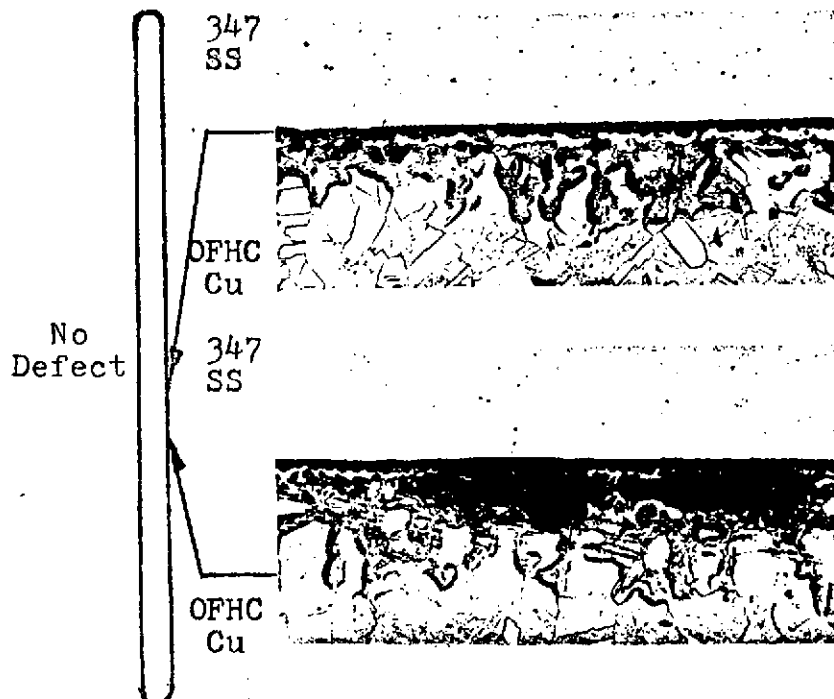
THICKNESS:	MM.	INCHES
①	2.3419	0.0922
②	2.3419	0.0922
③	2.3444	0.0923
④	2.3419	0.0922

PRESSURE REQUIRED TO FAIL BOND:

Panel failed at a pressure of 5.11×10^7 N/m² (7,400 psi).

CENTER LAND DEFECT

METALLOGRAPHIC ANALYSIS:

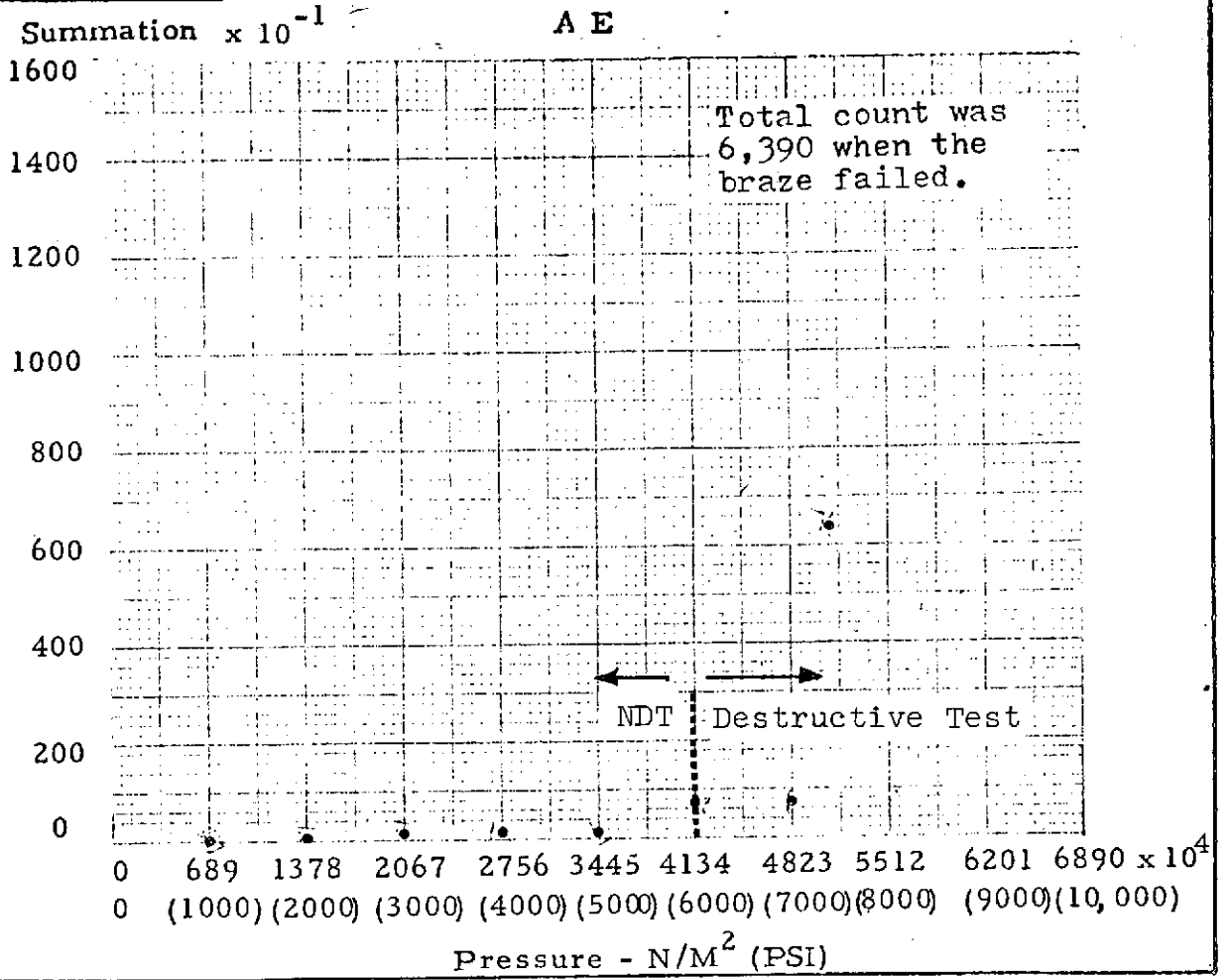


Section of planned full bond from an area of no failure. Magnification 50X.

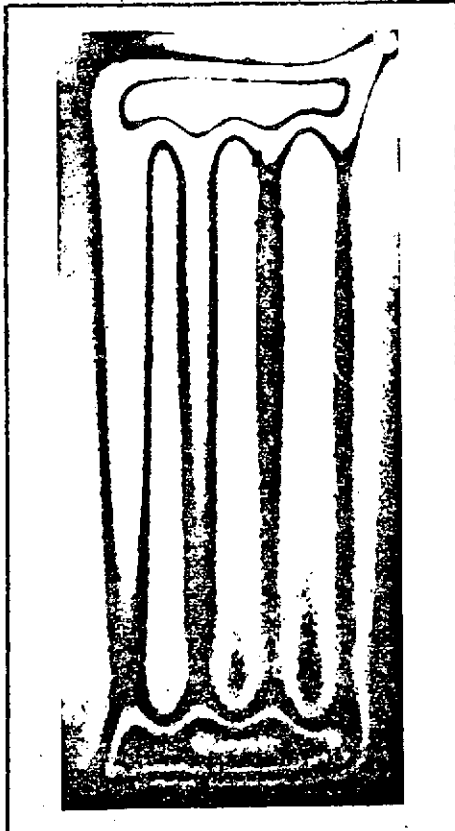
Area of planned full bond which exhibited failure after destructive test. Magnification 50X.

FIGURE C-59

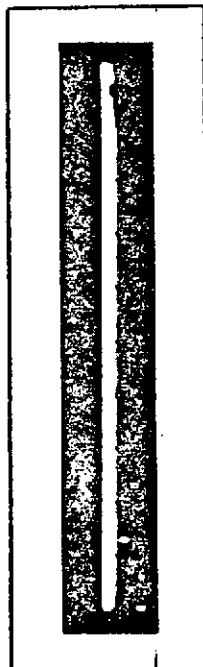
Panel No. B-6



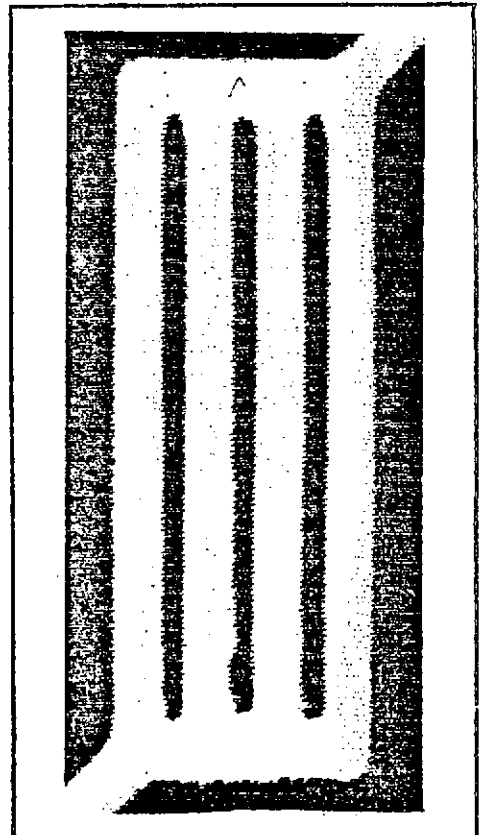
HNDT (Before AE)



AE
FLAW LOCATOR
CENTER LAND

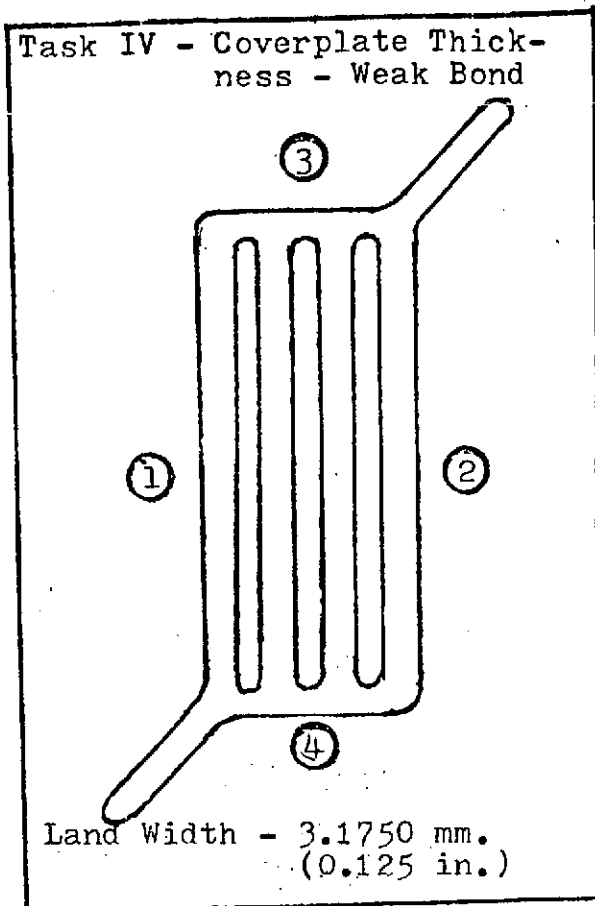


UT



Pres. 20.7×10^5 N/M^2
(300 PSI)

BRAZED PANEL NO. B-19



BASEPLATE

MATERIAL: OFHC Copper

THICKNESS:	MM.	INCHES
①	6.6091	0.2602
②	6.6422	0.2619
③	6.6192	0.2606
④	6.6167	0.2605

COVERPLATE

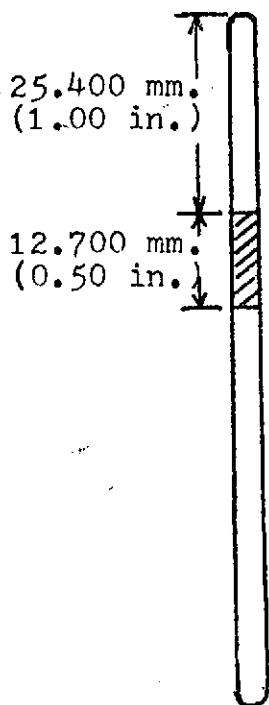
MATERIAL: 347 Stainless Steel

THICKNESS:	MM.	INCHES
①	2.3419	0.0922
②	2.3419	0.0922
③	2.3419	0.0922
④	2.3444	0.0923

PRESSURE REQUIRED TO FAIL BOND:

Not pressurized due to large unplanned nonbond area caused by coverplate warpage.

CENTER LAND DEFECT

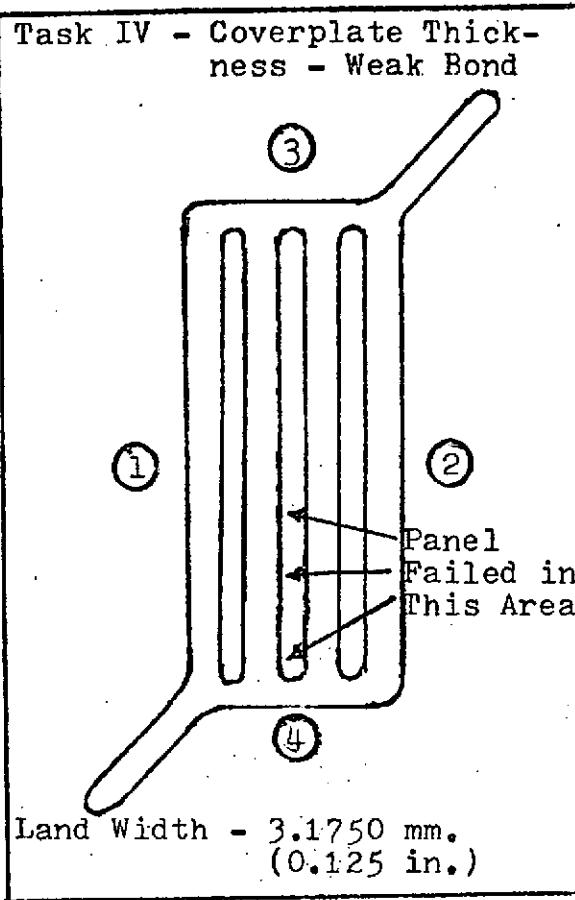


METALLOGRAPHIC ANALYSIS:

Not performed. Panel could not be pressurized due to leakage path.

FIGURE C-60

BRAZED PANEL NO. B-15



BASEPLATE

MATERIAL: OFHC Copper

THICKNESS:	MM.	INCHES
①	6.4364	0.2534
②	6.4389	0.2535
③	6.4237	0.2529
④	6.4287	0.2531

COVERPLATE

MATERIAL: 347 Stainless Steel

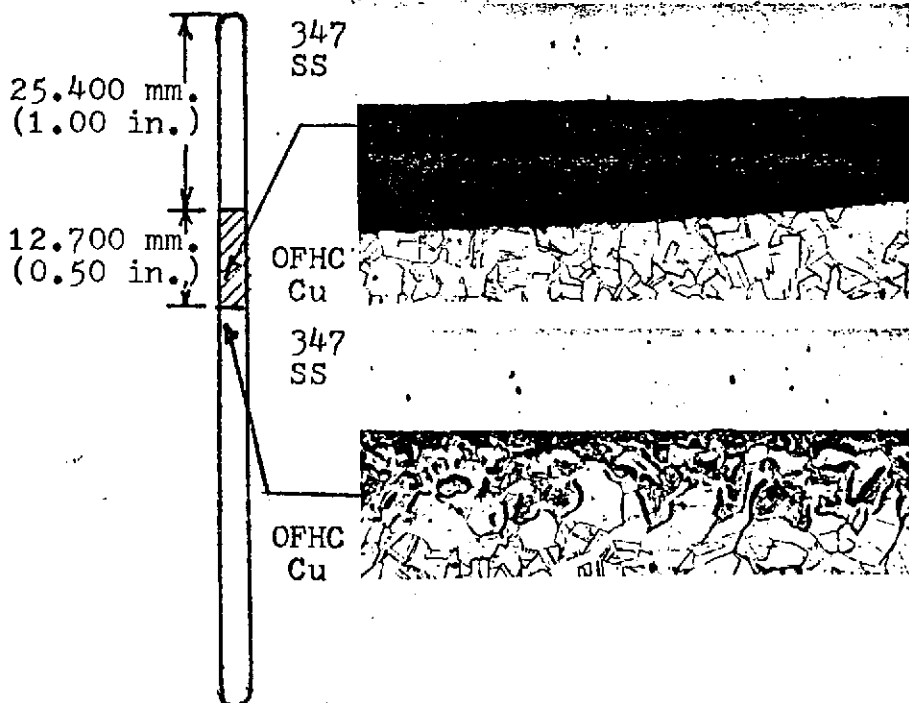
THICKNESS:	MM.	INCHES
①	2.3444	0.0923
②	2.3444	0.0923
③	2.3444	0.0923
④	2.3444	0.0923

PRESSURE REQUIRED TO FAIL BOND:

Braze failed at a pressure of $4.14 \times 10^7 \text{ N/m}^2$ (6,000 psi).

CENTER LAND DEFECT

METALLOGRAPHIC ANALYSIS:



Section of planned weakbond which was actually a nonbond due to deficiency of braze alloy in the "weak bond" area. Magnification 50X.

View of planned full bond located adjacent to the planned weak bond. No failure is noted. Magnification 50X.

FIGURE C-61

Panel No. B-15

Summation

A E

1600

1400

1200

1000

800

600

400

200

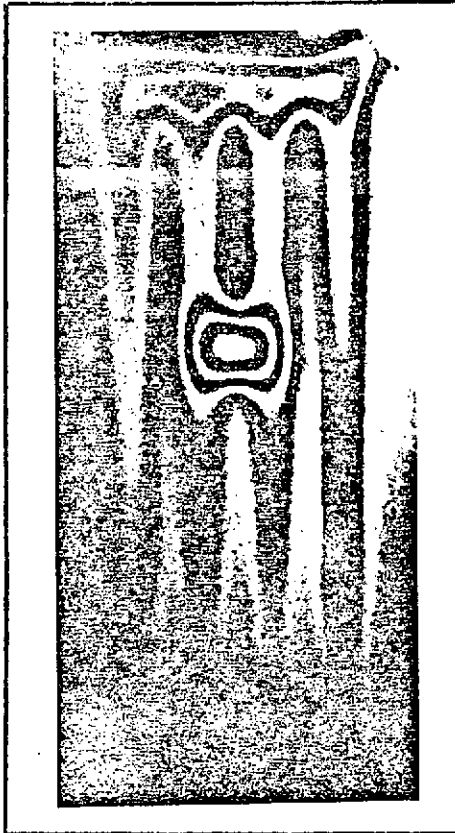
0

Total count was
2,460 when the
panel failed.

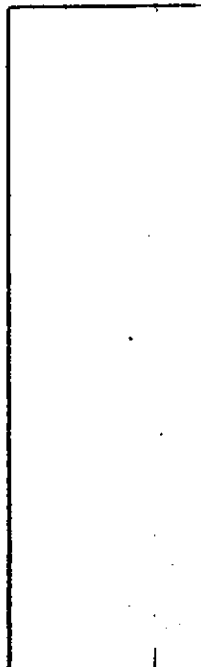
0 689 1378 2067 2756 3445 4134 4823 5512 6201 6890 x 10⁴
0 (1000) (2000) (3000) (4000) (5000) (6000) (7000) (8000) (9000) (10,000)

Pressure - N/M² (PSI)

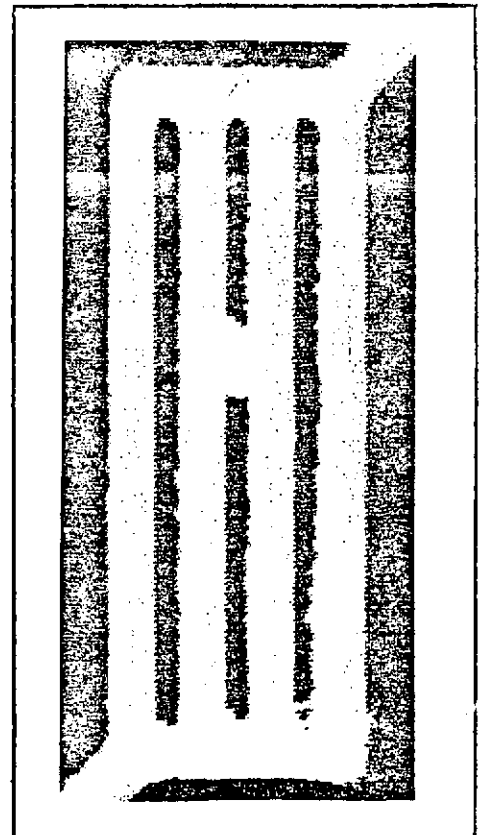
HNDT (Before AE)



AE
FLAW LOCATOR
CENTER LAND



UT

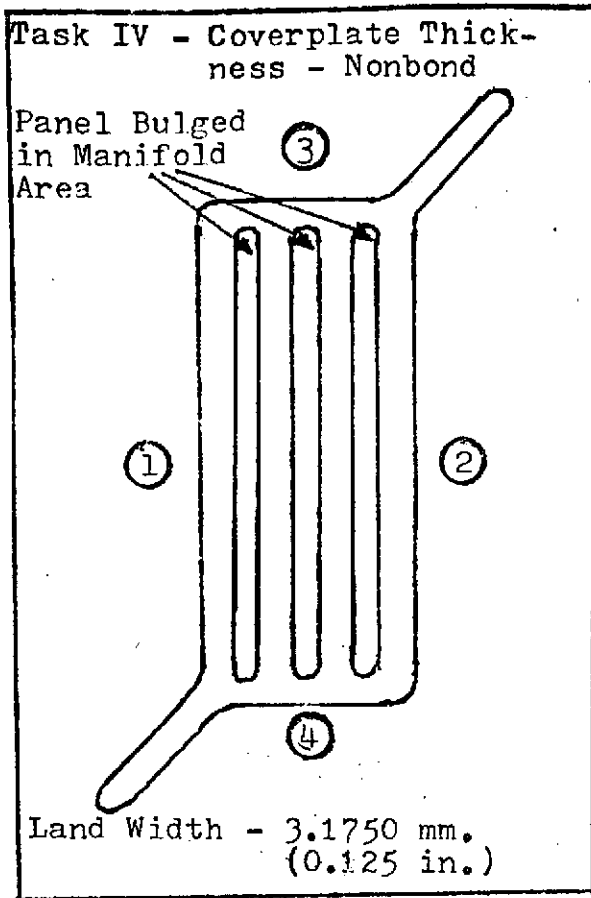


191

Press. 20.7×10^5 N/M²
(300 PSI)

--3

BRAZED PANEL NO. B-11



BASEPLATE

MATERIAL: OFHC Copper

THICKNESS:	MM.	INCHES
①	6.7716	0.2666
②	6.7335	0.2651
③	6.7437	0.2655
④	6.7666	0.2664

COVERPLATE

MATERIAL: 347 Stainless Steel

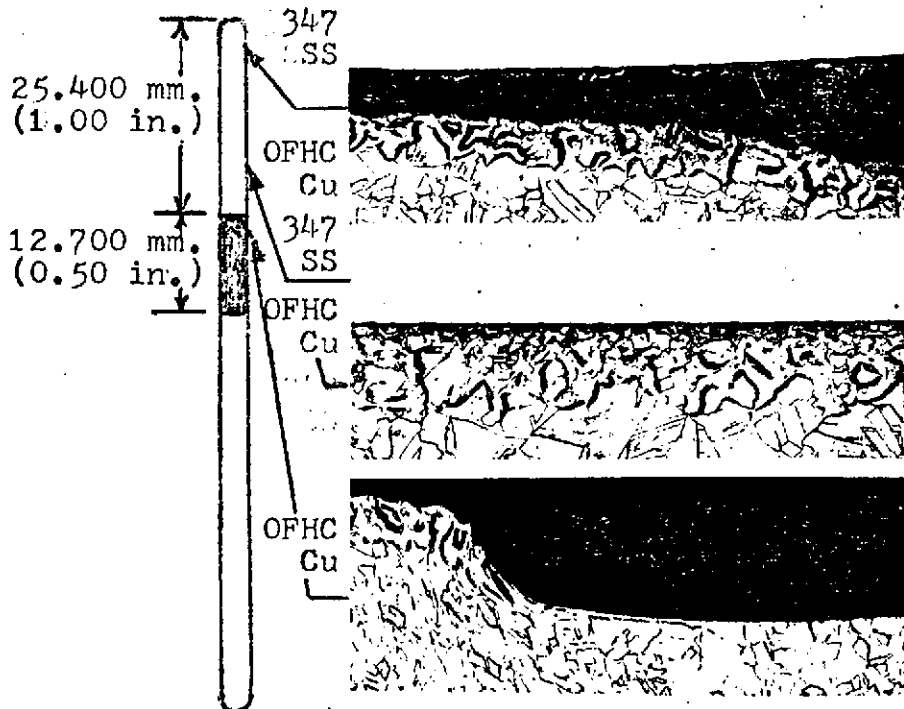
THICKNESS:	MM.	INCHES
①	2.3444	0.0923
②	2.3444	0.0923
③	2.3444	0.0923
④	2.3419	0.0922

PRESSURE REQUIRED TO FAIL BOND:

Bulging occurred at approximately $4.83 \times 10^7 \text{ N/m}^2$ (7,000 psi); the braze failed at $6.90 \times 10^7 \text{ N/m}^2$ (10,000 psi).

CENTER LAND DEFECT

METALLOGRAPHIC ANALYSIS:



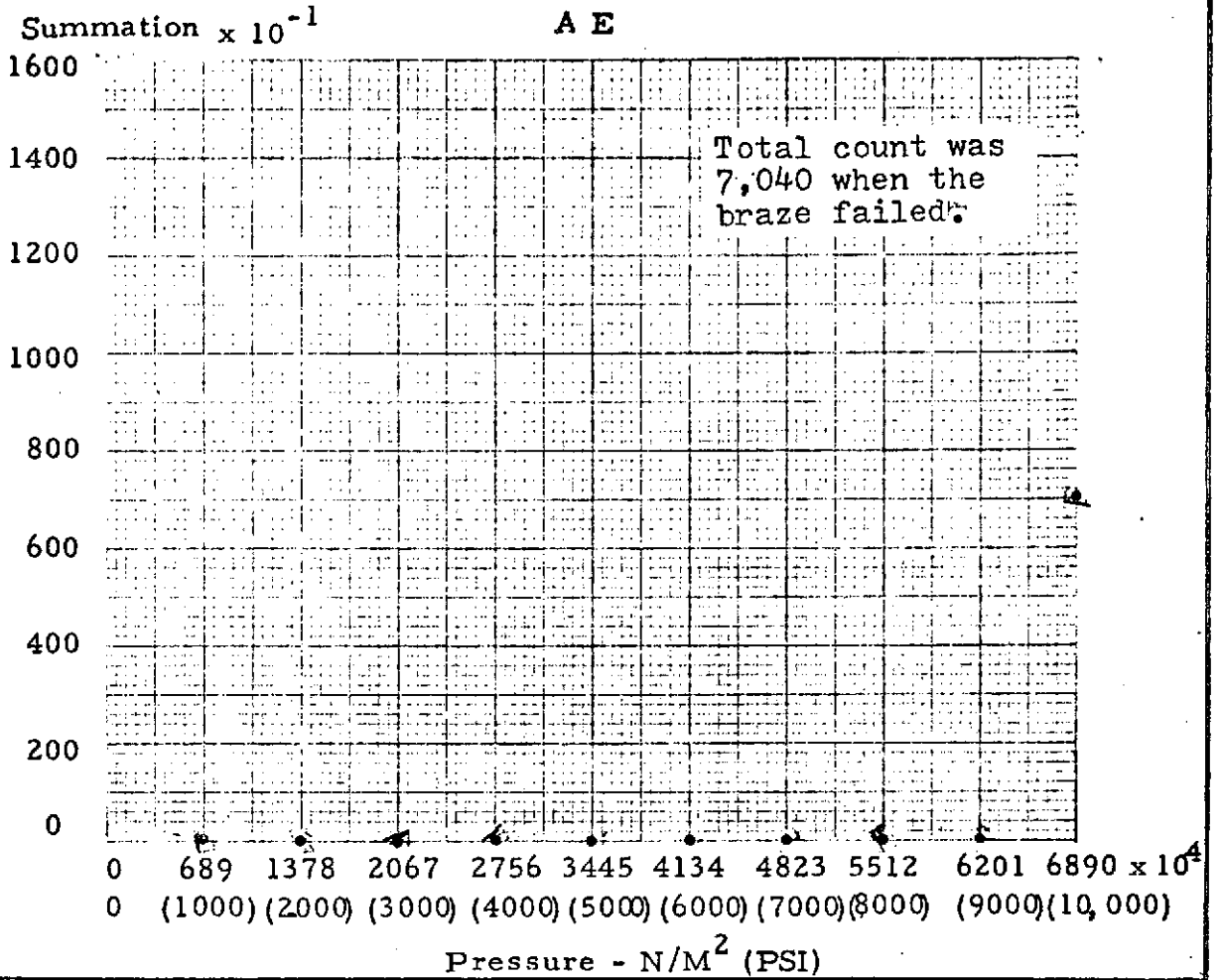
Full bond failure at top manifold end of land. Magnification 50X.

Full bond showing no failure after destructive test. Magnification 50X.

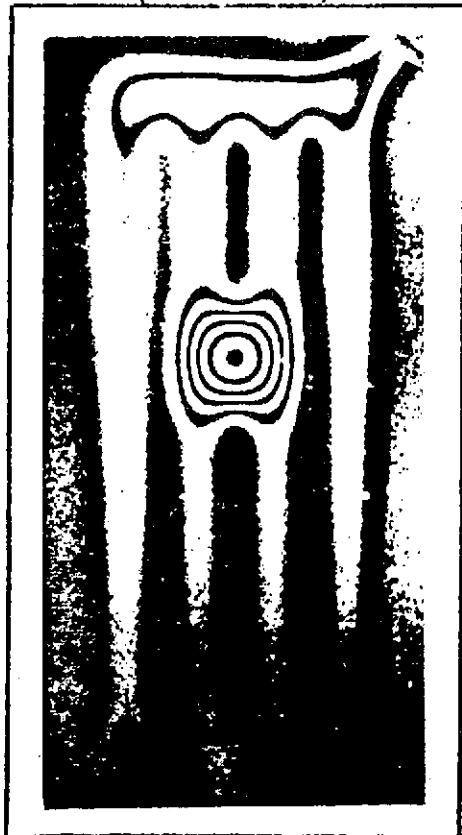
End of planned nonbond defect. No braze wetting is evident in defect. Note yielding of the end bond. Magnification 50X.

FIGURE C-62

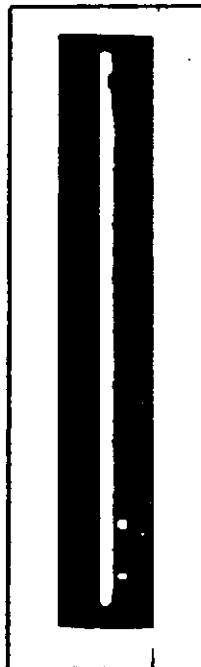
Panel No. B-11



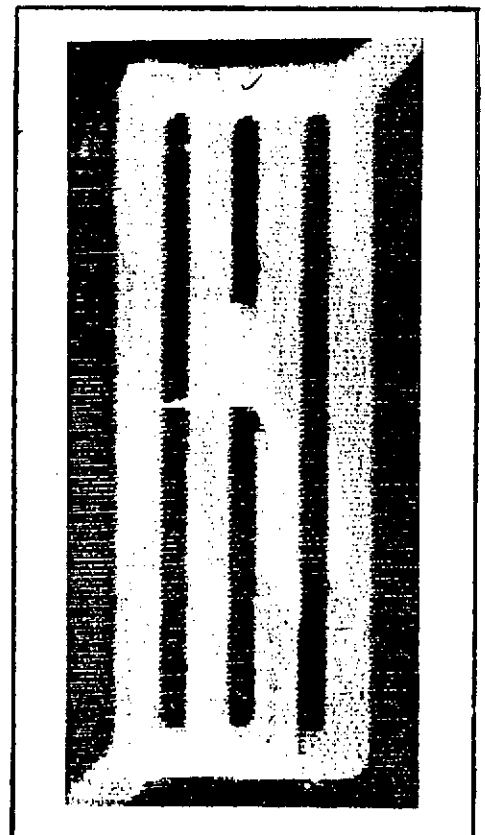
HNDT (Before AE)



AE
FLAW LOCATOR
CENTER LAND



UT



Press. 20.7×10^5 N/M^2
(300 PSI)