

N75 12757

PAPER 4.5

AIROSCOPE STELLAR ACQUISITION

Gordon J. Deboo, Gilbert T. Parra and Roger C. Hedlund
Ames Research Center

ABSTRACT

The acquisition system to be described operates in conjunction with a balloon-borne TV system, boresighted to a telescope. It has two main functions, a star field monitor and an offset star tracker.

The design of the system was strongly influenced by the TV camera, which uses the same interlaced scanning system as is employed in commercial television broadcasting. To reduce power and bandwidth requirements, the star field information transmitted in our system consists only of the horizontal and vertical coordinates of each star and its brightness. As a star field monitor the system provides video thresholding, camera blemish suppression, coordinate digitization in 3 axes, circuitry to recognize as single star the dispersed video signals resulting from one star overlapping adjacent scanning lines and storage of all signals for readout by the telemetry at appropriate times.

The offset tracker generates a set of coincidence gates in the gondola controlled by command from the ground. Coincidences between the gate pattern and the video of the tracking star produce gyro correction signals which force the tracking star to go to and be locked into the center of the gate pattern. The gate pattern is displayed on the ground as a crosshair superimposed on the star field and the operator can move the crosshair to encompass any desired star, which is then forced into the center of the crosshair and, hence the gate pattern. When the operator moves the crosshair, the tracking star and the whole star field move as one. By moving the crosshair, the tracking star can be placed in a predetermined location which positions the object under study in the center of the telescope field.

The acquisition system to be described is part of the Ames Infrared Balloon-Borne Telescope system (AIROscope) introduced earlier in this symposium. It consists of a television camera, a video signal conditioning unit and a gate pattern generator, which combine to perform two main functions. The TV camera and video signal conditioning unit provide signals for a star field monitor, so that an experimenter on the ground can observe and recognize the star field around the field of view of the telescope, which is boresighted to the camera. The purpose of the gate pattern generator is to provide a means for the experimenter to position an IR source invisible to the TV camera, in the center of the camera and telescope fields of view. The camera, the video signal conditioning system and the gate pattern generator are each described below in more detail.

CAMERA

Table 1 on page 4.5-2 summarizes the main features of the TV camera. The specifications having the greatest impact on the design of the star field monitor and offset tracking circuitry are those relating to the interlaced scanning system employed in the camera, which is the same as is used in

commercial broadcasting and which impose similar bandwidth requirements on the rf portion of the AIROscope telemetry. To transmit a complete television picture, including synchronizing pulses and picture information, requires a bandwidth of approximately 6 megahertz. For balloon applications the transmission distances are larger than those typical of commercial broadcasting, being in the range of perhaps 0 to 400 kilometers. It is evident that the transmitter power requirements would therefore also be larger, being in the hundreds of kilowatts range. The power requirements could be reduced by using a very large, tracking, directional, receiving antenna, but this is not available to us, would be too expensive and is unnecessary anyway due to the bandwidth reduction techniques described below in the section on video signal conditioning.

Camera:	Silicon intensified target type.
Scanning:	Standard 525 line, 2:1 interlace, 30 frames per second.
Sensitivity threshold:	10^{-5} F.C. on faceplate.
Zoom:	Remotely controlled zoom to provide 2° to 20° field of view. Detector/telescope FOV is 5° .
Spectral response:	350 to 750 nm, peaking at 420 nm.
Iris:	Automatic iris control based on peak illumination to adjust iris and change neutral density filters to give 100,000:1 dynamic range. Manual control is available.
Reticle:	Four points of light forming a square of $1/2$ to $1/20$ th of picture height depending on zoom setting. Can be remotely turned on or off.

Table 1. Camera Specifications

VIDEO SIGNAL CONDITIONING

The main purpose of the video signal conditioning system is to process the video picture and synchronizing pulse information from the camera electronics so that the star field seen by the camera can be reproduced on a ground-based display without the need for a high power, 6 megahertz telemetry system, since only 30 watts of transmitter power and a few kilohertz of bandwidth are available in the AIROscope system.

Our approach takes advantage of the fact that the number of stars seen by the TV camera in our AIROscope applications is small - we consider 10 to be the maximum required - and further, that any apparent motion of these stars is very slow. Therefore we have a small amount of data and a low data rate which, when combined, require several orders of magnitude less bandwidth to transmit than would the conventional TV signal the camera is capable of handling. The x, y, and z coordinates of each star are measured and stored, where x is the distance from the left-hand side of the picture, y is the distance from the top of the picture and z is the star intensity. To transmit the location and intensity of 10 stars requires 10 xyz measurements or 30 data words. x,y and z are transmitted using the 10-bit words available in the telemetry pulse-code-modulation (PCM) system, so the total bit requirement is $10 \times 30 = 300$ bits for a complete star field. In a noiseless system it would require that the 300 bits be transmitted perhaps every second or less to account for apparent star motion, but to help integrate out noise a complete star field is sent down 30 times per second. This requires $30 \times 300 = 9000$ bits per second, a

data rate which is compatible with the gondola PCM telemetry system. The xyz coordinate data are measured digitally, but are available in the gondola in both digital and analog form. We are currently planning to have the PCM system sample the xyz data in analog form because it simplifies synchronization problems between the camera and the PCM system, which have different and random phase clocks, by eliminating the need for synchronization at all. It should be noted also that coding the star locations and brightness as coordinates eliminates any need to transmit horizontal or vertical sync pulses, which again conserves bandwidth and incidently eliminates the need for a raster in the ground display, thereby clarifying the picture of the star field presented to the investigator.

The measurement of the xyz coordinates involve certain complications, some of which are outlined below to indicate the scope of the electronic design problems. They are most easily discussed by referring to Figure 1. Figure 1(a), which is not drawn to scale, shows two stars A and B being scanned by an interlaced raster consisting of lines 1, 2, 3 and so on. Also shown, in Figure 1(b), are the resulting video pulses and their relationship to the camera synchronizing pulses. Notice that a complete picture requires 525 lines (some of which are lost during the vertical retrace period) and is called a "frame." One frame takes 1/30th of a second to write. Each frame has two "fields" each of which contains 262-1/2 lines taking 1/60 of a second to write. The lines from each field are interlaced to form a frame and in Figure 1(a) the lines of the first field of the frame shown are drawn as solid lines, while the lines of the second field of the same frame are drawn as dotted lines. The main problems illustrated by Figure 1 are the dispersion in time of the signals from 1 star and the interleaving in time of the signals from one star with other stars. The degree of the dispersion and interleaving are functions of how many lines it takes to completely scan a particular star. Because a star is a point source of light and because of the high quality of the TV camera and its optics it should theoretically require only 1 or perhaps at worst 2 lines to cover a given star. However, to allow for such contingencies as a partial loss of focus, our system allows for up to 5 lines being required. This is the situation shown in Figure 1(a) in which stars A and B cover 5 and 2 scanning lines respectively.

Notice that line 3, which is in the first field of the frame shown, scans A but not B. Line 3 on the video waveform therefore has a signal due to A only as shown in Figure 1(b). The next line down on the raster is line 264, but this line does not occur, nor do the video signals resulting from the scan of this line occur, until the second field is scanned about 1/60th of a second later. Line 3 is actually followed in time by line 4, which can be seen to scan both A and B, resulting in two video signals on line 4 of the video waveform as shown in Figure 1(b). By noting which lines scan A and B and where A and B occur on the lines the complete video train for stars A and B for both fields of one frame can be drawn as has been done in Figure 1(b).

The design of a system to measure the coordinates of A and B and other stars must be prefaced by an examination of the waveforms in Figure 1(b). Some of the more important conclusions to be drawn from this examination are listed below.

1. The signals from A and B are interleaved with each other and will interleave with other star signals that may exist. Therefore, we do not have the relatively straightforward situation in which one star is represented by a single signal.

4.5-4
228

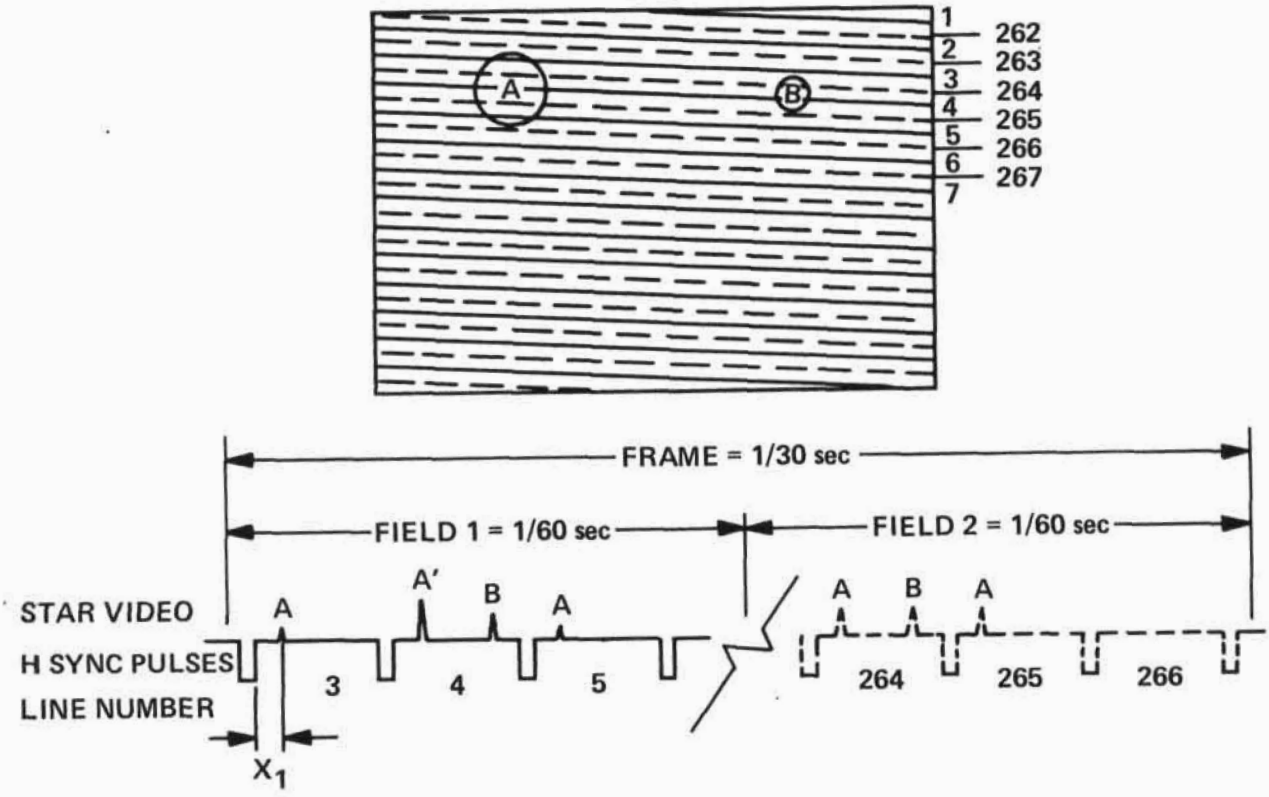

Figure 1. Interlaced scanning of stellar images

2. The amplitudes of the signals from any given star vary depending on how the star happens to be scanned. For the situation shown, the peak of A occurs on line 4, while B has 2 equal peaks on lines 4 and 264, that is, in different fields.
3. To measure the location and brightness of each star we should use only the peak video signal for each star. A has one such peak designated A' on Figure 1(b), while both pulses associated with B are equally large.
4. With a different focus there may be different numbers of lines per star and, depending upon the exact location of a star with respect to the raster lines as it drifts across the screen, the number of lines may change.
5. We must only transmit the location and magnitude of the peak video from each star since to transmit all the A and B signals would require too much bandwidth.
6. We do not know until after we have scanned a star how many lines are required to completely scan it and which line has the peak video.
7. A star with a diameter of one line spacing will have a video signal of a little under 200 nanoseconds duration. Therefore, although the output star field data is slow, on board processing must be fast.

We can infer from these conclusions that we cannot measure the xyz coordinates we need simply by measuring the time between video pulses and synchronizing pulses, thereby obtaining, for example, x_1 in Figure 1(b). The result would be incoherently jumbled data in excessive quantities. To pick a solution to the problem is not difficult, the difficulties occur in picking a solution compatible with the time, money and manpower available and with having to be incorporated in a balloon payload.

A completely detailed discussion of how x, y and z are measured in AIRO-scope is beyond the scope of this paper, but approaches to two problems are outlined here to indicate the general philosophy.

The interleaving problem is reduced if we look only at the data from one field in every frame. For example, referring to Figure 1(b), if we measure only that data in Field 1 of Frame A, we have not only reduced the number of video signals from 7 to 4, but, more importantly from the point of view of simplification, we have reduced the dispersion of the relevant signals from milliseconds to microseconds. However, using the data from only Field 1 of all frames could give rise to certain systematic errors, so we use alternate fields in each successive frame and average the data from them.

If we assume that the largest star image will overlap 5 scan lines, the process of using data from only one field per frame reduces the maximum number of video signals per star per frame from 5 to 3. We can further reduce the 3 signals to 2 by referring to Figure 2, which shows video signal groups from seven possible star/line overlap combinations. Figures 2(a), (b) and (c) are video signals from a star overlapped by three lines of a field. Figures 2(d) (e) and (f) are for two overlapping lines and Figure 2(g) is for a star scanned by only one line.

If there are the maximum of 3 video pulses per star in a field, the second one must be the largest, as is evident from Figures 2(a), (b) and (c), and would be the one we would want to use for an xyz measurement. If there are only 2 video pulses, either the first or second or both could be largest as shown in Figures 2(d), (e) and (f). If there is only one video pulse per star in a field, that is the one one must consider as in Figure 2(g). But we can always be assured of retaining the pulse we need if we adopt the rule that we consider the first one or two pulses per star and not

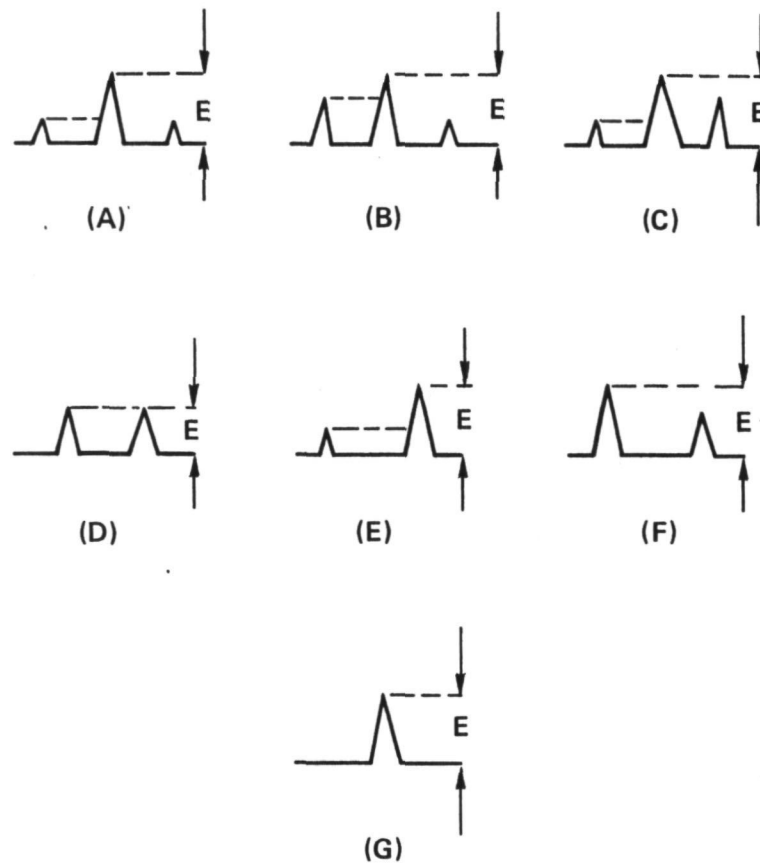

Figure 2. Peak sample and holding

use the third, if it exists. Electronically this can be implemented for the intensity or amplitude measurement z by using a peak sample-and-hold circuit as shown in Figure 2. The peak sampled-and-held voltages E , shown as dotted lines in Figure 2, are always a measure of the largest video signal when that exists.

In addition to the measurement of x , y and z coordinates the video signal conditioning system performs two other main functions - video thresholding and camera blemish suppression.

The video thresholding circuitry permits only video signals above a certain level to be measured. There are eight threshold levels, the minimum being just above the video channel noise level and the maximum being approximately half of full scale. The eight levels are remotely set by telemetered command from the ground and may be used to eliminate extra noise or limit the number of stars displayed.

The silicon intensified target tube has defects called blemishes, which are due to imperfections in the silicon target and their size is expressed in scan lines. For our camera, which uses a 525-line TV system, the blemishes range in size from 1 to 5 lines.

There are two kinds of blemishes - one which does not result in a signal when illuminated and one which produces a signal whether it is illuminated or not. The number of blemishes is small, there being perhaps 10 of each type for the quality of camera we have. The blemishes producing no signal are a minor problem because of their small area and the low probability that a star will image exactly on one of them. Even if this does occur the camera could be zoomed slightly to move the star off the blemish.

The approximately 10 blemishes that produce a signal are more troublesome since they have the effect of producing what look like stars on the ground CRT display. We plan to measure only ten stars and do not have the telemetry bandwidth capability to transmit ten stars plus ten blemishes. Therefore we must eliminate the effect of the blemishes on board the gondola. Since the location of the blemishes is fixed and can be measured, it is possible to arrange for the xyz measurements to be blanked while a blemish region is being scanned. The amount of effective area that must be blanked depends both on the spatial stability of the scanning circuitry in the camera and the accuracy and stability with which a given area can be blanked. We have not completed programming of the blemish blanking circuits, but we are hopeful that we can blank squares having sides of length typically 1% of the screen size. If we can do this, 10 blemishes would result in blanking out only one thousandth of the area of the screen. Again, by zooming slightly, a star could be moved out of one of these blemish regions if necessary.

GATE PATTERN GENERATOR

The purpose of the gate pattern generator is to allow the telescope/detector combination, with its 5 minute field of view, to track an IR source by forcing the boresighted TV camera to offset track a visible star somewhere in its 2 to 20° field of view. Figure 3 helps to show how this is done.

The important parts of the airborne portion of the video/gate system are shown in block diagram form in Figure 3(a). The airborne portion of AIROscope contains, of course, many other systems, but these have been omitted for purpose of clarity. Shown are the telescope and the boresighted TV camera, which has an electronics package whose outputs of interest here are the video signals from stars, blemishes and noise and the various raster synchronizing pulses.

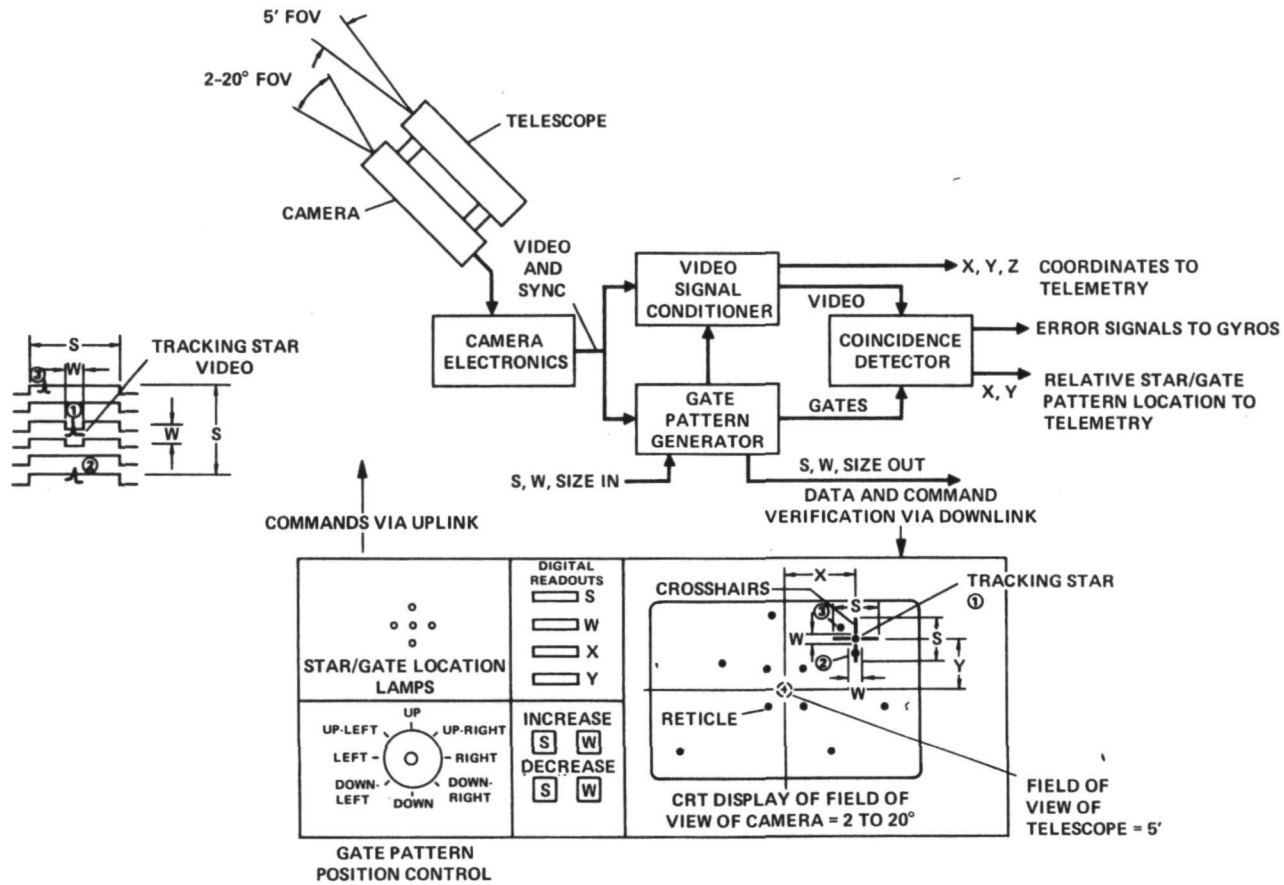

Figure 3. Offset tracking using gate generated crosshair

These outputs go to two systems. One is the Video Signal Conditioner, which digitizes the stellar brightness and location information and which was described earlier in this paper. The other is the Gate Pattern Generator. Each of these two systems has outputs going to a coincidence circuit whose outputs in turn provide error voltages and used to produce gyro correction signals so as to produce the desired tracking.

Figure 3(b) shows some of the ground based parts of the video/gate system. Again the AIROscope ground equipment contains many other systems, controls and displays not shown in Figure 3(b), but they have been omitted for purposes of clarity.

There is a cathode-ray-tube (CRT) display, some controls and some digital and lamp readouts. The CRT is shown displaying two types of data. First, there is an array of 10 stars shown as dots, whose location and brightness are derived from the xyz data measured by the video signal conditioner in the gondola and telemetered to ground. Second, there is a set of what we can refer to as crosshairs surrounding the star selected to be used for offset tracking. The crosshairs have dimensions S and W as shown and coordinates (X,Y,) with respect to the center of the CRT display. Note that the region in center of the CRT display is also the field of view of the telescope and that S, W, X and Y are controlled and monitored on the ground. The position of the crosshair, that is X and Y, is controlled by the joystick in Figure 3(b) and the crosshair can be moved to any location on the display by moving in any of 8 directions, UP, LEFT, UP-LEFT and so on. S and W can be increased or decreased by using the appropriate control shown in Figure 3(b) and X and Y can be read to about 0.2% on the displays shown. These readouts are in plus or minus degrees referred to the center of the display, with scaling provided to allow for camera zooming. W and S are also displayed, but to an accuracy of only 1%. The five-lamp display gives a more accurate indication of where the tracking star is with respect to the crosshairs than can be achieved by observing the oscilloscope. The center lamp comes on when the tracking star is in the center region of the crosshairs and the other 4 lamps come on appropriately to indicate other locations of the tracking star in the crosshair. Of course, in addition to the meter readouts, all quantities can also be monitored by observing the CRT display.

It should be noted that all meter and CRT displays are generated from signals telemetered to the ground from the gondola, not directly from the controls on the command/display console in Figure 3(b). This is intended to give the experimenter some degree of confidence that what he is trying to make happen in the gondola is, in fact, happening.

X, Y, S and W commands are telemetered up to the gondola for reasons other than to inspire confidence in the investigator. These quantities are used to generate a set of gates in the gondola such as are shown in Figure 3(c). Note that the X, Y, S and W commands are all dc-type signals such as "X go LEFT" and "INCREASE S", so that they are all low bandwidth signals and easy to telemeter with the many other commands in the AIROscope time-shared telemetry system. The gate signals they generate in the gondola involve, in some cases, submicrosecond pulse-widths and could not be transmitted up with the AIROscope telemetry.

Note in Figure 3(c) that the dimensions of the gates generated in the gondola are designated X, Y, S and W as are the crosshair dimensions on the ground. On the ground CRT display X, Y, S and W have the dimensions of minutes of arc, but in the gondola the dimensions are microseconds, because the

generation of the gates occurs in time synchronization with the raster generated by the camera. The crosshairs on the ground are a readout of the location and size of the tracking gates generated in the gondola with respect to the camera raster.

Coincidences are performed in the gondola between the tracking star video signal from the camera and the XYSW gate pattern from the gate pattern generator as indicated in Figure 3(c), where a typical set of coincidences is shown. In practice only one star is allowed in the gate pattern at any one time and the tracking mode can be switched out until X, Y, S and W have been adjusted to achieve this, which prevents confusing the tracking gyros. Figure 3(c) therefore shows different locations of the same star in the gate pattern.

With the tracking star video located in time such that it appears in time location 1 in Figure 3(c), the ground display would show the tracking star in the center of the crosshair. Because the star is in the "W" region of the crosshairs, no correcting signal is applied to the gyros and the telescope pointing is unchanged.

If the tracking star were located in time location 2 in Figure 3(c), it would appear in location 2 in the ground displayed crosshair region. Further, because of the coincidence between the star video signal and the gate pattern shown in Figure 3(c) an error signal is generated which forces the telescope and camera to move in a direction that will drop the star video into the gate hole W, where correction signals do not exist.

Similarly the coincidence occurring at location 3 in Figure 3(c) produces error signals which force the tracking star video into the center of the gate region in the gondola and the tracking star display into the center of the crosshairs on the ground.

With maximum zoom the camera field of view is about 120 minutes and W can be set to be as little as 1/240th of that or 0.5 minutes of arc. If the tracking star tries to wander outside this 0.5 minute region it is forced back in by correction signals generated by the gate pattern signal/star video coincidence.

Since the experimenter can move the gate pattern around by adjusting X, Y, S and W and observing the crosshair on the ground display, he can position any star selected as the tracking star on the display somewhere in the crosshair region and it will automatically drop into the center of the crosshair display. If the experimenter now adjusts X and Y, that is moves the crosshair, the whole star field displayed on the ground will move as well. If the coordinates of an IR source, not visible to the TV camera and therefore not displayed on the ground, are known with respect to the tracking star, the tracking star can be moved using the gate pattern X and Y controls so as to position the IR source in the center of the CRT display. This also places it in the center of the field of view of the TV camera and in the field of view of the telescope.

In addition to the mode described in which tracking depends on video/gate coincidences, it is possible to switch to a mode in which the gates can be moved through the star field without generating any error signals. Tracking on a visible star with a conventional non-offset tracker and manual tracking modes are also available.

Since the diurnal motion results in a circular motion of the stellar source about the IR source the gate location must be updated by changing X and Y. This can be done with an onboard timer, but also, as in the case of the current AIROscope, by manual command.

The principle used to generate the offset tracking gates may be illustrated with the help of Figure 4. Figure 4(a) is a block diagram of the

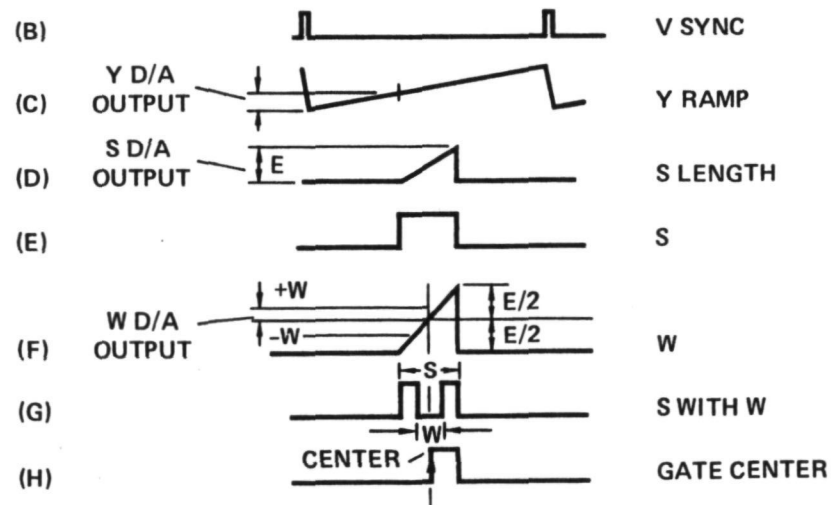
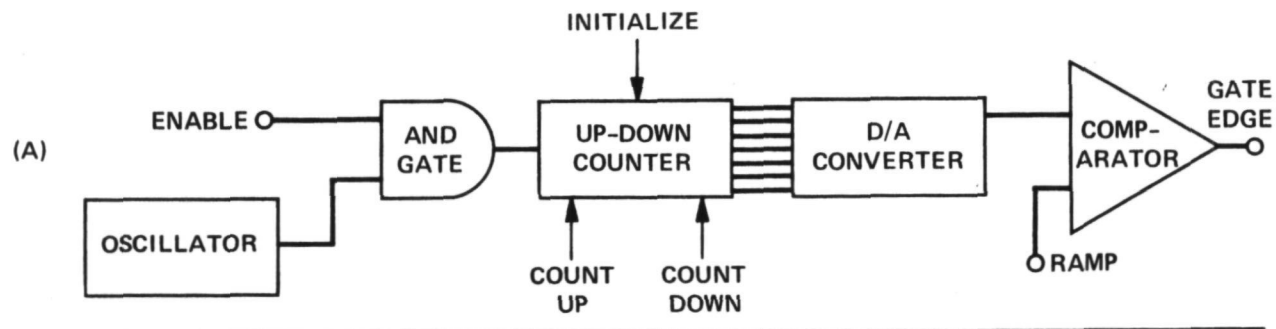

Figure 4. Gate generation

electronics required to generate a typical gate edge and the leading and trailing edges of both S and W gates are generated using similar circuitry. The horizontal and vertical gates used to produce the crosshair pattern are similar to each other, except that the horizontal circuitry is much faster because a vertical sweep takes about 16 milliseconds compared with a horizontal sweep which takes only about 58 microseconds.

An initialize command in the form of a 5-V level change is transmitted to the gondola to set an initial gate position and size. When this command is sent an observer viewing the CRT display in Figure 3(b) would see the gate pattern become centered on the screen with $S=64$ lines and $W=20$ lines. This display is the result of signals telemetered to the ground from the gondola so that a round trip check is provided.

The initialize command is entered into an up-down counter as in Figure 4(a), which causes the counter to feed a preselected count into a digital-to-analog (D/A) converter. The effect of the initialize command is therefore to produce a previously determined voltage at the output of the D/A converter and at the input of the comparator of Figure 4(a).

The other input of the comparator is fed with a ramp such as that in Figure 4(c), which is a sawtooth waveform synchronized with, in the case shown, the vertical sync pulses of Figure 4(b). When the voltage on the ramp input of the comparator equals the preselected Y D/A output voltage on the other input two things happen. A second ramp is started as in Figure 4(d) and the leading edge of S is generated as in Figure 4(e). The second ramp in Figure 4(d) is allowed to sweep up until it reaches a second preprogrammed, preselected level E derived via an S D/A converter from an S up-down counter. At this point the ramp in Figure 4(d) is reset and the trailing edge of S is generated, resulting in the S gate of Figure 4(e). The Y and S up-down counters are preprogrammed in such a way that, in response to an initialize command, waveform S in Figure 4(e) is exactly centered between the vertical sync pulses in Figure 4(b), thereby placing the vertical component of the crosshair in Figure 3(b) in the center of the CRT display.

The W portion of the crosshair display again uses an up-down counter, a D/A converter and a comparator system. The W D/A converter is preset by initializing an up-down counter producing a predetermined voltage $+W$ from which $-W$ is derived so that both plus and minus W are available simultaneously. The ramp in Figure 4(d), whose amplitude is E, is offset by exactly $E/2$ and compared with the $+W$ and $-W$ voltages as in Figure 4(f). The resulting comparator outputs are used to generate a hole in the S waveform of Figure 4(e), resulting in the waveform in Figure 4(g). It is the waveform of Figure 4(g) that is used to generate the vertical component of the crosshair of length S with blanked center portion W in Figure 3(b).

In order to measure the position of the gate for display on the Y digital readout in Figure 3(b) the gate center is required. This is shown in Figure 4(h) and is readily obtained by level comparison from the waveform in Figure 4(f).

In order to change the location of the gate pattern the Y up-down counter is placed in the count-up mode to move down, or the count-down mode to move up, and fed with pulses from the oscillator of Figure 4(a). This changes the D/A reference voltage level at the comparator input and causes the comparison shown in Figure 4(c) to slide right or left, thereby moving the S gate with respect to the vertical sync pulses and the crosshair with respect to the stellar display in Figure 3(b). From the waveforms in Figure 4 it is evident that this motion of the S gate does not result in a change in the lengths W

and S. They are changed by up-down counting of the W or S counters. The gate pattern location and W and S may all be changed independently. S and W are in fact increased or decreased by holding down the appropriate command button in Figure 3(b), and the gate position is changed using the command joystick on the same figure. All these commands result in logic inputs to the up-down counters in the gondola.

For the Y or vertical component of the crosshair we have described the need for Y, S and W up-down counters, Y, S and W D/A converters and Y, S and W comparators. It is only necessary to add an X counter, converter and comparator to generate the X horizontal component of the crosshair, since the S and W circuitry are common to both X and Y directions.

The crosshair can be moved to any region of the CRT display at either 1 or 10 lines per second and stops are provided to prevent it going offscreen. Dimension S can be varied over a range of 5 to 64 lines and W from 2 to 20 lines, both at 1 line per second.

SUMMARY

A system for providing ground display of a star field and offset tracking has been described, which uses a modified standard TV camera as its input. The star field information is telemetered accurately over long distances from a relatively low power transmitter by using digital bandwidth reduction techniques. Offset tracking is accomplished by forcing a selected tracking star into the center of a gate/crosshair system by means of which the tracking star can be moved to a predetermined location so as to position the source under study in the center of the telescope field of view.

ACKNOWLEDGEMENTS

The principle of offset star tracking using a coincident gate system to generate error signals was suggested by Charles Swift of the Astrophysics Branch at Ames Research Center.

DISCUSSION SUMMARY — PAPER 4.5

In answer to questions about the sensitivity of the television camera, it was noted that the system is expected to be able to guide on stars as faint as eighth magnitude. Since there are, on the average, 0.25 eighth magnitude stars per square degree and the smallest field-of-view is two-degrees across there would usually be a bright enough star in the field-of-view. In cases where this is not true, the zoom capability (to twenty-degrees) would presumably bring an eighth magnitude star into the field-of-view.

A number of questions about details of the camera and the responses are summarized below:

Q. What is the power consumption of your camera?

A. Thirty watts.

Q. Has the SIT been tested in the balloon environment?

A. It has not been tested by us, but the camera manufacturer gave the whole camera an environmental test. It is hermetically sealed in an enclosure at one atmosphere pressure.

Q. Is the TV system being constructed here and what is its cost?

A. The TV acquisition and stabilization system was designed and built at Ames. The electronics are completed. The cost of the parts for the electronics was \$7500 and for the camera itself, \$22,000. The latter includes the cost of the tube which was \$6000. It was pointed out that cheaper tubes are available. The cost of the tube depends inversely on the number of blemishes.

Q. What is a blemish?

A. A blemish is a defect in the silicon lattice which is used in the intensification process in the tube. There are two kinds of blemishes. One kind fails to give you a signal when you illuminate it. The other kind gives you a signal whether you illuminate it or not.

Q. How many bits of information are used to determine brightness of stellar images?

A. We transmit 10 bits, but we can't use that many because the cathode ray tube is the limiting factor, probably at 64 to 1.

Q. What is the deadband of the servo control?

A. It is about a half a minute of arc.