

FINAL REPORT

GRANT: NGR-14-001-250

Development of an Alpha Scattering  
Instrument for Heavy Element Detection  
in Surface Materials

by

Anthony L. Turkevich, Principal Investigator  
Thanasis Economou, Edwin Blume and Wayne Anderson

The Enrico Fermi Institute  
The University of Chicago  
Chicago, Ill. 60637

December 1974

(NASA-CR-141009) DEVELOPMENT OF AN ALPHA  
SCATTERING INSTRUMENT FOR HEAVY ELEMENT  
DETECTION IN SURFACE MATERIALS Final  
Report (Chicago Univ.) 50 p HC \$3.75

CSCI 14B G3/35

Unclass  
03649

N75-13216

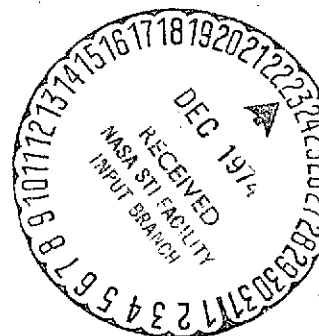

## INTRODUCTION:

In recent years, concern about lead poisoning in young children has led to an interest in portable instruments that can detect and measure the amounts of lead in surface materials such as paints used in dwellings and in children's toys.

The Alpha Scattering Experiment on the Surveyor Lunar missions demonstrated that the elastic scattering of alpha particles can be used for quantitative elemental analysis of surface materials. In 1972 it was realized, however, that small adaptation in the instrument could lead to detection of lead and other poisonous heavy elements in surface materials.

The idea was first proposed to NASA in 1972. NASA, consequently, through its' Office of Technology Utilization obtained a small grant from HUD for the development of two prototype instruments.

The principles underlying such an instrument are described in the attached Science reprint (Heavy Elements in Surface Materials: Detection by Alpha Particle Scattering. Thanasis E. Economou, Wayne A. Anderson, Edwin M. Blume and Anthony L. Turkevich, Science 181, 156 (1973).

The work done, and the results obtained during the covering period are described in the attached Principles of Operation and Instruction Manual.

The two prototype instruments were delivered to HUD (through NASA) on June 1974.

Although the quality of  $\text{CM}^{244}$  alpha sources obtained from Argonne National Laboratory and used in the instruments was not as high as desirable (see manual for details), the results obtained with the instruments are satisfactory in demonstrating the capabilities of this type of an instrument.

Currently, the instruments are undergoing evaluation at National Bureau of Standards and at the Goddard Space Flight Center.

ALPHA SCATTERING HEAVY ELEMENT DETECTOR  
(ASHED)

Principles of Operation and Instruction Manual

by

Anthony Turkevich

Thanasis Economou

Edwin Blume

Wayne Anderson\*

The University of Chicago, June, 1974

\*Present affiliation: Dietzgen Corporation  
Chicago, Illinois 60614

Table of Contents

	<u>Page</u>
I. Introduction	1
II. Principles of the Method	3
III. Description of the Instrument	6
A. Sensor Head	6
B. Electronics and Associated Servicing Facilities	7
IV. Detailed Description of Critical Components	8
A. Sensor Head	8
1. The alpha radioactive source in its collimating container	8
2. Surface barrier silicon detector and films	9
3. Mechanical shutters	11
B. Electronics	12
1. Amplifiers	12
2. Discriminator	13
3. Read-out system	15
4. Timer	15
C. Battery Pack and Voltage Regulator	16
D. Battery Charger	17
V. Operating Instructions	18
VI. Interpretation of Measurements	20

	<u>Page</u>
VII. Tests and Contingency Procedures	22
A. Tests with closed shutters	22
B. Tests with calibration source	22
C. Test with a pulser	23
D. Test with a paint sample	23
VIII. Figure Captions	25
IX. Appendices	
1. Reprint from Science	26
2. Spectra of Cm-244 alpha sources	27
3. Electronic Drawings	28
4. Calibration Curves	29
5. Mechanical Drawings	30

## I. Introduction

An instrument for the detection of heavy elements in surface materials (e.g. Pb, Bi, Tl, etc.) has been constructed based on the principle of back-scattering of alpha particles from a radioactive source. The technique is essentially the same as was used to obtain the first chemical analyses of the lunar surface on the Surveyor unmanned missions in 1967-1968.

A demonstration instrument, built up with spare Surveyor electronic parts was constructed in the summer of 1972 and demonstrated that fall to NASA and other U. S. Government officials. It was described in a paper in SCIENCE in 1973 (Economou et al., 1973, Appendix 1). Based on this work a grant was obtained from HUD through NASA to construct two instruments.

This report recalls the principles of the technique, summarizes the advantages and disadvantages of the technique, describes the instruments as constructed, provides operating instructions and calibration curves, and gives contingency procedures for dealing with possible malfunctions.

The present Alpha Scattering Heavy Element Detector Instrument (ASHED) is pictured in Figure 1. It consists of a detachable cylindrical sensor head and a rectangular box containing most of the electronics, display counter, timing unit and battery and charging accessories. The instrument weighs one kg, has a volume of  $\sim 800 \text{ cm}^3$  and can operate up to 40 hrs on one battery charge.

The presence in the instrument of an alpha radioactive source of around 3 mc strength requires that precautions always be taken not to direct it at bare skin with the shutters open. There is negligible radioactivity escaping from the instrument with the shutters closed.



## II. Principles of the Method

The principle on which the instrument operates is described in the accompanying reprint from SCIENCE magazine (Economou et al., 1973). It depends on the fact that when mono-energetic alpha particles (from a radioactive source) are back-scattered from a sample, the alpha particles come back with an energy that is higher the greater the atomic weight of the element doing the scattering. The alpha particles are detected by a semi-conductor silicon detector which puts out an electrical signal whose size is proportional to the energy of the alpha particle entering it. Each alpha particle entering the detector is registered separately. Electronic discrimination can allow only alpha particles above a certain minimum energy to be recorded, and thus the presence of elements with atomic weight greater than some threshold value (in our case Zn or Ba) to be detected. The intensity of scattering is greater for the heavier elements, thus providing extra sensitivity for these.

Because of the low penetrating power of alpha particles, the instrument measures only the heavy element content of the topmost layer (~ 1 micron) of the surface, but is quite sensitive to the heavy element content in this top layer. Thus, it is particularly suitable for detecting the heavy element content of the top layer of paint, for example on a wall or on a toy or child's crib.

The present instrument is constructed with two thresholds: the "Lo" threshold responds to the presence of all elements heavier than about zinc - but with greater sensitivity for the heaviest elements. In this "Lo" mode, with a suitable source, less than 0.5% of Pb can be detected in 1 minute measurement. If this first measurement with "Lo" mode indicates the presence of heavy elements, the "Hi" level mode will enable one (on a longer time measurement) to make sure that the heavy element present is indeed heavier than barium.

This particular mode of operation has been a first-cut attempt to compromise between quick response and specificity to particular elements. It might be remembered that, not only lead, but most chemical elements in the heavy region of the periodic table (e.g. Hg and Tl) are also poisonous, so that their presence in amounts greater than a few tenths of a percent should be of interest. In any case, evaluation of the present instruments should provide information on the possibly different threshold settings that would be most useful.

The instrument consists of two portions: A) the sensor head and B) the electronics and associated servicing facilities (display unit, battery and voltage regulator and charging facility). The sensor head has in it the radioactive source ( $^{244}\text{Cm}$  in the case of the present instruments) and an annular silicon detector. The source and detector are protected by

thin films, as well as mechanical shutters. The general relationship of these is shown in Figure 2.

As indicated in the detailed description, the present instruments deviate from those that could be built because the quality of the  $^{244}\text{Cm}$  sources that were obtainable was not as optimal (either in intensity or spectral purity) as desired (appendix 2). Future instruments should use either higher quality  $^{244}\text{Cm}$  sources, or else another alpha emitting radioisotope, e.g.  $^{242}\text{Cm}$  could be used.  $^{242}\text{Cm}$  can more easily be obtained in high quality, but is more expensive and has a shorter half-life ( $\sim 163$  d), requiring a calibration curve that changes (in a known way) with time.

A final remark in this introduction should be made about the alpha radioactivity in the instrument. This is of the order of several millicuries. Since alpha radioactivity is easily absorbed, there is normally no health hazard from it unless biological material is exposed to the unshuttered source. Considerable care has been expended to ensure that the alpha radioactivity not escape from the instrument, and tests for the integrity of the sources are included (see below). If there is evidence of escape of the radioactivity the instrument should be packaged and serviced by competent personnel.

The external radiation from the instrument is low,  $< .3$  mr/hr gamma ray at contact on outside of instrument.

### III. Description of the Instrument

The principle of the ASHED Instrument has been described in the SCIENCE article (Economou et al., 1973) and in Section II above. The three parts (Sensor Head, Electronics, and Associated Servicing Facilities) are described in some detail in this section.

#### A. Sensor Head

The sensor head is the active part of the instrument. It contains the radioactive source, the solid state detector, protective films, mechanical shutters and the first stage of the electronics. Figure 1 shows a picture of the sensor head. The geometrical relationships of components inside the sensor are illustrated in Figure 2. The detailed mechanical drawings are furnished separately in appendix 5.

The sensor head is a cylinder ~ 4.5 cm diameter and about 5.5 cm high. The components are:

1. The alpha radioactive source in its collimating container with protective films to assure containment of the alpha radioactivity.
2. The annular detector, also with a protective film.
3. Two separate mechanical shutters, one to be interposed between the radioactive source and all other parts of the instrument, the other to expose the sample to be examined. Levers on top of the sensor head operate, separately, these shutters.

4. The first stage of electronics to provide the processing of the signal from the detector.

5. An umbilical cord connecting the sensor head with the main instrument box.

B. Electronics and Associated Servicing Facilities

The main instrument box contains most of the electronics, the display, counter, timing units, the battery and charging accessories.

Some of these components will be discussed in some detail in the next section.

#### IV. Detailed Description of Critical Components

##### A. Sensor Head

1. The alpha radioactive source in its collimating container.

The requirement of such an instrument is for an alpha radioactive source of high intensity and high enough monochromatic energy. The demonstration instrument (Economou et al., 1973) used  $^{242}\text{Cm}$  at a strength of 4 mc. This nuclide has the advantage of relatively high energy (6.1 MeV) of high specific activity so that sources of high quality can be prepared. It is, however, expensive, and the short half-life (163 days) would require correction for decay during field use, and relatively frequent replacement of the source.

The preset instruments have in them  $^{244}_{96}\text{Cm}$  ( $t_{1/2} = 18$  yr, alpha energy 5.8 MeV). Instrument 1 has 4.4 mc of alpha activity; instrument 2 has 3.7 mc. Neither the source strength ( $\sim 1/3$  of that for which the instrument was designed) nor the quality (see appendix 2) are of desirable (or, possible) quality but were the best that could be obtained for these instruments. They were prepared at the Argonne National Laboratory. The performance, particularly of instrument 2, is therefore considerably degraded over that which is possible.

The alpha radioactivity is mounted on a platinum plate by an evaporation technique (instrument 1) or by electrodeposition

(instrument 2). After depositing the radioactivity, the sources were covered with a 900 Å film of graphite to help cut down recoil transfer of the radioactivity from the source to other parts of the instrument. In front of the alpha source is a collimator that restricts the emitted alpha particles so that they strike only the opening in the bottom of the instrument head. The collimator is made of stainless steel. It is 1.75 mm long, has an ID of 3.75 mm and has walls 130 μ thick. A mechanical shutter (see Fig. 2) can be interposed between the source and the collimator.

There are two sets of thin films to further assure the containment of the radioactivity. One is at each end of the collimator. The films each consist of a combination VYNS - Al<sub>2</sub>O<sub>3</sub> having a combined thickness of ~ 1200 Å. Visual inspection (with source shutter closed) may reveal wrinkles, but there should be no breaks visible. The source shutter should be kept closed whenever the instrument is not in actual use in order to cut down the exposure to radiation of the films. Laboratory experience has indicated lifetimes for such films of up to a year.

## 2. Surface barrier silicon detector and films.

A solid state detector of the silicon surface barrier type is used to register the pulses from the backscattered alpha particles. To achieve an optimum geometry for the instrument,

a small circular detector with a hole in the center is used. The source collimator protrudes through this hole (see Fig. 2). The detectors in the present instruments were made at the Laboratory for Astrophysics and Space Research of the University of Chicago and are of the type used for space applications. They have been made from 0.5 mm thick silicon crystals and have an evaporated gold surface on each side to provide electrical contact. The sensitive area of the detectors is about  $2.0 \text{ cm}^2$ , (although only a fraction of this is actually used in these instruments); the sensitive depth is  $100 \mu$ . The detectors operate with an applied bias of 5-12 volts. Such detectors have the property of producing an electrical impulse whenever a charged particle such as an alpha particle enters them. This impulse is proportional to the energy of the particle.

The detectors are very fragile and have to be handled with care. To protect them primarily from dust, a thin film ( $\sim 3 \mu$  thick kimfol foil) is placed in front of the detector. This film is plated with a very thin layer ( $\sim 100\text{-}200 \text{ \AA}$ ) of gold to cut down the sensitivity of the detector to light and to reduce static electricity accumulation which might lead to accumulation of dust on the surface of the film.

It is most important that the instrument films not come in contact with the measured sample or other material. If, for some reason, the films break, the instrument should be sent



back for service. Failure to do so may result in misinterpretation of the data, permanent damage to the detector, or, most serious, contamination of the instrument with alpha radioactivity.

### 3. Mechanical shutters.

There are two shutters on the sensor head that can be operated either simultaneously or individually (Fig. 2). The purpose of the shutters is to protect the fragile parts of the sensor head (detector and films) and to reduce the exposure of the films and opening of the sensor head to radioactive alpha particles when the instrument is not in operation.

The source shutter (top in Fig. 2) is made of 130  $\mu$  stainless steel and is located between source and the first  $\text{Al}_2\text{O}_3$ -VYNS film on the collimator. When this shutter is closed there are no alpha particles coming out from the instrument. The source shutter can be opened and closed independently from the other shutter, making it possible to inspect the detector and films for any damage. It also makes possible checks on the detector behavior (see below) and assurance that the alpha radioactivity is not escaping from the source.

The other shutter - the sample shutter - is located at the opening of the sensor head. It is thus between the sample and the detector. Its function is to protect the detector and films from physical damage. This shutter should always be kept closed except during actual measurements.

Care should be exercised to minimize exposure of any part of the human body to the alpha particles from the sources even though the range of alpha particles is less than the dead layer of skin. The most important radiation and health aspect of the instrument is the early detection of any escape of radioactivity from the sources. This should be easily noticed by the tests to be described below.

### B. Electronics

The purpose of the electronics is to process the electrical impulse that is the output of the detector when an alpha particle enters. This processing consists of selecting only those events that are above a certain threshold energy, and recording the number of such events in a preset time (1 or 5 min). The instrument uses modern solid state integrated electronic circuitry, some of which was developed for space applications. Fig. 3 shows the logic diagram of the electronics. The electronics consist of preamplifier and postamplifier which are located inside the sensor head; a Schmidt trigger discriminator and a counting system. The detailed electronics circuitry is attached in appendix 3.

#### 1. Amplifiers.

A charged sensitive preamplifier with a rise time constant of 1  $\mu$ s is used to shape and amplify the weak signal collected from the solid state detector. A second amplifier

is then used to achieve the desired amplification of the signal. Figs. 4 and 5 in appendix 3 are the detailed electronic schematics and also the physical layout of the components on the printed circuit boards for preamplifier and amplifier, respectively. Both of these amplifiers are in the sensor head. The output from the sensor head is a negative gaussian shaped pulse of about 10 V. It is fed by a shielded cable into a Schmidt trigger type discriminator on PCB-3 and the output can be examined via test point TP on the back of the instrument when the battery is removed from the instrument. For a quick check of the entire electronic and counting system of the instrument another test point is provided on the sensor head for connecting a pulse generator. (Microdot connector is required.)

## 2. Discriminator.

A Schmidt trigger-type discriminator is used to cut out all the signals from the alpha particles scattered from light elements. Only alpha particles with sufficiently high energy, scattered from heavy elements, can trigger the discriminator which opens the counting gate.

A variable discriminator control (R3 and R4 on the back of the instrument) makes it possible to select the element to which the instrument becomes responsive by setting the electrical threshold for acceptable events.

There are two levels of discrimination provided in this instrument. They are selected by a switch on the front panel of the instrument ("Lo" or "Hi" Energy Level). At present, they are set so that the instrument responds to all elements heavier than zinc and barium, respectively. These two elements were selected because some of the commonly used paints contain either lead, or barium, or elements with atomic numbers of zinc or lower.

The sensitivity of the instruments for heavy elements is a function of many factors, one of which is the discrimination setting. The higher the setting, the lower the sensitivity, and vice versa. The counting rate with the "Lo" level is high and a counting time of only 1 minute is enough to set a limit for the presence of heavy elements in the region of lead of a few tenths of a percent. However, the "Lo" level responds also (with lower sensitivity) to the presence of barium. In the "Hi" level, the instrument is essentially insensitive to barium, and so the presence of heavier elements can be confirmed. Because of the lower sensitivity of "Hi" level in the present instruments, with their less than optimal source strengths, about 5 minutes counting time is needed to achieve the sensitivity of less than half percent of lead.

A sign of - ("Lo") or + ("Hi") on the first digit of the display indicates which of the two energy levels is being

used by the instrument. A toggle switch on the face of the instrument changes from one to the other.

### 3. Read-out system.

The read-out system consists of a three-and-a-half digit decade counter. This registers each alpha particle scattered from a sample with an energy above the selected threshold, and presents it via a liquid crystal display (Fig. 3). One half of the fourth digit (on the left) is used to indicate an overflow so the counter can handle up to 1999 events. Above that one has to keep track of the number of thousands. The other half of the left digit is used to indicate the status of the instrument. An arrow pointing to the left ( $\leftarrow$ ) on the display appears when the START button is pressed and stays there for the entire duration of counting. A plus (+) or minus (-) sign indicates which of the two energy levels is being utilized, "Hi" or "Lo", respectively. The liquid crystal display was chosen for its low power requirement, so the display can be left on for the entire duration of counting. Fig. 6 in appendix 3 shows the block diagram of the entire electronic system.

### 4. Timer.

To simplify the operation of the instrument, an internal timer is provided which stops the measurement automatically after either one or five minutes have elapsed, depending on the position of the time switch on the front panel

of the instrument. If the switch is on  $\infty$  position, then the counting has to be stopped manually by pressing the STOP button. The total number of events registered remains shown on the liquid crystal display until it is erased or the power on the instrument is turned off. The end of the counting is indicated by the disappearance of  $\leftarrow$  in front of the liquid crystal display.

### C. Battery Pack and Voltage Regulator

The battery pack consists of 14 600 mah Ni-Cd, 1.2 V rechargeable cells connected in series. Thus, the voltage supplied from the battery is between 16 and 18 volts, decreasing somewhat as the battery is discharged.

The threshold level of the discriminator and also the gain of the electronic system change with decreasing voltage, and this would affect the behavior of the instrument. To avoid this effect, a voltage regulator is incorporated which keeps the voltage constant at 12.0 Volts as long as the battery delivers voltage at least + 12.0 V. At that point a warning appears in the display crystal, with all decimal points showing up. The use of the instrument should then be discontinued and the battery recharged.

The total current needed to operate the instrument is about 15 mA. This means that the instrument can be operated continuously for about 40 hours, or for one normal work week, with a single battery charge.

D. Battery Charger

A charger is provided with the instrument for battery charging. Fig. 7 in appendix 3 shows the schematics of the charger. The input voltage required is 110-130 AC and the output voltage is about 60 VDC. For full capacity charging of the battery, a charging period of at least 20 hours is required. A longer period of charging will not harm the battery.

The battery pack was designed so that it can be plugged directly into the charger. A light indicator is On when the charging circuit is activated.

## V. Operating Instructions

Following are normal operating instructions for the ASHED:

### 1. "Power ON"

The power is turned ON and OFF by a switch in the front panel of the instrument. This will, also, activate the liquid crystal display, but not all digit sections will come on properly. Some switches are of the "lift to switch" type, to prevent accidental resetting.

### 2. "Reset"

The Reset button will always clear the display and properly activate all digit sections. Zeros will appear on the display.

### 3. Sample Preparation.

The ASHED is designed to examine about  $1 \text{ cm}^2$  of a flat sample either solid or in powder form, pressed to form a flat sample.

The sensor head is detachable from the rest of the instrument in order to reach less accessible but flat places. It must be kept in mind that, to get correctly interpretable readings, the sensor head should sit directly on the examined sample with no space between the head and the sample.

4. The two mechanical shutters (the source and sample shutters) are operated by a lever on the top of the sensor



head. Turning the lever to the open position all the way until it is locked by a wire spring will open both shutters. This will allow the beam of alpha particles to stream through the opening on the bottom of the sensor head and impinge on the sample. In this position, care should be exercised to prevent any radiation exposure to human body.

After the measurement is complete, the shutters should be closed by shifting the shutter lever to the "closed" position. The shutters should be kept closed except during actual sample measurement.

The above operation of the shutter lever on top of the sensor head operates both shutters simultaneously.

See below for the procedure for operating the shutters separately.

5. "Start" - Pressing the start button initiates the registration of events in the detector and starts the internal clock. The measurement will stop automatically after 1.0 or 5.0 minutes, depending on the position of the time switch.

6. "Stop" - Pressing the stop button terminates the measurement manually. It is recommended, when first turning on the power of the instrument, to press the stop button, reset the display by pressing the "Reset" button, and then start the measurement.

## VI. Interpretation of Measurements

At the time of delivery, the background measurement of the instrument (made with a "heavy-metal-free" material such as polyethylene), is quite low. For example, for instrument SN/1 it is about  $0.26 \pm 0.06$  c/min in the "Lo" threshold mode, and  $(0.14 \pm 0.11)$  c/5 min in the "High" threshold mode. These backgrounds can be neglected except at low concentrations ( $< 0.5\%$  Pb) of heavy elements.

"Low" threshold measurements. These are designed to obtain a rapid answer to the question "are there any chemical elements heavier than zinc in the surface material being examined?" The calibration of Instrument SN/1 provides the following interpretation of a reading in the "Lo" mode

14 c/m means 1%Pb by weight, or  
5% Ba

with intermediate values of intermediate elements. It is clear that at about the 1 c/m level (implying  $\sim 0.1\%$  Pb) a 5 minute measurement in the "Lo" mode should be made to make sure that the events observed were not statistical fluctuations.

If the "Lo" threshold measurement warrants further identification, the switch is made to the "Hi" threshold mode of the instrument. Except at the highest concentration ( $> 5\%$  Pb), this will require a 5 min measurement. In this mode, 1% Pb will give 5.0 events in 5 min, whereas 5% Ba will lead to 2.3 events in 5 minutes.

For convenience, Figs. 8 and 9 can be used to convert intensity into weight percent of lead for "Lo" and "Hi" thresholds, respectively.

Remembering the principles on which the operation of the instrument are based, it is clear that a positive reading with the "Hi" threshold indicates the presence of some element heavier than Ba, with a relative sensitivity roughly that shown in Fig. 2a of Economou et al.: (1973).

## VII. Tests and Contingency Procedures

### A. Tests with closed shutters

With both shutters closed, turn power on and take a one minute measurement with energy threshold on "Lo" position. If there are no counts or only one or two, this indicates that the instrument is behaving normally, and there is no contamination.

The presence, repeatedly, of more than two events in a 1 minute measurement with both shutters closed indicates a malfunction in the instrument. This could arise either from radioactive contamination or from electronic malfunction.

To check on the possibility of radioactive contamination, the sample shutter should be opened (while keeping the source shutter closed) and the condition of the two films over the source collimator examined. Although these may show wrinkles, they should not be broken. If broken, the instrument should be sent back for servicing.

Electronic malfunction may arise either from noise developed in the detector or picked up in the electronics. A noisy detector may be indicated if the "shutter closed" reading is abnormal in the "Lo" threshold mode, but not in the "Hi" threshold mode.

### B. Tests with calibration source

A Cm-244 calibration source with a total intensity of only about 400 d/min is provided to check periodically the behavior of the detector. The procedure is the same as for

the sample measurement except that the source shutter has to be closed and the calibration source takes the place of the sample. A total of about  $130 \pm 10$  counts per minute should be registered with "Lo" as well as with "Hi" energy thresholds.

If no counts are registered, the detector or the electronics system may be at fault. A look with an oscilloscope at test point TP in back of the instrument should indicate which part is malfunctioning.

C. Test with a pulser

As an additional mode of testing, an input for a pulser is provided in the sensor head via a microdot connector. The output can be looked either at testing point TP or on the display. A 60 cycle pulser with a pulse-height of  $\sim 20$  mV at this point should operate the instrument.

D. Test with a paint sample

A paint sample with a known amount of lead is also provided to check periodically on any change in the calibration of the instruments with time.  $450 \pm 15$  c/min and  $175 \pm 15$  c/5 min should be registered with instrument SN/1 with "Lo" and "Hi" thresholds, respectively, and  $240 \pm 11$  c/min and  $87 \pm 7$  c/5 min with the SN/3 instrument.

If there is appreciable change from these responses the threshold levels R3 and R4 on the back of the instrument should be adjusted to obtain the predetermined counting rates.

At the same time the counting rate at the "Lo" position from pure elemental copper or zinc should be checked. This should not be more than 8-10 c/min.

VIII. Figure Captions

- Fig. 1. Picture of the Alpha Scattering Heavy Element Detector.
- Fig. 2. Diagram of the Sensor Head.
- Fig. 3. Logical diagram of the operation of the Alpha Scattering Heavy Element Detector instrument.
- Fig. 4. The electronic schematics and the physical layout of components for the preamplifier.
- Fig. 5. The electronic schematics and the physical layout of components for the postamplifier.
- Fig. 6. Block diagram of the electronics for the Alpha Scattering Heavy Element Detector.
- Fig. 7. The electronic schematics for the charger.
- Fig. 8. Calibration on curve for "Lo" threshold.
- Fig. 9. Calibration on curve for "Hi" threshold.

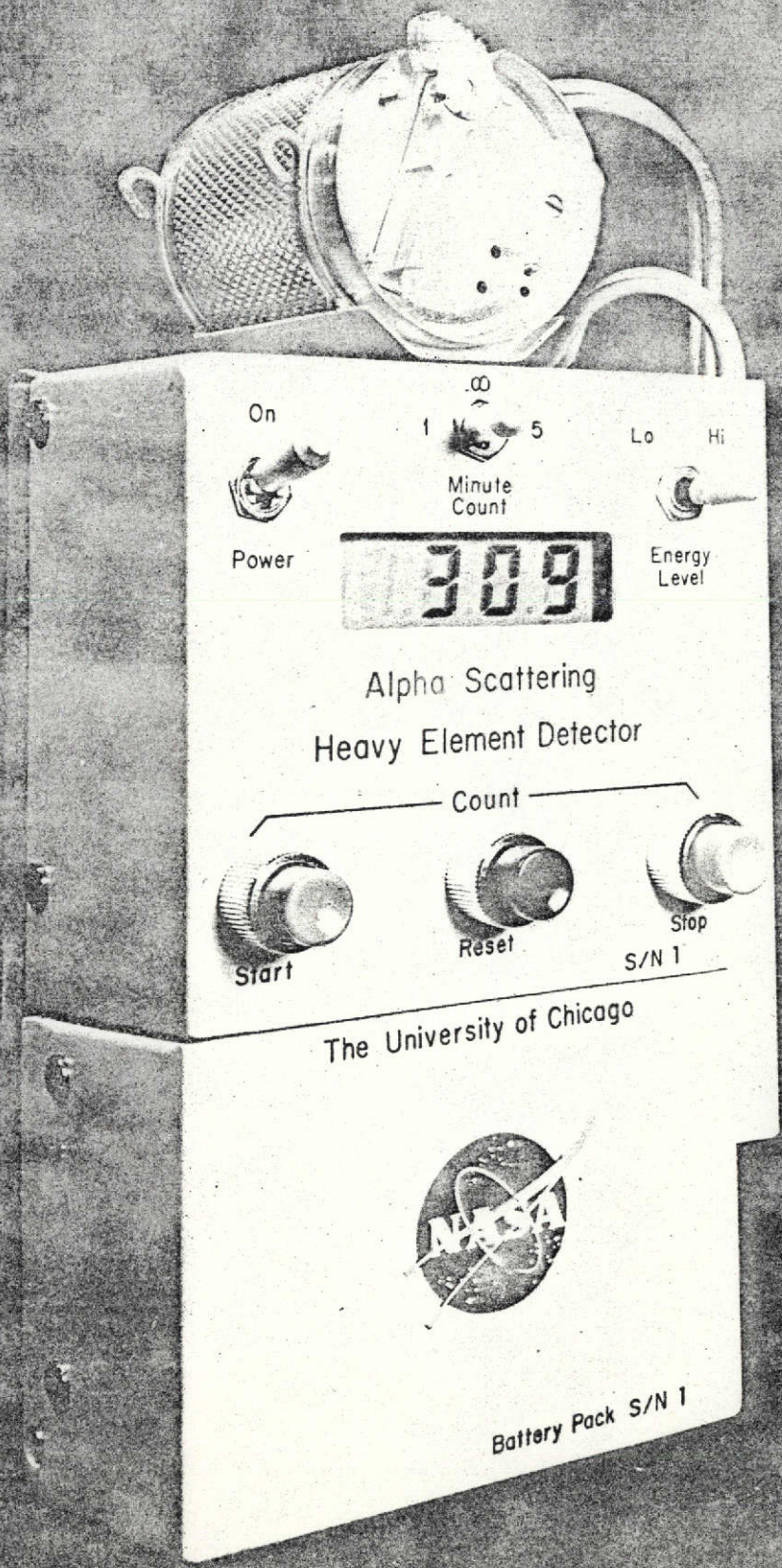

On

∞  
1 5

Lo Hi

Power

Minute  
Count

Energy  
Level

309

Alpha Scattering  
Heavy Element Detector

Count

Start

Reset

Stop

S/N 1

The University of Chicago



Battery Pack S/N 1

FIG-1



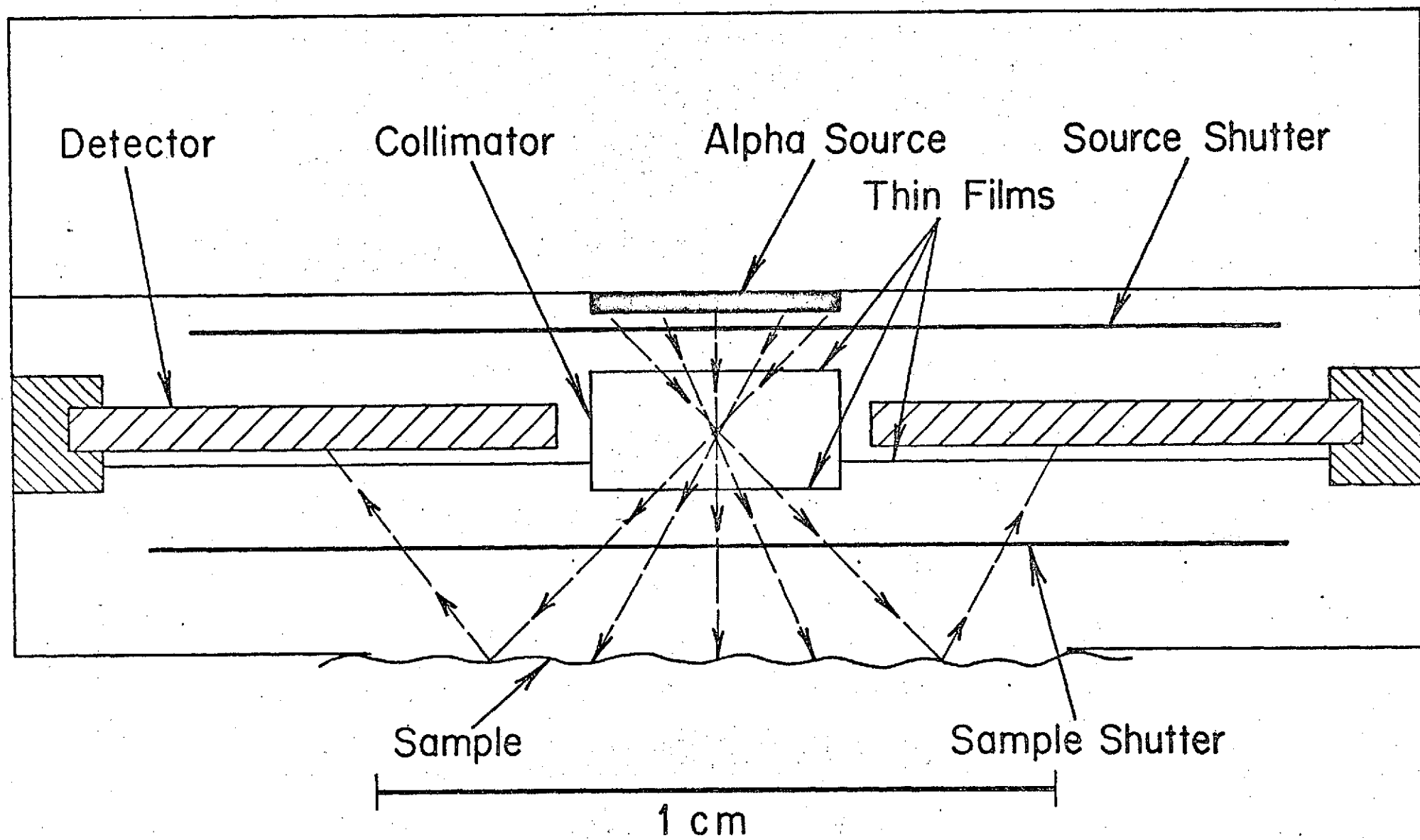
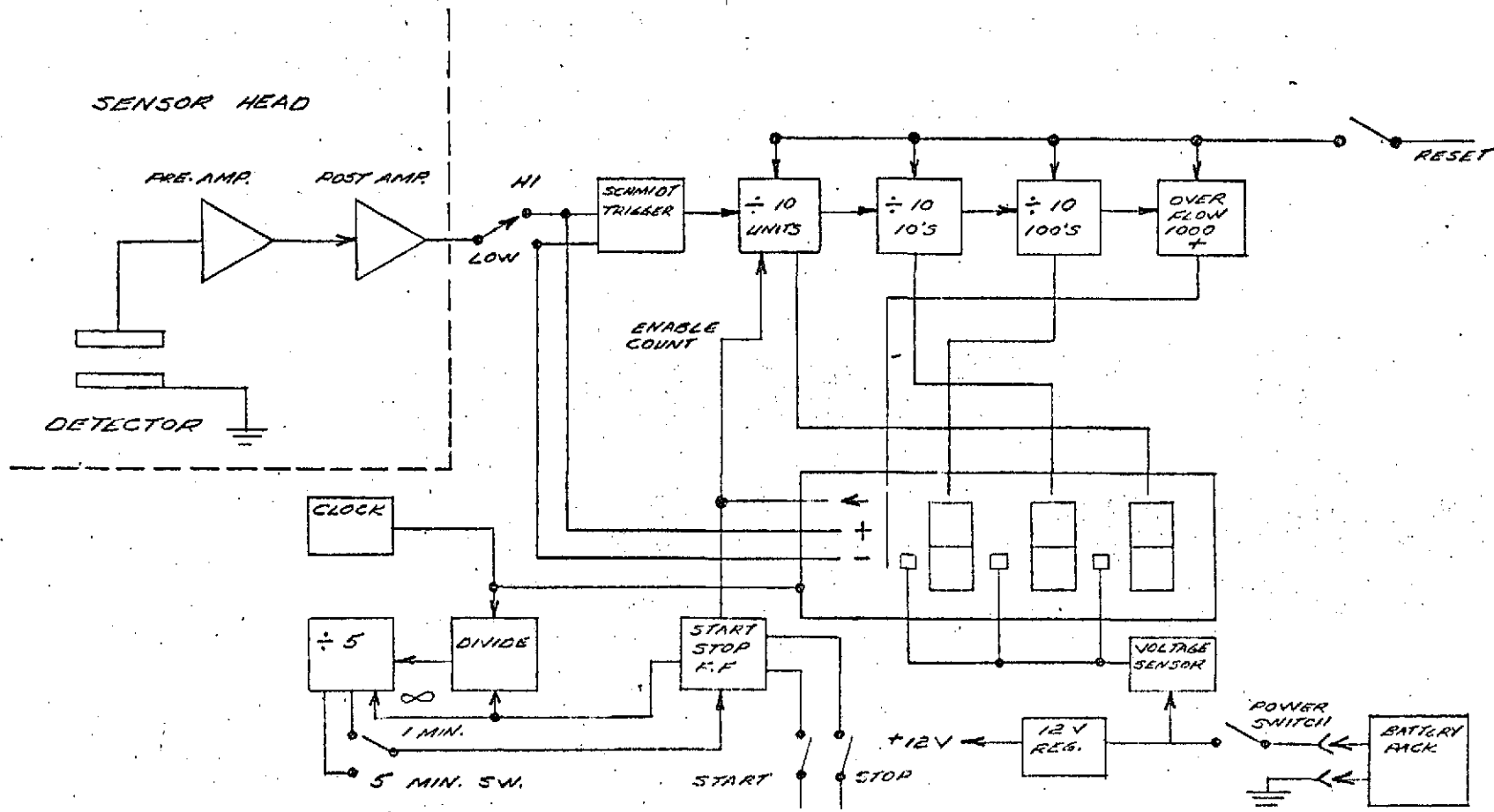

Fig.2



TOL'S ON OPEN DIM'S: DEC. ± .005 FRAC. ± 1/16 ANGLES ± 1/2°					MATERIAL		REQ'D	
REV. LET.	BY	CHK.	DATE	CHANGE	DESIGN.	DATE	TITLE ALPHA SCATTERING HEAVY ELEMENT DETECTOR LOGIC DIAGRAM	LABORATORY FOR ASTROPHYSICS AND SPACE RESEARCH OF THE ENRICO FERMI INSTITUTE THE UNIVERSITY OF CHICAGO
○					3-9-59			
○								
○								
○					APPROV.	DATE	PROJECT UGW SIZE B UGW NO.	REV. LET. ○
○					FINISH			
○					*This drawing, together with all information and techniques disclosed therein is the property of The University of Chicago and no use, disclosure, or reproduction of any part thereof may be made except by written authorization of The University of Chicago.*		SCALE USED ON ASSY NO.	

Fig. 3

IX. Appendix

1. "Heavy Elements in Surface Materials: Determination by Alpha Particle Scattering", by Thanasis E. Economou, Wayne A. Anderson, Edwin M. Blume and Anthony Turkevich, Science 181, 156 (1973).

Appendix 2.

Spectra of Cm-244 sources used on the Alpha Scattering  
Heavy Element Detectors SN/1 and SN/3.

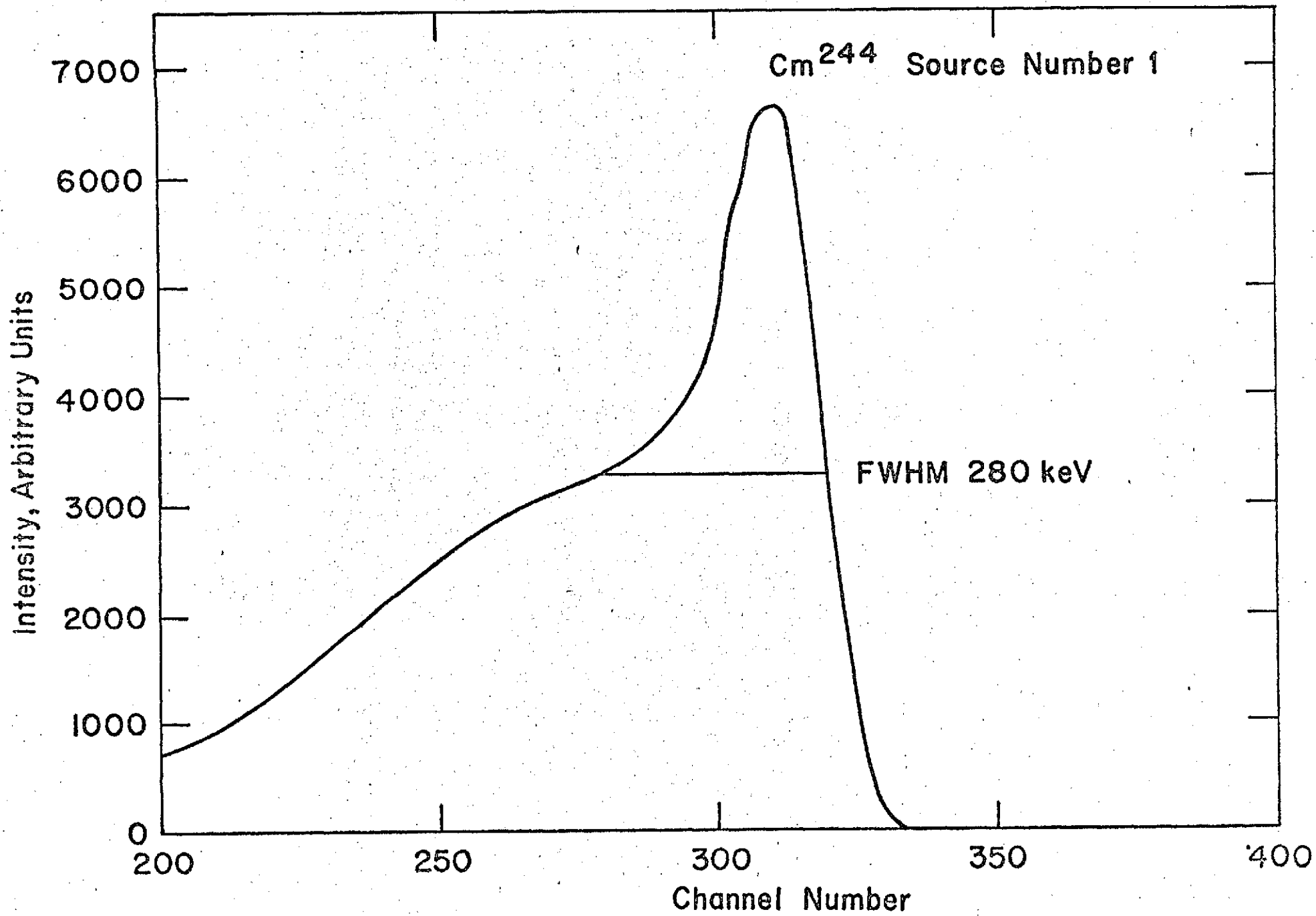

Cm<sup>244</sup> Source Number 3

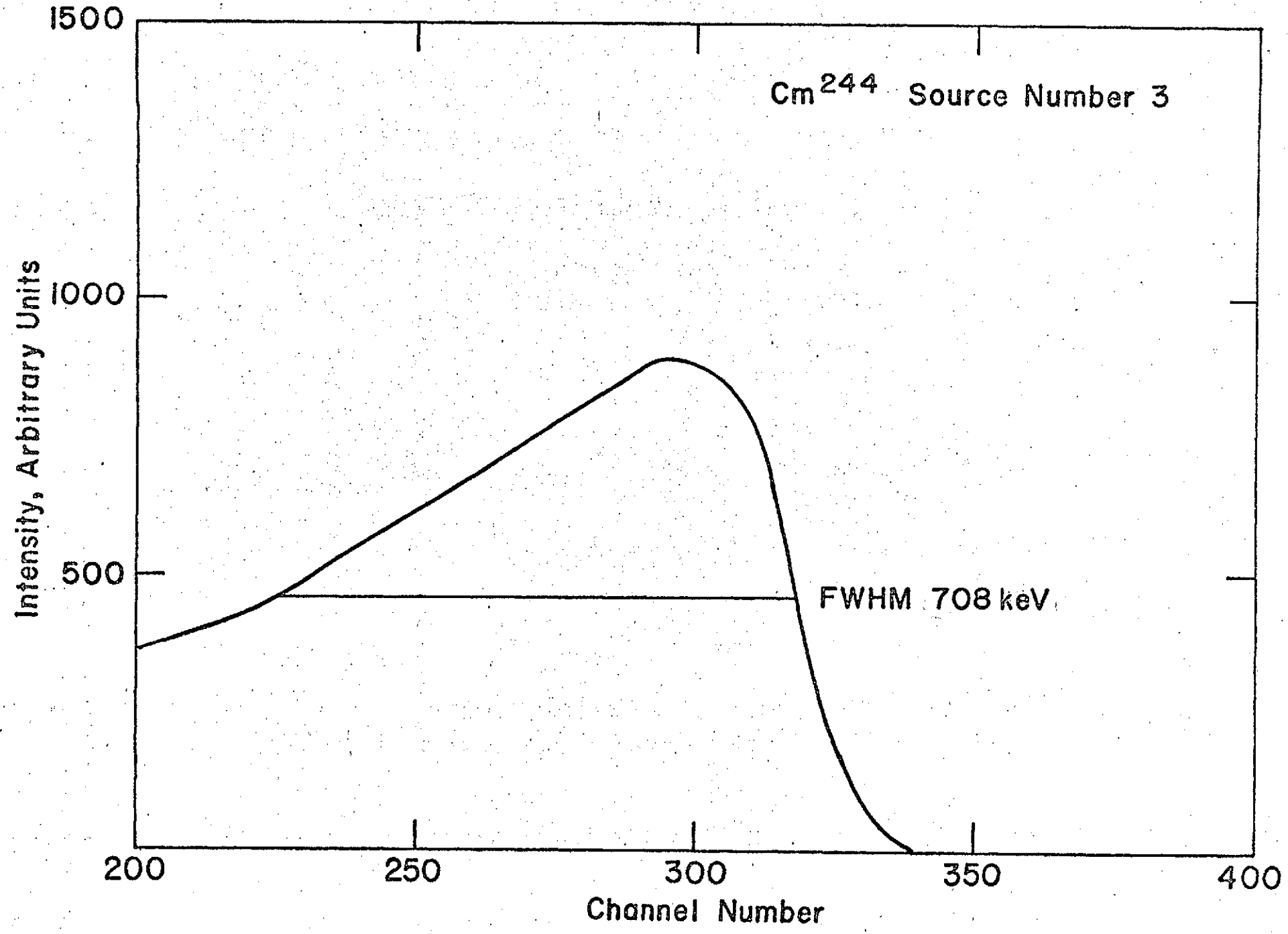

Appendix 3.

Electronic Schematics for the Alpha Scattering Heavy  
Element Detector.





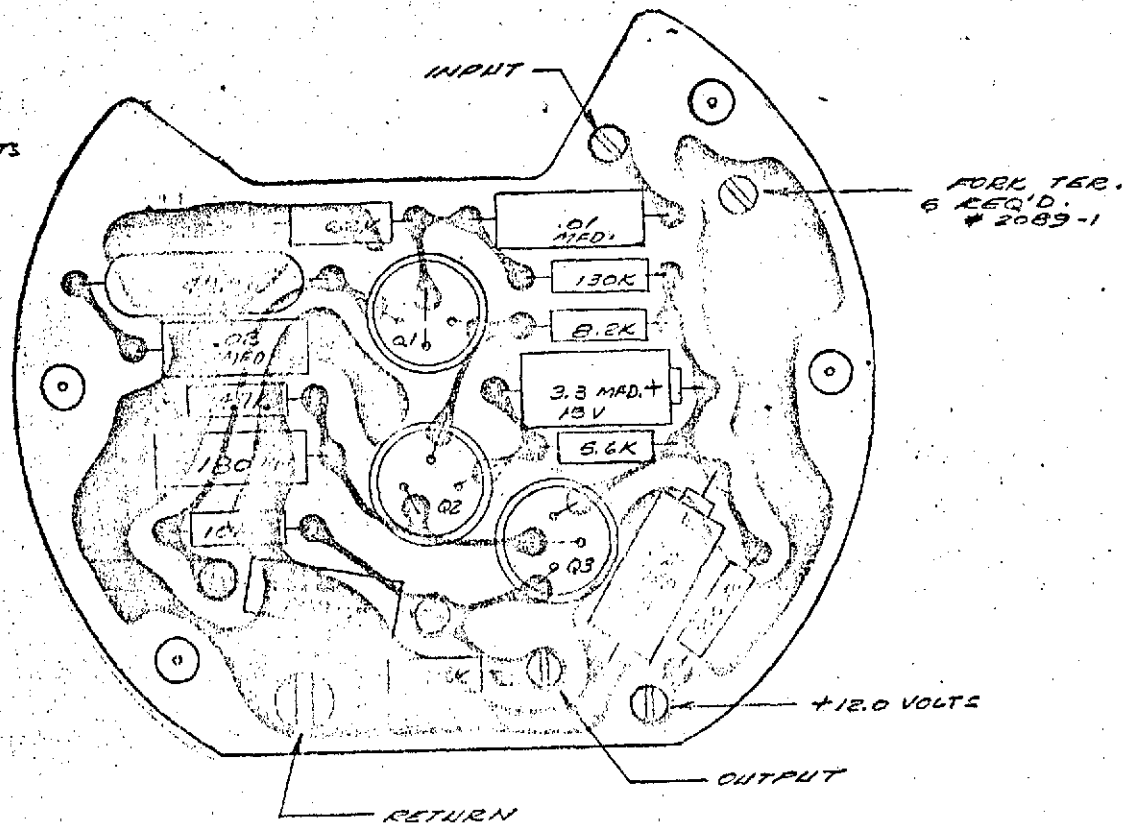
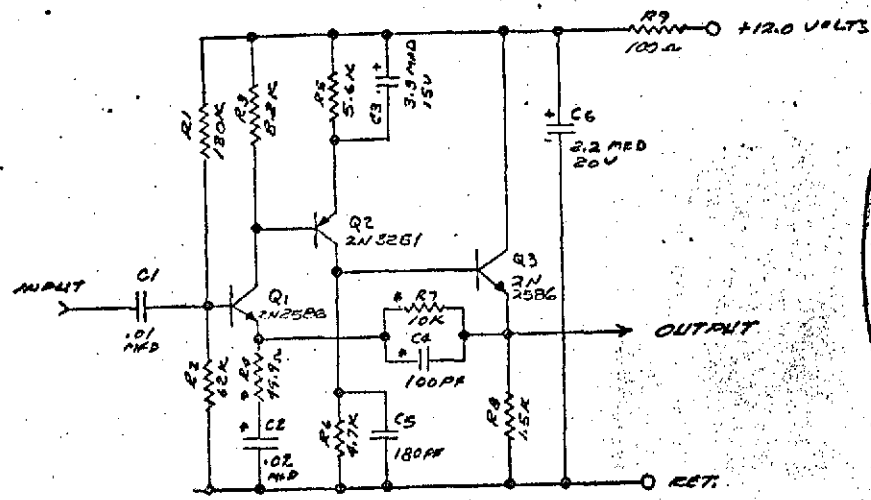

Q1 & Q3 - 2N2586 A7 @ -70°C  
 Q2 - 2N3251 B2 @ -70°C  
 \* PRECISION COMPONENTS

TOL'S ON OPEN DIM'S: DEC. ± .005 FRAC. ± 1/16 ANGLES ± 1°					MATERIAL 1/2 COPPER CLAD		REQ'D 1
DESIGN	DATE	TITLE					
CHK.	DATE	LP2, POST AMPLIFIER					
APPROV.	DATE	PROJECT					
FINISH		LP2					
"This drawing, together with all information and techniques disclosed therein is the property of The University of Chicago and no use, disclosure, or reproduction of any part thereof may be made without written authorization of The University of Chicago."		SCALE	DWG. SIZE	DWG. NO.	LABORATORY FOR ASTROPHYSICS AND SPACE RESEARCH OF THE ENRICO FERMI INSTITUTE THE UNIVERSITY OF CHICAGO		
		4:1	B	LP2	DWS OK AMT MU. REV 127. 1		

Fig.5

Page intentionally left blank

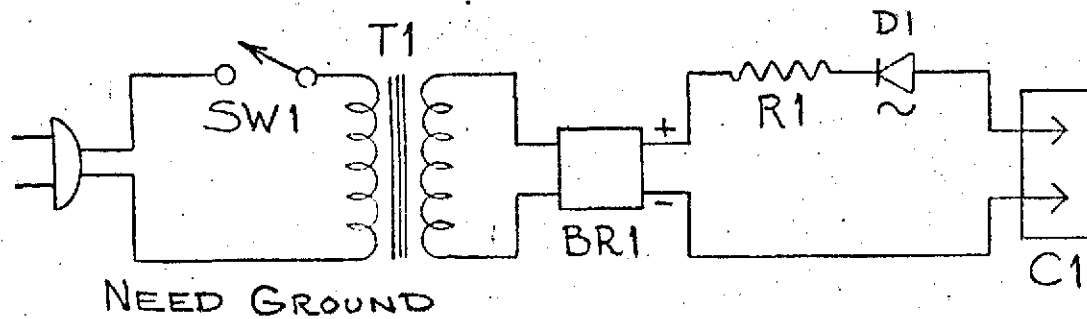

NEED GROUND

- T1 TRANSFORMER - TRIAD F-59X 60VOLT
- SW1 ALCO SWITCH MSTA-106D
- R1 DALE RESISTOR RM10 1000Ω 10 WATT
- D1 LED MONSANTO MV 5021
- BR1 BRIDGE RECTIFIER MOTOROLA MDA 942-6  
1.5 AMP 600V.
- C1 CONNECTOR WINCHESTER SM2P

OR EQUAL

||  
||  
||  
||

REPRODUCTION OF ORIGINAL PAGE IS POOR

TOL'S ON OPEN DIM'S: DEC. ± .005 FRAC. ± 1/64 ANGLES ± 1/2°

MAT'L

REQ'D

REV. LET.	BY	CHK.	DATE	CHANGE
○				
○				
○				
○				
○				
○				

DESIGN. W.A.	DATE
CHK. MLW	DATE 5/30/74
APPROV.	DATE
FINISH	

TITLE  
L.P.D.  
BATTERY CHARGER

"This drawing, together with all information and techniques disclosed thereon is the property of The University of Chicago and no use, disclosures, or reproduction of any part thereof may be made except by written authorization of The University of Chicago".

PROJECT  
L.P.D.  
SCALE

LABORATORY FOR ASTROPHYSICS AND SPACE RESEARCH OF THE ENRICO FERMI INSTITUTE  
THE UNIVERSITY OF CHICAGO

DWG. SIZE A	DWG. NO.
USED ON ASS'Y NO.	REV. LET. ○

Fig.7

Appendix 4.

Calibration Curves

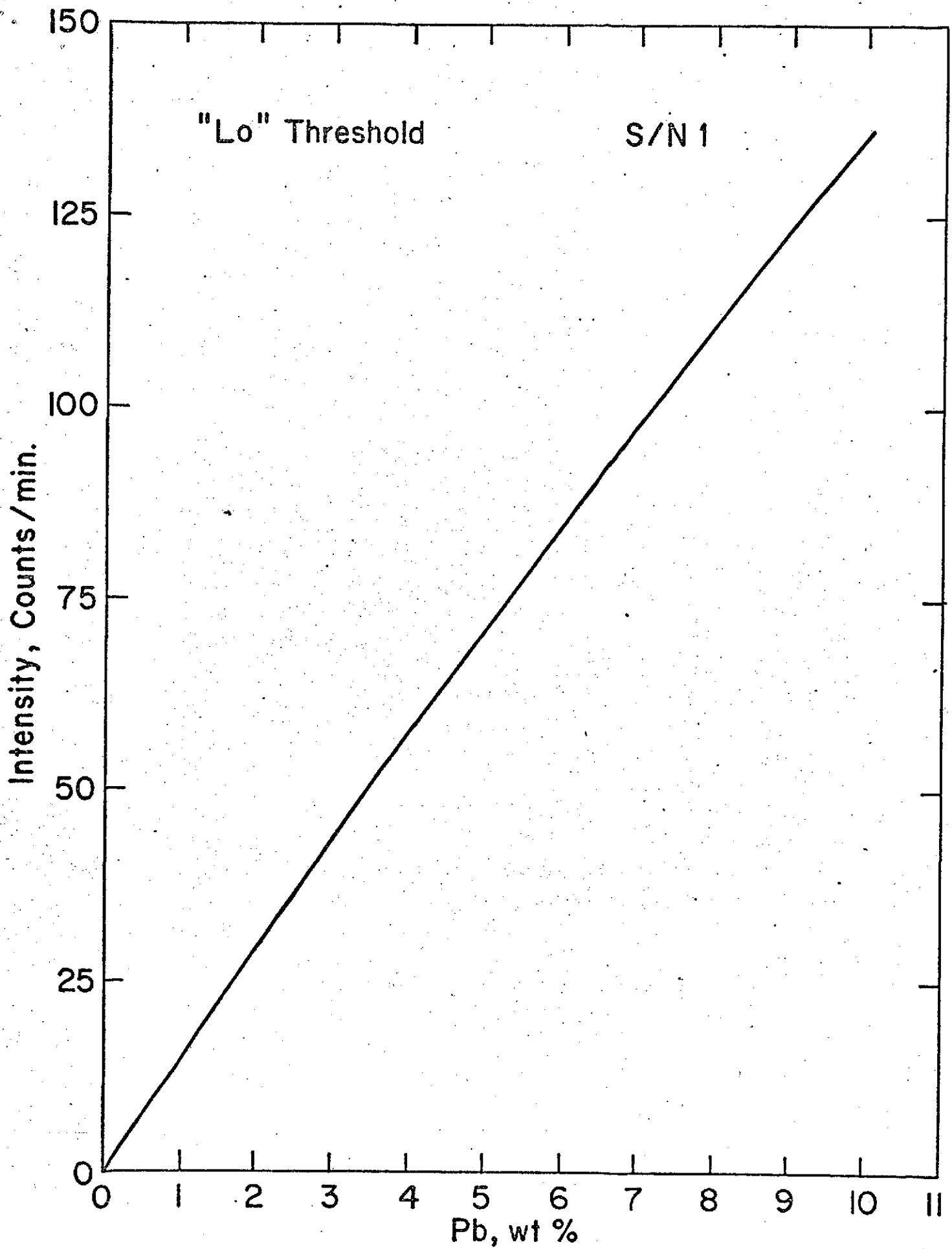

Fig.8

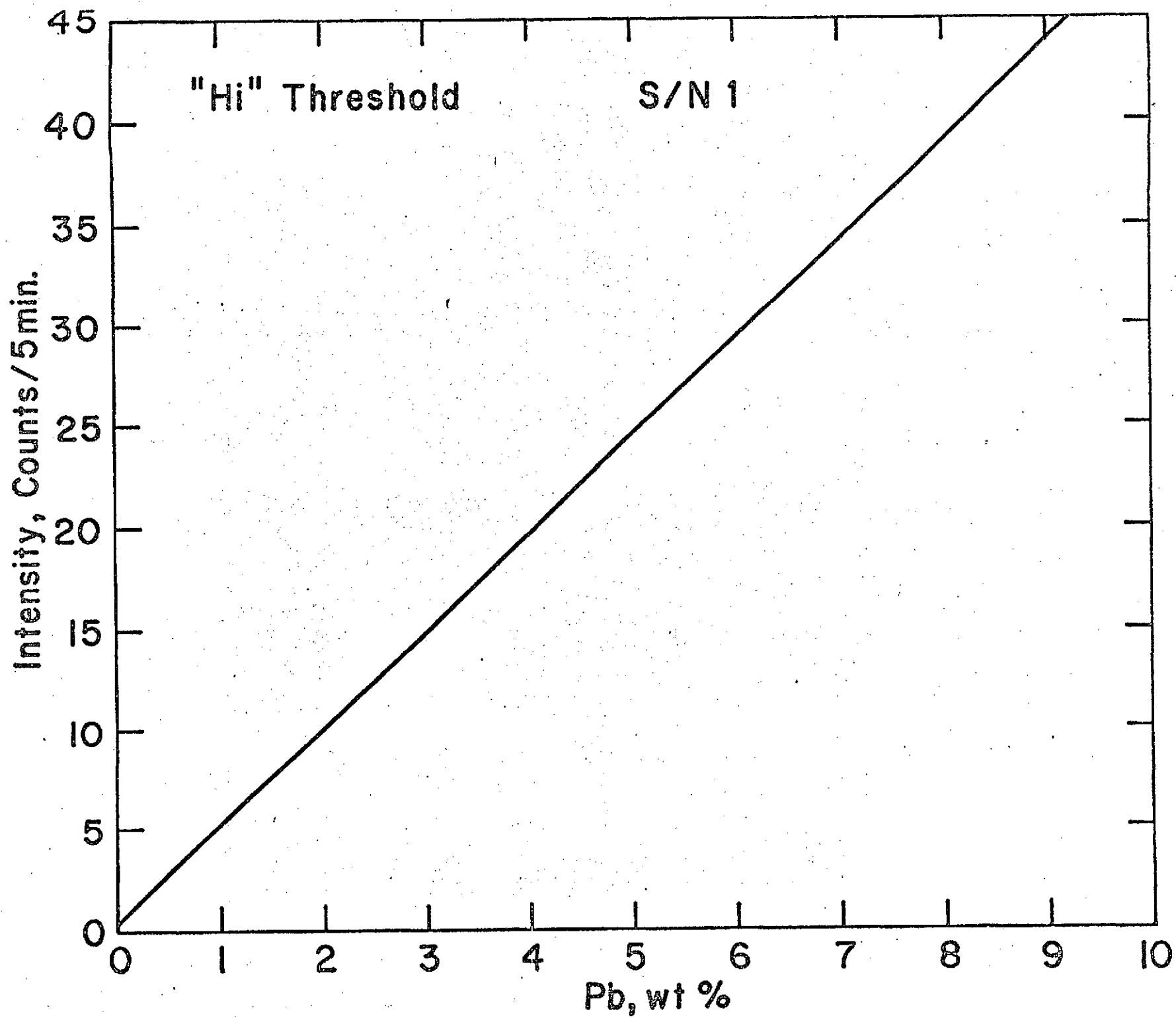

Fig.9

Appendix 5.

Mechanical Drawings