

NASA SP-5907 (03)

**TECHNOLOGY UTILIZATION**

**ELECTRONIC TEST INSTRUMENTATION  
AND TECHNIQUES**

**A COMPILATION**



**NATIONAL AERONAUTICS AND SPACE ADMINISTRATION**

# Foreword

The National Aeronautics and Space Administration and Atomic Energy Commission have established a Technology Utilization Program for the dissemination of information on technological developments which have potential utility outside the aerospace and nuclear communities. By encouraging multiple application of the results of their research and development, NASA and AEC earn for the public an increased return on the investment in aerospace and nuclear research and development programs.

This document is one of a series intended to furnish such information. The Compilation is divided into three sections that reflect the more important uses of such test equipment and techniques, as they have been employed in the space research and development programs, both in-house and by NASA and AEC contractors.

The first section introduces a group of modifications and adaptations that have been found useful to either enlarge the scope of usefulness or divert from their basic uses to alternate applications, a selection of available devices and established techniques. Section two presents items that have been of benefit to professional personnel in the enlargement and improvement of quality control capabilities. The third section covers a number of items that have simplified or made more accurate the very important function of calibration, upon which much depends when measurements or analyses are involved.

Additional technical information on individual devices and techniques can be requested by circling the appropriate number on the Reader Service Card included in this Compilation.

The latest patent information available at the final preparation of this Compilation is presented on the page following the last article in the text. For those innovations on which NASA and AEC have decided not to apply for a patent, a Patent Statement is not included. Potential users of items described herein should consult the cognizant organization for updated patent information at that time.

We appreciate comment by readers and welcome hearing about the relevance and utility of the information in this Compilation.

Jeffrey T. Hamilton, *Director*  
*Technology Utilization Office*  
*National Aeronautics and Space Administration*

NOTICE • This document was prepared under the sponsorship of the National Aeronautics and Space Administration. Neither the United States Government nor any person acting on behalf of the United States Government assumes any liability resulting from the use of the information contained in this document, or warrants that such use will be free from privately owned rights.

---

For sale by the National Technical Information Service, Springfield, Virginia 22151. \$1.00

# Contents

	Page
<b>SECTION 1. MODIFICATIONS AND ADAPTATIONS</b>	
Single Point Test Adapter .....	1
Function Generator Adapter .....	2
Potentiometer Drive Adapter for Instrument Control Knobs .....	3
Advances in Electrometer Vacuum Tube Design .....	4
Adapter Provides Low Frequency FM Signal at Low Voltage with Variable Deviation .....	4
Electron Tube Assembly Generates Video Signals for Alphanumeric Displays: A Concept .....	5
Wattmeter Adaptation to Increase Accuracy .....	6
Circuit Analyzer Adapted to Function as an Overvoltage Detector .....	7
Dual Trace Adapter for a Small Portable Oscilloscope: A Concept .....	8
<b>SECTION 2. QUALITY CONTROL DEVICES AND TECHNIQUES</b>	
Spark Transducer Generates Ultrasonic Energy .....	9
Technique to Accurately Measure Isolation in Waveguide Circulators .....	10
Thermal Flux Simulation .....	10
Transistor Test Heat Chamber .....	11
Tester for Resonant Frequencies of Ferrite Devices .....	12
Nonlinear Resistance Voltage/ Current Relationships Determined by Measuring Harmonics .....	13
Improved Analysis of Coil and Motor Winding Vibration Tests: A Concept .....	14
Magnetic Field Mapper .....	15
Hot Resistance Measurements Used to Predict Fuse-Blow Current Levels .....	16
<b>SECTION 3. CALIBRATION DEVICES AND TECHNIQUES</b>	
Calibration Technique for Electromagnetic Flowmeters .....	17
"Do It Yourself" Shock Spectrum Analyzer .....	18
Continuous Source of Vacuum Ultraviolet Below 500Å .....	19
A Compact Rotary Vane Attenuator .....	20
Flaw Simulator for Eddy Current Probe Calibration .....	21
An Improved Atomic Hydrogen Frequency and Time Standard .....	22
<b>PATENT INFORMATION</b> .....	23

# Section 1. Modifications and Adaptations

## SINGLE POINT TEST ADAPTER

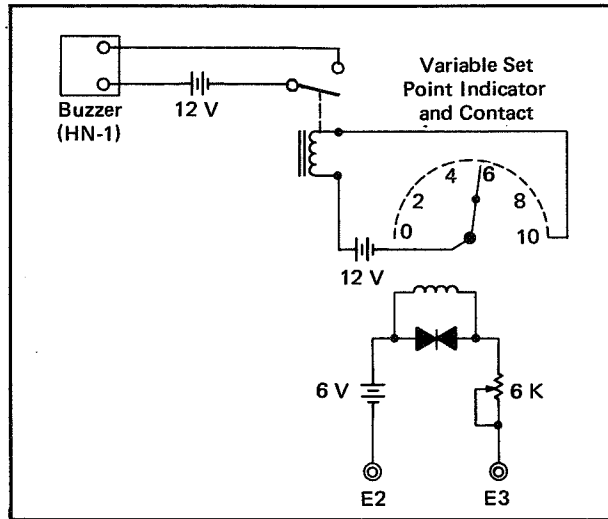

Single Point Test Adapter

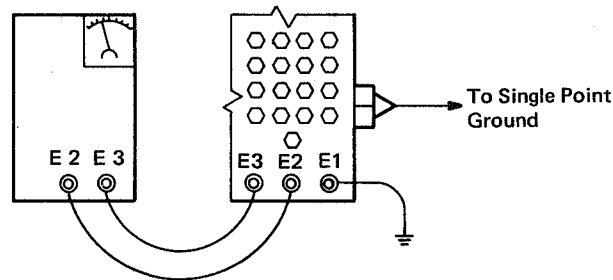

This test adapter is essentially an automatic warning device that detects short circuits during component and systems installation. The prior method was to run short circuit tests of the entire single point ground system after all installations were completed. This involved an extensive and complex system of electrical circuitry and appreciable troubleshooting time.

This single point test adapter unit operates in conjunction with a switching array (see figure) termed Systems Measuring Device which places all monitored wiring on an internal common bus. The test adapter is also connected to this bus, and to the system cabinet structure. When a short circuit occurs

as a component or subassembly is being installed, the meter needle swings toward the variable set point indicator. As the two indicators meet, they magnetically lock and complete a circuit that energizes buzzer HN-1 to give the indication of the short circuit.

Source: P. Chambers and H. F. Smith of Rockwell International Corp. under contract to Marshall Space Flight Center (MFS-14629)

Circle 1 on Reader Service Card.

### FUNCTION GENERATOR ADAPTER

This device converts a standard signal generator to a pulse generator that can be regulated to deliver a single cycle to the load at frequencies between 20 Hz and 10 kHz while maintaining a reference potential of 0.0 V. The adapter is designed to gate the signal generator so the output is connected to the load for one cycle out of every eight (8) cycles as shown here.

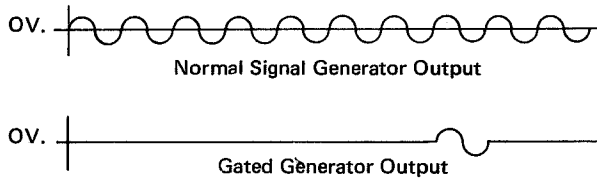

The schematic shows the composition of the adapter as it is operated. The +12 volts and -11 volts are obtained from regulated power supplies. Q1, along with D1 and R1, form a voltage regulator circuit to maintain the emitters of Q3 and Q4 at a potential of -7.5 volts. Component Q2, along with

R2, D2, and R3, form a variable voltage regulator to supply a minimum of +0.7 volts, and a maximum of +9.0 volts to the circuit. Q3 and Q4, with R5, R6, R7, and R9, convert an incoming pulse (0 ≈ -10.0 volts; 1 ≈ -3.0 volts) to the voltage levels required by Q5 (0 ≈ -7.5 volts; 1 = +0.7 volts min., +9.0 volts max., depending on adjustment of R3). Q5 is an N-channel junction field-effect transistor that operates in the depletion mode.

The gate of Q5 is normally held at -7.5 V by Q4 being on. An incoming pulse turns Q3 on, and Q4 turns off, thus applying the positive voltage to the gate of Q5, maintaining Q5 on for the duration of the pulse. Q5 now acts as a single-pole, single-throw switch in series with the signal generator.

Source: E. W. Hart of  
The Boeing Company  
under contract to  
Marshall Space Flight Center  
(MFS-15084)

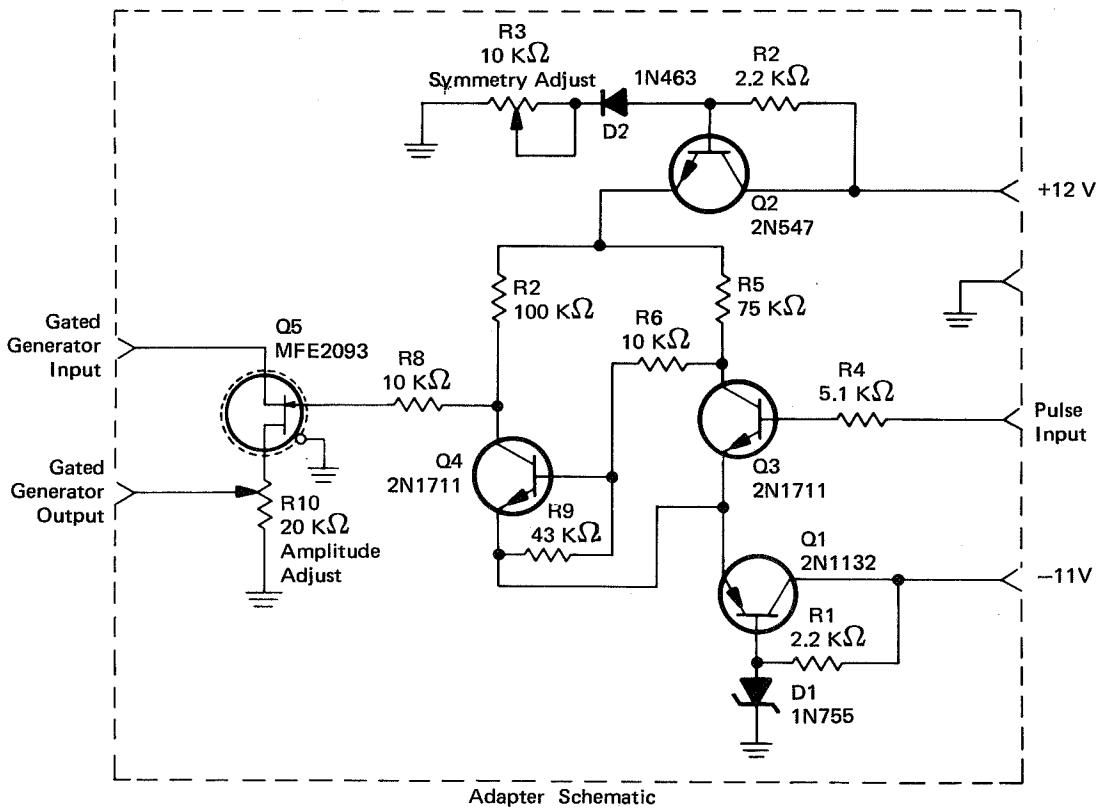

Adapter Schematic

Circle 2 on Reader Service Card.

## POTENTIOMETER DRIVE ADAPTER FOR INSTRUMENT CONTROL KNOBS

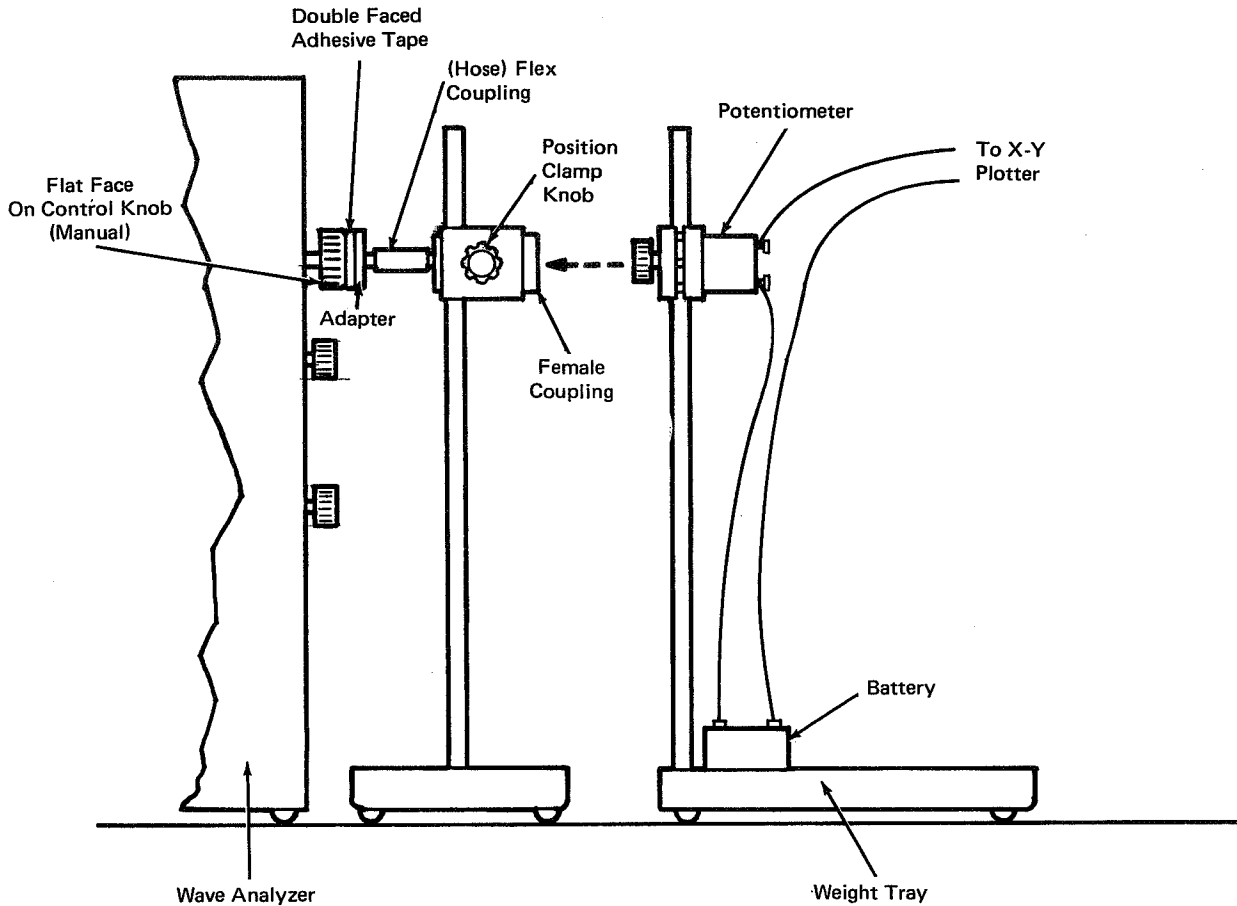

This potentiometer drive adapter is a simple, inexpensive, and straightforward way to automatically plot a direct graph of the output of an electronic wave analyzer. As shown in the figure, the potentiometer that is to drive an X-Y plotter is mounted on a free-moving platform that also contains the battery to power both potentiometer and plotter. A section of double-faced adhesive tape interfaces with the flat surface of the wave analyzer control knob and the drive adapter, which is also mounted on a free-moving platform. A flexible hose-type coupling attaches the drive adapter to a female coupling designed to receive the potentiometer male coupling. As the manual control knob on the

wave analyzer is turned, the X-Y plotter will automatically record its position on a graph.

While simple in design, this adapter will relieve test personnel from a considerable amount of hand-entered recording of wave analyzer knob positions. With relatively simple modification, this adapter could be used to automatically record control knob positions of a wide variety of laboratory equipment.

Source: F. H. Stuckenberg of Rockwell International Corp. under contract to Marshall Space Flight Center (MFS-16866)

Circle 3 on Reader Service Card.

## ADVANCES IN ELECTROMETER VACUUM TUBE DESIGN

Electrometers have been used in industrial and laboratory applications for detecting very low signals in the pico-volt ( $10^{-12}$ ) range. In the past, the vacuum tubes used to drive these devices required more current than desirable and were subject to damage and failure through shock and vibration. As a result, design advances in both the construction and performance of these tubes have been required.

A single-ended, miniature-cathode tube with a relatively low grid current level was constructed. Adequate cathode temperature at relatively low heater power drain is provided by designing the supporting spacers to provide a square cathode hole. By mounting a round cathode in a square hole, the four-point contact between cathode and spacers combines minimum cathode cooling with rugged construction. High insulation resistance between tube elements is achieved by coating the spacers with a coarse-grained fused aluminum oxide.

This tube exhibits very stable performance and operates with a grid current level below  $3.0 \times 10^{-14}$  amps. Samples exposed to temperatures of  $150^\circ \text{C}$  for 100 hours showed little change in characteristics, making the tube applicable to future low energy radiation investigations where thermal sterilization of the tube is probable.

To achieve a satisfactory metal-ceramic filamentary subminiature electrometer tube, a leak-tight subminiature ceramic stem (insulator) assembly was fabricated. The ceramic stem, made of 96% alumina, was metal-

ized with lithium-molybdate followed by nickel plating. The metalized and plated ceramic-nickel leads and nickel sealing ring were then brazed together into a leak-tight assembly.

Assembling the mount and bonding the tube elements and a metal sealing ring to a top ceramic spacer without damaging the filament was accomplished by the following method. The metal sealing ring used at the top of the mount was modified by the addition of a window to allow the entrance of a welding tip so that the top filament could be welded after the sealing ring and unit were bonded together. The filament was added and the unit was attached to the stem assembly with flexible leads. This assembly was inserted into the nickel sleeve that forms the metal envelope and was heliarc-welded at the top and bottom of the mount assembly.

The following documentation may be obtained from:  
National Technical Information Service  
Springfield, Virginia 22151  
Single document price \$3.00  
(or microfiche \$0.95)

### Reference:

NASA-CR-96797 (N70-75458), Advanced Electrometer Vacuum Tubes

Source: Raytheon Company  
under contract to  
Goddard Space Flight Center  
(GSC-10729, 10730, 10731)

## ADAPTER PROVIDES LOW FREQUENCY FM SIGNAL AT LOW VOLTAGE WITH VARIABLE DEVIATION

This relatively low-cost device can be used with standard signal generating units to introduce FM signals of very low frequency and voltage while permitting variation of modulation and deviation needed to calibrate frequency deviation (drift) meters.

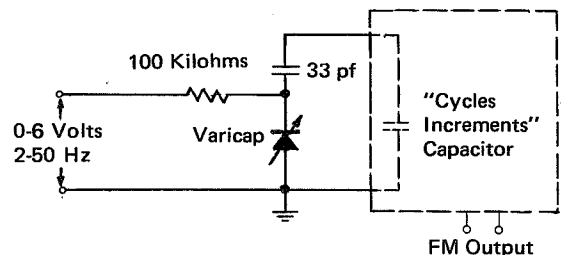

Figure 1. Method For Generating A Low Frequency FM Signal

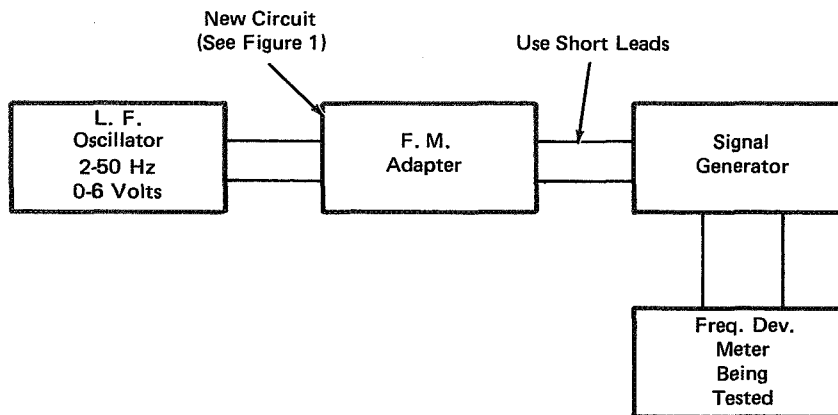

Figure 2. Adapter Being Used In Calibration Circuit

The adapter is used with a low frequency oscillator that supplies an input at any desired frequency from 2 to 50 Hz at voltages from 0 to 6. The adapter connects the oscillator output to pure capacitance that changes in value at a repetition rate dependent upon signal amplitude. Figure 1 shows the adapter with its variable capacitance mentioned above, and Figure 2 shows the adapter in circuitry designed to

use its signal-amplitude dependence to calibrate a frequency deviation meter.

Source: R. E. Calhoun of  
Rockwell International Corp.  
under contract to  
Johnson Space Center  
(MSC-13027)

*No further documentation is available.*

**ELECTRON TUBE ASSEMBLY GENERATES VIDEO SIGNALS FOR ALPHANUMERIC DISPLAYS: A CONCEPT**

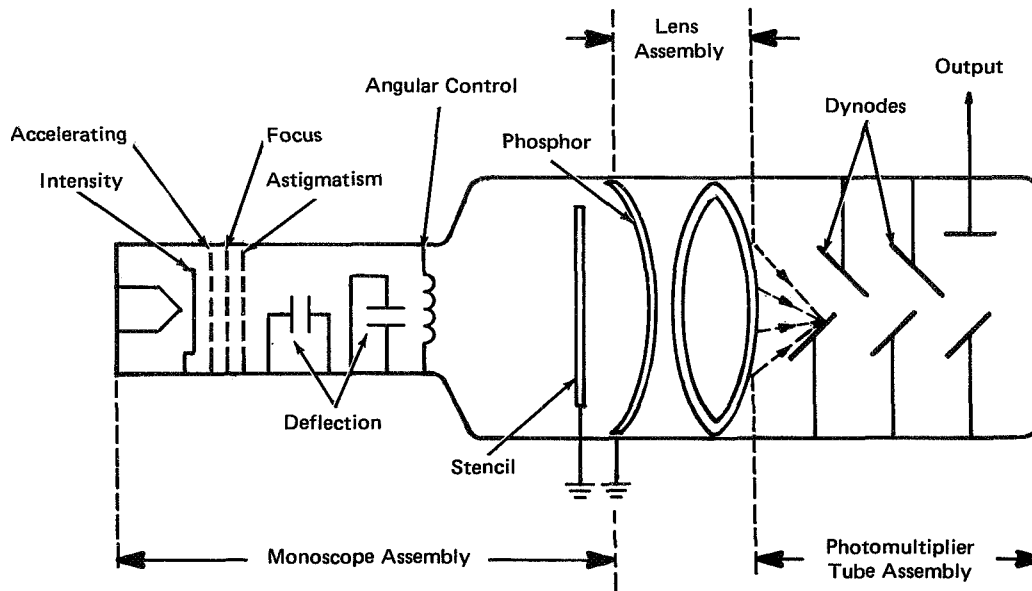



This concept would improve on the performance of a conventional monoscope or "stencil" tube. Most systems used to display alphanumeric characters as output data, employ a monoscope tube assembly as a signal source to modulate the beam of a conventional cathode ray tube (CRT) which is used as the display screen. The monoscope tube includes an aluminum stencil with the derived character set cut into it. The input signal positions the electron beam over the desired character cutout. The beam is scanned across the character cutout at a linear horizontal rate and in a vertical sinewave fashion. Very high amplification of the secondary emission electron signals is required and the tube performance is degraded by an extremely poor signal-to-noise ratio.

The device proposed here (see figure) would combine the general features of the monoscope tube with the inherently high output capability of a photomultiplier tube. This monoscope/photomulti-

plier (MPM) tube could be used with conventional circuitry to modulate the output display CRT beam. The beam of the monoscope portion of the MPM tube, after passing through the appropriate character in the stencil, would impinge on a low persistency (i.e., high-frequency response) phosphor screen. Output of the phosphor screen would then be focused onto the dynodes of the photomultiplier portion of the MPM tube. Following normal photomultiplier action, the amplified signal would be extracted from the MPM tube and processed conventionally for modulation of the CRT output display.

Source: J. M. Gurneck of  
Rockwell International Corp.  
under contract to  
Marshall Space Flight Center  
(MFS-16694)

Circle 4 on Reader Service Card.

### WATTMETER ADAPTATION TO INCREASE ACCURACY

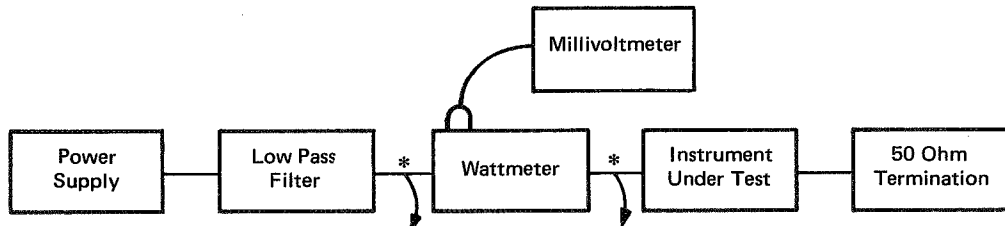

\*Meter Shunts (Female-to-Female "N" Coupler)

An inexpensive RF wattmeter has been so adapted that it is possible to perform measurements that would normally require more expensive, sophisticated equipment and more elaborate techniques. This adaptation, including the basic RF wattmeter, costs about \$200 versus the approximate \$2,000 or more for a conventional system that would achieve the same accuracy and resolution.

In this adaptation, a commercially available RF wattmeter is fitted with external terminals to which shielded leads are attached to form a shunt across the internal meter. This adaptation, enables the RF wattmeter to cover a wide range of measurements by using the appropriate combination of interchangeable elements. The function of these elements is to convert the high frequency input to direct current. To avoid introduction of possible error, the complete range of

elements to be used with a given meter must be calibrated with and used exclusively with that meter.

A 0.1% high impedance millivoltmeter is used externally to read the output. The adaptation results in measurements accurate within 3.0% and a calibration cycle that is safely extended from a 1- to 3-month interval to a 4- to 6-month interval. This accuracy permits use of the adapted instrument to calibrate standard RF wattmeters routinely in use, which require only a 5.0% certification.

Source: R. W. Polen and K. G. Flanding of  
The Boeing Company  
under contract to  
Marshall Space Flight Center  
(MFS-13955)

Circle 5 on Reader Service Card.

CIRCUIT ANALYZER ADAPTED TO FUNCTION AS AN OVERVOLTAGE DETECTOR

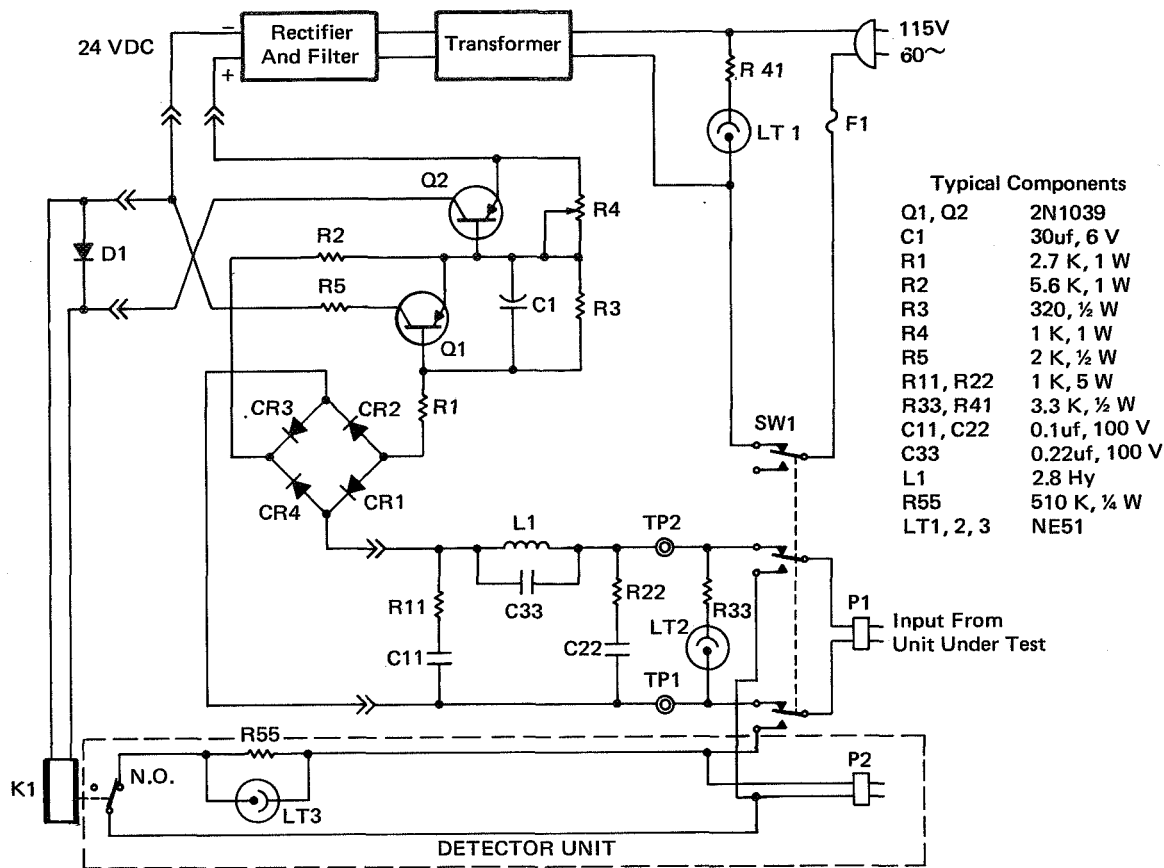

The function of this adaptation is to add, with relatively simple circuitry, the capability of detecting overvoltages from a unit under test that could, if permitted to continue, cause damage to expensive testing equipment. The testing equipment involved is designed to detect short circuits and insulation breakdown in sophisticated electronics, but is not designed to withstand voltages above discrete thresholds that are clearly defined by application.

There is no need to modify the test equipment to make use of this adaptation, which may be switched into and out of the test setup during normal test operation. Input (see figure) from the unit under test is filtered through the pi-type filter consisting of R11 and R22; C11, C22, and C33; and L1 (see figure). The full wave rectifier, CR1-through-CR4, rectifies the input signal and feeds it to forward bias Q1 through R1, R2, and R3, with C1 filtering the rectifier ripple output.

With SW1 connecting the adapter unit to the test equipment and detector unit, emitter follower Q1 is biased on, thus raising the forward bias level of transistor Q2 from ground potential towards -24 Vdc. Potentiometer R4 is set to inhibit the conduction of Q2 until the predetermined level of signal from the unit under test has been exceeded. At this point, Q2 conducts and closes normally-open K1 which closes the circuit of the detector unit to light LT3 and alert the operator to the overvoltage.

Source: T. Angello and K. Gregory of Grumman Aircraft Engineering Corp. under contract to Johnson Space Center (MSC-12208)

No further documentation is available.

## DUAL TRACE ADAPTER FOR A SMALL PORTABLE OSCILLOSCOPE: A CONCEPT

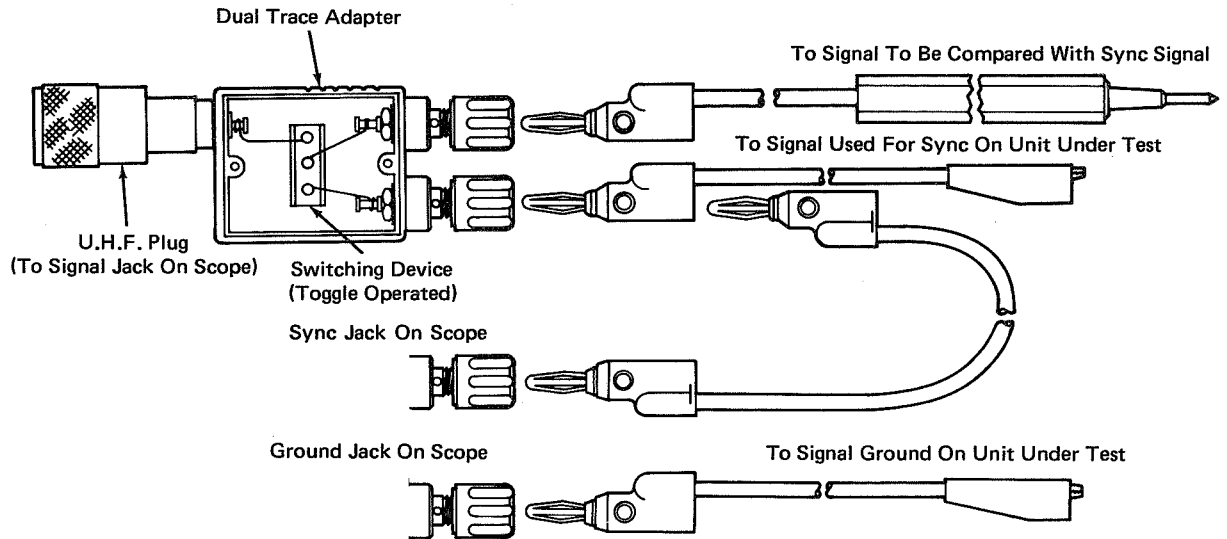

In order to facilitate the use of a small portable oscilloscope (scope) in synchronizing a test sample signal with a comparison signal, a dual trace adapter operates by switching the two signals into the scope alternately until synchronism is achieved.

Prior art consisted of probing each signal separately while making notes of each individual signal while adjustments were being made, until sync was finally achieved.

The dual trace adapter is used to monitor two signals for comparison although the scope has only one signal input (see figure). This is done by using one input signal to the adapter as a sync signal for the

scope, with a second input signal to the adapter only. The two input signals are compared on the scope by switching (toggle switch not shown) between them while adjustments are made to the unit under test until the signal traces on the scope coincide.

Source: D. D. Burt of  
Rockwell International Corp.  
under contract to  
Marshall Space Flight Center  
(MFS-14630)

*Circle 6 on Reader Service Card.*

## Section 2. Quality Control Devices and Techniques

### SPARK TRANSDUCER GENERATES ULTRASONIC ENERGY

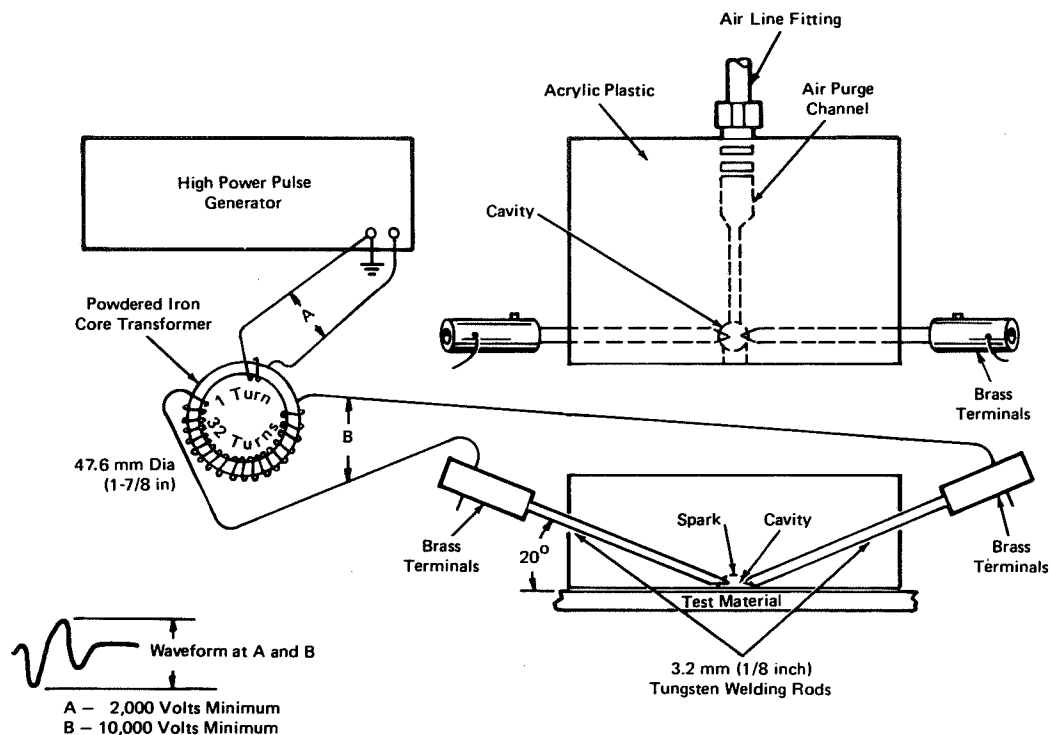

A spark transducer generates ultrasonic energy in a pulsed mode. It is used in nondestructive tests and quality control of laminated materials or composites, both metallic and nonmetallic. The device has certain advantages over other ultrasonic transducers, such as crystal oscillators, those types that make use of oscillatory magnetic fields, and pulsed lasers. The latter devices suffer from such limitations as couplant interference (crystal devices), low frequencies (magnetic field devices), or low pulse rates (laser devices).

In operation of the spark transducer (see figure), 2,000 V peak-to-peak pulses are applied to the transformer, which raises the pulses to 10,000 V peak-to-peak, the minimum level required to achieve sparking. Output of the transformer is applied to two sharp-pointed tungsten welding rods mounted in brass, sleeve-type terminals. The rods are supported in a nonconductive block of acrylic plastic. A tip gap and a tip-to-surface distance of approximately 0.05

in. has been found to work efficiently. The gap between the electrodes must not exceed the space useful to the available voltage, while, if too small, insufficient ultrasonic energy will be produced. Additionally, the ultrasonic energy is inversely proportional to the tip-to-surface distance, which, if too small, will create instability, especially with metal materials. The angle of the electrodes with respect to the test surface is not critical, angles of 20° to 30° having been used successfully.

Provision has been made for an air purge through a channel in a similar acrylic plastic block to clear ionization products from a hemispherical cavity to achieve more stable sparking.

Source: J. M. Hoop  
Marshall Space Flight Center  
(MFS-21233)

Circle 7 on Reader Service Card.

## TECHNIQUE TO ACCURATELY MEASURE ISOLATION IN WAVEGUIDE CIRCULATORS

Many three port circulators have previously been measured to have extremely high isolation over very narrow bandwidths. Isolation in excess of 50 dB has been reported. It has been realized that while these results represent an accurate measurement of the power ratios at the two ports in question, these ratios result from contributions other than the circulator isolation. The other most significant contribution results from the power reflected by the termination used at the non-isolated port. When these two contributions are of the same approximate magnitude and opposite phase, a cancellation occurs, resulting in very high apparent isolation. Therefore, this measured isolation can be very different from the true isolation, and can also be very dependent upon the vswr (voltage standing wave ratio) of the termination used at the non-isolated port.

A method has been developed to accurately determine isolation of a three-port circulator. This method may be implemented with equipment which measures only amplitude of transmission through a terminated

circulator. A system which, in addition, measures phase shift, simplified the measurement considerably. The advent of computer-controlled measurement equipment permits the determination of isolation directly in a manner of minutes.

The isolation determined by this method is independent of the vswr of the sliding load used to terminate the non-isolated port. Hence, the reflection coefficient of the termination may be either greater or less than the true isolation of the circulator, without affecting measurements.

It is possible to apply a similar technique to correct the vswr measurement of the circulator, but the correction would be very small.

Source: R. L. Ernst of  
RCA Corp.  
under contract to  
Goddard Space Flight Center  
(GSC-11106)

*No further documentation is available.*

## THERMAL FLUX SIMULATION

This innovation deals with the production of thermal inputs to an observatory-type spacecraft during thermal vacuum testing, in order to simulate expected orbital solar and albedo inputs. Earlier efforts made use of heater skins that covered the observatory surfaces. Power dissipation of the individual heater skins having various resistances was determined from the product of circuit current and voltage, with the latter monitored by separate taps on each heater. The number of wires required for power supplies and monitoring taxed the thermal vacuum chamber penetration system, resulted in a costly cabling job, and imposed a considerable thermal load on the spacecraft.

This new approach features heater skins of a single resistance value, that permit the accurate determination of power ( $I^2R$ ) by measuring current only into the skins. Elimination of voltage monitoring reduced chamber penetration and cabling requirements by approximately 50%. The heater elements

are made to a precise resistance level from materials such as inconel, evanohm, manganin, etc., which have very low temperature coefficients (0.00004 ohm/ohm/° C or less). This makes any change in circuit resistance over the operating temperature range insignificant. The heaters are connected in a series dc circuit with current adjustment by rheostats that provide the desired heater power dissipation while compensating for any distributive voltage drops in the circuit. Accurate heater current measurements are obtained by means of an inexpensive shunt made of manganin wire.

This technique is useful wherever precise and uniform thermal flux is required. Closely controlled curing of surface coatings would be possible using this approach.

Source: N. Mandell and H. W. Leverone  
Goddard Space Flight Center  
(GSC-11476)

*No further documentation is available.*

TRANSISTOR TEST HEAT CHAMBER

This device permits the testing of transistors under actual operating conditions by simulating a high temperature environment. Previously, transistors that exhibited drift or breakdown under high temperature conditions had to be replaced on a trial and error basis. The unit (Figure 1) is simple and fast operating, and accommodates six transistors at one time. The output of each can be monitored on a curve tracer and, use of breadboard test circuits, permits their performance to be monitored in the actual circuits.

Figure 2 shows the principal components in circuit schematic. The oven circuit is controlled by D1, a silicon controlled rectifier acting as a switch between 6.3 Vac source and the 8-2.7 ohm 1/2 W oven heaters. D1 is controlled by unijunction transistor Q1 which has turn-on, turn-off points regulated by the 5 K ohm helipot in series with the temperature sensor and D2. A drop in oven temperature changes the resistance of the sensor, causing D1 to turn on. As the oven temperature rises, the resultant increase in the sensor resistance switches D1 off.

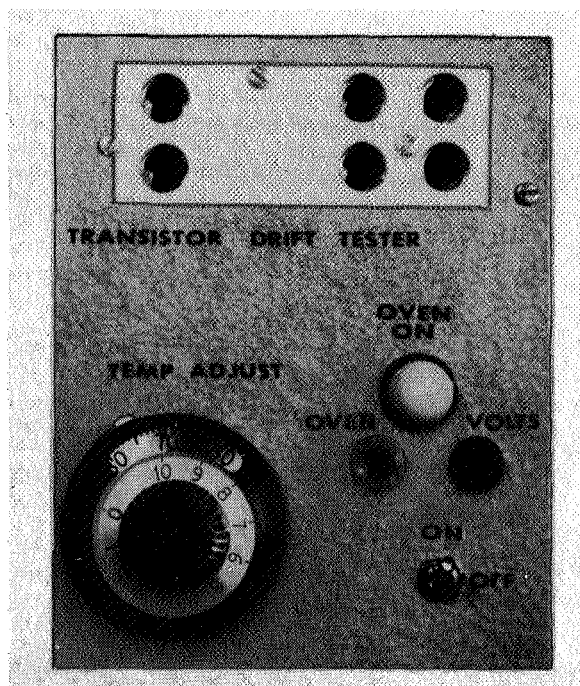

Figure 1

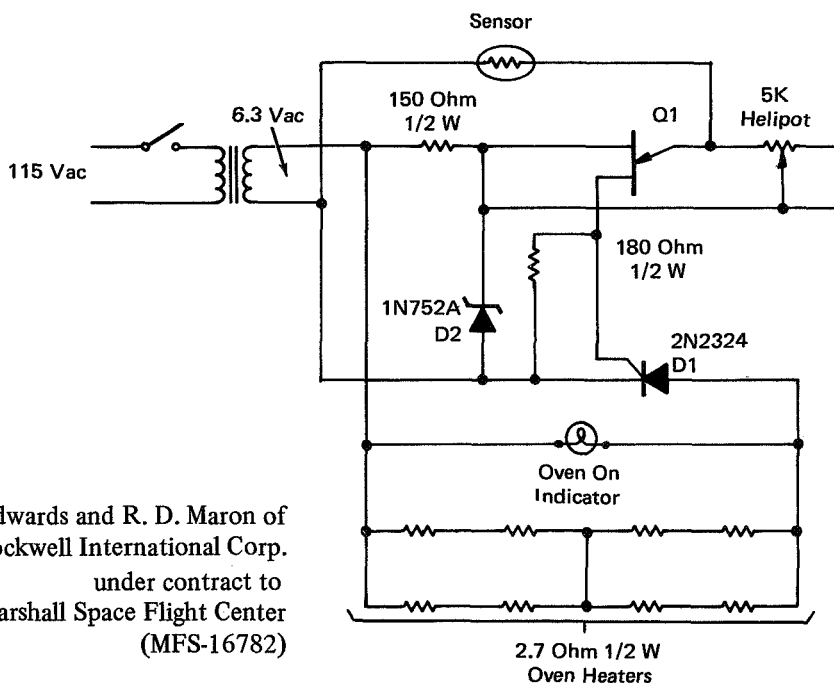
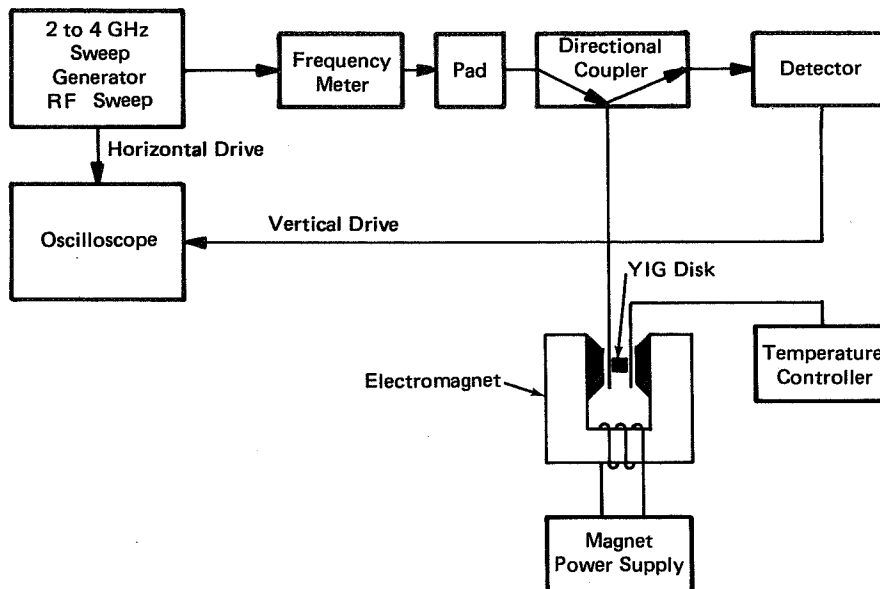

Figure 2

Source: J. E. Edwards and R. D. Maron of Rockwell International Corp. under contract to Marshall Space Flight Center (MFS-16782)

Circle 8 on Reader Service Card.

## TESTER FOR RESONANT FREQUENCIES OF FERRITE DEVICES



The resonant frequency of a maser is determined by the shape of the isolator material, usually an yttrium iron garnet (YIG) disk, and the applied magnetic field. The thickness of the YIG disk is varied to obtain the desired resonant frequency, e.g., to shift the maser frequency 300 MHz would require a 0.00254 cm (0.001-in.) thickness change for a disk that has a 0.117 cm (0.046-in.) diameter and is 0.0165 cm (0.0065-in.) thick. A trial-and-error polishing operation for obtaining the final thickness is time consuming and impractical.

A simple tester has been designed and fabricated which enables the direct measurement of the resonant frequency of a YIG disk. The YIG disk can be tested while mounted on the isolator strip with less regard for dimensional flaws. The tester includes a combination clamp, temperature-controlled electromagnet, and a coupling line element for holding and coupling the signal to the disk under test; the coupling line also receives the reflected signal.

The figure shows a block diagram of the ferrite resonance tester. A microwave signal generator is swept over a particular range of frequencies, the signal being applied to a directional coupler through a frequency meter and pad. The frequency deter-

mining sweep-voltage is applied to the horizontal axis of the oscilloscope; the vertical axis of the oscilloscope receives the detector output voltage which is the rectified, reflected microwave power coupled into the directional coupler from the line. The oscilloscope presentation appears as a straight horizontal line except for a sharp dip which occurs at the resonant frequency of the ferrite; the frequency at the minimal response point is measured with the frequency meter. The directional coupler transfers the microwave signal from the generator to the line and directs the reflected signal from the line to the detector. The magnet is adjusted electrically to provide the desired field strength; this presents an environment similar to that which the YIG ferrite element encounters in a maser. The magnet, directional coupler, strip lines, and YIG disk are maintained at a constant temperature by a thermal control unit.

Source: Robert C. Clauss of  
Caltech/JPL  
under contract to  
NASA Pasadena Office  
(NPO-10678)

Circle 9 on Reader Service Card.

**NONLINEAR RESISTANCE VOLTAGE/CURRENT  
RELATIONSHIPS DETERMINED BY MEASURING HARMONICS**

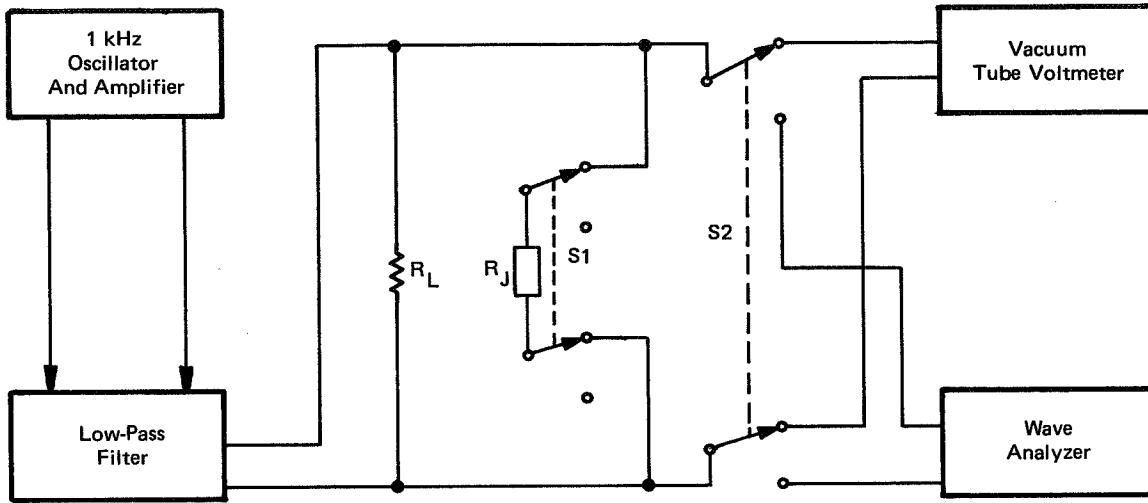

A highly accurate model has been developed that describes voltage-current relations, for determining the intermodulation-product amplitudes generated by a nonlinear resistance. Conventional techniques, involving voltage-current measurements and curve-fitting procedures, do not enable development of a model with the required accuracy.

A test configuration (see figure) is used to measure the amplitudes of the harmonic signals generated in a nonlinear resistance,  $R_J$ , which may be any type of junction. A vacuum-tube voltmeter is used to measure the amplitude (rms) of a low-frequency sinusoidal input signal, and a wave-analyzer measures the amplitude of the harmonic signals generated in the junction. The amplitude of the harmonics contained in the input signal must not exceed the amplitude of the harmonics generated in the nonlinear resistance. Switch S1 is used to remove the nonlinear resistance from the circuit when the input signal harmonic content is measured.

The amplitudes of the harmonic signals are used for determining the short-circuit peak harmonic current,  $I_N$ , in the following equation:

$$I_N = \left[ \frac{1.414 A_N}{R_L} \right] \left[ \frac{R_J + R_L}{R_J} \right]$$

where,  
 $A_N$  = amplitude (rms, volts) of the Nth harmonic,

$R_J$  = effective resistance of the nonlinear resistance

$R_L$  = load resistor, which must be much lower in value than  $R_J$

$\frac{R_J + R_L}{R_J}$  = correction factor which compensates for the effect of  $R_L$  on  $I_N$ .

The peak harmonic currents are inserted into the equations for determining the constants in a truncated power series. These equations are found by accumulating like terms in expansions of  $(A \cos \omega t)^N$ . The constants are substituted in the following equation (truncated power series):

$$I = +K_1 V + K_2 V^2 + K_3 V^3 + \dots + K_N V^N$$

where,  $V = A \cos \omega t$

$A$  = peak value of the input voltage.

This equation describes the voltage-current relation for the nonlinear junction resistance, to the required accuracy.

Source: J. M. Stafford of  
 IBM Corp.  
 under contract to  
 Marshall Space Flight Center  
 (MFS-20402)

Circle 10 on Reader Service Card.



### IMPROVED ANALYSIS OF COIL AND MOTOR WINDING VIBRATION TESTS: A CONCEPT

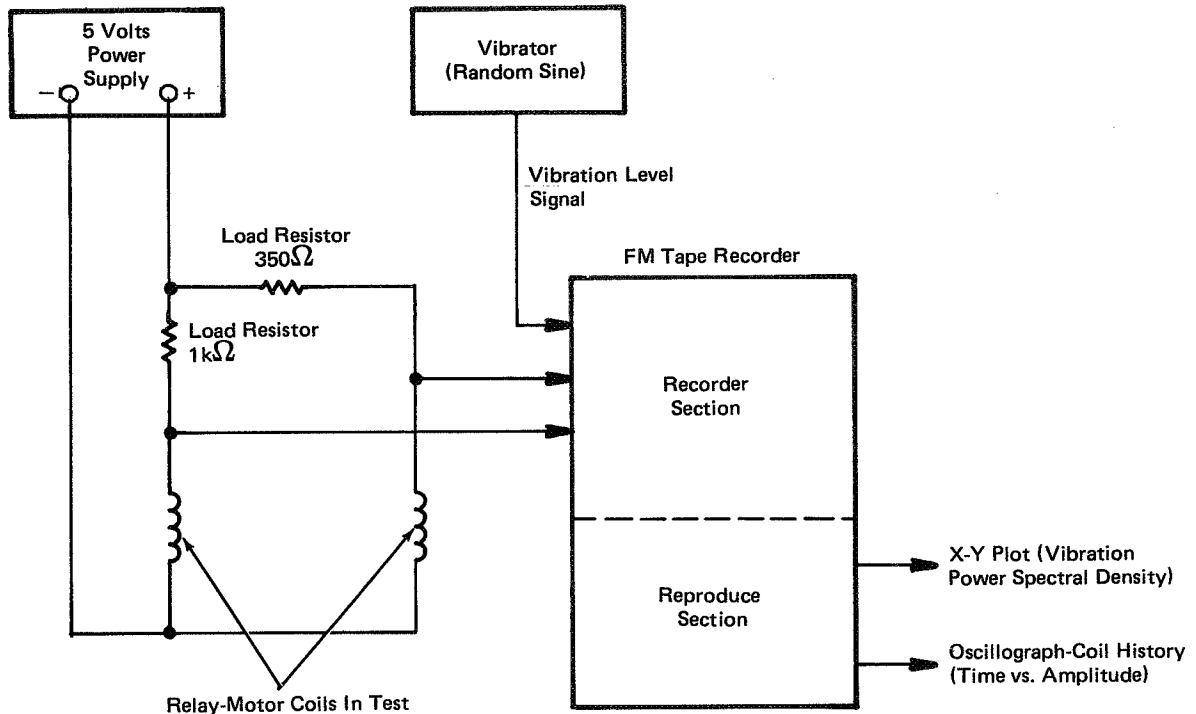

Vibration Testing Circuit Diagram

A new technique provides better data on coil or motor winding rupture from vibration. A low voltage signal (e.g., 5 volts for a 12-volt coil) is applied to the coil or motor winding during the vibration test. The low voltage signal allows continuous monitoring of the coil condition without activating relay coil contacts or associated circuitry.

The test includes recording the signal voltage level and the vibration level on an FM tape recorder for later evaluation. The recorder rate is 60 inches per second at a frequency of 108 kHz. This produces a 20 kHz response for the FM data. An X-Y plotter and oscillograph display the recorded data for analysis.

The displayed data includes the power spectral density and the coil voltage vs time plot. This gives the precise time of coil rupture, the rupture characteristics, and the vibration level that caused the rupture.

Source: L. S. Leura of  
Rockwell International Corp.  
under contract to  
Johnson Space Center  
(MSC-17419)

*No further documentation is available.*

MAGNETIC FIELD MAPPER

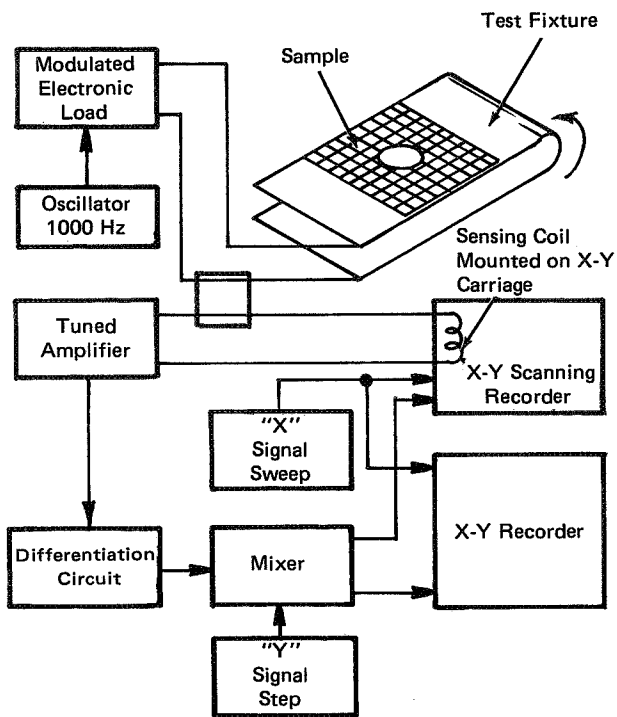

Figure 1. Block Diagram

A magnetic field mapper has been developed for locating imperfections in cadmium sulphide solar cells by detecting and displaying the variations of the normal component of the magnetic field resulting from current density variations. This same technique can be used to inspect for faults and other nonuniformities, such as thickness variations, in other electrically conductive materials.

The apparatus, together with a block diagram of the circuitry, is shown in Figure 1. The principle of operation is based on the fact that a folded flat-loop conductor has a very low external magnetic field as long as the current density in the conductor is uniform. A defect in the conductor, however, causes a nonuniform current density and an external magnetic fringe field. This results in a nonuniform normal component of the magnetic field near the defect. This nonuniform field can be detected with a sensing coil. In this particular instrument, the sensing coil consists of 200 turns of number 56 wire wound on a 1/8 in. (0.318 cm) bobbin.

This coil is mounted on the pen carriage of an X-Y recorder which scans the sample area by receiving signals from an external X sweep and a Y step generator. Sensing coil signals are passed through a polarity sensing transformer which adds a bias signal to determine the direction of the normal magnetic field component. The combined signal is fed to a tuned amplifier which detects and amplifies signals of the same frequency as the input signal. This technique minimizes interference from stray electromagnetic fields.

The signal output of the tuned amplifier is differentiated with respect to the X axis. This results in a signal which varies across the sample conductor in a way similar to the nonuniform current causing the magnetic field. This modified signal is then fed to the Y axis input of an X-Y recorder which is slaved to the X sweep and Y step of the scanning recorder. The resultant family of curves plotted by the X-Y recorder provides a qualitative map or picture of the current distribution over the surface of the flat conductor under test.

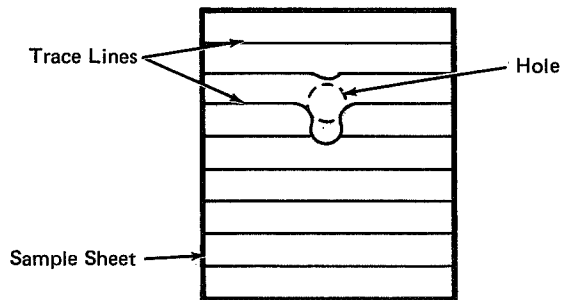

Figure 2. Current Density Topographic Map

A typical family of curves illustrating the magnetic field sensed near a conducting sheet with a hole in it is shown in Figure 2. Magnetic field and hence current density changes are easily observed as the trace moves above or below the average field level.

Source: F. J. Stenger and R. M. Masters  
Lewis Research Center  
(LEW-10782)

*No further documentation is available.*

## HOT RESISTANCE MEASUREMENTS USED TO PREDICT FUSE-BLOW CURRENT LEVELS

Subminiature high reliability fuses, designed for space flight, exhibit blow currents over a wide range (20% is not unusual for fuses of specific rating). This makes derating of fuses for critical applications very difficult due to the lack of baseline data, i.e., blow current value for a particular fuse.

By employing hot resistance measurements and blow current tests, it is possible to predict the approximate blow current value of fuses from a given lot and to limit the blow current values of acceptable fuses to a narrow, defined range.

A hot resistance measurement is taken of each fuse in a lot; i.e. the voltage drop across each fuse is measured at rated current flow after a three-minute stabilization period. The voltage drop is converted to a resistance value and several fuses are then selected for the next step based on their measured hot resist-

ance values so as to span the range of resistances observed for the lot. These fuses are subjected to a stepped current-stress test until their blow current values are reached. A plot of blow current versus hot resistance is made by drawing a curve through the resulting data points. This plot permits prediction of the blow current values of the untested fuses from their measured hot resistance values.

This procedure has been developed using filamentary fuses only and may not hold for other fuse types.

Source: E. F. Thomas  
Goddard Space Flight Center  
(GSC-11442)

*No further documentation is available.*

---

## Section 3. Calibration Devices and Techniques

### CALIBRATION TECHNIQUE FOR ELECTROMAGNETIC FLOWMETERS

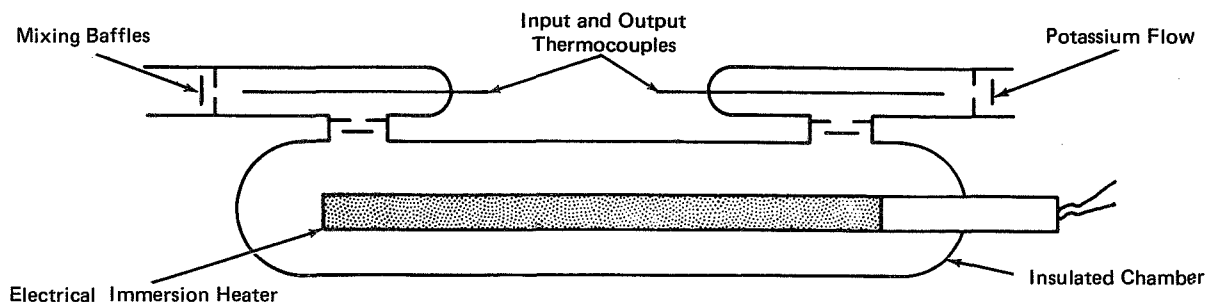

This innovation is used to calibrate electromagnetic flowmeters for liquid alkali metals such as liquid potassium and liquid sodium.

It is a thermal calorimetric method in which the electromagnetic flowmeter is placed in the liquid metal flow system in series with a thermal calorimeter.

An immersion heater is used for heat input to the calorimeter to assure that all of the heat input goes into sensible heat of the liquid metal. To determine the liquid metal flow rate, three parameters have to be known to solve the heat balance equation

$$W = \frac{q}{C_p \Delta T}$$

where

- W = flow rate
- q = heat input to calorimeter
- C<sub>p</sub> = specific heat of liquid metal
- ΔT = liquid metal temperature increase across calorimeter due to heat input

The heat input to the calorimeter through the immersion heater is measured very accurately by a standard wattmeter. The calorimeter heat loss and the systematic temperature measurement error between the inlet and outlet thermocouples are determined by a special technique developed in the process of calibrating the thermocouples.

Simultaneously, as the heat input to the calorimeter and temperature rise of the liquid metal at the inlet and outlet of the calorimeter are recorded, the electromagnetic flowmeter reading is recorded. Since the calorimeter and electromagnetic flowmeter are

in series, the calculated flow rate through the calorimeter can be compared directly with the respective electromagnetic flowmeter reading.

Flow rates calculated from the heat balance equation were used as the basis for calibration of an electromagnetic flowmeter for the liquid metal potassium over the following range of calorimeter conditions:

Potassium flow rate	63.5 to 140.6 g/sec (0.14 to 0.31 lb/sec)
Potassium temperature difference	261.9 to 279.7 K (11.5° to 43.4° F)
Average potassium temperature	589 to 644 K (600° to 700° F)
Calorimeter heat input	0.8 to 1.7 x 10 <sup>3</sup> J/sec (0.76 to 1.6 BTU/sec)

Four sets of calibrations resulted in an average ratio of the calorimeter to electromagnetic flowmeter flow rates of 1.145 with a standard error of ± 1.3%.

The following documentation may be obtained from:

National Technical Information Service  
Springfield, Virginia 22151  
Single document price \$6.00  
(or microfiche \$0.95)

Reference:

NASA CR-851 (N67-35009) Thermal and Hydraulic Performance of Potassium During Condensation Inside Single Tubes

Source: S. G. Sawochka of  
General Electric  
under contract to  
Lewis Research Center  
(LEW-10328)

### "DO IT YOURSELF" SHOCK SPECTRUM ANALYZER

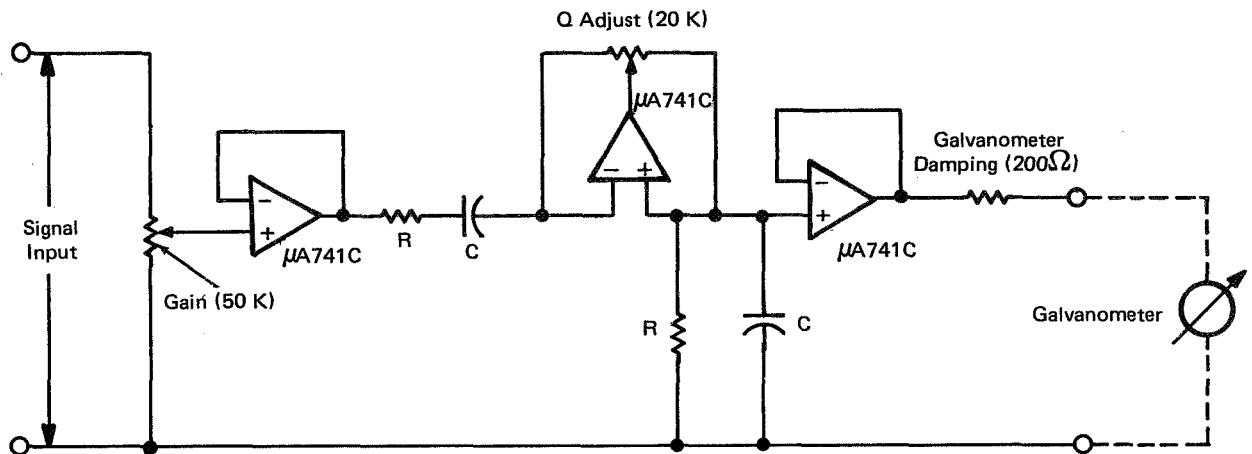

Notes:

1. Center Frequency =  $\frac{1}{2\pi RC}$
2. Filter Circuit Gain = Approx. 2Q
3. Output Amplifier Provides Voltage And Current Limiting For Galvanometer. Signals Greater Than 5V Will Be Limited With The Load Shown.

By use of simple and inexpensive filter elements, most laboratories can construct a shock spectrum analyzer, using standard lab equipment such as tape recorders, amplifiers, oscillographs, etc.

In this approach, the data to be analyzed is recorded on magnetic tape at 30 ips or 60 ips. This data is then played back through a set of active filters and the filtered output is recorded on an oscillograph. The maximum positive peak and the maximum negative peak recorded, therefore, represent the spectral values for each filter frequency. To perform a typical analysis from 10 Hz to 10 KHz, twelve filters are required. Using standard frequencies, the filters would be 12.5 Hz, 14 Hz, 16 Hz, 18 Hz, 20 Hz, 22.5 Hz, 800 Hz, 900 Hz, 1000 Hz, 1120 Hz, 1250 Hz, and 1400 Hz. Other frequencies are achieved by using time multiplication with the tape recorder. For example, if the data is recorded at 60 ips then the 12.5 Hz filter passes 12.5 Hz data when the tape is played back at 60 ips, 25 Hz data when played back at 30 ips, 50 Hz data when played back at 15 ips, 100 Hz when played back at 7.5 ips, and 200 Hz when played back at 3.75 ips.

While this, obviously, is a time consuming process, it does permit an analysis equal or superior to that provided by commercially available analyzers. It also has the additional advantage of recording the filtered data in time domain format rather than frequency domain format. For standard pulse shapes, this is not highly significant; however, for complex wave trains, such as pyrotechnic shock transmission data, this visual picture of the data is of considerable value.

Shock spectrum analysis must be performed at some specific filter value of Q. Inasmuch as the Q value varies with the type of data, filters of variable Q are required. In this case, fixed frequency, variable Q, variable gain filters are ideal. A circuit employing such filters is shown in the figure. These filters have independent gain and Q adjustments and are tuned by selection of the R-C networks.

Source: K. M. Murphy of  
Rockwell International Corp.  
under contract to  
Johnson Space Center  
(MSC-17196)

*No further documentation is available.*

## CONTINUOUS SOURCE OF VACUUM ULTRAVIOLET BELOW 500 Å

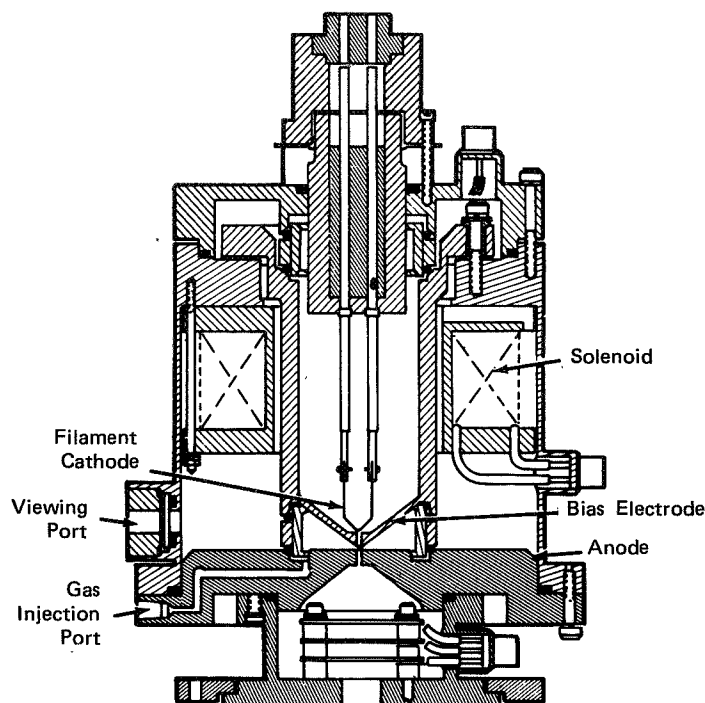

This innovation consists of a small continuously operating source of ultraviolet radiation in the wavelength region between 10 and 1,000Å. Present devices are so large (with energetic arc columns to 6 foot length) as to be inconvenient as laboratory tools.

The duo plasmatron type source is a modification of the Von Ardenne duo plasmatron. The source produces spectral lines below 500 Å in a helium environment, measured by a 1/2-meter, grazing incidence spectrometer.

The magnetic components, anode, bias electrode, and that portion of the outer chamber between these two electrodes are of soft iron. A solenoid of 1,000 turns of #18 copper wire produces the necessary magnetic field. The nose cone of the bias electrode saturates first in the magnetic circuit. This saturation occurs at about 12,000 gauss, being induced by a solenoid current of 2 amperes. This produces a magnetic field of about 7,000 gauss between the bias and anode electrodes. The bias electrode placed between the cathode and anode has a small aperture at its apex to restrict the arc.

The duo plasmatron design creates a magnetic mirror field in the region of high ion density and acts to reflect the electrons so that escape is possible

only very near the axis. The arc is thus caused to draw down to a very small conical envelope coming to a point at the anode where ion densities of  $6 \times 10^{14}$  ions/cm<sup>3</sup> occur.

Helium is used for spectral line investigation and is introduced to the area of the ionizing arc through an injection port in the source body. The point source is located 5 cm from the entrance slit of the grazing incidence spectrometer.

Because the spectra produced are determined almost completely by the gas injected, and because the source operates continuously, this arrangement should be beneficial in the development and calibration of filters and detectors within discrete wavelength ranges. The duo plasmatron source has produced high ion densities from relatively low power input and the entire source assembly occupies a volume of only 100 cubic inches.

Source: Space Sciences Inc.  
under contract to  
Goddard Space Flight Center  
(GSC-545)

Circle 11 on Reader Service Card.

## A COMPACT ROTARY VANE ATTENUATOR

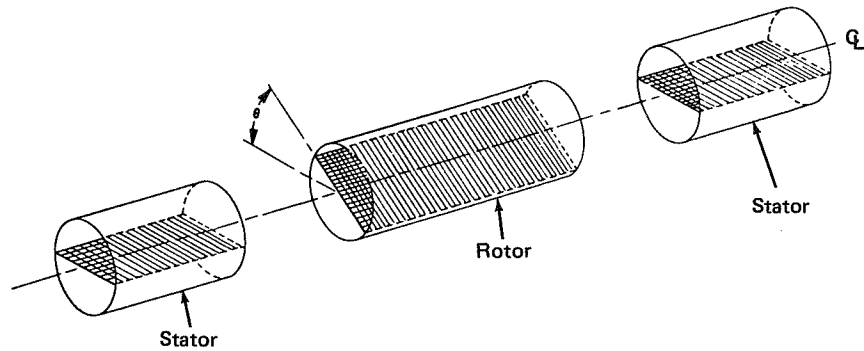

In the procedure for calibrating microwave receivers, the signal to noise ratio must be determined. An I.F. attenuator introduces a nonlinearity during the calibration procedure due to inaccuracies in the attenuator itself and nonlinearities in the amplifiers.

This rotary vane attenuator, when used as a front end attenuator, introduces an insertion loss that is proportional to the angle of rotation. The nonlinearities of the amplifiers no longer affect the results. A technique is developed to allow the construction of a shortened compact unit suitable for use in most installations.

Basically, the rotary vane attenuator consists of three sections of waveguide in tandem. A resistive film is placed across each section of waveguide. The middle section is a short length of circular waveguide which is free to rotate axially with respect to the two fixed end sections; the end sections are rectangular-to-round waveguide transitions in which the resistive films are normal to the field of the applied wave. When all films are aligned, the E field of the applied wave is normal to the films, no current flows and no attenuation occurs. If the center film is rotated to an angle  $\theta$  the E field is divided into two components: one in the film plane and the other normal to the film. The component in the film plane is completely absorbed while the normal component passes unattenuated to the third section where a similar process takes place. The component that finally emerges is at the same orientation as the original wave and has undergone an attenuation, in

decibels, of  $40 \log \cos \theta$ . The attenuation is thus ideally proportional only to the angle at which the center film is rotated and is completely independent of frequency. This simple formula neglects many sources of error and assumes infinite rotor attenuation loss in the E field component in the plane of the film.

A study has been made of vane angle readout errors, misalignment and mismatch errors, phase shift, and vane rotor attenuation loss. The effects of these sources of error on calibration accuracy have been determined from a detailed error analysis. Classically, the error due to finite rotor loss is minimized by making the rotor very long, the approach used here is to shorten the rotor and account for the finite rotor loss with an "exact" theoretical analysis based on a computer program. This method can also be used with any rotary vane attenuator to improve the accuracy of the simplified formula.

Documentation is available from:

National Technical Information Service  
Springfield, Virginia 22151

Price \$3.00

Reference: TSP69-10427

Source: C. T. Stelzried, T. Y. Otoshi,  
and D. L. Nixon of  
Caltech/JPL  
under contract to  
NASA Pasadena Office  
(NPO-10562)

**FLAW SIMULATOR FOR EDDY CURRENT PROBE CALIBRATION**

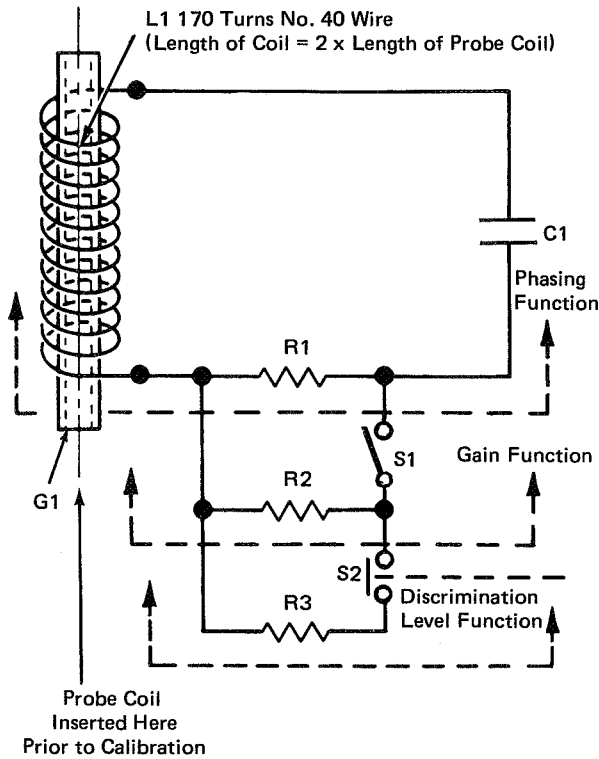

Eddy current probes are effective tools for the nondestructive location of flaws in materials. In the past the calibration of probes has consisted of passing the probe coils over materials containing flaws of known dimensions. The major disadvantage is that these reference flaws change in time due to undetected dust collection, chipping, and handling wear.

This device is an electronic flaw simulator cycled by switching into the eddy current system.

As shown in the figure, the eddy probe coil is inserted into sleeve G1 which is a flaw-free material

identical to the material being tested. Next, the probe rf bridge is balanced in the proper phase using the null network (G1, L1, R1 and C1). The proper phase is an optimized reference range of the rf bridge, and at the midpoint of the typical variation realized for conductivity effect. System gain adjustment is accomplished by switching S1-R2 into the tank circuit and loading the probe to a selected level within the operating range of the rf bridge. The gain adjustment is included as an integral part of the simulator to assure day-to-day consistency in the operation.

The simulation of a flaw is accomplished by intermittent loading of the probe through a variation in the impedance of the tank circuit. The mechanism by which the probe motion past a flaw is simulated is shown as switch S2; the impedance variation is simulated by R3. The magnitude of the simulated flaw is a reference equivalent volume obtained by measuring the rf bridge sensitivity to a selected physical standard. A discrimination level reference is thus established wherein any flaws with an equivalent volume equal to or greater than the reference will be recognized.

This technique provides a system calibration time saving of 1/5 over prior methods. The first electronic simulator has been in use since 1968 without measurable change in performance. Minor maintenance has not adversely affected calibration.

Source: C. D. Cowfer and L. J. Almasy of Westinghouse Astronuclear Lab. under contract to Space Nuclear Systems Office (NUC-10211)

*Circle 12 on Reader Service Card.*



## AN IMPROVED ATOMIC HYDROGEN FREQUENCY AND TIME STANDARD

A newly developed hydrogen maser frequency and time standard is highly stable and accurate over long periods of time and suitable for tracking-station environments. Use of a large bulb, long-multipole magnet, automatic tuner, and aluminum cavity provides an improved hydrogen maser.

Cost, size, weight, and the need for special training to operate the maser have been restraining factors in its widespread use in laboratories. When this problem was recognized, work was started to improve the maser and develop auxiliary systems for its use by nonspecialists. An experimental model, which has been operating continuously, is providing stable signals and further experimental data. Based on the experimental work, four complete prototype field operable standards have been designed and constructed and are in operation and undergoing tests.

The new model, which utilizes an aluminum cavity, provides several advantages: (1) electrically opaque, (2) reproducible high Q, (3) mechanically stable, (4) readily available and, (5) inexpensive. The large thermal expansion, fifty times that of fused silica, can be used advantageously to tune the cavity. This eliminates the need for problematic mechanical tuners, or varactor diode tuning methods. Long-term cavity drifts, although small, are corrected completely by a unique automatic cavity tuner which is part of the system.

One improvement incorporated by this maser is the use of a bulb much larger than usual. Use of the large bulb is based upon operation of the cavity very near waveguide cutoff diameter, where the frequency depends primarily upon diameter and loading, while the length may be increased as desired.

Modifications have been made to the state selector, for example, a long, small bore, high-flux multipole magnet is used to "capture" the maximum possible flux of upper state atoms from the source, and to remove the lower state atoms from the beam. The long magnet was found to be desirable because it assures that a larger number of atoms actually enter the bulb.

The information described in this innovation may be of interest to personnel working with masers and atomic frequency standards.

Documentation is available from:

National Technical Information Service

Springfield, Virginia 22151

Price \$3.00

Reference: TSP69-10341

Source: H. E. Peters, T. E. McGunigal,

and E. H. Johnson

Goddard Space Flight Center

(GSC-10706)

---

## Patent Information

The following innovation, described in this Compilation, is being considered for patent action as indicated below:

**Spark Transducer Generates Ultrasonic Energy (Page 9) MFS-21233**

This invention is owned by NASA, and a patent application has been filed. Inquiries concerning nonexclusive or exclusive license for its commercial development should be addressed to:

Patent Counsel  
Marshall Space Flight Center  
Code A&PS-PAT  
Marshall Space Flight Center, Alabama 35812

---