

NASA-TMX - 72535

B18562

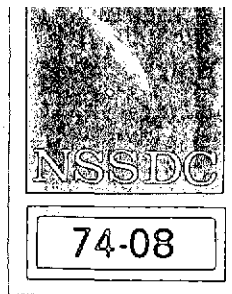

DATA USERS NOTE

APOLLO 17
LUNAR PHOTOGRAPHY

December 1974

(NASA-TM-X-72535) DATA USERS NOTE: N75-14672
APOLLO 17 LUNAR PHOTOGRAPHY (NASA) 69 p
HC \$4.25 CSCL 03B
Unclas
63/91 07216



NATIONAL SPACE SCIENCE DATA CENTER

NATIONAL AERONAUTICS AND SPACE ADMINISTRATION • GODDARD SPACE FLIGHT CENTER, GREENBELT, MD.

DATA USERS NOTE

APOLLO 17 LUNAR PHOTOGRAPHY

by

Winifred Sawtell Cameron;¹ Frederick J. Doyle;²
Leon Levenson, Kenneth Michlovitz³

National Space Science Data Center
Goddard Space Flight Center
National Aeronautics and Space Administration
Greenbelt, Maryland 20771

December 1974

¹ National Space Science Data Center

² United States Geological Survey

³ PMI Facilities Management Corporation

PREFACE

The purposes of this data users note are to announce the availability of Apollo 17 pictorial data and to aid an investigator in the selection of Apollo 17 photographs for study. As background information, the note includes a brief description of the Apollo 17 mission and mission objectives. The National Space Science Data Center (NSSDC) can provide photographic and supporting data as described in the section on Description of Photographic Objectives, Equipment, and Available Data. The section also includes descriptions of all photographic equipment used during the mission. The availability of any data received by NSSDC after publication of this note will be announced by NSSDC in a data announcement bulletin.

NSSDC will provide data and information upon request directly to any individual or organization resident in the United States and, through the World Data Center A for Rockets and Satellites (WDC-A-R&S), to scientists outside the United States. All requesters should refer to the section on Ordering Procedures for specific instructions and for NSSDC policies concerning dissemination of data.

PRECEDING PAGE BLANK NOT FILMED

CONTENTS

	<u>Page</u>
PREFACE	iii
INTRODUCTION	1
MISSION SCIENCE OBJECTIVES	3
DESCRIPTION OF PHOTOGRAPHIC OBJECTIVES, EQUIPMENT, AND AVAILABLE DATA	5
Service Module Photography	8
Mapping Camera System	8
Panoramic Camera	18
Command Module Photography	28
Command Module Hasselblad Electric Camera (HEC)	32
Command Module Maurer Camera	35
Nikon Camera	39
Westinghouse TV Camera	39
Lunar Surface and Lunar Module Photography	43
Lunar Module Hasselblad Electric Data Cameras (HEDC)..	43
Lunar Module Maurer Camera	44
RCA TV Camera	46
ORDERING PROCEDURES	49
ACKNOWLEDGMENTS	53
LIST OF ACRONYMS AND ABBREVIATIONS	55
REFERENCES	57
SOURCE LIST	59
APPENDIX A - EXPERIMENTS PACKAGE	A-1
APPENDIX B - SAMPLES OF APOLLO 17 PHOTOGRAPHY	B-1

ILLUSTRATIONS

<u>Figure</u>		<u>Page</u>
1	SIM Bay Mapping Camera System - Mapping Camera/ Stellar Camera/Laser Altimeter Detail	9
2	Mapping Camera Film Format (in millimeters).....	11

ILLUSTRATIONS (continued)

<u>Figure</u>		<u>Page</u>
3	Stellar Camera Film Format (in millimeters)	12
4	Laser Altimeter Block Diagram	13
5	Sample of Mapping Camera Supporting Data	16
6	Sample of Mapping Camera Frame Index Ordered by Frame Number	17
7	Sample of Mapping Camera Frame Index Ordered by Longitude	17
8	Panoramic Camera Enclosure and SIM Mounting	19
9	Principal Components of the Panoramic Camera	20
10	Panoramic Camera Photography Stereo Coverage and Overlap (25° Convergence Angle)	22
11	Lunar Surface Footprint for Panoramic Camera Photograph taken from 110-km Orbit	22
12	Image of 5000 Meter Square Grid on Moon's Surface as Recorded by Apollo Panoramic Camera at 12.5° Forward Pitch from 110-km Nominal Altitude	23
13	Transforming Printer for Apollo Panoramic Camera Photography	24
14	Comparison of Transformed Print to Total Area Photographed	26
15	Sample of Panoramic Camera Supporting Data	29
16	Sample of Panoramic Camera Frame Index Ordered by Frame Number	30
17	Sample of Panoramic Camera Frame Index Ordered by Longitude in 10° Increments	31
18	Sample of Orbital Hasselblad Camera Frame Index Ordered by Frame Number	36
19	Sample of Hasselblad and Nikon Cameras Frame Index Ordered by Longitude in 10° Increments	36
20	Sample of Maurer Camera Film Index	37
21	NSSDC Maurer Camera Photography Index Ordered Chronologically	38
22	Sample of Nikon Photography Index Ordered by Frame Number	41
23	Sample Page of the Index to the Nikon Photography as Supplied by the Principal Investigator	42
24	Sample of Surface Hasselblad Camera Frame Index Ordered Chronologically Indicating Activity	45

TABLES

<u>Table</u>		<u>Page</u>
1	Summary of Apollo 17 Primary Photographic Equipment	6
2	Summary of Usable Apollo 17 Mapping Camera Photographs	15
3	Summary of Usable Apollo 17 Panoramic Camera Photographs	27
4	Summary of Apollo 17 Hasselblad 70-mm Film Magazines	33
5	Summary of Apollo 17 Nikon 35-mm Film Magazines	40
6	NSSDC Summary of Apollo 17 TV Kinescope Film Log	47

APOLLO 17 LUNAR PHOTOGRAPHY

INTRODUCTION

Apollo 17 (1972-096A), the last manned lunar mission of the Apollo series, was launched from Cape Kennedy, Florida, at 0533 UT on December 7, 1972, and returned to earth at 1924 UT December 19, 1972. The major components of the Apollo spacecraft were a Command Module (CM), the primary vehicle for translunar coast (TLC) and transearth coast (TEC); the Service Module (SM), which carried the major power equipment and also housed the Scientific Instrument Module (SIM); and the Lunar Module (LM), which transported the astronauts and equipment, including the Lunar Roving Vehicle (LRV) which was the astronauts' transportation vehicle on the surface. The CM and SM remained connected throughout the mission to just before reentry. This mission was the third of the three J-series missions, which carried the LRV for increased mobility of the astronauts during periods of extravehicular activity (EVA). The J-series spacecraft, which was designed to remain in the lunar environment longer than those of the earlier G and H missions, also carried an enhanced science equipment complement.

The total duration of the mission was 12.6 days; total time in lunar orbit was 148 hours; total time on the surface was 75 hours; and the total EVA time was a record 22.1 hours. Astronaut Eugene A. Cernan was the commander (CDR) of the mission, Ronald E. Evans was the Command Module (America) pilot (CMP), and Dr. Harrison H. Schmitt, the first and only scientist astronaut to participate in a lunar landing, was the Lunar Module (Challenger) pilot (LMP).

Lunar orbit insertion (LOI) occurred on December 10, 1972, at 1949 UT. At LOI the orbit was 314 x 97 km. On the third revolution the orbit was changed to 109 x 28 km; then it was circularized to 130 x 100 km on revolution 13. No further changes were made except in inclination, which on revolution 48 was changed to 23° from the initial 20°. It remained at 23° for the rest of the orbital mission. The LM landed in the Taurus-Littrow area (30.8°E, 20.2°N) on December 11, 1972, at 1955 UT (2:55 P.M. EST). The astronauts (Cernan and Schmitt) collected and returned 113.2 kg (249 lb) of lunar material and covered 37 km during their three EVA excursions before lifting off the surface of the moon at 2256 UT on December 14, 1972. The LM shortly thereafter joined with the CSM which had been orbiting the moon during the surface exploration. Evans (the CMP) had conducted many orbital scientific experiments during that time. During the TEC, astronaut Evans performed a space EVA to transfer the film cassettes from the SIM to the CM.

MISSION SCIENCE OBJECTIVES

The primary scientific objectives were to:

1. Perform selenological inspection and survey and sample materials and surface features in preselected areas of the Taurus-Littrow region.
2. Emplace and activate surface experiments.
3. Conduct inflight experiments and tasks.

The orbital and surface activities of the astronauts continued and expanded the exploration of the lunar environment begun in the three previous fly-by missions (Apollo 8, 10, and 13) and the five manned landings (Apollo 11, 12, 14, 15, and 16).

There were 13 orbital experiments and 11 surface experiments. For a complete listing of the Apollo 17 experiment package, see Appendix A. Only the photographic experiments conducted both from orbit and on the surface will be discussed in this document. The other experiments and the resultant data are described in the "Apollo 17 Preliminary Science Report," NASA SP-330,¹ and in the "Apollo Data Users Handbook"² being prepared at NASA Johnson Space Center.

The purposes of the CM photographic tasks were: (a) to obtain photographs of lunar surface features of scientific interest and (b) to obtain photographs of astronomical sources and lunar features of low brightness. Astronomical targets were: diffuse galactic light of selected celestial objects, the solar corona, the zodiacal light, and any comets that might be available. Lunar targets were: features in earthshine (ashen light) and near-terminator features (very low angles of illumination). SIM photographic objectives were to obtain:

1. High-resolution panoramic photographs of the lunar surface.
2. High-quality metric photographs of the lunar surface simultaneously with stellar attitude photographs.
3. Laser range measurements of spacecraft altitude.

The surface photographic objectives were:

1. To photograph terrain and surface characteristics of the Taurus-Littrow landing area.
2. To document samples collected in situ.
3. To photograph Apollo lunar surface experiments packages (ALSEPs) after deployment.

DESCRIPTION OF PHOTOGRAPHIC OBJECTIVES, EQUIPMENT, AND AVAILABLE DATA

The Apollo 17 mission returned more photographs than any previous Apollo mission. The dominant photographic mission was to record lunar surface features, with additional coverage of spacecraft maneuvers and views of celestial and terrestrial objects. During the 6-day stay in the lunar environment, the visible terminator advanced 75° , permitting extended surface area coverage under a range of lighting conditions. The sunset terminator advanced from 151°W to 134°E , and the sunrise terminator from 29°E to 46°W selenographic longitude.

The photographic tasks were divided among the Command, Service, and Lunar Modules and the surface. Table 1 contains the characteristics of the cameras used on this mission.

Distributed with this data users note are eight footprint maps which serve as photography indexes. These maps indicate the areas of orbital photographic coverage for the following cameras:

1. Panoramic camera photography, composite for all revolutions
2. Mapping camera photography, revolutions 1/2, 14/15, 27/28, 38, 66
3. Mapping camera photography, revolutions 13/14, 23/24, 28/29, 49, 74
4. Mapping camera photography, revolutions 26/27, 36, 62, 65
5. Hasselblad camera photography, magazines KK, NN, OO, PP, QQ
6. Hasselblad camera photography, magazines A, D, LL, MM, RR
7. Hasselblad camera photography, magazine K; Nikon camera photography, magazines SS, VV, XX, YY; and Maurer camera photography, magazines BB, EE, O, Q
8. Nikon camera photography, magazines WW, ZZ

Samples showing the various format sizes of Apollo 17 photography are included in Appendix B of this note, and a form for ordering Apollo 17 photographic and supporting data follows Appendix B.

PRECEDING PAGE BLANK NOT FILMED

Table 1
Summary of Apollo 17 Primary Photographic Equipment

CAMERA	FOCAL LENGTH (mm)	APERTURE OPENING	IMAGE FORMAT (mm)	FOCUS (m)	SHUTTER SPEED (sec)	FIELD OF VIEW (deg)	CASSETTE CAPACITY	EK FILM NUMBER	FILM TYPE
SERVICE MODULE PHOTOGRAPHY									
Mapping	76	f/4.5	115 x 115	∞	automatic	74 x 74	467 m	3400	B/W Plus X Aerial
35-mm Mapping-Stellar	76	f/2.8	24 x 32	∞	1.5	18.0 vert 24.0 hor	157 m	3401	B/W Plus XX
Panoramic	610	f/3.5	115 x 1150	∞	automatic	11 (fore, aft) 108 (across)	1975 m	3414	B/W High Def Aerial
COMMAND MODULE PHOTOGRAPHY									
70-mm Hasselblad Electric (HEC)	80	f/2.8	52 x 52	1 to ∞	0.002, 0.004, 0.009, 0.018-0.5	37.9 (side)		SO-368	CEX, MS
						51.8 (diag)		2485	B/W, Very High Speed
	250	f/5.6	52 x 52	2.6 to ∞	0.002 to 1.0	12.5 (side) 17.6 (diag)		SO-368 2485	CEX, MS B/W, Very High Speed
16-mm Maurer Data Acquisition (DAC)	10	T1.0 to T22	8 x 10	0.2 to ∞	0.001 to 0.0167 T(time) 1,6,12,24 fps	54.9 (hor)		SO-368	CEX, MS
						41.1 (vert)		SO-168	EF
						65.2 (diag)		2485	B/W
						32.6 (hor)		SO-368	CEX, MS
	18	T1.0 to T22	8 x 10	0.03 to ∞		23.4 (vert)		SO-168	EF
						39.2 (diag)		2485	B/W
	75	T2.4 - T22	8 x 10	1.1 to ∞		7.9 (hor)		SO-368	CEX, MS
						5.7 (vert)		SO-168	EF
						10.0 (diag)		2485	B/W
	229 (with sextant)	T8	8 x 10	∞	0.0167	2.1 (circ)		SO-368	CEX, MS

Table 1 (continued)

CAMERA	FOCAL LENGTH (mm)	APERTURE OPENING	IMAGE FORMAT (mm)	FOCUS (m)	SHUTTER SPEED (sec)	FIELD OF VIEW (deg)	CASSETTE CAPACITY	FILM NUMBER	FILM TYPE
COMMAND MODULE PHOTOGRAPHY (continued)									
35-mm Nikon with red, blue, and polarizing filters	55	f/1.2	24 x 36	∞	0.001 to 1.0 or B	36.0 (hor) 24.0 (vert)		2485 SO-168	B/W EF
Westinghouse TV	--	f/4 to f/44	8 x 10*	0.5 to ∞	30 fps			SO-394	Color Kinescope
LUNAR SURFACE AND LUNAR MODULE PHOTOGRAPHY									
70-mm Hasselblad Electric Data (HEDC)	60 reseau	f/11, f/5.6	52 x 52	1, 2.9, 3.1, 22.9, 0.7, 4.6	0.004, 0.002 to 1.0	46.9 (side) 63.4 (diag)		SO-368 3401	MS B/W Plus XX
70-mm Hasselblad Electric Data (HEDC)	500 reseau	f/11, f/8	52 x 52	1000	0.004	6.2 (side) 8.8 (diag)		SO-368 3401	MS B/W Plus XX
16-mm Maurer Data Acquisition (DAC)	10	T1.0 to T22	8 x 10	0.2 to ∞	variable	54.9 (hor) 41.1 (vert) 65.2 (diag)		SO-368	MS
RCA TV	GCTA/12.5-75-mm zoom	f/2.2 to f/22	video 8 x 10*	0.6 to ∞ 0.5 to ∞	30 fps		3036 m	SO-394	Color Kinescope

*NSSDC image area film format.

SERVICE MODULE PHOTOGRAPHY

The Service Module (SM) photographic tasks were to provide:

1. High-quality mapping camera metric photographs of the lunar surface while simultaneously exposing stellar photographs for precise orientation of the spacecraft and recording laser altimeter data for determination of spacecraft altitude.
2. High-resolution (2-3 m) panoramic photographs of the lunar surface with stereoscopic and monoscopic coverage.

Task 1 was accomplished using the assembly of the Fairchild mapping (metric) camera, a stellar camera, and the RCA ruby laser altimeter; and task 2 was performed using the Itek optical bar panoramic camera.

Mapping Camera System

The mapping camera system (MCS), shown in Figure 1, contained three major components:

- . Mapping (metric) camera
- . Stellar camera
- . Laser altimeter

The fixed angle between the optical axis of the mapping camera and the optical axis of the stellar camera was nominally 96° , with the stellar camera pointing 6° above the horizon on the right side of the spacecraft when the mapping camera was pointing vertically toward the lunar surface and the spacecraft was moving forward. The laser altimeter transmission and receiving optical axes were nominally parallel to the mapping camera optical axis. The actual angular orientation between the mapping and stellar cameras and the location of the altimeter subpoint in the mapping camera frame are given as part of the preflight calibration data, which are included in the "SIM Bay Photographic Equipment and Mission Summary, Apollo 17 Supplement."³

During camera operation, the MCS was mechanically deployed outside the SIM bay to provide a clear field of view for the stellar camera. The stellar lens glare shield was extended during the deployment process. The midpoint of exposure of the mapping camera, stellar camera, and laser altimeter was synchronized to ± 1 msec.

Exposed film from both mapping and stellar cameras was accumulated in the removable film record container. This container was recovered from the SIM bay by the Command Module pilot (CMP) by EVA during the transearth coast.

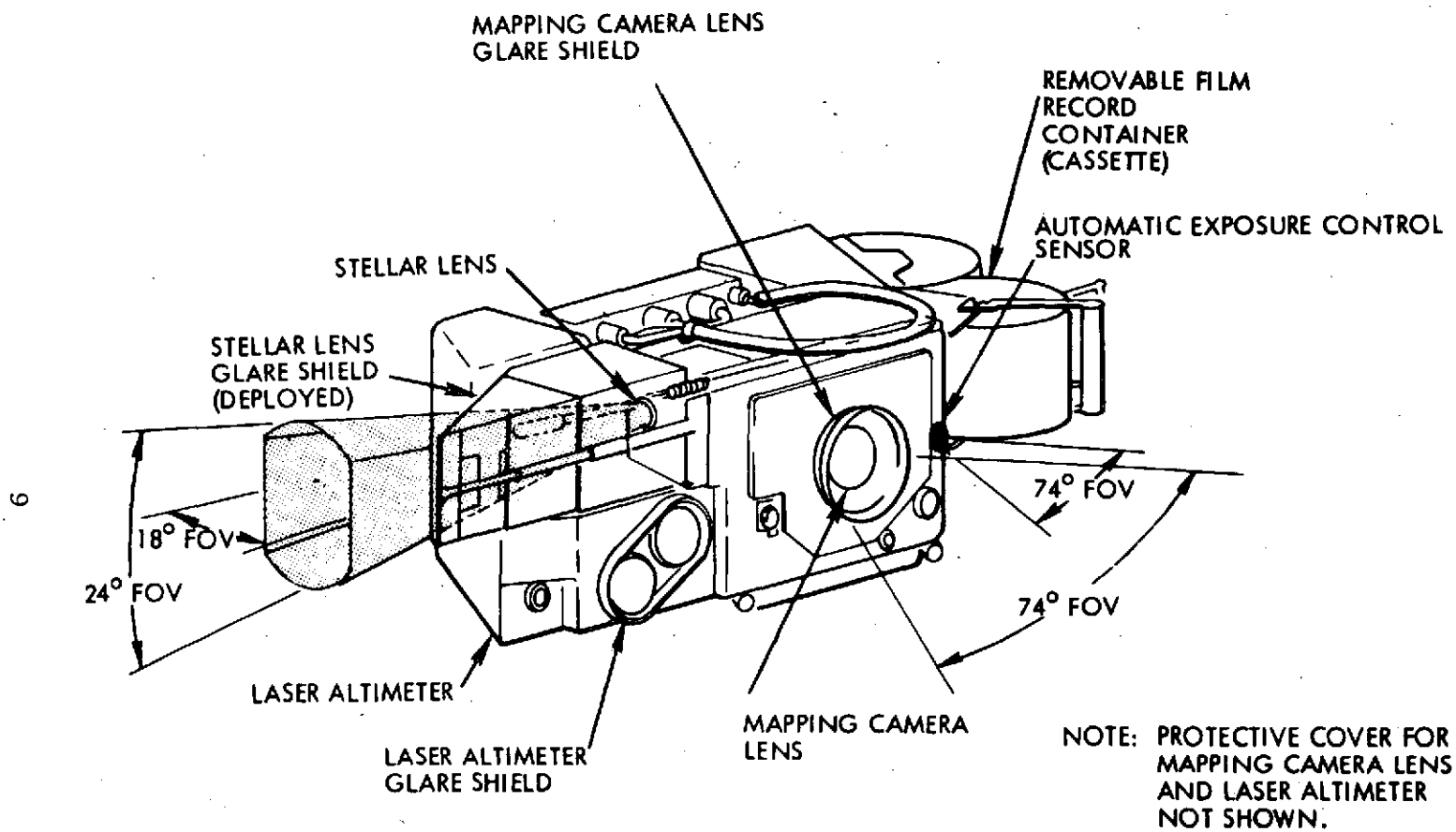

Figure 1. SIM Bay Mapping Camera System - Mapping Camera/Stellar Camera/Laser Altimeter Detail

Mapping Camera

The objectives of the mapping camera photography were to provide:

1. Data for establishing a unified selenodetic reference system.
2. Imagery suitable for photomapping at scales as large as 1:250,000.
3. Imagery at approximately 20-m ground resolution suitable for synoptic interpretation of geologic relationships and surface material distribution.

The mapping camera had an f/4.5 lens of 76-mm (3-in.) focal length and a picture format of 115 x 115 mm (4.5 x 4.5 in.) on 127-mm (5-in.) roll film. The 74° field of view covered approximately 170 x 170 km (92 x 92 n.m.) from the nominal altitude of 110 km (60 n.m.).

As shown in Figure 2, there were four naturally illuminated fiducials (V notches in the midpoint of each side) and eight artificially illuminated fiducials (points of light outside the picture format). The optical axis was located with respect to these fiducials by the preflight calibration data. The glass focal plane of the camera contained a reseau (array of crosses) that was imaged on each frame. The calibrated dimensions of the reseau provide a means of checking film distortion after processing. The reseau and the film were moved together during the exposure to assure sharp imagery by compensating for the forward motion of the spacecraft. There were five discrete forward motion compensation (FMC) rates (plus OFF) that were manually selected by the CMP according to spacecraft altitude. The position of the reseau with respect to the fiducials is variable from frame to frame. The format also contains a binary coded decimal data block in which spacecraft time, shutter open time, and altimeter distance reading are recorded.

The camera operated at full aperture at all times. An exposure sensor automatically set the shutter speed at one of seven speeds between 0.067 and 0.004 sec.

The overlap between successive frames was 78 percent. By using alternate frames, this may be reduced to the standard 57 percent.

Stellar Camera

The objective of the stellar camera was to photograph the star field in synchronism with mapping camera and laser altimeter pulses. By measurement of the position of identified star images, the orientation of

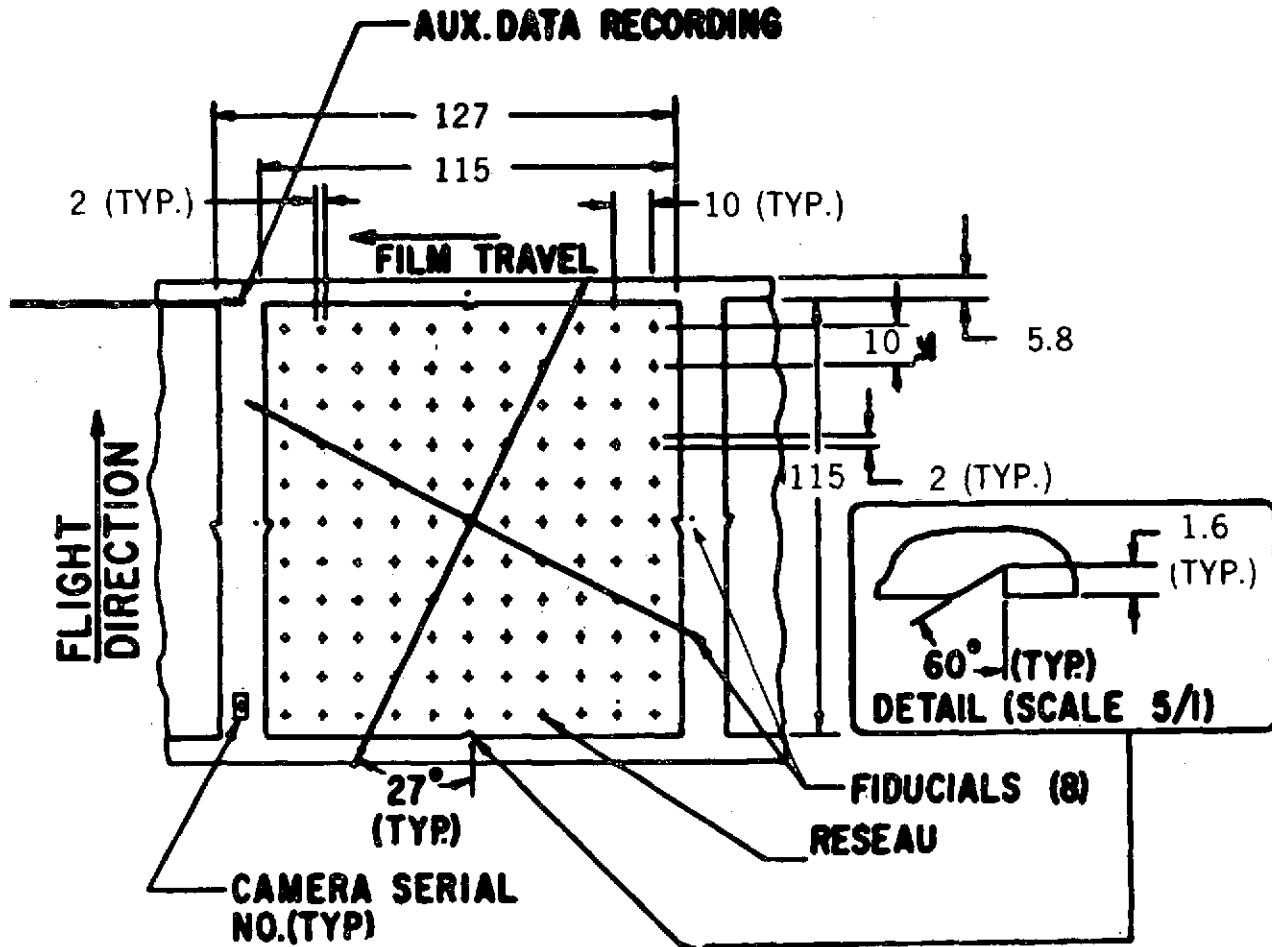

Figure 2. Mapping Camera Film Format (in millimeters)

the stellar camera in the celestial coordinate system could be determined. By means of the preflight calibration, this orientation was transferable to the mapping camera or to the laser altimeter.

The stellar camera carried an f/2.8 lens with a 76-mm focal length and has a picture format of 24 x 32 mm (0.96 x 1.25 in.). The photography was originally recorded on 35-mm roll film and later contact-printed on 70-mm film.

The stellar camera film format is shown in Figure 3. There were four naturally illuminated fiducials. The fixed glass focal plane contained a reseau that was edge-illuminated to record on each frame.

The exposure time for the stellar camera was fixed at 1.5 sec, and the midpoint of this exposure was synchronized with the midpoint of the mapping camera and laser altimeter to ± 1 msec.

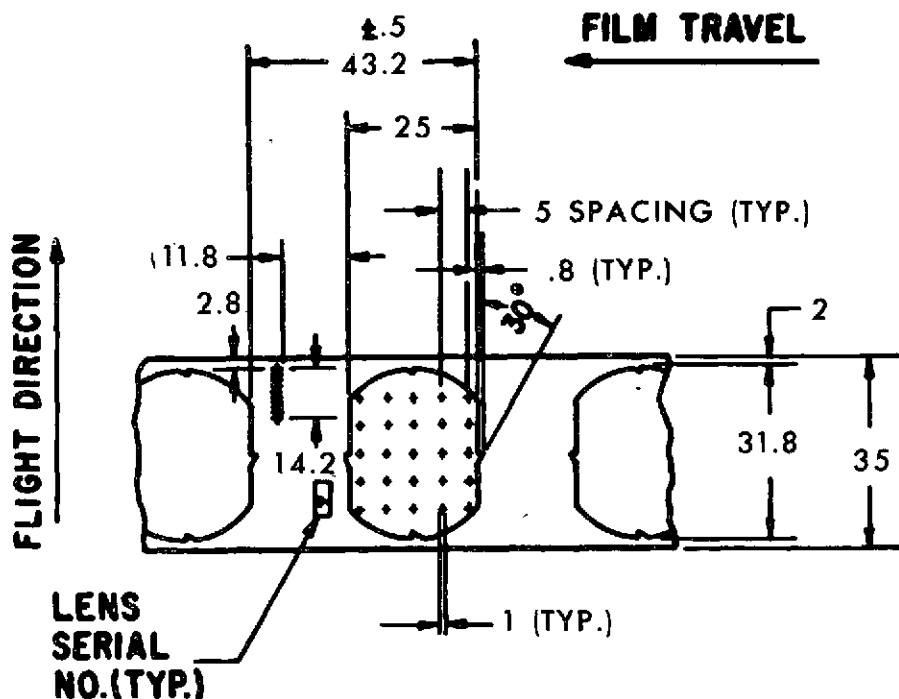

Figure 3. Stellar Camera Film Format (in millimeters)

Laser Altimeter

The objectives of the laser altimeter were to provide:

1. A measured distance from the spacecraft to the lunar surface in synchronism with each frame exposed by the metric camera photography.
2. Lunar surface height profiles on the dark side.
3. Additional data to the orbital tracking data for use in orbit and gravity field analysis.

Figure 4 is a block diagram of the altimeter. When a signal was received from the mapping camera, the ruby laser was activated and the light pulse was transferred to the transmission optics that had an angular field of $300 \mu\text{rad}$ illuminating an area 33 m in diameter on the lunar surface from a nominal altitude of 110 km. A portion of the output was used to start the range counting clock. The return pulse reflected from the lunar surface was applied to the photomultiplier tube through the receiver telescope that had an angular field of $200 \mu\text{rad}$. The output of the photomultiplier stopped the range counter that had a least count of 1 m. The altitude was recorded both on the mapping camera film and in the spacecraft data system.

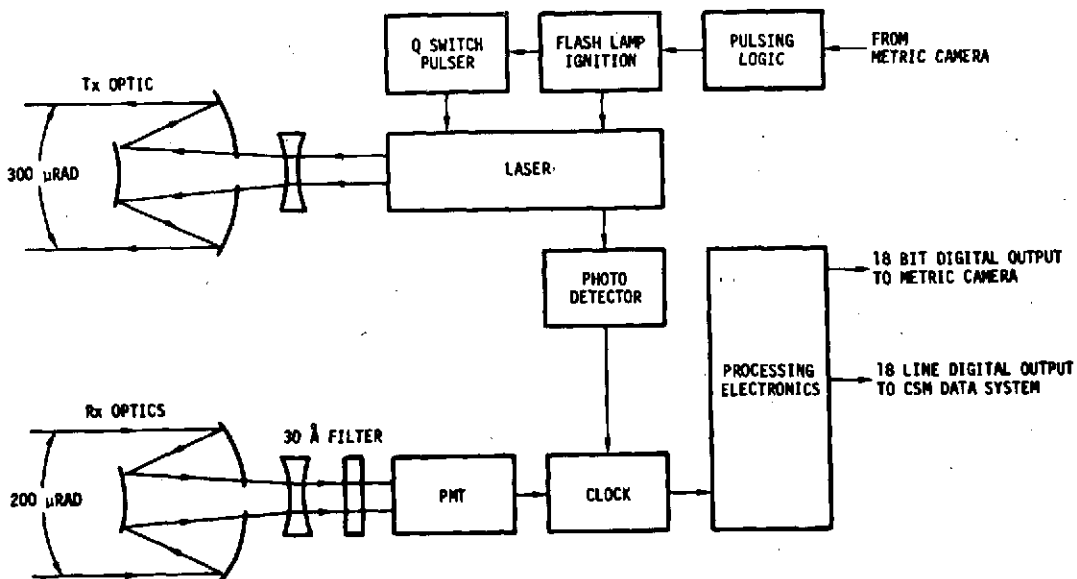

Figure 4. Laser Altimeter Block Diagram

Mapping Camera System Photographic and Supporting Data

NSSDC has in its repository five rolls of normal gamma mapping camera photography in the form of second generation master positives and a duplicate set of second generation direct negatives with each exposure on the roll being in a 115- x 115-mm (4.5- x 4.5-in.) format. In addition, two of these five rolls were processed at high gamma to accentuate highlight areas. Table 2 gives a summary of mapping camera coverage relating the frame numbers with orbital revolution numbers. The imagery contains 2,140 usable frames out of 3,289 numbered frames. Individual mapping camera frames can be obtained as: (1) 127- x 127-mm (5- x 5-in.) negative or positive contact film or contact paper prints, or (2) 203- x 254-mm (8- x 10-in.) paper enlargements. Enlargements in other format sizes can be prepared up to 508 x 610 mm (20 x 24 in.) upon request. The 115- x 115-mm (4.5- x 4.5-in.) image area on the 127-mm film is enlarged to approximately 190 x 190 mm (7.5 x 7.5 in.) on the 203- x 254-mm (8- x 10-in.) enlargements. Strips of consecutive frames, or the complete set of mapping camera photography, can be obtained as contact negative film or positive film or paper duplicates on 127-mm rolls. Orders for individual frames should specify the frame number (e.g., AS17-0464). A photographic catalog of the mapping camera photographs is available on one reel of 16-mm microfilm or on microfiche. Two versions of the microfiche are available, one prepared by the California Institute of Technology that is suitable for use with automated microfiche retrieval systems, and the other prepared by NSSDC from the 16-mm roll films and inserted into microfiche jackets. Most users will find the NSSDC version of the microfiche suitable for picture selection purposes. The overall quality of the two products is considered equivalent.

Mapping camera supporting data are available on one reel of 16-mm microfilm. Figure 5 is a sample of the mapping camera supporting data. Some explanatory terms precede the data. (For an explanation of all items in these data, see "SIM Bay Photographic Equipment and Mission Summary, Apollo 17 Supplement."³) In addition, a one-line frame index for this photography is available on 16-mm microfilm or on microfiche. Included on this same 16-mm reel of indexes are one-line frame indexes for the photography from the panoramic, Hasselblad, Nikon, RCA TV, and Maurer cameras. The mapping camera and panoramic camera frame index data are contained on the same microfiche. The mapping camera (and panoramic camera) indexes are arranged in two orders: (a) by frame number (Figure 6) and (b) by longitude in increments of 10 degrees (Figure 7). Users will receive paper prints of the supporting data frames and indexes appropriate for the photographic frames requested. In cases of requests for a significant quantity, or a complete set of mapping camera photography, film copies of the supporting data will be supplied to the requester on one reel of 16-mm microfilm.

Table 2

Summary of Usable Apollo 17 Mapping Camera Photographs

REV	ATTITUDE	NASA PHOTO NOS. AS17-	NO. FRAMES	START		STOP	
				LAT.	LONG.	LAT.	LONG.
1/2	VERT	0163-0316	154	20.1S	151.1W	19.7N	27.1E
13/14	VERT	0322-0460	139	19.7S	164.5W	19.4N	14.8E
14/15	NORTH OBLIQUE	0464-0472	9	15.6S	163.3W	18.1S	174.9W
	VERT	0473-0612	140	18.3S	176.2W	19.4N	15.2E
23/24	VERT	0667-0814	148	19.6S	174.3W	19.7N	5.0E
26/27	NORTH OBLIQUE	0820-0961	142	17.3S	176.0W	22.2N	1.5E
27/28	VERT	1094-1243	150	19.6S	178.0W	19.6N	0.7E
28/29	VERT	1376-1525	150	19.6S	178.6W	19.6N	0.8E
36	SOUTH OBLIQUE	1543-1686	144	22.9S	174.5E	16.5N	6.8W
38	VERT	1687-1833	147	19.6S	173.8E	19.4N	8.4W
39	VERT	1966-1972	7	19.4S	172.0E	--	--
49	VERT	1979-2123	145	22.1S	162.4E	21.6N	19.2W
62	FWD OBLIQUE	2151-2205	55	21.5S	144.7E	1.9S	84.0E
	VERT	2206-2298	93	1.3S	82.5E	21.8N	31.9W
65	NORTH OBLIQUE	2344-2351	8	18.6S	144.3E	17.7S	139.5E
		2352-2371	20	7.5S	103.6E	1.6N	80.7E
	S/C MNVR	2372-2377	6	1.6N	79.1E	0.1S	70.5E
	SOUTH OBLIQUE	2378-2460	83	0.0	69.4E	18.4N	34.8W
66	VERT	2591-2735	145	21.8S	145.1E	21.7N	36.8W
74	VERT	2790-2937	148	21.6S	135.3E	21.7N	45.1W
TEC		3183-3289	107	5.1S	117.9E	--	--
		TOTAL	2,140				

Each revolution begins at the 180° meridian. The designation "1/2" in the REV column indicates that the camera was turned on in revolution one and continued in operation across the 180° meridian into revolution two.

YEAR MONTH DAY HOUR MINUTE SECOND
 1972 12 12 23 30 2.397
 CTE 8 17 87 4.009

STATE VECTOR X (KM) Y (KM) Z (KM) XDOT (KM/S) YDOT (KM/S) ZDOT (KM/S)
 19000 -1410.709896 -830.2582179 352.0303765 -.5269529 1.3223093 .7279010
 GELNOCENTRIC 1464.6762727 950.6374378 610.2529473 .8292949 -1.3940377 .1307610

LONGITUDE OF NADIR POINT 32.7039007 DEG LATITUDE OF NADIR POINT 19.2451398 DEG
 32 DEG, 07 MIN, 2.2074481 SEC 19 DEG, 15 MIN, 59.8033485 SEC
 LONG OF CAMERA AXIS INTERSECT 33.2590193 DEG LATI OF CAMERA AXIS INTERSECT 22.9400094 DEG
 33 DEG, 15 MIN, 35.3313990 SEC 22 DEG, 29 MIN, 29.0326000 SEC
 SPACECRAFT RADIUS 1049.5870000 KM SPACECRAFT ALTITUDE 111.9970717 KM
 SCALE FACTOR .0005000 M/KM AZIMUTH OF VELOCITY VECTOR 275.3535947 DEG
 MEAN ALTITUDE RATE -.0140011 KM/SEC HORIZONTAL VELOCITY 1.0278660 KM/SEC
 TILT AZIMUTH 9.8933290 DEG TILT ANGLE 40.2232397 DEG
 SIGMA TILT AZIMUTH .0003097 DEG SIGMA TILT ANGLE .0002000 DEG
 SUN ELEVATION AT PRIN GND PNT 20.0770566 DEG SUN AZIMUTH AT PRINCIPAL GND PNT 103.0009442 DEG
 LONGITUDE OF SUBSOLAR POINT 92.2702085 DEG LATITUDE OF SUBSOLAR POINT .7321771 DEG
 92 DEG, 16 MIN, 12.7505630 SEC 0 DEG, 42 MIN, 55.8375263 SEC
 ALPHA SCISSOR ANGLE 359.9002162 DEG
 EMISSION ANGLE 43.9006447 DEG SIGMA SCISSOR ANGLE .0003096 DEG
 PHASE ANGLE 69.1090622 DEG NORTH DEVIATION ANGLE 173.4016242 DEG
 PHI .0009089 DEG X-TILT 40.2206434 DEG
 SIGMA PHI .0002619 DEG SIGMA X-TILT .0002000 DEG
 KAPPA -174.6316357 DEG Y-TILT -.3821804 DEG
 SIGMA KAPPA .0002619 DEG SIGMA Y-TILT .0002000 DEG
 OMEGA 40.2206430 DEG HEADING .04.9548232 DEG
 SIGMA OMEGA .0002000 DEG SIGMA HEADING .0002000 DEG
 SPACECRAFT ALTITUDE (LASER) .0000000 KM LASER SLANT RANGE .0000000 KM

GELNOCENTRIC DIRECTION COSINES X Y Z MAGNITUDE (KM)
 OF CAMERA AXIS -.81090010 -.46463567 .35572707 149.843967

TRANSFORMATION MATRIX FROM
 GELNOCENTRIC TO CAMERA

TRANSFORMATION MATRIX FROM
 LOCAL HORIZONTAL TO CAMERA

.3388574600 .8269786400 .4513783700
 .2846572100 .6472496400 -.7870766000
 .8967417300 -.1302125500 -.4204101900

-.9941034600 .8793924001 .6669737602
 -.71437916001 -.70021923000 -.69579207000
 .51714851001 .64369322000 .76383422000

PHOTOGRAPH FOOTPRINT
 LATITUDE LONGITUDE
 .0000000 .000
 19.264 35.339
 19.659 30.594
 .0000000 .000

DIRECTION TO STELLAR PHOTO CENTER

RIGHT ASCENSION -0 HR, 15 MIN, 40.7 SEC DECLINATION 47 DEG, 42 MIN, 10.7 SEC

Figure 5. Sample of Mapping Camera Supporting Data

APOLLO 17
MAPPING CAMERA PHOTOGRAPHS

NASA PHOTO AS17-	PRINCIPAL POINT		CAMERA		ALT. KM.	REV NO.	SUN EL.	DESCRIPTION
	LAT.	LONG.	TILT	AZ				
917	18.0 N	62.2 E	40	14	119	27	55	EIMMART, C, CRISES, SEA OF
918	18.2 N	61.2 E	40	14	118	27	54	EIMMART, C, CRISES, SEA OF
919	18.7 N	59.9 E	40	13	118	27	52	EIMMART, C, CRISES, SEA OF
920	18.7 N	58.6 E	40	12	118	27	51	EIMMART, C, CRISES, SEA OF
921	19.1 N	56.8 E	40	12	117	27	50	PEIRCE, B, CRISES, SEA OF
922	19.5 N	54.9 E	40	11	117	27	48	PEIRCE, B, CRISES, SEA OF
923	19.8 N	53.5 E	40	10	117	27	47	PEIRCE, B, CRISES, SEA OF
924	20.2 N	52.2 E	40	10	116	27	46	PEIRCE, B, CRISES, SEA OF
925	20.6 N	50.7 E	40	10	116	27	44	PEIRCE, B, CRISES, SEA OF
926	20.8 N	49.4 E	40	10	116	27	43	TISSERAND, MACROBIUS
927	21.0 N	47.9 E	40	10	115	27	42	TISSERAND, MACROBIUS
928	21.1 N	46.6 E	40	10	115	27	40	TISSERAND, MACROBIUS
929	21.2 N	45.0 E	40	9	115	27	39	TISSERAND, MACROBIUS
930	21.6 N	43.5 E	40	9	114	27	38	MACROBIUS, A, B
931	21.9 N	41.9 E	40	8	114	27	36	MACROBIUS, A, B
932	21.9 N	40.6 E	40	8	113	27	35	MACROBIUS, A, B, ROMER
933	22.2 N	39.3 E	40	7	113	27	34	MACROBIUS, A, B, ROMER
934	22.3 N	37.5 E	40	6	113	27	32	ROMER, MARALDI
935	22.5 N	35.9 E	40	6	112	27	31	ROMER, MARALDI
936	22.7 N	34.6 E	40	5	112	27	29	ROMER, MARALDI
937	22.9 N	32.9 E	40	5	111	27	28	APOLLO 17 LANDING SITE
938	22.9 N	31.6 E	40	4	111	27	27	APOLLO 17 LANDING SITE
939	23.1 N	29.8 E	40	4	111	27	25	APOLLO 17 LANDING SITE
940	23.1 N	28.9 E	40	3	110	27	24	APOLLO 17 LANDING SITE
941	23.3 N	27.3 E	40	3	110	27	23	LE MONNIER, SERENITY, SEA OF

Figure 6. Sample of Mapping Camera Frame Index Ordered by Frame Number

APOLLO 17
MAPPING CAMERA PHOTOGRAPHS
INDEXED BY LONGITUDE 30 TO 40 E

NASA PHOTO AS17-	PRINCIPAL POINT		CAMERA		ALT. KM.	REV NO.	SUN EL.	DESCRIPTION
	LAT.	LONG.	TILT	AZ				
302	19.9 N	38.8 E	VERT		251	02	11	ROMER, MARALDI
303	19.9 N	38.0 E	VERT		253	02	10	APOLLO 17 LANDING SITE, IN SHADOW
304	19.9 N	36.6 E	VERT		254	02	9	APOLLO 17 LANDING SITE, IN SHADOW
305	19.9 N	35.3 E	VERT		256	02	8	APOLLO 17 LANDING SITE, IN SHADOW
306	19.9 N	34.2 E	VERT		258	02	7	APOLLO 17 LANDING SITE, IN SHADOW
307	19.9 N	32.9 E	VERT		260	02	6	APOLLO 17 LANDING SITE, IN SHADOW
308	19.8 N	31.6 E	VERT		262	02	4	APOLLO 17 LANDING SITE, IN SHADOW
309	19.8 N	30.5 E	VERT		264	02	3	APOLLO 17 LANDING SITE, IN SHADOW
441	19.8 N	38.6 E	VERT		115	14	21	MACROBIUS A, B
442	20.0 N	37.1 E	VERT		115	14	20	MARALDI
443	20.1 N	35.9 E	VERT		115	14	19	MARALDI
444	20.2 N	34.6 E	VERT		114	14	18	MARALDI, VITRUVIUS
445	20.3 N	32.8 E	VERT		114	14	16	APOLLO 17 LANDING SITE
446	20.2 N	31.3 E	VERT		114	14	14	APOLLO 17 LANDING SITE
589	19.7 N	39.6 E	VERT		115	15	23	MACROBIUS A, B

Figure 7. Sample of Mapping Camera Frame Index Ordered by Longitude

The 35-mm stellar photography has been contact-printed onto 70-mm film and is available in that format. The stellar photographs, however, have marginal value outside of their use in the analysis of the attitude for the mapping camera photographs and the laser altimeter data. The stellar photographs do not have the same frame numbers as the mapping camera frames. To determine the stellar frame number corresponding to a particular mapping camera frame number, subtract 18 from the mapping camera frame number. For example, the stellar frame number taken simultaneously with mapping (metric) frame AS17-0464 is stellar AS17-0446.

Panoramic Camera

The objectives of the panoramic camera were to provide:

1. High-resolution (2-3 m) coverage of all areas overflowed by the spacecraft in sunlight for detailed interpretation of surface features,
2. Photographic imagery suitable for the compilation of topographic maps of limited areas at scales as large as 1:10,000.

As shown in Figure 8, the panoramic camera was rigidly mounted in the SIM bay structure. The scan angle was 108° across the flight line. When operating in the stereo mode, the camera alternated between 12.5° forward and 12.5° aft of the nadir to provide a 25° convergent angle between successive frames.

The principal components of the camera are shown in Figure 9. The main frame assembly carried the film supply and take-up reels, power supply, drive mechanism, telemetry, and film shuttle rollers. The gimbal structure assembly was pivoted about a transverse axis so that it could rock fore and aft to provide the 25° stereo convergence between frames. This rocking motion was also used to compensate for spacecraft forward motion during the actual camera exposure. The gimbal structure also carried skew rollers to lead the film around the roller cage. The roll frame assembly, which was mounted on a longitudinal axis in the gimbal structure, carried the folded optical system in the lens barrel and the roller cage around which the film passed during the exposure.

During camera operation, the roll frame assembly rotated continuously. Film was exposed during the 108° scan centered on the nadir. During the remaining part of the rotation, the film was transported and the gimbal structure tilted from the forward to the aft position (or vice versa) to provide the 25° stereo convergence.

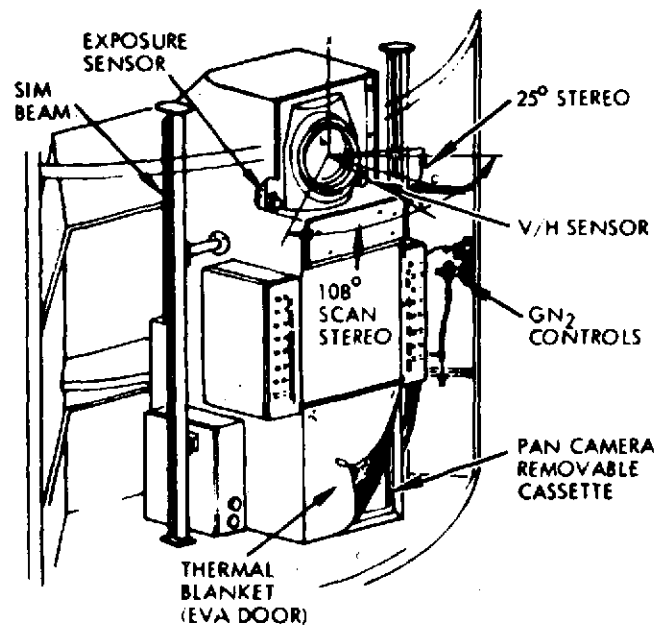

Figure 8. Panoramic Camera Enclosure and SIM Mounting

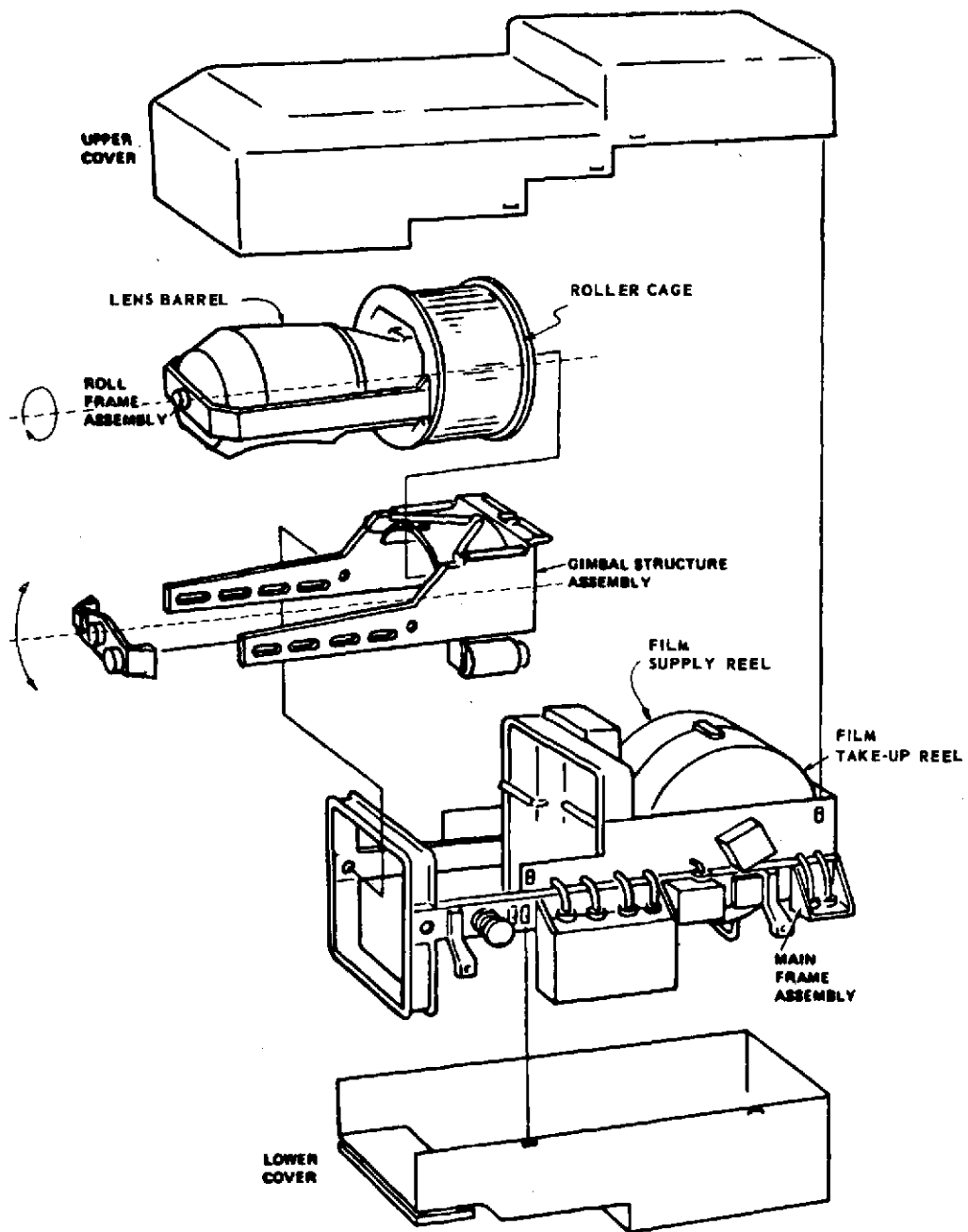

Figure 9. Principal Components of the Panoramic Camera

A velocity/height (V/H) sensor on the main frame sensed the rate of apparent ground motion and governed the rotation rate of the roll frame assembly. An exposure sensor mounted on the gimbal structure recorded the scene brightness and adjusted the film exposure by varying the slit width in the optical system.

Typical stereo coverage is illustrated in Figure 10. A stereo pair is made up from the forward-looking frame at exposure station 1 and the aft-looking frame from exposure station 6. The two elements of the pair are thus separated by five frame numbers. The typical lunar surface footprint for a single frame is shown in Figure 11.

The quality of most of the photography is good. The number of usable frames of high resolution of the lunar surface from the panoramic camera totals 1574.

NSSDC has second generation master positives, which are stored on 127-mm roll film. Each frame has an image area of 115 x 1150 mm (4.5 x 45 in.) covering 21 x 330 km of the lunar surface at the 110-km altitude.

Panoramic Camera Rectified Photography

Photographs produced by a panoramic camera are inherently different from those made by a frame camera. A frame exposed by the Apollo mapping camera, for instance, is made at a single instant of time, from a single point in space, and with the camera axis vertical. A panoramic photograph, on the other hand, requires a finite time for the entire strip of film to be exposed. During this time the lens rotates through an angle of 108° across the vehicle track, 1219 mm (48 in.) of film travels through the camera, the spacecraft moves forward about 4 km along its orbit, the entire optical system is aimed 12.5° forward or aft of the vertical, and the gimbal frame rocks about a transverse axis in order to compensate for the forward motion of the vehicle. The result of all these dynamic motions is a picture with a continuously varying scale. If there were a square grid ruled on the surface of the Moon, it would be imaged on the film as a distorted grid as shown in Figure 12. Stereoscopic viewing, interpretation, and mapping from such distorted images are difficult and require very sophisticated and costly instrumentation.

In order to remove these distortions and convert the panoramic photographs into equivalent frame photographs, the Apollo Transforming Printer, shown in Figure 13, was developed. This instrument essentially duplicates the action of the panoramic camera by projecting the image from the film to an easel which represents the Moon's surface. It effectively takes the distorted grid of Figure 12 and transforms it back to a square grid.

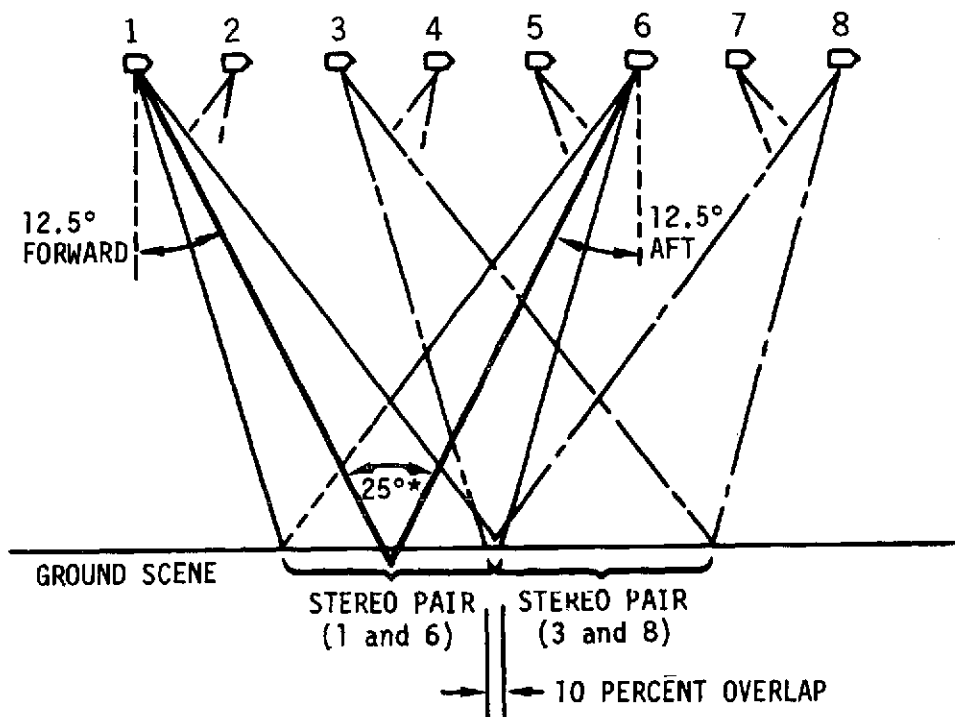

*CONVERGENCE ANGLE

Figure 10. Panoramic Camera Photography Stereo Coverage and Overlap (25° Convergence Angle)

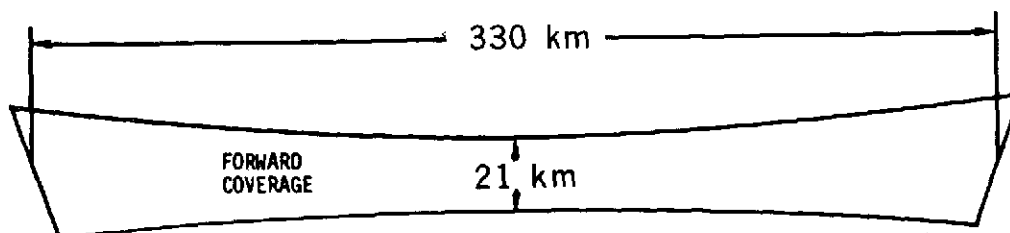

Figure 11. Lunar Surface Footprint for Panoramic Camera Photograph taken from 110-km Orbit

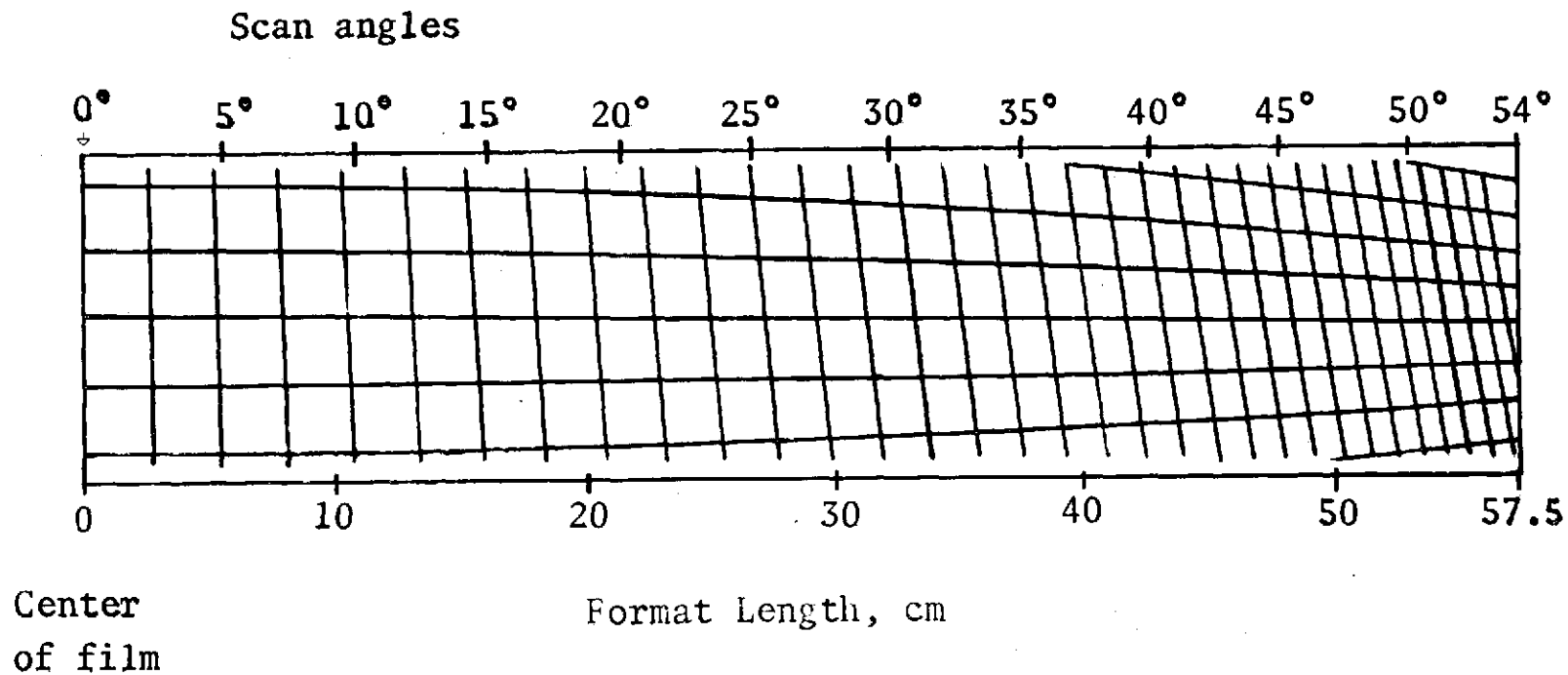

Figure 12. Image of 5000 Meter Square Grid on Moon's Surface as Recorded by Apollo Panoramic Camera at 12.5° Forward Pitch from 110-km Nominal Altitude

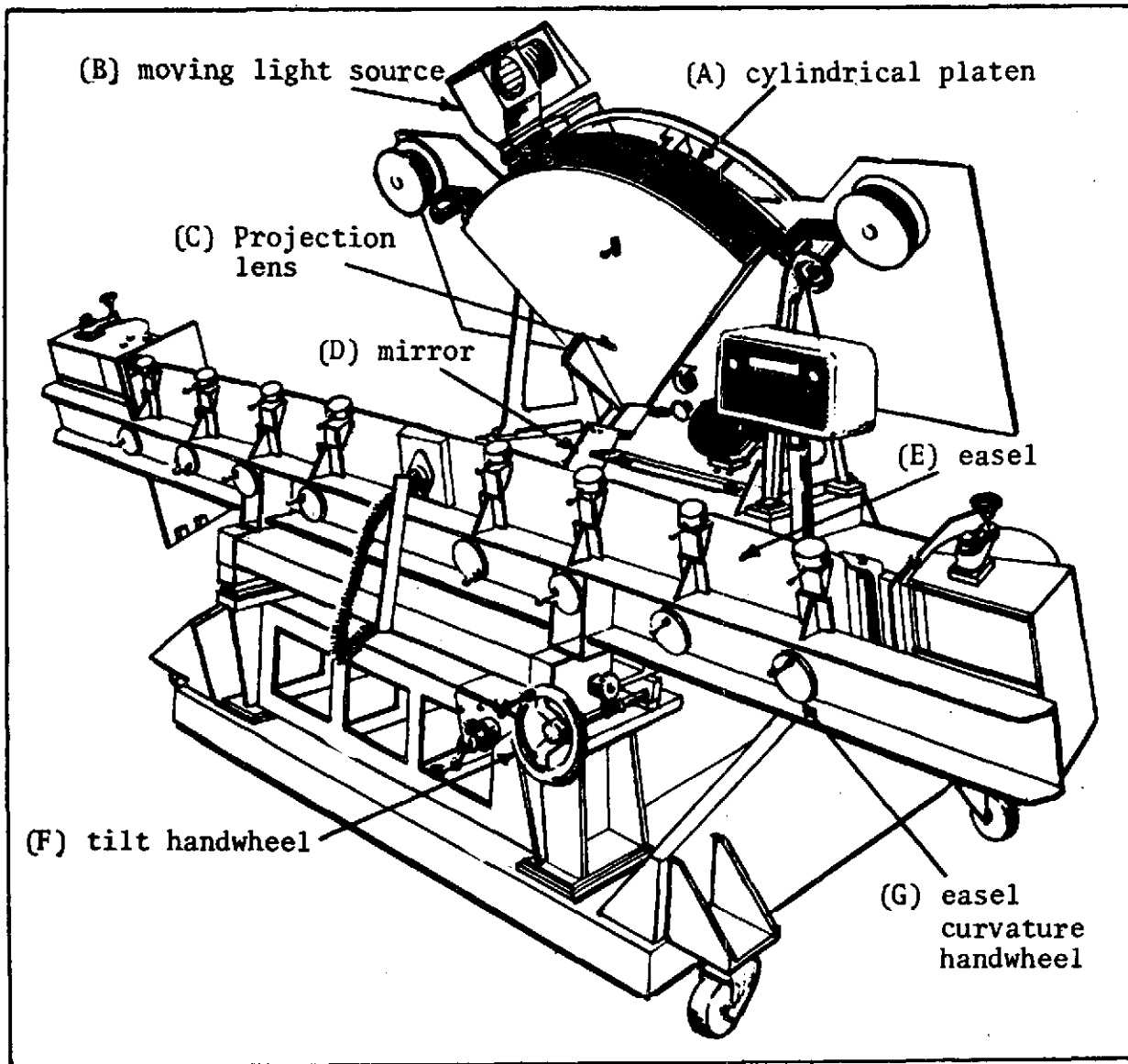

Figure 13. Transforming Printer for Apollo Panoramic Camera Photography

Referring to Figure 13, the panoramic film is carried on a cylindrical platen (A) whose 610-mm (24-in.) radius is equal to the equivalent focal length of the camera. Longitudinal displacement of the film with respect to the center of the arc can compensate for roll of the spacecraft. A moving light source (B), simulating the slit in the panoramic camera, traverses the length of the film in order to make the exposure. A projection lens inside the housing at (C) rotates at a rate which assures sharp focus on the output film (Scheimpflug condition). A mirror at (D) reflects the image to the easel at (E). The handwheel at (F) tilts the entire easel to simulate the 12.5° forward or aft tilt of the camera and any pitch of the spacecraft at the time of the exposure. The small handwheels (G) adjust the longitudinal curvature of the easel to simulate the curvature of the Moon's surface for various orbital altitudes.

Optical characteristics of the projection lens limit the transforming printer to a scan range of $\pm 35^\circ$ from the center although the camera has a range of $\pm 54^\circ$. This means that the entire area of the panoramic photograph can not be transformed. However, the $\pm 35^\circ$ is nearly equal to the cross track coverage of the mapping camera, and photographic passes were planned so that continuous coverage of the lunar surface could be provided by the transformed panoramic photographs.

Figure 14 shows the coverage of the transformed rectified print compared with the actual total area photographed by the panoramic camera. The output picture format is 229 mm x 1803 mm (9 x 71 inches). The nominal magnification at the center of the picture is 2X. Geometric distortion displacement from all causes, except for topographic relief, will not exceed 1 mm. This accuracy is not adequate for photogrammetric mapping without further correction but is more than adequate for stereoscopic viewing and preparation of uncontrolled mosaics. It is important to recognize that the transformed pictures will still have image displacements due to topographic relief in exactly the same way as frame photographs. The optical quality of the transforming printer can maintain the resolution of the input material. However, several additional photographic processing steps are involved, so that the quality of the transformed pictures delivered to the user will be slightly degraded below that of the untransformed panoramic photographs. Transformed pictures in either film or paper print form are obtainable for all Apollo panoramic photographs.

Panoramic Camera Photographic and Supporting Data

A summary of the panoramic camera coverage is given in Table 3. Individual frames can be obtained as 127- x 1219-mm (5- x 48-in.) contact negative or positive film copies or as contact paper prints. Frames should be requested by frame number (e.g., AS17-2686). Individual pan rectified photographs (which have the same frame numbers as the originals) can be obtained as 241- x 2034-mm (9.5- x 80-in.) contact negative or

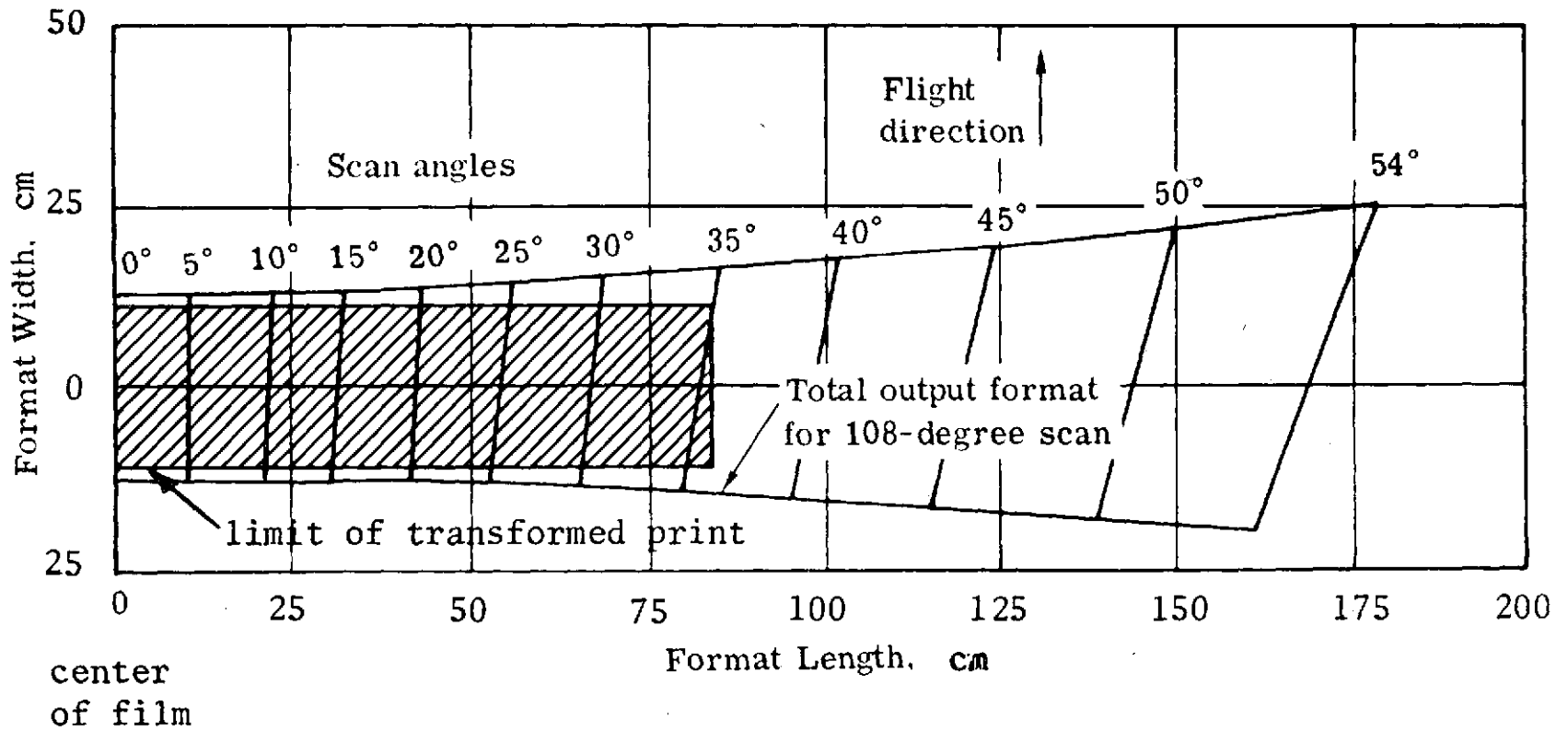

Figure 14. Comparison of Transformed Print to Total Area Photographed

Table 3

Summary of Usable Apollo 17 Panoramic Camera Photographs

REV	MODE	ATTITUDE	NASA PHOTO NOS. AS17-	NO. FRAMES	START		STOP	
					LAT.	LONG.	LAT.	LONG.
1/2	STEREO	VERT	1588-1790	203	19.9S	152.6W	4.2S	143.0E
2	STEREO	VERT	1791-1880	90	3.9N	122.2E	12.1N	93.6E
13/14	STEREO	VERT	1881-2120	240	18.9S	172.1W	7.1N	99.4E
15	STEREO	VERT	2121-2360	240	6.0N	101.6E	19.4N	14.5E
28	STEREO	VERT	2365-2594	230	15.3S	154.4E	8.1N	84.1E
36	MONO	SOUTH OBLIQUE	2595-2599	5	8.5N	64.6E	9.1N	62.2E
49	STEREO	VERT	2600-2768	169	5.4N	79.7E	21.7N	24.9E
62	STEREO	FWD OBLIQUE	2769-2889	121	18.4S	130.7E	4.4S	90.2E
	MONO	VERT	2890-2900	11	17.6N	32.2E	19.3N	25.9E
74	STEREO	VERT	2901-3036	136	0.8N	66.8E	16.6N	24.1E
74	STEREO	VERT	3037-3148	112	22.4N	5.5W	21.9N	43.9W
TEC	MONO	VERT	3152-3168	17	1.3S	114.2E	4.9N	106.1E
			TOTAL	1,574				

Each revolution begins at the 180° meridian. The designation "1/2" in the REV column indicates that the camera was turned on in revolution one and continued in operation across the 180° meridian into revolution two.

positive film transparencies or contact paper prints. Complete rolls, or a complete set of panoramic photography (either original or rectified), can be obtained as contact negative or positive film duplicates or paper prints.

Supporting data for the panoramic camera photographs, on one reel of 16-mm microfilm, are available from NSSDC. A sample of the panoramic camera supporting data is presented in Figure 15. (For an explanation of all items in the figure, see "SIM Bay Photographic Equipment and Mission Summary, Apollo 17 Supplement."³) A complete one-line index for the panoramic camera photography can also be obtained on one reel of 16-mm microfilm. The photography is indexed in two ways: (a) by frame number and (b) by longitude in 10° increments. This reel also contains the indexes for the photography of the mapping, Nikon, Hasselblad, RCA TV, and Maurer cameras. The panoramic camera indexes, together with the mapping camera indexes, may also be obtained as microfiche. Samples of the panoramic camera photography indexes are given in Figures 16 and 17. The supporting data and indexes appropriate to each requested frame will be sent with orders for photography. Requesters ordering large quantities of selected frame reproductions, or the full complement of panoramic camera photography, will be furnished routinely with a 16-mm roll film reproduction of the supporting data and indexes. Requesters who wish to preview the imagery on the panoramic frames can order the complete panoramic photography catalog on one reel of 35-mm microfilm.

COMMAND MODULE PHOTOGRAPHY

The command module photographic tasks were to obtain photographs of:

1. Areas of geological interest.
2. Near-terminator areas, where details of relief are enhanced.
3. Areas not covered by photography from previous missions.
4. Areas in earth-shine (ashen light).
5. Low-light-level astronomical phenomena, such as the solar corona and zodiacal light.
6. Crew option areas on the basis of real-time observations.

The command module photographic equipment included a Hasselblad electric camera (HEC) with 80-mm and 250-mm focal length lenses and a 105-mm focal length ultraviolet lens; a 16-mm Maurer data acquisition camera (DAC) with 10-mm, 18-mm, and 75-mm focal length lenses; a Nikon 35-mm (film) camera, and a Westinghouse color TV camera.

	YEAR	MONTH	DAY	HOUR	MINUTE	SECOND			
	GMT1972	12	14	18	57	50.272			
	CTC		7	13	24	51.897			
STATE VECTOR	X (KM)	Y (KM)	Z (KM)	ROOT (KM/S)			YDOT (KM/S)	ZDOT (KM/S)	
1950.0	-1229.0643109	-1374.2702418	150.1383177	-1.0238049			1.0006541	.7756092	
SELENOGRAPHIC	147311648635	9182281125	643.2583132	.7495852			-1.4191022	.4278720	
LONGITUDE OF NAQIR POINT	31.0032824 DEG			LATITUDE OF NAQIR POINT			20.3433347 DEG		
	31 DEG, 52 MIN, 59.8167229 SEC						20 DEG, 20 MIN, 30.0098299 SEC		
LONG OF CAMERA AXIS INTERSECT	31.0134497 DEG			LATI OF CAMERA AXIS INTERSECT			20.0004000 DEG		
	31 DEG, 0 MIN, 48.4180000 SEC						20 DEG, 30 MIN, 23.0429649 SEC		
SPACECRAFT RADIUS	1850.3314542 KM			SPACECRAFT ALTITUDE			113.2014578 KM		
SCALE FACTOR	.0052977 M/KM			AZIMUTH OF VELOCITY VECTOR			201.2630000 DEG		
MEAN ALTITUDE RATE	.0000196 KM/SEC			HORIZONTAL VELOCITY			1.0279426 KM/SEC		
TILT AZIMUTH	281.4639854 DEG			TILT ANGLE			12.6413121 DEG		
SIGMA TILT AZIMUTH	.0009139 DEG			SIGMA TILT ANGLE			.0002000 DEG		
SUN ELEVATION AT PRIM GRND PNT	46.1539660 DEG			SUN AZIMUTH AT PRINCIPAL GRND PNT			114.8679567 DEG		
LONGITUDE OF SUBSOLAR POINT	70.2551342 DEG			LATITUDE OF SUBSOLAR POINT			-2.2722468 DEG		
	70 DEG, 15 MIN, 18.4830660 SEC						0 DEG, 40 MIN, 45.2877417 SEC		
ALPHA	12.0042357 DEG			SWING ANGLE			209.4991026 DEG		
EMISSION ANGLE	13.4726019 DEG			SIGMA SWING ANGLE			.0009139 DEG		
PHASE ANGLE	30.9317006 DEG			NORTH DEVIATION ANGLE			108.4630007 DEG		
PHI	12.6410776 DEG			R-TILT			-.0774214 DEG		
SIGMA PHI	.0002000 DEG			SIGMA X-TILT			.0002000 DEG		
KAPPA	-168.1987825 DEG			Y-TILT			-12.6410669 DEG		
SIGMA KAPPA	.0002000 DEG			SIGMA Y-TILT			.0002000 DEG		
OMEGA	-.0774214 DEG			HEADING			-70.1734154 DEG		
SIGMA OMEGA	.0002000 DEG			SIGMA HEADING			.0002000 DEG		
SPACECRAFT ALTITUDE (LASER)	.0000000 KM			LASER SLANT RANGE			.0000000 KM		

SELENOGRAPHIC DIRECTION COSINES OF CAMERA AXIS	X	Y	Z	MAGNITUDE (KM)
	-.67641623	-.67334828	-.29843454	115.217382

TRANSFORMATION MATRIX FROM SELENOCENTRIC TO CAMERA

TRANSFORMATION MATRIX FROM LOCAL HORIZONTAL TO CAMERA

.75507789+00	.43444840+00	.49103201+00	-.95504712+00	.19998226+00	.2104266+00
-.41063711+00	.27047496+00	-.87075868+00	-.20466331+00	-.97883361+00	.13514320+00
-.5111159+00	-.05912616+00	-.25928934+01	.21448821+00	-.42496214+00	.97275928+00

PHOTOGRAPH FOOTPRINT

LATITUDE	LONGITUDE	LATITUDE	LONGITUDE
25.797	32.576	23.023	31.940
15.082	30.205	17.841	30.620
14.913	29.231	17.864	30.919
26.253	31.777	23.300	31.189

Figure 15. Sample of Panoramic Camera Supporting Data

REPRODUCIBILITY OF THE ORIGINAL PAGE IS POOR

APOLLO 17
PANORAMIC CAMERA PHOTOGRAPHS

NASA PHOTO AS17-	CAMERA LOOK	STEREO FRAME AS17-	PRINCIPAL POINT		ALT. KM.	REV NO.	SUN EL.	DESCRIPTION
			LAT.	LONG.				
2676	FWD	2681	14.4 N	55.2 E	112	49	69	PICARD, G, CRISES, SEA OF
2678	FWD	2683	14.6 N	54.6 E	112	49	68	PICARD, LICK, E RIM
2680	FWD	2685	14.8 N	53.8 E	112	49	67	LICK, D
2682	FWD	2687	15.0 N	53.2 E	112	49	67	LICK, B, D, PEIRCE
2684	FWD	2689	15.1 N	52.5 E	112	49	66	LICK B, YERKES, PEIRCE, B
2686	FWD	2691	15.3 N	51.9 E	112	49	66	GLAISHER A, YERKES, PEIRCE, B
2688	FWD	2693	15.6 N	51.3 E	112	49	65	GLAISHER A, B, C, YERKES
2690	FWD	2695	15.8 N	50.6 E	112	49	65	GLAISHER, C, E, YERKES E
2692	FWD	2697	16.1 N	50.0 E	112	49	64	GLAISHER, E
2694	FWD	2699	16.3 N	49.4 E	112	49	63	GLAISHER W, PROCLUS P
2696	FWD	2701	16.6 N	48.8 E	112	49	63	GLAISHER W, PROCLUS P, PEIRCE C
2698	FWD	2703	16.8 N	48.2 E	112	49	62	GLAISHER W, TISSERAND A
2700	FWD	2705	17.0 N	47.5 E	112	49	62	TISSERAND, PROCLUS
2702	FWD	2707	17.1 N	46.9 E	112	49	61	TISSERAND, PROCLUS
2704	FWD	2709	17.2 N	46.2 E	112	49	60	TISSERAND, PROCLUS R, MACROBIUS, D
2706	FWD	2711	17.3 N	45.5 E	112	49	60	PROCLUS R, MACROBIUS
2708	FWD	2713	17.5 N	44.9 E	112	49	59	PROCLUS G, MACROBIUS
2710	FWD	2715	17.7 N	44.2 E	112	49	59	PROCLUS A, MACROBIUS
2712	FWD	2717	17.9 N	43.6 E	112	49	58	PROCLUS A, G, MACROBIUS
2714	FWD	2719	18.1 N	42.9 E	112	49	57	PROCLUS A
2716	FWD	2721	18.3 N	42.3 E	112	49	57	LYELL
2718	FWD	2723	18.5 N	41.6 E	112	49	56	LYELL, PROCLUS D
2720	FWD	2725	18.7 N	40.8 E	112	49	56	LYELL, A, FRANZ
2722	FWD	2727	18.9 N	40.1 E	112	49	55	LYELL A, MACROBIUS A, B
2724	FWD	2729	18.9 N	39.6 E	112	49	54	MARALDI M, MACROBIUS A
2726	FWD	2731	19.0 N	38.9 E	112	49	54	MARALDI M
2728	FWD	2733	19.1 N	38.3 E	112	49	53	MARALDI B
2730	FWD	2735	19.3 N	37.5 E	112	49	52	MARALDI B, D
2732	FWD	2737	19.4 N	37.0 E	112	49	52	MARALDI D
2734	FWD	2739	19.6 N	36.4 E	112	49	51	MARALDI A, D, F, ROMER T
2736	FWD	2741	19.8 N	35.8 E	112	49	51	MARALDI, D, F, ROMER, T
2738	FWD	2743	19.9 N	35.1 E	112	49	50	MARALDI, ROMER, K, T
2740	FWD	2745	20.0 N	34.3 E	112	49	49	MARALDI, ROMER, VITRUVIUS A
2742	FWD	2747	20.2 N	33.5 E	112	49	49	ROMER L, R, LITTROW F
2744	FWD	2749	20.3 N	32.9 E	112	49	48	ROMER R, VITRUVIUS, E OF
2746	FWD	2751	20.5 N	32.2 E	112	49	47	VITRUVIUS, LITTROW A, D
2748	FWD	2753	20.7 N	31.7 E	112	49	47	VITRUVIUS, LITTROW, A, D
2750	FWD	2755	20.9 N	30.9 E	112	49	46	LITTROW, APOLLO 17 LANDING SITE
2752	FWD	2757	20.9 N	30.3 E	112	49	46	VITRUVIUS E, E OF, LE MONNIER
2754	FWD	2759	20.9 N	29.6 E	112	49	45	VITRUVIUS E, LE MONNIER

Figure 16. Sample of Panoramic Camera Frame Index
Ordered by Frame Number

APOLLO 17
PANORAMIC CAMERA PHOTOGRAPHS
INDEXED BY LONGITUDE 30 TO 40 E

NASA CAMERA PHOTO AS17-	STEREO LOOK	STEREO FRAME AS17-	PRINCIPAL POINT		ALT. KM.	REV NO.	SUN EL.	DESCRIPTION
			LAT.	LONG.				
2285	FWD	2290	19.7 N	39.9 E	115	15	24	MACROBIUS A, W RIM, LYELL A
2287	FWD	2292	19.7 N	39.1 E	115	15	23	MARALDI M
2289	FWD	2294	19.8 N	38.2 E	115	15	22	ROMER J, N, V
2291	FWD	2296	19.9 N	37.4 E	115	15	21	ROMER J, N, MARALDI B, D
2293	FWD	2298	19.9 N	36.7 E	115	15	21	ROMER, MARALDI B, D
2295	FWD	2300	19.9 N	35.9 E	115	15	20	ROMER, K, T, MARALDI A, D
2297	FWD	2302	20.0 N	35.4 E	114	15	19	ROMER K, MARALDI
2299	FWD	2304	20.0 N	34.6 E	114	15	19	MARALDI, VITRUVIUS A
2301	FWD	2306	20.0 N	33.8 E	114	15	18	VITRUVIUS A, LITTROW F
2303	FWD	2308	20.0 N	33.0 E	114	15	17	VITRUVIUS, E OF
2305	FWD	2310	20.0 N	32.2 E	114	15	17	VITRUVIUS, E RIM
2307	FWD	2312	20.0 N	31.4 E	113	15	16	VITRUVIUS, LITTROW
2309	FWD	2314	20.0 N	30.6 E	113	15	15	APOLLO 17 LANDING SITE
2724	FWD	2729	18.9 N	39.6 E	112	49	54	MARALDI M, MACROBIUS A
2726	FWD	2731	19.0 N	38.9 E	112	49	54	MARALDI M
2728	FWD	2733	19.1 N	38.3 E	112	49	53	MARALDI B
2730	FWD	2735	19.3 N	37.5 E	112	49	52	MARALDI B, D
2732	FWD	2737	19.4 N	37.0 E	112	49	52	MARALDI D
2734	FWD	2739	19.6 N	36.4 E	112	49	51	MARALDI A, D, F, ROMER T
2736	FWD	2741	19.8 N	35.8 E	112	49	51	MARALDI, D, F, ROMER, T
2738	FWD	2743	19.9 N	35.1 E	112	49	50	MARALDI, ROMER K, T
2740	FWD	2745	20.0 N	34.3 E	112	49	49	MARALDI, ROMER, VITRUVIUS A
2742	FWD	2747	20.2 N	33.5 E	112	49	49	ROMER L, R, LITTROW F
2744	FWD	2749	20.3 N	32.9 E	112	49	48	ROMER R, VITRUVIUS, E OF
2746	FWD	2751	20.5 N	32.2 E	112	49	47	VITRUVIUS, LITTROW A, D
2748	FWD	2753	20.7 N	31.7 E	112	49	47	VITRUVIUS, LITTROW, A, D
2750	FWD	2755	20.9 N	30.9 E	112	49	46	LITTROW, APOLLO 17 LANDING SITE
2752	FWD	2757	20.9 N	30.3 E	112	49	46	VITRUVIUS E, E OF, LE MONNIER
2890	VERT		17.6 N	32.2 E	113	62	59	LITTROW F, MARALDI R
2891	VERT		17.8 N	31.5 E	113	62	59	VITRUVIUS
2892	VERT		18.0 N	30.9 E	113	62	58	LITTROW, A, VITRUVIUS
2893	VERT		18.1 N	30.3 E	113	62	57	LITTROW, APOLLO 17 LANDING SITE
2985	FWD	2990	11.6 N	40.0 E	112	74	77	CAUCHY, E RIM, LYELL
2987	FWD	2992	11.8 N	39.5 E	112	74	76	CAUCHY, SCARP, RILLE
2989	FWD	2994	12.0 N	38.8 E	112	74	76	CAUCHY SCARP, RILLE
2991	FWD	2996	12.3 N	38.2 E	112	74	76	CAUCHY SCARP, RILLE
2993	FWD	2998	12.5 N	37.4 E	112	74	75	CAUCHY SCARP, RILLE
2995	FWD	3000	12.7 N	36.8 E	112	74	75	MARALDI D, E OF
2997	FWD	3002	12.8 N	36.3 E	112	74	74	MARALDI D
2999	FWD	3004	13.0 N	35.6 E	112	74	74	MARALDI D

Figure 17. Sample of Panoramic Camera Frame Index Ordered by Longitude in 10° Increments

Command Module Hasselblad Electric Camera (HEC)

CM Hasselblad Camera Operation and Photography

The command module 70-mm Hasselblad electric camera (HEC) photographs total 1170 frames. Some of the photography taken near Earth covers parts of the Earth not in sunlight on other missions and includes Antarctica, with a spectacular group of photographs across the Atlantic Ocean, Africa, the Indian Ocean, and Australia, some of which emphasize cloud patterns. These photographs of Earth should be ordered from the Technology Application Center (TAC), University of New Mexico, Albuquerque, New Mexico 87106 or U.S. Department of the Interior, Geological Survey, Earth Resources Observation Systems (EROS) Data Center, Sioux Falls, South Dakota 57198.

In the vicinity of the Moon, the HEC was used to photograph the Taurus-Littrow landing site as it lay near the terminator under low-angle illumination. It also was used to document the area north of the groundtrack from Galois (15°S, 152°W) to Vil'ev (6°S, 144°E). Stereo strips were taken on some revolutions, as well as a color sequence from the Apennine mountains across Mare Imbrium. Crew-option photographs include the flash areas (places where the astronauts observed flashes of light on the lunar surface, e.g., in Grimaldi), lunar surface color boundaries, areas with orange-colored strata, flows, and other features of geologic interest. Several crew-option photographs were also taken in the first revolutions around the Moon, prior to landing. The quality of the photography is generally good.

CM Hasselblad Camera Photographic and Supporting Data

NSSDC has for distribution 3232 usable Hasselblad frames out of a total of 3584. Table 4 gives the summary of Hasselblad photography from the Apollo 17 mission. The table distinguishes between orbital and surface photography and designates film types. Note that SO-368 color reproductions in the form of positive film or paper prints in user-specified format can be obtained only by persons performing specific detailed scientific investigations. The image area for all Hasselblad film is 52 x 52 mm. All frames are available as B/W contact negatives or positive film copies on 101- x 127-mm (4- x 5-in.) film sheets or as enlarged 203- x 254-mm (8- x 10-in.) prints. Enlargements in other sizes can be produced upon request. Complete magazines or complete sets of Hasselblad photography can be obtained in B/W as positive or negative contact film duplicates on 70-mm roll film or as positive contact paper prints on 70-mm roll paper. Data can be ordered by individual frame, magazine, or complete set. Requests should be identified precisely, i.e., Apollo 17 Hasselblad color frame AS17-134-20378. A photographic catalog from which a user can select desired frames is available on two reels of 16-mm microfilm or in two microfiche versions (see page 14). The ultraviolet photography is still proprietary and will be announced when it becomes available.

Table 4
Summary of Apollo 17 Hasselblad 70-mm Film Magazines

Mag.	NASA Photo Nos. AS17-	Lens (mm)	Surface	Number of Photos		Total	Film Type
				Orbit	Other		
J	133-20193 20375	60	182		1 Blank	183	3401
B	134-20376 20532	60	154		3 Blank	157	S0-368
G	135-20533 20679	60	146		1 Blank	147	3401
H	136-20680 20865	60	183		3 Blank	186	3401
C	137-20866 21027	60	162			162	S0-368
I	138-21028 21184	60	155		2 Blank	157	3401
K	139-21185 21350	60, 250 500	80	74	12 Blank	166	3401
E	140-21351 21509	60	158		1 Blank	159	S0-368
L	141-21510 21668	60	158		1 Blank	159	3401
M	142-21669 21833	60	163		2 Blank	165	3401
N	143-21834 21982	60	149			149	3401
R	144-21983 22132	500	144		6 Blank	150	3401
D	145-22133 22288	60	96	60		156	S0-368

Table 4

Summary of Apollo 17 Hasselblad 70-mm Film Magazines (concluded)

Mag.	NASA Photo Nos. AS17-	Lens (mm)	Surface	Number of Photos		Total	Film Type
				Orbit	Other		
F	146-22289 22450	60	162			162	S0-368
A	147-22451 22606	60	138	18		156	S0-368
NN	148-22607 22775	80, 250		10	64 E0 92 TLC 3 Blank	169	S0-368
KK	149-22776 22941	80, 250		161	3 TLC 2 Blank	166	S0-368
LL	150-22942 23105	80, 250		164		164	S0-368
OO	151-23106 23269	80, 250		161	3 Blank	164	S0-368
PP	152-23270 23420	80, 250		18	130 Tec 3 Blank	151	S0-368
MM	153-23421 23593	80, 250		170	3 Blank	173	S0-368
QQ	154-23594 23689	80, 250		85	5 TLC 6 Blank	96	2485
RR	155-23690 23776	80, 250		81	6 Blank	87	2485
		TOTALS	2230	1002	352	3584	

NSSDC has available one-line indexes for the Hasselblad photography on one reel of 16-mm microfilm and on microfiche. These indexes are arranged in two ways: (a) by frame number and (b) by longitude in 10° increments. (The latter incorporates the Nikon photography also.) Samples of these indexes are given in Figures 18 and 19, respectively. They are included on the 16-mm reel containing indexes of the photography of the mapping, panoramic, Nikon, RCA TV, and Maurer cameras. These indexes will be provided routinely with requests for a complete set, complete magazines, or a large number of selected photographs. Otherwise, paper copies of pages containing data corresponding to the individual frames requested will be provided. The microfiche contain the Hasselblad, Nikon, and Maurer camera indexes.

Command Module Maurer Camera

CM Maurer Camera Operation and Photography

The 16-mm Maurer data acquisition camera (DAC) documented spacecraft maneuvers and experiment operations and performed landmark tracking tasks. For the latter, the DAC was mounted on the sextant and used during revolution 50. During translunar coast (TLC), the DAC was also used for recording photographs of Earth and its cloud patterns and the jettisoning and departure of the SIM bay door. During transearth coast (TEC), the DAC was used to photograph the CMP during his EVA. During reentry it recorded the fireball accompanying the CM and the deployment of the drogue and the main parachutes. Twelve magazines were exposed from the CM Maurer camera. Three of these are not available from NSSDC.

CM Maurer Camera Photographic and Supporting Data

The Maurer photography (16-mm movie film) is available on a 500-m (1600-ft) reel of color film. NSSDC has removed the cabin and Earth-looking footage from the Maurer coverage, and this is deposited with the Technology Application Center (TAC), University of New Mexico, Albuquerque, New Mexico 87106 and U.S. Department of the Interior, Geological Survey, Earth Resources Observation Systems (EROS) Data Center, Sioux Falls, South Dakota 57198. Since the films primarily provide photography that is supplementary to sample documentation, experiment deployment, and operation, they are not recommended for classroom or general interest purposes. NSSDC can supply the films on a 3-month loan basis to support scientific investigations. Special arrangements may be made for those who require permanent retention. A sample of the Johnson Space Center (JSC) index, arranged alphabetically, is given in Figure 20, and the NSSDC rearrangement of all the magazines in chronological sequence is given in Figure 21. The JSC index will be provided routinely on 16-mm microfilm with all requests for Maurer photography. The complete index, by magazine, for the Maurer camera photography is also available on microfiche.

APOLLO 17
HASSELBLAD 70-MM (FILM WIDTH) PHOTOGRAPHS
MAGAZINE A (AS17-147) FILM TYPE SO-368

NASA PHOTO NO. AS17-147	PRINCIPAL POINT		CAMERA		ALT. KM.	LENS MM.	SUN EL.	MISSION ACTIVITY	DESCRIPTION
	LAT.	LONG.	TILT	AZ					
22451						60		REV 12	CSM VIEWED FROM LM
22452						60		REV 12	CSM VIEWED FROM LM
22453	0.7 S	124.2 E		359	80	60	73	REV 12	CSM VIEWED FROM LM, BECVAR, NW WALL
22454	0.1 S	122.6 E	2	358	80	60	75	REV 12	CSM VIEWED FROM LM, BECVAR, W OF
22455	0.7 N	121.6 E	12	7	78	60	76	REV 12	CSM VIEWED FROM LM, BECVAR, W OF
22456	1.2 N	120.3 E	12	5	76	60	77	REV 12	CSM VIEWED FROM LM, BECVAR, W OF
22457	2.5 N	117.1 E	21	335	74	60	80	REV 12	CSM VIEWED FROM LM, ABUL WAPA, N WALL
22458	2.6 N	115.6 E	8	333	74	60	81	REV 12	CSM VIEWED FROM LM, ABUL WAPA, NW WALL
22459	2.9 N	114.1 E	7	301	72	60	82	REV 12	CSM VIEWED FROM LM, FIRSOV, SE OF
22460	3.7 N	112.1 E	8	311	70	60	84	REV 12	CSM VIEWED FROM LM, FIRSOV, S WALL
22461	4.2 N	110.3 E	6	276	69	60	84	REV 12	CSM VIEWED FROM LM, FIRSOV, W OF
22462	4.7 N	108.4 E	12	276	67	60	84	REV 12	CSM VIEWED FROM LM, FIRSOV, W OF
22463	19.4 N	50.5 E	67	282	31	60	31	REV 12	CSM VIEWED FROM LM, PEIRCE C
22464	20.3 N	30.3 E	60	275	26	60	12	REV 12	CSM, APOLLO 17 LANDING SITE
22465	20.4 N	30.2 E	69	277	26	60	12	REV 12	CSM, APOLLO 17 LANDING SITE
22466	20.4 N	29.9 E	68	277	26	60	12	REV 12	CSM, APOLLO 17 LANDING SITE
22467	20.3 N	20.1 E	68	275	26	60	12	REV 12	CSM, APOLLO 17 LANDING SITE

Figure 18. Sample of Orbital Hasselblad Camera Frame
Index Ordered by Frame Number

APOLLO 17
HASSELBLAD (70-MM) AND NIKON (35-MM) PHOTOGRAPHS
INDEXED BY LONGITUDE 30 - 40 E

NASA PHOTO NO. AS17-	MAG.	FILM TYPE	REV	ALT. KM.	SUN EL.	LENS M.	CAMERA		PRINCIPAL POINT		DESCRIPTION
							TILT	AZ	LAT.	LONG.	
139-21277	K	3401	62	112	57	60	68	298	20.4 N	31.6 E	MARALDI, APOLLO 17 LANDING SITE
139-21278	K	3401	62	112	57	60	65	301	20.6 N	30.8 E	MARALDI, APOLLO 17 LANDING SITE
139-21279	K	3401	62	112	57	60	59	303	20.0 N	30.8 E	MARALDI, APOLLO 17 LANDING SITE
139-21280	K	3401	62	112	57	60	54	308	20.0 N	31.0 E	VITRUVIUS, APOLLO 17 LANDING SITE
139-21281	K	3401	62	112	57	60	47	319	20.2 N	31.1 E	VITRUVIUS, APOLLO 17 LANDING SITE
139-21282	K	3401	62	113	57	60	33	6	20.4 N	30.8 E	LITTRAW, APOLLO 17 LANDING SITE
139-21312	K	3401	73	112	78	60	31	210	9.4 N	39.7 E	CAUCHY, TRANQUILITY, SEA OF
139-21313	K	3401	73	112	77	60	29	206	9.8 N	39.0 E	CAUCHY, TRANQUILITY, SEA OF
139-21314	K	3401	73	112	77	60	31	217	10.0 N	38.1 E	CAUCHY, TRANQUILITY, SEA OF
139-21315	K	3401	73	112	76	60	34	225	10.2 N	37.0 E	CAUCHY, TRANQUILITY, SEA OF
139-21316	K	3401	73	112	75	60	38	230	10.2 N	36.2 E	CAUCHY SCARP, TRANQUILITY, SEA OF
139-21317	K	3401	73	112	74	60	36	228	10.7 N	35.3 E	CAUCHY SCARP, TRANQUILITY, SEA OF
139-21318	K	3401	73	112	75	60	17	182	11.4 N	37.4 E	CAUCHY A, TRANQUILITY, SEA OF
139-21319	K	3401	73	112	75	60	13	182	11.8 N	37.0 E	CAUCHY A, TRANQUILITY, SEA OF
139-21320	K	3401	73	112	74	60	82	225	10.6 N	34.7 E	SINAS, TRANQUILITY, SEA OF

Figure 19. Sample of Hasselblad and Nikon Cameras Frame
Index Ordered by Longitude in 10° Increments

APOLLO 17

INDEX OF 16-MM FILM STRIPS

MAG.	FILM	LENS F/L (mm)	FRAMES Per Sec	DESCRIPTION
II	SO-368	10	6	CM/LM interior, crew activity; TLC.
JJ				Not used.
O	SO-368	10	12	Undocking, CSM and lunar surface viewed from LM: Strip begins east oblique panning to vertical (from approx. 4° South, 134° East to 5° North, 108.5° East). Includes Craters Ten Bruggencate, Prager, Becvar, Abul Wafa and Firsov. REV 12.
		10	12	CSM and lunar surface viewed from LM. West oblique view over Apollo 17 landing site. REV 12.
P	SO-368	10	6	LM on lunar surface, view from right side (LMP) window. CDR on lunar surface; surface familiarization; activity around Modular Equipment Stowage Assembly (MESA).
Q	SO-368	10	12	LM ascent. LM shadow and jettisoned equipment bags on lunar surface; LM ascent stage shadow, LM descent stage, ALSEP, LRV, and tracks at landing site. Lincoln scarp, North Massif, Family Mountain, westward into Sea of Serenity. Sequence ends SW of Le Monnier C (25.8°E, 21.5°N), CM REV 51.
		10	12	LM Intravehicular activity.

Figure 20. Sample of Maurer Camera Film Index

<u>Magazine</u>	<u>Description</u>
O	East limb highlands and site obliques, undocking
BB	Sextant TLC photography, landmark tracking
EE	LM descent and landing site from orbit
P	Surface after landing, first EVA
Q	LM liftoff, landing site and Mare Serenitatis
CC	Separation and undocking and full lunar disk, post TEI
DD	Lunar surface, LM jettison and post TEI
FF	Command pilot EVA during TEC
GG	Reentry and Earth's horizon
<hr/>	
AA*	Earth from TLI and SIV-B
HH*	Cabin interior and heat flow experiment in zero gravity
II*	Cabin interior, eating period
JJ*	Not used

*Not at NSSDC; available from TAC or EROS.

Figure 21. NSSDC Maurer Camera Photography Index
Ordered Chronologically

Nikon Camera

Nikon Camera Operation and Photography

The 35-mm (film) Nikon camera, with a focal length of 55 mm and a relative aperture of 46 mm (or an f-ratio of 1.2) was designed for through-the-lens viewing and metering. A very high-speed black and white (VHBW) film, 2485, was used for the Nikon photography. The Command Module pilot (CMP) operated the camera manually when targets of interest were in view. The mission objectives for this camera included dim light photography of the earth-lit (ashen light) portions of the Moon, the solar corona, and the zodiacal light. Analysis of the extent, locations, configurations, and light levels of astronomical sources can provide information on the location of interplanetary and interstellar concentrations of matter. Nikon earthshine photographs include craters Eratosthenes, Copernicus, Grimaldi, and Riccioli, the peculiar feature Reiner γ , and Mare Orientale. Photographs of the nearside and farside near-terminator areas were also obtained as well as areas of interest designated by the CMP.

Nikon Camera Photographic and Supporting Data

Table 5 is a summary of the Nikon photography (approximately 400 frames) that was taken during the Apollo 17 mission. NSSDC can provide the available frames in the form of negative or positive copies on 35-mm roll film. Individual frames can be provided in the form of 203- x 254-mm (8- x 10-in.) paper print enlargements, 83- x 102-mm (3.25- x 4-in.) lantern slides, or 51- x 51-mm (2- x 2-in.) slides. Figure 22 is a sample page of the Nikon photography index by frame number. Figure 19 is a sample of the Nikon and Hasselblad photography indexed by longitude in 10° increments. The index will be provided routinely on 16-mm microfilm when a large number of individual photographs, a complete set of photography, or complete magazines are requested. The index is also available on microfiche. The principal investigator, R. Mercer, has supplied an index to the Nikon photography which provides additional information. A sample of this index is shown in Figure 23. This index is included on the 16-mm microfilm roll that contains all the indexes of Apollo 17 photography.

Westinghouse TV Camera

The Westinghouse TV camera in the Command Module could be handheld or bracket-mounted. This camera was operated at variable f-stops from 4 to 44, using a zoom lens. A 5-cm black and white video monitor, which could be mounted on the camera or at various locations within the CM, aided the crew in focus and exposure adjustments. A camera ring sight also enabled the crew to direct the camera lens at the desired target.

Table 5
 Summary of Apollo 17 Nikon 35-mm Film Magazines

Mag.	NASA Photo Nos. AS17-	Lens mm	Number of Photos			Total	Film Type
			Surface	Orbit	Other		
UU	156-23777 23816	55			40 Gray Scale	40	2485
VV	157-23817 23862F	55		42	9 TEC 1 Blank	52	2485
WW	158-23863 23903	55		41		41	2485
XX	159-23904 23945	55		39	3 Blank	42	2485
YY	160-23946 23997	55		49	3 Blank	52	2485
ZZ	161-23998 24034	55		18	18 Gray Scale 1 Blank	37	2485
SS	162-24035 24106	55		6	64 TLC 2 Blank	72	S0168
TT	163-24107 24180	55			72 TEC 2 Blank	74	S0168
TOTALS				195	215	410	

APOLLO 17
 NIKON 35-MM (FILM WIDTH) PHOTOGRAPHS
 MAGAZINE VV (AS17-157) FILM TYPE 2485

NASA PHOTO NO. AS17- 157	PRINCIPAL POINT		CAMERA		ALT. KM.	LENS MM.	SUN EL.	MISSION ACTIVITY	DESCRIPTION
	LAT.	LONG.	TILT	AZ					
23817						55		TEC	CM INTERIOR
23818						55		TEC	CM INTERIOR, SCHMITT
23819						55		TEC	CM INTERIOR, SCHMITT
23820						55		TEC	CM INTERIOR, CERNAN
23821						55		TEC	CM INTERIOR, EVANS
23822						55		TEC	CM INTERIOR, CERNAN
23823						55		TEC	CM INTERIOR, EVANS
23824						55		TEC	CM INTERIOR, EVANS
23825									BLANK
23826	40.6 S	119.3 E		192		55		TEC	PIZZETTI, CLARK, VAN DER WAALS
23827	17.3 S	119.5 E	54	296	111	55	15	REV 74	DELPORTE, SW OF
23828	12.1 S	120.8 E	63	331	111	55	14	REV 74	DANJON
23829	12.6 S	124.5 E	60	352	111	55	11	REV 74	DELPORTE, N WALL, LANGEMAK
23830	19.4 S	122.0 E	45	278	111	55	13	REV 74	FERMI
23831	16.2 S	125.3 E	46	343	111	55	10	REV 74	FERMI, N WALL
23832	16.9 S	124.0 E	47	319	111	55	11	REV 74	FERMI, LUTKE, DELPORTE
23833	18.0 S	122.6 E	52	295	111	55	12	REV 74	FERMI, LUTKE, DELPORTE
23834	20.0 S	124.0 E	43	275	111	55	11	REV 74	FERMI
23835	19.3 S	124.0 E	47	286	111	55	11	REV 74	FERMI
23836	16.3 S	127.7 E	47	346	111	55	8	REV 74	TSIOLKOVSKY, N OF
23837	19.6 S	128.2 E	21	318	111	55	7	REV 74	TSIOLKOVSKY, N WALL
23838	18.7 S	127.7 E	36	317	111	55	8	REV 74	TSIOLKOVSKY
23839	17.9 S	124.4 E	56	297	111	55	11	REV 74	FERMI, LUTKE, DELPORTE
23840	18.8 S	130.0 E	30	340	111	55	5	REV 74	TSIOLKOVSKY
23841	19.5 S	128.9 E	35	298	111	55	6	REV 74	TSIOLKOVSKY

Figure 22. Sample of Nikon Photography Index
 Ordered by Frame Number

Film Type 2485

Film Size 35 mm

Quick Look Fr. No.	NASA Frame No.	Subject	Time of Exposure		Exp. Time (sec)	CENTER FRM LOC		CORNER FRM LOC		Remarks	
			Date	GNE		RT	ASC	RT	ASC		
						LONG	LAT	LONG	LAT		
1	23946	Eratothenes					6.5°W	14.5°N	6.5°W	17.5°N	Marco Polo C
2	23947	Timocharis					10.5°W	25.0°N	6.5°W	26.0°N	
3	23948	Beijerick					153.0°E	15.0°S	156.0°E	16.5°S	Gagarin on right edge
4	23949	Agassiz					148.0°E	17.5°S	151.0°E	17.0°S	
5	23950	Jules Verne					147.0°E	25.0°S	143.0°E	36.0°S	Pavlov in background
6	23951	Jules Verne					148.5°E	26.0°S	151.0°E	41.0°S	Pavlov at upper R.H. edge
7	23952	Protect Frame	14 Dec '72	-	1/1000						
8	23953	Zodiacal Light, Polaroid	14 Dec '72	1953	90		21 ^h 45 ^m	-12°	22 ^h 55 ^m	+2°	
9	23954	Zodiacal Light, Polaroid	14 Dec '72	1955	90		21 ^h 15 ^m	-15°	22 ^h 10 ^m	+3°	
10	23955	Zodiacal Light, Polaroid	14 Dec '72	1957	60		20 ^h 50 ^m	-18°	21 ^h 55 ^m	-4°	
11	23956	Zodiacal Light, Polaroid	14 Dec '72	1959	60		20 ^h 35 ^m	-18°	21 ^h 35 ^m	-3°	
12	23957	Zodiacal Light, Polaroid	14 Dec '72	2000	30		20 ^h 15 ^m	-19°	21 ^h 30 ^m	-3°	
13	23958	Zodiacal Light, Polaroid	14 Dec '72	2001	30		20 ^h 05 ^m	-20°	21 ^h 20 ^m	-1°	
14	23959	Zodiacal Light, Polaroid	14 Dec '72	2002	20		19 ^h 50 ^m	-21°	20 ^h 55 ^m	-4°	Bright Object - Jupiter
15	23960	Zodiacal Light, Polaroid	14 Dec '72	2003	20		19 ^h 45 ^m	-20°	20 ^h 55 ^m	-4°	Bright Object - Jupiter
16	23961	Zodiacal Light, Polaroid	14 Dec '72	2004	10		19 ^h 35 ^m	-21°	20 ^h 45 ^m	-2°	Bright Object - Jupiter
17	23962	Zodiacal Light, Polaroid	14 Dec '72	2004	10		19 ^h 25 ^m	-21°	20 ^h 40 ^m	-5°	Bright Object - Jupiter
18	23963	Zodiacal Light, Polaroid	14 Dec '72	2005	5		19 ^h 15 ^m	-21°	20 ^h 05 ^m	-7°	Bright Object - Jupiter
19	23964	Zodiacal Light, Polaroid	14 Dec '72	2006	5		19 ^h 15 ^m	-21°	20 ^h 15 ^m	-4°	Bright Object - Jupiter
20	23965	Zodiacal Light, Polaroid	14 Dec '72	2006	3		19 ^h 10 ^m	-21°	20 ^h 00 ^m	-4°	Bright Object - Jupiter
21	23966	Zodiacal Light, Polaroid	14 Dec '72	2006	3		19 ^h 10 ^m	-21°	20 ^h 00 ^m	-4°	Bright Object - Jupiter
22	23967	Zodiacal Light, Polaroid	14 Dec '72	2006	1		19 ^h 05 ^m	-21°	20 ^h 00 ^m	-4°	Bright Object - Jupiter
23	23968	Zodiacal Light, Polaroid	14 Dec '72	2006	1		19 ^h 00 ^m	-21°	20 ^h 00 ^m	-4°	Bright Object - Jupiter
24	23969	Zodiacal Light, Polaroid	14 Dec '72	2007	1/4		19 ^h 00 ^m	-21°	20 ^h 00 ^m	-4°	Bright Object - Jupiter
25	23970	Zodiacal Light, Polaroid	14 Dec '72	2007	1/4		19 ^h 00 ^m	-21°	20 ^h 00 ^m	-4°	Bright Object - Jupiter
26	23971	Zodiacal Light, Polaroid	14 Dec '72	2007	1/15		19 ^h 00 ^m	-21°	20 ^h 00 ^m	-4°	Bright Object - Jupiter
27	23972	Zodiacal Light, Polaroid	14 Dec '72	2007	1/15		18 ^h 55 ^m	-21°	19 ^h 55 ^m	-4°	Bright Object - Jupiter
28	23973	Zodiacal Light, Polaroid	14 Dec '72	2007	1/60		18 ^h 55 ^m	-21°	19 ^h 55 ^m	-4°	Bright Object - Jupiter
29	23974	Zodiacal Light, Polaroid	14 Dec '72	2007	1/60		18 ^h 55 ^m	-21°	19 ^h 55 ^m	-4°	Bright Object - Jupiter
30	23975	Protect Frame	14 Dec '72	2007	1/1000						
31	23976	Jules Verne					146.5°E	27.5°S	143.0°E	24.5°S	Jules Verne and Pavlov
32	23977	Jules Verne					143.5°E	25.5°S	141.0°E	23.0°S	Pavlov lower L.N. corner
33	23978	Agassiz					144.5°E	17.5°S	153.0°E	11.0°S	
34	23979	Lambert					21.5°W	24.0°N	21.0°W	26.0°N	
35	23980	Euler					31.0°W	24.0°N	28.0°W	27.0°N	
36	23981	Euler Hills					29.0°W	10.0°N	25.0°W	10.0°N	Tobias Mayer
37	23982	Euler Hills					30.0°W	17.0°N	30.0°W	20.0°N	Tobias Mayer
38	23983	Euler Hills					31.0°W	20.5°N	29.5°W	23.0°N	Euler P near center

Figure 23. Sample Page of the Index to the Nikon Photography
as Supplied by the Principal Investigator

The scanning rate for the Westinghouse TV camera was the commercial 30 fps, 525 scan lines/frame. Scan conversion for black and white monitors was not required. The effective resolution of the camera was 200 TV lines/picture height (limited by S-band equipment) with an aspect ratio of 4:3 and a range of operation from 5 to 12,000 f-c. Color was achieved by using a rotating disk driven by a synchronous 600-rpm motor.

The imagery from the Westinghouse TV camera is deposited at NSSDC and is included with the RCA TV footage described on page 46. The Westinghouse TV camera was used primarily for orbital cabin interior activities, docking, undocking, and TEC EVA activities, much of which was displayed on commercial TV during the mission.

LUNAR SURFACE AND LUNAR MODULE PHOTOGRAPHY

The lunar surface and Lunar Module photographic tasks were to obtain:

1. Documentary metric and stereo photographs of emplaced experiments and their operation.
2. Documentary metric and stereo photographs of collected samples and surrounding areas.
3. Full 360° panoramas of the landing site area.
4. Motion picture photographs of the Lunar Roving Vehicle.
5. Lunar Module descent and ascent sequence photographs.

Carried on the Lunar Module were three Hasselblad electric data cameras (HEDC), one 16-mm Maurer data acquisition camera, and an RCA color TV camera.

Lunar Module Hasselblad Electric Data Cameras (HEDC)

LM Hasselblad Electric Data Camera Operation and Photography

The Lunar Module carried three Hasselblad electric data cameras, two with 60-mm focal length lenses and one with a 500-mm focal length lens. Each of the cameras had a reseau plate which provided metric capability. The 60-mm cameras could be handheld in the LM or bracket-mounted on the astronauts' environmental control unit for EVA photography. The 60-mm cameras were used for photography through the LM window and for photography of surface activities, sample sites, deployed ALSEP instruments, and the LRV tracks. These cameras exposed pictures both in color and in black and white. The 500-mm camera, which used black and white film, was used to photograph distant objects from

selected points during three EVA periods. Photography from this camera covers scenes including North and South Massifs, Sculptured Hills, Shorty, Van Serg, other craters visited on the EVAs, Lincoln scarp, and the Taurus-Littrow valley floor.

Hasselblad Electric Data Camera Photographic and Supporting Data

The LM Hasselblad cameras exposed about 2230 frames. Table 4 on page 33 gives a summary of all Apollo 17 Hasselblad photography, both orbital and surface, on color and B/W film. As in the case of CM Hasselblad photography, individual black and white photographs, with an image area of 52 x 52 mm on the 70-mm film, can be produced as contact positive or negative film copies on 101- x 127-mm (4- x 5-in.) film sheets or as enlarged 203- x 254-mm (8- x 10-in.) prints. Enlargements in other format sizes can be prepared upon request. Complete magazines or complete sets of Hasselblad photography can be produced in B/W as positive or negative contact film duplicates (70-mm roll film) or as positive contact paper prints (70-mm roll paper). Color reproductions in the form of positive or negative film copies, or as enlarged paper prints in a user-specified format, will be provided only to those persons performing specific detailed scientific investigations. Requesters should specify complete frame numbers, e.g., AS17-134-20378, for all photographs requested. A photographic catalog of all Apollo 17 Hasselblad photography is available from NSSDC on two reels of 16-mm microfilm or in two microfiche versions (see page 14).

A sample of the index for surface activity is given in Figure 24. The indexes will be provided routinely on one reel of 16-mm microfilm when a large number of individual photographs, a complete set of photography, or complete magazines are requested. Paper copies of the index will be provided with selected individual frames. The Hasselblad and Maurer indexes are also available on microfiche. More complete supporting data will not be available.

Lunar Module Maurer Camera

One 16-mm Maurer camera with 10-mm focal length lens was carried in the Lunar Module. It was mounted in the LM right-hand window and recorded low-altitude views of the landing site, landing site views during descent and ascent, the maneuvers with the CSM and intravehicular activity, the deployed ALSEP instruments, and the LRV tracks.

All 16-mm Maurer film is available as 16-mm color film duplicates. NSSDC has nine magazines on one reel. It should be noted that the LM Maurer films as well as the CM Maurer films are not recommended for classroom or general use. NSSDC can supply the films on a 3-month loan basis to support scientific investigations. Special arrangements may be made for those who require permanent retention. A chronological index to the LM and CM Maurer photography is given in Figure 21 on page 38.

APOLLO 17
 HASSELBLAD 70-MM (FILM WIDTH) PHOTOGRAPHS
 LUNAR SURFACE - CHRONOLOGICAL LISTING

NASA PHOTO NO. AS17-	MAG.	FILM TYPE	SUN EL.	LENS MM.	EVA	DESCRIPTION
139-21190	K	3401	37	500	3	STA 6. N MASSIF
139-21191	K	3401	37	500	3	STA 6. N MASSIF
139-21192	K	3401	37	500	3	STA 6. N MASSIF
139-21193	K	3401	37	500	3	STA 6. N MASSIF
139-21194	K	3401	37	500	3	STA 6. TOWARD STA 3
139-21196	K	3401	37	500	3	STA 6. TOWARD STA 3
139-21197	K	3401	37	500	3	STA 6. TOWARD STA 2
139-21198	K	3401	37	500	3	STA 6. TOWARD STA 2
139-21199	K	3401	37	500	3	STA 6. TOWARD STA 2
139-21200	K	3401	37	500	3	STA 6. TOWARD STA 2
139-21201	K	3401	37	500	3	STA 6. TOWARD STA 2
139-21202	K	3401	37	500	3	STA 6. TOWARD STA 2
139-21203	K	3401	37	500	3	STA 6. LM
139-21204	K	3401	37	500	3	STA 6. LM
139-21205	K	3401	37	500	3	STA 6. LM
139-21206	K	3401	37	500	3	STA 6. TOWARD STA 3
139-21207	K	3401	37	500	3	STA 6. TOWARD STA 3
139-21208	K	3401	37	500	3	STA 6. S MASSIF
139-21209	K	3401	37	500	3	STA 6. S MASSIF
139-21210	K	3401	37	500	3	STA 6. S MASSIF
139-21211	K	3401	37	500	3	STA 6. S MASSIF
146-22296	F	SO-368	37	60	3	STA 6. LRV, LMP
146-22297	F	SO-368	37	60	3	STA 6. LRV, LMP
141-21628	L	3401	37	60	3	STA 6. BOULDER CLOSEUP
141-21629	L	3401	37	60	3	STA 6. BOULDER CLOSEUP

Figure 24. Sample of Surface Hasselblad Camera Frame Index
 Ordered Chronologically Indicating Activity

RCA TV Camera

The Lunar Module carried an RCA TV camera that could be mounted on the LM Modularized Equipment Storage Assembly (MESA), set up on a tripod, or installed on the LRV. In addition to the crew's being able to aim and control the camera, personnel at the Mission Control Center could activate the camera "on" and "off," control the pan, tilt, zoom, iris open/close (f/2.2 to f/22), and peak or average light control functions.

The scanning rate for the RCA TV camera was the commercial 30 fps, 525 scan lines/frame. Scan conversion for black and white monitors was not required. The effective resolution of the camera was 200 TV lines/picture height (limited by S-band equipment) with an aspect ratio of 4:3 and a range of operation from 5 to 12,000 f-c. Color was achieved by using a rotating disk driven by a synchronous 600-rpm motor.

All of the TV coverage was recorded on black and white 16-mm kinescope roll film. Both Westinghouse and RCA TV coverage are stored at NSSDC. The coverage totals 38 cans that take approximately 22 hours running time. All of this film or specified parts of it should be ordered by the MSC reel number given in Table 6. These data can be obtained on a 3-month loan basis, or special arrangements can be made for permanent retention. Table 6 is a summary of the TV coverage available.

Table 6

NSSDC Summary of Apollo 17 TV Kinescope Film Log

MSC FILM IDENT. NO.	GMT DAY/HR:MIN	COVERAGE
S - 72 - 351	347/0107 - 0139	EVA 1
S - 72 - 352	347/0139 - 0218	EVA 1
S - 72 - 353	347/0246 - 0321	EVA 1
S - 72 - 354	347/0320 - 0331	EVA 1
S - 72 - 355	347/0330 - 0355	EVA 1
S - 72 - 356	347/0354 - 0427	EVA 1
S - 72 - 357	347/0427 - 0554	EVA 1
S - 72 - 358	347/0554 - 0625	EVA 1
S - 72 - 359	347/0217 - 0247	EVA 1
S - 72 - 360	347/2339 - 2357	EVA 2
S - 72 - 361	347/2356 - 0151	EVA 2
S - 72 - 362	348/0150 - 0222	EVA 2
S - 72 - 363	348/0222 - 0336	EVA 2
S - 72 - 364	348/0335 - 0356	EVA 2
S - 72 - 365	348/0417 - 0520	EVA 2
S - 72 - 366	348/0520 - 0613	EVA 2
S - 72 - 367	348/0613 - 0636	EVA 2
S - 72 - 368	348/2239 - 2354	EVA 3
S - 72 - 369	348/2353 - 0025	EVA 3
S - 72 - 370	349/0024 - 0109	EVA 3
S - 72 - 371	349/0109 - 0201	EVA 3
S - 72 - 372	349/0201 - 0256	EVA 3
S - 72 - 373	349/0255 - 0327	EVA 3
S - 72 - 374	349/0327 - 0431	EVA 3
S - 72 - 375	349/0430 - 0511	EVA 3
S - 72 - 376	349/0501 - 0536	EVA 3
S - 72 - 377	349/2215 - 2248	EVA 4
S - 72 - 378	349/2246 - 0103	LEM LIFT-OFF AND DOCKING
S - 72 - 379	350/0102 - 0644	DOCKING AND IMPACT
S - 72 - 380	350/0644 - 0747	UNSCHEDULED TV IMPACT
S - 72 - 381	351/2350 - 0021	VIEW OF MOON AFTER TEI
S - 72 - 382	352/0021 - 0037	VIEW OF MOON AFTER TEI
S - 72 - 383	351/0149 - 0219	LUNAR SURFACE
S - 72 - 384	352/2032 - 2051	TRANS-EARTH EVA
S - 72 - 385	352/2051 - 2119	TRANS-EARTH EVA
S - 72 - 386	350/2300 - 2325	LUNAR SURFACE
S - 72 - 387	350/2325 - 2354	LUNAR SURFACE
S - 72 - 388	353/2300 - 2326	PRESS CONFERENCE

ORDERING PROCEDURES

Investigators engaged in specific lunar studies will find the photographic indexes and catalogs very important for selecting photographs appropriate to their studies. As stated earlier, a catalog of all panoramic camera frames can be obtained on one reel of 35-mm microfilm, whereas all usable mapping camera and Hasselblad camera photos can be obtained on microfiche or on reels of 16-mm microfilm. Corresponding indexes for these types of photos can be obtained on one reel of 16-mm microfilm or as microfiche. Microfiche cards include mapping and panoramic camera indexes as a set and Hasselblad and Maurer camera indexes as a set; one microfiche card contains the Nikon photography index, and one card contains the RCA and Westinghouse TV photography index.

When ordering Apollo 17 data, please refer to the index maps that are included with the data users note for the desired coverage and to the catalogs and indexes for the specific frame numbers of the desired photographs. Indicate the following in the request order:

- . Complete frame or reel number(s); e.g., AS17-116-18569 for Hasselblad and Nikon photographs, AS17-2676 for the panoramic, AS17-1614 for the mapping, AS17 - reel #83 for the RCA TV kinescope footage, and Maurer reel for the 16-mm Maurer photography
(AS = Apollo Spacecraft; 17 = mission number; 116 = magazine number; 18569 = frame number)
- . Form and size of reproduction; e.g., 8- x 10-in. B/W prints or 4- x 5-in. color positive transparency
- . Other identifying information; e.g., crater or feature name or location of desired portion within a frame of the panoramic camera coverage

The Apollo 17 Lunar Photography Order Form enclosed with this note is provided for the requester's convenience. The requester must complete all parts of the form to ensure satisfactory request fulfillment. All required photography should be identified in a single order to expedite the processing of the request.

Requesters should be aware of NSSDC policies concerning the dissemination of data. The purpose of the National Space Science Data Center is to provide data and information from space science experiments in support of additional studies beyond those performed by the principal investigators. Therefore, NSSDC will provide data and information upon request to any individual or organization resident in the United States. In addition, the same services are available to scientists outside the United States through the World Data Center A for Rockets and Satellites.

Normally, a charge is made for the requested data to cover the cost of reproduction and the processing of the request. The requester will be notified of the cost, and payment must be received prior to processing the request. The Director of NSSDC may waive, as resources permit, the charge for modest amounts of data when they are to be used for scientific studies or for specific educational purposes and when they are requested by an individual affiliated with: (1) NASA installations, NASA contractors, or NASA grantees; (2) other U.S. Government agencies, their contractors, or their grantees; (3) universities and colleges; (4) state and local governments; or (5) nonprofit organizations.

When a user submits a request, he should indicate the intended use of the ordered data. NSSDC would also appreciate receiving copies of all publications resulting from studies in which data supplied by NSSDC have been used. It is further requested that NSSDC be acknowledged as the source of the data in all publications resulting from use of the data provided.

Requesters may view the Apollo 17 photographs at NSSDC. Inquiries about or requests for photographs from U.S. scientists should be addressed to:

National Space Science Data Center
Code 601.4
Goddard Space Flight Center
Greenbelt, Maryland 20771
Telephone: (301) 982-6695
Telex No.: 89675 or 89676

Requests from researchers outside the U.S.A. should be directed to:

World Data Center A for Rockets and Satellites
Code 601
Goddard Space Flight Center
Greenbelt, Maryland 20771
U.S.A.
Telephone: (301) 982-6695
Telex No.: 89675 or 89676

Individuals or organizations that wish to obtain Apollo 17 photographic reproductions for purposes other than use in specific scientific research projects or college level space science courses should address their requests to:

Public Information Division
Audio-Visual Branch
Code FP
National Aeronautics and Space Administration
Washington, D.C. 20546
U.S.A.

The Public Information Division also has printed materials available to satisfy general information requests.

Representative sets of Apollo photographs suitable for framing can be obtained (at cost) as full-color lithographs from:

Superintendent of Documents
U.S. Government Printing Office
Washington, D.C. 20402
U.S.A.

Requests should specify NASA picture sets as follows:

- . NASA Picture Set 1, "Apollo - In the Beginning" (\$1.25)
- . NASA Picture Set 2, "Men of Apollo" (\$1.00)
- . NASA Picture Set 3, "Eyewitness to Space" (\$2.75)
- . NASA Picture Set 4, "First Manned Lunar Landing" (\$1.75)
- . NASA Picture Set 5, "Man on the Moon" (\$1.00)
- . NASA Picture Set 6, "Pinpoint for Science" (\$1.50)
- . NASA Picture Set 7, "Apollo 15" (\$1.50)

Inquiries or requests regarding pictures of the Earth taken during the Apollo missions should be directed to one of the following:

Technology Application Center
University of New Mexico
Albuquerque, New Mexico 87106
U.S.A.

or

U.S. Department of the Interior
Geological Survey
Earth Resources Observation Systems
Data Center
Sioux Falls, South Dakota 57198
U.S.A.

ACKNOWLEDGMENTS

NSSDC personnel wish to thank the individuals and organizations responsible for the photographs and supporting data obtained during the Apollo 17 mission. This mission photography was accomplished by the Apollo 17 crew: Astronauts Eugene A. Cernan, Harrison H. Schmitt, and Ronald E. Evans.

Arrangements to have the photographs and data available through NSSDC were made with the assistance of Dr. Richard Allenby, Mr. Leon Kosofsky, and Mr. George Eesenwein, NASA Headquarters; Mr. Andrew Patteson (Chief), Dr. Michael McEwen, Mr. Kenneth Hancock, and Mr. Robert Musgrove, Mapping Sciences Branch, NASA/Johnson Space Center; and Mr. John Williams of the Photographic Technology Division, NASA/Johnson Space Center. Special thanks are given to Nick Karlow of NSSDC for a critical reading of the DUN manuscript and to David Chiddix and Sarah Hickenbottom of PMI Facilities Management Corporation for the preparation of figures and photographs.

PRECEDING PAGE BLANK NOT FILMED

LIST OF ACRONYMS AND ABBREVIATIONS

AEI	Aerial Exposure Index
ALSEP	Apollo lunar surface experiments package
AOSPT	Apollo Orbital Sciences Photographic Team
AS	Apollo spacecraft
AU	Astronomical unit
AZ	azimuth
B	bulb
B/W	black and white (film)
CDR	commander
CEX	color exterior (film)
CIN	color interior (film)
circ	circular
CM	Command Module
CMP	Command Module pilot
CSM	Command and Service Modules
DAC	data acquisition camera
Def	Definition
deg	degree
diag	diagonal
DOI	descent orbit insertion
EDT	Eastern Daylight Time
EF	extra fast
Ekt	Ektachrome
E-M	electromagnetic
EO	Earth oriented
EROS	Earth Resources Observation Systems
EST	Eastern Standard Time
EVA	extravehicular activity
f	relative aperture (ratio of focal length to entrance pupil diameter)
f-c	foot candle
FMC	forward motion compensation
FOV	field of view
fps	frames per second
FWD	forward
GCTA	ground controlled television assembly
GET	ground elapsed time
GMT	Greenwich mean time
HBW	high-speed black and white (film)
HCEX	high-speed color exterior (film)
HEC	Hasselblad electric camera
HEDC	Hasselblad electric data camera
hor	horizontal
hr	hour
JSC	Johnson Space Center (formerly MSC)
LBW	low-speed black and white (film)

LM	Lunar Module
LMP	Lunar Module pilot
LOI	lunar orbit insertion
LRV	Lunar Roving Vehicle
mag	magazine
MASCON	mass concentration
MCS	mapping camera system
MESA	modularized equipment storage assembly
MeV	million electron volts
MNVR	maneuver
mrad	milliradian
MS	medium speed
MSC	Manned Spacecraft Center (now JSC)
msec	millisecond
n.m.	nautical mile
nsec	nanosecond
NSSDC	National Space Science Data Center
NTB	Nuclear Track (Series) B (film)
NTSC	National Television Systems Committee (color trademark for TV)
pic	picture
PMT	photomultiplier tube
REV	orbital revolution number
rpm	revolutions per minute
Rx	receiving
S/C	spacecraft
sec	second
SIM	Scientific Instrument Module
SIV-B	Saturn IV booster rocket
SM	Service Module
SO	special order
STA	station
T	time
TAC	Technology Application Center
TEC	transearth coast
TEI	transearth injection
TLC	translunar coast
TLI	translunar insertion
Tx	transmission
TYP	typical
USGS	United States Geological Survey
UT	universal time
UV	ultraviolet
vert	vertical
V/H	velocity-to-height ratio
VHBW	very high-speed black and white (film)

REFERENCES

1. "Apollo 17 Preliminary Science Report," NASA-SP-330, 1974.
2. "Apollo Data Users Handbook" (in preparation at NASA-JSC, Houston, Texas).
3. "SIM Bay Photographic Equipment and Mission Summary, Apollo 17 Supplement," NASA-JSC, Houston, Texas, June 1973.

SOURCE LIST

"Apollo Mission J-3 (Apollo 17) Mission Science Planning Document Revision," MSC-05871, October 11, 1972.

Aviation Week, 97, 25, 12-19, December 18, 1972.

Aviation Week, 98, 1, 30-46, January 1, 1973.

Aviation Week, 98, 6, 42-45, February 5, 1973.

Aviation Week, 98, 11, 14-15, March 12, 1973.

Aviation Week, 98, 14, 46-48, March 12, 1973.

Aviation Week, 98, 16, 38-43, April 16, 1973.

Aviation Week, 98, 19, 52-57, May 7, 1973.

"CSM/LM Spacecraft Operational Data Book for J-Missions," North American Rockwell Corp., SNA-8-D-027, NASA-JSC, Houston, Texas, September 22, 1970.

Doyle, F. J., "Photographic Systems for Apollo," Photogrammetric Engineering, 25, October 1970.

El-Baz, F., "Preliminary Evaluation of Apollo 17 Orbital Photography," National Air and Space Museum, Smithsonian Inst., February 7, 1973 (Contract NGR 09-015-206).

Spaceflight, 15, 2, 42-47, February 1973.

Spaceflight, 3, 2, 87-91, March 1973.

PRECEDING PAGE BLANK NOT FILMED

APPENDIX A
EXPERIMENTS PACKAGE

APPENDIX A
EXPERIMENTS PACKAGE

EXPERIMENT	NO.	PRINCIPAL INVESTIGATOR	ADDRESS	OBJECTIVE
COMMAND MODULE				
Hasselblad Electric Camera (HEC) Photography	--	Mr. Frederick J. Doyle Chairman, Apollo Orbital Science Photographic Team (AOSPT)	USGS National Center, 516 12201 Sunrise Valley Drive Reston, Virginia 22092 (703) 860-6235	To obtain photos of lunar surface features of scientific interest from orbit and to photograph low brightness astronomical and terrestrial sources.
Nikon Camera Photography	--	Mr. Frederick J. Doyle Chairman, AOSPT	USGS National Center, 516 12201 Sunrise Valley Drive Reston, Virginia 22092 (703) 860-6235	To obtain photos of lunar surface features of scientific interest from orbit and to photograph low brightness astronomical and terrestrial sources.
Apollo Window Meteoroid	S-176	Mr. B. G. Cour-Palais	Geology Branch, Planetary and Earth Sciences Division, Code TM61 NASA-JSC Houston, Texas 77058 (713) 483-4757	To obtain data on meteoroid cratering flux of masses 10^{-12} to 10^{-7} grams.
Visual Observations	--	Dr. Farouk El-Baz	National Air and Space Museum Smithsonian Institution Washington, D.C. 20560 (202) 484-7636	To make and record observations of particular surface features and processes.
Gamma-Ray Spectrometer	S-160	Dr. James R. Arnold	Chemistry Department University of California at San Diego La Jolla, California 92037 (714) 454-2000 Ext. 1453	To obtain data to remove background noise from galactic observations obtained on Apollo 16.
SERVICE MODULE				
Panoramic Camera Photography	--	Mr. Frederick J. Doyle Chairman, AOSPT	USGS National Center, 516 12201 Sunrise Valley Drive Reston, Virginia 22092 (703) 860-6235	To obtain high-resolution panoramic photos with stereoscopic coverage of the lunar surface.
Mapping Camera Photography	--	Mr. Frederick J. Doyle Chairman, AOSPT	USGS National Center, 516 12201 Sunrise Valley Drive Reston, Virginia 22092 (703) 860-6235	To obtain high quality metric photos of surface together with simultaneous stellar photos for attitude.
Stellar Camera Photography	--	Mr. Frederick J. Doyle Chairman, AOSPT	USGS National Center, 516 12201 Sunrise Valley Drive Reston, Virginia 22092 (703) 860-6235	To obtain simultaneously stellar photos for spacecraft attitudes together with lunar surface metric photos.
Laser Altimeter	--	Mr. Frederick J. Doyle Chairman, AOSPT	USGS National Center, 516 12201 Sunrise Valley Drive Reston, Virginia 22092 (703) 860-6235	To obtain ranging data for determination of altitude of CSM simultaneously with metric and stellar photos.

APPENDIX A (continued).

EXPERIMENT	NO.	PRINCIPAL INVESTIGATOR	ADDRESS	OBJECTIVE
S-Band Transponder	S-164	Mr. William L. Sjogren	Jet Propulsion Laboratory Mail Code 156-231 4800 Oak Grove Drive Pasadena, California 91103 (213) 354-4868	To obtain S-band doppler resolver tracking data for mass distribution along ground track.
Far UV Spectrometer*	S-169	Dr. William Fastie	Physics Department Johns Hopkins University Salisbury, Maryland 21218 (301) 336-3300 Ext. 371	To determine atomic composition, density, and scale height of lunar atmosphere and to investigate far UV radiation from lunar surface and galactic sources.
IR Scanning Radiometer	S-171	Dr. Frank J. Low	Lunar and Planetary Laboratory University of Arizona Tucson, Arizona 85721 (601) 884-2727	To measure from orbit the lunar surface for a high-resolution surface temperature map.
Lunar Sounder	S-209	Dr. Roger Phillips Team Chairman	Jet Propulsion Laboratory Mail Code 185-501 4800 Oak Grove Drive Pasadena, California 91103 (213) 354-4973	To obtain stratigraphic, structural, tectonic, and topographic data by electromagnetic sounding, to get ambient E-M noise levels, and to measure lunar occultation of E-M waves.
LUNAR MODULE AND LUNAR SURFACE				
Heat Flow	S-037	Dr. Marcus E. Langseth	Lamont-Doherty Geological Observatory Columbia University Palisades, New York 10964 (914) 359-2900 Ext. 335	To determine rate of heat loss from lunar interior.
Lunar Geology Inves- tigation	S-059	Dr. William R. Muehlberger	Center of Astrogeology U.S. Geological Survey Flagstaff, Arizona 86001 (602) 774-1483	To obtain better under- standing of the Taurus-Littrow area and the processes which have modified it.
Cosmic-Ray Detector	S-152	Dr. Robert M. Walker	Division of Geology and Planetary Science California Institute of Technology Pasadena, California 91109 (213) 795-6841 Ext. 2117	To measure mass and energy distribution of solar wind and cosmic-ray particles in energy range 1 keV to 25 MeV/AMU, to determine quiescent energy spectrum of composition of particles with Z \geq 6 in interplanetary space, and to determine the Rn^{222} flux at the surface.
Traverse Gravimeter	S-199	Dr. Manik Talwani	Lamont-Doherty Geological Observatory Columbia University Palisades, New York 10964 (914) 359-2900 Ext. 224	To make a high-accuracy survey of relative gravitational field in landing area and to make an Earth-Moon gravity tie.

*Photography still proprietary and will be announced when available.

APPENDIX A (continued)

EXPERIMENT	NO.	PRINCIPAL INVESTIGATOR	ADDRESS	OBJECTIVE
Soil Mechanics (Passive Experiment)	S-200	Dr. James K. Mitchell	University of California at Berkeley 440 Davis Hall Berkeley, California 94726 (415) 642-1262	To obtain data on the physical characteristics and mechanical properties of the soil at the surface and subsurface and their lateral variations.
Lunar Ejecta and Meteorites	S-202	Dr. Otto E. Berg	Goddard Space Flight Center Code 641 Greenbelt, Maryland 20771 (301) 982-5920	To measure physical parameters of primary cosmic dust impacts on sensors in cislunar space and of lunar ejecta emanating from meteorite impact sites on the Moon.
Lunar Seismic Profiling	S-203	Dr. Robert L. Kovach	Department of Physics Stanford University Stanford, California 94305 (415) 321-2300 Ext. 4827	To acquire data on physical properties of lunar near- surface materials and to mon- itor moonquakes and impacts.
Surface Electrical	S-204	Dr. E. M. Simmons	Massachusetts Institute of Technology MIT 54-314 Cambridge, Massachusetts 02137 (617) 864-6900 Ext. 6393	To get data on electromagnetic energy transmission absorption and reflection characteristics of surface and subsurface for a geologic model of upper layers of the Moon; to detect layering and water below surface and electrical properties in situ.
Lunar Atmospheric Composition	S-205	Dr. John H. Hoffman	Atmospheric and Space Science University of Texas at Dallas Dallas, Texas 75230 (214) 231-1471 Ext. 322	To obtain data on composition of ambient lunar atmosphere in mass range 1-110 AMU at surface and to detect transient changes from gas venting of lunar surface.
Lunar Surface Gravimeter	S-207	Dr. Joseph Weber	Department of Physics and Astronomy University of Maryland College Park, Maryland 20742 (301) 454-3526	To obtain highly accurate measures of gravitational acceleration and its temporal variations at a selected point on the surface.
Lunar Neutron Probe	S-229	Dr. Don S. Burnett	Division of Geology and Planetary Science California Institute of Technology Pasadena, California 91109 (213) 795-6841 Ext. 2117	To measure neutron capture rates in lunar regolith and variations as a function of depth and to gain information on lunar neutron energy spectrum.

APPENDIX B

SAMPLES OF APOLLO 17 PHOTOGRAPHY

Samples of Apollo 17 Photography

The following pages contain sample photographs, as identified below, taken during the Apollo 17 mission.

- B-1. Nikon camera enlargement (Frame AS17-162-24105, Magazine SS) containing a view of the far side of the Moon with the crater Orlov below center.
- B-2. Metric camera photograph (Frame AS17-0595) showing the Apollo 17 landing site (arrow).
- B-3. Panoramic camera reduced photograph (Frame AS17-2309) showing the vicinity of the Apollo 17 landing site (arrow). North is at the top of the photograph.
- B-4. Hasselblad camera contact print (Frame AS17-143-21856, Magazine N) showing Commander Cernan and the Lunar Roving Vehicle at Station 9, with North Massif in the background.
- B-5. Hasselblad camera contact print (Frame AS17-150-23004, Magazine LL) showing the landing site (arrow) in the Taurus-Littrow valley. The landslide area at center bottom is from South Massif.
- B-6. Hasselblad camera contact print (Frame AS17-144-21991, Magazine R) showing a boulder and its track on North Massif.
- B-7. Hasselblad camera contact print (Frame AS17-150-23038, Magazine LL) showing the crater Picard in the Mare Crisium.



Figure B-1. Nikon Camera

B-4

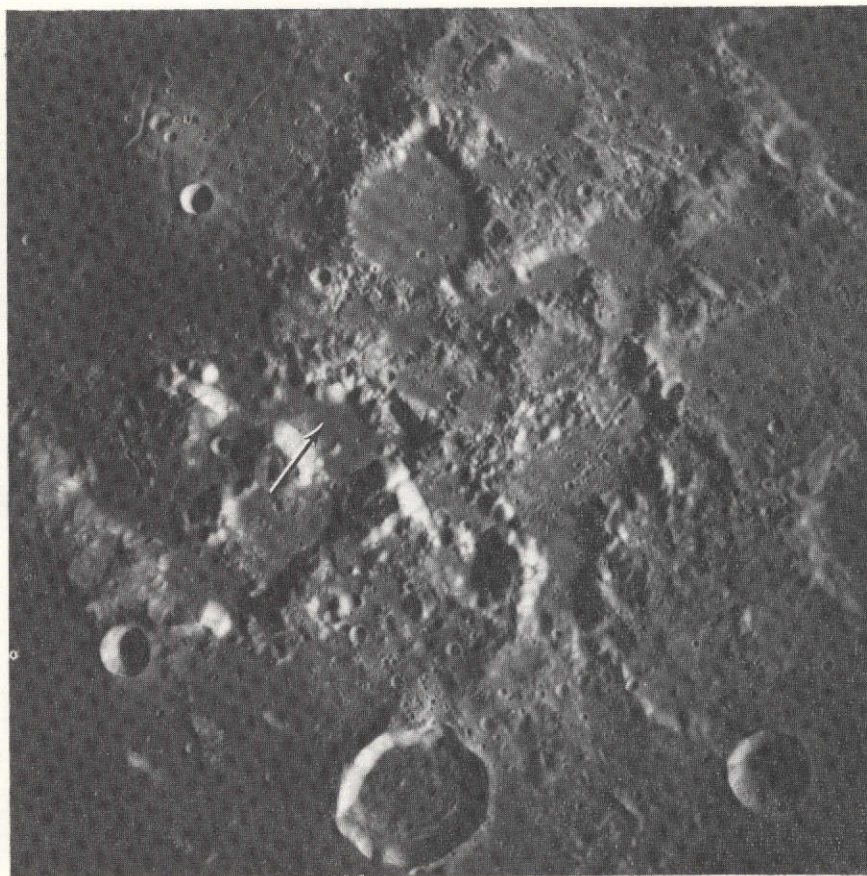

Figure B-2. Metric Camera

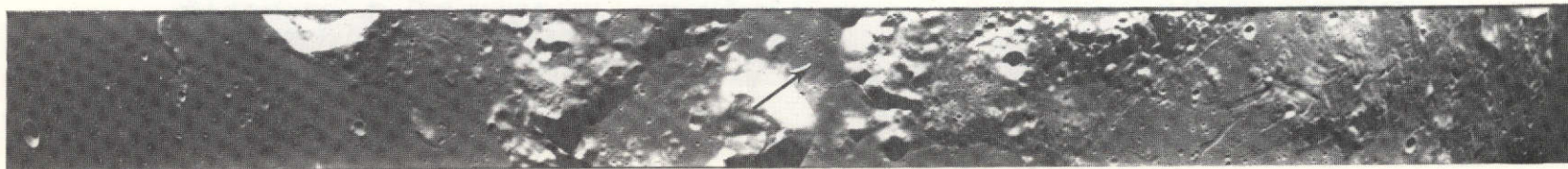

Figure B-3. Panoramic Camera (reduced from 5 x 48 in.)

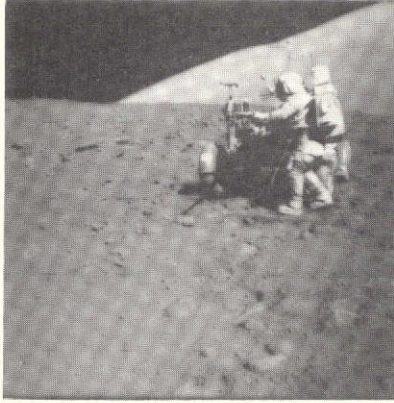

Figure B-4. 60-mm Hasselblad
(Surface)



Figure B-5. 250-mm Hasselblad
(Orbit)

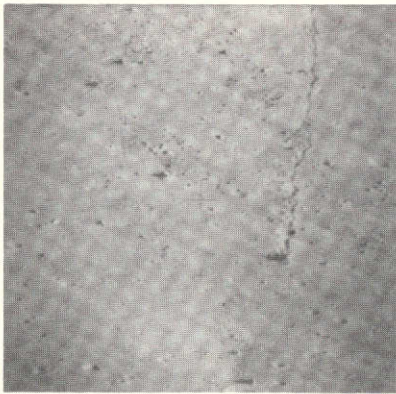

Figure B-6. 500-mm Hasselblad
(Surface)



Figure B-7. 80-mm Hasselblad
(Orbit)



NATIONAL AERONAUTICS AND SPACE ADMINISTRATION
GODDARD SPACE FLIGHT CENTER
GREENBELT, MARYLAND 20771

NATIONAL SPACE SCIENCE DATA CENTER
CODE 601

December 1974

TELEPHONE
301-982-6695

Dear Colleague:

The Apollo 17 Lunar Photography Data Users Note has been prepared by the National Space Science Data Center (NSSDC) with important contributions being provided by Mr. George Esenwein and Mr. Leon Kosofsky, Lunar Programs Office, NASA Headquarters. The purpose of this document is to provide you with substantial information on the photography taken during the Apollo 17 mission and to aid you in the selection of Apollo 17 photographs for study. Eight index maps indicating the areas covered by the photographs are being sent with this note.

It should be noted that this information package is quite different from those for the Apollo 11 through Apollo 14 missions. NSSDC, with the aid of the Mapping Sciences Laboratory, Johnson Space Center, prepared photographic proof print catalogs and frame index data in the form of printed documents for these earlier flights. The volume of photography and data increased so greatly with Apollo 15, however, that, starting with that mission, they have been prepared in microform. They are therefore not included with this package. A complete description of the microform photographic catalogs and supporting data available from NSSDC can be found in this note under the discussions of each of the camera types in the section "Description of Photographic Objectives, Equipment, and Available Data." The rectified panoramic camera photography for Apollos 15, 16, and 17 is now available and described in this document. An order form is provided at the end of the data users note for your use in ordering all forms of Apollo 17 data available from NSSDC.

Your comments on the contents of the Apollo 17 documentation and on the services offered by NSSDC are invited.

Very truly yours,

A handwritten signature in cursive script that reads "James I. Vette".

James I. Vette
Director, NSSDC

APOLLO 17 PRICE LIST

PHOTOGRAPHIC INDEXES

One reel of 16-mm microfilm containing the Hasselblad, mapping (metric), panoramic, Nikon, and Maurer camera indexes.....	\$4.15
Hasselblad and Maurer indexes on microfiche.....	1.25
Panoramic and mapping (metric) camera indexes on microfiche.....	.75
Nikon indexes on microfiche.....	.25

PHOTOGRAPHIC CATALOGS

<u>CAMERA TYPE</u>	<u>MICROFICHE</u>		<u>16-mm ROLL FILM</u>	<u>35-mm ROLL FILM</u>
	<u>NSSDC</u>	<u>CAL TECH</u>		
Hasselblad	\$29.60	\$17.20	\$9.60	—
Mapping (metric)	24.00	23.60	4.80	—
Panoramic	—	—	—	\$6.20

COMPLETE SETS OF PHOTOGRAPHS (on continuous rolls)

<u>SIZE AND CAMERA TYPE</u>	<u>CONTACT PRINTS</u>	<u>FILM TRANSPARENCIES</u>
70-mm Hasselblad	\$ 78.65	\$ 179.15
35-mm Nikon	—	6.20
5-in. mapping (metric)	285.53	526.57
5-in. panoramic	877.45	1625.85
9.5-in. rectified panoramic	3300.70	4730.70
16-mm Maurer color films	—	207.00
16-mm kinescope B/W roll film	—	2150.00

TYPICAL PER ITEM COSTS (black and white reproductions only) *

FORM	SIZE	COST	FORM	SIZE	COST
PRINTS	4 x 5 in.	\$0.50	FILM DUPLICATES	4 x 5 in.	\$0.70
	5 x 5 in.	0.65		5 x 5 in.	0.90
	8 x 10 in.	0.70		5 x 48 in.	3.95
	11 x 14 in.	0.75		9.5 x 80 in.	8.00
	16 x 20 in.	2.00	SLIDES	2 x 2 in.	0.90
	20 x 24 in.	3.00		2.25 x 2.25 in.	0.95
	5 x 48 in.	2.50		3.25 x 4 in.	1.75
9.5 x 80 in.	3.50				

* Prices for color reproduction services will be quoted upon request.

Hasselblad 70-mm magazines are available individually at the prices listed below. Please note that color prices are given for individual 4- x 5-in. negatives. Color 70-mm contact paper prints and 70-mm roll film transparencies (positive or negative) are not available.

<u>MAGAZINE</u>	<u>B/W PAPER PRINTS</u>	<u>B/W FILM TRANSPARENCIES</u>	<u>COLOR FILM TRANSPARENCIES</u>
Mag A	\$ 5.84	\$ 9.26	\$ 234.00
Mag B	5.84	9.26	235.50
Mag C	5.93	9.47	243.00
Mag D	5.84	9.26	234.00
Mag E	5.93	9.47	238.50
Mag F	5.93	9.47	243.00
Mag KK	6.02	9.68	250.50
Mag LL	6.02	9.68	246.00
Mag MM	6.20	10.10	259.50
Mag NN	6.11	9.89	253.50
Mag OO	6.02	9.68	246.00
Mag PP	6.65	13.25	376.50
Mag H	6.38	10.52	—
Mag I	5.84	9.26	—
Mag J	6.29	10.31	—
Mag K	6.02	9.68	—
Mag L	5.93	9.47	—
Mag M	6.02	9.68	—
Mag N	5.75	9.05	—
Mag R	5.75	9.05	—
Mag G	5.67	8.84	—