

First Year Technical Report  
Theoretical Acoustics Division  
National Aeronautics and Space Administration  
Langley Research Center  
Grant NGR 23-004-091

(NASA-CR-142069) DEVELOPMENTS IN THE LARGE ANGLE OBLIQUE JET IMPINGEMENT FLOW INVESTIGATION (Michigan State Univ.) 19 p  
HC \$3.25 CSCL 20D Unclas  
G3/34 Q9008

## DEVELOPMENTS IN THE LARGE ANGLE OBLIQUE JET IMPINGEMENT FLOW INVESTIGATION

prepared by  
John F. Foss



Division of Engineering Research  
MICHIGAN STATE UNIVERSITY  
East Lansing, Michigan 48824  
February 12, 1975

First Year Technical Report  
Theoretical Acoustics Division  
National Aeronautics and Space Administration  
Langley Research Center  
Grant NGR 23-004-091

DEVELOPMENTS IN THE LARGE ANGLE OBLIQUE  
JET IMPINGEMENT FLOW INVESTIGATION

prepared by  
John F. Foss

Division of Engineering Research  
MICHIGAN STATE UNIVERSITY  
East Lansing, Michigan 48824  
February 12, 1975

## 1. INTRODUCTION

This report describes the first year activities of an investigation, "The Structure of a Large Angle Oblique Jet Impingement Flow," which has been conducted at Michigan State University for the Theoretical Acoustics Branch of the NASA Langley Research Center. Its purpose is to communicate the results which have been achieved in fulfilling the objectives identified in the original proposal and to identify the modification of these objectives as suggested by the initial results of this study and as evolved in consultation with the cognizant personnel of the Langley Research Center, primarily Dr. J. C. Hardin, grant monitor.

The objectives for the first year were (1) to document the mean flow field for the large angle oblique jet impingement flow and (2) to execute vorticity measurements in the region of the flow primarily responsible for the production of acoustic noise. The mean flow documentation was completed rather early (January 1974) in this grant year and was submitted as a third year technical report to the NASA Lewis Research Center in recognition of their earlier support of the jet impingement studies at MSU and to complete our association with them. This report includes extensive, single-wire (hot-wire) measurements of the mean velocity and turbulence quantities near the plate for a 45-degree impingement flow. The next section summarizes these results and presents the conclusions which shaped the subsequent direction of the present study. The third and fourth sections of this report describe these subsequent activities: (1) the construction of a new experimental facility and (2) the development of a unique signal processing circuit to infer the instantaneous transverse vorticity\* from an array of four hot-wires.

The continuing efforts within the scope of this research project have been adequately summarized in the renewal proposal submitted on September 20, 1974. It is pertinent to note that the present report updates some aspects of the current work identified in this proposal.

---

\* "Instantaneous"--up to 100,000 samples/sec.; "transverse"--parallel to the plate and perpendicular to the mean flow direction; "vorticity"--the quantity  $\Delta u/\Delta z - \Delta w/\Delta x$  is measured within the spatial resolution of the four-probe array.

## 2. MEAN FLOW FIELD DOCUMENTATION/ALTERATION OF THE RESEARCH OBJECTIVES OF THE PRESENT STUDY

The intensity of the turbulence fluctuations in the neighborhood of the impact plate is not significantly greater than the intensity in the free jet which would exist in the absence of the plate (see Foss [1974 a, b]). Consequently, unless the increased acoustic energy can be related to an increased volume of turbulence kinetic energy--a possibility which cannot be assessed on the basis of the extant data--the observed acoustic emission is apparently the result of an enhanced "organization" of the flow associated with the impingement process. The vorticity field surrounding the stagnation point and the vorticity effects associated with the deformation and reorganization of the vorticity of the approaching jet are the two significant aspects of the organized motions within the flow field. These qualitative considerations are given a structure in the multipole expansion by Hardin [1973]. He identified the volume integral of the vorticity-velocity product as the flow field characteristic responsible for the far field density (hence pressure and velocity) variation. The cross-correlation of such products in space and time is therefore responsible for the average sound power emitted by the impinging jet. These considerations suggest that a suitable neighborhood of the stagnation point be selected for extensive investigation of the vorticity-velocity field.

The mean velocity field near the plate ( $z/d \cong 0.05$ ) is observed to be symmetric about the stagnation point ( $x/d \cong -0.9$ ) within the approximate region  $r/d < 3$ . This  $z$  location is also the plane for which  $\partial u_r / \partial z \cong 0$ ; i. e., the vertical location where the transverse vorticity changes sign.\* It was decided to focus attention on this region for future studies since it appeared to form a natural subregion of the total impingement flow, one which is responsible for a substantial portion of the acoustic emission.

Since the 0.75-inch nozzle used by Foss [1974 a] resulted in a concentration of the transverse vorticity in a region of height  $\leq 0.04$  inch from the plate--that is, within the nominal span of the parallel wires of the vorticity array (!)--a larger nozzle was required. Also, it was experienced with the rotating nozzle configuration that the lack of "perfect" rigidity of the structure caused a slight movement of the impinging jet flow as the

---

\*  $\bar{w}_t = \partial \bar{u} / \partial z - \partial \bar{w} / \partial s \cong \partial \bar{u} / \partial z$ .

angle ( $\theta$ ) was varied. Consequently, the development of a new flow facility with a rigid jet and a corresponding four-position ( $x, y, z, \theta$ ) traverse system (which would allow traverses about the stagnation point and not just along radial lines through the geometric intersection point of the nozzle) was undertaken. The new facility includes a (nominal) 3-inch diameter jet (7.72 cm) in order to enlarge the vortical motion region near the plate surface while maintaining feasible values of the impact plate size and the volume-flow-rate/velocity requirements of the flow system. Details of the flow system and the vorticity probe are provided in section 3 of this report.

The identification of the concentrated vorticity region,  $0 \leq z/d \leq 0.05$ , and the recognition that the streamwise velocity can be a significant fraction of the jet exit velocity at this elevation suggests that the characteristic vorticity values can be quite large. A representative value for the experiments using the new facility is:

$$\omega \approx U_j / 0.05d \approx 7,000 \text{ sec}^{-1}.$$

Similarly, the relatively large velocity and small characteristic lengths suggest that rather high frequency components may be expected for the vorticity fluctuations. The data processing scheme advanced in the original proposal involved the use of the available A/D converter and software computations of the derivatives to construct the transverse vorticity. Using this procedure, a time lag of  $65 \mu\text{sec}$  between individual readings would occur; hence the time required for the construction of the vorticity signal would be  $260 \mu\text{sec}$  or an equivalent rate of 3840 hz. This rate is insufficient to guarantee an adequate resolution of  $\omega_t$ . A faster A/D converter with input to the T.I. memory (direct memory access) at 50 KHz (or a four-channel rate of 12.5 KHz) was considered; this would have possibly offered a satisfactory procedure. With this operating strategy, the computer would read a set of values and either store them or compute  $u$ ,  $w$ , and  $\omega_t$  from these values and then store them. The monitor and operating routines would require some fraction of the 20 K memory locations; hence the sample size would be limited by this consideration to  $\approx 10\text{-}14\text{K}$  words or  $\approx 3,000$  sets of data from which to compute  $u$ ,  $w$ , and  $\omega_t$ .

These considerations started the evolution of an alternative signal processing scheme; the development of a special digital electronic processor

that will be dedicated to the computation of the velocity component values  $u$ ,  $w$  and the transverse vorticity from the four hot-wire inputs is the end product of this evolution. A maximum through-put rate of 100 KHz will be possible with this unit, and its accuracy will be established by the use of tabulated calibration information (velocity/voltage) from the four wires and the pitch angle response of the x-wires. The digital unit is described in section 4 of this report and will be the subject of a special report detailing its operating principles and design, as well as the operating procedures and maintenance considerations.

Because the digital processor represents a new computing technique and because the measurement of  $\omega_t$  by the four-wire array is not a standard procedure, it was considered advisable to conduct a special set of experiments to evaluate the vorticity measuring capability. These experiments will be for the conditions  $\alpha = \pi/2$ ,  $h/d = 1$ , and they will be coordinated with surface pressure measurements to evaluate  $2\pi r \int_0^\delta \overline{u \omega_t} dz$  and with acoustic measurements to evaluate the sound producing/vorticity characteristics of such a flow. The details of this experimental program are presented in the renewal proposal submitted in September 1974.

### 3. EXPERIMENTAL FACILITY

The flow system described in the original proposal and used in the study which has established the mean flow results (Foss [1974a]) will be modified before the vorticity measurements are executed. The flow system modifications are shown in Figure 1. The new flow system incorporates a fixed, large-bore (3.04-inch) nozzle. The nozzle shape has been designed in accord with the criteria of Chmielewski [1974], which results in a minimum length nozzle for an unseparated flow within the contraction region.

The probe support unit and the z-drive will be mounted on the impact plate; these will be traversed by means of the computer-controlled stepping motors to survey the jet. Figure 2 shows a schematic representation of this facility. Note that the adjustment controls shown in Figures 2b and 2c will allow the measuring tip of the probe to be located precisely over the axis of rotation of the plate; consequently, the  $x$ ,  $y$ , and  $\theta$  positions may be independently established. A significant alteration in our position control techniques will be incorporated with this new design. Specifically,

the open loop system, in which the T.I. drove the probe into position by a certain number of impulses applied to the stepper motors, will be replaced by a closed loop system wherein the T.I. sets a digital value in an appropriate register and the stepper motor is activated until the position sensor unit indicates agreement between the preset condition and the position of the probe. A block diagram representation of this circuit is presented in Figure 3. The principles for this technique are, of course, well established; the implementation of a digital circuit to execute this control function will involve certain innovative electronic design features and will serve as the special project (EE 403) of Mr. D. Sigmon.

Figure 4 shows the vorticity probe to be used for this study. Two characteristics of the x-wire in this probe system will be determined, viz., the pitch angle response, which will be utilized in the u, w calculations as noted in the next section, and the yaw angle values required to degrade the response of the probe. That is, the value of the yaw angle ( $\Xi = \arctan v/u$ ) which will cause one of the x-wires to be influenced by the presence of the adjacent one will be determined. Based upon a similar evaluation for a Disa-type miniature x-probe, a yaw angle of 30 degrees is not sufficient to create such a degraded response. If a similar response for the TSI probe is observed, the probe will be quite satisfactory for the intended application since the expected yaw angles are not anticipated to exceed a value of 30 degrees. Yaw angle measurements in the impinging jet flow will be made (instantaneous u, v values will be recorded) to evaluate this assertion.

One additional modification as regards our earlier formulated plans should be noted; the bridge vs. the linearized signals from the four TSI hot-wire anemometers will be utilized for this study. The 12-bit A/D converters can be used to segment the nominal two-volt range provided by these units into 4096 parts; i. e., a resolution of 0.5 mv is available. This alteration is made possible by the resolution and by the use of a discrete element calibration table; it is motivated by the presence of high frequency noise from the linearizer electronics which would degrade the vorticity measurements.

#### 4. DATA PROCESSING

An early concept in our development of the data processing procedures was to employ sufficient equipment external to the T.I. minicomputer

to allow the voltage data to be input to memory at a faster rate than the 65  $\mu$ sec between individual voltage readings allowable with the T.I. system. The present concept is quite different from this, and because of its possible benefit to other researchers, the basic elements of the scheme will be described herein. A special report to document this device and the principles of its operation will be issued later.

The function of the device is to provide a real time evaluation of the streamwise and vertical velocities and the transverse vorticity component as deduced from four hot-wire voltage signals. For convenience, the device will hereafter be referred to as the Vorcom, an abbreviated designation of its function as a vorticity computer.

The Vorcom will operate in one of three mutually exclusive modes, these being (1) the programming mode, (2) the processing mode, and (3) the self-check mode. Modes 1 and 3 are somewhat self-explanatory and do not require extensive description; mode 1 is dealt with first. The processing mode is treated in detail.

The use of the Vorcom is initiated by the transfer of information from the T.I. minicomputer to the Vorcom. Specifically, the calibration tables\* of velocity vs. voltage will be stored for the four hot-wire channels. The desired reading rate will also be input in terms of the fraction of the 100 Khz maximum to be employed; in particular, reading rates of 100, 50, 33.3, 25, 20, . . . Khz will be available by recording each, every other, every third, etc., signals from the Vorcom. This flexibility is desired since the lowest possible reading rate to adequately recover the high frequency information from the flow will allow the longest possible data acquisition time.

The two sets of information described above will be particular to each data acquisition run. In addition, the information concerning the pitch angle response of the x-wire probes will be stored in a random access memory. This tabulation is a function of the probe geometry and will be reevaluated only if a probe repair must be executed.

The essential operating features of the Vorcom's processing mode

---

\*Increments of 0.5 fps will be used from the minimum flow speeds of interest ( $\approx$  10 fps) to 30 fps. From this value to the maximum speeds to be encountered in the flow ( $\approx$  120 fps), the velocity calibration will be stored in values of 0.5 percent of the local value.



are presented in the block diagram of Figure 5. The signal flow of the two parallel wires is quite straightforward; the calibration tables convert the voltages to velocities, the velocity difference provides the quantity  $\Delta u$  and equivalently  $\Delta u/\Delta z \approx \partial u/\partial z$ , and the delay steps are to synchronize the derivative with the quantity  $\partial w/\partial x$  under construction in the balance of the circuit.

Similarly, the x-wire voltages pass through their respective calibration tables in order to define the quantities  $V_{\text{eff}}^{(1,2)}$ . The effective cooling velocity is expressed by the relationship

$$V_{\text{eff}} = V f(\gamma, V)$$

where  $f$  is a function of the angle between the wire and the velocity vector ( $\gamma$ ) and the velocity magnitude. The latter dependence is rather weak. Numerous forms have been proposed for the function  $f$ ; the simplest of these is the cosine relationship. The others represent some modification thereof; example forms are:

$$f'(\gamma) = [\cos^2 \gamma + K^2 \sin^2 \gamma]^{1/2}, \text{ Hinze [1959]}$$

$$f'(\gamma) = \cos^m \gamma, \text{ Brunn and Davies [1971]}$$

$$f'(\gamma) = \cos \gamma + \epsilon(\cos \gamma - \cos^2 \gamma), \text{ Fujita and Kovasznay [1968].}$$

Since the two  $V_{\text{eff}}$  values are known and since the two  $\gamma$  values are related by a constant difference, it is possible to construct the following scheme to infer  $\gamma$ :

$$\text{V. R.} \equiv \frac{V_{\text{eff}}^{(1)}}{V_{\text{eff}}^{(2)}} = \frac{f(\gamma_1, V)}{f(\gamma_2, V)}$$

and

$$\gamma_1 = k\pi/2 - \gamma_2$$

where  $k = 1$  if the wire axes are perpendicular. Consequently, the  $V_{\text{eff}}$  ratio forms one equation for two unknowns,  $\gamma_2$  and  $u$ . The weak dependence of this ratio on  $V$  allows a computing strategy (1) to infer  $\gamma$  by using  $V$  from the previous time step\* and (2) to calibrate the pitch response of

---

\* Logically, this requires an a priori knowledge of  $V$  to initiate the first step of the computing process. This requirement will be met by initiating the data acquisition when the velocity vector is parallel with the probe shaft ( $\gamma = 0$ ), as revealed by a predetermined V. R. value.

the x-wire and develop tabulated values of  $V. R. = G_V(\gamma)$ , where  $G_V$  indicates that a given value of  $V$  was used in the development of the function  $G$ .

The tables representing the  $\gamma = G_V^{-1}(V. R.)$  functions will be stored at velocity intervals suggested by the strength of the observed velocity dependence. The results of Webster [1962] and Brunn and Davies [1971] suggest that perhaps eight tables covering the range  $10 \text{ fps} \leq u \leq 120 \text{ fps}$  may be satisfactory. The required span of the tables can be inferred from the r.m.s. data of Foss [1974a]. From these data, it is inferred that a pitch angle calibration covering  $\pm 30$  degrees will be quite adequate. If 0.5-degree increments are used, then 120 values per velocity level are required. One table can hold 1,024 entries; consequently, if eight velocity levels are satisfactory, the  $G_V^{-1}(V. R.)$  table will be fit into one of the three available tables.

The design of the Vorcom is based upon several key considerations. First, the entire unit is controlled by a master, 20 mhz, clock. There are 200 time steps from the four A/D conversions which start the calculation to the appearance of the three 8-bit numbers which specify the velocity components ( $u, w$ ) and the transverse vorticity ( $\omega_t$ ). Each operation within the processor is specified in terms of its initial and final "location" within the 200 time-step interval.

A fast (200 ns) 12 x 12-bit, 2's complement, multiplier is shared by the different parts of the circuit at the appropriate times within the  $10 \mu\text{sec}$  interval. Read-only-memory (ROM) units allow the rapid retrieval of the fixed functions, sine and cosine. These ROM units are fast (two time steps) and their contents are protected since there are no input ports; a special ROM programmer has been developed for their programming.

Following the programming mode and the state of readiness of the experiment, the processing mode will be initiated and maintained until the data storage buffer is filled. The output from the Vorcom will be two 8-bit numbers packed in a 16-bit word. The words will represent 8 bits for  $u$ , 7 bits + sign for  $\omega_t$  or 7 bits + sign for  $w$ , and 7 bits + sign for  $\omega_t$ . These alternating words will be stored in the T. I. minicomputer at the rate of 50 Khz (DMAC input) or less. If the 100 Khz rate is required, then a separate memory buffer will be required. Considering the core memory requirements for the monitor and worker routines, approximately 12 K memory locations will be available for data storage. At 50 Khz, this represents

0.24 sec for continuous data acquisition. Repeated samples would then be required to construct the low frequency statistics. These considerations suggest an optimal data sampling scheme in which a short sample may be sufficient to obtain the stationary characteristics of the high frequency signal characteristics, recognizing of course the intermittent character of the high frequency events, followed by lower rate acquisition samples to document the lower frequency components of the u and w signals.

Following the completion of the data acquisition and storage, the Vorcom will switch to the self-check mode while the data is transferred from the buffer to magnetic tape. The self-check mode executes two general procedures to evaluate the fidelity of the processing mode. First, it sequentially removes the contents of each random-access-memory (RAM) location, stores the contents in a temporary location, inputs a test value (taken from a random number generator), reads the test value, and compares the latter with the former. If the results of the last step indicate agreement between the two values, then that location of the RAM is operating properly and the process is continued until all locations are evaluated. If a faulty location is discovered, the Vorcom will halt with an appropriate front panel display to signify the problem. Secondly, digital values simulating the wire voltages are input to the processing unit, and the output values are calculated and compared with the correct values. This check insures the correct operation of the circuit, but at a restricted number of RAM unit memory locations. In combination, these two checks evaluate the parts of the processing circuit which are most vulnerable to failure.

## 5. SUMMARY

The documentation of the mean flow field has been achieved, Foss [1974 a], and the results of this study suggest alterations in the experimental procedures for the continuing work. The modified research program is in progress; this report has identified the motivation for and the characteristics of these new activities. Of particular significance is the development of a unique digital electronics processor to rapidly and accurately compute the streamwise and vertical velocity components and the transverse vorticity. The experimental facility modifications are also presented.

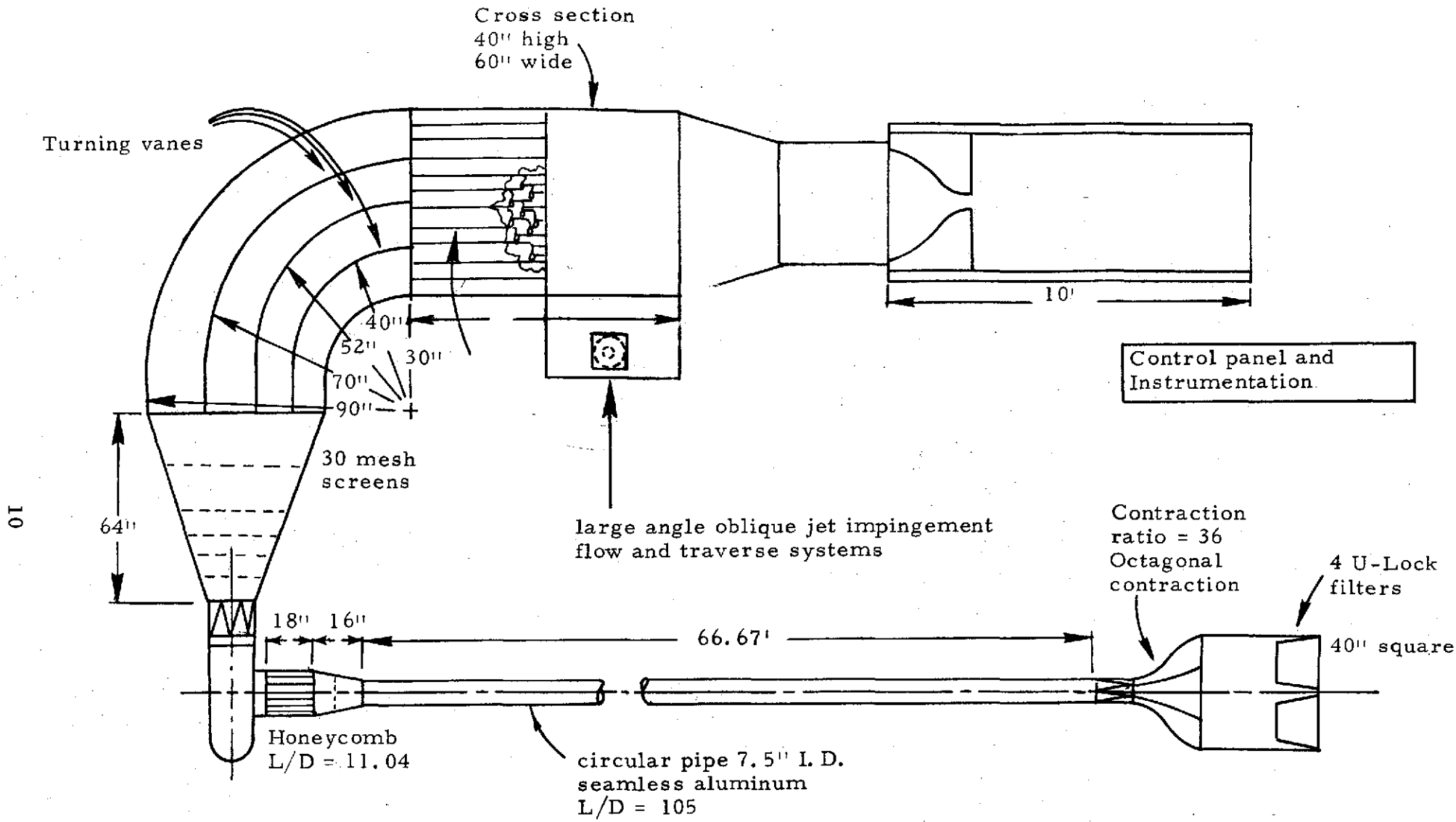
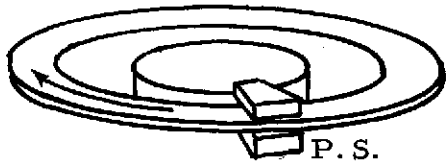

Figure 1a. Schematic of laboratory.





Rotary table attachment for angular position sensor

P.S.

Note: The impact plate is attached to surface A (see Figure 2b).

P.S.: Photocell position sensor (see Figure 3).

12

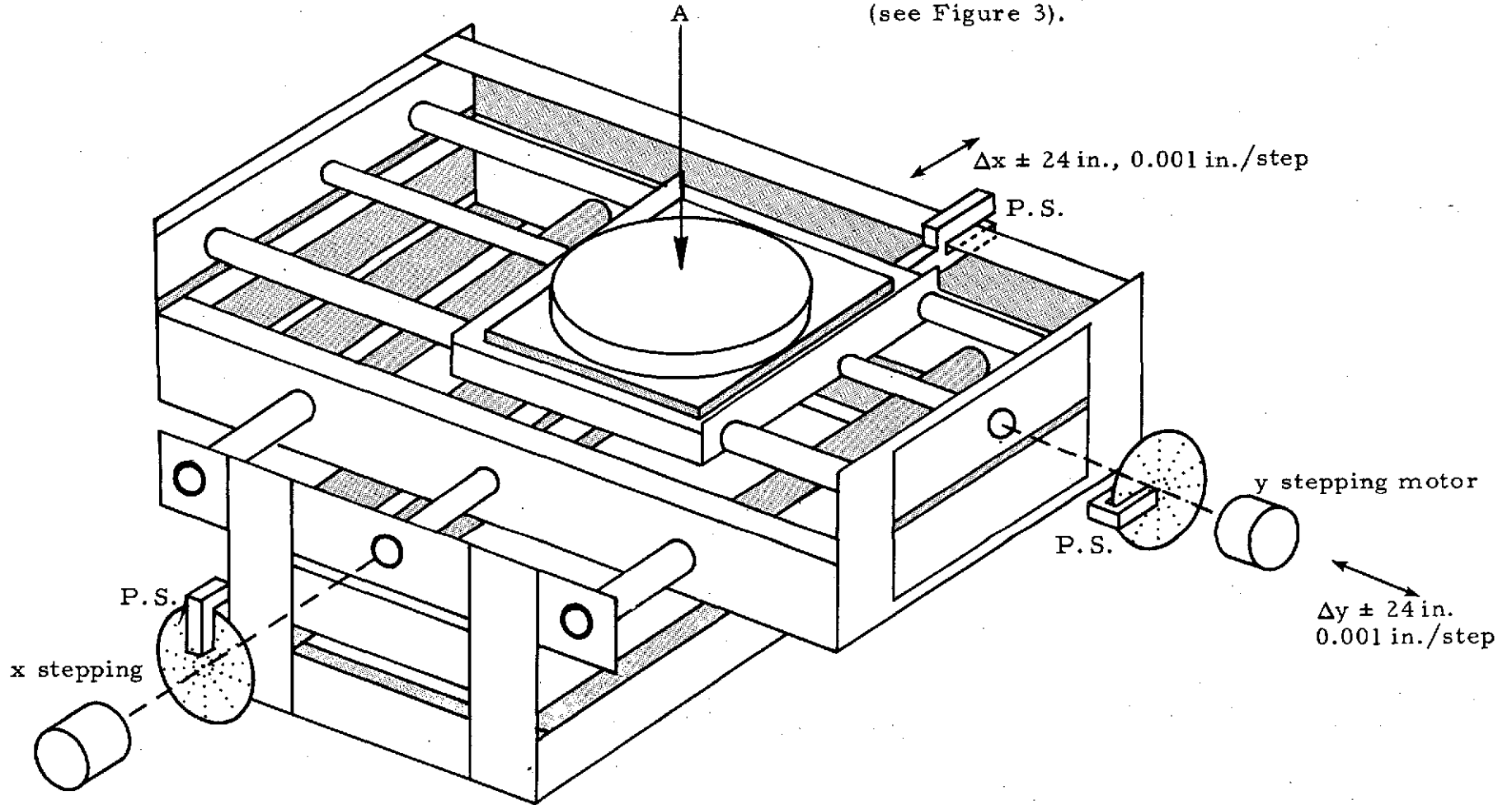

Figure 2a. The x, y,  $\theta$  traverse device.

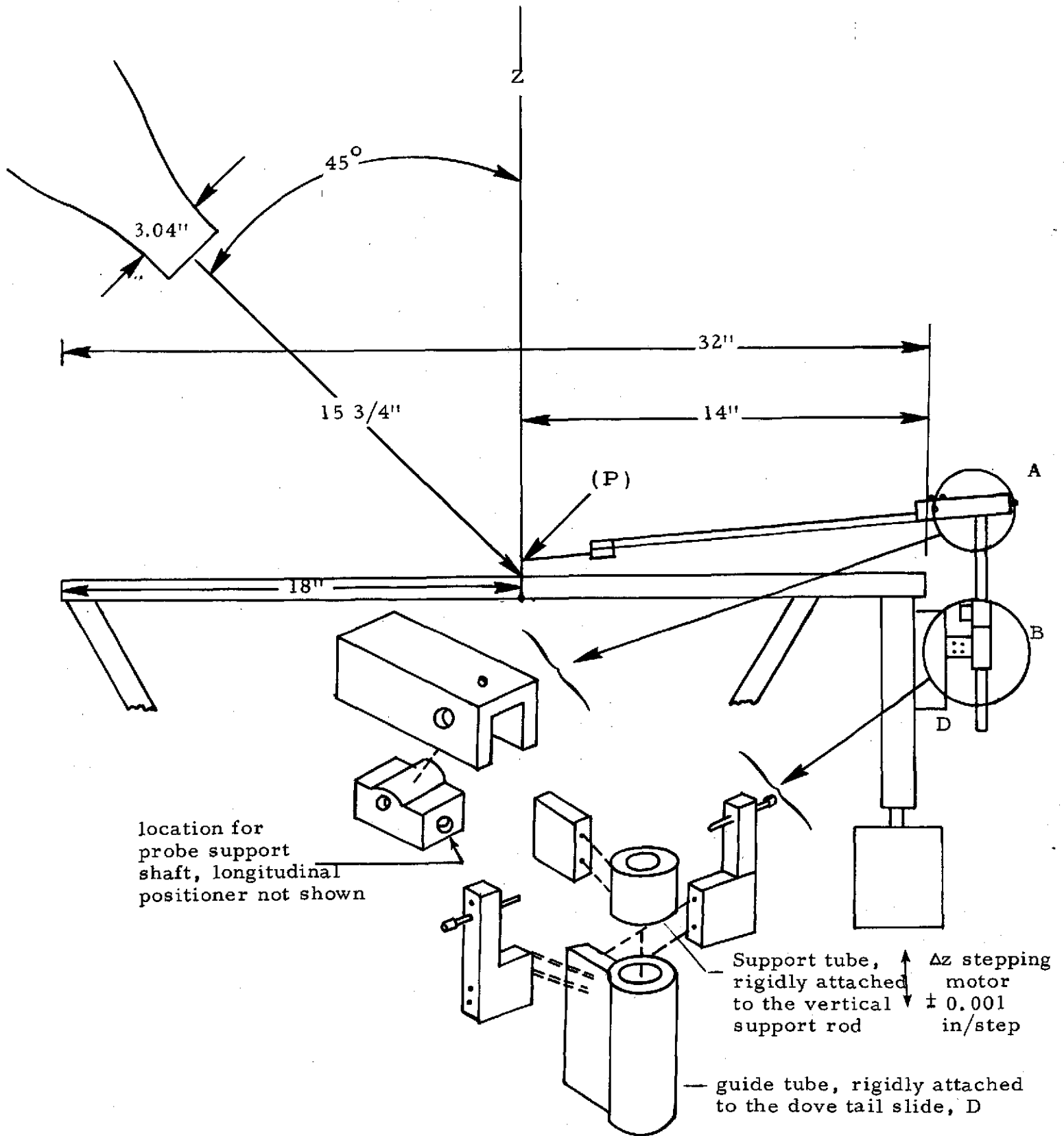
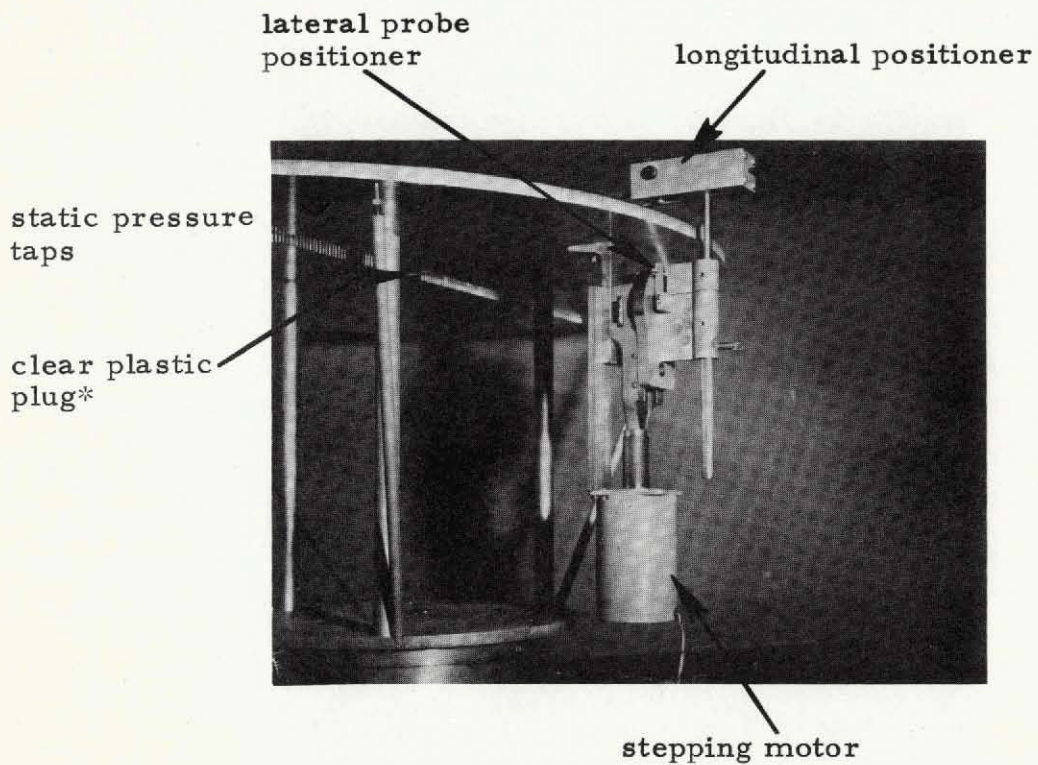
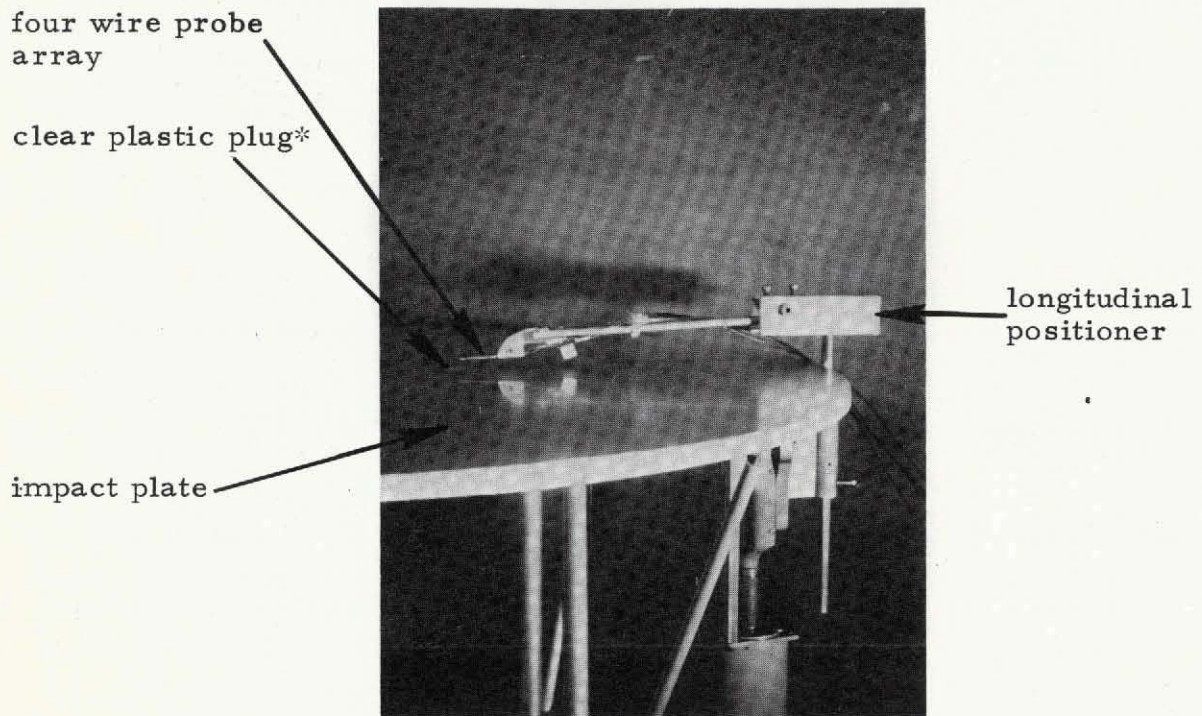

Figure 2b. Upper plate and jet. Detail A shows the mechanism to allow longitudinal and pitch angle positioning of the probe (P). Detail B shows the yaw angle positioner. These three adjustments are sufficient to locate the probe tip over the rotation axis of the plate.



\*Clear plastic plug is to reduce surface heat transfer from hot wire which would cause erroneous signals for small z positions

Figure 2c. Probe position mechanism



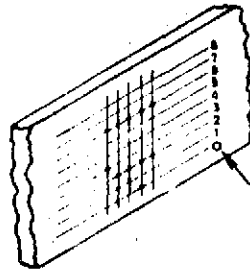

Encoded shaft showing the numbers 68 to 72 (R→L); the dot signifies an open hole for the passage of a light signal

Bit No.

L = Light source  
P = Photo diode  
EC = Encoded shaft

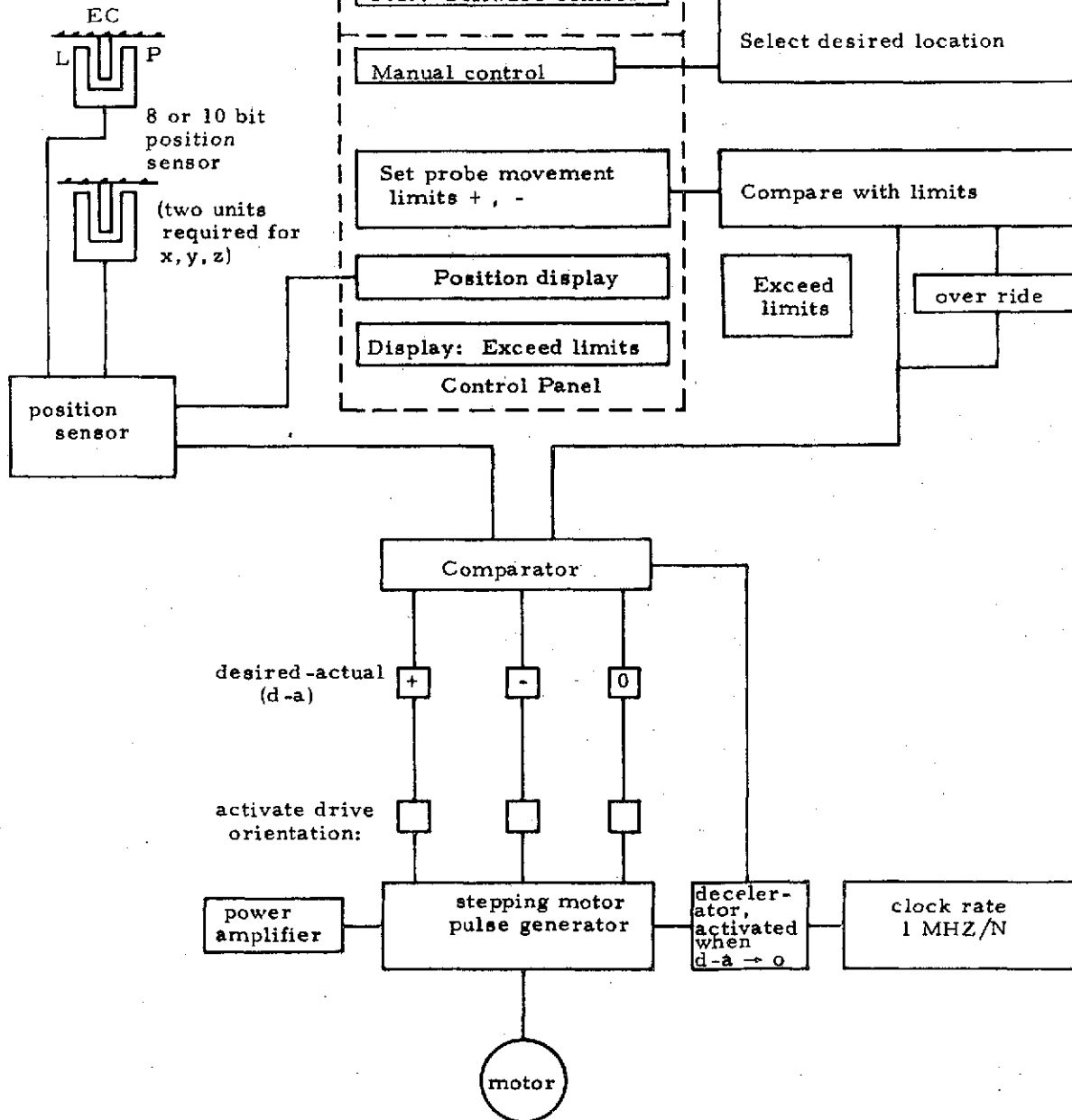
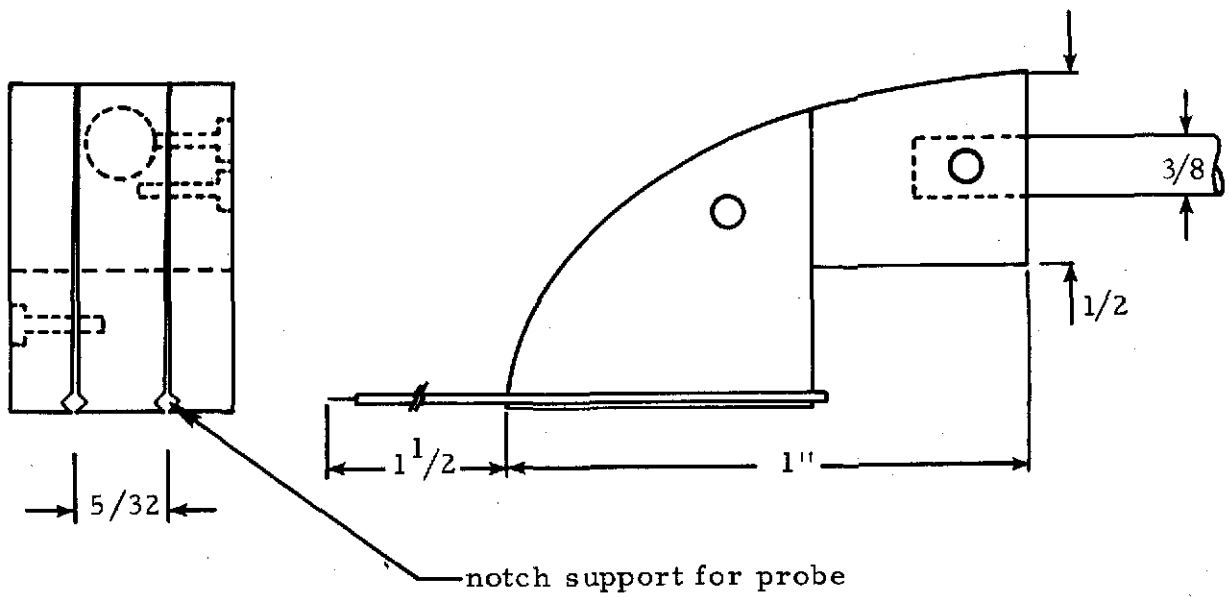
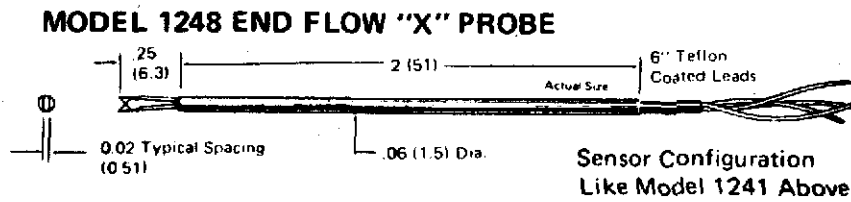

Figure 3. Schematic of position control sub-system;  
Note: One sub-system for each position: x, y, z,  $\theta$   
; N will be selected to obtain the maximum stepping rate per  
the torque requirements of the individual position control circuit



a. Probe support.



b. Detail of x-probe.

Note: The  $\Delta u/\Delta z$  probe is similar to this--the parallel single wires replace the x-configuration.

Figure 4. Vorticity probe.

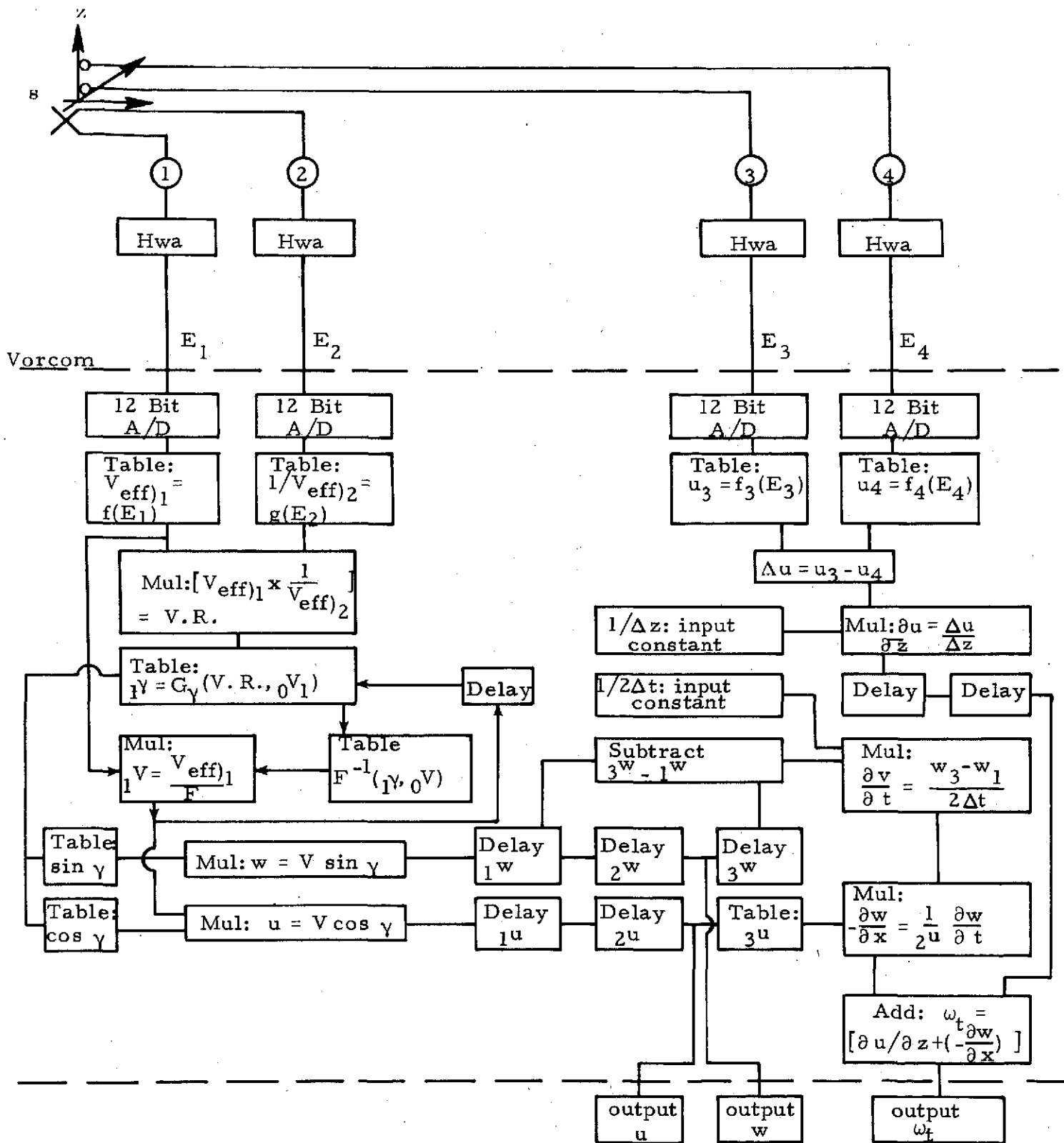

Figure 5. Schematic of hard wire digital data processor to compute the velocities and the transverse vorticity

- Note: 1)  $i$  -  $i^{th}$  time step with respect to the  $(100/N)$  khz reading rate  
 2) The weak dependence of  $F$  and  $G$  on  $V$  are accounted for by utilizing  $V$  from the previous time step.

## 6. REFERENCES

- Bunn, H. H., [1971] "Interpretation of a hot-wire signal using a universal calibration law," *Jour. Phys. E., Sci. Instr.*, Vol. 4, pp. 225-231.
- Chmielewski, G. E., [1974] "Boundary layer considerations in the design of aerodynamic contractions," *Jour. Aircraft*, Vol. 11, No. 8, pp. 435-438, August.
- Foss, J. F., [1974a] "Measurements in a large angle oblique jet impingement flow," Third Year Tech. Report, Part 1, NASA Lewis Research Center, January.
- Foss, J. F., [1974b] "Vorticity effects in a large angle oblique jet impingement flow," Second Interagency Symposium on University Research in Transportation Noise, North Carolina State University, Vol. 1, p. 264, June.
- Fujita, H. and L. S. G. Kovasznay, [1968] "Measurements of Reynolds stress by a single rotated hot-wire anemometer," *Rev. of Sci. Instr.*, Vol. 39, No. 9, pp. 1351-1355.
- Hardin, J. C., [1973] "Analysis of noise produced by an orderly structure of turbulent jets," NASA TN D-7242, April.
- Hinze, J. O., [1959] Turbulence, McGraw Hill, New York, 1959.
- Webster, C. A. G., [1962] "A note on the sensitivity to yaw of a hot-wire anemometer," *Jour. Fluid Mech.*, Vol. 13, pp. 307-312.