

NASA TECHNICAL NOTE



NASA TN D-7875

NASA TN D-7875

LANDING-IMPACT STUDIES
OF A 0.3-SCALE MODEL
AIR CUSHION LANDING SYSTEM
FOR A NAVY FIGHTER AIRPLANE

Trafford J. W. Leland and William C. Thompson

Langley Research Center

Hampton, Va. 23665



1. Report No. NASA TN D-7875	2. Government Accession No.	3. Recipient's Catalog No.	
4. Title and Subtitle LANDING-IMPACT STUDIES OF A 0.3-SCALE MODEL AIR CUSHION LANDING SYSTEM FOR A NAVY FIGHTER AIRPLANE		5. Report Date March 1975	6. Performing Organization Code
		8. Performing Organization Report No. L-9978	
7. Author(s) Trafford J. W. Leland and William C. Thompson		10. Work Unit No. 505-08-31-01	11. Contract or Grant No.
9. Performing Organization Name and Address NASA Langley Research Center Hampton, Va. 23665		13. Type of Report and Period Covered Technical Note	
		14. Sponsoring Agency Code	
12. Sponsoring Agency Name and Address National Aeronautics and Space Administration Washington, D.C. 20546			
15. Supplementary Notes Technical film supplement L-1168 is available on request.			
16. Abstract <p>An experimental study was conducted in order to determine the landing-impact behavior of a 0.3-scale, dynamically (but not physically) similar model of a high-density Navy fighter equipped with an air cushion landing system. The model, furnished by the United States Naval Ship Research and Development Center, was tested over a range of landing contact attitudes at high forward speeds and sink rates on a specialized test fixture at the Langley aircraft landing loads and traction facility. The investigation indicated that vertical acceleration at landing impact was highly dependent on the pitch angle at ground contact, the higher acceleration of approximately 5g occurring near zero body-pitch attitude.</p> <p>A limited number of low-speed taxi tests were made in order to determine model stability characteristics. The model was found to have good pitch-damping characteristics but stability in roll was marginal.</p>			
17. Key Words (Suggested by Author(s)) Aircraft landing Air cushion landing system Impact studies		18. Distribution Statement Unclassified - Unlimited New Subject Category 05	
19. Security Classif. (of this report) Unclassified	20. Security Classif. (of this page) Unclassified	21. No. of Pages 33	22. Price* \$3.75

LANDING-IMPACT STUDIES OF A
0.3-SCALE MODEL AIR CUSHION LANDING SYSTEM
FOR A NAVY FIGHTER AIRPLANE

Trafford J. W. Leland and William C. Thompson
Langley Research Center

SUMMARY

An experimental study was conducted in order to determine the landing-impact behavior of a 0.3-scale, dynamically (but not physically) similar model of a high-density Navy fighter equipped with an air cushion landing system. The model, furnished by the United States Naval Ship Research and Development Center, was tested over a range of landing contact attitudes at high forward speeds and sink rates on a specialized test fixture at the Langley aircraft landing loads and traction facility. The investigation indicated that vertical acceleration at landing impact was highly dependent on the pitch angle at ground contact, with the higher acceleration of approximately 5g occurring near zero body-pitch attitude.

A limited number of low-speed taxi tests were made in order to determine model stability characteristics. The model was found to have good pitch-damping characteristics but stability in roll was marginal.

INTRODUCTION

The concept of an air cushion landing system (ACLS) for aircraft has been the subject of many theoretical and experimental programs. Some applications of the ACLS for several different aircraft and mission profiles are summarized in reference 1. One of the more challenging of the applications was a study (ref. 2) conducted by the United States Naval Ship Research and Development Center (NSRDC) in order to determine the feasibility of installing an ACLS on a high-density Navy fighter and still retain carrier-landing capability at high forward speeds and high sink rates. The feasibility study appeared promising enough to expand the program to include model studies. Accordingly, a 0.3-scale, dynamically (but not physically) similar model of a high-density Navy fighter was constructed under contract to the NSRDC by Bell Aerospace Company with an air cushion landing system of Bell's design. The scaling is based on presently accepted state of the art. Static testing at the NSRDC revealed a serious trunk-flutter problem.

This problem was eventually cured through the installation of an external ridge or strake on the trunk near the ground-tangent line and by adding mass in the form of shot-filled pouches placed near the center of the trunk. At the conclusion of the static testing, the model was sent to Langley Research Center at the request of the Navy and was installed on a specialized ACLS test fixture at the Langley aircraft landing loads and traction facility for landing-impact tests at combined high sink rate and high forward speed.

The purpose of this paper is to present the results of those tests, together with results of some low forward-speed taxi tests in order to determine model stability characteristics. The simulated landings were conducted at one nominally scaled landing speed over a range of contact attitudes and sink rates. Time history and maximum value data are presented, and a motion-picture film supplement (L-1168) is available on request.

SYMBOLS

Values are given first in the International System of Units and parenthetically in U.S. Customary Units. The measurements and calculations were made in U.S. Customary Units.

IGE	in ground effect
OGE	out of ground effect
p_c	cavity pressure, kPa gage (psig)
p_t	trunk pressure, kPa gage (psig)
V_H	horizontal velocity, m/s (ft/sec)
V_V	vertical velocity, m/s (ft/sec)
α	body pitch attitude, deg
$\dot{\alpha}$	pitch velocity, deg/sec
ϕ	body roll attitude, deg
$\dot{\phi}$	roll velocity, deg/sec
ψ	body yaw attitude, deg

APPARATUS AND TEST PROCEDURE

General

Tests of the 0.3-scale model Navy fighter equipped with an air cushion landing system (ACLS) were conducted at the Langley aircraft landing loads and traction facility. The facility, shown schematically in figure 1 and described in detail in reference 3, basically consists of a test carriage which rides on rails spaced 9.1 m (30 ft) apart for the total length of 670 m (2200 ft). A large water-jet catapult can provide up to 2000 kN (450 000 lbf) thrust to accelerate the carriage to a desired test speed. Following a coasting period, during which the test is accomplished, the carriage is brought to a stop by an arresting cable system. As shown in figure 1, a smooth-surface level runway, 168 m (550 ft) long and 2.4 m (8 ft) wide, was provided especially for the ACLS model testing.

Model Support Fixture

A support fixture was developed especially for the ACLS model testing, and is shown attached to the front of the test carriage in the photograph of figure 2. Some of the operational features of this fixture are shown schematically in figure 3. The model is attached to the fixture at the model's center of gravity (c.g.) through a set of gimbals which allow freedom in pitch and roll. These gimbals form the bottom of a heave pole, as shown in figure 3. The heave pole is restrained by two sets of linear ball bushings in order to provide model freedom in vertical motion, or heave. The ball bushings are, in turn, carried in ball bearings attached to the head in order to provide model freedom in yaw. Hydraulic disk-brake assemblies are provided at the top of the heave pole and at each gimbal, as shown, to allow prepositioning of the model attitude before catapult. A trailing-arm switch located at the back of the model releases the brakes at ground contact. Limit switches are also provided to activate these brakes in case of extreme model excursions. In order to simulate wing lift at landing impact, a pneumatic cylinder, acting through a trunion bearing, exerts a constant up force on the heave pole and thus on the model. In these tests, the cylinder pressure was adjusted to provide a lift force equal to the weight of the model and was held constant during the impact phase. It is recognized that, on the full-scale aircraft, the lift force changes rapidly during the extreme attitude changes following impact. However, the degree of sophistication necessary to provide an attitude lift-force feedback system was considered beyond the scope of this test program.

The desired vertical velocity at impact was achieved by a free drop of the model and boom assembly from a predetermined height. The parallel-arm boom was locked at this height by the bomb-shackle arrangement shown in figure 3. At the desired impact

point on the runway, the shackle was released by a limit switch actuated by a knife edge. Internal hydraulic shock absorbers limited the down travel of the boom. When these absorbers were engaged, the wing-lift cylinder was released so that the model impacted the runway with full wing lift.

Model Scaling

The ACLS model, as furnished by the Navy to the Langley Research Center for testing, was a 0.3-scale, dynamically (but not physically) similar model of a high-density Navy fighter. The model was dynamically similar in that the linear dimensions of the lower fuselage, and the weights and moments of inertia of the entire airplane, were reproduced in a scale proportional to the prototype. The model was not physically similar (as shown in photographs of figs. 4 and 5), since no aerodynamic surfaces were represented in what was essentially a rigid "boilerplate" model, intended to be dynamically similar in response to ground loads only. The scaling of the air cushion system itself is less certain, since complete dynamic similarity can be achieved only by maintaining geometric similarity, the ratio of the inertia forces to the viscous forces, and the ratio of the inertia forces to the gravity forces. Although the geometry and linear dimensions of the ACLS were accurately scaled, Froude scale relationships, as in table I, were used in order to maintain the highly dominant inertia to gravity-force ratio, and thus the inertia to viscous-force ratio was compromised. The effect of this compromise, which is not a simple Reynolds number correction, cannot be predicted since there are some compressibility effects, particularly during the landing impact, in the trunk and air cushion system.

Furthermore, because of practical limitations, several other full-scale parameters were not strictly scaled in the tests. These are chiefly the atmospheric pressure in which the tests were conducted, the total air-supply characteristics (fan pressure and fan flow) and the elastic trunk characteristics envisioned for the prototype. Thus, although the model tests described in subsequent sections may serve as a useful quantitative guide to some ACLS characteristics, caution should be exercised in extrapolating model behavior to prototype behavior, and no such attempt is made in this paper.

Model Description

The schematic of figure 6 shows the general arrangement and some pertinent dimensions of the model as used in this investigation. Some model characteristics are summarized in table II. In table II gage pressures were used, rather than absolute pressures, since the tests were primarily concerned with flow rather than with compression phenomena. The body of the model was rigidly constructed of heavy aluminum channel, and the trunk, shown inflated in the closeup of figure 7, was constructed of an inelastic rubberized fabric having bonded and sewn seams. Pressurized air was furnished by two axial fans

with integral 11.2-kilowatt electric motors arranged in series as shown in figure 6. Since the fan motors were driven at a constant speed by a fixed-frequency diesel-motor generator onboard the carriage, scaled pressure-flow requirements were achieved by partially blocking the inlet of the leading fan. Air from the fans was directed into the trunk through the duct shown in figure 6.

As originally configured, the trunk had a total of 3600 peripheral jet holes 0.25 cm (0.097 in.) in diameter distributed around the ground tangent (fig. 7) and 128 cavity vent holes 1.27 cm (0.5 in.) in diameter. These holes were blocked off as required in order to establish the desired relationship between the trunk pressure, the cavity pressure, and the fan flow. The final values of the trunk and cavity-discharge vent areas are shown in table II.

Instrumentation

The extensive instrumentation used in this investigation required the use of two 18-channel direct-write oscillographs installed on the test carriage. In order to provide an accurate correlation of the data from the two recorders, two common channels were provided. One channel was the output of a time-code generator, and the other was the output from a photocell device which marked the test carriage position at 3.05-m (10-ft) intervals throughout the test section. The model instrumentation included a total of four trunk-pressure gages located at the leading- and trailing-edge centers of the trunk, and in the approximate center of each side. Cavity pressures were measured at the forward and aft end of the cavity through the bottom of the fuselage. The output of each fan was monitored by static-pressure pickups located directly behind the fan. Circular potentiometers located at each gimbal measured the model pitch, roll, and yaw attitudes. Linear slide-wire potentiometers were used to measure the vertical displacement of the heave pole with respect to the head, and vertical displacement of the head with respect to the carriage. Accelerometers were located to measure vertical accelerations at the center of gravity as well as body pitch, roll, and yaw accelerations. A pressure gage located in the lift cylinder monitored the lift force applied to the model. Pressure gages in the attitude-brake lines signaled the action of the ground-contact switch.

Test Procedure

Before testing began, the trunk pressure was established as 4.55 kPa gage (0.66 psig) out of ground effect and resulted in approximately 6.07 kPa gage (0.88 psig) in ground effect with full vertical load. Before each test run, the desired model attitude at ground contact was established by using a very sensitive inclinometer; the attitude brakes were engaged to hold this position. The desired drop height was then established by raising or lowering the boom until the lowest point on the inflated trunk was just

touching a gage block. The ground-contact switch was adjusted to the same gage block in order to release the attitude brakes at ground contact.

After the landing-impact simulation studies, a short series of tests was conducted to investigate model stability in pitch and roll. The test procedure differed slightly for these runs, in that no wing-lift force was applied, and the model drop height was reduced to a minimum. These tests were run at a forward speed of 3.0 m/s (10 ft/sec) by use of a carriage-towing tractor for propulsion.

RESULTS AND DISCUSSION

Landing-Impact Studies

General.- In order to show the relationship of the various measurements made on the 0.3-scale ACLS model, an all-channel time history for a typical landing impact is presented in figure 8. To aid in the discussion, the channels have been separated and the appropriate engineering units have been applied. In the figure, time 0 is the point at which the bomb shackle was released and the drop was initiated; ground contact occurred at 0.23 sec as shown. As noted in figure 8(a), the initial pitch attitude for this test was approximately 6° noseup, with yaw and roll attitudes of 0° . The time history of the boom and heave-pole positions illustrates how vertical velocity was achieved by dropping the boom and releasing the heave pole just prior to ground contact. Figure 8(b) shows that the lift-cylinder pressure controlling the wing lift remained essentially constant during impact. The pitch and roll accelerations also shown in figure 8(b) have not been corrected by position to show angular accelerations, although the vertical acceleration is a true linear acceleration. The trunk-pressure gages in figure 8(c) show essentially uniform pressure throughout the trunk, the peak trunk pressure occurring approximately 0.09 sec after impact. In figure 8(b) this is also the time of the peak vertical acceleration. Fan static pressures and cavity pressures are shown in figure 8(d), the cavity pressure reaching a peak approximately 0.18 sec after impact when the pitch attitude is near 0° (fig. 8(a)). The data support the idea that the cavity pressure is at a maximum when the air cushion leakage is at a minimum, as would be the case at 0° . The time lag between the peak trunk pressure and the peak cavity pressure illustrated here was typical for all test runs. It is noted in figure 8(d) that cavity pressures go momentarily negative during rebound, for reasons not known, but the phenomenon occurred fairly consistently for all landing-impact tests. It was thought that the fan static-pressure measurements would give an indication of the fan flow characteristics during impact, but such measurements are obviously unequal to the task in this situation. Since the fan flow plays such an important role in the overall system behavior, particularly in the face of rapidly changing back pressures, further studies must be made to develop techniques for measuring the flow under these conditions. Rather than presenting time histories

for all the remaining landing-impact tests, table III presents a summary of selected parameters. To show trends of these parameters, the following sections depend on table III.

Vertical acceleration.- As shown in figure 9, the maximum vertical acceleration at the model center of gravity appeared to be a strong function of the pitch attitude at ground contact, and to a lesser extent, of the sink rate or the vertical velocity. This figure includes the two runs (runs 13 and 16 in table III) made with combined pitch and yaw angles, since there was no discernible difference in behavior between these runs and those with pitch angle only. The sink rates in the figure have been arbitrarily divided into high sink rates (greater than 1.37 m/s (4.5 ft/sec)) and low sink rates (less than 1.37 m/s (4.5 ft/sec)), and the figure shows a somewhat reduced vertical acceleration at the lower sink rate, as might be expected. Also shown for comparison are the three low forward-speed runs ($V_H = 3.0$ m/s (10 ft/sec)) and the static drop ($V_H = 0$). Figure 9 shows that the maximum acceleration was experienced at a pitch attitude between 2° and 3° , which seems to be in opposition to the idea that the maximum acceleration occurs at 0° . However, as the photograph of figure 5 shows, in the steady-state or hovering situation, the body of the model assumes a slight noseup angle that was found to be approximately 2° . Since the preset pitch attitudes were measured on the body, this implies that the maximum center-of-gravity accelerations were in fact experienced at a near 0° trunk contact attitude. However, the implication also is that body attitudes less than 2° would result in a nosedown contact attitude. Nowhere in the data or motion-picture films is there any evidence suggesting a pitchup motion at ground contact. Figure 10 shows a consistent relationship of a positive, or nosedown, pitch velocity with an increasing pitch attitude, from 0° to 8° . Thus, the anomaly in the pitch-angle data is not explained and may have been caused by a peculiarity of the test fixture or some unknown effects of aerodynamic—air-cushion—ground-effect interaction.

Trunk and cavity pressures.- As previously noted, the time at which the peak trunk pressure was developed during landing impact generally coincided with the time of the maximum vertical acceleration. As shown in figure 11, the trend of the data compares well with figure 9. The static drop is a notable exception, with the peak trunk pressure being much lower than for the forward-speed tests. The relationship between the peak trunk pressure and the maximum vertical acceleration is better illustrated in figure 12, which presents data from all the landing-impact tests, including the asymmetrical landings. The numbers in the figure are keyed to the run numbers in table III, and again the static drop (run 0) is clearly outside the envelope of the forward-speed runs. It is noted in figures 11 and 12 that the peak trunk pressures can reach values nearly twice the design trunk pressure in static hover. This pressure relationship could be of potential significance to ACLS design, since the trunk material, the trunk fastenings, and the pressures and loads into the fuselage could all be affected.

The maximum cavity pressure occurred when the attitude of the model reached essentially 0° following impact, as typified in figure 8, and thus, this pressure occurred somewhat later in time than the peak trunk pressure and the maximum vertical acceleration. As shown in figure 13, a good correlation exists between the peak cavity pressure and the vertical-acceleration level at the time of the peak cavity pressure. Again, the data-point numbers are keyed to the run numbers of table III and include asymmetrical landings. It should be noted that the faired line of figure 13 agrees well with the design cavity pressure in static hover at about the $1g$ acceleration level. The fact that the maximum cavity pressure can rise to nearly four times this value during impact is of interest, since the cavity pressure is directly related to the overall cushion pressure, or bearing pressure, and might be of significance in determining the minimum strength required of a given surface.

Model-Stability Studies

General.- In other air cushion landing system model studies (refs. 1 and 4, for example), certain model ground-stability problems were noted following model perturbations in pitch or roll. A short series of tests were conducted with the present 0.3-scale ACLS model to determine what the stability characteristics would be. The tests were conducted at a low forward speed (3.0 m/s (10 ft/sec)) simulating the taxi condition, and no wing-lift representation was used other than a small amount of lift to offload the model to the correct mass of 326.2 kg (22.4 slugs). The drop height was held to a minimum, less than 7.6 cm (3 in.), and each test was conducted at a constant speed over a distance long enough to establish whether any induced oscillations would damp out or diverge.

Pitch stability.- Time histories of model pitch attitude, vertical acceleration, and trunk and cavity pressures are presented in figure 14 for the three initial pitch contact attitudes of 2° , 4° , and 6° . It can be seen that although an abrupt pitch-down condition is produced, reaching as much as 14° (fig. 14(c)), for an initial contact attitude of 6° , the pitch oscillations dampen out nicely after 3 or 4 cycles. It should be noted that the momentary negative spike in the cavity pressure is even more pronounced here than in the landing impact of figure 8. The motion-picture film supplement gives a good appreciation of model behavior during all the stability tests.

Roll stability.- Time histories of model roll attitude and cavity pressure are presented in figure 15 for initial roll-contact attitudes of 3° and 5° . Here the roll oscillations became extreme, but they did dampen out with time, although small oscillations existed even after the cavity pressure had stabilized at the design hover condition. These results indicate that the model trunk has marginal, although not divergent, roll stability which could cause operational problems if present in the full-scale prototype, although full-scale aerodynamics should have a stabilizing effect.

CONCLUDING REMARKS

A series of landing-impact tests were conducted with a 0.3-scale, dynamically (but not physically) similar model of a high-density Navy fighter equipped with an air cushion landing system. Landings were made at one nominally scaled horizontal velocity and covered a range of ground-contact attitudes and vertical velocities (sink rates).

The results indicated that the maximum vertical acceleration during impact was a strong function of the body pitch attitude, the maximum acceleration of approximately 5g occurring near 0°. The vertical acceleration was reduced to about 3g as the contact attitude was increased to 8°; it also showed some reduction at reduced sink rates. A relationship between the maximum trunk pressure and the maximum vertical acceleration was established, the peak trunk pressure reaching nearly twice the static hover value.

A short series of tests at a simulated low taxi speed with no wing lift showed that the model had reasonably good pitch-damping characteristics after initial perturbations up to 6°. Stability in roll was, however, indicated to be marginal, the slowly damped oscillations persisting even after the cavity pressure had stabilized at hover values.

Langley Research Center,
National Aeronautics and Space Administration,
Hampton, Va., January 29, 1975.

REFERENCES

1. Saha, Hrishikesh, compiler: Air Cushion Landing Systems. Univ. of Tennessee Space Inst., c.1973.
2. Burgan, Elmer I.; and Paddison, Fletcher C.: Surface Effect Takeoff and Landing System (SETOLS). ARPA/T10-74-21, U.S. Dep. Defense, Apr. 1974.
3. Tanner, John A.: Fore-and-Aft Elastic Response Characteristics of 34 × 9.9, Type VII, 14 Ply-Rating Aircraft Tires of Bias-Ply, Bias-Belted, and Radial-Belted Design. NASA TN D-7449, 1974.
4. Thompson, William C.: Landing Performance of an Air-Cushion Landing System Installed on a 1/10-Scale Dynamic Model of the C-8 Buffalo Airplane. NASA TN D-7295, 1973.

TABLE I.- SCALE RELATIONSHIPS

[λ = Scale of model = 0.3]

Quantity	Full-scale value	Scale factor	Model value
Angular acceleration	$\ddot{\alpha}$	λ^{-1}	$\lambda^{-1}\ddot{\alpha}$
Density	ρ	1	ρ
Force	F	λ^3	λ^3F
Length	L	λ	λL
Linear acceleration	a	1	a
Mass	m	λ^3	λ^3m
Moment of inertia	I	λ^5	λ^5I
Pressure, gage	p gage	λ	λp gage
Speed	V	$\sqrt{\lambda}$	$\sqrt{\lambda} V$
Time	t	$\sqrt{\lambda}$	$\sqrt{\lambda} t$

TABLE II.- SOME CHARACTERISTICS OF THE 0.3-SCALE ACLS FIGHTER MODEL

Model parameter	Required value	Actual value
Mass, kg (slugs)	318.4 (21.8)	326.2 (22.4)
Center of gravity:		
Distance from forward face, cm (in.)	152.40 (60.00)	154.31 (60.75)
Distance from bottom fuselage, cm (in.)		21.91 (8.625)
Moment of inertia, kg-m ² (slug-ft ²):		
Pitch	292.8 (216)	301.0 (222)
Roll	40.7 (30)	46.1 (34)
Yaw	318.6 (235)	338.9 (250)
Trunk pressure, OGE, kPa gage (psig)	4.41 (0.64)	4.55 (0.66)
Trunk pressure, IGE, kPa gage (psig)	5.93 (0.86)	6.07 (0.88)
Cavity pressure, IGE, kPa gage (psig)	2.07 (0.30)	2.41 (0.35)
Cavity vent area, cm ² (in ²)		
(45 holes, 1.27 cm (0.5 in.) diam)		57.0 (8.84)
Static cushion area, m ² (ft ²)	1.50 (16.15)	1.31 (14.10)
Trunk vent (jet nozzle) area, cm ² (in ²)		
(2307 holes, 0.25 cm (0.097 in.) diam)		110.0 (17.05)

TABLE III. - A SUMMARY OF RESULTS OF THE MODEL LANDING-IMPACT TESTS

Run	Horizontal velocity, V_H		Vertical velocity, V_V		Nominal body attitude at ground contact, deg			Maximum trunk pressure, $P_{t,max}$ (gage)		Maximum cavity pressure, $P_{c,max}$ (gage)		Maximum vertical acceleration, g units	Pitch or roll velocity, deg/sec	
	m/s	ft/sec	m/s	ft/sec	Pitch, α	Roll, ϕ	Yaw, ψ	kPa	psi	kPa	psi	g units	$\dot{\alpha}$	$\dot{\phi}$
0	0	0	1.25	4.1	0	0	0	6.48	0.94	2.48	0.36	3.5	9	0
1	3.0	10	1.74	5.7	6	0	0	9.86	1.43	6.34	.92	3.4	88	0
2	3.0	10	2.01	6.6	6	0	0	9.38	1.36	6.00	.87	3.5	101	0
3	3.0	10	1.98	6.5	8	0	0	9.17	1.33	4.34	.63	2.8	110	0
4	36.6	120	2.38	7.8	1	0	0	12.14	1.76	8.83	1.28	4.9	19	0
5	35.4	116	2.26	7.4	3	0	0	11.86	1.72	8.62	1.25	5.3	46	0
6	37.2	122	2.07	6.8	4	0	0	12.27	1.78	9.24	1.34	5.1	69	0
7	37.2	122	1.40	4.6	6	0	0	9.31	1.35	4.62	.67	2.9	102	0
8	36.3	119	1.53	5.0	8	0	0	7.52	1.09	4.48	.65	2.4	120	0
*9	34.7	114	1.13	3.7	6	0	0	7.65	1.11	2.14	.31	2.0	78	0
10	35.1	115	1.31	4.3	7	0	0	7.86	1.14	1.59	.23	1.4	90	0
11	35.4	116	1.22	4.0	8	0	0	7.79	1.13	1.38	.20	1.2	90	0
12	37.2	122	1.40	4.6	5	0	0	9.58	1.39	6.55	.95	3.5	74	0
13	37.2	122	1.56	5.1	0	0	5	9.58	1.39	6.34	.92	3.6	11	0
14	36.9	121	1.65	5.4	0	5	0	9.65	1.40	6.55	.95	3.7	23	27
15	35.1	115	1.50	4.9	7	5	0	7.86	1.14	2.76	.40	1.7	106	34
16	34.1	112	1.25	4.1	7	0	5	7.86	1.14	3.10	.45	1.6	96	0
17	36.6	120	1.89	6.2	2	5	5	12.20	1.77	8.62	1.25	4.2	53	33
18	37.2	122	1.74	5.7	4	5	5	11.58	1.68	7.38	1.07	4.4	62	48
19	36.3	119	1.74	5.7	6	5	5	8.83	1.28	4.14	.60	2.6	90	45
20	33.8	111	1.62	5.3	6	5	5	7.03	1.02	2.41	.35	2.0	75	36
21	35.7	116	1.28	4.2	8	6	5	7.10	1.03	2.48	.36	1.2	107	49

*Time history shown in figure 8.

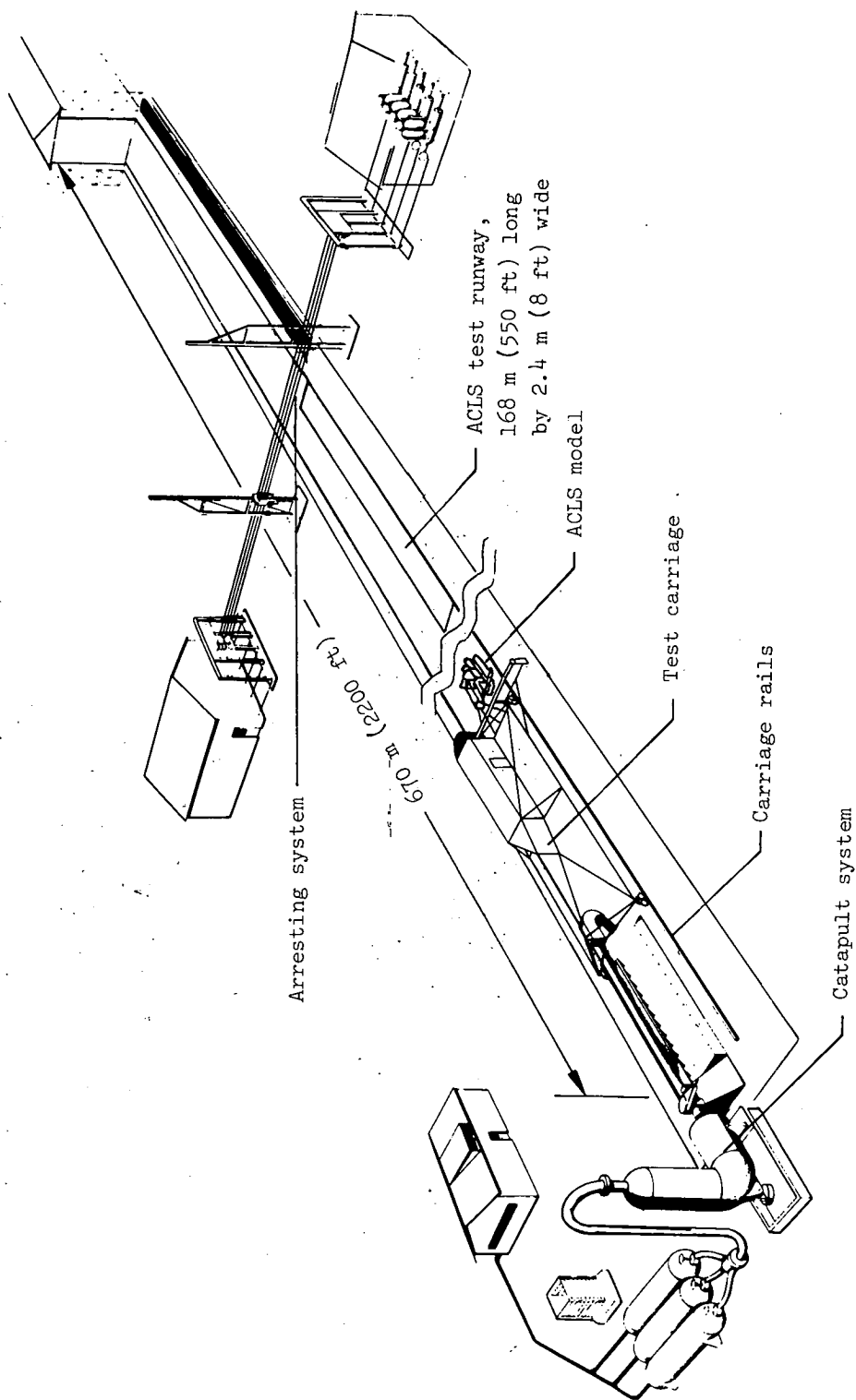

Figure 1.- Schematic of Langley aircraft landing loads and traction facility.



L-73-4007

Figure 2.- Photograph of test carriage with ACLS model installed on special test fixture.

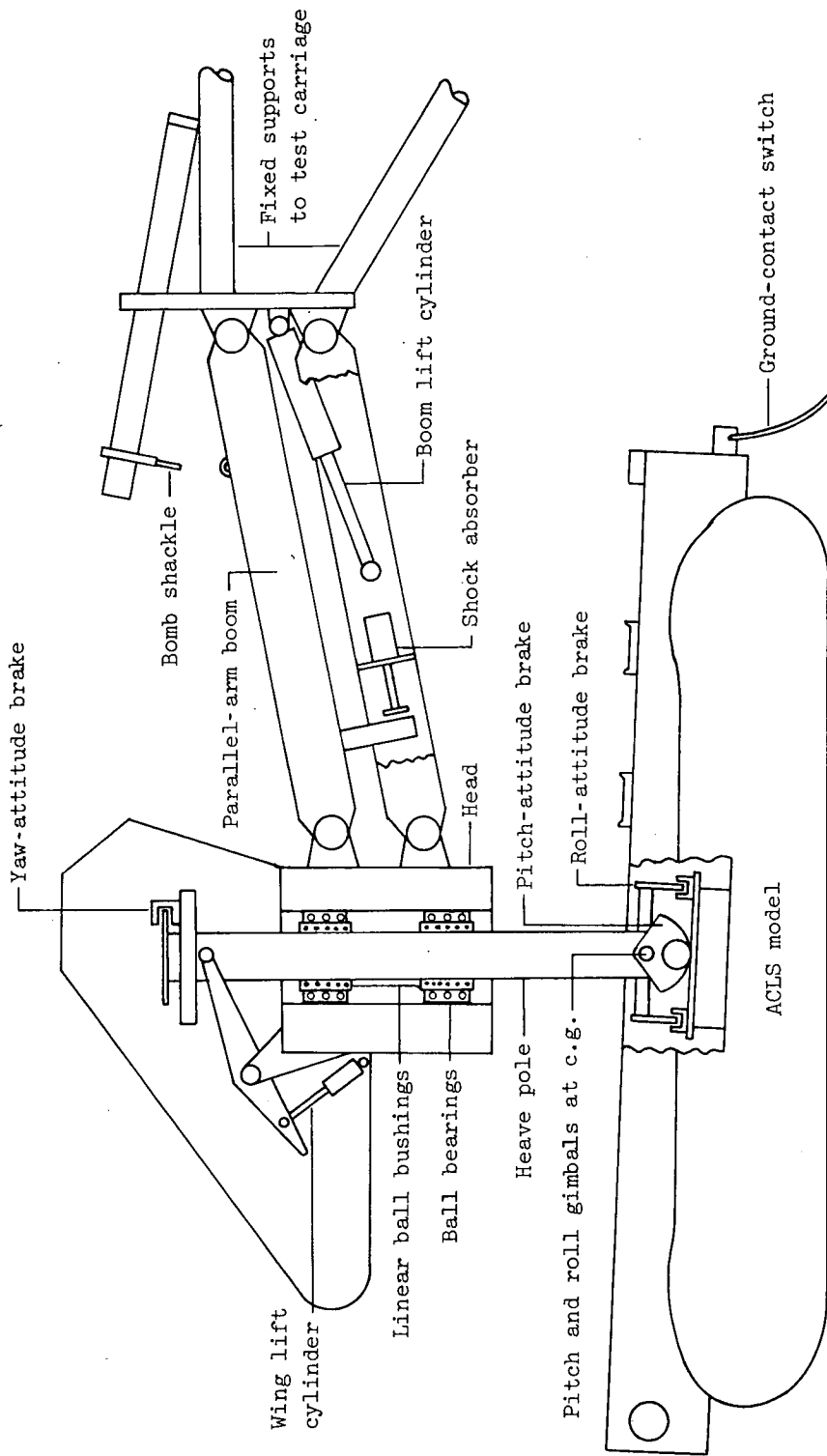
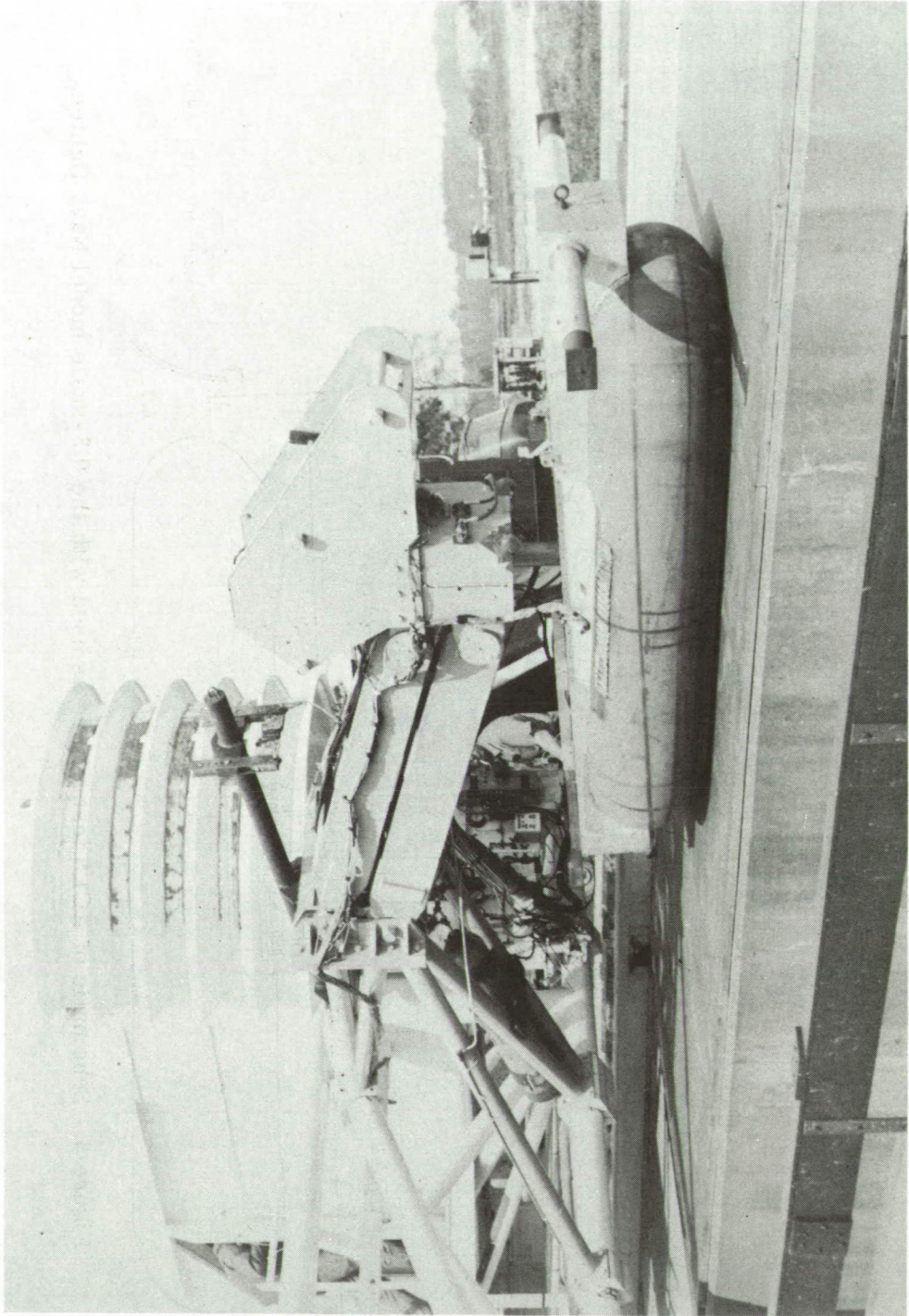
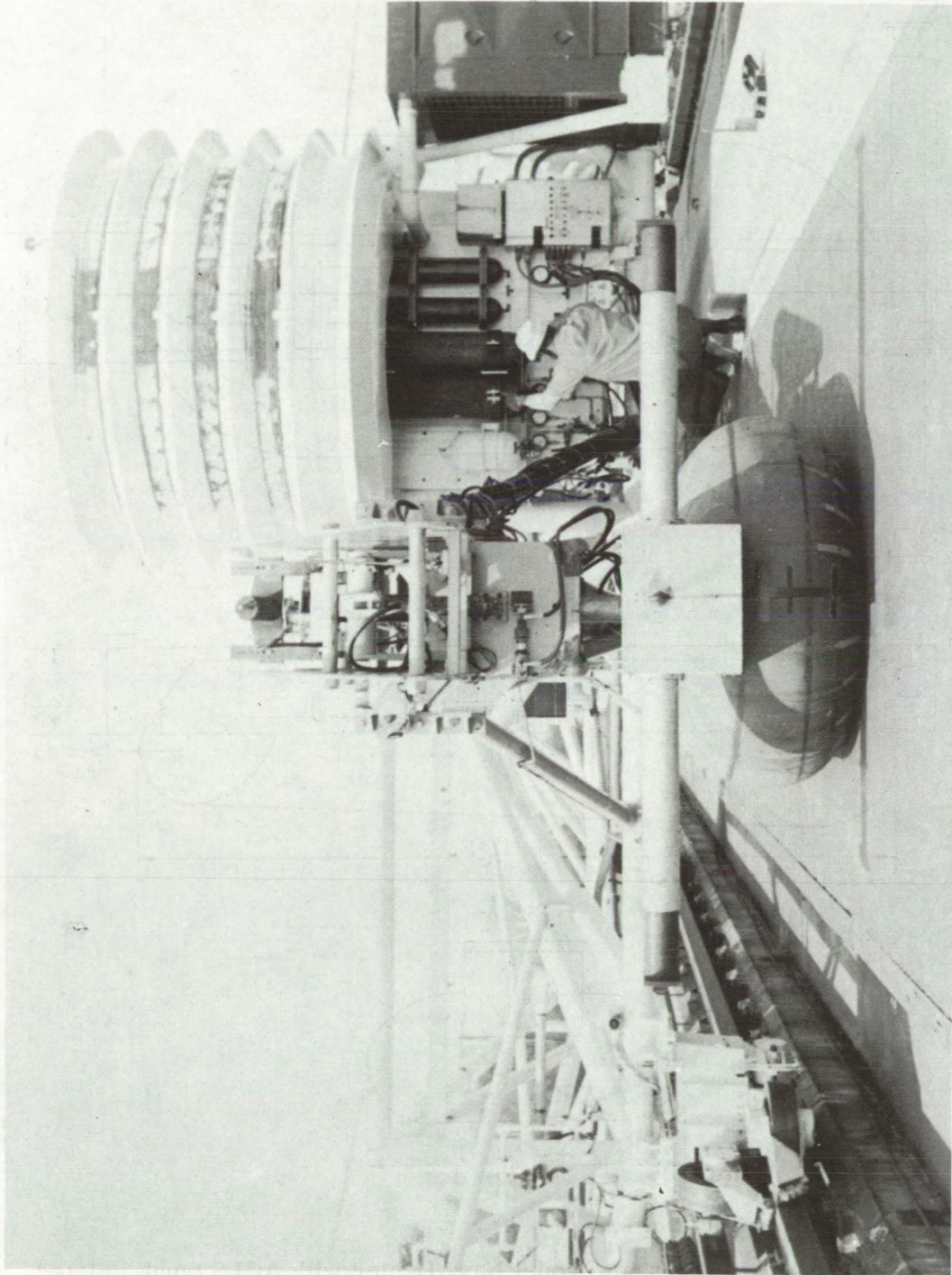

Figure 3.- Schematic of ACLS test fixture as used with the 0.3-scale model Navy fighter.



L-73-2972

Figure 4.- Side view of 0.3-scale model Navy fighter with trunk inflated in static hover.



L-73-2971

Figure 5.- Front view of 0.3-scale model Navy fighter with trunk inflated in static hover.

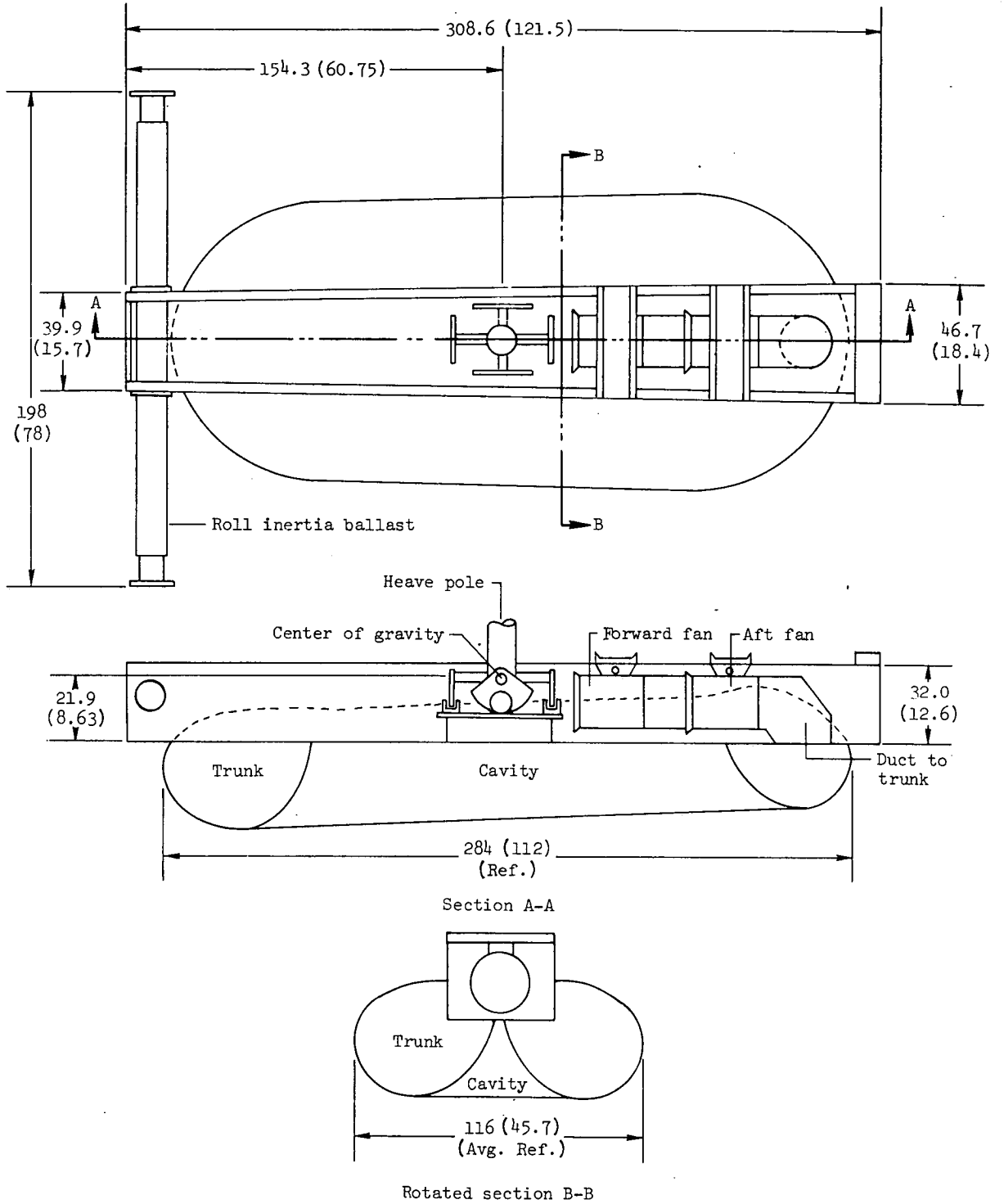
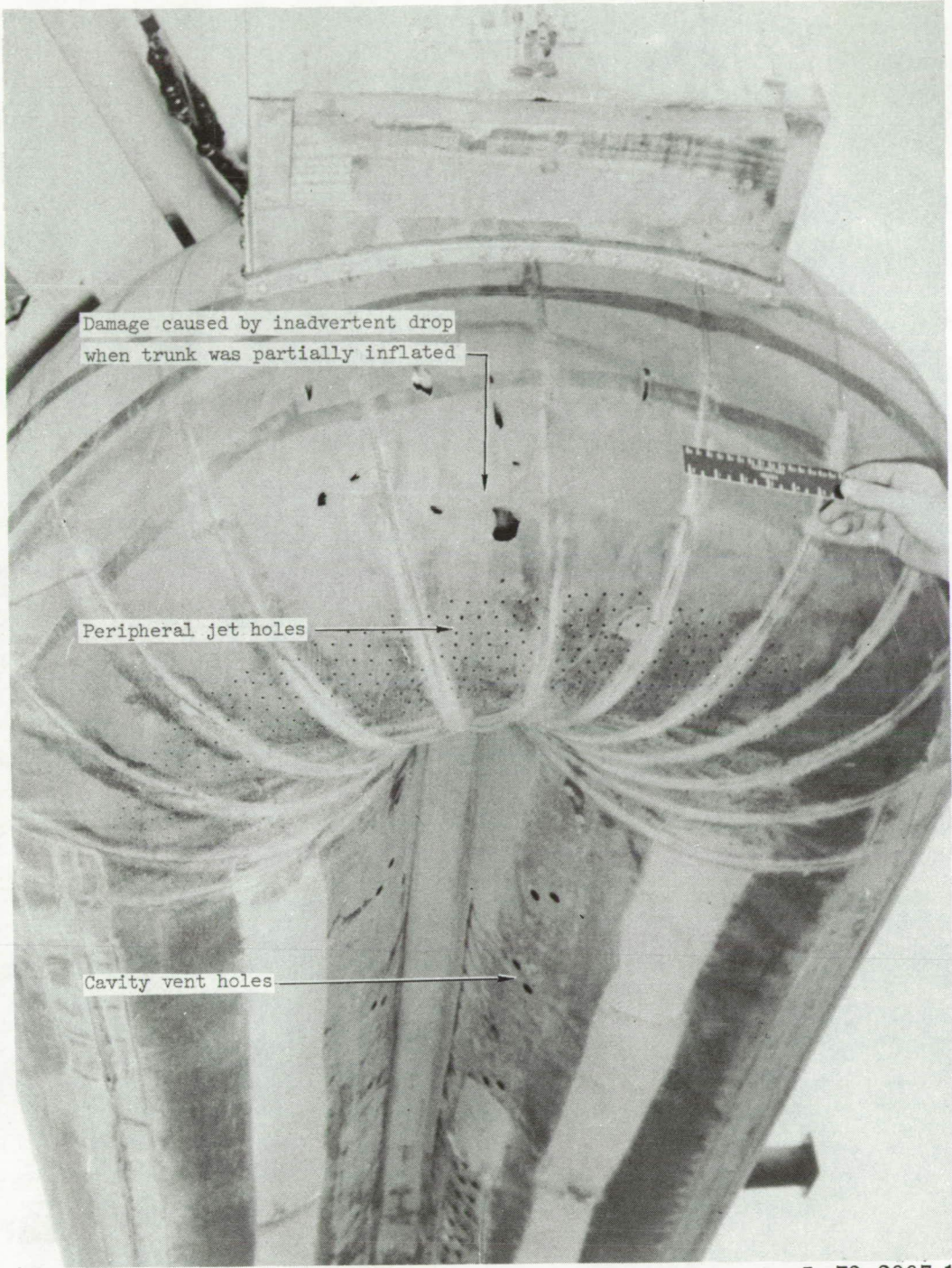
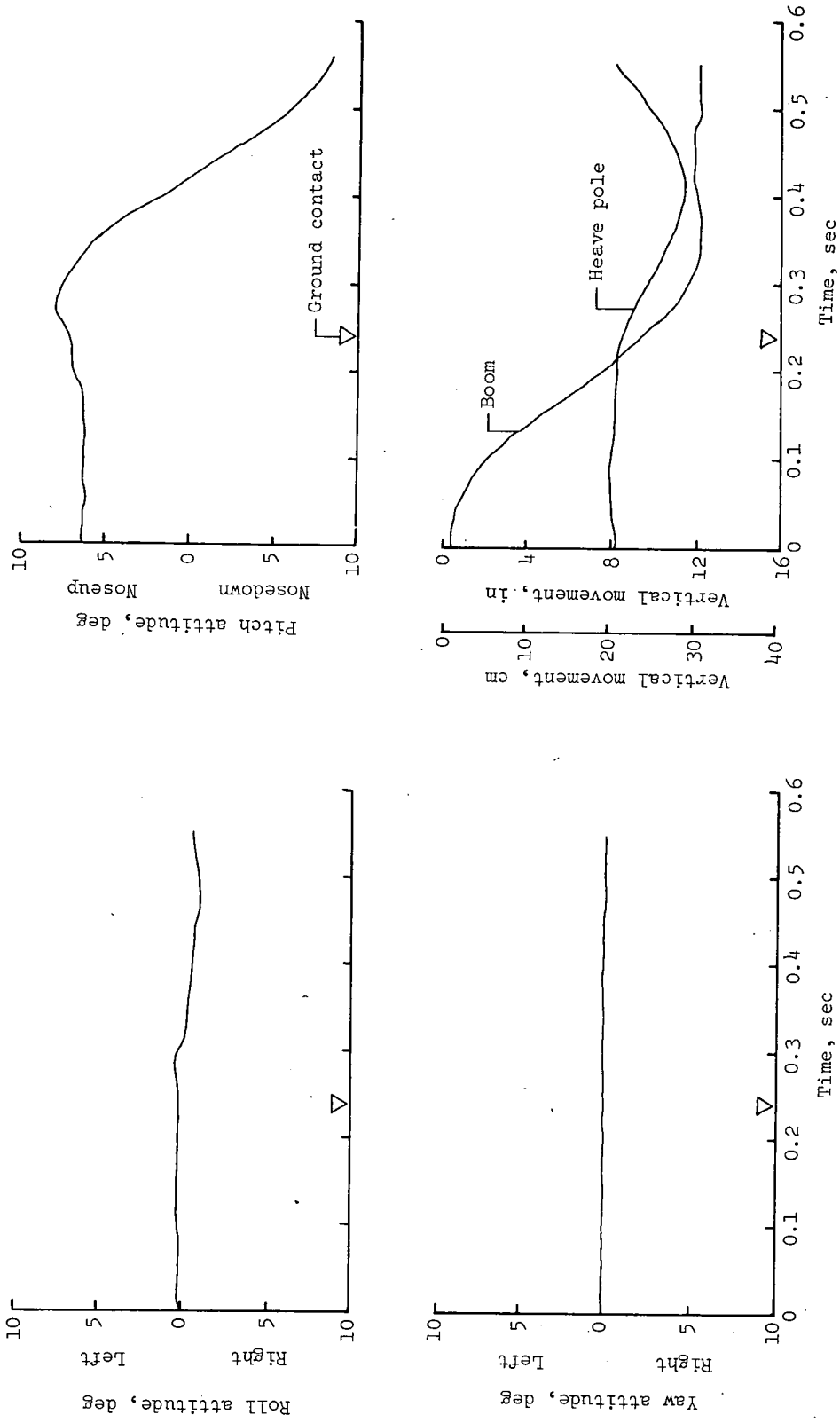

Figure 6.- Schematic of 0.3-scale model Navy fighter with ACLS trunk inflated out of ground effect. Dimensions are in cm (in.).



L-73-2967.1

Figure 7.- Underside of 0.3-scale model Navy fighter with trunk inflated, viewed from aft end.



(a) Model attitudes and vertical position.

Figure 8.- Time history of typical landing impact of 0.3-scale model Navy fighter equipped with ACLS (table III, run 9). At impact, $V_H = 34.7$ m/s (114 ft/sec), $V_V = 1.13$ m/s (3.7 ft/sec).

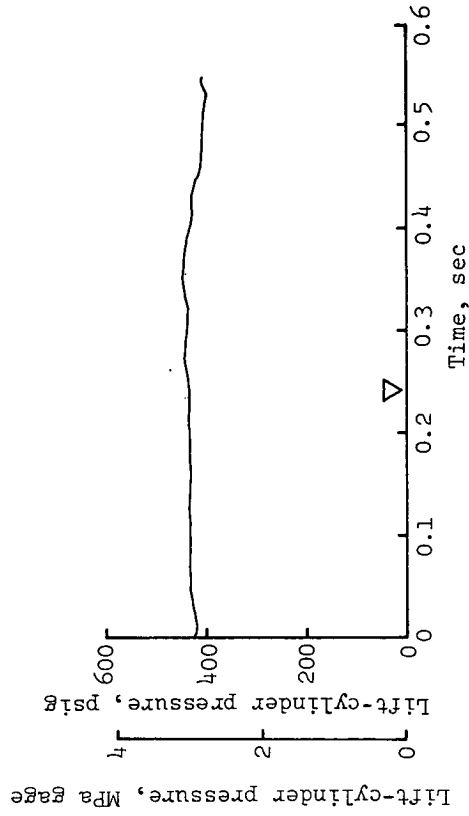
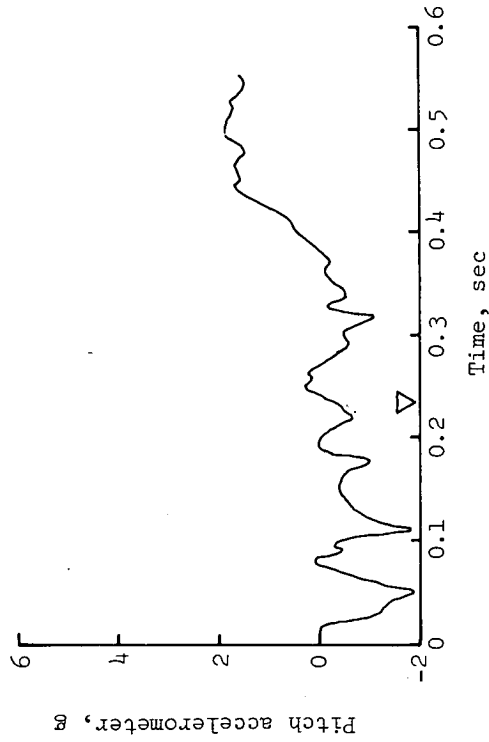
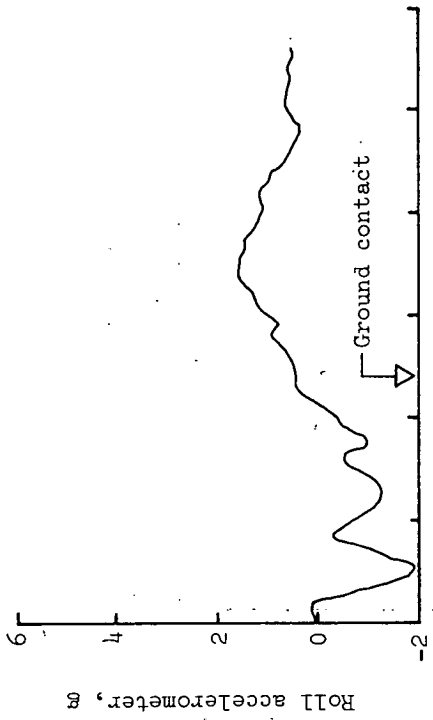
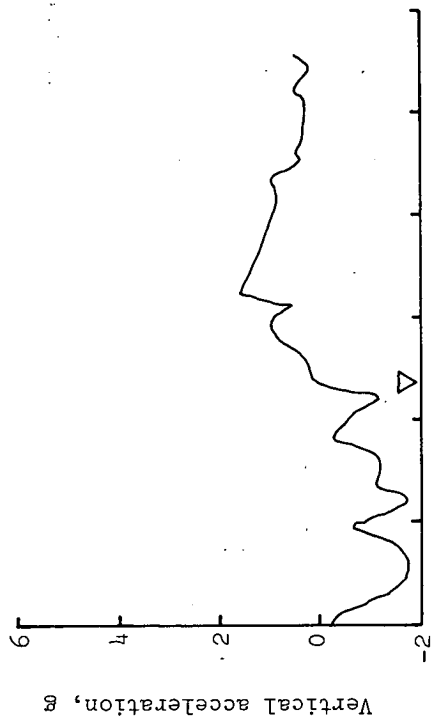

(b) Model accelerations and wing lift.

Figure 8.- Continued.

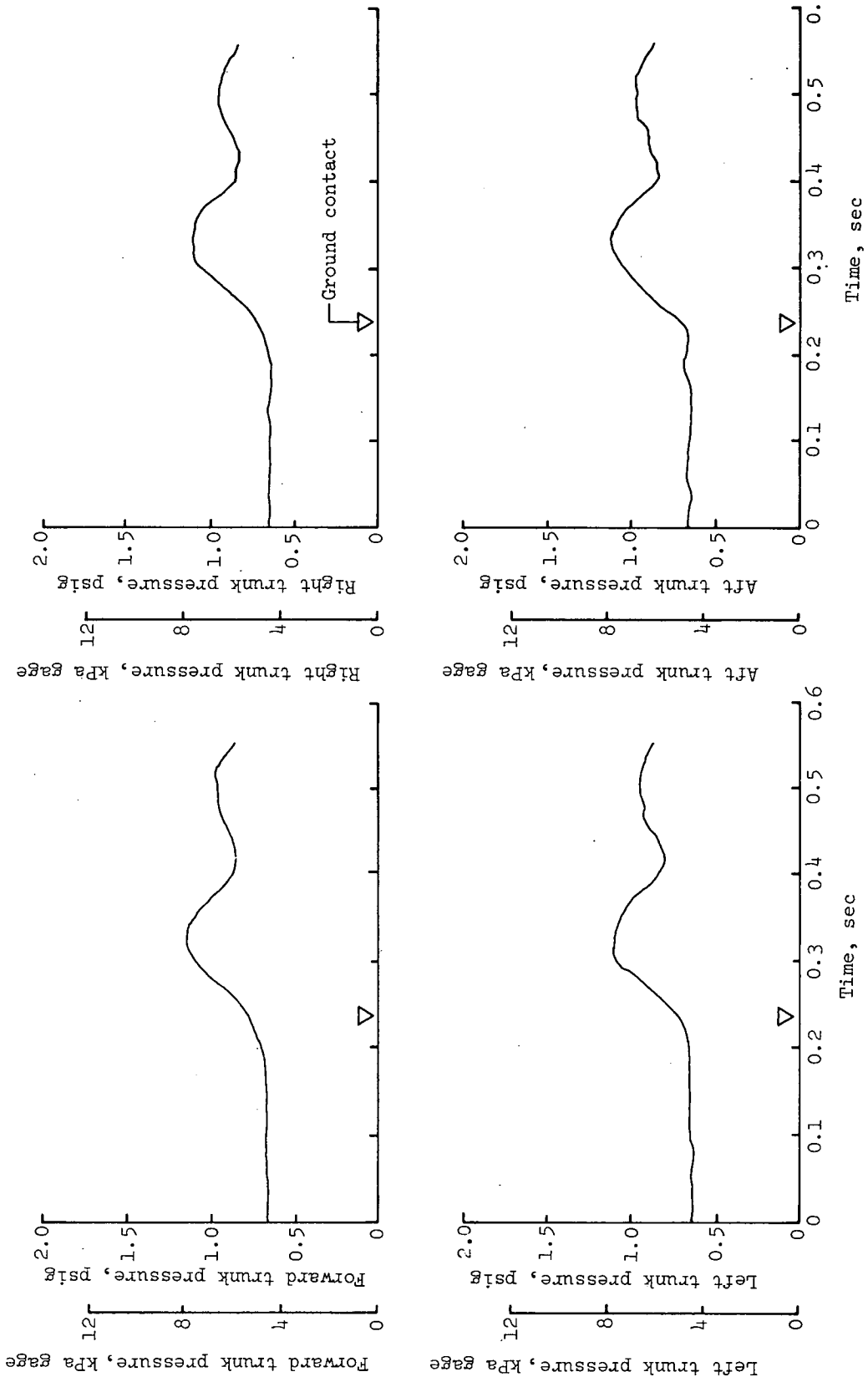

(c) Model trunk pressures.

Figure 8.- Continued.

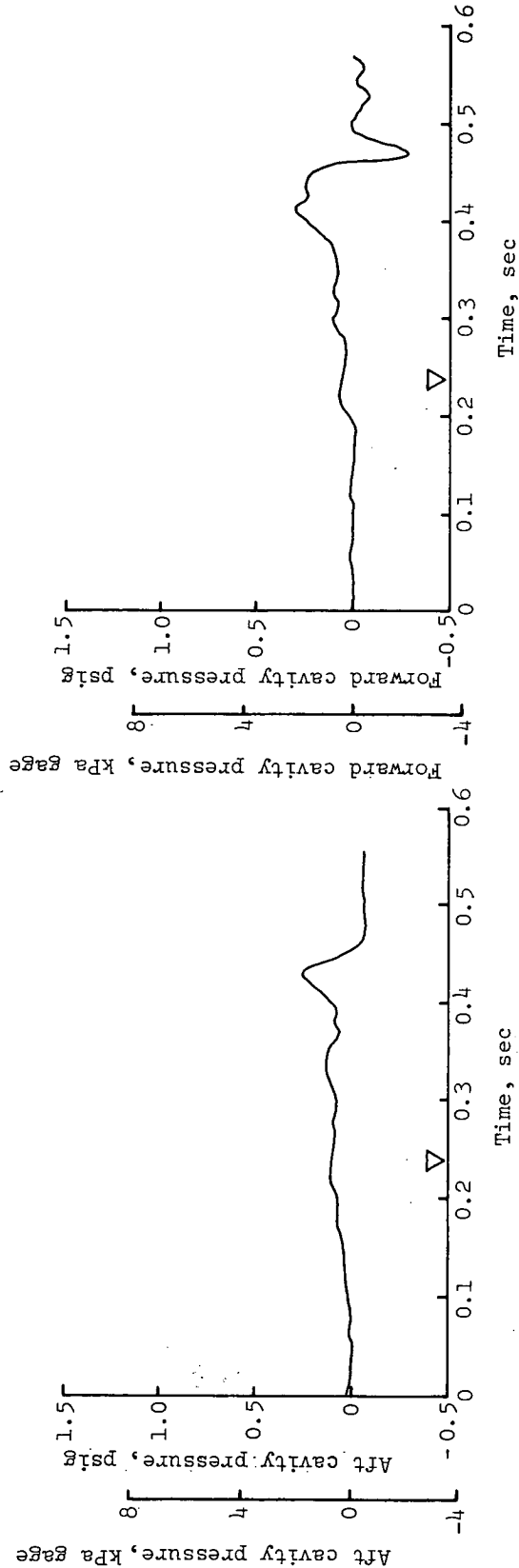
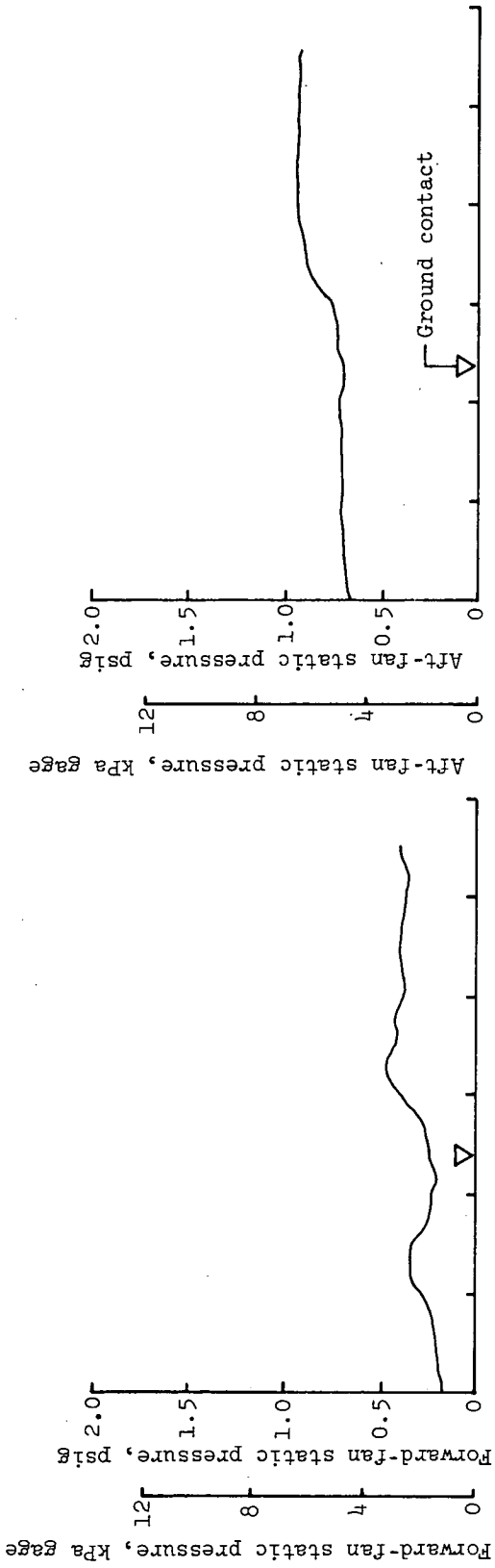

(d) Model cavity and fan static pressures.

Figure 8.- Concluded.

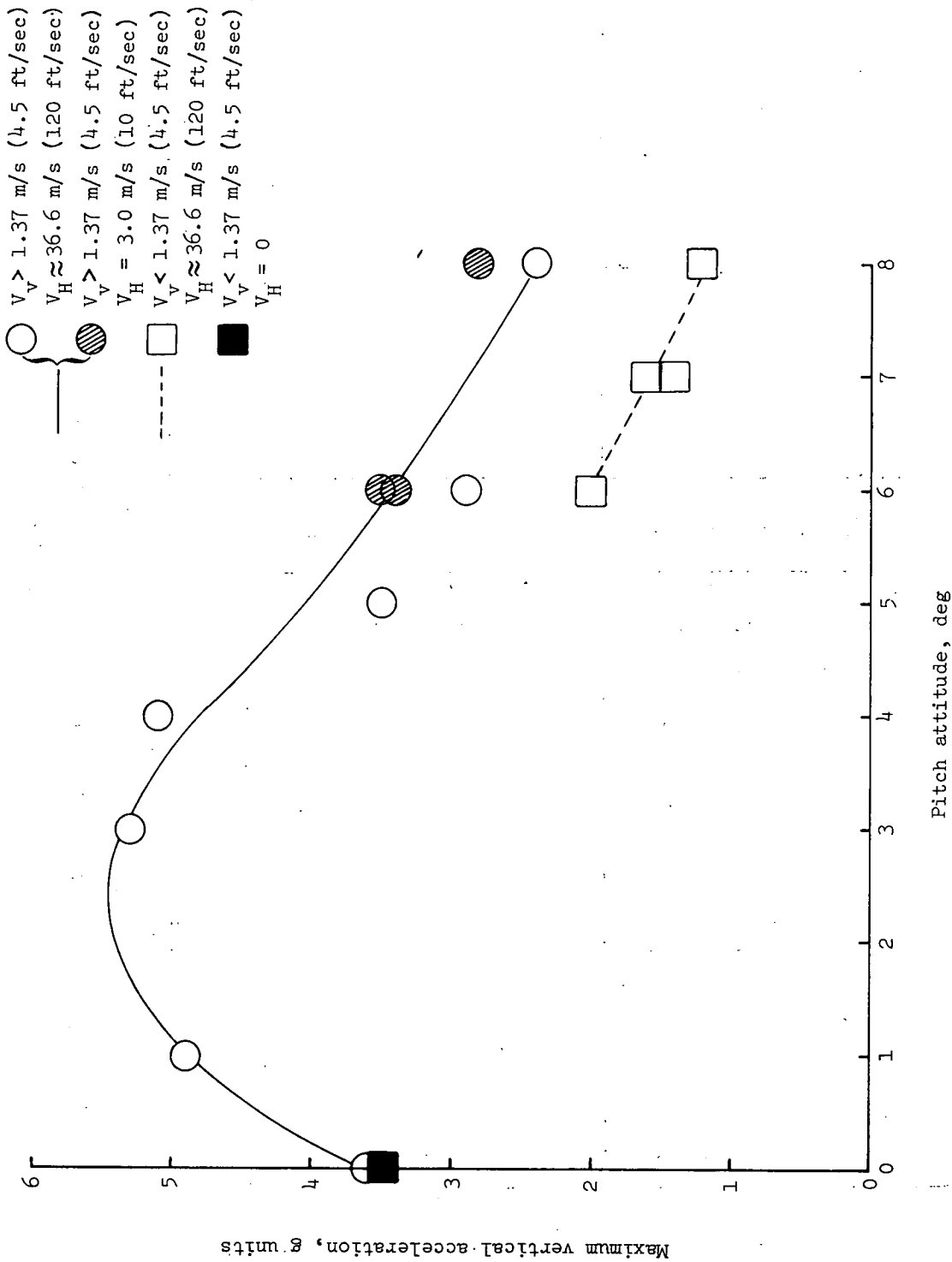

Figure 9.- Effect of body-pitch attitude on maximum vertical acceleration during landing impact of 0.3-scale Navy fighter model.

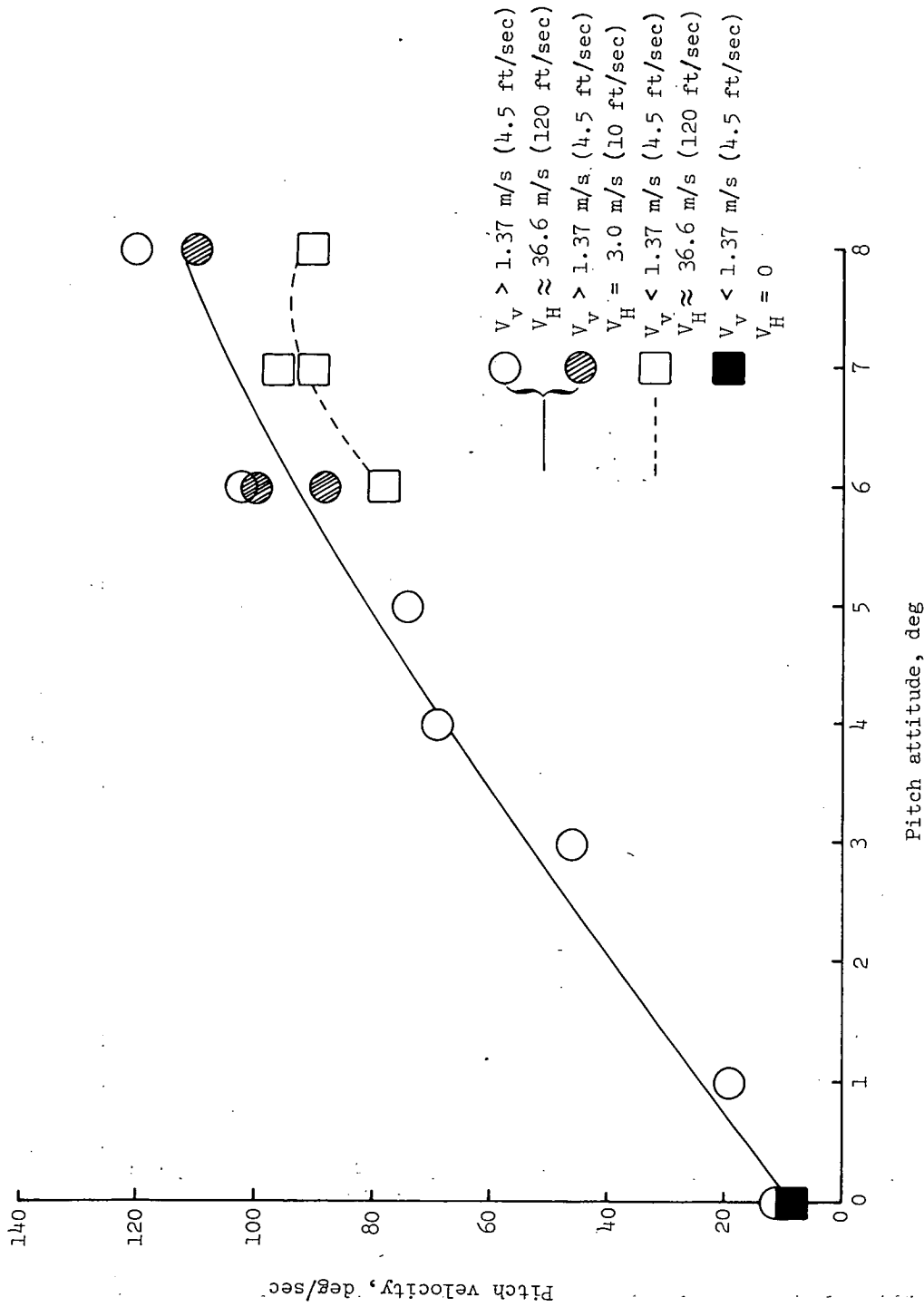

Figure 10.- Variation of pitch velocity with initial body-pitch attitude during landing impact of 0.3-scale Navy fighter model.

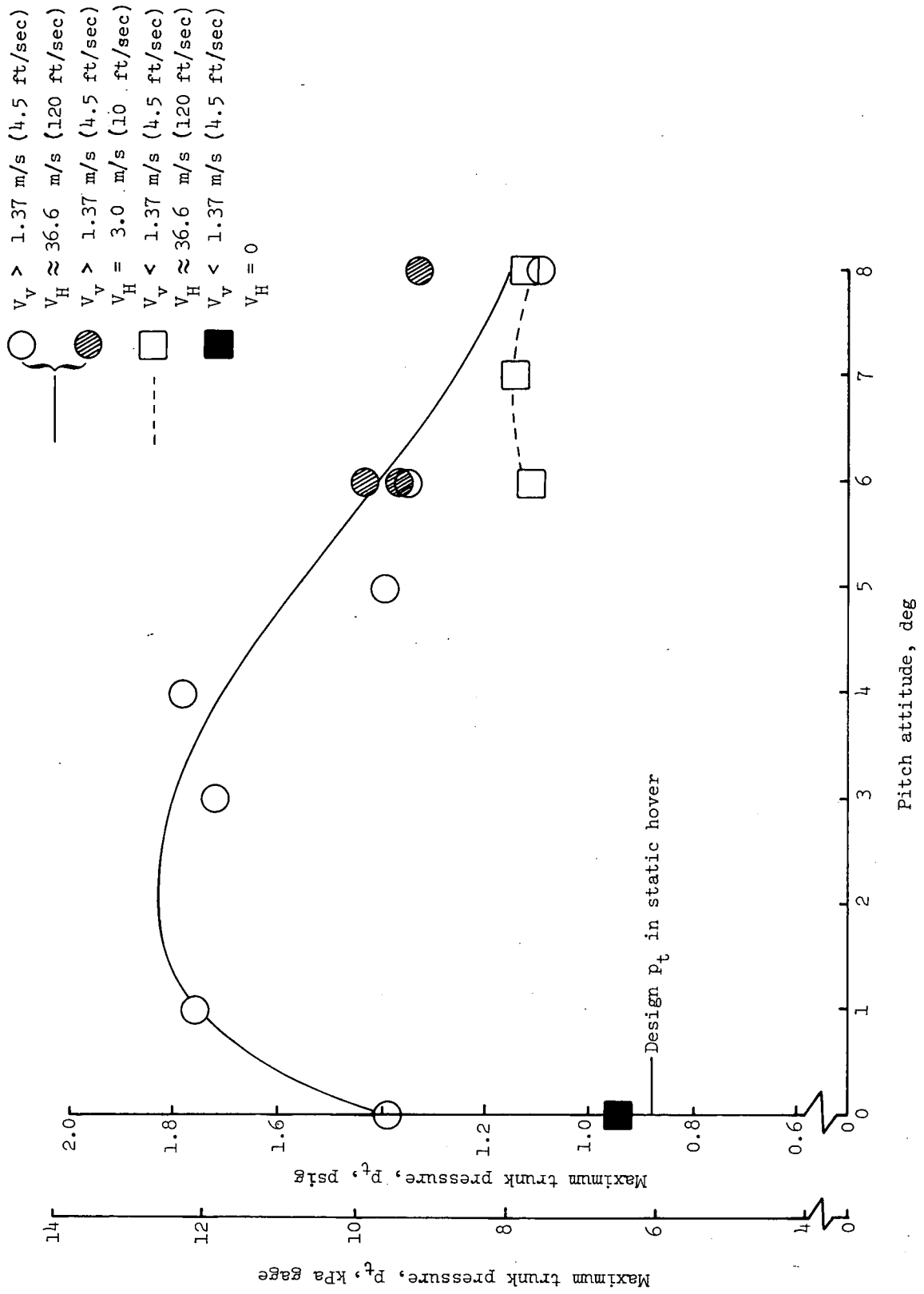

Figure 11.- Variation of maximum trunk pressure with initial body-pitch attitude during landing impact of 0.3-scale fighter model.

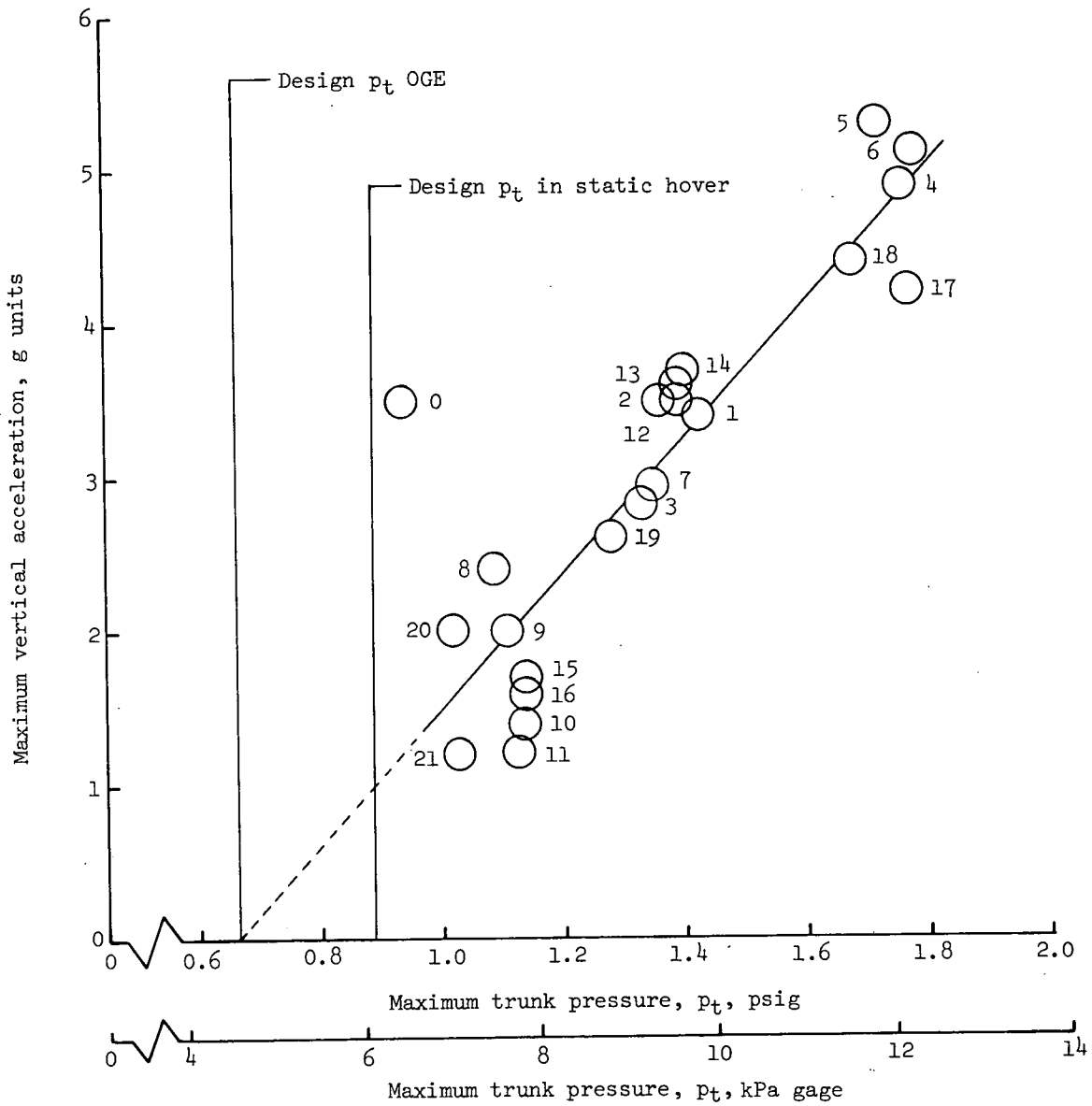

Figure 12.- Relationship of maximum vertical acceleration to maximum trunk pressure for all landing-impact tests with the 0.3-scale Navy fighter model. Run numbers are keyed to table III.

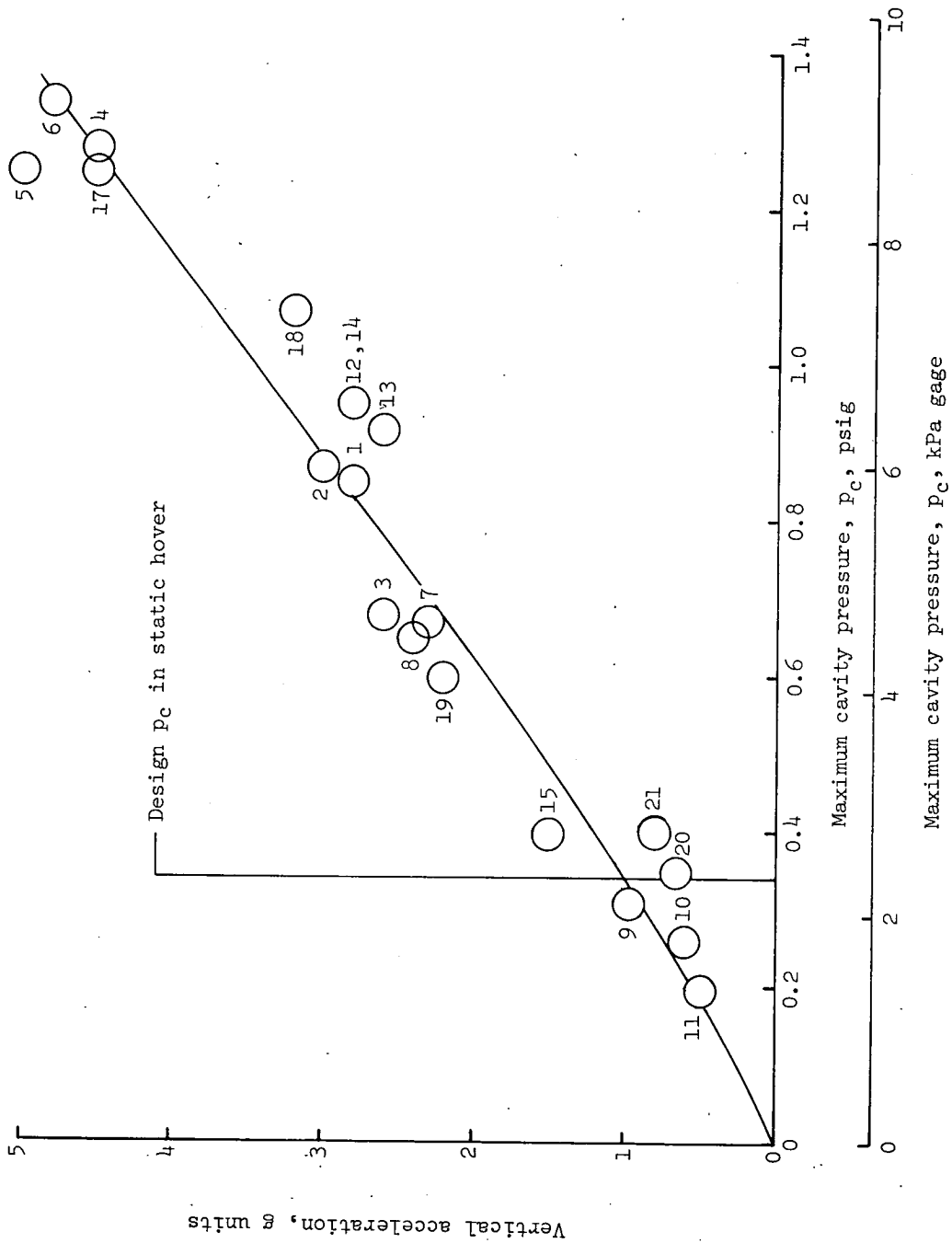
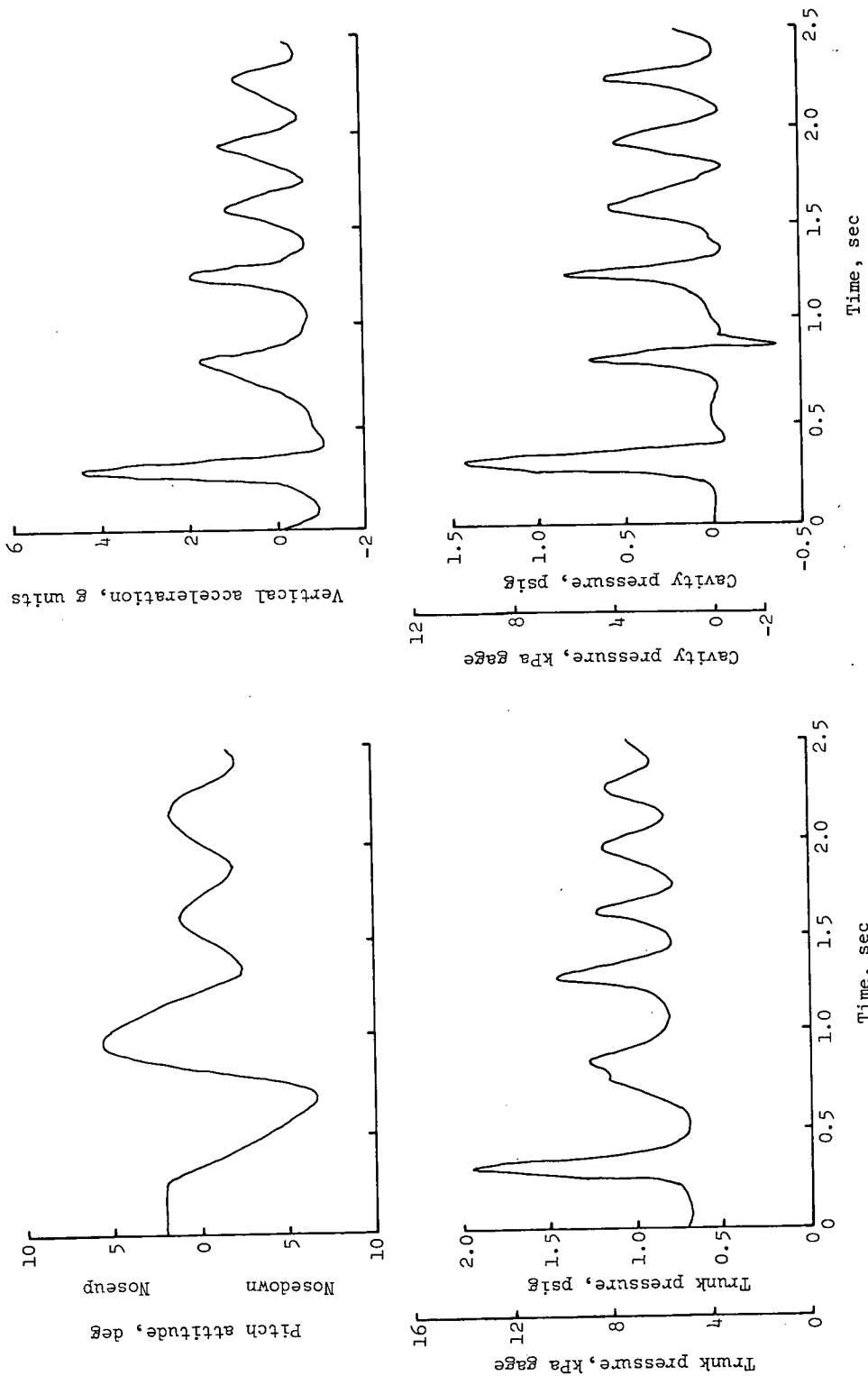
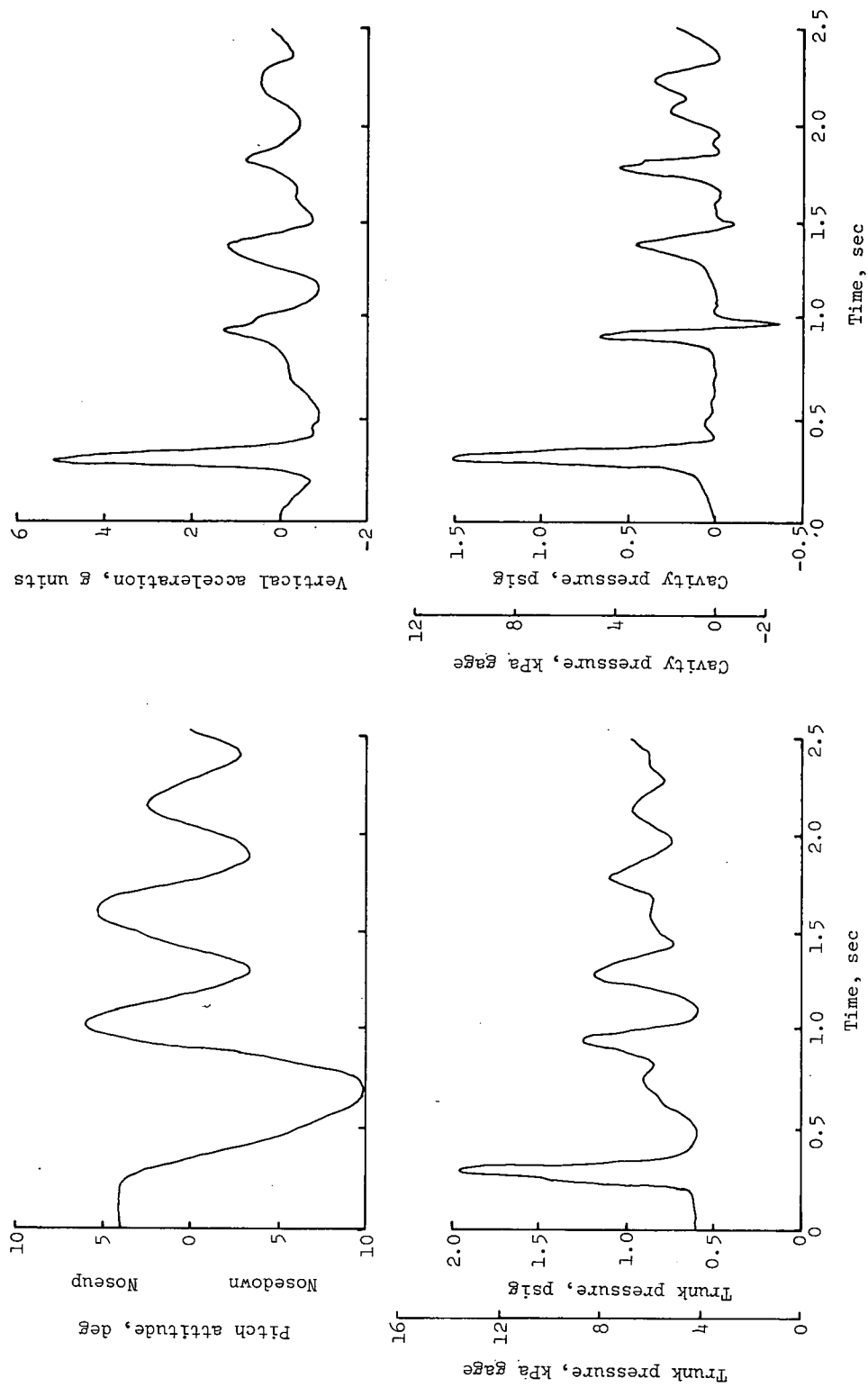

Figure 13.- Relationship of vertical acceleration at time of maximum cavity pressure to maximum cavity pressure when body attitude was approximately 0°. Run numbers are keyed to table III.



(a) Initial body-pitch attitude, 2°.

Figure 14.- Time history of pitch-stability study of 0.3-scale Navy fighter model.
 $V_H = 3.0$ m/s (10 ft/sec); wing lift, 0.



(b) Initial body-pitch attitude, 4°.

Figure 14.- Continued.

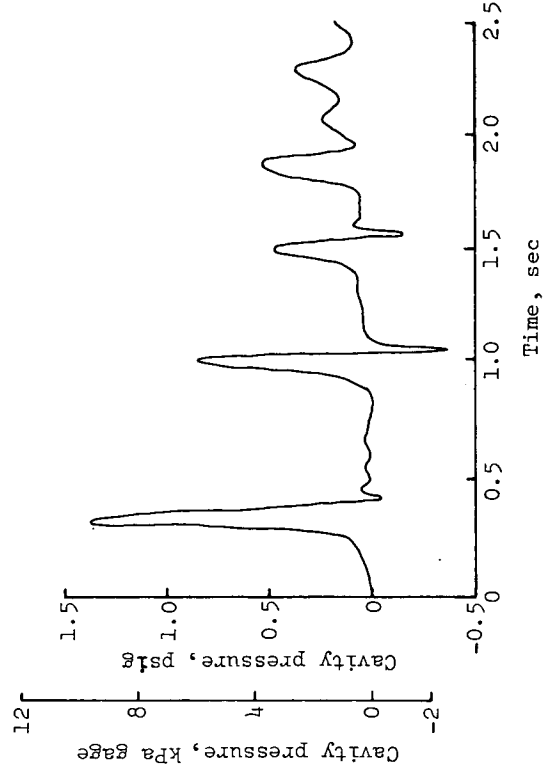
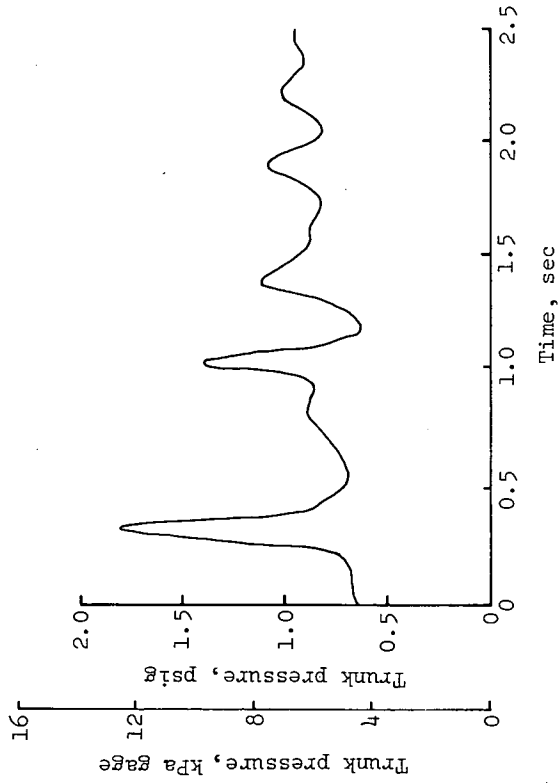
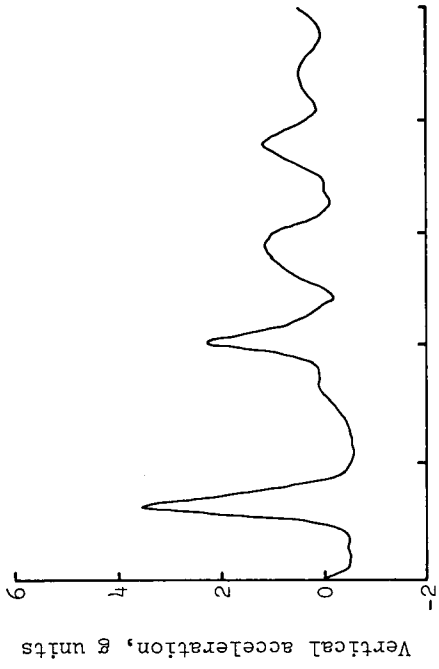
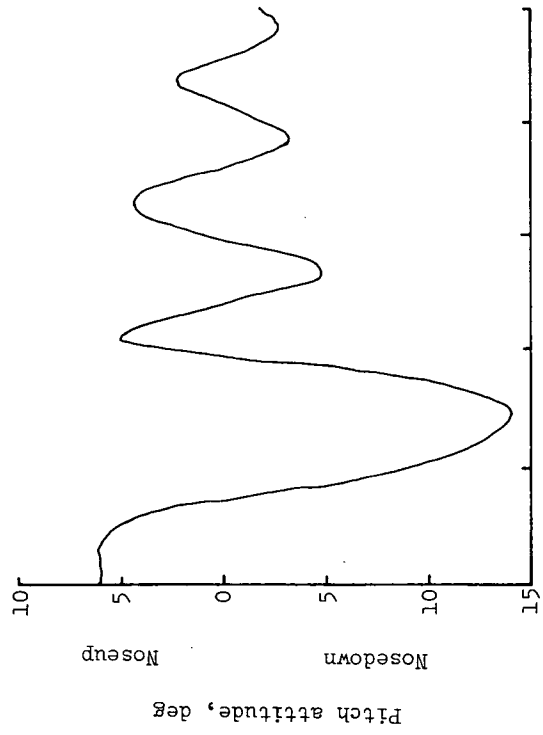

(c) Initial body-pitch attitude, 6°.

Figure 14.- Concluded.

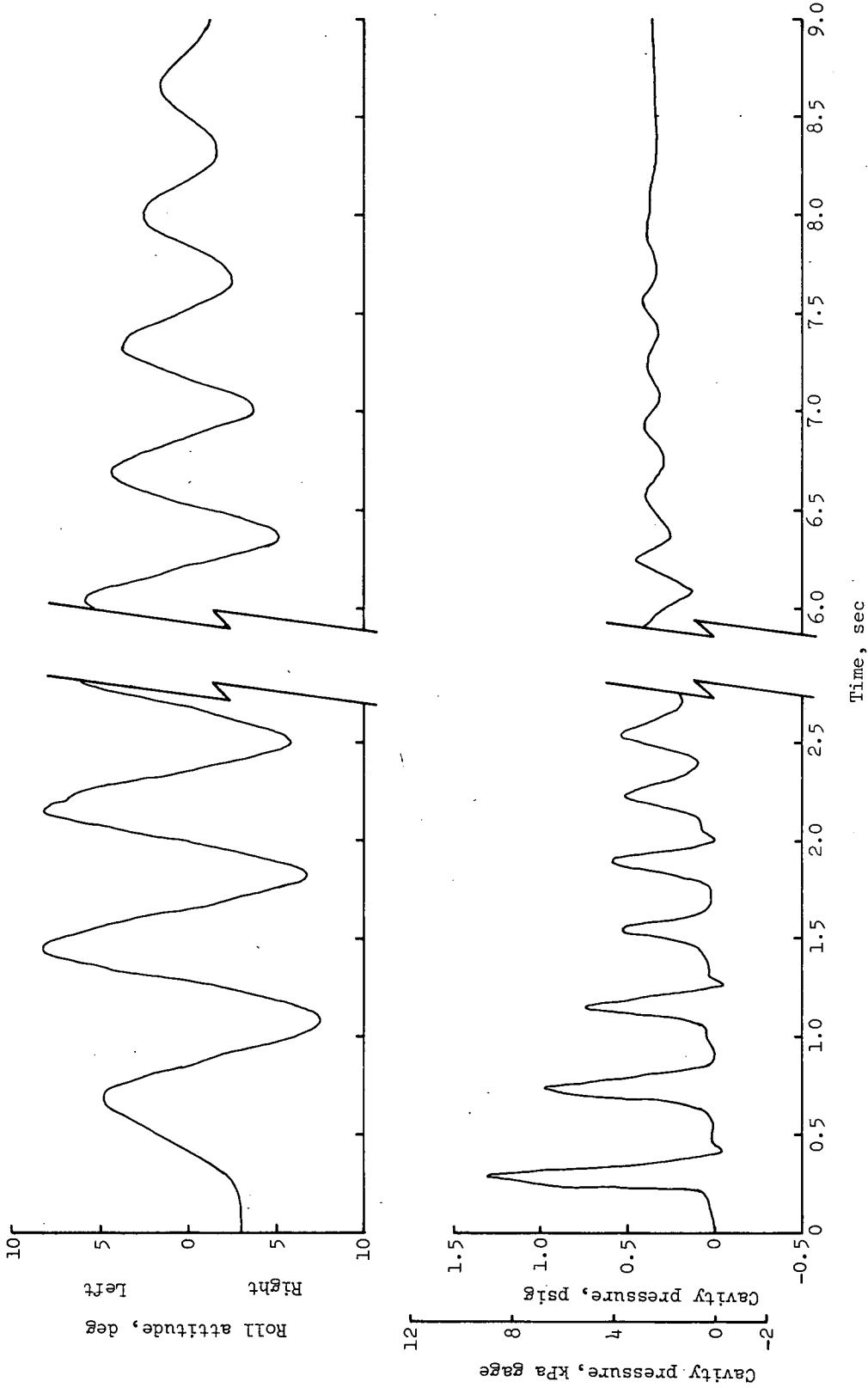

(a) Initial body-roll attitude, 30°.
 Figure 15.- Time history of roll-stability study of 0.3-scale Navy fighter model.
 V_H = 3.0 m/s (10 ft/sec); wing lift, 0.

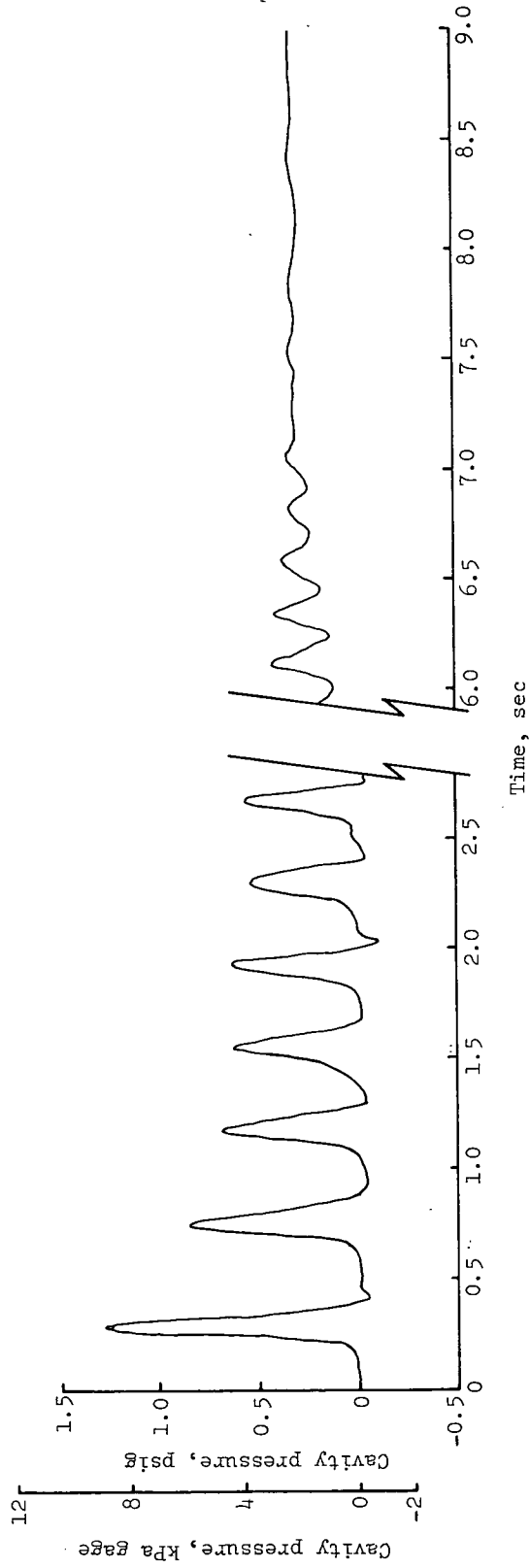
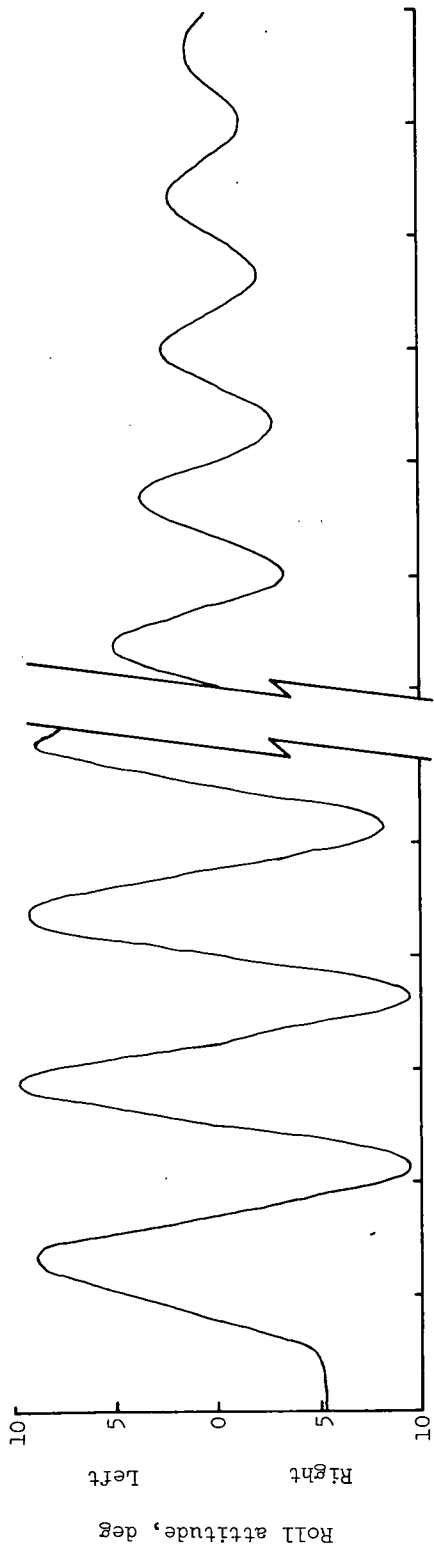

(b) Initial body-roll attitude, 5°.

Figure 15.- Concluded.

A motion-picture film supplement L-1168 is available on loan. Requests will be filled in the order received. You will be notified of the approximate date scheduled.

The film (16 mm, 8 min, color, silent) shows high-speed landing impact tests and low-speed stability tests of an air cushion landing system installed on a 0.3-scale dynamic model of a Navy fighter airplane. Landing impacts at several initial contact attitudes and sink rates are shown. Low-speed stability studies showing body motion following perturbations in pitch and in roll are also included in the film.

Requests for film supplement L-1168 should be addressed to:

NASA Langley Research Center
Att: Photographic Branch, Mail Stop 171
Hampton, Va. 23665

CUT

Date _____

Please send, on loan, copy of film supplement L-1168 to
TN D-7875.

Name of organization

Street number

City and State

Zip code _____

Attention: Mr. _____

Title _____



POSTMASTER : If Undeliverable (Section 158
Postal Manual) Do Not Return

"The aeronautical and space activities of the United States shall be conducted so as to contribute . . . to the expansion of human knowledge of phenomena in the atmosphere and space. The Administration shall provide for the widest practicable and appropriate dissemination of information concerning its activities and the results thereof."

—NATIONAL AERONAUTICS AND SPACE ACT OF 1958

NASA SCIENTIFIC AND TECHNICAL PUBLICATIONS

TECHNICAL REPORTS: Scientific and technical information considered important, complete, and a lasting contribution to existing knowledge.

TECHNICAL NOTES: Information less broad in scope but nevertheless of importance as a contribution to existing knowledge.

TECHNICAL MEMORANDUMS: Information receiving limited distribution because of preliminary data, security classification, or other reasons. Also includes conference proceedings with either limited or unlimited distribution.

CONTRACTOR REPORTS: Scientific and technical information generated under a NASA contract or grant and considered an important contribution to existing knowledge.

TECHNICAL TRANSLATIONS: Information published in a foreign language considered to merit NASA distribution in English.

SPECIAL PUBLICATIONS: Information derived from or of value to NASA activities. Publications include final reports of major projects, monographs, data compilations, handbooks, sourcebooks, and special bibliographies.

TECHNOLOGY UTILIZATION PUBLICATIONS: Information on technology used by NASA that may be of particular interest in commercial and other non-aerospace applications. Publications include Tech Briefs, Technology Utilization Reports and Technology Surveys.

Details on the availability of these publications may be obtained from:

SCIENTIFIC AND TECHNICAL INFORMATION OFFICE

NATIONAL AERONAUTICS AND SPACE ADMINISTRATION

Washington, D.C. 20546