

NASA TECHNICAL NOTE

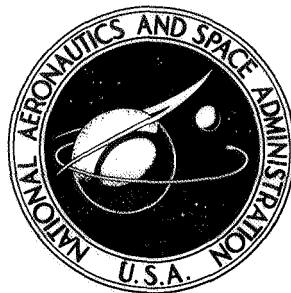

NASA TN D-7843

NASA TN D-7843

CASE FILE  
COPY

DESCRIPTION AND FLIGHT TEST RESULTS  
OF THE NASA F-8 DIGITAL  
FLY-BY-WIRE CONTROL SYSTEM

A collection of papers from the NASA Symposium  
on Advanced Control Technology,  
Los Angeles, Calif., July 9-11, 1974

*Flight Research Center*  
*Edwards, Calif. 93523*



NATIONAL AERONAUTICS AND SPACE ADMINISTRATION • WASHINGTON, D. C. • FEBRUARY 1975

1. Report No. NASA TN D-7843		2. Government Accession No.		3. Recipient's Catalog No.	
4. Title and Subtitle DESCRIPTION AND FLIGHT TEST RESULTS OF THE NASA F-8 DIGITAL FLY-BY-WIRE CONTROL SYSTEM A collection of papers from the NASA Symposium on Advanced Control Technology, Los Angeles, Calif., July 9-11, 1974				5. Report Date February 1975	
				6. Performing Organization Code	
7. Author(s)				8. Performing Organization Report No. H-853	
				10. Work Unit No. 501-26-06	
9. Performing Organization Name and Address NASA Flight Research Center P.O. Box 273 Edwards, California 93523				11. Contract or Grant No.	
				13. Type of Report and Period Covered Technical Note	
12. Sponsoring Agency Name and Address National Aeronautics and Space Administration Washington, D. C. 20546				14. Sponsoring Agency Code	
15. Supplementary Notes A collection of papers from the NASA Symposium on Advanced Control Technology and Its Potential for Future Transport Aircraft, Los Angeles, Calif., July 9-11, 1974					
16. Abstract  A NASA program is being conducted to develop digital fly-by-wire (DFBW) technology for aircraft applications. Phase I of the program demonstrated the feasibility of using a digital fly-by-wire system for aircraft control through developing and flight testing a single channel system, which used Apollo hardware, in an F-8C airplane. The objective of Phase II of the program is to establish a technology base for designing practical DFBW systems. It will involve developing and flight testing a triplex digital fly-by-wire system using state-of-the-art airborne computers, system hardware, software, and redundancy concepts.  The papers included in this report describe the Phase I system and its development and present results from the flight program. Man-rated flight software and the effects of lightning on digital flight control systems are also discussed.					
17. Key Words (Suggested by Author(s)) Digital fly-by-wire systems, digital control systems design, man-rated software, lightning effects, redundancy, flight test				18. Distribution Statement Unclassified - Unlimited  Category: 02	
19. Security Classif. (of this report) Unclassified		20. Security Classif. (of this page) Unclassified		21. No. of Pages 198	22. Price* \$7.00

\*For sale by the National Technical Information Service, Springfield, Virginia 22151



## CONTENTS

1.	AN OVERVIEW OF NASA'S DIGITAL FLY-BY-WIRE TECHNOLOGY DEVELOPMENT PROGRAM . . . . .	1
	Calvin R. Jarvis, NASA Flight Research Center	
2.	DESIGN AND DEVELOPMENT EXPERIENCE WITH A DIGITAL FLY-BY-WIRE CONTROL SYSTEM IN AN F-8C AIRPLANE . . . . .	13
	Dwain A. Deets, NASA Flight Research Center	
3.	MECHANIZATION OF AND EXPERIENCE WITH A TRIPLEX FLY-BY-WIRE BACKUP CONTROL SYSTEM . . . . .	41
	Wilton P. Lock and William R. Petersen, NASA Flight Research Center, and Gaylon B. Whitman, Sperry Flight Systems Division	
4.	THE EFFECTS OF LIGHTNING ON DIGITAL FLIGHT CONTROL SYSTEMS . . . . .	73
	J. Anderson Plumer, General Electric Co., Wilbert A. Malloy, General Motors Corp., and James B. Craft, NASA Flight Research Center	
5.	MAN-RATED FLIGHT SOFTWARE FOR THE F-8 DFBW PROGRAM . . . . .	93
	Robert R. Bairnsfather, The Charles Stark Draper Laboratory, Inc.	
6.	FLIGHT TEST EXPERIENCE WITH THE F-8 DIGITAL FLY-BY-WIRE SYSTEM . . . . .	127
	Kenneth J. Szalai, NASA Flight Research Center	
7.	A PILOT'S OPINION OF THE F-8 DIGITAL FLY-BY-WIRE AIRPLANE . . . . .	181
	Gary E. Krier, NASA Flight Research Center	

1. AN OVERVIEW OF NASA'S DIGITAL FLY-BY-WIRE  
TECHNOLOGY DEVELOPMENT PROGRAM

Calvin R. Jarvis  
NASA Flight Research Center

SUMMARY

The feasibility of using digital fly-by-wire systems to control aircraft was demonstrated by developing and flight testing a single channel system, which used Apollo hardware, in an F-8C test airplane. This is the first airplane to fly with a digital fly-by-wire system as its primary means of control and with no mechanical reversion capability. The development and flight test of a triplex digital fly-by-wire system, which will serve as an experimental prototype for future operational digital fly-by-wire systems, is underway.

INTRODUCTION

The advantages of digital fly-by-wire (DFBW) systems in terms of control system flexibility and reliability were demonstrated for spacecraft applications in NASA's manned space program. However, the transfer of this technology from spacecraft to aircraft is not direct and will require the identification and solution of many problems.

DFBW technology, when fully utilized in the flight control system of an aircraft, can provide significant advantages over conventional control systems in terms of reduced costs, weight, and volume, and in improved performance. A redundant digital system, which can identify in-flight system failures and reconfigure itself, offers a potential reliability comparable to that of the basic aircraft structure as well as the advantages of automatic control techniques.

Although these benefits cannot be easily quantified for all classes of aircraft, design studies do indicate major rewards in terms of more effective flight control systems and, thus, more effective aircraft. But even more important, these systems lay the ground work for active control technology, and it is the active-control-configured aircraft that offers the greatest potential in economic gains and performance advancements.

The overall objective of NASA's digital fly-by-wire program is to provide the foundation for this technology, in terms of design criteria and operational experience, which will lead to the development of practical digital fly-by-wire systems for future aircraft. To accomplish this objective, the program was separated into two phases, with an F-8C airplane (fig. 1) used as the test vehicle.

The goal of Phase I, which has been accomplished, was to demonstrate the feasibility of using a DFBW system as the primary flight control system of an aircraft. To accomplish this goal, a single channel DFBW primary flight control system was flight tested, using an analog backup control system for fail/safe redundancy.

The goal of Phase II is to establish a design base for the development of practical DFBW systems. This will involve the development and flight test of a triplex DFBW system using redundancy management and data bus concepts.

Figure 2 shows the schedule for Phases I and II. The major aspects of each phase are discussed in the following sections.

### SINGLE CHANNEL SYSTEM DEVELOPMENT

To establish the feasibility of the DFBW concept, a system was designed to replace the basic mechanical primary flight control system of the F-8C test airplane in all three control axes. All mechanical connections linking the pilot's control stick and rudder pedals to the control surfaces were removed. To be compatible with fly-by-wire design philosophy and development practice, no mechanical reversion capability was provided even during the first part of the flight-test program. This is particularly significant because it required that satisfactory design and test techniques be demonstrated before the first flight. A single channel digital system concept was selected as the most straightforward approach to establishing system feasibility.

To minimize cost and development time, digital hardware and software originally developed for the Apollo program were used as the heart of the digital system. An Apollo guidance and navigation system was used which consisted of a digital guidance computer, an inertial measurement unit, and associated interface elements. Use of this hardware also made available highly trained Apollo support teams. Another factor leading to the selection of the Apollo computer was its demonstrated 70,000-hour mean-time-before-failure record. This factor overrode shortcomings of the hardware which resulted in some operational constraints.

A more complete description and discussion of the digital system is presented in paper 2. Pertinent aspects of man-rated software are covered in paper 4.

To provide redundancy if the primary digital system failed, an analog flight control system from a lifting body research vehicle was modified extensively and installed in the F-8C airplane as a triplex analog backup control system (paper 3).

Phase I began in January 1971. During the following 15 months, five major contractors took part in the development and flight qualification of the Phase I system. These contractors and their areas of responsibility were:

Delco Electronics . . . . .	. Digital system hardware
The Charles Stark Draper Laboratory, Inc. (MIT) . . . . .	. Digital system software
Sperry Flight Systems Division . . . . .	. Analog backup control system
Hydraulic Research and Manufacturing Company . . . . .	. Secondary actuators
Ling-Temco-Vought, Inc. . . . .	. Aircraft and electrical systems

In addition to control law design and contractor coordination, NASA was responsible for specifying the Phase I system baseline configuration and interface requirements, verifying the final software and hardware flight readiness, and conducting the flight tests.

The Phase I system was first used in flight on May 25, 1972. This was the first flight of an aircraft in which a digital fly-by-wire flight control system was the primary means of control. As noted previously, no mechanical reversion capability was provided. Confidence in the reliability of the digital system was demonstrated by using it on the first takeoff and landing.

Forty-two flights were made before the flight program was completed in November 1973. The total flight time was 58 hours. The pilot controlled the airplane most of this time using the primary digital system. Approximately 14 hours were flown using the analog backup system for evaluation purposes, inasmuch as no digital system failures were experienced during flight. The flight-test results are presented in papers 3 and 6.

Phase I established the feasibility of DFBW systems for primary aircraft control and provided flight data related to control law design, software verification, and operational procedures for DFBW systems.

#### MULTICHANNEL SYSTEM DEVELOPMENT

The goal of Phase II is to establish a design base for the development and implementation of future practical DFBW systems. To accomplish this goal a multi-channel system is being developed which will provide redundancy management flight-test experience and verify other concepts of particular concern to the space shuttle orbiter development.

The Phase II system configuration and major tasks are discussed in the following sections.

## System Configuration

A simplified diagram of the fully redundant triplex DFBW system is shown in figure 3. The principal elements of the system are to be installed on a removable pallet assembly, as the single channel system was in Phase I. Major components developed for Phase I, such as the analog backup control system, redundant secondary actuators, electrical power system, and instrumentation system, are to be retained for use during Phase II.

Dedicated, redundant sensors will be used to measure airplane angular rate, attitude, acceleration, and air data. Sensor inputs will be cross-strapped to each computer and synchronized on a bit-by-bit basis. Surface command outputs will be voted for fault detection and supplied to the triplex, force-summed, secondary actuator servo valves. Differential pressure equalization will be used to minimize nonlinear secondary actuator effects. A two channel (active and monitor) analog backup control system will be provided for use if the primary system fails.

The system will be designed to minimize ground operational and preflight support requirements. All system status testing will be automated and will be done onboard the airplane.

The digital processor selected for Phase II is a state-of-the-art, off-the-shelf, general-purpose computer with floating-point and microprogramming features. The computer is an order of magnitude faster than the Apollo computer used in Phase I. The main storage memory is fully programable, which provides greater software flexibility. This increase in computer capability is of particular importance in carrying out the objectives of the Phase II program.

## Evaluation of Space Shuttle Orbiter DFBW Concepts

An important aspect of Phase II is coordination with the shuttle orbiter flight control system development. In addition to being the first application of DFBW in an aerodynamic vehicle, the orbiter will contribute significantly to digital system technology by addressing the problems of redundancy management (reliability) and overall mechanization.

The shuttle flight control system will use the same digital processors as those being used in Phase II of the F-8 DFBW program. The Phase II triplex processor/sensor configuration will thus make it possible to evaluate certain aspects of the shuttle system by using the F-8C airplane as a test-bed.

*Redundancy management.* — The redundancy management concept developed for the orbiter system to detect and isolate digital processor and control system sensor failures will be implemented and flight tested during Phase II. Because a reliable means of achieving failure detection and isolation is a major problem in the design of redundant DFBW systems, flight-test verification of the concepts in Phase II will establish a significant data base for future applications.

*Data bus.* — The data bus concept of reducing cabling and connector requirements for redundant systems by compressing data from several sensors onto



redundant transmission lines is important in the development of DFBW technology. The discrete format of signals in DFBW systems makes the data bus a natural solution to the complex cabling problem. In Phase II the technique proposed for the shuttle system will be used to process trim commands and mode panel information (e.g., status lights, mode change commands) and to transmit the information from the airplane cockpit to the palletized system in the equipment bay. This will greatly reduce the number of wires and will verify data bus utility for shuttle as well as future system applications.

*Computer synchronization.* — Of major concern in the design of any redundant DFBW system is whether or not to synchronize the computer operations and, if so, the best way to do it. The Phase II system will be designed with enough flexibility to permit the use of various synchronization approaches as well as asynchronous operation. Included will be the baseline approach selected for the orbiter system.

*Control laws.* — The first control laws to be evaluated in flight during Phase II will be similar to those developed for the F-8C airplane during Phase I and similar in format to those being developed for the shuttle orbiter. These include C\* and rate command modes for pitch and roll as well as direct control modes for each axis. Control law software required for moding and initialization will therefore be similar for both programs, which will permit some system verification.

*Higher order programming language.* — A higher order programming language, called Higher Aerospace Language (HAL), is being developed in support of shuttle software requirements. Use of this language in developing certain elements of the control laws for the Phase II system will make it possible to debug and verify it before it is actually applied to the shuttle orbiter.

*Backup control system.* — The present shuttle system configuration will require a dissimilar single channel digital backup control system during initial horizontal flight tests to override possible primary system generic failures. The executive structure for the shuttle backup system will be implemented in the Phase II system and flight-qualified through flight-test verification.

### Advanced Control Law Development

To assess the capability of a digital system to perform the functions necessary for future active control applications, additional control laws will be programmed and evaluated during Phase II. A specific task is the investigation of improvements that can be made in aircraft control law implementation as a result of the rapidly advancing digital fly-by-wire system capability. The availability of a powerful onboard digital computer system that can process sophisticated flight control laws in real time has added a new dimension to realizable control law development. Control laws previously too complex and unwieldy for analog system applications can now be considered prime candidates for digital applications.

Initial Phase II control law research is directed toward the use of active control for maneuver load control, possible improvement in ride quality, suppression of turbulence effects, flight envelope limiting techniques, and operation at reduced

static-stability margins. The basic elements of such a control law now being developed for the longitudinal axis are illustrated in figure 4. The structure consists of a boundary controller for angle-of-attack limiting, a normal controller for longitudinal commands, a direct-lift controller for commanding symmetric ailerons, a load controller, and autopilot modes. A proportional flap-to-elevator crossfeed is planned to compensate for the pitching moment produced by symmetric aileron deflection.

The design objective for the longitudinal axis is to achieve good handling qualities by matching desired response criteria for both positive and negative static stability margins. Gust load alleviation is provided by additional damping of short-period dynamics using the elevator surface. Angle-of-attack limiting is provided throughout the flight envelope.

Direct lift of the symmetric ailerons is combined with the elevator to minimize drag during maneuvers and to enhance gust load alleviation during cruise. The three autopilot modes are the conventional attitude hold, altitude hold, and Mach hold.

Other advanced control law prospects, in which adaptive techniques and optimal control theory are used, are being studied for possible flight-test evaluation during Phase II.

#### Remotely Augmented Vehicle Facility

As part of Phase II, a unique remotely augmented vehicle facility is to be developed to support advanced control law research and flight-test evaluation. A diagram of the proposed facility is shown in figure 5. During a test flight, a special remotely augmented vehicle test mode may be selected by the pilot that will divert his control commands to a ground computer facility, via a telemetry down-link, on which a particular advanced control law to be evaluated is programed. Control surface commands are determined by the ground computer on the basis of the pilot's airborne commands, the airplane's response, and the programed control law. The surface commands are then transmitted, via a telemetry up-link, to the airplane system and the corresponding control surface. The pilot flies the airplane through the control laws programed on the remotely located ground computer. Fail safety will be maintained through the use of reasonability tests built into the ground computer facility and safety networks in the telemetry equipment. This approach will permit a great deal of flexibility for control law evaluation without compromising the basic airborne system verification requirements.

#### CONCLUDING REMARKS

The full realization of the benefits of active control technology and the benefits predicted by its application to aircraft design depends on the development of practical, reliable, and versatile digital fly-by-wire (DFBW) control systems. The feasibility of such systems and confidence in their reliability and integrity were

established in Phase I of the F-8 DFBW program. The goal of Phase II of the program is to establish a design base from which practical, reliable systems can be developed. This will be accomplished by developing and flight testing a fully redundant triplex DFBW system.

The multichannel system development carried out during Phase II will establish techniques for validating redundant system software and hardware interfaces and for establishing operating procedures unique to DFBW systems. Flight-test evaluation of orbiter control system concepts using the F-8C airplane will result in verification of redundancy management software for digital processor and sensor fault detection and reduced generic failure probabilities for the orbiter system.

Flight-test evaluation of advanced control laws during Phase II will provide an opportunity to assess the capability of DFBW systems to perform the complex control tasks associated with active control applications.

The NASA DFBW program, although complementary to other fly-by-wire activities, is aimed specifically at providing the technology for practical digital flight controls for civil aircraft. As such, it represents the first step toward a new generation of active-control-configured aircraft which will offer significant economic advantages.

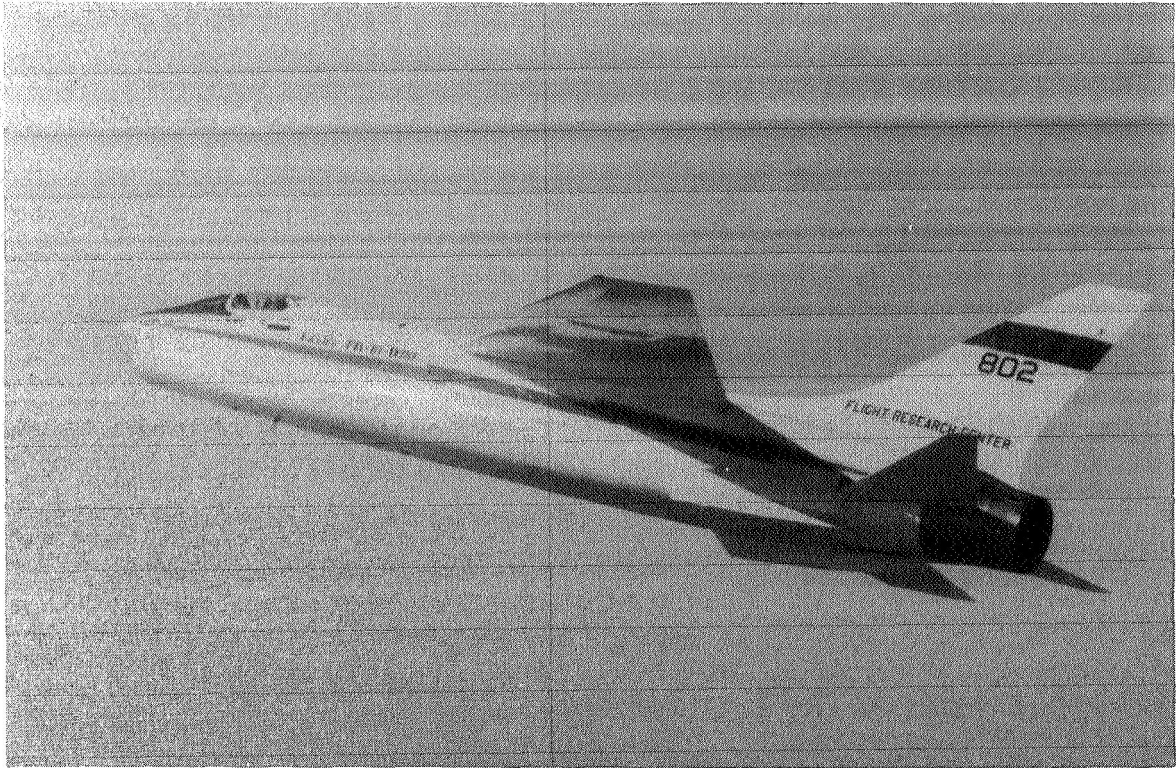

Figure 1. F-8C test airplane.

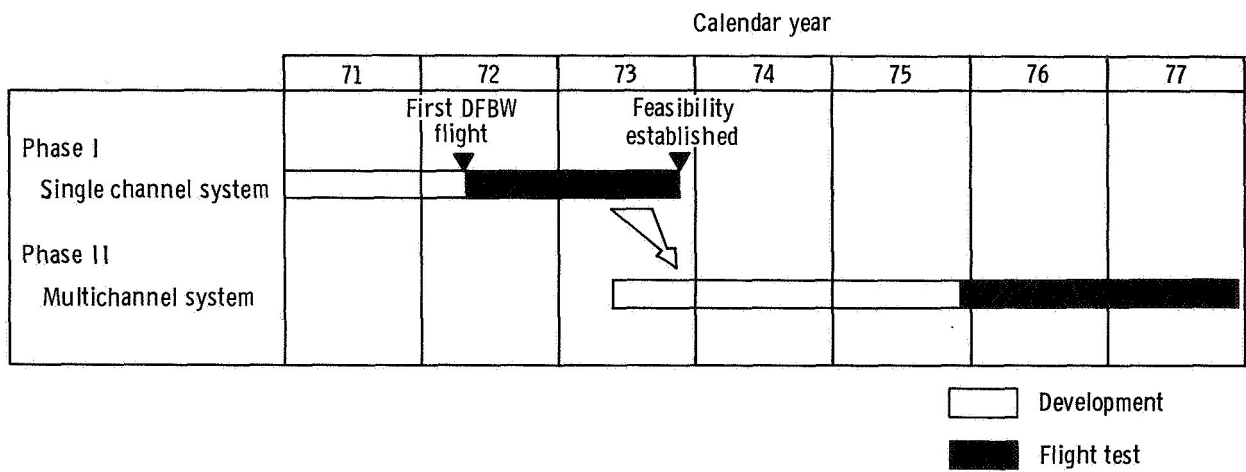

Figure 2. F-8 DFBW program schedule.

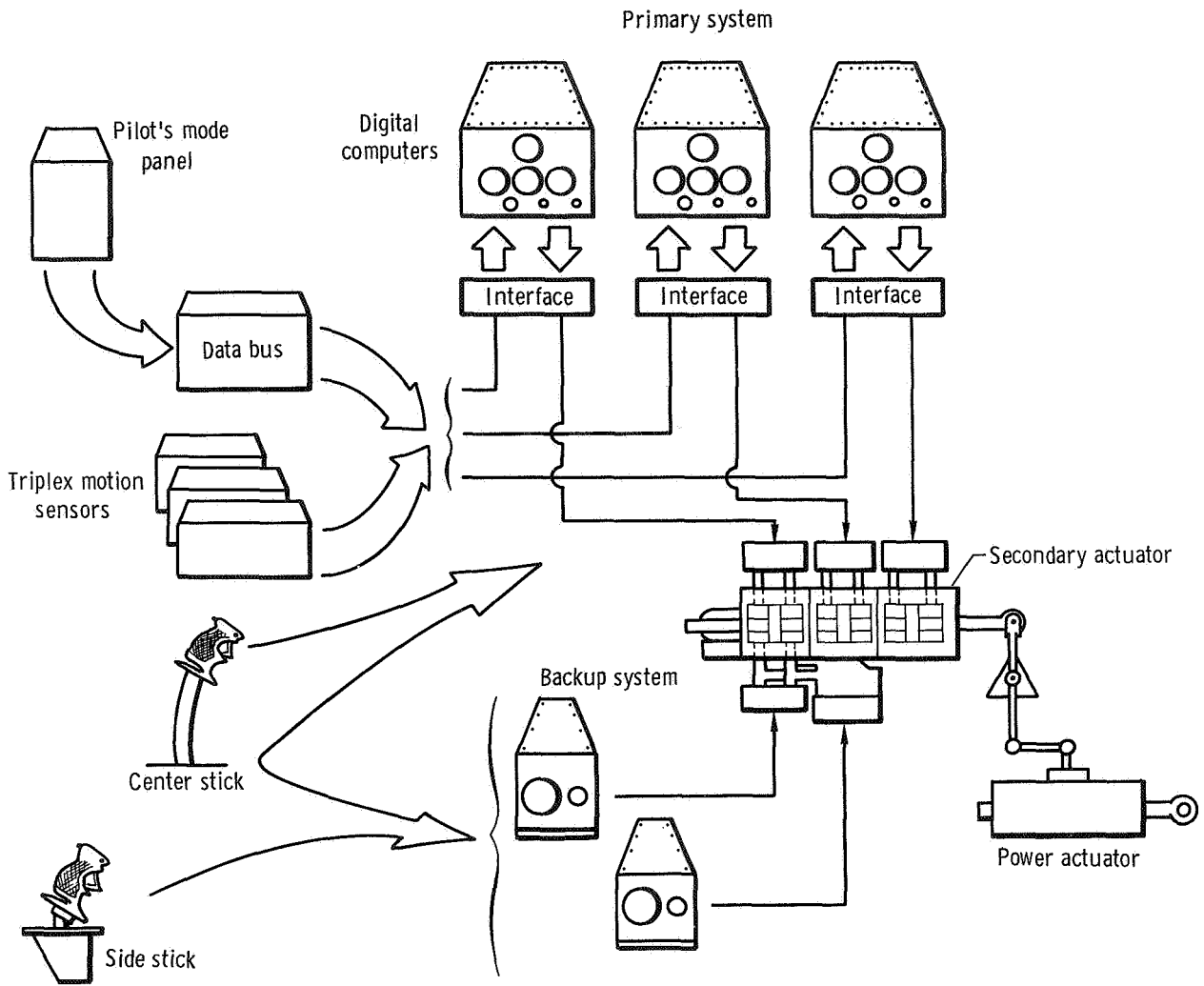

Figure 3. Phase II system configuration.

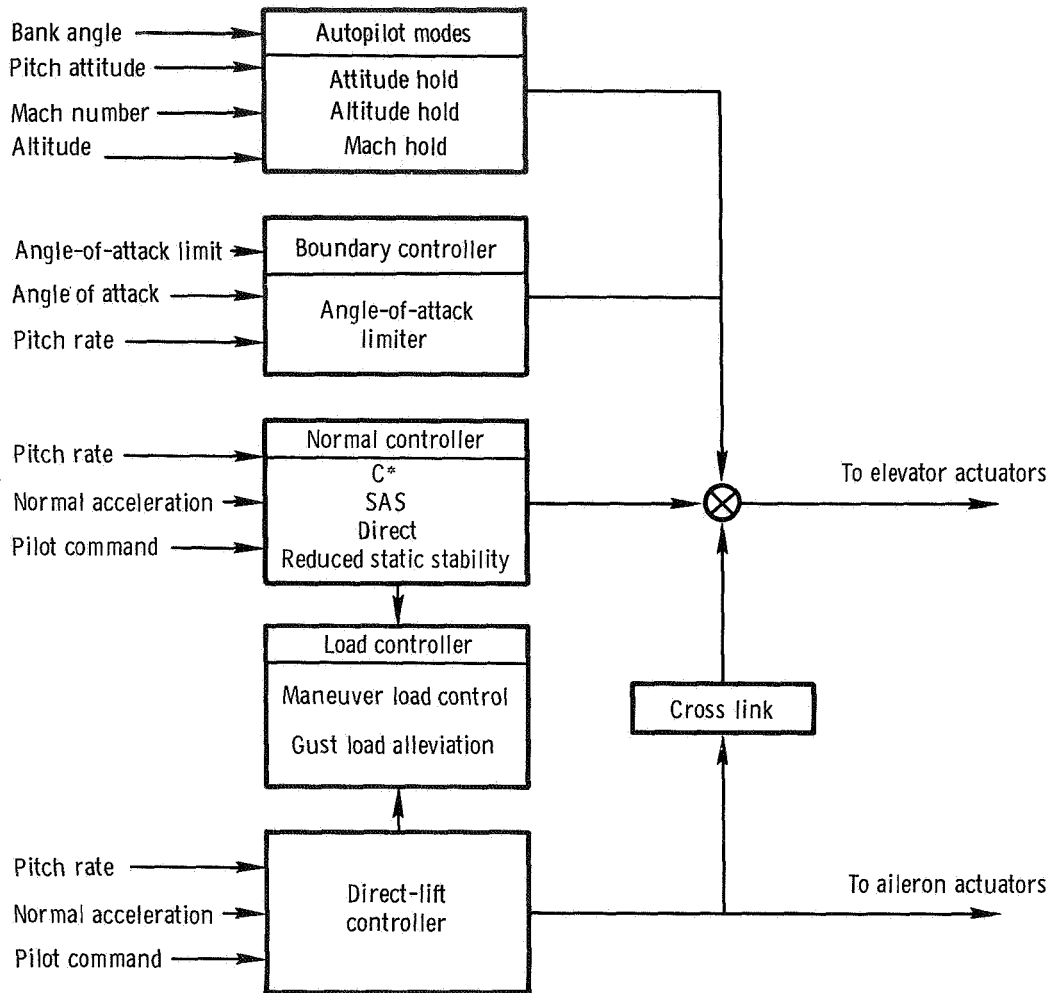

Figure 4. Active control law diagram for longitudinal axis.

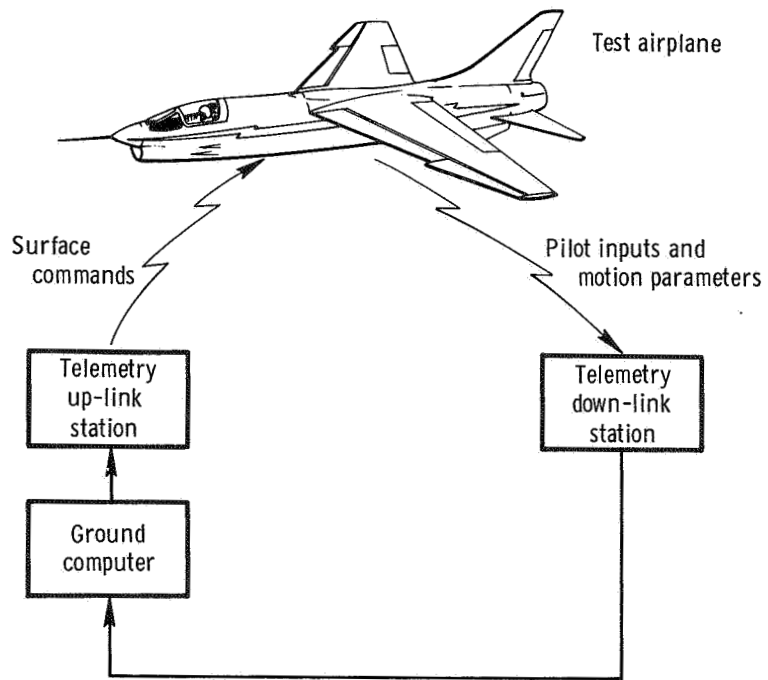

Figure 5. Remotely augmented vehicle facility.





2. DESIGN AND DEVELOPMENT EXPERIENCE  
WITH A DIGITAL FLY-BY-WIRE CONTROL SYSTEM  
IN AN F-8C AIRPLANE

Dwain A. Deets  
NASA Flight Research Center

SUMMARY

To assess the feasibility of a digital fly-by-wire system, the mechanical flight control system of an F-8C airplane was replaced with a digital primary system and an analog backup system. The Apollo computer was used as the heart of the primary system. This paper discusses the experience gained during the design and development of the system and relates it to active control systems that are anticipated for future civil transport applications.

INTRODUCTION

A major deterrent to the application of active controls to transport aircraft has been a lack of experience in designing highly reliable flight control augmentation systems and verifying them in flight. Digital fly-by-wire technology has the potential for providing the necessary reliability while still offering design flexibility. To assess the feasibility of a digital fly-by-wire system, the NASA Flight Research Center conducted a flight research program in which the mechanical flight control system of an F-8C airplane was replaced with a digital primary system and an electrical analog backup system.

This paper describes the fly-by-wire system and the design and development of the digital primary system. The system and the design procedures are assessed in light of similar applications being contemplated for future transport aircraft.

The paper was written in conjunction with papers 3, 5, 6, and 7 which discuss the backup control system, software management, and results from the flight tests.

## SYMBOLS

K	proportionality constant
KAZ	normal acceleration feedback gain to stabilizer, deg/g
KG	stick or rudder pedal gearing constant, deg/m
KP	roll rate feedback gain to ailerons, deg/deg/sec
KQ	pitch rate feedback gain to stabilizer, deg/deg/sec
KR	yaw rate feedback gain to rudder, deg/deg/sec
$q_k$	pitch rate at $k^{\text{th}}$ sample, deg/sec
s	Laplace transform variable
T	sample period, sec
z	complex variable, $e^{sT}$
$\theta_k$	pitch angle at $k^{\text{th}}$ sample

## TEST AIRPLANE

An F-8C airplane (fig. 1) was selected for use in flight testing a digital fly-by-wire system. Several characteristics of the airplane made it suitable for this test program. The handling qualities without control augmentation were acceptable for emergency operation, thus backup control could be provided through a relatively simple system. In addition, the airplane had enough space for the system's components, and the capacity of the hydraulic systems was adequate.

Some features of the F-8C airframe had an impact on the fly-by-wire system design. The variable-incidence wing moves up  $8^\circ$  for low-speed flight. This rotates the fuselage nose down relative to the free airstream, improving the pilot's visibility during the approach. Several functions within the flight control system are programed as a function of wing position. For example, the horizontal stabilizer is driven  $5^\circ$  leading edge up when the wing is raised.

The F-8C airplane does not have independent flap surfaces, so the ailerons are driven collectively to serve as flaps through a mechanical linkage independent of the primary control system. For this program the linkage was disconnected and the ailerons were driven to the drooped flap position through the fly-by-wire system.

The original F-8C flight control system had a direct linkage in pitch (no augmentation), and roll and yaw stability augmentation systems (SAS) (figs. 2(a) and 2(b)). The yaw SAS included an aileron-to-rudder interconnect with a gain programed as a function of stabilizer position.

### DATA ACQUISITION SYSTEM

A standard NASA pulse code modulation (PCM) system was installed to record airplane motion, pilot input, and fly-by-wire system parameters external to the computer. Seventy-seven channels of 9-bit data were recorded on an onboard tape and telemetered to a ground station for real-time monitoring. Eight of the channels were digital words indicating the state of 57 discrete values from the fly-by-wire system. Although excellent for automated data reduction, the PCM system proved to be unsuitable for investigating the effects of analog-to-digital and digital-to-analog quantization. The resolution of the PCM system was on the same order as that of the digital control system quantization, which made it difficult to isolate the effects of the control system quantization.

Internal digital computer parameters were recorded on the onboard PCM tape recorder. One-hundred-word pairs were strobed out every 2 seconds and recorded for postflight analysis. The word lists were resident in the software onboard the airplane and could be reprogramed during the flight tests. This recording system was used primarily to determine the gross status of the computed parameters within the flight control system; the strobe rate was inadequate for tracing individual parameters each control computational cycle.

### IRON BIRD SIMULATOR

An iron bird simulator played an important role in the development of the fly-by-wire system. The simulator consisted of another F-8C airplane, in which all the digital fly-by-wire flight control hardware was installed, tied in with a hybrid computer and appropriate interface equipment (fig. 3). The digital fly-by-wire hardware was flight qualified and served as spares for the flight vehicle. The F-8C aerodynamics and bending modes were modeled by using the digital portion of the hybrid computer for the aerodynamics and the analog portion for the bending modes.

### FLY-BY-WIRE SYSTEM

The fly-by-wire system had a digital primary control system and an electrical analog backup control system. Components of the fly-by-wire system are shown in figure 4, and the location of the components in the F-8C airplane is illustrated in figure 5.

A simplex digital primary system and a triplex electrical analog backup system

provided enough reliability that the mechanical system could be completely removed. The digital primary system consisted of a computer, inertial measurement unit, coupling data unit, and display and keyboard, all taken from the Apollo guidance and navigation system. Reference 1 provides details on this equipment relative to the Apollo application. The triplex backup control system consisted of only surface position command electronics. Specially designed electrohydraulic secondary actuators interfaced the primary and backup electronic commands with the conventional F-8C control surface power actuators.

Components of the fly-by-wire system were part of the primary or backup system and, in some instances, were shared between the two systems. Individual components are described in the following sections according to function.

### Computational

The Apollo computer performed all flight control computations in the primary control system. Characteristics of this computer are summarized in the following tabulation:

Read-only memory . . . . .	36,864 words
Scratch pad memory . . . . .	2,048 words
Word length . . . . .	14 bits plus sign and parity
Number system . . . . .	Fixed point, ones complement
Memory cycle time . . . . .	11.7 microseconds
Computation time –	
Add . . . . .	23.4 microseconds
Multiply . . . . .	46.8 microseconds
Divide . . . . .	81.9 microseconds

Although slow by today's standards, the computer could perform all flight control functions within 30 milliseconds. Flight control laws for the F-8C airplane were programmed for the computer's hardwired memory and could not be changed after the memory was manufactured. However, flexibility was achieved by placing feedback gains, logic flags, digital filter coefficients, and other gain variables in the computer's scratch pad memory; 105 of these variables associated with the flight control system could be changed.

Control laws for the backup system were mechanized in triplex control electronic boxes, which can be considered to be special-purpose analog computers. Each electronic box contained 67 operational amplifiers. Requirements for high reliability in the flight environment dictated the use of ruggedized packaging and hardwired circuits. Consequently, flexibility for changing control laws was limited to gain and nonlinear constant changes; even these changes required replacement of hardwired resistors and diodes. Although the control system is considered to be an analog system, more than half of each electronic box containing individual channels of the analog electronics was devoted to logic elements, such as comparators between the redundant channels.

## Pilot Interface

*Vehicle control and trim inputs.*— The center stick was the primary means of control for both the primary and the backup systems. It was connected to the basic F-8C mechanical feel system. Disconnecting the mechanical links to the control surface caused undesirable looseness in the lateral stick, so a viscous damper was added. Stick position was sensed through two separate linear variable differential transformers (LVDT) in each axis. Each LVDT had triplex windings. Two of the windings from one LVDT in each axis were used by the primary system; the third winding was for instrumentation. The second LVDT provided triplex inputs to the backup control system.

A minimum displacement, two-axis side stick was used as an alternate controller input to the backup system. This side stick was not part of the original fly-by-wire system; it was used only as a means of evaluating a "force type" side stick controller in an actual aircraft environment (papers 3 and 7).

The rudder pedals provided inputs to both the primary and the backup systems. Similar to the center stick, they were connected to the F-8C mechanical feel system and used LVDT's for sensing rudder pedal position.

Trim commands for primary pitch and roll were made through a two-axis beeper switch on the center stick. Backup trim inputs in all three axes were made through separate spring-loaded toggle switches on the pilot's left-hand console. These toggle switches were also used to provide primary yaw trim and primary pitch and roll trim inputs if the center stick trim switch failed. When the side stick was being used, trimming was accomplished through a beeper switch on the side stick.

*Fly-by-wire functional control.*— Figure 6 shows the mode and power panel, which was the pilot's means of communicating with the primary system. The pilot was able to choose between several different control system modes simply by depressing the appropriate button. Additionally, he was able to change system gains according to the logic loaded in the software before the flight. Several primary system failure status lights were located across the top of the panel, and power switches and power status lights were located across the bottom. Individual axes could be transferred to backup through the backup control system (BCS) switches. The pilot could also transfer all axes to backup simultaneously by using a "paddle switch" on the center stick.

A servo engage panel on the left-hand console permitted the pilot to selectively engage or disengage each channel of each servo actuator. The panel provided control over both the backup and the primary systems. The status of the actuation system and the backup electronics was displayed on this panel.

## Motion Sensing and Interface

Another component from the Apollo guidance and navigation system was the inertial measurement unit. Although angular body rates and linear accelerations

were not measured directly in the Apollo application, the substitution of aircraft gyros and accelerometers for the fly-by-wire tests would have required a major system modification and would have sacrificed the integrity of the total Apollo system. An alternate approach was adopted: Body rates and linear accelerations were computed from the gimbal angles and the digital incremental velocity vector information the inertial measurement unit provided to the Apollo computer for use in the primary system.

A coupling data unit provided the interface between the inertial measurement unit and the Apollo computer in the Apollo guidance system and provided the same function for the primary system in the F-8C application. The angular resolution was  $0.011^\circ$ ; however, the rate resolution was of more importance and was nonlinear with gimbal angle rate. Body angular rate estimation was directly related to gimbal angle rate resolution. Gimbal rate resolution was  $\pm 0.183$  deg/sec for rates less than 4.4 deg/sec, and  $\pm 2.74$  deg/sec for rates between 4.4 deg/sec and 70 deg/sec. The error was manifested as a random noise band of 2.74 deg/sec peak to peak for rates greater than 4.4 deg/sec. Acceleration was sensed by using pulse integrating pendulous accelerometers. The quantization level for the normal acceleration signals was 0.2g.

The coupling data unit contained several digital-to-analog converter channels, which made it possible to send the necessary primary system commands to the control surfaces. To protect against undetected failures between the computer and the surface actuators, dual signals were generated in each axis, beginning with dualized commands to dual digital-to-analog converters in the coupling data unit in each axis. The control surface drive signals were quantized to  $\pm 384$  levels, which is somewhat less than a full 9-bit word.

### Control Surface Actuation

Similar actuation systems were used in each axis. Each actuation system had a secondary actuator and a power actuator. Separate sets of actuators were used for the left and right horizontal stabilizers and ailerons. A single set of actuators was used for the rudder.

The hydraulic power actuators from the basic F-8C airplane were used without modification. Electrohydraulic secondary actuators were installed to drive the metering valves of each of the five power actuators. The secondary actuators acted as three-chamber force summing devices when driven from the backup system. The primary system drove the secondary actuators through active monitor servo valves.

When the secondary actuators were driven through the primary system, they were stabilized through the active servo valve in the primary system electronics box. Analog 5-hertz low-pass filters were included in the primary system electronics. When driven through the backup servo valves, the secondary actuators were stabilized in the backup system electronics packages, one for each of the three backup channels.

Paper 3 describes the actuation systems in more detail.

### Primary/Backup System Interface

A functional diagram of the fly-by-wire system is shown in figure 7. The Apollo computer received inputs from the pilot's stick together with aircraft motion information from the inertial measurement unit. Surface commands were computed according to the programmed control laws.

The two drive signals for each surface represented commands to the secondary actuator position loop, which was closed with analog stabilization electronics outside the Apollo computer. As shown in figure 7, there was an active and a monitor servo path. If a failure occurred in either path, a hydraulic comparator would sense the differential pressure between the active and the monitor servo valve and transfer control to the backup control system. As long as the primary control system was operating normally, the backup control system would track the active channel by way of the synchronization network. Only the hydraulic pressure was bypassed at the secondary actuator, so that the backup system was ready to take over at any time. If a transfer to the backup system was requested, the bypass was removed and the synchronization network was disabled, resulting in immediate proportional control from the pilot's stick. In the backup mode, the active servo valve was blocked and the secondary actuator operated as a force summer for the three backup channels. The digital computer continued to operate, computing the control laws which gave the best estimate of what the backup system commanded. If a transfer to the primary control system was attempted, the transient was small as long as the computer was tracking the backup system. If the error was excessive between the primary control system and the backup control system, a cross-channel comparator prevented transfer to the primary control system.

### Fault Detection

Although built-in fault detection was extremely important for both the primary and the backup systems, it was of particular importance in the primary system. Because the primary system was full authority as well as single channel, its responses could have been hazardous if failures were not handled properly. Therefore, it had to be established that no digital computer system hardware failure could cause a hardover or otherwise hazardous signal. Figure 8 shows the type of digital system failure detection used. The Apollo computer had an extensive and proved fault detection and reporting system which was built into the computer hardware (item 1 in the figure). This system, modified slightly for application to the F-8C airplane, was the most significant portion of the failure detection system. Some of the types of failures detected were:

- Logic circuits –
  - Parity failed
  - Program entered loop and did not exit
  - Program attempted to access unused read-only memory
  - Program failed to check in occasionally

Analog circuits –  
Voltage went out of limits  
Oscillator failed  
Timing pulse generator failed

Each of the failures caused a restart, that is, a hardware-forced transfer out of the control law program to a software routine which performed several clearing and initialization steps in an attempt to correct the cause of the restart before allowing control law computations to continue. For some restart conditions, a signal was issued which caused a transfer to the backup control system.

The Apollo computer also monitored the performance of the inertial measurement unit (item 2, fig.8). Written into the software were decisions either to transfer the system to the backup control system for serious failures or to select the direct mode in the primary system for situations such as an inertial measurement unit accelerometer failure, which would affect only certain augmented modes.

Analysis of primary system failures showed the need for additional hardware failure detection circuitry (item 3, fig 8). The failure of certain channel outbits not monitored by the Apollo computer, in combination with normal pilot reactions, could have led to hazardous situations. These conditions first became apparent in piloted, closed-loop simulations using the iron bird simulator. The necessary hardware modifications were made and implemented in the system to circumvent these failure conditions or to cause a transfer to the backup control system when prevention was not possible.

Built-in test equipment for the backup system and primary electronics was provided in the pilot's side console. This self-test equipment could be activated only during preflight tests (paper 3).

## FLIGHT CONTROL SOFTWARE

Software flexibility made it possible to investigate a multimode F-8 digital flight control system using hardware that was designed for an entirely different purpose – guidance and navigation in space. The structure of the primary system control laws, which were implemented through software, and the associated logic functions are described.

### Control Law Modes

Control in each axis was provided in the control laws. The simplest form in each axis was the direct mode, illustrated in figure 9. The control law structure and gain settings were selected to be as close as possible to those of the backup control system. The first level of augmentation was rate feedback in the pitch and roll axes. Figure 10 illustrates these SAS modes as they were during flight tests. In the yaw axis, an aileron-to-rudder interconnect was included in addition to the yaw rate feedback (fig. 11). The most advanced type of control law was a blended



pitch rate and normal acceleration command augmentation mode, illustrated in figure 12.

The sampled-data aspect of the digital fly-by-wire system significantly affected the implementation of the software. The pitch SAS mode, illustrated in figure 13, was representative of the other augmented modes. A multirate sampling system was used, with a major cycle sample time,  $T$ , of 30 milliseconds and a minor cycle sample time,  $3T$ , of 90 milliseconds. Gimbal angles were transformed to body angles by using sines and cosines of gimbal angles updated once every minor cycle. A second-order rate estimator operating on these gimbal angles provided body rates, which were then filtered. General-purpose digital filters were programmed so that different characteristics could be selected independently for each feedback parameter. Proper selection of the difference equation coefficients could provide a wide range of filter characteristics. A first-order prefilter, a dead band, and a parabolic nonlinear gradient were available to shape the pilot's input.

### Logic Functions

An important capability made possible through software was the integration of logic statements in the control law code. Logic statements, even though complex, were easily written into the software. Had the system been analog rather than digital, special-purpose hardware would have been necessary to perform the same logic functions. One mode logic function associated with the yaw axis is discussed in reference 2.

Another type of logic function was the software reasonability test which was applied to each surface command before it was sent to the digital-to-analog converter. If the new command differed from the previous command by more than a predetermined amount, the affected axis would have transferred to the direct mode. This down mode philosophy was based on the assumption that a reasonability limit would be exceeded because of generic failures in the augmentation control laws rather than because of a hardware failure which would have affected the direct mode as well. It was assumed that a hardware failure would have been detected by the built-in Apollo computer fault detection logic.

Trim inputs were also tested for reasonability before the trim value was updated. If a combination of primary trim commands was sensed that corresponded to an impossible situation for an unfailed system, a failure was assumed, the primary trim was deactivated, and an auxiliary trim system was activated. A test for runaway trim was included which disabled trim updates if the trim command persisted for more than 3 seconds.

## DIGITAL FLY-BY-WIRE DESIGN

### Design Ground Rules

Several ground rules were established in order to meet the objectives of the

program. First, the airplane was to fly from the first flight without mechanical reversion capability. This forced the designers to take the care necessary to establish as much confidence in the system, including the software, as would be required for future active control applications. Second, the primary digital system was to utilize the hardware from the Apollo guidance and navigation system. The system was to remain intact; only software changes were allowed. The primary reason for this requirement was to retain the system's high degree of built-in integrity and reliability. A third basic design ground rule established early in the program was to make the pilot's interface with the computer as simple as possible. As a result, the pilot was given control over flight control functions rather than a direct communication with the computer. All functional changes (for example, a mode change) desired by the pilot were to be made through single switch actions. This allowed the pilot to perform functional changes rapidly and eliminated the possibility of incorrect entry or improper addressing which could have had dire consequences close to the ground or at high dynamic pressure. The last ground rule was to provide handling qualities that would be judged satisfactory by the pilots. A criterion based on  $C^*$  response to a step pitch stick command (ref. 3) was used as a guide during the design of the longitudinal control system. Military Specification MIL-F-8785B, level 1, was used during the lateral-directional control system design.

These ground rules had further implications. For example, the interface equipment associated with the Apollo hardware established limits on the flight envelope for satisfactory operation. The analog-to-digital converter used for pilot stick inputs had only 45 usable discrete levels between zero and full stick. In the pitch axis each discrete level resulted in a specific level of aircraft normal acceleration, depending on stick gearing and dynamic pressure. In this instance, the acceleration increment became objectionable to the pilot within the basic flight envelope. Thus a new flight envelope limit was established at the dynamic pressure at which the stick quantization effect was not objectionable. Because of the design characteristics of the inertial measurement unit, some additional restrictions were placed on the airplane's maneuverability. These included a roll angular rate limit of 70 deg/sec and a pitch attitude limit of 70°.

### Design Synthesis and Analysis

The closed-loop primary system was synthesized and analyzed by using two methods. The first was an analog sample and hold simulation which was useful in the learning process in that it pointed out the more general aspects of the digital control problem. For example, the acceptable range of sample rate, 25 to 50 samples per second, was defined. The effect of the folding phenomenon of sampled-data systems on the structural mode frequencies and the influence of common nonlinearities were also studied in this design phase. The second method used a digital synthesis program which provided linear analysis as a cross check and a background for the sample and hold simulation. Basic control laws, compensation, and logic were established by using these two methods. A specification for the control law software was then formulated, thus providing the basis for coding the flight software.

## Design Verification and Refinement

With the delivery of portions of the flight hardware, including the Apollo computer and the coupling data unit, and early releases of flight software, design verification and refinement was started. A six-degree-of-freedom digital aerodynamic model of the F-8C airplane was used in conjunction with the flight hardware to form a partial hardware hybrid simulation.

The first two analysis methods did not consider any pilot interface, but the partial hardware hybrid simulation included a lunar module hand controller with which the F-8C model could be crudely flown. Coarse input quantization, a problem of importance later, did not become evident in this simulation because it was completely masked by the characteristics of the hand controller. This is one of the major disadvantages of any simulation which does not include major hardware elements.

Another important tool in the design verification and refinement was the batch process all-digital simulation. This simulation included the software being verified, an Apollo computer emulator, and a program representing the F-8C aerodynamics, all run on a large host computer. Powerful plotting routines made the internal computer parameters visible during each run. All the control system parameters were examined for reasonableness, particularly as they responded to mode and gain changes. One of the most useful plots was duty cycle versus run time. A typical variation of duty cycle during a maneuver is shown in figure 14 for a roll step. Because of some additional code for computation of stick nonlinearities when the stick was displaced from zero, additional computational time was required during this maneuver. This was reflected in an increase in the duty cycle, as shown in the figure. Other contributions to duty cycle were the interrupts from the motion sensors. The increase in roll rate produced a loss in available computation time roughly proportional to the roll rate. This loss of computation time effectively increased the duty cycle.

The last step in the design verification used the iron bird simulator. One problem — the coarse quantization of the pilot's stick inputs — was uncovered immediately. The problem became obvious once the hand controller was replaced with the actual center stick. The staircase shape of the computer output commands produced sharp responses at the secondary actuators which were unacceptable from the standpoint of mechanical motion and structural element excitation. Low-pass filtering of the computer output was undesirable because of its adverse effect on closed-loop performance. This suggested the use of a digital pilot prefilter that had not been anticipated in the control law specifications. The flight software had already been substantially verified, but fortunately the read-only memory had not yet been manufactured. The prefilter was quickly programmed in software and the code was reverified. Consequently, there was essentially no effect on the overall schedule. This points out one of the significant advantages of a digital flight control system: Necessary changes can be made late in the design without affecting hardware procurement, packaging, or requalification. Although additional software verification will be required, it will not have the adverse effect on program schedules that is typical of a hardware redesign of an analog system.

Looking back on the various design and analysis tools, it is apparent that they

complemented one another. Confidence in the system grew each time an independent simulation or analysis gave results comparable to those obtained previously. The importance of having the pilot in the loop with as much actual hardware as possible was demonstrated vividly. In terms of time spent on verifying the various aspects of the design, the largest proportion was devoted to systematically verifying each logic function and mode transfer and the effects of failures. Another time-consuming aspect was the refinement of stick gradients and nonlinearities near zero stick. A much smaller proportion of time was spent on closed-loop augmentation characteristics, probably because of the good agreement generally found between the results from sampled-data analysis methods and simulation results.

## RELATIONSHIP TO FUTURE APPLICATIONS

The configurations of future fly-by-wire systems will probably be strongly dependent on the specific missions for which they are designed. As such, each system will be unique in some respects, but will have a large degree of commonality with other fly-by-wire systems. The F-8 fly-by-wire system was unique in that it consisted of a simplex digital primary system, a triplex analog backup system, and no mechanical reversion capability. However, in this unique system were several features that will be relevant to the systems that will be required to achieve the advantages that active control offers. These features were, basically, dissimilar redundancy, single string software, and the experience associated with the digital system design.

### Dissimilar Redundancy

The F-8 fly-by-wire system experience with two dissimilar systems provides information applicable to future systems which are likely to have dissimilar redundancy. Most of the problems were concerned with the synchronization of the two systems. Transfers from one system to another were handled differently, but the goal was to minimize transients caused by the transfer. In each instance, the system in control was tracked by the other system so that transients would be minimized. However, the primary system tracked the backup system by estimating the surface command of the backup system based on the pilot's control commands and trim inputs only. In transfers from the primary system to the backup system, the backup system tracked the output of the primary system. Although this eliminated the need to reconstruct the primary system signal propagation in the backup system, it did open the possibility for unusual initialization conditions when the transfer occurred during an abrupt maneuver. Another factor was that a transfer from the primary system to the backup system could have been initiated automatically as a result of a failure, thus the failure analysis had to consider all possible failures that could have resulted in a transfer. The timing of this transfer was critical in some instances when it could have coupled with the pilot's normal response to cause unacceptable conditions.

Some aspects of the dissimilar redundant system gave insight into redundancy management problems which may be expected in the future. The backup system

mechanized the trim function using a digital integrator to reduce drift. Because of differences in the sampling mechanisms between the two systems, large errors between the two trim signals were noted after extended flight with the backup system in control in which numerous trim inputs were made. Figure 15 illustrates the two sampling mechanisms. The primary system sampled trim commands every 90 milliseconds. If trim was being commanded at the time of the sample, the trim value was updated in the software. The backup control system did not update its digital trim integrator until a capacitor was charged up to a prescribed threshold. Although the capacitor began charging the instant the trim button was pushed, approximately 175 milliseconds were required before the first update of trim. As a result of these two sampling mechanisms, trim inputs of less than 175 milliseconds, but greater than 90 milliseconds, caused the primary system, but not the backup system, to update trim. To correct the problem, there would have had to be either some exchange of actual trim value information between the two systems or some form of verification that one system received the trim command before the other system updated the trim value. Each of these possible solutions would have required additional connections between the two systems, which would have been undesirable because they would have created new failure possibilities. For this particular research application, a procedural change in conjunction with close monitoring of telemetered data in the control room made modification of the system unnecessary.

### Single String Software

Because a simplex digital system can have only a single program in control at one time, it can be described as a system with single string software. However, redundant digital systems with the same program in each computer also effectively have single string software. The experiences with the F-8 digital system software are closely related, then, to the multichannel digital systems expected in future civil transports. Generic software failures would have equivalent effects on any system with single string software, regardless of the system's redundancy. The software controls described in paper 5 suggest that careful verification will always be necessary, but that the confidence necessary for man-rating the software can be established.

Another factor that emphasized the importance of man-rated software was that the single string software had full-authority control over the control surfaces; thus it was obviously flight critical. Digital systems will be called on to perform more and more flight-critical functions and, on the basis of our experience, can be depended on to perform with high integrity.

Removal of all mechanical reversion capability before the first flight had a significant effect on the entire design and verification process. It forced an approach that would establish complete confidence in the system on the basis of simulation alone. If the alternate approach had been taken, that of retaining a mechanical link, the most probable flight-test procedure would have been to fly to a safe altitude using the mechanical system and then engage the fly-by-wire system. After confidence was gained at altitude, the more critical flight safety functions, such as takeoff and landing, would have been encompassed gradually.

## Design Experience

On the basis of the F-8 digital fly-by-wire design experience, several recommendations can be made regarding the design of digital control systems for future civil transports. Many of these recommendations correspond simply to good design practice. Analyzing closed-loop performance using standard sampled-data analysis techniques such as z-plane root locus can be relied on to give good agreement with more complete simulations. Several forms of simulation and analysis should be used to build confidence in the system before the first flight. A simulation that includes as much actual hardware as possible is important in correctly assessing system performance. The interface with the pilot is particularly important.

## CONCLUDING REMARKS

The feasibility of a digital fly-by-wire system was assessed by replacing the mechanical flight control system of an F-8C airplane with a digital primary and an analog backup fly-by-wire system. The design and verification procedures which will be necessary if flight-critical active control is to be used in future aircraft were established and successfully applied as part of the flight program. Careful application of standard sampled-data design methods and systematic verification of control system hardware and software using complete simulations resulted in a digital fly-by-wire system with extremely high integrity. The successful use of single string software in a full-authority flight control system demonstrated the high level of confidence which can be placed in digital flight control.

The experience with the F-8 digital fly-by-wire system pointed up several factors that will be important in the successful design of future full-time, flight-critical digital control systems:

(1) Batch process all-digital simulation was extremely helpful in tracing internal computer variables and in providing visibility to system response during mode changes.

(2) A complete piloted simulation with actual flight control system hardware provided important results relative to the pilot/stick interface that had not been obtained in earlier simulations which did not include the actual control stick.

(3) The largest portion of the design and verification effort was devoted to logic functions, such as mode transfers, and the effects of failures.

(4) Software changes made late in the design to correct hardware-related problems had a negligible effect on the program schedule.

A major aspect of the F-8 digital fly-by-wire system which will have application to future systems was its dissimilar redundancy. Failure isolation between the primary and the backup systems was achieved as desired, although some problems were encountered with intersystem synchronization.

## REFERENCES

1. Miller, J. E., ed.: Space Navigation Guidance and Control. Technivision Limited (Maidenhead, England), c.1966.
2. Deets, Dwain A.; and Szalai, Kenneth J.: Design and Flight Experience With a Digital Fly-By-Wire Control System in an F-8 Airplane. Advances in Control Systems. AGARD-CP-137, May 1974, pp. 21-1-21-10.
3. Tobie, Harold N.; Malcom, Lawrence G.; and Elliott, Elden M.: A New Longitudinal Handling Qualities Criterion. NAECON/66; Proceedings of the IEEE 18th Annual National Aerospace Electronics Conference, May 1966, pp. 93-99.

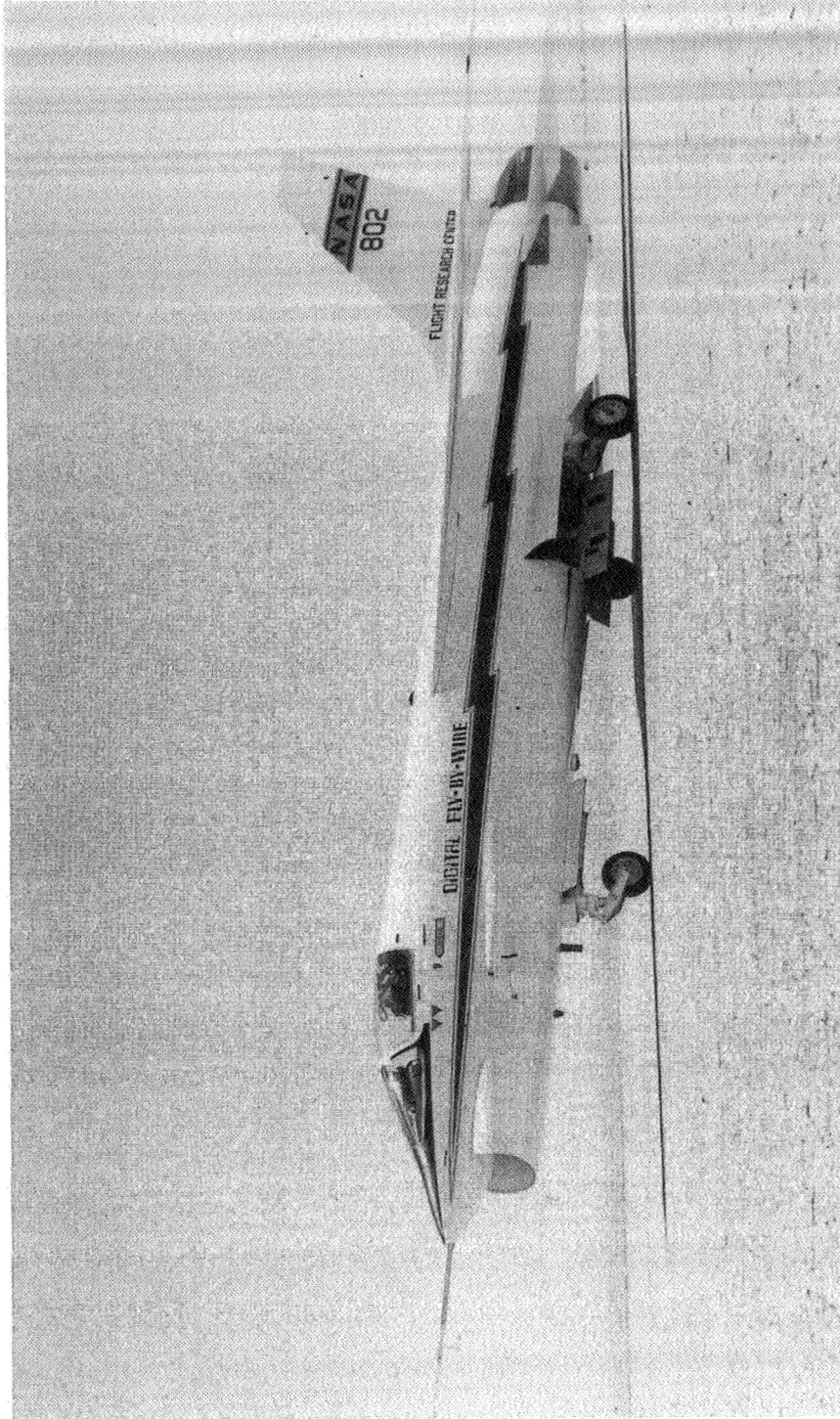
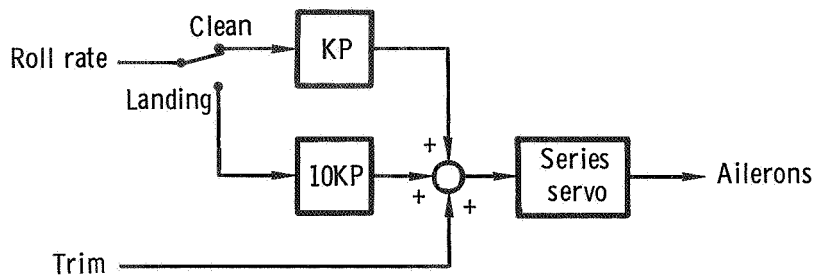

Figure 1. F-8 digital fly-by-wire airplane.

E-24823





(a) Roll-axis damper.

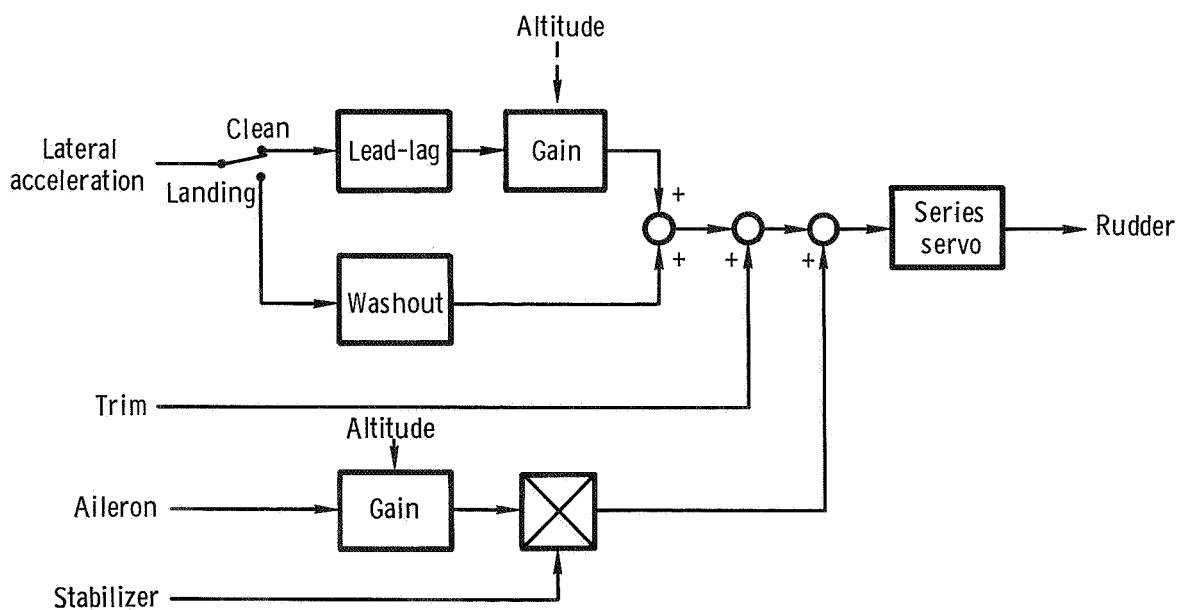

(b) Yaw-axis damper.

Figure 2. Standard F-8C roll and yaw stability augmentation systems.

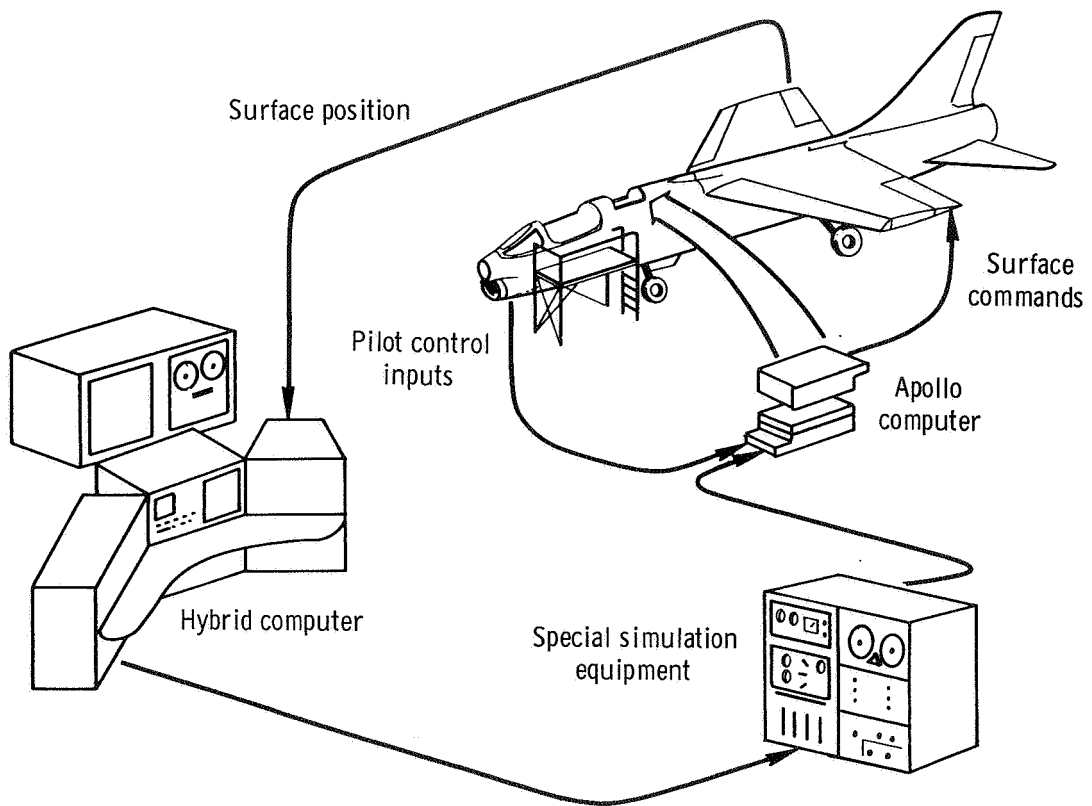

Figure 3. F-8C iron bird simulator .

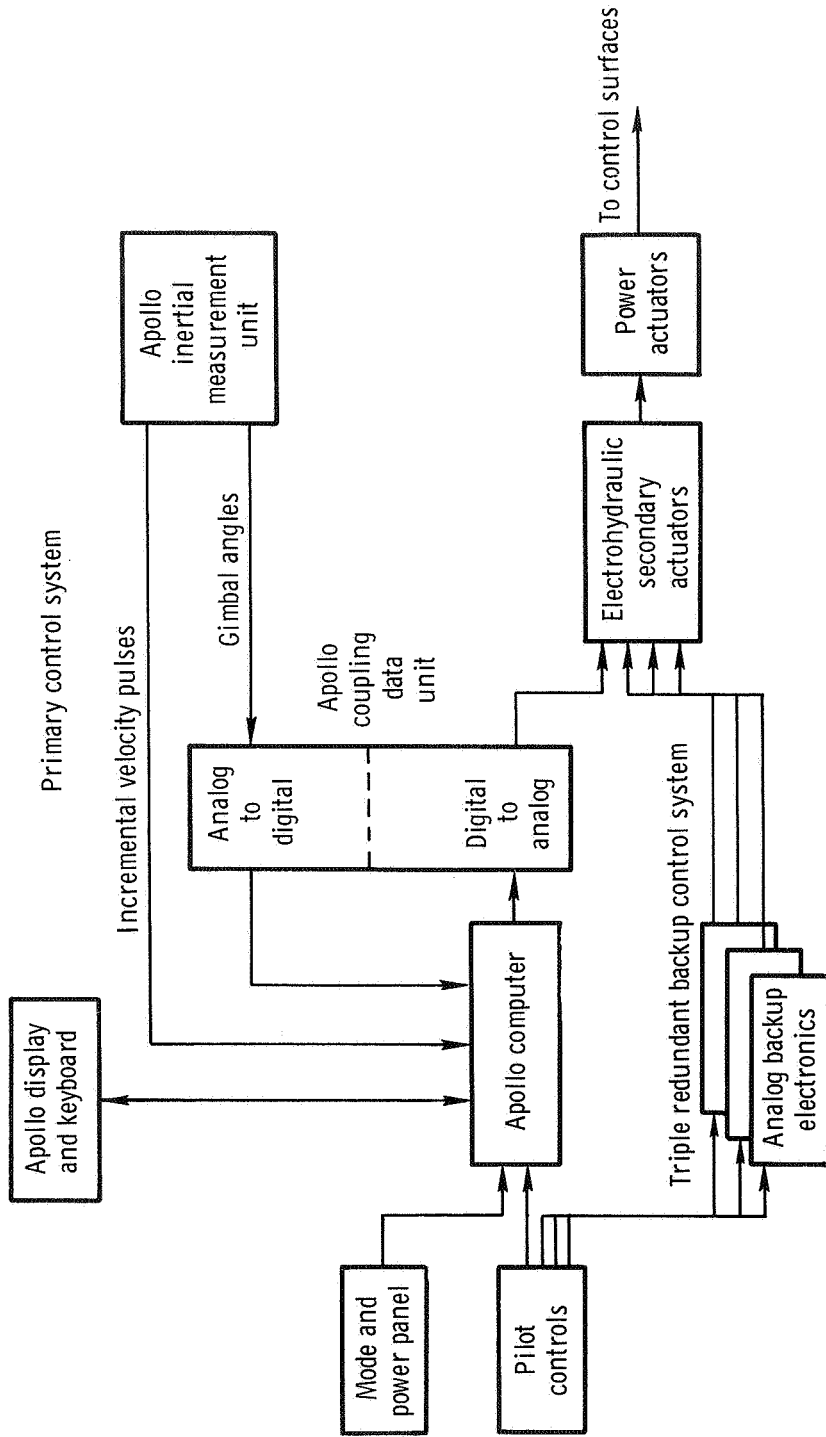

Figure 4. F-8 digital fly-by-wire control system components.

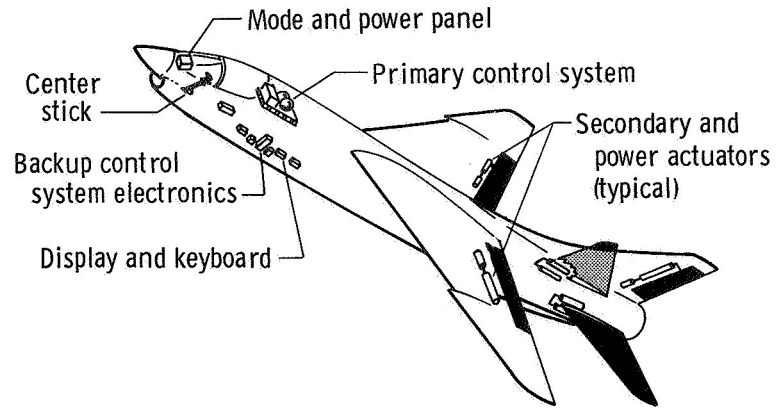

Figure 5. Location of fly-by-wire control system components in F-8C airplane.

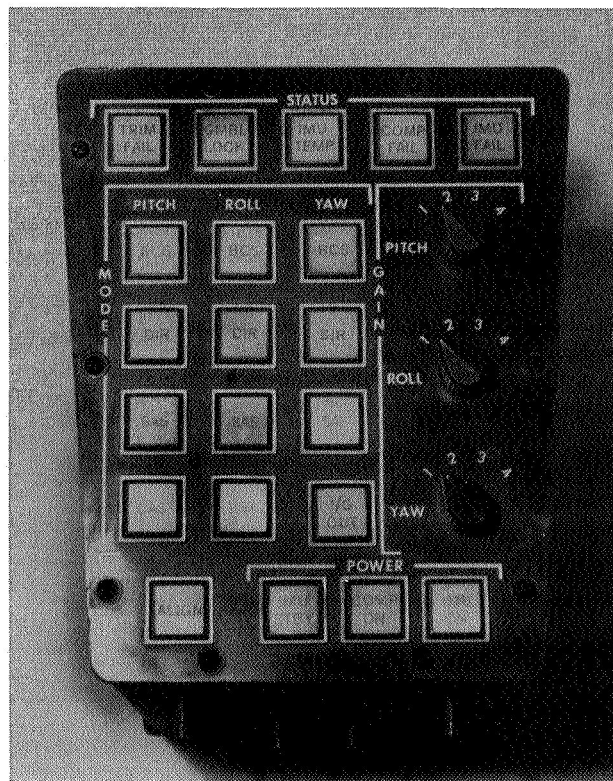

Figure 6. Mode and power panel.

E-23983

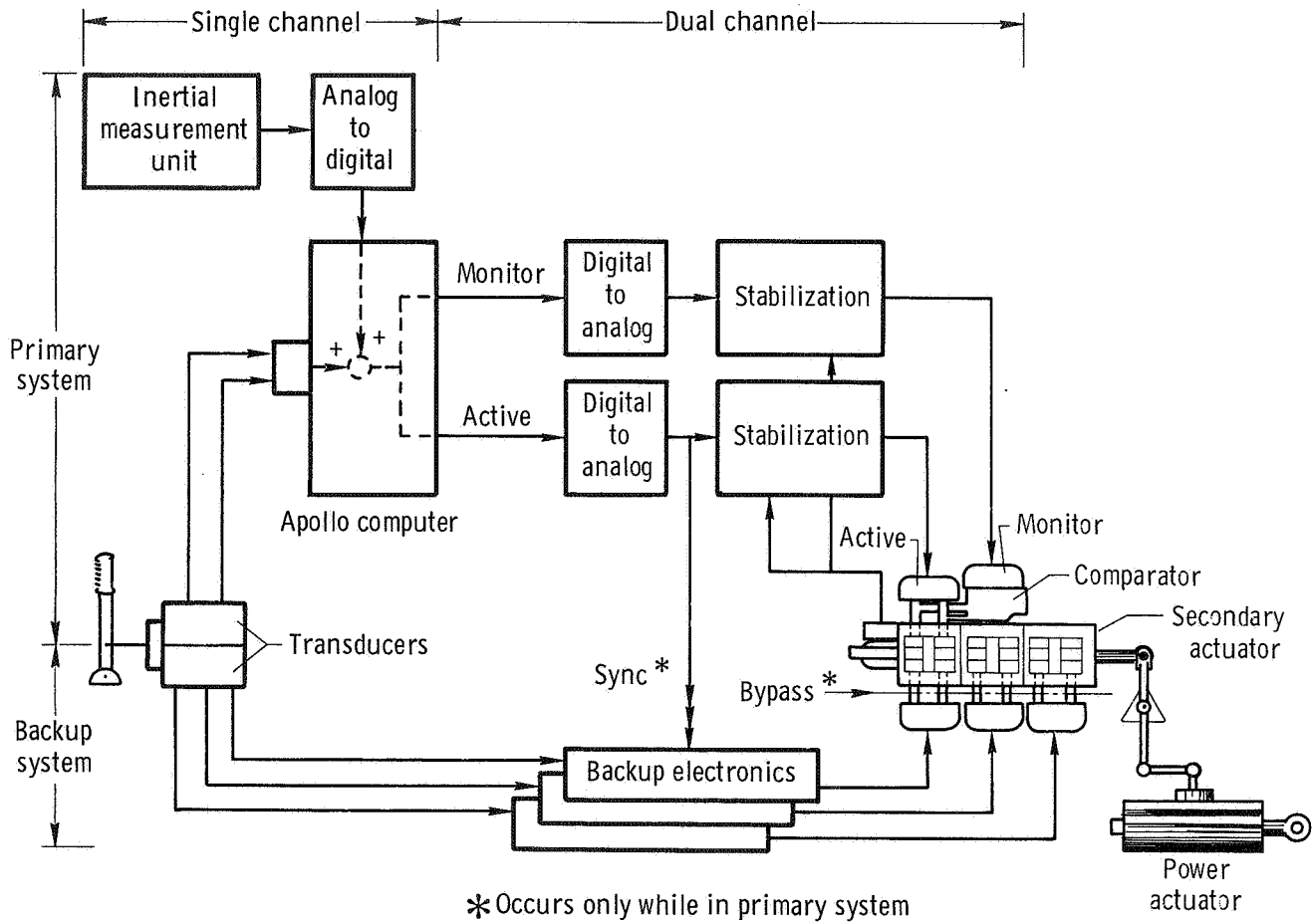

Figure 7. F-8 digital fly-by-wire system mechanization.

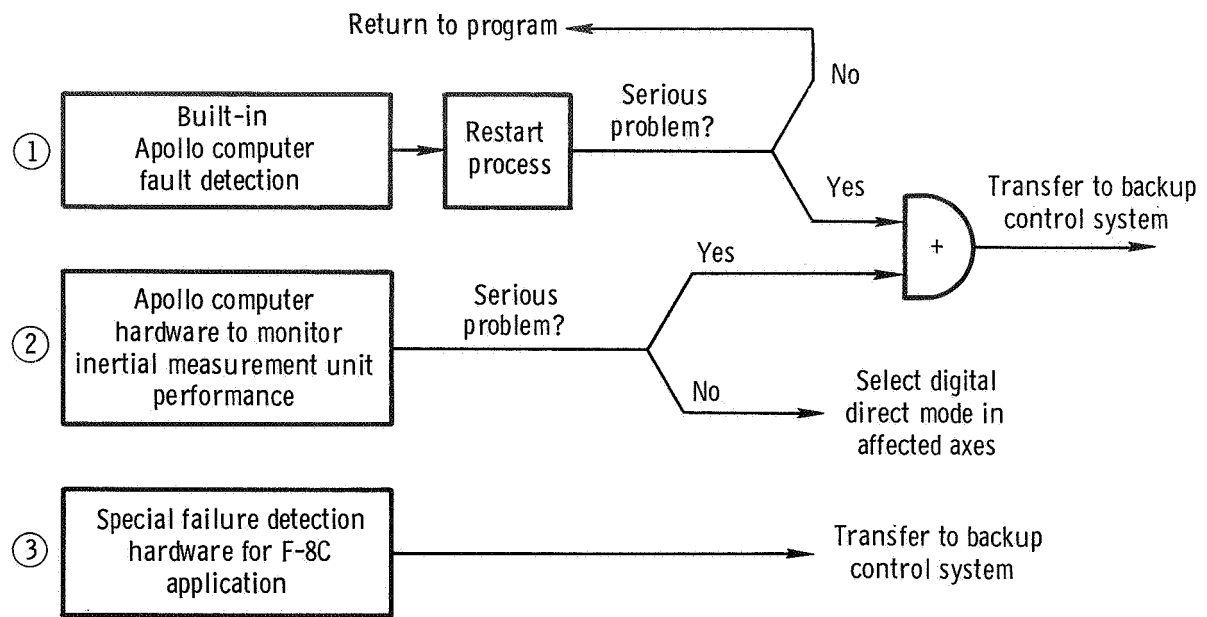

Figure 8. Digital system failure detection and reporting system.

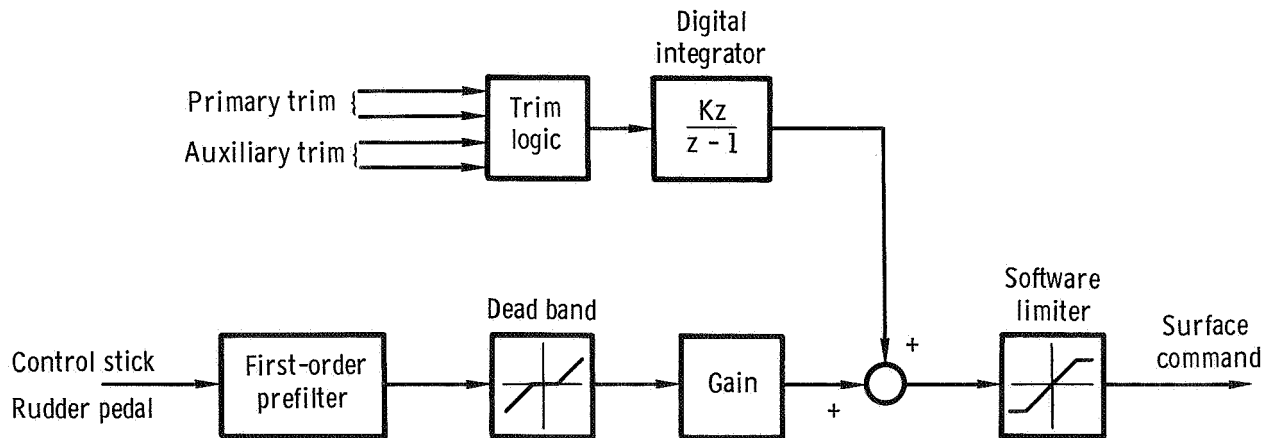

Figure 9. Direct modes for pitch, roll, and yaw axes.

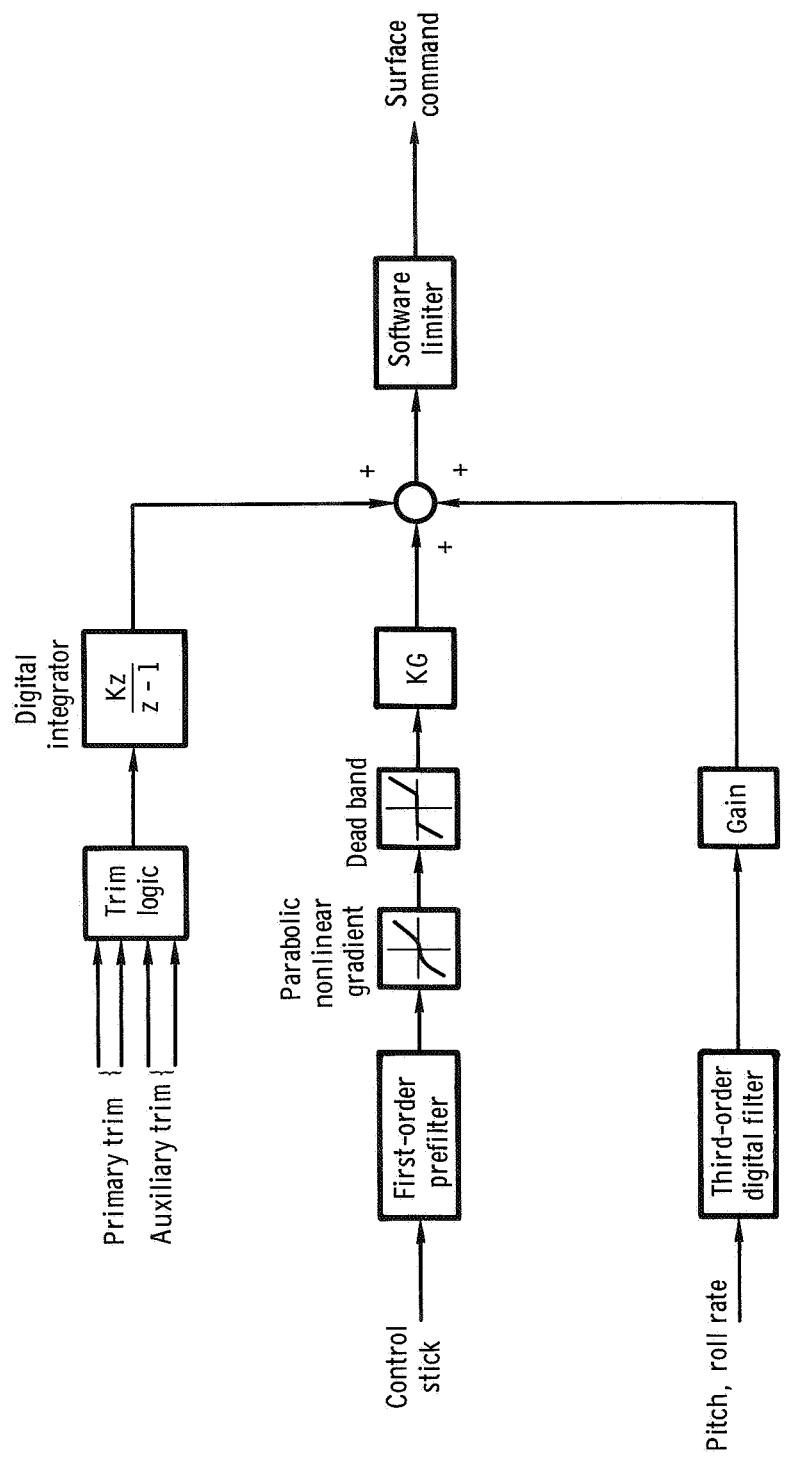

Figure 10. Pitch and roll stability augmentation systems.

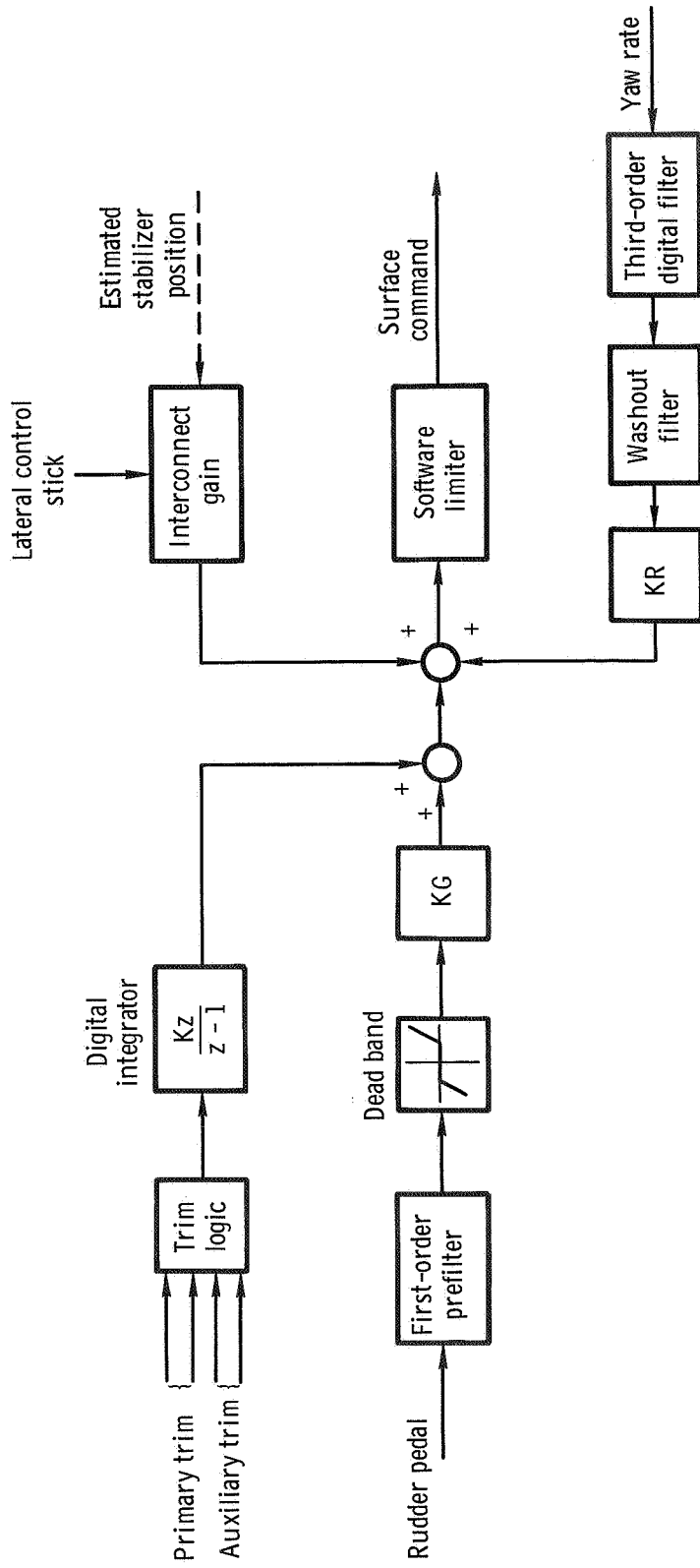

Figure 11. Yaw stability augmentation system .



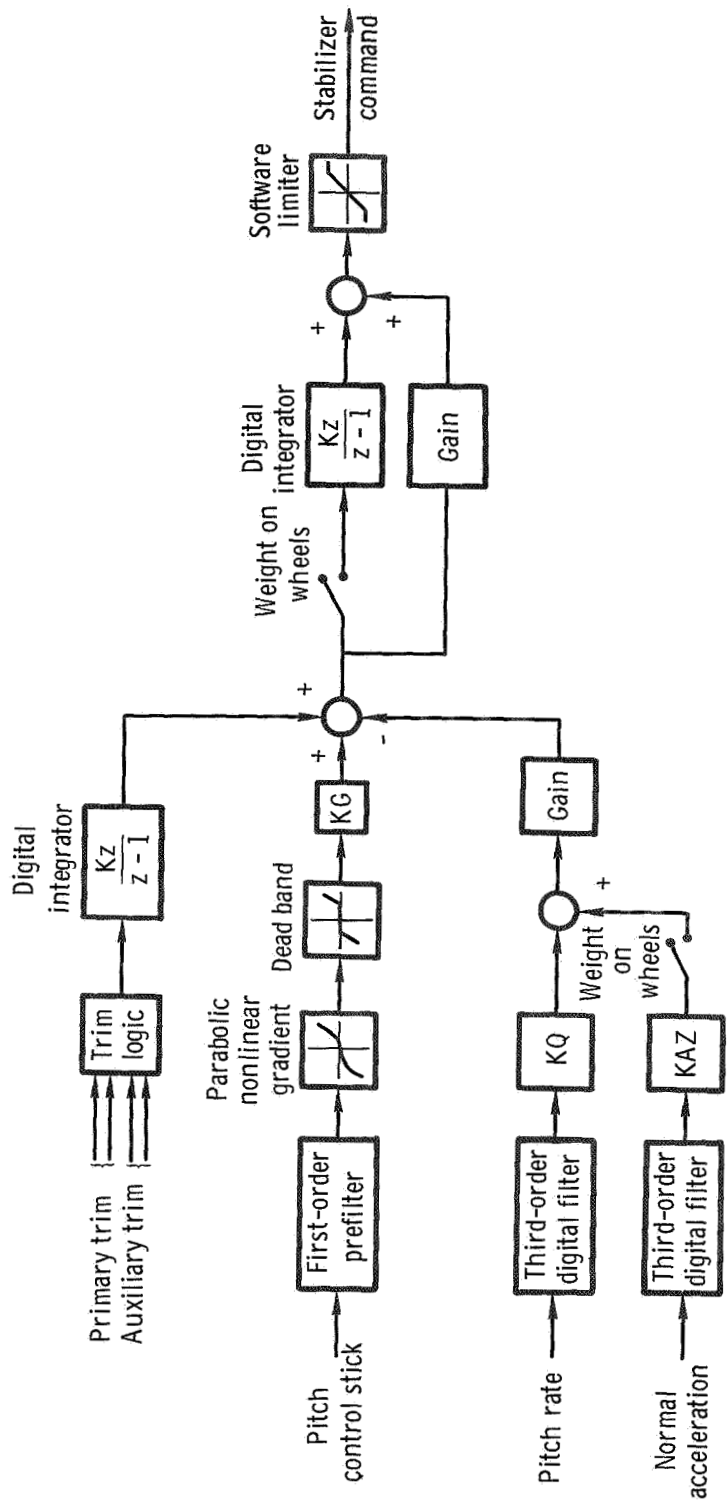

Figure 12. Pitch command augmentation system.

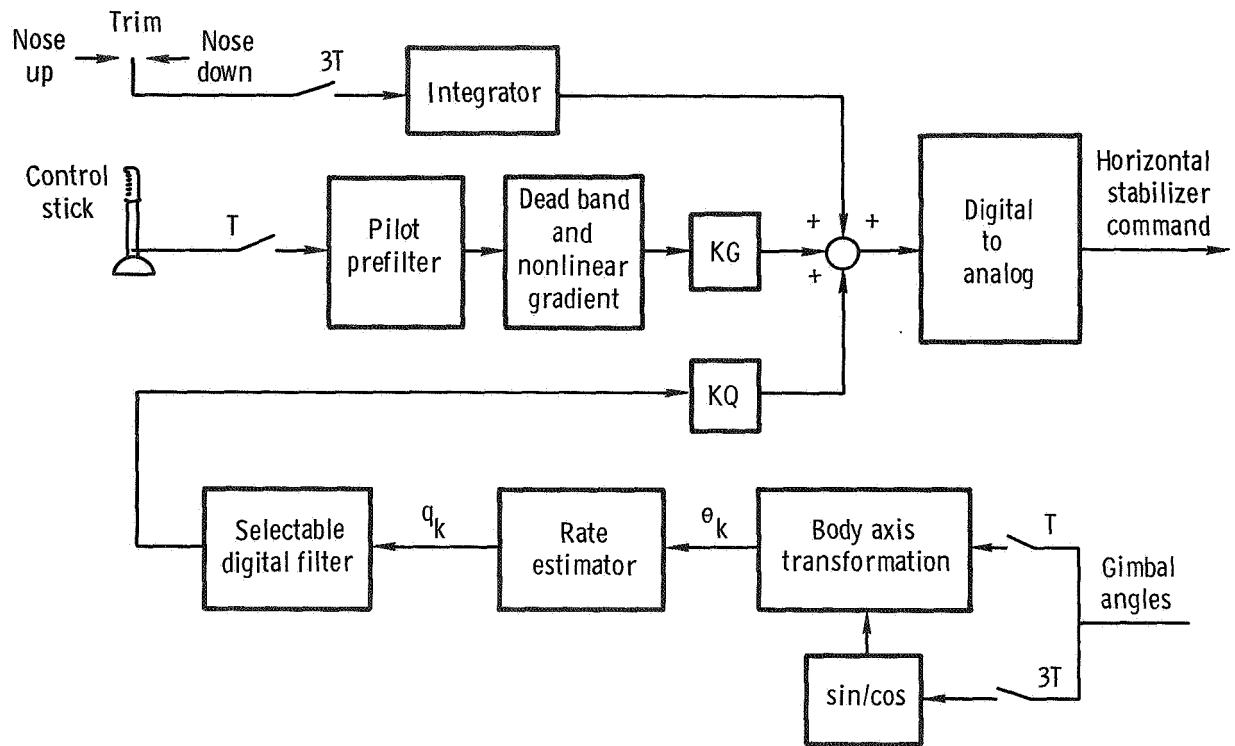

Figure 13. Pitch stability augmentation system mode as a sampled-data system.

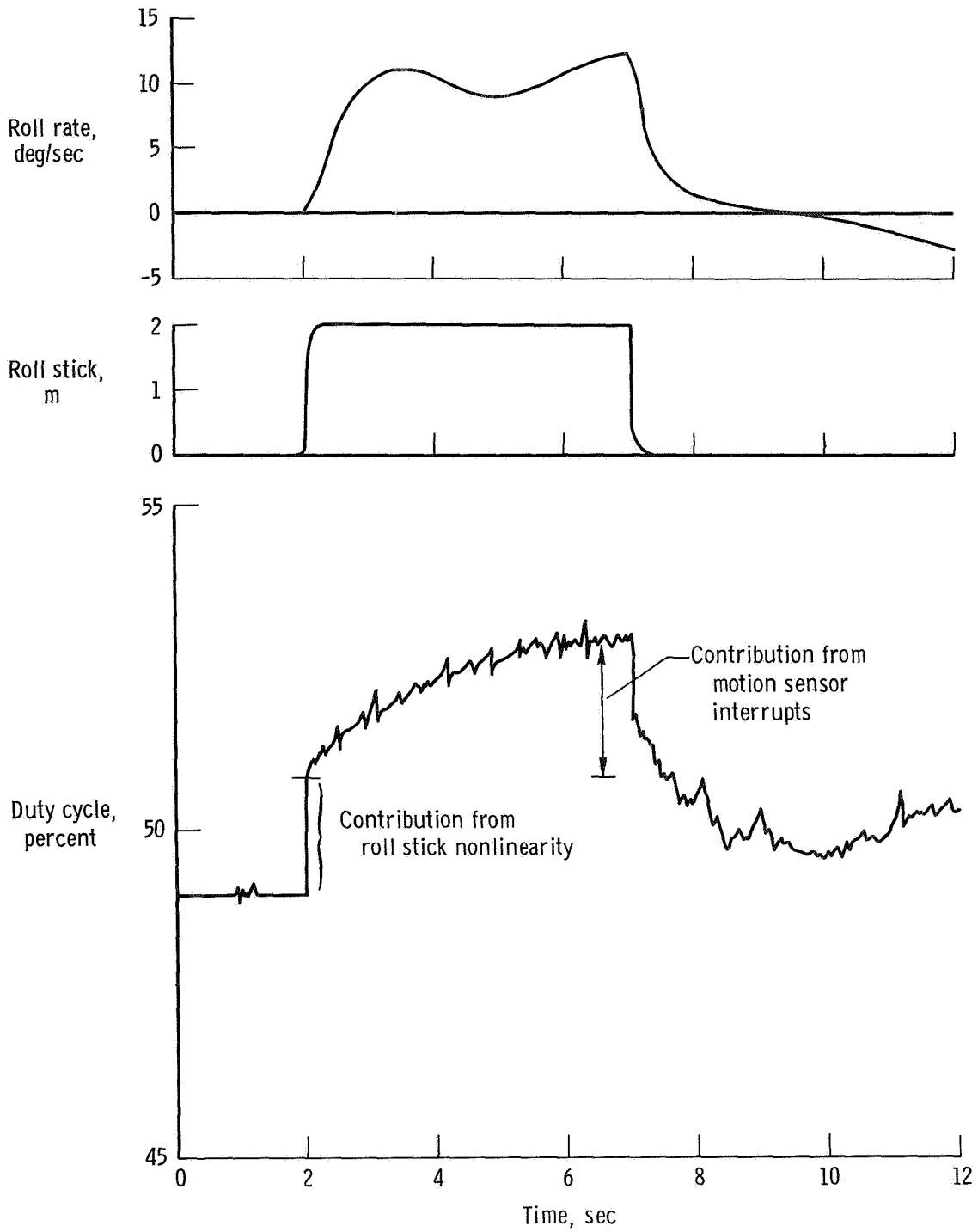

Figure 14. Duty cycle variation during roll step maneuver .

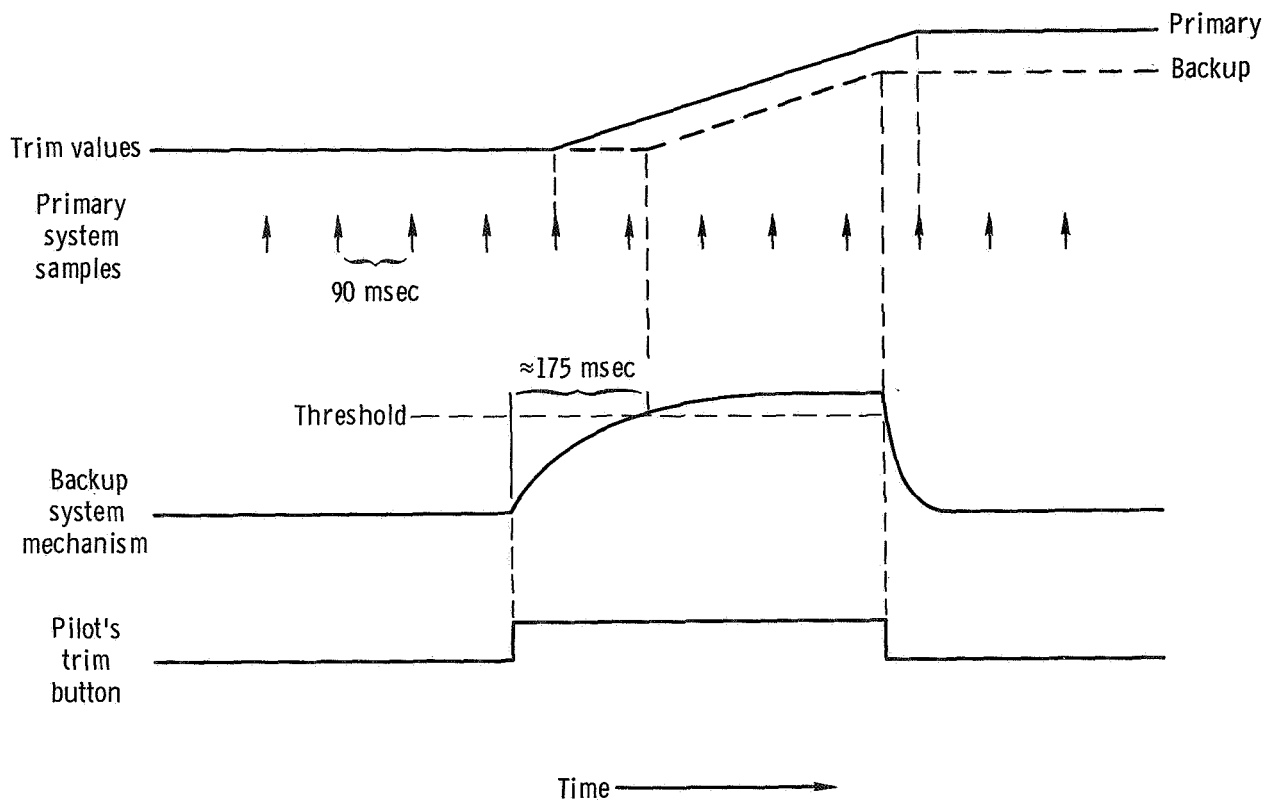

Figure 15. Trim sampling mechanisms of the primary and backup systems.

### 3. MECHANIZATION OF AND EXPERIENCE WITH A TRIPLEX FLY-BY-WIRE BACKUP CONTROL SYSTEM

Wilton P. Lock and William R. Petersen  
NASA Flight Research Center

and

Gaylon B. Whitman  
Sperry Flight Systems Division

#### SUMMARY

A redundant three-axis analog control system was designed and developed to back up a digital fly-by-wire control system for an F-8C airplane. Forty-two flights, involving 58 hours of flight time, were flown by six pilots. The mechanization and operational experience with the backup control system, the problems involved in synchronizing it with the primary system, and the reliability of the system are discussed.

The backup control system was dissimilar to the primary system, and it provided satisfactory handling through the flight envelope evaluated. Limited flight tests of a variety of control tasks showed that control was also satisfactory when the backup control system was controlled by a minimum-displacement (force) side stick.

The operational reliability of the F-8 digital fly-by-wire control system was satisfactory, with no unintentional downmodes to the backup control system in flight. The ground and flight reliability of the system's components is discussed.

#### INTRODUCTION

A control system consisting of a primary digital fly-by-wire system and a dissimilar triplex analog backup system was flight tested in an F-8C airplane by the NASA Flight Research Center. The mechanical linkages of the original F-8C control system were removed except for cockpit stick and pedal centering and feel. A single channel digital computer, the associated electronics, a power-generating system, and electrohydraulic secondary actuators made up the primary control

system. A triplex backup control system provided the redundancy required for manned flight and gave the total system two-failure-operate reliability.

The main components of the backup control system were the sensors, the electronics, and the secondary actuators. The system was analog for signal processing, had no feedback for stability augmentation, and was designed to provide emergency return-home capability with airplane handling qualities equal to those of the basic F-8C airplane. The F-8C airplane can be flown through most of its flight envelope without augmentation.

This paper describes the backup control system and its integration with the primary control system, which is described in detail in paper 2. The mechanization of and operational experience with the primary and backup control systems are discussed. Some aspects of the primary and backup control system design were unique; however, many of the design features would apply to fly-by-wire control systems in active control aircraft. The reliability of the total system during the program is described.

A limited flight test evaluation of the backup control system was conducted using a minimum-displacement (force) side stick controller for pitch and roll control. These evaluations represent most of the maneuvering experience with the backup control system.

## DESIGN FEATURES

The backup control system was designed to provide redundancy for the F-8 digital fly-by-wire control system. It was a triplex analog fly-by-wire control-stick-to-control-surface system in which the electronic trim, sensor and electronics equalization, primary control system synchronization, and servo and electronics monitoring were independent of the primary control system. The system incorporated several innovations that are common in modern electronics equipment but not as common in airplane control system hardware. These design features are described in the following sections.

A functional block diagram of the F-8 digital fly-by-wire control system is presented in figure 1. The upper portion of the figure is the primary control system, and the lower portion is the backup control system. The secondary actuators are shared between the primary and backup systems, and the primary control electronics provide the interface between the digital-to-analog converters of the primary system. The secondary actuators and the synchronization between the primary and backup systems are also discussed in this paper.

### Triplex Channels

The backup control system consisted of three identical computing channels, one for each airplane control axis. The system provided an interface between the

triplex control stick and pedal position sensors and the triplex servovalves. In addition, the three backup control system channels, including the sensors, electronics, and servos, were powered by three isolated power busses that were connected to a common power source.

The servo commands, which consisted of stick and pedal commands that were summed with the trim and equalization signals, were processed by voters in each channel to insure that the three backup channels tracked. The voter selected the middle value of the three channel commands to drive the control valve in each channel. For certain types of failures in the voter, actuator, or servo electronics, the failed channel would be detected and the servovalve associated with the failed channel would be disengaged. Therefore, the backup control system was operational after one or more failures.

### Synchronization

An integrator in each axis of the three backup control system channels provided electronic trim, equalization, and synchronization. When a primary channel was engaged, the backup control system servo commands were synchronized with the primary servo commands with these integrators. These inputs to the backup control system voters tracked the primary channel servo commands, even though variations in control sensor outputs and in intersystem control laws existed. Continuous synchronization of the backup with the primary control system was necessary to minimize control surface transients during the switchover from the primary to the backup control system. Switchover occurred if there was a failure in the primary system or if disengagement was commanded by the pilot. The synchronization network had a bandwidth of approximately 2.5 hertz.

### Equalization and Trim

When the backup control system was engaged, the integrators performed the backup control system trim and equalization function. Trim was accomplished by applying a fixed reference to the integrator, changing trim at a fixed rate. The integrator output was then summed with the control stick or pedal position inputs to form the total surface command. Since the trim inputs, sensor position inputs, and electronic gains were not necessarily the same in each backup control system channel, equalization was included to reduce errors between channels. Limited equalization, combined with the voters, produced essentially identical channel servo commands to the three backup control system servovalves and minimized the force fight between the secondary actuator pistons.

The trim and equalization functions required a low or zero drift integrator. The backup control system integrator design, which was classified as having zero drift, used digital techniques to accomplish the zero drift or memory function and analog techniques for the integration function.

## Backup Control System Monitoring

Electronic and servo signals were monitored at two points within the backup control system. The channel voter output was compared with the voter input. If the signal difference was greater than the set threshold, the monitor was latched and the electronic channel was reported failed.

The other monitoring point was the backup control system servos. Backup control system servo monitoring was accomplished by cross-channel comparison of the differential pressure signals from each of the three servovalves. This detected excessive force fights within the backup control system servos. A preset difference in two of the three differential pressure signals resulted in latching the common servo monitor, disengaging the failed servo, and reporting the failure to the pilot. When a failure was detected and the failed servo disengaged, the resulting surface transient was minimized by the operating characteristics of the force-summed actuator.

## Self-Test Procedure

Preflight testing was accomplished by an automatic self-test procedure that provided a pseudo-end-to-end testing of the system. The self-test involved the introduction of a logic-controlled stimulus and the disabling of circuit functions and used in-flight monitors to indicate the response. The use of the in-flight monitors as the self-test feedback elements served to check the channel signal paths and the operation of the in-flight monitors. This resulted in a "bang-bang" type of test with no indication of system degradation.

A block diagram of the self-test unit is shown in figure 2. The power for the self-test was routed to the computing electronic assemblies only after the self-test power switch was closed and the self-test start switch was depressed. A counter started to count and addressed the read-only memory, which was preprogrammed for each particular test to activate certain stimuli and disable certain circuits in the electronic assemblies. The test results were compared with the predicted results, which were stored in the read-only memories in the diagnostic analysis circuitry. The self-test automatically stepped to the next test if the test results were as predicted. This procedure was repeated with different combinations of stimuli and disabling circuits active until the test was complete and a GO signal was reported in each airplane control axis.

If the test results from the electronic assemblies were not as predicted, the test sequence was stopped and a diagnostic routine was initiated. The diagnostic analysis circuitry analyzed the test results with respect to the predicted results to determine where the failure occurred. The diagnosis was indicated on the self-test diagnostic readout.

## Status Engage Panel

The status engage panel was in the left cockpit console. It housed all the servo engage switches and servo status lights and indicated the status of the



backup control system electronics. The panel also contained the self-test program, power switch, and diagnostic readout to indicate a failed self-test condition or satisfactory completion of the self-test. The servo switches were three-position positive-action switches labeled Auto-Off and Manual. Even though five secondary actuators were utilized for the three control system axes, only three switches and servo status lights were used for the three primary control channels, whereas individual channel switches and status lights were mechanized for each backup control valve. The lights indicated when the various comparator networks had exceeded preset values. The light was also a reset switch that sent a reset pulse to its comparator. The servo status lights for backup servo systems 2, 3, and 4 lit up after any two common comparators tripped. That is, the left pitch 2-3 comparator and the left pitch 4-2 comparator lit the left pitch number 2 light when both comparators tripped. The logic for the primary control system pitch servos was that if either the left or the right pitch channel indicated failure, the number 1 pitch status light lit, and control was switched from the primary to the backup control system. The servo system logic was designed to provide a manual override capability for any channel per actuator regardless of the remaining servo system switch positions.

## SYSTEM COMPONENTS

The approximate locations of the control system components in the F-8 digital fly-by-wire test airplane are shown in figure 3. As might be expected, using the F-8C airplane as a test-bed resulted in some design problems that were unique to the F-8C configuration. A major problem was the requirement for different control gearing for the wing-up (approach and landing) and wing-down (cruise) positions. A pair of dual wing potentiometers was mounted to provide an electrical signal proportional to wing position to droop the ailerons for flaps and to provide automatic trim of the horizontal tail. Other system components that provided control, signal conditioning, and actuation are described below.

### Control

*Stick and pedal transducers.* — Two transducers that each contained triplex redundant linear variable differential transformers (LVDT's) were connected to the existing F-8C flight control linkage to provide electrical signals as functions of the pilot's stick and rudder commands. One transducer was provided for the primary control system, and one was provided for the backup control system for each airplane axis of control. The pitch transducers were on the right and the roll transducers were on the left side of the airplane underneath the primary flight pallet. Because of rudder cable stretch, the two rudder transducers were installed in the base of the vertical tail.

Each transducer assembly contained isolated sensors for excitation and signal output to drive as many as three separate control paths. All the transducers were linear, except for the pitch transducers for the backup control system, and all had an electrical stroke of  $\pm 1.5$  centimeters. The pitch transducer for the backup control system transducer had a special winding to provide parabolic stick shaping.

*Stick and pedal gearing.* — An attempt was made to duplicate the control authority and gearing of the original F-8C airplane in the F-8 digital fly-by-wire airplane. The final gearings are shown in figures 4(a) to 4(c) for the pitch, roll, and yaw axes.

The data presented in figure 4(a) indicate that there was reasonable agreement between the pitch stick gearing of the fly-by-wire airplane and that of a conventional F-8C airplane. Only the wing-down data are presented for zero trim command. With the wing in the up position, the horizontal stabilizer surface was biased  $5^\circ$  from the wing-down position, and the zero stick position corresponded to zero surface position.

Figure 4(b) shows the left aileron position as a function of lateral stick position for a wing-down and a wing-up configuration with zero trim command. The gradients are nearly the same for all backup control system commands except for the wing-up right stick command, where the gradient is higher than in the conventional F-8C airplane. The fly-by-wire gradients were symmetrical for both wing positions, whereas the wing-up gradient was not symmetrical (differential aileron) for the conventional F-8C airplane. The aileron did not move down as far as it moved up for a given stick command.

Figure 4(c) shows rudder displacement as a function of pedal force. Gradients are shown for the wing-up and the wing-down configurations. The higher gradient was used with the wing-down configuration. The pedal forces were provided by the existing F-8C mechanism. The gradients show good agreement for both wing positions. The backup control system deadband was slightly larger.

*Side stick.* — The side stick sensor flight tested during the program was a two-axis, four-channel, minimum-displacement transducer. The principal of operation for the transducer was that an applied force at the stick grip caused a flexure-supported tube assembly to move quadruplex LVDT's that generated a voltage proportional to the applied force. The side stick transducer was recessed in the right cockpit console to allow the pilot to sit comfortably in the seat with his arm in a natural position.

*Side stick gradients.* — The side stick gradients flight tested are shown in figures 5(a) and 5(b) for the pitch and roll axes, respectively. Figure 5(a) shows the pitch stick force as a function of elevator surface position for both wing positions. The circuit mechanization consisted of a deadband, a low gradient, and a high gradient for both a pull and a push force. The variable high gradient was mechanized to function only with the wing down, and it was controlled by a switch in the cockpit. In figures 5(a) and 5(b), switch positions increase with increasing stick gradient. The side stick authority was always less than the center stick authority.

## Electronics

*Backup control system.* — Three identical backup control system electronics boxes were the heart of the backup control system. Each box contained all the

signal processing, engage logic, monitoring, and dc power necessary for a single backup control system channel in the pitch, roll, and yaw axes. A block diagram of a single channel in the roll axis (channel 3) is shown in figure 6. Except for scaling, trim rate, and the gearing change with wing position, the network for the pitch axis was basically the same. The yaw axis differed in scaling and trim rate, and a limiter was added just after the voter. The voter output drove only one actuator network.

Figure 6 shows one electrical comparator across the voter and a single comparator across each backup valve. In total, there were eight comparators per backup control electronics box. The trip level of the electrical comparators was set at 3.0 volts, which was approximately one-third the maximum voltage for each axis. This corresponds to a stick displacement of approximately 2.5 centimeters for roll and 5 centimeters for pitch. The differential pressure comparators were set to trip at 2.4 volts, which represents a differential pressure error of  $8273 \text{ kN/m}^2$ .

*Primary control electronics.*— The primary control system electronics box contained the signal interface between the computer's digital-to-analog converter outputs and each secondary actuator for the airplane's pitch, roll, and yaw axes. A simplified block diagram of a typical primary signal circuit is shown in figure 7. For each control axis, there were two identical signal paths, the active and monitor channels, from the computer to the control valves of the respective secondary actuator. The primary control electronics box contained two 5-hertz second-order smoothing filters in each of the three axes. Follow-up signals from the secondary actuator were biased with the wing position voltage for the pitch and roll actuators. The signal was then divided for summing and sent directly to the monitor servo amplifier or quadruplex voter and processed with the three comparable signals from the backup control system. In conjunction with the hydrologic comparator, this provided hard-over protection from open servo follow-up signals.

The primary control electronics box also contained engage logic, monitoring, and the dc power supply for the box and the primary secondary actuators. A separate return comparator was used to monitor the difference between comparable points in each axis of the primary and backup control systems. When the error was greater than  $3^\circ$ ,  $4^\circ$ , and  $3^\circ$  for the elevator, aileron, and rudder, respectively, the primary control system could not be engaged. However, the backup control system could always be selected.

*Side stick electronics.*— The installation of a side stick required additional electronics that could not be readily added to the backup control electronics boxes. Therefore, the additional electronic networks needed to provide demodulation, deadband, shaping, and gradient (fig. 8) were mechanized to interface between the side stick transducer and the backup control electronics boxes. The triplex electronics concept was maintained from sensor output to the appropriate channel sum points in the backup control electronics boxes.

## Secondary Actuators

The secondary actuator (fig. 9) was a four-channel electrohydraulic actuator designed to convert electrical signals to surface motion and to have two-fail-operate

capability. There were five secondary actuators: two for roll, two for pitch, and one for yaw. The mechanization of the secondary actuator was an active/standby configuration which consisted of two valves in the active configuration and three valves in the standby configuration. The secondary actuator was designed to be controlled by any of the four electrohydraulic control channels. Each primary channel commanded one active valve to position the actuator; the second valve, in conjunction with the hydrologic failure detection network, was used for self-monitoring. The actuator standby or backup channels commanded by the backup control system consisted of three force-summed channels with electronic failure detection.

Two-stage flapper nozzle servovalves were used for the primary system active and monitor valves. During normal operation, these valves received separate commands, and the active valve positioned the actuator ram as required. The failure detection for the primary control system was provided by a hydraulic comparator network. A comparator spool was balanced between the force exerted by two springs and the output pressures from the active and monitor spools. If a pressure difference beyond a predetermined threshold existed, motion of the comparator spool dumped the supply pressure to the return line, which caused the primary engage valve to reposition and block the commands from the active servovalve. Errors that could cause the hydrologic comparator to trip were measured in terms of either single control surface deflection or commanded current. These were  $4^\circ$ ,  $4^\circ$ , and  $1.5^\circ$  for the elevator, aileron, and rudder control surfaces, respectively, or one-half the maximum valve current.

A dual pressure switch was installed in the primary hydraulic circuit of each secondary actuator to sense minimum pressure. The switch caused the primary servo system to disengage at  $4137 \text{ kN/m}^2$ , and a pressure of at least  $5516 \text{ kN/m}^2$  was required for manual reengagement. When the primary channel tripped, the pressure switch opened, which caused the engage logic to automatically energize the three solenoids in the backup control system and to transfer control to the three single-stage jet pipe servovalves (servo systems 2, 3, and 4).

The backup system servos were monitored by differential pressure transducers that were installed across the output legs of each jet pipe servovalve. Each differential pressure signal was compared with the other two differential pressure signals for each actuator. The comparison was made in the backup control electronics boxes.

The secondary actuators were modular in construction and were designed around three tandem pistons on a common shaft. The primary channel and one backup control system channel shared one of the piston networks, and the remaining pistons were controlled by the other two backup systems. Each secondary actuator was supplied by two separate hydraulic systems. Figure 9 shows the secondary actuator mechanization in the primary configuration.

The figure shows that the valve outputs of backup channels 2 and 4 were blocked by separate hydraulic engage valves and that the cylinders bypassed fluid as the ram moved. Backup channel 3 was blocked by an engage valve with a slightly different design.

The servo position loop was closed electrically for each channel in the elec-

tronics boxes. The electrical signal utilized for the servo ram position came from the quadruplex redundant LVDT in each servo actuator shaft. The stroke of all the secondary actuators was 5 centimeters, and by utilizing the necessary mechanical linkage, the desired control surface rotation was obtained for all five surfaces.

*Response characteristics.* — Ground test data were taken for each actuator with different valve combinations. The performance of each secondary actuator was a function of the engaged servovalves. The primary valves had much higher response than the valves used in the backup servo systems (systems 2, 3, 4), but because of hardware problems (ref. 1) the primary servo amplifier gain was lowered.

A typical frequency response curve of the elevator secondary actuator with the primary servovalve in control is shown in figure 10. The figure compares the flight tested servo amplifier gain, 5 milliamperes per volt, with the designed servo amplifier gain of 22 milliamperes per volt. Even though the pitch servo bandwidth flight tested was 6 hertz, the addition of a second-order filter reduced the effective servo bandwidth to 2.5 hertz. The total bandwidth of the filter, secondary actuator, and elevator power actuator was 1.5 hertz for an elevator surface amplitude of  $1^\circ$  peak to peak, normalized at 0.5 hertz.

The frequency response of the same pitch secondary actuator when controlled by the backup control system valves is shown in figure 11. Data are compared for two valve drive configurations. One data set was obtained with a single backup control system channel valve in control of the secondary actuator. The other data set was obtained with all three backup valves in control. The single backup control system channel bandwidth was 7 hertz, and the bandwidth of the three backup control system channels was 13 hertz. All three backup control system channels per airplane control axis had the same servo loop gain, which indicates that the performance increase was a result of the force summing of the secondary actuator pistons.

*Hysteresis.* — Hysteresis measurements were also taken for each secondary actuator for the various valve drive combinations. The data were obtained by driving the appropriate servovalves with a signal generator set at 0.01 hertz. For example, the hysteresis of the elevator secondary actuator for the primary channel (fig. 10) was  $0.44^\circ$ . By increasing the loop gain, this value could be reduced to  $0.13^\circ$ . The equivalent measurements for the two backup control system conditions presented in figure 11 are  $1.10^\circ$  for the single-channel drive configuration and  $0.47^\circ$  for the three-channel drive configuration.

A minor item of interest pertaining to the secondary actuators was observed during single channel operation with the backup control system. Even though the electrical commands to each paired surface, such as the aileron and elevator, were the same, the control surfaces did not track each other during large control cycles. This was caused by the component offset characteristics in the servo loop as well as by the seal friction of the respective actuator channel. A given servo system took more current to retract the ram for the left control surface than the right control surface and less current to extend the left than the right. From outside the airplane the control surfaces did not appear to track. This was most noticeable with the elevator surfaces. This condition existed with every actuator, and there was no way to adjust the offset. When additional servo systems were engaged, the condition was

minimized and the agreement between the deflections of the paired surfaces was good.

The condition was not apparent with the primary control system engaged because of the higher bandwidth servovalve and pressure gain.

### Electrical Power

The electrical power for the operation of the F-8C aircraft was supplied by the main generator power package. This unit was comprised of ac and dc brushless generators that were mounted on a common shaft, regulators for the generators, an air turbine motor, and the necessary reduction gears. Energy for the turbine was supplied by high pressure bleed air from the engine. The ac generator was rated at 12 kilovolt amperes at 115 volts and 400 hertz. The dc capacity was 68 amperes at 30 volts. An emergency power package supplied backup electrical power as well as a hydraulic pump driven from a ram air turbine. The capacity of this unit was 30 amperes of dc and 4.2 kilovolt amperes of 400-hertz power. Figure 12 shows the power distribution system of the F-8 digital fly-by-wire airplane.

The power requirements of the fly-by-wire system were determined by the characteristics of the Apollo equipment. This equipment limited the ripple, spike, and surge voltages on the nominal 28-volt bus to a maximum of 32.5 volts and a minimum of 24.5 volts, with a peak current demand of 60 amperes. These requirements, in addition to a requirement for an estimated 30 amperes for the backup control system, made it necessary to install an additional power source in the airplane. Therefore, a direct-drive, 100-ampere, 32-volt dc flight control system generator was mounted in the nose cone of the engine. The voltage regulator was set to provide 28-volt power at the primary (number 1) bus. To give the additional protection required by the Apollo equipment, zener diodes and a 55,000-microfarad capacitor were placed on the number 1 bus. Flight control system power was controlled from the cockpit through normally closed power relay contacts. A warning indicator informed the pilot of loss of generator power.

To provide the necessary redundancy, 28-volt power was divided into four separate busses by isolation diodes and circuit breakers (fig. 12). Each bus, one for the primary system and one each for the triply redundant backup control system, had a 24-volt, 11-ampere-hour nickel cadmium battery as an alternate source of power. Backup control system batteries were always on the line, and they were kept fully charged by a constant trickle charge. They could provide power for a minimum of 1 hour after the loss of the flight control system generator. For additional protection, it was made possible for the pilot to place the main dc generator on the backup control system busses with normal loads reduced. To assist the pilot in monitoring the condition of the backup control system battery, a battery capacity meter was installed in the cockpit. This device measured current flowing into or out of the battery in terms of percent of full charge. It was not intended for the number 1 battery to supply the primary system with power for more than a few minutes. Its sole purpose was to aid in the stabilization of the bus voltage and to allow operation during temporary power interrupts like those that occurred during bus switching. For the protection of the number 1 battery, a circuit was installed to remove the battery from the bus whenever voltage dropped below 20 volts.

## OPERATIONAL EXPERIENCE

The first operational experience with the F-8 digital fly-by-wire control system was acquired during the integration and checkout of control system components in an iron bird simulator (paper 2). The simulator was used to fine tune the control system to give it the necessary authority, trim rates, servo loop gains, and comparator trip levels. Before the first flight, the entire flight control system was subjected to an extensive ground test program that lasted 7 months. During this period, two major hardware changes were made. Because of the nonlinear characteristics of the Apollo hardware (ref. 1) unacceptable noise was transmitted to the secondary actuators. A second-order filter network was installed to smooth the primary system electronics. The backup control system integrators were changed to digital from analog because of drift.

### Backup Control System Flight Evaluation

Before the first flight, the backup control system was tailored to the primary channel gearing and trim rates in each airplane axis. The flight controllability of the primary control system and the backup control system was evaluated on the simulator. Since the sole purpose of the backup control system was to provide an emergency return-home capability if the primary system became inoperative, the flight testing of the backup system was minimal. The testing did insure that the backup system would provide acceptable controllability, and at least once per flight the F-8 digital fly-by-wire control system was downmoded to the backup control system to perform an inertial measurement unit alignment. This was done in level flight.

*Center stick.*— The piloting tasks used to evaluate the backup control system with the center stick paralleled those used to evaluate the primary control system in the direct mode. The evaluation maneuvers included routine flying while evaluating gross and fine control maneuvers, formation flight, and gunsight tracking. The low-speed evaluations included ground control approaches. The first flight evaluation took place at speeds between 275 and 300 knots indicated airspeed with routine flying maneuvers. The pilot comments indicated that roll response was adequate and pitch control was good at these flight conditions. The airplane also exhibited satisfactory handling qualities and control power in the landing approach. During subsequent flights, the airplane seemed sensitive in the roll axis, and in a more demanding control task, that is, formation flight, the pilot indicated that airplane roll response became too oscillatory (paper 7). He assigned the task a pilot rating of 6 on the Cooper-Harper scale (ref. 2). The lateral sensitivity problem was reduced by adding electrical deadband to the roll stick command signals. The modification yielded the roll gearing shown in figure 4(b). Even though the backup control system roll gearing was approximately the same as that in a conventional F-8C airplane, some pilots commented that the airplane rolled a little faster than they liked for a given stick displacement at 300 knots indicated airspeed. However, they felt that the roll response was not overly sensitive. A viscous damper was added to the aileron stick linkage to improve the dynamic stick characteristics for both the primary and the backup control systems.

For the first eight flights of the F-8 digital fly-by-wire airplane, a linear transducer was used in the pitch axis of the backup control system. As flight speeds increased, a longitudinal sensitivity problem was observed by the pilot in both the primary and the backup control systems. This problem was solved by reducing the slope of the curve around zero but maintaining the previous control authority. Because of the inflexibility of the design of the backup control electronics boxes, non-linear characteristics were obtained by having a stick transducer manufactured that was similar to the original but gave the desired curve shape. The pitch modification and appropriate scaling change in the backup control electronics boxes resulted in the backup control system pitch gearing presented in figure 4(a). Subsequent flight evaluations indicated that control was satisfactory in cruise as well as in the landing approach. In normal flight, the airplane's control characteristics with the backup control system were similar to those in the primary control system's direct (unaugmented) mode. For maneuvers that required large changes in pitch, however, such as gunsight tracking during windup turns, the pilots preferred the backup control system to the primary control system because of its smoother pitch response. The characteristics of the primary channel were poorer because of stick quantization (paper 6).

The trim switches for the backup control system pitch and roll axes were on the left cockpit console just forward of the throttle control. During the evaluation of the backup control system, it became apparent that the location of the trim switches was undesirable. One pilot rating was at least one number higher (poorer) because of the additional workload due to this location. Beginning with the side stick evaluation phase of the flight testing, the backup trim was activated from the conventional center stick trim switch.

*Side stick.* — The side stick was evaluated primarily by two pilots during six flights. Six other flights were flown by four pilots who were evaluating other features of the control system. Although the side stick gradients were not optimized, the side stick controller was considered to be of interest in the overall control system evaluation. Side stick evaluation tasks included formation flight, gunsight tracking, mild aerobatics, ground control approaches, landing, and takeoff. Since takeoff was considered the most uncertain phase of flight, it was performed only after side stick control was evaluated in a high pilot gain task during up and away flight. During the 12 evaluation flights, three takeoffs and seven landings utilizing the side stick controller were made.

The stick gradients selected for flight test were based upon the six-degree-of-freedom simulation results obtained with the iron bird simulator. The stick-to-surface gradients were selectable, as shown in figures 5(a) and 5(b). The wing-down gradients selected by most of the pilots were position 1 in pitch and position 3 in roll. The roll gradients were not changed during any of the flights, whereas a slight change was made in the pitch axis. The original transition, or knee, of the curve between the low and high gradients was at approximately 36 newtons, and this value was increased to approximately 57 newtons for the last three flights.

All the pilots adapted easily to the side stick controller in flight after practice on the simulator. They all commented on the sensitivity of the pitch axis, particularly in high pilot gain tasks like formation flight. The center stick was also somewhat sensitive, but the excursions were lower in amplitude. Some of the pilots



tended to fly both pitch and roll with a pulsing type of input. Most pilots tended to hold a nose-up stick force during the various maneuvers. The value they used was approximately 23 newtons, which was outside the stick deadband. One of the six pilots noted arm fatigue after a flight in which he evaluated side stick control. Several pilots rated the formation flight control task 3 to 5.

As discussed in paper 7, gunsight tracking was typified by good to excellent control over the lateral-directional axis and continuous pitch oscillations caused by pitch commands that were too abrupt. Crosstalk was absent in the tracking task. A comparison between a side stick-controlled and a center stick-controlled tracking run showed a higher frequency output from the force side stick, indicating a higher pilot workload.

The wing-up stick force gradients were evaluated in the power approach configuration for pitch out maneuvers and ground control approach patterns. Many of the approaches were flown in light turbulence, which seemed to have little adverse effect on control. Pitch and roll control was adequate, and pilot ratings ranged from 2 to 4 for the landing approach task.

### Synchronization Performance

An important design requirement for a backup control system is that it track the primary system closely to minimize the switching transients. Therefore, synchronization networks were used to keep the systems synchronized. During every flight, the primary system was downmoded to the backup control system at least once to align the inertial measurement unit in level flight.

Thus, downmoding to the backup control system was checked approximately 40 times. The surface transients were always less than  $1^\circ$ . The transients observed during these downmodes were caused primarily by the differences in null between the primary and the three backup servovalves of each secondary actuator. Overall, the system's static performance was good.

Simulation studies on the iron bird simulator showed that the synchronization network bandwidth of 2.5 hertz provided satisfactory backup control system tracking of the primary system for all except abrupt stick commands. The simulator studies also indicated that the synchronization/trim network characteristics could produce a large out-of-trim condition during a dynamic downmode if stick or pedal commands were being applied. The corrective action was to trim out the stick or pedal signal present at the time of the downmode.

### Trim

The backup control system was mechanized with a digital integrator for trimming the backup control system and for synchronizing the backup control system with the engaged primary system. Since the control systems had to be synchronized over the full authority of the control surfaces, the integrator had to be scaled for full control authority. This resulted in an integrator resolution of  $0.18^\circ$ ,  $0.30^\circ$ , and  $0.20^\circ$  for

elevator, aileron, and rudder, respectively. Trimming a control surface became a stepping operation and was not precise.

### Hydraulics

The conventional F-8C hydraulic systems were not changed except for the addition of the F-8 digital fly-by-wire secondary actuators. Two hydraulic pumps each delivered a maximum of 45 liters per minute at a nominal pressure of 20,684 kN/m<sup>2</sup>. This capacity was marginal during two operations. At idle power, the hydraulic flow was inadequate to support preflight self-tests. A power setting of 80 percent proved to be satisfactory and was used for airplane ground checks. The self-tests were designed to operate in all three axes or one axis at a time. The latter procedure was used most often, although the three-axis tests were completed in approximately 4 minutes. During landing at idle power, high control surface activity caused the hydraulic pressure to drop, which caused the secondary actuator pressure switches to downmode the F-8 digital fly-by-wire system from the primary to the backup control system. This occurred during two landing rollouts, but no control system transients were observed by the pilot.

### CONTROL SYSTEM RELIABILITY

The primary and backup control systems operated approximately 2500 hours during the fly-by-wire program, including both aircraft and iron bird operation, without any major problems. Six evaluation pilots flew the F-8 digital fly-by-wire airplane 42 times for a total flight time of 58 hours. Because of its length, the program was not expected to establish a level of confidence in fly-by-wire control systems, but it did constitute a first step toward developing such confidence. From the first flight, the airplane was flown with a control system that had no mechanical backup or reversion capability. During the evaluation flights, there were no system failures that could be attributed to the fly-by-wire aspect of the digital flight control system. There were no electronic failures in flight in either the digital primary system or the backup control system. There was one hydraulic line failure that reduced the total system redundancy level from four channels to two channels, but flight was no more critical than it would have been if a similar failure had occurred in a standard F-8C airplane. This is discussed in more detail below.

In addition to the reliability of the total system, it is important to discuss the reliability of the elements of the system. Table 1 summarizes the discrepancies that occurred in the F-8 digital fly-by-wire control system. The table includes the discrepancies experienced with the iron bird simulator as well as those experienced with the F-8 digital fly-by-wire airplane. Discrepancies observed during ground operation, preflight testing, and in flight are listed by major system component. A discrepancy was any system operation that appeared to be abnormal. Some were minor transient effects that did not affect the system's performance or reliability. The number of discrepancies that required a repair or replacement action is indicated. Even if no repair was required, extensive tests were made to insure that the component in question performed as designed.

The discrepancies listed for the computer and related hardware, which are discussed in paper 6, are listed here to present an overview of the operational problems encountered during the program. A coolant system designed specifically for the Apollo system used on the F-8 digital fly-by-wire airplane caused one flight to be canceled before takeoff and one flight to be terminated early. The coolant system problem was attributed to lines that were frozen and did not permit the coolant to flow through the cold plates. When this occurred in flight, the coolant system was being monitored and the flight was terminated before it affected the control system. The pilot continued to fly on the digital primary system, and four channel redundancy was retained through landing. This problem was unique to the Apollo equipment and therefore would not be expected in production fly-by-wire systems.

Three power turn-on problems were observed, two with the backup electronics and one with the primary electronics. On one occasion, measurements indicated that the voltage supply for the primary electronics was not present. Recycling the power switch brought the power supply on line, and during subsequent testing the problem did not reappear. Laboratory testing did not reveal the cause of the problem, but a similar power turn-on indication was obtained by grounding either the plus or minus power supply.

Six failures due to open buffer resistors were recorded in the primary and backup electronics early in the program. It was discovered that the resistance wire in these resistors was affected by chemical or electrolytic corrosion. All the buffer resistors were replaced by a different type of resistor, and no other problems of this type were encountered. The other component failures listed were caused by an intermittently functioning capacitor, a failed zener diode, and an open transistor. None of these occurred in flight, and all were detected through normal testing procedures. During the flight program there were 12 backup electronic comparator tripouts, but the redundancy level of the total system was not affected. Ground checkout indicated that there were no failed components.

The secondary actuator discrepancies consisted of component failures, problems related to differential pressure, and differential pressure comparator tripouts. With 25 servovalves, 20 engage solenoids, and 20 differential pressure transducers in the airplane, occasional problems were expected. The servovalve was the only secondary actuator component to fail. Three such failures occurred in the aircraft system. They were detected during ground tests and repaired. If such a failure had occurred in flight it would have caused the loss of one of the four actuator channels.

As the table shows, the largest number of discrepancies occurred in the secondary actuator differential pressure network. Four aborted takeoffs were charged against the differential pressure network, as well as four in-flight and 26 preflight differential pressure comparator tripouts. Most of these discrepancies were classified as nuisance tripouts and occurred during control cycles whenever the primary system was engaged. All comparator tripouts were resettable by the pilot, and the total system's redundancy was not affected. Generally speaking, most of the differential pressure problems experienced were caused by a tracking error between the various differential pressure signals, which caused the servo comparators to trip. This frequently occurred at the maximum travel of the actuator, where the differential pressure signals were the highest. These nuisance tripouts were caused by a

combination of the various components' tolerances and valve nulls, and were predictable for certain stick motions. The problem could be resolved by adding nulling capability to the servo loop to balance the various differential pressure signals.

Another problem associated with the differential pressure monitoring system was the inability to detect some of the open failures. Unless the ram was stationary, it was difficult to develop the differential pressure necessary to disengage the faulty servo channel. As a result, a latent channel failure could occur in flight in the backup control system and not be indicated to the pilot. However, no such failures occurred during the program.

Six discrepancies were attributed to system wiring and aircraft power distribution. Four involved, respectively, a pin that was pushed back in a connector, a short-circuited cable clamp, a defective latching relay, and a faulty battery capacity meter. The faulty items were identified and repaired during the regular airplane preflight. Two flights were aborted because of aircraft power problems. One was due to a checklist error that allowed the flight control system generator to remain off, causing a low-voltage shutdown of the computer, and the other was due to a main generator failure. All those discrepancies were considered to be typical airplane operating problems and not unique to fly-by-wire control systems.

Four discrepancies that affected or would have affected the digital fly-by-wire system occurred in the aircraft hydraulics systems, and all required repair action. Hydraulic leaks that caused two flights to be cancelled were detected in the secondary actuators. During one flight, hydraulic oil was seen streaming along the outside of the airplane, and as a precautionary measure the flight was terminated and the airplane returned for a normal landing. During another flight, a hydraulic line ruptured, causing a loss of hydraulic pressure to backup channels 2 and 4. The hydraulic line was part of the basic F-8C hydraulic system that was not modified for the program. The loss of hydraulic pressure was detected by the pilot from the conventional F-8C hydraulic pressure gages and warning lights. The pilot terminated the flight and landed the airplane with the primary control system. Hydraulic line failures are rare but serious for flight control systems that depend on irreversible hydraulic actuators, such as those being used in all high-performance fighter and bomber aircraft and many new transport aircraft. Protection against hydraulic system failure is provided by using dual or triple hydraulic systems. Experience with aircraft that use irreversible actuators has shown the protection provided by this practice to be adequate.

As the table shows, similar operating problems were experienced with the iron bird control system. All the simulation systems were flight qualified and could be flown on the airplane except the mechanizations of the primary and backup electronics, which were not maintained with flight system quality control. The experience obtained during the almost 2500 hours of operating time on the iron bird and the F-8 digital fly-by-wire airplane is indicative of what could be expected of a similar period on the aircraft system.

Although many component discrepancies occurred during the program, they were detected by the monitoring system and testing procedures, and the reliability of the total system was maintained throughout the program.

## CONCLUDING REMARKS

A digital fly-by-wire control system with a triplex analog backup control system was flight tested in an F-8C airplane. Six pilots logged 58 flight hours during 42 flights. The backup control system operated well in conjunction with the digital primary system and provided satisfactory handling qualities throughout the flight envelope evaluated. This experience showed that a dissimilar control system can be made to synchronize with the primary flight control system and provide satisfactory control during normal flight maneuvers.

A limited flight test program was flown to evaluate airplane handling qualities with a force side stick controller through the backup control system. Even though side stick force gradients were not optimized, the control of the airplane in a variety of control tasks, including takeoff, landing, and formation flight, was satisfactory.

The operational reliability of the digital fly-by-wire system, both primary and backup, was excellent. There were no downmodes from the digital primary control system to the backup control system in flight due to real or apparent system failures. Several component discrepancies occurred within the redundant system, but they did not affect the reliability of the total system. Most of the discrepancies were in the secondary actuator differential pressure network and were nuisance tripouts (capable of being reset) within the backup control system during large control inputs to the digital primary control system.

## REFERENCES

1. Deets, D. A.; and Szalai, K. J.: Design and Flight Experience With a Digital Fly-By-Wire Control System Using Apollo Guidance System Hardware on an F-8 Aircraft. AIAA Paper No. 72-881, 1972.
2. Cooper, George E.; and Harper, Robert P., Jr.: The Use of Pilot Rating in the Evaluation of Aircraft Handling Qualities. NASA TN D-5153, 1969.

TABLE 1. - F-8 DIGITAL FLY-BY-WIRE CONTROL SYSTEM DISCREPANCIES

	Iron bird simulator		F-8 digital fly-by-wire airplane			
	Total discrepancies	Repair action required	Total discrepancies	Repair action required	Preflight	In flight
Primary system						
Computer (program characteristics)	4	0	6	0	0	0
Related hardware - mode panel, stick transducer, . pallet signal boxes, inertial measurement unit	1	1	4	3	0	0
Coolant system	2	0	2	2	a <sub>1</sub>	a <sub>1</sub>
Primary control electronics						
Power	0	0	1	0	0	0
Components	0	0	2	2	0	0
Backup control electronics						
Power	0	0	2	0	0	0
Components	0	0	7	7	a <sub>1</sub>	0
Electronic comparator (tripouts)	0	0	12	0	0	12
Secondary actuators						
Components	6	5	3	3	0	0
Differential pressure related	2	0	5	4	a <sub>4</sub>	0
Differential pressure comparator (tripouts)	0	0	30	0	26	4
Aircraft and system wiring						
Aircraft and system wiring	0	0	2	2	0	0
Aircraft power						
Aircraft power	0	0	4	3	a <sub>2</sub>	0
Aircraft hydraulics						
Aircraft hydraulics	0	0	4	4	a <sub>2</sub>	a, b <sub>2</sub>

<sup>a</sup> Flight terminated.

<sup>b</sup> System redundancy reduced to two channels on one flight.

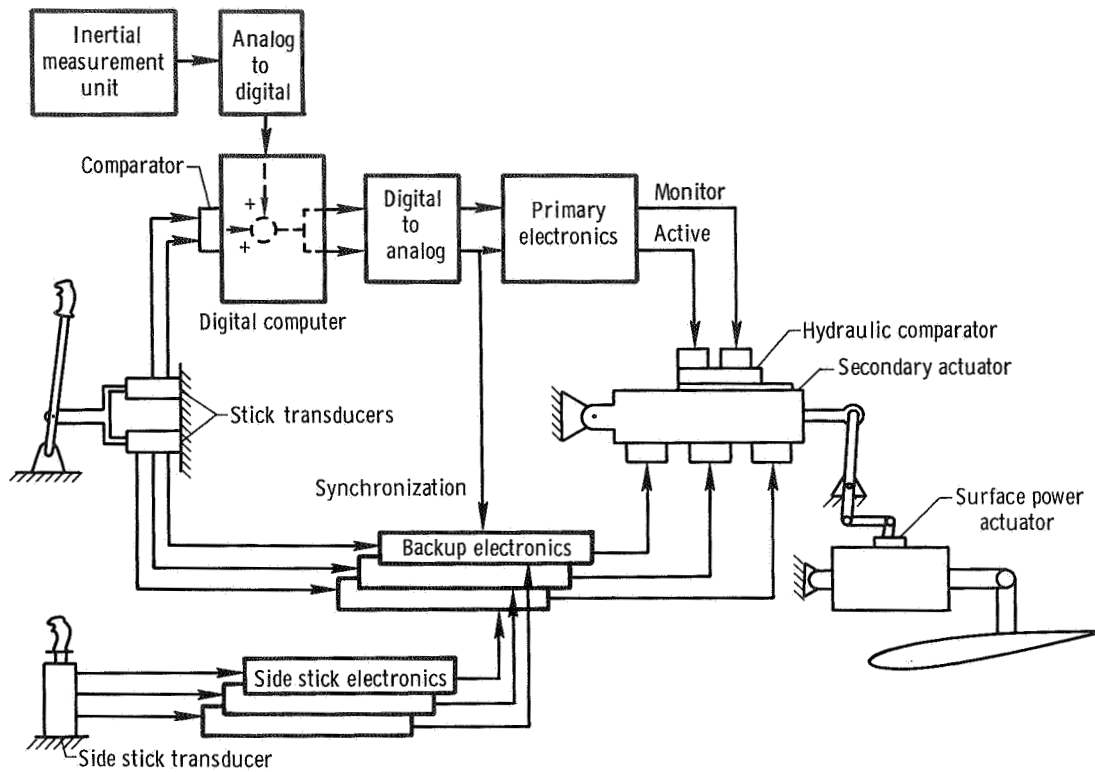

Figure 1. F-8 digital fly-by-wire control system .

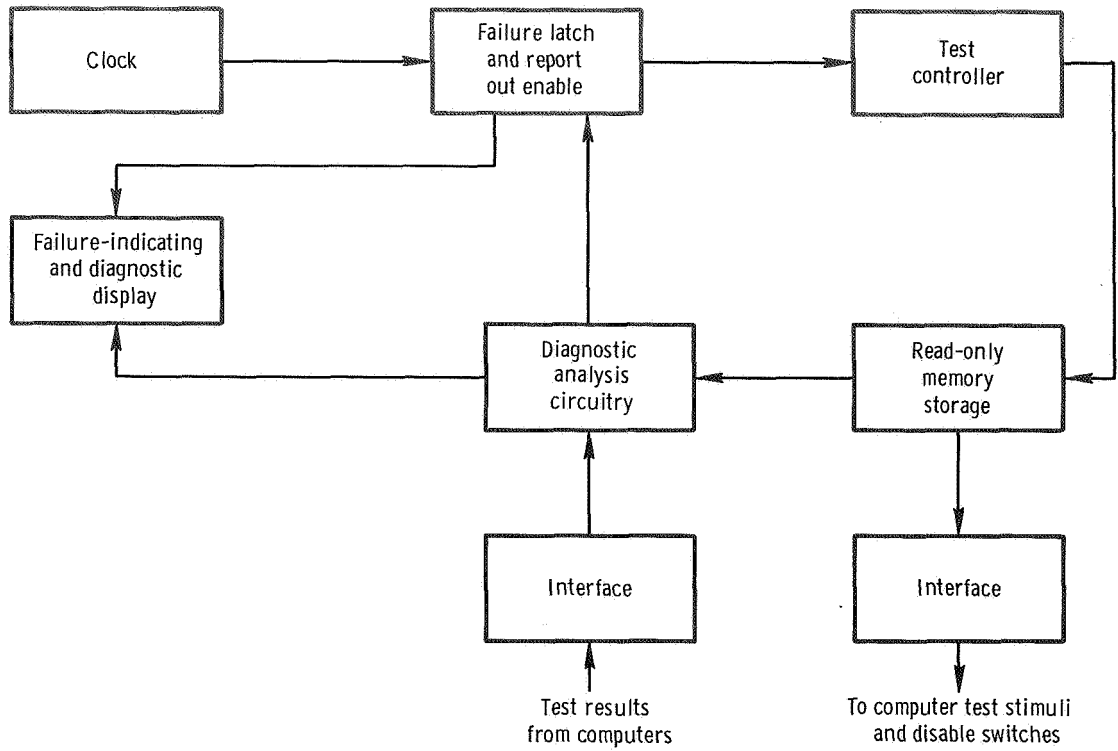

Figure 2. Self-test unit.

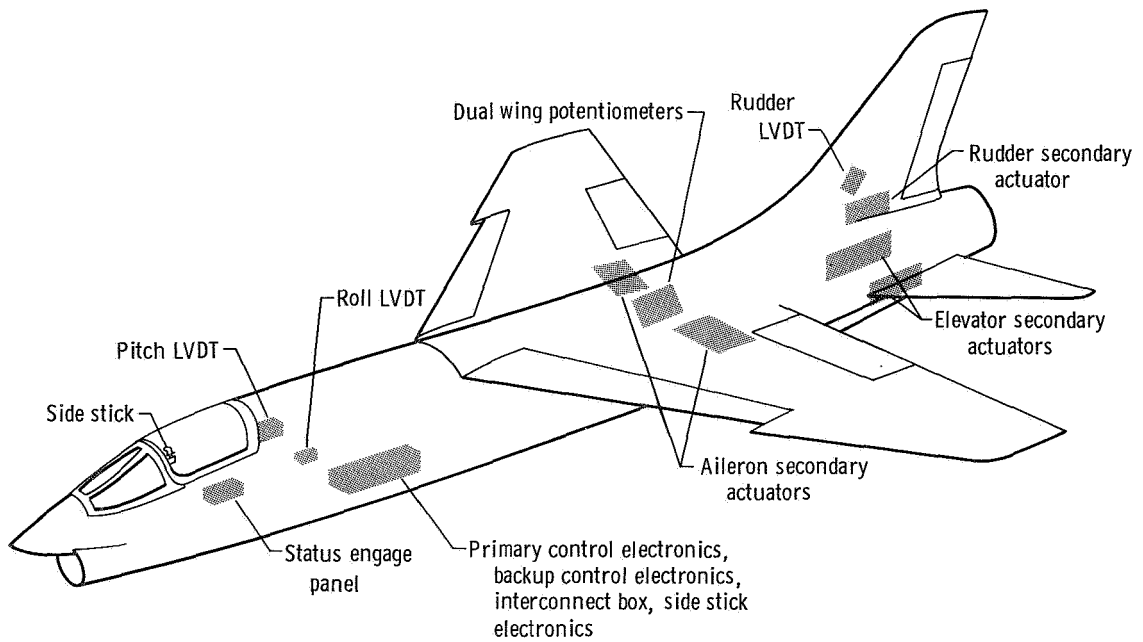
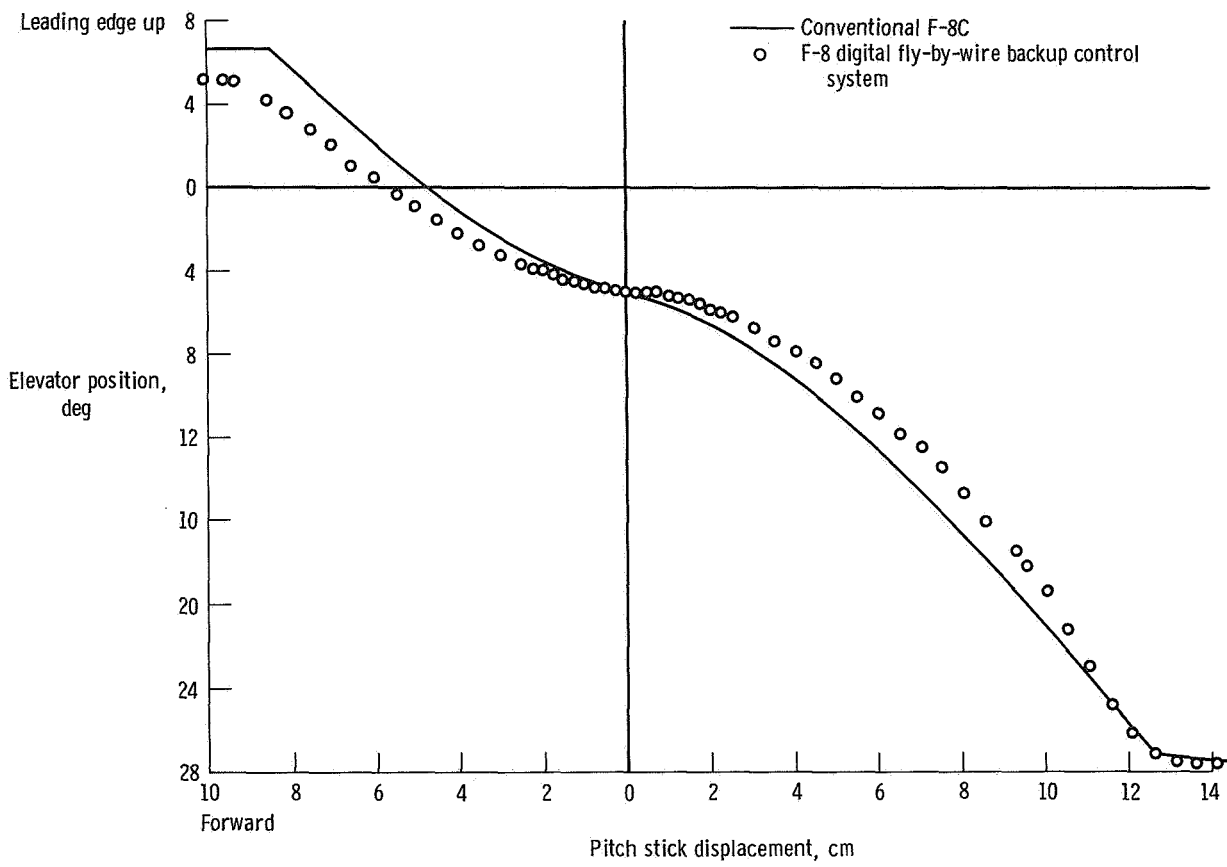

Figure 3. Components of F-8 digital fly-by-wire control system.





(a) Pitch.

Figure 4. Comparison of conventional F-8C and F-8 digital fly-by-wire backup control system pitch, roll, and yaw axis gearing.

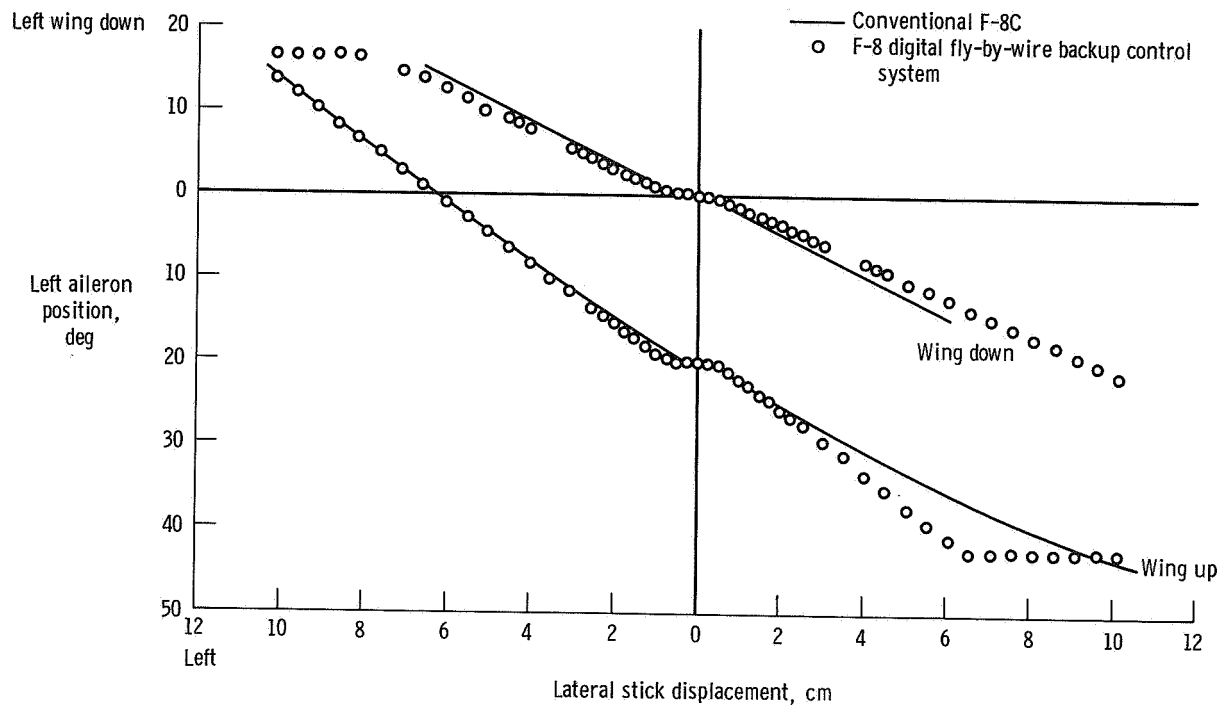

(b) Roll.

Figure 4. Continued.

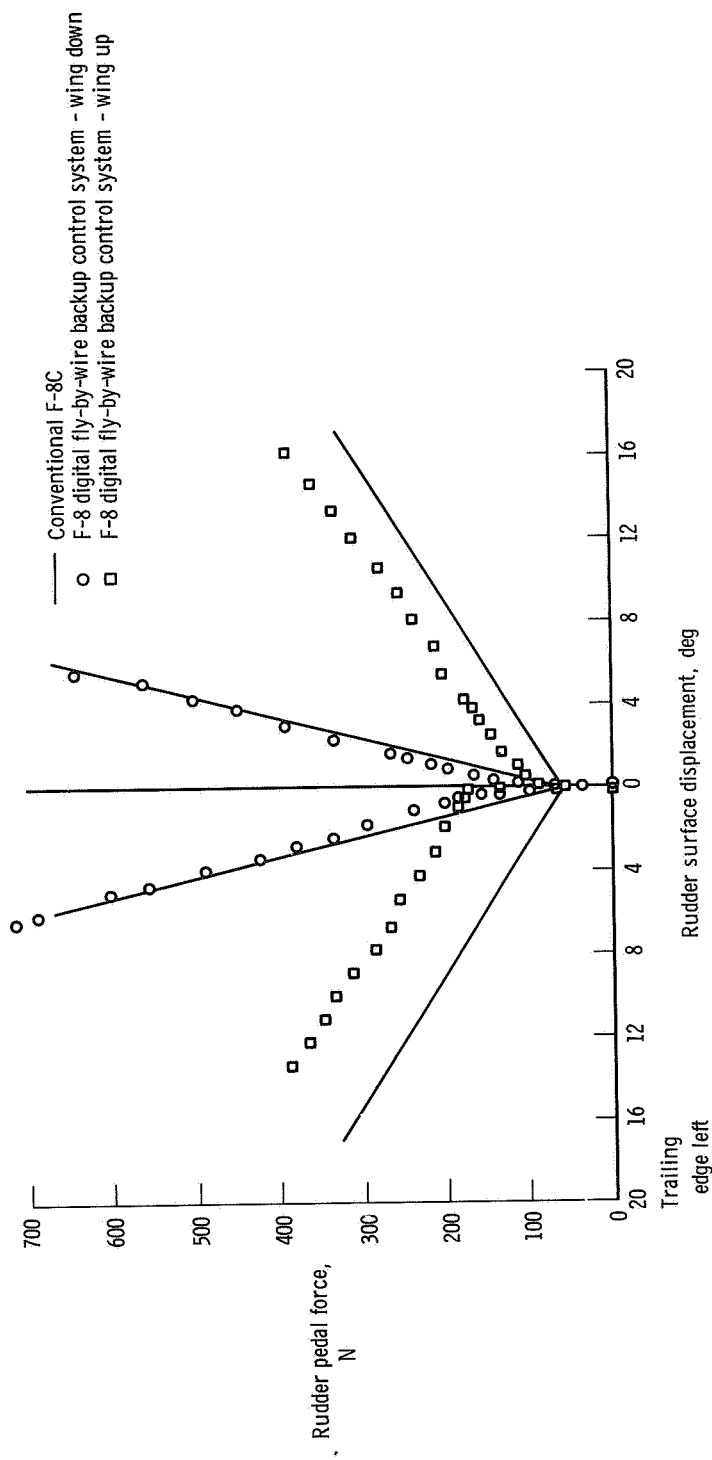

(c) Yaw .

Figure 4. Concluded .

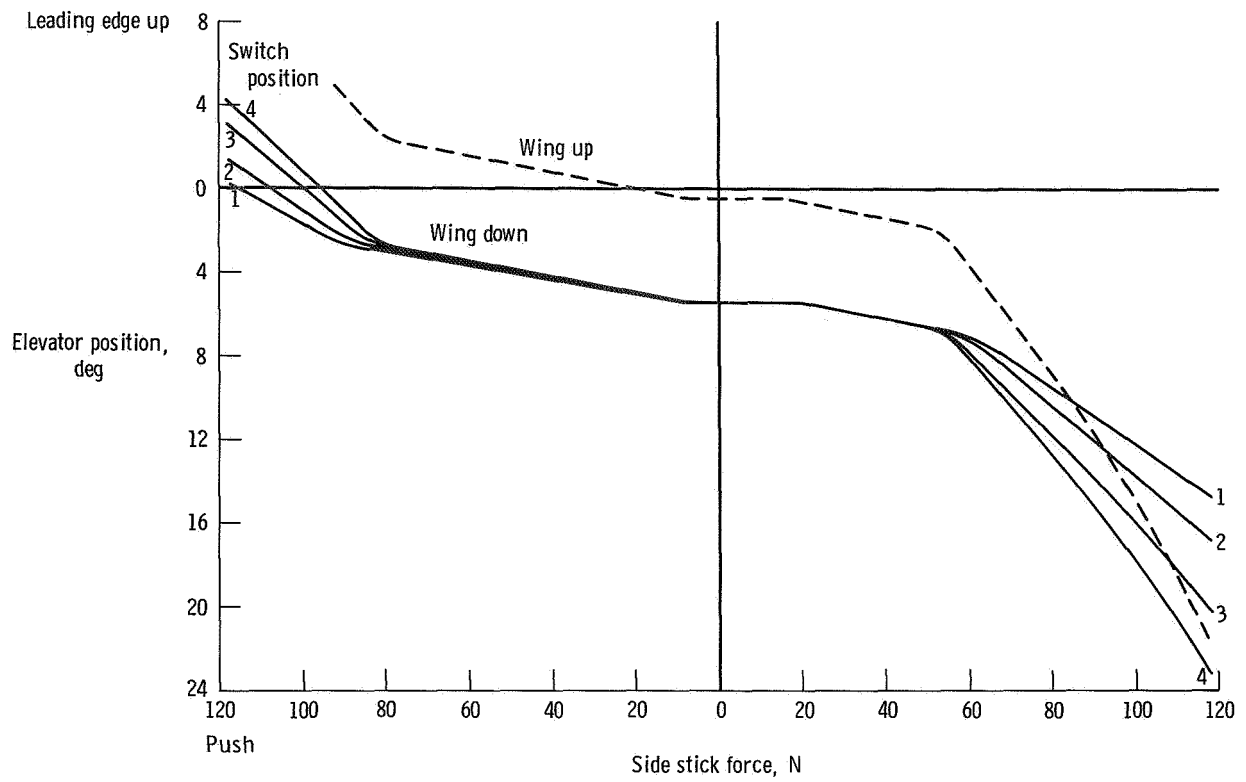

(a) Pitch.

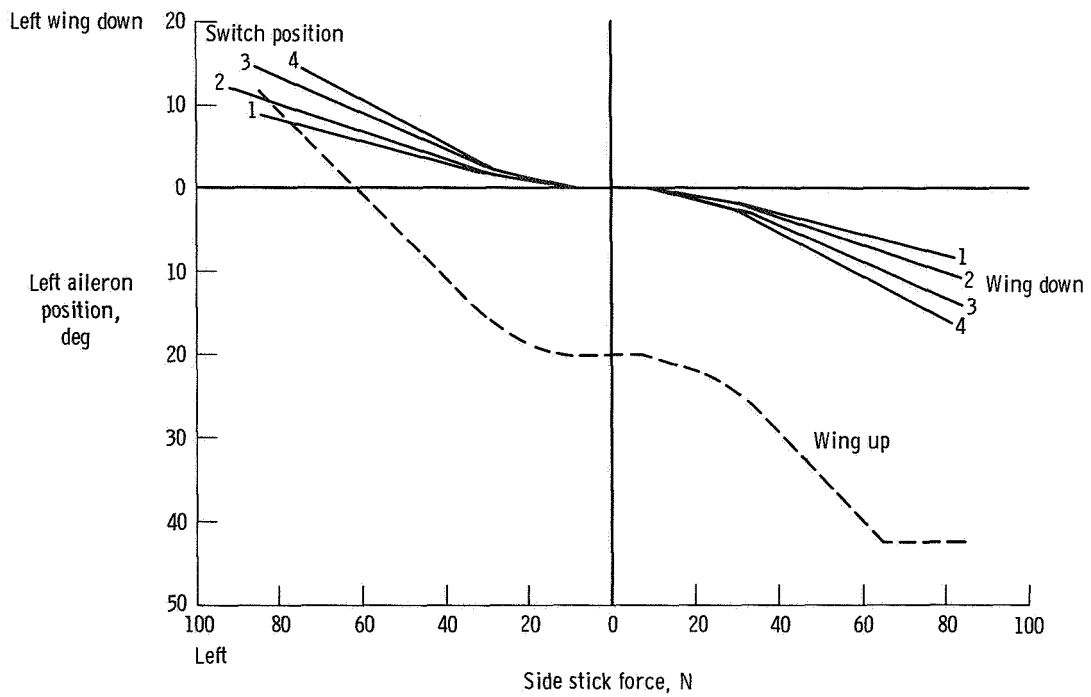

(b) Roll.

Figure 5. Side stick gearing in pitch and roll axes.

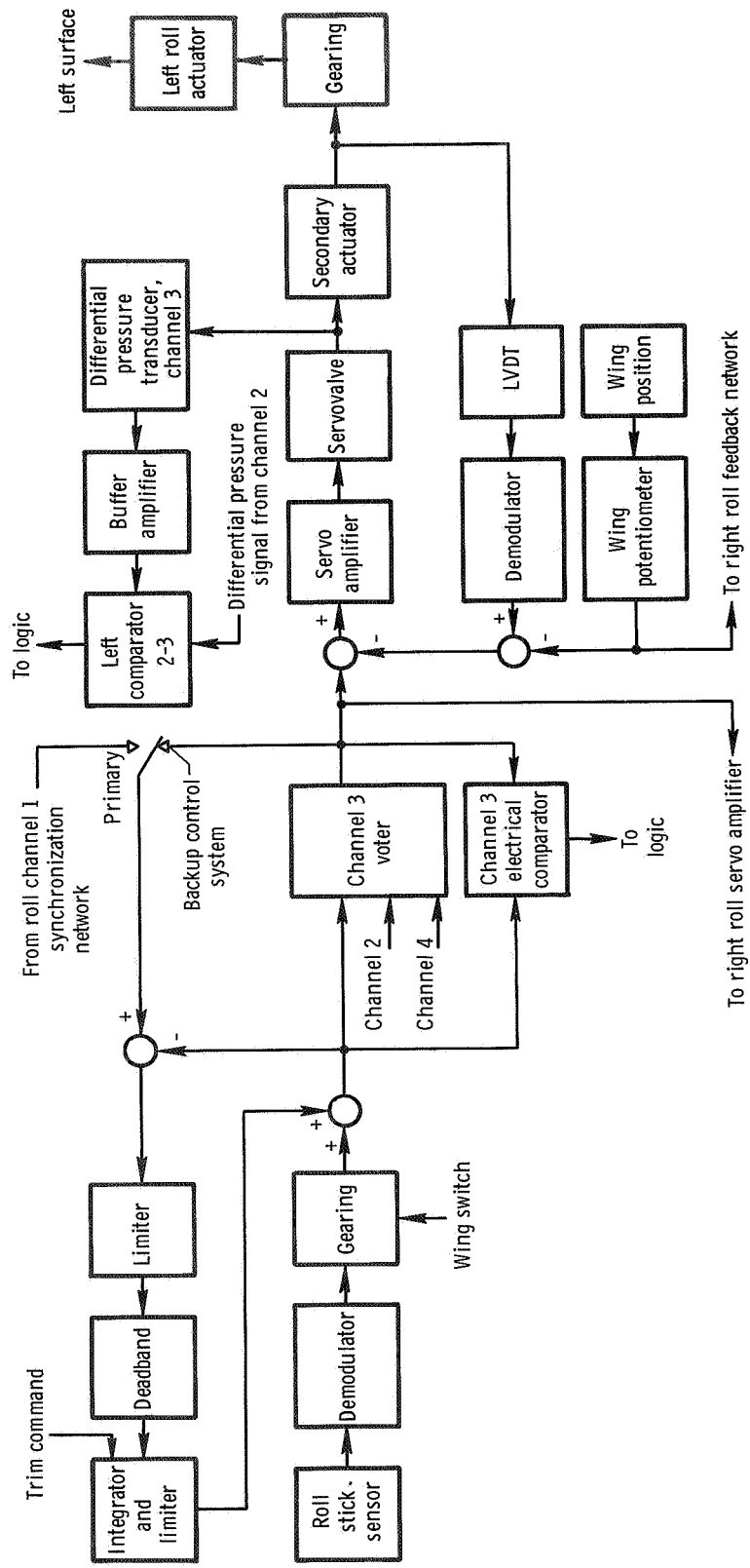

Figure 6. Roll backup control system channel 3.

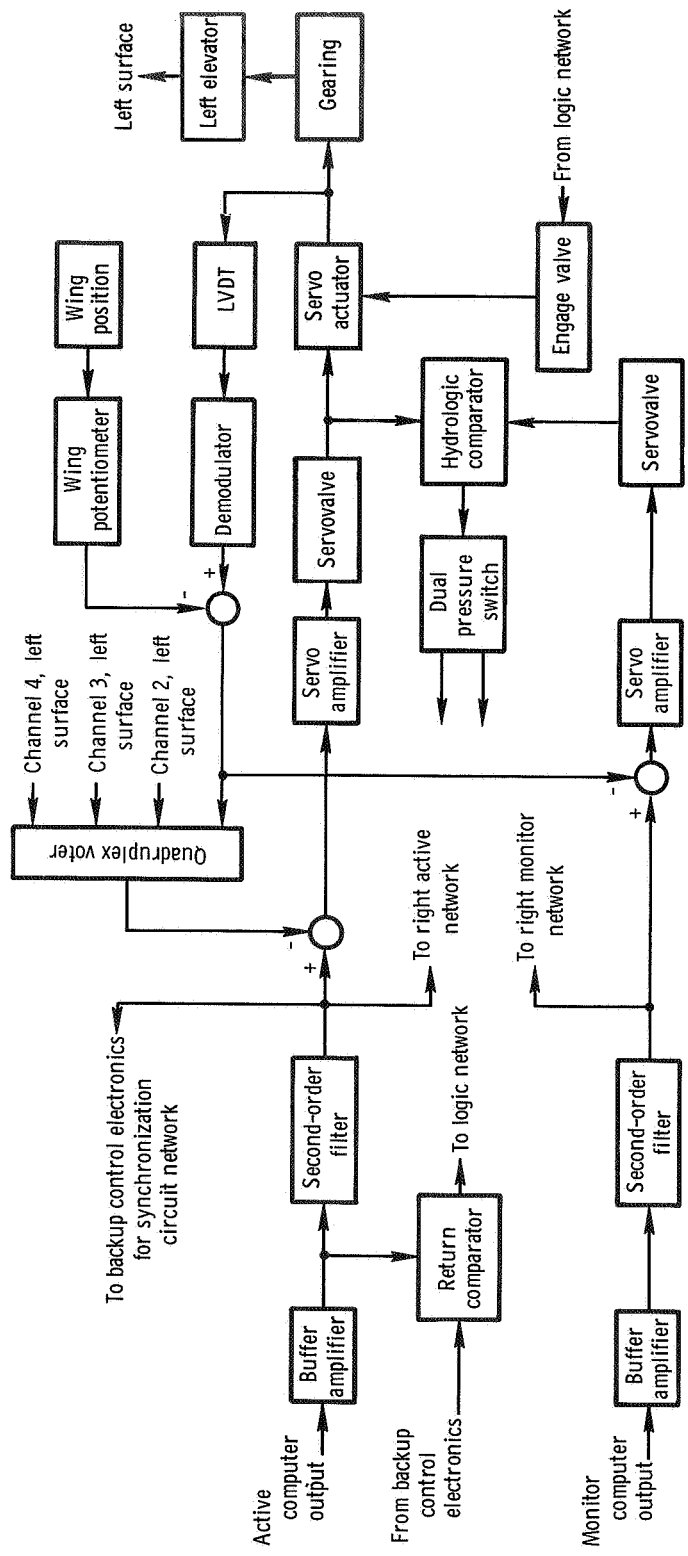

Figure 7. Typical primary control system channel.

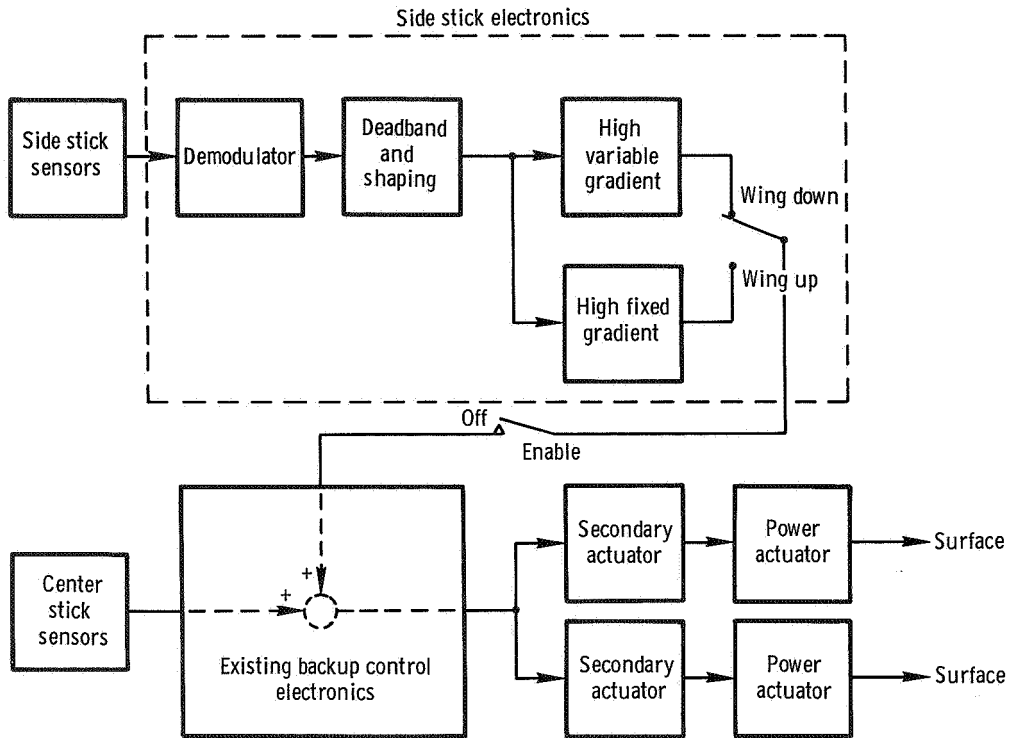

Figure 8. Side stick block diagram.

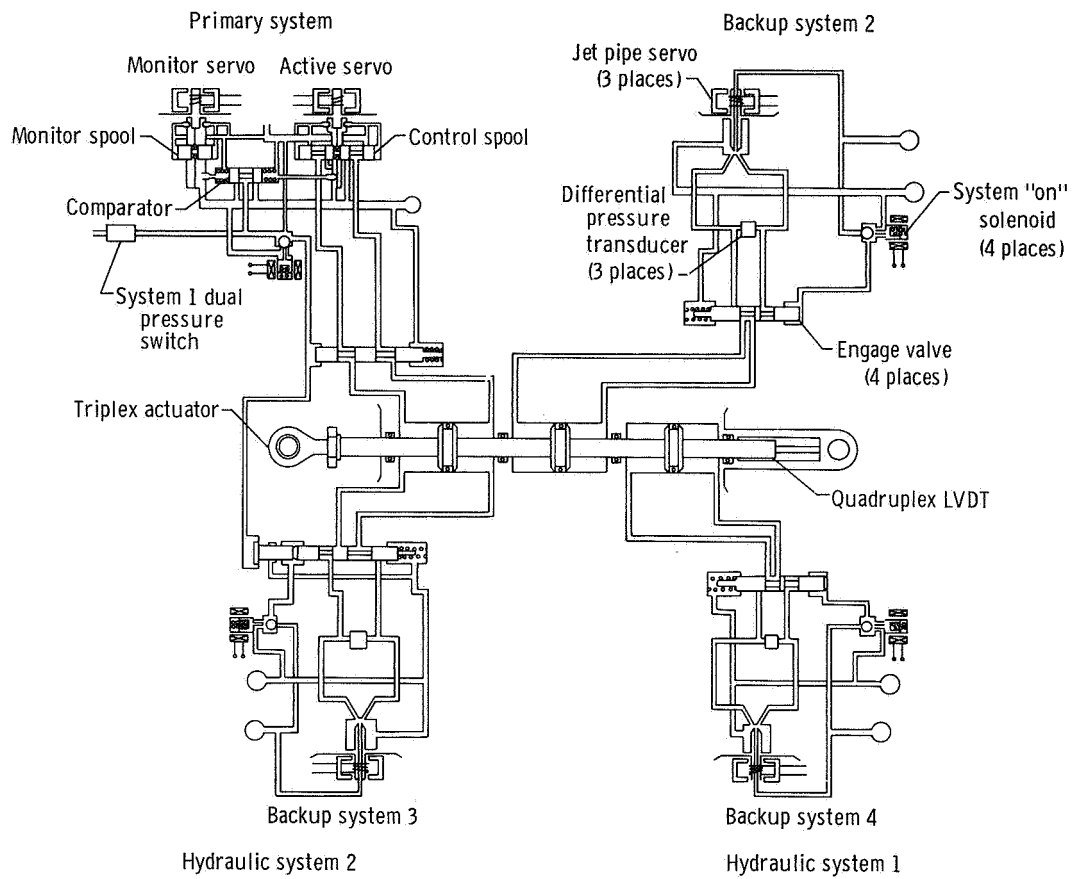

Figure 9. Hydraulics of secondary actuator with primary channel in control and channels 2, 3, and 4 in standby configuration.



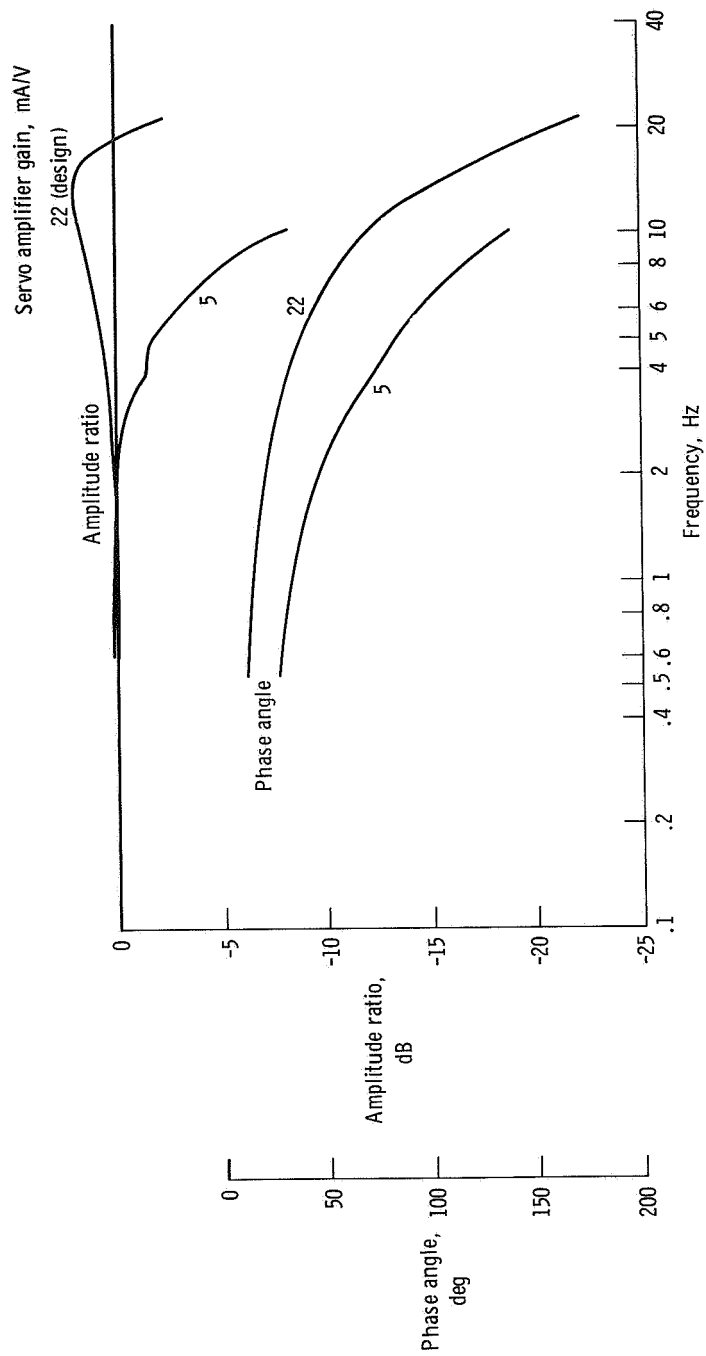

Figure 10. Comparison of elevator secondary actuator frequency response controlled with off-design and design gains of primary servo amplifier.

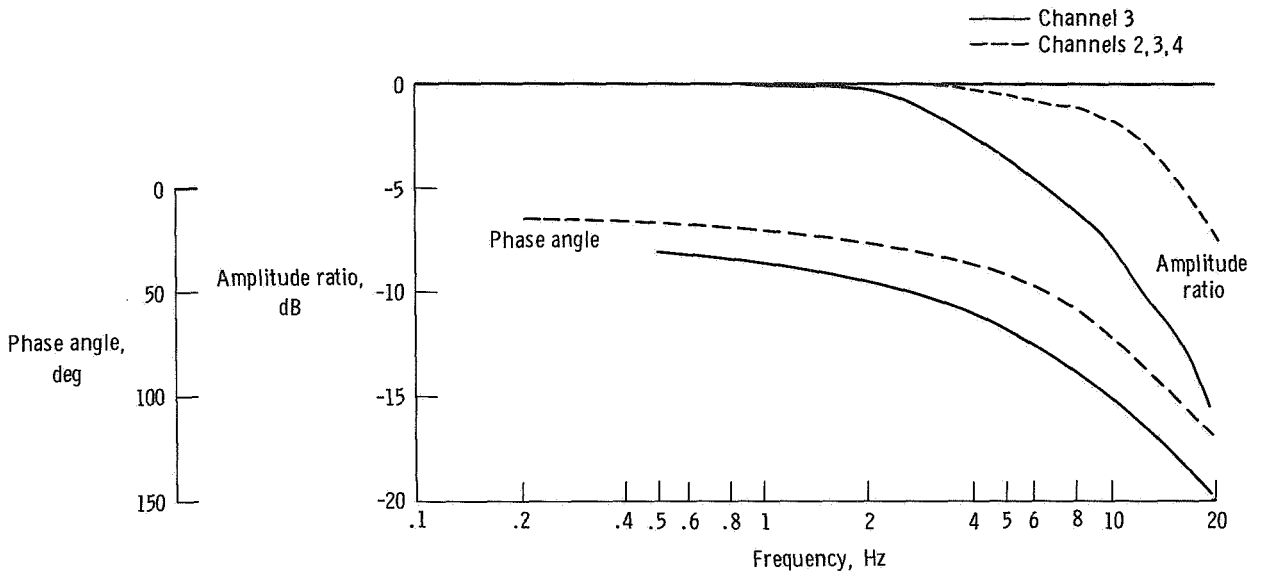

Figure 11. Comparison of elevator secondary actuator frequency response controlled with backup control system valves.

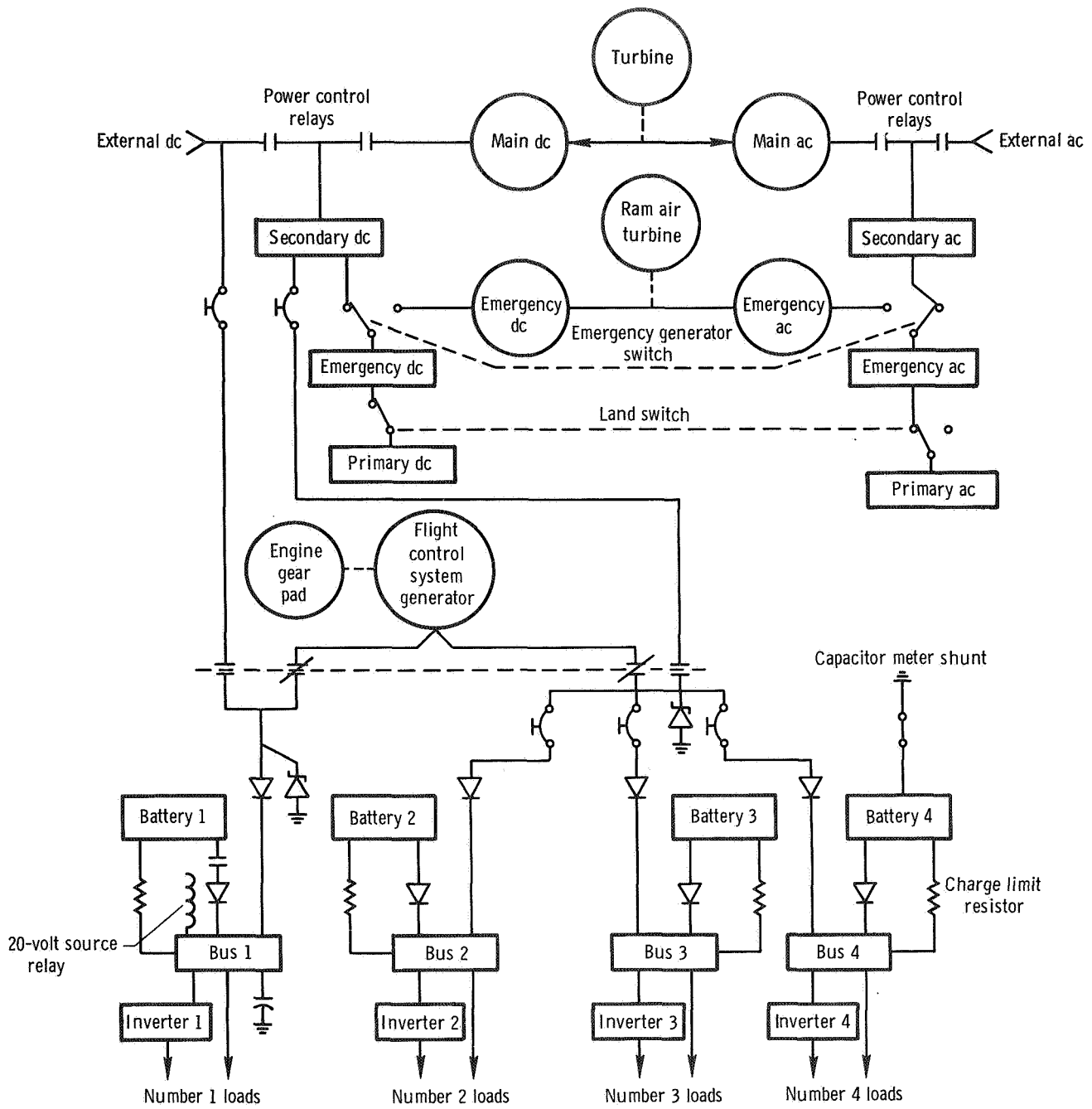

Figure 12. Simplified diagram of F-8 DFBW power distribution system.



## 4. THE EFFECTS OF LIGHTNING ON DIGITAL FLIGHT CONTROL SYSTEMS

J. Anderson Plumer  
General Electric Co.  
Corporate Research and Development

Wilbert A. Malloy  
Delco Electronics Division  
General Motors Corp.

and

James B. Craft  
NASA Flight Research Center

### SUMMARY

Present practices in lightning protection of aircraft deal primarily with the DIRECT EFFECTS of lightning, such as structural damage and ignition of fuel vapors. There is increasing evidence of troublesome electromagnetic effects, however, in aircraft employing solid-state microelectronics in critical navigation, instrumentation and control functions. The potential impact of these INDIRECT EFFECTS on critical systems such as Digital Fly-by-Wire (DFBW) flight controls has been studied by several recent research programs, including an experimental study of lightning-induced voltages in the NASA F8 DFBW airplane. The results indicate a need for positive steps to be taken during the design of future fly-by-wire systems to minimize the possibility of hazardous effects from lightning.

### INTRODUCTION

Present practices in lightning protection of aircraft deal predominantly with what may be called the DIRECT EFFECTS of lightning, including burning, blasting and physical deformation of skins and structural elements. Existing lightning

protection specifications, such as MIL-B-5087B, (Bonding, Electrical, and Lightning Protection, for Aerospace Systems) concentrate on electrical bonding and its function in minimizing these effects. Other criteria such as FAA Advisory Circular No. AC 25-3A, provide guidance for protection against lightning ignition of flammable fuel-air mixtures. Concern with these effects has been necessary since safety of flight in a lightning environment has heretofore primarily depended upon protection against fuel ignition and structural damage that can be produced by lightning. There is increasing evidence of troublesome electromagnetic effects due to lightning, however, as a result of transient surge voltages induced in aircraft electrical wiring. These voltages have caused both permanent damage and temporary malfunction of equipment.

Earlier vacuum tube electronics were inherently less vulnerable to lightning-induced voltage surges; however, the newer generations of modern, solid state microcircuitry are increasingly more vulnerable to upset or damage from such effects. Because these are electromagnetically induced effects, they are often referred to as the INDIRECT EFFECTS of lightning. Recently, these effects have been receiving additional attention since the flight safety of modern aircraft is increasingly dependent on reliable operation of critical electronic systems. At present there are no standards or specifications applicable to the INDIRECT EFFECTS of lightning.

With the advent of fly-by-wire systems, particularly those with digital computer and control electronics, the indirect effects of lightning very clearly have the potential of presenting a hazard to safety of flight. This hazard may be particularly acute for digital systems. While most practical digital fly-by-wire systems would include multiple redundant control circuits it is possible to conceive of a situation in which the high level electromagnetic interference produced by lightning could interfere with all channels of a fly-by-wire system at once, raising the possibility that there may in fact be no real redundancy with respect to lightning effects.

The NASA Flight Research Center has developed and is presently demonstrating a digital fly-by-wire (DFBW) flight control system in an F8 aircraft. Recognizing the possibility of this hazard, a program was implemented with General Electric to evaluate the possible electromagnetic effects of lightning on this flight control system and obtain data for use in minimizing these effects in future generations of fly-by-wire aircraft. The F8 DFBW system was not designed to withstand lightning strike effects. Therefore, the opportunity existed to experimentally determine the severity of effects in this unprotected system, thus providing test data upon which to base design guidelines for protection of future systems.

## SYMBOLS

A/C	Aircraft
AGC	Apollo Guidance Computer (DFCS computer)
BCS	Backup Control System
DFCS	Digital Flight Control System
DFBW	Digital Fly by Wire
IR	Structural ohmic resistive voltages
$i_L$	Lightning current

## TEST AND MEASUREMENT TECHNIQUE

A recently developed simulated lightning test and measurement system known as the TRANSIENT ANALYSIS technique offers a means of investigating the electromagnetic effects of lightning without hazard to the aircraft being tested. This technique, the development of which was sponsored by the Aerospace Safety Research and Data Institute of NASA-Lewis Research Center (Ref. 1), consists of injecting current surges into an aircraft, of the same waveshape as those produced by lightning but of greatly reduced amplitude. The responses of the aircraft's electrical circuits to these current surges can be measured and then extrapolated to correspond with full lightning stroke amplitudes to determine if they present a hazard to the equipment under test. During the development of this technique, tests were made to show that the response of an aircraft electrical system was linear with lightning current amplitude and that this extrapolation was valid. The transient analysis technique was utilized in the study of the NASA F8 DFBW aircraft in this program. A photograph of the aircraft and test setup is shown in Figure 1.

The test circuit is shown on Figure 2(a). The airframe is connected to ground at the point nearest the terminals of the circuit being measured via a 36 inch wide, 3 mil aluminum foil. This was attached to the instrument table and the hangar ground about 20 feet away. Use of the aluminum foil provides a very low impedance between the airframe and instrument table. The instrument cable was placed along this foil so that no air gap existed between it and the foil. As shown on Figure 2(b), the lightning current circuit is grounded once and only via this airframe ground foil. Consequently, no simulated lightning

current could flow off of the airframe along this path or the instrument cable shield and get back to the transient analyzer.

Most of the tests were made with a unidirectional simulated lightning stroke current rising to its crest in 2.75 microseconds and decaying to half value after 60 microseconds. This waveform is representative of natural lightning stroke waveforms and is similar to the waveform specified for indirect effects testing of the Space Shuttle. Its crest amplitude was set at 300 amperes to minimize the possibility of interference or damage to any of the electronic systems or components aboard the aircraft. Natural lightning strokes exceed 200,000 amperes about 1% of the time and average about 30,000 amperes in amplitude. Therefore, voltages induced by this waveform must be extrapolated upward by a factor of 100 to correspond with an average lightning stroke or 670 to correspond with a severe 200 kA stroke. The test current waveform is shown on Figure 2a.

It will be noted that damped oscillations appear on the test current wavefront. These are believed to be the result of traveling wave reflections in the transmission line formed by the aircraft and return conductor beneath it. Measurements were made of the current entering as well as leaving the aircraft, verifying that the superimposed oscillations flowed through the aircraft along with the fundamental current waveform. The extent to which oscillations or "jagged edges" occur in natural lightning current wavefronts is not well known, although available oscillographic data (Ref. 2) does show evidence of such occurrences in some strokes.

Induced voltages were measured by a Tektronix Type 545 oscilloscope with a Tektronix Type G differential pre-amplifier. The differential measurement system previously developed for this technique and described in Ref. 1 was utilized. One channel of the measurement circuit was normally connected to the circuit conductor being measured, and the other channel was connected to the DFCS ground, airframe ground or circuit low side, as required for the measurement being made. The pre-amplifier subtracted the signal on the second channel from that on the first so that common-mode errors induced in the instrument cable would not appear in the measurement.

Measurements were made with the DFBW system powered with batteries and operating in the primary mode. Access to most circuits was made with break-out boxes at important interfaces in order to maintain circuit continuity, although some measurements were made at opened interfaces to obtain measurements of open-circuit voltages at cable ends.



## DESCRIPTION OF DFBW SYSTEM

The F8 digital fly-by-wire flight control system components are shown in Figure 3. A single digital primary channel and triple redundant electrical analog backup channels replaced the F8 mechanical control system. The primary and backup channels all provide three-axis control of the airplane. The digital channel consists of a lunar guidance computer, inertial measurement unit, coupling data unit, and astronaut display and keyboard, all taken from the Apollo guidance and navigation system. A mode and power panel permits the pilot to request the lunar guidance computer to make mode and gain changes. The three-channel backup control system consists only of surface position command electronics. Specially designed electro-hydraulic secondary actuators interface the primary and backup electronic commands with the conventional F8 control surface power actuators.

Figure 4 shows the general arrangement of the flight control system hardware in the F8 airplane. Five secondary actuators were required, one for the rudder and one each for the two horizontal stabilizers and the two ailerons. The Apollo lunar guidance computer is the heart of the primary control system and performs all flight control computations.

The DFBW system is described in more detail in Reference 3.

## TEST RESULTS

Measurements were made at a variety of primary and backup system interfaces. Of greatest interest were the induced voltages appearing at the wiring interfaces with the primary DFCS system, which includes the Apollo lunar guidance computer (AGC). Figures 5, 6 and 7 show some of the measurements. For all of these measurements the simulated lightning current entered the nose and exited from the tail of the aircraft. Figure 5 shows measurements made at the J25 interface on circuits coming from the mode and power control panel and stick, BCS and yaw trim transducers in the cockpit area. These appear as damped oscillations at a fundamental frequency of about 1 megahertz. Most of the voltage has subsided after about 6 microseconds has elapsed. Each voltage shown on Figure 5 is a damped oscillation at a fundamental frequency of about 1 megahertz since all conductors follow the same bundle to the cockpit. The waveforms have slight variations which are probably due to differences in load impedances at each end.

Figure 6 shows voltages induced in the pitch, roll and yaw control sensor circuits coming to the DFCS computer, but the measurements were made at plug P4 with this plug disconnected from the DFCS system. These, therefore, are open circuit voltages and are not necessarily the same as the voltages which might appear at the closed interface, since DFCS input impedances would affect the voltages impressed across them. The characteristic frequencies of the open-circuit voltages measured at pins D-E (osc. 528), G-H (osc. 525), W-X (osc. 523) and Y-Z (osc. 526) have a fundamental frequency of about 1.7 megahertz with lower amplitude oscillations of several higher frequencies superimposed. These are induced in circuits coming from the DFCS stick transducer in the cockpit. The fundamental frequency of voltages measured at pins A-B (osc. 524) and U-V (osc. 527) in circuits coming from the rudder pedal transducer in the tail area is also 1.7 megahertz but without as much of the superimposed higher frequency component. Neither fundamental frequency is the same as that measured at the closed J25 interface in circuits also coming from the cockpit area.

The closed circuit J2 interface measurements shown on Figure 7 are of the same 1 megahertz fundamental as those measured at the J25 interface of Figure 5, except that the polarity is reversed.

## DISCUSSION OF RESULTS

### Induced Voltages

Study of the induced voltages measured in this system indicates that they are primarily of aperture magnetic flux origin due to the absence of long-duration unidirectional components induced by diffusion magnetic flux appearing inside the airframe when lightning current has diffused to the inside of its skin. Indications of structural IR voltage components are also absent, as expected, since the system is single-point grounded and has no direct reference to the airframe at locations remote from the DFCS pallet where these measurements were made. The single-point ground to the airframe is at the DFCS pallet.

The most prevalent frequency of oscillation of induced voltages measured at the DFCS interface is about 1 megahertz. This is not the same frequency as the oscillations superimposed on the simulated lightning current wavefront, which is 2.6 megahertz. In fact, there is no similarity between this frequency and that of induced voltages measured anywhere in the DFCS system. Fourier transformations were made to determine the frequency spectral distribution of the actual lightning test waveform as compared with an idealized smooth-front waveform.

Spectral peaks above the smooth-front waveform distribution occur in the test waveform distribution at 2.5, 5 and 8 megahertz, but not at the 1 megahertz frequency of the induced voltages measured at the DFCS interfaces.

The induced voltages reach their maximum during the first several microseconds of lightning current flow, which is when the lightning current and corresponding aperture flux are changing most rapidly. Continued oscillations appearing for several more microseconds are most likely the result of subsequent traveling waves in the circuit being measured. If this is so, the frequency of these voltages is primarily a function of the distributed circuit inductance and capacitances.

The variation in fundamental frequencies and presence of more than one frequency component in a single voltage is probably due to variations in circuit routing and interconnections with other circuits in the system.

The ranges of voltage amplitudes measured at the DFCS interfaces, when scaled to a 200,000 ampere (fast) lightning waveform, are presented in Table I.

Table I - Range of Induced Voltage Amplitudes  
(Scaled to  $i_L = 200 \text{ kA}$ )

<u>INTERFACE</u>	<u>INDUCED VOLTAGE AMPLITUDE</u> (0 - Peak Volts)	
	<u>MIN.</u>	<u>MAX.</u>
Stick Trim and MPC Inputs to DFCS (J25)	233	900
Stick Transducer Inputs to DFCS (P4)	40	87
DFCS Control Outputs (J2)	233	400
BCS Control Inputs (J12)	222	422
Mode and Power Control (J15)	833	1132
Mode and Power Control (J14)	213	732
Power Dist. Bay (+28VDC BUS)	160	200
DFCS Ground to A/C Ground	-	666

Voltages measured at other locations in the DFBW system, such as at the secondary actuators and BCS electronics, were of generally similar magnitudes.

## Impact on DFCS System

The expected impact of the induced voltages measured in the DFCS system on system operation was analyzed by DELCO Electronics, manufacturer of the DFCS. Comparison of individual component vulnerability data, when available, with induced voltage levels at single circuit interfaces was utilized to determine vulnerability of system components and effect on circuit operation. In other cases, best engineering judgment was used. An example of such an assessment is the attitude (yaw, pitch or roll) gain logic power circuits (pins A-W) from the MPC panel to the DFCS pallet. The schematic diagram of one of these circuits is shown on Figure 8. Induced voltages at the J25 interface are shown on Figure 5 (i.e. osc. 505). The voltages at the J25 interface (DFCS) ranged from 566 to 865 volts, and at the J15 interface (MPC), 1065 to 1132 volts. At the MPC, the induced voltage exceeds the 1000 volt (at sea level) dielectric breakdown rating of the switch. Arc-over may therefore occur either to case and mounting or between contacts, with a possibility of switch failure.

This circuit (+28 VDC) provides a request to the computer to change attitude control loop gain. If the wiper arm of the switch burns open, the computer will notice no gain requests and under this condition is programmed to assume attitude gain position 1. The DFCS control will survive at this gain position. If the switch would short such that two gain-position requests exist, the computer is programmed to assume the lower gain of the two requests. The DFCS control will survive.

At the AGC, the induced voltage exceeds the 500 volt dielectric breakdown rating of the 20K resistor, R2. Arc-over of R2 may then expose capacitor C1 to damaging overvoltage, causing it to short circuit. If it remains shorted during the entire lightning flash, no further damage should occur. If C1 opens between successive strokes of a multiple stroke flash, arc-over(s) of the 1.5K resistor R4 on successive strokes may permanently destroy transistor Q1. If C1 is short circuited, the AGC gain change circuit will be inhibited. Selection of this gain position after the lightning flash will cause the computer to select attitude gain position 1. The DFCS control will survive at that gain position. The same applies if transistor Q1 fails.

As another example, the DFCS digital control output circuits are considered. The schematic diagram of these circuits is shown on Figure 9. Induced voltages measured at the J2 interface are shown on Figure 7 and range from 233 to 400 volts. Those measured at the P12 end ranged between 222 and 422 volts. At the DFCS, capacitor C2 has a 15V rating. Therefore it would

break down as a short circuit. The capacitor could then fail as an open circuit. In either case the remaining circuit components would probably survive the lightning stroke. These are dual circuits which provide attitude commands which are utilized as control surface inputs. The dual outputs are compared to each other for failure detection purposes. Since capacitor C2 can be failed as an open or short circuit, several combinations were considered. If C2 is shorted as a dual output, no failure detection would occur. The pilot would discover that a problem existed only by noting the lack of aircraft response to control stick position. If one of the dual command outputs contained C2 open circuited and the other short circuited, any off-neutral control stick position would trigger the failure detection circuit which would remove that attitude axis control from DFCS to the BCS. In the case of C2 open-circuited as a dual output, DFCS aircraft attitude control could be maintained.

Other individual circuits were assessed in the same manner. Failure in some circuits is likely to degrade DFCS performance, but in others, the consequences appear minimal. It is evident, from Figures 5, 6 and 7, that lightning-induced voltages appear simultaneously in all DFCS circuits.

They also appeared in the 3 BCS channels. Thus, the consequences of simultaneous failures in many circuits must be fully assessed before the total impact on system operation can be determined. This has not been accomplished for this system. In general, however, it was found that many DFCS components are vulnerable to the induced voltages expected from a 200,000-ampere lightning stroke. The most vulnerable components are capacitors, transistors, and relay arc-suppression diodes. The least vulnerable components that may be damaged are switches, relays, forward loop diodes, and inductors.

It should be remembered that the DFCS equipment is an adaptation of existing Apollo Lunar Module equipment that was not designed to survive lightning-induced voltages, and also, that a 200,000 ampere stroke is likely to occur only about 1% of the time. The average amplitude is about 30,000 amperes. Under this condition, component vulnerability is reduced.

## CONCLUSIONS

This program represents the first experimental investigation of lightning-induced effects on a fly-by-wire system, digital or analog. The results of this study are therefore significant, both for this particular aircraft and for future generations of aircraft and other aerospace vehicles such as the Space Shuttle, which will employ digital fly-by-wire flight control systems. Particular conclusions from this work are as follows:

1. Equipment bays in a typical metallic airframe are poorly shielded and permit substantial voltages to be induced in unshielded electrical cabling inside.
2. Lightning-induced voltages in a typical aircraft cabling system pose a serious hazard to modern electronics, and positive steps must be taken to minimize the impact of these voltages on system operation.
3. Induced voltages of similar magnitudes will appear simultaneously in all channels of a redundant system.
4. A single-point ground does not eliminate lightning-induced voltages. It reduces the amount of diffusion-flux induced and structural IR voltage but permits significant aperture-flux induced voltages.
5. Cable shielding, surge suppression, grounding and interface modifications offer means of protection, but successful design will require a coordinated sharing of responsibility among those who design the interconnecting cabling and those who design the electronics. A set of Transient Control Levels for system cabling and Transient Design Levels for electronics, separated by a margin of safety, should be established as design criteria. Data from this and other experimental programs should be utilized to help establish these criteria.

## REFERENCES

1. Walko, L.C., "A Test Technique for Measuring Lightning-Induced Voltages on Aircraft Electrical Circuits", NASA CR-2348, General Electric Corporate Research and Development Report No. SRD-72-065, January, 1973.

2. Berger, K., "Novel Observations on Lightning Discharges: Results of Research on Mount San Salvatore", Journal of the Franklin Institute, Vol. 283, pp. 478-525, June, 1967.
3. Deets, D.A. and Szalai, K.J., "Design and Flight Experience With a Digital Fly-By-Wire Control System in an F-8 Airplane", AGARD paper.

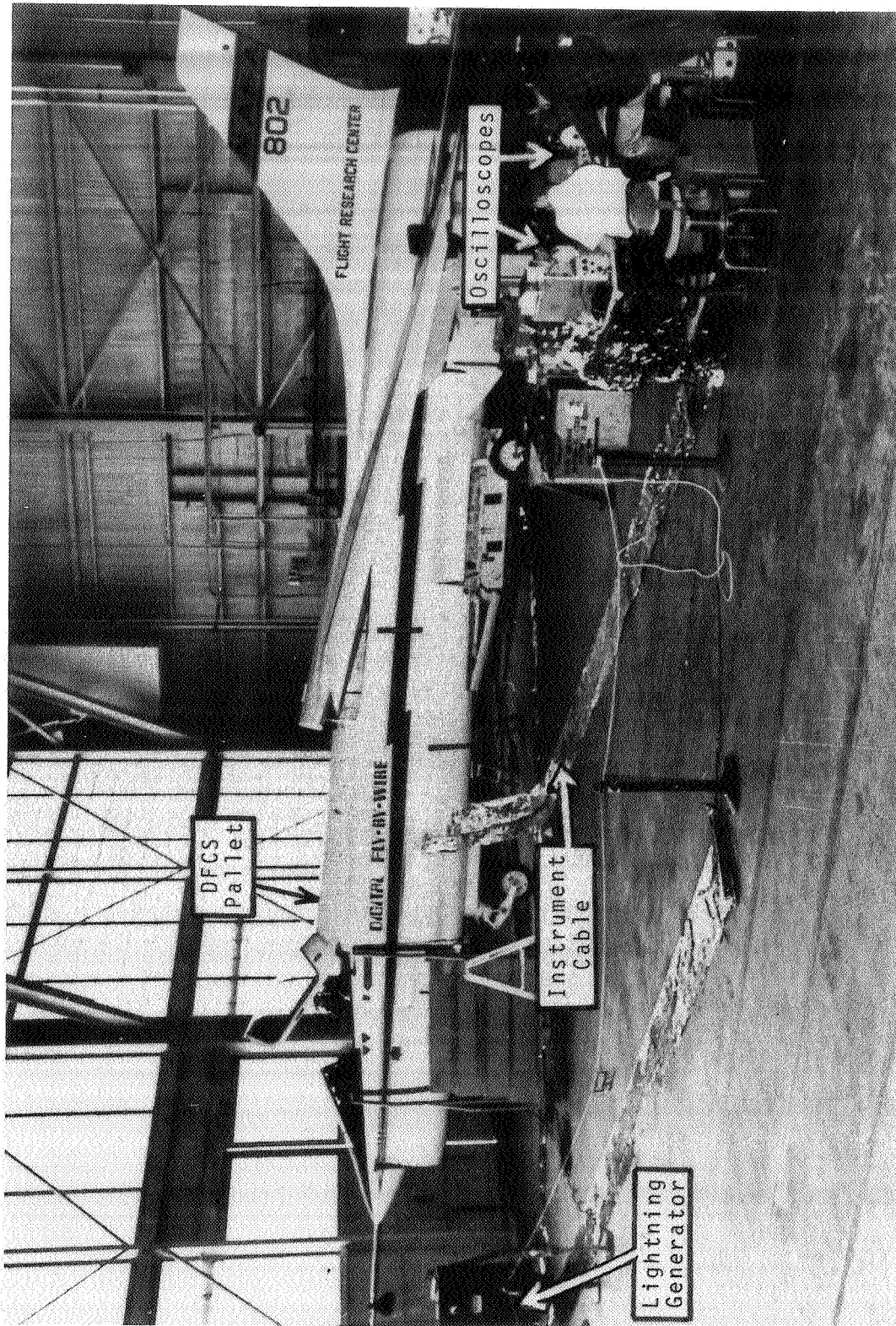
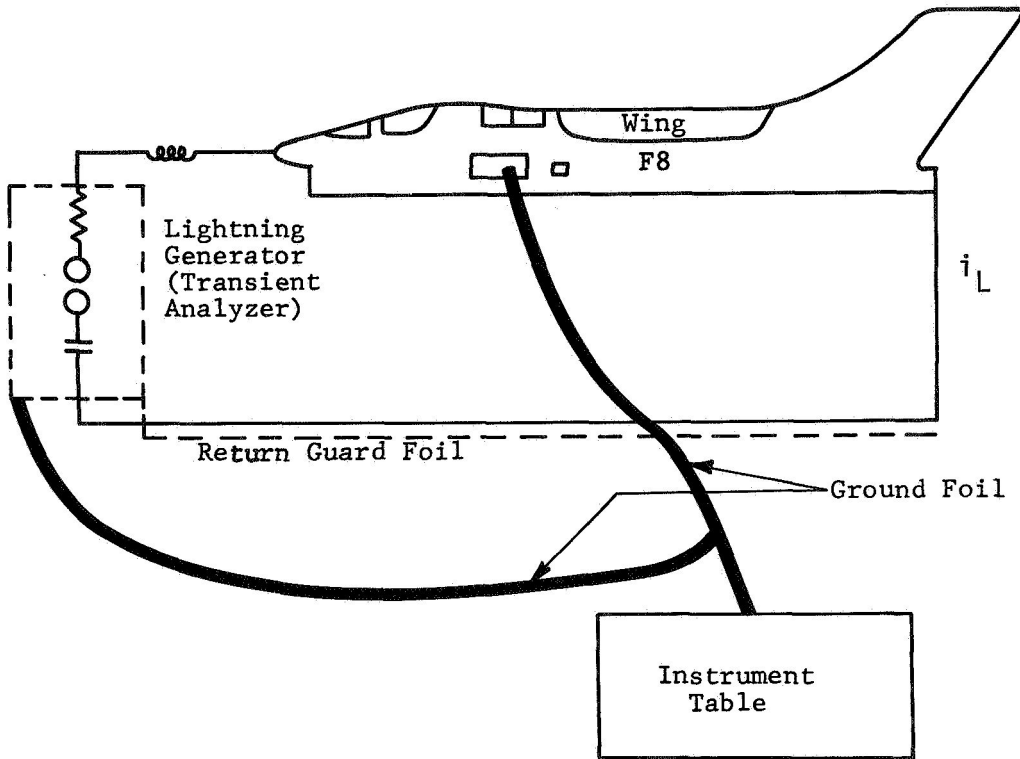
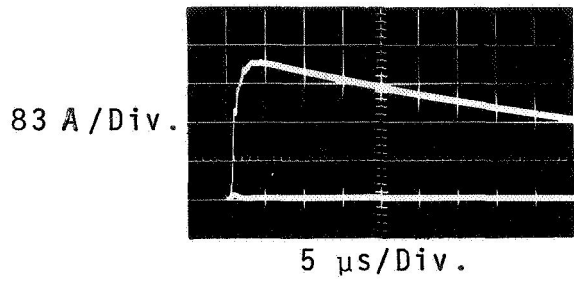

FIGURE 1 - TEST SETUP FOR MEASUREMENT OF LIGHTNING-INDUCED VOLTAGES IN NASA F8 DFBW AIRPLANE.



Simulated Lightning Current  
300 Amperes Peak



a) Actual Test Circuit

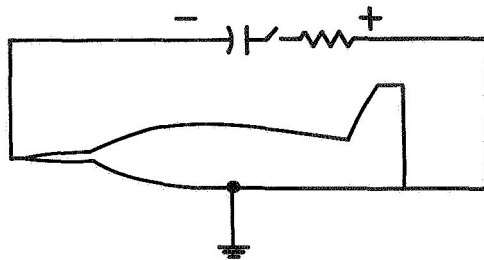

b) Equivalent Test Circuit

FIGURE 2 - SIMULATED LIGHTNING WAVEFORM AND TEST CIRCUIT

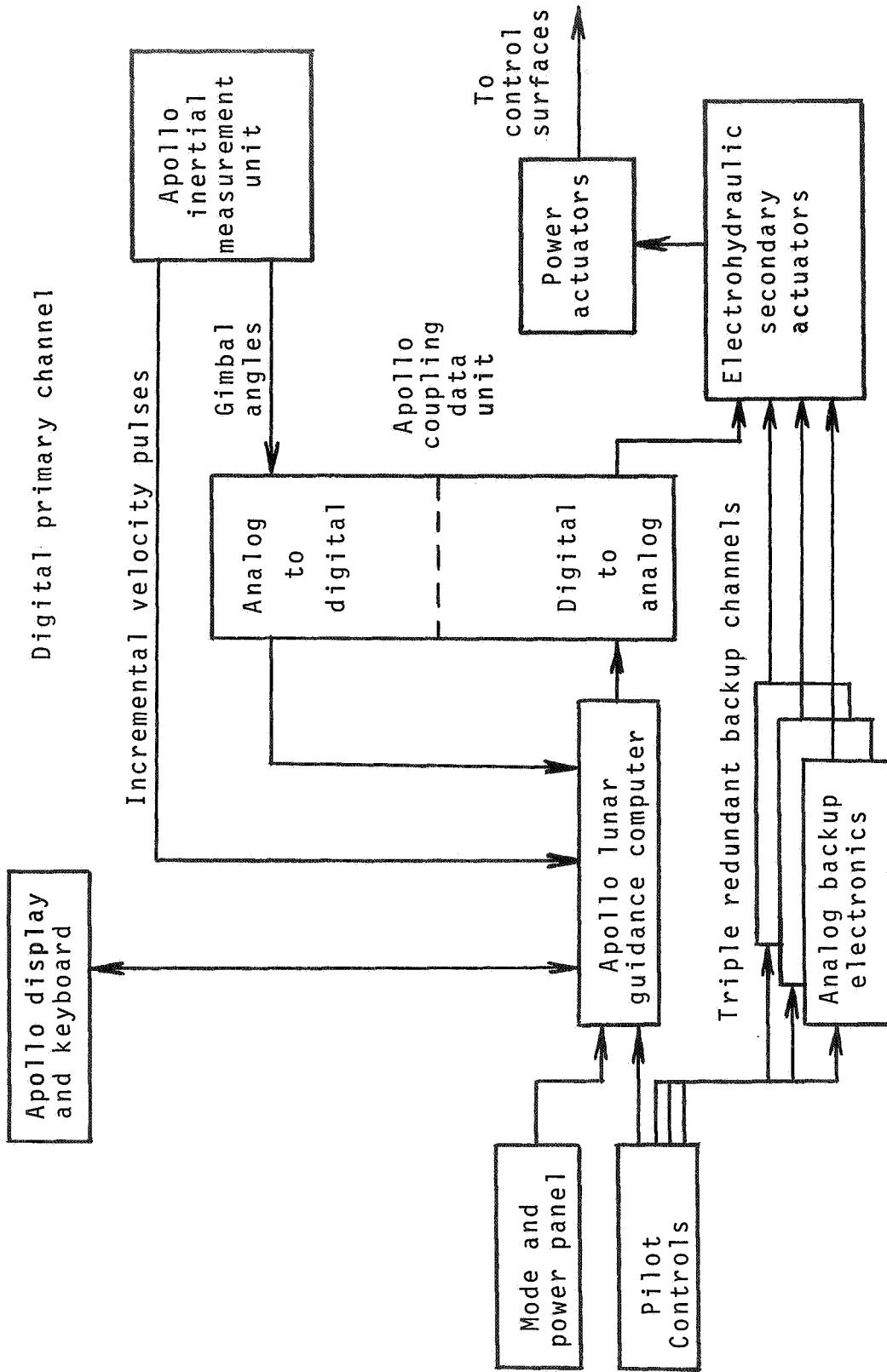

FIGURE 3 - F-8 DIGITAL FLY-BY-WIRE CONTROL SYSTEM HARDWARE ELEMENTS.

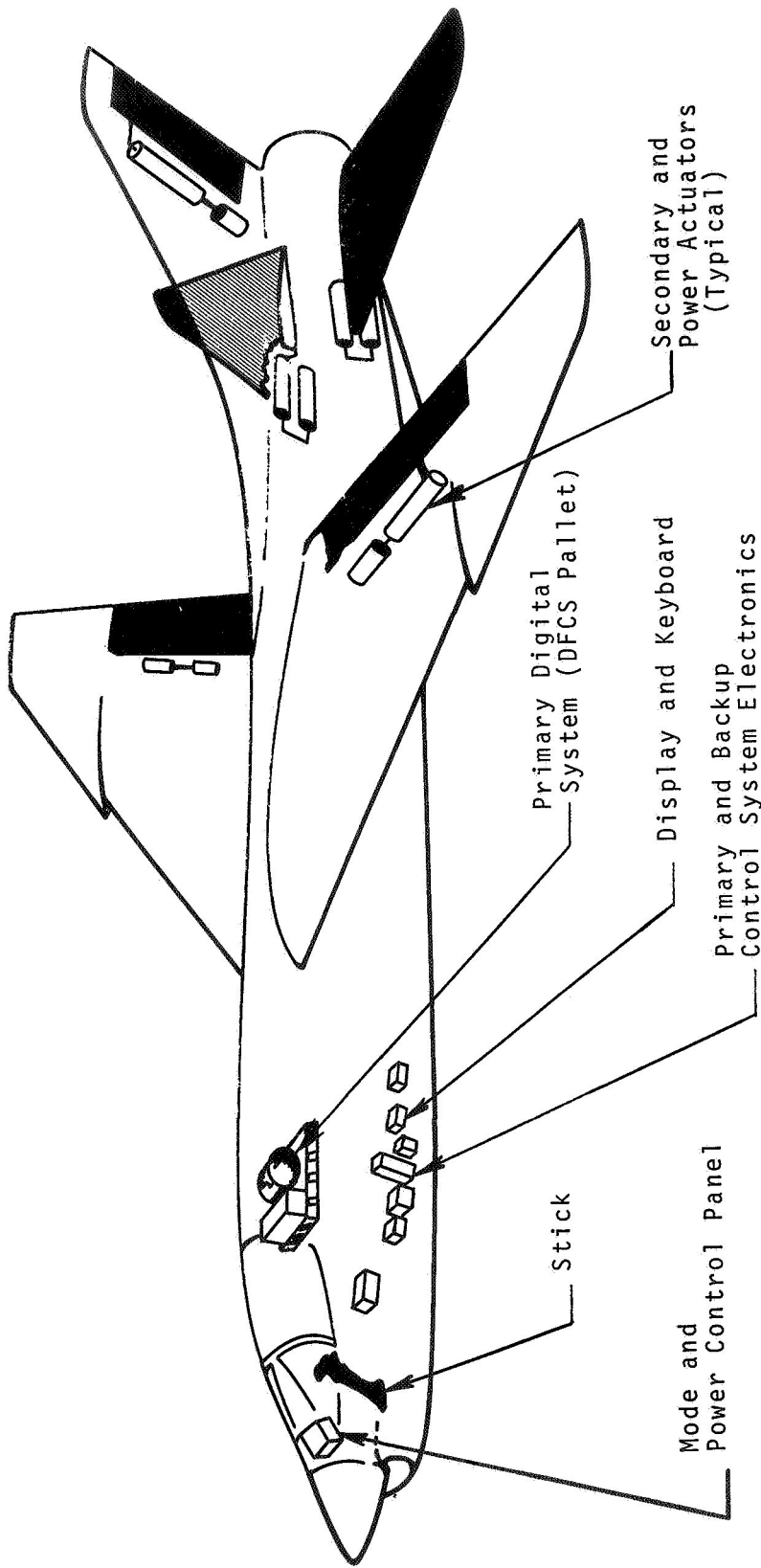
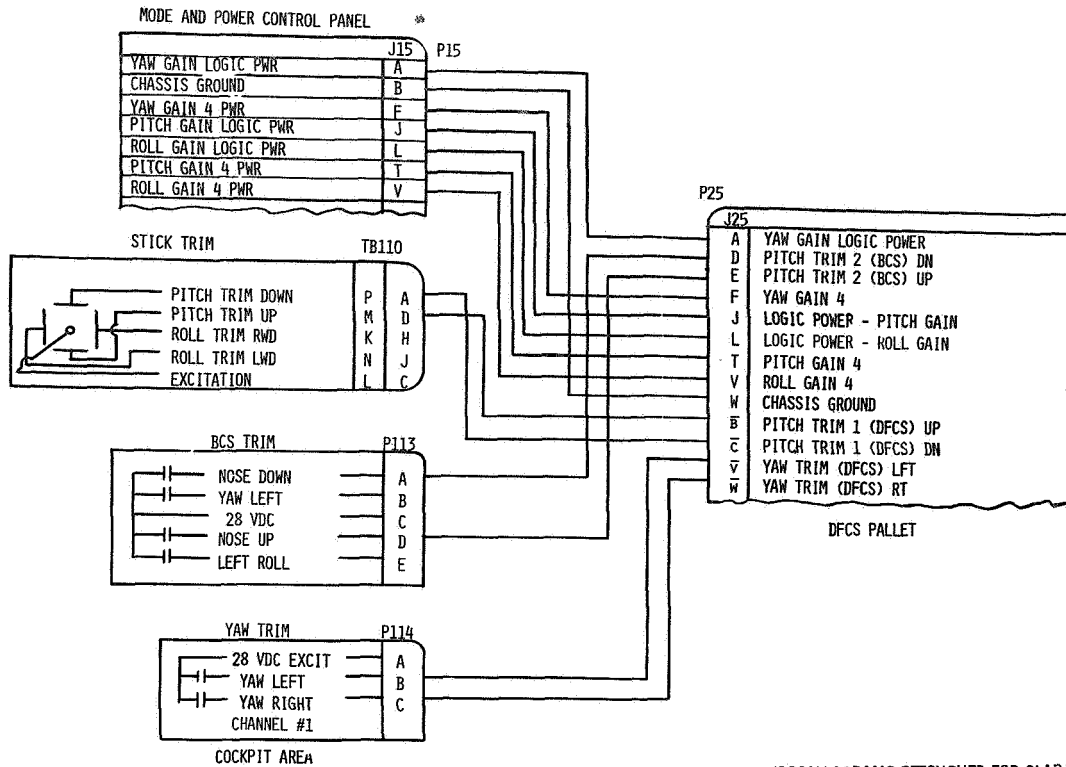

FIGURE 4 - LOCATION OF FLY-BY-WIRE CONTROL SYSTEM HARDWARE IN F8 AIRPLANE .



(OSCILLOGRAMS RETOUCED FOR CLARITY.)

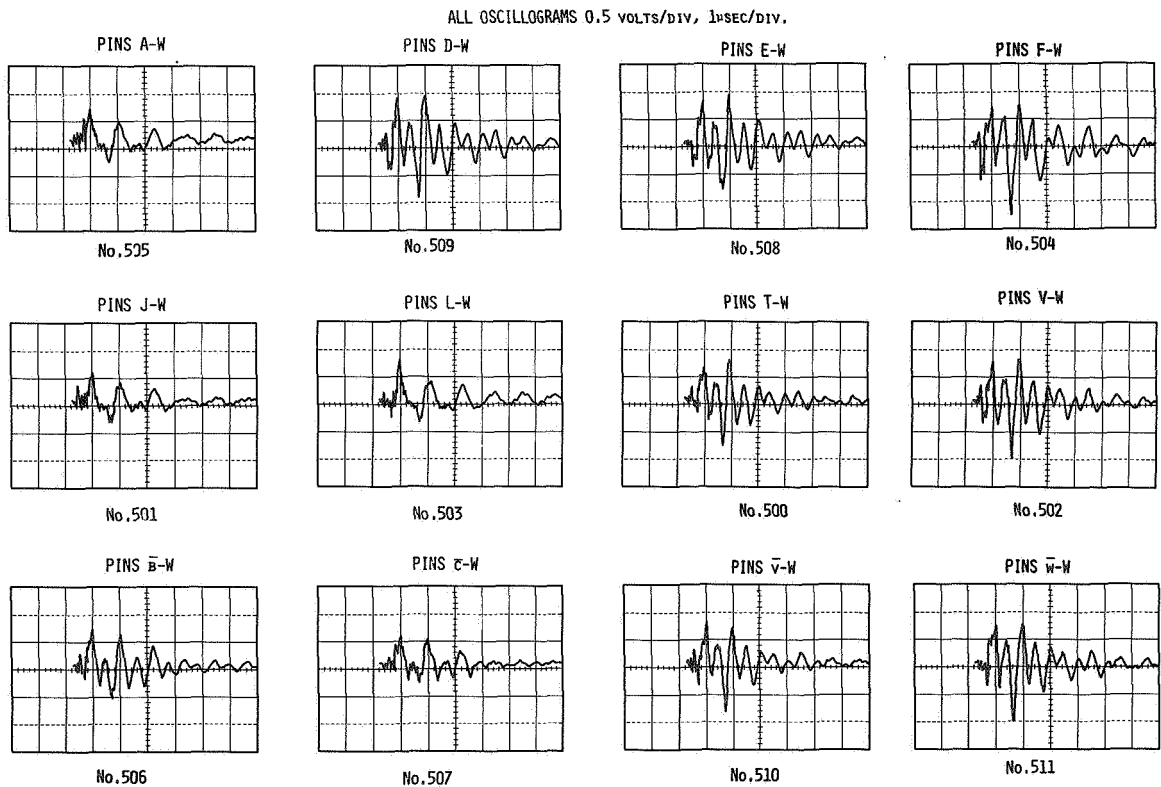
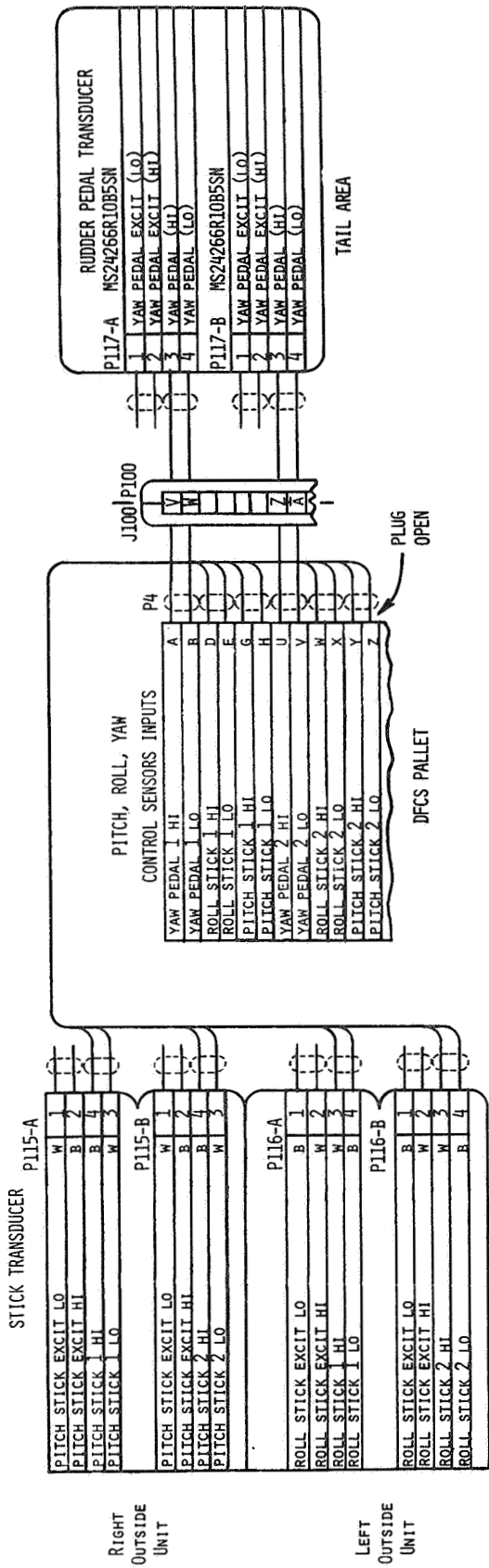

FIGURE 5 - INDUCED VOLTAGES ON MPC AND STICK TRIM INPUTS TO DFCS AT J25 INTERFACE.



(OSCILLOGRAMS RETOUCHESED FOR CLARITY.)

ALL MEASUREMENTS ON CONNECTOR P4  
ALL OSCILLOGRAMS 0.1 VOLTS/DIV, 1μSEC/DIV.

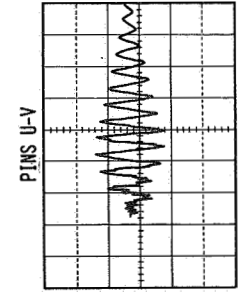
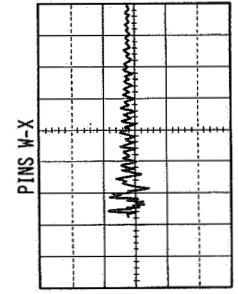
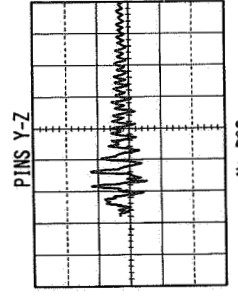
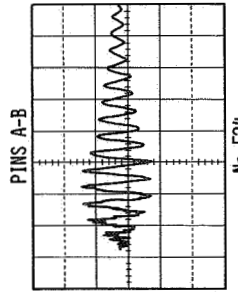
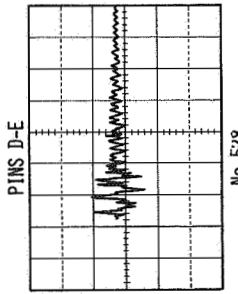
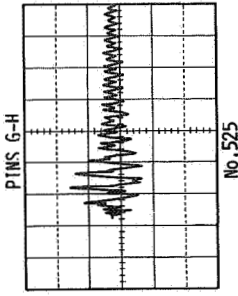
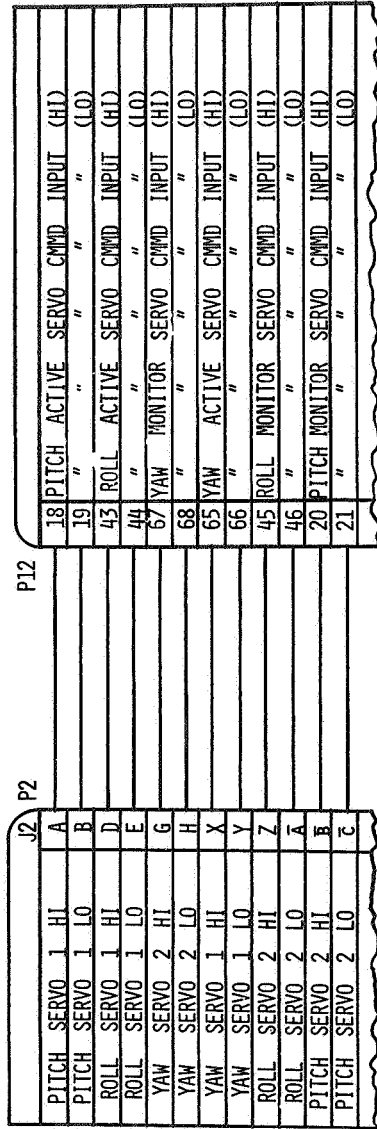

FIGURE 6 - INDUCED VOLTAGES ON CONTROL SENSOR INPUTS TO DFCS AT P4 (OPEN).

DFCS Digital Control  
Digital-to-Analog  
Converter

Primary Control Electronics #1



DFCS PALLET

LEFT GUN BAY

(OSCILLOGRAMS RETOUCHE FOR CLARITY.)

ALL MEASUREMENTS: 0.5 VOLTS/DIV, 1 μSEC/DIV.

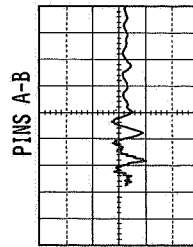

No. 514

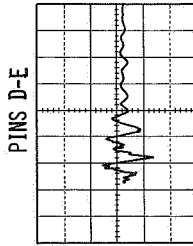

No. 516

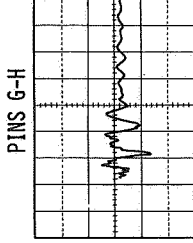

No. 518

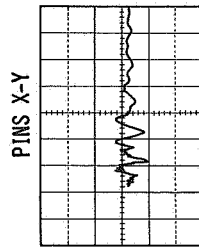

No. 515

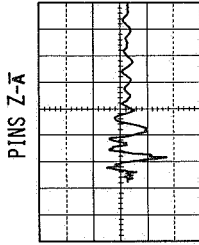

No. 517

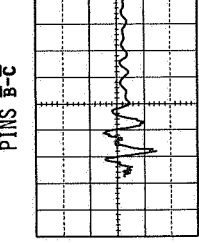

No. 519

FIGURE 7 - INDUCED VOLTAGES ON DFCS DIGITAL CONTROL CIRCUITS AT J2 INTERFACE.

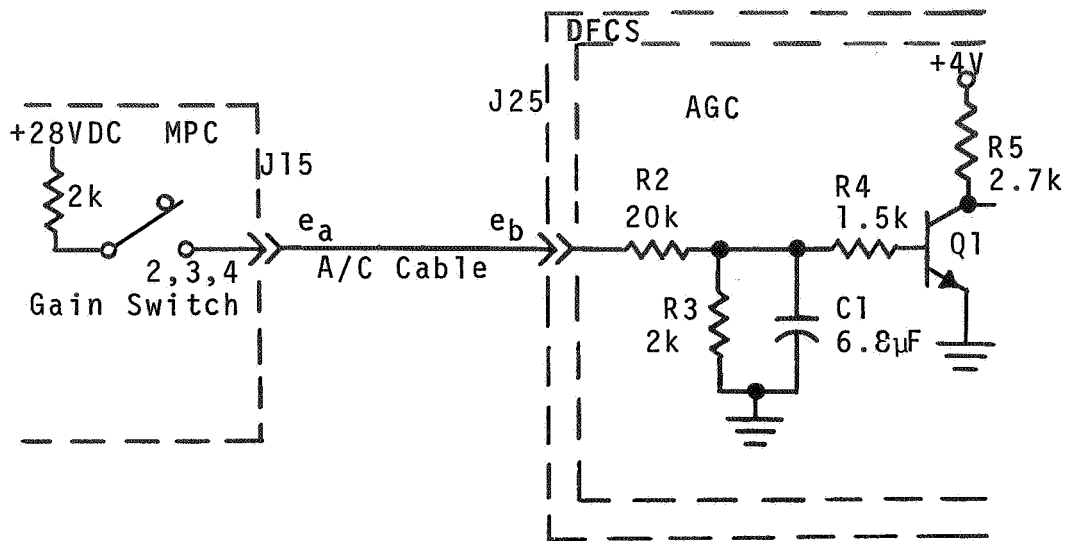

J15 Interface

$e_a$  average = 1119 V<sub>(o-p)</sub>

$e_a$  range = 1065 to 1132 V

f = 1.0 MHz

No. of measurements = 5  
 (J15: Yaw & Roll Gain 4;  
 Not Shown in Figures)

J25 Interface

$e_b$  average = 677 V<sub>(o-p)</sub>

$e_b$  range = 566 to 865 V

f = 1.0 MHz

No. of measurements = 3  
 (J25: Yaw, Pitch & Roll  
 Gain 4 - Fig.6, osc. 505,  
 500,502)

FIGURE 8 - ATTITUDE GAIN SWITCH POSITION 2, 3, and 4  
 SIGNAL CIRCUIT FOR DFCS AND MPC INTERFACE.

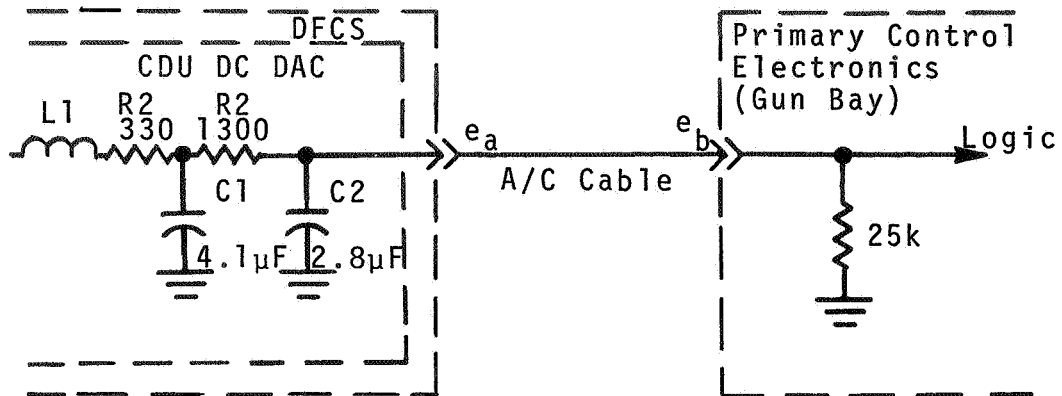

$e_a$  average = 316 V<sub>(o-p)</sub>

$e_b$  average = 355 V<sub>(o-p)</sub>

$e_a$  range = 233 to 400 V<sub>(o-p)</sub>     $e_b$  range = 222 to 422V<sub>(o-p)</sub>

$f = 1.0$  MHz

$l = 1.0$  MHz

No. of measurements = 6  
(J2: Yaw, Pitch and Roll  
DACs' 1 and 2, Figure 7)

No. of measurements = 3  
(Yaw, Pitch and Roll  
primary commands)

FIGURE 9 - DFCS DIGITAL CONTROL DIGITAL-TO ANALOG  
CONVERTER OUTPUT SIGNAL CIRCUIT TO  
PRIMARY CONTROL ELECTRONICS.



## 5. MAN-RATED FLIGHT SOFTWARE FOR THE F-8 DFBW PROGRAM

Robert R. Bairnsfather  
The Charles Stark Draper Laboratory, Inc.

### SUMMARY

The design, implementation, and verification of the flight control software used in the F-8 DFBW program are discussed. Since the DFBW utilizes an Apollo computer and hardware, the procedures, controls, and basic management techniques employed are based on those developed for the Apollo software system. Program Assembly Control, simulator configuration control, erasable-memory load generation, change procedures and anomaly reporting are discussed. The primary verification tools—the all-digital simulator, the hybrid simulator, and the Iron Bird simulator—are described, as well as the program test plans and their implementation on the various simulators. Failure-effects analysis and the creation of special failure-generating software for testing purposes are described. The quality of the end product is evidenced by the F-8 DFBW flight test program in which 42 flights, totaling 58 hours of flight time, were successfully made without any DFCS inflight software, or hardware, failures or surprises.

### INTRODUCTION

From early 1971, CSDL participated in Phase 1 of the Digital Fly-by-Wire program being administered by NASA Flight Research Center (NASA/FRC). Overall program effort was directed toward a series of demonstration Fly-by-Wire (FBW) aircraft flights. A triply redundant Analog Fly-by-Wire (AFBW) Backup Control System (BCS), employing a simple open-loop control algorithm, is coupled with the primary flight control system to provide the two-fail-operate/fail-safe reliability necessary for severing mechanical linkages. The simplex Digital Fly-by-Wire (DFBW) Primary Control System (PCS) has both software and hardware failure-detection capability in the digital computer. There are also independent monitoring and failure-detection modules operating on PCS control commands, power supplies, pilot input devices, and other critical areas. Finally, there is the capability for pilot-initiated downmoding to BCS via several independent paths. There are seven selectable PCS flight control modes available. Three Direct (DIR) modes consist of pilot stick/pedal plus trim applied directly to the control surfaces. Three Stability Augmented System (SAS) modes incorporate body-axis angular rates (and lateral acceleration) as feedback variables. The Command Augmented System (CAS) mode is basically pitch SAS with normal acceleration feedback and forward-loop integral bypass. The only BCS mode, Direct, is also selectable by axis.

The first Fly-by-Wire flight was made on 25 May 1972, in the high performance F-8C fighter assigned to the DFBW program. Takeoff and landing were made in PCS/DIR. Basic performance and handling qualities were demonstrated at several flight conditions, both in BCS and PCS/DIR. Closed-loop PCS/SAS was first flown on 18 August 1972 with subsequent flights building toward full system capability. The demonstration flight test program continued through late 1973.

The CSDL role in the F-8 DFBW program has been directed at the PCS software, hardware, and peripherals. Specific tasks have been: the hardware design, development, and testing of the uplink and downlink converters, the PIPA Simulator, and the Gimbal Angle Simulator; and software design, implementation, and verification of the NASA/FRC three-axis Primary Control System algorithms; the functional design, software design, production, and verification of the mode and gain change routines, miscellaneous ground test programs, and open-loop inflight earth-rate torquing routine; the interface design including failure analysis; simulation support; the review and verification of preflight erasable loads.

### The F-8 DFBW System

Aircraft—The F-8C Crusader, a carrier-based U.S. Navy fighter of mid-50's vintage, is a high-performance single-seat aircraft capable of Mach 1.8 flight at altitudes of 60,000 feet. NASA/FRC obtained several surplus aircraft of the F-8 series. Two of them are involved in the F-8 DFBW program, one as the flight article and one as the Iron Bird Simulator test article. Figure 1 depicts the F-8C aircraft, showing the physical distribution of key F-8 DFBW hardware. Descriptions of the hardware are given in Table 1 and Table 2.

Digital System—The digital computer used by the PCS is the general purpose Apollo/LM Guidance Computer (LGC). An Apollo Inertial Measurement Unit (IMU) provides attitude angles, angular rates, and linear accelerations for feedback control. Major considerations for using the Apollo hardware were that it possessed a demonstrated reliability and flexibility. Moreover, surplus LM hardware was available from cancelled Apollo missions. Experienced teams of software and hardware specialists were also available, for software and systems integration tasks, at CSDL and Delco Electronics. A functioning Operating System software existed for the LGC, in addition to the supporting facilities of the powerful Assembler software, the All-Digital Simulator, and two hardware-integrated simulators at CSDL. Starting with this framework meant that a significant portion of the development task was already completed. There were some disadvantages, the most significant being the July 1972 scheduled shutdown of the core-rope manufacturing facilities for the LGC fixed memory. Another disadvantage, although not recognized immediately, was that the F-8C performance envelope exceeded the design capabilities of some Apollo hardware items. This influenced the digital flight control system (DFCS) performance, and required a reduced performance envelope, which, while less than F-8C capabilities, was nevertheless acceptable for an experimental digital fly-by-wire testbed.

Computer—The LGC contains two distinct memories, fixed and erasable, as well as hardware logic circuits. The fixed memory is stored in a wire braid which is manufactured and installed in the computer. This memory cannot be changed after manufacture and it can only be read by the computer. Fixed memory contains 36,864 words of memory grouped into 36 banks. Each word contains 15 bits of information, plus a parity bit. The erasable memory makes use of ferrite cores which can be both read and changed. It consists of 2048 words divided into 8 banks. Erasable memory is used to store such data as may change up to or during a mission, and is also used for temporary storage by the programs operating in the computer. The memory cycle time (MCT) in the LGC is 11.7  $\mu$ s. Most single-precision instructions are completed in two MCTs; most double-precision machine instructions are completed in three MCTs.

## SOFTWARE DEVELOPMENT

The software control procedures employed for F-8 DFBW selectively follow those developed and successfully applied during the generation of software program assemblies for the Apollo command and lunar module computers. A continuation of useful procedures, made necessary because the F-8C uses the same Apollo hardware, and desirable because of schedule limitations, was easily imposed by the CSDL personnel connected with F-8, all of whom were contributors to the Apollo effort. The limited scope of F-8 dictated some changes in procedure, but these were basically simplifications commensurate with the level of effort. After all, approximately 400 man-months/month were expended in Apollo by CSDL programming and engineering groups just prior to the first lunar landing, while F-8 DFBW peaked at about 9 man-months/month. The critical time span was from Control Law Specification delivery in March of 1971 until program release for fixed-memory core-rope manufacture in mid-December of 1971. Since that date, CSDL has supported Preflight Erasable Load generation, failure analysis, preflight procedure preparation, and Erasable Memory Program development and verification. The timely development and excellent flight-test performance of DFBW software attest to the effectiveness of the control procedures employed. It is worth emphasizing that we now have more modern software techniques, but that Phase 1 of F-8 DFBW was a basic evaluation program, and utilized off-the-shelf software as well as hardware. Approximately 85 man-months and 95 hours of IBM 360/74 computer time were required for the Phase 1 software design, implementation, and verification tasks. The F-8 chronology is shown in Fig. 2.

## Operational Software

The operational software for F-8 DFBW consists of two basic categories: the DFCS Program Assembly, and the Preflight Erasable Load Assembly. In the finished product, the DFCS Program Assembly is embodied in the core rope and comprises the computer's fixed memory. At this stage, it has become hardware and is effectively a breadboard autopilot in that the structure is invariant while most parameter values and switch words are variable. For F-8 DFBW, there is only one final Program Assembly, from which the flight rope and an identical

spare are manufactured. The Preflight Erasable Load Assembly is embodied in a tape and comprises the computer's Initial Data Load. The tape, KSTART, contains parameter values and switch settings required by the program, and the computer receives it as a part of each power-up sequence. A new Preflight Erasable Load Assembly is made whenever a flight test requires new parameter values. To ensure the high degree of reliability and safety that is necessary for man-rated flight software, both assembly processes are carefully controlled.

### Program Assembly

The Program Assembly has two main functional areas: Systems and Applications. Grouped under Systems are Executive, Restart, and Service. Applications covers Flight Control, and Miscellaneous. The Executive code includes the priority job-queue processor, the time task-queue processor, the time-dependent interrupt processor, the idle-job routine. The Restart code includes the hardware restart interrupt processor, computer initialization routine, the program alarm processor, the restart-group phase-control routines. The Service code includes the list-processing interpreter, the IMU monitor, the computer self-test routines, the man-machine interface routines, the interrupt processors. The Flight Control code includes the autopilot initialization routine, the mainline processor, the filter pushdown and wrap-up processor, the input discrete processor, the Mode and Gain change processor, the body transformation matrix processor. The miscellaneous code includes the ground test programs, and special-purpose applications routines.

In several areas, the flight control requirements and the LGC characteristics posed interesting problems. Some of these are singled out.

Duty Cycle—Early in the development process it became clear that the Flight Control system would create a relatively high duty cycle in the LGC due to several causes: LGC instruction time (24  $\mu$ s/instr), the flight control sample period (30 ms) and the generalized nature of the control system. Since the entire LGC is devoted to the DFCS, words of code could be traded for increased time efficiency wherever possible; that is, code is designed for minimum execution time rather than for minimum storage. Time savings are also realized for control parameters, where combinable multiple parameters are replaced by an equivalent single parameter in a working register, whose value is generated only once by program initialization.

Restart Protection—A hardware restart is a special interrupt that takes precedence over all other interrupts, and that cannot be inhibited. The hardware restart is triggered by circuitry in event of selected computer malfunctions. On completion of the restart, all output channel discrettes are cleared, and computer control is transferred to a specific memory location, i.e., to the Restart Routine. The Restart software rapidly reestablishes the channel output interfaces because F-8C control surface commands and the PCS primary-enable signals depend on a viable interface. The restart software next restores the program flow by reestablishing the job-queue and time-queue, and by causing the program whose execution was interrupted to resume at the latest restart

point. Restart points are entry points, breaking program flow into separate blocks, such that a properly restart-protected program will reproduce the same values after a restart as before.

In general, a repetition of code execution is involved following a restart because the nature of the LGC requires software recovery procedures. However, the repetition requires that special care be taken during code generation to avoid creating situations where a restart will cause a multiple update of a variable. For example, if the operation  $A+B \rightarrow A$  occurs between two restart points, then A is updated at each pass through the code. This violates the rule that the values generated by code repetition after a restart must be the same as before. The situation of multiple updates is avoided by a copy cycle, which involves an intermediate variable and an additional restart point. For the example we have  $A+B \rightarrow C$ , followed by the new restart point, followed by  $C \rightarrow A$ . Clearly, the final value of cell A is unaffected by code repetition. Copy cycles are common in Apollo code and have the advantage of economy of erasable memory usage although they are expensive in terms of execution time. Note that cell C is intermediate and can be used by many copy cycles.

Rather than use copy cycles, F-8 DFBW prefers a method that, because of the high DFCS duty cycle, is conservative of time but is expensive in fixed and erasable memory cells, doubling the number. Two functionally identical strings of code, a J-branch and a K-branch, are required with processing alternating from one to the other. Two equivalent sets of erasables are required, also J-branch and K-branch. The J-branch code uses K-branch (past value) outputs plus J-branch (present value) inputs to compute J-branch (present value) outputs. No special copy cycles are required, and computations are efficiently performed. Copy cycles would likely have pushed DFCS duty cycle dangerously close to 100%. It reaches 91% even with time-efficient restart protection.

Indirect Transfer—At sixteen critical points in F-8 DFBW program flow, and at one point in the downlink program, a capability is provided for erasable indirect transfer of control. In application the program flow of the hardware core-rope fixed memory program is determined by the address contained in a specific erasable cell at the time the cell is accessed by the program. Erasable cells used in this manner fall into two classes. There is the class of cells whose contents (the destination address) is changed regularly under program control, say every 20 ms or 30 ms. These cells, although erasable, form an integral part of the core-rope. The second class consists of cells whose contents are in general established only once, either by an initialization pass or by the Initial Data Load (KSTART tape). It is this second class of erasable cells that provides the powerful capability of altering the program flow after core-rope manufacture by means of Erasable Memory Programs.

Generalized Filters—Inasmuch as F-8 DFBW is a flying breadboard, the feedback sensor quantities are each provided with a generalized filter. The five filters, three for body rates and two for linear accelerations, allow flexibility of filter choice: bypass, first order, second order, and third order. An alternate third order is obtained by cascading the first and second

order sections to obtain control over individual poles and zeros. The filter coefficients are parameters in the KSTART tape. The filters are active at all times, even in BCS/DIR.

The computations are divided into two phases, the main phase which incorporates the current input with past values to update the output, and the pushdown or wrap-up phase which updates the other filter quantities in preparation for the next cycle. In this manner the control surface commands which use the filter outputs are generated with the shortest delay. The time-consuming filter wrap-up calculations are not performed until after closing the aircraft control loop, and so do not contribute to the delay. The saving is significant because the wrap-up can represent as much as 92% of the total filter load.

Gain Change—Manual gain changing is provided in lieu of automatic gain changing as a function of, say, dynamic pressure. Separate pitch, roll, and yaw gain-select switches on the MAPP, each with four positions, comprise the pilot interface. Selection of a specific gain (or coefficient) parameter is made from a fixed list of 105 candidates, serially numbered from 1 to 105. Each gain is associated (by axis) with a particular gain-select switch, and a maximum of 9 gains can be designated for a given flight. Each gain chosen, with its serial number and four values, becomes part of the PEL. When a gain-select switch is changed by the pilot, the program recognizes the change and the PEL-designated gains associated with that switch axis are changed. For each gain in turn, a small routine implements the change, performing all necessary scaling, recomputing all working registers using that gain, and initializing any filter using that gain.

Erasable Memory Programming—Erasable memory programming provides the only means of modifying the program once the core rope is manufactured. Modification can sometimes be accomplished by breaking into the program flow at a suitable erasable branch point, which must be of the second class as defined above. The procedure is to change the erasable cell contents to point to an unused block of erasable memory and to load executable code into that area (called an Erasable Memory Program or EMP). The final instruction of the EMP returns control to the fixed memory program. The EMP allows some unanticipated problems to be solved by shoehorning suitable code into the program flow.

Erasable Downlist—In Apollo, the identification and specification of telemetered data was done by means of address tables built into the core rope. For a mature design such as Apollo, quantities of interest are well known, and properly can be built into the rope. F-8 DFBW, on the other hand, must offer flexibility for experimental design. Variables and quantities of interest can change from day to day depending on a given flight plan. To accomplish this end, erasable specification of the downlist quantities by means of KSTART tape is incorporated into the Downlink program.

## Preflight Erasable Load Assembly

Flexibility is achieved in the F-8 DFBW despite the hardware status of the core-rope program by providing for a large number of erasable parameters. The aggregate, called the Preflight Erasable Load, consists of three categories: Data words, Downlist Words, and Erasable Memory Program words. The Data words are constants and include loop gains, filter coefficients, nonlinearity parameters, IMU compensation parameters, branch control parameters, and branch control address constants. The Downlist words are address constants that define the quantities to be telemetered. The EMP words are executable code and associated constants.

Early in the program the Preflight Erasable Load and the KSTART tape consisted only of Data words and Downlist words, and were generated by CSDL. But the responsibility for the data values resided with FRC, so generation of the Preflight Erasable Load and KSTART shifted to FRC as the software capability was developed there. However, Erasable Memory Program development was a CSDL function, and the verified and accepted EMP code was incorporated into the KSTART by FRC.

Several unique or extremely helpful features characterize the F-8 Preflight Erasable Load (PEL), and the generation of its KSTART uplink tape, specifically:

- (1) PEL parameters are expressed in conveniently scaled, physically significant engineering units.
- (2) A DFCS initialization routine translates each PEL parameter (units and scaling) into DFCS operational parameters. Factored or ratioed parameters are combined into single operational parameters at this time.
- (3) Comprehensive error checking and diagnostic indicators are built into the KSTART tape generating programs.

Parameters—The basic DFCS parameters are expressed in conveniently scaled engineering units and constitute the erasable load. The DFCS working registers (gains, limit levels, coefficients) are defined so as to minimize computation time where possible. This usually results in unusual scaling, e.g., number of DFCS samples instead of seconds, or DAC bits instead of surface degrees. Other working registers are functions of basic parameters, such as a simple product, or a limit level that is computed from intercept/slope/breakpoint values. Also a working register might contain an address constant, selected from a table in accordance with certain rules. To accomplish the interface between working registers and erasable load parameters, F-8 DFBW utilizes an initialization routine. By having an initialization routine available to translate the working registers, the engineer preparing KSTART tapes, or changing parameters manually via the DSKY during a simulation, can continue to think in basic engineering terms. This is especially important in F-8 DFBW, since much of the development is performed on hybrid simulators

where the DSKY interface is the only practical interface for changing DFCS parameters. By keeping PEL specifications simple and by formulating them in engineering terms for both physical feel and visibility, the possibility for error is greatly reduced. Since programmed and verified initialization software is involved, reliable and complete changes are made quickly by single-parameter data entries even though that parameter exhibits multiple usage.

KSTART Generation—Two off-line diagnostic programs, DOWNDIAG and SHERLOCK, developed by NASA/FRC, contribute significantly to the generation of a highly reliable PEL and its KSTART tape. Operational use of these programs is shown schematically in Fig. 3.

DOWNDIAG checks the erasable downlink list specification against format, opcode, address, and keypunch errors. It punches the Erasable Downlist (EDL) and Downlink Processor (DLP) decks only after error-free input is provided. The DLP deck is used for post-flight or post-simulation downlink processing. The EDL deck is integrated with the DFCS parameter deck for input to SHERLOCK.

SHERLOCK likewise checks against keystroke, octal, and address errors, but more significantly performs comprehensive reasonability checks, e.g., minimum/maximum range or compatibility between related elements. SHERLOCK also extracts filter polynomial roots, checks the stability of poles, and checks zeroes against minimum/maximum ranges. Diagnostic printouts must be answered by corrections to the SHERLOCK inputs, or by signed waivers, before output decks are punched, one for the F-8 All-Digital Simulator at CSDL, and the other for input to KPUNCH, the KSTART tape diagnostic and punch program.

KPUNCH calculates the initialization values for the uplink summation (UPSUM) registers such that with a proper uplinking of the KSTART tape, the UPSUM registers equal 77777 77777 when displayed on the DSKY. Errors generated during uplinking will leave numbers other than 7s. KPUNCH also performs limited diagnostic checking and ultimately punches the KSTART tape, ready for uplinking to the LGC prior to flight.

### F-8 DFBW Software Package

The F-8 DFBW software package can be broken down as in Table 3 (Fixed Memory Allocation), and Table 4 (Erasable Memory Allocation). The DFCS code is by far the largest single item. Extensive fixed memory is used by Display Interfaces (DSKY processing), Interpreter/Executive, and IMU Alignment. Most of this code was transferred directly or with minor change from the LM program for Apollo 14. The Self-Test Self-Check code came from Apollo preflight erasable code. Roughly half (696) of the erasables used are DFCS related, and a significant number (389) belong to the Preflight Erasable Load.

### SOFTWARE PROGRAM CONTROL

The flight software for F-8 DFBW program leans heavily on the experience developed for Apollo. The main difference between Apollo software and other



(previous) software is that the Apollo software had to work perfectly the first time it was used in its real environment. Apollo manned missions had a one-shot nature that required guaranteed performance. To achieve such reliability, management and supervision controls were set up, and have evolved over several years into a system to monitor and check software progress very closely and yet not to create an environment that is oppressive to the creativity, perseverance, and dedication of engineers. The system thus created has been proven in both developmental and incremental phases of software. Man-rated flight software depends on reliability and confidence built up by careful management and supervision controls supported by thorough software verification using real hardware and high-fidelity models in simulation.

### Software Management

A successfully managed software effort must provide:

- (1) Realistic estimates of requirements including manpower, assembly and simulation budgets, memory allocations.
- (2) Efficiency in the development and verification process including non-overlapping testing, effective use of man and machine resources.
- (3) Achievement of milestones on schedule.
- (4) Visibility of the product including developmental status, trouble spots, user-oriented operations and interfaces.
- (5) Flexible and efficient response to design change requests.
- (6) Systematic verification procedures at all module interface levels of testing and performance.
- (7) Reliability of final products.
- (8) Quality performance of final products.

The software management and control system developed for Apollo provided such capability. Its selection for F-8 DFBW was a natural outgrowth of successful prior experience with it. Changes were made, but only when the differing situations indicated a modified approach.

The management and control of flight software is directed toward the timely preparation of two end items: a software program assembly from which the read-only core-rope memory is manufactured, and a software preflight erasable-load assembly from which a KSTART tape is manufactured to initialize the erasable read-write memory. Operational efficiency, performance capability, operational flexibility, and overall reliability are demanded of both the fixed and the erasable-memory assemblies, since they complement each other in terms

of overall performance. Timely availability is likewise a requirement in terms of schedule milestones. Changes and additions to the baseline design must be implemented with the same quality and timely control.

### Organization and Controls

The software organization used by F-8 DFBW is relatively simple. The Project Manager is the customer's contact point. The Project Manager interfaces with the Software Manager, who interfaces with the engineers doing the software design, coding, and verification. Both of the latter interface with Assembly Control, which is responsible for the assembly process. The types of control machinery available to the Project Manager and the Software Manager are as follows:

- (1) Software Specification Document is the product specification to which the software must conform.
- (2) PCR—a Program Change Request, that officially changes the Software Specification (must be signed off by customer, Project Manager, and Software Manager).
- (3) PCN—a Program Change Notice, similar to a PCR but deemed imperative by CSDL (must be signed off by Project Manager and Software Manager).
- (4) Anomaly—a request to fix an error in the program (must be signed off by Project Manager and Software Manager).
- (5) ACB—an Assembly Control Board request, identifies a necessary program change that is not a specification change (must be signed off by Software Manager).

Under Configuration Control, all coding changes and additions must be covered by one of the above forms of approval before the Assembly Control Supervisor will incorporate the code into the assembly.

### Assembly Control

The Assembly Control functions in Apollo were highly structured and very formal for the mainline program assemblies. There was an Applications Programming Development and Testing Group for the two major assemblies. A System Integration Programming Group served for all assemblies, but the major assemblies had separate Assembly Control Supervisors. Finally, the Assembly Control Service Group served all needs.

The software generation process is illustratively simplified in Fig. 4. A coding task is routed to the appropriate programming group for code design. Discussions with the other groups might follow. Completed code is submitted to Assembly Control where it is either accepted for the next revision or returned

for corrections. At appropriate times, the assembly update deck is submitted to make the new revision. The Assembler output is examined by Assembly Control and errors are either fixed or referred back to the coder for rectification. Notification of a good assembly is given to coder/testers who submit simulation test runs. If tests do not work correctly, corrected code is submitted for the next revision. On receipt of good results, a new coding task is begun.

In F-8 DFBW, with a total programming team of about nine people, such structuring was not practical or necessary. Nevertheless the spirit of the Assembly Control process was maintained. One member of the DFBW team was designated Assembly Control Supervisor, but his activities spanned all four of the structured areas as time permitted and activity made necessary. For example, he monitored, coordinated and submitted all assembly changes, maintained the Simulator test packages, published the assembly documentation, maintained and verified IGC System software, coded and verified some Applications code, and participated in Level 4/Level 5 testing. The other team members likewise found their activities spanning the four groups as specific needs came and went, each contributing in areas of greatest interest and ability.

#### Controllable Items

In addition to the main program assembly, there are also other areas where control procedures must apply. These are the Preflight Erasable Load Assembly, Simulator Test Packages, Off-line Program Assemblies, and Erasable Memory Programs.

A Preflight Erasable Load Assembly is associated with each mainline program revision, and consists of data constants, branch-control constants, and address constants that are defined in the mainline revision. The Preflight Erasable Load Assembly is used to generate data and address decks for Simulator test runs and it is essential that these decks be error free.

The Simulator Test Package supports the software testing and verification by providing a common library of test case decks. Functionally the decks cover three categories: program initialization, simulation control, and edit control. Operationally the decks are invoked in suitable configurations at run time by single cards in the user's test deck.

Off-line Assemblies—As the mainline program matures, off-line versions are useful to check out code prior to updating the mainline assembly. Once the design and coding is checked out, a simple transfer of appropriate code is made to the mainline assembly. In F-8 DFBW two examples occurred; one was to check out a major design modification in the BCS downmode logic just prior to Configuration Control, and the other was to create a testing and training tool capable of failing input/output discrettes via DSKY commands.

Erasable Memory Programs—Erasable-memory programming is a tool enabling a limited flexibility for modifying core-rope program flow. A block of code is designed to reside in and operate from erasable memory, and a way is devised to access the code from the existing rope.

## Assembly Control Tools

Assembler—Since the software was not written in a Higher Order Language, a sophisticated assembler was of utmost importance. The Assembler is by far the most powerful tool in the Assembly Control process. The lengthy evolutionary period of Apollo has generated many fine features.

Diagnostic Package—The Assembler diagnoses faulty coding in both basic and interpretive languages. It issues diagnostic messages about references to non-existent variables, multiple definitions, illegal sequences of instructions, improper erasable-bank or fixed-bank references, and many others.

Basic and Interpretive Language—The Assembler recognizes two languages: basic language, and a list-processing interpretive language. The latter permits vector and matrix as well as double and triple precision operations; these are processed by the Interpreter software routines in the LGC. The Assembler recognizes data constants, noun and verb constants, downlink list specification constants, and address constants.

Flexibility of Memory Allocation—Blocks of fixed-memory programming can be referenced to each other so that if a block expands, another block need not be moved to make room for it. Overlapping of program memory is flagged if it occurs. Overlapping of erasable storage (time-sharing), on the other hand, is facilitated by the Assembler.

Program Visibility—The Assembler provides complete mnemonic cross-reference tables, a summary of erasable memory assignments, and maps of both erasable- and fixed-memory storage. All operand references are threaded, allowing rapid eyeball debugging even when the relevant passages are scattered through hundreds of pages. Word count, including a breakdown by functional area, is provided.

Modularity—The Assembler provides the ability to separately assemble and partially diagnose sections of the full program. These can be coded separately and brought together into full programs for verification.

Interface with All-Digital Simulator—The Assembler output includes input information for the All-Digital Simulator, which is useful for simulator initializations, and for simulator run-time diagnostic error detection. The Symbol Table enables the addressing of erasable cells and fixed locations by name, rather than by number which tends to vary from revision to revision as memory layout is modified. Tapes for fixed-memory loading of core-rope simulator can be generated. Constants, bad words (assembler-detected errors), unused words, and coding instructions are distinctively flagged to permit detection of such run-time errors as 'executing a constant' or 'executing from unused fixed memory'. KSTART tapes can be punched directly from the Preflight Erasable Load Assembly as a feature of the Assembler.

## Erasable Memory Map

The limited erasable-memory size of the LGC forced a policy of cell sharing as a means of extending memory capability in Apollo; extensive cell sharing was necessary, more than doubling the erasable complement and resulting in as many as seven distinct usages. An erasable-memory map was used as a bookkeeping and planning tool. The map was looked on as a short-lived necessity, otherwise the cell-sharing process would have been automated. In F-8 DFBW, even though memory cell sharing is limited, the Erasable Memory Map is an especially useful document. A separate map is prepared for each erasable bank by the Assembly Control Supervisor. The primary allocation is identified in the first column, with the overlays defined in the subsequent columns. The map simplifies the problem of assigning multiple use to cells or blocks of cells and minimizes the problem of run-time conflicts between LGC programs. The maps are extremely valuable to the programmer preparing erasable memory code by identifying unused blocks of cells and by aiding in the time-sharing usage of cells.

## Software Development Activity

The software development process, involving all phases of software activity, can be summarized in Fig. 5. All software design is based on written specification. In Apollo, the specification was the seven volume Guidance System Operations Plan. In F-8 DFBW, the Control Laws, backup interface requirements, pilot interface requirements, and data retrieval requirements are prescribed in the Software Specification. The LGC executive hierarchy, service routines, interrupt processors, restart routines, downlink, and all others that came from Apollo are specified by inference as being the same as Apollo. The few changes in this category by rights should be documented by PCRs or ACBs. However the ultimate documentation in this area, as was similarly true in Apollo, is the detailed flowchart. Nevertheless, in the software development, authorization must exist in one of the forms: Software Specification, Program Change Request, Program Change Notice, or Assembly Control Board direction.

Another class of input to the Software Development, shown in Fig. 5, is the Initial Data Load which becomes the Preflight Erasable Load. The load is the cumulative array of values for control law parameters and for other routines' parameters and, as such, is jointly specified by FRC and CSDL. The load is revised and updated to keep pace with the software development.

A third class of input to the software development is the test plans, the most important one being the Level 4 Test Plan. Test plans exist at all levels and are the basis for the level testing. At the lower levels, the plans are informal tools to ensure thorough unit testing by individual programmers. The Level 3 Test Plan and the Level 4/5 Test Plan are carefully documented compendiums of specific tests, and cover all areas of the software. The test plan is reviewed and updated by all concerned; it can be added to at any time to include any overlooked areas.

Continuing in Fig. 5, the software is designed in blocks or units with each being tested before proceeding to the next. Testing at the unit level (Level 1/2) is generally bit-by-bit digital simulation. When a sufficient number of units are completed, the hardware and alarm interfaces are tested as appropriate. These tests generally involve all three simulators: the Digital, Hybrid, and System Test Laboratory. Modular Testing (Level 3) commences in any given area when all units in a given program function are completed, for example, the DFCS Direct Mode in the pitch axis. This level of testing continues until all DFCS modes and capabilities are completed. Since several program areas are developed in parallel, but not all at the same rate, testing at several levels takes place during any given time frame.

When all major programs appear to be essentially completed, Configuration Control is instituted, officially designating the start of Level 4, although limited Interface testing can take place earlier. Subsequent to Configuration Control, all program changes require the careful scrutiny and approval of one or more of the software supervisors, as well as the coding experts in the areas affected. Software Specification changes require a PCR. Level 4 tests are based on the Test Plan, and all incorrect, or unexpected, or incomplete, or anomalous behavior is documented in an anomaly report or a discrepancy report. Discrepancies are software errors detected after Configuration Control, but prior to release-for-manufacture. Anomalies are software errors detected after release-for-manufacture. Verification at Level 4 and above involves exercising the program on the three CSDL simulators, as well as the FRC Iron Bird System. All documented anomalies and discrepancies must be resolved. In some cases resolution of a Hybrid or Iron Bird item requires an attempt to reproduce the behavior on another simulator, or perhaps the Digital, in order to pinpoint the cause. When the cause of a discrepancy or anomaly is identified, an assessment is made to determine: (1) the operational impact when the problem is encountered if the program is left as is, (2) the procedures necessary to avoid or to work around the problem, (3) the coding change necessary to eliminate the problem, (4) the schedule impact of implementing and verifying the coding change. The assessment is documented as a PCR, PCN, or ACB which, if approved, is implemented as a fixed-coding change. Erasable coding is not used at this level for permanent changes. Disapproved PCRs, PCNs, and ACBs become program Notes. Sometimes it turns out that what was thought to be an anomaly, or discrepancy, was caused by a simulator bug, or a test deck error; in which case the problem is fixed and the test is rerun.

When all pending program changes are incorporated and tested at Level 4, and when no unresolved problems remain, the program is ready for release and is declared frozen. A technical review of the Level 4 testing is held (pre-FACI). If, in any areas the testing appears to need reinforcement, then new or additional Level 4 tests are defined. The Level 5 testing consists of re-running all of the Level 4 test decks on the final version. If any new anomalies or discrepancies turn up and are serious enough to require a PCR, the Erasable Memory Program option is weighted heavily against a manufacturing schedule slip. The First Article Configuration Inspection (FACI) is a formal review of all Level 5 testing results, anomaly reports, change requests, program notes, and operational restrictions. The end action of the FACI is the granting of approval to release the rope assembly for manufacturing.

## Flight Support Activity

The Flight Support Activity takes place after delivery of the Manufactured rope modules and centers around Level 6 testing as shown in Fig. 6. The KSTART tape is generated from the Preflight Erasable Load involving the Initial Data Load and any existing Erasable Memory Programs. Evaluation involves careful scrutiny of all parameters, by computer Program and by eyeball, to identify and assess changes from the previous KSTART tape. Additionally, the CSDL evaluation utilizes the Hybrid Simulator, the All-Digital Simulator, and the Systems Test Laboratory hardware installation. The testing is complemented by extensive mission-sequence testing on the Iron Bird Simulator at FRC, and involves pilot training, pilot procedures, and system performance. The test results are presented at the Flight Readiness Review (FRR), and any anomalies resolved, perhaps by modifying the operational envelope. FRR approval is required for flight go-ahead. Following a successful flight to test one DFCS capability, the Initial Data Load can be modified to test another capability, or to change the downlink coverage, and the procedure of Fig. 6 is repeated.

Alternatively, the flight test results can indicate a serious need for a DFCS capability that does not exist in the rope. In this case, a PCR is submitted to request that the capability be developed as an EMP. After assessment, if the PCR is approved, the development and test of the EMP is undertaken as was shown in the previous figure, Fig. 5. When completed, the verified EMP is incorporated into the KSTART tape for Level 6 testing.

## Software Milestones

The development activity is tracked by milestones. Schedule milestones were not treated with the level of formality accorded their Apollo counterparts. Small meetings of one or two technical personnel with management personnel marked many F-8 DFBW events. Nevertheless, schedule milestones were vital to a timely development and verification process. The major milestones are indicated in Fig. 2.

The Preliminary Design Review (PDR) for F-8 consisted of several meetings, each covering a specific area of interest. These were preliminary in the sense that changes were expected as subcontractors and customer had the opportunity to review carefully each other's needs, plans, and suggestions.

The Critical Design Review (CDR) also consisted of several meetings, each covering a specific area in minute detail. The CDRs for the Control System Specification and the Interface Control Document are specific examples.

Level 1, 2, 3 Testing (Unit and Modular testing) allows tracking of units of software in the early stages of development when coding and verification are relatively independent of tight controls.

Configuration Control marks the transition to tightly controlled software configuration and testing procedures.

Level 4 Testing (Interface testing) allows tracking of interfaces between modules of software. Program changes require written approval and all anomalous simulation behavior requires documentation, analysis, and resolution.

Level 5 (Formal testing) allows tracking of software prototype.

First Article Configuration Inspection (FACI) is a formal review of all aspects of prototype software. The final action is the approval of the final assembly for manufacture.

Release-for-Manufacture—Following FACI approval, a weaving tape is generated from the final assembly to be used for core-rope manufacture.

Level 6 Testing (Mission Performance testing) is based on the KSTART tape for the particular flight. Evaluation consists of exercising the KSTART tape on the three CSDL Simulators and on the FRC Iron Bird System.

A Flight Readiness Review (FRR) is conducted prior to each flight. A statement from CSDL is required concerning its review on the Preflight Erasable Load and KSTART tape. The initial FRR had the longest agenda. The review assessed the flight readiness of the primary control system, the backup control system, the flight vehicle subsystems, to name a few. Known anomalies and their avoidance or work-around procedures were discussed. Erasable Memory Programs were explained, both functionally and operationally. The failure analysis studies were reviewed, as well as available documentation. Flight readiness reviews subsequent to the initial flight generally consider the current KSTART tape and any newly applicable areas.

## SOFTWARE VERIFICATION

The software verification process is vital to the preparation of reliable high-quality software. A screening process is employed, whereby code is subjected to many tests representing many different situations. This approach to testing is one of diminishing returns: early tests show up most of the coding errors, but the later tests build confidence in the overall quality of the program assembly. Establishing the proper balance between insufficient and excessive verification testing is a critical task. Indeed, the verification process does not terminate with release-for-manufacture; it continues, in the hope of catching any remaining errors before they show up operationally with unexpected and perhaps dangerous consequences.

The verification process cannot be separated from the assembly control process, at least prior to release-for-manufacture. The ultimate quality and reliability of code depends heavily on the verification process. The attainment of the verification goals involves far more than the execution of high quality object code available near the end of the software development cycle. Facilities are required in the early stages of program development when the code available is of low quality and may not even be executable. In the early stages a benign and cooperative environment is required; it must provide a detailed



visibility into the execution of code. Simplified, but fast-operating environment algorithms are desirable. Extensive diagnostic capability is mandatory, involving both run-time and post-run software packages. As code quality is refined, the environment quality can be updated to include such factors as sensor errors and higher order effects. Ultimately the code should be exercised in a highly realistic environment including as much real hardware as possible.

### Software Verification Facilities

Several distinct facilities were utilized during the DFCS verification process. The complementary nature of their unique capabilities is significant. Each has contributed to the DFCS quality, and by its absence would have affected the development adversely, mainly in terms of schedule, but perhaps even in terms of operational performance. CSDL has utilized the All-Digital Simulator, the Hybrid Simulator, and the System Test Laboratory facilities for the software development and verification activities. NASA/FRC has utilized the analog Stage 1 engineering simulation, the bench lashup Stage 2 hardware integration simulation, and the Stage 3 Iron Bird Simulator for the systems design, hardware integration, design verification, and pilot training/evaluation activities.

Each of these facilities has contributed to the overall success of F-8 DFBW, but certainly the significant contributions to system integration have come from the Stage 3 Iron Bird Simulator. It was on this facility that significant hardware integration problems were first encountered. The Stage 3 piloted simulations gave insight for design-change evaluation. Stage 3 permitted real-time demonstration of failure effects, and permitted engineering preliminary and final design. Stage 3 was used for much supportive software verification and essentially all of the system design verification. For the flight testing, where CSDL's verification role was supportive, the Stage 3 simulation was especially important as the primary design, verification, and training tool.

The All-Digital Simulator (ADS) at CSDL played the significant role in F-8 software design, development, and verification, primarily because of the powerful run-time diagnostic and post-run edit capability, as well as features such as repeatability and snapshot/rollback. Rigidly controlled simulator software provided a stable environment and ensured repeatability.

The Hybrid Simulator at CSDL was a very useful tool during preliminary verification, primarily because of its real-time interactive capabilities. Its role was somewhat diminished because CSDL did not have DFCS design responsibility, which is where the real-time interactive aspects of hybrid simulation can vastly improve the control-system designer's efficiency. However, on two separate occasions, one being the time-critical development period between Stage 2 and Stage 3 simulation, NASA/FRC came to CSDL and conducted basic and detailed design on our Hybrid facilities.

Piloted simulations early in the development phases can improve the overall quality of the end item, especially when schedules are tight. Pilot contributions cover a wide range of experience including such items as human

factors suggestions, functional change requests, performance and handling qualities evaluation, and safety considerations.

The complementary nature of all-digital, hybrid, and hardware integration facilities is important. The ADS provides diagnostic and edit capability plus detailed hard-copy for documentation. The Hybrid Simulator is unmatched in its real-time interactive capabilities for preliminary design, parameter-variation, and sensitivity studies. The hardware integration facility represents the ultimate interface verification tool short of flight test. Here, interfaces are actually mated, often for the first time. Failures can be studied and pilot-in-the-loop evaluations based on a maximum hardware complement can be performed. Each of the design, development, verification, and training tools can play a key non-overlapping role. It is the complementary nature of each facility which should be emphasized and utilized for greatest program efficiency and end-item quality.

A brief description of each of these facilities follows.

CSDL All-Digital Simulator—The Apollo Digital Simulator is a basic tool developed and employed primarily to support the design, development, and verification of Apollo Guidance Computer (AGC) programs. The simulator is entirely digital and consists of a number of programs implemented on a general purpose digital computer. It simulates the operation of the AGC in storage layout, and in detailed arithmetic and logical operation. Consistent with one's objectives, mathematical and logical models ranging from rudimentary to comprehensive may be selected to simulate the hardware and flight environment within which the AGC and its coding operate. For the F-8C, only the rigid body degrees of freedom are mechanized and there is no takeoff or landing capability. The BCS flight control system is not simulated, so controlled flight is possible only in the DFCS modes. The Pilot Action Simulator provides open-loop actions such as stick and rudder deflections, push button and trim switch activity, and DSKY operations. In addition, the simulator has numerous on-line diagnostic features, a snapshot/roll-back capability, and extensive post-run edit capability available. The edit package provides for flexible run-time data storage and for post-run data retrieval. The user has the choice of using standard edit programs or of writing his own. Extensive edit programs for plotting, computational verification, and formatting were developed for F-8 formal verification. Summary printing includes data on DFCS mode changes, timing, and computational delays. Plot variables include numerous DFCS and environmental quantities. Timing data indicating duty cycle and job activity is plotted. A downlink processor edit was prepared to verify proper downlink operation. The simulation system is illustrated schematically in Fig. 7.

The CSDL Hybrid Simulator—The Hybrid Simulator is a combination of selected flight hardware used in concert with analog and digital computers to provide real-time simulated flight. The flight hardware consists of an LGC computer, a DSKY, and the coupling data units. The LGC memory is replaced by a Core Rope Simulator (CRS), which provides a complete erasable memory as well as helpful features, such as the ability to monitor and change location contents, to stop at a location address, or to single-step the program. The IMU

is simulated with special-purpose electronics. Elements needing precision of storage, as the trajectory dynamics, the aerodynamics, and the rotational transformations, are simulated in an XDS 9300 digital computer. The high-frequency actuator dynamics, the BCS loops, and some discrete logic are simulated on the analog computer. The algorithms for BCS control and BCS downmode-trim initialization are simulated, but the cross-channel comparator and the hydrologic subsystems of the F-8C are not modelled. Also, provision is not made for a parking, landing, or takeoff capability. A minimal cockpit uses the Apollo three-axis rotational hand controller in place of stick/pedal controls. Cockpit instrumentation includes artificial horizon, altitude, airspeed, rate-of-climb, % thrust, g, angle of attack, and a mockup Mode And Power Panel for real-time man-in-the-loop simulations. Strip-chart recordings and initialization printout are the only hard-copy output. The Hybrid Simulator runs in real time to allow man-in-the-loop testing, on-line debugging, and flexibility in verification procedures. The LGC can function alone or with the Simulator providing an environment; in the former mode it is available independently of the availability of the hybrid facility. Reproducibility is not in general possible, but this is an advantage in that a realistic randomness is introduced into the testing.

CSDL System Test Laboratory—The System Test Laboratory (STL) is an Apollo hardware integration facility. A real IMU interfaces with the LGC, CRS, and DSKY. Uplink and downlink are operational. Channel inhibit discretely can be set or cleared manually and independently. The aircraft and BCS systems are not simulated. A trace capability is available via the Apollo CORONER and off-line processing; this is the only hard-copy output from this facility.

NASA/FRC Stage 1 Simulator—The Stage 1 Simulator was a preliminary design tool used to develop the flight control system specification equations. Simple analog models and sample-and-hold networks were utilized. Linear analysis based on continuous and sample-data control system design, using root locus and w-plane techniques, provided backup for the simulation effort.

NASA/FRC Stage 2 Simulator—The Stage 2 Simulator was a hardware integration and preliminary design evaluation facility. Breadboard lashup of major hardware components was first performed here. The LGC, the Program Analyzer Console (PAC, equivalent to the CRS), DSKY, IMU Gimbal Angle Simulator (GAS), and CDU package were involved. Aircraft and aero-surface servo actuator dynamics were modelled on a small analog computer. A rudimentary version of the DFCS and Operating System software participated.

NASA/FRC Stage 3 Simulator—The Stage 3 (or Iron Bird) Simulator is an F-8C airframe that includes all key hardware in the configuration of the flight article, including the pallet mounting of the LGC computer, IMU, and CDUs. The BCS electronics, power supplies, and hydraulics are flight-article type systems. The manufactured core-robe or PAC software can be used as the LGC memory. Simulated trajectory dynamics and aerodynamics permit closed-loop simulations using the GAS. Simple external visuals, sideslip angle and horizon line with sky/earth differentiation, are provided on a TV screen mounted on the aircraft nose. Access to LGC and flight control system variables is by means of downlink with post-run editing or by DSKY display.

## Software Verification Testing

It is difficult to separate software development and software verification since both go hand in hand throughout the development phase. To consider software verification it is necessary to consider software development. Generally speaking, there are two categories of software design changes that contribute to program construction.

- (1) Developmental changes - these are creation of a new program or a new routine, or extensive changes within an existing program or routine.
- (2) Incremental changes - these are modifications to existing code that cause small alterations and repercussions.

Clearly, a Developmental change has a major impact on the existing program and requires an extensive testing approach to assure that the new code works properly and does not interfere with other existing coding. It is equally clear that an Incremental change has a minor impact on the existing code and requires a localized testing approach. This is sort of by definition. However, it is not always clear into which of the two categories a given software change should be placed. Classification is a difficult problem and requires experience and thorough knowledge of the programs. For example, a one word change could require extensive testing if that word were, say, a sample period affecting event timing. On the other hand, the replacement of one Boolean relationship by another, involving perhaps 30 words, could be local in effect and require only local testing. Thus, the full arsenal of testing is brought to bear on Developmental software, while a subset is used for Incremental software.

Developmental Software Testing—In order to test out developmental changes, the six official levels of testing are normally performed. These are Unit testing (Levels 1 and 2), Modular testing (Level 3), Interface testing (Level 4), Formal testing (Level 5), and Mission Performance testing (Level 6). The majority of the F-8 DFBW programming effort falls into the developmental category, as exemplified by the flight control coding, input/output processing, ground test programs, and special routines. Design changes that occur late in the development cycle are often accorded the Developmental treatment. Erasable Memory Program design is also in this category, although there have been exceptions.

Incremental Software Testing—Incremental changes require adequate testing to assure that all paths in the program affected by the change are exercised. This may necessitate designing new tests for specific code changes. Incremental testing involves some combination of Unit testing, Modular testing, and Interface testing. Since all incremental changes become part of the program rope, they are automatically subjected to Level 5 and Level 6 testing.

There have been a number of incremental changes in F-8 DFBW. Initially, much of the software (about 60%) came from the Apollo Lunar Module Program. Many areas of the code required minor incremental changes to meet F-8C requirements. Late in the development cycle, especially as the release-for-manufacture date approached, changes even to flight control code can often be treated as incremental, especially if significant Level 4 interface testing has already been completed.

Some Erasable Memory Programs have been classified as Incremental. In one case, two lines of code were added to an existing EMP to create the one-pulse rudder pedal deadband. The other case was a preflight checkout program. These have received minimal Level 4/5 testing. Conversely, other EMPs involved significant design changes deeply imbedded in interface or systems code: parabolic shaping of stick inputs, or restart-triggering of BCS downmoding. These have received significant Level 4/5 testing, being developmental in nature.

Special Testing—There are a number of special tests deserving of mention that establish confidence in the flight software mainly by failing to find a fault rather than by exhaustively proving every possibility. This approach is in general true when the number of ways to exercise the code becomes unwieldy. The fact that interaction between the Executive, interrupt processors, and service routines falls into this category can be overlooked. A specific example is restart testing where a large number of artificially generated asynchronous time-triggered and location-triggered interrupts exercise the restart protection mechanism. Stress testing involves testing operational sequences under abnormal conditions. Potential anomaly testing attempts to duplicate the event sequences which led to questionable behavior on another hybrid facility. Hybrid testing occasionally encounters unexpected behavior that is usually a hardware problem, but can be a software problem. If a problem is found, digital testing gives conclusive evidence. Alternatively, if no problem is found, a measure of confidence is restored.

An 'eyeballing' effort was performed on the F-8 DBFW assembly just prior to release. Experienced Apollo programmers were assigned sections of the code to eyeball for errors, based on their accumulated experience. Several errors were uncovered, although off-nominal operational procedures would have been needed to encounter difficulties. The fact that errors were found gave weight to the effort as a worthwhile task. The absence of any serious errors, and the minimal number of errors encountered, added to the confidence level being built by the verification process.

#### Input and Output Discrete Failure Effects

A formal failure effects investigation was conducted late in the development cycle by CSDL and by other systems contractors. All interfaces were studied for fail-on and fail-off effects. Engineering analysis was the primary investigative tool, but simulated failures were utilized whenever pilot-in-loop problems were expected. To this end, a special version of the mainline program was created for the Iron Bird and was given the capability to fail any selected input/output discrete in the off-state or on-state. Failures were introduced during Iron Bird piloted simulations by a test engineer at the DSKY. The capability enabled pilot training in recognition and recovery procedures.

An important conclusion of the failure analysis is that such studies should be initiated early in the preliminary design phase so that failure effects can be recognized and avoided by careful design of hardware, software, and interfaces. Early recognition leads to design changes that often can be incorporated at no additional cost, whereas late recognition can be quite expensive.

## Erasable Memory Programs

The concept of an Erasable Memory Program only has application in reference to a fixed memory computer when the capability to manufacture a new fixed memory is no longer available. Certainly, as long as the capability does exist, the redesign of a portion of the program or the inclusion of a new portion poses no particular problem even in a relatively mature program. In F-8 DFBW for example, the result of early Iron Bird simulations uncovered a hardware interface problem in that the anti-dropout filter in the CDU error counters interfered with restart recovery. Since the software was still under development, a straightforward redesign of the restart recovery routine was undertaken, including redevelopment and verification. On the other hand, when the ability to remanufacture the rope memory is gone, it is necessary to resort to an artifice, like erasable memory programming, if any change is to be incorporated into the program flow. If, however, one is dealing with a programmable memory computer, then post-release software changes are treated the same as pre-release software changes. The purpose of this section on EMPs then is to illustrate by example that sufficient cause for software changes can and will arise after program release, and to describe the F-8 DFBW experience.

Some of the late Stage 3 Iron Bird discoveries were not compatible with software development schedules, bound as they were by the anticipated shutdown of the core-rope manufacturing facilities. Erasable memory programming and major hardware changes were required instead. For example, piloted simulations in early 1972 indicated pilot-response problems with certain computer failures. The work-around concept was straightforward and a software change could have been made, except that the DFCS was no longer software; core-rope manufacture was under way. Fortunately, an Erasable Memory Program (EMP-001, Restart Downmoding to BCS) could do the job, so remanufacture was not necessary. However, the design and especially the verification tasks were much tougher for the EMP than they would have been for the fixed-memory equivalent, a characteristic of most erasable memory programming. Nevertheless, the flexibility provided by last-minute software changes represents a major selling point for digital flight control.

Design changes to minimize the effects of stick/pedal input quantization were not formalized until after the first flight. Hardware changes had been made earlier, prior to core-rope manufacture, but these proved to be inadequate. Again, an Erasable Memory Program (EMP-004, Parabolic Stick Shaping) provided an acceptable approach, but the fixed-memory equivalent would have been easier to design, develop, and verify. Also, the DFCS computational burden would have been lower with the equivalent fixed memory code, and operational aspects would have been simpler.

Problems do not always show up during the systems analysis and preliminary design phases, no matter how detailed the activity, but instead crop up during the hardware integration phase, or even worse, conceal their identity until the flight test phase. F-8C, during high-q flight for example, encountered a single-pulse null shift in the output from the pedal LVDT, which supplies the rudder pilot commands to the DFCS. The phenomenon apparently has something to do with

airframe distortion at high-q flight conditions. Neither the Stage 3 Iron Bird Simulator nor preliminary analysis models could indicate such a phenomenon. In this case, the hardware problem of rudder bias shift was eliminated by software, by inserting a one-pulse deadband (EMP-007, Single-pulse Pedal Deadband). There is a real motivation for a flight test phase, however brief, between the prototype and production software.

#### CONCLUDING REMARKS

The F-8 DFBW is an experimental digital fly-by-wire testbed flight control system, implemented with Apollo off-the-shelf hardware. Existing off-the-shelf software and software control techniques were dictated by hardware as well as manufacturing schedule limitations. Software design was bottom-up. Time-efficient code was important because of LGC speed. (Some of the techniques discussed would not be applicable for a modern, faster, all core computer.) Despite the LGC fixed memory, post-manufacturing design changes to the Specification were possible through Erasable Memory Programs. Proof of the benefits that accrue from good software control and from careful and thorough verification testing is evidenced by the F-8 DFBW flight test program results: In a year and a half, 42 flights, totaling 58 hours of flight time, were made successfully without any DFCS inflight software failures or performance surprises.

#### REFERENCES

The author has made generous use of References 1 and 2. Apollo hardware details are not included but can be found in Reference 2 and Reference 3. Supportive use was made of References 4, 5, and 6.

1. Engel, Albert G. Jr.,: F-8 Digital Fly-by-Wire Software Control/Management, E-2749, Charles Stark Draper Laboratory, Cambridge, Mass., February 1973
2. Engel, Albert G. Jr.,: F-8 Digital Fly-by-Wire, Some Observations, E-2739, Charles Stark Draper Laboratory, Cambridge, Mass., January 1973
3. Miller, J. E., editor: Space Navigation, Guidance and Control. AGARDograph 105, August 1966
4. Hamilton, M. H.: Management of APOLLO Programming. Mission Program Development Note 18, Charles Stark Draper Laboratory, Cambridge, Mass., May 1971
5. Johnson, M. S. and Griller, D. R.: MIT's Role in Project Apollo, Volume V, The Software Effort, Charles Stark Draper Laboratory, Cambridge, Mass., July 1971
6. David, S. S., editor: Users Guide to the Apollo Digital Simulator, Charles Stark Draper Laboratory, Cambridge, Mass., April 1972

TABLE 1

## APOLLO HARDWARE USED IN F-8 DFBW

LGC	-	LM Guidance Computer (approximately 2k of erasable and 36k of programmable fixed core-rope memory; programmable hardware-interrupt and software-executive systems; hardware restart logic, etc.).
DSKY	-	(LM) Display and Keyboard (three 5-digit-plus-sign display windows; miscellaneous warning lights; keyboard including 0 through 9, +, -, PRO (proceed), ENTR, CLR (clear), VERB, NOUN, etc; the DSKY is the computer/astronaut or computer/ground crew interface).
IMU	-	Inertial Measurement Unit (a three-gimballed gyroscopically-stabilized platform for the PIPA accelerometers; gimbal angle resolver and PIPA signals ultimately interface with the LGC; several platform alignment techniques are under LGC software control).
CDU	-	Coupling Data Unit (for analog-to-digital conversion of IMU gimbal angle indications; for digital-to-analog conversion of LGC computer outputs; for control of IMU moding; includes failure detection; used to derive body axis angular rates).
PIPA	-	Pulsed Integrating Pendulous Accelerometer (three mutually-perpendicular contact-acceleration-sensing and incremental-velocity-indicating devices located on the IMU stable member, with a direct LGC interface; used to derive body axis normal and lateral acceleration).
PSA	-	Power and Servo Assembly (power supplies, amplifiers, etc., for inertial subsystem).
PTA	-	Pulse Torque Assembly (input/output processing for inertial subsystem).



TABLE 2

HARDWARE UNIQUE TO F-8 DFBW

MAPP	-	Mode and Power Panel (computer and IMU power control, auto-pilot gain and mode select/indicators, warning indicators, etc.).
IFB	-	Interface Box (junction box containing an Apollo DAC stick/pedal comparators, special amplifiers, etc.).
BCS	-	Backup Control System (triplly-redundant stick/pedal to aerosurface open-loop control, with trim, hydrologic comparator; cross-channel comparator; etc.).
DLC/IFR	-	Downlink Converter/Inflight Recorder (100 word-pair list every 2 seconds on a 20ms interrupt; recording on FM tape for post-flight processing/review).
GSE	-	Ground Support Equipment (the Apollo Program Analyzer Console (PAC) for simulating LGC hard-wire rope memory; the Uplink Converter (ULC) for preflight erasable loading and for DSKY-type program control via tape; the Ground Test Cart containing downlink converter/ground recorder, miscellaneous switches and indicators; etc.).
SPCC	-	Servo Pressure Control Console (PRI select/indicators for each axis; servo pressure switches and indicators for each BCS servo-valve and for PCS servo-valve pairs; each switch has three positions: OFF which disables that valve, AUTO which enables that valve, and MAN which overrides any automatic moding and locks that valve into the active state).
CCS	-	Coolant Control System (coolant for IMU, computer, etc.).

TABLE 3

## F-8 DFBW FIXED-MEMORY ALLOCATION

F-8 DFBW Flight Control System (total)	5586
Body Rate/Acceleration Feedback	320
Generalized Feedback Filters	1930
Pilot Stick/Pedal Processing	168
Control Loop Equations	1178
Channel Monitor Routine	523
Gain/Mode Change Routine	985
Initialization/Restarts/Miscellaneous	482
Ground Test Programs/Extended Verbs	768
Self Test/Check	1436
Fresh Start/Restart/V37/etc.	853
Display Interfaces/Pinball/etc.	3578
Interpreter/Executive/Waitlist/Downlink/Uplink/etc.	3830
IMU Alignment, Compensation, and Tests/T4RUPT	3263
TOTAL F-8 DFBW FIXED-MEMORY USED	19314
TOTAL LGC FIXED-MEMORY (36 FBANKS AT 1024)	36864

TABLE 4

## F-8 DFBW ERASABLE-MEMORY ALLOCATION

Preflight Erasable Load (total)		389
F-8 DFBW Flight Control System	169	
IMU Compensation/Alignment	33	
Erasable Downlink List	100	
Erasable Memory Programming (EMP-001,4,7)	87	
F-8 DFBW Flight Control System Working Registers		321
Extended Verbs/Ground Test Prog/Miscellaneous		50
Self Test/Check		263
IMU Alignment/Perf Test/Ops Test		17
Uplink/Downlink		32
Display Interfaces/Pinball/etc.		56
Executive/Waitlist/Service/Centrals/etc.		468
TOTAL F-8 DFBW ERASABLE-MEMORY USED		1596
TOTAL LGC ERASABLE-MEMORY (8 EBANKS AT 256)		2048

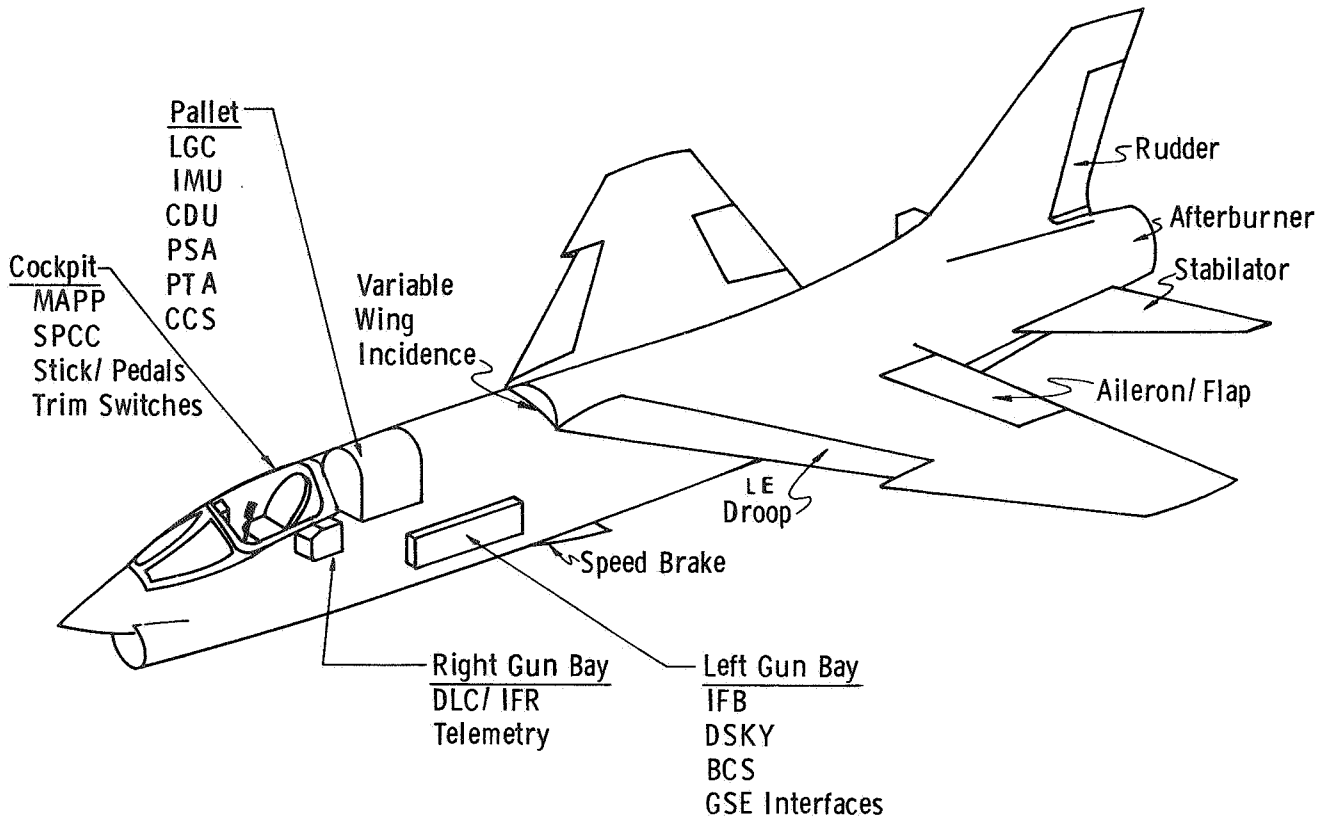

Fig. 1. F-8C DFBW Aircraft and Hardware

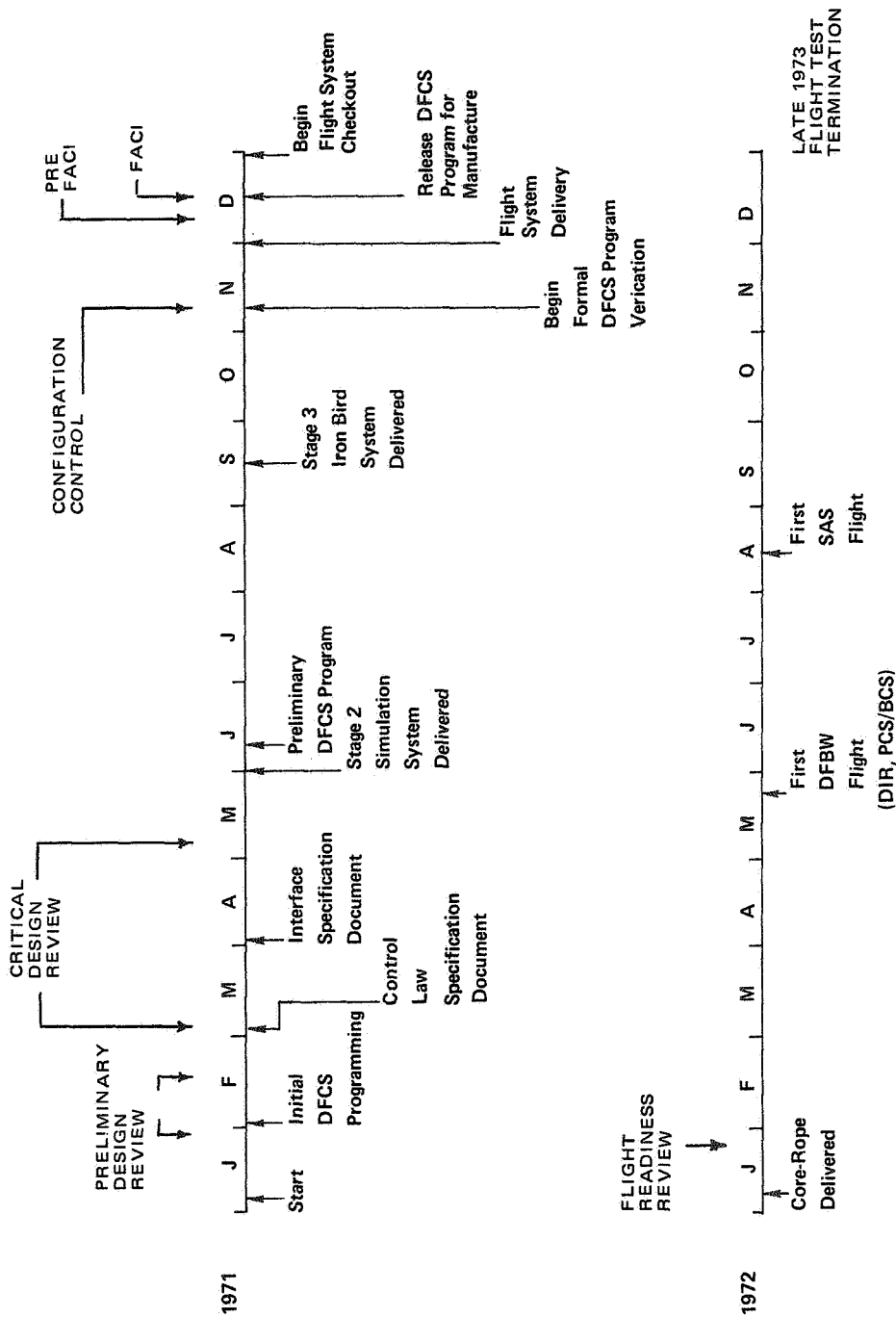

Fig. 2. F-8 DFBW Chronology

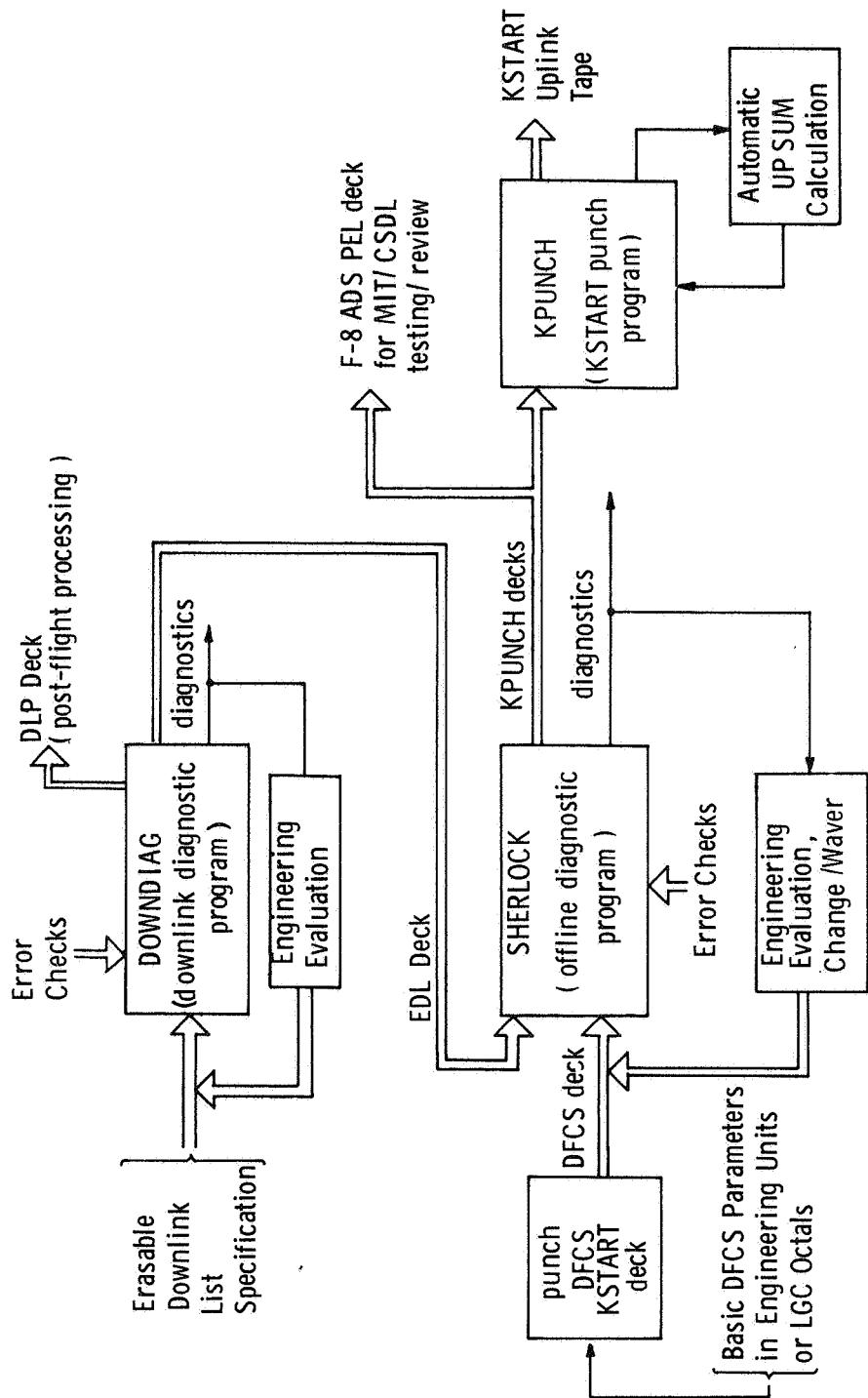

Fig. 3. KSTART Preparation

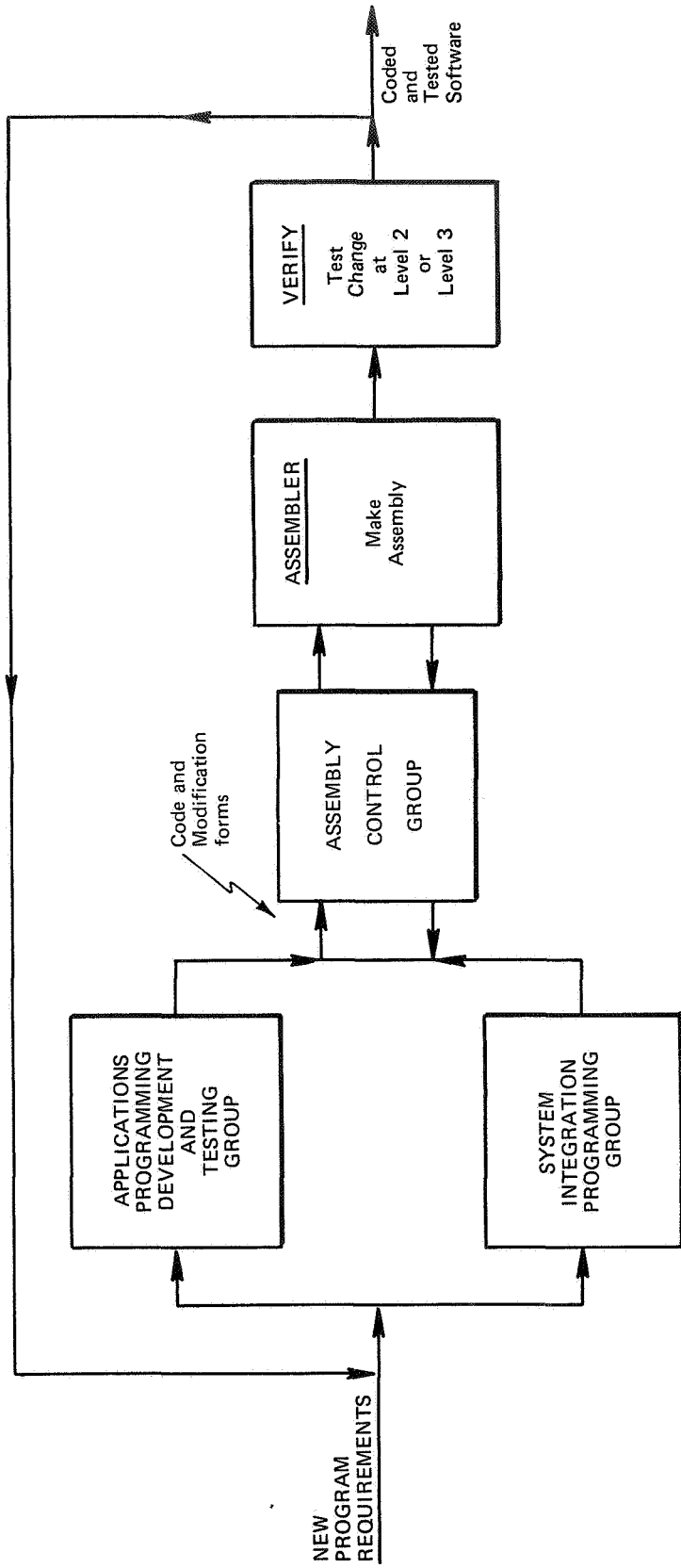

Fig. 4. Program & Assembly Control Activity





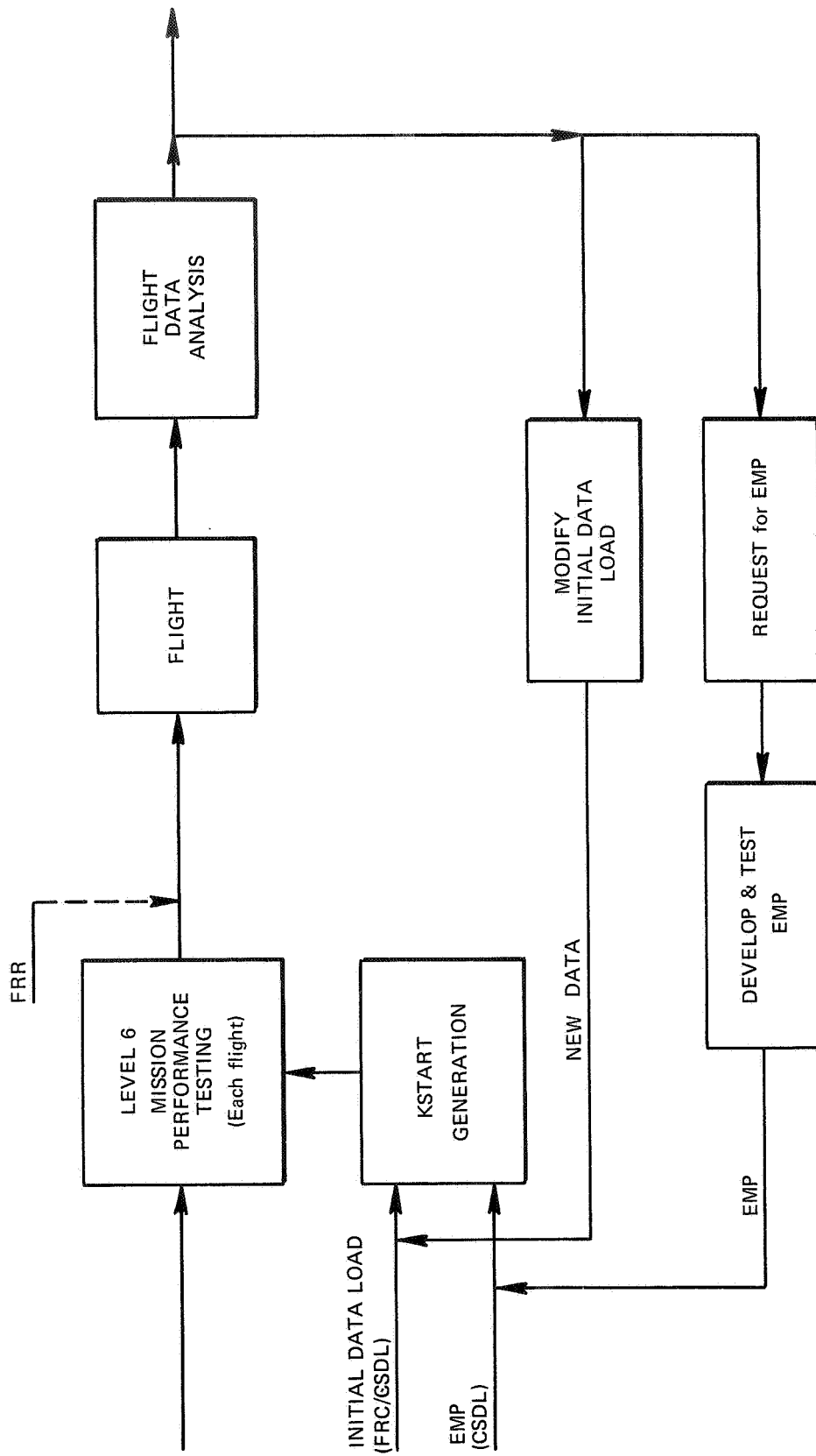

Fig. 6. Flight Support Activity

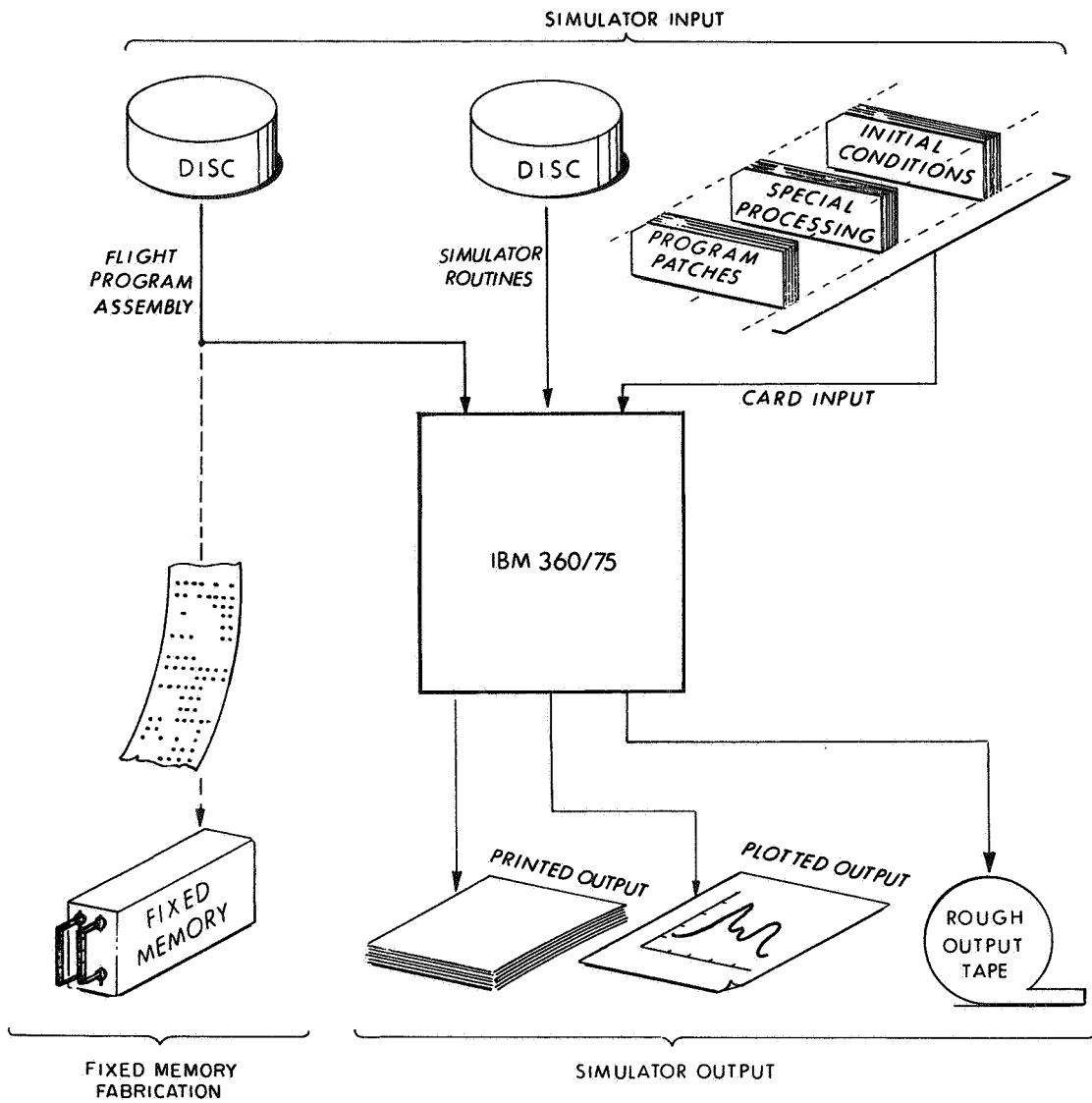

Fig. 7. Simulator System Schematic

## 6. FLIGHT TEST EXPERIENCE WITH THE F-8 DIGITAL FLY-BY-WIRE SYSTEM

Kenneth J. Szalai  
NASA Flight Research Center

### SUMMARY

Flight test results of the F-8 digital fly-by-wire (DFBW) control system are presented and the implications for application to active control technology (ACT) are discussed. The F-8 DFBW system has several of the attributes of proposed ACT systems, so the flight test experience is helpful in assessing the capabilities of those systems. Topics of discussion include the predicted and actual flight performance of the control system, assessments of aircraft flying qualities and other piloting factors, software management and control, and operational experience.

### INTRODUCTION

In May 1972 the flight testing of the F-8 DFBW aircraft began. This aircraft, which used Apollo guidance and navigation system hardware, was the first to rely on a DFBW system for primary flight control. The design and development of the F-8 DFBW control system are described in references 1 and 2 and paper 2. This paper presents the major flight test results for the control system. A detailed description of the system's software development and verification is given in paper 5, and the backup control actuation systems are described in paper 3.

The primary objectives of the flight tests were to evaluate the performance of the digital flight control system and to acquire operating experience with it. The program also served to determine whether the long-advertised advantages and capabilities of DFBW control systems could be realized. Many of these advantages, such as software flexibility, system reliability, and computational ability, make a DFBW system a logical candidate for active control technology applications. The F-8 DFBW control system had characteristics in common with systems proposed for ACT applications. Specifically, it was a highly reliable, full authority system that was committed for use from the first takeoff and landing. An analog control system was the only backup to the DFBW system. The mechanical controls of the basic F-8C airplane were removed before the first flight.

This approach parallels that taken toward the development of an active control system, both in terms of the importance attributed to the design of the control system and the reliability and management of hardware and software, and in terms of the requirement for detailed preflight testing. This paper emphasizes the aspects of the flight test program that relate to the broader considerations of an active control system.

## SYMBOLS

$a_1, a_2, a_3, b_1, b_2, b_3,$	digital filter coefficients
$C^* = n_Z - \frac{V_{co}}{57.3g} q, g$	
$G(s)$	general s-plane filter
$G(w)$	general w-plane filter
$G(z)$	general digital filter
$K$	general gain constant
$K_{C^*}$	$C^*$ feedback gain, deg/g
$K_p$	roll rate feedback gain, deg/deg/sec
$K_q$	pitch rate feedback gain, deg/deg/sec
$K_r$	yaw rate feedback gain, deg/deg/sec
$L_{\delta_a}$	roll acceleration due to aileron deflection, deg/sec <sup>2</sup> /deg
$M$	Mach number
$M_{\delta_e}$	pitch acceleration due to elevon deflection, deg/sec <sup>2</sup> /deg
$N_{\delta_r}$	yaw acceleration due to rudder deflection, deg/sec <sup>2</sup> /deg
$n_Z$	acceleration along positive Z-body axis, g
$p$	roll rate, deg/sec

$q$	pitch rate, deg/sec
$r$	yaw rate, deg/sec
$s$	Laplace transform variable
$T$	sample period, sec
$V$	velocity, KIAS
$V_{co}$	crossover velocity, m/sec
$w$	sampled-data system frequency domain variable
$z$	sampled-data domain transform variable
$\Delta$	incremental change
$\delta$	general surface command, deg
$\delta_{a_p}$	pilot roll stick deflection, cm
$\delta_e$	horizontal stabilizer deflection, deg
$\zeta$	damping ratio
$\theta$	pitch attitude, deg
$\tau_{r_{eff}}$	effective roll mode time constant, sec
$\varphi$	roll attitude, deg
$\psi$	heading angle, deg
$\omega$	natural frequency, Hz

Subscripts:

$d$	Dutch roll mode
$n$	current sample
$n-1$	last sample
$p$	pilot
$sp$	longitudinal short period mode

ss	steady state
Z	component along aircraft Z-body axis in positive (down) direction
$\hat{(\ )}$	derived quantity ( )

#### ABBREVIATIONS

ACT	active control technology
A/D	analog to digital
CAS	command augmentation system
D/A	digital to analog
DFBW	digital fly-by-wire
DSKY	display and keyboard
KIAS	knots indicated airspeed
PCM	pulse code modulation
PIO	pilot-induced oscillation
SAS	stability augmentation system

#### CONDUCT OF FLIGHT TEST PROGRAM

Figure 1 illustrates the nature and sequence of the phases of the flight test program. The first three flights were made by using the proportional control, or direct, digital mode. The fourth flight culminated in a landing during which three-axis DFBW stability augmentation was used. The evaluation of the DFBW control system progressed rapidly from then on, and by the eighth flight all modes had been flown. The airplane was then evaluated in a variety of tasks, including ground-controlled approaches, gunsight tracking, mild aerobatics, and formation flight. The latter portion of the flight program concentrated on flying qualities assessments by additional pilots and on an evaluation of a minimum-displacement side stick that operated through the backup control system only (paper 3). In total, 58 hours were accumulated by six pilots during 42 flights.

The F-8 DFBW system was flight tested within the flight envelope shown in figure 2. Most of the closed-loop evaluations were made at speeds between 250 knots indicated airspeed (KIAS) and 400 KIAS and altitudes from 6000 meters to

10,700 meters. Tests at low speeds (below 200 KIAS) were made with the variable-incidence wing of the F-8C airplane in the up position. Pilot ratings were given in accordance with the Cooper-Harper scale (ref. 3).

All flights were conducted during the daytime under VFR conditions. They averaged 80 minutes in duration. Each flight was monitored in a control room in which 36 airplane parameters were displayed. In addition, duplicates of the pilot's mode panel and servo status panel showed the state of the fly-by-wire control system. All parameters were telemetered from the aircraft's pulse code modulation (PCM) data acquisition system.

### CONTROL SYSTEM PERFORMANCE

The digital flight control system consisted of pilot-selectable modes in each axis. The mode panel layout is described in paper 2. The available modes are shown by axis in the table below:

		Axis		
		Pitch	Roll	Yaw
Modes available	Direct	Direct	Direct	
	SAS	SAS	SAS	
	CAS	Test	-----	

The direct mode, which had no augmentation, and a stability augmentation system (SAS) mode were provided in each axis. A command augmentation system (CAS) mode was also available in the pitch axis. The roll test mode was used to facilitate comparisons between various SAS mode configurations. Block diagrams of the digital control modes are shown in figures 3(a) to 3(c).

#### Direct Mode

The direct mode provided proportional control with no augmentation. Figure 3(a) shows the direct mode mechanization, which was similar in all axes. Analog-to-digital (A/D) quantization of the stick outputs, effective quantization on trim due to sample rate, and digital-to-analog (D/A) output quantization are aspects of digital flight control that were apparent in this mode. Linear and nonlinear stick shaping

were used during the flight program. In the pitch axis, linear and parabolic shaping were used (fig. 4). The Apollo A/D interface allowed a maximum of 45 quantization levels for full stick or pedal deflection in one direction. The Apollo computer D/A converter output quantization, which had  $\pm 384$  levels, was approximately an order of magnitude finer than the stick A/D converter. The linear gearing mechanization resulted in a quantization level of  $0.59^\circ$  of horizontal stabilizer deflection when full pitch control authority was retained. During early flights, various linear gearing gains were evaluated. Table 1 summarizes the pitch quantization effects found with linear gearing. The threshold of quantization detection appeared to be from 0.15g to 0.2g and 1.2 degrees per second to 1.5 degrees per second of peak pitch rate. Figure 5 shows an example of the thumping that the pilot detected at 365 KIAS as he attempted to increase pitch rate smoothly. This small airplane excitation was characteristic of the quantization effect in the pitch and roll axes resulting from control surface actuator response to staircase commands.

The parabolic stick shaping resulted in a nonlinear quantization. The step size is shown in table 2. This shaping greatly improved the fine pitch control of the airplane, while retaining nearly full stabilizer authority. With this mechanization, pilots reported that quantization was not apparent at speeds up to approximately 400 KIAS. In the roll axis, stick quantization had to be reduced by changing the linear gearing about the center stick position. The initial value of  $1.04^\circ$  of total aileron command was changed to  $0.36^\circ$ . This reduced the minimum commanded roll rate from 8.32 degrees per second to 2.90 degrees per second at 250 KIAS and yielded acceptable roll control around trim. The only noticeable effect of quantization in the yaw axis was in random 1-bit commands that were observed at 400 KIAS. Lateral acceleration peaks of 0.03g due to 1-bit or  $0.38^\circ$  rudder surface commands were observed. This problem was corrected by writing software in erasable memory to allow a 1-bit deadband in the rudder pedal command. No other rudder pedal quantization effects were seen.

It should be noted that the  $\pm 45$  quantization steps available represented less than a 6-bit A/D conversion. A 12-bit (11 bits plus sign) A/D capability is available today. This yields a resolution nearly 50 times as fine as that in the F-8 DFBW system. At the most sensitive F-8C flight condition, which was Mach 0.86 at sea level, a 12-bit A/D interface would have allowed digital commands as small as 0.001g, assuming linear gearing and full surface authority. Therefore it is safe to assume that the quantization effects of a modern A/D interface would be negligible and undetectable by the pilot.

Quantization of pilot trim inputs due to sample rate also became apparent in the flight program. In the F-8 DFBW mechanization, trim command discretizes were sampled every 90 milliseconds. Based on the pitch trim rate value of 1.25 degrees per second, the minimum software command was  $0.11^\circ$ . This command is nearly twice as coarse as the D/A converter quantization steps of  $0.069^\circ$  for the horizontal stabilizer. This effective trim quantization was a factor in making precise trim of the F-8 DFBW aircraft difficult at a target speed and altitude.

The pitch trim discrete inputs should have been sampled at the major cycle sample period of 30 milliseconds, which would have resulted in a trim quantization of  $0.0375^\circ$ . This would have taken full advantage of the output D/A quantization. This



points out the need to sample beep trim discrete inputs at a high enough rate to yield acceptable output quantization. In some cases, trim discretizes may have to be sampled at rates higher than the major cycle sample rate, if fine trim resolution is required.

### Stability Augmentation System Mode

The nominal SAS configurations flown are shown in figure 3(b). Body axis rate was estimated by filtering the transformed inertial attitude from the Apollo inertial platform. Compensation filtering and gain were placed in the feedback path. There was an aileron-to-rudder interconnect in the yaw SAS mode only. The stick and trim processing were identical to those in the direct mode. A rate reasonability check was applied to the final command, and an automatic transfer to the direct mode resulted if the reasonability threshold was exceeded.

The digital SAS modes operated as expected. This is important from the point of view of the sampled-data design process. The acceptance of digital control systems depends in large part on the ability to predict system performance accurately.

The digital SAS loops were designed by using sampled-data analysis methods, especially the z-plane root locus method. The linear system model used in the pitch axis is shown in figure 6. An ideal pitch rate signal was assumed. At first, the rate estimation filter that acted on pitch attitude was used in the model, but the resulting pitch rate signal was found to be nearly identical to that for the ideal case at the F-8C short period frequencies. Neither the highly nonlinear A/D conversion of gimbal angles nor the axis transformation steps were modeled. Four symmetrical bending modes were included in the analysis.

The z-plane root locus for the pitch SAS mode without lead-lag compensation is shown in figure 7(a). A lead-lag filter was designed to improve the performance of the pitch rate loop in increasing the short period damping ratio. A w-plane frequency response was used to select the compensation root locations. The w-plane compensation,

$$G(w) = \frac{w/0.1 + 1}{w^2/0.16 + w/0.286 + 1}$$

was transformed to the z-plane by  $w = \frac{z - 1}{z + 1}$  and yielded a discrete filter,

$$G(z) = \frac{1.023(1 + z^{-1})(1 - 0.818z^{-1})}{1.0 - 0.976z^{-1} + 0.349z^{-2}}$$

The root locus for the compensated system is shown in figure 7(b). Higher short period damping ratios were achieved by using the lead-lag filter, as one would expect in a continuous system. A comparison between the predicted effects of the

compensation filter and those measured in flight is shown in figure 8, where the increment in short period damping ratio is shown for three flight conditions. The sampled-data system prediction is good.

The improvement in airplane response with the pitch SAS is evident in the flight time histories in figure 9. Figures 10(a) to 10(c) show a comparison of predicted with measured damping in the three airplane axes. Agreement is good for the longitudinal short period (fig. 10(a)) and Dutch roll (fig. 10(b)) modes. At low gains, rate estimation quantization and actuator friction restricted surface motion at the angular rates tested, and, as a result, the SAS loop was less effective.

The flight performance of the digital roll SAS mode is illustrated in figure 10(c). Since the roll rate response that resulted from a step lateral stick command was contaminated slightly by the Dutch roll, an effective roll mode time constant corresponding to the time between the initial roll rate response and the time when 63 percent of steady state was achieved was used. Yaw SAS was engaged on all runs to reduce the Dutch roll contamination. The predicted trend, which was for decreasing roll mode time constant with increasing roll SAS gain, is clear, although a bias of approximately 0.05 second is apparent. One factor that contributed to this bias was the nonideal pilot step input, which resembled a rapid ramp. This resulted in a slightly higher than predicted effective time constant, since the predicted value was based on a perfect step input.

To further evaluate the sampled-data analysis method, the pitch rate feedback gain was increased in flight until the compensation root approached neutral stability. Figure 11 shows the z-plane root locus prediction of the neutral stability point to be in good agreement with the flight-measured results.

The SAS modes also operated well at low speeds. Pitch SAS results are shown in figure 12(a). A washout filter was designed for low speed operation in the s-plane as

$$G(s) = \frac{s}{s + 1}$$

The discrete washout filter formed by using the bilinear transformation for real roots was

$$G(z) = \frac{0.98522(1 - z^{-1})}{1 - 0.9704z^{-1}}$$

The results of the washout filter addition to the feedback loop on aircraft response was as expected (fig. 12(b)). The highest loop gains used in flight were  $|K_q M_{\delta_e}| = 3.8$  in pitch,  $|K_p L_{\delta_a}| = 3.2$  in roll, and  $|K_r N_{\delta_r}| = 1.2$  in yaw. One further observation is appropriate. The Apollo inertial platform was designed for precise navigation. It had an A/D interface, the coupling data unit, that was not designed to facilitate rate estimation. Even so, the derived body rate provided a signal that could be used satisfactorily for the F-8 DFBW damper modes.

## Command Augmentation System Mode

The pitch CAS mode block diagram is shown in figure 3(c). Derived normal acceleration is blended with derived pitch rate to form the feedback signal,  $C^*$  (ref. 4). A forward loop integrator and bypass path provided zero steady state error and resulted in neutral aircraft speed stability. The  $\cos \theta$  correction term eliminated acceleration feedback in a steady climb or descent. The pilot stick and trim interface with this mode was the same as in the direct and SAS modes.

As was the case in the pitch SAS mode, the performance of the digital CAS mode was essentially as predicted by linear sampled-data systems analysis. However, gain values selected for the  $C^*$  feedback gain during the preliminary design could not be used in flight. The reasons for this are traceable to the noise problems associated with using rates and accelerations derived from the Apollo inertial measurement unit and interface hardware. These problems are not inherent in a digital mechanization. For acceptable noise levels at the horizontal stabilizer, the  $C^*$  feedback gain was too low for optimum response. The flight performance of the CAS mode was reasonable at low speeds, however. Figures 13(a) and 13(b) compare the F-8 DFBW  $C^*$  response in the direct and CAS modes at 180 KIAS and 250 KIAS, respectively. These responses, normalized to the final value, are shown with respect to the  $C^*$  power approach and cruise design envelopes, respectively. The improvement in airplane response is substantial. The 250-KIAS response illustrates the problem encountered in CAS with insufficient loop gain. The short period response was satisfactory, but the aircraft exhibited drift in the 3- to 8-second time period that was actually the first-order mode resulting from the forward loop integrator. This effect was apparent to the pilots.

The CAS mode provided the expected neutral speed stability. Figures 14(a) and 14(b) show the phugoid response of the F-8 DFBW aircraft in the direct and CAS modes, respectively. The aircraft, trimmed at 180 KIAS, was slowed approximately 10 KIAS, where the stick was again centered. The CAS mode held zero pitch rate while the aircraft slowed to a new steady state speed of approximately 138 KIAS. Normal acceleration (not shown) remained constant at nearly 1g during the maneuver, while angle of attack (not shown), which started at  $3.5^\circ$ , stabilized at  $10^\circ$ .

The effectiveness of the CAS mode in suppressing transient effects is shown in figure 15, where the response of the F-8C airplane is compared in the direct and CAS modes during a wing transition (wing incidence changes from  $-1^\circ$  to  $7^\circ$ ). Both responses were without pilot inputs.

Although the performance of the CAS mode was degraded by the limitations of the Apollo hardware, the control system design was relatively straightforward, and flight results again matched predictions quite closely.

## Implications of Digital Fly-By-Wire Design for Active Control Systems

The flight verification of the F-8 DFBW control system design was encouraging from an active control technology standpoint. First, the body of continuous control system design experience is largely applicable. In fact, if there is a

reasonable separation between the half sample frequency and modes of interest, the design can be accomplished in the continuous domain and then exactly transformed to the discrete domain by using the bilinear transform. Furthermore, direct z-plane design is also possible. The most serious difficulty about using the latter approach is lack of experience with direct digital design.

The entire F-8 DFBW three-axis digital flight control system problem could be solved by the Apollo computer in less than a 30-millisecond major cycle time period. The capabilities of a current high performance computer and those of the Apollo computer are:

	Apollo computer	Current computer
Memory cycle time, $\mu$ sec	11.7	1.0
Add time, $\mu$ sec	23.4	2.5
Multiply time, $\mu$ sec	46.8	6.0

The table shows that a state-of-the-art computer can be expected to be an order of magnitude faster than the Apollo computer. This suggests a sample rate or job capacity increase of the same magnitude. Although computer sizing must await a specific ACT configuration, the capability of today's computers would appear to be more than adequate for the control system tasks envisioned.

## PILOTING FACTORS

Considered in conjunction with the control system performance reported in the previous section, the handling qualities results confirmed the feasibility and utility of a digital fly-by-wire control system.

### Handling Qualities Summary

The flying qualities of the F-8 DFBW were evaluated by the pilots in a variety of tasks, including simulated instrument cruise, large or abrupt maneuvers, ground-controlled approaches, gunsight tracking, and close formation flight (paper 7).

Figure 16(a) summarizes the longitudinal handling qualities results for small instrument maneuvers, and figure 16(b) summarizes the results for large maneuvers. The piloting tasks and the comment guide used for these evaluations are given in the appendix. In figure 16(a) the comments and ratings are typical of the findings of pilots at low-to-moderate cruise speeds (less than 350 KIAS). For large maneuvers, the pilot rating improvement with control system sophistication was evident. Pilot acceptance of the SAS and CAS modes was expected on the basis of the control system and vehicle response characteristics reported in the previous section. Some pilots did report a long period overshooting tendency in the CAS mode for certain maneuvers where steady state pitch rates had to be arrested. This correlated with the first-order integrator mode present in the CAS step response.

Figure 17 is characteristic of the improvement in pitch control with digital SAS as seen by the pilots in a wind-up turn. In the direct mode, the F-8C airplane displays its undesirable short period damping. The same maneuver could be performed easily and precisely in the pitch SAS mode.

Ground-controlled approaches were flown down to approximately 60 meters under simulated instrument flight conditions in the various digital modes. Figures 18(a) and 18(b) show typical pilot comments and ratings in the lateral-directional and longitudinal axes. The pilot ratings reflect the improvement in Dutch roll damping provided by the yaw SAS mode. In figure 18(b) pilot A objected to a slight long-term overshooting tendency in the CAS mode.

The tracking performance of the F-8C airplane with the digital control system was degraded by stick quantization problems in both the pitch and roll axes. The parabolic pitch stick shaping resulted in unacceptable quantization steps at large aft stick positions (table 2). This degraded the pitch control of the airplane so much that even augmentation did not significantly improve the tracking performance. Some improvement with roll and yaw SAS was evident in a 2g gunsight tracking maneuver, as the time histories in figure 19 and the associated pilot comments and ratings in figure 20 show. The augmented time histories in figure 19 correspond to a yaw SAS gain,  $K_r$ , of 0.4 deg/deg/sec.

Close formation flight revealed deficiencies in the flying qualities that were often not apparent in maneuvers where the pilot was not required to be "in the loop" as tightly. The improvement shown in figure 21 of the longitudinal flying qualities with digital augmentation is typical. Pilot comments reflected the decreased workload evident in the time history. Barrel rolls, aileron rolls, and wingovers were performed in all control modes. Pilots noted little difference in their ability to perform these maneuvers between the direct and augmented modes, perhaps because these maneuvers tended to be more open loop in nature.

Except in maneuvers where the coarse stick quantization problem was overriding, as in the gunsight tracking maneuver, the DFBW control system markedly improved the flying qualities of the unaugmented F-8C aircraft. Because of the control system performance described in the previous section, this was not unexpected. One pilot who flew F-8C airplanes regularly found the F-8 DFBW vehicle superior even to a standard F-8C airplane with normal augmentation. He noted in particular the lack of the usual mechanical control slop.

The results of the flying qualities evaluations, coupled with the control system performance previously described, indicate that a DFBW control system can perform as well as or better than a conventional control system. The only serious problems encountered were due to the limitations of the Apollo system hardware, which would not be factors in a current design.

## Pilot Interface With the Digital-Fly-by-Wire System

The F-8 DFBW system was designed to permit a simple, yet flexible, interface with the pilot. The normal astronaut interface with the Apollo guidance and navigation system was a display and keyboard device (DSKY) that allowed the operator to display memory contents, load erasable memory, or initiate special programs. The versatility of this interface was important to the design and test engineers during the development and flight test program, but it was not made available to the pilot because of its complexity for a single place aircraft. The pilot's only interface with the digital computer was through a mode and gain panel, which is described in paper 2. The pilot's gain switch mechanization in software contributed to the rapid, safe flight checkout of the digital flight control system. Table 3 lists the different digital control system parameters that were tied to the gain switches during the flight test program. In all, 105 parameters could be connected via software to the three gain switches.

With this gain mechanization, different control system parameters could rapidly be selected and optimized during the research program. More important, the gain switches allowed the designer to make use of the pilot's capabilities. Nominal values of critical gains that were established during the simulation phase were placed on the gain switches along with larger and smaller values. The pilot could change the gain values at any time. For example, one of the gain switches was for pitch gearing. During the first flight, when the effects of the pitch quantization and sensitivity had not yet been established, the pilot took off in the nominal gain position. By 13 minutes after takeoff at 300 KIAS, he had reduced the gearing 10 percent because of pitch control sensitivity. Before landing he evaluated three gain positions, finally selecting the nominal gain value 2 1/2 minutes before touch-down. Apart from its research value, this type of gain selection and evaluation gave the pilot an important degree of freedom. Switch arrangements like this are not unique to digital flight control systems, but the ability to designate such a large number (105) of parameters for this use with virtually no hardware impact is unique to a digital system.

This kind of flexibility can be carried in a digital computer with only a small increase in software complexity. This mechanization approach would also be advantageous in an active control system design, because the F-8 DFBW experience showed that the pilot could rapidly and safely assess open- and closed-loop gain parameter variations about the nominal design point during flight.

Flight experience also showed the multimode digital flight control system to be safe and valuable for both research and proof testing phases of the flight program. The low mode of control in the primary digital system (direct) provided a fallback position for both the pilot and the system. Since the direct and augmented modes were fully synchronized, they could be switched manually or automatically under any dynamic conditions with a minimum and safe aircraft response transient. The pilots took advantage of this multimode mechanization to diagnose the cause of flying qualities deficiencies by comparing airplane response in each mode.

Like the gain switch arrangement, the multimode mechanization makes use of the online monitoring capabilities of the pilot. It too is a good candidate for active

control mechanization, especially for the first few flights. One problem was encountered with this approach. Mode changes could occur without being commanded by the pilot due, for example, to a reasonability test. The mode panel display light configuration would change, but this was not easily detected by the pilot. A master caution and annunciator warning of any uncommanded mode change should have been incorporated.

In summary, software flexibility allowed the test pilot to use his real-time diagnostic capability and to make control system alterations. The alterations could be made with almost no hardware impact and with minimum additional software complexity. These concepts are applicable to early flight testing of full time active control systems.

## MANAGEMENT OF FLIGHT SOFTWARE

The flexibility and versatility of digital flight control system software carries with it the need for software management and control. Perhaps no other area of digital fly-by-wire control raises as many questions and doubts as software reliability. The concern centers on whether it is possible to achieve reliable man-rated flight control software at a reasonable cost and whether software flexibility is compatible with software reliability in a practical application. The F-8 DFBW experience indicates that both questions can be answered yes.

Two aspects of the F-8 DFBW flight test program are of significance to full authority, man-rated digital flight control software. First, not a single software programming error was discovered during the flight test program. Much of the credit for this is due to the thorough verification procedures and facilities developed for the Apollo software, which were also used during the F-8 DFBW program, although on a smaller scale. The procedures are described in detail in paper 5. Secondly, not a single incorrect erasable memory constant propagated to a flight tape that was used to load the Apollo computer. These results are significant because an active control system must achieve the same level of reliability as the basic airframe. The software, in turn, is central to the active control system's reliability, because even though an active control system would have redundant digital channels, the software would be common to all, as it was in the F-8 DFBW system. For this reason, it is worthwhile to examine the software management procedures used in the F-8 DFBW program.

Figure 22(a) outlines the procedures established to control software programming changes during the flight program. These procedures were used three times after the hardwired memory was manufactured and before the first flight. The three special purpose programs written into the erasable memory consisted of pitch and roll parabolic stick shaping, yaw pedal deadband, and a special failure mode monitor.

The software control board in figure 22(a) consisted of representatives from control system engineering, project management, operations, and the pilots' office. Step 7 in figure 22(a) consisted not only of checking out the new code but rerunning former, documented tests on related code to insure proper program

interaction, if any. Extensive files of detailed all-digital simulation runs generated during the initial verification phase were kept for comparison with identical runs with the modified code. This permitted short turnaround time for new additions to the code.

Figure 22(b) shows the steps taken in the alteration of control system constants in the erasable memory. In total, 394 erasable memory locations had to be loaded for each flight. Table 4 gives a breakdown of these constants. Sum checks and built-in data transmission checks in the Apollo computer made it possible to insure that the desired octal numbers were loaded into the computer.

Making sure that the 168 control system values loaded were those actually desired was less straightforward. A punched tape was used to load the computer. During the flight program six tapes were manufactured, each of which represented a different flight control system configuration.

Because the Apollo digital computer is a fixed-point machine, there were magnitude restrictions due to program scaling on most parameters. A variety of other restrictions combined to create a formidable set of rules for the set of control system constants.

An off-line diagnostic digital program (step 3 of fig. 22(b)), which ran on a data processing computer, was developed to ease the burden of verifying the correct content of the master load list, which was kept on standard punch cards. One task performed by the diagnostic program was to check each of the 394 constants against a previously drawn list of reasonable values. This reasonability list was constructed after considerable experience was gained from iron bird simulation, but before the first flight tape was made. The limits were set to encompass the expected or allowable operating range of each variable. Deviations from reasonability limits were flagged by the program as major errors and had to be corrected or signed off by the responsible engineer.

The program also reconstructed digital filter forms from their coefficients and computed their vital characteristics, such as root location, steady state gain, and absolute root magnitude in the z-plane. This was helpful in the case of digital filters, the characteristics of which are not as obvious as those of continuous filters.

One aspect of software control became apparent during the ground testing and simulation of various control system gain configurations. When many gain changes had been made and the precise configuration was in doubt, it was only necessary to dump the contents of erasable memory on magnetic tape to create a complete description of any given configuration. This capability proved to be extremely valuable in the control system refinement stage, and it is unique to a digital mechanization. It was also possible to revert to the baseline configuration merely by reloading memory with the baseline punched tape. This required approximately 3 minutes on the Apollo computer.

In summary, the F-8 DFBW flight experience indicates that highly reliable flight software can be generated and maintained, but that it requires thorough control.



Because the F-8 DFBW program was intended for research, the software program was made more flexible than would be necessary for a production airplane. Even with this flexibility, the software was easily managed with diagnostic digital programs, resulting in high overall system reliability. In fact, changes were made to the digital system more confidently than they were to the airplane's analog systems because there was no hardware impact.

Partly because of the built-in flexibility of the control system mechanization, only minor changes had to be made to the basic program during the flight test program. More program changes would be expected in a prototype system development, thus increasing the need for strict configuration management for software.

The F-8 DFBW flight results confirmed that a DFBW control system could be used in an active control application from the standpoint of software reliability and system flexibility.

## OPERATIONAL FACTORS

### Reasonability Checks

The software reasonability checks used in all augmented modes are surface command rate checks made over one sample period (30 milliseconds). Exceeding the threshold value in any axis resulted in an automatic downmode to the direct mode in that axis. The threshold values per sample period that were found to be usable in flight were  $4.5^\circ$  in pitch,  $13.0^\circ$  in roll, and  $8.0^\circ$  in yaw. These were the smallest values that allowed nearly any pilot input. Ten downmodes occurred in flight. All except four were directly related to sharp pilot step inputs that were made for test purposes. The other four were due to noise peaks that resulted from the angular rate derivation. At least one of these occurred in each axis.

The reasonability check was designed to detect abrupt command changes due to sensor failures or major software faults. Experience with the F-8 DFBW system indicated that the threshold rate limit could be reduced by at least 50 percent in all axes for an operational fighter. If unreasonable commands were allowed to exist for 100 milliseconds (approximately three sample periods), nuisance downmodes would be eliminated without sacrificing protection.

### Digital System Reliability

The F-8 DFBW digital control system utilized a single highly reliable digital computer. This configuration would probably not be used in an active control system. However, the reliability requirements of the F-8 digital system are representative of the requirements of an ACT application. First, no single failure was permitted that would have resulted in the generation of a hazardous control surface command. Second, any serious failure within the digital system had to be detected. In the F-8 DFBW airplane, the failure warning signals were used to transfer control to the analog backup control system. In a redundant digital control system,

operation would continue on the remaining good digital channels after a component failure. F-8 DFBW reliability experience is nevertheless applicable to active control technology in terms of failure detection and also in terms of the features of the digital mechanization that led to a high level of confidence in this system.

No hardware failures occurred in the primary digital flight control system on any flight. This is not surprising in view of the demonstrated in-service reliability of the Apollo guidance and navigation equipment. The discrepancies noted in the DFBW flight system, excluding the actuators and their drive electronics, are listed in table 5. Three component failures occurred in two systems during the 2500 hours of operation (items 4, 5, and 10). Item 4 would have had no impact on normal flight operation. The failure monitor in item 5 was added to the system during the flight program to protect against a potentially hazardous single-point failure mode in the Apollo computer output interface hardware. The monitor box failed before its first use in flight, although it failed in the proper "safe" mode (transfer to the backup control system). The roll stick circuit failure (item 10) would have caused a downmode to the backup control system in flight, as it did on the ground. There were no unresolved anomalies.

### Preflight Procedures

Two preflight test procedures were used for the digital system. The first was a 1-hour test done on the system in the hangar the day before flight. Electrical and hydraulic power were external. The second procedure was part of the total aircraft preflight immediately before flight, with engine-supplied electrical and hydraulic power. The elements of the hangar and flight line preflight tests are listed in table 6. Virtually all the hangar tests except the specialized inertial measurement unit checks and the detailed surface deflection measurements were repeated. Although the digital system's flight line preflight was not optimized in the built-in software, it took only 10 to 15 minutes.

One sensitive preflight test was the computer activity check. A program in the erasable memory was used to measure computer duty cycle indirectly, by detecting idle time over a several second interval. In a given configuration, the duty cycle was consistent within a few percent over several time intervals. This test confirmed proper software operation to a high level of confidence.

During the investigation of the anomalies that occurred on both the iron bird and the F-8 DFBW airplane, it became apparent that it was possible to determine the health of the digital control system rapidly and confidently. The state of the digital control system could be determined in less than 5 minutes by running a self-test and by monitoring the internal control system parameters on the DSKY in the flight control modes. The monitor feature was indispensable during the flight test program. With half a dozen keystrokes, three control system parameters could be displayed in engineering units and in decimal format. The display was updated every second, so even under dynamic conditions the display was intelligible. This monitor format permitted the immediate checkout of virtually any part of the control system. Any future digital flight control system should incorporate such display software capability.

The ability to quickly and confidently assure proper control system performance is of paramount importance to active control systems. The repeatability of the test results of the F-8 DFBW program inspired enormous confidence in the operational readiness of the system before flight. Even personnel not thoroughly familiar with the digital control system were able to perform detailed tests of the system because of the well-designed display and monitor software. The component failures that did occur during ground operation were all detected by the system itself.

## CONCLUDING REMARKS

The F-8 digital fly-by-wire (DFBW) flight program showed the feasibility and advantages of DFBW control for aircraft. Even with hardware designed a decade ago for space applications, an Apollo computer easily handled the F-8 DFBW flight control computation task. This demonstrated the inherent flexibility of a digital system.

The following conclusions can be drawn on the basis of the F-8 DFBW flight test program.

(1) Existing design tools, such as the w-plane frequency response and the z-plane root locus, are suitable for the synthesis of digital flight control.

(2) Flight performance of the digital flight control system verified the accuracy of the sampled-data design results for contemporary command and stability augmentation system modes.

(3) Pilot opinion correlated with that expected on the basis of the control system performance.

(4) A modern digital control system design would display no quantization effects noticeable to the pilot.

(5) The flexibility of the digital control system permits effective use of the pilot in configuration optimization in early flight test stages.

(6) Man-rated software can be safely managed while retaining a high degree of flexibility. The use of off-line diagnostic programs greatly reduced the engineering burden of software management.

(7) Digital system integrity can be rapidly and confidently determined in pre-flight tests by using flexible and extensive engineering interfaces.

The implications of these results for an active control application can be broadly stated as follows:

(1) A DFBW control system possesses the computational ability and flexibility necessary for advanced active control applications. Computer hardware advances are leading control system applications.

(2) Reliable software can be produced and is not an obstacle to an active control application.

(3) The fault detection and preflight test technology necessary for digital control systems exists. Full realization of DFBW potential awaits the successful demonstration of reconfiguration and normal operation after component failures in a practical redundant system.

There was no flight or ground experience that would indicate that a DFBW system could not be used in an active control technology application. In fact, the F-8 DFBW flight program achieved in practice the advantages so long attributed to a DFBW control system and confirmed the suitability of digital control for active control technology.

## APPENDIX

### PILOT COMMENT GUIDE FOR LONGITUDINAL HANDLING QUALITIES

#### Instrument Flight Maneuvering

- (1) Trim the aircraft to desired speed at a zero rate of climb
- (2) Make small heading changes of less than 30°
- (3) Make air traffic control altitude changes
- (4) Make air traffic control speed changes

*Comment on:*

- (1) The ability to fine trim the aircraft
- (2) The need to monitor the pitch axis during lateral-directional tasks
- (3) The ability to make accurate changes in attitude
- (4) Stick breakout and deadband forces
- (5) The acceptability of these aircraft characteristics for fighter aircraft
- (6) Overall longitudinal pilot rating

#### Large or Abrupt Maneuvers

- (1) From trimmed flight, quickly establish a 1.5g to 2.5g turn
- (2) Recover to trimmed, level flight
- (3) Quickly set up a constant speed high performance climb by selecting a target pitch attitude and throttle setting
- (4) Recover to trimmed, level flight at target altitude
- (5) Increase speed 50 KIAS, and retrim

*Comment on:*

- (1) The ability to control attitude and g. Tendencies to overshoot or for pilot-induced oscillations
- (2) The ability to restore the aircraft to trimmed flight
- (3) Stick breakout and deadband forces
- (4) The lag in aircraft response to stick inputs
- (5) Residual small-amplitude oscillations
- (6) The acceptability of these characteristics for fighter aircraft
- (7) Overall pilot rating for the large or abrupt maneuvers

## REFERENCES

1. Deets, D. A.; and Szalai, K. J.: Design and Flight Experience With a Digital Fly-by-Wire Control System Using Apollo Guidance System Hardware on an F-8 Aircraft. AIAA Paper No. 72-881, Aug. 1972.
2. Deets, Dwain A.; and Szalai, Kenneth J.: Design and Flight Experience With a Digital Fly-by-Wire Control System in an F-8 Airplane. Advances in Control Systems, AGARD-CP-137, May 1974, pp. 21-1-21-10.
3. Cooper, George E.; and Harper, Robert P., Jr.: The Use of Pilot Rating in the Evaluation of Aircraft Handling Qualities. NASA TN D-5153, 1969.
4. Tobie, Harold N.; Malcom, Lawrence G.; and Elliott, Elden M.: A New Longitudinal Handling Qualities Criterion. NAECON/66; Proceedings of the IEEE 18th Annual National Aerospace Electronics Conference, May 1966, pp. 93-99.

TABLE 1. --PITCH STICK QUANTIZATION EFFECTS WITH LINEAR GEARING

V, KIAS	Altitude, m	Dynamic pressure, N/m <sup>2</sup>	Stabilizer quantization, deg	Response to quantization		Pilot comments
				n <sub>Z</sub> peak, g	q peak, deg/sec	
300	5,500	13,885	0.53	0.2	1.5	Stepping noticeable, but easy to make small corrections.
365	6,100	19,870	0.5	0.3	2.0	Feel thumping in pitch control. Can see quantization.
400	6,100	22,980	0.3	0.15	1.2	Cannot see quantization.
a <sub>180</sub>	3,050	5,030	0.53	0.05	0.5	Cannot see any quantization. Smooth control.

<sup>a</sup>wing up.

TABLE 2.—QUANTIZATION MAGNITUDE FOR FULL AUTHORITY  
PARABOLIC PITCH STICK SHAPING

Nominal stick position, cm	Quantization size, deg
0	0.1
5	0.3
10	0.7
15	1.2

TABLE 3.—DIGITAL CONTROL SYSTEM PARAMETERS  
TIED TO GAIN SWITCHES

Axis	Mode	Description
Pitch	Direct	Stick gearing
Pitch	SAS	Pitch rate feedback gain
Pitch	SAS	Type of digital filter
Pitch	CAS	Forward loop integrator gain
Pitch	CAS	C* feedback gain
Pitch	CAS	Pitch rate blending gain
Roll	Direct	Stick gearing – wing down
Roll	Direct	Stick gearing – wing up
Roll	SAS	Stick gearing
Roll	SAS	Nonlinear stick shaping
Roll	SAS	Roll rate feedback gain
Yaw	SAS	Yaw rate feedback gain
Yaw	SAS	Interconnect function slope
Yaw	SAS	Interconnect function intercept



TABLE 4.—ERASABLE MEMORY CONSTANTS LOADED  
FOR EACH F-8 DFBW FLIGHT

Description	Number
Control system constants	168
Computer downlink identity tags	100
Inertial subsystem	29
Erasable memory program (parabolic stick shaping)	87
Miscellaneous	<u>10</u>
	Total: 394

TABLE 5. —DIGITAL SYSTEM DISCREPANCIES DURING GROUND OPERATION

(a) Discrepancies.

Item	Discrepancy	Reason for discrepancy
1	Computer restarts	Procedural error
2	Computer time-of-day wrong	Procedural error
3	Inertial measurement unit test result out of specification	Inertial measurement unit degradation for navigation
<sup>a</sup> 4	Yaw direct light cycling on-off	Failed transistor in mode panel
<sup>a</sup> 5	Backup control system down-mode for rudder inputs	Failure in relay in external fail monitor
6	Computer locked in loop	Procedural error
7	Failure of preflight test	Damage to punched tape
8	Aileron offset	Procedural error
9	Roll D/A drift during backup control system self-test	Truncation during repeated primary/backup control system moding
<sup>a</sup> 10	Backup control system down-mode for aileron inputs	Failed resistor in external stick electronics

<sup>a</sup>Primary electronics failures.

(b) Summary.

Component	Failures
Apollo hardware	0
Primary electronics	3

TABLE 6.—ELEMENTS OF F-8 DFBW PREFLIGHT TESTS

Element	Hangar	Flight line
Verify correct memory load	Yes	Yes
Computer self-test	Yes	Yes
Inertial measurement unit fail discretes	Yes	No
Inertial measurement unit turn-on sequence	Yes	Yes
Proper a line	Yes	Yes
Pilot gimbal angle indicator	Yes	Yes
Inertial measurement unit operational test (12 minutes)	Yes	No
Primary/backup control system moding	Yes	Yes
Gain switch discretes	Yes	Yes
Wing position discrete	Yes	Yes
Forced computer restart	Yes	Yes
Inertial measurement unit interface zero and reset	Yes	No
Forced computer fail discrete	Yes	Yes
Mode panel warning lights	Yes	Yes
Differential D/A output – backup control system downmode	Yes	No
Trim rate and trim fail detection	Yes	Yes
Stick-to-surface gearing measurements	Yes	No
Computer activity	Yes	Yes
Check failure monitor box	Yes	Yes
Maximum surface deflections	Yes	Yes
Load time-of-day	No	Yes
Load computer for flight	No	Yes

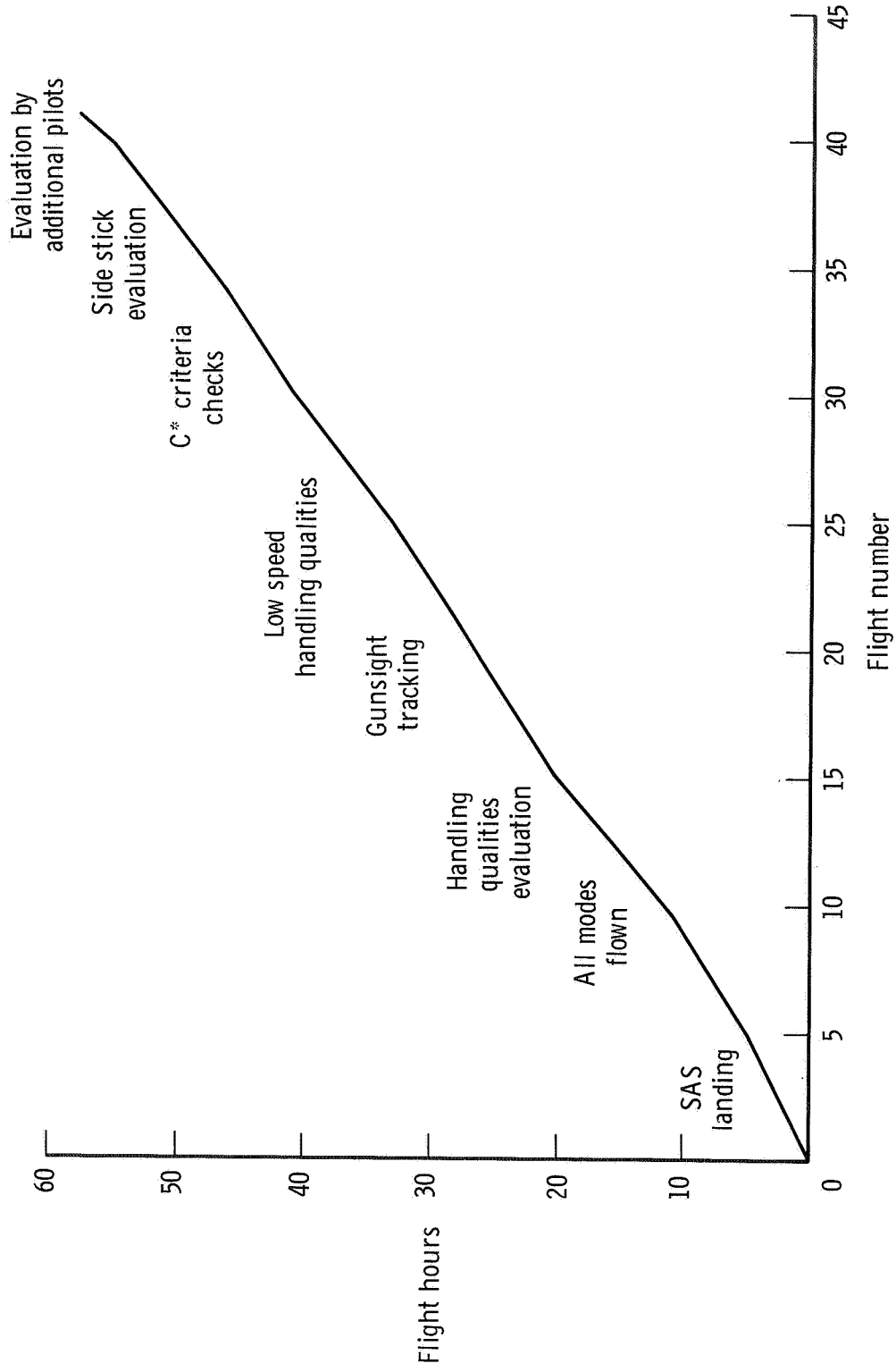

Figure 1. F-8 DFBW flight test summary .

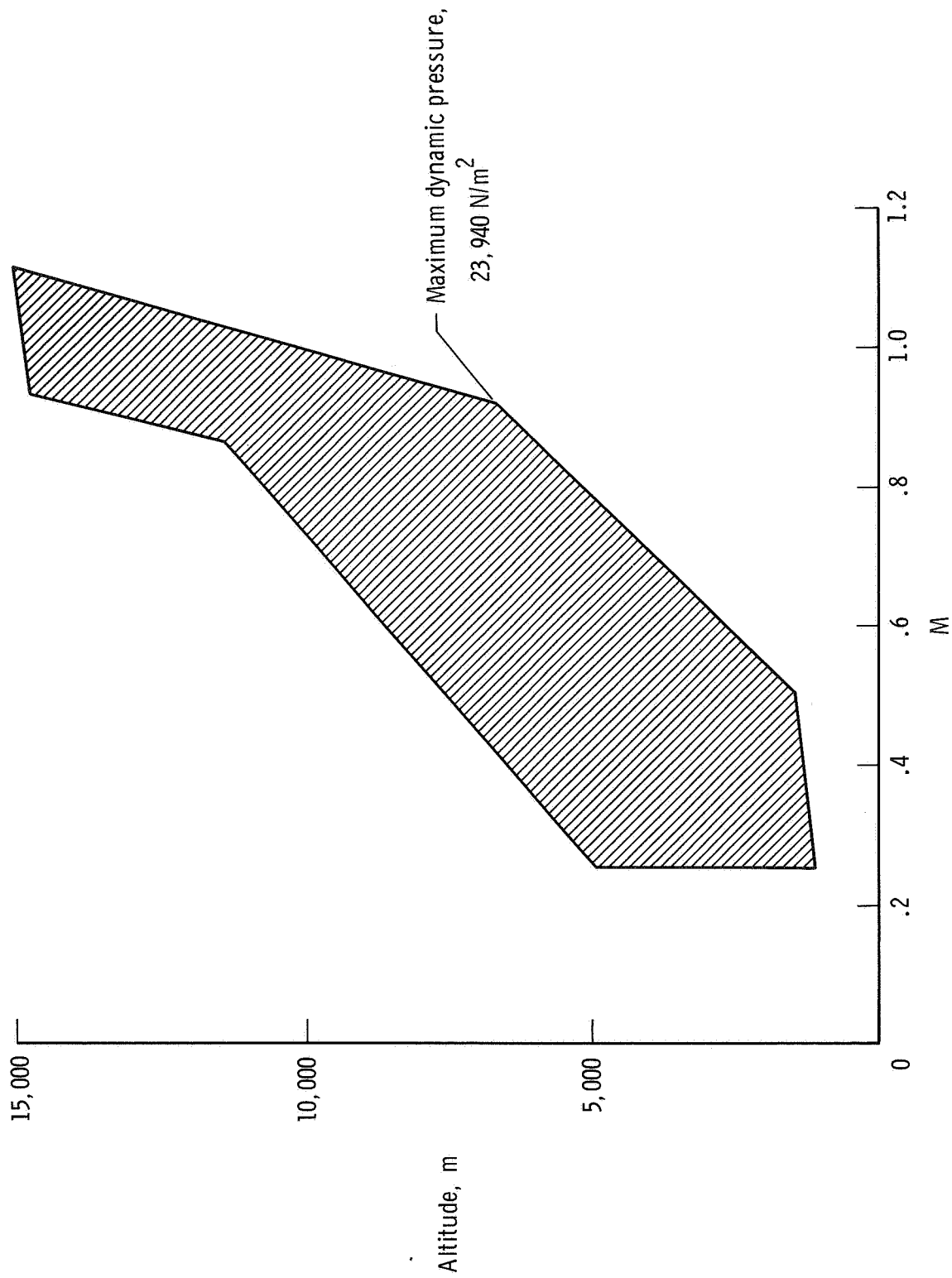
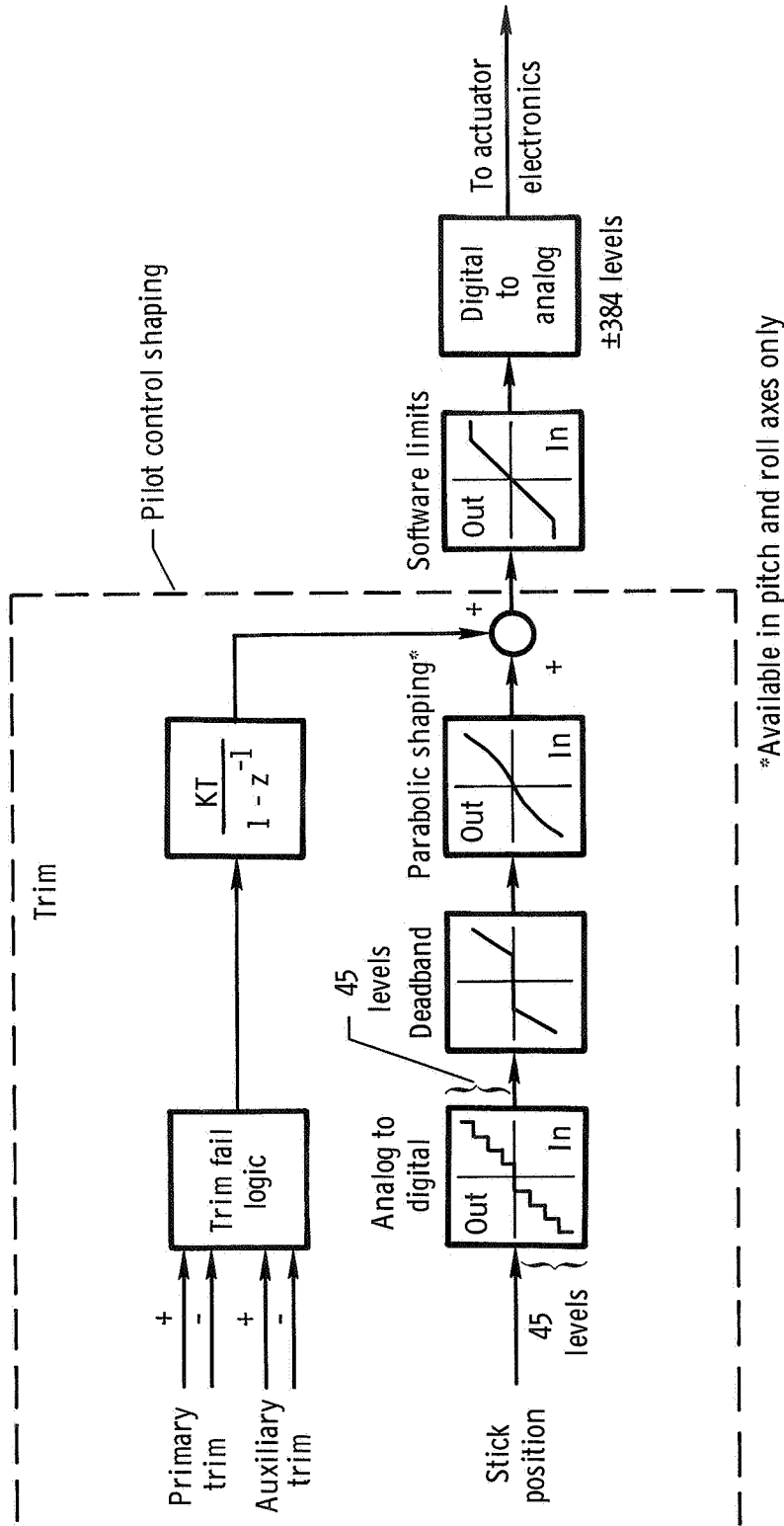

Figure 2. F-8 DFBW flight test envelope.



(a) Direct modes.

Figure 3. Digital flight control law diagram.

Yaw SAS: aileron-to-rudder interconnect

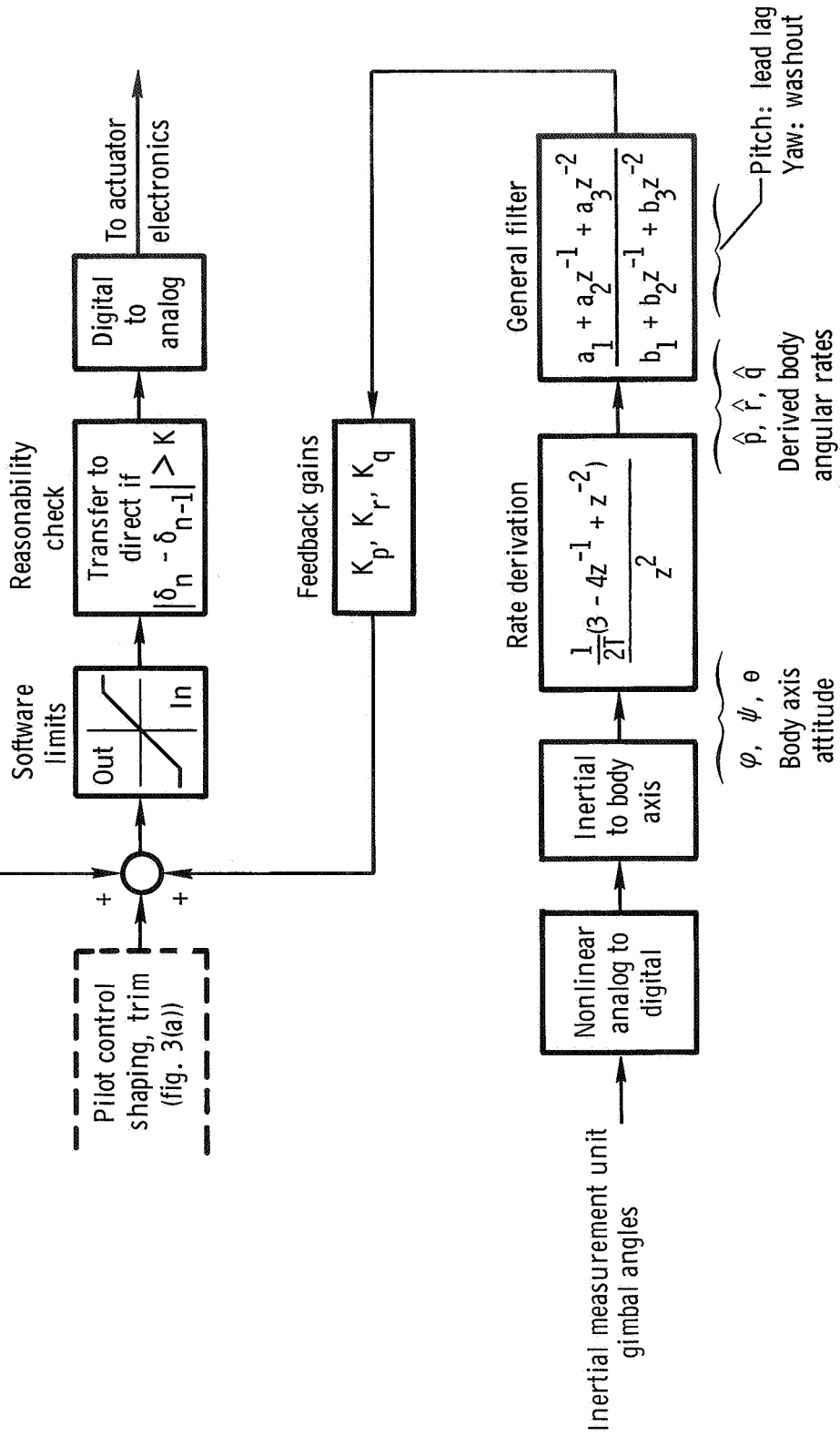

(b) SAS modes.

Figure 3. Continued.

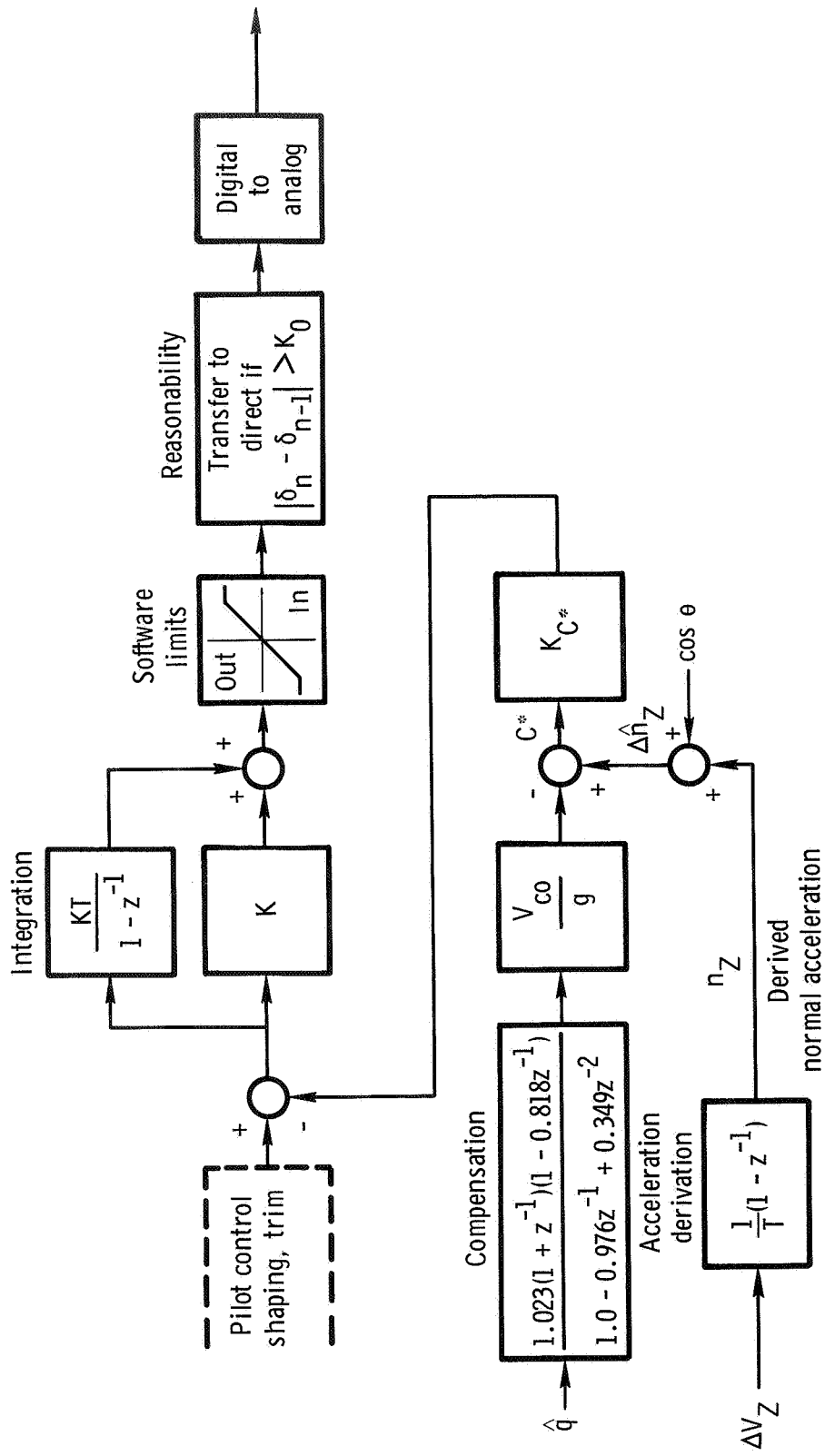

(c) Pitch CAS mode.

Figure 3. Concluded.



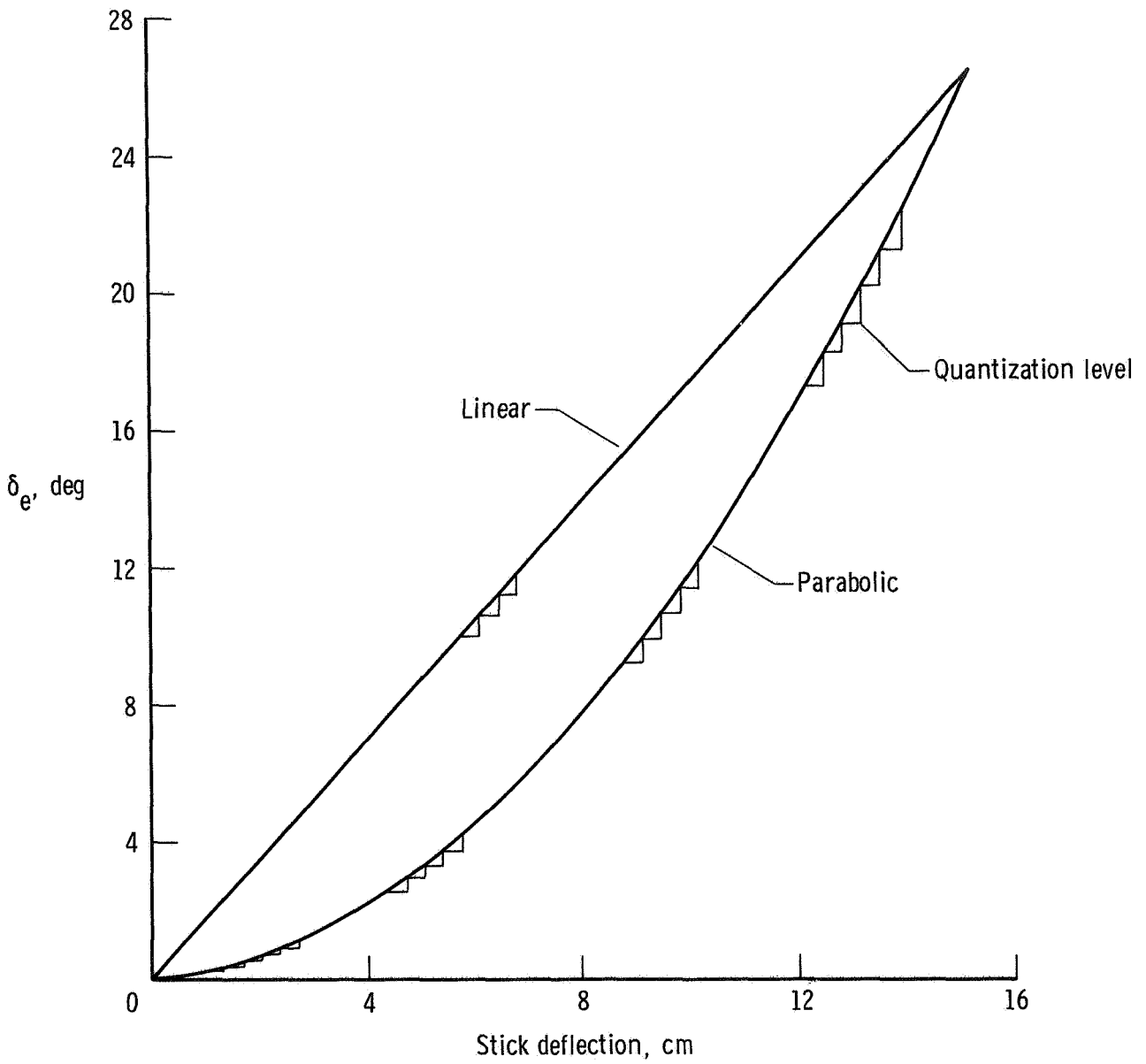

Figure 4. Pitch gearing comparison.

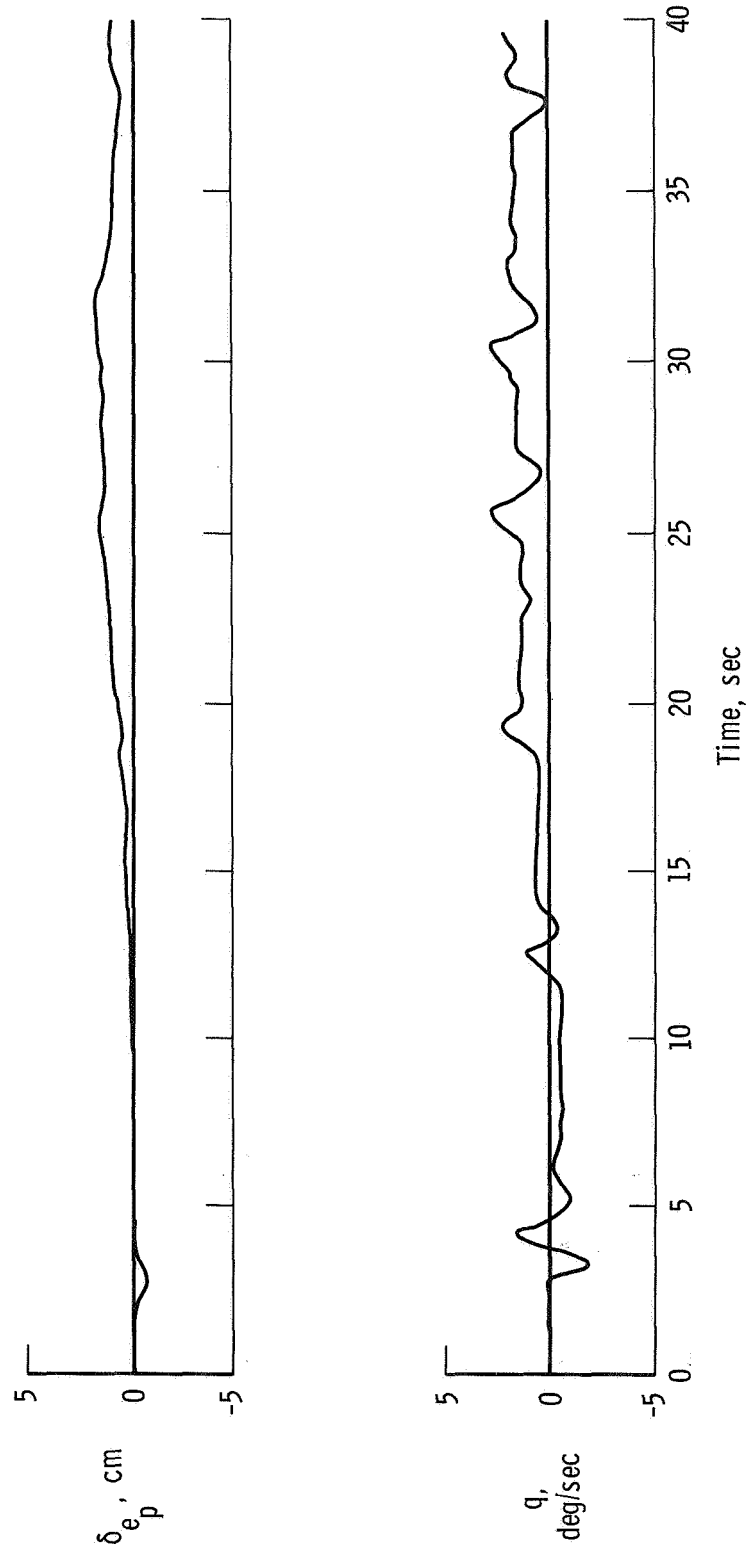

Figure 5. Pitch quantization with linear gearing. 365 KIAS; 6100 m.

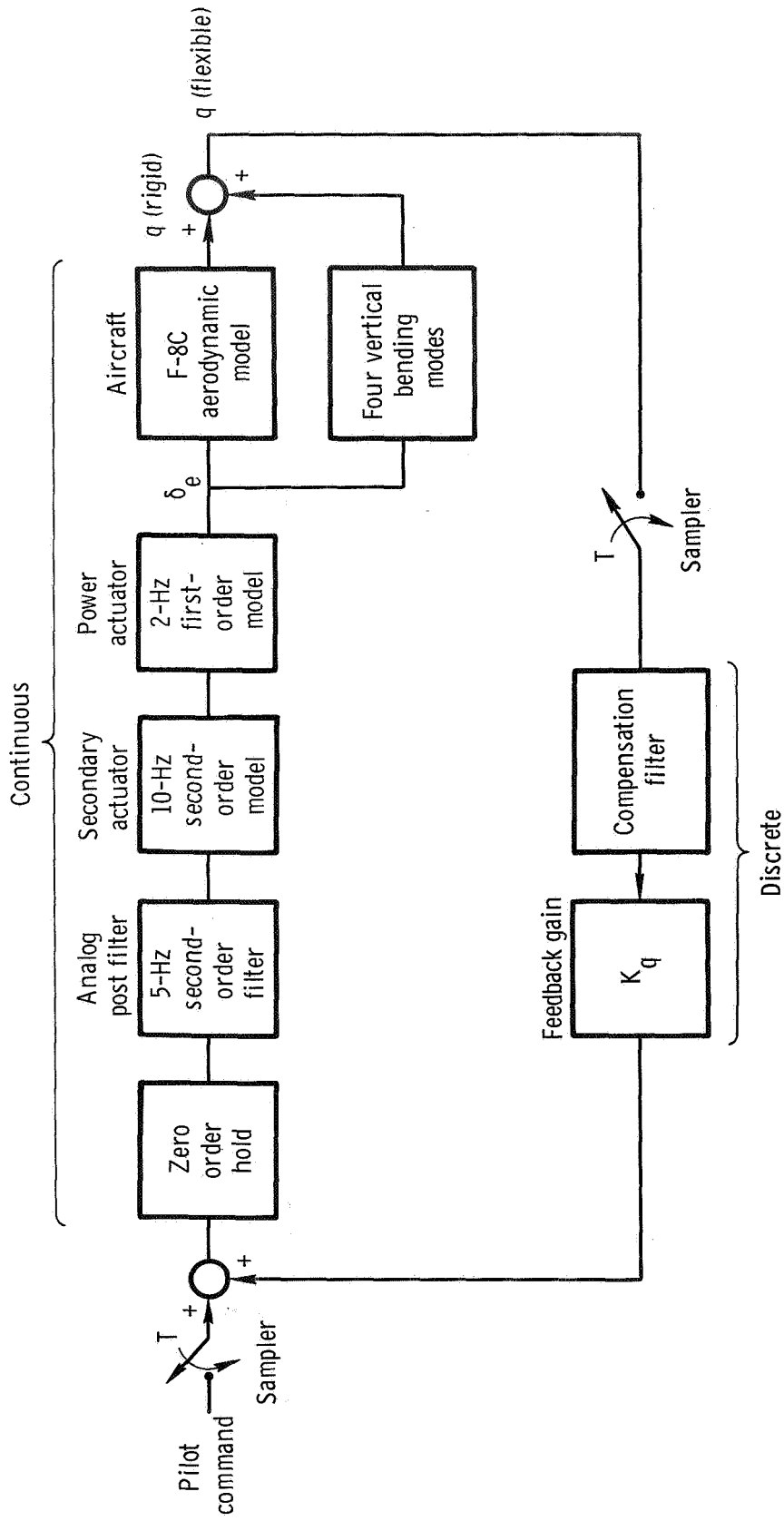
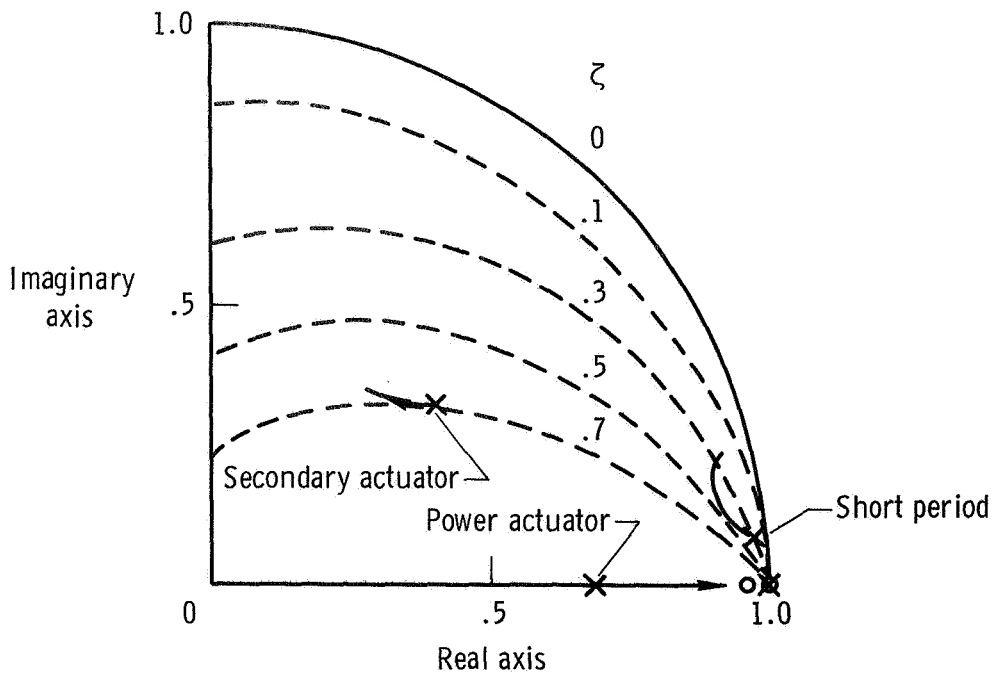
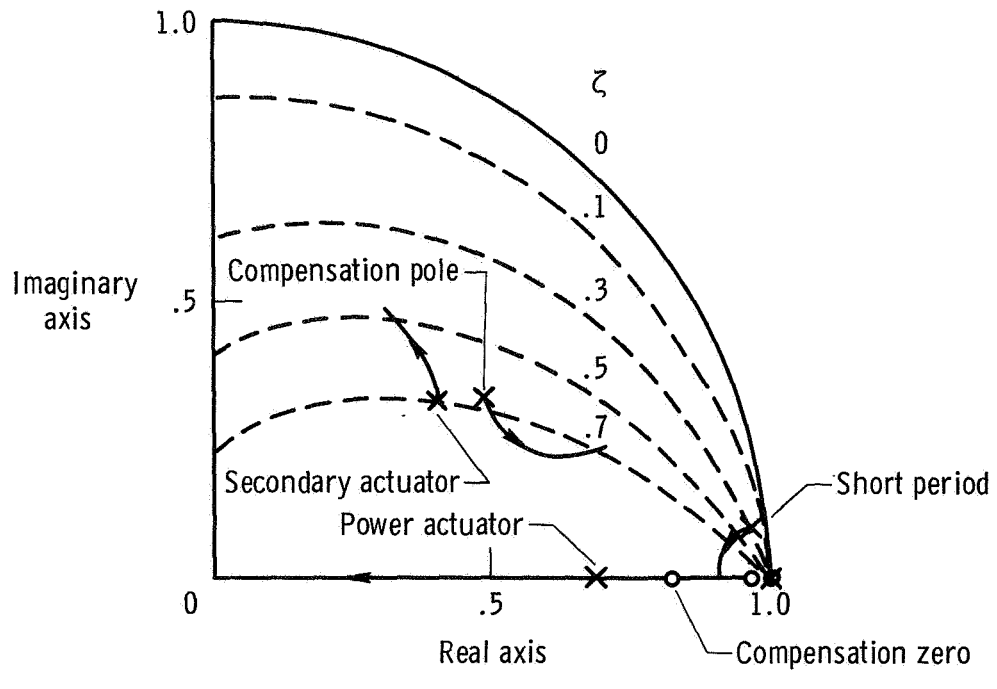

Figure 6. Linear system model for pitch SAS analysis.



(a) Uncompensated system locus.



(b) Locus with lead-lag compensation.

Figure 7. Sampled-data system design.

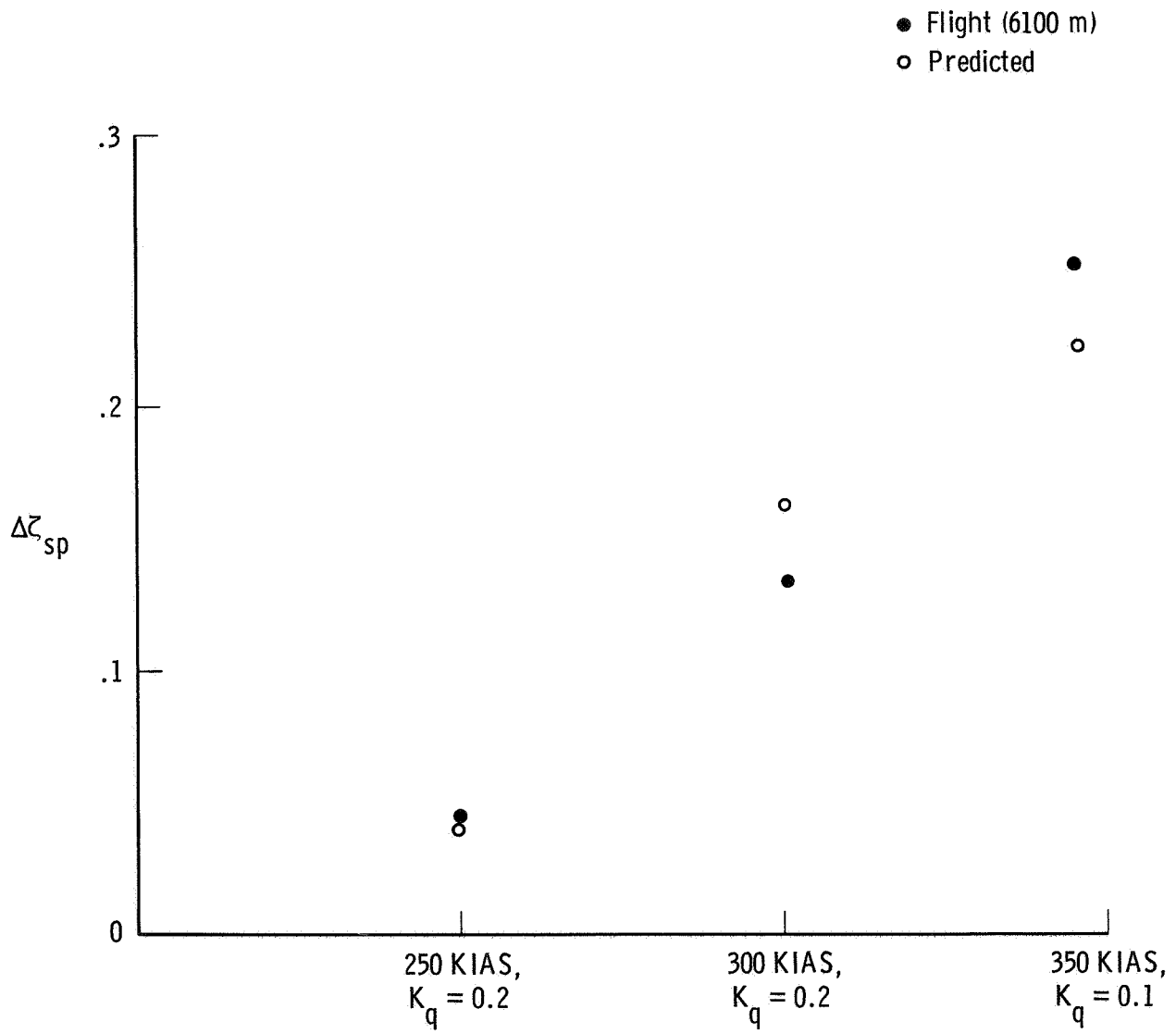

Figure 8. Improvement in short period damping ratio for lead-lag filter.

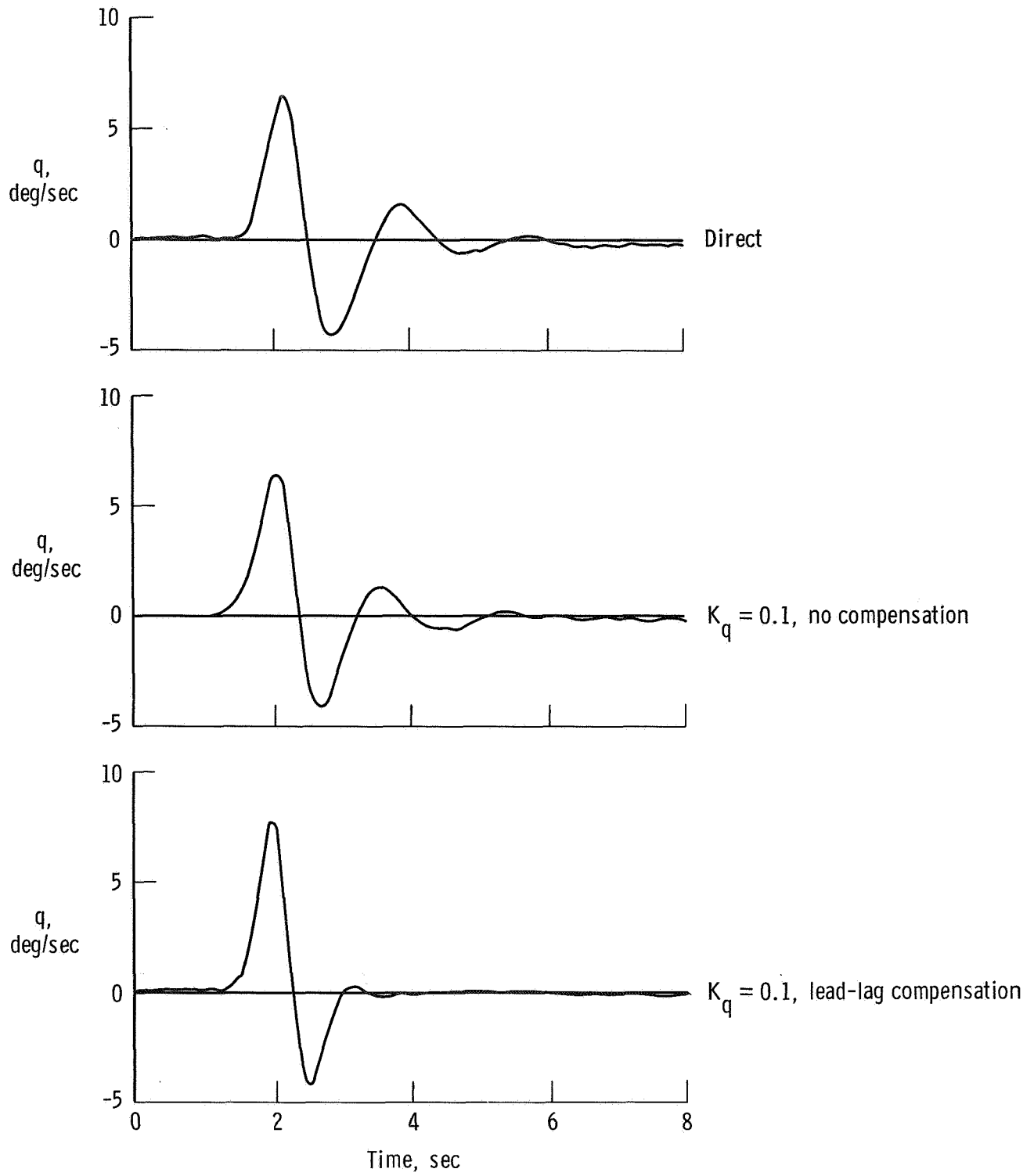
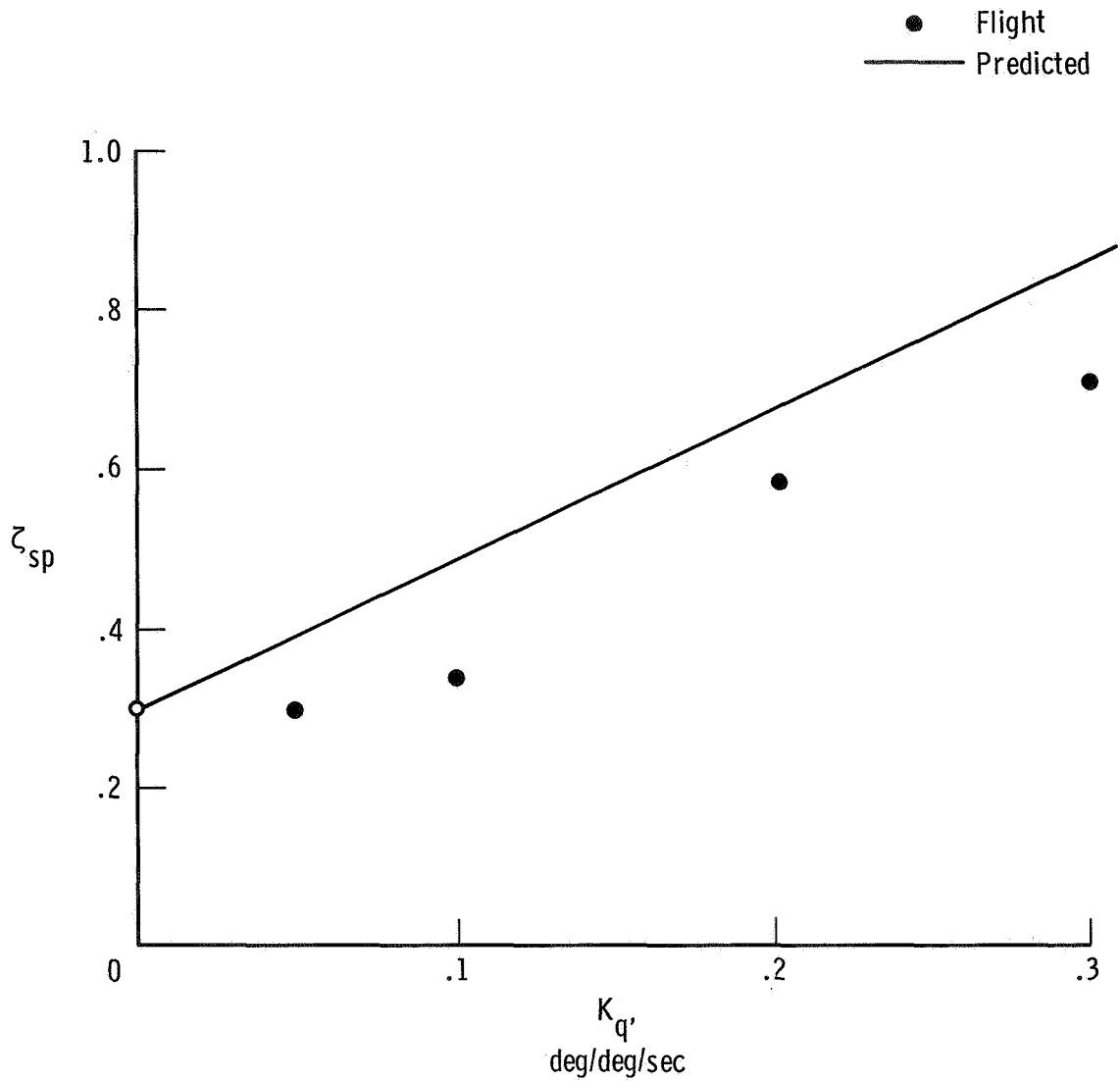
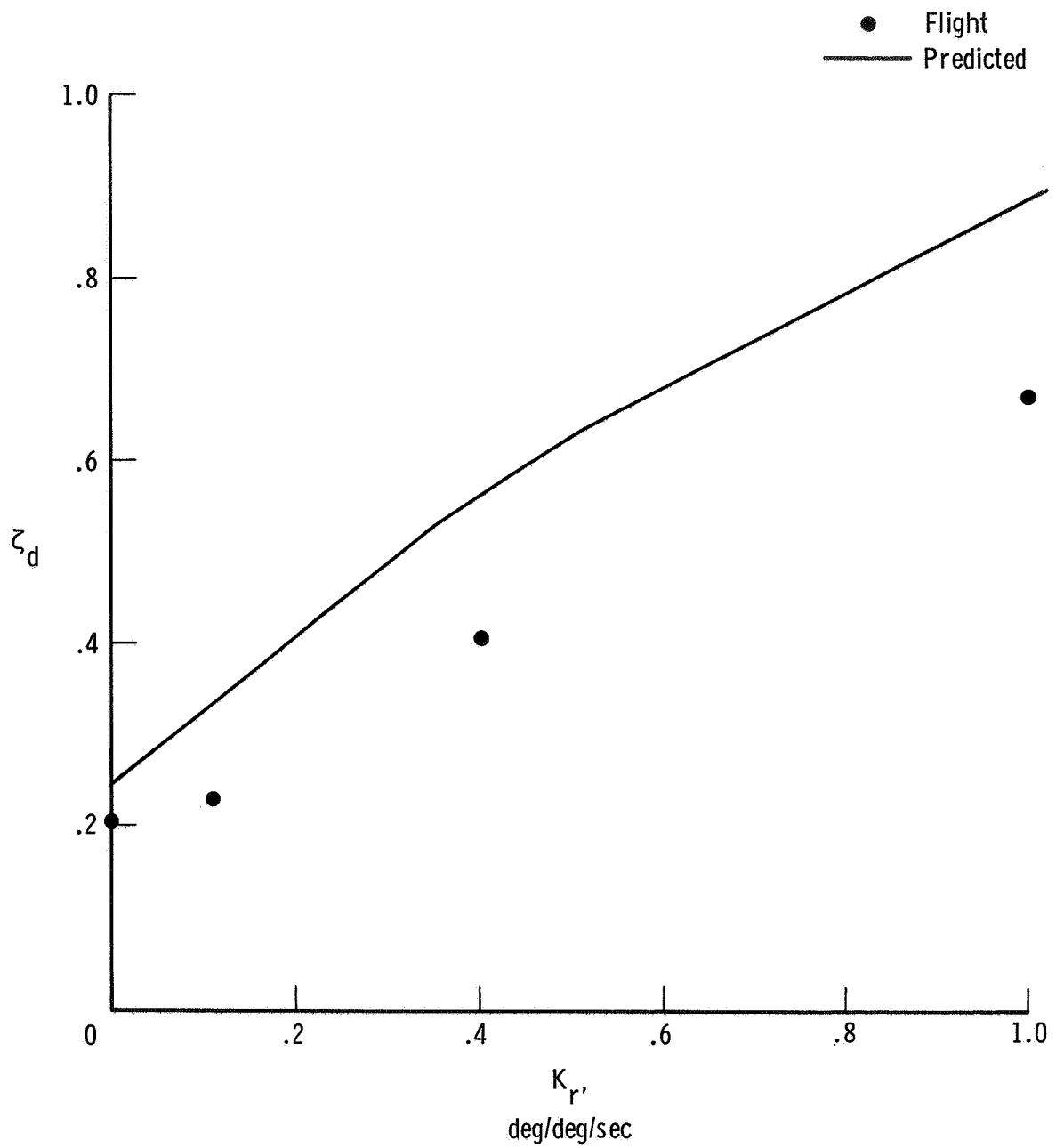

Figure 9. Effect of digital stability augmentation. Pitch SAS; 350 KIAS; 6100 m.



(a) Pitch SAS, 300 KIAS, 6100 m, 10,890 kg.

Figure 10. Comparison of in-flight and predicted digital SAS performance.



(b) Improvement in Dutch-roll damping for increase in yaw rate gain.  
250 KIAS, 6100 m.

Figure 10. Continued.



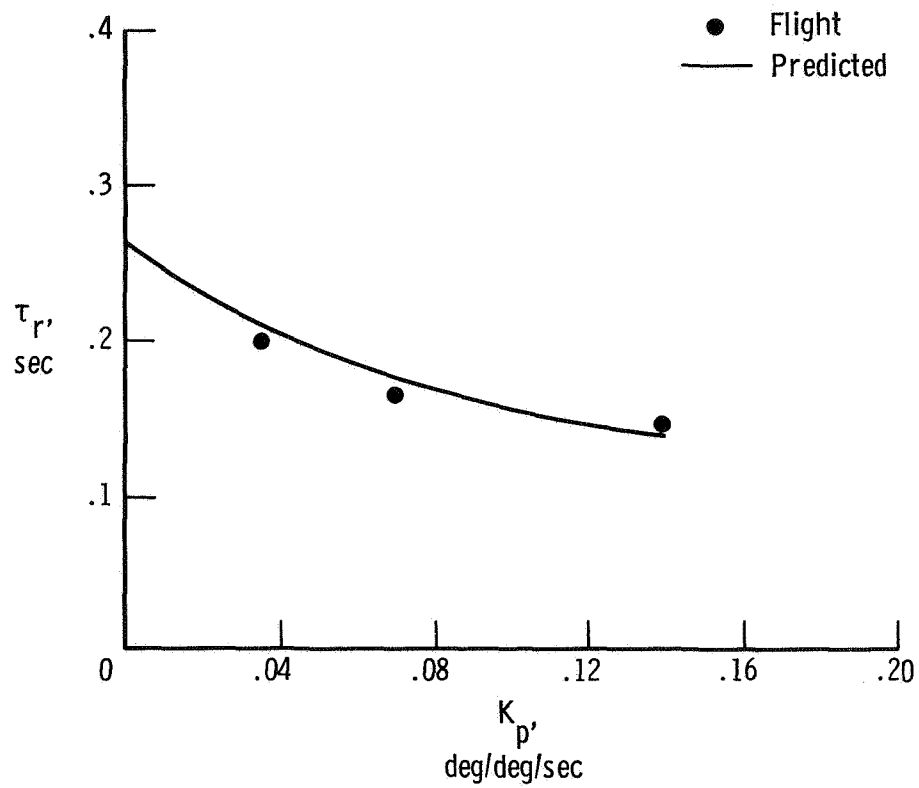

(c) Improvement in roll mode time constant for increase in roll damper gain. 250 KIAS.

Figure 10. Concluded.

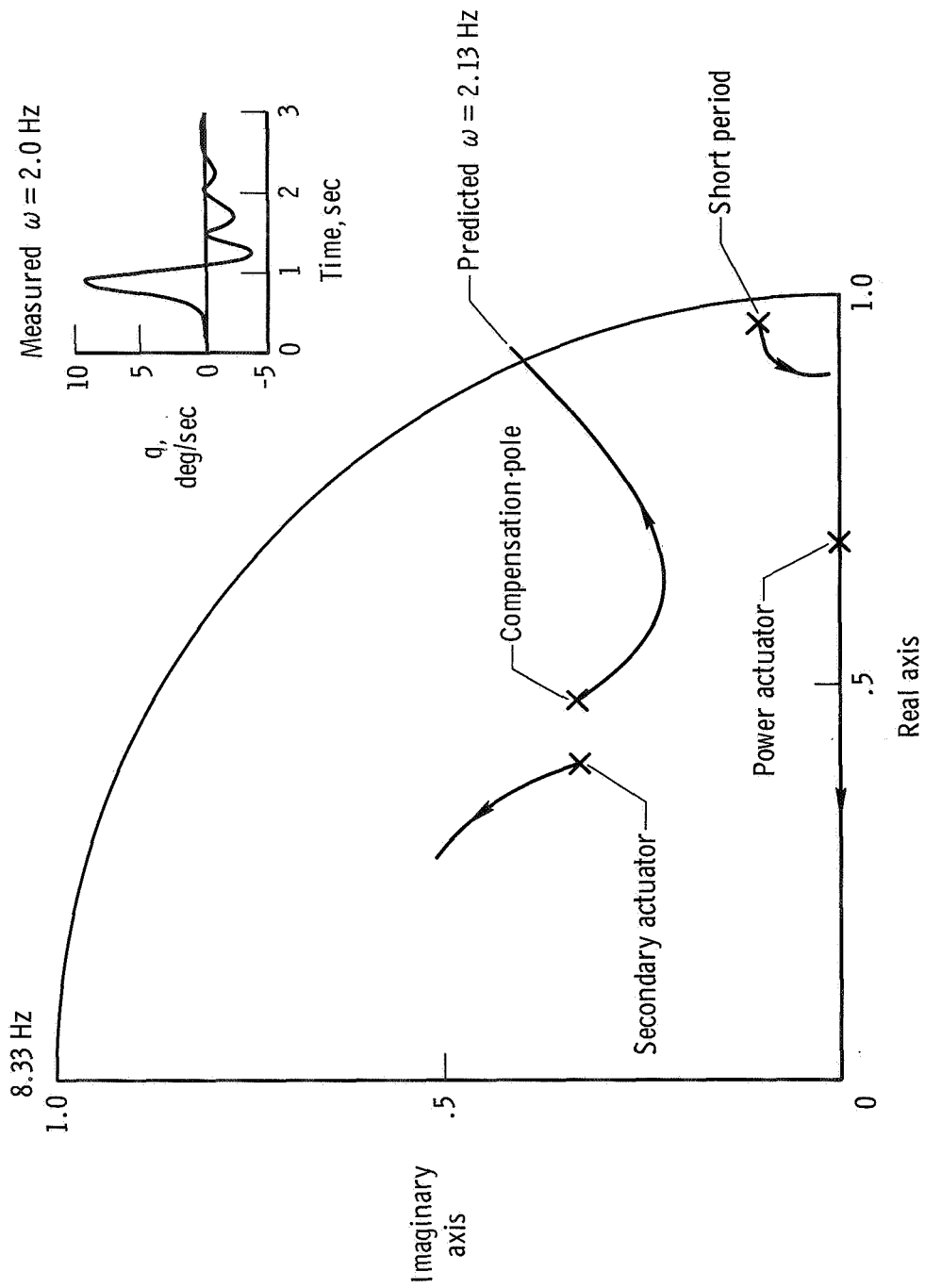
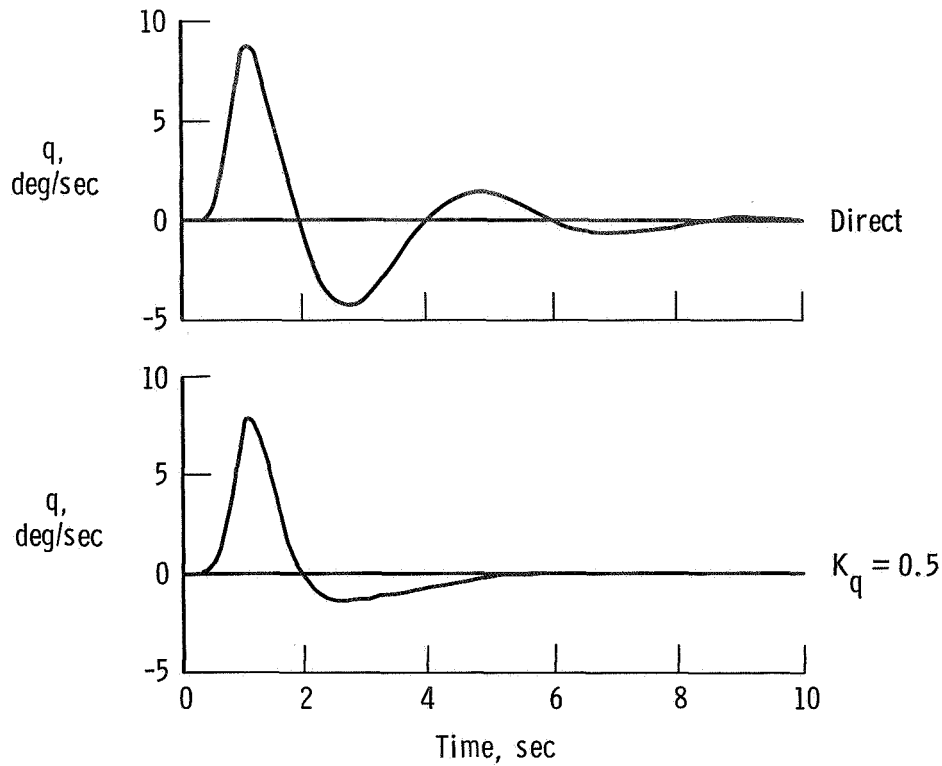
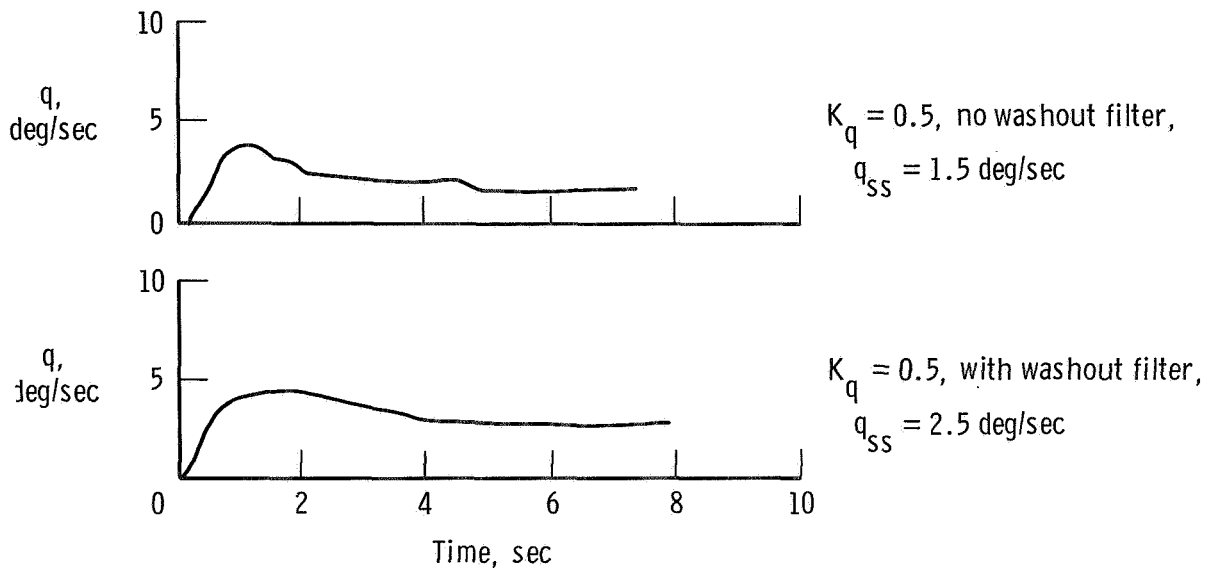

Figure 11. Prediction of system instability at high gain. 350 KIAS; 6100 m.



(a) Effect of SAS on damping ratio. Pulse pilot input.



(b) Effect of washout filter on steady state response. Step pilot input.

Figure 12. Pitch SAS operation at low speed. 180 KIAS; wing up.

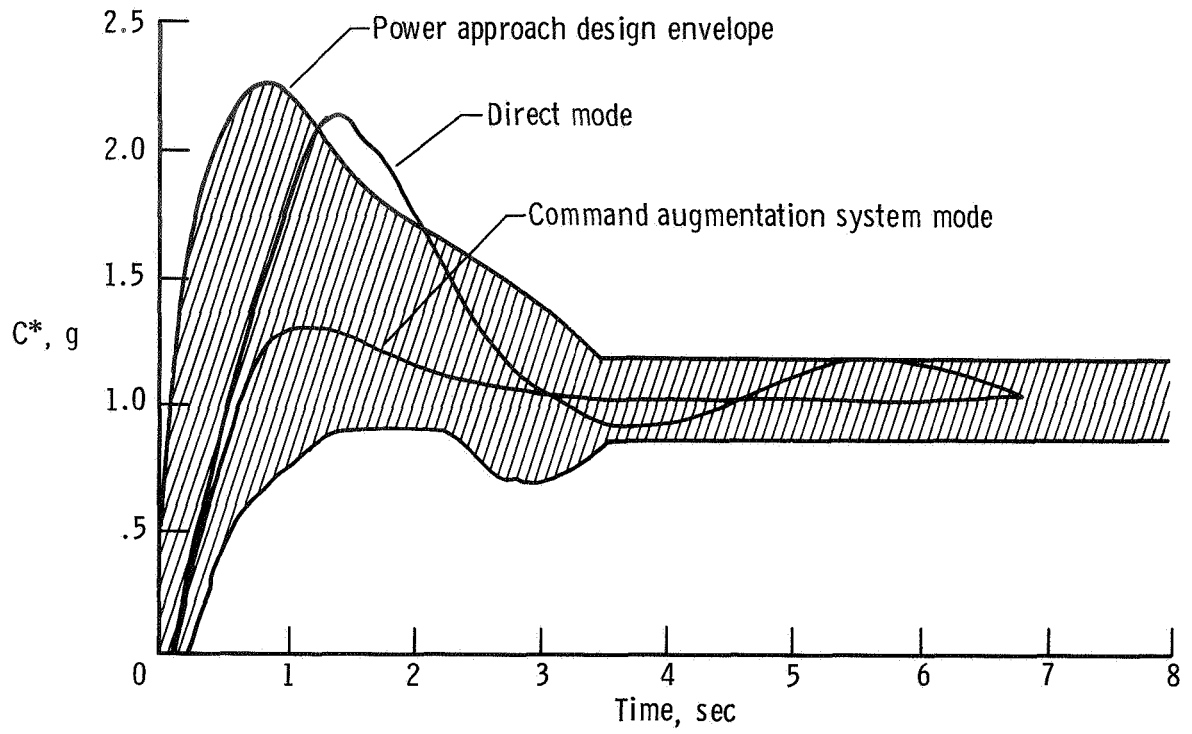

(a) 180 KIAS, 4570 m,  $K_{C^*} = 2.0$  deg/g.

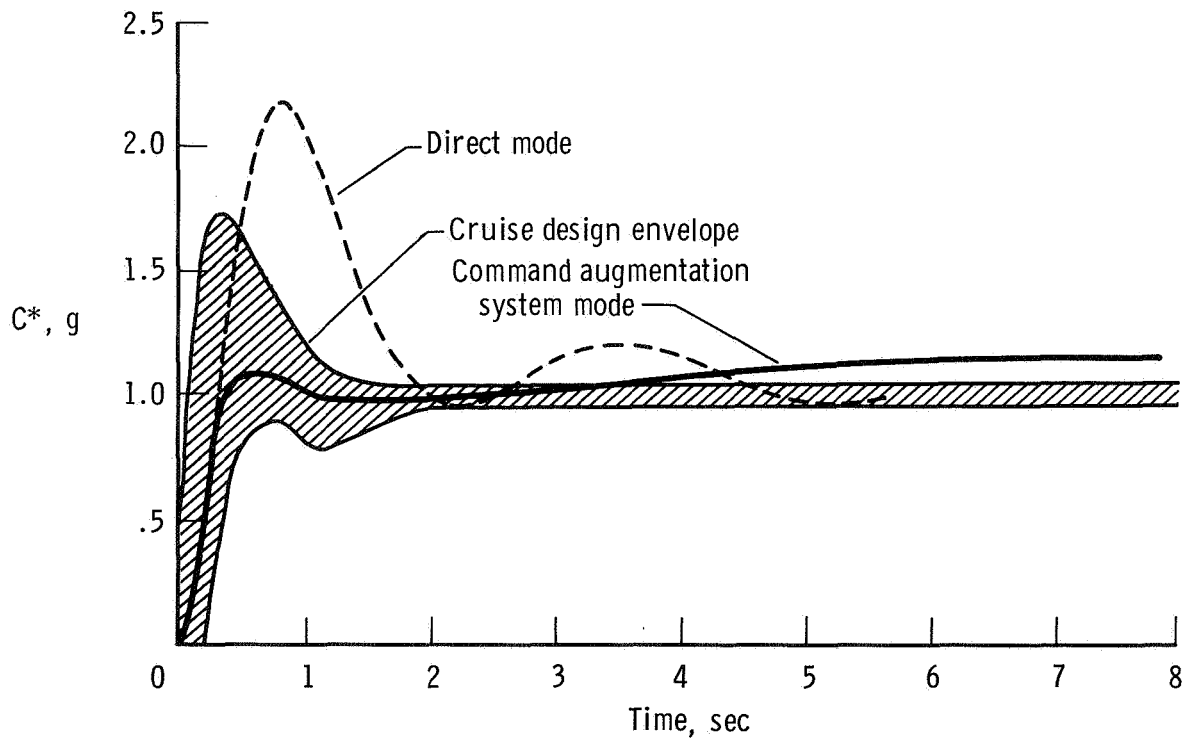

(b) 250 KIAS, 4570 m,  $K_{C^*} = 1.5$  deg/g.

Figure 13.  $C^*$  response of F-8 DFBW aircraft.

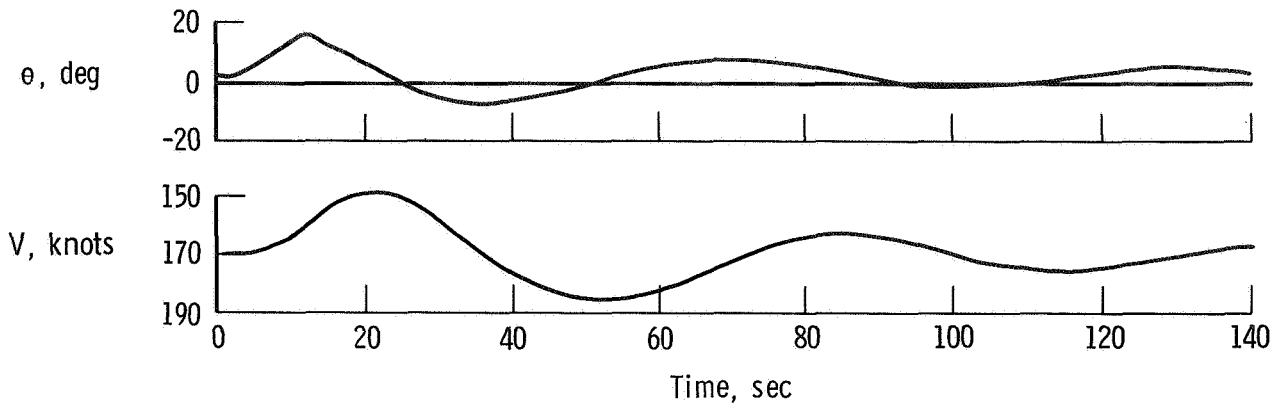

(a) Direct mode, hands off.

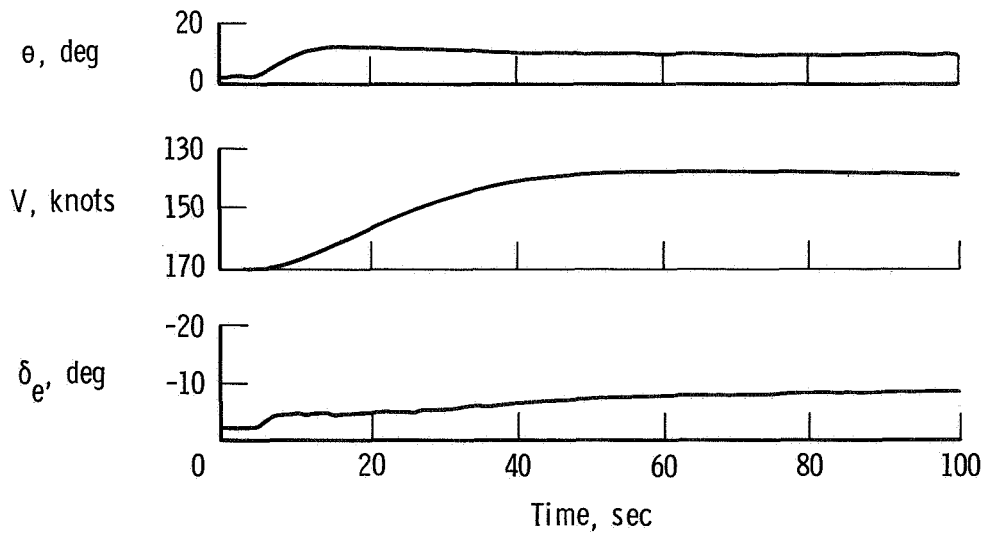

(b) CAS mode, hands off,  $K_{C^*} = 2.0 \text{ deg/g}$ .

Figure 14. F-8 DFBW phugoid response.

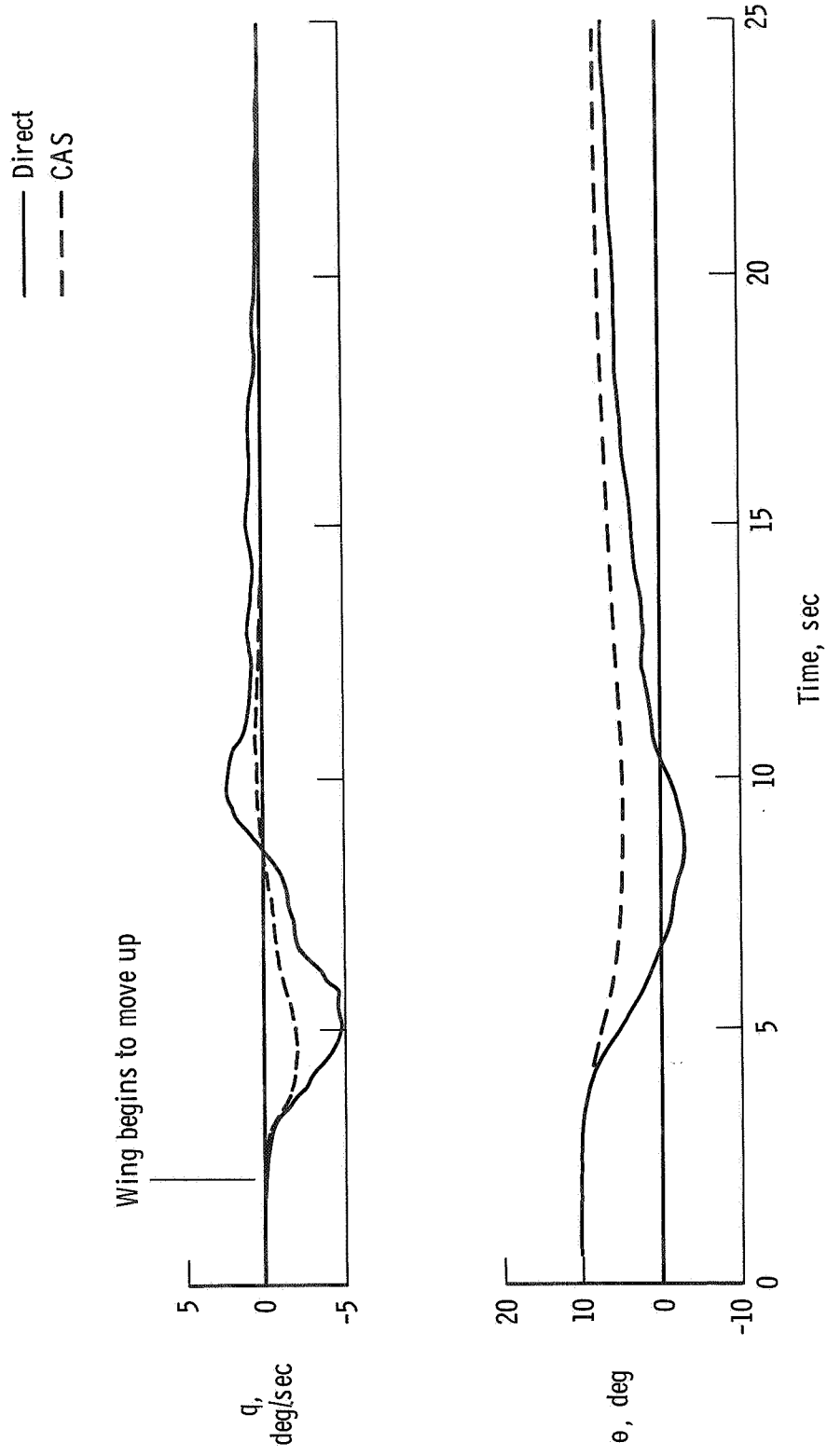
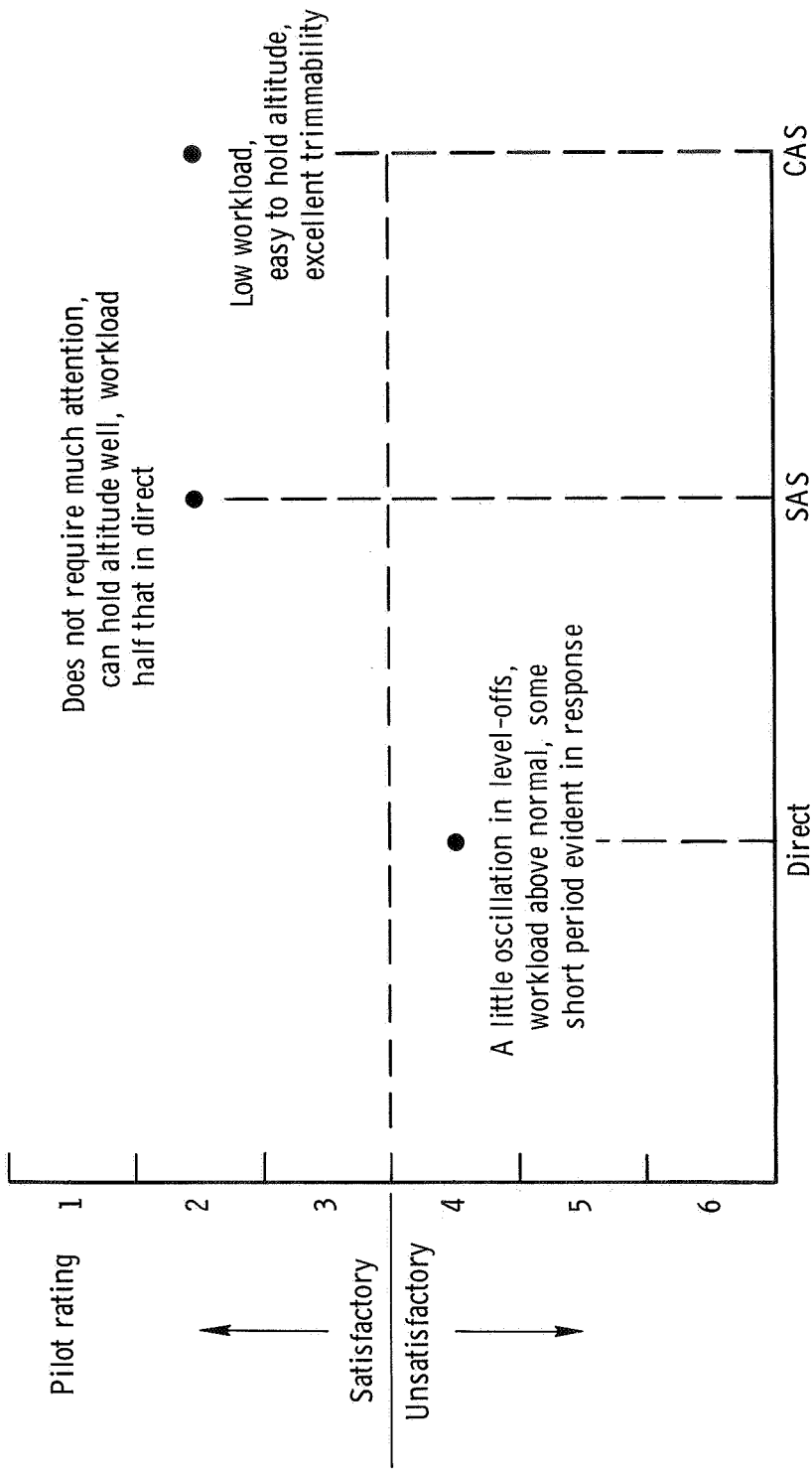
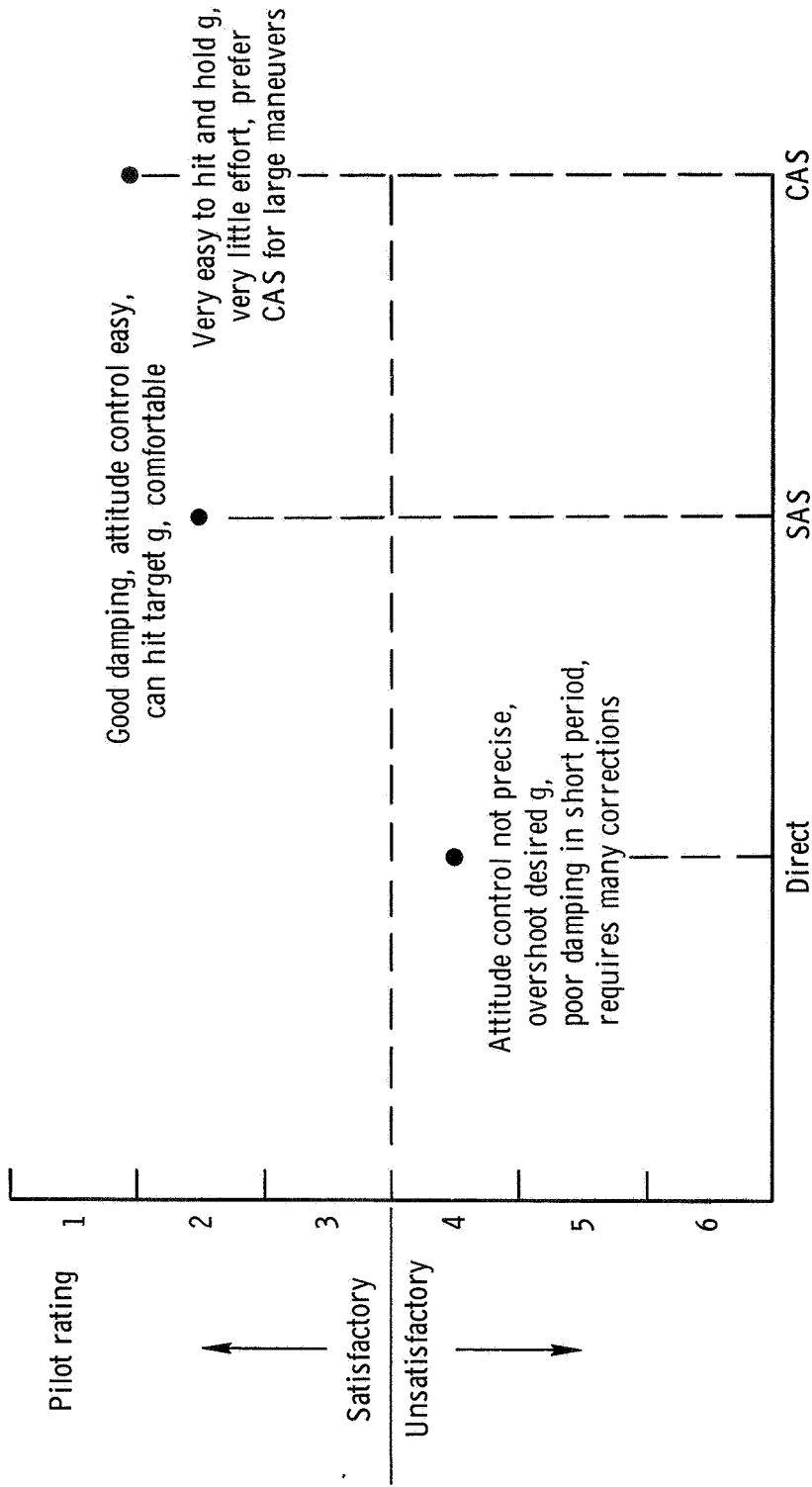

Figure 15. Effectiveness of CAS mode in reducing transient due to down-to-up wing transition.



(a) Instrument maneuvers. 250 KIAS, 4570 m.

Figure 16. Longitudinal handling qualities summary – pitch mode.



(b) Large maneuvers. 250 KIAS, 4570 m.

Figure 16. Concluded.



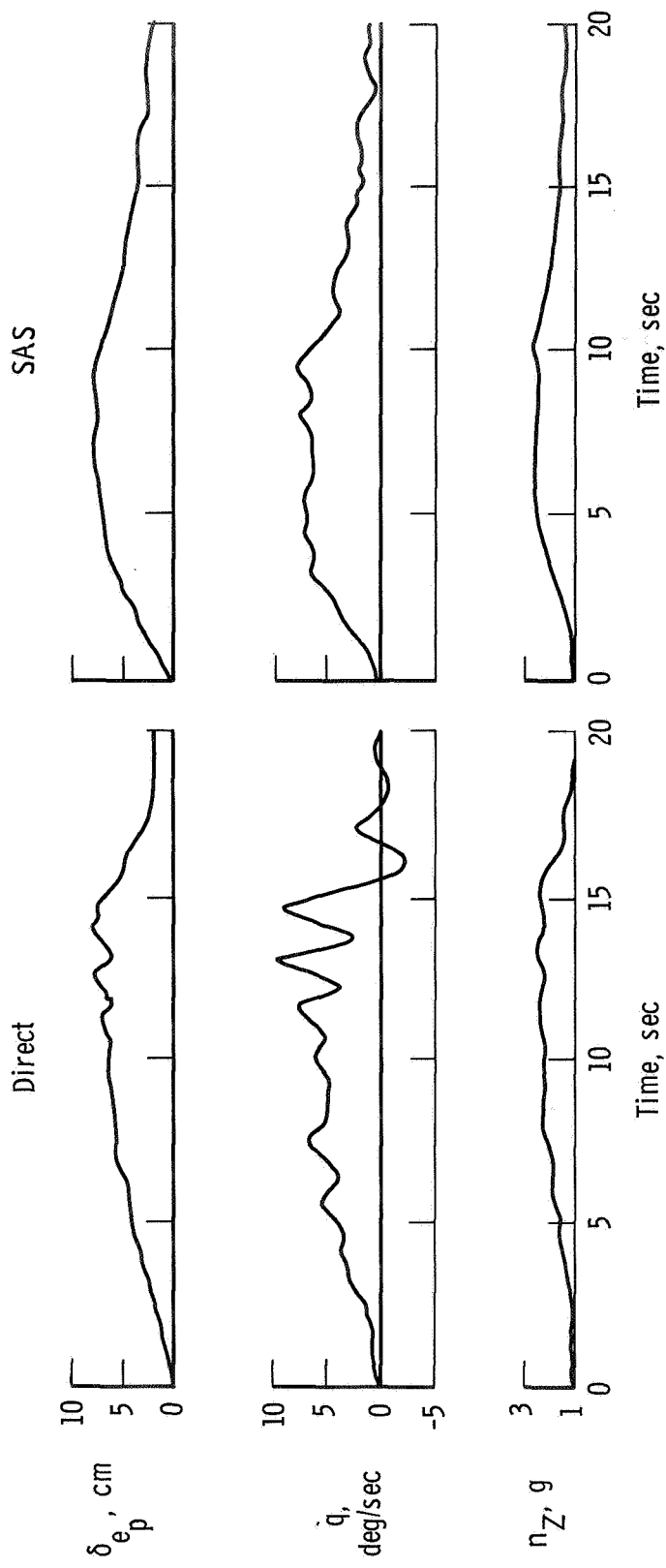
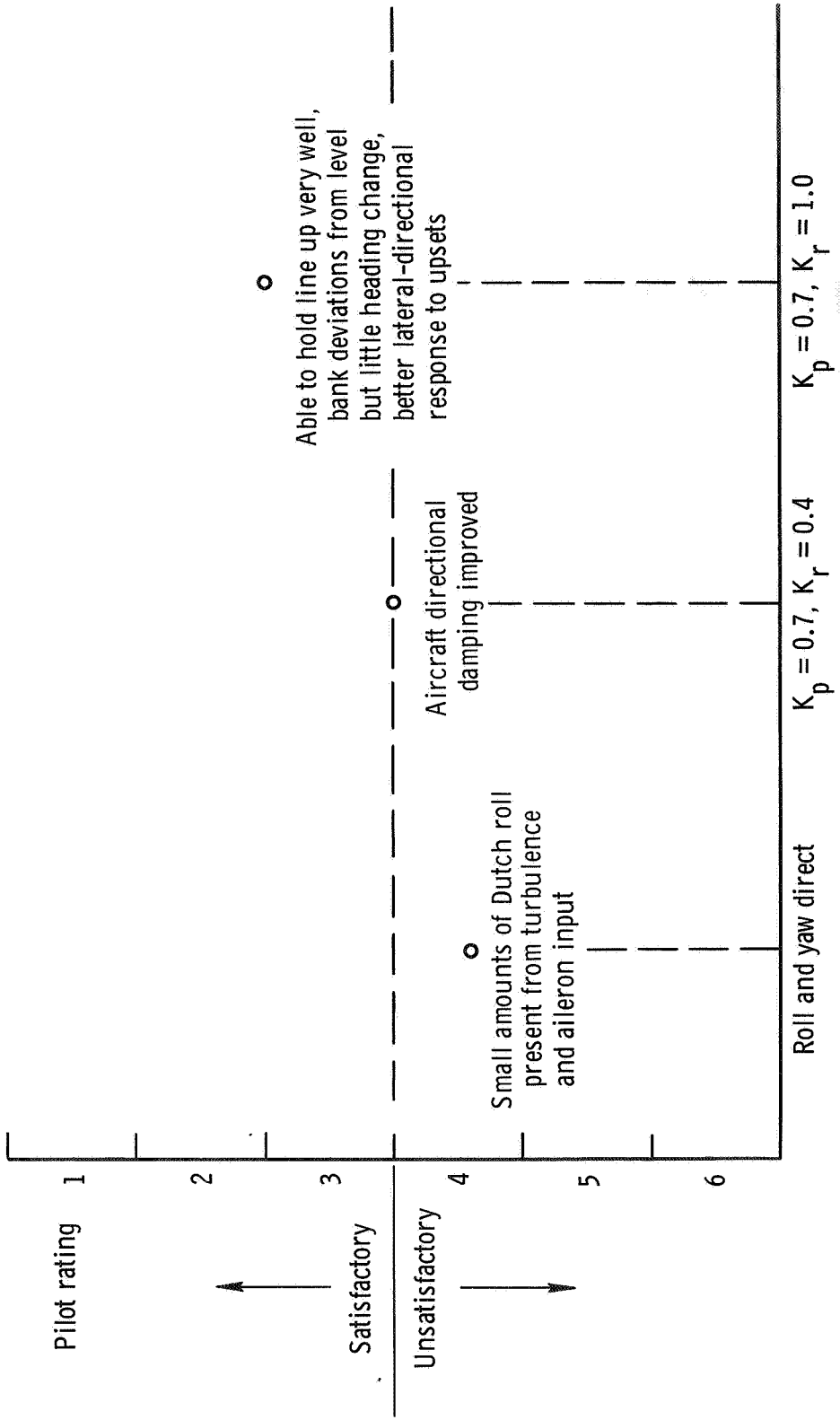
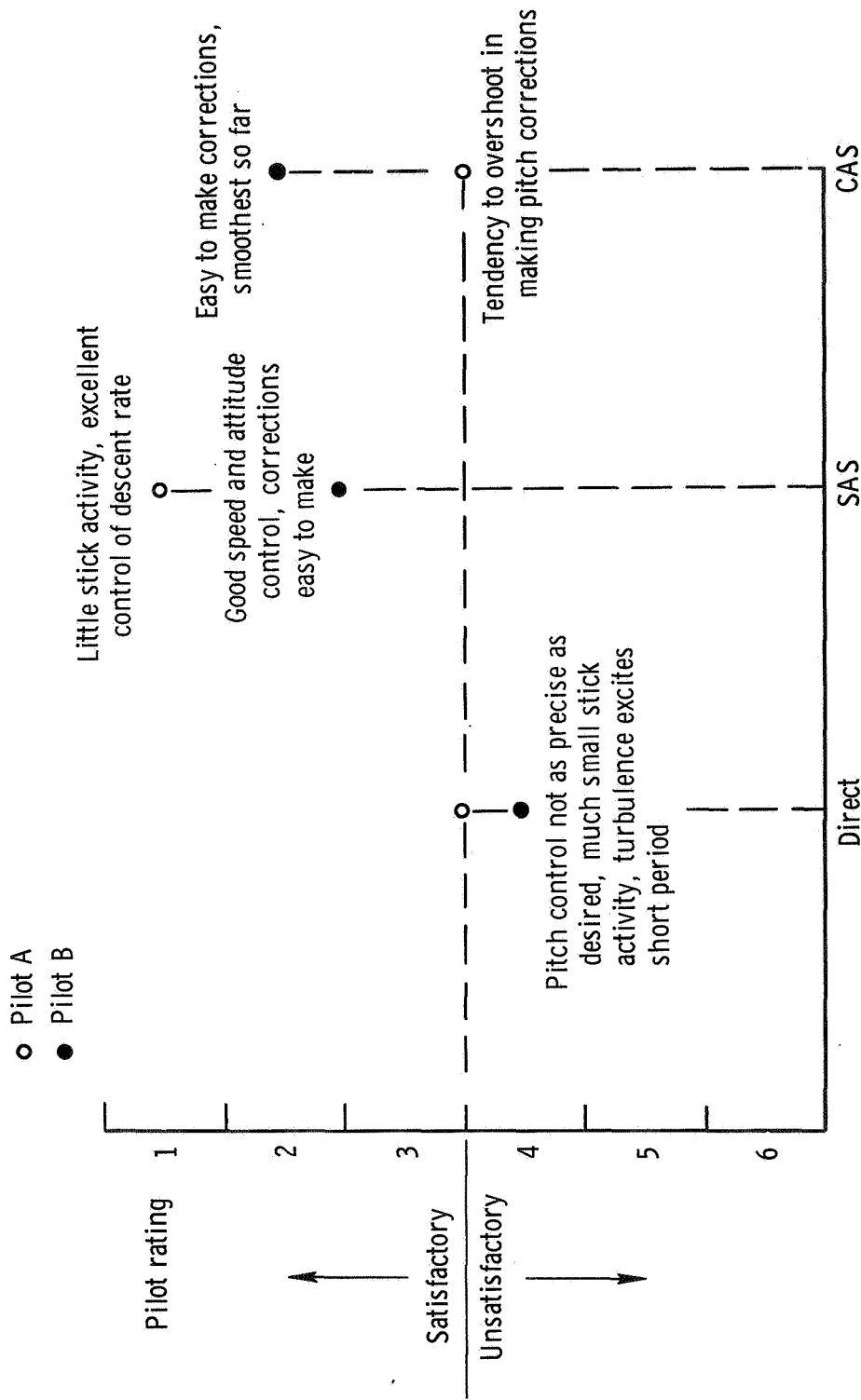

Figure 17. Effect of pitch SAS in wind-up turn. 300 KIAS; 6100 m.



(a) Lateral-directional.

Figure 18. Ground-controlled approach handling qualities summary. Light-to-moderate turbulence.



(b) Longitudinal, pitch mode.

Figure 18. Concluded.

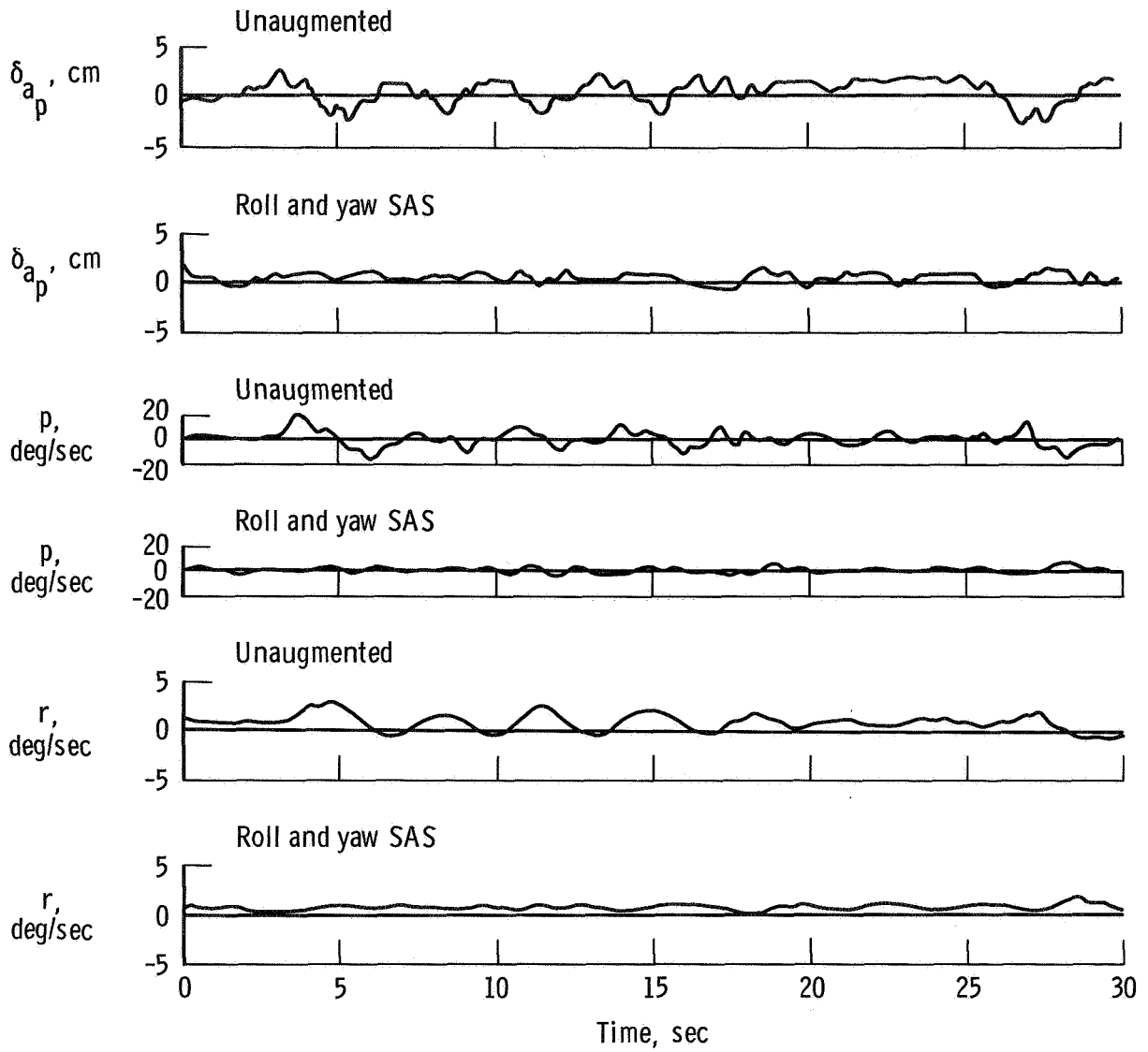

Figure 19. Improvement in lateral-directional flying qualities in gunsight tracking maneuver .

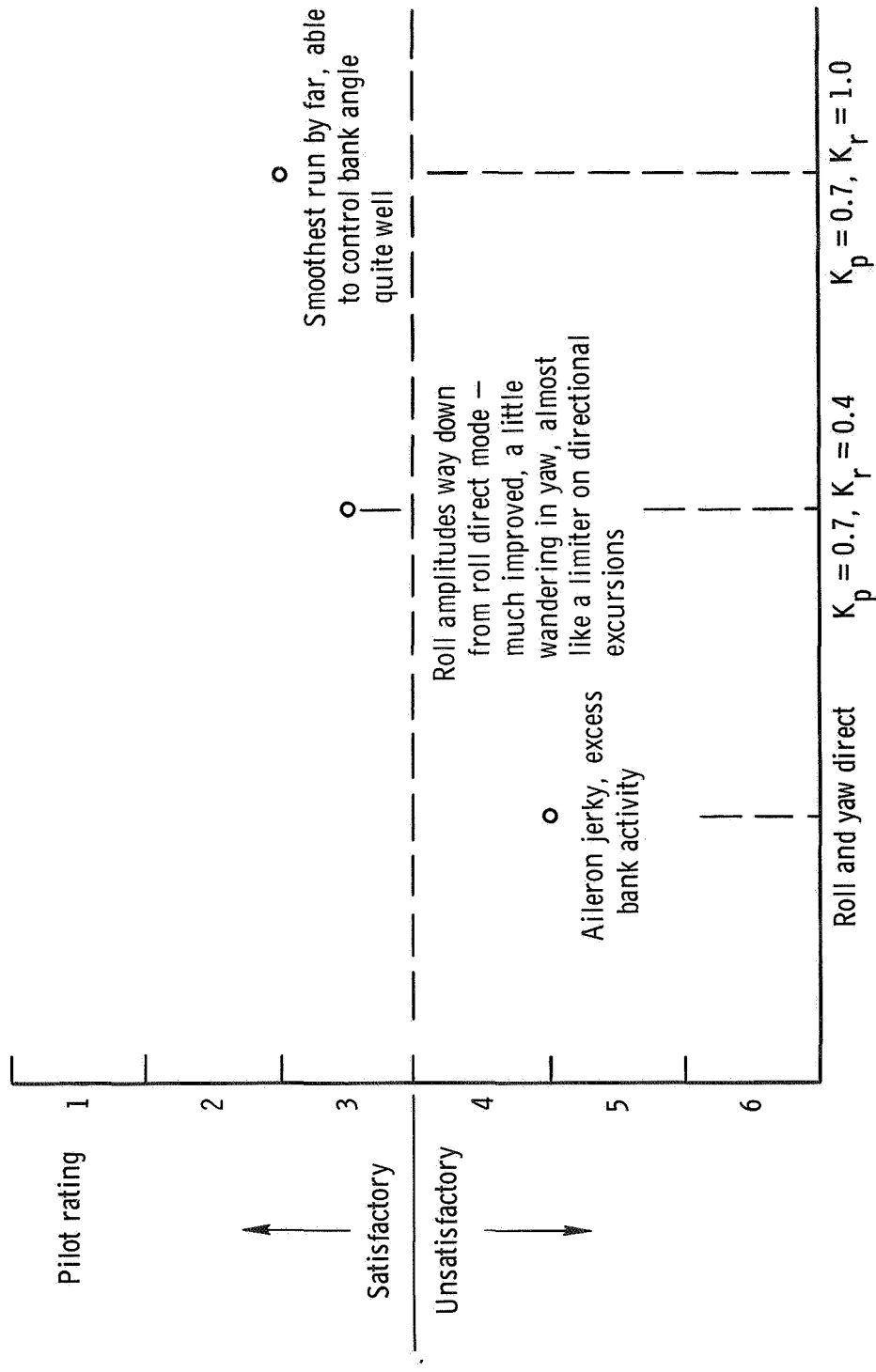

Figure 20. Pilot opinion of lateral-directional flying qualities in gunsight tracking maneuver.

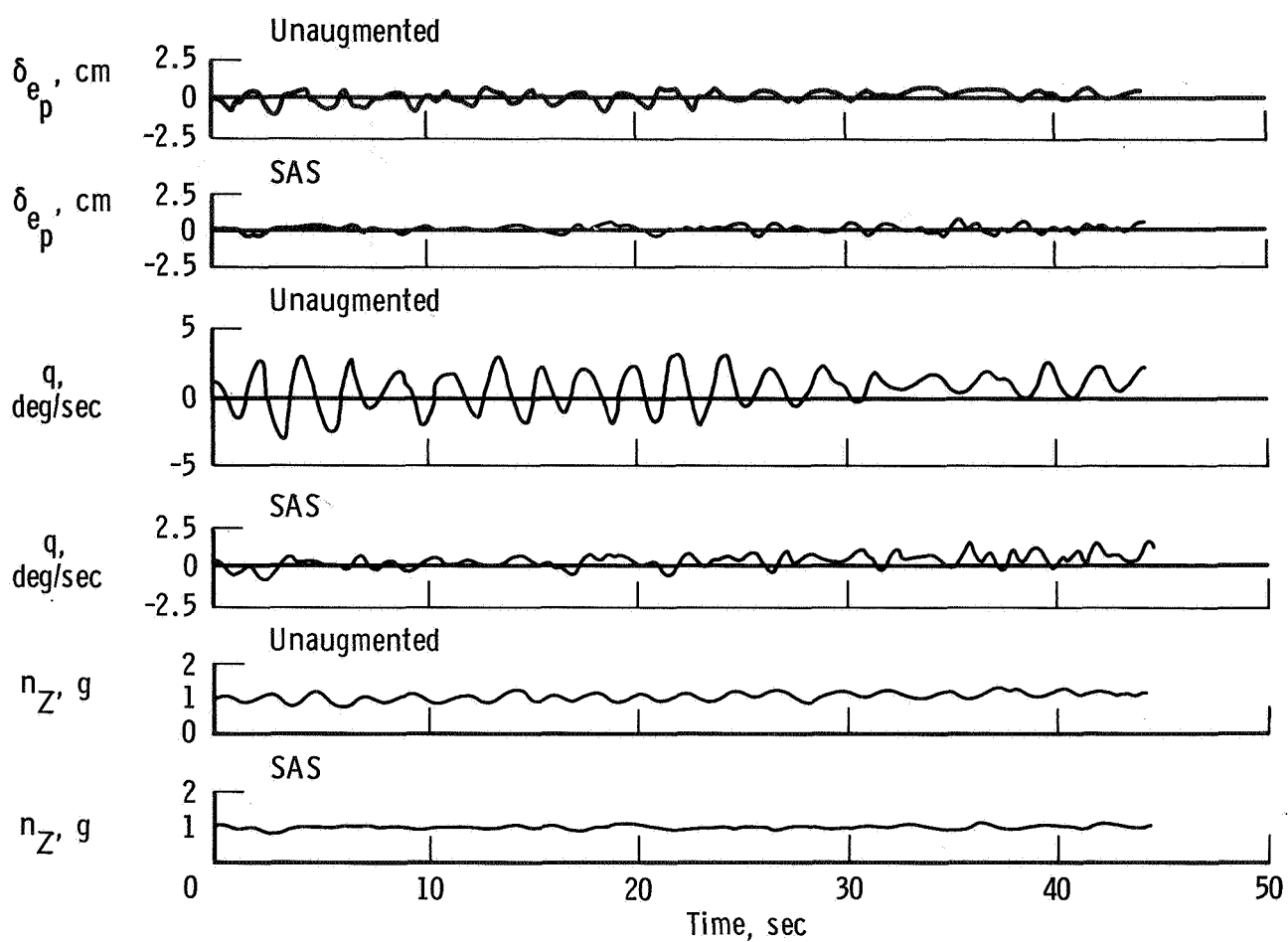
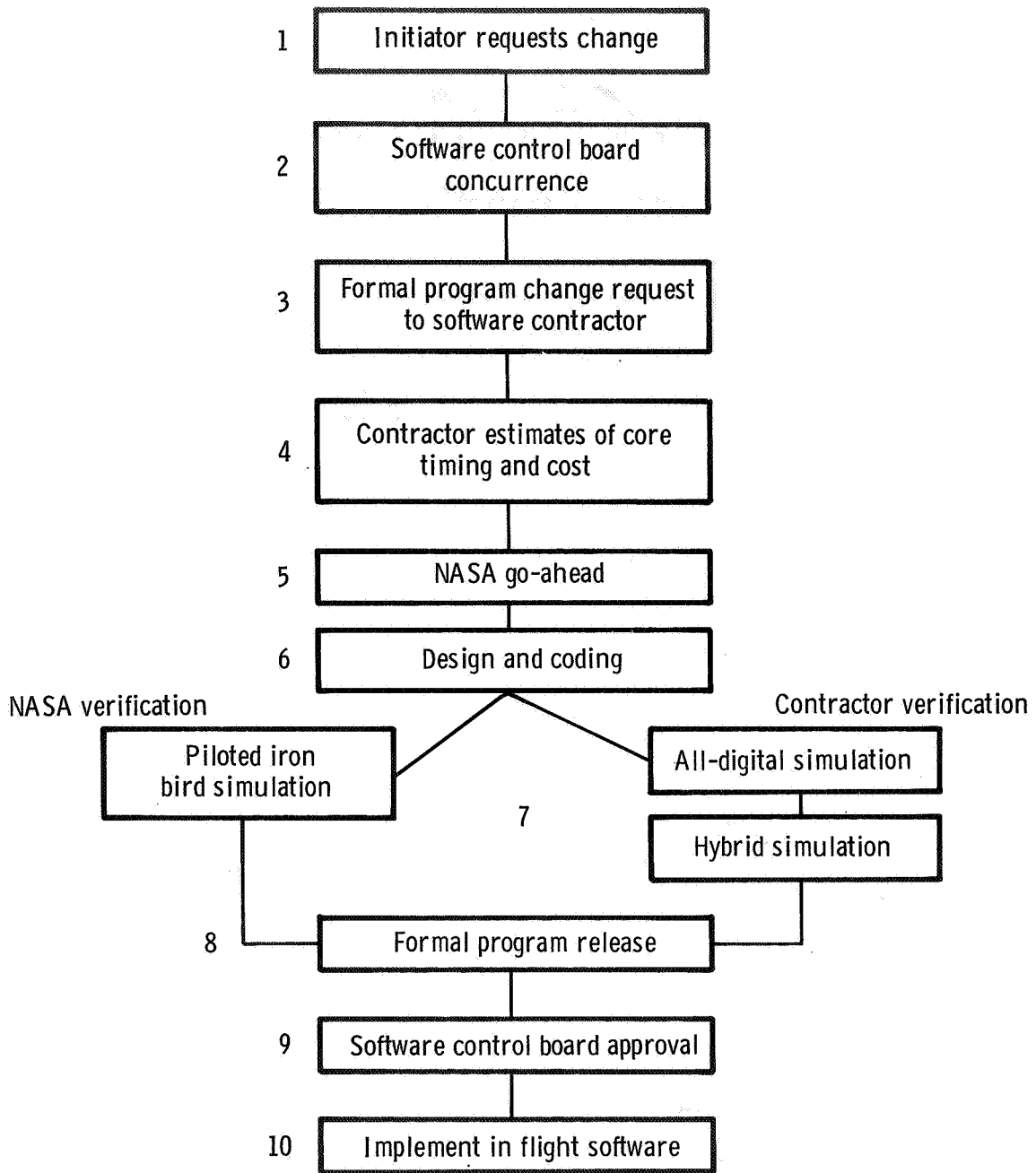
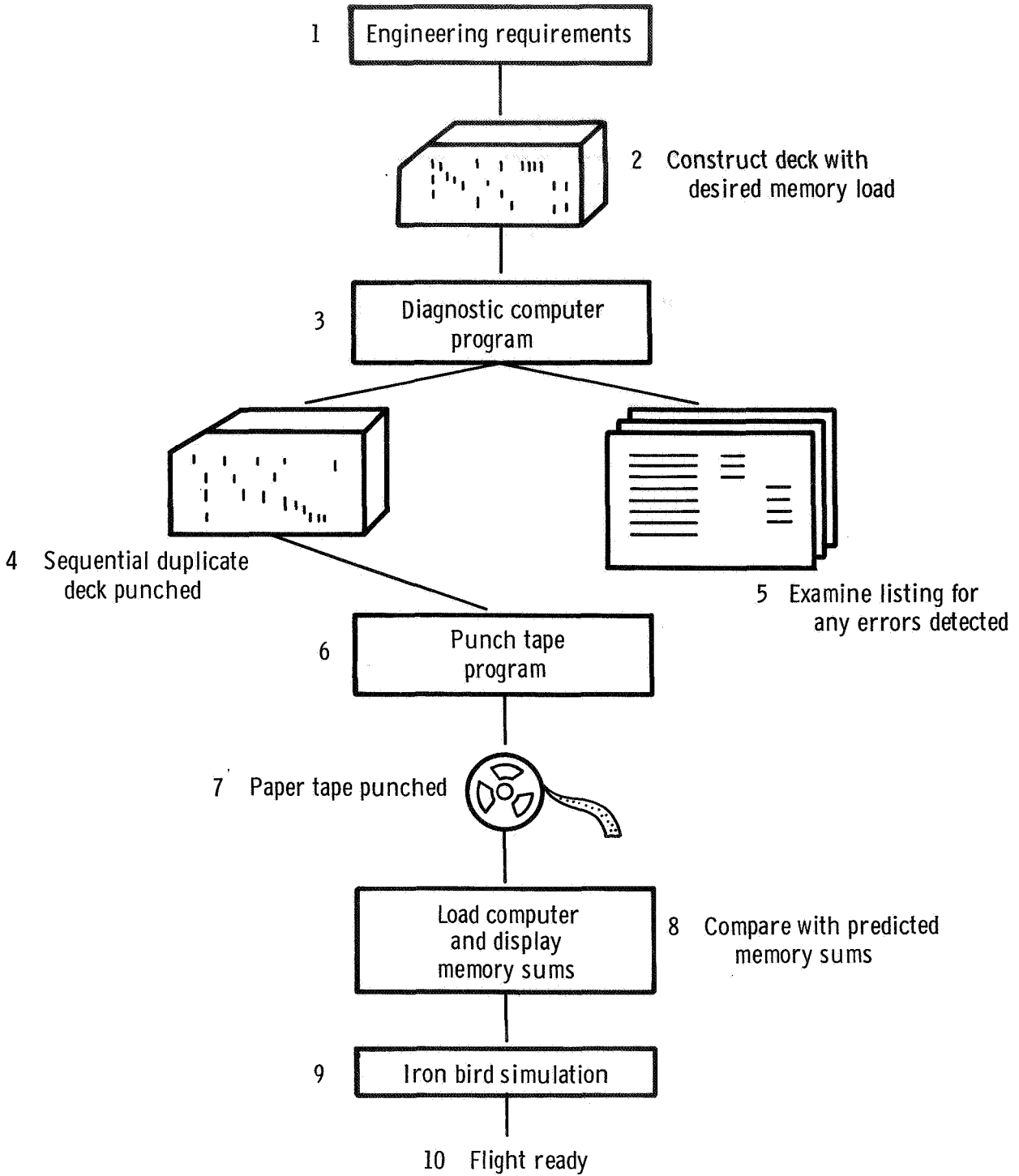

Figure 21. Pilot activity and airplane response in formation flight.



(a) Program change procedure.

Figure 22. Software management.



(b) Procedure for new erasable memory load.

Figure 22. Concluded.



## 7. A PILOT'S OPINION OF THE F-8 DIGITAL FLY-BY-WIRE AIRPLANE

Gary E. Krier  
NASA Flight Research Center

### SUMMARY

The handling qualities of the F-8 digital fly-by-wire airplane are evaluated by using the Cooper-Harper rating scale. The reasons for the ratings are given, as well as a short description of the flying tasks. It was concluded that the handling qualities of the airplane were good in most situations, although occasional ratings of unsatisfactory were given.

### INTRODUCTION

A standard F-8C aircraft was equipped with a roll damper, a yaw damper, and an aileron-to-rudder interconnect. The airplane had no pitch damper. Handling qualities were satisfactory throughout a large portion of the flight envelope.

This paper evaluates the airplane's handling qualities on the basis of the Cooper-Harper rating scale (ref. 1 and fig. 1) after the removal of the mechanical control links and the addition of the Apollo hardware digital fly-by-wire control system.

A force side stick controller was mechanized in the analog backup control system and was evaluated by using the same tasks as those used to evaluate the digital primary control system.

The yaw axis was not extensively evaluated, so results are not reported in this paper.

The primary purpose of the program was to expeditiously demonstrate the feasibility and reliability of a digital fly-by-wire control system for an airplane. The space-proved Apollo system was adapted to the airplane, forcing compromises that did not allow optimization of the airplane's handling qualities. Nevertheless, the handling qualities were mostly satisfactory.

## SYMBOLS AND ABBREVIATIONS

BCS	analog backup control system
CAS	command augmentation system
DIR	direct mode of control
q	dynamic pressure
SAS	stability augmentation system
x-plane	from wingtip to wingtip of a target aircraft
y-plane	from nose to tail of a target aircraft

## CENTER STICK HANDLING QUALITIES

### Takeoff

Takeoffs with the F-8 digital fly-by-wire airplane were normally made using the stability augmentation system (SAS) in all axes. This gave a well damped aircraft that handled turbulence effectively. Bank angle control was good and could be set quickly and relatively precisely. A pilot rating of 2 on the Cooper-Harper scale was given for the takeoff and climbout (figs. 2 and 3).

### Cruise

Control for cruising flight was easily adequate and is not further discussed in this paper.

### Gross Maneuvering and Aerobatics

Pitch and roll control for any moderate to high rate maneuver was similar in each flight control system configuration. Maneuvers performed with the backup control system (BCS), direct mode (DIR), SAS, and command augmentation system (CAS) appeared very much alike to the pilot, which suggests that these were not good tasks for an evaluation.

### Formation Flight

The ability to fly good wing and trail formation (fig. 4) is a requisite for fighter aircraft. It is also a task that rapidly exposes deficiencies in the flight control system. Poor control harmony between pitch and roll, poor damping, incorrect time constants, undesired force gradients, and other problems are all

revealed when the aircraft is put to the formation task. With a good formation-flight aircraft, vertical position can be held consistently within 30 centimeters and lateral displacement can be held as desired. The task rated with the F-8 digital fly-by-wire airplane was the ability to hold a close wing position and to assess the workload required to do it.

While the airplane was in the backup control system, pitch sinusoidal oscillations of  $\pm 60$  centimeters from a base position were caused by the slight delay in response to pitch stick inputs. Considerable pilot compensation was required to achieve even that amount of control. The response in the stability augmentation system was satisfactory but slightly sluggish because we were operating in the flat portion of the stick curve (fig. 5). Control in the direct mode was inferior to control with the stability augmentation system because of underdamped short period oscillations.

By far the most difficulty was encountered in trying to conquer the roll axis. Considerable attention was required on the part of the pilot any time formation was attempted in the roll backup control system or the direct mode. Response was objectionable because of small control deflections when low stick displacements were used and fast response when the apparent lag was overcome by using larger stick displacements. Using the roll stability augmentation system markedly improved the ability to hold close position, possibly because the stability augmentation system tended to initially oppose a rapid response to a pilot input. The stability augmentation system made the aircraft well behaved up to speeds where quantization became a factor.

### Tracking

Gunsight tracking with a fixed reticle (fig. 6) was flown because it was an excellent way to assess the response of the airplane to pilot commands. The film was analyzed frame by frame to determine the miss distance, which was referenced to the plane running through the target airplane's wingtips (x-plane) or to the plane running from the target airplane's nose to its tail (y-plane). This allowed control difficulties to be classified as either a lateral-directional or a pitch problem (figs. 2 and 3).

The pilot's ability to keep the gunsight aiming point (pipper) on the tailpipe of the target airplane in a dynamic, tight loop situation was the task rated.

Tracking in the pitch stability augmentation system was unsatisfactory unless considerable trim was used to return the stick to the flatter portion of the parabolic deflection curve. If the trimming was omitted, quantization and its accompanying short period oscillations caused pipper oscillation in the pitch plane. Tracking in the stability augmentation system with a trimmed stick was good enough to perform the mission without improvement. The same problems arose in the direct mode, but this mode was without pitch rate damping, and was thus rated moderately objectionable.

The pitch backup control system was by far the smoothest of the modes tested and afforded good pitch steering at all angles of attack. Some short period oscillations occurred, but they were not significant.

The difficulties were considerable in the roll axis. There was a definite tendency toward pilot-induced oscillations whenever precise, rapid corrections were required. This was evident in both the backup control system and the direct mode. The roll stability augmentation system reduced the magnitude of the problem, but its sensitivity degraded the airplane's ability to track precisely.

The fixed-ratio aileron-to-rudder interconnect produced slight proverse yaw during roll-in. This was considered desirable, since it provided a slight lead in the direction of the target.

### Ground-Controlled Approach

Ground-controlled approaches were flown using radar for positioning. This was an excellent task for the evaluation of precision control during tight loop instrument flight. Deviations from a preset position and altitude were radioed to the pilot, who then maneuvered the airplane back toward zero deviation. The response of the airplane to the pilot-initiated corrections was rated.

Pitch control was fair in the backup control system and the direct mode because of the short period oscillations generated by pitch corrections. Pitch response in the stability augmentation system was excellent, in that 30-meter-per-minute changes could be made in the rate of descent. Corrections in the pitch command augmentation system were initiated satisfactorily, but a distracting tendency to overshoot was noted that increased the pilot workload and therefore worsened the pilot rating.

Lateral control with low damping gains showed some deficiencies because of continuous low amplitude oscillations up to  $\pm 6^\circ$  of bank. No attempt was made to correct this deficiency during the flight test program.

### Landing

A portion of several flights was devoted to the assessment of the aircraft in various control modes in the landing pattern. The pitch backup control system was relatively smooth, and there was little tendency for the pilot to couple with the aircraft. In the direct mode, however, there was a tendency toward a pilot-induced oscillation during wing and gear transients. Sink rate control was fair with both of these modes. The stability augmentation system offered good pitch control throughout the pattern, with reduced transients and good flare control. The pitch command augmentation system was the best mode evaluated, but it masked the speed stability, which tended to lead the pilot to believe that changing stick force meant changing aerodynamic conditions; that was not always true.

Flare and touchdown control were satisfactory as long as a slight amount of back stick pressure was held to keep the airplane off the flat portion of the parabolic pitch curve. If this was not done, the delay in response caused firm landings or ballooning.

Lateral control in the landing pattern was characterized by low damping, overresponsiveness, and some periods of continuous low amplitude bank excursions.

The effects of these characteristics were reduced somewhat by consciously lowering the pilot's response and having him accept 1° to 2° deviations from the bank angle desired. This was considered moderately objectionable in itself, and coupled with a strong crosswind it became unacceptable.

The stability augmentation system reduced the airplane's response to gusts and small inputs and therefore it was rated better than the simpler control modes.

## SIDE STICK HANDLING QUALITIES

The side stick in the F-8 digital fly-by-wire airplane (fig. 7) was installed to ascertain whether a force side stick could be used to control an airplane during most phases of flight, especially takeoff and landing. No attempt was made to optimize the control parameters, although some changes were made for the flights near the end of the program. The side stick was mechanized in the analog backup control system, which had no dampers. A side stick takeoff was considered the most uncertain phase of flight and was therefore performed only after side stick control was evaluated in up and away flight.

### Takeoff

During side stick takeoffs, the pilot applied nosewheel steering (with the center stick) until rudder power was sufficient and then moved his right hand to the side stick. He made no inputs until lift-off speed was reached, when he applied a smoothly increasing pitch force to the stick. No lateral force was used near the ground to reduce the tendency for pilot-induced oscillations. Lift-off was smooth and similar to center stick takeoffs except that the pilot did not know the elevator and aileron positions through stick position (figs. 8 and 9).

### Gross Maneuvering

Gross maneuvering was easy with the side stick. Maneuvers such as large pitch attitude changes, wind-up turns, wingovers, and aileron rolls were performed without difficulty. Crosstalk between pitch and roll was not apparent.

### Formation Flight

Formation flight, a high pilot gain task, was enlightening during the early development of the F-8 digital fly-by-wire control system, when it exposed the severity of the task. Formation flight was also difficult with the side stick.

Loose wing formation flight could be satisfactorily performed with the side stick, although there were occasional random force pulses in pitch or roll. As the distance between the two aircraft diminished, the pulsing became more frequent and pronounced, indicating the tightening of the pilot in the loop. This resulted in a tendency for pilot-induced oscillations in pitch or roll or both with the system as it was mechanized, that is, without dampers and without attempts at optimization.

Some crosstalk (force interaction) was apparent during formation flight. Although its effect was not severe, it did start a disturbance in one axis while the pilot was trying to control the other axis.

### Tracking

Side stick tracking was typified by good to excellent control over the lateral-directional axis and continuous oscillations in pitch caused by pitch commands that were too abrupt and could not be smoothed. Crosstalk was absent in the tracking task.

### Ground-Controlled Approach and Landing

Power approaches from both pitch out and ground-controlled approach patterns were flown easily with the side stick. Roll control was good with respect to bank angle itself, but continuous left and right lateral force inputs had to be made. This did not degrade bank control, but it did drive the workload up quite a bit. Pitch control was precise.

Many of the approaches were flown in turbulence, which had little adverse effect on control.

Landings were characterized by final approaches that were well controlled down to the flare point. The flare was easy to initiate, and control was good almost to touchdown. Just before touchdown on every flight, the flightpath was stairstep-like. This was caused by pulsing pitch inputs from the pilot.

No large extraneous motion was generated by a simulated go-around if the trim kept the forces down to low levels.

### CONCLUDING REMARKS

The F-8 digital fly-by-wire airplane was generally well behaved throughout the flight envelope tested. Most of the handling qualities deficiencies encountered were a result of the original compromises made to adapt the Apollo system to the airplane. No extensive attempt to improve the Apollo-related deficiencies was made.

### REFERENCE

1. Cooper, George E.; and Harper, Robert P., Jr.: The Use of Pilot Rating in the Evaluation of Aircraft Handling Qualities. NASA TN D-5153, 1969.

*Flight Research Center  
National Aeronautics and Space Administration  
Edwards, Calif., September 25, 1974*

Controllable	Acceptable	Satisfactory	Excellent	1
			Good	2
			Fair	3
		Unsatisfactory	Some minor but annoying deficiencies	4
			Moderately objectionable deficiencies	5
			Very objectionable deficiencies	6
	Unacceptable	Major deficiencies which require mandatory improvement	7	
		Controllable with difficulty	8	
		Marginally controllable in mission	9	
Uncontrollable Control will be lost during some portion of mission		Uncontrollable in mission	10	

Figure 1. Cooper-Harper rating scale (ref. 1).

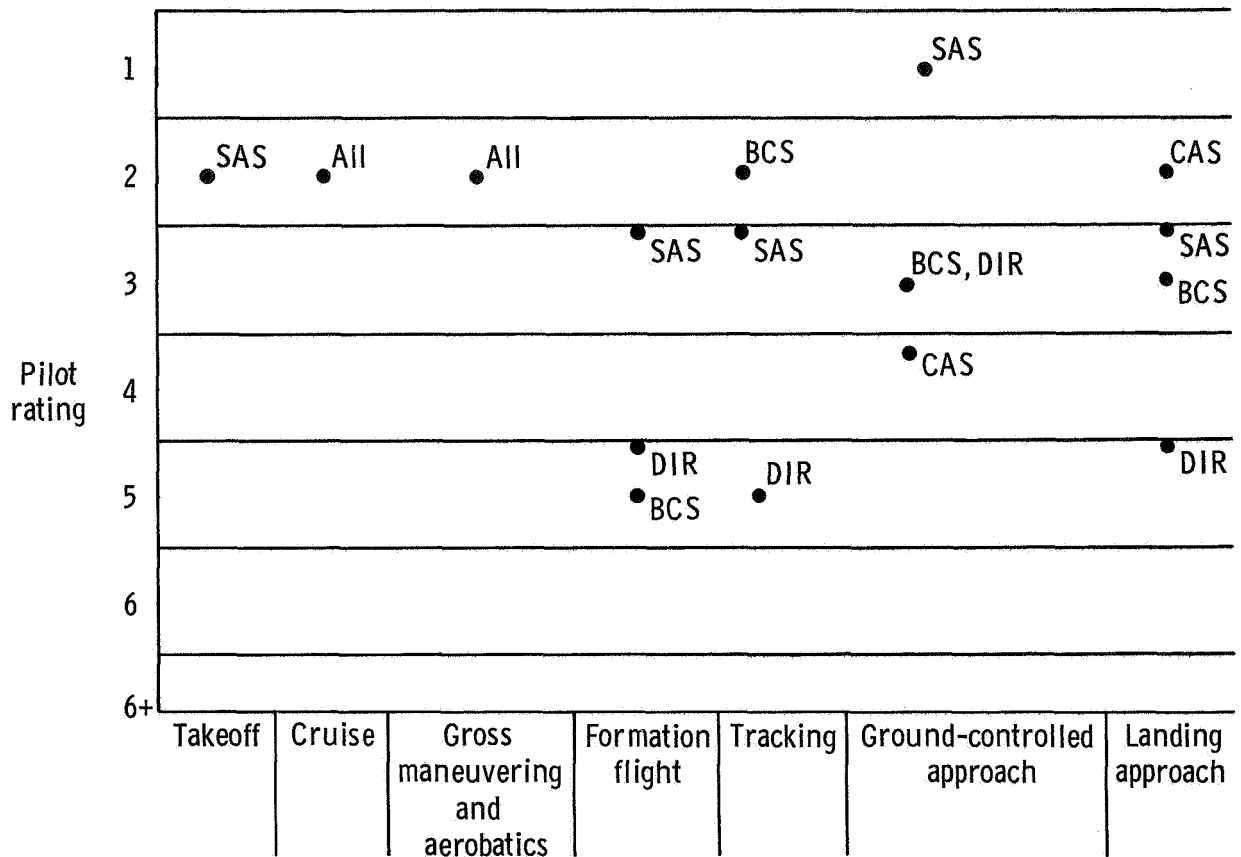

Figure 2. Center stick pilot ratings in pitch.



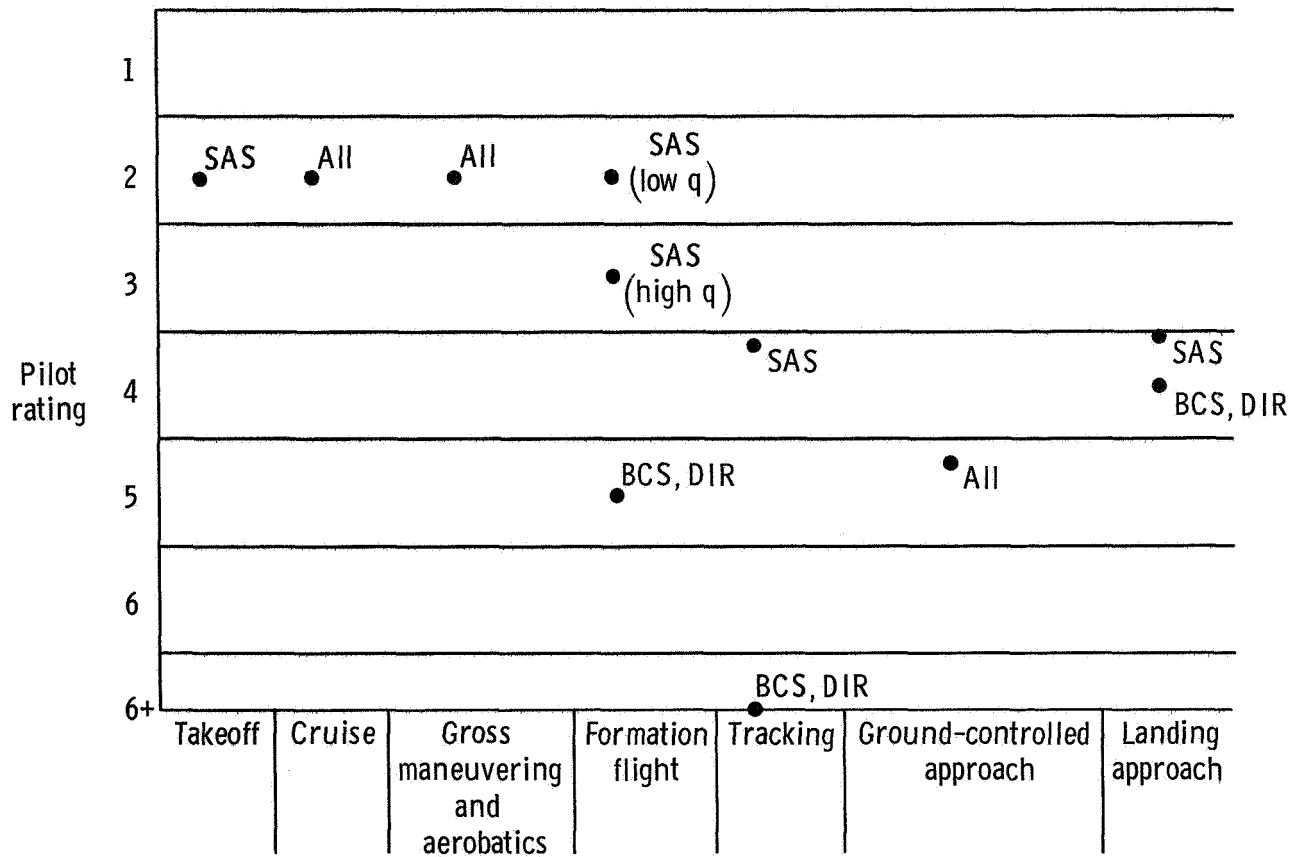

Figure 3. Center stick pilot ratings in roll.

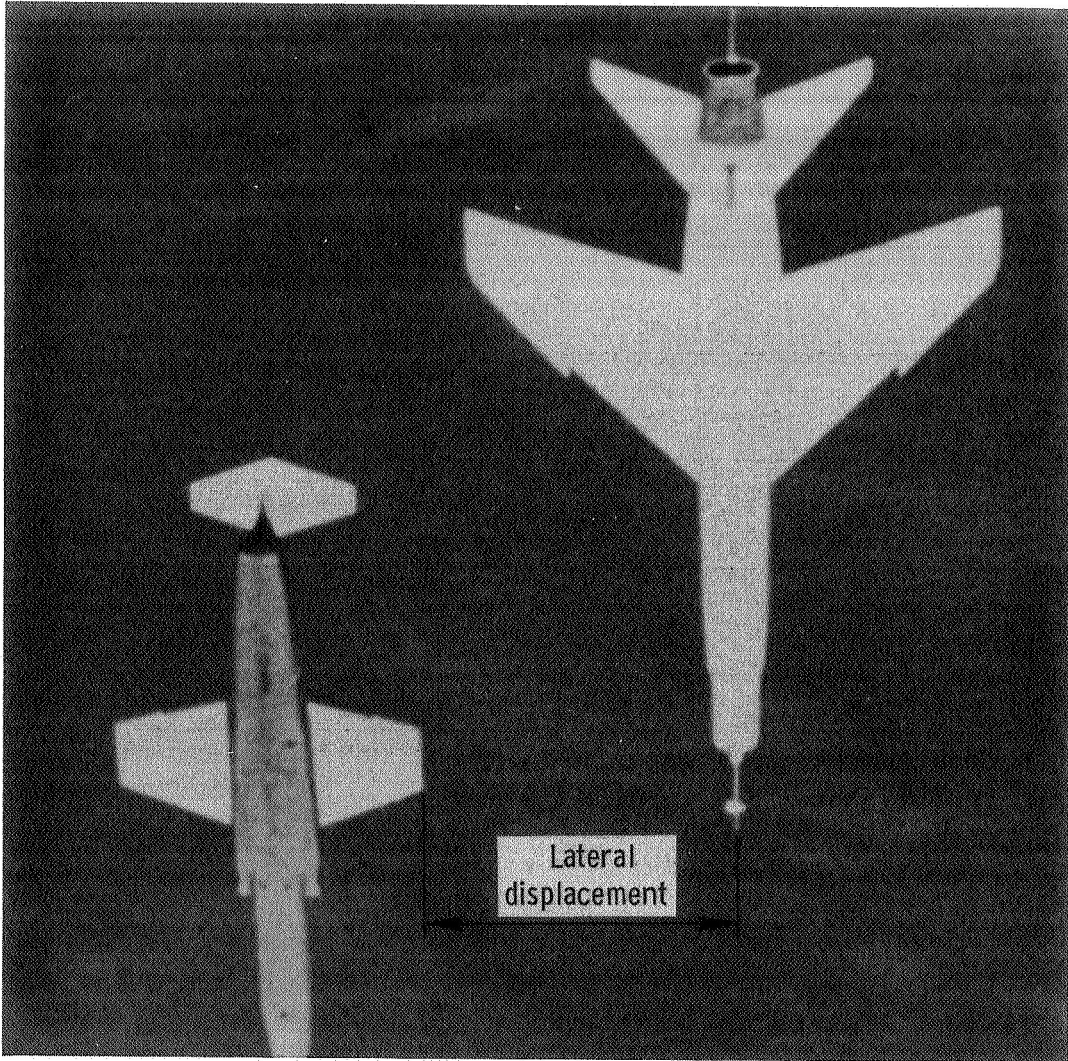

Figure 4. Formation flight.

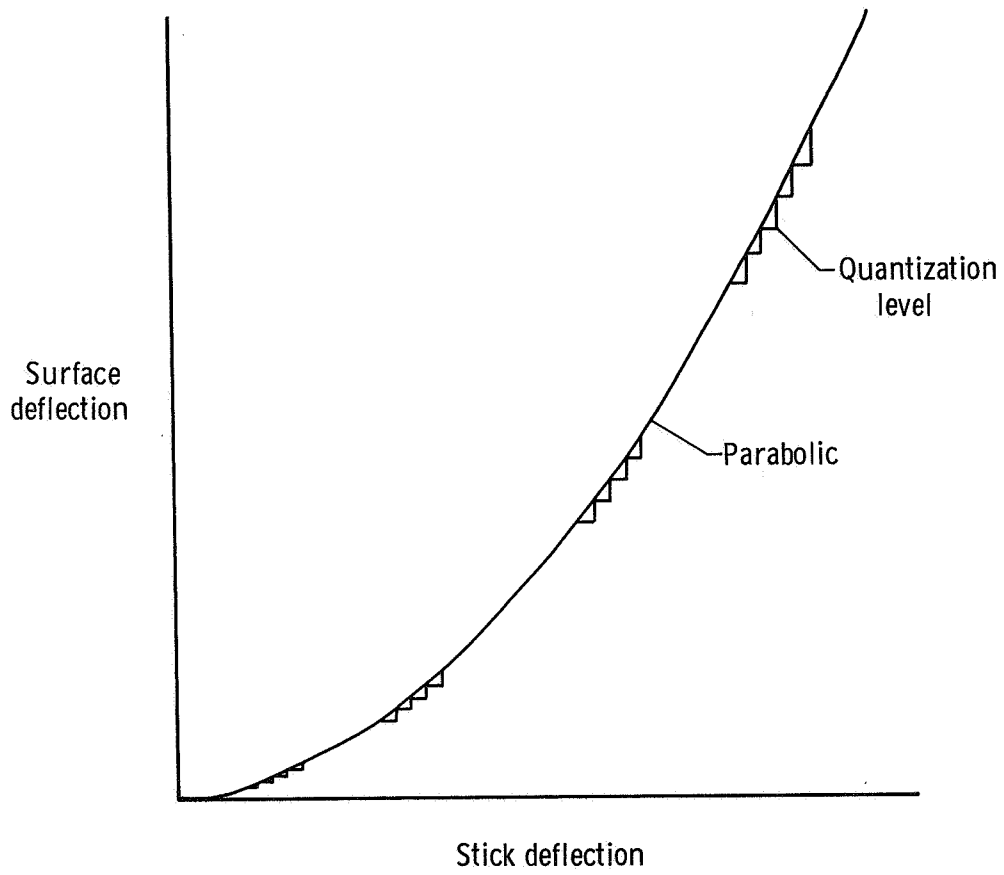

Figure 5. Control gearing.

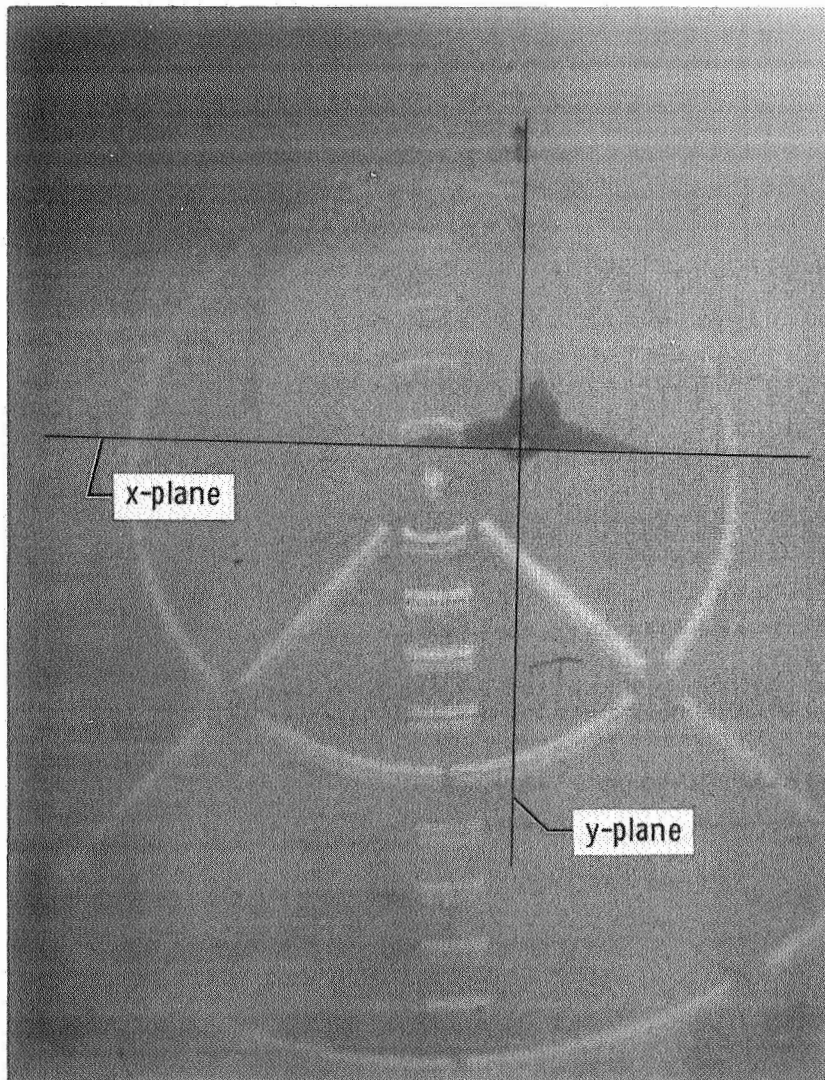

Figure 6. Gunsight tracking display.



Figure 7. Force side stick in F-8 digital fly-by-wire airplane.

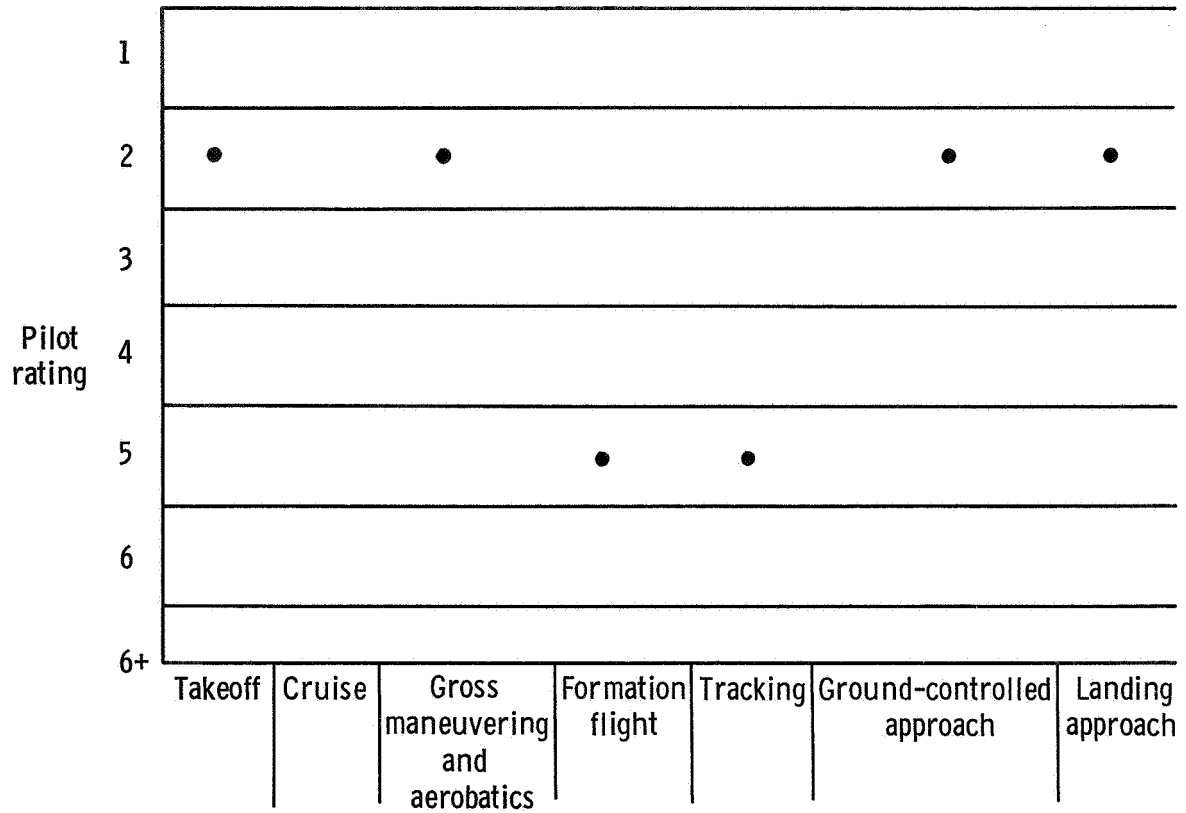

Figure 8. Side stick pilot ratings in pitch.

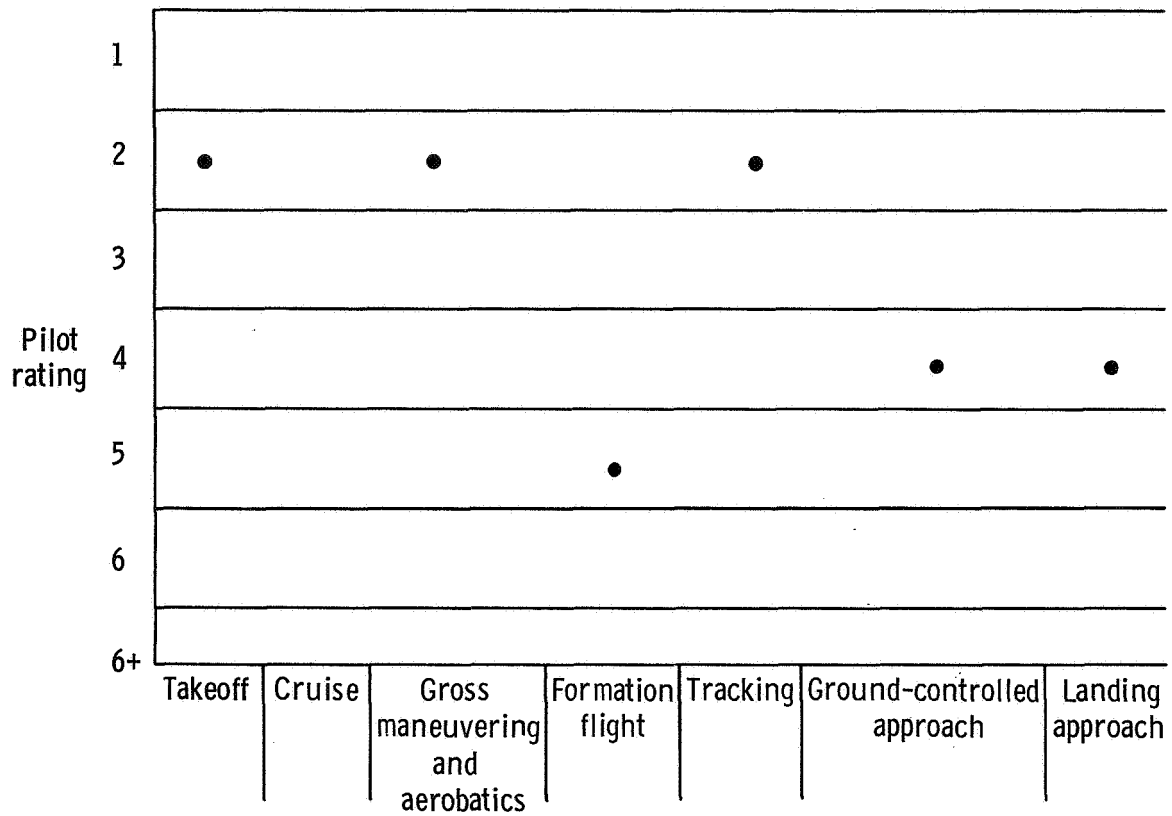

Figure 9. Side stick pilot ratings in roll.



POSTMASTER: If Undeliverable (Section 158  
Postal Manual) Do Not Return

*"The aeronautical and space activities of the United States shall be conducted so as to contribute . . . to the expansion of human knowledge of phenomena in the atmosphere and space. The Administration shall provide for the widest practicable and appropriate dissemination of information concerning its activities and the results thereof."*

—NATIONAL AERONAUTICS AND SPACE ACT OF 1958

## NASA SCIENTIFIC AND TECHNICAL PUBLICATIONS

**TECHNICAL REPORTS:** Scientific and technical information considered important, complete, and a lasting contribution to existing knowledge.

**TECHNICAL NOTES:** Information less broad in scope but nevertheless of importance as a contribution to existing knowledge.

**TECHNICAL MEMORANDUMS:** Information receiving limited distribution because of preliminary data, security classification, or other reasons. Also includes conference proceedings with either limited or unlimited distribution.

**CONTRACTOR REPORTS:** Scientific and technical information generated under a NASA contract or grant and considered an important contribution to existing knowledge.

**TECHNICAL TRANSLATIONS:** Information published in a foreign language considered to merit NASA distribution in English.

**SPECIAL PUBLICATIONS:** Information derived from or of value to NASA activities. Publications include final reports of major projects, monographs, data compilations, handbooks, sourcebooks, and special bibliographies.

**TECHNOLOGY UTILIZATION PUBLICATIONS:** Information on technology used by NASA that may be of particular interest in commercial and other non-aerospace applications. Publications include Tech Briefs, Technology Utilization Reports and Technology Surveys.

*Details on the availability of these publications may be obtained from:*

**SCIENTIFIC AND TECHNICAL INFORMATION OFFICE  
NATIONAL AERONAUTICS AND SPACE ADMINISTRATION  
Washington, D.C. 20546**