



NASA CR-134744
PSRI TR-4034

STUDY OF COMBUSTION EXPERIMENTS
IN SPACE

by: A. L. Berlad
State University of New York at Stony Brook

Clayton Huggett
National Bureau of Standards, Washington, D.C.

Frederick Kaufman
University of Pittsburgh

George H. Markstein
Factory Mutual Research Corporation

Howard B. Palmer
Pennsylvania State University

C. H. Yang
State University of New York at Stony Brook

under the aegis of
PUBLIC SYSTEMS RESEARCH, INC.

prepared for
NATIONAL AERONAUTICS AND SPACE ADMINISTRATION

NASA Lewis Research Center

Contract NAS3-17809



RECEIVED
MAR 1975
NASA STI FAC
INDOT RPA

DOCUMENT RELEASE AUTHORIZATION

NASA Scientific and Technical Information Facility P.O. Box 33, College Park, Maryland 20740		Control No. _____ Date: <u>December 6, 1974</u>		
D E S C R I P T I O N	TITLE: <u>Study of Combustion Experiments in Space</u>			
	AUTHOR(S): <u>Berlad, A. L.; Huggett, Clayton; Kaufman, Fredrich; Markstein, George, Palmer, Howard B.; and Yang, C. H.</u>			
	ORIGINATING ORGANIZATION: <u>Public Systems Research, Inc.</u>		COGNIZANT NASA CENTER Lewis Research Center 21000 Brookpark Road Cleveland, Ohio 44135	
	CONTRACT NO: <u>NAS3-17809</u>		SECURITY CLASSIFICATION: TITLE: <u>Unclassified</u> DOCUMENT: <u>Unclassified</u>	
	REPORT NO: _____			
	DATE: <u>December, 1974</u>			
	NASA CR NO: <u>134744</u>	WORK UNIT NO: <u>YOR6444</u>	NASA TECHNICAL MONITOR <u>Thomas H. Cochran</u>	OFFICE CODE: <u>5311</u>
	NASA TMX NO: _____			
THE FOLLOWING TO BE COMPLETED BY THE RESPONSIBLE NASA PROGRAM OFFICER OR HIS DESIGNEE				
(Further information is available in SP-7034 entitled R & D Reporting Guidance for Technical Monitoring of NASA Contracts)				
Document may be processed into the NASA Information System as follows:				
<input checked="" type="checkbox"/> May be announced in STAR (or CSTAR if a limited availability is checked below)				
<input type="checkbox"/> May not be announced (The attached letter may be consulted for information pertaining to the NASA non-announcement series)				
<input type="checkbox"/> May not be entered into the System because _____				
(Provide a brief statement to be quoted in answering requests for the referenced document)				
II. Document may be made available as checked below:				
<input checked="" type="checkbox"/> Publicly Available		<input type="checkbox"/> U.S. Government Agencies, NASA and NASA Contractors Only		
<input type="checkbox"/> Classified but Unlimited to Security Qualified Requesters		<input type="checkbox"/> NASA and NASA Contractors Only		
<input type="checkbox"/> U.S. Government Agencies and Contractors Only		<input type="checkbox"/> NASA Headquarters and Centers Only		
<input type="checkbox"/> U.S. Government Agencies Only		<input type="checkbox"/> Other Limitations (Specify) _____		
_____ _____		_____ _____		
Signature (Program Officer or Designee) 		Office Code: <u>5311</u> Telephone No. <u>433-4000, Ext. 6259</u>		
Date Signed: _____		TO: NASA Scientific and Technical Information Facility Attn: Acquisitions Branch P.O. Box 33 College Park, Maryland 20740		
MAILING LABEL → Use open window envelope or Clip out and paste				

1. Report No. NASA CR-134744	2. Government Accession No.	3. Recipient's Catalog No.	
4. Title and Subtitle STUDY OF COMBUSTION EXPERIMENTS IN SPACE 1-6-74		5. Report Date November 1974	6. Performing Organization Code
		8. Performing Organization Report No. PSRI TR-4034	
7. Author(s) A.L. Berlad, C. Huggett, F. Kaufman, G. H. Markstein, H. B. Palmer, C. H. Yang		10. Work Unit No.	11. Contract or Grant No. NAS3-17809
9. Performing Organization Name and Address Public Systems Research, Inc. 1320 Stony Brook Road Stony Brook, N.Y. 11790		13. Type of Report and Period Covered Contractor Report	
		14. Sponsoring Agency Code	
12. Sponsoring Agency Name and Address National Aeronautics & Space Administration		15. Supplementary Notes Project Manager, Thomas H. Cochran NASA Lewis Research Center, Cleveland, Ohio	
16. Abstract A study Group (SG) examined the physical bases and scientific merits of combustion experimentation in a space environment. For a very broad range of fundamental combustion problems, extensive and systematic experimentation at reduced gravitational levels ($0 < g < 1$) are viewed as essential to the development of needed observations and related theoretical understanding.			
17. Key Words (Suggested by Author(s)) Space Experimentation Zero Gravity Combustion Reduced Gravity Combustion		18. Distribution Statement Unclassified - unlimited	
19. Security Classif. (of this report) Unclassified	20. Security Classif. (of this page) Unclassified	21. No. of Pages 110	22. Price*

* For sale by the National Technical Information Service, Springfield, Virginia 22151

FOREWORD

The Study Group is indebted to the many members of the combustion community who gave generously of their time and effort in support of its work. Respondents to the Study Group's request for inputs from the combustion community are cited in the body of this report. We particularly wish to express our thanks to Dr. J. Swartz (PSRI, Stony Brook) and Mr. Tom Cochran (NASA, Lewis Research Center) whose diverse contributions to this study range from detailed scientific to the essentials of the Study Group's managerial and logistical requirements.

TABLE OF CONTENTS

I.	INTRODUCTION.....	8
II.	STUDY GROUP PARTICIPATION.....	13
III.	STUDY PROCEDURES AND CHRONOLOGY.....	15
IV.	FUNDAMENTAL AREAS OF COMBUSTION EXPERIMENTATION THAT WILL BENEFIT FROM BEING CONDUCTED IN A SPACE ENVIRONMENT.....	16
	1. Gas Jet Combustion.....	18
	2. Single Drop And Single Particle Combustion.....	29
	3. Combustion of Porous Solid Arrays.....	39
	4. Large Surface Solid-Gas Unpremixed Combustion.....	51
	5. Droplet Spray And Particle Cloud Combustion.....	56
	6. Source Ignition And Autoignition in Premixed Gases And Condensed Fuel Sprays.....	64
	7. Premixed Gaseous Flame Propagation And Extinction Limits.....	67
	8. Large Surface Liquid-Gas Unpremixed Combustion.....	77
	9. Experiments Performed In A Low- or Variable- Acceleration Environment.....	83
	10. Large Chemical Beam Combustion.....	86
V.	SOME COMBUSTION LABORATORY REQUIREMENTS.....	94
VI.	CONCLUSIONS AND RECOMMENDATIONS.....	96
VII.	APPENDIXES	
	1. Appendix A - "Specimen of Letter Used To Solicit Technical Views Of The Combustion Community".....	101
	2. Appendix B - "Minutes of the Three Meetings of the Study Group".....	103

SUMMARY

A study group (SG) examined the physical bases and scientific merits of combustion experimentation in a space environment. The effort included a broad solicitation of the technical views of leading researchers in the combustion community. Given the opportunity to engage in combustion experimentation which utilizes the space laboratory facilities of the Space Shuttle, the SG identified a broad range of combustion experimentation that is both urgently needed and inaccessible on earth.

The selection of effective reduced gravitational fields in a space laboratory implies the experimental control of "free convection" in combustion experimentation. This provides unique opportunities in the study of a broad range of basic fundamental combustion phenomena.

The space environment makes possible:

- (a) combustion experiments involving the selected coupling (and developing) of free convection to other transport processes
- (b) identification of the specific experimental roles of free convection in a wide range of combustion phenomena and, derivatively, the roles of other combustion sub-processes
- (c) systematic experimentation to determine the combustion characteristics of two-phase systems. These include individual particles and drops, clouds of particles and drops, arrays of solid fuel elements, large solid-gas and large liquid-gas combustible systems

- (d) experimentation to provide the observational bases for theoretical formulations where current theory is inadequate
- (e) selected experiments to provide specific answers to key questions for which $g=1$ experimentation is inadequate ($g =$ dimensionless gravitational constant)

Earth-based facilities for $0 < g < 1$ experimentation (e.g. drop towers) have an important role to play in future combustion studies. Nevertheless, this role is limited. Only an orbital space laboratory can provide the scales of time and space necessary to exploit substantially the scientific goals identified by the SG. These goals include the following areas of combustion research:

- (a) Premixed Flame Propagation and Extinction Limits
- (b) Theory of Noncoherent Flame Propagation
- (c) Upper Pressure Limit Theory of Ignition and Flame Propagation
- (d) Autoignition for Large Premixed Gaseous Systems
- (e) Cool Flames in Large Premixed Gaseous Systems
- (f) Burning and Extinction of Individual Drops or Particles, Over Very Large Ranges of Pressure
- (g) Ignition and Autoignition of Clouds of Drops and/or Particles, Over Very Large Ranges of Pressure
- (h) Two Phase Combustion Phenomena Involving Large Liquid-Gas or Solid-Gas Interfaces
- (i) Radiative Ignition of Solids and Liquids
- (j) Pool Burning and Flame Propagation Over Liquids

- (k) Flame Spread and Extinction Over Solids
- (l) Smoldering and Its Transition To Flaming (or Extinction)
- (m) Laminar Gas Jet Combustion
- (n) Coupling (or Decoupling) of Convectively-Induced
Turbulence Involved In Various Combustion Phenomena
- (o) Transient Responses of Flames To Time-Dependent
(Effective) Gravitational Fields.

I. INTRODUCTION

Background

In the Fall of 1973, the Lewis Research Center of NASA solicited proposals (RFP No. 3-574808) for a "STUDY OF COMBUSTION EXPERIMENTS IN SPACE". Under the aegis of Public Systems Research, Inc. (PSRI), a scientific Study Group was formed to respond to a most interesting set of charges. In part:

"This RFP is concerned with an overstudy of basic combustion experiments in space. ----The general objective of this procurement is to have recognized experts identify fundamental experiments that should be performed in a space environment--- . ---- It is not the intent of this study to use these experiments to support the Shuttle program. But rather, assuming that the Space Shuttle and potential space laboratory facilities exist, what basic experiments in combustion should be performed if the opportunity presents itself."

The PSRI-sponsored scientific Study Group that responded (successfully) to the RFP consisted of:

- A. L. Berlad, Chairman (State University of New York at Stony Brook)
- Clayton Huggett, member (National Bureau of Standards, Wash., D.C.)
- Frederick Kaufman, member (University of Pittsburgh)
- George H. Markstein, member (Factory Mutual Research Corp.)
- Howard B. Palmer, member (Pennsylvania State University)
- C. H. Yang, member (State University of New York at Stony Brook)

The background of concern in the committee's planning included the facts that

- (1) Although previous zero-g and related combustion studies had been performed (1-18) "---no concerted effort has yet been made to solicit suggestions for space experiments from the general academic and industrial research communities" (Ref. NASA RFP).
- (2) the constraints imposed by an (as yet) incompletely defined space laboratory could not be considered to be inflexible (19).
- (3) space laboratory experiments may be conducted largely during the 1980's, whereas related ground-based facilities (15, 20) are currently operative.

Accordingly, this study sought to encourage the widest interaction between the Study Group (SG) and the Combustion Community (both in the U.S. and abroad), and to make a critical, wide-ranging examination of possible fundamental bases for combustion experiments in a space environment.

In the following sections, we discuss the study methods employed by the NASA-PSRI sponsored Study Group, the interactions within the SG and between the SG and the scientific combustion community, the areas of fundamental combustion experimentation that are expected to benefit from being conducted in a space environment, the scientific bases for these expectations, and the currently perceived implications of these promising studies.

This report was prepared by members of the SG, but it also owes much to the scientific inputs by many individuals of the combustion community. The "Minireports" of Section IV were prepared (by the authors specifically noted) in behalf of the Study Group. All portions of the report reflect consensus views of the SG, derived according to the working procedures adopted (see Sections II and III).

References:

1. Andracchio, Charles R.; and Aydelott, John C.: Comparison of Flame Spreading Over Thin Flat Surfaces in Normal Gravity and Weightlessness in an Oxygen Environment. NASA TM X-1992, 1970.
2. Cochran, Thomas H.; Petrash, Donald A.; Andracchio, Charles R.; and Solos, Ray G.: Burning of Teflon-insulated Wires in Supercritical Oxygen at Normal and Zero Gravities. NASA TM X-2174, 1971.
3. Cochran, Thomas H.; and Masica, William J.: Effects of Gravity on Laminar Gas Jet Diffusion Flames. NASA TN D-5872, 1970.
4. Cochran, Thomas H.; and Masica, William J.: An Investigation of Gravity Effects on Laminar Gas-Jet Diffusion Flames. Thirteenth Symposium (International) on Combustion. Combustion Inst., 1970, pp. 821-829.
5. Cochran, Thomas H.: Experimental Investigation of Laminar Gas Jet Diffusion Flames in Zero Gravity. NASA TN D-6523, 1972.
6. Gaydon, Alfred G.; and Wolfhard, H.G.: Flames: Their Structure, Radiation, and Temperature. Third ed., Chapman and Hall, Ltd., 1970.
7. Edelman, R.B.; Fortune, O.; and Weilerstein, G.: Analytical Study of Gravity Effects on Laminar Diffusion Flames. Rep. GASL-TR-771, General Applied Science Labs., (NASA CR-120921), Feb., 1972.
8. Kumagai, Seiichiro; and Isoda, Hiroshi: Combustion of Fuel Droplets in a Falling Chamber. Proceedings of the Sixth Symposium (International) on Combustion. Rheinhold Publ. Corp., 1957, pp.726-731.
9. Hall, Arthur L.: Observations on the Burning of a Candle at Zero-Gravity. Rep. 5, Naval School of Aviation Medicine, Feb. 26, 1964. (Available from DDC as AD-436897).
10. Kimzey, J.H.; Downs, W.R.; Idred, C.H.; and Norris, C.W.: Flammability in Zero-Gravity Environment. NASA TR R-246, 1966.

11. Atallah, Sami; Bonne, Ulrich; deRis, John N.: The Flammability of Electronic Components in Spacecraft Environments. Factory Mutual Research Corp. (NASA CR-86106), Oct. 1968.
12. Bonne, Ulrich: Radiative Extinguishment of Diffusion Flames at Zero-Gravity. "Combustion and Flame". 16, 147 (1971)
13. Abduragimov, I.M.: Effect of Weightlessness on Diffusion Flame of Butyl Alcohol. Fiz.Goreniya Vryva, Vol. 5, June 1969, pp. 184-189.
14. Kimura, Itsuro; and Ukawa, Haruo: A Study of the Combustion of Laminar Fuel Jets. NASA TT F-13-459. Translated from Transactions of Japan Society of Mechanical Engineers, vol. 27, 1961, pp. 736-746.
15. Haggard, John B.; and Cochran, Thomas H.: Hydrogen and Hydrocarbon Diffusion Flames in a Weightless Environment. NASA TN D-7165, Feb. 1973.
16. Andracchio, Charles R.; and Cochran, Thomas H.: The Burning of Solids in Oxygen Enriched Environments in Normal and Reduced Gravity. NASA TMX-3055, May 1974.
17. Faeth, G.M.; Dominicus, D.P.; Tulpinsky, J.F.; and Olson, D.R.: Supercritical Bipropellant Droplet Combustion. Twelfth Symposium (International) on Combustion. Combustion Inst. 1969.
18. McMahon, J.F.; Kuwata, M.; and Essenhigh, R.H.: A Phenomenological Analysis of Unenclosed Laminar Jet Flames. Presented at Western States Section - The Combustion Institute. April 1971.
19. Naugle, John E. "Research With The Space Shuttle". Physics Today 26, 30 (November 1973).
20. Okajima, S; and Kumagai, S.: "Further Investigations on Combustion of Free Droplets in a Freely Falling Chamber, Including Moving Droplets." Paper No. 40, presented at the XV Symposium (International) on Combustion, August 1974, Tokyo, Japan.

II. STUDY GROUP PARTICIPATION

The five-month effort of the Study Group was predicated on substantial interaction with the combustion community. In addition to the membership of the SG (see Section I), the following Committee Associates participated directly in the formal deliberations of the SG:

Dr. Murty Kanury (Stanford Research Institute)

Professor P. Myers (University of Wisconsin)

Professor E. E. O'Brien (State University of N.Y. at Stony Brook)

Professor Roger A. Strehlow (University of Illinois)

Written and oral contributions concerning the scientific merits of Combustion Experiments in a Space Environment were derived from the following respondents:

David Altman
United Technology Center
Sunnyvale, Calif.

Dolph Amster
Navy Department
Washington, D.C.

W. H. Avery
Applied Physics Laboratory
The Johns Hopkins University
Silver Spring, Md.

J. M. Beer
University of Sheffield
England

David Burgess
U.S. Bureau of Mines
Pittsburgh Penna.

Richard Corlett
University of Washington

John De Ris
Factory Mutual Research Corp.

Ray Edelman
R&D Associates
Santa Monica, Calif.

Howard W. Emmons
Harvard University

G. M. Faeth
Pennsylvania State University

Edward A. Fletcher
University of Minnesota

Arthur Fontijn
Aerochem Laboratories
Princeton, N. J.

Raymond Friedman
Factory Mutual Research Corp.

Peter Gray
The University of Leeds
England

Joseph Grumer
U.S. Bureau of Mines

D. E. Herschbach
Harvard University

Murty A. Kanury
Stanford Research Institute

Arthur S. Kesten
United Aircraft Research Laboratories

Y. T. Lee
University of Chicago

John P. Longwell
Esso Research & Engineering Co.

L. A. Lovachev
Academy of Sciences
Institute of Chemical Physics
U.S.S.R.

John H. Macpherson
Chevron Research Co.

Philip Myers
University of Wisconsin

Lloyd Nelson
Sandia Laboratories

E. E. O'Brien
S.U.N.Y. at Stony Brook

A. K. Oppenheim
University of California
at Berkeley

Thomas Y. Palmer
U.S. Department of Agriculture

Richard Rothermel
U.S. Department of Agriculture

Robert F. Sawyer
University of California
at Berkeley

R. I. Scloukhin
U.S.S.R. Academy of Sciences
Novosibirsk

E. S. Starkman
General Motors

Roger A. Strehlow
University of Illinois at Urbana

Zoltan G. Szabo
L. Eotvos University
Budapest

T. Paul Torda
Illinois Institute of Technology

Stewart Way
Westinghouse Research Laboratories

Forman A. Williams
University of California
at San Diego

In most cases, respondents communicated with one or more SG member in writing. In many cases, individual members of the Study Group benefited from direct discussions with various colleagues. We apologize for any omissions in the previous listing. We again thank all respondents.

III. STUDY PROCEDURES AND CHRONOLOGY

The study objectives required that the most significant and potentially fruitful basic combustion experiments in Space be identified and critiqued. The Study Group was also to provide the pertinent scientific analyses, as well as recommendations regarding experimental priorities for the program. In pursuit of these objectives, broad interaction with the combustion community was planned.

The general procedures invoked included an initial one-day meeting (30 March 1974, at Stony Brook) to allow an exchange of views regarding the seemingly most promising areas for future study. At this meeting, lists of scientists to be contacted were generated. Each such scientist was contacted by an SG member, or by the committee acting through its chairman. A copy of the letter employed in this broad solicitation is shown in Appendix A. As a result of this first meeting, each member of the SG had his future contributions guided in that:

- (a) he knew which areas of experimentation were under consideration and what his special study responsibilities, in one or more of these areas, were.
- (b) he had an initial list of scientists whose views were to be solicited--and he knew who was to do the soliciting.

(c) he was to stay in contact with other members of the Study Group during the following several months, via phone, mail, and via additional two full-day meetings (3 June and 27 July, in Stony Brook).

Appendix B contains the minutes of the three full-day meetings. It is seen that these Study Group discussions were wide-ranging, that they were substantially enhanced by the direct participation of several guest scientists (Dr. E. Conway, NASA; Dr. M. Kanury, Stanford Research Institute; Professor P. Meyers, University of Wisconsin; Professor E. E. O'Brien, S.U.N.Y. at Stony Brook; Professor R. Strehlow, University of Illinois). It will be evident that the technical views to be reported herein evolved as a result of detailed study and broadly-based review and discussion.

IV. FUNDAMENTAL AREAS OF COMBUSTION EXPERIMENTATION THAT WILL BENEFIT FROM BEING CONDUCTED IN A SPACE ENVIRONMENT

Ten general (necessarily overlapping) areas of combustion experimentation embrace the specific fundamental studies which the Study Group believes will benefit from being conducted in a Space Environment. Each of these areas is discussed in the following portions of this section. In behalf of the Study Group, individual members have prepared each of these areas of promise, and for the assignment of experimental priorities, are presented therein.

IV. 1. Gas Jet Combustion

by H. B. Palmer

Discussion:

The literature on gaseous diffusion flames is vast. The references, however, cite only certain studies that bear particularly on the role of buoyancy and the effect of a zero-g environment upon gaseous diffusion flames (1-4).

Concentrated efforts on zero-g studies of laminar gas jet combustion (5,6,8,10-12) commenced in the late 1960's at NASA-Lewis, using their 2.2-sec drop tower facility. Experimental data from portions of this work have been compared with results of a rather detailed theoretical analysis by Edelman et al (9,10). Experimentation at Lewis is continuing, and analytical modeling is also continuing, at Imperial College in Spalding's group. The available free-fall time at the Lewis Research Center is now about 5 sec, in a new facility. We do not yet have information on results obtained using the new facility.

The role of gravity (i.e. buoyancy) in diffusional combustion has been appreciated for many years (see, e.g., the papers of Hawthorne and Hottel and that of Thomas) but has been difficult to study because momenta developing from density differences are usually small. The fluid dynamics of the laminar jet flame are usually dominated by the axial flow momentum of the fuel jet. On the other hand, the contribution of buoyancy effects in laminar gas-jet combustion normally is such that it has been difficult to describe experimentally the burning characteristics of a laminar diffusion flame that is free of buoyancy.

In short, efforts to sort out the relative contributions of forced and buoyant convection have generally been only moderately successful.

Thus zero-g or variable-g experiments on laminar gas jet combustion (ljc) are extremely valuable. The turbulent case is not of equal interest because forced convection dominates most such flames (but see the note on combustion of wooden cribs by Thomas, Ref. 2).

The NASA experiments on ljc reported to date have involved H_2 , CH_4 , C_2H_4 , and C_2H_6 as fuels burning in normal air and have utilized a considerable range of orifice sizes and volumetric flow rates. Observations were made by cinematography.

Striking differences in flame behavior for the different fuels were found. The start of an experiment, in which gravity changed abruptly from 1 g to 0 g, always produced a sudden reduction in flame length, followed by an increase in length with time and a change to an essentially spherical shape. Flame luminosity was much reduced. Heavy sooting was observed in the hydrocarbon flames (Fig. 1). Some flames eventually extinguished; others exhibited increasing flame length over the entire duration (2.2 sec) of the experiment; while in some instances, stable flames were achieved. The behavior depended on the fuel, the nozzle diameter, and the Reynolds number of the fuel; a summary appears in Fig. 2.

For the cases of stable flames at 0 g, correlations were found between dimensionless flame lengths (length/nozzle diameter) and characteristic parameters suggested by theory. These included the Reynolds and Schmidt numbers and the fuel mole fraction for stoichiometric burning. Likewise,

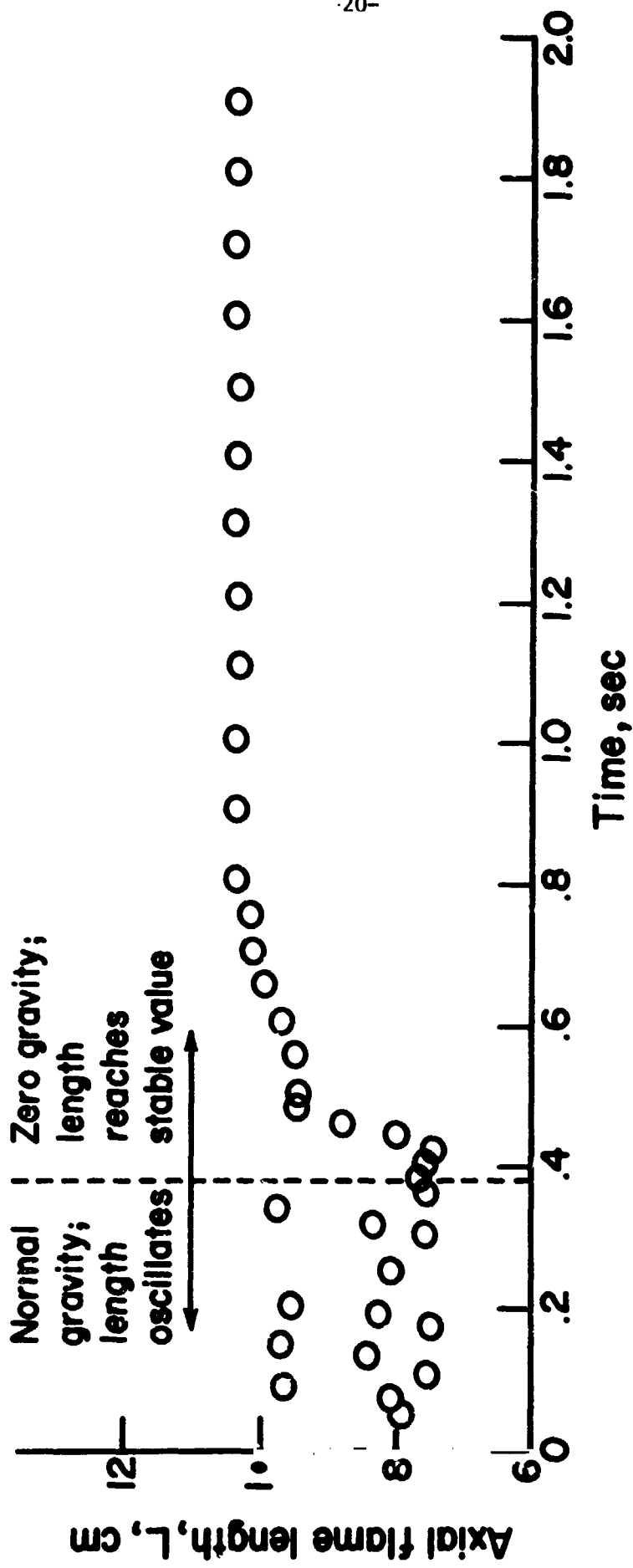

Figure IV.1.1.1. Typical time profile of axial flame length upon entry into weightlessness. (From Reference 12)

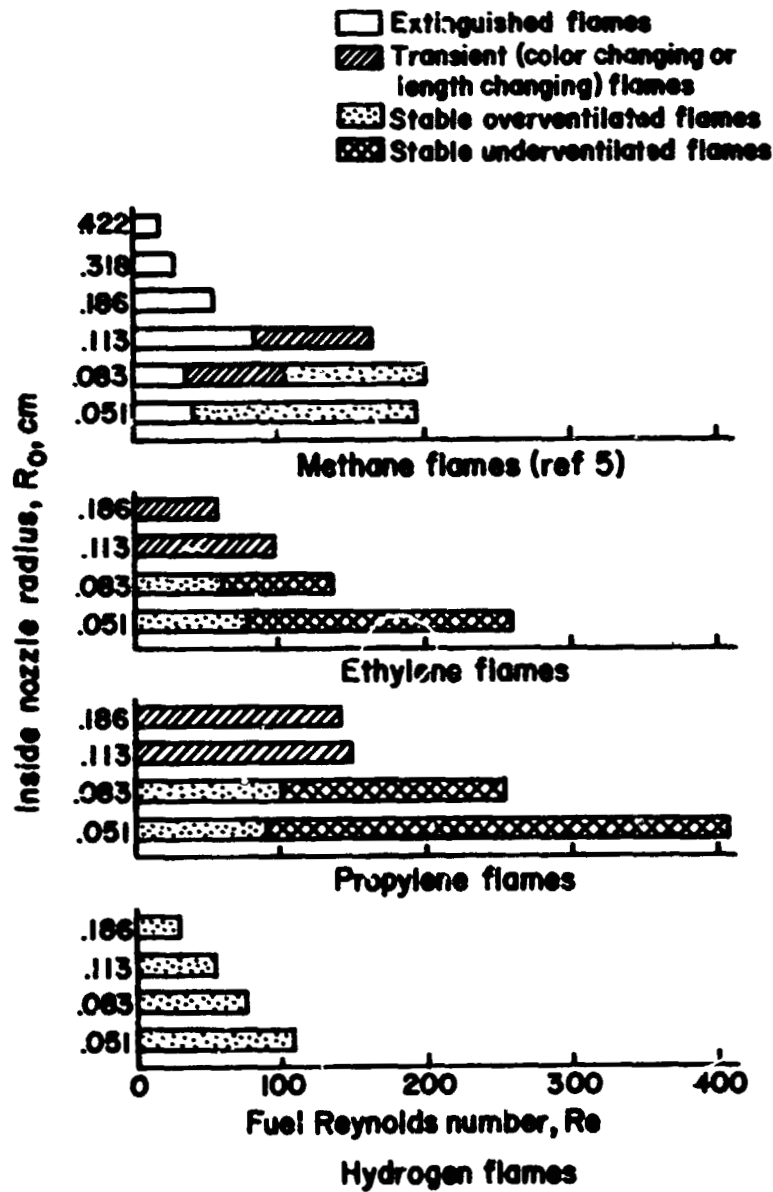

Figure IV.1.2. Flame conditions encountered in zero gravity as function of flow. (From Reference 12)

the dimensionless maximum flame radius was found to be in good agreement with an equation of Edelman et al (Ref. 9) involving g and the "fuel time" (the nozzle radius to the linear flow velocity of the fuel).

The success of these correlations indicates that the principal controlling parameters of l_{jc} at zero- g have been identified by theoretical considerations. However, a quantitative match between theory and experiment will require much more work, both theoretical and experimental. Edelman et al (Ref. 9) note that accurate theoretical predictions will require detailed consideration of the kinetics of the combustion process. They further note that the effect of oxygen concentration has not been examined experimentally, that variable transport properties will have to be taken into account, that axial diffusion has not yet been sufficiently considered, and that transient effects with changing g are particularly important at low Reynolds Numbers. We might add that no studies have been made of pressure effects, and of course the range of fuels examined has been very limited.

The transients, which may lead to extinguishment in some cases, are more difficult to analyze than the steady-state combustion. Since they are associated with the use of a drop tower, they can be avoided in an orbiting laboratory. In the orbiting laboratory, one can establish whether extinction is a consequence of the transients (i.e. essentially correlated by the ratio of a fuel residence time to the test time, transients being severe when the former is of the same order as or larger than the latter); or whether it is due to another factor. Bonne (Ref. 7) has reported an experimental and theoretical study that supports a radiative extinguishment mechanism for l_{jc} of methane, resulting from emission by CO_2 , H_2O , and soot.

Radiation from soot is especially important. His work suggests that extinguishment can occur even in a constant 0-g environment. Thus perhaps steady-state l_{jc} is not possible at 0 g under certain flow conditions. This important question should be explored. A complete understanding of it may require further theoretical work on transients, and would be facilitated by variable-g experimental facilities.

Of course the outstanding opportunity in the orbiting laboratory is a study of the structure of l_{jc} flames, which is impossible in drop-tests. Temperature composition (including soot formation), and radiation traverses (especially of flat diffusion flames) can be carried out and will add very significant information. Measurements of flame dimensions from photographs are very useful, but provide only limited understanding of the combustion process and a relatively crude test of theory.

Conclusions:

Our recommendations for experiments on l_{jc} in the orbiting laboratory include:

- Measurements of steady-state flame dimensions on the same flames studied in the NASA work.
- Extension of those studies by inclusion of flame structure measurements.
- Extension of different oxygen concentrations.
- Extension to lower and higher pressures.
- Extension to other fuel-oxidant combinations, particularly H₂- Br₂, for which the chemical kinetics and mechanism are quite well understood. (The toxicity of Br₂ may render this impractical.)
- Detailed studies of flame extinction (if it occurs), including use of soot-promoting additives and special radiating environments such as multiple flame burners.
- Variable-g studies of l_{jc}, if feasible, to examine (a) transients and (b) the relationship between forced and buoyant convection. (g₁ studies would also be useful here.)

It will be essential to couple these experiments with a continuing program of theoretical modeling, as well as continuing experiments with drop-test facilities.

References:

1. a. Hawthorne, W. R., Weddell, D. S., and Hottel, H. C., Third Symposium, Flame and Explosion Phenomena, Williams and Wilkins, Baltimore (1949), p. 266.
b. Hottel, H. C. and Hawthorne, W. R., *ibid.* p. 254.
2. Thomas, P. H.: Buoyant Diffusion Flames. *Combustion and Flame* 4, 381 (1960)
3. Kimura, Itsuro; and Ukawa, Haruo: A Study of the Combustion of Laminar Fuel Jets. NASA TT F-13-459. Translated from Transactions of Japan Society of Mechanical Engineers, Vol. 27, 1951, pp. 736-746.
4. Hall, Arthur L.: Observations on the Burning of a Candle at Zero-Gravity. Rep. 5, Naval School of Aviation Medicine, Feb. 26, 1964. (Available from DDC as AD-436897).
5. Cochran, Thomas H. and Masica, William J.: Effects of Gravity on Laminar Gas Jet Diffusion Flames. NASA TN D-5872, 1970.
6. Cochran, Thomas H. and Masica, William J.: An Investigation of Gravity Effects on Laminar Gas-Jet Diffusion Flames. Thirteenth Symposium (International) on Combustion. *Combustion Inst.*, 1970, pp. 821-829.
7. Bonne, Ulrich: Radiative Extinguishment of Diffusion Flames at Zero-Gravity. *Combustion and Flame* 16, 147 (1971).
8. Cochran, Thomas H.: Experimental Investigation of Laminar Gas Jet Diffusion Flames in Zero Gravity, NASA TN D-6523, 1972.
9. Edelman, R. B.; Fortune, O. and Weilerstein, G.: Analytical Study of Gravity Effects on Laminar Diffusion Flames, Rep. GASL-TR-771, General Applied Science Labs., (NASA CR-120921), Feb. 1972.

10. Edelman, R. B.; Fortune, O. F.; Weilerstein, G.; Cochran, T. H.;
and Haggard, J. B.: An Analytical and Experimental Investigation
of Gravity Effects Upon Laminar Gas Jet-Diffusion Flames. Sym. Comb.
14th, p. 399, The Combustion Institute, Pittsburgh, 1973.
11. Haggard, J. B., Jr. and Cochran, T. H.: Stable Hydrocarbon Flames
in a Weightless Environment. Combustion Sci. Tech. 5, 291 (1972).
12. Haggard, John B. and Cochran, Thomas H.: Hydrogen and Carbon
Diffusion Flames in a Weightless Environment. NASA TN D
Feb. 1973.

Respondents Comments:

Written comments have been received from two correspondents. They are reproduced below. Several of the interesting ideas therein have not been covered in the preceding discussion.

The following comments have been received from Dr. Ray Edelman of R & D Associates, Santa Monica, California:

The results of our study (Refs. 9, 10) suggest a couple of useful experiments that are not practical to conduct in drop tower facilities. The Space Shuttle would be ideal.

It would be useful to gather information on the influence of chemical behavior in laminar diffusion flames under zero-g conditions. The studies we were involved in indicated that the flame structure changed substantially from intense, relatively clean burning to "cool", sooty flames in going from normal-g to zero-g. In some cases quenching occurred. What is unclear at this time is the transient effect upon this behavior. (The transient I refer to is that which is inherent in the drop tower test.)

A simple experiment would involve attempting to ignite a jet of fuel while under established "zero-g" conditions. The configuration of significance here is one which quenched in the drop tower test.

For flames which did not quench it is desirable to define the change (if any) in the chemical structure of the flame. As indicated above, "cool" flame like behavior was observed in all of the zero-g flames which did not quench. (There may still have been a slow adjustment occurring which could not be delineated in the finite test time associated with the drop tower facility.) Our steady state calculations indicated relatively large flames with the same temperature levels as in normal-g could exist. Temperature measurements would be useful here (referenced to the normal-g flame temperature measured in an identical earthbound facility). Of course, species measurements would be rather nice to have. Not knowing what instrumentation will be available makes it difficult for me to put the above experiments into perspective. By referencing, say, simple thermocouple measurements to the ground-based normal-g flame would provide a useful relative measure of flame intensity. Errors associated with using a simple thermocouple could thereby be suppressed. A similar situation applies to sampling but this is a more difficult and more costly measurement. Of course, photographs and movies should be obtained. In general, the output of such basic experiments would not only be valuable for theoretical model comparisons, but would be of direct use in answering the serious question of flame intensity under zero g conditions. Repeating the above experiments in controlled, oxygen enriched, environments would be directly applicable to spacecraft applications. This would require encapsulating the experiment but should not pose any severe design problems.

The following comments have been received from Professor J. M. Beer, Head of the Department of Chemical Engineering and Fuel Technology, University of Sheffield, England. Professor Beer is reporting on informal discussions held with various colleagues at Sheffield:

The discussions obviously revolved around the question of what difference a zero gravity field would make to some of our combustion phenomena from two points of view: firstly, the combustion applications in space, and also identifying research problems where experiments would be carried out in a zero gravity field which would shed more light on details of combustion processes used here on earth. What strikes one first is that any combustion process which relies wholly or partly on buoyancy for the supply of one of the reactants will be significantly affected by the lack of gravitational acceleration, and any physical or chemical processes in which natural convection plays a role will be similarly affected. Thus, fires could not burn in a zero gravity field because the buoyant phenomena that provides the driving force for the supply of fresh reactant is missing. This will not affect, however, the burning of turbulent jets where the ratio of the buoyancy force to the force represented by the momentum flux at source is small. It is known, however, that density variations have a significant effect on the intensity of turbulence in jets, and it is also known that force fields can be used, particularly in connection with density gradients to damp turbulence. So, it would be of some interest to the experimental and theoretical fluid dynamicist to look at the spatial distribution of turbulence, its generation and dissipation in flows with density gradients in zero gravity fields. Where the velocity is low as in laminar flames, the effects are expected to be significant.

Following the studies Emmons has carried out on the fire whirl, we have studied a similar system where a pure turbulent diffusion flame was in the centre of a rotating screen. It could be shown that the radial density gradient coupled with the centrifugal force field could completely laminarise the flame. In all these experiments, in Emmons's and also in ours, the so-called Eckman boundary layer (a radial inflow on the base plate perpendicular to the rotating screen produced by the rotating environment) provided additional supply of oxidant to the fuel and I believe that this could substitute for the buoyancy in keeping a laminar jet flame or a fire going. I think therefore that a system of this kind would be a good candidate for combustion studies in the Space Shuttle Laboratory.

IV. 2. Single Drop and Single Particle Combustion

by H. B. Palmer

Discussion:

Literature on the burning of droplets is extensive. We cite four general references. In addition, four that relate to gravitational effects are also listed. These latter are the principal works known to the writer.

The opportunity to study burning of single drops and particles at near-zero gravity provides the means to explore several basic questions related to heterogeneous combustion. In experiments at 1 g, the burning of drops and particles usually is strongly influenced by natural convection. Only in the case of very small (diameter \leq microns) drops or particles, which are very difficult to produce and to study, does the effect of natural convection become slight. Classical theories of droplet burning have been developed assuming spherical symmetry (i.e. including neither natural nor forced convection) and quasi-steady conditions (essentially assuming that the rate of vaporization is small). Experimental studies of droplet combustion in falling chambers have produced almost spherically symmetric burning, but the duration of the experiments probably has not been adequate to establish the validity of the quasi-steady assumption. Furthermore, drop tests inevitably involve an abrupt change from 1 g to lower (usually zero) g. Transients are introduced into the combustion behavior in this process. Attempts to introduce corrections to 1-g observations that take into account natural and forced convection have been based on useful but approximate theoretical treatments and empirical correlations. They are not sufficiently reliable to permit a rigorous test of the basic convection-free theory.

Conclusions:

Thus essentially the availability of long-duration, near-zero g experiments should offer the chance to establish

- the existence or non-existence of quasi-steady droplet burning at zero g
- the accuracy of quasi-steady theories
- the effect of forced convection on burning rates
- the effect of natural convection (especially if variable- g conditions are available) on burning rates

Related or concomitant studies can examine

- flame structure (including flame radii for burning droplets and detailed structures for simulated droplets using porous spheres)
- effects of pressure and, perhaps, composition of the surrounding atmosphere (It has been suggested by at least one expert that the effects of pressure should be extended up to the critical conditions because of the importance of this in practical systems.)
- extinction of droplets as a function of droplet size, pressure, and other parameters
- effects of additives in the surrounding atmosphere
- vaporization of drops in the absence of combustion
- effects of drop-drop interactions (studies of small arrays, starting with two drops)
- formation of soot and NO_x during combustion of hydrocarbon droplets
- ignition delays and associate ignition transients

Opportunities in the study of solid single-particle combustion will be similar to those for droplets, in the sense that natural convection also affects particle flames when the particles are of substantial size (≥ 1 mm diameter). The additional complexities in burning of coal or metal particles (devolatilization,

formation of oxide layers, etc.) beyond those normally encountered in liquid droplet combustion suggest that study of drops may be the more fruitful. Droplet studies are much more likely to provide a definitive test of the idealized theory and thus to provide the foundation needed to construct a detailed model of burning in the presence of gravity. Nevertheless, the importance of particulate combustion is such that zero-g measurements of burning times certainly should be performed (thinking especially of coal particles), as a test of burning constant data obtained at 1-g conditions. [The burning constant is the constant K in the equation, $D_o^2 - D^2 = k(t - t_o)$, which is usually assumed to govern the burning of particles as well as drops. D is diameter and t is time. Actually, there is some question about the applicability of this relation to burning of coal particles. Removal of natural convection effects may elucidate this question.]

References:

A. General

1. Penner, S. S.: Chemistry Problems in Jet Propulsion. Pergamon, London (1957).
2. Wise, H. and Agoston, C. A.: Burning of a Liquid Droplet. Adv. in Chem. Series 20, 116 (1958).
3. Williams, F. A.: On the Assumptions Underlying Droplet Vaporization and Combustion Theories. J. Chem. Phys. 33, 133 (1960).
4. Williams, F. A.: Combustion Theory. Addison-Wesley Pub. Co., Reading, Mass. (1965).

B. Gravity effects

1. Kumagai, Seiichiro; and Isoda, Hiroshi: Combustion of Fuel Droplets in a Falling Chamber. Proceedings of the Sixth Symposium (International) on Combustion. Reinhold Publ. Corp., 1957, pp. 726-731.

2. Isoda, H. and Kumagai, S.: New Aspects of Droplet Combustion. Seventh Symposium (International) on Combustion, p. 523. Butterworths, London (1958).
3. Faeth, G. M.; Dominicus, D. P.; Tulpinsky, J. F.; and Olson, D. R.: Supercritical Bipropellant Droplet Combustion. Twelfth Symposium (International) on Combustion. Combustion Institute 1969.
4. Abduragimov, I. M.: Effect of Weightlessness on Diffusion Flame of Butyl Alcohol. Fiz. Goreniya Vryva, Vol. 5, June 1969, pp. 184-189.

Respondents Comments:

Comments and suggestions related particularly to droplet or particulate burning have been received from four well-known experts in the field. They underscore certain points made previously and include a number of additional ideas of considerable merit. Their communications follow:

• From Professor G. M. Faeth, Pennsylvania State University:

The major advantage of experimentation under these conditions is the absence of gravitational forces. This allows the elimination of natural convection effects which always tend to complicate the interpretation of combustion phenomena (since combustion intrinsically involves large temperature, and thus large buoyancy, gradients).

In the area of droplet combustion, the following possibilities could be considered.

1. The Structure of Droplet Combustion

The objective of this investigation would be to examine the detailed structure of the droplet combustion process. Of particular importance

would be the characteristics of soot and NO_x formation. Experimentally, this would involve the use of a porous sphere to simulate the droplet in order to eliminate transient phenomena during the study of the structure. Initial work could be accomplished most easily in a cold gas environment, advanced work might consider environments more typical of a combustion chamber. Capability for various total pressures (at least over a range of a few atmospheres) would be desirable.

For the cold gas environment, provision should be made for using a variety of gas compositions. In particular, low oxygen concentrations will cause the flame zone to lie further from the surface of the sphere so that structure can be measured more readily. It would also be desirable to examine the stability of this combustion process as the sphere size, oxygen concentration and total pressure was varied. Steady flame positions for various oxygen concentrations would also be useful for the theorists. The fuels considered should involve hydrocarbons, (cryogenics as well so that theoretical models can be tested on systems with relatively uncomplicated kinetics) including heavier hydrocarbons of technological importance.

The structure measurements should involve temperatures, species concentrations, soot concentrations, as well as the rate of gasification itself. For cryogenic materials, condensation of combustion products (particularly water) should also be considered.

With the steady, gravity-free test environment, data can be obtained for testing combustion models of diffusion flames in a simple configuration. Earth based experiments cannot accomplish this. While the use of very small droplets can minimize natural convection effects on Earth, the needed sizes are too small for the sampling and measuring requirements of a structure experiment. While opposed jet diffusion flames

provide a means of working at a reasonable size for structure measurements, convection and lack of one-dimensionality complicate the interpretation of these results.

This same arrangement (porous sphere) could also be used for stability and structure measurements of gaseous fuels, if external sphere cooling was provided.

2. Coal Particle Combustion

A study similar to the one described above, however, for coal particle combustion would have similar advantages for contributing to the understanding of this fundamental combustion process. In this case a truly steady combustion process could not be obtained since the fuel is consumed, however, the combustion rate of coal is low enough (and the reaction region sufficiently close to the surface) so that nearly quasi-steady conditions would be available for study.

3. Convection Effects for Droplets at Low Reynolds Numbers

An interesting extension of the experiment described in Part 1 would involve low Reynolds number droplet combustion. This condition is difficult to achieve on Earth since velocities must be kept high so that natural convection remains insignificant in comparison to forced convection phenomena (or conversely very small particles must be used). In the weightless environment, near zero Reynolds numbers can be considered. This regime will allow examination of the more complete convection theories of droplet combustion which are limited to the low Reynolds number regime. Porous sphere experiments, with flame shape as the most sensitive test of any model, should be used for simple, unambiguous, steady state results. The basic measurements would involve drag and gasification rate. The structure at low Reynolds number should also be measured, including

pollutant and soot concentrations. In this manner, the influence of incipient convection on kinetic processes could be examined for the sphere. Since the flow process is most easily analyzed under these conditions, these data would be most useful for developing models of the process.

Unsteady phenomena, and the effect of internal droplet circulation (or conditions for the appearance of circulation) could be examined using actual droplets with modest drift velocities.

From Professor F. A. Williams, University of California at San Diego:

Buoyancy usually is a dominant aspect of laboratory diffusion-flame combustion. Drop-tower attempts to remove it have produced unsteady flame structure. Only very small droplets seem to have spherical flames in the laboratory. A basic question that many have raised concerns the existence of quasi-steady diffusion flame droplets at zero g. I for one am convinced that they exist, although recent analyses (e.g., Waldman, IChE Symp.) suggest that unsteady conditions may be the rule. It would be very interesting to burn single droplets, sizes from 1 mm to 1 cm, in zero g in a chamber of the order of 100 cm in diameter, with care taken to avoid all nonspherical convection. The flame standoff distance (flame radius) should be measured and compared with classical theory. The pressure should be varied to verify that there is no pressure dependence (as predicted by theory); this has not been possible in earthbound labs, since pressure always influences buoyancy unless droplets are so small that it influences chemical kinetics. Pressures from 1/10 to 2 atm. would be reasonable, with air or oxygen-nitrogen or oxygen-argon mixtures containing less oxygen than air, being employed. (In pure oxygen, for example, flame temperatures are so high that dissociation complicates matters.)

The other question of interest is extinction. This gets at chemical kinetics (at least in an overall sense). It would be of interest to observe extinction radii of droplets as functions of pressure and to correlate these with Arrhenius expressions. The reason is that theory is much more precise in spherical symmetry, so results of greater accuracy can be obtained.

There are numerous other exciting things. Concentration profiles, temperature profiles, etc., could be checked against theory to improve understanding. Addition of retardants such as CF_3Br is interesting, both in respect to structure changes and in respect to extinction.

Small metal particles seem to be influenced very little by gravity on the earth. However, larger ones, 1 mm and up, would be quite interesting to study at zero g, with methods as indicated above.

Concerning droplets, I think that porous-sphere experiments would be interesting too. If steady state is not established with droplets, it surely should be with porous spheres.

From Mr. Lloyd Nelson of Sandia Laboratories, Albuquerque, New Mexico:

I see these areas of combustion science which might be benefited by weightlessness:

I. Combustion of arrayed solids or liquids -

These could be aerosols, particles, drops, filaments, coiled fibers and fire wires gauzes, etc., in gaseous or liquid oxidizers. Weightlessness would hold arrays, which would normally be physically unstable, in a fixed position for measurements (light scattering, optical measurements, etc.) prior to ignition and would keep products in position also.

Applications: dust explosions, photoflash devices, oil burners, propellants, pyrotechnics.

II. Combustion of Levitated Samples -

This would use fixed position of a sample, at very high temperatures if desired, to make careful measurements during the combustion. Sample could

be large or small, suspended in a liquid or gas, at high or low pressures. Applications: Optical measurements on burning metal drops, e.g. spectroscopy of burning particle at focus of a spectrograph, measurements of emittances during combustion of a metal drop; observation of nucleation phenomena during drop combustion, e.g. fog layer condensation, bubbling or explosions during combustion of a metal drop; separation of a phase, e.g. slag formation on surface of a decarburizing iron drop. Holography would be an interesting technique here because of its ability to observe self luminous objects.

III. Preparation of Molten Oxides at Very High Temperatures by Combustion

Could be used to prepare drops of oxides of metals with high solubility of oxygen e.g., rare earths, (Lu & Ac) Tc, Zn, Hf, at temperatures up to their boiling points. Careful control of stoichiometry would be possible.

Applications: Could be used for casting; quenching (splat cooling); interaction with solids (e.g. sealing leads) and liquids (e.g. thermal explosion); studies of mixed oxides by combustion of alloys; studies of oxynitrides, oxycarbides, oxyhalides by using mixed oxidizers; making measurements, e.g. density, surface tension, heat capacity, thermal conductivity; fiber spinning and so on.

From Professor M. M. Béer, University of Sheffield:

On the question of droplets or particles, there are again some rather obvious conclusions one may come to. Firstly a zero gravity field could provide an excellent experimental facility to study the combustion of droplets or particles with the complete absence of convection. One could also study the combustion of assemblies

of droplets and particles far below the terminal velocity of the cloud of drops or particles. It is known that convective currents in the liquid phase of an evaporating particle play a role in reducing the radial temperature gradient in the drop. Such currents would not exist in a zero gravity field. There is interest also in the effect upon the drag of the gravitational acceleration. It is known that drag coefficients of droplets and particles are affected by force fields acting upon them.

There are heterogeneous combustion systems which rely greatly on buoyancy. In a fluidised bed the density difference between the dense phase and the bubble phase plays a significant role in the mechanism of the process. The gravitational force field can be substituted by centrifugal force field and there are known attempts to make fluidisation work under such conditions. The possibilities of developing a centrifugal force field controlled fluidised bed system might be further investigated in a zero gravity field where one could look at the effect of very small centrifugal forces instead of the large ones we have to consider when on the earth's surface we want to make one force field dominant over the other.

IV. 3. Combustion of Porous Solid Arrays

by A. L. Berlad

Discussion:

Arrays of large numbers of solid, small fuel elements burn, with a gaseous oxidizer, in a coupled fashion. Within the nonisothermal array, each fuel element undergoes local vaporization and pyrolysis and the resulting effluents interact with the gaseous oxidizer to support a flame phenomenon of a physical scale that is much larger than the characteristic size of a typical fuel element. Examples of the many array materials that are of fundamental and practical combustion interest include cellulosic fibres (e.g. forest floor fire phenomena), synthetic fibres and foams (e.g. carpeting and mattress fire phenomena), and metal (or metal hydride) particle packed beds (e.g. hydrogen reservoir fire phenomena). Combustion studies that relate to the special features of this investigation are discussed in the references.

In the references, Experiment, Correlation, and Theory emphasize the role of free convection in array burning, or carefully select a special combustion case where the role of free convection is to be suppressed.

Figure 1 (reference 1) indicates an experimental array burning set-up for which free convection is clearly important. At reduced gravitational levels, it is expected that both the "burning rate" (mass loss rate per unit area of array) and the "spread rate" (rate of spread of the phenomenon over the combustible medium) would be different. The flame structure would be different also. Further, all of these characteristics (structure, burning

rate, spread rate) could be systematically varied by a selected series of variations of the gravitational field. Additionally, the array parameters which prescribe the extinction conditions for the figure 1 phenomena at $g = 1$ are expected to be characterized by numerically different (critical) values for $g < 1$. Figure 2 (reference 20) correlates the radiative ignition characteristics of cellulose at $g = 1$. Here, convective transport plays a role in the evolution of the quasi-steady flame structure, during ignition at $g = 1$. Were variations in g ($g < 1$) to be carried out, one may expect major changes in the characteristic appearance of Figure 2. Figure 3 (reference 7) shows the characteristic downward propagating structure of a $g = 1$ flame supported by a (structurally collapsing) sheet of paper. Clearly, both the combustion and structural collapse characteristics are expected to be profoundly altered as $g \rightarrow 0$ from $g = 1$.

Typically, experimental arrangements for the study of the combustion of various condensed phase arrays emphasize a diversity of purposes: the rate of flame propagation over (and through) a cellulosic array, as a function of array surface inclination, array density, ambient wind conditions, moisture content, gas phase composition, etc; the temperature structure of a fire spread wave; the critical oxygen index, moisture content and bulk density for quasi-steady flame propagation; the effect of radiation on ignition and/or flame propagation; the effects of pressure, characteristic dimensions, gravitational and/or other accelerating fields on flame propagation rates; the fundamental effects and practical utility of chemical inhibitors and quenching agents; the wish to delineate the interplay of molecular, turbulent, convective and radiative transport phenomena; the need to understand fundamental chemical kinetic processes.

COMBUSTION LABORATORY INSTRUMENTATION FOR STEADY STATE FIRES

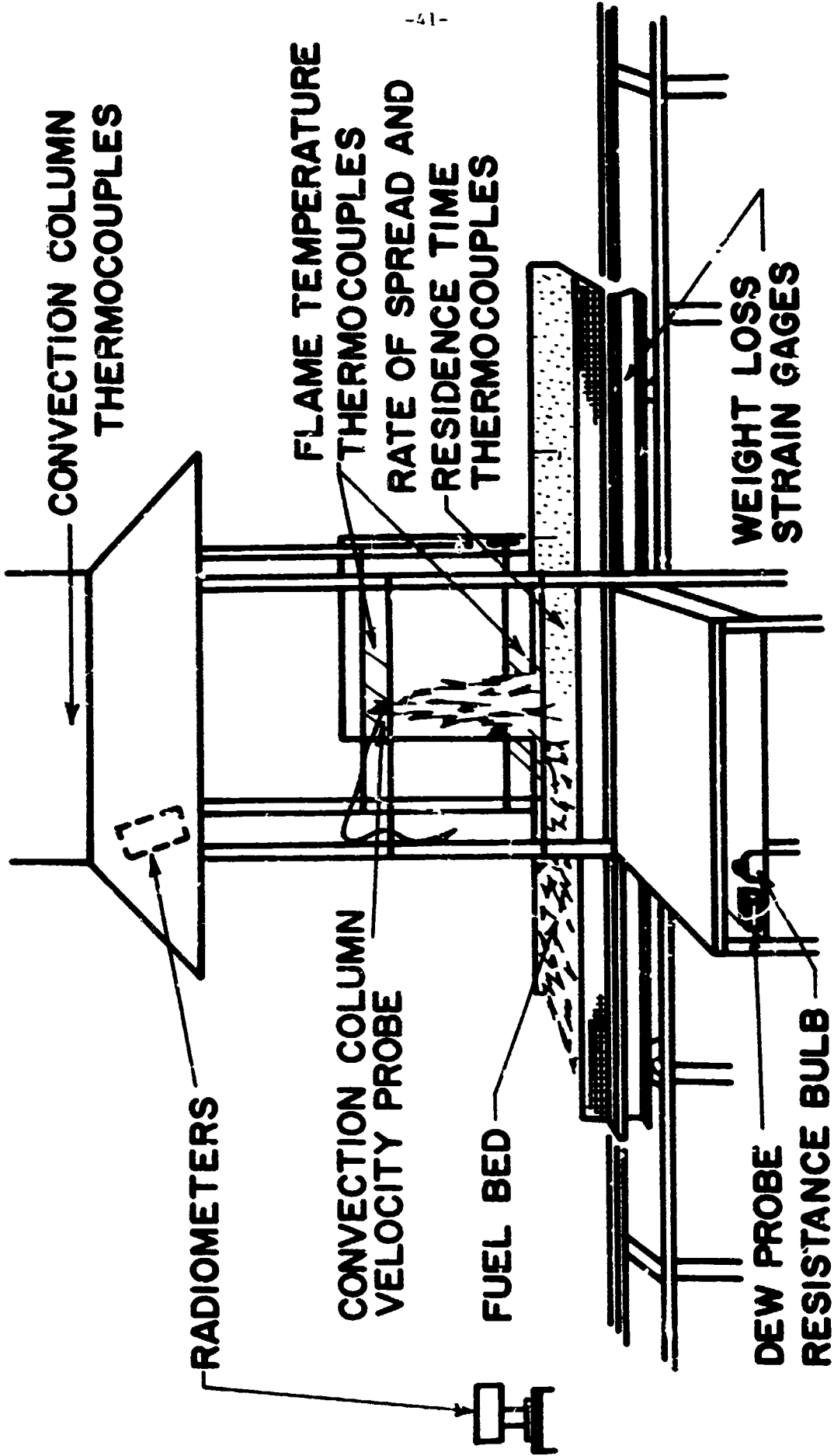

Figure IV.3.1. Instrumentation used in the combustion laboratory. A similar arrangement was used in the wind tunnel testing.

(From Ref. 1)

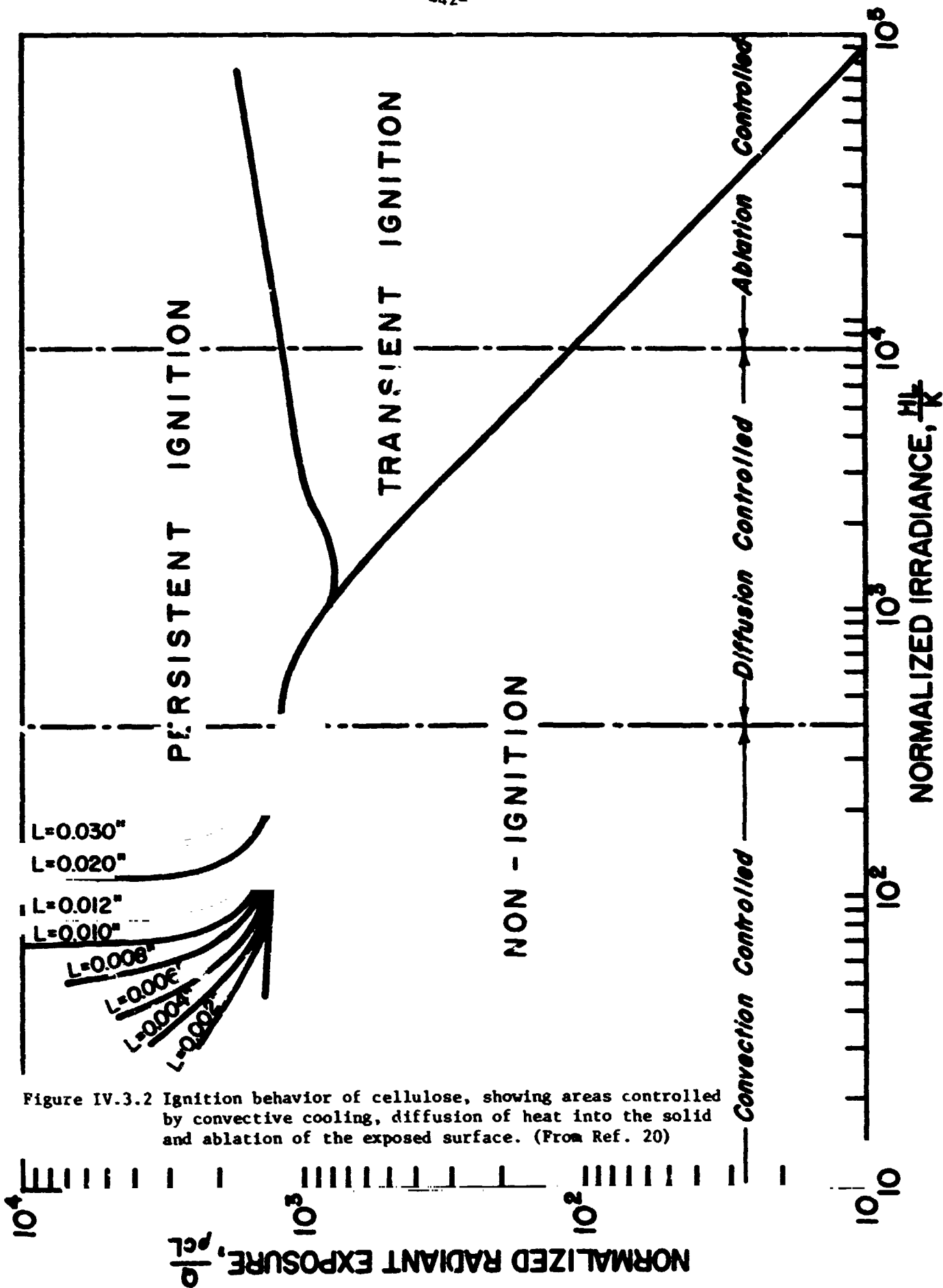

Figure IV.3.2 Ignition behavior of cellulose, showing areas controlled by convective cooling, diffusion of heat into the solid and ablation of the exposed surface. (From Ref. 20)

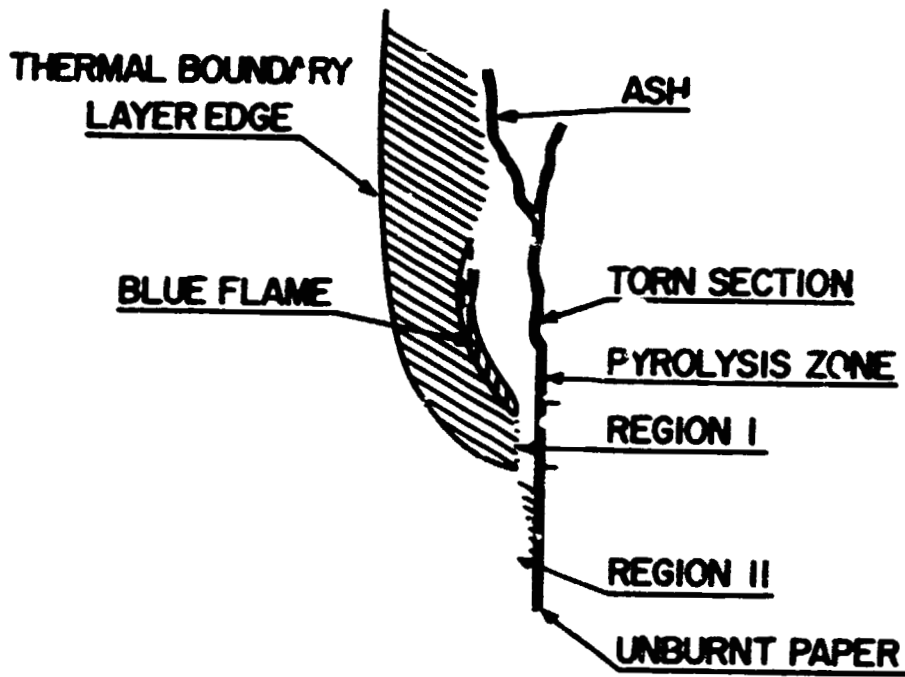

Figure IV.3.3. Detail in the vicinity of the downward spreading flame.
(From Ref. 7)

These experiments, performed in normal (1-g) gravitational fields, strongly display the effects of free convection. The dominant feature of a large stationary forest fire is the convective plume. The contrasting flame structures of "upwards" vs. "downwards" propagation, a "rising strand" of smoke so characteristic of a small, smoldering fire, the phenomena of "ceiling fires" and "room flash-over" all imply strong convective effects in normal (1-g) gravitational fields. Current theoretical and experimental results show the burning of solid arrays to be extremely complex phenomena. Free convection, couples with a diverse range of transport, kinetic and fluid mechanical processes to prescribe the usual experimental observations. The theoretical burden of simultaneously accounting for all these interacting processes has generally proved insuperable, to date. This is particularly true of the criticality conditions previously cited (ignition, extinction, smoldering transition).

Limited combustion experimentation under reduced gravitational fields has been carried out (e.g. References cited in Section I). Some observations of flame propagation, extinction, ignition, and reignition in varying g-fields have been reported. Nevertheless, there are no acceptable theories or definitive experiments which enable an investigator to:

- (1) predict the structure of smoldering combustion, and to predict the critical conditions for the transition to flaming combustion and the transition to extinction.
- (2) predict the relative roles of free convection, radiation, molecular transport, oxidative and pyrolysis kinetics in determining flame spread rates and extinction associated with porous solid arrays. (e.g. vary array thickness and optical aspect ratios).

- (3) evaluate, by a predictive theory, the utility of a chemical flame inhibitor. By definition, such an inhibitor affects the chemistry of one or more important combustion subprocesses. But the coupled processes (item 2, above) and their interactions have not been unraveled (e.g. vary moisture content, halogenated or other agent content. Determine extinction conditions).
- (4) construct a set of material hazard characteristics which reflect the chemical and physical properties of the considered materials rather than the (1-g) burning of a given sample (e.g. autoignition characteristics of arrays).
- (5) prescribe, in a radiative ignition experiment, the transition to steady burning via the time-dependent inclusion and coupling of the other transport processes (e.g. detailed flame structure measurements during the ignition process).

These deficiencies typify the current state of our limited understanding of the ignition, burning, and extinction of solid arrays of fuel elements. Truncated theories are useful in the correlation of limited data regimes, but the data we currently work with are at normal (1-g) conditions. The dominance of Grashof number (Gr) correlations for array burning suggests the deficiency of our understanding at small values of this parameter ($Gr \rightarrow 0$ as $g \rightarrow 0$).

The structural properties of array materials are not generally recognized in our analytic interpretations of combustion experiments.

Yet, the structural collapse of paper sheets, cellulosic fibres, etc., during combustion degradation of the burning material is well documented. This structural collapse at normal (1-g) conditions is quite different than that to be expected at other gravitational conditions. Inasmuch as the array structure strongly influences its combustion properties, experimental variation of gravitational fields in combustion experimentation may be expected to help define such effects.

Our current understanding on the combustion of porous arrays of solids may be thought of as limited and fragmented. The question of the utility of variable gravitational field experimentation (particularly in the neighborhood of zero-g) relates critically to the possible provision of current unavailable fundamental information. Under (zero-g) conditions, arrays may be studied whose (1-g) structural integrity (or lack of) makes combustion experimentation difficult, presently. In fact, arrays that may prove to be "fire hazards" in a "space environment" may include many of just such a class.

Conclusions:

Most important, then, zero-g experimentation permits the suppression of free convection effects. With this in mind, a promising program of reduced-g combustion experiments involving arrays of solid fuel elements is anticipated.

- (1) smoldering combustion. Does it exist (stably) at zero-g? At other low values of g? What are the experimental conditions for transition to extinction or to flaming combustion? What role is played by forced convection?
- (2) ignition. Radiative (or other) ignition of an array implies the rapidly growing interplay of various transport processes. What dynamics results, for the reduced (or eliminated) free convective conditions?
- (3) flame spread, inhibition, and extinction. Flame spread supported by a range of forced convective fields at zero-g. What are the limits on existence of such flames? What combustion roles are played by radiative and molecular transport? What "oxygen index", moisture content, or inhibitor concentration is critical to existence/nonexistence? Why?

These and related experiments await the availability of a space-orbiting combustion laboratory. The few seconds of experimental time available in drop towers is inadequate for this kind of experiment. The extreme case, smoldering, is one for which experimental times of hours may be necessary.

Experiments of this kind promise to provide observations that are directly useful. As important, the theorist can represent these experiments more completely and simply than is the case for (1-g) experimentation. It is expected that successful theoretical representations that need not entertain free convection (for zero-g experiments) are then extensible to $0 \leq g \leq 1$ conditions, in accordance with observations.

References:

1. Anderson, H. E. and Rothermel, R. C. "Influence of Moisture and Wind Upon the Characteristics of Free burning Fires". X Symposium (International) on Combustion, p. 1009. The Combustion Institute (1965).
2. Berlad, A. L., Rothermel, R. C. and Frandsen, W. "The Structure of Some Quasi-Steady Fire Spread Waves". XIII Symposium (International) on Combustion, p. 927. The Combustion Institute (1971).
3. de Ris, J. "Spread of a Laminar Diffusion Flame". XIII Symposium (International) on Combustion, p. 241. The Combustion Institute (1969).
4. Campbell, A. S. "Some Burning Characteristics of Filter Paper". Combustion Science and Technology 3, 103 (1971).
5. Sibulkin, M. "Estimates of the Effect of Flame Size on Radiation From Fires". Combustion Science and Technology 7, 141 (1973).
6. Berlad, A. L. and Krishna, C. R. "Transport Mechanisms In Fire Spread and Extinction". Paper presented at the May 1974 Clay Preston Butler Meeting. Stanford Research Institute (In Press).
7. Hirano, T., Noreikis, S. E., and Waterman, T. E. "Postulations of Flame Spread Mechanisms". Combustion and Flame 22, 353 (1974).
8. Parker, W. J. "Flame Spread Model for Cellulosic Materials". J. Fire Flammability 3, 254 (1972).
9. Waterman, T. E. "Determination of Fire Conditions Supporting Room Flashover". Final Report on IITRI Project M6131 (Sept. 1966).
10. Vogel, M. and Williams, F. A. "Flame Propagation Along Matchstick Arrays". Combustion Science and Technology 1, 429 (1970).
11. De Ris, J., Kanury, A. M., and Yuen, M. C. "Pressure Modeling of Fires". XIV Symposium (International) on Combustion, p. 1133 (The Combustion Institute) 1973.
12. Markstein, G. H. and De Ris, J. "Upward Fire Spread Over Textiles". XIV Symposium (International) on Combustion. p. 1085 (1973).

13. Adams, J. S., Williams, D. W. and Tregellas-Williams, J. "Air Velocity, Temperature, and Radiant-Heat Measurements Within and Around a Large Free-Burning Fire". XIV Symposium (International) on Combustion, p. 1045 (1973).
14. Pagni, P. J. and Peterson, T. G. "Flame Spread Through Porous Fuels". XIV Symposium (International) on Combustion, p. 1099 (1973).
15. Williams, G. C. "Measurement of Flammability and Burn Potential Fabrics". Combustion Institute European Symposium. p. 3 (1973). Academic Press.
16. Abbott, C. "Correlation of Oxygen Index and Other Tests". Combustion Institute European Symposium. p. 165 (1973). Academic Press.
17. Taylor, G. I. "Fire Under Influence of Natural Convection". National Academy of Sciences, Symposium (International) On The Use of Models in Fire Research". Publication 786 (1961).
18. Emmons, H. W., and Shen, T. "Fire Spread in Paper Arrays". XIII Symposium (International) on Combustion. p. 917 (1971).
19. Kinbara, T., Endo, H., and Segal, S. "Downward Propagation of Smoldering Combustion Through Solid Materials". XI Symposium (International) on Combustion. p. 525 (1967).
20. Martin, S. "Diffusion-Controlled Ignition of Cellulosic Materials By Intense Radiant Energy". X Symposium (International) on Combustion. p. 877 (1965).
21. Blackshear, P. L. and Murty, K. A. "Heat and Mass Transfer To, From And Within Cellulosic Solids Burning In Air". X Symposium (International) on Combustion, p. 911 (1965).
22. Shivadev, V. K. and Emmons, H. W. "Thermal Degradation and Spontaneous Ignition of Paper Sheets in Air by Irradiation". Combustion and Flame 22, 223 (1974).

Respondents Comments:

Comments from Professor Robert F. Sawyer
University of California, Berkeley

"....There are some interesting experiments which might make use of the unique space environment. The most obvious are those which involve scaling problems arising from gravitation.. effects. The handling of buoyancy in fire research is perhaps the most direct example."

* * * * *

Comments from Professor P.C. Corlett
University of Washington, Seattle

"The problem I have in mind is the manner in which free-burning fires approach effectively gravity-free conditions in the limit as diameter or other fuelbed length scale approaches zero. This is the small Grashof number limit. In principle, burning rates of low boiling (or low-subliming) fuels should vary inversely with length scale in this limit, a standard result of corresponding droplet burning theory. However, it appears that in most standard atmosphere laboratory situations, other characteristic lengths (derived from finite rate kinetics or real-world apparatus fabrication constraints) enter into the problem in a difficult to resolve manner.A controlled series of small fire experiments in which the Grashof number was varied independently by adjustment of the ambient gravity level would greatly help to clarify the situation" (Ref. R.C. Corlett, Combustion and Flame 12, 1 (1968),. Also see P.L. Blackshear, Jr. and K.A. Murty, Eleventh Symposium (International) on Combustion, p.545)).

IV. 4. Large Surface Solid-Gas Unpremixed Combustion

by G. H. Markstein

Discussion:

Previous fundamental studies of surface combustion of large solid fuel elements have been heavily motivated by the need to understand the nature of unwanted fire. Free convective effects are so significant in the burning of large solids (at $g=1$) that one may question the utility of combustion studies in which (for, $0 \ll g \ll 1$) free convection is strongly suppressed. The considerations provided in the previous subsection (IV.3.) for porous solid arrays generally apply here. As before, the present limited understanding of the interactions of various transport processes, the criticality conditions of combustion phenomena and the lack of "complete" theoretical formulations argue for this range of supportive experimentation. Of course, combustion experiments in space are indispensable to an understanding of fire phenomena in spacecraft. But the broad value of reduced gravitational field combustion studies lies in their relation to the ultimate aim of providing a basic understanding not otherwise accessible.

Drop tower studies (1,2) have provided valuable, gravity-free combustion information on flame spread over solid fuels. However, testing times provided by such facilities are very limited (less than 10 seconds).

In sharp contrast to the absence of natural convection in the gravity-free conditions present in spacecraft, terrestrial burning of large solids is strongly influenced by buoyancy-induced convection. One of the most instructive demonstrations of the dominant influence of buoyancy is provided by the success of pressure modeling of fires (3), which depends on the fact that among the many participating dimensionless parameters, only the Grashof number,

$$Gr = (\Delta\rho/\rho)(gl^3\rho^2/\mu^2)$$

and the Reynolds number,

$$Re = \rho V l / \mu$$

were required to represent the experimental results given in reference (3). Here $(\Delta\rho)$ is the density change over the characteristic dimension (l) ; (ρ) is density; (g) is the gravitational acceleration; (μ) is the viscosity and (V) is the velocity.

The rationale for reduced g-studies lies in the incomplete state of current understanding of flame spread over solid-fuel surfaces. Thus, analyses that are mathematically exact (4) thus far can deal only with laminar spread with prescribed convective flow parallel to the fuel surface. Such analyses therefore do not even describe terrestrial flame spread, and the limits of their validity could be tested more rigorously in the gravity-free space environment. Moreover, in the practically most interesting case of turbulent upward fire spread, natural convection strongly controls the feedback of heat from the gas-phase flame to the fuel, frequently

causing the process to become of a transient accelerating nature, both in the cases of thermally thin (5) and thick fuel (6). These cases have thus far been treated only by semiempirical analyses (5,6). Experiments under gravity-free space conditions could replace the closed-loop accelerating feedback process by a steady-state open-loop flame spread with forced convective flow under the control of the experimenter.

Even in the case of convective flow parallel to the fuel surface (i.e. vertical upward or downward spread) forced convective flow can never model the conditions of natural convection exactly. Even less satisfactory would be any attempts to model the cases of gravity acceleration oriented normal to the fuel surface ("pool-burning" and ceiling fires, respectively), or intermediate orientations of the fuel bed (7,8), by means of forced convection in a gravity-free environment.

Conclusions:

In summary, one must conclude that experiments in space can make a contribution to the understanding of the burning of large solids, primarily by permitting systematic verification and enlargement of analyses of flame spread.

There is a considerable number of experiments of potential interest. Among them are the following:

- 1) Determination of steady flame spread rate over a solid-fuel surface as a function of steady convective flow velocity, both for flow in the direction and opposite to the direction of flame spread.

2) Study of transients of flame spread rate that may occur upon a sudden change of convective flow. Of particular interest would be the case of sudden shutdown of the flow, which may cause extinction after a characteristic relaxation time, due to accumulation of combustion products and lack of oxygen access to the fuel. Conversely, if the flow is re-established after a shutdown of limited duration, a re-ignition transient might occur. (These cases have obvious significance for fire in spacecraft). The alternative possibility of studying such acceleration effects directly, rather than by simulating them with forced convection, is discussed in Section 9. Obviously, a great variety of fuel materials and sample geometry may be of interest. The choice presumably will be influenced partly by suitable burning characteristics and simplicity of geometry, but should primarily be dictated by the theoretical objectives of the experimentation. Both thermally thick and thermally thin fuel samples will be of interest.

In addition to flame spread measurements, determinations of mass burning rates are desirable. In contrast to terrestrial conditions, the continuous measurement of mass loss poses a fairly difficult problem in a gravity-free environment. Instrumentation to meet such needs is discussed in Section V.

References:

1. Andracchio, C.R. and Aydelott, J.C., Comparison of Flame Spreading Over Thin Flat Surfaces in Normal Gravity and Weightlessness in an Oxygen Environment. NASA TM X-1992, May 1970.
2. Cochran, T.M., Petrash, D.A., Andracchio, C.R. and Sotos, R.G., Burning of Teflon-Insulated Wires in Supercritical Oxygen at Normal and Zero Gravities. NASA TM X-2174, Feb. 1971.
3. deRis, J., Murty Kanury, A., and Yuen, M.C., Pressure Modeling of Fires. Fourteenth Symposium (International) on Combustion. p.1033. The Combustion Institute, 1973.
4. deRis, J., The Spread of Laminar Diffusion Flame. Twelfth Symposium (International) on Combustion. p. 241. The Combustion Institute, 1969.
5. Markstein, G.H., and deRis, J., Upward Fire Spread over Textiles. Fourteenth Symposium (International) on Combustion, p.i085. The Combustion Institute, 1973.
6. deRis, J., Orloff, L. and Markstein, G.H., Upward Turbulent Fire Spread and Burning of Fuel Surfaces. Fifteenth Symposium (International) on Combustion (in press).
7. Hirano, T., Noreikis, S.E. and Waterman, T.E. Postulations of Flame Spread Mechanisms. Combustion and Flame 22, 353 (1974); Hirano, T. and Sato, Effects of Radiation and Convection on Gas Velocity and Temperature Profiles of Flames Spreading over Paper. Fifteenth Symposium (International) on Combustion (in press).
8. deRis, J. and Orloff, L. The Role of Buoyancy Radiation and Radiation on Turbulent Diffusion Flames on Surfaces. Fifteenth Symposium (International) on Combustion (in press).
9. Emmons, H.W., private communication.

IV. 5. Droplet Spray and Particle Cloud Combustion

by C. H. Yang

Discussion:

The suspension of combustible fine liquid droplets and solid particles in a gaseous atmosphere may result in sudden explosion under suitable conditions. In order to prevent these catastrophes from happening in industrial plants and coal mines understanding of the combustion process in these media is necessary and essential. In many home heating units, industrial power generating engines, airplane jet engines and rockets, chemical energy is released through flames propagating through fuel droplet sprays. Knowledge of the combustion process is needed to achieve proper designs that have stable operation and high efficiency. Current understanding, however, is far from complete. Burning velocities of these flames are not adequately predicted. Many of the observed characteristics such as the dramatic variation of the lower fuel concentration limit with fuel droplet size, the strong dependence of the suppression of flameability by inerting on particle size, and the surprisingly high burning velocity measured (1) for flames propagating through droplets are not yet explained. Examining the current theories of flames in droplet sprays or particle clouds, a one-dimensional monodisperse model is universally adopted. The work of Williams (2) deals mainly with fuel droplet sprays in an oxidizing atmosphere. He proposed a "quasi-homogeneous" theory which

considers the combustion and heat evolution to take place over the gas volume homogeneously after fuel is evaporized from droplets and mixed with the oxidizer. The mode of combustion is quite similar to that of premixed gaseous flames. For very fine droplets of easily vaporized fuel, this is a satisfactory characterization. According to experimental studies of Burgoyne et al. (1,3,4), the observed flame behavior for tetralin sprays with droplet size smaller than 0.01 mm is very close to that of the premixed gases of the same fuel and oxidant. It follows, then, that the aforementioned theory is not expected to apply for droplets that exceed this size limitation. Recently, Yoshie and Oshima (5) and Vainshtein and Nigmatulin (6) proposed more general theories for flames propagating in a two-phase medium. These more recent theories are intended to be applicable to all three limiting modes observed in experiments: The "quasi-homogeneous" flame in very fine droplet sprays, the flame with pure heterogeneous combustion on the surface of the condensed phase in particle clouds and the flame with thin shell reaction zone surrounding each fuel drop in sprays of medium and large droplet sizes. Ignition of the unburned droplets or particles (in the latter theories) is induced by the temperature rise in the gaseous phase with heat conducted from the immediate flame zone. This propagation mechanism, however, is not completely consistent with experimental observation. Burgoyne and Cohen (1) pointed out that for a tetralin spray with droplet sizes greater than 0.053 mm a burning drop may directly ignite its adjacent neighbor with its own flame shell while the average temperature of the gas between the droplets remains relatively low. The propagation of the flame front appears to be irregular.

Migutain and Ogasawara (7) also obtained direct photographs to show that each droplet is surrounded by an individual flame zone with no apparent combustion taking place in the interdroplet space. Yoshie and Oshima (5) and Vainshtein and Nigmatulin's (6) theories must be tested against experimental measurements. Unfortunately, for droplet or particle sizes greater than 0.02 mm, and at $g=1$, downward flame propagation in a vertical tube or horizontal flame propagation in a level tube cannot be obtained on account of settling of the condensed phase. Current data are generally measured with flames propagating upward in a vertical tube. The relative velocity between the droplets (or particles) and surrounding gases in such a case complicates the flame mechanism so severely that a reasonably simple one-dimensional model no longer appears to be suitable.

Migutain and Ogasawara (7) took a novel approach and formulated a theory for upward propagating flames. Their efforts are not particularly successful as many of the experimental observations are still unexplained. It appears that a flame theory along the lines of Yoshie and Oshima (5) or Vainshtein and Nigmatulin (6) must be constructed without the complications of particle settling effects. After its validity is successfully established by experimental measurements (which can be performed in a zero-g environment) it may then be modified for upward propagating flames. The zero-g measurements, no doubt, will also be very useful in guiding the initial phase of the theoretical development. The shuttle program of NASA offers a unique opportunity for such a study which may potentially benefit public safety from disasters and stimulate technical advances in industry.

Conclusions:

Fuel and Oxidant Material

The study should be made with monodisperse sprays and clouds with droplet and particle sizes ranging from 0.01 to 0.50 μ m. Monodisperse sprays with droplets of a desired size may be separated from a jet stream of a fuel atomizer with an elutriation tunnel. Burgoyne and Cohen's (1) technique of preparing monodisperse spray through condensation of super-saturated fuel vapor is probably more precise but the apparatus required may be cumbersome for the space laboratory. Monodisperse solid particles may be prepared beforehand and brought to the shuttle laboratory.

Tetralin, metal powders, and coal dust (8) should be among the first to be considered as the fuel material as they have been commonly used in the past. Air and pure oxygen may be used as oxidants and nitrogen is a convenient choice for inert dilution.

Experiments

Flame flash back in monodisperse droplet spray and particle cloud in tubes of about 5 cm diameter and 1 meter long are adequate for the study. Measurements should include burning velocity, flame structure, lower fuel concentration limit and inert dilution limits. Clouds of drops and particles and combustion systems mentioned in previous discussions (e.g. Section IV.2.) are of particular interest.

References:

1. Burgoyne, J. H. and Cohen, L. Proc. Roy. Soc., 1954, A225, 375.
2. Williams, F. A., Combustion and Flame, 1959, 2, 215.
3. Burgoyne, J. H., Newitt, D. N. and Thomas, A. Engineer Loud., 1954, 195, 165.
4. Burgoyne, J. H. "The Flammability of Mists and Sprays" Second Symposium on Chemical Process Hazards, Inst. Chem. Engrs., 1963.
5. Yoshie, T. and Oshima, N. Astronautica Acta, 1972, 17, 729.
6. Vainshtein, P. B. and Nigmatulin, Zhurnal Prikladnoi Mekhaniki: Tekhnicheskoi Figiki, 1971, 4, 19.
7. Migutain, Y. and Ogasawara, M. Int. J. Heat and Mass Trans., 1965, 6, 921.
8. Nagy, J., Dorsett, H. G. and Jacobson, M. "Preventing Ignition of Dust Dispersions by Inerting" BuMines Dept Inv. 6543, 1964.

Respondents Comments:

The following comments were received from Professor P. S. Myers (University of Wisconsin):

"One of the criteria for judging of experiments is that the experiment when conducted in space would yield results unobtainable with gravity. Within this criterion, I would give first priority to those experiments yielding information having the most extensive application."

"I would put single droplet combustion, especially at high pressures, in this high priority classification. Theoretical analysis of droplet vaporization near the critical point is complicated by uncertainty regarding

absorption of the ambient gas in the vaporizing liquid, and uncertainty of drop shape due to diminution or disappearance of surface tension. When gravity is present, there is inevitably flow past the drop which, at low surface tension, distorts the drop. In a zero gravity field the vaporization of a single drop without convection could be observed. The equations of change can be solved numerically for this situation so theoretical results could be directly compared with experimental results. The vaporization of liquid fuels at both low and high pressures is of considerable practical importance so the results would be of immediate interest. I would put this experiment well towards the top of the list on both counts."

"I would also put burning single particle (coal, for example) experiments well at the top of the list for the same reasons. I would include array studies once the single droplet studies were completed. A second series of experiments I think ought to receive serious consideration is the effect of convection on the spread of fires on solid or liquid surfaces. A zero gravity field would enable the problem to be studied without convection while increasing of gravity could increase convection to separate out different effects. Again, understanding the spread of flames on solid and liquid surfaces is of considerable practical importance."

Turbulent two phase combustion processes have not been discussed here, but important effects have been noted by several respondents.

From Professor E. E. O'Brien

State University of New York at Stony Brook

The motion of a particle in a turbulent fluid can be described with reasonable generality by an equation of the type (1)

$$T\ddot{x}_i + \dot{x}_i = u_i(x_j, t) + Tg\delta_{i3}, \quad (1)$$

where T is a particle characteristic time carrying the inertial property of the particle [for example

$$T = \frac{D^2}{36\nu} \left(\frac{2\rho_p}{\rho} + 1 \right)$$

for a solid spherical particle where D is its diameter, ν is the fluid viscosity, ρ the fluid density and ρ_p the particle density],

x_i is the particle displacement vector,

u_i is the fluid velocity,

g the acceleration due to gravity, and

the dot indicates a time derivative.

There are two parameters in (1), T and g. In the event that both are negligible $\dot{x}_i = u_i(x_j, t)$ and the particle simply follows the fluid trajectories in a passive way.

More commonly of course neither T nor Tg, the drift velocity, are negligible. Earth-bound turbulence experiments on particle trajectories (2) run into two complicating effects which cannot be decoupled. Namely, an inertial effect due to the first term in equation (1), and a "crossing trajectories" effect due to the drift velocity Tg in the last term in (1).

It has long been established (3) that the crucial quantity determining particle transport properties in turbulence is the particle autocorrelation function, which has to be determined experimentally (2). Some discrepancies (2,4) have appeared in these experiments with regard to the roles the two effects mentioned above play in determining the autocorrelation function. A space vehicle experiment utilizing zero g and variable g capabilities could serve to distinguish between the two parameters T and Tg and allow a clear cut understanding of their role in turbulent diffusion of condensed phase particles. The applicability to combustion is of course indirect. For those problems in which particle migration is important one must be able to determine where a particle, or cloud of particles, will be before inserting the chemical parameters which vary locally. It is also a problem of very general importance for transport processes in turbulent fluids. Experimental attempts to obtain truly passive particles in earth-bound experiments seem not to be fruitful (2).

References:

1. Lumley, J. L. "Some Problems Connected with the Motion of Small Particles in a Turbulent Fluid", Ph.D. Dissertation, Johns Hopkins University, 1957.
2. Lumley, J. L. and W. H. Snyder, J.F.M. 48, 41 (1971).
3. Taylor, G. I., "Diffusion by Continuous Movements", Proc. London Math. Soc. A, XX, 196-212 (1921).
4. Kennedy, D. A. "Some Measurements of the Dispersion of Spheres in a Turbulent Flow", Ph.D. Thesis, Johns Hopkins University, 1965.

Also, see comments by Professor J. M. Beer, given in Section IV.2.

IV. 6. Source Ignition and Autoignition in Premixed
Gases and Condensed Fuel Sprays

by C. H. Yang

Discussion:

When a source of energy is introduced into a fuel-oxidant mixture, ignition may occur. The successful ignition often depends on the quantity of energy introduced by the source. For a specific system, there exists a minimum ignition energy below which the source will fail to provide successful ignition. The size of the minimum ignition energy, on the other hand, depends on the composition and state of the mixture, the geometry of the container and energy distribution of the source. When critical conditions are approached, the minimum ignition energy may become zero. The system autoignites or explodes under such circumstances. The state of the mixture is referred to as explosion limits of the system. Both the source ignition and autoignition phenomena have been extensively studied (1-17) in the past. Feasible theories have been constructed to explain the general physical mechanism of the ignition phenomenon. Only the detailed kinetics for many of the combustible systems remain unclear and many of the numerical values of the rate constants involved are still uncertain. Carefully measured explosion limits often are essential for furnishing this type of kinetic knowledge.

The comprehensive study by Gray et al. (8-12) on thermal explosions, indicates that the effects of the convection process due to buoyant forces generated from differential heating are significant especially when the

density of the mixture is high. To avoid these uncertainties, experiments are ideally performed in a zero-g environment. The Space laboratory of the NASA shuttle program offers a unique opportunity for this type of experimentation.

Currently, measurements of minimum ignition energy and explosion limits for condensed fuel sprays are almost non-existent. The sedimentation of the condensed phase prevents a meaningful experiment from being performed in ordinary experimental conditions. Again, these difficulties may be easily avoided in a zero-g environment. Information obtained will definitely aid the understanding of flame propagation in fuel droplet spray or particle cloud discussed in the previous section.

Conclusions:

Source Ignition Experiment

Source ignition experiments may be considered for both premixed gases and condensed fuel sprays. There are many premixed gaseous systems to choose from. For condensed fuel sprays, coal dusts and tetralin droplets proposed in the previous section again deserve consideration. Three types of ignition sources may be used: spark, hot wire and hot gas (or hot solid body). These sources are expected to provide a wide range of energy distribution.

Autoignition or Explosion Experiment

For premixed gases, only thermally explosive systems should be selected. Gray et al. (11) used chlorine dioxide, methyl nitrate and diethyl peroxide. Thermal effects for the H_2-O_2 and $CO-O_2$ system also become important at high pressures. The most interesting explosion experiment is probably with fuel droplet spray and particle cloud. Tetralin droplets and coal dusts are among suitable choices of condensed fuels.

References:

1. Lewis, B. and von Elbe, G. "Combustion Flames and Explosions of Gases" Academic Press, 1961.
2. Voevodsky, V. V., Seventh Symp. (International) on Combustion Butterworth, London, 1958, 34.
3. Yang, C. H., Combustion and Flame, 6, 1962, 215.
4. Rosen, G., J. Chem. Phys. 30, 1959, 298.
5. Stout, H. P. and Jones, E. Third Symposium (International) on Combustion, Williams and Wilkins: Baltimore, 1949, 329.
6. Semenov, N. N. "Chemical Kinetics and Chain Reactions" Oxford Univ. Press, London, 1935.
7. Semenov, N. N. "Some Problems in Chemical Kinetics and Reactivity" Vol. I & II, Princeton Univ. Press, Princeton, N.J., 1959.
8. Fine, D. H., Gray, P. and MacKinven, R., Proc. Roy. Soc. Lond. A 316, 1970, 223.
9. Fine, D. H., Gray, P. and MacKinven, R., Proc. Roy. Soc. Lond. A 316, 1970, 241.
10. Fine, D. H., Gray, P. and MacKinven, R., Proc. Roy. Soc. Lond. A 316, 1970, 255.
11. Gray, P., Jones, D. T. and MacKinven, R., Proc. Roy. Soc. Lond. A 325, 1971, 175.
12. Gray, P., Lee, P. R. and MacDonald, Combustion and Flame 13, 1969, 461.
13. Gray, B. F. and Yang, C. H., J. Phys. Chem. 69, 1965, 2747.
14. Yang, C. H. and Gray, B. F., 11th Symp. (International) on Combustion, The Combustion Institute, Pittsburgh, Pa., 1967, 1099.
15. Foo, K. K. and Yang, C. H., Combustion and Flame 17, 1971, 223.
16. Baldwin, R. R., Jackson, D., Walker, K. W. and Webster, S. J., Trans. Faraday Soc. 63, 1967, 1665, 1676.
17. Yang, C. H. "Oscillatory and Explosive Oxidation of CO" to be published.

IV. 7. Premixed Gaseous Flame Propagation and Extinction Limits

by A. L. Berlad

Discussion:

Once successful ignition of a premixed combustible gas is achieved, a broad range of time-varying flame propagation phenomena is possible. However, where apparently steady (quasi-steady) flame propagation results, the phenomenological possibilities are few. The unperturbed quasi-steady flame, whatever its invariant multidimensional temperature and composition structure, propagates at a fixed flame speed. Generally, quasi-steady flames are observed as multidimensional flames propagating in long tubes, or as "flat" or "conical" flames stabilized on the lips of tubular burners. For a given size, shape, and temperature of experimental apparatus, there exist limits of ambient temperature, pressure, fuel-oxidant ratio, and diluent concentration beyond which quasi-steady flame propagation is not possible. Beyond these extinction conditions, quasi-steady flames cannot be established on burners or caused to propagate through long tubes. Further, the size, shape and temperature of the experimental apparatus influence the extinction condition. Special names have come into use for special extinction conditions. Flammability limits generally refer to the critical values of fuel lean (or fuel rich) composition, which, for a 5 cm. i.d. tube and a pressure of 1 atm., correspond to quasi-steady flame extinction. Quenching limits generally refer to the critical values of apparatus size which correspond to flame extinction. Pressure

limits refer to critical lower (or upper) values of ambient pressure which correspond to flame extinction, having fixed the other experimental parameters. It is now known that these various experimentally determined extinction limits are not unrelated. Figure 1. (references 8,20) shows that pressure, quenching and flammability limits represent special cases of a multidimensional extinction limit diagram defined by the thermochemical and physical parameters of the problem.

A number of theories attempt to interpret observations on flame propagation and extinction. Details and emphases vary, but central agreement exists regarding the nature of extinction limits. Quasi-steady flame propagation is nonadiabatic, and losses of heat (and reactive species) from flame to (finite-sized) apparatus necessarily results. It is these losses which necessarily limit quasi-steady flame propagation and prescribe extinction limits.

The terse summary statements, provided above, derive directly from the information given in the references.

There are several propagation modes for nonadiabatic flames. There are several transport mechanisms through which a given mode of propagation sustains the losses which affect the extinction conditions. Gravitational effects enter both as a mechanism important to flame structure and as a loss mechanism. Accordingly, flame propagation and extinction can be substantially influenced by free convective effects. Striking examples of the effects of gravity on flame propagation and extinction include:

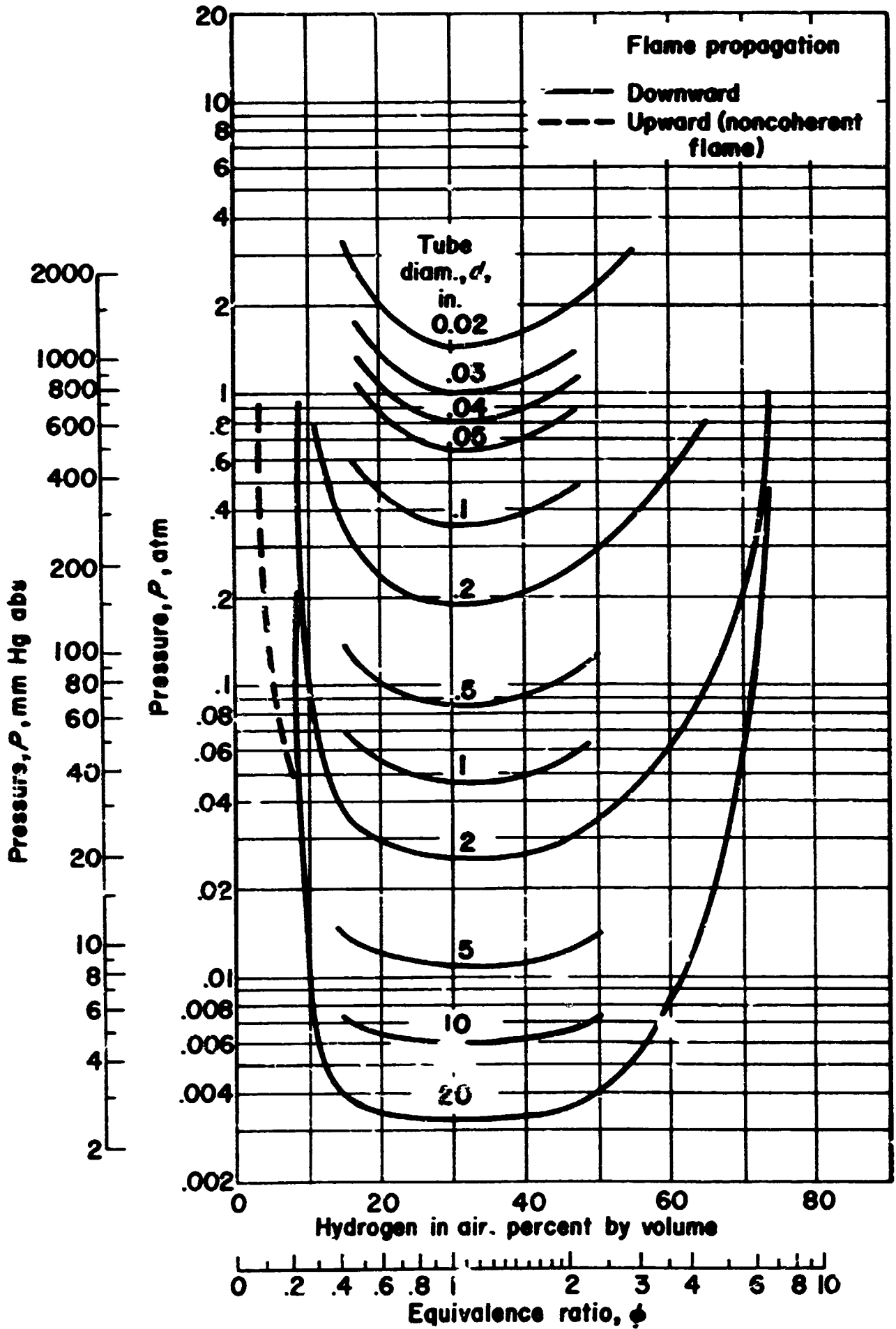

Figure IV.7.1. Estimated pressure limits of flame propagation for hydrogen-air mixtures with various tube diameters. Based on extrapolation of quenching data of references 8, 20.

- (1) Upward flame propagation (in tubes) is characterized by a different flame structure, speed, and lean extinction limits than those obtained for downward propagation, at $g=1$.
- (2) Where a propagating flame appears to have a simply-connected surface, it is termed "coherent". Flame propagation may proceed via "coherent" or "noncoherent" modes. Both modes of propagation, and their associated lean extinction limits are significantly influenced by free convective effects. In fact, for the case of hydrogen-air flames, reference (8) provides the following summary of data, at $g=1$.

	Flammability Limits, volume percent hydrogen in air	
	LEAN	RICH
Upward Propagation		
Coherent Flame	9.0	74
Noncoherent Flame	4.0	
Downward Propagation	9.0	74

There appears to be an important coupling of selective diffusion, flame front stability, and free convection effects in the neighborhood of the noncoherent flammability limit (4.0 percent H_2). Because of the

much higher molecular diffusivity of H_2 , compared to that of O_2 , a noncoherent flame volume has its H_2 concentration enriched by diffusion. Based on the initial stoichiometry of the mixture, the (free convectively) rising noncoherent flame volume burns at a richer fuel concentration, leaving incompletely burned gases behind.

- (3) As the characteristic size of apparatus is increased, convectively induced "noncoherent flames" (above) as well as "flame balls" (ref. 4) are observed. Lovachev and coworkers (ref. 19) consider a simplified theory of "convective flammability limits" wherein the limiting fundamental flame speed depends upon the acceleration due to gravity.

$$(U_c)_{lim} = 2 \left[\frac{2}{3} \frac{\lambda_m}{c/c_p \rho_m} \left(1 - \frac{\rho_b}{\rho_0}\right) \left(\frac{\rho_b}{\rho_0}\right) \frac{g}{c_w} \right]^{1/3}$$

Here, λ_m is the thermal conductivity, c the heat capacity, ρ_0 the initial density, ρ_b the hot gas density, c_w is a viscous coefficient, ρ_m a heat release coefficient, and g the acceleration due to gravity. Elements of a Grashof number correlation are recognizable in the expression for $(U_c)_{lim}$. But only $g=1$ data are now available.

- (4) Complicated flame shapes, convectively related, have been observed (particularly near extinction limit conditions) for hydrogen-air, methane-air, carbon monoxide-air, heavier hydrocarbon-air, etc. for a range of apparatus sizes and shapes, at $g=1$.

- (5) In some of the cases cited above, quasi-steady flame propagation is associated with significantly incomplete combustion of the initial reactants.

This consequence is examined in reference (22) and is related to the noncoherent phenomena that Lovachev (3) has reviewed. Reference (22) provides a different representation, based on flame front stability arguments, from that given in reference (3).

- (6) Despite the clear multidimensionality of propagating (or near extinction) flames, current "complete" theories of flame propagation and extinction are one-dimensional and ignore gravitational effects. Table (1) shows that only a few simplified theories (those not starting with the general conservation equations) attempt to include free convective effects.

Conclusions:

The major role played by gravitational effects in many flame propagation and extinction phenomena--and the lack of adequate theory to deal with these complex flame systems--suggests the need for a systematic investigation along the following lines:

- (1) Experimental determinations (at $g=0$) of gravity independent flame propagation and extinction phenomena, including flame structures, propagating speeds, propagating modes and the full range of extinction limits. Particularly important are the previously-cited combustion systems.
- (2) Experimental determinations, as indicated above, repeated over the range $0 \ll g \ll 1$, thereby determining the onset and manner whereby free convection effects enter these phenomena.

References	Losses		Dimensionality Considered			Transport Properties Considered			
	Nonadiabatic	Multi-dimensional	1-Dimensional or others	1-Dimensionalized	Free Convection	Radiation	Molecular Conduction of Heat & Mass		
Hirschfelder & Curtiss, C. F. (26)	-	-	X	-	-	-	X		
Spalding, D. B. (33)	X	-	-	X	-	-	X		
Berlad, A. L. & Yang, C. H. (38)	X	-	-	X	-	X	X		
Lewy, A. (34)	-	-	X	-	X	-	-		
Lovachev, L. A. (39)	-	-	X	-	X	-	-		

- Consideration absent in theory.

X Consideration provided in theory.

Table IV.7.1

Premixed Gaseous Flames: Quasi-Steady Flame Propagation and Extinction Limit Analyses

- (3) Experimental determinations, as indicated above, repeated for $g > 1$.
- (4) A theoretical program aimed at developing "complete" theories of flame propagation and extinction that are adequately representative of the complex phenomena observed. Table I summarizes the current, notably deficient, state of affairs.

It is clear that the time scales for the initiation, development and observation of the propagation and extinction phenomena may vary widely. In some cases, drop tower studies may prove extremely useful. In a large number of cases (slowly developing phenomena in large apparatuses), experimentation in and with a space orbiting laboratory appears to offer the only approach for definitive study.

References:

1. Lewis, B. and Von Elbe, G., "Combustion, Flames and Explosions of Gases". Academic Press (1961).
2. Coward, H. F., and Jones, G. W. "Limits on Flammability of Gases and Vapors". Bulletin 503, U. S. Bur. of Mines (1952).
3. Lovachev, L. A., et al. "Flammability Limits: An Invited Review". Combustion and Flame 20, 259 (1973).
4. Strehlow, R. A. "Fundamentals of Combustion". International Textbook Company (1968).
5. NACA Report 1300 (1957).
6. Hirschfelder, J. O., Curtis, C. F. and Bird, R. B. "The Molecular Theory of Gases and Liquids". John Wiley and Sons, New York (1954).

7. Spalding, D. B. "Some Fundamentals of Combustion". Academic Press (1955).
8. Drell, I. L. and Belles, F. E. "Survey of Hydrogen Combustion Properties". NACA Report 1383 (1958).
9. Lewis, George D. "Centrifugal-Force Effects on Combustion". XIV Symposium (International) on Combustion. p. 413 (1973).
10. Andrews, G. E. and Bradley, D. "Limits of Flammability and Natural Convection For Methane-Air Mixtures". XIV Symposium (International) on Combustion. p. 1119 (1973).
11. Halstead, M. P., Pye, D. B., and Quinn, C. P. "Laminar Burning Velocities and Weak Flammability Limits Under Engine-Like Conditions". Combustion and Flame 22, 89 (1974).
12. Ryason, P. R. and Hirsch, E. "Coal Flame Quench Distances". Combustion and Flame 22, 131 (1974).
13. Spalding, D. B. Proc. Roy. Soc. A240, 83 (1957).
14. Levy, A. Proc. Roy Soc. (London) A283, 134 (1965).
15. Furno, A. L., Cook, E. B., Kuchta, J. M., and Burgess, D. C. "Some Observations on Near-Limit Flames". XIII Symposium (International) on Combustion. p. 593 (1971).
16. Andrews, G. E. and Bradley, D. "The Burning Velocity of Methane-Air Mixtures". Combustion and Flame 19, 275 (1972).
17. Yang, C. H. "Burning Velocity and the Structure of Flames Near Extinction Limits". Combustion and Flame 5, 163 (1961).
18. Berlad, A. L. and Yang, C. H. "A Theory of Flame Extinction Limits". Combustion and Flame 4, 325 (1960).
19. Lovachev, L. A., Dokl. Akad. Nank SSSR 193, 634 (1970).
20. Potter, A. E. Jr. and Berlad, A. L. "The Effect of Fuel Type and Pressure on Flame Quenching". Sixth Symposium (International) on Combustion. Reinhold Pub. Corp. p. 27 (1957)
21. Williams, F. A. "Combustion Theory" Addison-Wesley (1965).
22. Markstein, G. H. "Nonsteady Flame Propagation" (ACARDograph No. 75) pp. 9-12. Pergamon Press, 1964.
23. Coward, H. F., and Brinsley, F. J., Chem. Soc. 1, 1859 (1914).

IV. 8. Large Surface Liquid-Gas Unpremixed Combustion

by Clayton Huggett

Discussion:

Combustion at liquid surfaces has been studied extensively in the terrestrial environment. Detailed phenomenological descriptions of the various stages of the process, ignition (1,2,3), flame spread (4,5), steady burning (6,7), and extinguishment, are available and a considerable degree of theoretical understanding has been achieved. Limitations on observation time and the size and complexity of apparatus has prevented the extension of these studies to conditions of zero gravity except for limited observations of the burning of small liquid droplets (see Sect. IV.2).

The problem of burning at a liquid surface is, in some respects, simpler than that of combustion at solid surfaces since large area, undisturbed, liquid surfaces will assume a planar configuration normal to the direction of the gravitational field. Experimental representations of this arrangement are referred to as pool fires or pan fires. Changes in orientation or geometry do not enter into the picture. The process of volatilization of a liquid is also simpler and more amenable to quantitative description than the pyrolysis of a solid. Mobility within the liquid phase does provide a complication which is absent in solid combustion.

In the absence of a gravitational field the situation is quite different. A solid fuel (or a confined gas) will retain the same shape that it occupies on earth. An unconfined liquid, on the other hand, in the absence of hydrostatic forces due to gravity, will assume a spherical

configuration due to surface tension. In contact with a solid surface that is wetted by the liquid, the surface configuration will be determined by the contact angle and surface tension forces. Thus in a "pan" whose walls are wetted, the liquid surface will assume a concave hemispherical configuration. To observe surface burning phenomena under conditions approximating a plane surface (radius of curvature large with respect to thickness of the reaction zone) large scale experiments may be required.

Large scale experiments may also be desirable to avoid edge effects. In the case of flame spread, a tray width of about 20 cm is necessary before such effects become negligible (8). In the case of steady state burning the burning rate decreases with increased pool diameter in the small diameter laminar flow region, increases through a transition region, and then levels off - pool diameters greater than about 100 cm where the flame is fully turbulent and radiant energy transfer plays a dominant role (6). Such large scale experiments will present obvious problems in the environment of the space shuttle.

Several methods of stabilizing a planar surface can be considered. A gelling agent may be used in a gravitational field to prepare a plane surface which would retain its configuration in the absence of gravity. The low concentration of gelling agent required would be expected to have a minor effect on steady state burning, but would seriously affect studies of ignition and flame spread where liquid mobility plays a major role. The use of wicks or porous plates would have similar limitations. Since surface tension forces are relatively weak in many liquids, however, a relatively small acceleration force would cause the liquid surface to

assume a nearly planar configuration in a pan oriented normal to the acceleration vector. The use of near-zero gravitational conditions will have other attractive features in the study of combustion processes. The suitability of the space shuttle for this mode of operation should be investigated.

It is convenient to consider the combustion of liquids in two regimes: liquids at temperatures above their flash point, and liquids below their flash point (9). When a liquid surface is in contact with air at a temperature above the flash point, a combustible air-vapor mixture will exist above the liquid surface. Ignition and flame spread, under these conditions, resemble the phenomena which occur in premixed gas combustion discussed in Section IV.7. However, the rate of flame spread over the liquid surface may be as much as five times the maximum flame speed observed in premixed gases (10). This has been attributed to a two-dimensional structure of the advancing flame front with the maximum flame velocity at a distance from the surface corresponding approximately to the formation of a stoichiometric mixture. Since this flame structure has been thought to be independent of buoyancy effects, the measurement of surface flame speeds under conditions of zero gravity could provide an important check on this hypothesis.

For liquids at temperatures below their flash point, energy must be supplied to the surface of the liquid to evaporate sufficient fuel to form a flammable fuel-air mixture before combustion can take place. In the case of ignition, this energy is supplied by an external energy source and the time to ignition is determined by the balance between energy flux to the liquid and energy dissipation within the liquid. The latter is too great

to be accounted for by thermal conductivity, and has been attributed to a cellular flow due to a combination of surface and buoyancy forces (2). Since the surface force will be independent of gravity, ignition experiments at low or zero gravity offer a promise of increased understanding of the ignition phenomenon.

Flame spread over the surface of a liquid at temperatures below the flash point depends on the preheating of the liquid surface ahead of the advancing flame front. The relative importance of the various modes of energy transfer, radiation from the flame, gas phase convection, liquid phase conduction and convection, is still a matter of dispute (5). Glassman and his associates present convincing evidence that surface tension driven flows play an important role in this process (9,11). Buoyancy effects will also play a role. Torrance has carried out a detailed mathematical analysis of these flows and obtained good agreement with experimental observations (12). Again, the study of flame spread over liquid surfaces in the absence of a gravitational field can be expected to provide information which will contribute to the development of better theoretical models and lead to a better understanding of the flame spread phenomenon.

Steady state pool burning of liquids depends on the entrainment of air in the buoyant convective plume to provide the oxygen to react with the fuel vapor (7). It appears that large stable pool fires will not be possible in the absence of an acceleration field to drive the convective plume. If the gravitational field is decreased from its normal value, the Grashof number which controls the convective plume velocity will decrease proportionately. The onset of turbulence will

be delayed, and the transition from laminar to turbulent control of the burning rate can be studied over a range of fire diameters. This should permit a better differentiation between radiative and convective energy transfer to the liquid pool.

Since stable pool fires cannot exist under conditions of zero gravity, the question of extinguishment under these conditions is moot. Extinguishment of fires at low g will involve the intervention of some external agent. Unless carefully applied, this may induce acceleration forces which may enhance the combustion. This will be of practical importance in designing fire extinguishment systems for spacecraft, but it is not apparent that it will increase our understanding of combustion processes.

Conclusions:

The following types of experiments involving large surface liquid-gas unpremixed combustion are suggested for the space shuttle.

The possibilities for conducting experiments in a constant low g acceleration field should be thoroughly evaluated. This mode of operation appears to offer important advantages in studying the role of buoyant convection in a variety of combustion processes.

Measurements of flame spread rates over the surfaces of liquids at temperatures above their flash point should be made to provide information on the structure of the gas phase flame front.

Studies of the ignition of liquids at temperatures below their flash points should be carried out to show the relative importance of buoyancy and surface tension flows.

Studies of flame spread over the surfaces of liquids at temperatures below their flash point should be made to provide an input to the development of better theories of flame spread.

Steady state pool burning should be investigated under conditions of low g to assess the role of buoyant convection in controlling the rate of combustion in pool fires.

References:

1. Burgoyne, J. H., Roberts, A. F. and Quinton, P. G., Proc. Roy. Soc. (London) Series A, 308 39 (1968).
2. Murad, R. J., Lamendola, J., Isoda, H., and Summerfield, M., Combust. Flame 15, 289 (1970).
3. Roberts, A. F., Combust. Flame 17, 440 (1971).
4. Akita, K., Fourteenth Symposium (International) on Combustion, Combustion Institute, Pittsburgh, P 1075 (1973).
5. Sirignano, W. A., Comb. Sci. and Tech., 6 95, (1972).
6. Blinov, V. I. and Khudiakov, G. N., Academia Nauk, SSSR Doklady, 113, 1094 (1957).
Reviewed by: Hottel, H. C., Fire Research Abstracts and Reviews, 1, 41 (1959).
7. Thomas, P. H., Baldwin, R., and Heselden, A. J. M., Tenth Symposium (International) on Combustion, Combustion Institute, Pittsburgh, P 983 (1967).
8. MacKinven, R., Hansel, J. G., and Glassman, I., Comb. Sci. and Tech., 1, 293 (1970).
9. Glassman, I. and Hansel, J. G., Fire Research Abstracts and Reviews 10, 21. (1968).
10. Glassman, I., Comments on Reference 4., p 1081.
11. Sirignano, W. A., and Glassman, I., Comb. Sci. and Tech., 1, 308 (1970).
12. Torrance, K. E., Comb. Sci. and Tech, 3, 133 (1971).

IV. 9. Experiments Performed In A Low- Or
Variable-Acceleration Environment

by G. H. Markstein

Discussion.

Preceding subsections have dealt substantially with combustion experiments performed under gravity-free conditions. The scope of several of these studies can be greatly expanded by using the propulsion system of the Space Shuttle either to maintain a constant low level of acceleration, or to perform experiments during acceleration transients.

While this extension of the work could in principle be applied to any of the combustion experiments discussed earlier, it is undoubtedly of greatest interest in those cases in which the effect of acceleration is dominant. This is the case primarily for unpremixed combustion in the absence, or at low levels, of forced-convection flow. Under these circumstances natural convection may be required for the continuous access of oxygen to the reaction zone and the removal of combustion products from it. In some cases, under zero-g conditions, combustion cannot be maintained indefinitely; in other words, absence of gravity constitutes a singular case.

Consider, as a specific example, an experiment on steady burning of a solid-fuel surface. As discussed in section 4, to maintain steady combustion in a given gravity-free environment, forced convective flow must be provided. If, however, the shuttle's propulsion system is used

to produce a steady low level of acceleration, steady-burning experiments could readily be performed without forced convection. By varying the magnitude of acceleration, a relationship between burning rate and acceleration level could be determined, and the possible existence and magnitude of a lower acceleration limit could be established, below which steady combustion cannot be maintained. Moreover, in addition to experiments during steady acceleration, effects of acceleration transients could be investigated. Of special interest in connection with fire in spacecraft are two cases: 1) sudden removal of acceleration, causing extinction of the fire after a relaxation period, and 2) reignition of a nearly extinguished fire after re-establishment of a finite acceleration level.

As discussed in section 4, effects of both steady and transient acceleration can be simulated to some extent by forced convection. However, the modeling of free convection by forced convection is never exact, and particularly unsatisfactory when the acceleration vector is normal to the fuel surface. Thus, studies involving the use of acceleration rather than forced convection are certainly more realistic. Moreover, since the need for a blower facility is eliminated, the apparatus is considerably simplified and its cost reduced. The need for additional fuel to operate the propulsion system during the experiments would be compensated by eliminating the power requirements of the blower facility. The only conceivable complication offsetting these advantages would be the need for close cooperation between the scientist performing the experiment and an astronaut operating the propulsion system.

While the preceding discussion has singled out the case of steady burning of a solid fuel, in which the advantages of working with low-level or variable acceleration are particularly obvious, similar advantages may accrue in various other combustion studies in the Space Shuttle. Since the use of the existing propulsion system requires no addition to the apparatus, except for the possible addition of an accelerometer, it is recommended that the possibility of this extension of the experiments be considered in the planning of many of the studies discussed in preceding sections.

Since the effect of acceleration is determined by the Grashof number, a change of acceleration in the ratio a/a_0 is equivalent to a change of length scale by $(a/a_0)^{-1/3}$. Thus, the scaling aspects of low-acceleration experiments would be of value for studying details of flame structure at an increased scale (1). On the other hand, a primary interest in fire research is in reducing the length scale, so that accelerations in excess of g would be required. It appears therefore unlikely that this particular application of finite acceleration in combustion experiments in space would offer any advantages over the successful method of pressure scaling (2).

References:

1. Kanury, M. A., Discussion remarks at the Meeting of the Scientific Study Group on Combustion Experiments in Space, Stony Brook, July 27, 1974.
2. de Ris, J., Kanury, M. A., and Yuen, M. C., Pressure Modeling of Fires. Fourteenth Symposium (International) on Combustion, p. 1033. The Combustion Institute, 1973.

IV. 10. Large Chemical Beam Combustion

by F. Kaufman

Discussion:

Combustion processes in pre-mixed gases take place in three partially overlapping stages which may be characterized as follows: In the initiation or pre-heat zone, heat conduction and diffusion of reactive species bring about chemical reactions which are either sufficiently exothermic to produce an exponential temperature rise or produce a net increase of reactive radicals by chain-branching reactions. In the main reaction or flame zone reactants are substantially used up in fast, two-body reactions which do not necessarily lead to the stable combustion products, particularly when recombination steps are required as in the formation of H_2O . Such exothermic recombinations occur relatively slowly in the burnt or post-flame gas at high and rising temperatures.

It is the general idea of this proposed experiment that the nearly infinite pumping capacity afforded by the space environment be used to extend the traditional range of the crossed molecular beam technique (1) in an attempt to study multiple collision events roughly corresponding to flame zone reactions. This may be brought about by an increase of reactant densities in large nozzle beams to a value where the mean free path for reaction is smaller than the linear dimension of the beam intersection volume so that secondary reaction products may be observed. Atoms or radicals generated prior to and during beam production would be used to initiate the reaction chain within the beam intersection volume.

In the experiment, a large supersonic nozzle beam is crossed by a second beam, either a small-to-large nozzle beam or a capillary-array effusive beam, to produce joint density in the interaction region sufficient to result in multiple reactive collisions. One or both of the beams contain reactive radicals. Excited primary, secondary, etc. combustion intermediates are detected by observing their chemiluminescence whereas ground state product species are observed by the use of resonance fluorescence where possible. The beam sources, collimators and detector array are mounted on a scant but rigid framework designed to take maximum advantage of space vacuum.

Production of supersonic nozzle beams of high intensity (2) dates back to the early sixties, but is still an area of active and expanding research. The main criteria for optimum performance are now relatively well established (2b): the important parameters are the nozzle diameter, d , the nozzle-skimmer distance, l , the skimmer aperture diameter, d_s , the exterior and interior skimmer-cone half-angles, α and β respectively, and the skimmer length l_s . Most experimental evidence lends credence to scaling of all linear dimensions with d , which of course, is critical to the design of a large nozzle beam. Separate experiments testing this extension may be necessary. As possible experimental conditions we take $d = 1$ cm, $l/d = 10$ to 100 (adjustable), and pre-expansion pressure $p_0 = 100$ torr at 300°K. The volume flow rate is then 1 STP l /sec and a typical beam flux (50% of theoretical efficiency) would be $\sim 10^{26}$ molecules/sec-sr with an estimated Mach number $M = 110$, and a high degree of focussing (half-angle of divergence $< 1^\circ$). Skimmer design should probably allow for adjustable aperture (probably ~ 2 cm in this case) while

the angles α and β can be established a priori. Assuming $l/d = 100$, the expected density at the scattering center is $n = 10^{16}$ molecules/cm³, or about 0.1 to 1 torr partial pressure. Attenuation by background gas ($\sim 10^{-6}$ torr at -600°K) will lower the estimate somewhat. Near-ideal nozzle performance is anticipated since nozzle and skimmer imperfections can be made negligible compared to d . Radicals within the beam can be produced by heating the nozzle (3), maintaining a high pressure DC discharge (4) which is probably not feasible considering the power requirements and flow rates), or by chemical reaction within the nozzle. The last possibility has not been previously explored. The generation of F-atoms by pre-nozzle reaction of F_2 with NO may be particularly worthy of consideration.

If completely mixed, two intersecting nozzle beams as described above would produce primary products nearly stoichiometrically for a cross section $\sigma_R = 1\text{\AA}^2$ or greater. A problem arises, however, because of the high probability of nonreactive collisions; one beam might be completely attenuated by the other within a fraction of a mm, although the proposed linear "collision volume" dimensions are at least ~ 2 cm. Since attenuation varies exponentially with cross section, the probability of attenuation by elastic scattering with typical cross sections of 30 to 100\AA^2 is very much larger than that for reactive scattering with $\sigma_R = 1\text{\AA}^2$ and hence implies beam deflection instead of mixing. The attenuation would be reduced considerably were the reactive and elastic cross sections more comparable; certain classes of fast reactions, e.g. metal - oxidizer, are likely to be of this type (see Section 3). The use of one adjustable weak beam might allow scanning of the transition from single to multiple reactive collisions. If appreciable conversion of the limiting reagent beam to primary products

has occurred, the most likely observable secondary reactions are those involving molecules from the large beam; again, if the secondary reactions proceed with large reactive scattering cross sections, evidence of tertiary products should be easily detectable. Observation of reactions between products from different links of the combustion chain is much less probable. It is clear, of course, that the problems of beam deflection and the emphasis on secondary reactions lead to a loss of dynamical information and tend to degrade the beam experiments to those normally carried out in low pressure flow tubes.

Electronically excited products from the reaction sequence could be detected by simple lens-filter-photomultiplier systems operated in pulse-counting mode, and vibrationally excited species by IR semiconductor devices. Resonance fluorescence could be used for atomic and diatomic ground-state products, and mass spectrometry possibly for polyatomic fragments. With as many as 10^{14} reactive events/sec occurring in the collision volume, rather large losses due to small solid angle of acceptance and low efficiency factors could be tolerated while maintaining a high signal count rate. A variety of such detectors would probably be arranged in a circular or spherical array surrounding the scattering center.

Candidate reactions may be briefly enumerated. They fall into three classes. Class A involves F_2 and F as oxidizers and H_2 or hydrocarbons as fuels. The well-studied H_2-F_2 (better H_2-F) system represents a link to dynamical single-collision studies by crossed beams (5) and by infrared chemiluminescence (6), where it would be interesting to increase beam densities experimentally until the effects of secondary reactions become observable.

Low pressure flame work with detailed mass-spectrometric sampling is also available for comparison. Fluorine atom-hydrocarbon reactions are known to give rise to infrared chemiluminescence (ϵ), and the $F_2-C_2H_2$ as well as $F_2-C_2H_2$ low pressure flames have also been examined (7).

Class B includes metal-oxidizer reactions where the metals range from the alkalis to the earth alkalis and beyond, and the oxidizers are mainly NO_2 , N_2O , O_3 , $NOCl$, etc. Large chemiluminescent yields have recently been reported⁹ for some reactions of Ba and have excited interest in the possibility of chemical lasers in the visible. The cross sections of some of these reactions are greater than $10A^2$ which should diminish the beam deflection problem. The production of metal atom beams of large size and flux is likely to be a major obstacle. Possibly, chemical energy in the form of thermite-type reactions could be utilized.

Class C contains more complex molecule-molecule systems such as hydrazine-nitrogen oxides, for which less information is available regarding sequences of elementary reactions and specific excitation steps resulting in chemiluminescence.

Another, quite different class of experiments may also be taken under consideration, although it does not involve crossed beams. A single, large nozzle beam of a gaseous oxidizer species may be made to impinge on a solid fuel, e.g. F_2 and F plus graphite or coal, in an effort to shed some light on gas-solid combustion interactions.

Conclusions:

Ordinary discharge-flow experiments can be arranged to show the onset and nature of secondary processes, so that the question first arises whether the proposed experiments can provide any new information on combustion kinetics. Secondly, the molecular beam system cannot be viewed as analogous to a natural flame situation, since the initial kinetic energy

of collision is well-defined (not Maxwellian) and the primary bimolecular reaction, if very fast, is likely to produce strongly polarized scattering of the primary products. Such conditions, while of interest to chemical dynamicists, do not lend themselves toward understanding the mechanism of combustion initiation. Thirdly, as noted above, use of high densities may lead to severe beam mixing problems if the primary process is too slow, i.e., if too much beam intensity is needed to produce sufficient buildup of product concentrations. Thus, the number of systems conducive to study may be quite small.

An answer to the first objection is not easily given, since introduction of such high-density conditions in a beam experiment obviates the usual use to which such experiments are put. It is possible, by elimination of vessel walls, that a beam experiment in space may more clearly delineate the most important chain propagating reactions. By confining most reactive events to a relatively small spatial region, detection of products becomes relatively straight-forward.

The second objection is not forbidding for very fast reactions, since these will necessarily have little or no activation energy. The reaction cross section will then not depend strongly on energy, so that it makes little difference whether a Maxwellian or monochromatic collision energy distribution prevails. Strongly anisotropic scattering of the primary products may produce a spatial inhomogeneity in the reaction volume, but this can probably be anticipated in the design and location of specific detectors. Conventional laboratory observations of the primary reaction (if not already available) would be needed.

The limitation of the number and type of suitable reaction systems is serious, but must be accepted if any advantages gained by using beams are to be realized. It is clear, moreover, that any investigation which does

not require the special conditions of the space environment, i.e. the unlimited pumping capacity in this case, is better carried out in an ordinary laboratory. Detailed calculations would also have to be carried out regarding the forces exerted on the Space Shuttle by the operation of such beams.

It seems clear that the proposed experiments fall into an awkward range where the advantages of beam dynamics are lost and one may not have much hope of realizing scientific goals which could not have been obtained more easily in low pressure flow tube experiments or flames. For the H_2-F_2 system, for example, even if the initial $H_2 + F$ reaction were to produce sufficiently large amounts of vibrationally excited HF^* , the latter, upon reaction with F_2 (along with the more energetic HF^* from the $H + F_2$ reaction) would only produce more F , and would not easily provide significant information. It appears, then, that the combination of proper (earth-based), single-encounter crossed beam work, plus flow tube, chemiluminescence, and flame studies are likely to pre-empt the present approach. Our conclusion is, therefore, that large chemical beam combustion in space does present some possibility of producing new information on combustion initiation for certain systems, but that there are serious questions regarding feasibility, general applicability and ultimate value of such experiments.

References:

1. For general reviews, see (a) D. R. Herschbach, *Adv. Chem. Phys.* 10, 319 (1966); (b) J. L. Kinsey, in *Physical Chemistry 9, Chemical Kinetics* (MTP International Review of Science, 1971)p. 173; (c) D. R. Herschbach, *Faraday Disc. Chem. Soc.* 55, 233 (1973).
A general review of techniques is given by (d) H. Pauly and J. P. Toennies in *Methods of Experimental Physics*, Vol. 7A, p. 227.
2. (a) J. B. Anderson, R. P. Andrej, and J. B. Fenn, *Adv. At. Mol. Phys.* 1, 345 (1965); *Adv. Chem. Phys.* 10, 275 (1966); a recent appraisal is given by (b) U. Bossel, *Entropie* 42, 12 (1971); see also Ref. 1 (d) pp 237-255.
3. L. T. Cowley, D. S. Horne, J. C. Polanyi, *Chem. Phys. Lett.* 12, 144 (1971); Y. T. Lee, Private Communication.
4. J. Q. Searcy, *Rev. Sci. Instrum.* 45, 589 (1974).
5. T. P. Schafer, P. E. Siska, J. M. Parson, F. P. Tully, Y. C. Wong and Y. T. Lee, *J. Chem. Phys.* 53, 3385 (1970).
6. J. C. Polanyi and K. B. Woodhall, *J. Chem. Phys.* 57, 1574 (1972).
7. K. H. Homann and D. I. MacLean, *Ber. Bunsenges.* 75, 945 (1971).
8. H. W. Chang and D. W. Setser, *J. Chem. Phys.* 58, 2298 (1973).
9. C. R. Jones and H. P. Broida, *J. Chem. Phys.* 59, 6677 (1973)
R. H. Obenauf, C. J. Hsu, and H. B. Palmer, *J. Chem. Phys.* 53, 2674, 4693 (1973).

V. SOME COMBUSTION LABORATORY REQUIREMENTS

Discussion:

Before entering into a discussion of laboratory hardware, the sense of the Study Group concerning the operational modes of research should be given. Once an experimental Space Shuttle research program is decided upon, its implementation may be expected to differ strikingly from that which we indulge in earth-based experiments. Earth-based combustion experiments are conducted by people who generally have an outstanding knowledge of "safety". Clearly this knowledge is less secure at reduced gravitational fields. Earth-based combustion experimentation generally does not utilize fully our ability to quickly and automatically measure, record, digitize, analyze and thereby continually guide the experimentation process. To the extent possible, Space Shuttle experimentation must avoid these deficiencies. In addition to the appropriate space-based hardware, then, we require the concurrent ability to analyze observations on the earth and to provide continuing theoretical and experimental guidance from earth. During Space Shuttle Combustion experimentation, only part of the combustion research team may be expected to be in orbit.

The experimentation proposed in Sections IV.1.-IV.10. imply a broad range of combustion instrumentation. Nonperturbing devices for fast response measurements of temperature, pressure (spectrally resolved) radiative flux density, and chemical composition are highly developed.

The application of appropriate modification of these devices to the measurement of the temperature, composition, and radiative structure of flames, the characteristic sizes of burning drops or particles, flow field characteristics, etc. appear straightforward. However, the nonperturbing (in situ) measurement of mass is not.

A common capability of any scientific laboratory is that associated with the determination of mass. This determination may be made in preparation for experimentation (e.g. the mass of a sample of a chemical reactant) or in situ experimentation (e.g. measurement of the rate of mass loss for burning array of solid fuel elements during a combustion experiment (1)). These determinations are generally accomplished through "weighing" experiments (1) involving the use of "balances", "load cells", and other devices whose performance depends upon the existence of a significantly nonzero, constant gravitational field.

In combustion (and other) experiments on Space Shuttle, the aforementioned class of mass measuring devices is inadequate (2). The Study Group recommends that NASA undertake the development of mass measuring instrumentation capable of meeting anticipated needs.

References:

1. Berlad, A. L., Kothermel, R.C. and Francsen, W. "The Structure of Some Quasi-Steady Fire Spread Waves". XIII Symposium (International) on Combustion. The Combustion Institute (1971).
2. Berlad, A. L. and Krishna, C. R. "Transport Mechanisms in Fire Spread and Extinction". Paper presented at the Clay Preston Butler Anniversary Meeting on Experimental Methods in Fire Research, Stanford Research Institute (May 1974), in press.

VI. CONCLUSIONS AND RECOMMENDATIONS

The NASA-PSRI Study Group has addressed a basic set of questions. Namely, given the opportunity to engage in combustion experimentation which utilizes the space laboratory facilities of the Space Shuttle:

- (a) What basic physical processes associated with the space environment may affect combustion phenomena? What are these effects?
- (b) What fundamental areas of combustion experimentation are expected to benefit from being conducted in a space environment? How and why?
- (c) What priorities and recommendations can be provided to help guide the implementation of a program for such experimentation?

Previous sections of this report have dealt, in depth, with questions (a) and (b) and implicitly with (c). It is now necessary to address question (c) more explicitly.

Underlying our previous discussions are the dominant physical effects that derive from a space environment:

- (a) $g=0$, as well as programmed g -fields on the range $0 \leq g \leq 1$ are available for relatively long times.
- (b) Within both gaseous and liquid states, free convection can be eliminated; also, free convection effects can be experimentally selected and controlled via the selection and control of (g) .

- (c) prior to and during combustion, homogeneous and/or invariant two-phase fuel oxidant distributions can be created and maintained at $g=0$ that are not experimentally possible at $g=1$.

Virtually unlimited "pumping capacity" as well as the upper atmosphere temperature, composition, and radiative characteristics may also prove important. But the implications for basic combustion studies of effects (a) - (c) are profound. They make possible:

- (a) a broad range of combustion experimentation in a space environment that is inaccessible on earth.
- (b) combustion experiments involving the selected coupling (and decoupling) of free convection to other transport processes.
- (c) identification of the specific experimental roles of free convection in a wide range of combustion phenomena and, derivatively, the roles of other combustion subprocesses.
- (d) systematic experimentation to importantly determine the combustion characteristics of two-phase systems. These include individual particles and drops, clouds of particles and drops, arrays of solid fuel elements, large solid-gas and large liquid-gas combustible systems.
- (e) systematic experimentation to provide the observational

bases for theoretical formulations where current theory is inadequate.

- (f) selected experiments to provide specific answers to key questions for which $g=1$ experimentation is inadequate.

Detailed discussions of many experiments of substantial importance appear in earlier sections of this report. Associated with each such proposed experimental program is a set of important theoretical questions that are currently unanswered. The theoretical modeling necessary to utilize the results of the proposed experimentation is extensive.

The review of combustion experimentation (and modeling) which could benefit from the availability of a space laboratory reveals one theme that appears to dominate all others. Extensive and systematic experimentation on the range $0 \leq g \leq 1$ is viewed as essential to the development of the understanding required in virtually all the major fundamental areas of combustion. Current theory has not been adequately guided by experiment. Current (drop tower) facilities for $0 \leq g \leq 1$ experimentation have an important role to play in future studies. But these roles are necessarily limited. Only an orbital space laboratory can provide the scales of time and space necessary to exploit substantially the scientific goals of combustion experimentation in a space environment. These conclusions apply for:

- (a) Premixed Flame Propagation and Extinction Limits
- (b) Theory of Noncoherent Flame Propagation
- (c) Upper Pressure Limit Theory of Ignition and Flame Propagation

- (d) Autoignition for Large Premixed Gaseous Systems
- (e) Cool Flames in Large Premixed Gaseous Systems
- (f) Burning and Extinction of Individual Drops or Particles, Over Very Large Ranges of Pressure
- (g) Ignition and Autoignition of Clouds of Drops and/or Particles, Over Very Large Ranges of Pressure.
- (h) Two Phase Combustion Phenomena Involving Large Liquid-Gas or Solid-Gas Interfaces.
- (i) Radiative Ignition of Solids and Liquids
- (j) Pool Burning and Flame Propagation Over Liquids
- (k) Flame Spread and Extinction Over Solids
- (l) Smoldering and Its Transition To Flaming (or Extinction)
- (m) Laminar Gas Jet Combustion
- (n) Coupling (or Decoupling) of Convectively-Induced Turbulence Involved In Various Combustion Phenomena
- (o) Transient Responses of Flames To Time-Dependent (Effective) Gravitational Fields.

This is a partial listing of the many valuable experimental and theoretical programs that can be carried out with the essential facilities provided by a Space Environment. Several of these programs show particularly outstanding promise. In this latter category must be included the areas of:

- (1) Extinction Limits in Premixed and Unpremixed Gases
- (2) The Many Diverse Areas of Two Phase Combustion, Particularly the Combustion of Single Drops and Particles.

Arrays of Drops and Particles, Clouds of Drops and Particles,
Arrays of Solid Fuel Elements, and Liquid Pools.

The extent to which other noted (or uncited) combustion studies will revolutionize our understanding of the Fundamentals of Combustion depends largely on the ingenuity of experimenters and theorists who have yet to address the scientific opportunities that space-based combustion experimentation can provide.

1. APPENDIX A - "Specimen of
Letter Used To Solicit
Technical Views of the
Combustion Community"



PUBLIC SYSTEMS RESEARCH, INC.
1320 Stony Brook Road Stony Brook, New York 11790
516-751-4515

NASA-SPONSORED COMMITTEE FOR THE
STUDY OF COMBUSTION EXPERIMENTS
IN SPACE

Dear Colleague:

You may be aware of the fact that the undersigned constitute a committee that has been charged with identifying and evaluating a series of specific, basic combustion experiments that would be desirable to conduct in a space environment. The space laboratory facilities envisioned are those associated with the Space Shuttle Program. Our committee operates under joint aegis of NASA and of Public Systems Research, Inc. (a not-for-profit research institute).

We recognize the importance of your work and that of your laboratory in fundamental combustion research. Accordingly, we solicit your help in furthering the work of the committee.

The NASA Space Shuttle will offer scientists and engineers the opportunity to conduct a variety of experiments in a space environment. The conditions so provided (e.g. reduced gravitational conditions, a convectionless environment, a unique radiative field, etc.) allow experimental approaches to information that cannot be obtained on Earth.

The committee has initially identified the following combustion research areas which may be expected to benefit substantially from experimentation in a space environment: Fire Research, Two-Phase Combustion, Combustion Product modifications, Oscillatory Flames, Ignition and Autoignition, Flammability and Extinction Limits, Combustion with Large Chemical Beams, Inhibition of Flame

Propagation, Gravitational Scaling of Flame Systems.

We seek your considered views regarding these (as well as other) fundamental areas of combustion research which may benefit from Space Shuttle experimentation.

Please keep in mind that your response to this letter, and all reports of the committee to NASA, are in the public domain. Nevertheless, NASA anticipates that there will be an opportunity to submit proposals at a later time and that the best experiments will be considered for NASA funding.

Please feel free to contact any member of the committee regarding any aspect of this study.

Your assistance is greatly appreciated.

Sincerely yours,

A.L. Berlad, Chairman
Clayton Huggett
Frederick Kaufman
George H. Markstein
Howard B. Palmer
Ching H. Yang

br
enc.

2. APPENDIX B



"Minutes of the Three Meetings of the Study Group"

PUBLIC SYSTEMS RESEARCH, INC.
1320 Stony Brook Road Stony Brook New York 11790
516-751-4515

Minutes of the 30 March 1974 NASA-PSRI Meeting on
COMBUSTION EXPERIMENTS IN SPACE

1. Attending: A.L. Berlad, T. Cochran (NASA), S. Harrison, C. Huggett, F. Kaufman, G. Markstein, H. Palmer, J. Swartz, C.H. Yang
2. Agenda:
 - (a) Preliminaries (PSRI)
 - (b) Space Shuttle Background and Constraints (NASA)
 - (c) Time Frame for SSG Activities
 - (d) Scheduling of future SSG meetings
 - (e) Working session
3. Substantive understandings and plans of action:
 - (a) Current schedule of future SSG meetings in Stony Brook
 - (i) Monday, June 3, 1974
 - (ii) Saturday, July 27, 1974
 - (b) Combustion experiments and Areas of Interest that were discussed as candidates of possible importance to space shuttle experimental opportunities (in order of discussion):
Burning of a single condensed phase particle in a gaseous medium; Burning of a cloud of particles in a gas phase medium; mine safety and allied explosive problems; Flammability and extinction limits; autoignition limits; oscillatory flames; Point source ignition; Changing of safety conditions in space environments; Fire extinguishment; Shock tube ignition of two-phase systems; radiative ignition of solids; pollution-related problems; soot formation in unpremixed flames; gravity-field scaling in experimental systems; particulates generated in forest fires; low velocity criticality in opposed-jet flame experiments; interaction of [O]-atoms with carbon; heat transfer coefficients from hot-wire experiments; radiative-convective coupling in fire propagation; smouldering in two-phase systems; extinguishment roles of H₂O and other compounds; surface tension effects on states of reactants; flame sustained Lasers; deflagration-detonation transition dynamics; large beam combustion phenomena.

- (c) The above items were broadly grouped (necessarily overlapping) and the indicated SSG members agreed to pursue the primary tasks I, II, III (of the NASA-PSRI agreement) during the forthcoming period. The categories and associated responsibilities are:
- (i) Fire Research: Dr. Huggett*, Dr. Markstein
 - (ii) Two-Phase Combustion: Dr. Palmer*, Dr. Berlad, Dr. Yang
 - (iii) Combustion Product Effects: Dr. Palmer*, Dr. Kaufman
 - (iv) Oscillatory Flames: Dr. Yang*
 - (v) Ignition-Autoignition: Dr. Yang*, Dr. Berlad
 - (vi) Flammability Limits and Extinction: Dr. Berlad*, Dr. Palmer, Dr. Yang
 - (vii) Large Beam Combustion: Dr. Kaufman*
 - (viii) Flame Inhibition Effects: Dr. Huggett*, Dr. Markstein, Dr. Palmer
 - (ix) Gravitational Scaling: Dr. Markstein*

*(Lead responsibility)

The above categories constitute an initial listing of combustion areas of study which promise to benefit substantially from experimentation in a space environment.

4. Communications with the scientific community:

Guidelines for the attached (specimen) letter were generated. These include:

- (a) a need to invite broad interest and support for the SSG's activities.
- (b) a need to discourage proprietary inputs, though encouraging adequately detailed suggestions from the scientific community.

This letter is being distributed by each SSG member, in the spirit of our discussions, to a broad list of individuals and institutions. Individual SSG members are encouraged, on their separate initiatives, to broaden the base of these contacts both nationally and internationally.

Dr. Berlad is to be kept informed, on a continuing basis, of all significant contacts. PSRI will maintain a composite record of these contacts. Additionally, as replies are received by individuals, copies of substantive communications should be provided to:

- (i) Dr. Berlad, for general information and archival purposes.
- (ii) SSG members most concerned with the inputs contained therein.

A.L. Berlad



PUBLIC SYSTEMS RESEARCH, INC.
1320 Stony Brook Road Stony Brook New York 11790
516-751-4515

Minutes of the 3 June 1974 NASA-PSRI Meeting on
COMBUSTION EXPERIMENTS IN SPACE

1. Attending: A. L. Berlad (SUNY at Stony Brook)
T. H. Cochran (NASA)
E. Conway (NASA)
S. A. Harrison (PSRI)
F. Kaufman (U. of Pittsburgh)
G. H. Markstein (Factory Mutual Research Corp.)
H. B. Palmer (Penn State University)
J. Swartz (PSRI)
R. A. Strehlow (University of Illinois)
C. H. Yang (SUNY at Stonybrook)
2. Agenda:
 - (a) Preliminaries
 - (b) Space Shuttle Planning (NASA)
 - (c) Interaction with the scientific community
 - (d) Current views of the most promising research
 - (e) Specific experiments and their anticipated worth
 - (f) SSG planning for the forthcoming period
3. Substantive understandings and discussion highlights:
 - (a) The next SSG meeting is scheduled for Saturday, July 27, 1974, at Stony Brook.
 - (b) Where further interaction with specific individuals in the scientific community is warranted, personal contact at the earliest time is recommended.
 - (c) Familiarization of the scientific community with this program's scientific goals and the attendant opportunities for unique research is best achieved through technical presentation and discussions at the various research forums which are central to the combustion community's activities.
 - (d) The nine combustion research areas noted in 3-c of the 30 March 1974 minutes were discussed and the currently most promising experiments identified.

- (e) Technical support and laboratory instrumentation, commonality of experimenters' needs and suitability of existing equipment were examined.
4. Preparation for the 27 July meeting:
- (a) At an early date, NASA and PSRI will provide tentative outline to accommodate a final report.
 - (b) Each member of the SSG will be asked to deal with one or more specific portions of the report. In its final form, each such portion will appear beneath the author's name.
 - (c) Introductory, connective, and summary portions of the report will be prepared by A. L. Berlad, in behalf of the Committee.
 - (d) Information regarding these efforts will be distributed shortly to each of us to bring "working drafts" to our 27 July meeting, for discussion.
5. The primary emphasis of SSG efforts during the forthcoming period shifts from Tasks (I) and (II) to Tasks (III) and (IV), as spelled out in the NASA-PSRI agreement.

A. L. Berlad



PUBLIC SYSTEMS RESEARCH, INC.
1320 Stony Brook Road Stony Brook New York 11790
516-751-4515

Minutes of the 27 July 1974 NASA-PSRI Meeting on
COMBUSTION EXPERIMENTS IN SPACE

1. Attending: A.L. Berlad (SUNY at Stony Brook)
T.H. Cochran (NASA)
C. Huggett (NBS)
A.M. Kanury (Stanford Research Institute)
F. Kaufman (U. of Pittsburgh)
G.H. Markstein (Factory Mutual Research Corp.)
P.S. Myers (U. of Wisconsin)
E.E. O'Brien (SUNY at Stony Brook)
H.B. Palmer (Penn. State University)
J. Swartz (PSRI)
C.H. Yang (SUNY at Stony Brook)

2. Agenda:
 - (a) Preliminaries and review
 - (b) Detailed discussion of the most promising research areas and leading experiments.
 - (c) Elements of our final recommendations
 - (d) Proposed Final Report. Contents, assignments, and delivery schedules.

3. Substantive understandings and meeting highlights:
 - (a) Preliminary drafts of Minireports were exchanged for purposes of internal review and comment. Members of the SSG are asked to provide individual authors with comments by Friday, August 2, 1974. Final versions of the Minireports are to be received by A.L. Berlad by August 9.
 - (b) Contents of individual minireports will reflect levels of importance and promise of the specific avenues of research deemed to be significant and worthy.
 - (c) Inputs to all elements of the Final Report (due very shortly) are solicited. Please write and/or call the undersigned.
 - (d) The current outline of the proposed final report remains essentially unchanged from that distributed on 19 June. The structure of Section VI may differ from that which was previously considered.