

# N75 19136

## HANDLING PROPERTIES OF DIVERSE AUTOMOBILES AND CORRELATION WITH FULL SCALE RESPONSE DATA\*

Roger H. NICH and David H. Weir†  
Systems Technology, Inc., Hawthorne, California

### ABSTRACT

Driver/vehicle response and performance of a variety of vehicles in the presence of aerodynamic disturbances are discussed. Steering control is emphasized. The vehicles include full size station wagon, sedan, compact sedan, van, pickup truck/camper, and wagon towing trailer. Driver/vehicle analyses are used to estimate response and performance. These estimates are correlated with full scale data with test drivers and the results are used to refine the driver/vehicle models, control structure, and loop closure criteria. The analyses and data indicate that the driver adjusts his steering control properties (when he can) to achieve roughly the same level of performance despite vehicle variations. For the more disturbance susceptible vehicles, such as the van, the driver tightens up his control. Other vehicles have handling dynamics which cause him to loosen his control response, even though performance degrades.

### INTRODUCTION

Past reports of driver/vehicle studies at STI have emphasized system structure, dominant (inner loop) driver control properties, and correlations with simulator and full scale response and performance data (e.g., Refs. 1-5). Recent driver/vehicle analyses have involved a wider range of vehicle handling properties, and the corresponding full scale data have provided a better appreciation of the factors involved in estimating outer loop closure and path performance properties. These results are illustrated here following a brief background summary.

#### Assumptions and Analytical Approach

The analyses involve the application of an empirically-founded theory of driver control which is based on the more general manual control theory. These theories and models take into account a combination of:

\*This work was accomplished in part under DOT Contract FH-11-7570.

†Senior Research Engineer and Principal Research Engineer, respectively.

- Guidance and control requirements related to good stability and path following, regardless of the type of controller
- Driver-centered requirements which account for the preferences and limitations of the human driver

The driver responds to a composite of visual stimuli derived from the full visual field. These stimuli are selected such that the driver's control action serves to fulfill the guidance and control needs of the driver/vehicle system. Typically this means that more than one feedback loop will operate simultaneously (e.g., heading angle and lateral position), resulting in multiloop control.

The driver's response can be modeled using a quasi-linear model which consists in general of three components: a set of describing functions with parameters which depend on the system and situation; a set of rules which tell how to adjust the parameters; and an additive remnant.

The rationale of driver equalization can be discussed most simply by using an approximate "crossover model" (e.g., Ref. 6). Experimental data for a wide variety of both single and multiloop situations lead to the conclusion that the driver adjusts his describing function,  $Y_p$ , in each loop such that the open loop function,  $Y_p Y_c$ , comprising the effective vehicle dynamics,  $Y_c$ , and the driver in the vicinity of the gain crossover frequency,  $\omega_c$ , for that loop has the approximate form:

$$Y_p Y_c = \frac{\omega_c e^{-j\omega\tau}}{j\omega} \quad (1)$$

Here  $\tau$  is an effective pure time delay which includes the neuromuscular dynamics as well as any net high frequency vehicle lag. The crossover frequency ( $\omega_c$ ) is the product of the driver and vehicle gains. In multiloop situations the effective controlled element dynamics,  $Y_c$ , will include the effects of all the other loops closed. The form of Eq. 1 emphasizes that the driver characteristics in each loop are tailored to the specifics of the control situation and the vehicle.

The remnant is that part of the driver's output which is not linearly correlated with the input, and its major source appears to be nonstationarity in the driver's behavior. When the driver's output is treated as a power spectrum the remnant can be considered as a driver-induced broadband random "noise" injected at the driver's output. For vehicle control situations involving reasonable handling dynamics the remnant will be small compared to that part of the driver's response involved in regulating against the external disturbance. For that reason it can often be neglected in making performance estimates and comparisons. Some evidence of remnant is seen in the full scale comparisons, shown subsequently.

As noted, multiloop control involving more than one feedback stimulus is appropriate to satisfying guidance and control, and driver-centered, requirements. Prior research (e.g., Refs. 1-5) has shown that the system of Fig. 1 is representative. This involves a primary feedback loop of vehicle heading angle ( $\psi$ ), plus an outer loop of lateral deviation ( $y_I$ ). These perceptual cues are operated on by the driver describing functions ( $Y_{p\psi}$  and  $Y_{p_y}$ ) to produce a steer angle correction ( $\delta_w$ ).

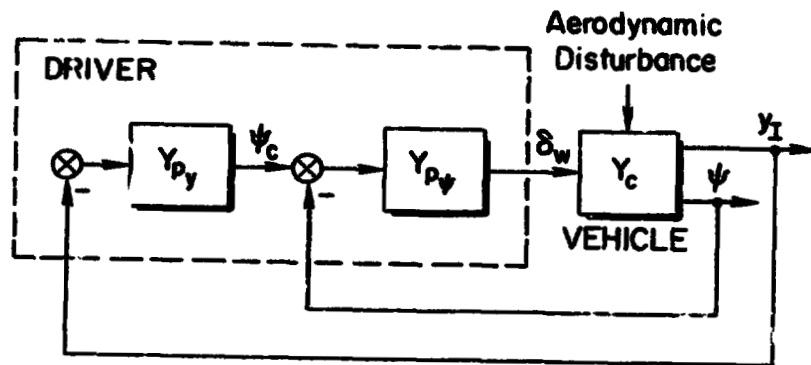

Figure 1. Driver/Vehicle System Block Diagram

The driver describing functions in Fig. 1 can be quantified by using a sequential application of the crossover model; beginning with  $Y_{p\psi}Y_c$  in the inner loop and then considering  $Y_{p_y}Y_c'$  in the outer loop, where  $Y_c'$  denotes the effective vehicle dynamics with the heading angle feedback closed.

#### Vehicle Dynamics

The controlled element (vehicle) dynamics are a major task variable. The lateral-directional properties pertinent to steering control were modeled using 3 degree of freedom linear equations of motion. For a single vehicle the variables are:

- Lateral velocity ( $v'$ )
- Heading rate ( $r$ )
- Roll angle ( $p$ )

Two additional degrees of freedom result when a towed trailer is added, i.e.:

- Trailer tow angle ( $\eta$ )
- Trailer roll angle ( $q_t$ )

The equations of motion and corresponding transfer functions were quantified using chassis and tire data and verified by full scale tests. The resulting heading angle and lateral position transfer functions are given in Table 1. The transfer functions are:

$$\frac{\psi}{\delta_w} = \frac{sN_{\psi}^{\psi}}{s^2\Delta}$$

$$\frac{y_I}{\delta_w} = \frac{s^2N_{\psi}^{y_I}}{s^2\Delta}$$

Note that the denominator free  $s$  terms are not shown in the table for simplicity. Further details on the equations and vehicle properties are given in Ref. 7.

TABLE 1. SUMMARY OF VEHICLE TRANSFER FUNCTIONS

VEHICLE	TRANSFER FUNCTION POLYNOMIAL		
	HEADING NUMERATOR, $sN_{\delta_w}^{\psi}$	LATERAL DEVIATION NUMERATOR, $s^2N_{\delta_w}^{yI}$	DENOMINATOR, $\Delta$
1972 Wagon	22(3.8)[.22, 10.7]	11(7.0)[.30, 8.0][.01, 8.7]	.55[.70, 4.4][.24, 11.3]
1972 Wagon Plus Trailer	92(3.1)[.26, 4.4] × [.16, 8.3][.18, 10.2]	710[.27, 4.7][.29, 6.9] × [.07, 8.2][.15, 8.3]	4[1.0, 3.2][.24, 4.1] × [.16, 8.3][.23, 11.0]
Compact Sedan	2.6(2.2)[.53, 15.2]	21[.13, 7.5][.20, 7.5]	.24(.73)(4.1)[.62, 16.6]
Truck/Camper	21(4.1)[.21, 4.7]	14(5.0)[.17, 4.7][.15, 6.3]	.75[1.0, 4.0][.15, 4.6]
1972 Sedan	31(4.0)[.2, 9.8]	270[.33, 7.7][-.03, 8.1]	.41[.53, 6.2][.43, 15.9]
Imported Van	6.7(4.8)[.52, 13.4]	74[.17, 9.0][.18, 9.2]	.37[.64, 4.6][.48, 13.3]

The shorthand notation for polynomial factors is:  $A(s + a)$  is written  $A(a)$ ;

$A[s^2 + 2\zeta\omega s + \omega^2]$  is written  $A[\zeta, \omega]$

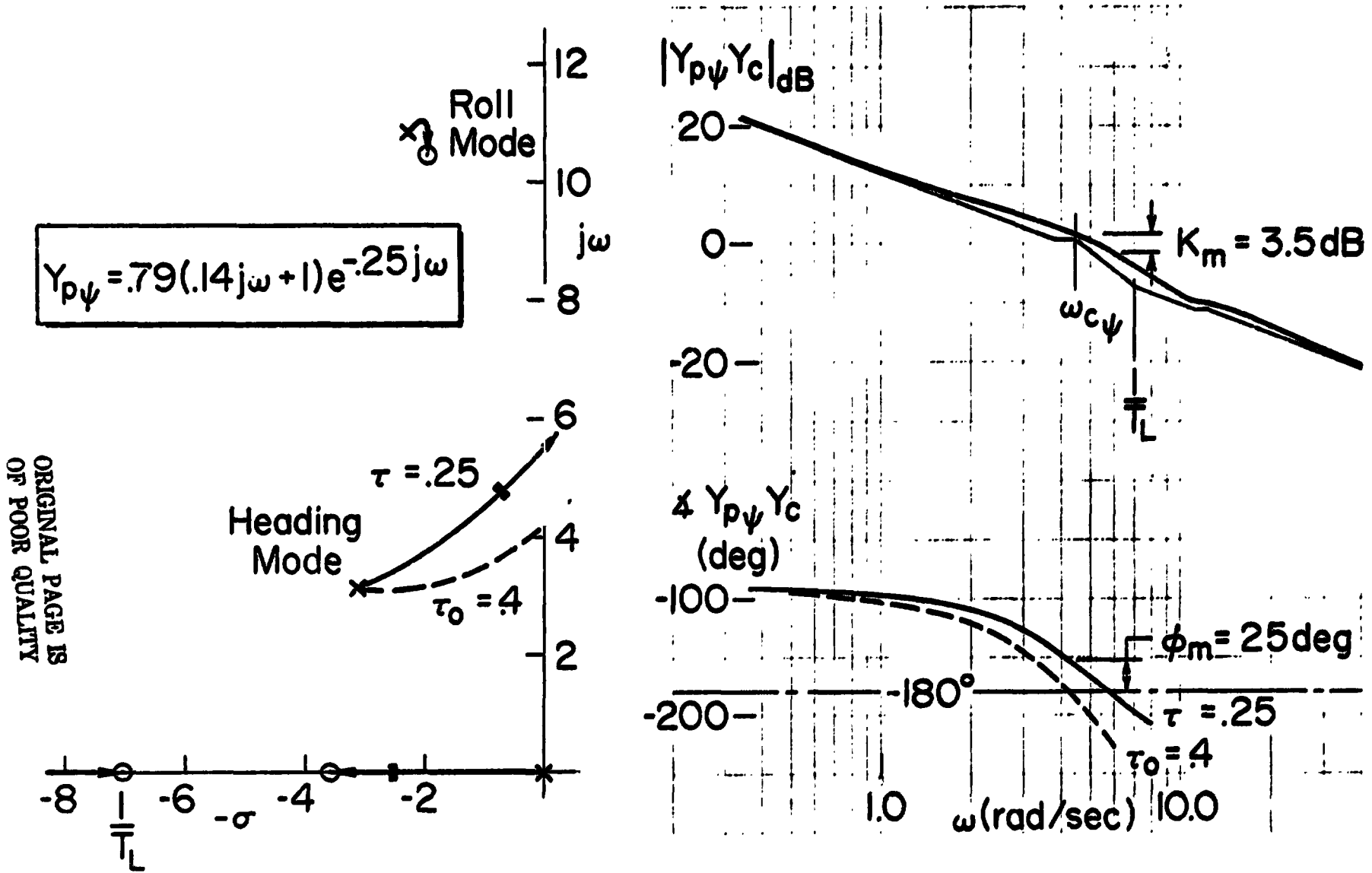

Figure 2. Driver/Vehicle Response Properties for Heading Control, 1972 Station Wagon at 60 mph

ORIGINAL PAGE IS OF POOR QUALITY

For the vehicles shown in Table 1 the required equalization can be accounted for in  $Y_{p\psi}$ , and the driver time delay,  $\tau$ , can be included there, also, by virtue of the "series" structure in Fig. 1. The effective forcing function bandwidth resulting from a typical aerodynamic disturbance is about 1 rad/sec for the vehicles shown in Table 1.

#### Driver/Vehicle Response Analyses and Full Scale Comparisons

The procedures and model outlined above were used to estimate the response and performance of the several driver/vehicle systems in the presence of a bus-induced aerodynamic disturbance. In the discussion the analytical results are shown, then the computed performance results are compared with the recorded full scale time responses. The 1972 station wagon is treated first in some detail, as the base case. This is followed by the results for the other vehicles.

**1972 Station Wagon** — The driver/vehicle response properties ( $Y_{p\psi} Y_c$ ) for the heading loop are shown in Fig. 2. A root locus plot is on the left and a frequency response (Bode) plot is on the right. The vehicle dynamics ( $Y_c = \psi/\delta_\psi$ ) are taken from Table 1. A suitable Padé approximation is used for the driver time delay term,  $e^{-T_d s}$ . The nominal result in Fig. 2 is for driver lead equalization ( $T_L$ ) of 0.14 sec and a net driver time delay of 0.27 sec. The amplitude ratio of the frequency response plot shows that the lead of 0.14 sec satisfies the equalization needs of Eq. 1 and makes the slope -20 dB/dec (corresponding to  $|K/j\omega|$ ) in the mid frequency region. For this amount of driver lead equalization and no disturbance input the driver time delay ( $\tau_D$ ) is about 0.35 to 0.4 sec; and the corresponding zero phase margin crossover frequency,  $\omega_{c_0}$ , is about 4.2 rad/sec. The presence of the disturbance increases the driver's neuromuscular tension and reduces  $\tau$  to about 0.27 sec; resulting in about 25 deg phase margin ( $\phi_m$ ) and 5 dB gain margin ( $K_m$ ) for the same crossover frequency,  $\omega_{c_\psi} = 4.2$  rad/sec. The nominal driver describing function in the heading loop for the 1972 station wagon becomes:

$$Y_{p\psi} = .79(.14j\omega + 1)e^{-.27j\omega} \quad (2)$$

In practice, a high frequency lag ( $T_L \approx 0.01$ , say) can be used to complete the equaliser.

Heading and roll "modes" are shown on the root locus of Fig. 2. These refer to the roots of the vehicle characteristic equation, and they are associated with the corresponding heading and roll dynamics of the basic vehicle. For example, the natural frequency and damping ratio of the roll mode is determined largely by the springs, shock absorbers, and sprung mass inertial properties of the vehicle.

The effect of changing the driver's response properties can be inferred from Fig. 2. Decreasing driver lead equalization will result in a decrease in crossover frequency for constant stability margins. This will reduce closed loop system bandwidth and degrade performance. Similar results occur for increased driver time delay, or with increased lag from the vehicle's dynamics.

Closing the heading loop, above, is the first of two analytical steps. It results in an open "outer loop" effective controlled element ( $Y'_c$ ) which is to be combined with the driver's describing function for lateral deviation control ( $Y_{p\psi}$ ). Closing this outer loop by again applying the crossover model of Eq. 1 is the second step. The open outer loop system block diagram is shown in Fig. 3. The driver/vehicle response properties for lateral deviation control are shown in Fig. 4.

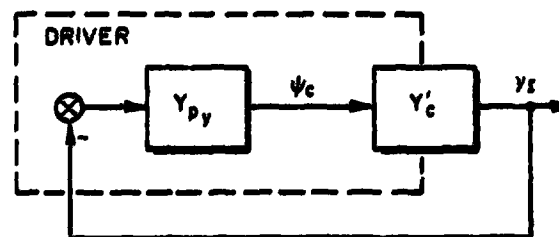

Figure 3. Block Diagram for Analysis of Lateral Deviation Control

P-157

-197-

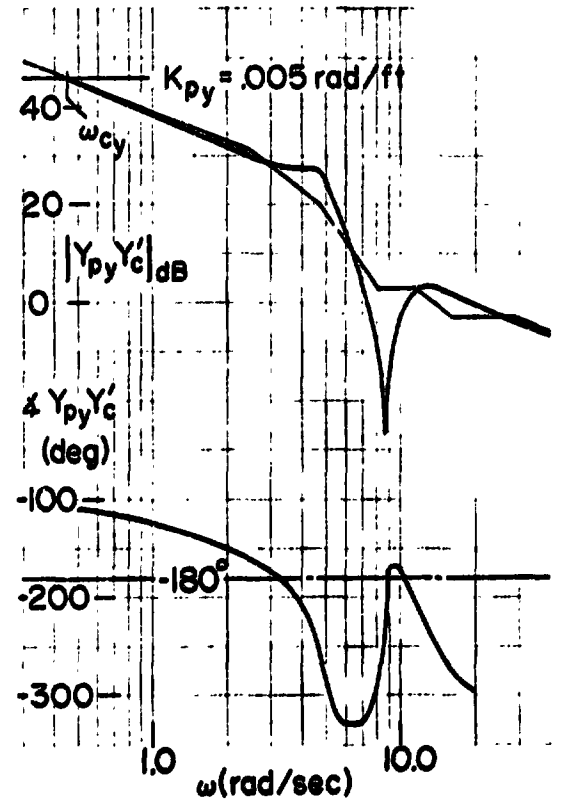
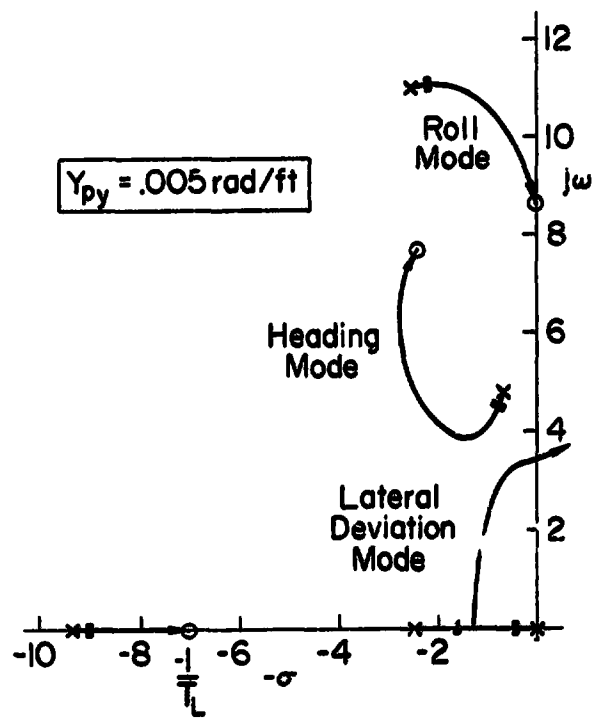

Figure 4. Driver/Vehicle Response Properties for Lateral Deviation Control, 1972 Station Wagon at 50 mph

The frequency response shows a broad region of  $K/j\omega$ -like amplitude ratio which will allow the driver to use a proportional control and vary his lateral deviation loop gain ( $K_{py}$ ) over a considerable range depending on his closure criteria.

Selection of the outer loop crossover frequency ( $\omega_{cy}$ ) in Fig. 4 can depend on several factors. Within limits, higher crossover frequencies give a wider driver/vehicle system bandwidth which improves performance by reducing lateral deviation error. The penalty associated with this is an increase in driver workload, and he will (when he can) adjust to some level of control which gives acceptable lane keeping performance. If the crossover frequency becomes too high performance will deteriorate because of reduced path damping and stability margins. For some vehicle handling dynamics, the quality of the response becomes poor for crossover frequencies well below the stability limit, as a result of undesirable interaction between the directional modes. In summary, the driver will increase his level of activity (crossover frequency) to achieve the desired level of performance, as long as he does not encounter undesirable vehicle handling properties in the process.

In view of these factors, the estimated value of  $\omega_{cy}$  becomes 0.46 rad/sec, which corresponds to  $Y_{py} = 0.005$  rad/ft for this vehicle. Larger values of  $\omega_{cy}$  would not reduce the stability margins but they would result in poor response qualities, as follows. Consider the effect of increasing the crossover frequency in Fig. 4. For low values of  $\omega_{cy}$ , the lateral deviation and heading mode roots are well separated on the root locus, resulting in relatively simple response qualities which are dominated by the lateral deviation mode. As  $\omega_{cy}$  is increased, the closed-loop roots of the lateral deviation and heading modes approach each other. This results in a more complex, fourth order disturbance response, consisting of a combination of the two modes. Physically this means that the practical region of control is restricted by an undesirable interaction of lateral deviation and heading loop modes, although the region of stable control is large.

The disturbed vehicle's sensitivity to aerodynamic inputs also affects the driver's outer loop control effort. More sensitive vehicles require

higher crossover frequencies to maintain a given range of performance. The station wagon is relatively insensitive so this factor did not override the response quality considerations described above.

The estimated driver/vehicle response characteristics, plus the aerodynamic disturbance data of Ref. 8, were used to compute the driver control and vehicle motion time responses for a given situation. Comparisons of such computed results with corresponding full scale data are given in Fig. 5. The test conditions involved the 1972 station wagon passing an intercity bus in about a  $-20$  deg crosswind at a speed of 7 mph (bus 56 and wagon 63). The nominal (undisturbed) bus-vehicle centerline separation was about 12 ft. In the full scale data of Fig. 5, the mean front wheel steer angle is given by  $\delta_w$ ,  $U_c$  is the station wagon speed,  $r$  is the heading rate, and  $|WV|$  and  $\phi_{WV}$  are the magnitude and angle of the wind relative to the moving car. The lateral deviation of the station wagon relative to its nominal lane centerline is given by  $y_T$ . The data derive from the Ref. 7 study.

The lateral deviation results show excellent agreement, as do the low frequency variations in driver steer angle. The higher frequency remnant in steer angle,  $\delta_w$ , and heading rate,  $r$ , occurs at the inner loop crossover frequency. As discussed, driver remnant can be included in the driver model when desired, but its effects on performance are minimal, as illustrated by the good match between the analytical and full scale lateral deviation time histories. This agreement in the lateral deviation comparison confirms the choice of outer loop crossover frequency shown in Fig. 4,  $\omega_{cy} = 0.46$  rad/sec.

Station Wagon Plus Trailer — Addition of the single axle travel trailer to the station wagon had a considerable effect on both the basic handling dynamics and the response of the driver/vehicle system to a bus-induced disturbance.

Root locus and frequency response plots of the heading loop driver/vehicle dynamics are shown in Fig. 6. Compared to the station wagon alone, the main effect of adding the trailer is to increase the mid frequency phase lag of the vehicle dynamics ( $Y_c$ ) which tends to reduce the attainable driver

ORIGINAL PAGE IS  
OF POOR QUALITY

crossover frequency. [The difference in speed between 60 and 65 mph has only a small effect on the vehicle dynamics.] Application of the previously discussed driver model rules resulted in a heading loop driver lead ( $T_L$ ) at 0.33 sec, and a driver time delay ( $\tau$ ) of 0.25 sec. Comparison of the open loop heading roots of the station wagon (Fig. 2) with the wagon plus trailer (Fig. 6) shows that the trailer results in two additional modes (trailer roll and tow angle). The trailer tow angle mode is seen to be lightly damped, and this causes the initial instability as the driver increases his inner loop crossover frequency. Note that the station wagon heading mode remains quite well damped for all values of driver gain. Physically this means that the driver may be relatively unaware of large oscillations of the trailer. This analytical interpretation was borne out in the full scale tests where the driver comments indicated he was unaware of the typically large trailer oscillations.

The characteristics of the outer loop driver/vehicle response properties for the wagon plus trailer are shown in Fig. 7. Again, simple gain control ( $K_{py}$ ) is adequate in the outer loop, and the crossover frequency ( $\omega_{cy}$ ) is limited by the vehicle's handling dynamics.

An example comparison of full scale data and analytical results for zero crosswind is shown in Fig. 8, and the agreement is seen to be quite good. The tow angle is 0. The lateral deviation trajectory\* ( $y_{Ic}$ ) in Fig. 8 shows that the trailer tends to move towards the bus in a zero crosswind condition, while the station wagon alone (and all other tested vehicles) tended to move away from the bus in this wind condition. This difference results from the aerodynamic disturbance of the trailer.

Truck/Camper — The driver/vehicle response properties of the truck/camper are given in Figs. 9-11. The system surveys of the heading and lateral deviation loops are presented followed by a time history of an analytical/full scale comparison. The truck/camper heading loop closure (Fig. 9) is similar to the wagon plus trailer (Fig. 6). The basic vehicle dynamics

\* $y_{Ic}$  refers to deviation of a point on the rear bumper of the trailer. This is done to account for the effect of trailer tow angle on lateral deviation.

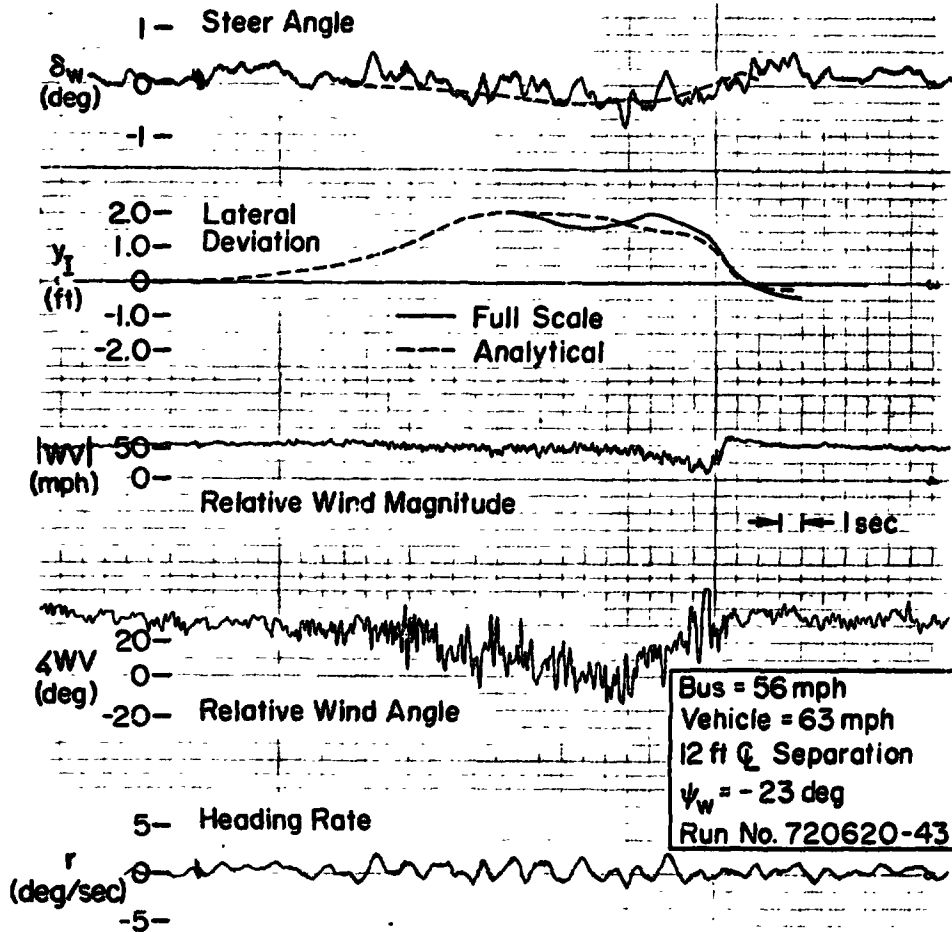

Figure 5. Comparison of Analytical and Full Scale Results, 1972 Station Wagon Passing Intercity Bus



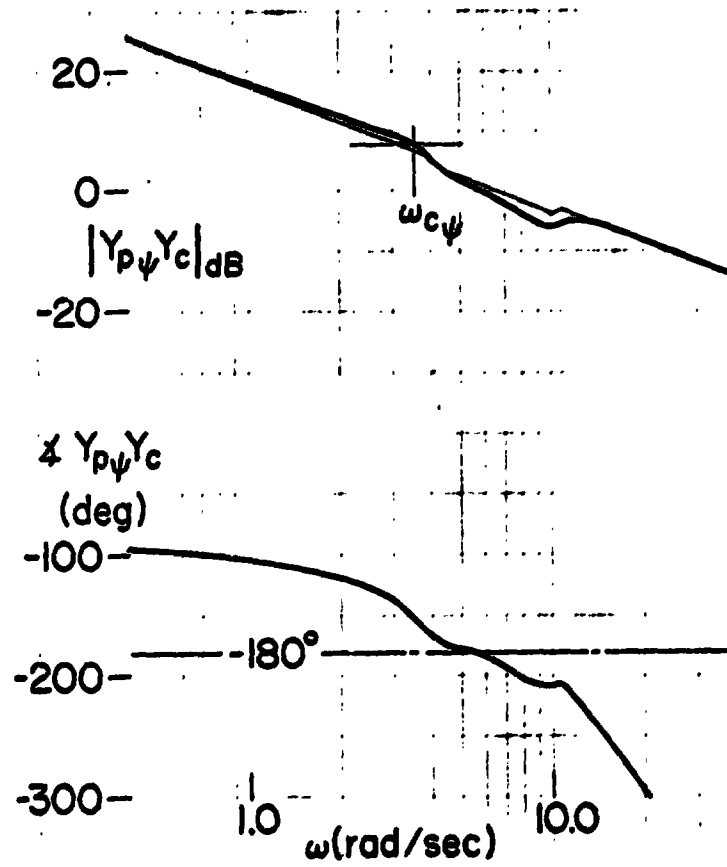
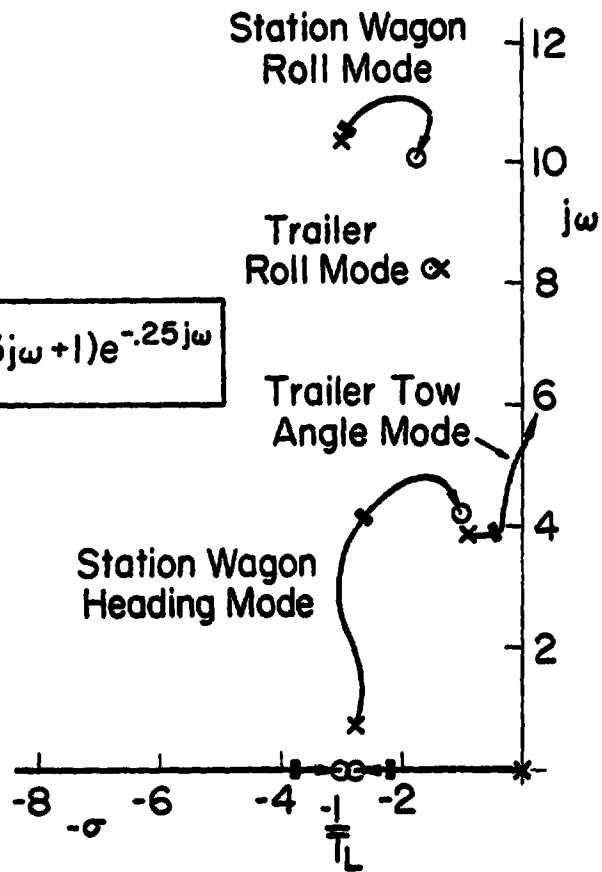

Figure 6. Driver/Vehicle Response Properties for Heading Control,  
Station Wagon Plus Trailer at 65 mph

ORIGINAL PAGE IS  
OF POOR QUALITY

P-137

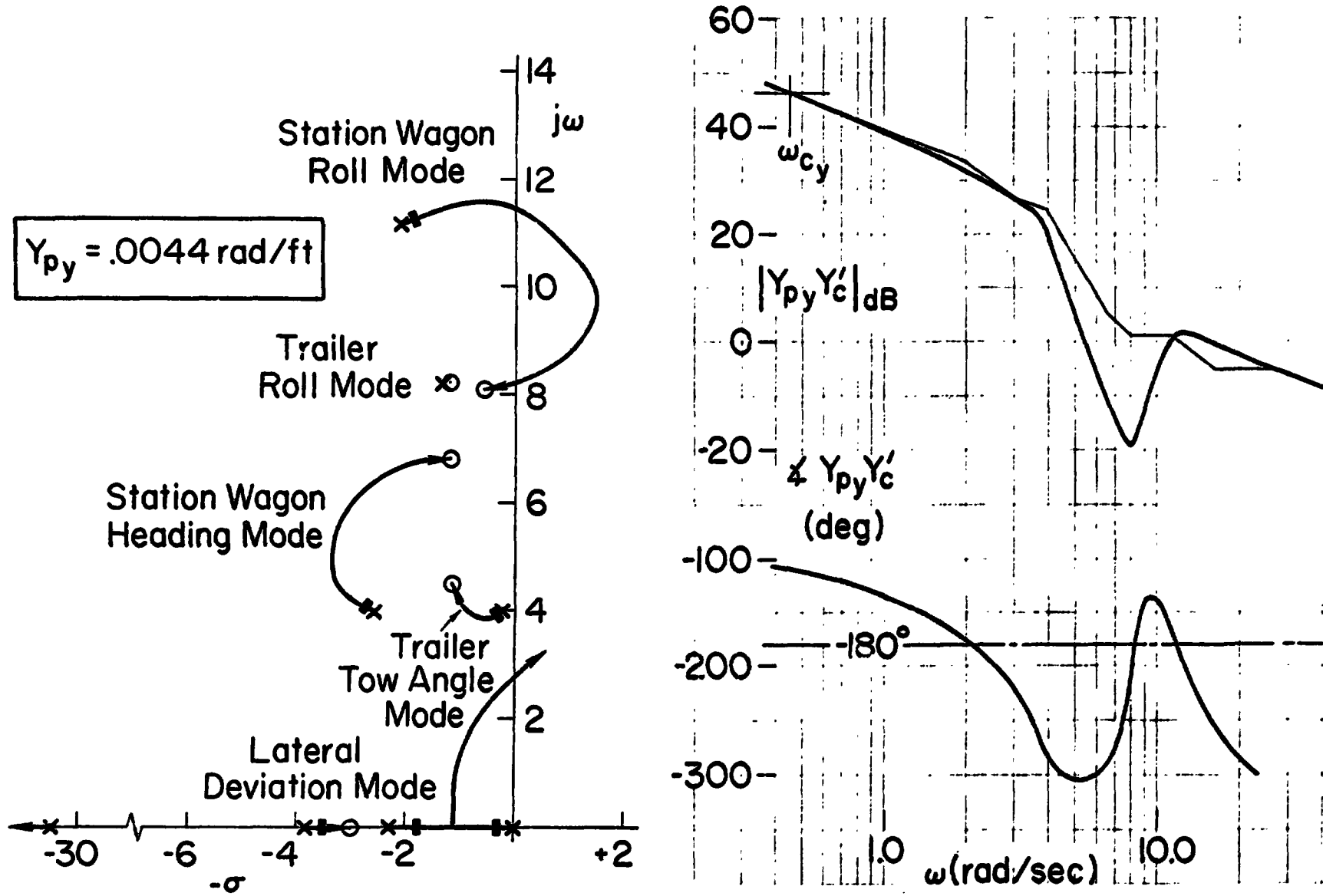

Figure 7. Driver/Vehicle Response Properties for Lateral Deviation Control, Station Wagon Plus Trailer at 65 mph

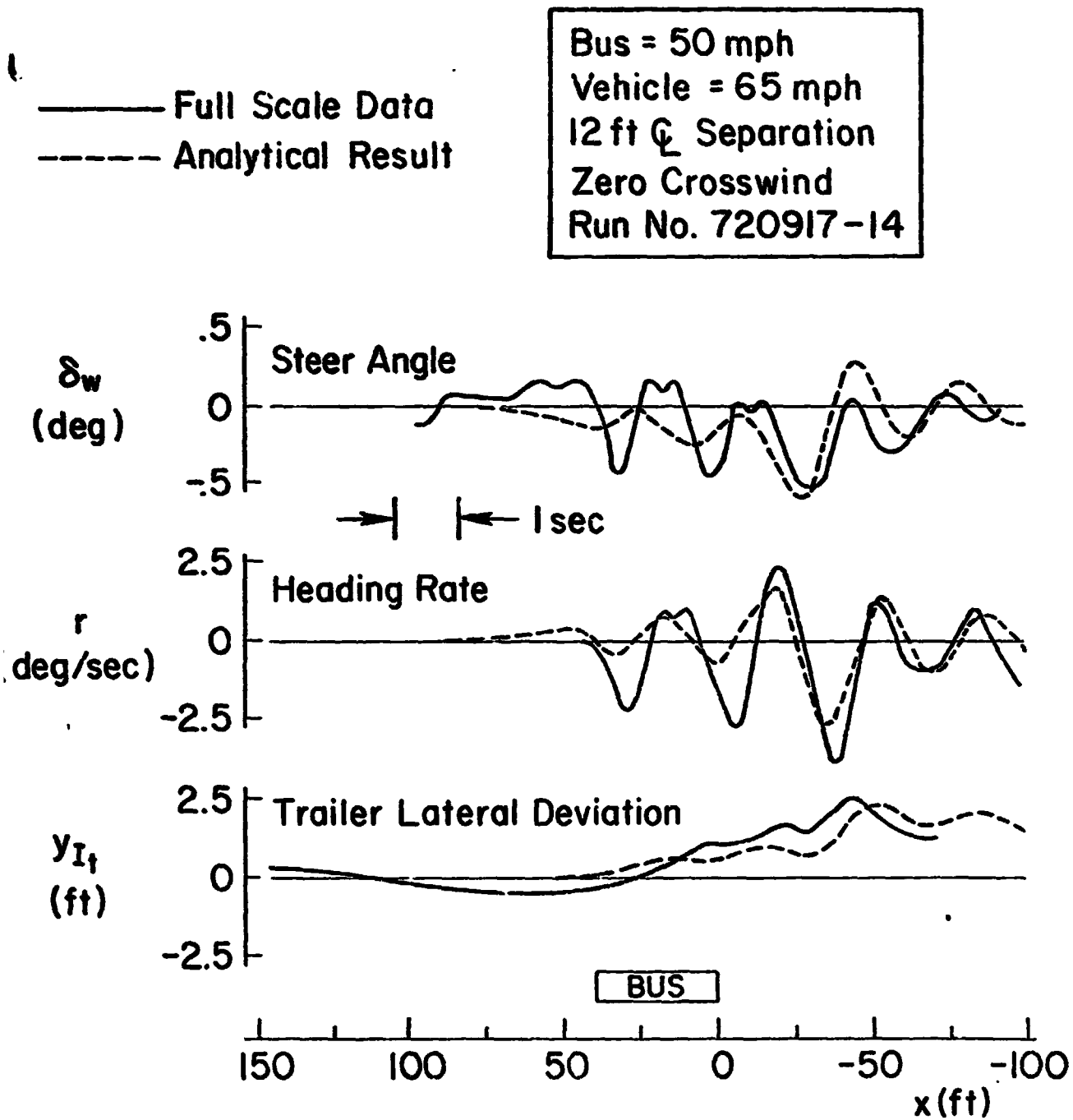

Figure 8. Comparison of Analytical and Full Scale Results, Station Wagon Plus Trailer Passing Intercity Bus

P-137

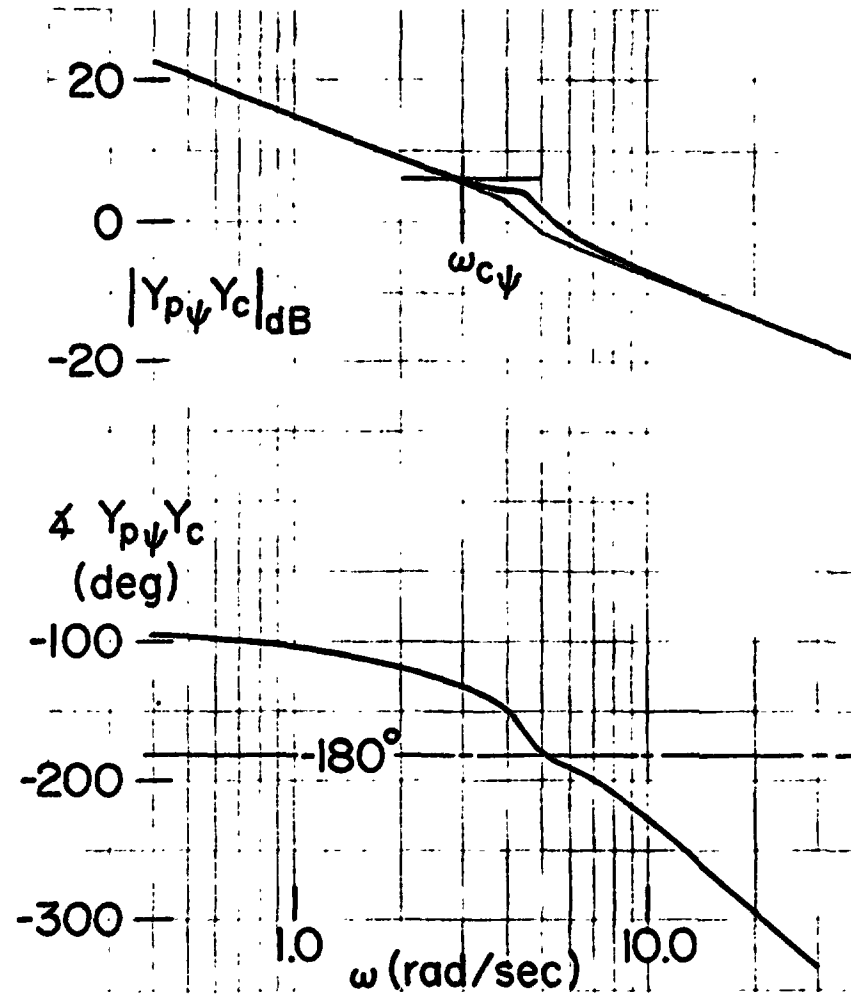
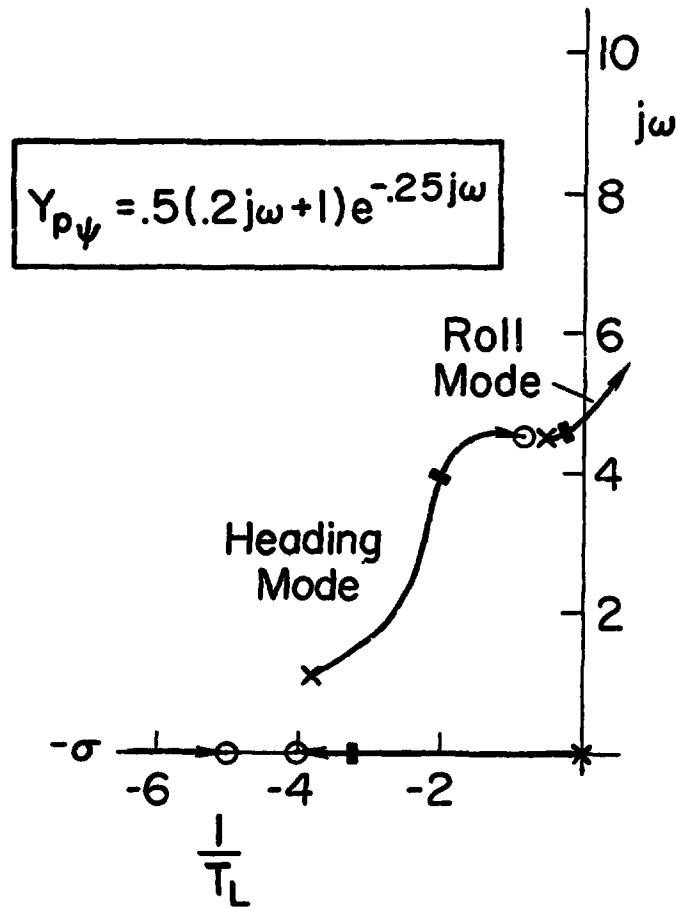

Figure 9. Driver/Vehicle Response Properties for Heading Control, Truck/Camper at 60 mph

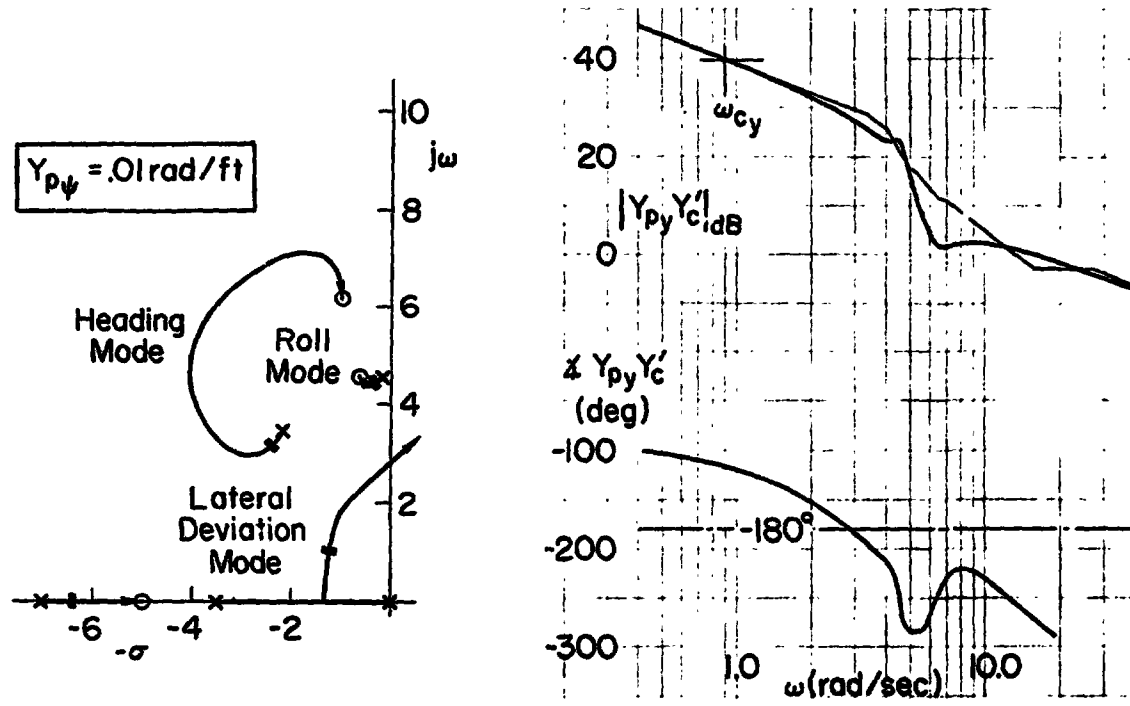

Figure 10. Driver/Vehicle Response Properties for Lateral Deviation Control, Truck/Camper at 60 mph

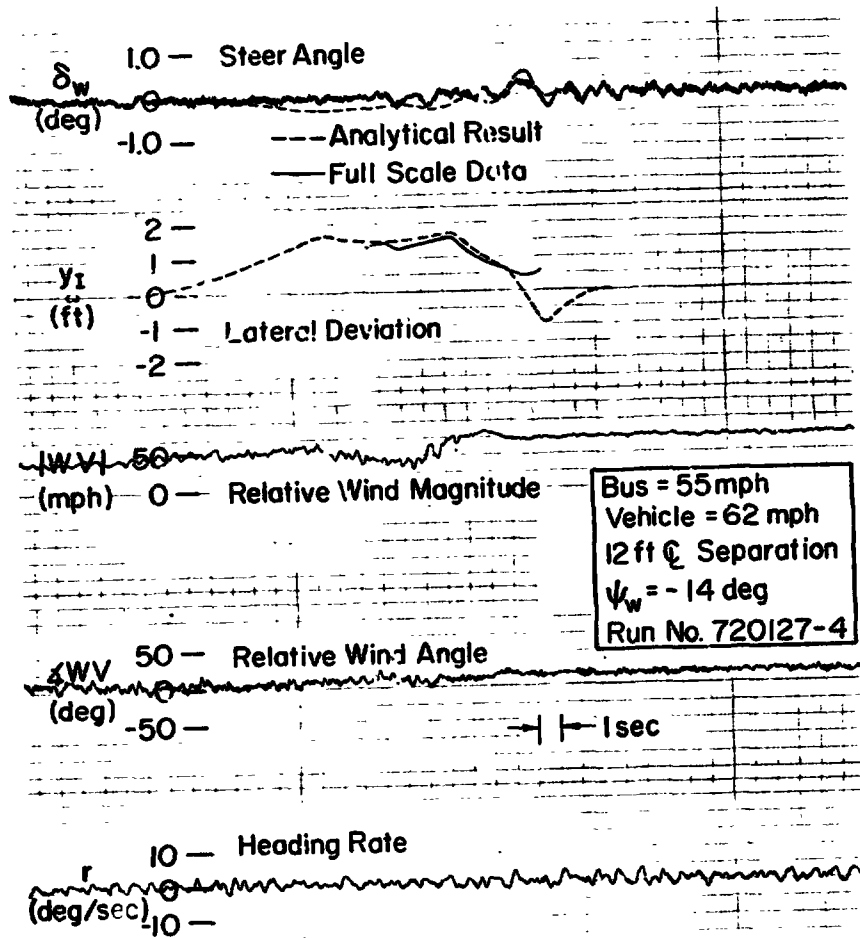

Figure 11. Comparison of Analytical and Full Scale Results, Truck/Camper Passing Intercity Bus

exhibit a lightly damped mode which tends to go unstable as a result of the heading loop closure. In the case of the truck/camper it is the roll mode which is critical. This is probably a result of the high c.g. location and large mass to roll stiffness ratio of the camper.

**Discussion** — The driver/vehicle heading loop response of the van, compact sedan, and 1972 full size sedan are all similar in form to the 1972 station wagon. The driver response properties for the other vehicles are summarized in Table 2. Details are given in Ref. 7. The lateral deviation response properties of the van, compact sedan, and 1972 sedan are similar to each other. Unlike the 1972 station wagon, their lateral deviation and heading modes are well separated; hence the driver can use a higher crossover frequency without producing undesirable qualities in the response. The outer loop closures were based on considerations discussed previously, and this was consistent with the full scale lateral deviation data. The driver/vehicle heading loop closures are seen to reflect fairly constant stability margins, in accordance with the driver model and analysis procedures. The crossover frequencies and lead equalization vary somewhat, depending on the handling dynamics of the vehicle.

The lateral deviation response properties shown in Table 2 vary considerably. The van shows low stability margins and high crossover frequencies, while the 1972 station wagon is just the opposite. As previously discussed, these variations depend on the aerodynamic and handling properties and reflect an effort on the part of the driver to achieve a desired level of performance. The performance of the several driver/vehicle systems is given in Fig. 12a for a bus disturbance in a 10 deg crosswind condition, in terms of peak lateral deviation ( $\hat{y}_1$ ). The differences in performance among the several vehicles generally follow the trend of the vehicle-alone gust susceptibility (Fig. 12b), although the variation is not as large. With two exceptions, the peak lateral deviations are all in roughly the same performance band for a given crosswind. This relative insensitivity of overall performance to changes in the control task and situation is a familiar result in the field of manual control. It reflects a constancy of skill. The performance insensitivity is usually achieved by the human controller's adjustment of his response to offset deficiencies in the vehicle dynamics (as well as other changes in task

TABLE 2  
SUMMARY OF ESTIMATED DRIVER/VEHICLE RESPONSE PROPERTIES

VEHICLE	HEADING RESPONSE					LATERAL DEVIATION RESPONSE			
	$\omega_{\psi}$ rad/sec	$T_L$ sec	$K_{D\psi}$	$\phi_m$ deg	$K_m$ dB	$\omega_{cy}$ rad/sec	$K_{py}$ rad/ft	$\phi_m$ deg	$K_m$ dB
1972 Wagon	4.3	0.14	0.79	28	3.5	0.46	0.005	75	18
1972 Wagon Plus Trailer	3.6	0.33	0.40	25	7	0.45	0.0044	80	16
Truck/Camper	3.0	0.2	0.50	48	4	0.75	0.01	65	10
Imported Van	4.2	0.2	0.71	35	4	2.3	0.03	30	5
Compact Sedan	3.6	0.33	0.45	25	5	1.3		58	17
1972 Sedan	2.8	0	0.80	60	4	0.8		60	13

b) Crosswind Gust Susceptibility, Vehicle Alone  
Figure 12. Effect of Disturbed Vehicle Properties on Estimated Performance

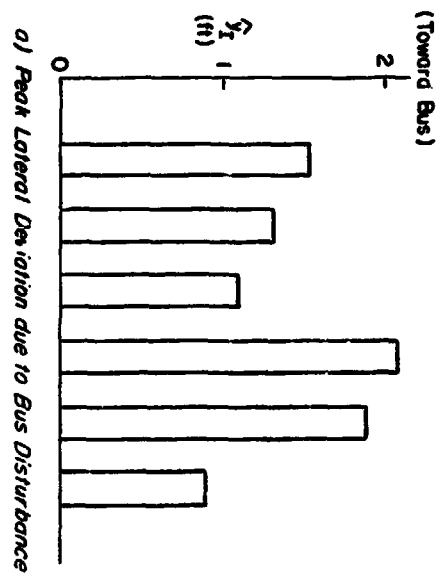
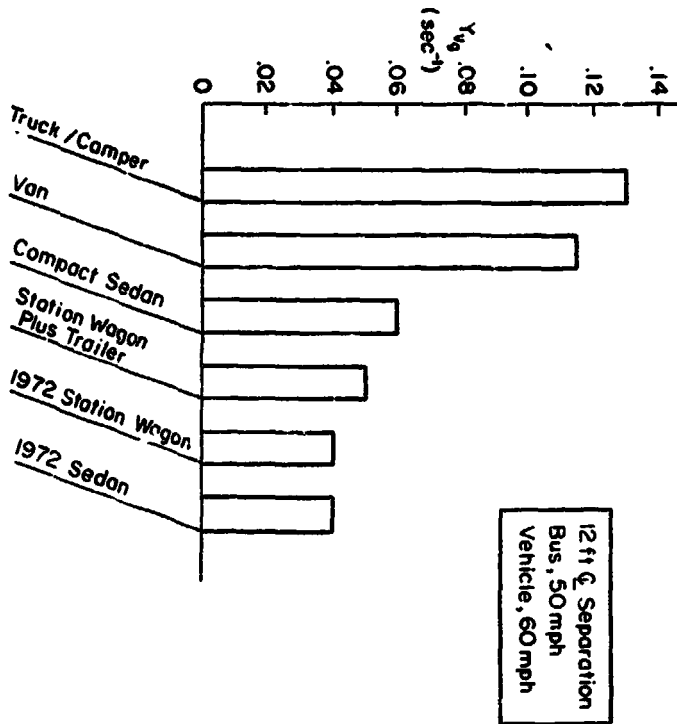

ORIGINAL PAGE IS OF POOR QUALITY

variables). The path performance (e.g., peak lateral deviation) is not the only element in the driver's "performance criterion," however, and other factors are taken into account. Hence variations in performance do occur, such as those evidenced in Fig. 12a by the 1972 station wagon and the station wagon plus trailer.

In the cases where these characteristics are reasonably nominal, the closures in Table 2 exhibit crossover frequencies about 1 rad/sec and phase margins of about 60 deg (truck/camper, compact sedan, 1972 sedan). These outer loop closures (with 60 deg phase margin) give good path mode stability and overall performance, simple response qualities with constant closed loop damping ratio across vehicles, and a relative insensitivity to changes in driver gain. The performance is proportional to driver control effort (crossover frequency). Departures from the nominal lateral deviation response properties for the remaining three vehicles can be summarized as follows:

- The 1972 station wagon estimates exhibit a somewhat lower crossover frequency and larger phase margin in the lateral deviation loop. This is due to the undesirable interaction between the lateral deviation and heading modes which results as the crossover frequency is increased.
- The large phase margin for the station wagon plus trailer also results from an undesirable interaction between the lateral deviation and trailer tow angle modes as the driver increases the outer loop crossover frequency (see Fig. 7).
- The reduced phase margin and increased crossover frequency seen in the van estimate is due to the large gust disturbance sensitivity which results in a high yawing moment. The analyses showed that aggressive closure of the lateral deviation loop tends to stabilize the heading mode which is being excited by the yaw disturbance.

The driver/vehicle characteristics in Table 2 represent nominal results which are consistent with the full scale data.

#### REFERENCES

1. Weir, David H., and D. T. McRuer, "A Theory for Driver Steering Control of Motor Vehicles," Road User Characteristics. Highway Research Record No. 247, 1968, pp. 7-28.
2. Weir, David H., and Duane T. McRuer, "Models for Steering Control of Motor Vehicles," Fourth Annual NASA-Univ. Conf. on Manual Control, U. of Mich., 21-23 Mar. 1968, NASA SP-192, pp. 155-169.
3. Weir, David H., and Duane T. McRuer, "Dynamics of Driver/Vehicle Steering Control," Automatica, Vol. 5, No. 1, Jan. 1970, pp. 87-98.
4. Weir, David H., and Charles K. Wojcik, "The Measurement of Driver Describing Functions in Simulated Steering Control Tasks," Seventh Annual Conf. on Manual Control, USC, 2-4 June 1971, NASA SP-261, pp. 209-218.
5. Weir, David H., and Duane T. McRuer, Measurement and Interpretation of Driver Steering Behavior and Performance, SAE Paper No. 750098, presented at the SAE International Automotive Engineering Congress and Exposition, Detroit, Mich., Jan. 1973.
6. McRuer, D. T., D. Graham, and E. S. Krendel, "Manual Control of Single-Loop Systems: Parts I and II," J. Franklin Institute, Vol. 238, No. 1, Jan. 1967, pp. 1-29; and Vol. 238, No. 2, Feb. 1967, pp. 145-168.
7. Weir, David H., Roger E. Hoh, Robert K. Heffley, and Gary L. Tever, An Experimental and Analytical Investigation of the Effect of Bus-Induced Aerodynamic Disturbances on Adjacent Vehicle Control and Performance, Systems Technology, Inc., Tech. Rept. 1016-1, Nov. 1972.
8. Heffley, Robert K., The Aerodynamics of Passenger Vehicles in Close Proximity to Trucks and Buses, SAE Paper No. 730255, presented at the SAE International Automotive Engineering Congress and Exposition, Detroit, Mich., Jan. 1973.