

N75 19138**A CONFORMAL HEAD-UP DISPLAY FOR THE VISUAL APPROACH**

By

J. M. Naish

Douglas Aircraft Company
McDonnell Douglas Corporation
Long Beach, California**ABSTRACT**

The degree of conformity used in matching a superimposed display to its visual background is considered in relation to the information available for vertical guidance and control during a purely visual approach. The information may be represented by individual symbols or combined in a single symbol, and the relative merits of these methods are discussed. A fully conformal display format is developed for the purpose of showing both the position and direction of the flight path, with provision for the effects of disturbances, ILS compatibility, and control needs.

The field of view needed for all conditions and phases of the visual approach with a fully conformal display is studied in relation to the limitations of conventional collimator systems. Few methods are discussed which depend on deviation of the sight line, and on windshield reflection of the uncollimated image of a simple pointer. Limited flight tests show some promise for the uncollimated method.

INTRODUCTION

In the head-up method of presenting information, the display field is superimposed on the forward view by means of a reflecting collimator. In consequence, the user has occasion to move between information fields which may or may not be similar, depending on the way the symbol format is displayed, and this may be expected to affect the control process. When the Head-Up Display (HUD) is used as a flight director, with no requirement for aligning symbols with the external world, it is sufficient if the two fields are made only partly conformal, being understood by rules which are similar but not identical. The same is not necessarily true of the visual approach because another kind of information is involved. The first purpose of the enquiry is to examine the degree of conformity needed for this flight mode.

If the information available within the aircraft during a purely visual approach is used in a fully conformal manner, the corresponding symbols are always seen in their correct relation to the external world. This condition can be expected to influence both the form and movement of symbols, and thus exert a powerful effect on the display format. It may also demand of the optical system a field larger than is required for modes in which alignment is not essential, and it is to be asked whether sufficient field can be realized with known techniques of presentation. It is desirable also to consider the effects of providing ILS compatibility, and of operating in conditions of crosswind shear and turbulence.

CONFORMITY OF DISPLAY AND BACKGROUND**GENERAL PRINCIPLES**

Conformity exists in a superimposed display, such as a head-up display, when the symbols bear a resemblance to the background against which they are seen. The resemblance may not be complete. For example, the superimposed fields may only be alike in their orientation, to the extent that a direction of movement has the same meaning in each field. Figure 1 shows a simple attitude display in which the artificial horizon always remains parallel with the horizon visible in the external world, during changes in pitch attitude and bank angle, but this condition can be obtained without using a common scale of elevation, and without a common origin for the two fields. On the other hand, the resemblance may be more complete, such that all positions and all movements have the same meanings in each field, and there is one-to-one correspondence. It is thus possible to distinguish between displays which are partly or fully conformal.

The advantage of a conformal display is in reducing workload, for the user is not required to adapt to different rules of interpretation for each of the superimposed fields. And the best advantage is expected when the fields are fully conformal. There are practical difficulties in achieving this end, however, and full conformity cannot always be justified on grounds of workload alone. A more compelling reason is to be found in the information requirements for the visual approach.

VISUAL APPROACH INFORMATION

The need for a conformal display is not particularly strong when HUD is used to present command information, which is usually independent of the position in which it is shown, and has no natural scale in the external world when the control law embodies derivatives of angular displacements. The situation is different in the purely visual approach. The natural forward view is then the source of information about the approach path, and if HUD is used to support or augment this source, the displayed information is likely to be closely related to the background.

Two kinds of information are available in an aircraft which are independent of ground sources, and which may be used in HUD to maintain an approach path in the vertical plane, where help is most needed.⁽¹⁾ First, position can be shown with respect to a given path, such as AA', Figure 2, where A is the aircraft's position, by a symbol depressed from the horizontal by a fixed angle, γ_k , which is made equal to the inclination of the given path, in true scale. The position of the symbol in relation to the touchdown zone then presents the offset from the given path, that is, TS is proportional to AA'. Second, the direction in which the aircraft is moving can be shown by a symbol depressed from the horizontal by the flight path angle, γ , again in true scale, so that the symbol shows the end point of the flight path in the ground plane, at E. Since the scale of presentation is the same as in the external world, in both cases, and since the position of each symbol is interpreted in relation to the visual background, the presentation is fully conformal and the superimposed fields are understood by the same rule.

INDIVIDUAL OR COMBINED REPRESENTATION

It has so far been assumed that individual symbols are needed to show position and direction of the flight path. But it is also possible for both kinds of information to be combined in a control law which is then applied to a single symbol, as described by Bateman.⁽²⁾ The format is simplified by this arrangement, and simplicity is generally desirable, but the individual character of contributing components is naturally lost. And the display is no longer fully conformal, although conformity is

ORIGINAL PAGE IS
OF POOR QUALITY

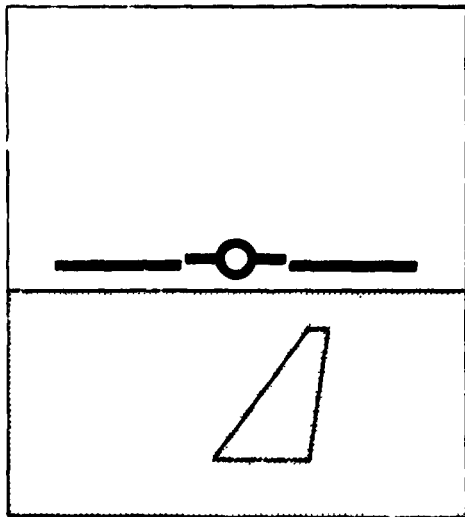

FIGURE 1. PARTLY CONFORMAL DISPLAY

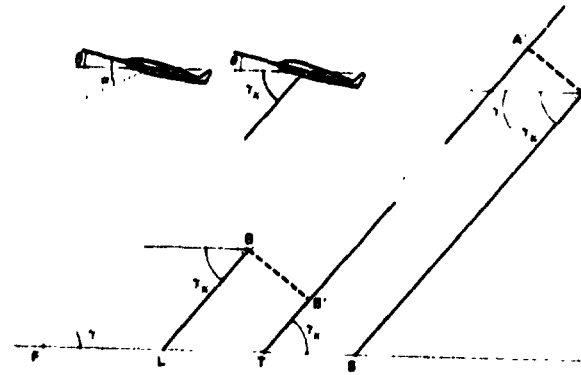
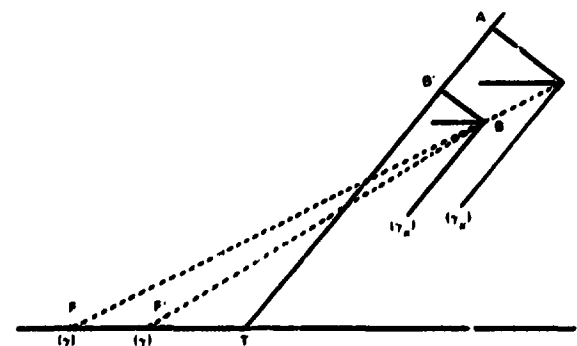

FIGURE 2. METHODS OF AIDING VISUAL APPROACH

to some extent maintained by zeroing the control law with respect to the touchdown zone. It has to be judged whether the loss of information implicit in combined representation, and the loss of conformity, are penalties which can be accepted in the interest of a simplified format.

An important feature of the situation is the complementary nature of the two classes of information each contributing to, but neither entirely sufficient in itself for the purpose of following a given path. The fixed depression symbol shows whether the aircraft is above or below the given path, which the flight path symbol does not show, and the flight path symbol shows where the present path terminates, which the fixed depression symbol only allows to be inferred, from its change of position. When the flight profile needs to be known, as in deciding when to start an approach or in deciding whether energy has to be lost or gained in order to wash out an offset, the fixed depression symbol appears to be indispensable. On the other hand, this symbol gives poor information about the rate at which the given path is joined, though this is shown directly by the flight path symbol.

When both symbols are shown they are used in conjunction in the manner shown in Figure 3. The flight path AF is chosen to reduce the offset AA' at a suitable rate, which is then adjusted by altering the flight path to BF' when the offset has been reduced to BB'. It can be seen that the positions of the two symbols, which are represented by the figures in parentheses, lie on opposite sides of the touchdown zone, T, when the operation is correctly performed, and this condition is maintained by the user. The same result would be achieved by a suitable control law applied to a single symbol backing off displacement by rate in the usual way, but without awareness of the magnitudes of the contributing components. Individual representation thus allows the same control as combined representation but a better grasp of the total situation.



Another aspect of the situation is that the two symbols are affected differently by errors, noise, and wind (1). Both symbols are subject to errors, but the flight path symbol is more sensitive in the way errors affect longitudinal touchdown dispersion. As regards noise, both symbols are subject to whatever disturbances affect their data sources, so that the flight path symbol is adversely affected if no inertial platform is available and it has to be driven by an angle of attack signal, whereas the fixed depression symbol is not significantly affected. The influence of longitudinal wind is shown by both symbols, either as a change in offset or as a change in flight path, but the situation is again complicated in the case of the flight path symbol by the nature of the data source. The fixed depression symbol is thus less influenced, or at least influenced in a less complex manner, by disturbances and errors and may with advantage be shown independently.

The question of individual versus combined representation is also affected by control considerations in the vertical plane. While it may not be desirable always to separate the effects of thrust and attitude on the path and speed of an aircraft, there are circumstances when it is advantageous to do so. It may be possible to achieve change of speed, at fixed thrust, primarily by the use of the elevator and to change the direction of the flight path, at fixed speed, primarily by using thrust. In such a case, there is good reason to associate speed control with an attitude symbol, and to link height control (through flight path direction) with a symbol related to thrust. Clearly, this is less easily done if the flight path symbol loses its identity.

Finally, this issue is affected by the desirability of compatibility with ILS procedure, for although the display is intended for the purely visual approach, there will be occasions when ILS signals are available in visual flight conditions. At such times, it will be convenient if the display continues to function in the same manner, while showing the correct relationship to the glideslope origin. This

FIGURE 3. REDUCTION OF OFFSET BY PATH CONTROL

can be achieved quite simply by adding a symbol to represent the glideslope origin and by displacing it from the fixed depression symbol by the glideslope deviation, β . Then, as shown in Figure 4, the symbol will always coincide with the glideslope origin (here assumed situated at the touchdown zone) because the aircraft's elevation is $\gamma_e + \beta$.

Operation of the display with ILS compatibility can be illustrated by the special cases shown in Figures 5 and 6. In the case when the aircraft approaches with β constant, along the path AB, Figure 5, the touchdown zone remains at the same angular distance from the artificial horizon. As range decreases, the runway appears to grow and the position of the fixed depression symbol is interpreted as showing a smaller linear offset from the beam, the constant angle β representing a smaller ground run at the enlarged scale. In the case when the approach is made with constant linear offset from the beam, along the path AB in Figure 6, the fixed depression symbol remains at the same linear distance from the touchdown zone. This corresponds to an increased angular subtense at shorter range, the fixed depression symbol appearing to move away from the touchdown zone but at the same rate as the runway appears to grow. It is not difficult to see that these cases have their analogs in night operations when the touchdown zone is illuminated, and it is clear that the part played by the fixed depression symbol in all of them is only possible if it remains an individual entity.

The issues which have been discussed allow a good case to be made for individual representation. It seems reasonable to assume that it will generally be desirable to know both position and direction of the flight path, that it will be advantageous in balancing rate against displacement to know the magnitudes involved, which may be interpreted in the context of the visual background; that noise and error effects should be eliminated as much as possible, and wind effects estimated accurately, that control will be simplified in many cases by establishing separate pitch and thrust information channels, and that ILS compatibility is desirable. In what follows, it is assumed that these factors, which operate in the fully conformal display, are sufficient to justify the loss of simplicity resulting from the use of individual symbols to represent fixed depression and flight path angles.

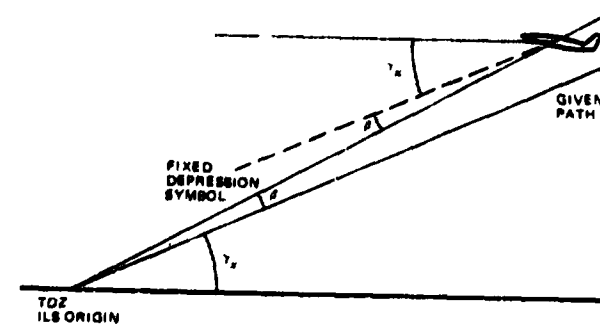

CONFORMAL DISPLAY FOR VISUAL APPROACH

BASIC FORMAT

A fully conformal display for the visual approach, with the features which have been discussed, can be developed from the basic format of Figure 7, where the visual background is shown in schematic form. It is assumed that the framework of the format is fixed with respect to the airframe, and that its visible extent is limited by a simple rectangle. All components of the display format are shown as thick lines, to indicate their visual prominence in the actual display, but these are much broader than the lines as they appear to the user. The convention is used that when a symbol is displaced from its usual position, on a long-term basis, it is drawn with a broad dotted line. Features of the visual background are shown by thin lines.

The longitudinal axis of the aircraft is represented by the circular symbol with stub wings, as in previous practice. It has a fixed position on the midline of the format and thus moves with the aircraft it represents. For special purposes it may be moved into a displaced position, when it is shown in dotted form. Flanking this symbol are the two halves of a horizontal bar, which form the artificial horizon symbol. It is displaced vertically from the aircraft symbol by the pitch attitude angle, θ , in true scale and in the appropriate sense, and thus shows the position of the true (gyro) horizon in the external world. The aircraft and horizon symbols together form the attitude display, in the usual way, but it will be noted that the middle of the horizon bar is removed to avoid interference

FIGURE 4. ILS COMPATIBILITY

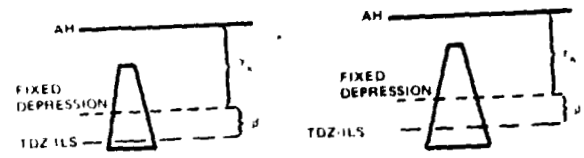
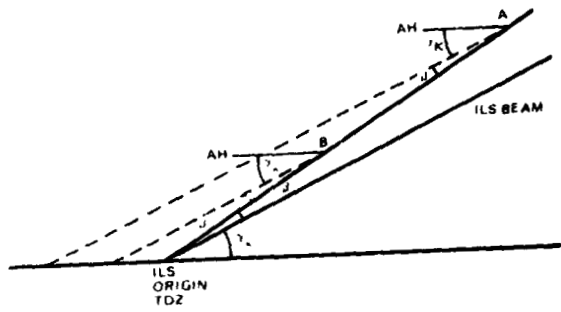

FIGURE 5. APPROACH WITH CONSTANT DEVIATION

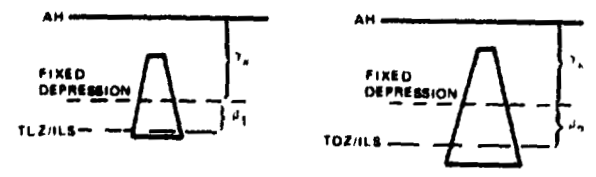
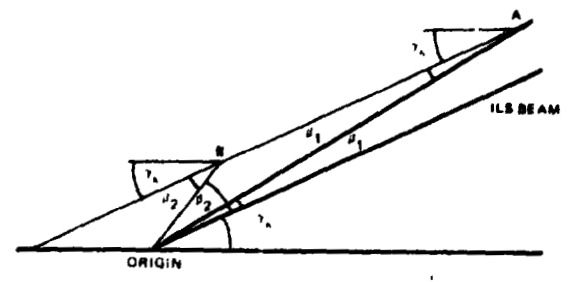

FIGURE 6. APPROACH WITH CONSTANT OFFSET

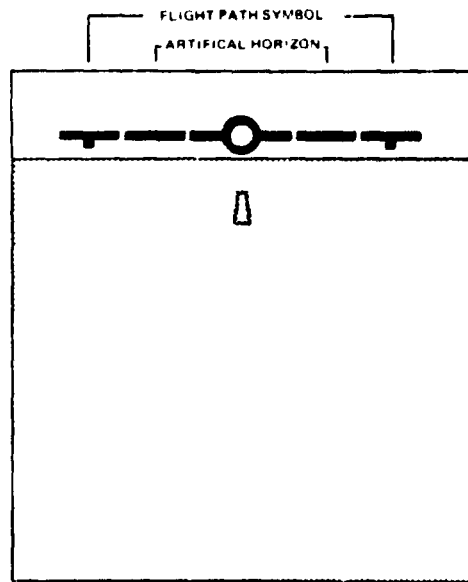

FIGURE 7 BASIC FORMAT

The artificial horizon is in turn flanked by the two halves of another bar, to which vertical bars of variable length are attached below. It is displaced from the artificial horizon by the flight path angle, in true scale, and thus shows the position of the flight path in the external world. In the approach configuration, the vertical bars are lengthened to form the letter T, suggesting, also an association between thrust and flight path direction, and therefore height. As the symbols appear in Figure 7, the aircraft is in level flight with zero pitch attitude. It will be noted that the horizon bar does not coincide with the visible horizon because of the angle of dip (and perhaps also because of effects of visibility and terrain).

APPROACH TRANSITION

Development of the format for the approach transition, or for ILS capture, is shown in Figure 8. The main difference is in the addition of the fixed depression symbol which has the same form as the horizon bar but is dotted to show long-term displacement. It is set below the artificial horizon by the desired approach path angle or by the glideslope angle, in true scale, so that $\gamma_k = 3$ degrees, say. When the desired flight path is horizontal ($\gamma_k = 0$), the fixed depression symbol is concealed by the horizon bar. The situation shown in Figure 8 corresponds to a position such as A in Figure 2 where the desired path has not yet been intercepted, and this is shown by the symbol lying short of the runway.

Another difference is the addition of an ILS datum mark, the two halves of which lie outside the flight path symbol, where they serve the minor purpose of showing coincidence with the ILS origin in perfect conditions, be they displaced from the fixed depression symbol by the angle β in true scale as previously described. This symbol does not appear in the absence of a valid ILS signal, nor is it shown in the glideslope extension. Figure 8 shows that the aircraft is in a landing configuration and that the flight path is being held level, by means of thrust. This condition lasts until reaching the desired path, or glideslope, which occurs when the fixed depression symbol is aligned with the touchdown zone. By this time the glideslope deviation is reduced to zero, and the convention is preserved of the ILS datum moving downward (toward the fixed depression symbol in this case) as the glideslope is intercepted from below. The diagram also shows a nose-up change of attitude.

FINAL APPROACH

The appearance of the display format during the final approach is shown in Figure 9. The horizon bar is moved downward in the format as the nose rises to the full approach attitude, and there is a smaller separation between the true and visible horizons as height decreases. At this time, attention needs to be transferred to the touchdown zone in the lower part of the format, so a duplicate aircraft symbol is introduced in a displaced position, in dotted form. The downward displacement is $\theta_k + \gamma_k$ in true angular scale, where θ_k is the ideal pitch attitude for the approach, so that the angle between the displaced aircraft symbol and the fixed depression symbol is given by

$$\Delta\theta = (\theta_k + \gamma_k) - (\theta + \gamma_k)$$

The two dotted symbols thus form a pitch attitude error display and are available for the control of speed. The displaced aircraft symbol is added by manual selection.

In the situation shown, the aircraft is above the glideslope since the fixed depression symbol is above the touchdown zone (represented here by a single lateral line on the runway). This displacement is being reduced by aiming the flight path at the other side of the touchdown zone. Speed is a little low since the pitch attitude error is in the nose-up sense. The ILS datum mark remains aligned with the touchdown zone.

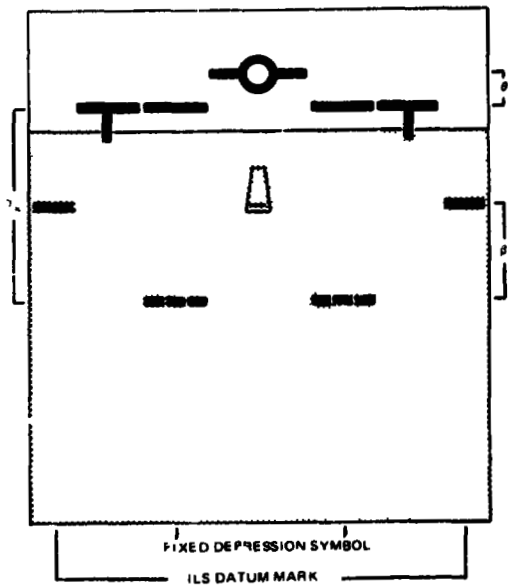

FIGURE 8. APPROACH TRANSITION

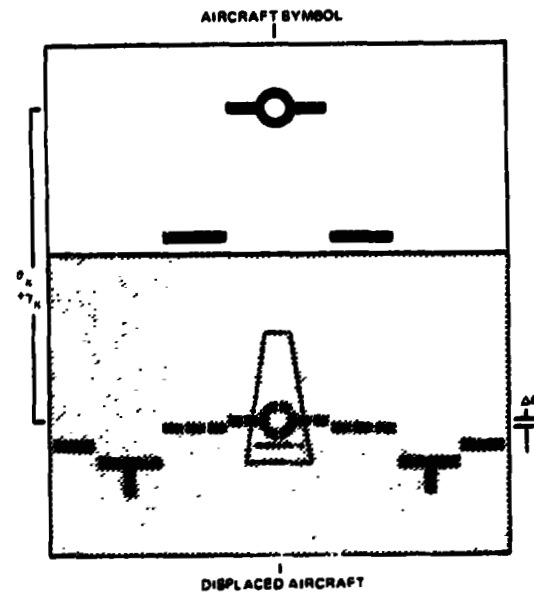

FIGURE 9. FINAL APPROACH

FIELD OF VIEW

EFFECT OF FULL CONFORMITY

Fully conformal development of HUD has an important effect on the field of view of the optical system. As the discussion has shown, it is necessary in this type of presentation for symbols to have a range of angular position. Thus, fixed depression, flight path, and ILS datum symbols need to be seen in the vicinity of the touchdown zone, which tends to move further away from, and below the longitudinal aircraft axis as the approach proceeds. For an optical system fixed in the airframe, the field of view, ω , must be of sufficient vertical extent to accommodate pitch attitude and fixed depression angles, as in Figure 9, so that

$$\omega \geq \theta_k + \gamma_k$$

This condition can be met in shallow approaches with only slightly nose-up attitudes, but is easily violated in other circumstances. For example, a 6-degree approach in a 4-degree nose-up attitude requires more than the 9-degree instantaneous field provided by a 4-inch aperture collimator when it is installed at a viewing distance of 25 inches, especially if room has to be found for peripheral symbols and allowance made for disturbed conditions.

The lateral extent of the field may need to be even greater, for although the display is only intended for vertical guidance, setting errors in the vertical plane will be smaller if the symbols are kept from moving to either side of the runway, which means accommodating the full range of drift angles. The format may thus need to be moved laterally about 30 degrees, and this cannot be achieved by standard techniques except through changing the eye position. The amount of head movement needed for this purpose, at a viewing distance of 25 inches, is 5-1/4 inches in each direction (allowing for an interpupillary distance of 2-1/2 inches) and this is unlikely to be acceptable.

It would be possible to enlarge the field by reducing the viewing distance. But experience shows that 25 inches is about the smallest value acceptable, in operating conditions, when using the present type of reflecting collimator in a typical commercial jet transport. The alternative is to increase the aperture of the optical system, thus increasing the instantaneous field and avoiding the need for head movement. The likelihood of success then depends on being able to install the larger, heavier system.

INSTALLATION STUDIES

If the collimator aperture is increased to 8 inches, the length of the collimator barrel becomes about 17 inches, and the weight about 65 pounds. Using a space model of these dimensions, installation studies have been made for the cockpit of a large commercial jet transport, with the results shown in Figures 10, 11, and 12. In the arrangement of Figure 10, which is seen from eye datum, the collimator is placed outboard and to the side, at the first officer's station, and the reflector is mounted separately on the glareshield. In this case, the instantaneous monocular field is 21 degrees. Unfortunately, the face clearance is reduced by the reflector plate, which is rather large and overhangs the glareshield by some 4 inches. Also, there is interference with the pilot's right shoulder and loss of downward view on this side.

Another arrangement is with the collimator mounted overhead, as shown in Figure 11 for a viewpoint behind the first officer's seat. There is little significant change in this case, the field is reduced slightly, to 20 degrees, the reflector plate again protrudes by 4 inches, while there is a loss

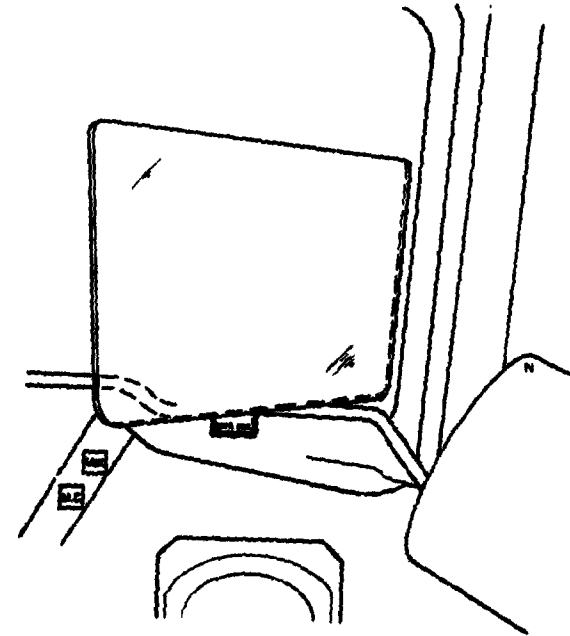

FIGURE 10. SIDE INSTALLATION OF LARGE COLLIMATOR

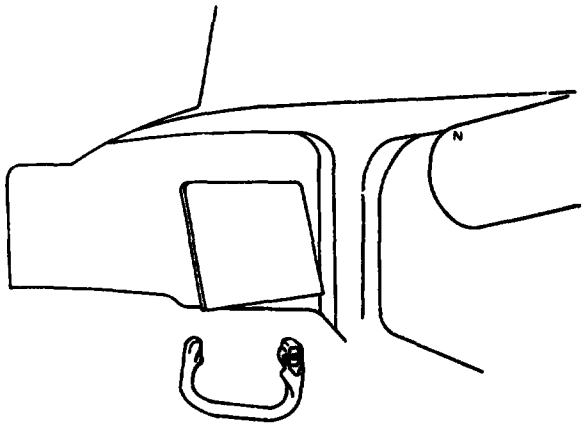

FIGURE 11. OVERHEAD INSTALLATION

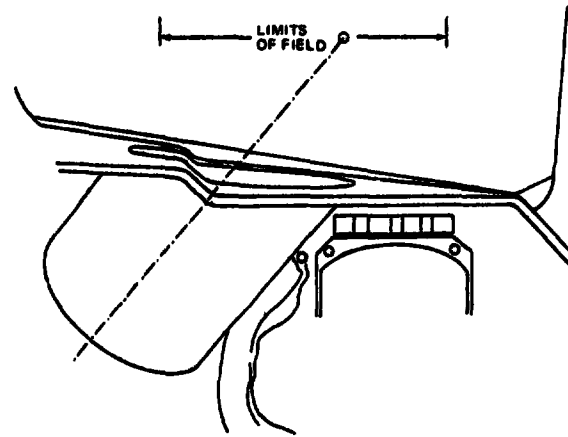

FIGURE 12. GLARESHIELD INSTALLATION

of head clearance and a restricted upward view. On the other hand, there is now less chance of sunlight falling directly into the collimator.

These arrangements are scarcely satisfactory for production purposes, and since there is insufficient space for the conventional type of gunsight mounting, it does not appear possible to install such large equipment unless the windshield itself is used as the reflector. The barrel is then mounted in the glareshield, as shown in Figure 12, where the view point is eye datum at the first officer's station. Head and face clearances are not affected in this case, nor is the external view reduced, but these advantages are achieved at the expense of panel space. And there is now interference with wheel and hands, sufficient to require modification of the control column. Moreover, the instantaneous field is no more than 14 degrees, and is centered to the left of the forward sight line, as shown by the small circle at the top of the (chain dotted) collimator axis, which is to the left of the panel instrument. Unfortunately, there is no flexibility in locating the collimator axis, and this has to be accepted with other disadvantages of the windshield as a reflector, which may arise from effects of bending, heating, lack of reflectivity, and multiple reflections. Of these, the latter may well prove to be the most serious because of low tolerances on wedge angle, typically, a wedge angle of 7 minutes of arc leads to displacement of the secondary image by about 7 times the width of line used in drawing the display symbols. For these reasons, windshield reflection does not offer much promise as an installation method for the type of cockpit considered, and there seems little hope of enlarging the field of view by the techniques so far described.

ALTERNATE METHODS

The problem of enlarging the optical field can be approached by different methods. A simple technique, which is admissible when plenty of space is available, consists in moving the entire optical system to a new position and adjusting the axis to pass through eye datum. It is then unnecessary to use a large collimator. However, the swept volume is bound to include a large part of the space between eye datum and the windshield. One way out of this difficulty may be to devise a scheme in which it is only necessary to move the reflector.

Another method is by optical displacement of the external sight line, as shown in Figure 13. A collimator, c, is mounted below the glareshield, g, and the display is seen in the reflector, r, in a conventional manner. But the sight line is turned from the usual direction, ss', to the direction, d, by means of the prism, p. The deviation of the sight line is made equal to the drift angle, so that the view centered on the flight path is shown centered on the longitudinal axis of the aircraft. In this way, moderately sized equipment can be used to deal with quite large field angles, but at the expense of a discontinuity in the external field. Clearly, this method could only be used after careful study of the disorientation potential.

Finally, it is possible to avoid a large part of the problem by abandoning collimation, using an out-of-focus presentation in the line of sight. This method appears suitable when the displayed information is very simple, so that it can be understood without detailed inspection, and it is well known that an open gunsight can be used with some accuracy. Clearly, a major advantage of HUD is sacrificed, for there is no longer any protection against effects of shortsightedness induced by an empty visual field, but this is acceptable for the visual approach.

Equipment previously used to explore this method is indicated in Figure 14. It consists of a simple link mechanism, ABCDF, which is used to keep crossbars mounted at F and C in line with eye datum, E. This equipment allows a direction in the external field to be maintained if the link mechanism is altered to compensate for aircraft movements. Unfortunately, it is difficult to mount in the space above the glareshield if the windshield is steeply inclined.

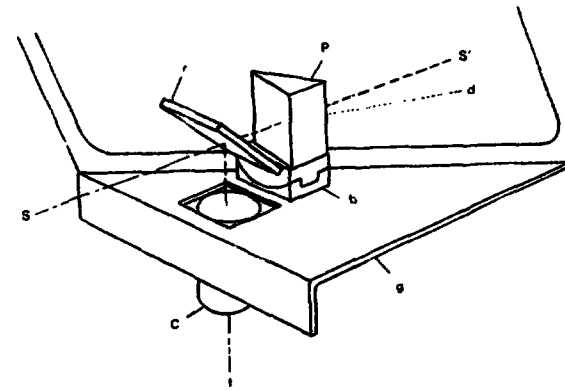

FIGURE 13. DEVIATION OF SIGHT LINE

A later development is shown in Figure 15. In this case, a single crossbar of arbitrary length is designed to be moved in the plane of the glareshield by an elementary lead screw drive. It is illuminated by ambient light so that its image may be seen by reflection in the windshield. The orientation of the lead screw is arranged to be such that the image of the bar moves up and down in the external field, in a manner representing changes in angle of attack, attitude, or related quantities. With this equipment, it is necessary to define the viewing position, and this has to be done by independent means.

The cockpit arrangement in a DC-9 is shown in Figure 16, where the captain's windshield is seen from eye datum. The baseplate of the experimental equipment is attached to the upper surface of the glareshield and cannot be seen because it is end-on to the viewer, but the crossbar, which is painted white, is evident at the lower edge of the windshield. The primary image of the crossbar appears as a white line running across the middle of the windshield. At some distance above is a secondary image of less brightness. The primary and secondary images are accompanied by much fainter images in close attendance. The images all lie in a horizontal plane but appear to converge slightly because they are closer than infinity.

Test flights were made with the equipment by two experimental test pilots, with the following results. About twelve approaches were carried out, mostly in fine weather but occasionally in poor external lighting conditions. The equipment was not driven by an input signal but used in a passive condition, simply to evaluate the uncollimated crossbar image as a means for conveying information in conditions of an active external scan. It was found somewhat distracting not to have the image at infinity and it was felt that the initial reaction of other users would be unfavorable. Multiple images, though annoying, were not unduly bothersome. It was convenient that the brightest image was also the lowest, suggesting an association with the nearer end of the runway, and leaving no doubt about which image to use. If desired, the two brightest images could be used as a bracket. The apparent inclination of the lines did not trouble the user. The primary image was visible under a range of lighting conditions, with the bar painted gloss white, but local illumination would naturally be needed by night. The travel of the bar was adequate, when moved up and down by hand, but the image needed to extend further toward the centerline of the aircraft. It was felt that the device had some merit and was worth developing as a flight aid, using an angle of attack, or a fixed depression drive.

CONCLUSION

A fully conformal display is desirable for head-up presentation on the general grounds of reduced workload, because it enables geometrical relationships in the superimposed fields to be understood by the same method of interpretation. It is more particularly desirable in the purely visual approach, for which two kinds of information available within the resources of an aircraft need to be understood in the context of the external visual world, each being represented by its own symbol. A simpler format results from a combined representation, but this precludes knowledge of the flight profile and of the rate used in reducing an offset. Also, individual representation is preferable for the elimination of noise and error effects, for the estimation of wind effects, for linking stick and throttle with individual elements of the display, and for the realization of ISL compatibility.

A fully conformal display can be developed from an attitude display by adding symbols showing fixed depression and flight path angles in true scale, which give information about the position and direction of the flight path. Another symbol can be added to show the position of the ILS glideslope origin, and a simple modification allows attitude to be used in controlling speed.

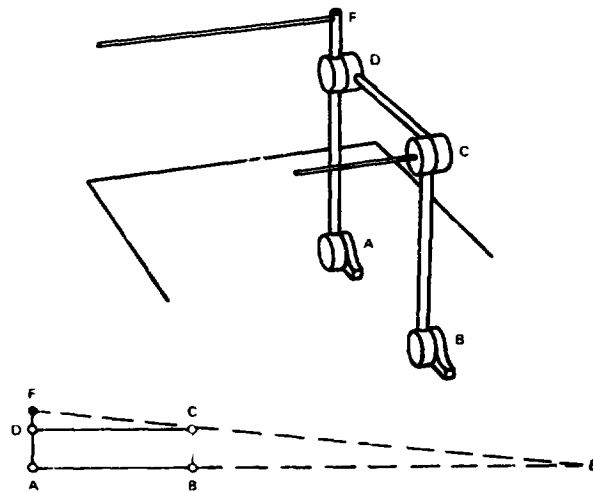

FIGURE 14. OPEN SIGHT LINK MECHANISM

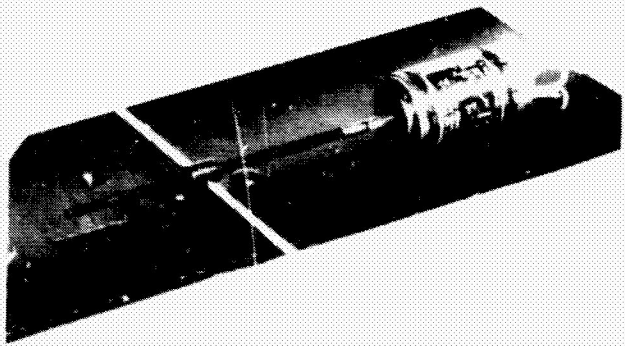

FIGURE 15. REFLECTED CROSSBAR MECHANISM

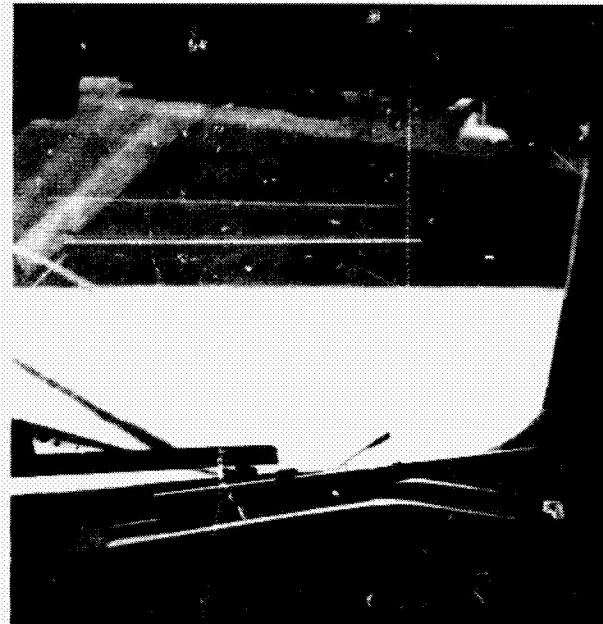

FIGURE 16. COCKPIT PRESENTATION OF REFLECTED CROSSBAR

But difficulties are met in trying to provide an adequate field of view, which is needed because of large relative movements of the center of interest in the external world during the course of a visual approach. New developments are needed to enlarge the field of the present type of display system, as may be used in commercial jet transports, since viewing distance cannot be decreased without loss of face clearance, and aperture cannot readily be increased without introducing other clearance problems and reducing the external view. Some of these difficulties are alleviated by the method of windshield reflection, but new problems arise, especially the problem of multiple images, and the field of view is only moderately large.

One possibility is that the external sight line may be deviated by means of a prism. This method allows the field to be enlarged while using quite small equipment, but a discontinuity is introduced in the external field, the seriousness of which is hard to assess. Another possibility is that collimation may be dispensed with by using some form of open sight, a method which is admissible when presenting simple information in visual approach conditions. If space is available, a mechanical linkage can be mounted above the glare shield and used to define an external direction by the alignment of pointers. An easier way is to move a pointer in the plane of the glare shield and use the ambient illumination to form an image by reflection in the windshield, in which case the head position needs to be defined. Flight tests of the latter method showed that adequate field could be obtained with a pointer of sufficient length, and that the method was worth developing as a simple flight aid despite obvious limitations of image quality.

The investigation shows that fully conformal head-up presentation, though suitable for guidance and control in the vertical plane during a visual approach, and though capable of realization in a format of symbols, depends for its success on the further development of techniques for enlarging the field of view.

REFERENCES

1. Naish, J. M., "Head-Up Display for the Visual Approach," 8th Annual NASA-University Conference on Manual Control, University of Michigan, Ann Arbor, Michigan, May 1972; Douglas Paper 6033.
2. Bateman, C. D., "The Single Task. A Flyability Improvement to the Visual Landing Aid," United Control, Redmond, Washington, January 1971.

DOUGLAS AIRCRAFT COMPANY
3825 Latham Street, Long Beach, California 90801 (213) 592-5511
ANDERSON & BONNER
CORPORATION
PRINTED IN USA MAY 1973