

**LIFE SCIENCES
SHUTTLE LABORATORY
LS-09-S
SORTIE PAYLOAD
Volume II of VI**

Prepared for

**National Aeronautics and Space Administration
Marshall Space Flight Center
Huntsville, Alabama**

by

**Grumman Aerospace Corporation
Bethpage, New York 11714**

Contract No. NAS 8-31102

**Part of Mission No. 14
March 1974 Traffic Model**

OPERATIONS PLANNING SIMULATION

MODEL EXTENSION STUDY

FINAL REPORT

REPORT NO. SU OPS-RP-75-0001

PREPARED FOR
THE GEORGE C. MARSHALL SPACE FLIGHT CENTER
HUNTSVILLE, ALABAMA

CONTRACT NUMBER
NAS8-31102

PREPARED BY
GRUMMAN AEROSPACE CORPORATION
PRODUCT SUPPORT DEPARTMENT
BETHPAGE, NEW YORK

DATE: 1 February 1975

D. A. Marks, Study Manager
R. E. Gendiellee
T. M. Kelly
M. A. Giovannello

OPERATIONS PLANNING SIMULATION MODEL STUDY
(Contract NAS8-31102)

This is the final report of Contract NAS8-31102 and is submitted by the Grumman Aerospace Corporation, Bethpage, N. Y., in accordance with the terms and conditions of the contract.

The final report is packaged in six (6) volumes, entitled:

- Volume I - Long Duration Exposure Facility (LDEF), Payload No. ST-01-A
- Volume II - Life Sciences Shuttle Laboratory, Payload No. LS-09-S
Biomedical Experiments Scientific Satellite,
Payload No. LS-02-A
- Volume III - Dedicated Solar Sortie Mission (DSSM), Payload No. SO-01-S
- Volume IV - Magnetic Spectrometer, Payload No. HE-15-S
- Volume V - Mariner Jupiter Orbiter (MJO), Payload No. PL-12-A
- Volume VI - Expanded Functional Flows and Descriptions

I Study Objective

The objective of the Study was to evaluate the Launch Site Facility Requirements Data Sheets for selected Automated and Sortie Payloads.

The Study achieved the objective by:

- o Expanding the NASA launch site Level O functional flow activities to a depth required to identify payload launch site facility and support requirements (Volume VI contains the generic functional flow activities for Automated and Sortie payloads).
- o Conducting analyses of the payload definitions contained in the Level B Data issued by SSPD from the launch site ground processing viewpoint.
- o Processing the payloads through the expanded functional flow activities, and identifying the launch site facility and support requirements.
- o Comparing the generated requirements with those contained in the Launch Site Facility Requirements Data Sheets.

II Study Recommendations

Recommendations from the Study include:

- o Expansion and revision as appropriate of the Level B Data (SSPD) to define in detail the payload ground requirements, based upon the launch site functional flow activities, as well as performing Level II (not Level III) integration at the launch site.

Specific data sheets involved are:

- On-Orbit Checkout/Monitor/Control Equipment (Data Sheet No. A-9 and A-12)
- SKETCHES (Data Sheets No. A-10, S-5, and S-6), with emphasis on the configurations at launch site arrival and installed in Orbiter cargo bay.
- Interface Diagrams (Data Sheet No. S-7) showing the interfaces for monitoring and checkout during launch site ground processing.
- Data and Communications Checkout and Deployment Support/On-orbit Operations Support (Data Sheets No. A-14, A-15, S-19, and S-20).
- Launch/Landing Support Requirements (Data Sheets No. A-18 and S-22).
- Ground Facility Requirements (Data Sheets No. A-19 and S-23).
- Ground Environmental Limits (Data Sheets No. A-20 and S-24).

SUMMARY (Continued)

II Study Recommendations (Cont'd.)

- o Definition and descriptions to Level 4 or 5 of the launch site functional flow activities.
- o Investigation of payload ground requirements at the launch site which are identified as cost drivers for ground processing in this report.

III Future Investigative Areas

Cost effective processing of payloads at the launch site requires further studies and analyses. One area which would provide fruitful results is the generation of detail scenarios of representative payloads by disciplines for Payload Working Groups approval/modification. These detail scenarios would include the ground processing for:

- o Block 1.0 Activities - Payload Pre-mission Processing
- o Block 2.0 Activities - Orbiter/Payload Integration and Checkout
- o Block 3.0 Activities - Pre-launch and Launch Operations
- o Block 4.0 Activities - Recovery Operations
- o Block 5.0 Activities - Post Mission Processing

Descriptions and required outline drawings would be provided to define in detail such ground functions and configurations as:

- o Payload and associated ground control and support equipment launch site arrival configurations, transportation and environmental modes, and arrival servicing and inspection/monitoring requirements.
- o Payload calibration
- o Monitoring
- o Checkout
- o Servicing
- o Intra-launch site transportation

The Grumman Aerospace Corporation would be pleased to assist the NASA/MSFC in performing additional studies and analyses to implement effective payload ground processing.

MISSION #14 - LIFE SCIENCES SHUTTLE LABORATORY (LS-09-S)

SORTIE PAYLOAD

BIOMEDICAL EXPERIMENTS SCIENTIFIC SATELLITE (LS-02-A)

AUTOMATED PAYLOAD

FUNCTIONAL FLOW DESCRIPTIONS AND PAYLOAD

REQUIREMENTS FOR GROUND AND LAUNCH SUPPORT FACILITIES

Block 1.0 Activities - Payload Pre-mission Processing

One of the baselines of the Study is the Definition and Requirements Data Level B. The June 1974 issue of Level B Data for the Biomedical Experiment Scientific Satellite (BESS) - LS-02-A - indicates experiment characteristics are in major revision, and revised Level B data sheets will be prepared as soon as possible. Thus, the BESS is not incorporated in the Study at this time.

A review of the Level B data (dated June 1974) for the Life Sciences Shuttle Laboratory (LSSL) and the "Spacelab, Preliminary Technical Description for use in Payload Accommodation Studies" (June 1974) document reveals inconsistent data. For example, the LSSL Level B data indicates a laboratory of some 25 feet long, whereas the Spacelab document indicates a combined core and experiment segments length of about 17.6 feet with a portion of the core segment used for its subsystems (EPDS, CDMS, and ECS). For the purposes of this Study, the assumption is made that the LSSL Level B data will fit into the Spacelab combined core and experiment segments.

The LSSL Level B data addresses the Medical Emphasis Mission which defines the Life Sciences Shuttle Laboratory for the ground and launch support facilities Study.

In keeping with the ground rules that all Spacelab elements except pallets are processed by launch site personnel, the LSSL experiments in the form of standard racks/consoles (6½ feet high, 2 feet wide, and 2 feet deep) arrive at the launch site, and are installed in the core and experiment segments.

An overview of processing the LSSL racks/consoles follows:

- o Individual racks/consoles interfaces are verified.
- o Racks/consoles are mounted on the Cargo airplane-type floor segments of the Spacelab core and experiment segments, and interfaces between racks/consoles mated.
- o Interfaces of the grouped racks/consoles are verified.
- o Grouped racks/consoles are loaded into the Spacelab core and experiment segments, using the rack assembly loading/unloading fixture described in the Spacelab Preliminary Technical Description document.
- o Interfaces between racks/consoles and Spacelab core and experiment segments are mated and verified.

ORIGINAL PAGE IS
OF POOR QUALITY

Block 1.1 Configure Experiment Section Pressure Shells

Block 1.2 Support Section/Experiment Section Pressure Shell Verification

Block 1.3 Liaison Pallet Verification

The above blocks are not applicable to the LSSL experiments.

Block 1.4 Receive and Inspect Racks/Rack Sets/Floor Assemblies and
Special Experiment Sections

Block 1.4.1 Racks/Rack Sets/Floor Assemblies and Special Experiment Sections
(hereafter referred to as Experiment Equipment) arrive at Launch
Site via Commercial Truck

The LSSL experiment equipment is generally either rack mounted in standard racks or consists of consoles which are $6\frac{1}{2}$ feet high, 2 feet wide, and 2 feet deep. There are a total of eleven (11) standard racks/consoles. In addition, the experiment equipment contains an Internal Centrifuge (12.7 feet diameter, 2.7 feet wide) which mounts at the aft end of the Spacelab experiment segment.

Figure 1-1 shows a typical rack, and an outline of the centrifuge. Non-operating environmental limits are TBD (Data Sheet #S-9, dated May 1974), however, it is assumed that in normal shipping containers, the Experiment Equipment will not be damaged by truck transportation which is selected on basis of economy.

ORIGINAL PAGE IS
OF POOR QUALITY

Life Sciences Shuttle Laboratory (LSSL) -
MEDICAL EMPHASIS MISSION

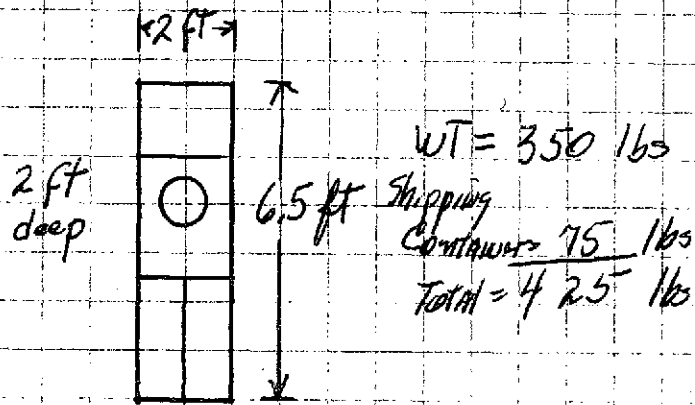

Typical Rack/console
(TOTAL 11)

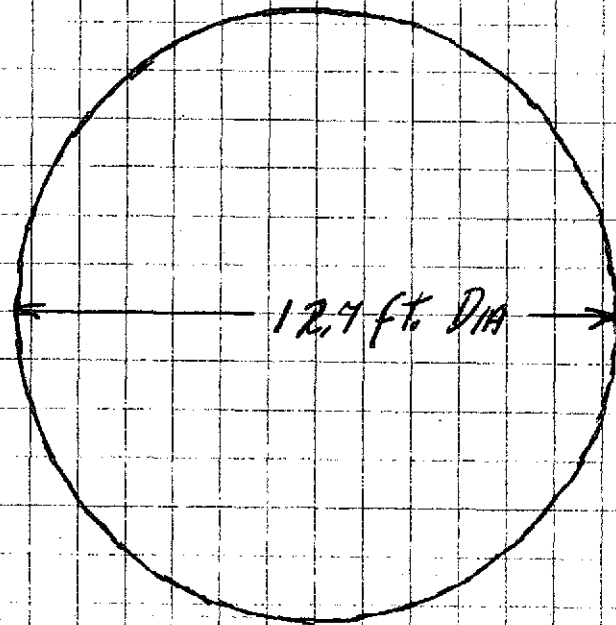

Internal Centrifuge

WT = 700 lbs
Shipping Container = 300 lbs
Total = 1,000 lbs

ORIGINAL PAGE IS
OF POOR QUALITY

Figure 1-1

Block 1.4.2 Unload Experiment Equipment from Commercial Carrier and Place
in Temporary Storage

The equipment racks/consols are unloaded from commercial trucks, placed in closed-body trucks, moved to protected temporary storage. Due to its size and weight, the centrifuge (14 feet in diameter, 4 feet deep; weight - 1,000 lbs.) requires special attention; the transport of the equipment racks/consols is routine.

Ground and Launch Support Facility Requirements

Facility Requirements

- o Temporary protected storage area (hangar type satisfactory).
 - 54 feet long, 14 feet wide, 8 feet high for racks/consols.
 - 16 feet long, 6 feet wide, 16 feet high for centrifuge.

Support Requirements

- o Mobile crane (2,000 lbs. capacity)
- o Fork lift trucks
- o 2½ ton, closed body truck
- o Centrifuge shipping container hoisting sling
- o Operators for crane, 2½ ton truck, fork lift truck
- o Riggers
- o Inventory management.

Block 1.4.3 Transport Experiment Equipment from Temporary Storage
to Receiving Area of PPF

The equipment racks/consolas and centrifuge are removed from temporary storage and transported to the receiving area of the PPF to meet the requirements of the Orbiter launch schedule.

In addition to following the overview described in Block 1.0 above, the functional flow which follows generates an even distribution of work tasks for unpacking, individual racks/consolas interface verification, and similar functional operations in the PPF. The unpacking operation is accomplished in series, the interface verification in parallel, and the installation into the Spacelab core and experiment segments in series.

Ground and Launch Support Facility Requirements

Facility Requirements

- o Receiving area of PPF.
 - 38 feet long, 14 feet wide, 8 feet high (for 4 racks/consolas).
(also suitable for centrifuge)
- o Overhead or mobile crane at PPF (2,000 lbs. capacity)

Support Requirements

- o Mobile crane at storage area (2,000 lbs. capacity)
- o Fork lift trucks at storage area and PPF
- o 2½ tons, closed body truck
- o Operators for crane, fork lift truck, and 2½ ton truck
- o Riggers
- o Inventory management.

Block 1.4.4 Unpack Experiment Equipment and Place on Movable Dolly

The racks/consolas are uncrated and placed on movable dollies.

Due to its size and weight, the centrifuge requires a special holding fixture, preferably equipped with wheels so that it can be towed. It is anticipated that this fixture is required at the Central Integration Site (CIS), and would be a portion of the LSSL GSE shipped from the CIS to the launch site.

Ground and Launch Support Facility Requirements

Facility Requirements

- o Receiving area
 - 14 feet long, 14 feet wide, 8 feet high (for uncrating are rack/console)
 - 16 feet long, 16 feet wide, and 18 feet high (for centrifuge)
- o Overhead crane (2,000 lbs. capacity)

Support Requirements

- o Fork lift truck
- o Movable dollies for racks/consolas
- o Hoisting sling for centrifuge shipping container and centrifuge
- o Centrifuge holding fixture
- o Procedures and tools for unpacking racks/consolas and centrifuge
- o Procedures and tools for hoisting and installing centrifuge in its holding fixture
- o Operators for crane and fo^lk lift trucks
- o Riggers
- o Mechanical Technicians.

ORIGINAL PAGE IS
OF POOR QUALITY

SUMMARY

I Study Objective

The objective of the Study was to evaluate the Launch Site Facility Requirements Data Sheets for selected Automated and Sortie Payloads.

The Study achieved the objective by:

- o Expanding the NASA launch site Level O functional flow activities to a depth required to identify payload launch site facility and support requirements (Volume VI contains the generic functional flow activities for Automated and Sortie payloads).
- o Conducting analyses of the payload definitions contained in the Level B Data issued by SSPD from the launch site ground processing viewpoint.
- o Processing the payloads through the expanded functional flow activities, and identifying the launch site facility and support requirements.
- o Comparing the generated requirements with those contained in the Launch Site Facility Requirements Data Sheets.

Study Recommendations

Recommendations from the Study include:

- o Expansion and revision as appropriate of the Level B Data (SSPD) to define in detail the payload ground requirements, based upon the launch site functional flow activities, as well as performing Level II (not Level III) integration at the launch site.

Specific data sheets involved are:

- On-Orbit Checkout/Monitor/Control Equipment (Data Sheet No. A-9 and A-12)
- SKETCHES (Data Sheets No. A-10, S-5, and S-6), with emphasis on the configurations at launch site arrival and installed in Orbiter cargo bay.
- Interface Diagrams (Data Sheet No. S-7) showing the interfaces for monitoring and checkout during launch site ground processing.
- Data and Communications Checkout and Deployment Support/On-orbit Operations Support (Data Sheets No. A-14, A-15, S-19, and S-20).
- Launch/Landing Support Requirements (Data Sheets No. A-18 and S-22).
- Ground Facility Requirements (Data Sheets No. A-19 and S-23).
- Ground Environmental Limits (Data Sheets No. A-20 and S-24).

SUMMARY (Continued)

II Study Recommendations (Cont'd.)

- o Definition and descriptions to Level 4 or 5 of the launch site functional flow activities.
- o Investigation of payload ground requirements at the launch site which are identified as cost drivers for ground processing in this report.

III Future Investigative Areas

Cost effective processing of payloads at the launch site requires further studies and analyses. One area which would provide fruitful results is the generation of detail scenarios of representative payloads by disciplines for Payload Working Groups approval/modification. These detail scenarios would include the ground processing for:

- o Block 1.0 Activities - Payload Pre-mission Processing
- o Block 2.0 Activities - Orbiter/Payload Integration and Checkout
- o Block 3.0 Activities - Pre-launch and Launch Operations
- o Block 4.0 Activities - Recovery Operations
- o Block 5.0 Activities - Post Mission Processing

Descriptions and required outline drawings would be provided to define in detail such ground functions and configurations as:

- o Payload and associated ground control and support equipment launch site arrival configurations, transportation and environmental modes, and arrival servicing and inspection/monitoring requirements.
- o Payload calibration
- o Monitoring
- o Checkout
- o Servicing
- o Intra-launch site transportation

The Grumman Aerospace Corporation would be pleased to assist the NASA/MSFC in performing additional studies and analyses to implement effective payload ground processing.

Block 1.4.4.1 Transport Experiment Equipment Shipping Containers to
Temporary/Long-Term Storage

This block removes the racks/consols and centrifuge shipping containers from the receiving area of the PPF, and returns them to temporary protective storage (one to two months). It is assumed that after the seven day orbit mission, the shipping containers will be reused to return the racks/consols and centrifuge to the NASA LSSL Development Center.

Ground and Launch Support Facility Requirements

Facility Requirements

- o Protective Storage area
 - Same as Block 1.4.2 above.

Support Requirements

- o Mobile crane at PPF and storage area (1,000 lbs. capacity)
- o Fork lift trucks at PPF and storage area
- o 2½ ton, closed body truck
- o Centrifuge Shipping Container Hoisting Sling
- o Operators for crane, 2½ ton truck, and fork lift truck
- o Riggers
- o Mechanical Technicians
- o Inventory Management
- o Procedures and tools for reassembly of shipping containers.

Block 1.4.5 Conduct Visual Inspection and Record Transport Sensor Reading to Verify Post-transportation Integrity of Experiment Equipment

Level B data does not specify transport sensors in the LSSL; however, it is anticipated that accelerometers and desiccants and the like will be installed to verify post-transportation integrity.

The data of these sensors are recorded and visual inspection of the racks/soles and centrifuge is performed.

Ground and Launch Support Facility Requirements

Facility Requirements

- o None

Support Requirements

- o Procedures and inspection tools (flash light, mirror, etc.) for recording sensor and performing visual inspection.
- o Mechanical Technicians.

Block 1.4.6 Move Experiment Equipment to Checkout Area in PFF

The racks/consales and centrifuge are moved from the receiving area to the checkout area in the PFF. The racks/consales are on movable dollies which may be moved by hand. The centrifuge is in its movable holding fixture which requires a tow tractor.

Ground and Launch Support Facility Requirements

Facility Requirements

- o PFF Checkout Area
 - 38 feet long, 14 feet wide, 14 feet high (for racks/consales and centrifuge verification tests accomplished in series).

Support Requirements

- o Tow tractor for Centrifuge Holding Fixture
- o Operator for tow tractor
- o Mechanical Technicians

Block 1.4.20 Experiment Equipment GSE arrives at Launch Site via _____

The LSSL GSE arrives at the launch site via commercial truck, which is selected as the transportation on the basis of economy.

Level B data does not contain definition of LSSL GSE. For Study purposes, the LSSL GSE configuration to verify racks/consoles and centrifuge interfaces is shown in Figure 1-2.

Level B data identifies various specimen preparation and receiving laboratories (Data Sheet #S-22) required for the LSSL, and indicates these items are similar to those used for Skylab and Biosatellite. Further definition is not contained in the Level B data, and therefore these GSE items are not covered in the Study.

It is recommended that a detailed functional flow diagram be prepared for ground processing of specimens at the launch site to determine appropriate facility requirements.

Ground and Launch Support Facility Requirements

The block establishes initial conditions of the LSSL GSE upon arrival at the launch site, and does not require ground and launch support facility requirements.

LSS L GSE (Typical)

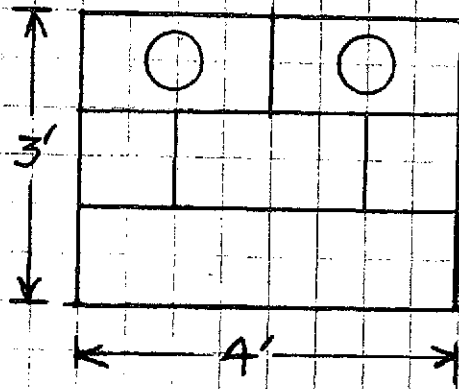

2' Deep
WT = 250 lbs
Shipping Container WT = 75 lbs

Electrical GSE
(3 racks required)

Figure 1-2

Block 1.4.21 Unload GSE from Commercial Carrier and Place in Temporary Storage

The LSSL GSE, assumed to be three racks of electrical equipment (Figure 1-2), is unloaded from commercial truck, loaded in 2½ ton closed body trucks, and moved to temporary protected storage until required for PPF processing.

Ground and Launch Support Facility Requirements

Facility Requirements

- o Protected storage area (hangar type satisfactory)
 - 36 feet long, 14 feet wide, 4 feet high

Support Requirements

- o 2½ ton, closed body, trucks
- o Fork lift trucks
- o Operators for trucks
- o Inventory Management

Block 1.4.22 Transport GSE from Temporary Storage to Receiving Area of PPF

As required for LSSL processing, the LSSL GSE is moved from temporary storage to the receiving area of the PPF.

Ground and Launch Support Facility Requirements

Facility Requirements

- o PPF receiving area (area for two electrical LSSL GSE racks)
 - 24 feet long, 14 feet wide, 4 feet high

Support Requirements

- o Fork lift trucks
- o Trucks ($2\frac{1}{2}$ ton, closed body)
- o Operators for fork lift trucks and $2\frac{1}{2}$ ton trucks
- o Inventory Management

Block 1.4.23 Unpack GSE, and Place on Movable Dolly

In the receiving area of PPF, the LSSL GSE is unpacked, and placed on movable utility dollies.

Ground and Launch Support Facility Requirements

Facility Requirements

- o None

Support Requirements

- o Fork lift trucks
- o Movable utility dollies (5 feet long, 3 feet wide)
- o Operators for fork lift trucks
- o Tools and procedures for uncrating LSSL GSE
- o Technicians for uncrating operations.

Block 1.4.23.1 Transport GSE Shipping Containers to Temporary Storage

After uncrating the LSSL GSE, the shipping containers are transported from PPF to temporary storage. It is anticipated that the LSSL GSE will re-use the shipping containers after Orbiter launch for return of LSSL GSE to the NASA LSSL Development Center.

Ground and Launch Support Facility Requirements

Facility Requirements

- o Temporary storage area
 - 36 feet long, 14 feet wide, 4 feet high

Support Requirements

- o Fork lift trucks
- o Trucks (2½ ton)
- o Operators for fork lift trucks and 2½ ton trucks
- o Inventory Management
- o Tools and procedures for reassembly of shipping containers.

Block 1.4.24 Conduct Visual Inspection and Record Sensor Readings to
Verify Post-transportation Integrity

The assumption is made that the LSSL GSE has no installed transport sensors, so sensor recordings are not applicable.

A visual inspection of the LSSL GSE is made to verify post-transportation integrity.

Ground and Launch Support Facility Requirements

Facility Requirements

- o None

Support Requirements

- o Procedures and inspection tools (flash light, mirrors, etc.) for performing visual inspection.
- o Technicians for conducting inspection.

Block 1.4.25 Move GSE to Checkout Area of PPF

The LSSL GSE, mounted on movable utility dollies, is moved from the receiving area to the checkout area in the PPF.

Ground and Launch Support Facility Requirements

Facility Requirements

- o PPF Checkout Area
 - 20 feet long, 12 feet wide, 5 feet high for utility dollies

Support Requirements

- o Mechanical Technicians

ORIGINAL PAGE IS
OF POOR QUALITY

Block 1.5 Load and Verify Flight Software

It is felt that this block includes some interface with Experiment Equipment, and as the Experiment Equipment has not yet been installed in the Spacelab, this block will be inserted later in the flow (See Block 1.5 insert between Blocks 1.12 and 1.13).

Block 1.6 Racks/Rack Sets/Floor Assembly Installation

Note: This block has been changed to include a verification test of Racks/Rack Sets/Floor Assemblies interfaces prior to installation into the Spacelab. The justification of this change is that malfunction detection is more economical and has less probability of impacting the Shuttle launch schedule when performed on a "build-up" basis instead of on a "system" basis. In addition, the equipments ^{7 has} ~~have~~ not been functionally checked since launch site arrival, and to delay the check until after installation into the Spacelab appears to invite duplication of installation/removal activities and resulting increases in time requirements and costs for ground operations.

The concept is to functionally verify the interfaces of the individual Racks/Rack Sets/Floor Assemblies prior to installation into the core and experiment segments of the Spacelab, and after installation, to perform a functional end-to-end verification of the interfaces between the installed equipment and Spacelab and Orbiter.

Block 1.6.1 through Block 1.6.5 cover the before installation verification, and Block 1.6.9 through Block 1.6.12 cover the after installation verification.

ORIGINAL PAGE IS
OF POOR QUALITY

Block 1.6.1 Perform Functional Check and Calibration of GSE

It is assumed that the LSSL GSE requires no calibration, and that the functional check of the LSSL GSE is conducted using standard test equipment. Since the definition of LSSL GSE is TBD, the requirements for standard test equipment is TBD at this time.

Ground and Launch Support Facility Requirements

Facility Requirements

- o Electrical Power - TBD
- o Calibration Lab - TBD

Support Requirements

- o Standard test equipment - TBD
- o Checkout/Calibration Procedures - TBD
- o Technicians to perform checkout/calibration.

Block 1.6.2 Connect GSE to Pallet Sections Requiring Calibration, and Calibrate Pallet Sections

Level B data of LSSL does not identify calibration requirements for the racks/panels and centrifuge, therefore, these requirements are TBD.

Ground and Launch Support Facility Requirements

- o TBD.

Block 1.6.3 Connect GSE to Experiment Equipment Interfaces

Block 1.6.4 Perform Verification Tests of Experiment Equipment Interfaces

Block 1.6.5 Remove Experiment Equipment Verification GSE

These three blocks conduct the interface verification tests on the racks/ consoles and centrifuge. Level B data defines interfaces in broad terms, and two concepts are described below. The first concept applies to either a rack or a console whose only interface involves the Spacelab and contains no interfaces with other racks or consoles. The second concept applies to racks and consoles which contain both type interfaces, that is, contain interfaces with other racks or consoles and also with the Spacelab.

First Concept (Racks/consoles interfaces with only Spacelab)

- o Connect GSE to racks/consoles interface.
- o GSE furnishes power and signal input stimuli to racks/consoles, and receives power from facility.
- o GSE receives output response from racks/consoles and evaluates racks/consoles performance.
- o Disconnect GSE.

Second Concept (Racks/consoles interfaces with other racks/consoles

- o and with Spacelab)
- o Connect GSE to racks/consoles interfaces to other racks/consoles.
- o GSE furnishes power and signal input stimuli to racks/consoles, and receives power from facility.
- o GSE receives output response from racks/consoles and evaluates racks/consoles performance.
- o Disconnect GSE.
- o Mate interfaces between racks/consoles.
- o Connect GSE to racks/consoles interfaces to Spacelab.
- o GSE furnishes power and signal input stimuli to racks/consoles, and receives power from facility.

Second Concept (continued)

- o GSE receives output response from racks/conssoles and evaluates racks/conssoles performance.
- o Disconnect GSE.

Ground and Launch Support Facility Requirements

(Omitted are the requirements to support the Life Sciences Preparation and Post-flight Receiving Laboratories. Typical requirements listed on Data Sheet #S-23 include water, LN₂, H₂, O₂, high pressure air, natural gas, CO₂, controlled lighting, Vacuum, chilled water supply, and cold storage. See recommendation contained in Block 1.4.20.)

Facility Requirements

- o PPF checkout area
 - 48 feet long, 24 feet wide, 7 feet high to support checkout of three racks/conssoles.
 - Contingency for centrifuge checkout; 15 feet long, 8 feet wide, 15 feet high.
- o Electrical power - TBD.

Support Requirements

- o Procedures and tools for mating/unmating GSE
- o Procedures for conducting interface verification tests
- o Data/computer processing (parameters - TBD)
- o Film storage
- o Electrical/Mechanical Technicians.

Block 1.6.6 Inspect Experiment Equipment to Verify Configuration is Correct for Installation into Spacelab

Note: This block has been expanded for the LSSL to include the installation of the racks/conssoles to the core and experiment segments floor assemblies.

The racks/conssoles and experiment segments floor assemblies are verified as to proper configuration, and positioned for installation of the racks/conssoles.

The racks/conssoles are hoisted from their movable dollies, lowered onto the floor assemblies and secured. If interfaces between racks/conssoles require unmating for securing the racks/conssoles to the floor assemblies, the interfaces are re-united at the completion of mating racks/conssoles and floor assemblies.

The mounting of the centrifuge on a floor assembly is considered a special case in that its support and floor mounting would be a dedicated design.

Ground and Launch Support Facility Requirements

Facility Requirements

- o Overhead crane (5,000 lbs. capacity)
- o PPF checkout area
 - 28 feet long, 20 feet wide, 8 feet high for racks/conssoles
 - 15 feet long, 8 feet wide, 15 feet high for centrifuge.

Support Requirements

- o Inspection procedures, tools and configuration descriptions/drawings of racks/conssoles and centrifuge.
- o Core and experiment segments floor assemblies.
- o Procedures and tools for installing racks/conssoles and centrifuge to floor assemblies.
- o Fork lift trucks.
- o Hoisting slings for racks/conssoles and centrifuge.
- o Movable floor assembly handling dollies.

Block 1.6.7 Attach GSE Handling Slings and Obtain and Position
Materials Handling Equipment

This block prepares the floor assemblies now containing the racks/consols and centrifuge for loading into the Spacelab.

The materials handling equipment for the loading operation is that described in the "Spacelab, Preliminary Technical Description" document. (Page 46 - Loading/Unloading Concept of Rack Assembly).

The hoisting slings are attached to the floor assemblies.

The "Loading/Unloading Concept of Rack Assembly" is placed in position to load the core and experiment segments.

Ground and Launch Support Facility Requirements

Facility Requirements

- o PFF checkout area
 - 60 feet long (Spacelab - 37 feet, loading/unloading assembly - 20 feet, clearance - 3 feet), 21 feet wide (Spacelab - 15 feet, clearance 3 feet each side), and 20 feet high (Spacelab and stand - 18 feet, clearance - 2 feet).

Support Requirements

- o "Loading/Unloading Concept of Rack Assembly" - fixture shown on page 46 - Spacelab, Preliminary Technical Description
- o Hoisting sling for floor assemblies
- o Procedures and tools for positioning "Loading/unloading Concept of Rack Assembly"
- o Procedures and tools for attaching floor assembly hoisting slings
- o Riggers
- o Mechanical Technicians.

Block 1.6.8 Move Experiment Equipment into Spacelab and Secure all Interfaces; Remove GSE Handling Slings and Materials Handling Equipment

This block moves the racks consoles and centrifuge into the core and experiment segments, and mates the floor assemblies to the support structure of the core and experiment segments.

Although the operational details of the "Loading/Unloading Concept Rack Assembly" fixture are not defined, it is assumed that the racks/consoles are manually handled on the fixture. For installation of the centrifuge, the fixture appears not applicable, and an overhead crane positions the centrifuge and its support structure.

Ground and Launch Support Facility Requirements

Facility Requirements

- o Overhead crane (capacity 2,000 lbs.)

Support Requirements

- o Procedures and tools for operating "Rack Assembly" fixture
- o Procedures and tools for mating floor assemblies
- o Procedures and tools for installation of centrifuge
- o Riggers
- o Operator for crane
- o Mechanical Technicians.

Block 1.6.9 Perform Functional Check and Calibration of GSE as Required

Block 1.6.10 Connect GSE to Experiment Equipment

Block 1.6.11 Perform Verification Tests of Experiment Equipment Interfaces

Block 1.6.12 Remove Experiment Equipment Verification GSE

The blocks are not applicable to the LSSL, since the LSSL interfaces have been verified prior to loading into the core and experiment segments.

Block 1.7 Mate Special Experiment Sections

This block is not applicable to LSSL.

Block 1.8 Receive and Inspect Pallet Sections

This block is not applicable to LSSL.

Block 1.9 Install Crew Transfer Access Tunnel and Aft Bulkhead

This block is not applicable to the Study. However, the following comments are offered.

The installation of the Access Tunnel requires forward and aft interface connections, as well as a supporting structure between the interfaces. There seems to be no provisions for these requirements in the functional flow descriptions. It is recommended that the Cargo Bay Simulator (CBS) be used to support the installation of the Access Tunnel. Its use would modify the top level functional flow descriptions to include first use of the core and experiment segments installed in the CBS, and would eliminate the need for the "Rack Assembly" fixture previously mentioned, since the loading of core and experiment segments could be accomplished using the CBS.

With regard to installing the Aft Bulkhead at this time in the functional flow, it is noted that if any equipment change-out is required, either in the Spacelab subsystems or the LSSL, after this block (Block 1.9), such changed equipment must ^{center} access the core/experiment segments either via the Access Tunnel or the Access Hatch in the Aft Bulkhead. It should also be noted that verification tests using the Orbiter Simulator have not been conducted up to this point in the functional flow.

It is recommended that installation of the Aft Bulkhead be delayed until after completion of Block 1.14 (Service Non-time Critical Items) and prior to Block 1.15 (Perform Pressure Integrity Tests).

LSSL Level B data does not define in detail whether or not the installed centrifuge at the Aft end of the experiment segment prevents access. If access is closed, consideration should be given to installing the centrifuge just prior to Aft Bulkhead installation to permit maximum equipment change-out prior to conducting the operations of Block 1.15 (Perform Pressure Integrity Tests).

Block 1.10 Mate Pallet with Pressurized Sections

Note: For the LSSL, this block is interpreted to mate the racks/consoles and centrifuge with the Spacelab interfaces in the core and experiment segments.

It is observed that the racks/consoles and centrifuge, on their floor assemblies, were installed, and the interfaces between groups of racks/consoles were mated in Block 1.6.8 above. The interfaces between the core/experiment segments and LSSL were not mated which are accomplished in this block.

It is assumed that the core/experiment segments side of these interfaces have been verified. The racks/consoles and centrifuge interface sides were verified prior to installing into the core/experiment segments.

Therefore, and based upon the above assumptions, the interfaces between core/experiment segments and the racks/consoles and centrifuge are mated.

Ground and Launch Support Facility Requirements

Facility Requirements

- o None

Support Requirements

- o Procedures and tools for mating interfaces
- o Electrical Technicians

Block 1.11 Mate Pallet Sections with Liaison Pallet

This block is not applicable to LSSL.

Block 1.12 Connect Orbiter Simulator

This block is not applicable to the study.

However, the following comments are offered: For the LSSL, some type of "Holding Fixture" for the Spacelab is required during PFF processing. It is recommended that this "Holding Fixture" be an Orbiter Cargo Bay Simulator (CBS) whose forward bulkhead duplicates the forward end of the Orbiter Cargo Bay. This CBS forward bulkhead then serves as the interface between the Orbiter Simulator and the Spacelab.

The Orbiter Simulator consists of various rack-mounted equipments ^{ON} or movable dollies which simulate the Orbiter PSS/MSS equipment and payload equipment located in the Orbiter cabin.

This block mates the Orbiter Simulator to the forward bulkhead of the Cargo Bay Simulator (CBS).

Block 1.5 Load and Verify Flight Software

All equipment is now assembled for flight software verification; that is, the Orbiter Simulator duplicates the PSS/MSS stations and the LSSL equipment located in the Orbiter cabin, and the core/experiments segments are complete. All interfaces have been mated and verified.

LSSL Level B data (Data Sheet #5-7) indicates interface functions with the Spacelab Data Management & Communication System for data storage and ground communications. As related to these functions, the flight software is verified in this block.

It is anticipated that software verification will be conducted by launch site personnel, and is, therefore, not detailed here.

Block 1.13 Final Integrated Systems Tests

This block verifies the interface between the Orbiter Simulator and those Spacelab elements which mate with the Orbiter Simulator. This definition is in keeping with the ground rule of verifying interfaces at the launch site, and since all interface between the Spacelab and LSSL have been verified previously in the functional flow activities, the Final Integrated Systems Tests involve only the interface at the Cargo Bay Simulator (CBS) forward bulkhead between the Spacelab and the Orbiter Simulator. Those interfaces are based upon JSC07700, Volume XIV, "Payload Accommodations".

The LSSL involvement in these tests is limited to electrical power (LS003) and data management (LS002). In case it is not feasible to operate LS003 and LS002 for these tests, their operation would be simulated by appropriate LSSL GSE.

Ground and Launch Support Facility Requirements

Facility Requirements:

- o None (from LSSL viewpoint)

Support Requirements:

- o GSE simulated electrical power load (contingency)
- o GSE simulated data management rig (contingency)

Block 1.14 Service Non-Time Critical Items

The LSSL Level B data does not include non-time critical service items. Candidates include various compressed gas cylinders, film, chemicals, and specimens (non-time critical) which do not require monitoring.

It is noted also that unless the functional flow activities are modified as recommended in Block 1.9, the aft bulkhead has been installed thereby limiting access to the Spacelab via the Access Tunnel (assuming the centrifuge prevents entry into the Spacelab via the aft bulkhead hatch).

Ground and Launch Support Facility Requirements

Facility Requirements

- o None

Support Requirements

- o Procedures for storage/servicing LSSL non-time critical items
- o Technicians

Block 1.15 Perform Pressure Integrity Tests

(As written, this block appears to duplicate interface verification tests which have been completed in Block 1.13 - Final Integrated Systems Tests. For instance, Block 1.13 has verified all element interfaces and subsystems performance, and it is assumed that these tests would have located and corrected any pressure leaks in all system/subsystem plumbing which is defined as a portion of Block 1.15 Pressure Integrity Tests. In keeping with the ground rule of eliminating duplicate tests, it is suggested that the activities in this block be limited to pressure integrity tests of the access tunnel, the core and experiment segments. Such a pressure integrity test would not involve the LSSL, and, therefore, is not detailed here.)

Block 1.16 Disconnect Orbiter Simulator

(This activity disconnects the interfaces between Orbiter Simulator and Spacelab, and secures the interfaces on the Spacelab. This activity does not involve the LSSL, and, therefore, is not detailed here.

However, although not defined in the LSSL Level B data, the Orbiter Simulator may contain rack-mounted LSSL equipment which is located in the Orbiter cabin during the flight mission. The processing of this equipment follows below, and is defined as "LSSL Cabin Equipment".)

Block 1.16.1 Disconnect interface between Orbiter Simulator and LSSL Cabin Equipment.

Block 1.16.2 Install protective devices on LSSL Cabin Equipment interfaces, and secure interfaces for transport.

Block 1.16.3 Install protective covers on LSSL Cabin Equipment, and move equipment clear of Orbiter Simulator.

Ground and Launch Support Facility Requirements

Facility Requirements:

- o None

Support Requirements:

- o Procedures and tools for unmating LSSL Cabin Equipment
- o Procedures and tools for installation of protective devices/covers
- o Protective devices/covers for LSSL Cabin Equipment
- o Electrical/Mechanical Technicians

Block 1.17 Move to OFF

(This activity moves the payload from the Payload Processing Facility (PPF) to the Orbiter Processing Facility (OPF). It involves a transporter, protective covers, and GSE required during towing operations from PPF to OPF. (Three (3) hours tow time allocated.) The transporter is assumed to be the Cargo Bay Simulator previously described. Support for experiments during the towing operation can be divided into two classes, namely support of experiments located in the Experiment Module which is normally furnished by an active Support Module which, in turn, is supported by an active Orbiter, and support of experiments pallet-mounted which, except for cleanliness support, receives support in a similar manner. Supplemental support available to the payload in the form of igloos and the like is not considered at this time.

The experiment support required during towing then may be classified as:

- o Orbiter derived
- o Cleanliness requirements

It is assumed that GSE which duplicates the Orbiter support is available, and can be located to interface with the forward bulkhead of the Cargo Bay Simulator during tow operations.

The experiment cleanliness requirements within the Experiment Module will be satisfied by the closed system (Access tunnel hatches closed). The Cabin Experiment Equipment is transported separately, and not with the Spacelab.

The preparation of the Spacelab within the Cargo Bay Simulator and the towing operation from the PPF to the OPF is not considered an experiment-related function, and therefore is not detailed here. There remains the cleanliness requirements for the pallet-mounted experiments which are detailed below.

- Block 1.17.1 Contingency mode for malfunction correction.
- Block 1.17.2 Position GSE on trailer which accompanies Cargo Bay Simulator during tow from PPF to OFF.
- Block 1.17.3 Install protective covers on pallet-mounted experiments.
- Block 1.17.4 Connect GSE to protective covers.
- Block 1.17.5 Power up GSE and supply cleanliness requirements, and monitor GSE output.

For the LSSL, the Level B data indicates ground environmental limits are TBD (Data Sheet #S-24). Considering that the LSSL during the move from PPF to OFF consists of racks/conssoles, the centrifuge and non-time critical items stowed, and all of this equipment in place in the core and experiment segments with all hatches closed, - it is anticipated that the LSSL has no requirements during the transfer operation.

Ground and Launch Support Facility Requirements

- o None.

1.0 Premission Processing

A. Storage Area

AREA (Ft²)

(400)

- o 54 ft. long, 14 ft. wide, 8 ft. high for racks/conssoles. 16 ft. long, 6 ft. wide, 16 ft. high for centrifuge. 36 ft. long, 14 ft. wide, 4 ft. high for LSSL GSE.

TEMP(°K)

(297±3 = 74°F±6)

RELATIVE HUMIDITY(%)

(< 60)

CLEANLINESS CLASS

(100K)

- o Study lists no requirements for these parameters. It is assumed that storage will be in hangar-type protected areas, and with the LSSL in its shipping containers, the Study concluded no environmental requirements are needed.

B. Special Area Requirements

(Notes 2 and 5 describe in-place Zoolog Lab used for Skylab/Biosatellite Prep and Receiving Laboratories in O&C Building. Study confirms available facilities.)

Other

(Vacuum Chamber - TBD)

- o Study does not list vacuum chamber as a requirement. Level B data contains no requirement for a vacuum chamber.

LAUNCH SITE FACILITY REQUIREMENTS (PHYSICAL)

2.0 Orbiter/Payload Mate and Integrate (Life Sciences Shuttle Lab)
(Storage Area 400 ft², Temp 297 ± 3°K, Humid 60, Cleanliness Class
100,000)

o In functional block 2.0 no function for storage is defined; therefore
the requirement does not exist (at this functional time).

o Office

(6 Engr./Scientists, 9 Technicians)

Insufficient information in Level B data to recommend a change.

Block 2.0 Orbiter/Payload Integration and Checkout - Mission No. 14

The activities in this functional block begin with the arrival of the integrated payload elements of the Spacelab, at the mating area of the Orbiter Processing Facility and include all those efforts required to physically and functionally mate the payload to the Orbiter Payload Bay, and install any equipment required for the mission in the Payload Specialist Station.

Figure 2.2-1 graphically depicts this flow.

The prerequisites for entering this block are as follows:

- o All elements requiring integration have been integrated.
- o Required GSE, STE, facility services, and personnel are available.
- o Orbiter processing has progressed to the required point in its turnaround flow and is ready to accept the Payload.

Block 2.1 Install Payload in Orbiter Payload Bay

Conditions: Spacelab is in position and access stands are in place.

Block 2.1.1 Lock transporter in position and remove all transport covers.

Block 2.1.2 Verify no transport damage has been incurred and payload and associated hardware is in a mate condition (visual inspection).

Block 2.1.3 With the overhead crane in position, attach the auxiliary crane control to the hook and the hoisting GSE to the crane control. Raise the assembled functional set and attach to payload hoist points.

NOTE: Exercise caution to avoid damage to the access tunnel seal.

Block 2.1.4 Using the auxiliary control, apply a load of TBD pounds as indicated on the dial face. Unlatch all transporter hold down points and raise payload clear of the transport unit.

Block 2.1.5 Hoist and position in payload bay. Using the auxiliary control lower onto the orbiter support points.

Block 2.1.6 Install all related mission equipment in the Payload Specialist Station.

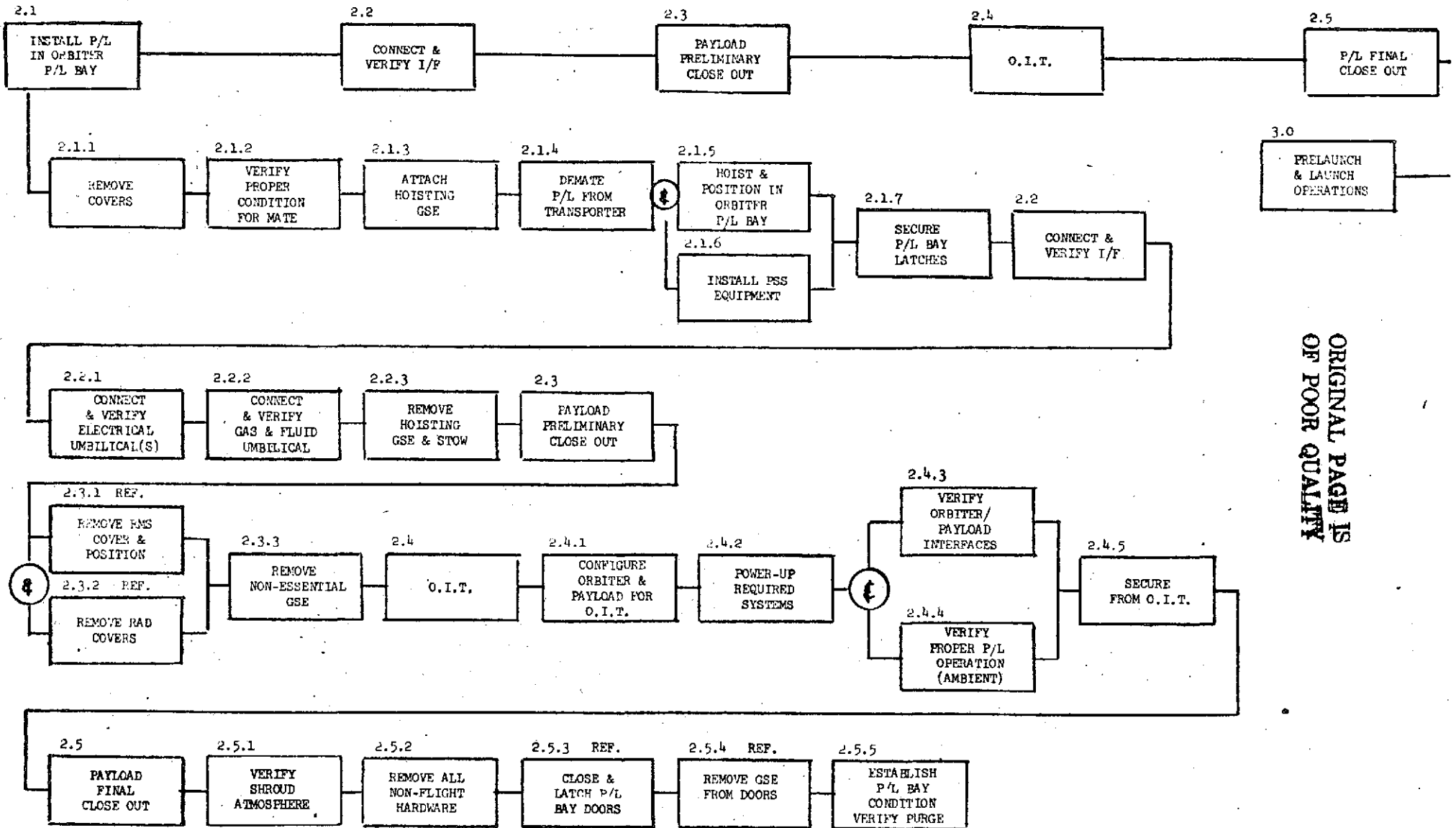

ORIGINAL PAGE IS
OF POOR QUALITY

FIGURE 2.2-1 ORBITER/PAYLOAD INTEGRATION

Block 2.1.7 Secure all payload bay latches and verify.

Support Requirements Functional Block 2.1

Facilities

Floor space 840 sq. ft. (30 x 28)

Overhead crane 10 ton capacity

Ground Support Equipment

Hoist Equipment, Functional Set

Stands, Access

Auxiliary Crane Control

Support

Crane Operator

Logistics

Procedures

Block 2.2 Connect and Verify Orbiter/Payload Interfaces

Conditions: Spacelab is mechanically mated to the Orbiter and latch down has been verified.

Block 2.2.1 Verify power off on both sides of the electrical interface. When verified, mate the Orbiter to Spacelab umbilical(s).

Block 2.2.2 Verify no pressure or fluid present at either side to the fluid/gas interface, remove caps and mate fluid/gas umbilical.

NOTE: Present ERNO Spacelab description indicates a single utility bridge combining fluid and electrical interfaces in one unit.

Block 2.2.2.1 Verify tunnel seal surfaces clean and intact, mate tunnel to orbiter interface.

Block 2.2.3 Disconnect hoisting GSE and hoist clear of payload bay, retain in the area.

Support Requirements for Functional Block 2.2

Support requirements remain the same for this function, all GSE remains until completion of OIT.

Block 2.3 Payload Preliminary Closeout

Conditions: Payload has been physically and functionally mated to the Orbiter.

Block 2.3.1 Remove protective covers from the Remote Manipulator System (RMS) arms. (Reference only, not a payload function).

Block 2.3.2 Remove protective covers from the payload bay door mounted radiators. (Reference only, not a payload function).

Block 2.3.3 Remove all non-essential GSE and stow. Retain in area.

Support Requirements for Functional Block 2.3

Same as 2.2

Block 2.4 Perform Orbiter Integrate Test (OIT)

Conditions: Preliminary payload close out has been completed. Orbiter support available and verified.

Block 2.4.1 Configure orbiter, payload, and associated GSE to support OIT position switches and circuit breakers per test procedures and verify.

Block 2.4.2 Apply ground power to the required systems and verify proper level and distribution.

Block 2.4.3 Verify functional path through Orbiter/Payload interface paths.

Block 2.4.4 Verify proper signal format and level for all operating payload elements.

Block 2.4.4.1 Figure 2.2-2 is a graphic representation of a typical anomaly loop and indicates various options in effecting corrective action. Once the anomaly has been isolated, the decision on which path to follow will be a "real time" decision based on repair requirements and/or mission criticality. It is assumed that any anomaly associated with the Orbiter or the Institutional Ground Support Equipment will be the responsibility of KSC operational personnel, while anomalies within the payload elements or Peculiar Ground Support Equipment will be corrected by the payload operations personnel.

ORIGINAL PAGE IS
OF POOR QUALITY

ORIGINAL PAGE IS
OF POOR QUALITY

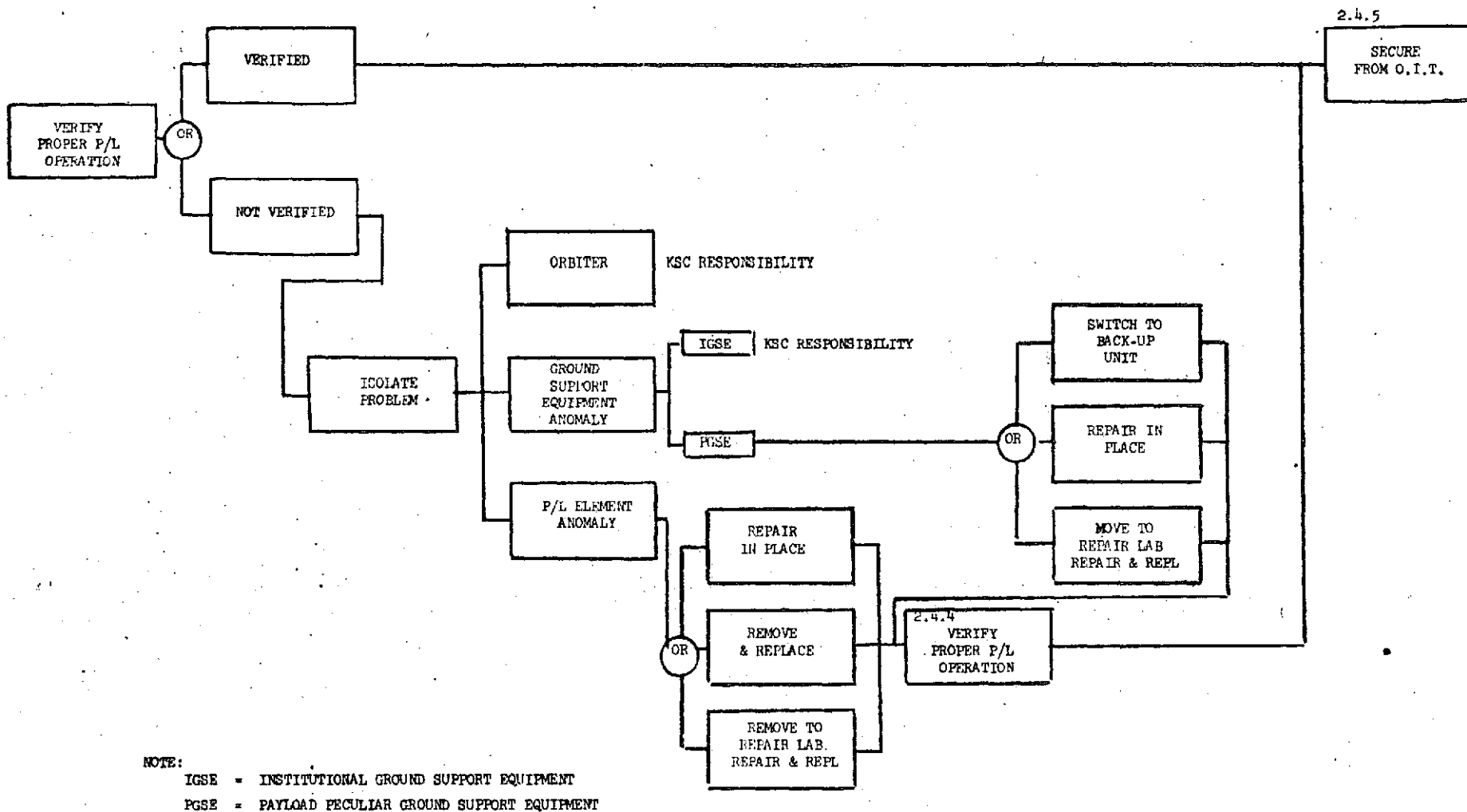

FIGURE 2.2-2 TYPICAL ANOMALY FUNCTIONAL LOOP

Block 2.4.5 Upon final verifications of the correct readouts and functional interfaces, secure from O.I.T. power down active systems and position all switches and circuit breakers as called for in the O.I.T. procedures.

Support Requirements for Functional Block 2.4

Facilities

Same as 2.1 plus 115VAC, 1Ø, 60Hz, 28VDC (power level) TBD.

Ground Support Equipment

Cable sets, checkout

Hose sets, checkout and service

HIM's, LPS interface TBD

Support

Logistics

Procedures

Block 2.5 Payload Final Close-out

Conditions: Orbiter Integrated Test has been completed. Orbiter and Payload have been secured.

Block 2.5.1 Service flight systems as required.

Block 2.5.1.1 Fill compressed gas cylinders as follows:

N₂, O₂, CO₂ and natural gas to TBD PSI.

Service H₂O container to TBD pounds.

Service LN₂ dewar.

NOTE: This servicing may be done as part of OIT.

Block 2.5.2 Remove all non-flight hardware from the payload bay and any non-flight equipment from the payload specialist station.

Block 2.5.2.1 Return all payload handling/checkout GSE to its proper position.

NOTE: This PGSE may be stored at the launch site or returned to the

PI or CIS facility.

Block 2.5.3 Close and latch payload bay doors, (Reference only, not a payload function).

Block 2.5.4 Remove payload bay doors GSE and return to storage (Reference only, not a payload function).

Block 2.5.5 Establish payload bay conditioning purge, verify payload bay conditioning within specification (Joint responsibility, Orbiter and Payload).

Support Requirements for Functional Block 2.5

Facilities

Same as 2.1

Ground Support Equipment

Service sets, N₂, O₂, CO₂, natural gas.

Service set, H₂O portable.

Service set with dewar, LN₂.

Support

As required to provide listed gas/fluid media.

This function ends with the Orbiter/Payload ready to prepare for transfer to the VAB.

Scenario: Activity 3.0 Prelaunch and Launch Operations

All payload operations are covered in this activity from tow of orbiter VAB, mating orbiter in VAB, and preparations at PAD until liftoff. During these periods this activity is concerned with payload monitoring, launch readiness verification interface checks and final servicing prior to launch.

Block 3.1 Monitor Payload

After completion of payload final closeout in OPF this activity begins and ends with MLP hard mounted at PAD. During this period the payload status, the environmental control system, data system, and power systems are continuously monitored. The monitoring requirement exists through all activities up to shuttle liftoff, so that the payload integrity is not affected in anyway in which it would affect its performance during orbit.

Block 3.1.3 Monitor Payload Status

While in tow until MLP on hardmounts at PAD, the payload power system, environmental requirements and LN₂ loaded on board the payload experiments are monitored.

Facility Requirements

- o Data Processing - via^{1a} Orbiter Ground Link
- o Power 110VAC, 400Hz, 1.5KW, 3Ø
28VDC, 1.5KW

Support Requirements

- o Environmental Control - Aux Equip - TBD

Block 3.1.1.2 Payload Status Anomaly

During this activity an anomaly could be loss of power, which would result in payload/spacelab monitoring capabilities, or the failure of the environmental control system or data systems.

Facility Requirements

- o Data Processing - via Orbiter Ground Link
- o Power - 110VAC, 400Hz, 1.5KW, 3Ø
28VDC, 1.5KW

Support Requirements

- o Environmental Control - Aux Equip - TBD

Block 3.1.1.3 Isolate Anomaly

The technician monitoring payload would have to observe conditions, and try to isolate problems to a particular system.

Facility Requirements

- o Data Processing - via Orbiter Ground Link
- o Power - 110VAC, 400Hz, 1.5KW, 3 ϕ
28VDC, 1.5KW

Support Requirements

- o Environmental Control - Aux Equip - TBD

Block 3.1.1.4 Troubleshoot and Repair

When in tow, the technician/engineer will determine course of action to troubleshoot after the MLP is hardmounted at PAD. At that time the technician/engineer will proceed to troubleshoot and repair anomaly.

Facility Requirements

- o Data Processing - via Orbiter Ground Link
- o Power - 110VAC, 400Hz, 1.5KW, 3 ϕ
28VDC, 1.5KW

Support Requirements

- o Environmental Control - Aux Equip - TBD

Block 3.1.1.5 Verify System

Upon completion of repair of system, a verification test would be performed to verify system functions as required to maintain integrity of payload.

Facility Requirements

- o Power - 110VAC, 400Hz, 1.5KW, 3 ϕ
28VDC, 1.5KW

Support Requirements

- o Environmental Control - Aux Equip - TBD

Block 3.1.2 Payload Status Monitoring

A continuous effort until liftoff to observe payload monitoring requirements function as required to maintain integrity of payload.

Facility Requirements

- o Data Processing - via Orbiter Ground Link
- o Power - 110VAC, 400Hz, 1.5KW, 3Ø
28VDC, 1.5KW

Support Requirements

- o Environmental Control - Aux Equip - TBD

Block 3.2 Launch Readiness Verification

Begins with arrival at MLP at launch pad and MLP hard down on PAD mounts, and ends with cabin hatch in closed position. During this period the payload will be monitored, as in Activity 3.1, the launch readiness payload verification checks will be performed, live specimens loaded on payload/Spacelab for mission.

Block 3.2.1 Payload Status Verification

After arrival at PAD, access to the Orbiter payload Specialist Station to perform an orbiter to payload interface verification. The verification would check the operational capabilities of the controls and switches required to operate the payloads on orbit, and verify interfaces for command, and data acquisition and processing.

Facility Requirements

- o Data Processing - via Orbiter Ground Link
- o Power - 110VAC, 400Hz, 1.5KW, 3Ø
28VDC, 1.5KW
- o Monitoring - LPS

Support Requirements

- o Environmental Control - Aux Equip - TBD
- o Biolog - LAB - Portable at Launch Site
- o Handling Equipment - Experiments

Block 3.2.1.1 (continued)

Whatever the anomaly, we would proceed to resolve anomaly prior to liftoff.

Facility Requirements

- o Data Processing - via Orbiter Ground Link
- o Power - 110VAC, 400Hz, 1.5KW, 3 ϕ
- 28VDC, 1.5KW
- o Monitoring LPS

Support Requirements

- o None

Block 3.2.1.2 Isolate Anomaly

The technicians/engineers performing the verification checks would isolate the anomaly to either Ground Support Equipment, Payload/Experiment or Orbiter Systems. After the anomaly has been isolated a typical approach to resolution of problem is shown on Figure 3.1. The GSE/Payload/Experiment - Off-line maintenance would be performed by experimenter. Orbiter Systems maintenance resolution would be KSC responsibility.

Facility Requirements

- o Data Processing - via Orbiter Ground Link
- o Power - 110VAC, 400Hz, 1.5 KW, 3 ϕ
28VDC, 1.5KW
- o Monitoring LPS

Support Requirements

- o None

Block 3.2.1.3 Troubleshoot and Repair

A typical approach is shown on Figure 3.1.

Facility Requirements

- o Materials Analysis Lab
- o Clean Lab
- o Data Processing
- o Calibration
- o Battery Lab and Storage

ORIGINAL PAGE IS
OF POOR QUALITY

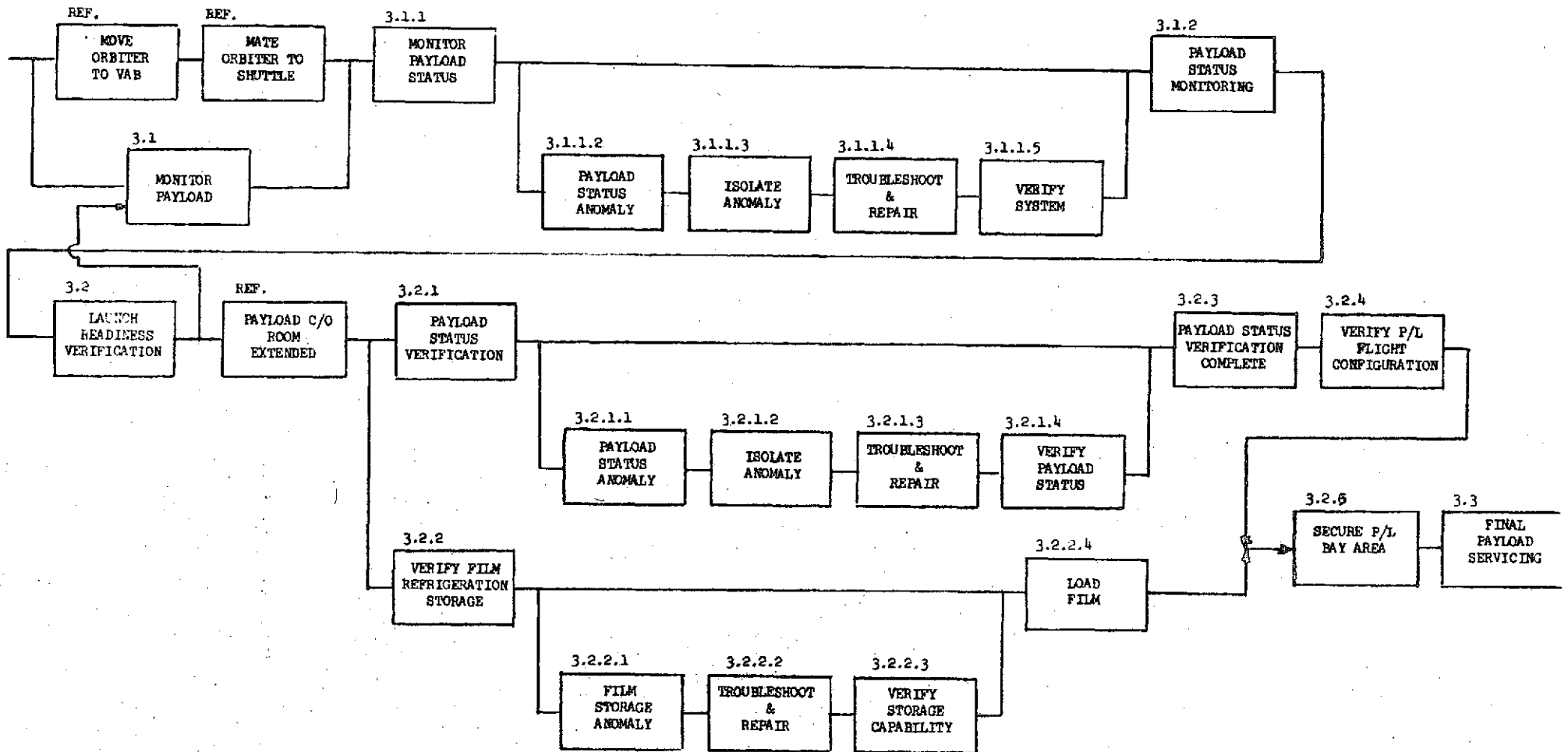

ACTIVITIES 3.1 MONITOR PAYLOAD AND 3.2 LAUNCH READINESS VERIFICATION

Figure 3.1

Facility Requirements (continued)

- o , Radiological Lab
- o Film Lab
- o Machine Lab
- o Zoology Lab
- o Elect Lab
- o Vacuum Chamber

Support Requirements

- o Transportation
- o Biology Lab - Portable Type
- o X-Ray
- o Slings
- o Forklifts
- o Cranes

Block 3.2.1.4 Verify Payload Status - Off-Line

After the resolution of the Spacelab/Payload/Experiment/GSE anomaly, a verification check would be made prior to installation in payload bay to show that it can now support the defined performance requirements of the mission.

Facility Requirements

- o Materials Analysis Lab
- o Clean Lab
- o Data Processing
- o Calibration Lab
- o Battery Lab and Storage
- o Radiological Lab
- o Film Lab
- o Machine Lab
- o Zoology Lab
- o Meth Lab

Facility Requirements (continued)

- o Biology Lab
- o Elect Lab
- o Vacuum Chamber

Support Requirements

- o GSE - TBD
- o Special Test Equipment - TBD
- o Transportation
- o Biology Lab - Portable Type
- o Slings
- o Forklifts
- o Cranes

Block 3.2.2 Verify Film Refrigeration Storage

A verification check is performed to check Spacelab storage environment prior to loading film on experiments in payload bay.

Facility Requirements

- o Power - Orbiter power for Spacelab environmental system

Support Requirements

- o None

Block 3.2.2.1 Film Storage Anomaly

Return film to storage area until environmental anomaly is resolved.

Facility Requirements

- o Power - Orbiter power for Spacelab environmental system

Support Requirements

- o Transportation

Block 3.2.2.2 Troubleshoot and Repair

A typical approach is shown in Figure 3.1.

Facility Requirements

- o Mech Lab - if off-line

Block 3.2.2.2

Facility Requirements (continued)

- o Elect Lab - if off-line
- o Power - Orbiter power for Spacelab environmental system

Support Requirements

- o Transportation

Block 3.2.2.3 Verify Storage Capability

After resolution of environmental anomaly verify the storage unit is ready for film storage.

Facility Requirements

- o Power - Orbiter Power for Spacelab environmental unit

Support Requirements

- o None

Block 3.2.2.4 Load Film

The verification check of the storage unit was performed with no problem, and if an anomaly did occur it has since been resolved and the film can now be placed on-board the orbiter.

Facility Requirements

- o Power - Orbiter power for Spacelab environmental system

Support Requirements

- o None

Block 3.2.3 Payload Status Verification Complete

The verification check was performed with no problems, and if an anomaly did occur it has since been resolved and the payload is ready for flight.

Facility Requirements

- o Data Processing - via Orbiter Ground Link
- o Power - LLOVAC, 60Hz, TBD(KW)
- 28VDC, TBD(KW)

- o Monitoring LPS

Block 3.2.4 Verify Payload Flight Configuration

Prior to securing OBSS, Spacelab and payload bay a check is made to verify that all experiments, controls, switches, etc. are in flight readiness configuration.

Facility Requirements

- o Data Processing - via Orbiter Ground Link
- o Power - 110VAC, 60Hz, TBD(KW)
- 28VDC, TED(KW)
- o Monitoring LPS

Support Requirements

- o None

Block 3.2.5 Secure Payload Bay Area

Secure all PPE used in verification checks between OPSS, Spacelab and Payload.

Facility Requirements

- o None

Support Requirements

- o TBD

Block 3.3 Payload Final Servicing

During this period the payload will be monitored, as in Activity 3-1 through liftoff. The payload final servicing will consist of hydrazine loading, LN₂ top-off and ^{oa}loading the live specimens on board prior to launch. Access is required through Orbiter cabin to Spacelab, and to Payload Bay Area through Payload changeout room. In parallel off-line support the LN₂ dewars will be prepared for servicing, so as to be ready when LN₂ top-off is required. After final servicing, the Payload/Spacelab/Orbiter will be secured and the orbiter shuttle will proceed with countdown and liftoff. (see Fig. 3.2)

Block 3.3.1 Verify Payload Systems

Access is required through Orbiter cabin to Spacelab to top-off LN₂ and load live specimens on-board. Also, access to payload bay areas required for hydrazine propellant loading.

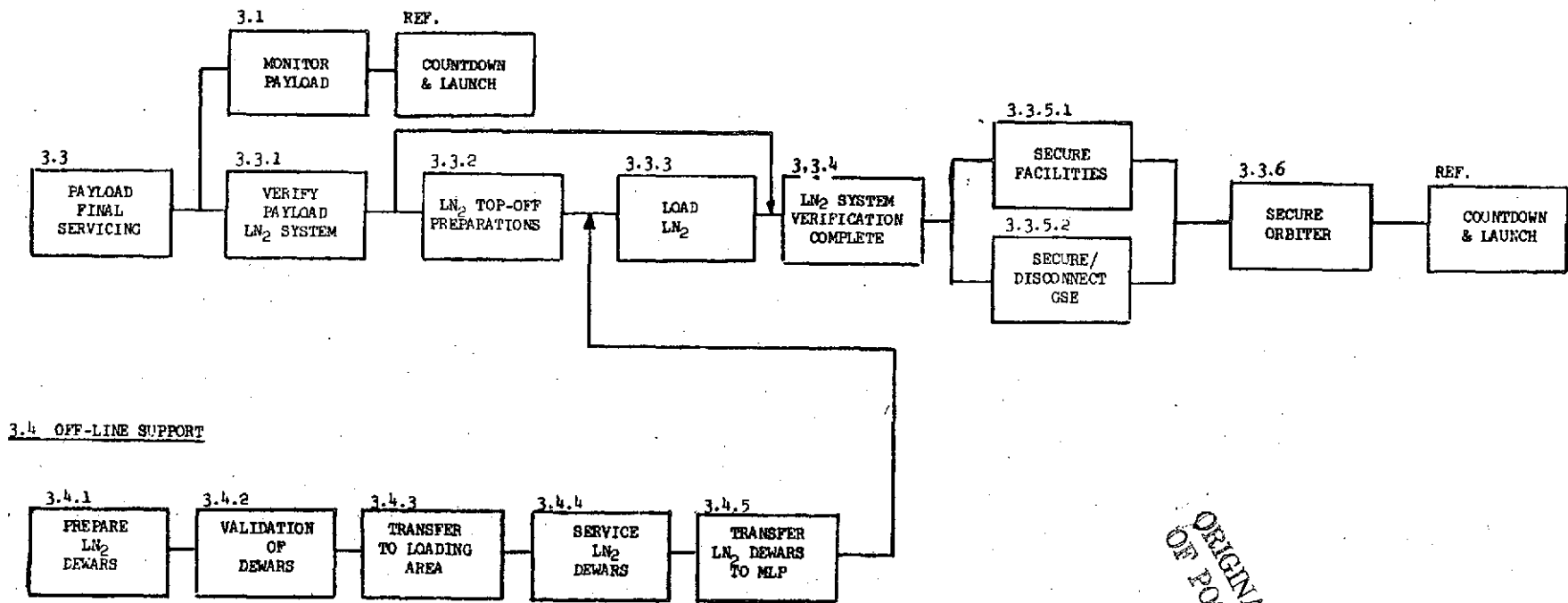

ORIGINAL PAGE IS
OF POOR QUALITY

ACTIVITY 3.3 FINAL PAYLOAD SERVICING

Figure 3.2

Facility Requirements

- o Fluids - LN₂, GN₂, Hydrazine Propellants
- o Power - 110VAC, 400Hz, 3Ø, 0.5KW
- 28VDC, 1.0KW
- o Data Processing - via Orbiter Ground Link
- o Monitoring LPS

Support Requirements

- o None

Block 3.3.2 Final Servicing Preparations

Install/connect GSE servicing equipment to payload in preparation for loading LN₂.

Facility Requirements

- o Payload changeout room
- o Power - 110VAC, 400Hz, .5KW, 3Ø
- 28VDC, 1.0KW

Support Requirements

- o GSE - TBD
- o GSE - LN₂ Dewars
- o GSE - Integrated Electronic
- o Safety

Block 3.3.3 Load LN₂

With the arrival of the LN₂ dewars, connect the dewars to servicing GSE and proceed to load LN₂.

Facility Requirements

- o Monitoring LPS
- o Data Processing - via Orbiter Ground Link
- o Power - 110VAC, 400Hz, .5KW, 3Ø
- 28VDC, 1.0KW
- o Fluids - LN₂, Hydrazine Propellant

Support Requirements

- o Safety

Block 3.3.4 Final Servicing Verification Complete

The LN₂ system monitoring check was performed, serviced and completed.
The area is safe for loading live specimens.

Facility Requirements

- o Monitoring LPS
- o Data Processing - via Orbiter Ground Link
- o Power - 110VAC, 400Hz, 0.5KW, 3Ø
- 28VDC, 1.0KW

Support Requirements

- o Medical Baseline and Preparation Lab
- o Life Support and Protective System Prep Lab
- o Specimen and Sample Transfer Units
- o Specimen Holding Unit (Transfer and Loading Spacelab)
- o Safety
- o Transportation
- o Handling Fixtures/Slings

Block 3.3.5.1 Secure Facilities

Secure all facilities on MLP in support of payload monitoring, verification checks and servicing.

Facility Requirements

- o None

Support Requirements

- o None

Block 3.3.5.2 Secure/Disconnect GSE

Secure/disconnect all GSE on MLP, Payload Changeout Room, used in support of payload monitoring, verification checks and servicing.

Facility Requirements

- o None

Support Requirements

- o Transportation - TBD
- o Safety

Block 3.3.6 Secure Orbiter

Payload bay, payload/experiments are now completely secured and Launch Operations can proceed toward countdown and liftoff.

Facility Requirements

- o None

Support Requirements

- o None

Block 3.4 Off-Line Support

Off-line Support is any activity required for support of verification, servicing, monitoring, etc. that will be used to support the processing of the payload through Launch Operations.

Block 3.4.1 Prepare LN₂ Dewars

The preparations is an off-line activity for top-off of LN₂ on payload during final servicing.

Includes disassembly/assembly of dewars for cleaning, calibration and proofing of hoses.

Facility Requirements

- o Mech Lab with laminar flow bench
- o Clean Lab
- o Calibration Lab

Support Requirements

- o Transportation - TBD

Block 3.4.2 Validation of Dewars

Functional test of dewars prior to servicing.

Facility Requirements

- o Mech Lab
- o Power - TBD

Facility Requirements (continued)

- o Fluids - GN₂, LN₂

Support Requirements

- o None

Block 3.4.3 Transferring Dewars to Area for LN₂ Loading

Facility Requirements

- o None

Support Requirements

- o Transportation - TBD

Block 3.4.4 Service LN₂ Dewars

Configure LN₂ dewars, load, and verify dewars are ready to support top-off of payload experiment.

Facility Requirements

- o Fluids - LN₂, GN₂
- o Power - TBD

Support Requirements

- o None

Block 3.4.5 Transfer LN₂ Dewars to MLP

Upon completion of servicing transfer LN₂ dewars to MLP to support top-off of payload/experiment.

Facility Requirements

- o None

Support Requirements

- o Transportation - TBD

Block 3.6 Typical Off-Line Maintenance - *Experiment/Payload/GSE

The off-line maintenance for experiment, payload, and GSE in direct support of the experiment is the responsibility of the experimenters. The maintenance is performed in the support facilities, required for trouble-shooting, repair and verification, as defined in Facilities Requirements for their particular experiment/payload/GSE. A typical off-line maintenance flow is shown in Figure 3.3

Block 3.6.1 Transfer to Repair Facility

Initial step in off-line maintenance is to transfer experiment/payload/GSE to specific facility required to support maintenance of anomaly.

Facility Requirements

- o Materials Analysis Lab
- o Film Lab
- o Battery Lab and Storage
- o Clean Lab
- o Zoology Lab
- o Calibration Lab
- o Biology Lab
- o Radiological Lab
- o Vacuum Chamber
- o Elect Lab
- o Machine Shop
- o Data Processing
- o Mech Lab

Support Requirements

- o Biology Lab - ^{of} Portable at Launch Site
- o Transportation
- o Cranes
- o Handling Fixtures
- o Forklifts.

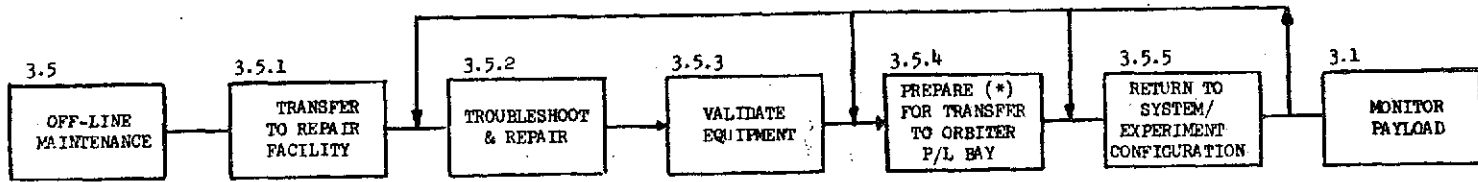

ORIGINAL PAGE IS
OF POOR QUALITY

*
TYPICAL EXPERIMENT/PAYLOAD/GSE - OFF-LINE MAINTENANCE FLOW

FIGURE 3.3

Block 3.6.2 Troubleshoot and Repair

Perform all steps necessary for trouble-shooting and repair of Spacelab/
experiment/payload/GSE anomaly.

Facility Requirements

- o Battery Lab and Storage
- o Cleaning Lab
- o Zoology Lab
- o Calibration Lab
- o Biology Lab
- o Film Lab
- o Data Processing
- o Radiological Lab
- o Vacuum Chamber
- o Elect Lab
- o Mech Lab
- o Materials Analysis Lab

Support Requirements

- o Logistics Spares

Block 3.6.3 Validate Equipment

Performance of test to verify anomaly has been repaired and experiment/
payload/GSE is ready to support mission.

Facility Requirements

- o Power - TBD
- o Fluids - TBD
- o Gases - TBD

Support Requirements

- o Test Equipment - TBD
- o Support GSE - TBD

Block 3.6.4 Prepare (*GSE) for Transfer to Orbiter Payload Bay

Perform all steps necessary to prepare *experiments, payload/GSE for transfer back to Orbiter Spacelab Payload Bay, while still maintaining integrity of experiment.

Facility Requirements

- o Power - TBD
- o Fluids - TBD
- o Gas - TBD

Support Requirements

- o Transportation
- o Forklifts
- o Handling Fixtures
- o Biology Lab - Portable at Launch Site

Block 3.6.5 Return to System/Experiment Verification

Reinstall experiment payload, GSE back to configuration to support mission. Verify electrical/mechanical interfaces as required, and verify mission support capabilities of system.

Facility Requirements

- o Power - TBD
- o Fluids - TBD
- o Gas - TBD
- o Data Processing
- o Monitoring LPS

Support Requirements

- o TBD

Block 3.7 Typical - Payload/Orbiter - Maintenance Flow

The Orbiter Support System for Payloads are Orbiter (KSC) responsibility. If an anomaly occurs between the interfaces, such as in the Data Processing System or Environmental System, the appropriate Orbiter (KSC) representative would be

Block 3.7 (continued)

notified and KSC would proceed with resolving anomaly. After resolution, interfaces would be verified to determine if ~~new~~ ^{now} payload is ready to support its mission in orbit.

Facility Requirements

- o KSC Responsibility

Support Requirements

- o KSC Responsibility

Scenario - Activity

Block 4.0 Post Landing Operations

With the Orbiter hard mounted in the OPF, the Orbiter Support Systems are switched to facility services and preparation for safing and removal of payload elements begins. Safing completed, the time critical items are removed, and the GSE processing for removal of payload doors and payload proceed until payload is securely mounted on transporter and is transported to the Payload Post-Mission Processing Area.

Block 4.1 Switch to Facility Services and Safe Payload

The Orbiter Support Systems are switched to facility services; such as, power, cooling, and instrumentation. Purge and Dry Payload elements (as applicable) commences until payload is environmentally safe for personnel access. The switch over to Payload Ground Monitoring, if applicable, is also verified during this activity.

Block 4.1.1 Payload Support System Verification

The payload bay area has been purged and the change over to facilities for power, cooling, instrumentation for ground monitoring has been completed and verified operational.

Facility Requirements

- o Power - 110VAC, 400Hz, 1.0KW, 3 ϕ
 - 28VDC, 1.0KW

Support Requirements

- o None

Block 4.1.2 Payload Environment Safe

A verification by safety that the payload area is environmental safe for personnel access.

Facility Requirements

- o Power - 110VAC, 400Hz, 1.0KW, 3 ϕ
 - 28VDC, 1.0KW

Support Requirements

- o Safety

Block 4.2 Remove Time Critical Flight Experiments

The payload bay area safe for access, the experimenters can perform the tasks necessary for the removal of time critical flight experiments; such as, film and live specimens from Spacelab. Proceed to conduct post mission experiments.

Block 4.2.1 Place Items in Applicable Containers/Carriers

Upon access to payload, the experimenters remove the time critical flight experiments; such as, film, and place them in applicable containers/carriers.

Facility Requirements

- o Power - 110VAC, 400Hz, 1.0KW, 3 ϕ
- 28VDC, 1.0KW

Support Requirements

- b None

Block 4.2.2 Remove from Orbiter Payload Bay

The Time Critical Flight Experiments are ready for removal from Orbiter Payload Bay, and are transferred to the appropriate processing area.

Facility Requirements

- o Power - 110VAC, 400Hz, 1.0KW, 3 ϕ
- 28VDC, 1.0KW

Support Requirements

- o Transportation
- o Dark Room

Block 4.3 Open Payload Bay Doors and Install Payload GSE

After the thermal protection system, the Payload Bay Doors are removed and the manipulator arm deployed, the experimenter is responsible for installation of payload bay access stands.

Block 4.3.1 Install Payload Bay Access Stands

The experimenter install payload access stands, as required for removal of payload from Orbiter Payload Bay.

Facility Requirements

- o Power - 28VDC, 1.0KW

Support Requirements

Aux Equipment - Environmental Control - TBD

Block 4.4 Remove Payload

The removal of Payload includes all the tasks; such as, attaching payload handling GSE, demating of the Payload/Orbiter interfaces, the removal of access stands, and finally the removal from payload bay and placement on payload transporter/handling fixture.

Block 4.4.1 Attach Payload Handling GSE

The Payload Handling GSE; such as, slings are now moved into place and connected to lifting points on payload.

Facility Requirements

- o Power - 28VDC, 1.0KW
- o Crane - 25,000 lbs. capability

Support Requirements

- o Handling Fixtures/Slings
- o Aux Equip - Environmental Control - TBD

Block 4.4.2 Demate Payload/Orbiter Interfaces

The Payload/Orbiter Interfaces are disconnected and the payload is inspected for approval for removal from Orbiter.

Facility Requirements

- o Power - 28VDC, 1.0KW
- o Crane - 25,000 lbs.

Support Requirements

- o Handling Fixtures/Slings
- o Aux Equipment - Environmental Control - TBD

Block 4.4.3 Remove Access Stands from Payload Bay

The experimenters remove the access stands in order to clear the payload bay area for removal of payload.

Facility Requirements

- o None

Support Requirements

- o Handling Fixtures/Slings

Block 4.4.4 Remove Payload from Payload Bay

The Payload is lifted from the payload bay and installed/mounted on the payload transporter/handling fixture.

Facility Requirements

- o Power - 28VDC, 1.0KW

- o Crane - 25,000 lbs.

Support Requirements

- o Handling Fixtures/Slings
- o Safety
- o Clean Room - ^{or} Portable
- o Aux Equipment - Environmental Control - TBD
- o Pallet - Handling Fixture
- o Spacelab - Handling Fixture

Block 4.5 Move Payload to Post Mission Processing Area

After payload is installed/mounted on transporter verify payload monitoring system is operating, if applicable, and payload is secure and proceed with transfer to Post Mission Processing Area.

Block 4.5.1 Verify Payload Secure on Transporter

Experimenter verifies payload monitoring system is operational, and payload is securely mounted on transporter.

Facility Requirements

- o Power - 28VDC, 1.0KW

- o Crane - 25,000 lbs.

Support Requirements

- o Clean Room/Enclosure - Portable
- o Aux Equipment - Environmental Control - TBD

Block 4.5.2 Move Payload to Post Mission Processing Area

With payload secure in transporter, proceed to Post Mission Processing Area.

Facility Requirements

- o Power - 28VDC, 1.0KW

- o

Support Requirements

- o Clean Room/Enclosure - Portable
- o Transportation - Tractor
- o Aux Equipment - Environmental Control - TBD
- o Security
- o Safety

ORIGINAL PAGE IS
OF POOR QUALITY

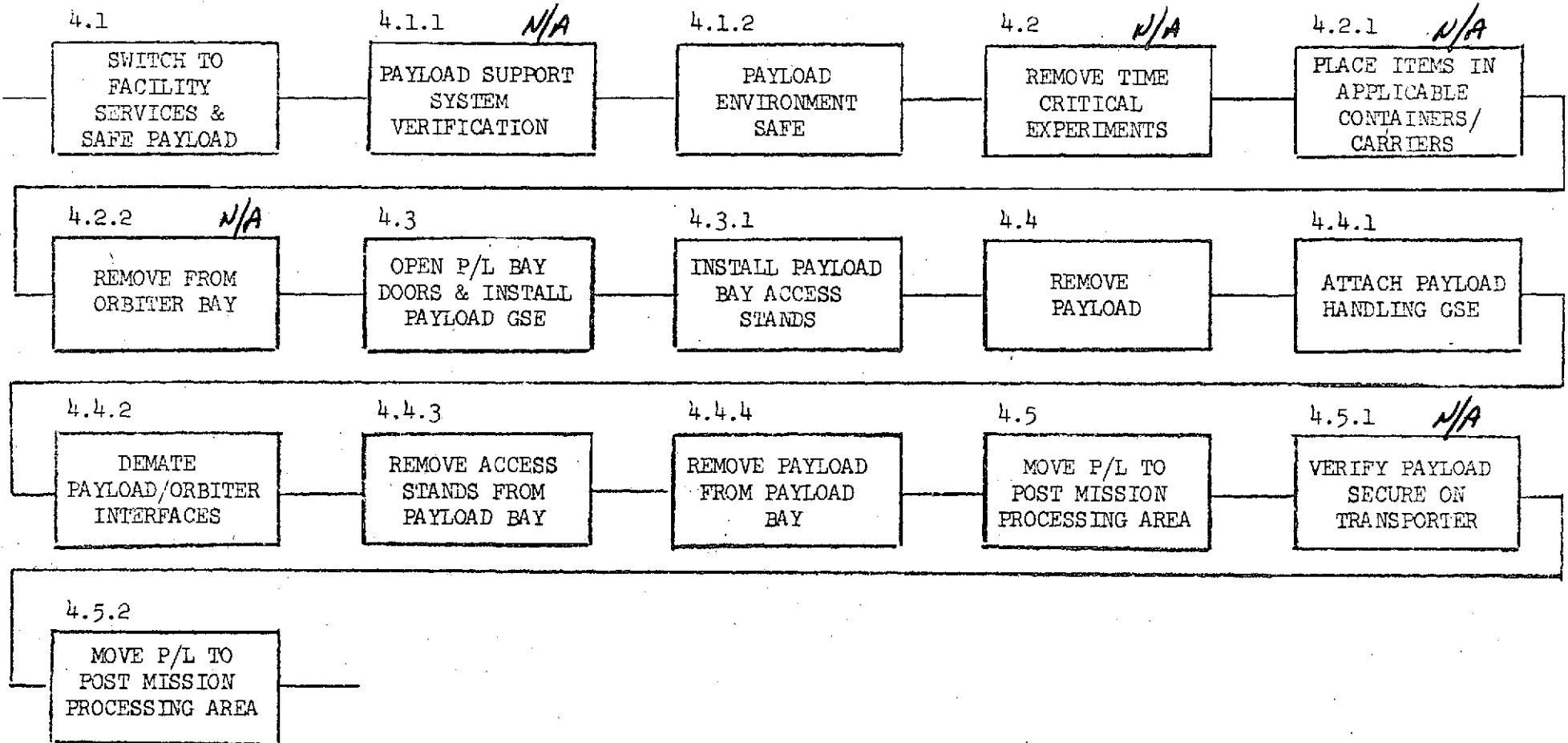

5.0 Post Mission Processing - Mission #14

The activities contained within this functional block defines the processing required following flight and prepares the various payload elements for return to their post mission sites. Figure 2.5-1 graphically depicts this flow.

The following assumptions were made in defining this flow:

- o Vehicle has been safed and verified.
- o All pressures have been vented to nominal values.
- o All lines have been purged, padded, and capped.
- o All exposed electrical connectors have been capped.
- o All other activity in Functional Block 4.0 has been completed.

5.1 Inspect Payload

Conditions: Spacelab has been delivered to the Premission Processing Facility and wiped down in the airlock.

5.1.1 Position payload and access GSE in the proper area.

5.1.2 Remove all protective covers and/or panels to gain visual access to all payload elements.

5.1.3 Visually inspect all payload elements for physical damage and document the discrepancy.

5.1.4 Remove any remaining flight data and deliver to the proper agency.

5.1.5 Clean payload elements as required.

Support Requirements for Functional Block 5.1

Facilities

Floor Space 840 sq. ft. (30 x 28)

O/H crane 10 ton capacity

Ground Support Equipment

Work/Access stands set

Handling equipment, covers

Support

Crane Operator

Logistics

Procedures

FIG 2.51

POST MISSION PROCESSING

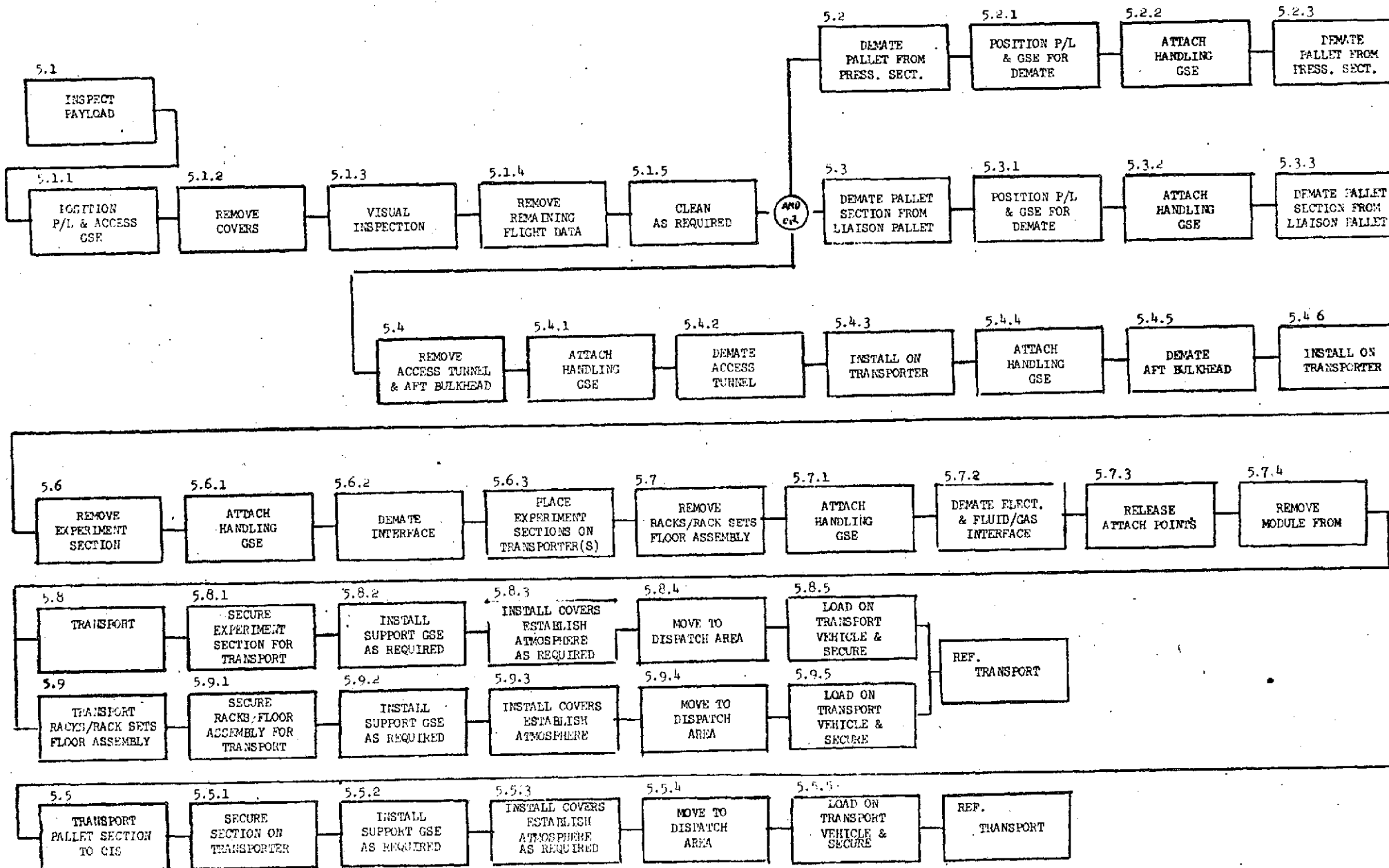

5.4 Remove Access Tunnel and Aft Bulkhead from Pressurized Section

Conditions: Removal of the access tunnel and aft bulkhead may proceed following cleaning and inspection.

5.4.1 Attach handling GSE and unlatch mechanical attachments between tunnel and pressure section.

5.4.2 Demate access tunnel, inspection seal surface on tunnel and pressure section, install protective covers.

5.4.3 Install tunnel on transporter, install transport protective cover(s), establish proper atmosphere for move to ready storage or refurbishment.

5.4.4 Attach handling GSE to aft bulkhead and unlatch attach points between bulkhead and pressure section.

5.4.5 Demate aft bulkhead, inspect each side of sealing surface, install protective covers.

5.4.6 Install bulkhead on transporter, install protective cover(s), establish proper atmosphere for move to ready storage or refurbishment.

Support Requirements for Functional Block 5.4

Facilities

Same as Block 5.1 plus prime mover.

Ground Support Equipment

Handling equipment, tunnel and bulkhead transporters, tunnel and bulkhead GN₂ regulating unit protection set, seals.

Support

Prime mover operator.

Logistics

Procedures.

5.6 Remove Experiment Section

Conditions: Aft bulkhead has been removed and protective cover(s) is in place.

5.6.1 Attach handling GSE and emplace access ramps and stands.

5.6.2 Demate all fluid/gas and electrical interface connections. Release mechanical attach points. Remove experiment section from the pressure section. Cap lines and plugs.

5.6.3 Position experiment sections on transporter.

5.7 Remove Racks/Rack Sections and Floor Assemblies

Conditions: Aft bulkhead has been removed and experiment sections have been removed.

5.7.1 Attach handling GSE and emplace access ramps and stands.

(Access ramps and stands may remain from preceding step.)

5.7.2 Demate all fluid/gas and electrical interface connections. Release mechanical attach points. Remove assemblies from the pressure section. Cap all lines and plugs.

5.7.3 Position racks/rack sets and floor assembler on transporters.

Support Requirements for Functional Blocks 5.6 and 5.7

Facilities

Same as 5.1.

Ground Support Equipment

Handling equipment, experiment sets

Transporter, experiment section

Containers, racks/floor assemblies.

Logistics

Procedures

5.8 Transport Experiment Section

Conditions: Units have been removed from the pressure sections and are in place on their transporters.

5.8.1 Secure experiment section to the transporter attach points.

5.8.2 Install transporter support GSE.

5.8.3 Install cover(s), purge and establish proper atmosphere for transport.

5.8.4 Move transporter with the experiment sections to shipping area.

5.8.5 Load transporter into transfer vehicle tiedown and secure. Verify all monitoring devices operational.

5.9 Transport Racks/Rack Sets and Floor Assemblies

Conditions: Unit(s) has been removed from the pressure section and is in place on the transporter(s).

5.9.1 Secure units to the transporter attach points.

5.9.2 Install transporter support GSE.

5.9.3 Install cover(s) purge and establish proper atmosphere for transport.

5.9.4 Move transporter(s) with racks/rack sets/floor assemblies to shipping area.

5.9.5 Load transporter(s) onto transfer vehicle tie down and secure. Verify all monitoring devices operational.

5.9.5.1 Secure all GSE and return to storage area.

Support Requirements for Functional Blocks 5.8 and 5.9

Facilities

Same as Block 5.5 plus prime mover(s).

Ground Support Equipment

Same as Block 5.7

Tie down sets

Support

Vehicle operator(s)

Logistics

Procedures

Transportation

Warehousing floor space TBD

LIFE SCIENCES SHUTTLE LABORATORY (LSSL)

LS-09-S

Difference Between

Launch Site Facility Requirements Data Sheet (Functional)

Revision A - Dated 8/31/74

and

GAC Data

The differences in launch site requirements are included in the following pages. The Data Sheet information is shown in parenthesis and followed by GAC data and logic basis. Requirements solely generated by GAC and not reflected in the Data Sheets have not been duplicated

1.4 Receiving and Inspection

A. Payload Processing Area

<u>LENGTH (ft)</u>	<u>WIDTH (ft)</u>	<u>MIN HEIGHT (ft)</u>
(25)	(20)	(20)

- o 38 ft. long, 14 ft. wide, and 8 ft. high for receiving/inspection of four racks/conssoles and the centrifuge in series.

<u>TEMP(°K)</u>	<u>RELATIVE HUMIDITY(%)</u>	<u>CLEANLINESS</u>
(298±3=77°F±6)	(50±10)	(100K)

- o Study lists no requirements for these parameters. Data Sheet #S-24 (Ground Environmental Limits) lists all data as TBD.

B. Payload Peculiar Equipment

(200 ft.²)

- o 24 ft. long, 14 ft. wide, 4 ft. high for two electrical LSSL GSE racks.

1.6 Install Racks/Rack Sets Including Isotope Vault

AND

1.7 Install Centrifuge

A. Payload Processing Area

<u>LENGTH (ft)</u>	<u>WIDTH (ft)</u>	<u>MIN HEIGHT (ft)</u>
(25)	(25)	(20)

- o 60 ft. long (Spacelab = 37 ft., loading/unloading assembly = 20 ft., clearance = 3 ft.), 21 ft. wide (Spacelab = 15 ft., clearance = 3 ft. each side), and 20 ft. high (Spacelab and stand - 18 ft., clearance = 2 ft.).

<u>TEMP(°K)</u>	<u>RELATIVE HUMIDITY (%)</u>	<u>CLEANLINESS</u>
(298±3=77°F±6)	(50±10)	100K

- o Study lists no requirements for these parameters. Data Sheet #S-24 (Ground Environmental Limits) lists all data as TBD.

B. DC Power

<u>VOLTS (DC)</u>	<u>POWER (KW)</u>
(28)	(2.0)

1.7B (continued)

- o Study lists no requirements for power during the rack/console/centrifuge installation activity. Data Sheet #S-23 (Ground Facility Requirements), and Data Sheet #S-24 (Ground Environmental Limits) contain no LSSL monitoring/equipment operating requirements. There are power requirements for the Life Sciences Preparation and Post-Flight Receiving Laboratories, as well as monitoring requirements at Launch Pad/Lift-off (Data Sheet #S-19); however, the installation of equipment in the Spacelab does not involve these power requirements.

C. Special Handling

(N/A)

- o The Study uses the "Loading/Unloading Concept Rack Assembly" described in the "Spacelab, Preliminary Technical Description" document, page 46. In addition, the Study identifies an overhead crane, 2000 lbs. capacity, for installing the centrifuge.

1.9 Install Crew Access Tunnel

(Data Sheet includes requirements for temperature, relative humidity, and cleanliness class. In addition, Note 1 states these environmental requirements refer to storage and assembly areas which correspond to Spacelab internal environment to be maintained once Spacelab is assembled.

- o Study assumes that tunnel installation is not an experiment-related task, that the installation will be performed by launch site personnel (who process all Spacelab elements except pallets-this is a Study ground rule), thus Study does not include Block 1.9 activities for support/facility requirements.

As a comment, however, the basis for the environmental requirements is unknown. During Block 1.9 activities, there remains downstream the activities of Block 1.13 (Final Integrated Systems Test) and Block 1.14 (Service non-time critical items). Thus, it appears that

1.9 (continued)

at this stage in the processing, there are no specimens aboard, and Level B data for the hardware in a non-operating ground environment is TBD.

1.13 Final Integrated Systems Test

A. Payload Processing Area

(Data Sheet includes requirements for temperature, relative humidity, and cleanliness class. In addition, Note 1 is referenced. Please see paragraph Block 1.9 above.)

- o Study includes no environmental requirements for LSSL hardware. Please see paragraph Block 1.9 above.

B. DC and AC Power

Volts (DC) = (28)

Power (KW) = (2.0)

Volts (AC) = (115)

Hertz = (400)

Phase = (3)

Power (KW) = (1.5)

- o Study includes no power requirements for Final Integrated Systems Test. The Study considers this test to be a verification of the interface between the Spacelab and the Orbiter, using the Orbiter Simulator to provide the Orbiter functions. The LSSL requirements would have been integrated previously with those of the Spacelab, would not be broken out separately since they would be misleading, and are minor in comparison to the demands made on the Orbiter Simulator (or Orbiter) by the Spacelab. Thus, Data Sheet #S-15 lists 28VDC off-duty = 2688W, on-duty = 2826W at LSSL-Spacelab interface during Mission Operations which appears not applicable to Block 1.13 activities since racks/consols centrifuge are not being operated.

1.13B (continued)

The requirement for 115VAC may be derived from Data Sheet #S-23 (Ground Facility Requirements) which lists 115 VAC, and 28 VDC, 20-30 KW, for Life Sciences Preparation and Post-Flight Receiving Laboratories, the processing of which is not contained in the Study.

1.14 Service Non-Time Critical Items

A. Payload Processing Area

(Data Sheet includes requirements for temperature, relative humidity, and cleanliness class.)

- o Study includes no requirement. Please see paragraph Block 1.9 above.

B. Fluids

(Data Sheet includes requirements for Media, Press, Flow Rate, Temp, and Cleanliness Spec.)

- o Study includes no facility requirements, since LSSL Level B data does not define non-time critical service items. It is noted that MSFC Spec 234 is called out for GN₂, O₂, CO₂, and H₂, and the Study assumes these items would be furnished by the user (LSSL) rather than impose them on the Launch Site Facilities. In addition, LN₂ servicing is listed as a non-time critical item which appears inappropriate.

1.16.1 Weigh Spacelab

(Data Sheet contains payload processing area and special handling requirements for this activity.)

- o Study does not contain this block in the functional flow processing. However, the comment is offered that a Weight and C.G. Test would be performed by launch site personnel and would not involve experiment-related activities.

1.17 Move to OPF - Secure GSE

(Data Sheet has environmental requirements for Temp, Relative Humidity, and Cleanliness Class.)

1.17 (continued)

- o Study contains no environmental requirements for LSSL during move from PFF to OFF. Please see paragraph Block 1.9 above.

LAUNCH SITE FACILITIES REQUIREMENTS (FUNCTIONAL)

2.0 Orbiter/Payload Mate and Integrate (Life Science Shuttle Laboratory)

2.1 Install Payload in Orbiter Payload Bag

o Area Requirements: (25'L x 25' W x 60'H)

The Space lab dimensions, as given in the ERNO description book are 23'L x 13'D. The 25' length identified on the data sheets would not allow for work stands or adequate end access. Allowing for stands and access aisles (4' work stands and 6' aisles) plus an additional 10' aft of the Lab for work benches, roll arounds etc., the area would be $23 + 2(4) + 2(6) + 10$ X $13 + 2(4) + 2(6)$ or 53' long x 33' wide. The height of 60' is adequate for the mating operation.

o Environment: 2.1 through 2.5 (Temp $298 \pm 3^\circ\text{K}$, Humid. $50 \pm 10\%$ and Cleanliness Class 100,000)

This requirement appears logical for the mating operation, however, note  states External Environment N/A. GAC feels the facility environment should meet the same specification to allow open access to the Spacelab interior without special precautions being necessary to preserve the interior condition.

o Fluid Requirements: 2.1 through 2.5

N/A

Although from the Level B descriptions no firm requirements are discernible in this function, future, more detailed procedures for final closeout and Integrated Test may dictate the servicing of various fluids and gases during this portion of the pre-launch flow. It is recommended that early effort be placed on solidifying procedures.

LAUNCH SITE FACILITY REQUIREMENTS DATA SHEET (FUNCTIONAL)

Block 3.0 Prelaunch and Launch Operations

Block 3.1 Monitor Payload (60 hours)

Function - The LDEF is a "passive" experiment which has no monitoring requirements. Therefore the time estimate of 60 hours should be deleted.

Block 3.2 Launch Readiness Verification/Orbiter Cabin Closeout (8 hours)

During this period, an operational check to verify the monitoring capabilities of the A-9 equipment and the recorder located in the OBSS is recommended. Facility requirements to support this verification are as follows:

Power - 28VDC, (TBD)KW

Other - Monitor - LPS

- Access required to OBSS

- Data Processing via Orbiter Data Computer

Block 3.3 Payload Final Servicing (4 hours)

Function - The LDEF is a "passive" experiment which has no final servicing requirements. Therefore, the time estimate of 4 hours should be deleted.

Block 3.4 Off-line Support (Not on Functional Data Sheets)

On a contingency basis, the LDEF should have the capabilities to perform any maintenance, repair or checkout to support the launch mission. Although the requirement is on a contingency basis, the following requirements should be considered as part of the physical requirements.

Power - TBD

Fluids - TBD

LAUNCH SITE FACILITY REQUIREMENTS (FUNCTIONAL)

Block 4.0 Post Landing Operations Life Science Shuttle Lab

No payload activity, except refrigerator power required until:

Block 4.4 Remove Payload

o Area Requirements: (N/A)

When the Lab is removed from the Orbiter Bay, it must be positioned on or in a transport vehicle, space will be required for this operation. Based on the same logic used for function 2.0, the area required would be 53' long x 33' wide; the hook height required for the demate would be 50' minimum.

o Special Handling N/A

To remove the LSSL from the payload bay requires an O/H crane of 11 tons capacity.

No other recommended changes.

LAUNCH SITE FACILITIES REQUIREMENTS (FUNCTIONAL)

LIFE SCIENCE SHUTTLE LABORATORY

Block 5.0 Post Mission Processing

o Area Requirements (25'long x 20'wide x 20'high)

The space lab dimensions, as given in the ERNO description book are 23'long x 13'deep. The area requirements are inadequate and would not allow for work stands or adequate end access. Allowing for stand and access aisles, work stand, roll arounds, etc., the area required should be a minimum of 53'long x 33'wide. The height of 20' is adequate for removal of the space lab from payload transporter.

LIFE SCIENCES SHUTTLE LABORATORY (LSSL)

LS-09-S

Differences Between

Launch Site Facility Requirements Data Sheet (Physical)

(Revision A - dated 8/31/74)

and

GAC Data

The differences in launch site requirements are included in the following pages. The Data Sheet information is shown in parenthesis and followed by GAC data and logic basis. Requirements solely generated by GAC and not reflected in the Data Sheets have not been duplicated.

LAUNCH SITE FACILITY REQUIREMENTS DATA SHEET (PHYSICAL)

Block 3.0 Prelaunch and Launch Operations

A. Storage Area - Non-Applicable for this functional flow. Storage requirements are defined in functional activities 1.0 and 5.0.

B. Office

o Number Engineers/Scientists

(20)

During this activity, engineers are only required for the verification checks, and therefore, minimum space would be required in launch area. Assume two engineers at launch site, and remaining support engineers in PPF. Total (6).

o Number Technicians

(20)

During this activity, technicians are only required for the verification checks, and therefore, minimum space would be required in launch area. Assume requirement for four technicians at launch site and remaining support technicians in PPF.

Total (8).

22

LAUNCH SITE FACILITY REQUIREMENTS (PHYSICAL)

Block 4.0 Post Landing Operations (Life Science Shuttle Lab)

- o Storage Area: (400 ft²)

Since no storage function is defined, no storage requirement exists.

There are no other recommended changes.

LAUNCH SITE FACILITY REQUIREMENTS (PHYSICAL)

LIFE SCIENCES SHUTTLE LABORATORY

Block 5.0 Post Mission Processing

For comments refer to Activity 1.0 (Physical).