

**NASA TECHNICAL  
MEMORANDUM**

NASA TM X-62,403

NASA TM X-62,403

(NASA-TH-X-62403) STOL TERMINAL AREA  
OPERATING SYSTEMS (AIRCRAFT AND ONBOARD  
AVIONICS, ATC, NAVIGATION AIDS) (NASA) 50 p  
HC \$3.75 CACL 01B

N75-21254

Unclas  
18615  
G3/03

**STOL TERMINAL AREA OPERATING SYSTEMS**  
(Aircraft and Onboard Avionics, ATC, Navigation Aids)

Clifford Burrous, Heinz Erzberger  
Norman Johnson, and Frank Neuman

Ames Research Center  
Moffett Field, Calif. 94035



November 1974

1. Report No. TM X-62,403	2. Government Accession No.	3. Recipient's Catalog No.	
4. Title and Subtitle STOL TERMINAL AREA OPERATING SYSTEMS (Aircraft and Onboard Avionics, ATC, Navigation Aids)		5. Report Date	
		6. Performing Organization Code	
7. Author(s) Clifford Burrous, Heinz Erzberger, Norman Johnson, Frank Neuman		8. Performing Organization Report No. A-5829	
		10. Work Unit No. 768-81-03-02	
9. Performing Organization Name and Address NASA Ames Research Center Moffett Field, Calif. 94035		11. Contract or Grant No.	
		13. Type of Report and Period Covered Technical Memorandum	
12. Sponsoring Agency Name and Address National Aeronautics and Space Administration Washington, D.C. 20546		14. Sponsoring Agency Code	
		15. Supplementary Notes	
16. Abstract <p>STOL aircraft will be required to fly special flight paths to operate in restricted airspace in order to avoid CTOL airways and thus effectively provide congestion relief. Reliable transportation will require aircraft systems and operational procedures to accomplish this safely in all types of atmospheric conditions and weather while using available navigation aids. Operational procedures and systems onboard the STOL aircraft which are required to obtain acceptable performance under these constraints are the subject of this report. Results of simulation and flight investigations to establish operational criteria are presented.</p>			
17. Key Words (Suggested by Author(s)) Microwave landing system STOL aircraft Air traffic control Guidance; Navigation		18. Distribution Statement  Unclassified - Unlimited  STAR Category 03	
19. Security Classif. (of this report) Unclassified	20. Security Classif. (of this page) Unclassified	21. No. of Pages 50	22. Price* \$4.25

## List of Symbols

STOL	Short Takeoff and Landing
ATC	Air Traffic Control
NASA	National Aeronautics and Space Administration
FAA	Federal Aviation Administration
CTOL	Conventional Takeoff and Landing
TACAN	Tactical Air Navigation
VOR/DME	Velocity Ominrange/Distance Measuring Equipment
EL <sub>1</sub>	Elevation (Coarse Measurement)
EL <sub>2</sub>	Elevation (Fine Measurement)
FAA	Federal Aviation Agency
IFR	Instrument Flight Rules
ICAO	International Civil Aviation Organization
RTCA	Radio Technical Committee for Aeronautics
SC-117	Special Committee 117 of the RTCA
CAT I	Category one operations with 61 m Decision Height
CAT II	Category two operations with 30.5m decision height
CAT III	Category three operations with guidance to touchdown
Hz	Hertz (cycles per second)
D configuration	An MLS operational configuration (reference 10)
I configuration	An MLS operational configuration (reference 10)
2D RNAV	Two Dimensionalradion navigation
3D RNAV	Three Dimensional Radio Navigation
4D RNAV	Three Dimensional +Time Radio Navigation
$\Delta D$	Spacing Error
$\Delta t$	Time Error
$v_i$	Initial Approach Speed

$V_f$	Final approach speed
$t$	Time
$x, y, z$	Position coordinates (longitudinal, lateral and vertical respectively)
MODILS	Modular Instrument Landing System (developed experimental system for STOL by the FAA)
$\omega_1, \omega_2, \omega_3$	Filter Gains for the algorithm developed for combining navigation data
$2\sigma$	Designates an error probability of 97 percent
Az	Azimuth
A/C	aircraft
GND	Ground
$\theta$	Pitch Attitude
$\phi$	Roll Attitude
$\psi$	Yaw Attitude
$a_{xb}$	longitudinal acceleration (body axis)
$a_{yb}$	lateral acceleration (body axis)
$a_{zb}$	vertical acceleration (body axis)
$h_b$	barometric altitude
$R_s$	DME range measurement
$E_x$	error in position
$\Delta S$	Deviation of aircraft from desired position

## STOL TERMINAL AREA OPERATING SYSTEMS

(Aircraft and Onboard Avionics, ATC, Navigation Aids)

Clifford Burrous  
Heinz Erzberger  
Norman Johnson  
Frank Neuman

Critical factors in assessing the technology requirements of STOL Transportation are the environment in which the STOL aircraft will operate (i.e. navigation aids, ATC, atmospheric conditions and weather), the operational procedures needed to safely cope with the environment, and the systems which are needed onboard to assist the aircraft and pilot to carry out these procedures, with acceptable workload. Operational procedures and systems onboard the STOL aircraft which are required to enable the aircraft to perform acceptably in its special environment are the subject of this paper.

The development of operational procedures and systems for STOL aircraft is particularly challenging because of the many modes of STOL operations which are possible:

- a) low density STOL operations including military requirements
- b) Interurban high density STOL operations into special STOL ports which are near business districts
- c) city to city operation into special STOL ports
- d) short-haul operations into major airports

Variables brought about by these operational modes are:

- a) types of runways (size and location)
- b) navigation aids which may be available
- c) size and type of STOL aircraft required
- d) sophistication and resultant cost of onboard avionics

- e) airspace availability
- f) environmental constraints

Definition of system concepts for application to a specific mode of STOL transportation will require trade-off studies to be made. Environmental impact, service, and cost are examples of factors which will be involved in these tradeoffs. Therefore, it is not possible to configure a single STOL transportation system which will satisfy general requirements and define its operational characteristics and required onboard systems. Instead, a program is needed to provide data on the performance of STOL aircraft and onboard systems over a range of operational requirements and variables. This will allow designers and operators of future STOL transportation systems to make concept decisions based on known performance. NASA has developed such a program for STOL aircraft.

This paper discusses the STOL onboard systems and operations which are being investigated by NASA to establish a data base which will provide the information needed by STOL designers and operators. First the requirements which proposed navigation aids such as the MLS place on STOL aircraft systems will be discussed. Then an aircraft system concept for terminal area operations which advocates separate STOL ATC routes and onboard 4D (time constrained) guidance computations to achieve maximum runway capacity and reduce CTOL system congestion will be described. Finally a simulation and flight program to provide a data base of information on STOL aircraft and systems as a function of various systems and operational parameters will be discussed.

## STOL Microwave Landing Systems Study

The impact of operational/functional characteristics of the new Microwave Landing System (MLS); such as accuracy, coverage, and data rates for the azimuth, DME primary elevation, and flare elevation functions; on STOL operations are being investigated by NASA. The impact on aircraft performance is being determined for representative curved flight paths through touchdown. A range of MLS errors and coverages, environmental disturbances, and navigation filtering techniques are being investigated.

The MLS/STOL accuracy requirements are determined in simulation investigations by varying the individual MLS errors and observing their effects on the aircraft dispersions at several points along the flight path, including touchdown. The MLS errors assessed include bias, random noise, and correlated noise for the MLS azimuth, elevation and DME functions. The effects of MLS errors are determined along with environmental disturbances and a range of airborne sophistication. These results are compared to tentative STOL and existing CTOL criteria, and acceptable accuracy specifications are defined.

The MLS/STOL coverage requirements are determined by varying the coverages for two representative STOL flight paths and observing the coverage needed to restabilize the aircraft after typical enroute-to-MLS transitions.

The onboard aircraft system configuration used in this investigation is based on the results of the investigations described in the next two sections. The results presented here are

obtained for a specific aircraft (C-8A Buffalo) and an onboard system which has been found to give acceptable performance over the operational flight envelope of the aircraft. The data has been obtained from simulation investigations only. However, as discussed in Section III, flight verification of the simulation investigations of aircraft and system performance has been obtained. The simulation facility used in this investigation is shown in figure 1. It consists of: a) a digital computer to simulate the aircraft, Nav aids (TACAN, VOR/DME, MLS) plus winds and turbulence; b) an avionics equipment rack containing the airborne hardware, including the airborne digital computer; c) a simulation cockpit with standard airborne instrumentation together with an advanced display and mode select system; d) an analog and logic computer simulating the control surface servos and interlock logic; and e) a data conversion interface rack which converts the digital computer data to airborne sensor signal format. The airborne hardware, advanced displays and mode and select system are described in detail in reference 1.

The MLS siting geometry used for this study is shown in figure 2. The MLS model employs a planar coordinate system and utilizes both the coarse ( $EL_1$ ) and flare ( $EL_2$ ) elevation antennas (figure 2). In the simulation computer the aircraft position coordinates are converted into MLS signals and the MLS error quantities are added. The MLS position signals are then converted to inertially reference x, y, z coordinates in the airborne computer. (The z coordinate is blended from



the coarse EL<sub>1</sub> antenna source to the flare EL<sub>2</sub> antenna source between 122 and 61 meter altitude). The runway referenced x, y, and z quantities are then sent to the navigation system.

Two typical STOL flight paths were chosen for this study - one 90° and the other 180° final turn (figure 3). The choice of flight path selection was influenced by the Federal Aviation Administration (Flight Standards Service) STOL approach procedures for future STOLports, plus NASA simulation and flight experiments with curved, descending IFR STOL approaches. Three of the ten STOLports studied in reference 2 required curved descending approaches and the maximum required turn was approximately 110° with a 1522 meter radius. The straight-in final approach distance was selected to allow for glideslope tracking stabilization and the pilot's final system checks. The flight paths were flown at a constant 72-knot approach speed so that the effects of the MLS characteristics on the longitudinal control could be more readily monitored.

One of the most difficult parts of this task is the comparison of the simulation results to known criteria. There are no FAA or ICAO specifications for any category of STOL touchdown or decision height dispersions. In lieu of such criteria, the results are compared to the existing FAA CTOL aircraft standards and tentative STOL Standards in figure 4. The criteria in figure 4 are given as 2 $\sigma$  values. With the number of parameters to be investigated in this study it was not feasible to make a sufficient number of statistical runs to obtain this level of accuracy. However, the data from the limited number of runs are sufficient to indicate the primary effects of MLS parameter changes.

Figure 5 illustrates the three basic flight-path elements which determine the azimuth horizontal coverage requirements: an initial straight segment after MLS acquisition and prior to any major maneuver, final turn radius, and a minimum straight-in final approach. Many factors influence the dimensions of these elements; however, one can see that the azimuth horizontal coverage requirement increases if: 1) the initial approach angle is increased; 2) the final turn radius is increased; or 3) the final approach distance is decreased.

The MLS must provide vertical coverage above the potential 6° to 10° STOL glideslope angles plus a reasonable margin to allow for altimeter errors and MLS vertical coverage prior to descent. The selection of the level of MLS errors that can be tolerated, in combination with all the other error sources, is difficult because the study could only assess a limited number of variables. That is, it was limited by the range of airborne sophistication, flight paths, atmospheric disturbances; a small statistical sample; a single navigation aid siting; and a single aircraft. Furthermore, the STOL decision heights, windows and touchdown criteria are still to be determined. However, even with the uncertainties, it appears that the MLS error listed in figure 6 can be tolerated in STOL terminal area operations. Two sets of accuracy requirements are listed in figure 6: (1) a Category III set for aircraft equipped with an autoland system with an inertially augmented navigation capability, and (2) a Category II set for aircraft equipped only with ordinary navigation aid filtering. The main difference between the two sets is more

stringent noise requirements for the CAT II case. In order for a single ground facility to accommodate both classes of user aircraft, a combination of the CAT II azimuth,  $EL_1$  and DME accuracy requirements, and the CAT III  $EL_2$  specification is needed. For comparison the RTCA SC-117 recommendations for a Category I and III MLS are shown. (The linear RTCA accuracy specifications have been converted to angular dimensions using typical STOL runway lengths and MLS sitings. The angles in parenthesis are based on the STOLport siting of figure 2).

The MLS coverage and data rate requirements are also summarized in figure 6. The coverage requirements were determined from the two STOL flight paths shown in figure 3. The 5.0 Hz data rate for all functions except  $EL_2$  (at 10Hz) appears to be adequate for the flight paths and range of errors evaluated. The characteristics of STOL air transportation operations are felt to require only a 10nm range rather than the proposed 20nm value.

Comparing the STOL specifications to the RTCA configurations shows that the present RTCA (CTOL) D configuration satisfies all of the STOL accuracy requirements with the exception of DME (and  $EL_2$  for CAT III). The I configuration basically satisfies the STOL coverage and data rate requirements for the flight paths assumed in this report. While these flight paths appear satisfactory for projected STOL operations, more critical paths (i.e. sharper turns, shorter final straight-in segments, etc.), could place more severe requirements on the MLS.

The levels of turbulence, as defined in figure 7 had a significant effect on longitudinal touchdown dispersions and vertical dispersions at 30.5 meter beam altitude. The addition of turbulence

causes these two dispersions to increase by a factor of approximately three. Therefore, it will be essential to measure turbulence when investigating the ability of the aircraft to control flight path using the MLS in order to assess the contribution of MLS errors to errors in flight path control.

Correlated MLS noise (with a 2-sec time constant) increases the dispersions at touchdown and 30.5 meter altitude by a factor of at least two compared to the same magnitude of uncorrelated noise. Hence, frequency content, as well as magnitude, must be included in the MLS noise specifications.

#### Impact of ATC on STOL Aircraft Systems

Congestion and delays in the CTOL system can be reduced by designing STOL air routes in the terminal area to be separate from and non-interfering with CTOL routes and by operating the STOL aircraft from separate runways or out of satellite ports. The noise impact from STOL operations can be held to an acceptable level by flying steep, curved, decelerating flight paths which minimize engine power and contact with nearby noise sensitive areas.

NASA and FAA have jointly conducted dynamic air traffic simulations of STOL operations at potential STOL port sites in order to identify guidance and air traffic control problems which such operations may engender (references 3 and 4). As expected, the unique performance characteristics of STOL aircraft permitted the design of CTOL independent flight paths, although the protected airspace around these paths was often small, requiring the STOL aircraft to track the paths with high accuracy. In these simulations, it was assumed that a large proportion of the simulated STOL traffic

had simple 2D RNAV capability, which made it possible for the aircraft to fly the specified paths, though with fairly high pilot workload. In order to conserve airspace, controllers were instructed to use speed commands rather than vectoring for spacing control. However, actual flight paths from the simulation, some of which are reproduced in figure 8, show that vectoring still was necessary and caused the complex maneuvers seen in the figure. Such maneuvers, especially if they occur at low airspeeds, are highly undesirable, not only because they result in increased airspace requirements and high pilot and controller workload, but also because they increase fuel consumption and noise.

In summary, the STOL traffic simulation demonstrated the following shortcomings of conventional terminal area control techniques:

1. Undesirable expansion of protected airspace around each route in order to allow for path stretching and vectoring maneuvers, especially in the critical region near merging points.
2. Difficult pilot and controller workload resulting from the close cooperation required between pilot and controller in order to achieve precise spacing of aircraft.
3. Higher than optimum fuel consumption and noise levels caused by vectoring commands and prolonged flight at non-optimum airspeeds.

These results provide some general guidelines for STOL aircraft and associated avionics systems. These guidelines are precise metering of arrivals, accurate and prompt execution of controller instructions, precise airborne navigation, better pilot displays and good STOL aircraft handling qualities.

Some of the difficulties encountered in the STOL traffic control can be explained if differences between CTOL and STOL control procedures are examined. One difference is that spacing of STOL traffic had to be achieved by controller generated speed commands rather than vectoring in order to conserve airspace. This caused difficulties in spacing control because speed commands are not nearly as effective as vectoring for spacing control over short distances.

Another consideration is the impact of time errors in starting the deceleration to the final approach speed. The larger the speed change from initial approach speed to final approach speed, the greater is the sensitivity of final spacing distance to errors in starting and deceleration. Under simplifying assumptions an error  $\Delta t$  in starting the deceleration causes an error  $\Delta D$  in spacing of two aircraft flying a common path according to the relationship

$$\Delta D = (V_i - V_f) \Delta t$$

where  $V_i$  and  $V_f$  are the initial and final approach speeds respectively. Using an initial approach speed of 108 m/sec for both CTOL and STOL and final approach speeds of 70 m/sec and 36 m/sec for CTOL and STOL respectively, one calculates from the ratio of the  $\Delta D$ 's that STOL final approach spacing is nearly twice as sensitive to time errors as CTOL.

The long deceleration interval also makes it more difficult for the controller to predict final spacing since before and during this interval the spacing decreases continuously. This is illustrated in figure 9, which shows the distance to touchdown vs. time

for two STOL aircraft on a common flight path. To maximize runway capacity, minimum separation must be achieved when both aircraft are flying at the same final approach speed. This occurs at about time  $t_2$ . Between  $t_1$  and  $t_2$  the first aircraft is catching up with the second aircraft. The ratio of initial to final separations is equal to the ratio of initial to final airspeeds and is typically 3:1 for STOL, but only 1.5:1 for CTOL. One can expect spacing control to increase in difficulty with this ratio.

A terminal area control concept based on 4D RNAV (3D area navigation plus time) has the potential for circumventing these difficulties. In this concept the controller work is simplified by assigning to the onboard system the responsibility to arrive at a merging point or at the runway threshold at a specified time. Aircraft spacing is therefore indirectly controlled through time spacing at one or two points. Since aircraft on approach are decelerating, a time spacing calculated from the minimum spacing and the common final approach speed will ensure that the minimum spacing is not violated at earlier points on the common path.

The airborne system is conceptually similar to a 3D RNAV system but in addition contains 4D guidance software for accurately predicting and controlling the aircraft's time of arrival at specified points on the flight path. The 4D guidance software also contains an algorithm which computes the flight path and the time to arrive at any waypoint on a specified RNAV route from any initial aircraft position, altitude, heading, and airspeed. This feature is used by

the pilot to achieve an ATC specified arrival time at the feeder fix by holding or path stretching maneuvers. A more detailed description of the airborne 4D RNAV system, together with flight test results of an experimental system flight tested at Ames Research Center is described in the next section and in reference 5.

Figure 10 summarizes the function of the airborne and ground systems and the timing of information exchanges between the aircraft and the ground in the proposed 4D RNAV environment.

Interaction between the airborne and ground systems is initiated by the pilot a few minutes prior to the aircraft's arrival at the feeder fix. At that time the pilot communicates to the approach controller his identity, preferred route, and expected arrival time at the feeder fix. From information generated by the 4D RNAV airborne system, he also communicates the range of possible flying times between feeder fix and touchdown along the preferred 3D RNAV route. Alternatively, this information could be precalculated and stored for each aircraft type and route in the ground computer, but in that case it must be updated as a function of wind velocity and shear conditions. The pilot-controller communications involved in this and other information exchanges can be carried out via the usual voice link, although a data link would be the preferred medium.



From the previous scheduling operations the ground system has available the arrival times and assigned landing time slots for all other aircraft already in the sector or previously cleared to enter it. This information together with that received from the unscheduled aircraft is processed manually by the controller or automatically by the ground computer to find the earliest available conflict-free landing time which the aircraft can attain. The controller communicates the assigned 3D route and landing time to the pilot of the aircraft who in turn enters it into the 4D RNAV system. An up-to-date estimate of the wind vector as a function of altitude could also be sent to the aircraft at this time. If the onboard system determines that the assigned time is not achievable by direct flight along the assigned route, the pilot can hold or perform path stretching maneuvers at the feeder fix until the landing time becomes feasible. Otherwise, the 4D RNAV immediately generates the guidance commands required to fly the aircraft along the desired flight path.

If all aircraft scheduled by this method were equipped with 4D RNAV systems, no further ATC commands to scheduled aircraft would normally be necessary. However, equipment failures, missed approaches or emergencies will occasionally require reassignment of landing times to some aircraft. For those aircraft, the information exchange sequence described above for unscheduled aircraft is essentially repeated.

The least understood problem in a 4D RNAV environment is that of handling a mix of 4D RNAV equipped and unequipped aircraft landing on the same runway. The ideal procedure for handling such a mix would preserve the advantages of the system for equipped aircraft without seriously penalizing unequipped aircraft or increasing controller workload. A procedure that maintains separate routes for differently equipped aircraft as close as possible to the runway is currently being investigated.

A real time simulation of the 4D RNAV concept has been developed to evaluate its potential for terminal area air traffic control of future STOL systems. Its key elements, illustrated in figure 11, are an environment, a ground system and a piloted aircraft simulation.

The environment simulation generates the pseudo traffic. Aircraft in this traffic can have full 4D RNAV capability or can be equipped with only the standard navigation systems, depending on the choice of the experimenter. The environment simulation also contains the wind model, airspace constraints, and the navigation system error model.

The ground system simulation consists of a controller display and a keyboard language for issuing controller instruction to the traffic aircraft. After addressing a particular aircraft, the controller can give it commands ranging from standard vectoring instructions to arrival time commands if the aircraft is 4D equipped.

The situation display also provides information on arrival traffic and available landing time slots to help the controller select conflict-free landing times.

The simulation also interfaces with a piloted aircraft simulation which has the capability of the guidance and navigation system described in the next section. Further details of the simulation are given in reference 6. Since the simulation includes both the human operators (controller and pilot) and the essential onboard and ground system elements involved in the terminal area operation, it can be used with confidence for developing procedures and assessing system performance of the 4D RNAV concept.

Preliminary results obtained with the simulation show that in an environment where all aircraft are equipped with 4D RNAV systems, air-ground interactions and deviations from the reference path are strongly reduced. This result is illustrated in figure 12 for the same airport and scenarios as in figure 8. On the basis of these preliminary results, the FAA has developed more refined 4D RNAV procedures which will be investigated in future simulations.

#### 4D RNAV Guidance and Navigation

The previous section pointed to the need for a 4D RNAV system onboard the STOL aircraft, and a proposed operation considering ATC constraints described which has the potential for handling STOL operations under difficult terminal area constraints. In this section, the airborne 4D RNAV system will be discussed. This system has the capability to deliver the aircraft at a metering point or a specific waypoint on a specified flight path, thus helping to maintain the required spacing between the aircraft. This onboard

system must perform the functions of control, guidance and navigation to provide this capability. Navigation determines the best estimate of the reference aircraft states of position and velocity. The guidance uses the navigation data as well as stored information of the reference flight path to generate guidance commands. Control laws are needed to allow the vehicle to respond effectively to guidance commands but are beyond the scope of this discussion since control laws are vehicle dependent. STOL aircraft usually have different control modes dependent upon the method of generating powered lift and degraded flying qualities at the lower speeds. On the other hand navigation and guidance concepts can be derived so that they are applicable to all STOL vehicles in a terminal area environment.

A diagram of the navigation computations is shown in figure 13. The position data as well as body accelerations are transformed to the local coordinate frame where they are filtered in separate X, Y, and Z complementary filters. The sensors used for navigation are the TACAN and scanning beam MLS (MODILS) receivers a body-mounted accelerometer package, the attitude heading reference system, a barometric altimeter and an airspeed sensor. The navigation sub-routines develop estimates of position and velocity with respect to the local coordinate frame which has its origin at the glideslope intercept point. In conjunction with air data, a wind vector is also estimated for use in the guidance computations. In case of

navigation failure, the complementary filters are reconfigured for dead reckoning for a maximum of two minutes using air data and the last wind estimate.

Two navigation aids are needed in the terminal area; one of moderate precision that covers a large area and one of high precision for approach and landing. Such navigation aids are provided at the site of the flight investigations by a TACAN station and the MODILS scanning beam microwave landing system. The MODILS system is an experimental system, a forerunner of future microwave landing systems, which transmits conical azimuth elevation and DME to permit position computation. The inertial data body accelerations are also transformed to the runway reference system for improving the estimate of position and for estimating ground speeds. To achieve a best estimate of aircraft position from the available navigation data it is necessary to combine the data from the various navigation aids using statistical filtering. For the system used in this investigation the navigation data are combined in complementary filters after coordinate transformation. Figure 14 shows the complementary filters for the computation of horizontal position and velocity. It was discovered in flight investigations that a limiter had to be added downstream of the difference computation between raw and filtered navigation data. This prevents filter transients when temporary large navigation errors occur due to frequent brief data dropouts. Additional logic was added to the limiter to vary its magnitude as a function of the noise of the navigation source and to prevent filter lockouts after large errors for a longer time. The filter gains  $\omega_1$ ,  $\omega_2$  and  $\omega_3$  were made functions of the navigation source and distance. The filter gains are low at large distances

from the navigation transmitter to prevent aircraft maneuvers in response to noise. The filter gains are higher close in to the touchdown point where the noise is small and precise control of the aircraft is required.

The system uses discrete electrical signals from the navigation receivers (valids) to indicate reasonable signal strength, or in the case of DME, signal lock. However valids alone do not guarantee good navigation data. For TACAN and VOR stations, there exists a 60 degree cone of confusion, where the azimuth data are erratic. For the MODILS system angle information, there exists a range of proportional signals that is smaller than the signal strength valids would indicate. For these cases the navigation valids are set to be invalid if (1) the aircraft is within the cone of confusion for TACAN, (2) if the MODILS azimuth is outside  $\pm 20^\circ$ , (3) if the MODILS elevation is outside 2 to 15 degrees, or (4) if the MODILS DME is less than 300 meters.

When switching between two navigation aids that give different position information due to bias errors, a position estimation transient cannot be avoided. However, bias errors alone result in small errors of velocity estimates. Therefore, to avoid large velocity estimate transients after navigation aid switching when the position estimate changes rapidly, it was necessary to open the feedback loop called "acceleration bias error compensation" (figure 14) for 15 seconds after switching.

To prevent abrupt dives or climbs of the aircraft when switching vertical navigation sources, some form of signal blending had to be developed. Upon entry into the MODILS signal area, the chosen blending algorithm linearly weights MODILS and altimeter-derived altitudes in such a manner that, after one minute, altimeter altitude is not used at all and MODILS derived altitude is used altogether. Due to the possibility of signal dropouts, this required a somewhat complicated set of logic. A complete description of the navigation system and results of the flight investigation is given in reference 7.

The guidance system used for the approach is based on a flight path stored in the airborne computer which is specified by waypoints (X, Y and Z coordinates) and associated information such as the radius of turn between waypoints and the maximum, minimum, and nominal airspeed between waypoints. A typical approach flight path is shown in figure 15. The dotted lines show a capture flight path which connects the aircraft not yet on the reference flight path to any selected waypoint. The capture flight path is a minimum time flight path which consists of a turn, straight segment, and another turn. A new capture flight path is continuously recomputed including computation of the time of arrival at the final waypoint ( $t_f$ ) until the pilot enters a command to fly on the currently computed path. Slightly before waypoint 10, a predictive bank angle command is given, and just before waypoint 11, a constant vertical acceleration maneuver is performed to acquire the  $5^\circ$  flight-path angle used in this investigation. The short straight-in section (waypoints 12 and 13) is the last segment using the basic

4D guidance laws. The remaining flight path to flare is flown with similar lateral and longitudinal guidance laws except for the system gains, which are high. The gains are relatively low from waypoints 1 to 13 for low control activity and relatively high from waypoint 13 to flare to assure precise path tracking. The guidance is described in reference 8.

The reference flight path and an example of a typical approach carried out during flight investigations are shown in figure 16. The approach was initiated at about 520 meters altitude, and about 280 meters to the right and 30 meters above the reference path. During the turn to final approach, the aircraft remained to the right of the path and then acquired the runway centerline, maintaining that course for the remainder of the approach.

Figure 17 shows the difference between the aircraft position as measured by ground radar and the onboard position estimate as the aircraft passed through a window positioned at a nominal altitude of 30.5 meters on a 5° glideslope. The symbols represent data obtained from flights on two different days. The data show that the aircraft was to the left of the runway centerline and above the glide slope for the majority of the approaches. For these data, the vertical mean error is 2.4 meters above the reference glideslope with a lateral mean error of 1.9 meters to the left of centerline. The  $2\sigma$  errors about the mean are  $\pm 2.6$  meters in altitude and  $\pm 4.2$  meters in the lateral direction.

Guidance errors measured at an altitude of 30.5 meters are presented in figure 18. The reference in this case is the MODILS



5° glideslope as computed by the navigation equations. If the guidance errors were zero, the data points would be clustered on the estimated glideslope centerline which is the origin of the graph. For these data, the vertical mean error is 0.8 meters below the glideslope with a lateral mean error of 0.8 meters to the left of centerline. The  $2\sigma$  vertical and lateral errors about the mean are +2.2 meters and +6.8 meters respectively.

Since no data is available on acceptable approach windows for STOL aircraft, the test flight data were compared with FAA Category II flight director certification criteria for CTOL aircraft to determine whether the navigation system under investigation might be feasible for a flight director landing on a STOL runway in marginal weather. As this program progresses into investigation of flight paths with STOL aircraft, data will be obtained which will assist the FAA in determining acceptable approach window for STOL aircraft. The FAA criteria for CTOL aircraft are included in figure 10. The FAA criteria from AC 120-20 (ref. 11) state for the localizer,

"From an altitude 300 feet above runway elevation on the approach path to the decision altitude (100 feet), the flight director should cause the airplane to track to within +25 microamperes (95-percent probability) of the indicated course. The performance should be free of sustained oscillations."

and for glideslope,

"From 700 feet altitude to the decision altitude (100 feet), the flight director should cause the airplane to track the center of the indicated glideslope to within +75 microamperes or +12 feet, whichever is the larger, without sustained oscillations."

Based on a conventional CTOL runway arrangement, these criteria would translate into allowable deviations of about  $\pm 3.7$  meters (12 feet) vertical and  $\pm 21$  meters (69 feet) laterally for a CTOL aircraft at a longitudinal location defined by the 30.5 meter (100 foot) altitude point on a  $2.7^\circ$  glideslope.

Figure 18 indicates that the two errors measured in the test flights are within those prescribed for CTOL Category II system landing minima (shaded in figure 18). Additional testing is needed to define the performance criteria for STOL aircraft certification for Category II weather minima. This comparison of the test flight data with FAA criteria is not entirely valid, because the landing system, the wind environment, the glideslope, and other parameters were different from those outlined in the FAA advisory circular, AC20-57 (Ref. 12). The advisory circular addresses itself to CTOL jet transports landing while using standard ILS approaches. For simulation it specifies environmental conditions as follows: headwinds up to 25 knots, tailwinds up to 10 knots, crosswinds up to 15 knots, wind shear of 8 knots/30.5 meters from 61 meters to touchdown and moderate turbulence. Nevertheless, the flight data taken at the prevailing wind conditions gave some measure of the system performance.

Figure 19 presents the longitudinal guidance error, the commanded airspeed, the true airspeed, and the ground speed for the approach shown in figure 16. Also shown are the nominal airspeed specified for the reference path (figure 16) and the boundaries of the allowable airspeed commands, designated by the unshaded area, which are based on the aircraft performance capabilities. A com-

parison of the ground speed and true airspeed in figure 19 indicates the strong headwind conditions experienced by the aircraft on the flight path between waypoints 8 and 10. Under such conditions, the aircraft should fly at an airspeed above the nominal to meet the specified arrival time. As shown, the longitudinal error increased linearly and the airspeed command increased above the nominal airspeed for the first 3000 meters of track distance. From waypoints 10 to 11, the longitudinal error decreased linearly at its rate limit, as the aircraft caught up with the target and commanded airspeed approached the nominal. In this approach a longitudinal error of 76 meters, which is equivalent to a 1.3 second time error, remained to be corrected at waypoint 13.

Figure 20 shows a histogram of the time of arrival errors at waypoint 13 for the simulated instrument (hooded) approaches. For these tests, the mean time-of-arrival error is 3.7 seconds late with  $2\sigma$  deviation of  $\pm 3.4$  seconds. The mean time-of-arrival error obtained during these tests may result from the TACAN range error which caused the actual longitudinal distance flown to be longer than the reference path. Additional data are required to establish the system performance for all TACAN errors.

Current manual guidance techniques enable air traffic controllers to deliver CTOL aircraft to the runway within about  $\pm 15$  seconds of the predicted arrival time. This capability corresponds to a single runway acceptance rate of about 40 IFR arrivals per hour using current separation standards. Using the improved capability of the automatic time of arrival guidance system described here it would be possible to increase the runway acceptance rate by about 40 percent (reference 9).

## Summary and Conclusions

The curved approach paths which STOL aircraft will use in the terminal area and the slow speeds at which the aircraft approach place special requirements on the operating systems for the aircraft and on the instrument landing aids which are required on the ground.

The proposed "I" configuration of the Joint Civil/Military Common Use Microwave Landing System will satisfy the navigation requirements for STOL aircraft in the terminal area for the flight paths assumed in this report. While these flight paths appear satisfactory for projected STOL operations, more critical paths (i.e. sharper turns, shorter final straight-in segments, etc.) could place more severe requirements on the MLS.

A 4D RNAV concept consisting of integrated airborne and ground systems will provide precise spacing of arrivals and accurate execution of air traffic controller instructions. It will minimize fuel wasting delays and noise impact and relieve CTOL traffic to a minimum amount of segregated airspace. The system utilizes onboard computer logic to drive the aircraft to a prescribed way-point at an assigned time, and a set of advanced display formats to provide the desired control information to the pilot.

A program of flight investigations of the approach and landing of STOL aircraft using the 4D RNAV system has shown that

1. A capture flight path algorithm is essential for predicting and achieving specified time of arrival at waypoints and at the touchdown threshold.

2. Blended radio/inertial navigation using TACAN and a microwave scanning beam landing guidance system (MODILS) permitted a smooth transition from area navigation (TACAN) to precision terminal navigation (MODILS)
3. Guidance system (flight director) performance measured at an altitude of 30.5 meters was within that prescribed in FAA AC 120-29 for Category II CTOL operations on a standard runway.
4. Dispersion of time-of-arrival errors at a point about two miles from touchdown was  $\pm 3$  seconds ( $2\sigma$ ).

## REFERENCES

1. L. S. Young, Q. M. Hansen, W. E. Rouse and S. S. Osder, "Development of STOLAND, A Versatile Navigation, Guidance and Control System", NASA TMX-62,183, Oct. 1972.
2. Anon. "Evaluation of STOL Microwave Facility Performance Requirements" FAA Standards Development Branch, National Flight Inspection Division, Flight Standards Service, Washington, D. C., January 1972.
3. P. Petersen, R. H. Sawyer, and M. D. McLaughlin, "Integration of STOL Airplanes into the ATC System, "STOL Technology Conference Proceedings", NASA SP-320, pp 291-306, October 1972.
4. S. B. Rossiter, J. Mauer, and P. J. O'Brien, "ATC Concepts for V/STOL Vehicles Parts 1 and 2, "FAA Report No. FAA-RD-73-47, April 1973.
5. H. Erzberger and T. Pecsvaradi "4D Guidance of STOL Aircraft in the Terminal Area," STOL Technology Conference Proceedings. NASA SP-32-, pp 307-332, October 1972.
6. Leonard Tobias and Heinz Erzberger, "Simulation of 4D RNAV in the Terminal Area," Proceedings of 1974 IEEE Systems, Man and Cybernetics Conference, October 1974, Dallas, Texas.
7. Frank Neuman and David N. Warner, Jr., "A STOL Terminal Area Navigation System," NASA TMX-62-348, May 1974.
8. D. W. Smith, F. Neuman, D. M. Watson and G. H. Hardy, "A Flight Investigation of a Terminal Area Navigation and Guidance Concept for STOL Aircraft, NASA TMX-62375, July 1974.
9. Anon. Report of Department of Transportation Air Traffic Control Advisory Committee, Department of Transportation, Washington, D. C., December 1969.
10. RTCA SC117 Committee Report, "A New Guidance System for Approach and Landing, December 18, 1970.
11. FAA Advisory Circular AC 120-20 Criteria for Approval of Category II Landing Weather Minima.
12. FAA Advisory Circular AC 20-57 Automatic Landing Systems.

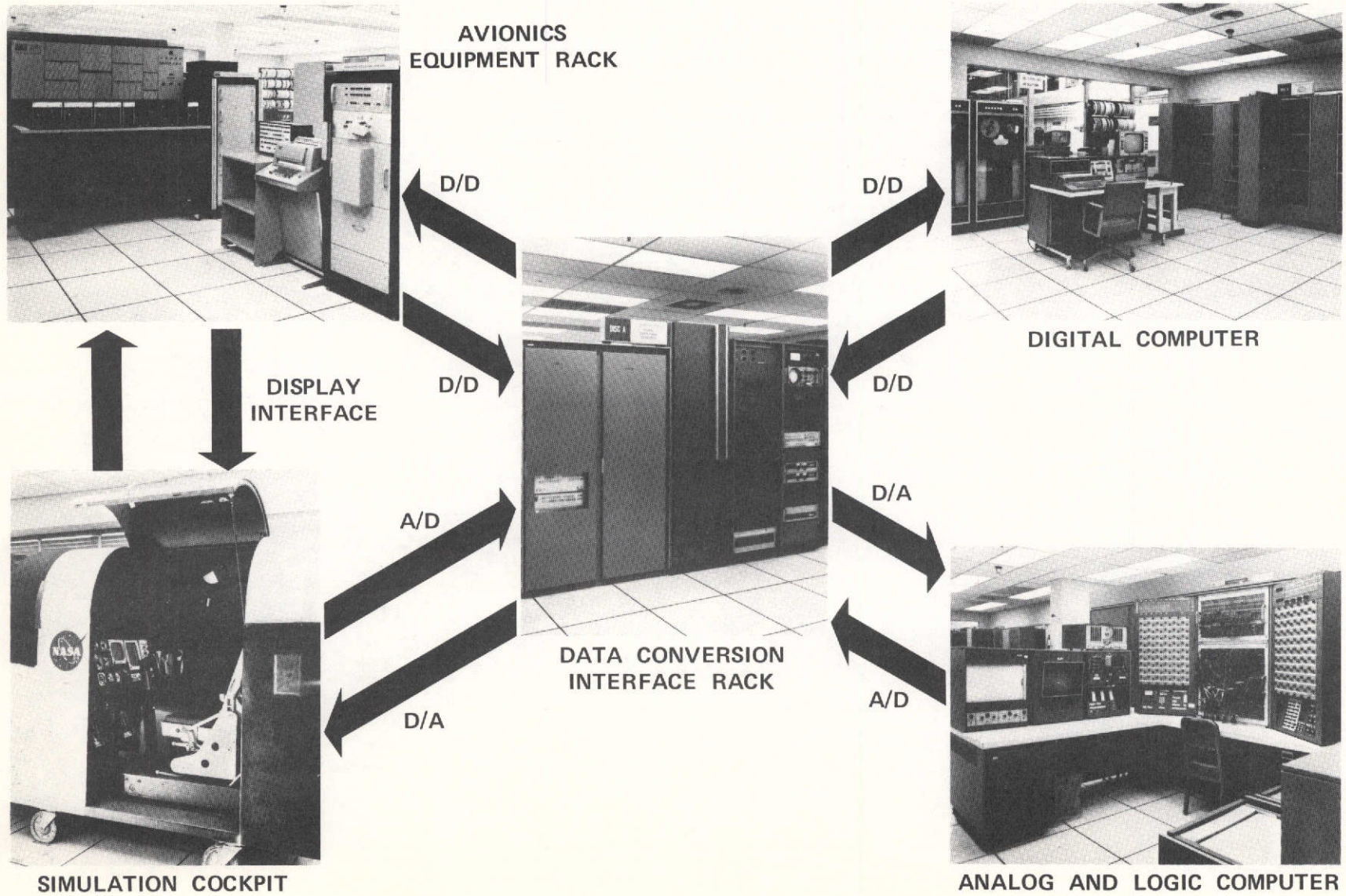

Figure 1.— Simulation facility.

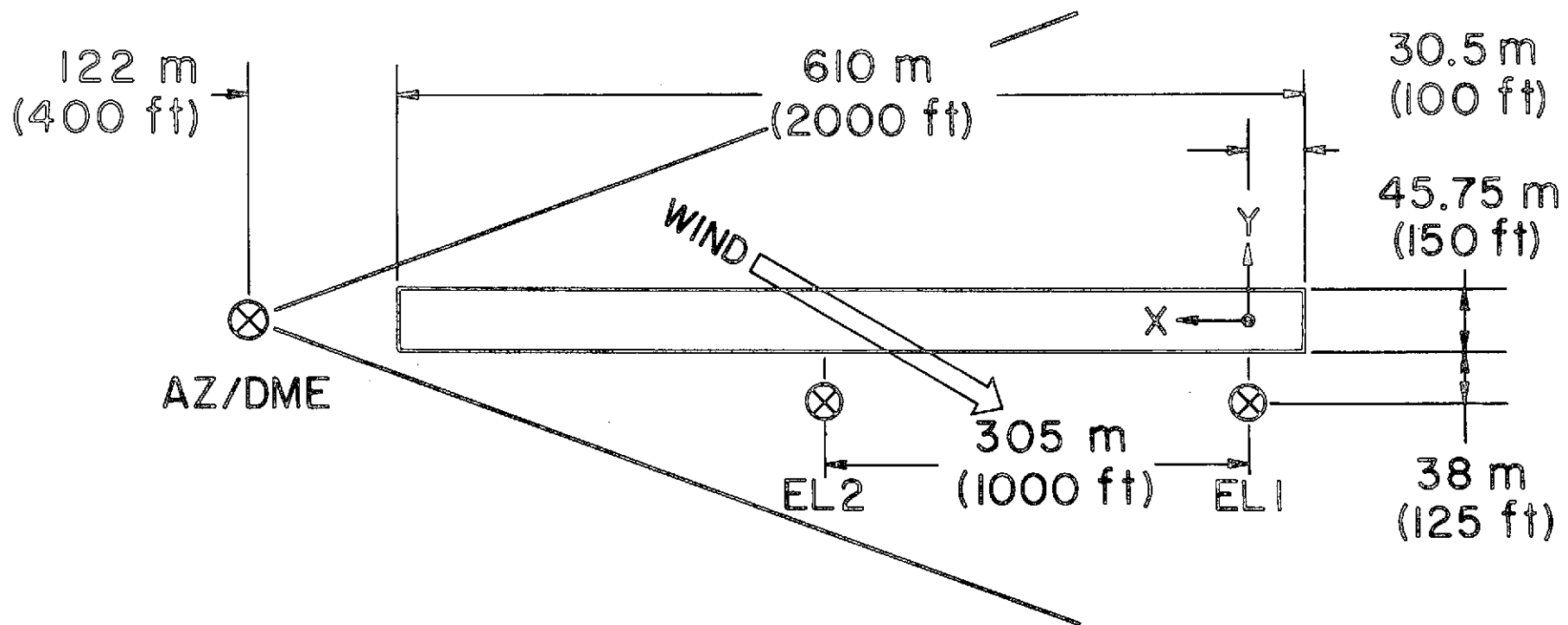

Figure 2.— Stolport geometry.



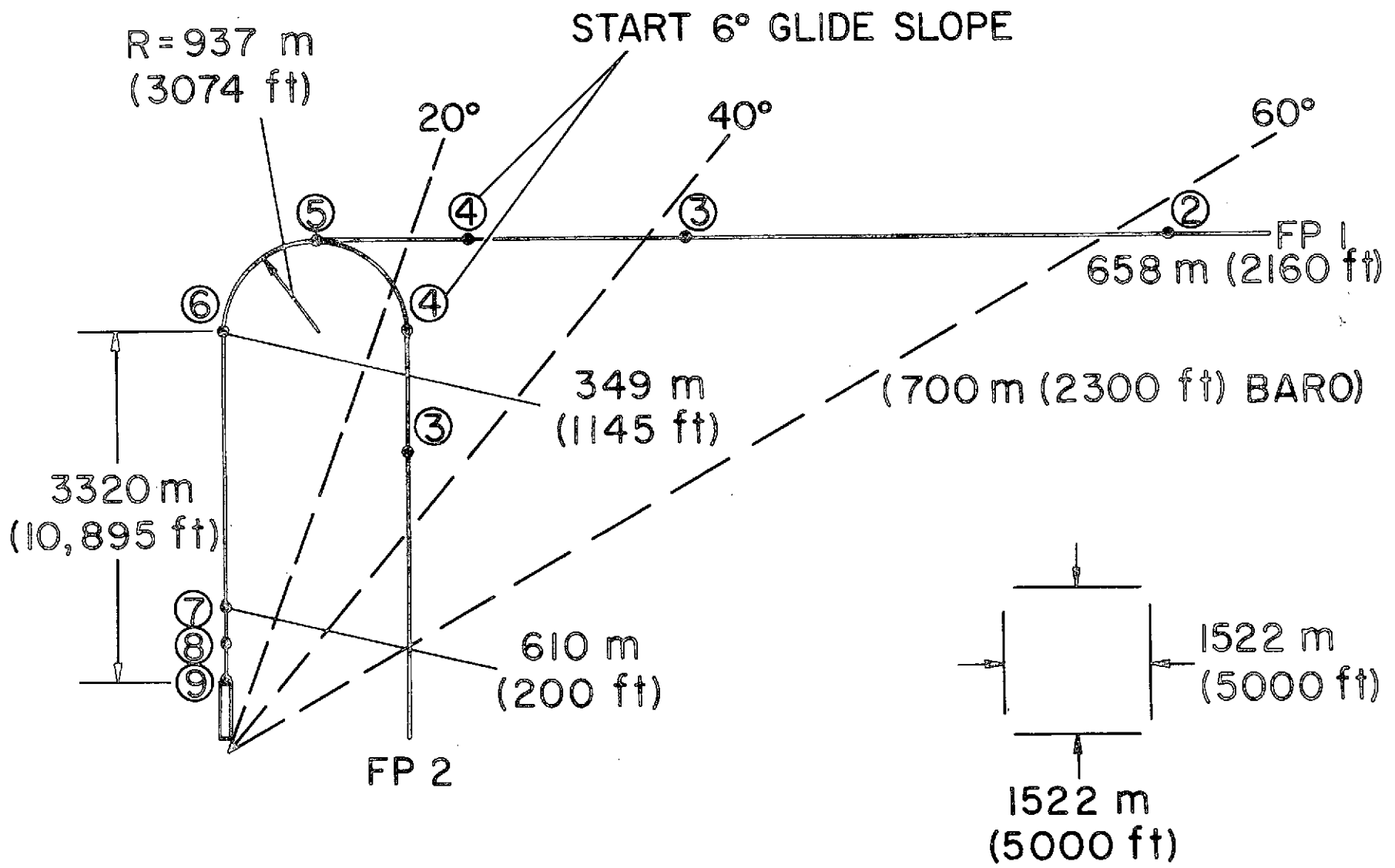

Figure 3.— Flight paths.

A. FAA AUTO LANDING SYSTEM ADVISORY CIRCULAR 20-57A FOR CAT II CTOL

- $2\sigma$  LONGITUDINAL TOUCHDOWN DISPERSION = < 457 m TOTAL (1500 ft)  
(NEED NOT BE SYMMETRICAL).
- $2\sigma$  LATERAL TOUCHDOWN DISPERSION = <  $\pm 8.2\text{m}$  (27 ft) ABOUT R/W CENTERLINE.

ATTEMPTING TO SCALE THESE FIGURES TO A STOLPORT GIVES:

- $2\sigma$  LONGITUDINAL STOL TOUCHDOWN DISPERSION = < 214 m TOTAL (700 ft)
- $2\sigma$  LATERAL STOL TOUCHDOWN DISPERSION = <  $\pm 7.3\text{ m}$  OF CENTERLINE (24 ft)

B. FAA CRITERIA FOR APPROVAL OF CAT II LANDING WEATHER MINIMA  
ADVISORY CIRCULAR AC 120-20 FOR ILS/CTOL 30.5 m DECISION HEIGHT  
(100 ft)  
WINDOW.

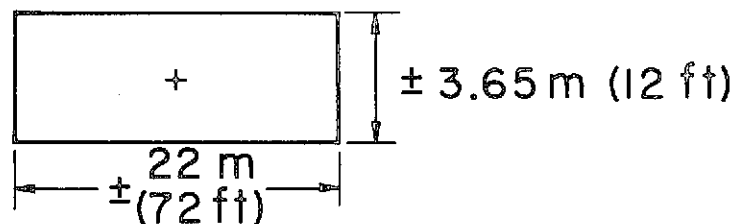

THE VALUES GIVEN FOR THIS WINDOW ARE INTERPRETED TO MEAN THAT THE AIRCRAFT SHOULD BE WITHIN THE SPECIFIED LIMITS FOR AT LEAST 95% OF THE APPROACHES ATTEMPTED. WITH THE ASSUMPTION OF A GAUSSIAN DISTRIBUTION, THE RESULTING VERTICAL AND HORIZONTAL  $2\sigma$  ERRORS BECOME  $\pm 3.65\text{ m}$  (12 ft) AND 22 m (72 ft) RESPECTIVELY.

Figure 4.- Criteria.

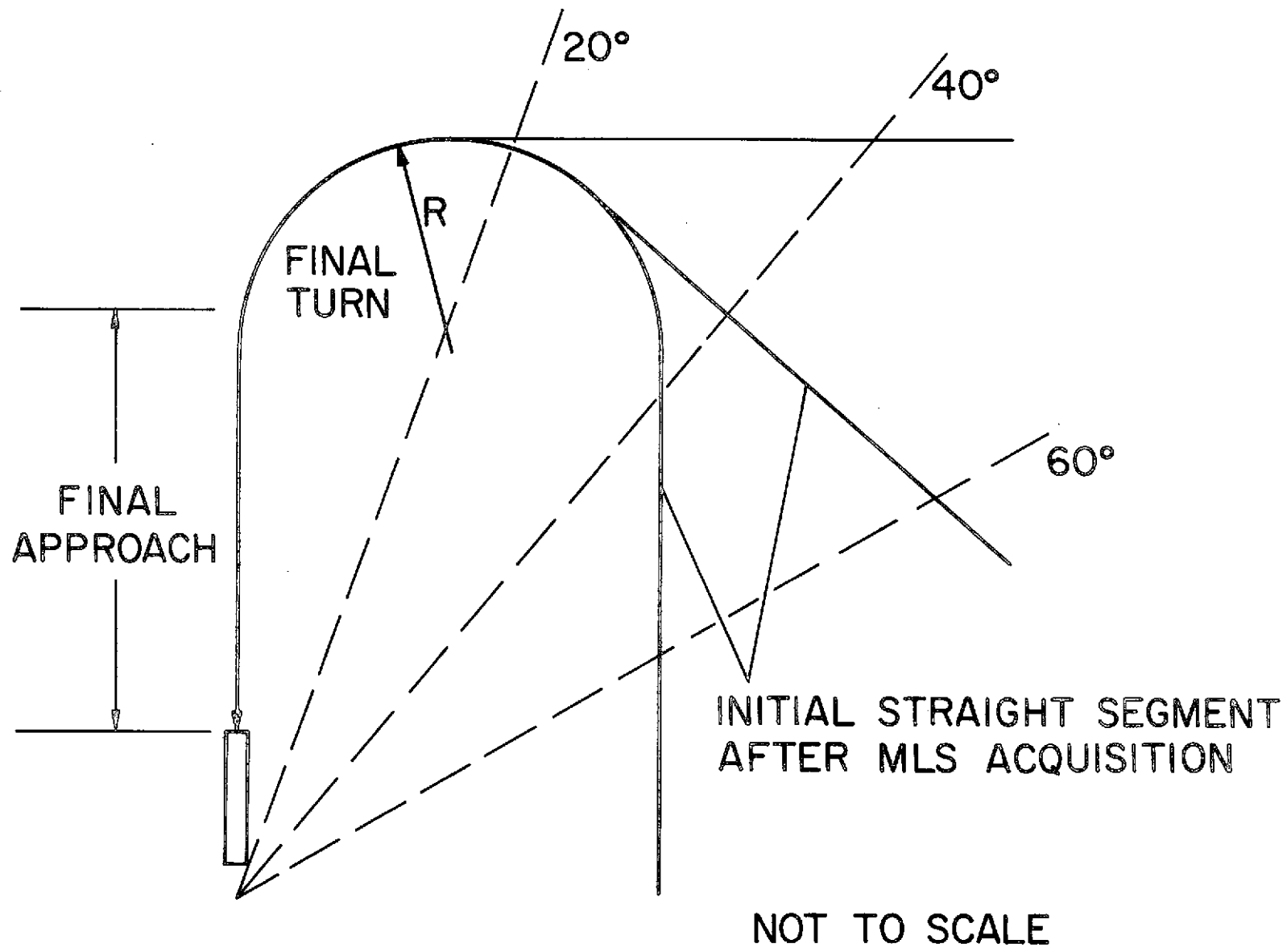

Figure 5.— Azimuth coverage elements.

MLS FUNCTION		MLS SPECIFICATIONS FOR STOL OPERATIONS		RTCA SC-117 SPECIFICATIONS	
		CAT III WITH COMPLEMENTARY FILTERING (HORIZ. & VERT.)	CAT II WITHOUT COMPLEMENTARY FILTERING	CAT I D	CAT III I
<b>ACCURACY (<math>1\sigma</math>)</b>					
AZIMUTH	BIAS	0.15°	0.15°	0.14° (0.37°)	0.02° (0.12°)
	NOISE	0.15°	0.1°	0.07° (0.18°)	0.02° (0.11°)
ELEVATION NO. 1	BIAS	0.1°	0.1°	0.04° (0.12°)	0.04° (0.04°)
	NOISE	0.1°	0.04°	0.05° (0.13°)	0.05° (0.03°)
ELEVATION NO. 2	BIAS	0.07°	—	—	0.02° (0.03°)
	NOISE	0.08°	—	—	0.02° (0.03°)
DME	BIAS	30.5 m	30.5 m	91.5 m	6.1 m
	NOISE	30.5 m	12.2 m		
<b>COVERAGE</b>					
HORIZONTAL		±45°	±45°	±20°	±40°
MAXIMUM VERTICAL		20°	20°	20° EL <sub>1</sub>	20°
RANGE		10 nm	10 nm	8° Az and DME 20 nm	20 nm
<b>DATA RATE</b>		5 HZ ALL BUT EL <sub>2</sub> @ 10 Hz	5 Hz	5 Hz	5 Hz ALL BUT EL <sub>2</sub> @ 10 Hz

Figure 6.— Comparison of STOL aircraft MLS requirements to RTCA SC-117 specifications.

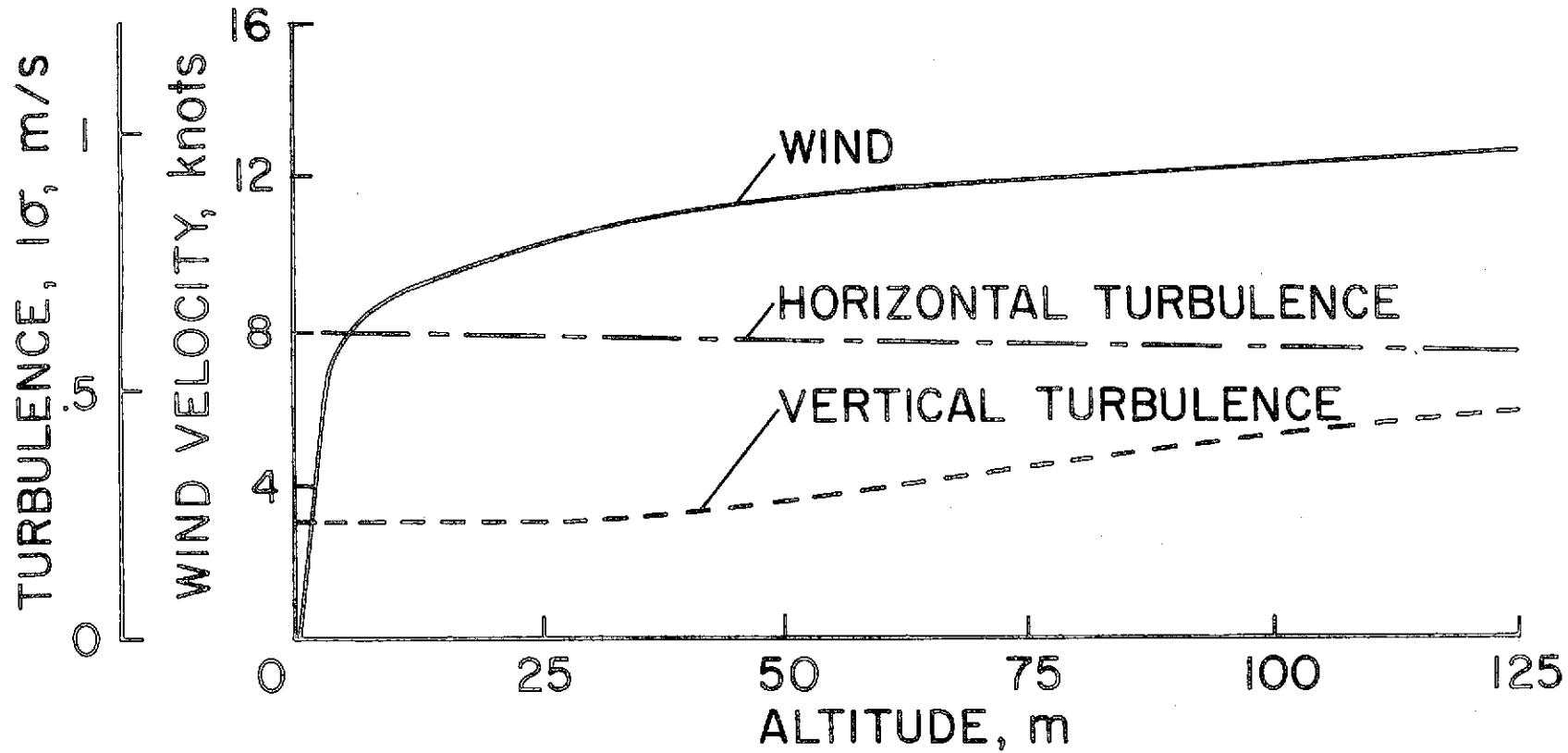
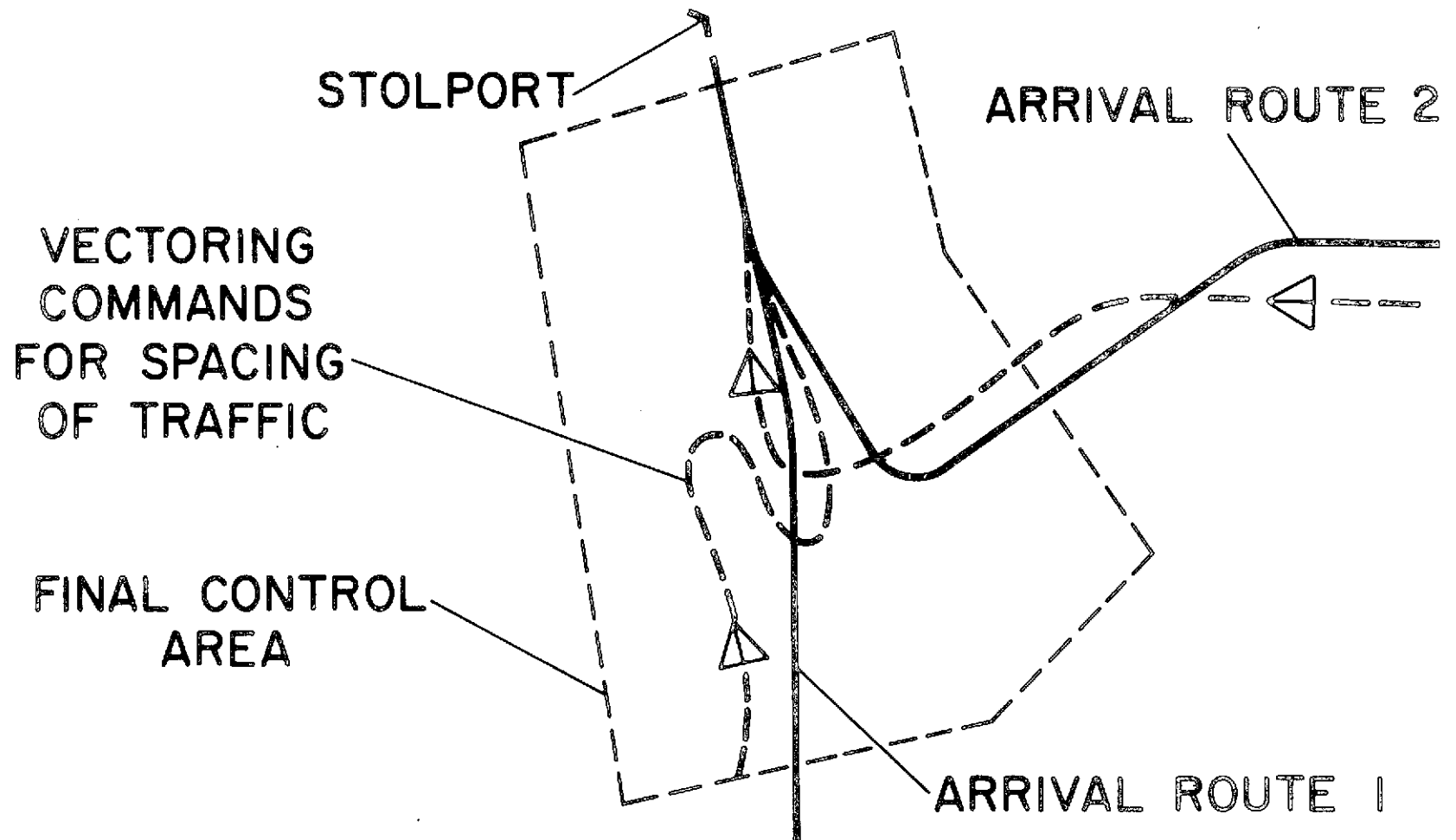

Figure 7.— Atmospheric disturbance model.



- HIGH PILOT AND CONTROLLER WORKLOAD
- LARGE TRACK ERRORS
- DELAYS

Figure 8.— STOL routes in high density terminal areas.

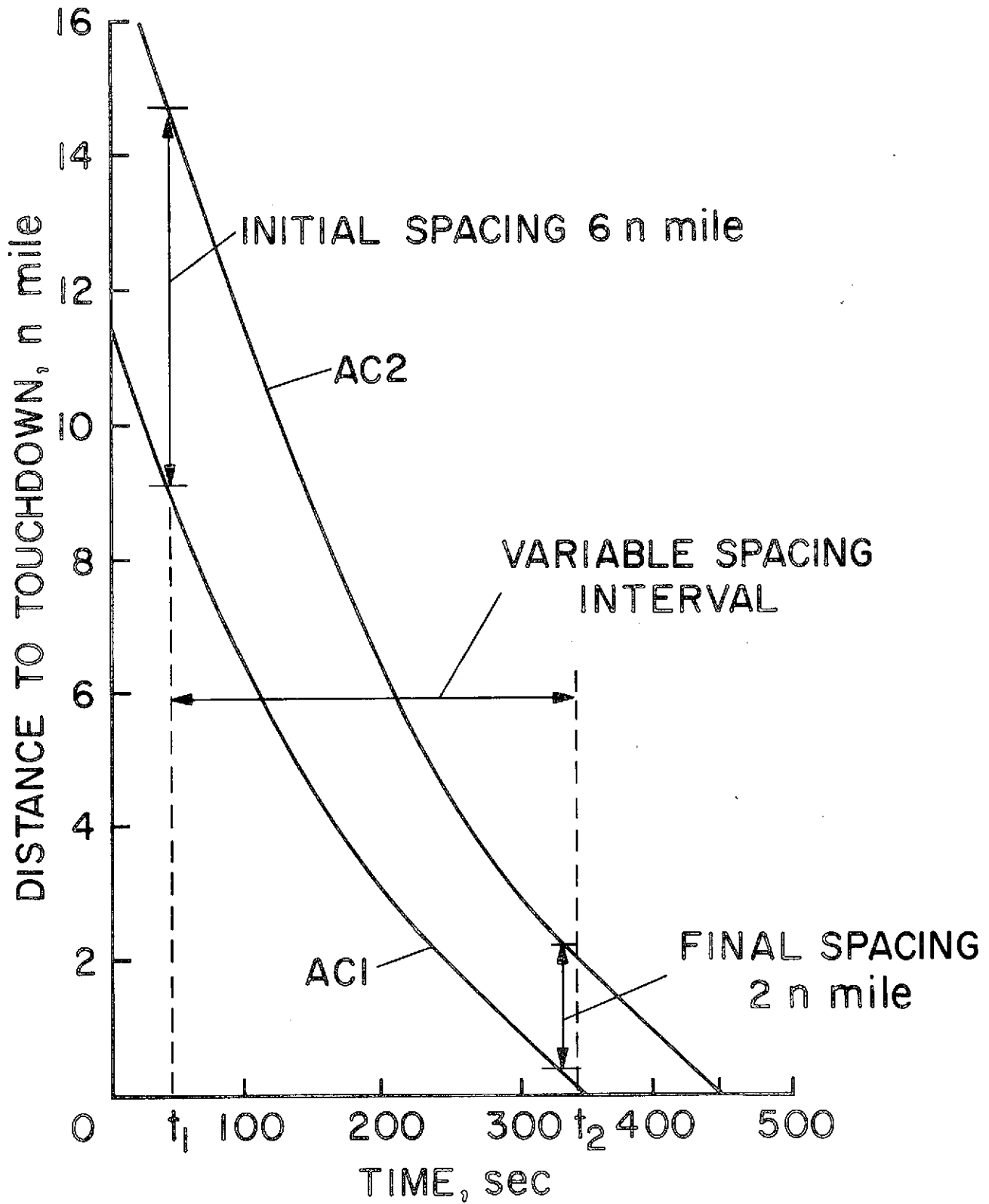

Figure 9.— Trajectories of STOL aircraft flying a common approach.

SYSTEM	TIME/PLACE	DIRECTION OF INFORMATION FLOW	FUNCTION
A/C	AS EARLY AS POSSIBLE; NOT LATER THAN 4-5 MIN PRIOR TO ARRIVAL AT FEEDER FIX	A/C TO GND	<ul style="list-style-type: none"> <li>● IDENTIFY TYPE EQUIPMENT ON BOARD;</li> <li>● PREFERRED ROUTE;</li> <li>● RANGE OF POSSIBLE LANDING TIMES;</li> <li>● ESTIMATED TIME AT FF</li> </ul>
GND	PRIOR TO A/C ARRIVAL AT FEEDER FIX	GND TO A/C	<ul style="list-style-type: none"> <li>● ASSIGN 3D ROUTE</li> <li>● ASSIGN EARLIEST FEASIBLE LANDING TIME (METERING AND SEQUENCING)</li> <li>● PROVIDE EST. WIND PROFILE</li> </ul>
A/C	PRIOR TO A/C ARRIVAL AT FEEDER FIX	A/C TO GND	<ul style="list-style-type: none"> <li>● COMPUTE 4D FLIGHT PATH</li> <li>● CONFIRM FEASIBILITY OF ASSIGNED LANDING TIME</li> </ul>
	DURING FLIGHT BETWEEN FEEDER FIX AND TOUCH DOWN	NONE	<ul style="list-style-type: none"> <li>● PERFORM 4D RNAV</li> </ul>
		A/C TO GND	<ul style="list-style-type: none"> <li>● REPORT PREDICTED ERRORS IN ASSIGNED LANDING TIME</li> </ul>
GND		GND TO A/C	<ul style="list-style-type: none"> <li>● MONITOR TRAFFIC AND RESOLVE POTENTIAL CONFLICTS</li> <li>● ASSIGN REVISED LANDING TIMES, IF NECESSARY</li> </ul>

Figure 10.— Air-ground interactions in the 4D RNAV environment.



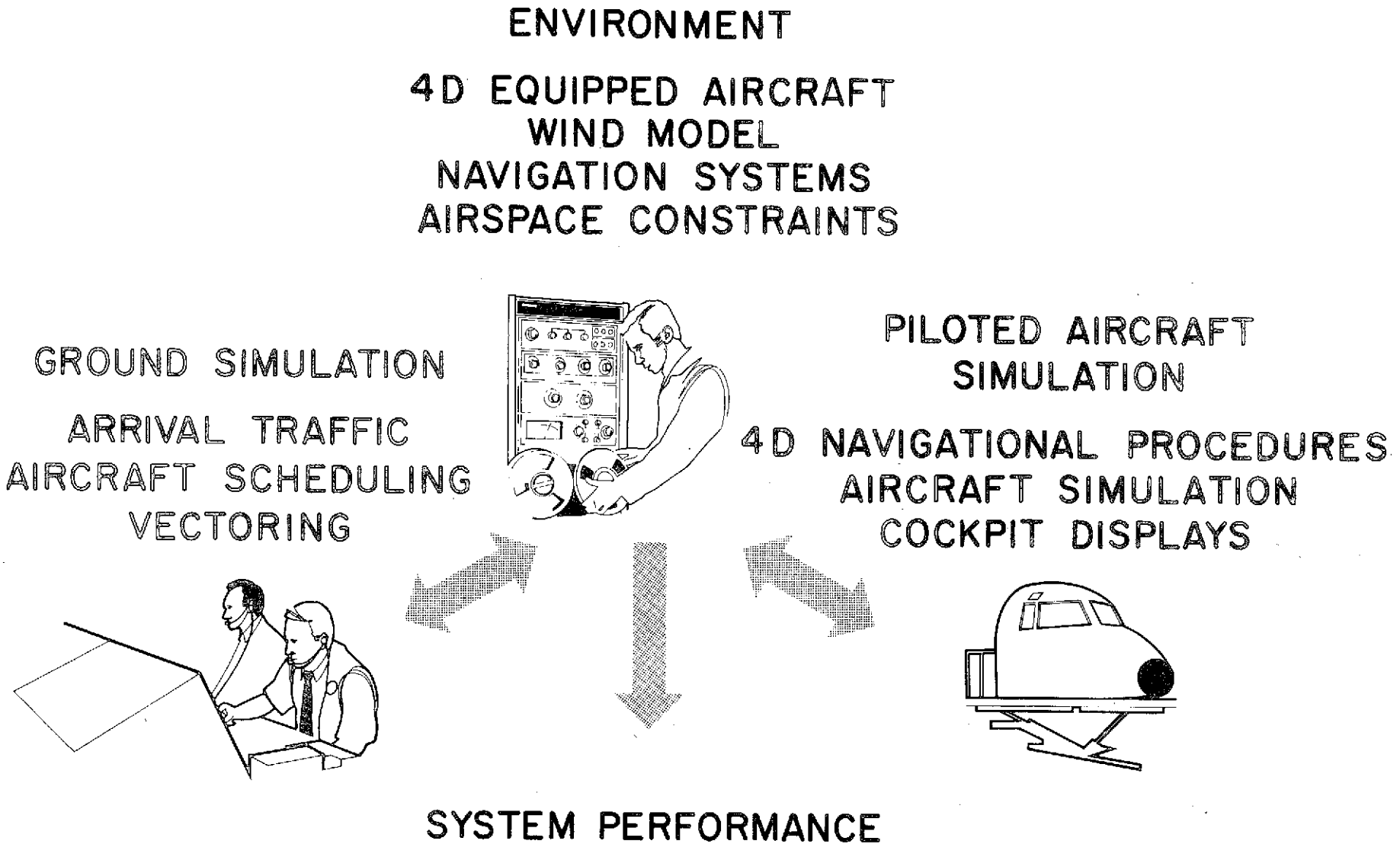
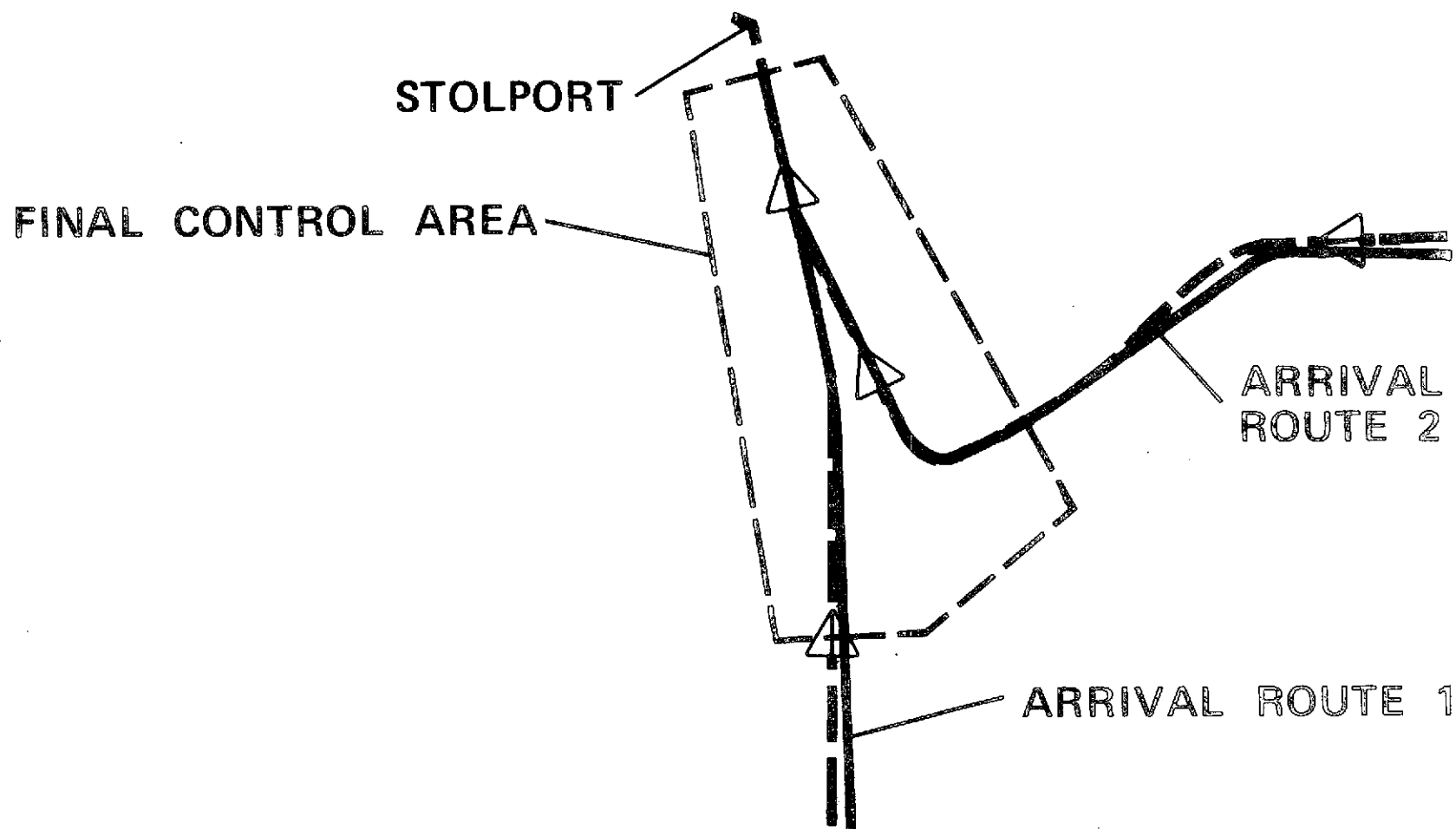

Figure 11.— Interactive terminal area simulation.



- REDUCED COMMUNICATIONS WORKLOAD
- INCREASED CAPACITY
- REDUCED DELAY AND FUEL CONSUMPTION

Figure 12.— Preliminary simulation results (on-board 4D navigation with computer-assisted sequencing).

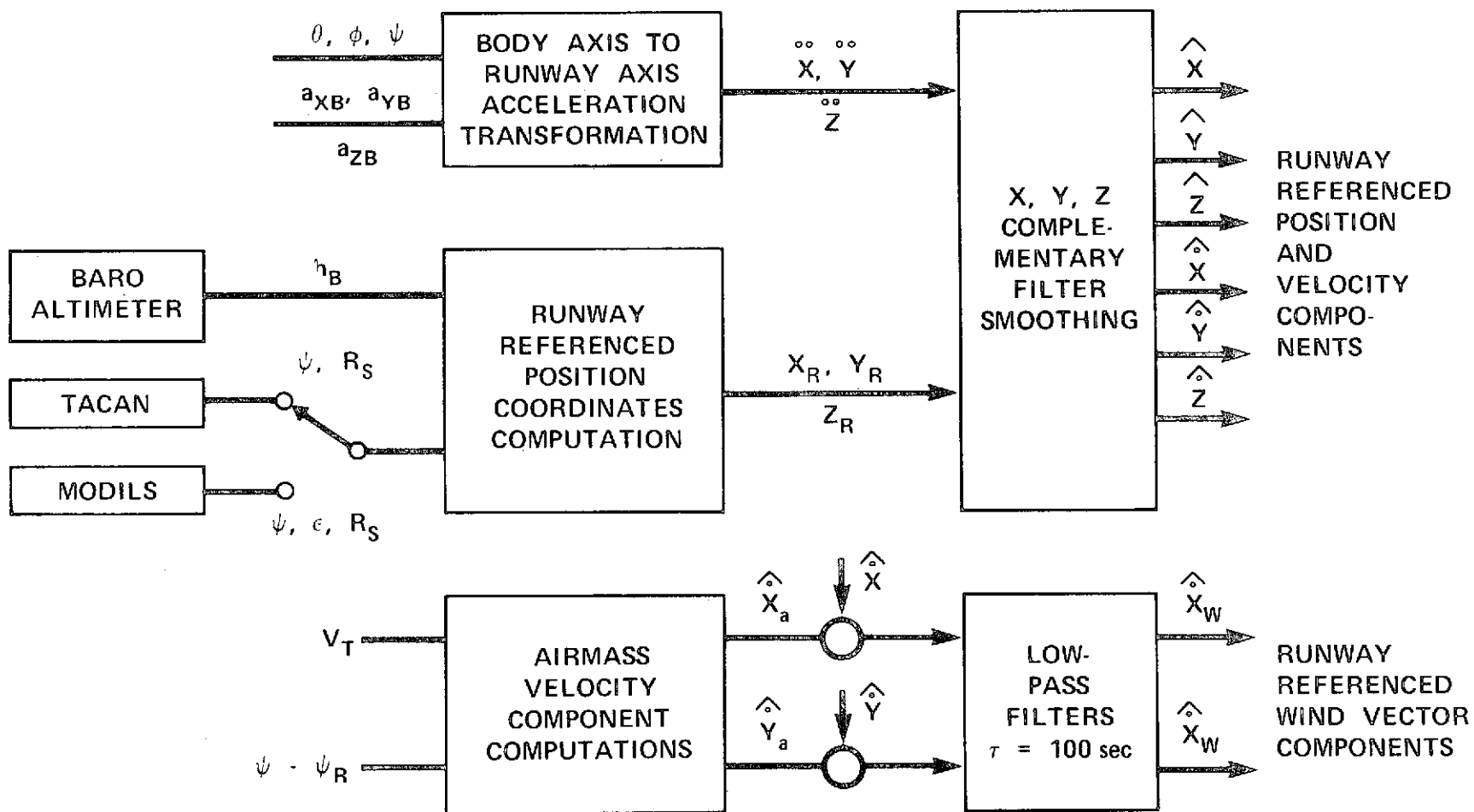

Figure 13.— Block diagram of navigation computations.

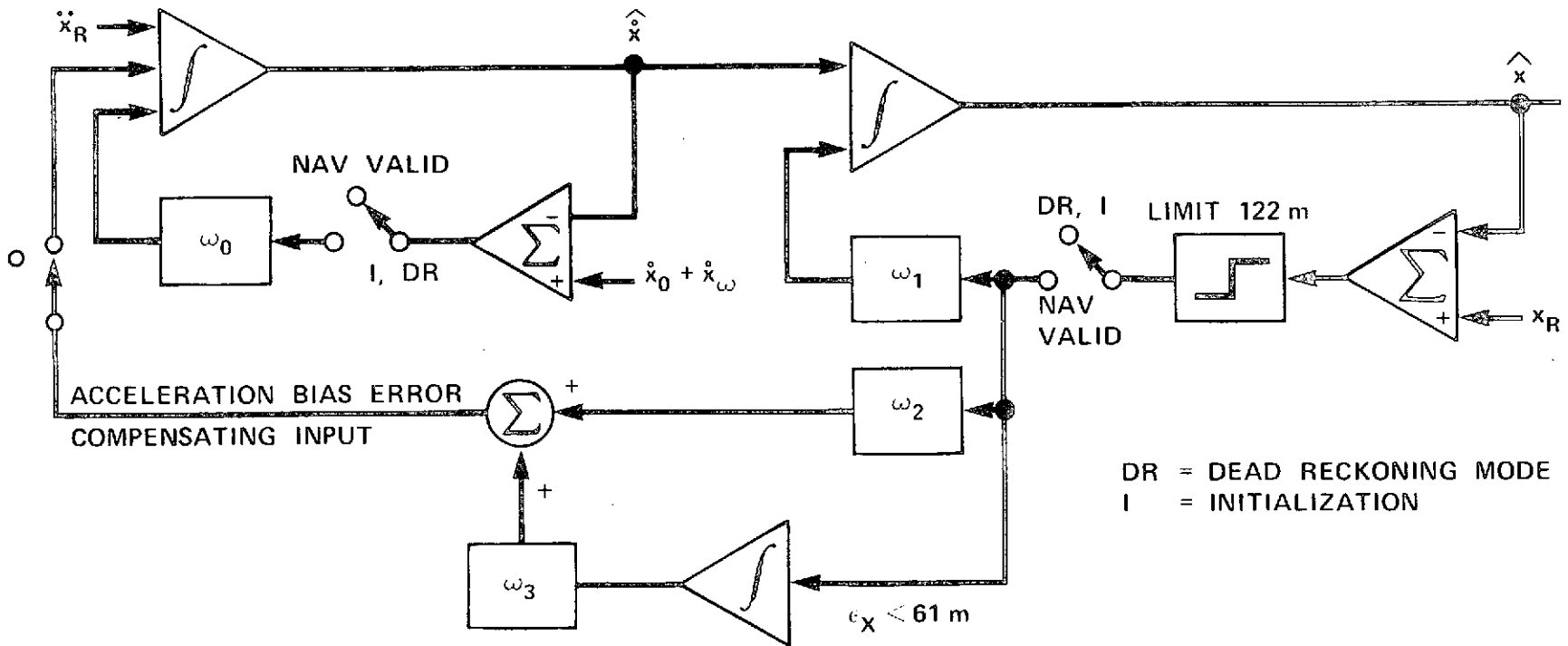

Figure 14.— Third-order filter for  $\hat{X}$  and  $\hat{Y}$ ,  $\hat{\dot{X}}$ ,  $\hat{\dot{Y}}$  estimates.

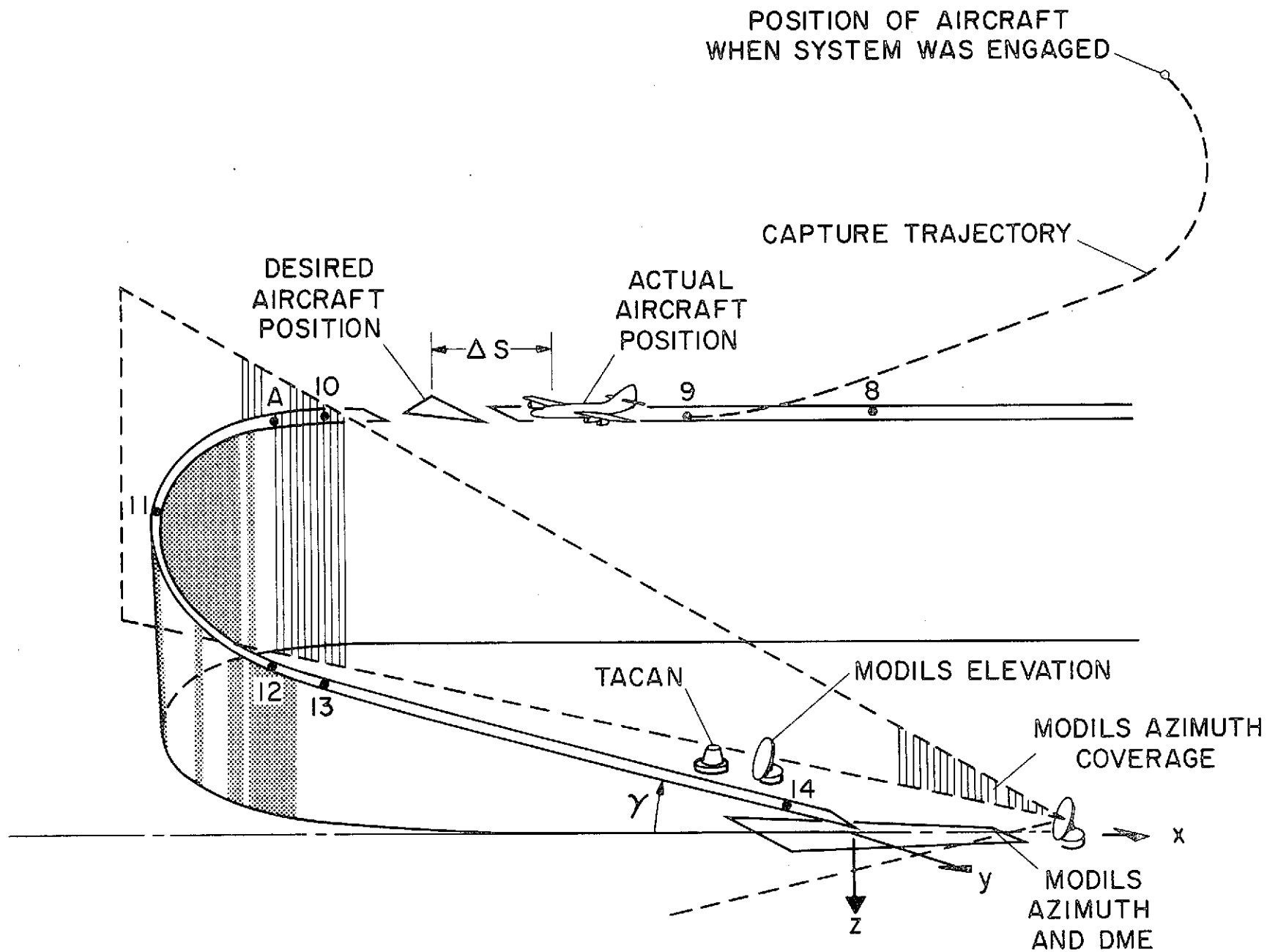

Figure 15.— Reference approach flight path.

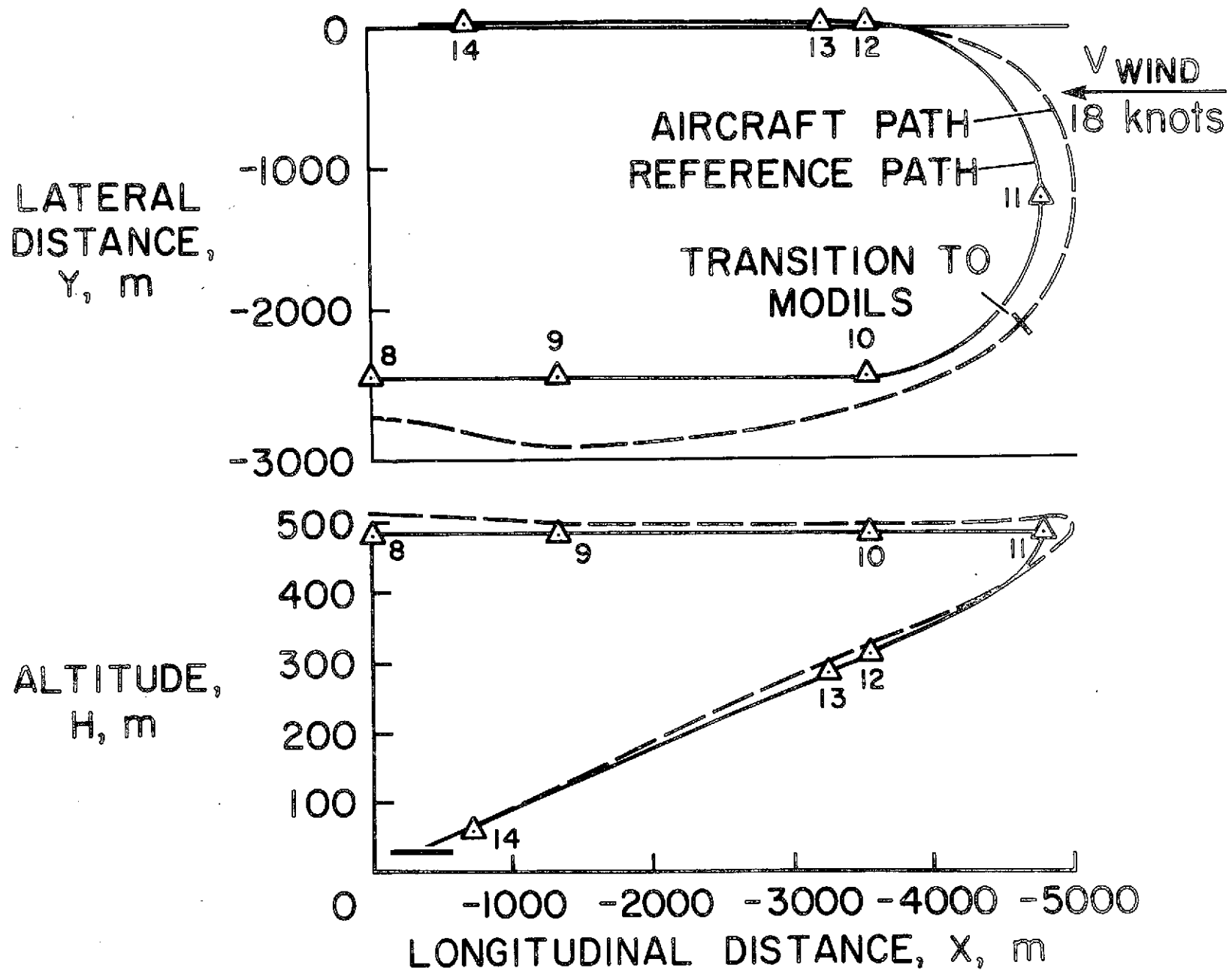

Figure 16.— Typical flight path.

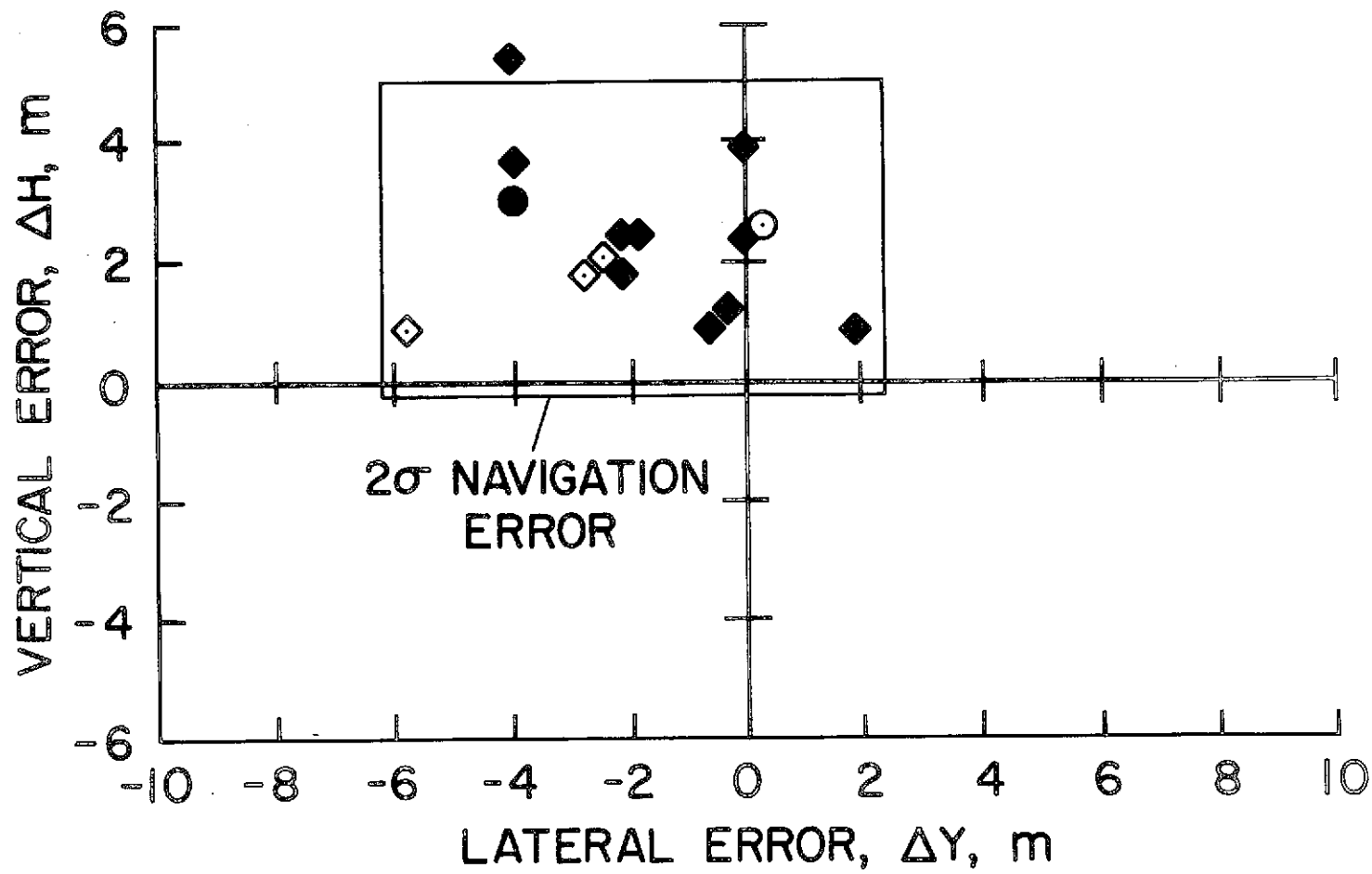

Figure 17.— Navigation errors at 30.5 m.

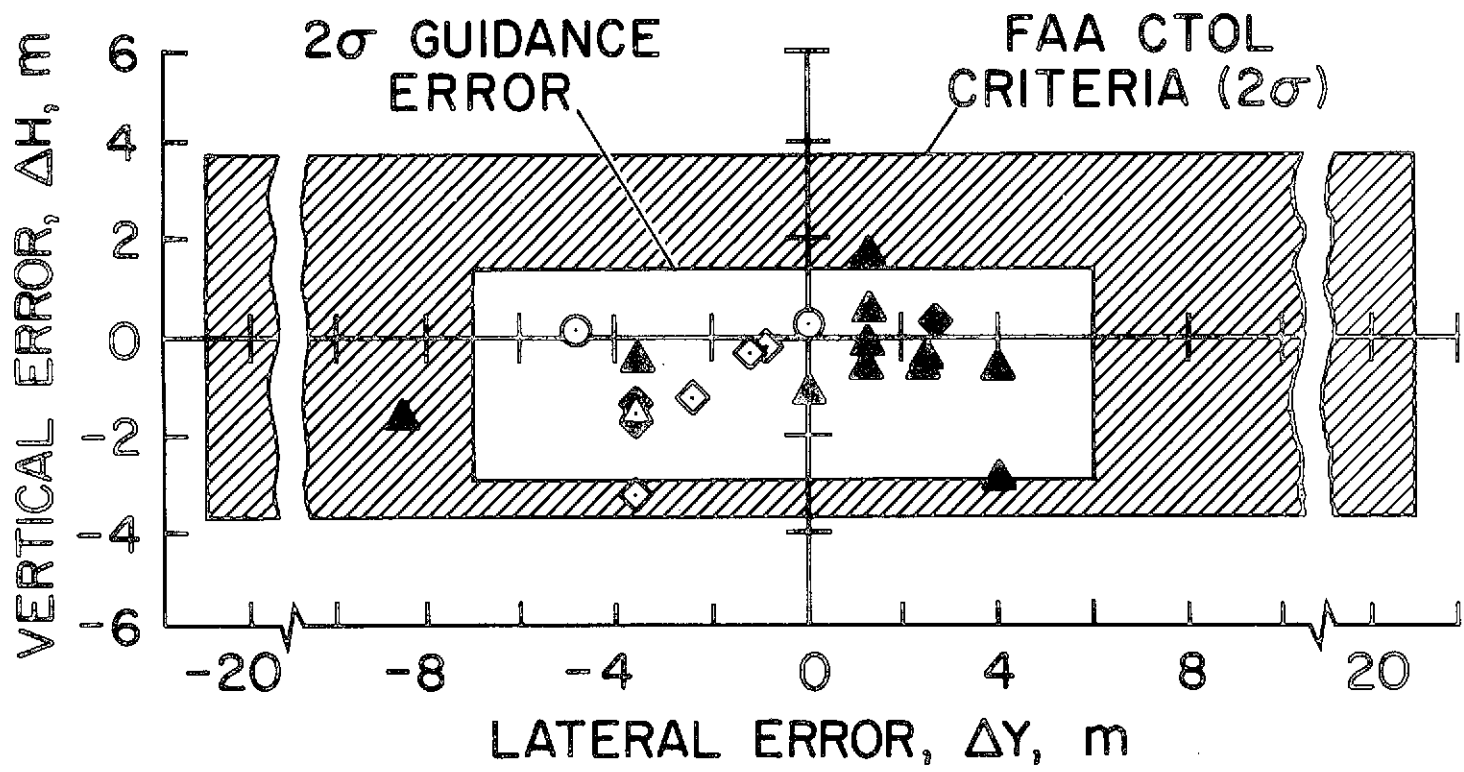

Figure 18.-- Guidance errors at 30.5 m.



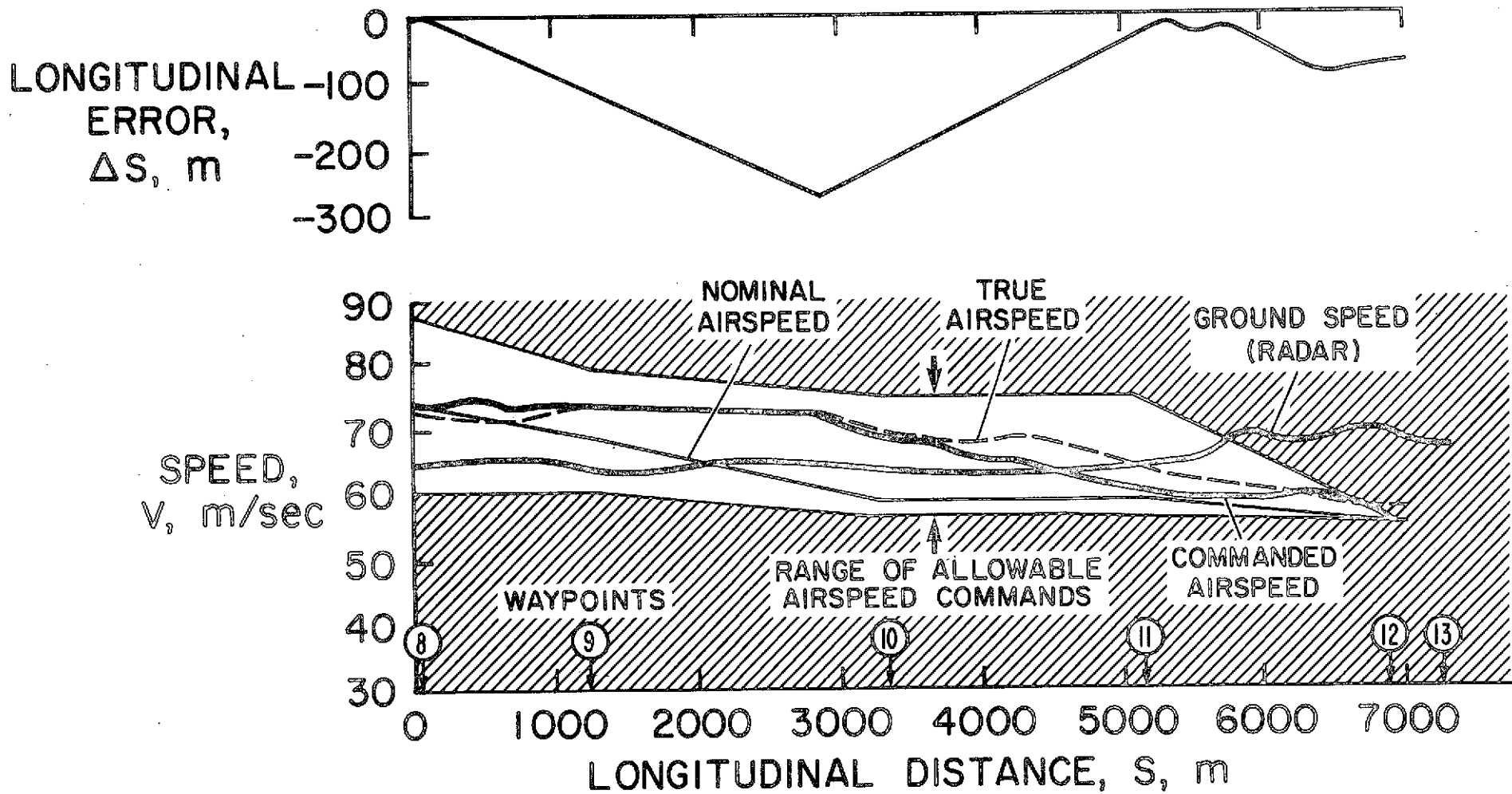

Figure 19.— Longitudinal guidance.

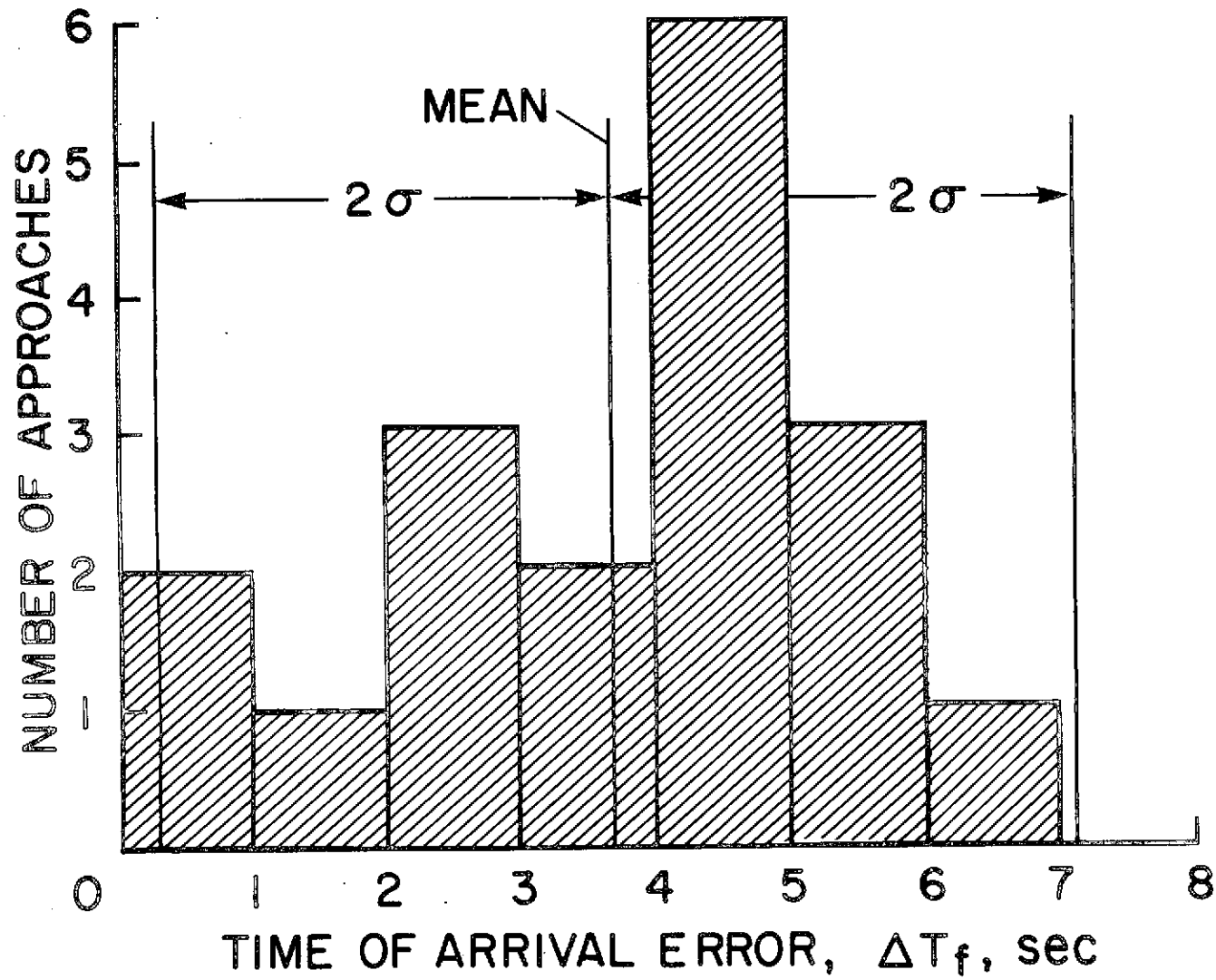

Figure 20.— Time-of-arrival error at waypoint 13.