

NASA CR-

141755

PARAMETRIC TEST OF A Zr(IV) OXIDE-POLYACRYLIC ACID DUAL LAYER  
HYPERFILTRATION MEMBRANE WITH SPACECRAFT WASHWATER

(NASA-CR-141755) PARAMETRIC TEST OF A  
ZIRCONIUM (4) OXIDE-POLYACRYLIC ACID DUAL  
LAYER HYPERFILTRATION MEMBRANE WITH  
SPACECRAFT WASHWATER Final Report, Aug.  
1973 - Aug. 1974 (Clemson Univ.) 62 p HC

N75-21636

Unclas  
19426

G3/37

C. A. Brandon, J. L. Gaddis, and Ali M. El-Nashar  
Department of Mechanical Engineering  
Clemson University  
Clemson, South Carolina 29631



NAS 9 - 13669  
T - 932 - 5 - 1  
January 1975  
Final Report

Prepared for:  
Johnson Space Center  
Houston, Texas 77058

## ACKNOWLEDGEMENT

The authors wish to acknowledge with thanks the contributions made to the research program described in this report. Mr. Dick Cianciotto and Mr. Alan Mills played key roles in carrying out preliminary membrane formation tests and in layout of this high pressure research facility. Mr. Don Todd played a key role in conducting the parametric performance tests and in evaluating the data. Especially, the authors wish to thank Mr. O.K. Houck and Mr. Bill Reveley, NASA technical monitors for continuous guidance and encouragement to maintain proper direction and schedule.

## ABSTRACT

Performance data consisting of solute rejections and product flux have been measured, as dependent on the operation parameters. These parameters and ranges were pressure ( $5 \times 10^6 \text{N/M}^2$  (750 psi) to  $7 \times 10^6 \text{N/M}^2$  (1040 psi)), temperature  $347^\circ\text{K}$  ( $165^\circ\text{F}$ ) to  $368^\circ\text{K}$  ( $200^\circ\text{F}$ ), velocity (1.6 M/sec to 10 M/sec), and concentration (up to 14x). Tests were carried out on analog washwater. Data taken include rejections of organic materials (TOC), ammonia, urea, and an assortment of ions. The membrane used was a dual layer, polyacrylic acid over zirconium oxide, deposited in situ on a porcelain ceramic substrate.

## TABLE OF CONTENTS

	PAGE
1.0 SUMMARY . . . . .	1
2.0 INTRODUCTION . . . . .	3
3.0 CONCLUSIONS . . . . .	4
4.0 RECOMMENDATIONS . . . . .	5
5.0 TEST DESIGN AND CONDUCT . . . . .	6
5.1 Description of Objectives . . . . .	6
5.2 Prospectus . . . . .	6
5.3 Test Apparatus Design . . . . .	8
5.3.1 Design Considerations . . . . .	8
5.3.2 Detailed Design and Materials . . . . .	9
5.3.3 Instrumentation . . . . .	12
5.4 Membrane Formation . . . . .	14
5.4.1 System Wash . . . . .	14
5.4.2 Formation . . . . .	14
5.4.3 Regeneration . . . . .	14
5.4.4 Re-use of Substrate Tubing . . . . .	14
5.5 Summary of Operations . . . . .	15
6.0 DISCUSSION OF RESULTS . . . . .	15
6.1 Data Analysis Procedures . . . . .	15
6.2 Results . . . . .	33
6.2.1 Pressure . . . . .	33
6.2.2 Velocity . . . . .	35
6.2.3 Temperature . . . . .	35
6.2.4 Concentration . . . . .	39
6.3 Conclusions with Respect to End Item Design . . . . .	39
6.4 Experience with Washwater Preparation . . . . .	42
6.5 Experience with Mechanical Design . . . . .	46
7.0 PRETREATED URINE TEST RESULTS . . . . .	47
8.0 REFERENCES . . . . .	49
APPENDIX A - Derivation of Mass Balance Relations . . . . .	50
APPENDIX B - Test Log Summary . . . . .	54
APPENDIX C - NASA Analytical Methods . . . . .	57

## 1.0 SUMMARY

A membrane technology using zirconium oxide followed by polyacrylic acid layers has been developed by the Oak Ridge National Laboratory. In 1972 engineering personnel at Clemson University applied this technology on a feasibility test basis to the reclamation of potable water from washwater for NASA. The present contract extends the earlier work to determine the effects of basic operating parameters on the performance of the membrane.

A test rig was designed and constructed which would be capable of operation in the intended range. Basically a unit with 70 atmospheres pressurization at 80 liters per minute of near-boiling-temperature water was provided. The minimum operating volume was just under 10 liters and the maximum volume about 200 liters. Washwater was generated and stored in accordance with an established procedure which uses shower water and clothes wash from test subjects supplemented by the addition of deficient chemicals.

The test was executed in two portions. In the first portion the effects of pressure, temperature, and velocity were separately determined. The flow arrangement was configured to permit a small portion of raw feed to mix with recycle concentrate to form the fluid exposed to the membrane. Standard conditions of pressure =  $6.8 \times 10^6 \text{ N/M}^2$  (950 psi), temperature = 348 K (75C), and velocity = 7.7 M/sec were selected. While maintaining other parameters constant with loop concentration approximately 2.4 times feed concentration, each operating parameter was varied from its standard value. Pressures from  $5.27 \times 10^6 \text{ N/M}^2$  to  $7.24 \times 10^6 \text{ N/M}^2$  (750 to 1040 psi), temperatures from 348K to 366K (75C to 94C), and velocities from 1.5 to 7.7 M/sec were observed.

The second test portion comprised the concentration variation. The flow arrangement was configured to route all recycle concentrate to mix with the feed reservoir. Simple mass balance theory shows this configuration to be equivalent in operation to a long once-through membrane. A batch representing ten men-showers was processed 93 percent to completion while operating at the standard test conditions. Further processing was limited by the minimum operating volume to insure full flow to the pump suction.

Conductivity and product flow rate data were taken regularly and pH measured infrequently. Small samples (about 100 ml) were sent to a local contractor for C.O.D. analysis. Large samples (about 1 liter) were shipped to NASA Houston for analysis. The primary items of importance were initially considered to be organic carbon materials, ammonia, and urea. Results of the testing showed the feed ammonia content to be larger than anticipated so that ammonia is clearly the most difficult solute to reduce to acceptable levels. A single filtration recovering 93 percent of the feed resulted in an averaged product ammonia content of 6.5 mg/l from feed levels of 24 mg/l. Based on this observation a product-recycling system would reduce the ammonia content to below 1 mg/l in less than three passes. The product thus produced would contain very small quantities of organics and acceptable amounts of urea in addition to traces of other solutes.

The results generally were near those previously experienced during the feasibility demonstration in 1972. However the urea rejection was found to be substantial (about 60 percent) rather than the low (about 10 percent) level heretofore determined. No explanation for this is advanced. However the urea molecule is anticipated to be excluded on the basis of its molecular weight rather than by ion exclusion. Comparison with other non-ionized molecules having molecular weights of the order of 100 indicate that a 60 percent rejection is not unreasonable.

One important test point at the lower velocity extreme was marred by the conjunction of two phenomena. At the time when the low velocity points were being run, a second feed batch was introduced which had markedly different pH. A decline in performance was registered and it is not possible to conclusively separate the effect of new feed and low velocity. However it is deemed most probable that the low velocity was not responsible for the performance decline. Further testing is recommended to permit proper evaluation.

## 2.0 INTRODUCTION

Beginning in 1965 researchers at the Oak Ridge National Laboratory (ORNL) began to evaluate the solute separation potential of hydrous metal oxide semi-permeable membranes. In 1969 it was determined that a dual layer membrane formed of zirconium oxide and polyacrylic acid had improved lifetime and solute separation potential. During the following period ORNL explored the application to seawater, brackish water, and to various waste streams. In 1972 Clemson University applied the membrane to spacecraft wash-water under contract to NASA-Langley. This application was considered promising due to the properties of the membrane which allow high temperature operation ( $347^{\circ}\text{K}$  and above) and good performance for relatively low concentration solutions. The product water from a batch of processed shower water met the accepted standards for potable water. Based on this favorable result NASA has elected to evaluate the effect of various operational parameters on the flux and rejection properties of the dual layer ZrO-PAA membrane.

### 3.0 CONCLUSIONS

The membrane evaluation was executed according to plan with the following essential results achieved. The rejections of various solutes are not strongly variable with pressure, temperature, velocity, or concentration in the range tested. Temperature above 358°K resulted in slight declines in rejection, while velocity below 3 M/sec apparently resulted in a larger performance decline. The velocity variation is important to the designer to enable rational decisions on pump requirements and system configurations, but the long term effects associated with low velocity (not studied herein) are probably more important in this respect. The velocity effect was masked by conjunction with a change in pH so that no strong conclusions can be made.

Rejections of important solutes were determined to be

Total Organic Carbon	96%
Ammonia (NH <sub>3</sub> )	80 to 90%
Urea	60%

Other solute rejection and feed concentrations are such that product water concentrations are well within potability limits. The ammonia rejection appears to be determined to a relatively large uncertainty though all procedures indicate higher accuracy should have been attained.

A batch of washwater was processed 93 percent toward completion to determine the effect of concentration. The laboratory system minimum volume prohibited further processing. The calculated value of mixed product concentration compared to feed in ppm is as follows.

	<u>Feed</u>	<u>Mixed Product</u>	<u>Allowed Maximum Level</u>
TOC	180	37	100
Urea	64	50	50
NH <sub>3</sub>	24	6.5	1

From this it is apparent that NH<sub>3</sub> is the critical solute, and consequently that a multistage system is likely to be required.



#### 4.0 RECOMMENDATIONS

The primary results obtained herein should be utilized in a design optimization of a hyperfiltration system. The design effort should be flexible enough to accommodate a range of tube sizes. The effect of not yet determined, long-term results of low velocity exposure should be treated in an appropriate manner. This study will result in an ideal goal system which assures minimum total weight penalty - valid for any of several tube sizes.

The long-term effects on performance should be studied experimentally. A life test should be conducted during which the effects of velocity at relatively high concentration may be documented. Also the effect of fresh feed additions on membrane performance, particularly flux, may be documented.

Consideration should be devoted to the problem of the substrate mechanical support. The use of the desirable inside pressurization will require a different tube than that used in the present program. Tubes employed in this program, pressurized on the outside, may prove acceptable in performance and are expected to be adequately strong. Fabrication of elementary support arrangements should be carried out to allow laboratory evaluation of basic performance.

It is suggested that the effect of feed pH on rejection of solutes, particularly  $\text{NH}_3$  and urea, be determined. A re-examination of low velocity conditions at perhaps even higher concentration should also be conducted.

## 5.0 TEST DESIGN AND CONDUCT

### 5.1 Description of Objectives

The object of the work reported herein was to determine the effect of certain operating parameters on the performance of the hyperfiltration membrane under consideration when operating on washwater. The parameters are pressure, temperature, velocity, and concentration. It is normally conceded that the pressure will be of the order of 60 atmospheres, as generally higher quality product water is achieved at higher pressure. The temperature of the stored shower water was anticipated to be 347°K for sterilization, and the range of the test data was anticipated to cover the range from 347°K to near boiling. Velocity was expected to be important over both short and long time scales. The short term effect is due to concentration polarization, which describes the rise in concentration level at the membrane over that of the mainstream flow. The concentration polarization is velocity dependent because the level of concentration near the membrane is inversely proportional to the rate of diffusion from membrane to free stream which is in turn nearly proportional to velocity. Concentration polarization was expected to become noticeable at 2 M/sec and to be severe at 0.3 M/sec.

The long term effect of velocity is not clearly understood, but generally is referred to as fouling or scaling. First, in the supersaturated solution, the increased concentration at the membrane caused by a reduction in velocity produces faster deposition of solute. This type of fouling, which includes that type called scaling, may occur. Second, there may be materials in suspension which, at low velocity, may be deposited on or attracted to the surface of the membrane. Any such materials would tend to remain on the membrane by virtue of the flux being withdrawn and by the pressure of the water passing through it. Particularly the immiscible liquids are considered candidates for such action in that they could spread enormously under the influence of pressure and shear after initially contacting the membrane. Third, there could be erosion or modification of the membrane material itself. This effect would possibly be reduced at lower velocities.

In addition to pressure, temperature, and velocity effects, it was anticipated that solute concentration may affect membrane performance. The rejection of ion-exclusion membranes is highly dependent on concentration whereas for ultrafiltration membranes rejection is less dependent on concentration, for solutes in ionic bonded forms. Experience with washwater gained in earlier testing indicates that organic substances (measured by TOC or COD) are rejected almost equally or perhaps even increasingly with concentration. The rejections of  $\text{NH}_3$  and urea, other important substances, are also not strongly affected by concentration.

### 5.2 Prospectus

Hyperfiltration membranes can be utilized in any of the basic single stage schemes shown in Figure 1. In the first feedwater is fed at a constant rate into a module configured to allow the recovered product and residual concentrate to exit. This "once through" arrangement is different from the second scheme shown (Figure 1b) which recirculates most of the loop fluid while withdrawing a

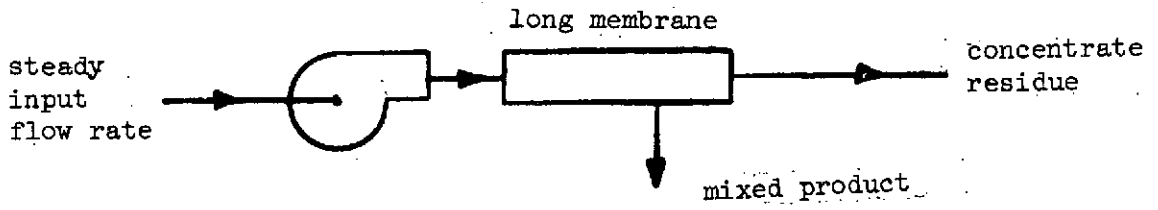

1a. Once-through Arrangement

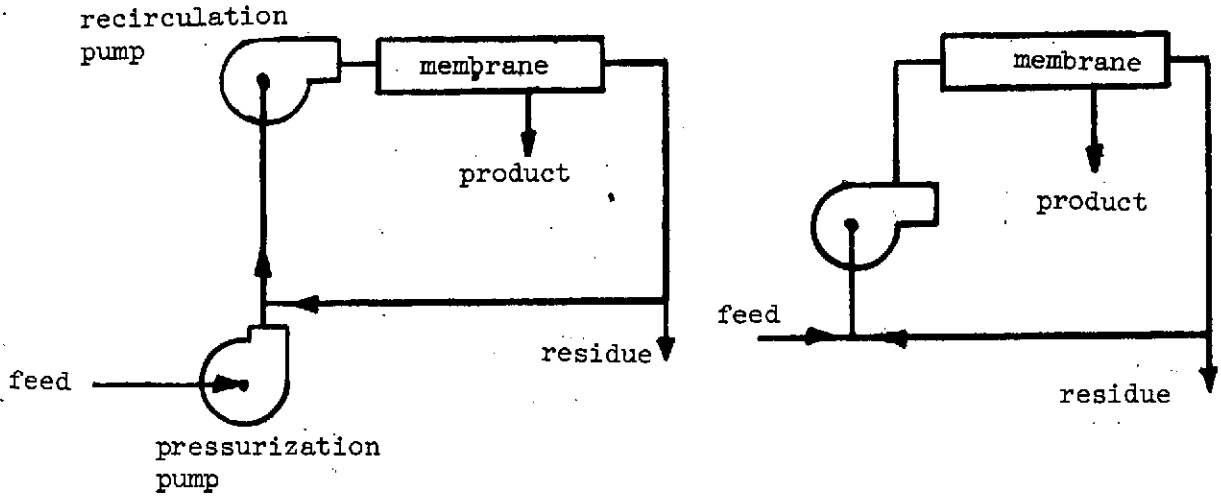

1b. Recirculating Arrangements

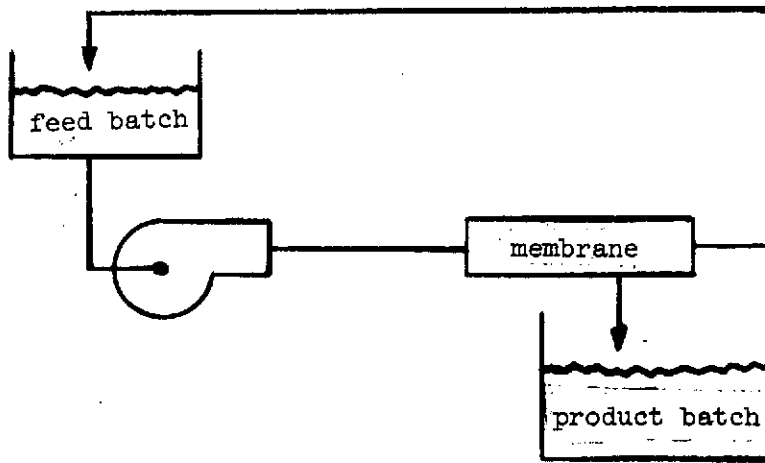

1c. Batch Processing Arrangement

Figure 1. Typical Single Stage Arrangements

desired ratio of loop flow to the product flow. The third scheme is a batch process in which the loop fluid includes the feed reservoir. The process continues until the desired recovery fraction of the original fluid has been processed as product water.

Appendix A presents a simple analysis of these various flow arrangements using a hyperfilter. The analysis presented there shows that the batch process and the once-through arrangement are equivalent and are favored over a recirculating type system.

Based on the feed analysis of Reference 1 it is deemed feasible that a single stage system could suffice. However, based on results shown herein, the feed is more contaminated with  $\text{NH}_3$  than anticipated so that multistage filtration is required. The requirement of multistage filtration leads to greater energy consumption and possibly some increase in complexity and weight. The conclusion of above that the once-through or batch process is superior to recirculation carries over to the multistage concepts.

While the use of a recirculating system is not anticipated for a flight article, such a system is useful in the laboratory. For, when operated at proportionate concentration, it may be maintained to within a close tolerance over an extended time. Thus one may effectively insure constant concentration while varying temperature, and other parameters. In addition any suspected performance variation may be examined by restoration of conditions to determine the occurrence of irreversible changes. Because of these advantages a recirculating system was used to determine the effects of pressure, temperature, and velocity. Then a batch of shower water was processed in escalating concentration simulating the individual points of a once-through filtration arrangement.

While the use of the steady-state recirculation arrangement allows the loop concentration to remain essentially unchanged during other parametric variations there is a slight skewing of the relative concentration of the various solutes since rejection on each is different. For example, suppose solutes 1 and 2 are rejected with different efficiencies, and then compare a once-through arrangement and a steady-state arrangement. At the position in the once-through arrangement where the concentration of solute 1 is identical with that of solute 1, in the steady-state arrangement, the concentrations of solute 2 are not identical in the two arrangements. By use of concentration analysis, presented in Appendix A, one may determine that relative abundance is effectively independent of flow arrangement in the concentration range associated with the parametric tests.

### 5.3 Test Apparatus Design

#### 5.3.1 Design Considerations

Test hardware design was largely determined by the choice of the membrane support tube. The Selas single-hole tube or seven-hole tube having  $0.27\mu$  pore size was selected. Use of this support precluded the use of filter aid or other composite form of support. Also, the benefit of inside-out product flow

direction allowed the flow regime which is the most easily understood, that of tube flow. Having chosen the support (dictating flow area) and selected 7 M/sec to be a required velocity, a pump flow rate of 8 l/min at high pressure (60 atmos) was estimated. All pump makers surveyed indicated that their 8 l/min unit was the same hardware as a larger unit, typically 150 to 400 l/min. An approximately 80 l/min pump was purchased, the selection based on other considerations. To fully utilize this flow rate it was determined that the use of a membrane formed of multiple tubes in parallel would lead to faster data production. However, we were not successful in operating a multiple tube arrangement and the test was performed on a single seven-hole tube ceramic support.

### 5.3.2 Detailed Design and Materials

Experiments were conducted utilizing a single pump pressurization-circulation system shown schematically in Figure 2. Feed is taken from an elevated tank which maintains the net positive suction head required by the pump. Pressurized feed flows either through the module, a pressure reduction valve and flow indicator, or through a pressure reduction valve in the by-pass line. By-passed feed and concentrate re-join and the stream is directed either to the suction of the pump or to the feed tank by a 3-way valve. Heat generated by the pump is removed by a concentric tube heat exchanger using tap water coolant in the annulus.

Resistance to corrosive attack of chemicals used in cleaning of the system, formation of the membrane and by the feed itself is required when selecting wetting materials (see page 14 for wash and formation technique). Though the system must withstand the feed and wash solutions with a minimum of structural attack, prevention of contamination of solutions used in membrane formation is critical to good membrane quality and largely determines the materials selected.

Relying on previous experiences at Clemson University and ORNL, the basic metal chosen was series 300 stainless steel. The locations and types of materials used throughout the wetted portion of the system are given in Table I.

The pump chosen was a Sunflo single stage, high speed centrifugal, model P2CHB manufactured by Sunstrand Fluid Handling, Denver, Colorado. The pump is constructed of type 316 stainless steel with a tungsten carbide and carbon rotary seal. Stationary seals of teflon were used throughout.

One and one-half inch diameter 316 stainless steel pipe with a flex joint of natural rubber was used between the elevated feed tank and the suction of the pump. Stainless steel tubing with Swagelok fittings and valves was used throughout the rest of the system. Tygon tubing is used to return product to the feed tank and for other temporary transportation of fluids from or to storage. The three 55-gallon feed and storage tanks are constructed of type 304 stainless steel.

Pump protection was furnished by switches which deactivated the system when feed tank level dropped below a certain level, or when pump discharge manifold temperature exceeded a set level (normally 90°C). Successful membrane formation was accomplished utilizing the single 7-hole tube module shown in Figure 3. This module was used for all tests. The individual channel diameters are 2 mm,

ORIGINAL PAGE IS  
OF POOR QUALITY

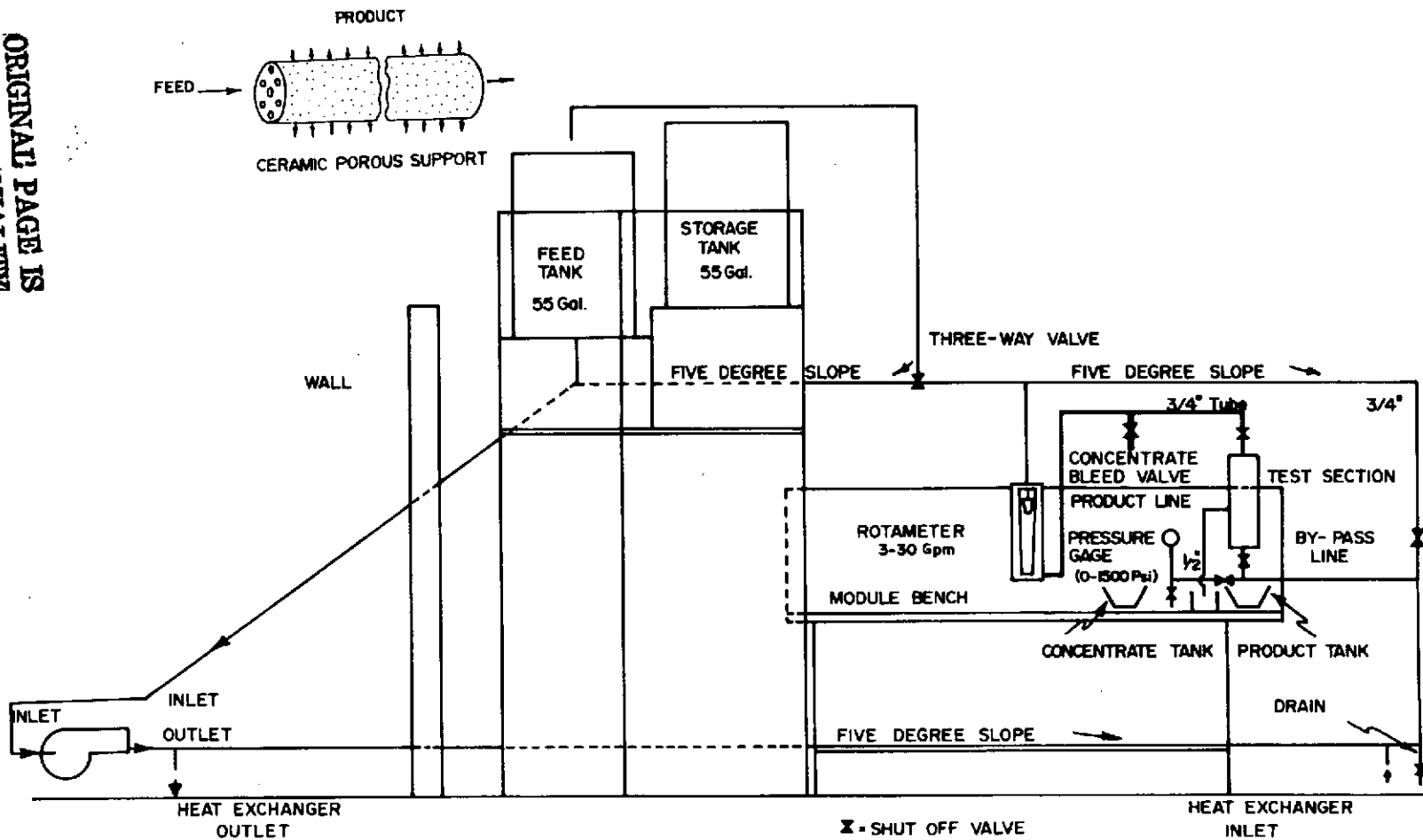

SCALE	TEST SYSTEM
1" = 1.5'	NASA PROJECT

Figure 2 System Schematic Diagram

Table I . Type and Location of Wetted Materials

Component	316 S. S.	304 S. S.	Buna-N	Viton	Tungsten Carbide	Carbon	Teflon	RTV Rubber	Natural Rubber	Glass	3603 Tygon	Ceramic
Pump	X				X	X	X					
Rotameter	X		X							X		
Piping	X								X		X	
Valves	X											
Tanks		X										
Switches	X											
Pressure Gauge	X											
Module	X		X					X				X

and the length is 35 cm. Thus, the total membrane active area is approximately 156.cm<sup>2</sup>, requiring a flow of 13.6 liters per minute to provide 10 M/sec velocity.

### 5.3.3 Instrumentation

During operation certain parameters were monitored to evaluate membrane performance. These parameters with the instrument or method used and accuracy are given in the table below.

PARAMETER	INSTRUMENT OR METHOD	ACCURACY
Module inlet pressure	Heise <sup>1</sup> (0-1000 psi) bourdon gauge	±2%
	Wika <sup>1</sup> (0-1500 psi) bourdon gauge	±2%
Feed temperature	Barber-Coleman 16 point Recorder w/Cu-Cn thermocouples	±1°C
Feed flow rate	Brooks Rotameter <sup>2</sup> 1110A-12H5BLA 3-30 GPM	±2% FS
	Brooks Rotameter <sup>2</sup> 1114-09H3BIA 0.3-3 GPM	±2% FS
Conductivity	Balsbaugh Type 100 conductivity bridge	±2% FS
pH	International Biophysics Corp. Model 180-001 pH meter	±0.1 unit
Product flow rate	Graduated cylinder and stop watch	±3%
System volume	Calibrated dip-stick	±0.25 l

<sup>1</sup> calibrated by dead weight tester

<sup>2</sup> calibrated by stop watch and scales



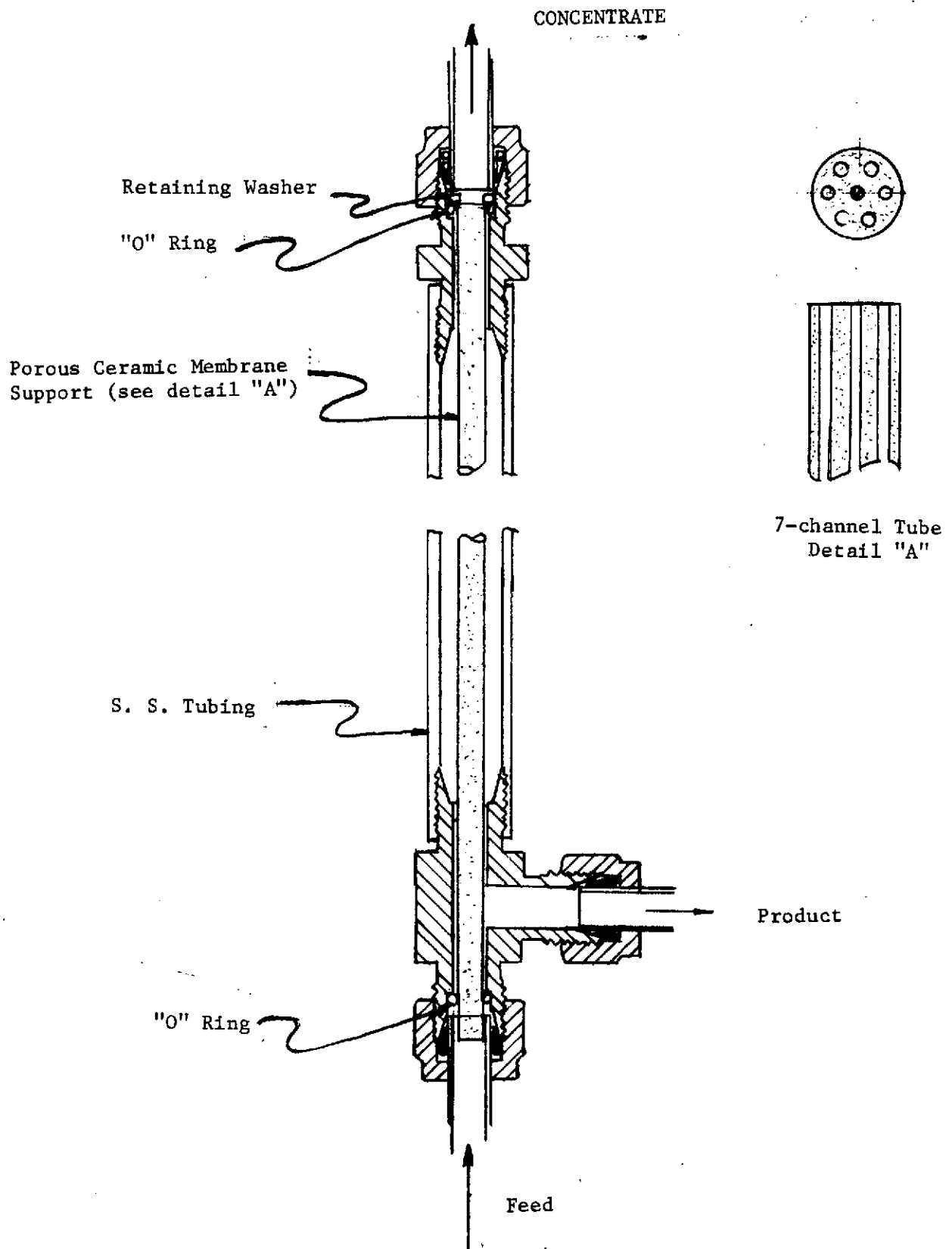

Figure 3

HYPERFILTRATION MODULE

## 5.4 Membrane Formation

### 5.4.1 System Wash

The system must be thoroughly cleaned before membrane formation is attempted. A one molar NaOH wash circulated at high velocity followed by a one molar HNO<sub>3</sub> wash, each one hour long, has proven adequate in most cases. If the system is severely contaminated the temperature can be raised to 60°C during the acid wash. The base-acid wash is followed by three or four drain and fill cycles during which all stagnant regions of the system are flushed. The system is then drained.

### 5.4.2 Formation

The module housing the membrane support is piped into the system and isolated by closing the up-stream and down-stream valves. The cleaned system is filled with a known quality of decontaminated water. (Permeate from a U.O.P. spiral-wound module with tap water as feed was used in our test.) The appropriate amounts of ZrOCl<sub>2</sub>·8H<sub>2</sub>O and NaCl are added producing a 10<sup>-4</sup> molar and 0.05 molar concentrations respectively. The pump is then turned on with all flow passing through the by-pass and the pH is adjusted to 4.0 plus or minus 0.2 by adding HCL or NaOH. The circulating fluid is introduced to the module gradually until the required velocity and pressure are achieved, usually 5 M/sec and 65 atmospheres. Conductivities of the feed and product are monitored until rejections reach 30 to 40%. If rejections do not reach this level in a reasonable length of time additional zirconium oxychloride can be added to double or triple the zirconium concentration.

The pH is adjusted to 2.0 and 50 ppm polyacrylic acid (PAA) is added and the solution is circulated past the support for 1/2 hour. The pH is raised to 3.0 and circulated for another half hour. This process is repeated in unit increments to a pH of 7 or 8 and the membrane is considered formed. At this point the conductivity rejection should be greater than 90% and the flux between 0.1 and 0.4 cm/min.

### 5.4.3 Regeneration

If rejections are considered unacceptable at the end of the formation, or if the performance has declined, a regeneration can be attempted. The pH is reduced to 2.0, PAA is added, and the pH is raised in unit increments of 30 minutes duration to a pH of 7 or 8. PAA may be added in amounts from 0 to 50 ppm for this procedure, with a full 50 ppm addition being normal. This usually results in a higher rejection and lower flux.

### 5.4.4 Re-use of Substrate Tubing

No reliable methods were determined which will allow the chemical removal of the residue of membrane from the support. The type of tube used in this test is no longer in production, and only a limited number were available. Therefore in reusing the tubes, they were fired in an air atmosphere furnace to 700°C for 2 to 3 hours to remove the residue. This procedure provided tubes which had the same permeability as new tubes. No serial record of tubes was kept to determine the effect of re-use on performance. However no irregularities in tube performance that might be ascribed to the firing process were generally observed.

## 5.5 Summary of Operations

Appendix B is a table which summarizes the activity during the performance of this work. Some seventeen membranes were attempted. Many of these failed due to fracture of the ceramic support. Others exhibited inferior performance and were discarded. Finally others were formed and stored as insurance in case of further tube fractures. These were extant at the test end.

Figure 4 shows the time line during the parametric test of 1 through 3 July 1974. This test began with the production of 14 liters of product to establish an initial elevated concentration level. After the desired concentration level was reached, concentrate was released at a rate of 3 units concentrate per 5 units product. This ratio was designed to hold the solute concentration essentially constant. The test proceeded through pressure and temperature variations to the 96°C temperature level at which time the pump lost suction. Upon restart and stabilization at 93°C a test point was completed. The loop was then shut down briefly for changeover to a smaller flowmeter. Approximately 2.2 liters of concentrate were lost during this maneuver, requiring operation with zero concentrate removal for a period to regain the desired concentration level. At a point 90 percent through run 9, the feed supply was consumed, and additional feed, not identical to that previously used, was administered. Run 10 continued on this second feed batch.

After a brief start on the concentration run which followed the parametric runs (1-10), we experienced a pump seal failure and terminated further activity. Upon repair and resumption of activity the concentration run was performed to about 93 percent recovery of initial feed volume. The same membrane was used in both the parametric and concentration tests.

Upon receipt of the pre-treated urine from Houston we evaluated the membrane performance to be lower than desirable and prepared to remove and replace the membrane and its support. Inspection revealed a large quantity of lint which had clogged the inlet end of the tube nearly to complete closure (visually). Reasoning that the reduced performance could be due to the almost certain reduction of pressure caused by the obstruction, the cleaned tube was retested. However, no significant performance increase was immediately registered and a new membrane was added.

The urine run was initiated and carried 30 percent to completion at which time the pump seal leaked forcing shutdown due to loss of fluid. The seal failure was not identical to that previously experienced and also was not due to a factor obvious upon inspection.

## 6.0 DISCUSSION OF RESULTS

### 6.1 Data Analysis Procedures

The pressure, temperature, and velocity parametric data were observed during a 19 hour period. The major events were chronologically related as indicated in Figure 4, which shows the pressure, temperature, velocity, product flow rate, and collection periods for the samples. Immediately prior to

ORIGINAL PAGE IS  
OF POOR QUALITY

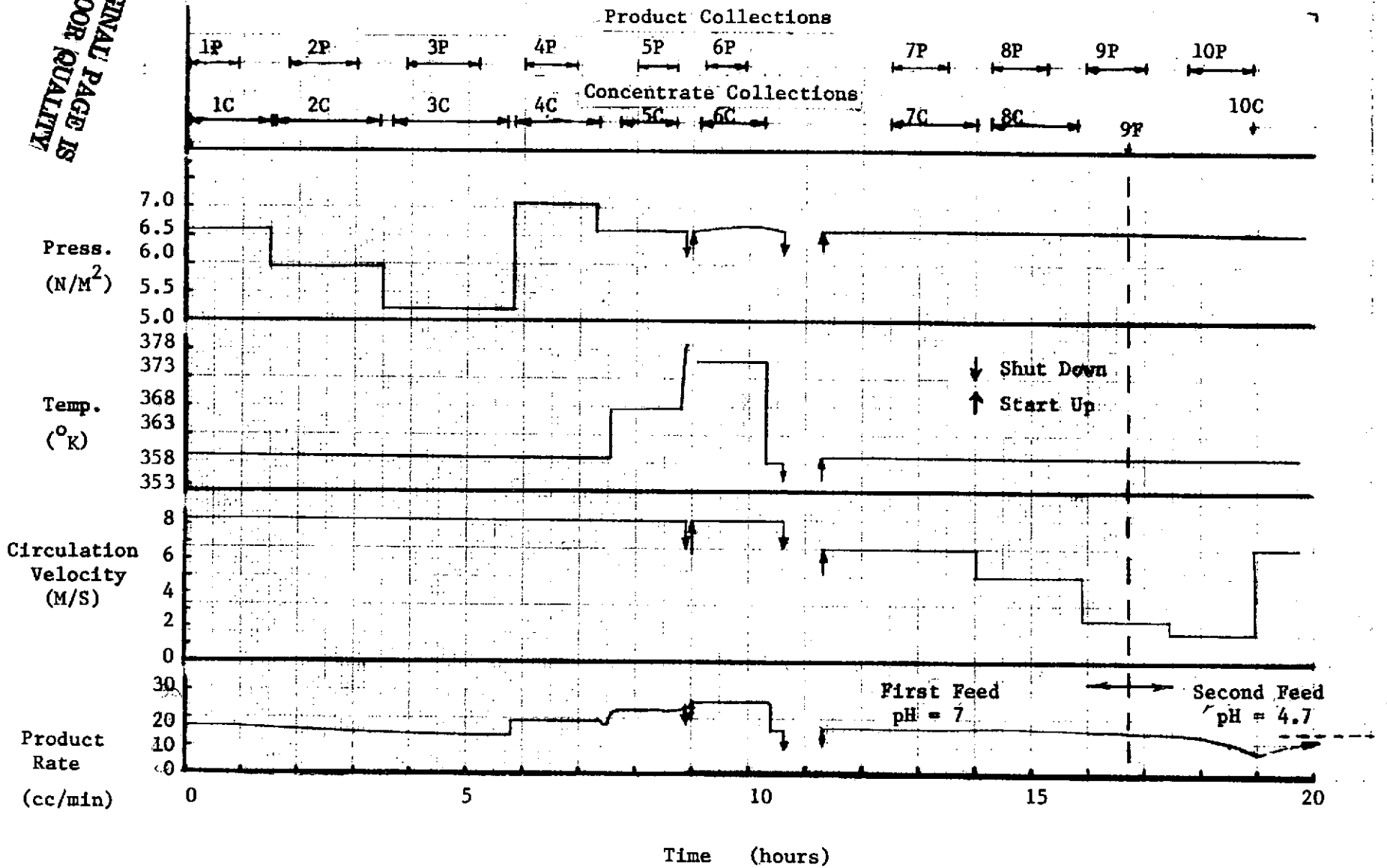

Figure 4 . Major Event Chronology During Parametric Tests

the period covered by this plot, the test facility had been operated with only product flow withdrawn to increase the loop concentration. Some 14 liters of product were withdrawn, producing a concentration factor of about 2.4 in the 10-liter active loop volume.

During the entire 19 hour test period, concentrate was withdrawn from the circulating loop at 60 percent of the product flow rate. The withdrawals of concentrate were made at 15 minute intervals, approximating continuous outflow. Thus, the collection interval for concentrate samples was 66 percent longer than the respective collection interval for product samples. Collection of product water was generally delayed long enough to allow the "old" product to be purged from the system volume between the sample port and the membrane. Experience gained during system checkout had indicated that about 100 ml. of product would insure the purge of the "old" product.

A short interruption in the continuous operation of the test occurred between sample numbers 5 and 6, due to a temperature over-shoot resulting in the loss of pump suction. A longer shutdown occurred preceding point 7 when a change to a smaller flowmeter, required for the low velocity runs, was made. The loss of water during this equipment change required a reconcentration period of over one hour during which only product was withdrawn from the system. Near the end of the collection of the sample number 9, a new batch of feedwater was added to the system reservoir. This batch of feedwater was not identical to the first, resulting in some difficulty in interpretation of test results.

The data taken for each sample are shown in Table II. These data are primarily the result of analysis conducted at NASA-JSC, with some results obtained on line at Clemson, the C.O.D. by a local contractor. Accuracy of analysis are as indicated in Appendix C for the samples taken. Many of the feed and concentrate samples are difficult to extract a representative sample from, and production of filtrate was extremely difficult. An internal consistency check of C.O.D. with T.O.C. should be that T.O.C. multiplied by a molecular weight ratio (about 2.7) should be equal to or greater than the C.O.D. level. (Greater than because of constituents which do not oxidize with potassium dichromate; for example, urea.) As noted, the data do not afford a universal check according to this criterion. It is believed that the C.O.D. procedure yields greater accuracy if the result is known a priori, or at least if a realistic upper bound can be established. Thus the repeated tests for C.O.D. have the benefit of hindsight and therefore are more accurate.

Internal consistency of the data may also be examined, using mass balance of the various solutes. An attempt at depicting this is shown in Figure 5 for  $\text{NH}_3$  and T.O.C. The mass balance can be used to determine the product concentration which would yield the measured concentrate concentration with the measured feed. Such a procedure is impractical due to the magnification of the concentrate variation on the predicted product concentration. For example, a ten percent variation in concentrate concentration between successive samples implies about a one hundred percent variation in product concentration. However, the measured product concentration can be used to critique quite effectively the concentrate and even the feed concentration values, as follows. The T.O.C. loop concentration at the beginning of the test should have risen from 124 (feed concentration) to about 283 at an average rejection rate of 0.95, using

Table IIa Analysis of samples for selected Solutes

Table IIa Continued

Run	Conc(C) or Prod(P)	Press ( $10^{-4}$ xN/M <sup>2</sup> ) (psig)	Temp (°K)	Vel (m/sec)	Cond. (μmho/cm)	TOC (ppm.)	COD (ppm.)	NH <sub>3</sub> as N (ppm.)	Urea (ppm.)	pH	Inorganic Carbon (ppm.)
	FEED FOR RUNS 1 - 9 2/3				530						
1	C	950	349	7.7	1750	124	-	24	36	6.44	16
1	P	668	349	7.7	140	260	657	77	90	6.47	25
2	C	850	349	7.7	1800	8	90	9	19	7.35	8
2	P	597	349	7.7	170	257	828/475	72		6.64	27
3	C	750	348	7.7	1800	12	100	7	21	7.20	9
3	P	527	348	7.7	180	245	657	59	69	6.35	27
4	C	1040	348	7.7	1700	7	109	8	18	6.69	12
4	P	724	348	7.7	150	244	600/375	64		6.36	26
5	C	950	358	7.7	1900	10	81	7	15	7.17	10
5	P	668	358	7.7	195	244	486/359	60	55	6.37	25
6	C	668	366	7.7	1900	10	90	8.2	18	6.65	12
6	P	668	366	7.7	230	275	1000	60		6.42	20
7	C	668	350	6.1	1980	26	67/33	8	15	7.00	6
7	P	668	350	6.1	185	260	847	59	50	6.33	25
8	C	668	350	4.5	2050	11	84/42	7	15	6.47	10
8	P	668	350	4.5	200	324	419/481	77		6.38	16
9	FEED FOR RUNS 9 2/3 - 10				660	10	19/44	7	12	6.5	12
9	P	668	349	2.3	220	121	--	33	58	6.69	39
10	C	668	349	1.5	1600	17	44/33	9	18.5	6.59	8
10	P	668	349	1.5	190	190	438	25	55	6.16	20
11	C	668	349	2.3	870	14	--	13	40	7.28	15
11	P	668	349	2.3	84	212	552	17		8.47	13
12	FEED		349		640	20	19/22	3	46	9.08	7
12	P	668	349	7.7	57	183	1066	31		6.92	27
13	C	674	346	3.0	905	25	50/54	.6	46	7.13	6
13	P	660	351	3.0	120	203	1485	25		6.68	17
14	P	668	351	3.3	160	36	124	5	50	9.28	7
15	P	668	352	3.0	285	36	129	5	75	9.37	8
16	P	674	352	3.0	485	60	185/185	7	63	9.38	17
17	P	671	351	3.0	660	77	257	26	55	8.88	17
18	P	674	351	2.8	750-800	70	257	18	55	6.51	20
20	C	-	-	-	-	128	294/244	16	72	8.82	12
22	C	-	-	-	-	4421	--	82	255	7.5	29
						3673	10,728	85	230	7.5	27

Table IIb. Complete Analysis of Selected Samples

Determination	12(Feed)	13P	15P	18P	20C	1F	3P	5P	7P	9P	11P
Chromium as Cr <sup>+6</sup> , ppm	100			1	1000	100					
Silver as Ag, ppm	.01			.01	.058	.017					
Zinc as Zn, ppm	.54			14		.34					
Fluoride as F, ppm	.04			.066	.275	.28					
Nitrate as NO <sub>3</sub> , ppm	2	.2	.2	.69	.49	.75	.41	.25	.2	.38	.26
Sulfate as SO <sub>4</sub> <sup>-2</sup> , ppm				8	4000	45					
Chloride as Cl, ppm	192	16	49	190	1700	221	24	48	39	45	6
Conductivity (umho/cm)	640	120	285	750	---	1750	180	195	185	220	84
TOC, ppm	183	36	60	128	4421	124	7	10	11	17	20
COD, ppm											
NH <sub>3</sub> , ppm	31	5	7	16	82	24	8	8.2	7	9	3
Urea, ppm	44	50	63	72	255	36	18	18	15	18.5	46
pH	6.92	9.28	9.38	8.82	7.5	6.44	6.69	6.63	6.47	6.59	9.08
Inorganic Carbon, ppm	27	7	8	12	29	16	12	12	10	9	7

for example equation 2 of Appendix A for predictive basis. The loop concentrations were measured at 240 to 270 for the most part, (run numbers 1-7) indicating by the strength of several measurements that the feed reading tended to be high by perhaps 10 ppm. So the feed could actually have been about 115 ppm rather than 124 based on this observation. Assuming that run 1 started either at 250 or 270 (T.O.C.), that the feed analysis was incorrect by the aforementioned amount, and that the product concentrations are known without error, the curves of Figure 5 are determined. Either of these curves agrees reasonably with the measurements, with the lower estimate (starting from 250) actually favored.

Concentrate samples 8 and 10 (no concentrate was collected in run 9) show a noticeable rise and fall in concentration level. The rise during run 8 is thought to be due almost certainly to the fact that the reservoir had emptied and no new flow had replenished the flow of product removed. During run 9, new feed was added to the reservoir resulting in dilution of loop fluid. Readings of concentrate conductivity during this period are shown in Figure 6. This figure traces a conductivity rise from the previous level of 1900 or so upward to just over 2300 before the addition of new feed. While the rise in conductivity during the collection of 8C was about 10 percent, it was not the 25 to 28 percent indicated by T.O.C. and  $\text{NH}_3$  analysis. Inasmuch as all solutes were affected by the same volumetric dilutions and compressions, and the levels of rejection were not grossly different, one would expect to produce proportional variations of each solute. Using the conductivity as a guide one would predict only about a ten percent rise in loop T.O.C. or  $\text{NH}_3$  during run 8.

After the addition of new feed, one expects to see the resulting loop concentration very quickly mix to a new value approaching the "old value" observed before run 8. This value would be expected to be maintained by new feed addition. Unexpectedly, however, the loop conductivity shows evidence that a continuing mixing with low conductivity fluid occurred driving the conductivity to a low value. A similarly low value of both T.O.C. and  $\text{NH}_3$  were registered as shown in Figure 5. The concentrate was collected at the end of the run, whereas the product was continuously collected and properly reflects production from a level of about  $\frac{3}{4}$  {10C} +  $\frac{1}{4}$  {8C} rather than production from 10C.

Figure 5 also shows results obtained for  $\text{NH}_3$ . With feed concentration of 24 ppm initially one would expect only about 53 ppm loop concentration. However, levels generally above this were observed. The possibility that the feed concentration exceeded 24 ppm is therefore considered. Beginning at levels of loop concentration of 60 to 80 ppm one predicts the curves shown in Figure 5 which do not strongly disagree with the data. Use of feed concentration of 28 ppm and initial feed concentration of 60 ppm yields consistently over the concentrating period and agree with the data as well as any curve shown.

No appropriate comparison can be made for the measured values of C.O.D. due to the relatively higher scatter. The data in Table II for samples 1C through 10C have an average value of 586, and the repeatability is not considered good. The high value anticipated for all indices on sample 8 is not indicated by either reading on sample 8. The average value of 586 should be accompanied by a value of T.O.C. of at least 217, which is observed by all data except 10C.



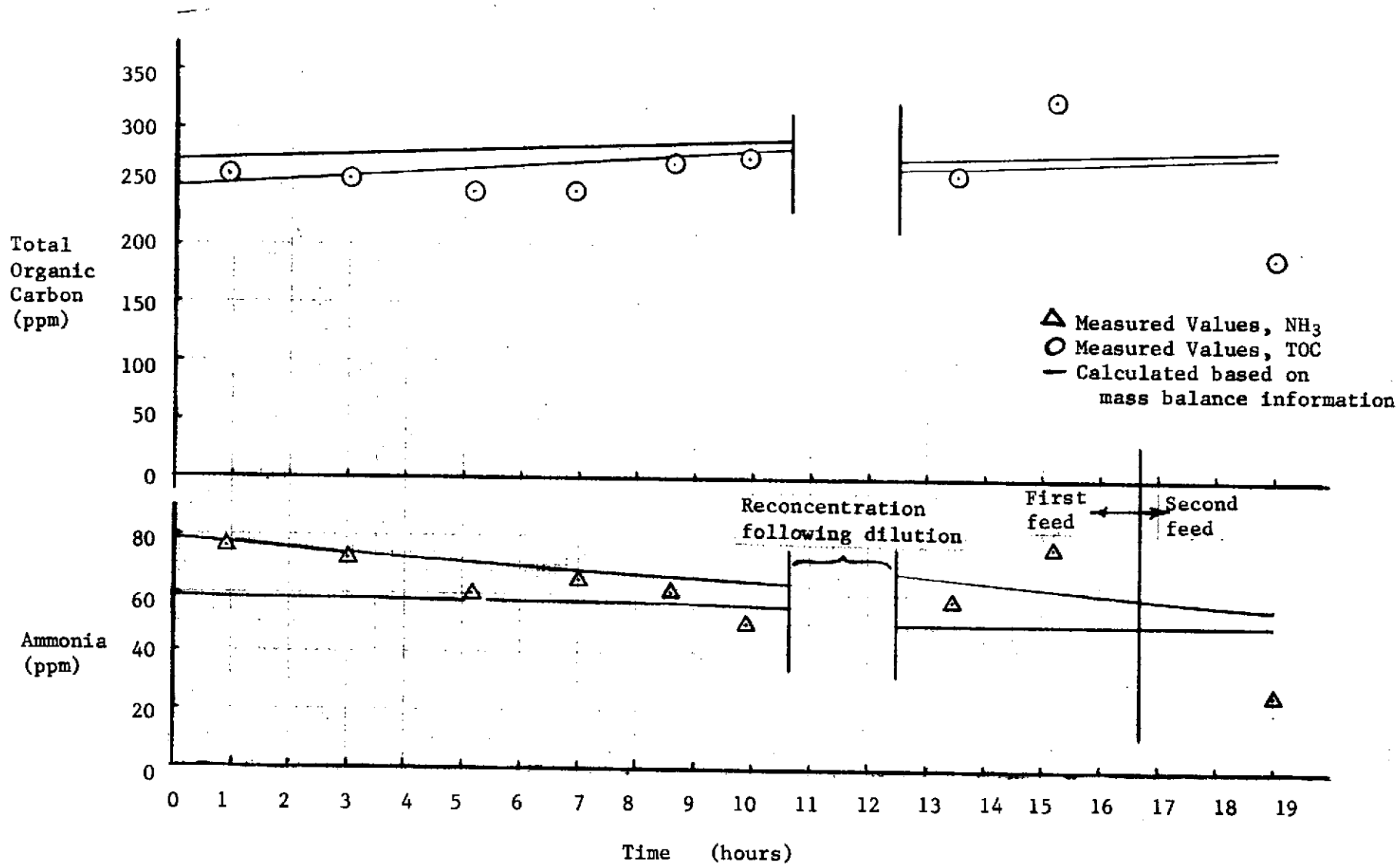

Figure 5. Predicted Concentrations of Loop Solutes

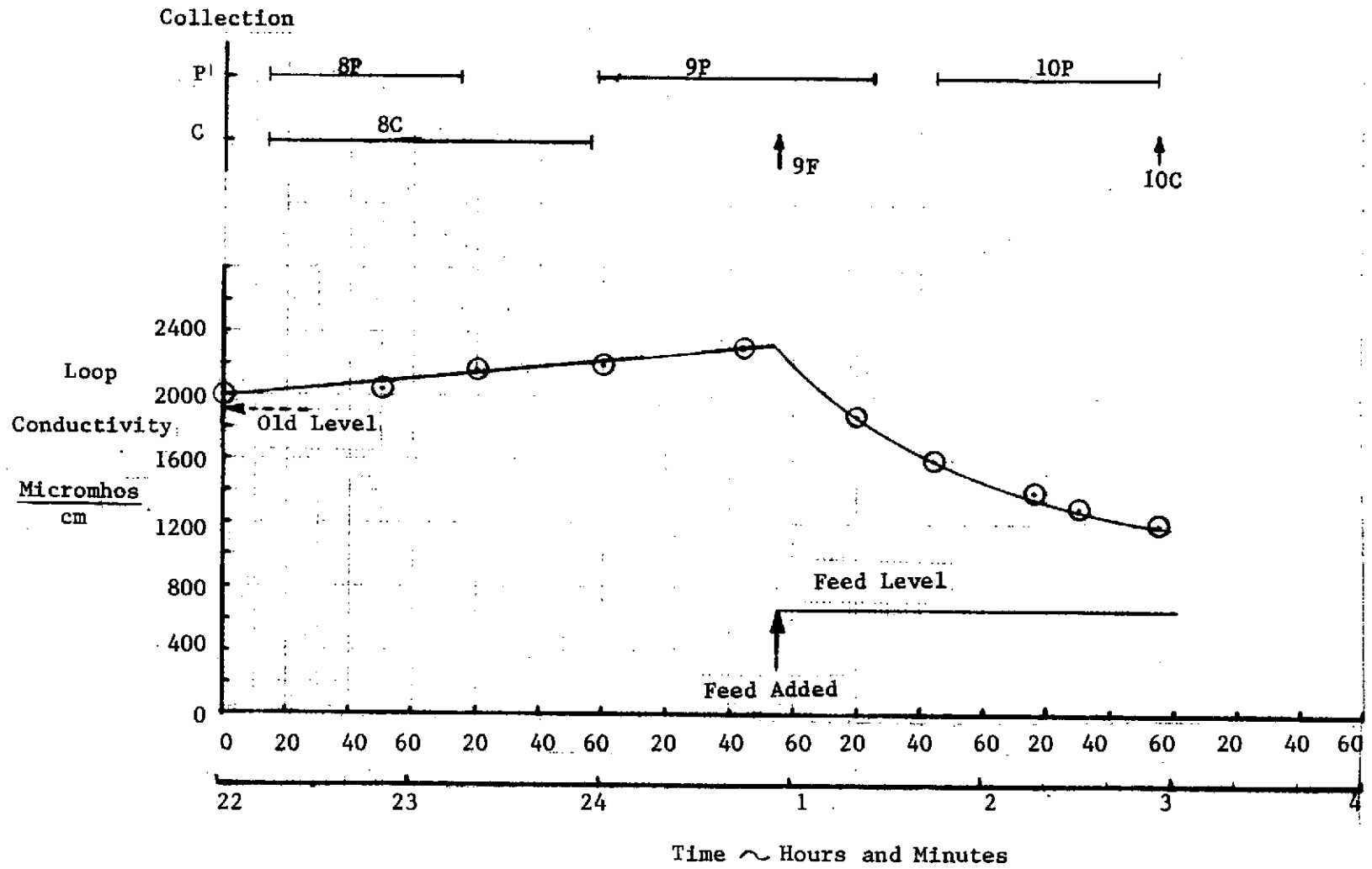

Figure 6. Concentrate Conductivity Readings During Runs 8, 9, and 10.

The concentration scan experiment was performed following the other parametric runs. The first attempt was terminated due to a loss of the pump seal after about 10 hours of running. A new seal was installed and new feedwater was generated after a four day down time. Figure 7 shows the flow rate history and observations of system content. System content was judged by the height of liquid in the feed reservoir. A second feed-water batch was added on the following day with care exerted to insure that the new and old temperatures were equivalent. The integrated flow rate measurements were fitted readily to the reservoir volume observed and allowed extension past the "empty" point to the end of the test, at which time the fluid was drained and measured. In all 9.33 liters of concentrate remained at the end of the test. The data in Figure 7 have been used to determine the recovered fraction R from:

$$R = \frac{\text{liters product produced}}{\text{liters initial volume}} = \frac{\text{initial volume} - \text{system content}}{\text{initial volume}}$$

A concentration factor is useful and is defined by

$$\frac{1}{1 - R} = \frac{\text{initial volume}}{\text{system content}}$$

This factor will be used in several of the following graphs. Discrete values are given in Table III for each product sample. Feed samples were collected at the beginning of testing (12C = 12F) and after mixing the second feed with the slightly concentrated earlier feed (denoted 13C). Product sample 13 was not collected at the same time as feed sample 13, but later as shown in Figure 7.

The flow rate history shown in Figure 7 is highly interesting. The membrane is that used for the earlier tests and (referring to Figure 4) had started at product flow about 17 cc/min. During the test, upon the addition of feed (in run 9) the flow declined over about one hour to 9 cc/min. At the initial point in the concentration run the flux had recovered 75 percent toward its original value. Then within 12 hours (no data were taken earlier) the flux had again dropped noticeably. By the end of 36 hours, the flow had risen to a greater rate than that measured at the start of the concentration run. Again, following the addition of new feed, the flow dropped and recovered. The recovery this time was to a level of about 30 cc/min, a value which represents 2/3 of the temperature-corrected flux at formation. Thus, a considerable but incomplete flux recovery had transpired by the end of the concentration test.

Fluid was not withdrawn during the concentration run because it is difficult to account for its withdrawal when calculating the effective recovery; and near the end of the test, a one-liter sample constitutes a significant (5 to 10%) fraction of total fluid. Because of this fact it is necessary to reconstruct the concentration values of solutes in the loop from mass balance information. As shown in Appendix A and elsewhere, the loop concentration ( $C_c$ ) is related to the feed concentration ( $C_f$ ) and recovery (R) by

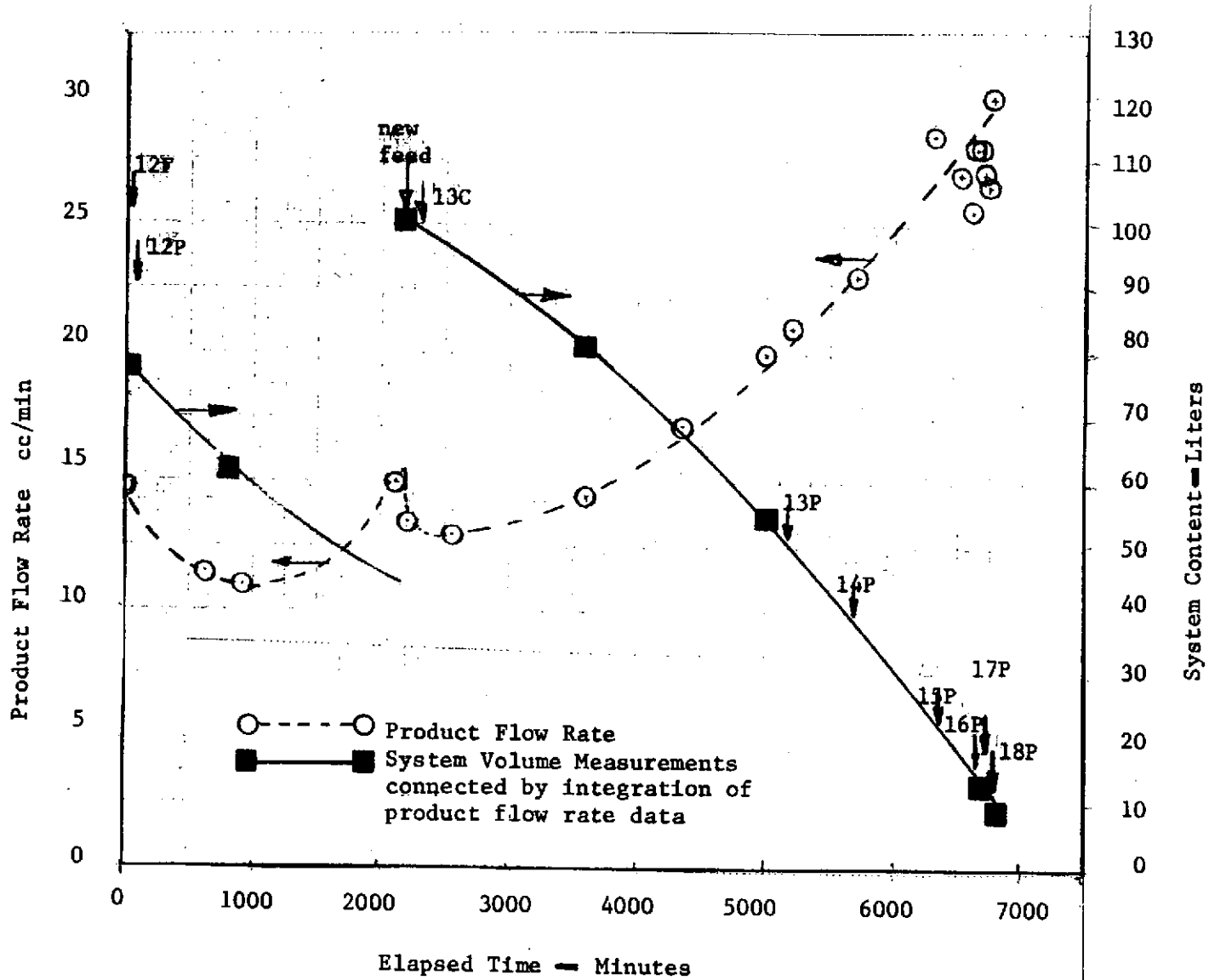

Figure 7 Flow and System Content During Concentration Run

Table III. Concentration Factor for Various Product Samples

<u>Sample Number</u>	$\frac{1}{1 - R}$
12P	1.0
13C	1.32
13P	2.62
14P	3.39
15P	5.83
16P	9.85
17P	11.0
18P	12.3
20C } 21C } 22C }	14.4

$$\frac{C_c}{C_f} = \left( \frac{1}{1 - R} \right)^\gamma \quad (1)$$

where  $\gamma$  is the rejection  $1 - C_p/C_c$ . Such a relation should plot as a straight line on a plot of  $\log C_c/C_f$  versus  $\log 1/(1 - R)$ . Also, at any time, the product must be described according to

$$\frac{C_p}{C_f} = (1 - \gamma) \left( \frac{1}{1 - R} \right)^\gamma \quad (2)$$

Here again  $\log (C_p/C_f)$  versus  $\log \left( \frac{1}{1 - R} \right)$  is anticipated to be a straight line if  $\gamma$  is constant. The data for T.O.C. are presented in Figure 8 according to these relations. One seeks to determine an average value of  $\gamma$  which causes mutual agreement between the product and feed and the residual concentrate and feed. For T.O.C., the residual concentration is beyond the highest possible value, a condition indicating greater total organic content after the test than before. In Figure 8 two values of feed T.O.C. are employed: the open symbols use the value associated with the higher of the two feed batches, the filled symbols denotes value calculated as the average of two feed batches, judging from sample 13C taken after mixing the second feed batch. The product and feed comparison indicates that a value of 90 or 92 percent approximate the results. These results (92 percent on product data alone and 100 percent on concentrate data alone) do not close the material balance entirely. The feed uncertainty bias can be removed by comparing product samples with only the residue. The maximum value of  $C_c$  is that of the residue and occurs at  $R$  max, so

$$\frac{C_{c \max}}{C_f} = \left( \frac{1}{1 - R \max} \right)^\gamma \quad \text{and} \quad (3)$$

$$\frac{C_c}{C_{c \max}} = \left( \frac{1 - R \max}{1 - R} \right)^\gamma \quad (4)$$

The value of product compared to maximum concentrate is then

$$\frac{C_p}{C_{c \max}} = (1 - \gamma) \left( \frac{1 - R \max}{1 - R} \right)^\gamma \quad (5)$$

The relation also plots a straight line in coordinates

$$\log \left( \frac{C_p}{C_{c \max}} \right) \quad \text{vs} \quad \log \left( \frac{1}{1 - R} \right)$$

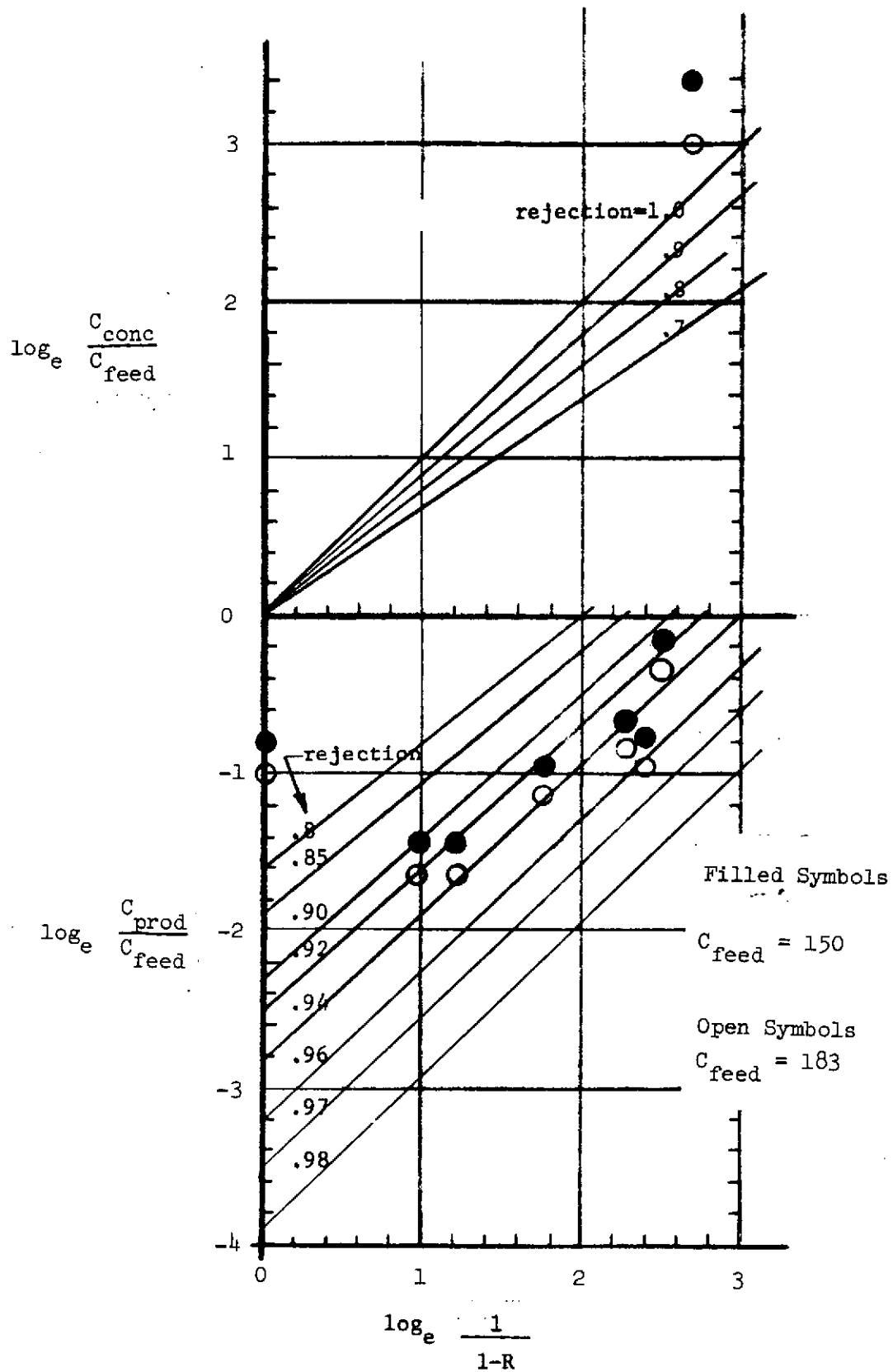

Figure 8 Product Feed and Concentrate Self-Consistency Comparison for Total Organic Carbon

The T.O.C. data are shown in Figure 9 with open symbols for the lower and filled symbols for the higher value of concentrate residue. This approach is felt to be more accurate (assuming equal fidelity of the analysis) for the critical, high-concentration end of the test. The overall indications are that T.O.C. rejections of about 96 percent were achieved.

An identical procedure has been followed for the ammonia data, as shown in Figures 10 and 11. In the case of ammonia, the concentration of residue fluid is lower than would be anticipated based on feed and product data. For urea, only the values of product-to-residual concentration are displayed in Figure 12.

The foregoing procedure has been used to reconstruct a variation of loop concentration which is believed to be basically accurate. Specifically, values of 0.96 and 0.8 and 0.6 have been used for the average rejections of T.O.C.,  $\text{NH}_3$ , and urea respectively. The concentration which leads to the measured residue values is used; i.e. the concentrations are computed from equation 4. This leads to concentration estimates which are believed to be more reliable at the higher concentration levels, since the feed concentration is ignored in favor of the residue concentration.



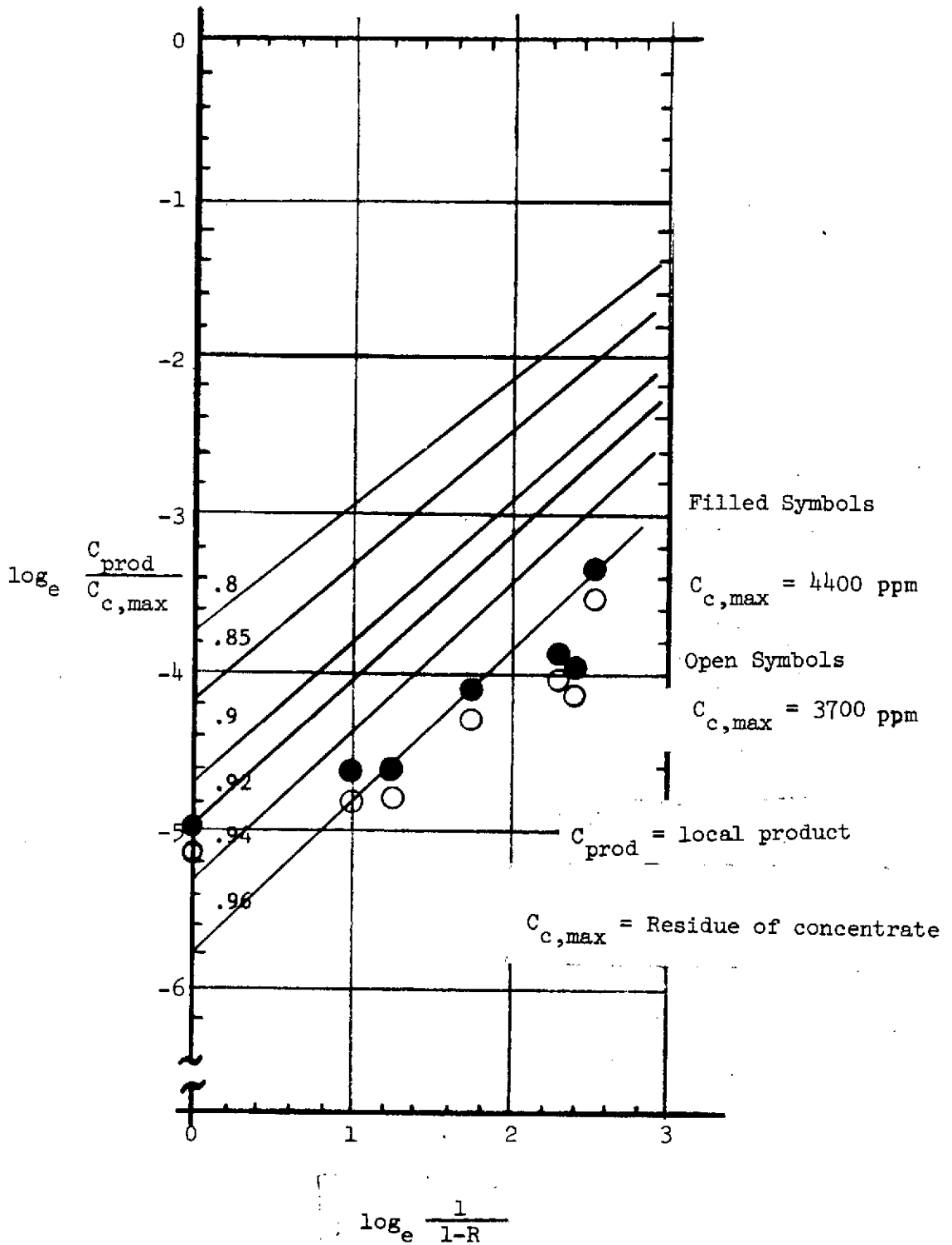

Figure 9 Product and Residue Self-Consistency Comparison for Total Organic Carbon

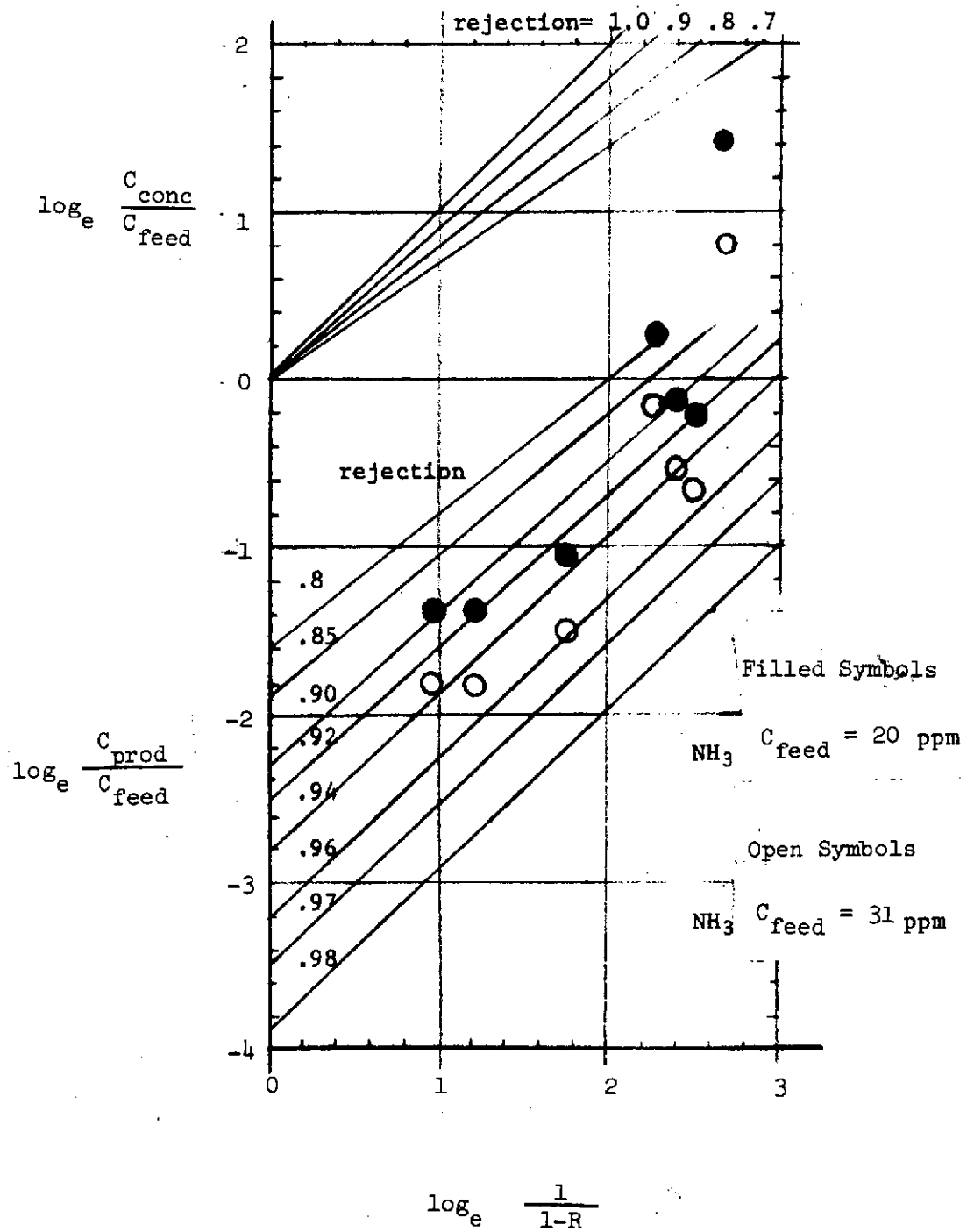

Figure 10 Product, Feed and Concentrate Self-Consistency Comparison for Ammonia

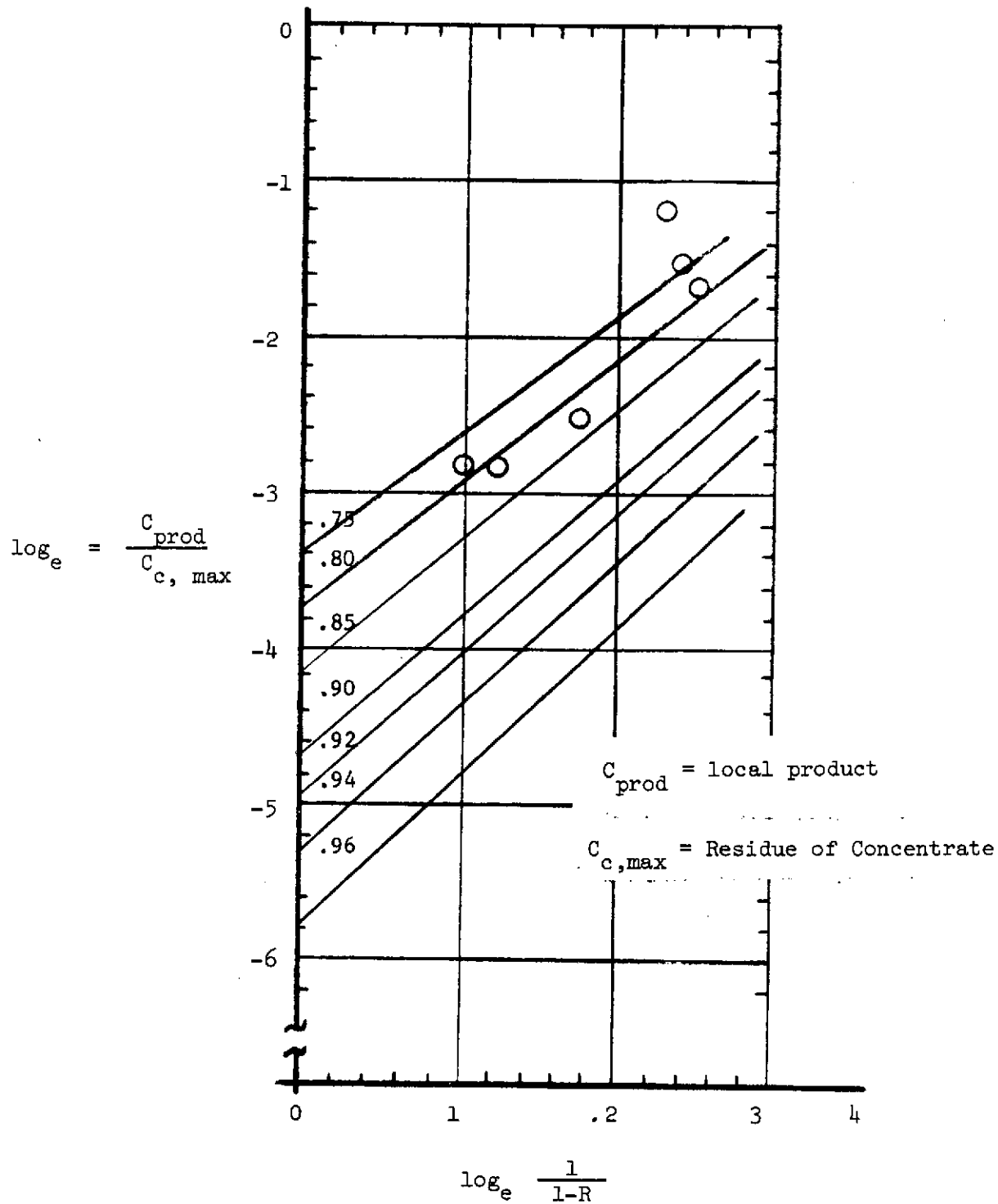

Figure 11 Product and Residue Self Consistency Comparison for Ammonia

ORIGINAL PAGE IS  
OF POOR QUALITY

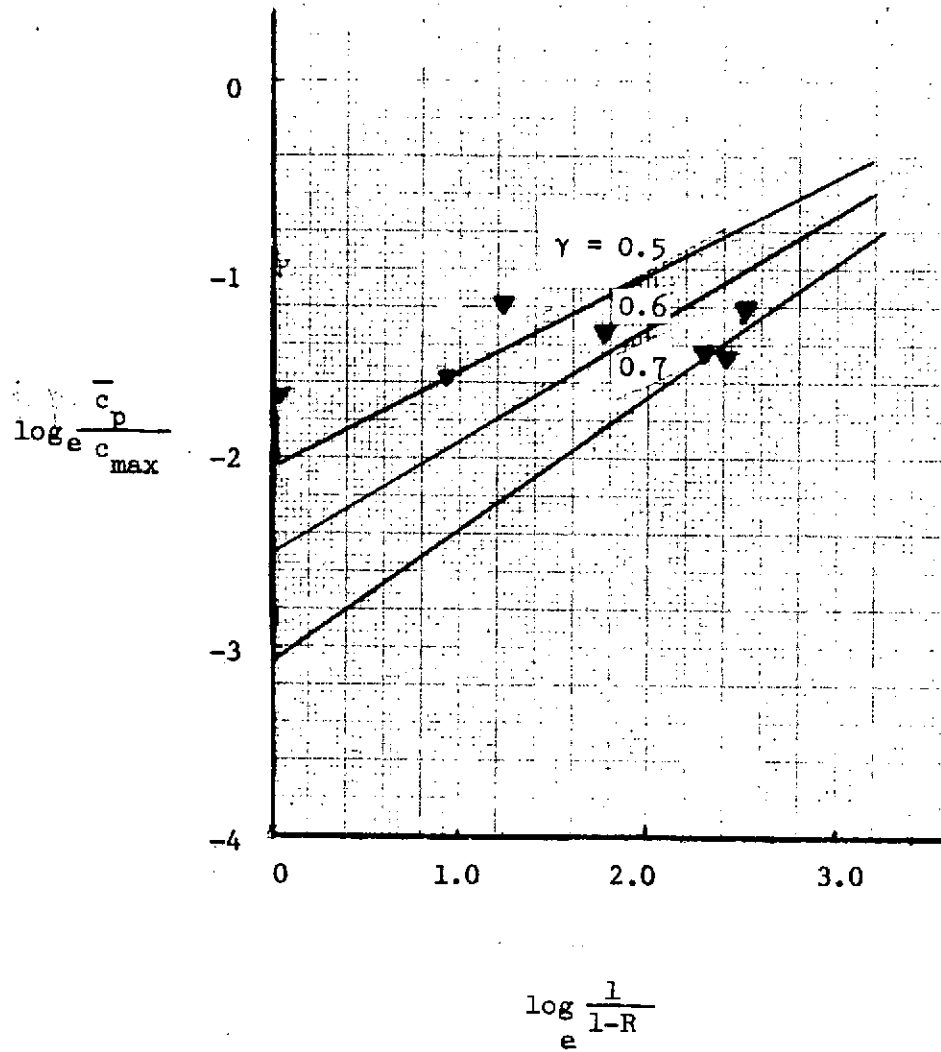

Figure 12 Product and Residue Self Consistency Comparison for Urea

## 6.2 Results

The parametric tests were carried out in two parts. During a 19 hour period terminating at 0300 hours on July 3, the systematic variations of pressure, temperature, and circulation velocity were accomplished. After some system repairs, the concentration scan was carried out on July 8 through July 13.

The range of variations were selected, consistent with system capabilities, to cover the expected range of interest for the design of a wash-water recovery system. For example, temperature was not varied below 348°K, since it was expected that considerations of sterilization precluded system designs for lower values. Preliminary analyses for optimum system design indicated high pressure and low velocity. Thus the range of variation from the standard was weighted accordingly. Based on previous observations with shower water and general experience with dynamic membranes, the standard conditions were:  $V = 8.2$  M/sec;  $T = 348^{\circ}\text{K}$ ;  $P = 6.55 \times 10^6$  N/M<sup>2</sup> (950 psig) and  $C = 2.5 \times$  feed concentration. Only one parameter was varied at a time from these conditions.

Of course, a perhaps significant variable about which little is known is time. In each parametric scan the tests were started and concluded at the reference conditions. No significant variations were noted that are attributed to time over the three or four hours elapsed during each parametric scan. In Figure 4, a presentation of the major event chronology, the sequence of variations during the parametric tests of pressure, temperature, and velocity is indicated. Also noted are the times during which samples of the product and concentrate were collected. These samples are the basis for the determination of membrane performance, with respect to the rejection of certain key solutes in the shower water. In several figures, the results of the parametric scans are presented in terms of the observed rejections of total organic carbon (T.O.C.), conductivity, ammonia, chemical oxygen demand (C.O.D.), and urea.

### 6.2.1 Pressure

In Figure 13, the observed rejections and product flux are plotted against pressure. During this scan pressure was varied from  $5.25 \times 10^6$  N/M<sup>2</sup> (750 psig) to  $7.1 \times 10^6$  N/M<sup>2</sup> (1040 psig). To indicate the probable trend to lower pressure, data from hyperfiltration of industrial wastewater are shown. The observed rejections are apparently constant over the range of pressure investigated. However, the rejection is expected (2) to increase with pressure approaching an asymptotic value. Consequently, it is probable that performance slightly above the rejection levels indicated can be achieved.

The flux is indicated to be a linear function of pressure going to zero at zero pressure. The molality of solutes is quite low in the shower water; hence no significant shift in a zero intercept due to osmotic pressure is expected. The results with the industrial wastewater also indicate a linear relationship with zero intercept. The indicated levels of observed rejection for the several parameters are:

- (1) 96% for T.O.C.
- (2) 91% for conductivity
- (3) 87% for ammonia
- (4) 84% for C.O.D.
- (5) 76% for urea

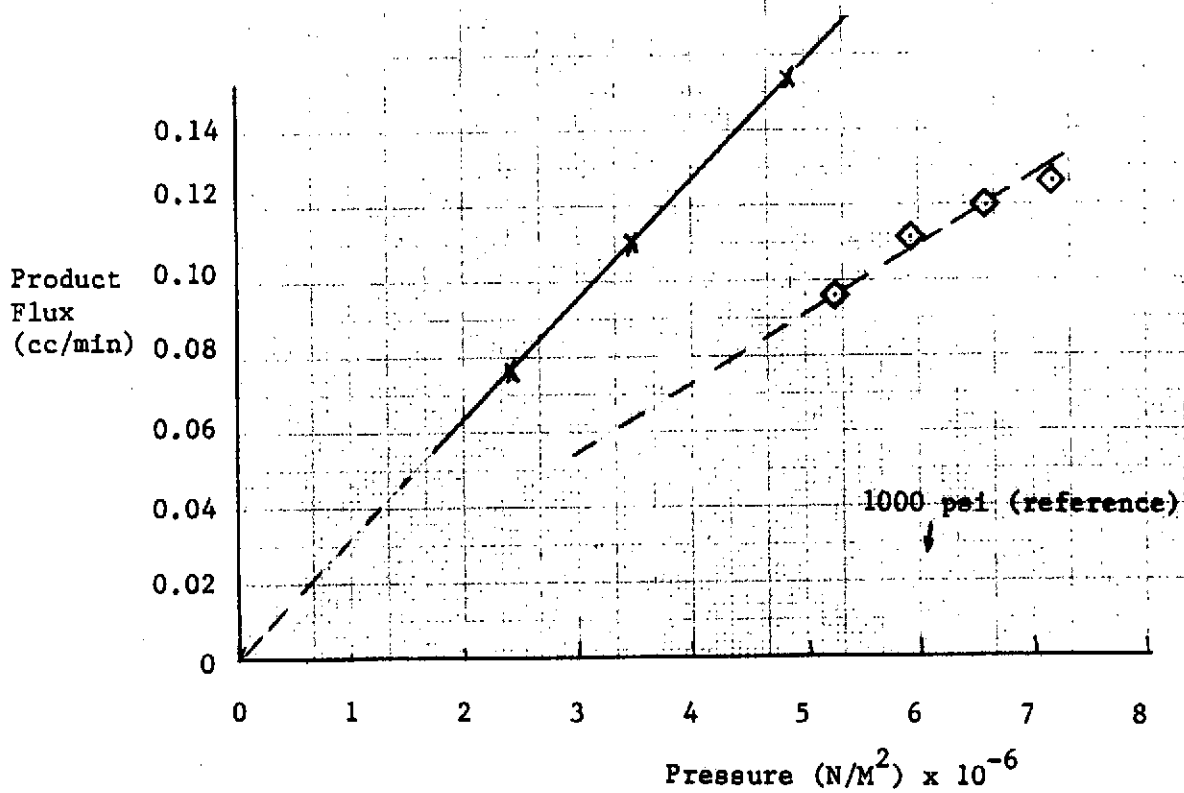
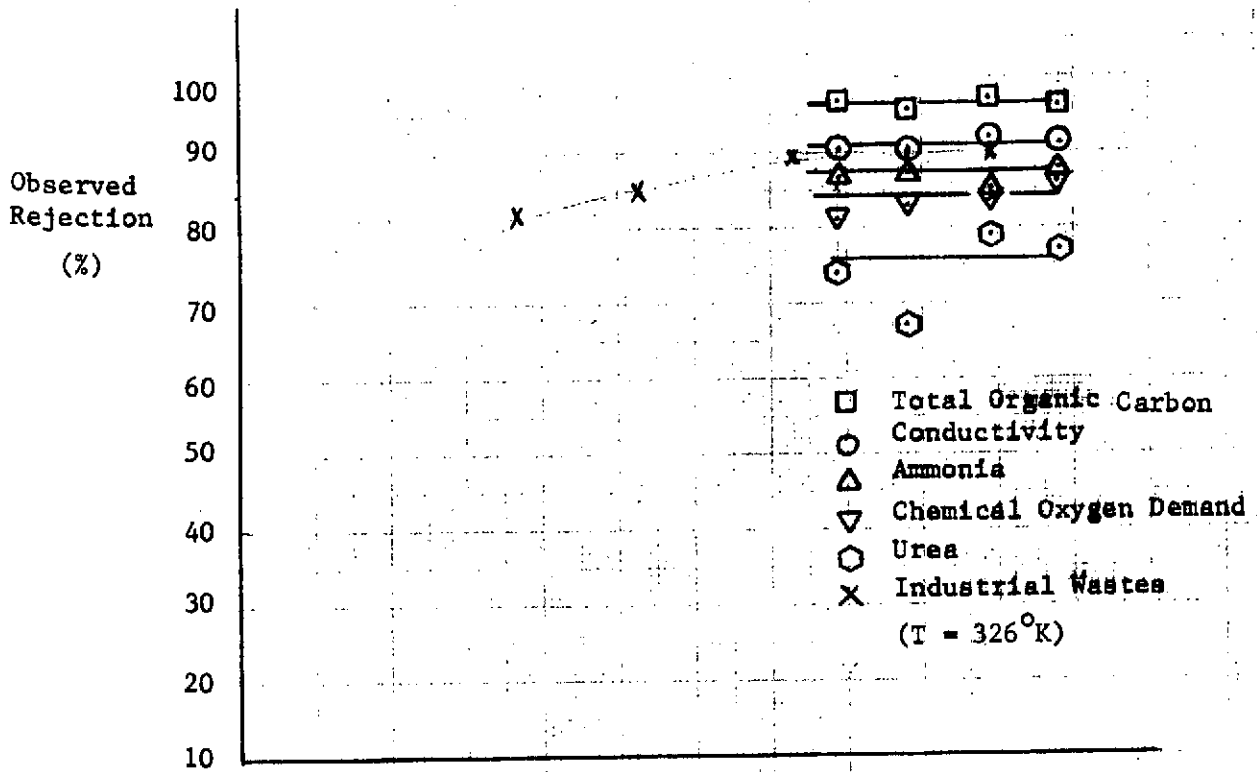

Figure 13. Performance Variation with Pressure  
 (U = 8.2 M/s, T = 348°K, C = 2.5 x feed)

### 6.2.2 Velocity

In Figure 14, the observed rejections and product flux are plotted against velocity. During this scan velocity was varied from 8.2 M/S to 1.7 M/S. Two types of velocity effects are important in hyperfiltration. The short term effect, concentration polarization, (a mass transfer phenomenon) is indicated by a decreased observed rejection. Longer term effects due to surface "fouling" or "scale" build-up are expected to be related to circulation velocity as well as temperature. Unfortunately, several unscheduled events occurred that cloud the interpretation of the observed results.

At the start of the velocity scan, it was necessary to go through a re-concentration period due to dilution of the loop feed resulting from a change of flowmeters. Some 5.5 hours later, in the middle of the test at 2.5 M/S, the system volume had to be replenished with a second batch of shower water (see Figure 4). The pH of the new material was 4.7 compared to the pH = 7 for the original. The indicated time dependence of flux makes the interpretation of the results from the tests at 2.5 M/S and 1.7 M/S uncertain.

For the conditions of these tests little concentration polarization effect was expected. All the observed rejections confirm the lack of dependence upon velocity, certainly in the range of 2.5 M/S. The indicated much lower rejections for ammonia and urea are of particular concern since these solutes are the limiting factors for product water reuse. It is felt that the phenomena indicated at these lower velocities are more related to the addition of new feed than to low velocity.

Unfortunately, there is no completely satisfactory explanation for the lower urea and ammonia rejection. Since the minimum permissible velocity is very critical to module and system design, further explanation of the low velocity results is essential. Bearing in mind that long term velocity effects have not been investigated either, it seems reasonable to conclude that the present results confirm expected short term velocity effects on observed rejections.

### 6.2.3 Temperature

In Figure 15, the observed rejections and product flux are plotted against temperature. During this scan, temperature was varied from 76°C to 93°C. To indicate expected trends to lower temperatures, data from hyperfiltration of industrial wastewater is shown. The observed rejections clearly indicate a trend to decrease with increasing temperature. This is a result of the coupling of the solute flux to the water flux which is shown to increase markedly with temperature.

The data are connected by a dashed line in Figure 15. To yield further insight into the mechanism by which the water flux increases, the data are re-plotted in Figure 16 with the logarithm of flux against the reciprocal of the absolute temperature. The results in Figure 16 are suggested for predictive interpretations. Other data indicate this trend continues to at least 25°C.

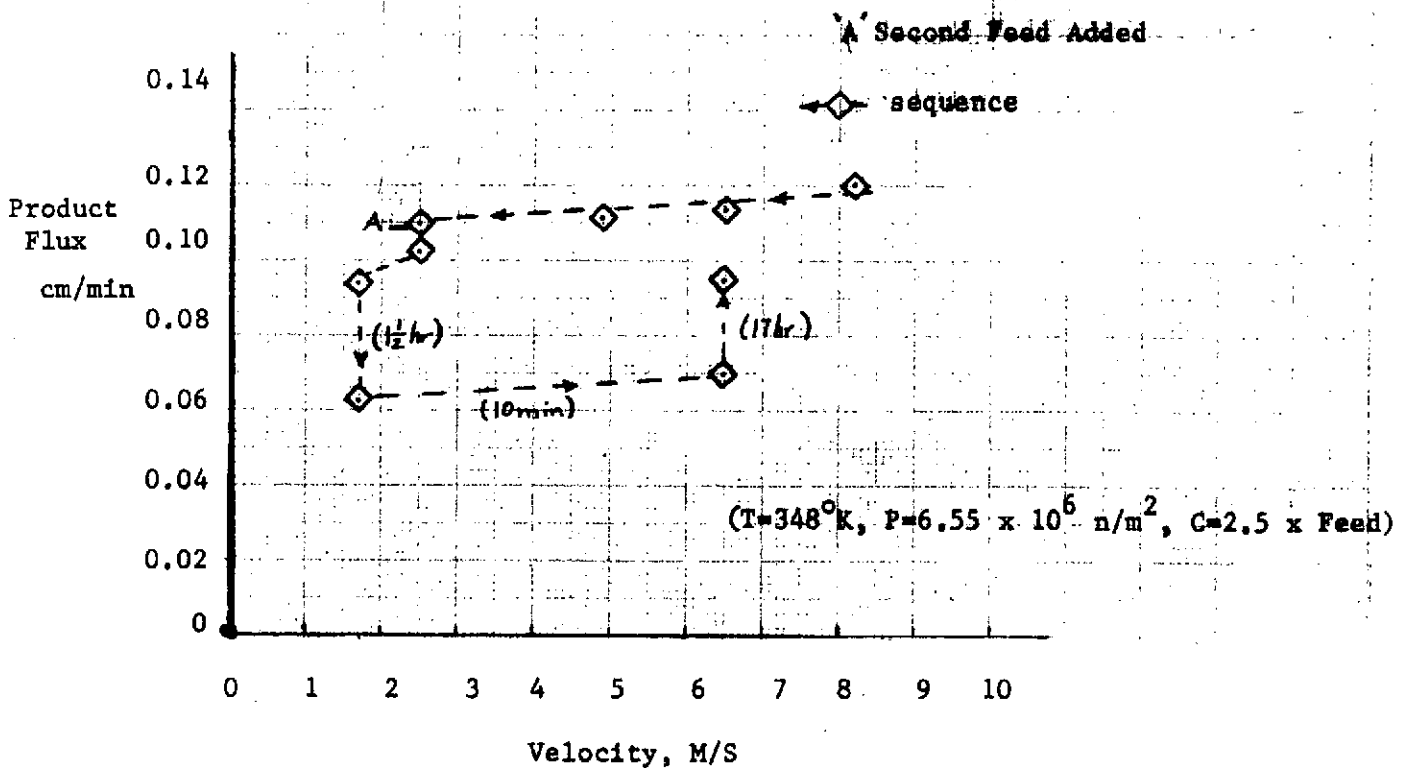
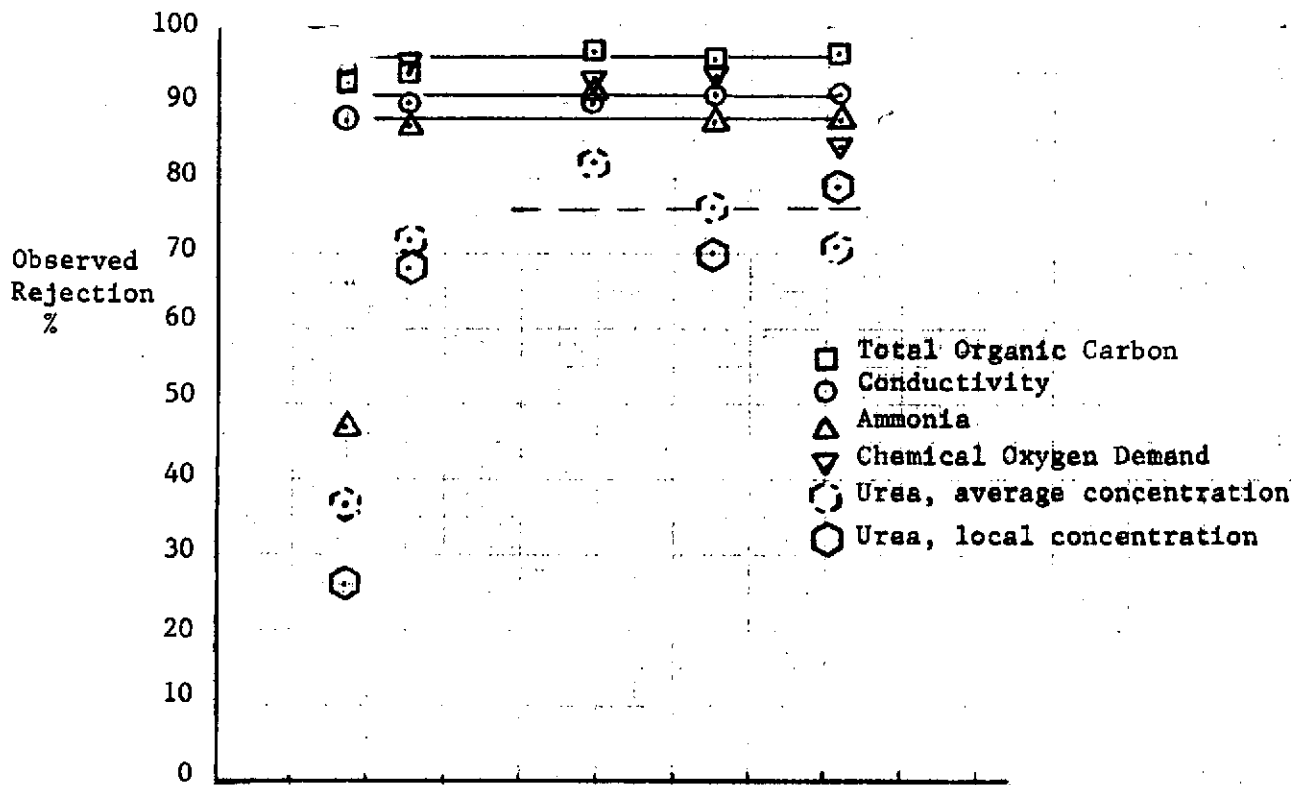

Figure 14 . Performance Variation with Velocity



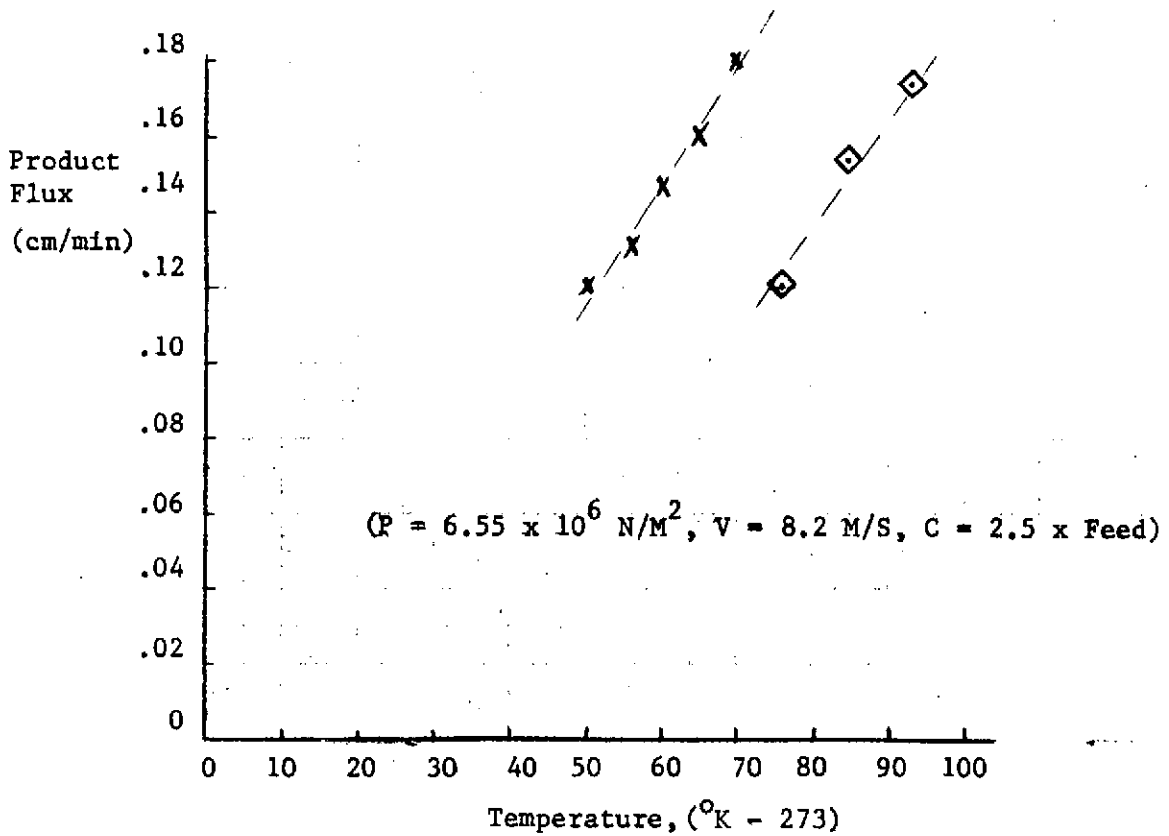
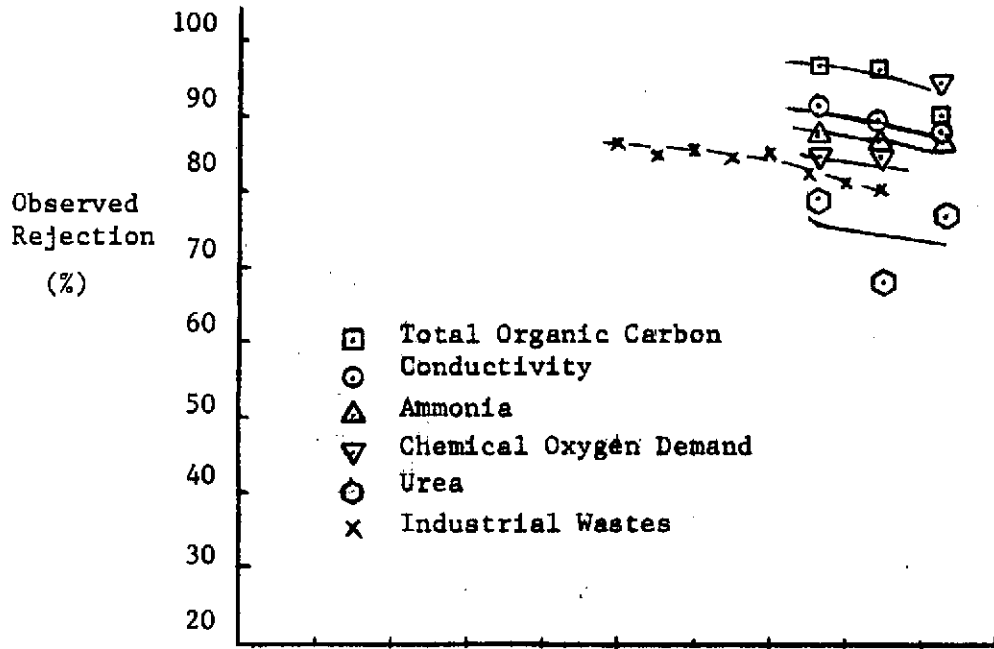

Figure 15. Performance Variation with Temperature

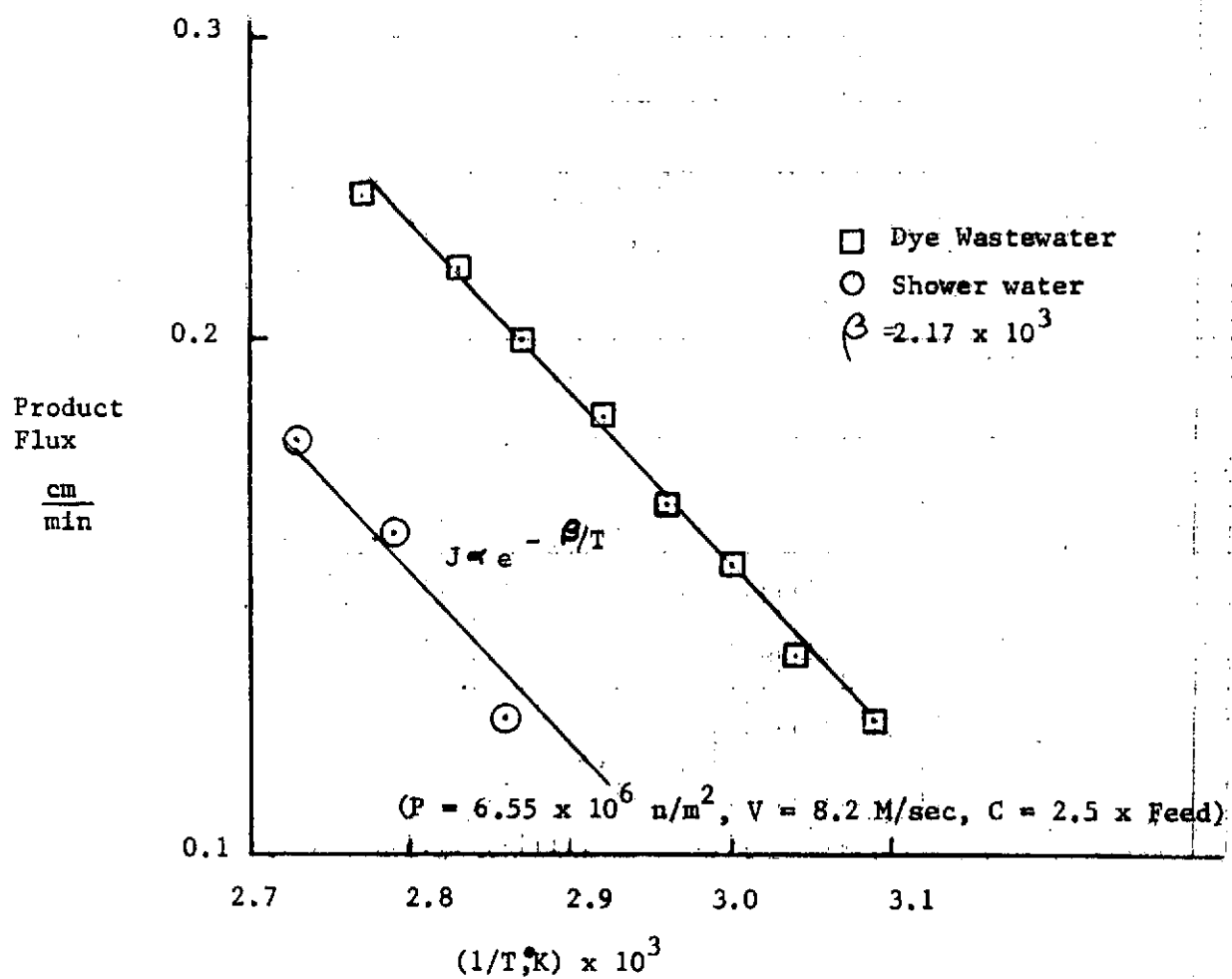

Figure 16 . Variation of Product Flux with Temperature

The outstanding effect of temperature is marked increase of product flux with temperature elevation. This is accompanied, however, by a decrease in rejection of solutes in the shower water.

#### 6.2.4 Concentration

Following a total loss of shower water because of a failure in the pump seal, the concentration scan was carried out during a 116 hour period on July 8 through July 13. While the significance, if any, is not known, it is noted that the membrane was isolated in shower water during the 4 days that the pump repair was effected.

In Figure 17, the variation of the concentration of T.O.C. and ammonia in the product water is shown as the mixed product concentration versus the fraction of feed collected. The variation in the product flow rate is used to determine the concentration of the accumulated mixed product. The end of the test was determined by the minimum system volume for stable pump operation, not by any item related to processing difficulties.

The mixed product concentrations for these important solutes are 37, 6.5, and 50 for T.O.C.,  $\text{NH}_3$ , and urea, respectively. Since  $\text{NH}_3$  must be held to within 1 ppm, additional processing will be required. In one pass of 93 percent recovery, the  $\text{NH}_3$  level was reduced from 24 to 6.5. An additional reprocessing will result in a concentration of  $6.5 \times 6.5/24$  or 1.76. Thus a two stage process will nearly result in acceptable water quality.

In Figure 18, the rejection of the three solutions, T.O.C.,  $\text{NH}_3$ , and urea are shown against the recovery factor, i.e. the concentration factor based on volume of collected product. The flow rate history of this scan during its earliest stages has been discussed and shown in Figure 7. The influence of fresh feed on the membrane is not well understood, but certainly seems significant. Other experiences with industrial wastes have also indicated a period of accommodation between feed and membrane. This accommodation as regards flux and salt rejection has normally proven to be reversible.

The influence of concentration per se on the rejection of solutes was not found to be significant for T.O.C. There seems to be a significant reduction in ammonia rejection for high concentration factors. The general data of the parametric runs had resulted in  $\text{NH}_3$  rejection about 0.88, while the results at high concentration tend toward 0.8.

Urea rejections of perhaps 0.75 were indicated during the parametric data runs, while the low concentration portion indicates a substantially lower value. These low concentration data are not highly accurate as the reconstruction of concentrate level from a mass balance using residual analysis can lead to errors. However, these errors decrease as the higher concentration is approached. The level of urea rejection may well be about 0.70, but an average value of 0.6 is claimed. Either value should result in acceptable separation if multistage filtration is adopted.

### 6.3 Conclusions with Respect to End Item Design

Ammonia concentration appears to be the primary design item, having an expected feed concentration of 20 to 30 ppm and a product target of 1 ppm.

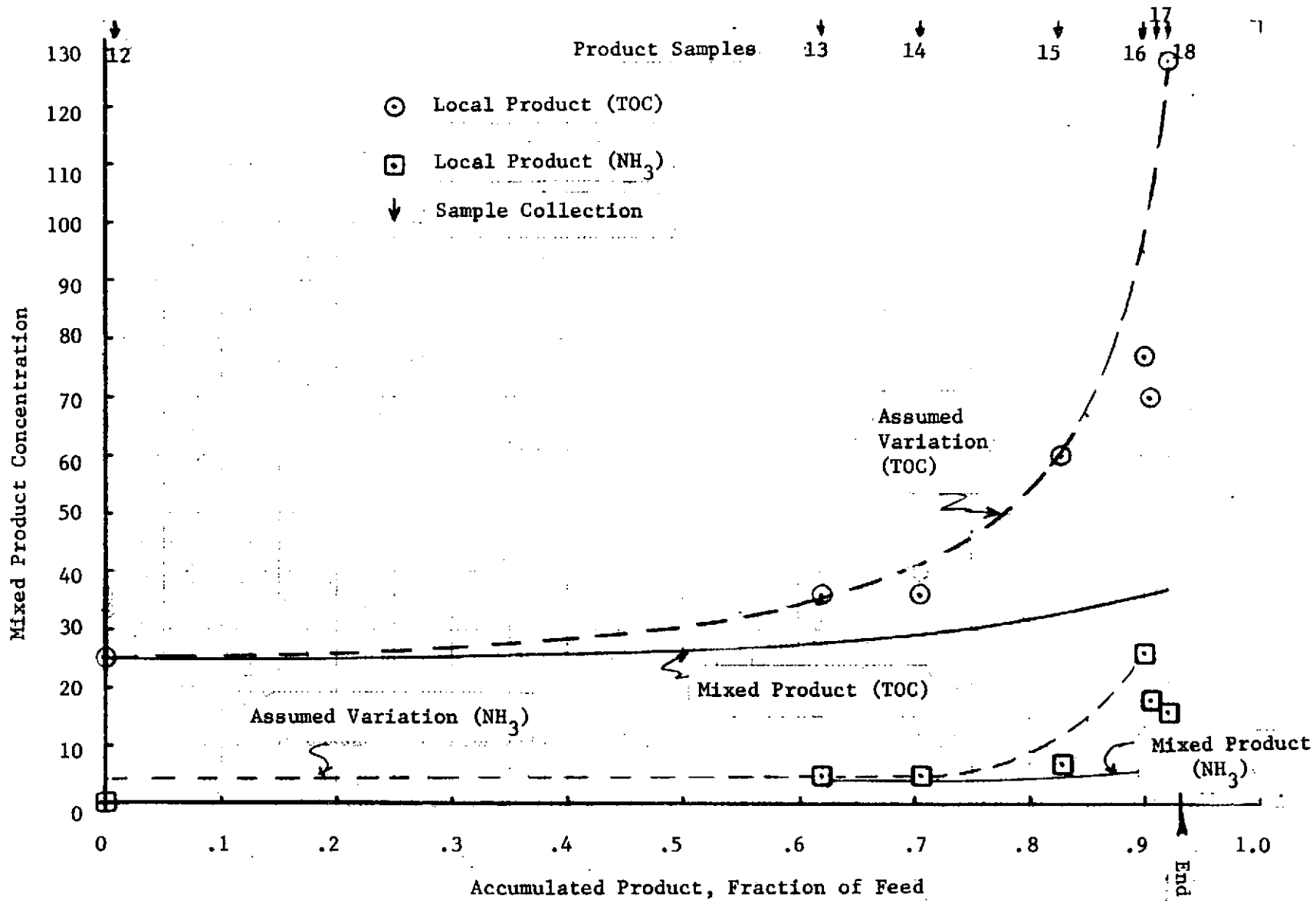

Figure 17 . Calculation of Product Water Quality versus Feed Recovery  
 (P = 6.6 x 10<sup>6</sup> n/m<sup>2</sup>, V = 3to7M/sec, T = 75C)

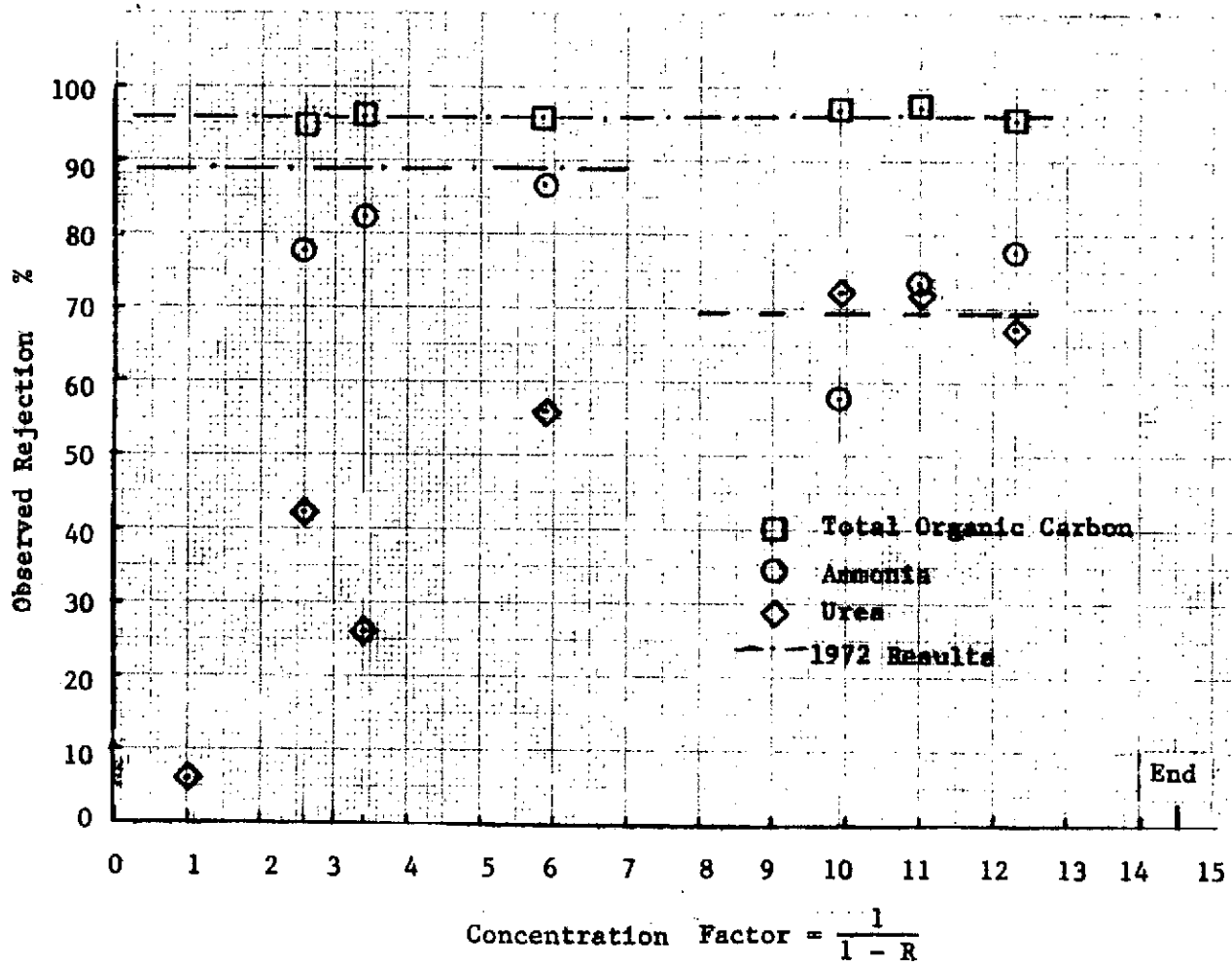

Figure 18 . Observed Rejections During Concentration Scan

While it is possible to consider controlling the breakdown of urea to ammonia, thus reducing the feed concentration, the following assumes direct filtration.

Figure 19 shows the schematic diagram of a system which, according to the data reported herein, will meet the accepted potability requirement. The module is a once-through type design which produces 93 percent product water and 7 percent reject. The product water is tested on line and compared to the allowable value. If the concentration is unacceptably high, the product is mixed with the feed batch, thus lowering its concentration. When the product issues at an acceptable level, it is allowed to pass into the water storage reservoir. The single stage recovery (93 percent) is not constrained; however, its value is a factor in the overall recovery and the required pump flow rates. On the average, almost three feed volumes of fluid must be processed before acceptable product has been completely produced. Each time a feed volume passes, 7 percent is converted to residue. Therefore about 21 percent of the original feed would become residue, or the system recovery would be 79 percent. It is emphasized that this is a workable example which does not represent any attempt to achieve an optimum recovery. When the ammonia content has been reduced to 1 ppm, the organic carbon will be reduced to about 2 ppm, the urea to about 17 ppm, and most other salts reduced to threshold-of-measurement values.

The data obtained herein are for tubular flow in a 2 mm diameter channel. This channel, with a flow rate of 0.00531 l/sec has a velocity of 1.64 m/sec. Assuming this flow is the exit flow of a 93 percent recovery module, the entering flow to the module is .07582 liters per second. At this flow, and a rise of 130 atmospheres in the pump, one calculates the fluid power to be  $1.3 \times 10^7 \text{ N/M}^2 \times 7.58 \times 10^{-5} \text{ M}^3/\text{sec} = 985 \text{ NM/sec} = 985 \text{ watts}$ . This rather substantial power requirement may be decreased through development of a smaller diameter flow channel or operation of the membrane at velocities less than 1.64 m/sec. For example, operation at 1 m/sec in a channel 1.5 mm in diameter would reduce the pump power requirement to 340 watts. On the other hand, an increase in the recovery above 93 percent will increase the pump power.

The average flow produced, per tube, in the test reported herein was about 0.002 liters/minute. To produce .07 lit/sec of fluid requires 2100 tubes of this size. Packed in a close hexagonal array, at spacing of 5 mm, this number of tubes would occupy a cylinder 18.3 cm diameter, 35 cm long. This estimate is both conservative and non-conservative, in that the product flow rates should be higher than estimated and in that achievement of a close-packed hexagonal array represents a development problem.

The power required for such a system will depend strongly upon the low velocity which can be tolerated. The velocity enters strongly into the membrane pressure drop; which, at a 2 M/sec is roughly equal to the pressurization itself. Using expected high efficiency components will allow processing under 20 watt hours per kg (9.1 watt hours/lb).

#### 6.4 Experience with Washwater Preparation

The following table relates the Clemson experience in washwater production. All washwater was produced according to Reference 3.

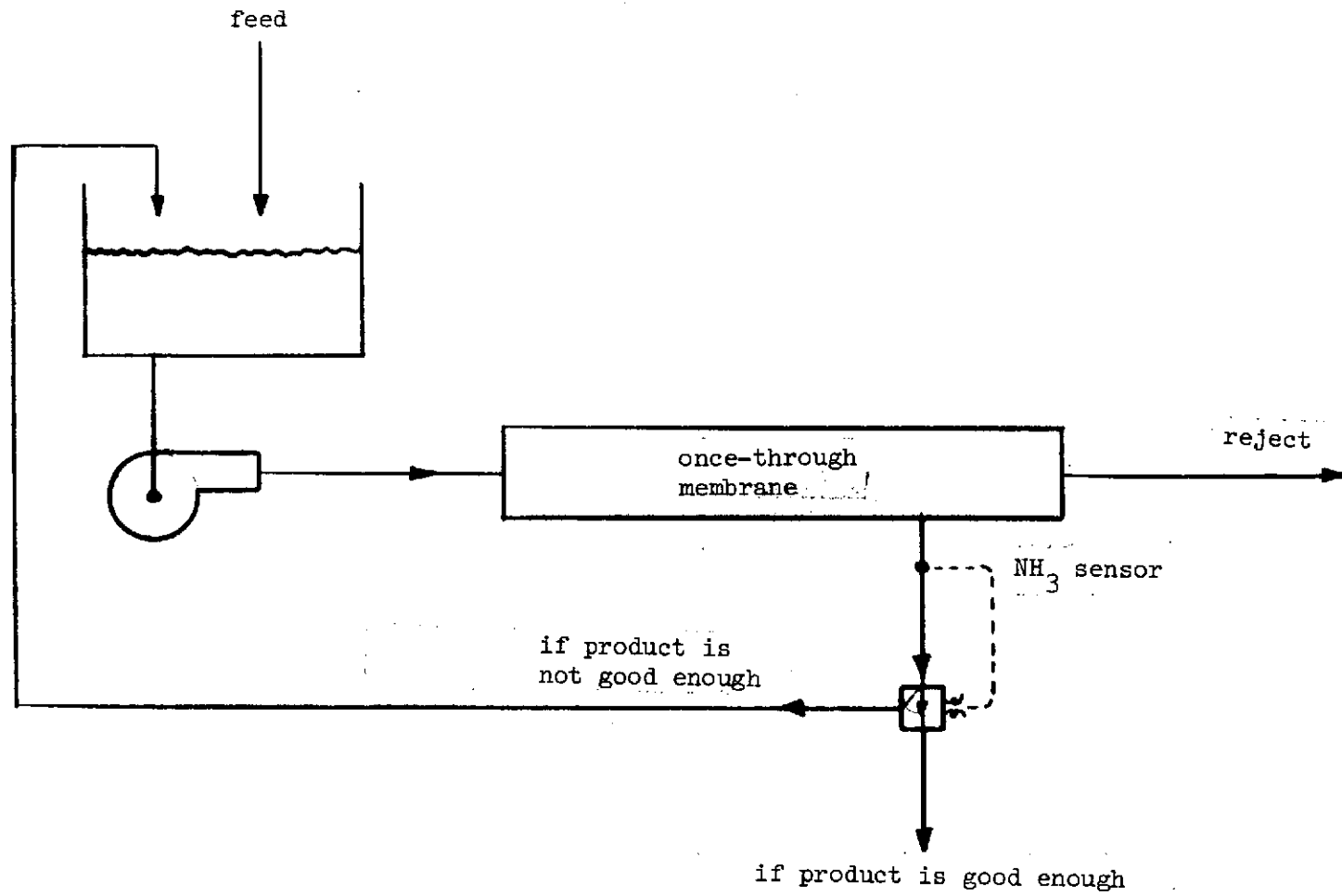

Figure 19 Arrangement of Projected System Used for Estimation

Batch Number	Date Fluid Added	pH	Conductivity (micromhos per cm)	Sample Number	Remarks
1	6-4-75	5.4	670		Poor sample due to lack of soap.
2	7-1-74		530		When generated before adding to pump reservoir.
2	7-1-74	7.4	1000	1F	When added to tank.
3	7-2-74	4.7	660	9F	Before neutralization.
3	7-2-74	7.3	920		After addition of .002 moles NaOH per liter.
4	7-8-74	5.0	535	12F	Before adjustment.
4		6.1	640		After addition of 20 g active ingredient of olive leaf in about 70 liters of washwater.
5	7-9-74	6.3			Before standard washwater supplement addition.
5		4.3			After supplement addition.
5		6.0	650	*13C	After addition of 13 g olive leaf in about 70 liters of washwater.

\*13C is that produced by slightly concentrated batch 4 plus batch 5.

The first washwater produced was deficient in soap content due to reading the prescription as "grams of soap" rather than "grams of active ingredient of soap". The Olive leaf soap is nominally 20 percent active ingredient resulting in about 20 percent of the prescribed soap amount. The acidity of the solution was counter to expectations and was attributed to the lack of soap when the error was discovered. The next batch of shower water was stored in a closed barrel for several days before addition to the test loop. At generation the pH was not recorded but conductivity definitely increased during storage.

The third batch of shower water was checked just before delivery to the feed reservoir and was strongly acid. The reasons were unknown but the relatively strong variation in water was of concern because of the expected effect on membrane rejection, which could and did confuse the effect of the other parameters. After the immediate test conditions were satisfied, the acid condition was changed by adding NaOH. This action was taken considering several factors.



- (1) It was not considered normal for washwater to have pH below 6.
- (2) While some variations are expected the effect of pH on salt conductivity rejection add an unwanted complication.
- (3) For the sake of greater uniformity, neutralization was considered beneficial.
- (4) The ion rejection performance of the dual layer membrane is better at neutral or slightly alkaline feed conditions so that even if the feed were acid, addition of base might occur.
- (5) A survey of shower takers indicated difficulty in using as much as the prescribed soap amounts. Hence the actual soap content (a basic solution) may still have been deficient.
- (6) Later additions of base should be done with soap rather than with NaOH.

The next batch of shower water was carefully noted to be acidic though perhaps half that of the preceding batch. Estimating that perhaps only half of the expected soap had been used by the bathers, an equal amount was added, then doubled to ultimately yield a pH of about 6.1. The pH of the shower additive used to supplement the test subject's secretions is dictated by the lactic acid component. Shower additive and soap alone added in the prescribed proportions produced a solution having low pH (below 5). This leads us to believe that all wash water produced according to the formula would be acid — contrary to expectations for "natural" washwater.

Further observations were made concerning the generation of washwater. The source tapwater is acid in our laboratory and after filtration through a U.O.P. commercial reverse osmosis unit has a pH of about 6.0 though low in conductivity (below 10 micromhos/cm). After showering and laundering of clothes the pH was 6.3. Upon addition of the shower additive the pH was 4.3. About 0.18 g of active olive leaf ingredient per liter of washwater was required to produce pH = 6.

The concern over feed pH centers in the desire for consistent results which, as nearly as possible, represent the intended application. The rejection of NaCl in dynamic membranes is well known to be highly sensitive to pH in the range below pH = 8. In fact, it is not unusual to observe a 10 percentage point rejection decline from pH = 7 to pH = 6. Whether the acidity index has a profound effect on the rejection of other solutes was not, and is not, known. The reported performance variations near low velocity happened to coincide with the insertion of new feed which lowered the pH by a unit. It is strongly suspected that the pH decrease may have had a larger influence than the velocity in producing the lower values of rejection observed. However, because the effects are inseparable in the data acquired, no certain conclusion can be drawn. Further concern exists in that future testing of pH sensitive membranes conducted on the analog shower water may not represent the intended application. The evidence already presented leads to the conclusion that acid washwater will result from application of the standard procedure.

All reports of prototype washwater indicated that its pH should be neutral to slightly basic. These data suggest the review of the analog washwater generation procedure, particularly with respect to the additive solution composition.

## 6.5 Experience with Mechanical Design

Membrane mechanical details are considered to be of secondary interest. However, the following discussion is intended to illuminate the experience obtained during the present effort.

Normally the concentrate flow (pressurized) is separated from the product flow by the membrane on a tubular support. The tube serves to afford the membrane structural support, while exerting a minimum impedance to the product flow. To allow structural support it has been determined by experience that the support must be characterized by a small pore size. On supports having a naturally high (above  $\sim 1\mu\text{m}$ ) pore size, it is necessary to first deposit a filter aid upon which the membrane may be formed. The effect of the type of material comprising the support is not known.

Membranes have been formed on the outside and the inside of tubular supports, with product recovery respectively inside and outside the tube. The outside pressurization clearly make use of the advantage of loading ceramic tubes in compression. However, the uniformity and magnitude of important fluid mechanical properties are less predictable. For example, the shear stress (and hence mass transfer rate) on the central tubes is expected to be less by an undetermined amount than the shear stress computed on an average velocity basis. In the reverse osmosis module, as in heat exchangers, the performance is increased by achieving (or forcing) flow uniformity. Similarly the data in uniform flow are not masked by effects of averaging over a range of velocities.

From the aforementioned motivation it was desired to employ several tubes in a parallel flow arrangement. The Selas ceramic tubes had been found to be relatively strong in tension and had pore properties which allowed the deposition of membranes without the use of filter aids. Two types of arrangements were anticipated. One used eighteen single channel tubes in a parallel flow arrangement, while the other used six tubes, each having seven 2 mm diameter channels, in a similar arrangement. Care was taken that misalignment of the tubes and tube sheets sufficient to load any tube in bending was not possible.

On several different occasions, we ruptured tube supports. No particularly extensive investigations were conducted to determine the cause, except to allow reasonable confidence that the ruptures were not caused or aided by external structural loading. Having eliminated design innovation as an immediate solution to the problem, we employed a single, seven channel tube to perform the testing. The tube was mounted essentially as shown in Figure 3, page 13. In this configuration we burst several tubes, but were able to operate with a reasonably high success ratio.

The conclusion made concerning both multiple tube bundles is that the increase in failure probability with the numerical increase in tubes is high enough to preclude reasonable reliable operation. This conclusion is based on

elementary probability estimates with failure probability nearly proportional to the number of tubes; and on the observed failure rate. Two immediate failures occurred with the eighteen tube module; several failures occurred in spans of zero to several operating hours for the six tube module; and three or four failures occurred during long duration runs in the order of days with the single tube.

#### 7.0 PRETREATED URINE TEST RESULTS

It was desired to determine the performance of the dual layer membrane on pretreated urine. About 20 gallons of electrolytically pretreated urine were added to the system reservoir and processing initiated. The pH of the fluid was raised to ~6.0 by the addition of NaOH. A slight precipitate was noted. A membrane never exposed to waste was retrieved from storage. Its performance was nominally 82 percent at 0.2 cm/min flux.

Table IV shows the results obtained with urine processing. The sample U1F represents the raw feed, U2P is the initial product sample. As the run proceeded with product being collected, a seal leak developed. The outflow of leak and product together resulted in shutdown after having processed only 30 percent of the feed. So 64 liters were added, 19 liters of product were collected, 10 liters of concentrate remained in the system after shut down, and thus 35 liters escaped by the leak. Sample U4P represents the mixture of the last 8.2 liters of product, while U4c was drawn from the system residue.

During the initial part of the test when the rig was attended, the flux underwent the following variations:

Time hr:min	Temp. °C	Flux cc/min	Flux cm/min corrected to 349K
0	328	.153	.228
0:05	335	.174	.209
0:15	342	.175	.184
9:00	347	.100	.0965
13:20	349	.117	.117

The addition of feed here resulted again in reduction of flux by 2/3, followed apparently by a tendency to recover.

The rejection of important quantities are as follows:

	<u>Early in Test</u>	<u>Late in Test</u>
NH <sub>3</sub>	53%	57%
Urea	68%	68%
Conductivity	62%	54%

These data indicate the general tendency of the membrane to exhibit lower rejection at high concentration for solutes which are ion excluded. It is of some interest that for urea and NH<sub>3</sub> the rejections are still reasonably intact at values of concentration an order of magnitude larger than that of the residual concentrate produced from washwater.

Table IV. Urine Test Results

Determination	U1F	U2P	U4C	U4P
Chromium as $\text{Cr}^{+6}$ , ppm				50
Silver as Ag, ppm				
Zinc as Zn, ppm				
Fluoride as F, ppm				.42
Nitrate as $\text{NO}_3$ , ppm	1450		1575	625
Sulfate as $\text{SO}_4^{-2}$ , ppm				
Chloride as $\text{Cl}^-$ , ppm				355
Conductivity (umho/cm)	18,500	7,100	19,000	8,700
TOC, ppm				
COD, ppm				
$\text{NH}_3$ , ppm	800	379	1050	450
Urea, ppm	2250	715	2850	920
pH	6.56	7.14	6.5	6.88
Inorganic Carbon, ppm				

## 8.0 REFERENCES

1. C.A. Brandon and J.C. Hester, "Feasibility Demonstration of High Temperature Hyperfiltration of Shower Water" NASA CR - 112127, Clemson University, 1972.
2. J.S. Johnson et al, "Hyperfiltration", Principles of Desalination, K.S. Spiegler et al editor, Academic Press, N.Y. 1966.
3. D.F. Putnam and G.W. Wells, "Definition of Reverse Osmosis Requirements for Spacecraft Washwater Recycling", McDonnell Douglas Astronautics Report MDC G 3780, November 1972.

## APPENDIX A - Derivation of Mass Balance Relations

It is possible to use a hyperfiltration membrane in any several flow arrangements. Each of these flow arrangements results in a different quality product water. Two single stage steady flow arrangements and a batch processing arrangement are presented together with predictions of their performance. In each of these the recovery  $R$  is the ratio of product produced to feed supplied, and the system rejection is  $(1 - \bar{C}_p/C_f)$ . The value of mixed product concentration ( $\bar{C}_p$ ) is a product water specification, while feed concentration ( $C_f$ ) is characteristic of shower water. The membrane rejection  $(1 - C_p/C_c)$  is the performance at a point measured by the local product concentration  $C_p$  and the local concentrate concentration.

The first arrangement, indicated in Figure 1a, is one in which the pressurized feed flow is contacted with a long narrow membrane channel in which the solute concentration increases as product is withdrawn. The differential equation which governs this situation is:

$$C_c (1 - \gamma) d\dot{m}_c + \dot{m}_c dC_c = 0 \quad (1)$$

$C_c$  = concentrate concentration

$\gamma$  = rejection

$\dot{m}_c$  = mass flow of concentrate

Under assumption of constant rejection  $\gamma$ , integration yields

$$\frac{C_c}{C_f} = \left( \frac{1}{1 - R} \right)^\gamma = \left( \frac{\dot{m}_f}{\dot{m}_c} \right)^\gamma \quad (2)$$

A mass balance of solute in the feed, concentrate, and mixed product streams may be written as

$$\dot{m}_f C_f = \dot{m}_p \bar{C}_p + \dot{m}_c C_c = \dot{m}_f (R \bar{C}_p + (1 - R) C_c) \quad (3)$$

This equation may be solved for  $\bar{C}_p$ , the mixed product concentration as

$$1 - \gamma_s = \frac{\bar{C}_p}{C_f} = \frac{1}{R} \left[ 1 - (1 - R) \right]^{1 - \gamma} \quad (4)$$

Equation (4) is plotted in Figure A1, which indicates the recovery  $R$  which results in a certain level of system rejection with an assumed membrane rejection ( $\gamma$ ).

A second arrangement is depicted in Figure 1b, wherein feed is introduced into a recirculating loop from which product and concentrate flow. The flow rate of rejected concentrate is adjusted to yield the desired recovery. The system is analysed here under the assumption that the product flow is much less than the loop flow. Under this assumption all positions in the membrane are exposed to equal concentration of solute. A simple equation for the mass

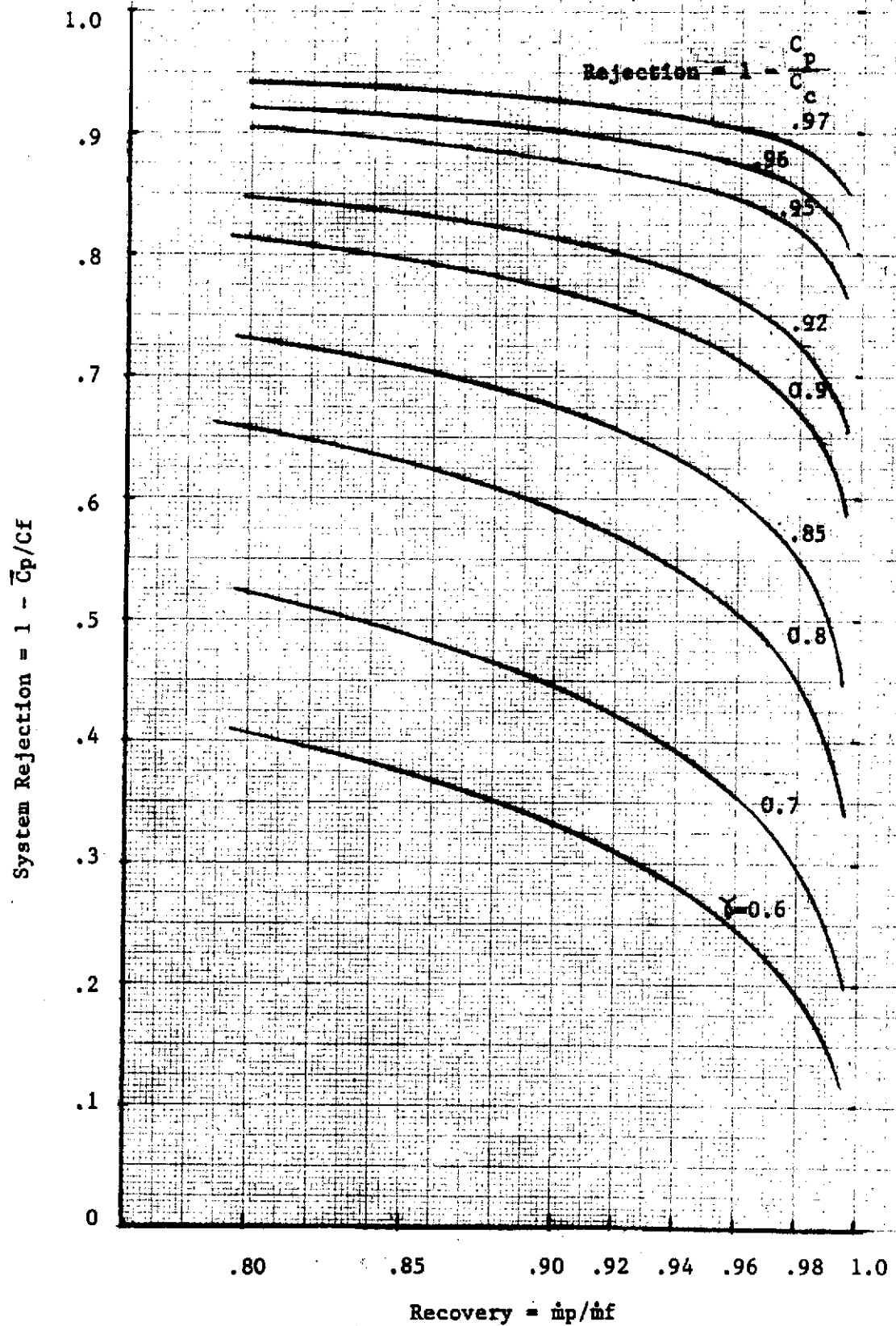

Figure A1 System Rejection vs Recovery for a Once-through Arrangement

balance of solute at steady state is:

$$\dot{m}_f C_f = \dot{m}_p C_p + \dot{m}_r C_c = \dot{m}_f (R C_p + (1 - R) C_c) \quad (5)$$

All product issues at the same quality; hence  $C_p = \bar{C}_p$ . The product quality is related to feed quality through:

$$1 - \gamma_s = \frac{\bar{C}_p}{C_f} = \frac{1 - \gamma R}{1 - R} \quad (6)$$

Equation (6) is plotted in Figure A2 with coordinates identical to those used for the once-through design. It is noted that lesser recoveries are uniformly possible for this arrangement than for the once-through arrangement.

A third arrangement is that a batch process wherein feed is gradually processed to a recovered product and concentrate. The concentrate passing through the membrane is mixed with the feed batch as shown in Figure 1c. The fluid is assumed to pass the membrane essentially without concentration. In time (dt) an amount of product ( $dm_p$ ) is produced having solute mass  $(1 - \gamma)C_c dm_p$ . This flow is accompanied by a equal depletion of solute in the loop which may be expressed as  $d(m_c C_c)$ . Equating these gives

$$C_c dm_c + m_c dC_c = - (1 - \gamma) C_c dm_p.$$

Certainly  $dm_c = dm_p$ , which, substituted into the above and rearranging gives

$$m_c dC_c = \gamma C_c dm_c \quad (7)$$

Integration yields, signifying initial quantities by subscript f,

$$\frac{C_c}{C_f} = \left( \frac{m_f}{m} \right)^\gamma \quad (8)$$

But, the product aggregate  $m_p$  plus  $m$  must be  $m_f$  and  $m_p/m_f$  is the recovered fraction,  $R$ , so

$$\frac{C_c}{C_f} = \left( \frac{1}{1 - R} \right)^\gamma \quad (9)$$

Equation (9) is identical to equation (2) indicating a formal equivalence of the once-through arrangement and the batch process.

The highest recovery simple systems are either the once-through or the batch process. Higher recovery may be achieved in many different two-stage processes, at the expense of complexity and higher power requirements.



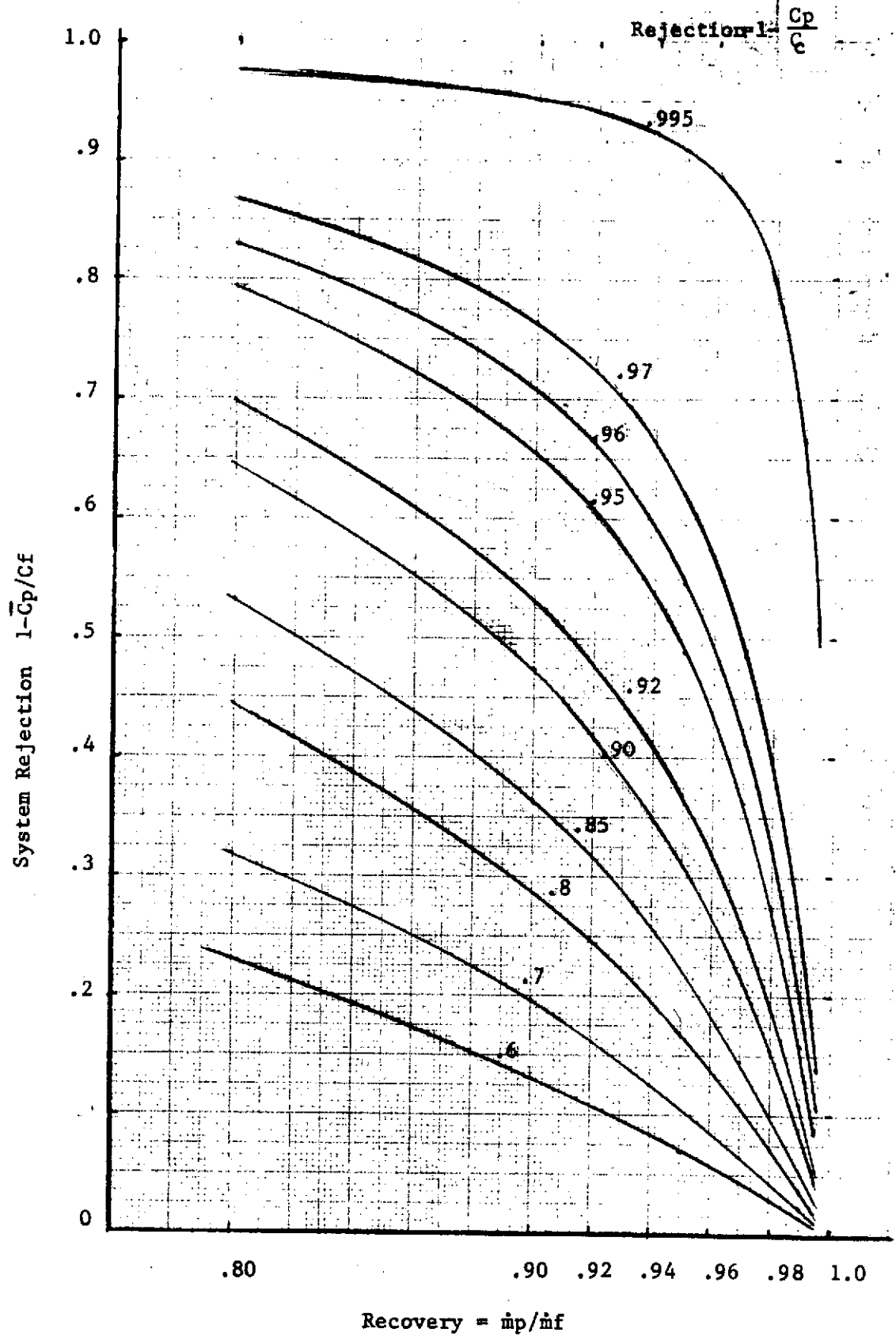

Figure A2 Rejection vs Recovery for a Recirculating Arrangement

APPENDIX B - Test Log Summary

The performance of individual membranes is denoted (X, Y)  
 X = percent rejection    Y = flux in GFD.    Flow of product in cc/min  
 may be multiplied by 2.4 to yield GFD.

<u>DATE</u>	<u>REMARKS</u>
4-20	Pump turned on.
4-22	Loop A-B wash.
4-23	Membrane 1 attempt - bad procedure and iron in system - membrane no good.
4-29	Membrane 2 attempt - poor procedure - good membrane, 94, 42.
5-6	Membrane 2 regenerated and stored 96, 35.
5-7	Membrane 3 formed 89, 69. Regen. of M3 - no improvement.
5-10	6 - 7 hole tube membrane 25%. M4 inspected for leakage.
5-15	Attempt M4 regen. 30% rejection.
5-15	Dismantle; broken tube found.
5-16	Order short center rod.
5-21	Reassemble 6-tube for M5.
5-22	Formation of M5 unsuccessful.
5-23	Order modifications to 6-tube unit.
5-24	ORNL M6 trial unsuccessful.
5-27	A - B wash.
5-28	Single tube M7 94, 39; 89, 64 overnight.
5-29	Regen. M7 to 94, 32 and store M7.
5-30	Six tube module installed for M8. Two successive fractures.
5-31	Two 19-tube outside-in bundles, M9. 88, 130.
6-4	M7 reinstalled and regenerated to 96, 27.

6-5 M7 degrade to 94, 28.

6-5 Add 21 gallons washwater.

6-6 to 6-7 First parametric run.

Parametric run consisted of T = 349<sup>o</sup>K; V = 8 M/sec; P = 65, 58, 51, 70 atmos.  
Followed by T = 358<sup>o</sup>K, 368<sup>o</sup>K, Recheck 350<sup>o</sup>K; V = 8 M/sec; P = 65 atmos.  
Followed by T = 350<sup>o</sup>K, V = 4, 2.8, 1.6 M/sec; P = 65 atmos.

6-8 System refilled with tap water. Discovered soap error.

6-10 Salt added to water. 78%, 55.

6-11 Tried wash (NaCO<sub>3</sub>) and regeneration. 88, 31.

6-12 System washed. Installed 18 tube module.

6-13 Attempted formation. Fractured tubes on two successive trials at 20 atmos.

6-14 Installed 6 tube (7 holes each) module.

6-15 Attempt M8. Tube fracture. Reinstall single 7 hole tube. Attempt M9. 71, 103.

6-17 Stored membrane M2 from 5-6-74 installed. Performance before was 95.6, 38. After 3 hours, performance is R = 95.4 @ 50 cc/min. Shower water added. Broke support within 1 hour.

6-18 Resolved to produce three acceptable membranes before further testing.

6-19 After washing loop attempt M10. 80.5, 129.

6-20 Regenerate M10. 89, 91. store M10.

6-21 Install new water filter: a Gulf replacing the DuPont. Attempt to clean system again. Start M11. R = 92 at 30 cc/min.

6-22 M12 is R = 87 @ 38 cc/min; store M11.

6-22 Start M12. R = 90 @ 12 cc/min.

6-24 Store M12 @ R = 88, 12 cc/min. Start M13. R = 87 @ 23 cc/min. Store M13.

6-25 Start M14. R = 80 @ 51 cc/min. Regenerate M14. R = 81 @ 44 cc/min. M14 not stored. Start M15. Procedure error.

6-25 Start M16. Before PAA addition, lost pressure and shut down.

6-26 Failure discovered to be an "O" ring. Start PAA layer, R = 83 @ 27 cc/min. Regenerate M16, R = 86 @ 19 cc/min. M16 stored.

6-27 Attempt to regenerate M13. M13 stored @ R = 88, 17.5 cc/min.

6-27 & 28 Wash system with Biz, followed by base/acid procedure.

6-28 Start M17, R = 86 @ 54 cc/min.

6-29 M17 is 80 @ 70 cc/min. Black powder noted in water.

6-29 M17 regenerated to R = 91 @ 27 cc/min. Store M17.

7-1 M11 reinstalled. R = 87 @ 42 cc/min.

7-1 Regenerate M11 to R = 96 @ 19 cc/min.

7-1 Add shower water to system and use M11.

7-2 & 3 Perform pressure, temp, and velocity variations.

7-3 Start concentration run.

7-4 Seal has failed on pump.

7-8 Receive seal and install. Start concentration run again.

7-11 Perform pressure survey.

7-12 Perform velocity survey.

7-13 End concentration run.

7-16 After salt water exposure, M11 performance is R = 80% @ 20 cc/min.

7-17 Reinstalled M17. Performance is R = 87 @ 31 cc/min.

7-18 Urine sample pH adjusted to ~6 and added to system.

7-19 After 30 percent recovery of product terminate test due to pump seal leakage.

APPENDIX C - NASA Analytical Methods

The following were employed as analytical equipment utilized by NASA-JSC.

Analysis	Method
pH Fluoride Resistivity Total Solids	Orion Model 801 Digital pH meter/Ionalyzer Barnstead Model PM 50 Water Purity Indicator Mettler Model B6 Analytical Balance
Organic Carbon Inorganic Carbon	Beckman Model 915 Total Organic Carbon Analyzer
Cadmium Copper Iron Lead Magnesium Manganese Mercury Nickel Potassium Silver Sodium Zinc	Jarrell-Ash Atomic Absorption Spectrophotometer Model 82500 series/Varian Carbon Rod Atomizer Model 63
Chromium Ammonia Nitrate Sulfate Chloride	Colorimetric - Beckman ACTA CIII UV-Visible Spectrophotometer