

NASA TECHNICAL NOTE



NASA TN D-7820

NASA TN D-7820

(NASA-TN-D-7820) DIGITAL PROGRAM FOR SOLVING THE LINEAR STOCHASTIC OPTIMAL CONTROL AND ESTIMATION PROBLEM (NASA)	N75-23204
HC \$6.25	Unclas
CSCS 12A	21043
	H1/63

DIGITAL PROGRAM FOR SOLVING THE LINEAR STOCHASTIC OPTIMAL CONTROL AND ESTIMATION PROBLEM

Lucille C. Geysler and Bruce Lehtinen
Lewis Research Center
Cleveland, Ohio 44135

REPRODUCED BY
NATIONAL TECHNICAL
INFORMATION SERVICE
U. S. DEPARTMENT OF COMMERCE
SPRINGFIELD, VA. 22161

NOTICE

THIS DOCUMENT HAS BEEN REPRODUCED FROM THE BEST COPY FURNISHED US BY THE SPONSORING AGENCY. ALTHOUGH IT IS RECOGNIZED THAT CERTAIN PORTIONS ARE ILLEGIBLE, IT IS BEING RELEASED IN THE INTEREST OF MAKING AVAILABLE AS MUCH INFORMATION AS POSSIBLE.

1. Report No. NASA TN D-7820	2. Government Accession No.	3. Recipient's Catalog No.
4. Title and Subtitle DIGITAL PROGRAM FOR SOLVING THE LINEAR STOCHASTIC OPTIMAL CONTROL AND ESTIMATION PROBLEM		5. Report Date March 1975
		6. Performing Organization Code
7. Author(s) Lucille C. Geysler and Bruce Lehtinen		8. Performing Organization Report No. E-8016
		10. Work Unit No. 501-24
9. Performing Organization Name and Address Lewis Research Center National Aeronautics and Space Administration Cleveland, Ohio 44135		11. Contract or Grant No.
		13. Type of Report and Period Covered Technical Note
12. Sponsoring Agency Name and Address National Aeronautics and Space Administration Washington, D. C. 20546		14. Sponsoring Agency Code
15. Supplementary Notes		
16. Abstract <p>This report describes a computer program, LSOCE, which solves the linear stochastic optimal control and estimation (LSOCE) problem by using a time-domain formulation. The LSOCE problem is defined as that of designing controls for a linear time-invariant system which is disturbed by white noise in such a way as to minimize a performance index which is quadratic in state and control variables. The LSOCE problem and solution are outlined; brief descriptions are given of the solution algorithms; and complete descriptions of each subroutine, including usage information and digital listings, are provided. A test case is included, as well as information on the IBM 7090-7094 DCS time and storage requirements.</p>		
17. Key Words (Suggested by Author(s)) Application of mathematics; Control systems; Control theory; Covariance; Eigenvalues; Eigenvectors; Kalman filters; Linear systems; Lyapunov equation; Modern control; Optimization; Optimal control; Riccati equation; Stochastic processes		18. Distribution Statement Unclassified - unlimited STAR Category 63 (rev.)
19. Security Classif. (of this report) Unclassified	20. Security Classif. (of this page) Unclassified	

CONTENTS

	Page
<u>SUMMARY</u>	1
<u>INTRODUCTION</u>	1
<u>THEORETICAL BACKGROUND</u>	3
FINITE-TIME LSOCE PROBLEM	3
INFINITE-TIME LSOCE PROBLEM	6
MEAN-SQUARE BEHAVIOR	7
LSOCE PROBLEM OPTIONS	8
<u>LSOCE PROGRAM</u>	9
DESCRIPTION AND LISTING OF MAIN ROUTINE LSOCE	10
Option 1 - Infinite-Time Kalman Filter	13
Option 2 - Finite-Time Kalman Filter	14
Option 3 - Finite-Time LSOCE Problem without Mean-Square Information	16
Option 4 - Finite-Time LSOCE Problem with Mean-Square Information	18
Option 5 - Infinite-Time LSOCE Problem	22
Option 6 - Infinite-Time, Noise-Free Regulator	24
Option 7 - Finite-Time, Noise-Free Regulator	26
Option 8 - Infinite-Time Regulator with Plant Noise	27
Option 9 - Open-Loop, Plant-Covariance Matrices	29
Listing of Main Routine LSOCE	31
DESCRIPTIONS AND LISTINGS OF SUBROUTINES	33
Description of Subroutine ESTMAT	33
Listing of Subroutine ESTMAT	35
Description of Subroutine CONTRL	37
Listing of Subroutine CONTRL	40
Description of Subroutine RICSS	41
Listing of Subroutine RICSS	44
Description of Subroutine CONDI	45
Listing of Subroutine CONDI	46
Description of Subroutine REDU	47
Listing of Subroutine REDU	50
Description of Subroutine SCALE	54
Listing of Subroutine SCALE	54
Description of Subroutine EIGQR	55
Listing of Subroutine EIGQR	56
Description of Subroutine ORDER	60

Listing of Subroutine ORDER	61
Description of Subroutine EGVCTR	62
Listing of Subroutine EGVCTR	66
Description of Subroutine PRMUTE	71
Listing of Subroutine PRMUTE	72
Description of Subroutine COVM	73
Listing of Subroutine COVM	74
Description of Subroutine LYPNV	77
Listing of Subroutine LYPNV	78
Description of Subroutine TRICCS	79
Listing of Subroutine TRICCS	83
Description of Subroutine BDSTM	86
Listing of Subroutine BDSTM	89
LSCOCE PROGRAM ERROR MESSAGES	89
<u>CONCLUDING REMARKS</u>	90
<u>APPENDIXES</u>	
A - <u>SYMBOLS</u>	91
B - <u>SAMPLE PROBLEM</u>	95
C - <u>TIME AND STORAGE REQUIREMENTS</u>	159
<u>REFERENCES</u>	160

DIGITAL PROGRAM FOR SOLVING THE LINEAR STOCHASTIC OPTIMAL CONTROL AND ESTIMATION PROBLEM

by Lucille C. Geysler and Bruce Lehtinen

Lewis Research Center

SUMMARY

This report describes a computer program, LSOCE, which solves the linear stochastic optimal control and estimation (LSOCE) problem. The LSOCE problem is defined as that of designing controls for a linear time-invariant system which is disturbed by white noise in such a way as to minimize a performance index which is quadratic in state and control variables. In order to do so, the controls must use system measurements which are corrupted by white noise.

The LSOCE problem and solution are outlined; brief descriptions are given of the solution algorithms; and complete descriptions of each subroutine, including usage information and digital listings, are provided. The major subroutine solves the algebraic matrix Riccati equation by using an eigenvector method. Other major subroutines provided are a Lyapunov equation subroutine, an eigenvalue subroutine, an eigenvector subroutine, and a subroutine for solving the matrix Riccati differential equation. Program LSOCE is designed so that the user has options to solve all or part of the LSOCE problem. A test case for LSOCE (for the option which uses all parts of the program) is included, as well as information on the IBM 7090-7094 DCS time and storage requirements.

INTRODUCTION

Over the past few years, there have been great interest and activity in the area of computer-aided design of control systems. This report documents a computer program which has been used at the Lewis Research Center for designing optimal controls for linear systems that are subject to random disturbances and that have measurements corrupted by noise. This program has been applied in designing control systems for supersonic inlets (refs. 1 and 2). It solves the linear stochastic optimal control and

estimation (LSOCE) problem. The LSOCE problem is defined as that of designing controls for a linear time-invariant system which is disturbed by white noise in such a way as to minimize a quadratic performance index. In order to do so, the controls must use system measurements which are corrupted by white noise. The FORTRAN subroutines described in this report either are modifications of or improvements on subroutines available at present, or are implementations of published algorithms which are not now available as computer programs.

The linear stochastic optimal control and estimation problem is presented in Bryson and Ho (ref. 3) and is summarized in this report (see the section THEORETICAL BACKGROUND). The solution to the LSOCE problem is a Kalman filter, which estimates the system states, coupled through a set of optimal regulator gains to produce the desired control signal. The key to solving the LSOCE problem is the solution of the matrix Riccati differential equation. This equation occurs in solving for both the finite-time optimal linear regulator gains and the finite-time optimal linear estimator (Kalman filter) gains. An important special case is the infinite-time LSOCE problem, in which the main equations to be solved use algebraic (steady state) matrix Riccati equations.

Techniques for solving the Riccati differential equation include direct numerical integration, Kalman and Englar's Automatic Synthesis Program (ASP) described in reference 4, the GASP program of Freested, Webber, and Bass (ref. 5), and Vaughan's negative exponential method (ref. 6). Attention has also been given to solving the algebraic Riccati equation, most notably by Kleinman (ref. 7), Greenberg and Bard (ref. 8), and Fath (ref. 9). The approach taken in this report for solving both the differential and algebraic equations is a combination of Fath's and Vaughan's methods, both of which are extensions of the so-called eigenvector method first discussed by MacFarlane (ref. 10), O'Donnell (ref. 11), and Potter (ref. 12). In practice, the solution of the algebraic equation is used in obtaining the solution to the differential equation.

For the infinite-time LSOCE problem, it is of interest to compute system-covariance matrices so as to evaluate system mean-square behavior. This computation requires solution of a Lyapunov matrix equation. Mean-square behavior can be computed for the finite-time LSOCE problem; however, because of computer storage limitations, it was decided to include only computations for the infinite-time case. Solutions to the Lyapunov equation have been developed by such authors as Chen and Shieh (ref. 13) and Smith (ref. 14). The technique adopted in this program is that of Chen and Shieh, which requires the solution of a set of linear equations.

Program LSOCE was written so as to handle systems of any order and is restricted only by computer storage size and accuracy. In particular, maximum dimensions for system state, control, disturbance, and measurement vectors were selected to be 12, 5, 5, and 5, respectively. These dimensions were chosen so that the program would fit on an IBM 7090-7094 computer (32000₁₀ storage locations) without overlay. These dimen-

sions can, of course, be changed if the user should want to run larger problems, provided that the computer being used has sufficient storage. It should be noted that solution accuracy will be a direct function of system state dimension and also computer word length.

The report is organized as follows: First, the theoretical background for program LSOCE is presented. Then a general description of program LSOCE is given, including a flow chart of the subroutines used; followed by the inputs, outputs, and options; and then individual descriptions of each subroutine, including FORTRAN listings. Appendix A lists the symbols used. Appendix B gives descriptions and listings for a sample problem. Appendix C tabulates the time and storage requirements for the sample problem.

THEORETICAL BACKGROUND

First, the formulation of and solution to the finite-time linear stochastic optimal control and estimation (LSOCE) problem is presented. The formulation used follows that of Bryson and Ho (ref. 3, p. 414). The infinite-time LSOCE problem is then defined, the calculation of mean-square values is described, and various options which the LSOCE program provides to the user are detailed.

FINITE -TIME LSOCE PROBLEM

The finite-time LSOCE problem is defined here as follows: Given the linear time-invariant system

$$\dot{x}(t) = Ax(t) + Bu(t) + w(t) \quad (1)$$

$$z(t) = Hx(t) + v(t) \quad (2)$$

where

x an n-dimensional state vector

u a c-dimensional control vector

z an m-dimensional measurement vector

w an n-dimensional, white, zero-mean, Gaussian, plant-noise vector

v an m-dimensional, white, zero-mean, Gaussian, measurement-noise vector

A an n-by-n system matrix

B an n-by-c control input matrix

H an m-by-n measurement matrix

(All symbols are defined in appendix A.) Noises w and v are assumed to be uncorrelated with each other and to have covariance matrices given by

$$E[w(t)w^T(t + \tau)] = Q\delta(\tau) \quad (3)$$

$$E[v(t)v^T(t + \tau)] = R\delta(\tau) \quad (4)$$

where Q is a symmetric, positive-semidefinite, plant-noise, power spectral density matrix and R is a symmetric, positive-definite, measurement-noise, power spectral density matrix. Further, it is assumed that all matrices are constant and known, that the pair (A, B) is controllable, and that the pair (A, H) is observable. Also, the initial state is assumed to be a zero-mean random variable with a known covariance,

$$E[x(t_0)x^T(t_0)] = P_0 \quad (5)$$

Given a set of measurements $z(\tau)$ for $t_0 \leq \tau \leq t$, find a control u as a functional of $z(\tau)$ which minimizes the quadratic performance index

$$J = E \left[\frac{1}{2} x^T(t_f) S_f x(t_f) + \frac{1}{2} \int_{t_0}^{t_f} (x^T Q_c \dot{x} + 2x^T N u + u^T P_c u) dt \right] \quad (6)$$

Weighting matrix P_c is positive-definite and matrices Q_c and N are such that $(Q_c - NP_c^{-1}N^T)$ is positive-semidefinite.

It has been found that a large number of practical control problems can be formulated in the manner just described. The solution to this problem is well known (see ref. 3 for a derivation of a somewhat more general case). The control which minimizes J is given by

$$u(t) = -K_c(t)\hat{x}(t) \quad (7)$$

where $\hat{x}(t)$ is the optimal estimate of $x(t)$. Estimate $\hat{x}(t)$ is a dynamic function of measurement vector $z(t)$ and is generated as the output of a Kalman filter, described by

$$\dot{\hat{x}}(t) = A\hat{x}(t) + Bu(t) + K_e(t)[z(t) - H\hat{x}(t)] \quad (8)$$

The optimal control-gain matrix $K_c(t)$ is given by

$$K_c(t) = P_c^{-1} \left(B^T S(t) + N^T \right) \quad (9)$$

where $S(t)$ is the (positive-definite, symmetric) solution to the Riccati differential equation

$$\begin{aligned} -\dot{S}(t) = & S(t) \left(A - BP_c^{-1}N^T \right) + \left(A - BP_c^{-1}N^T \right)^T S(t) \\ & - S(t) \left(BP_c^{-1}B^T \right) S(t) + \left(Q_c - NP_c^{-1}N^T \right) \end{aligned} \quad (10)$$

with the boundary condition $S(t_f) = S_f$. The Kalman-filter-gain matrix $K_e(t)$ is given by

$$K_e(t) = P(t)H^T R^{-1} \quad (11)$$

where $P(t)$ is the covariance of $x - \hat{x}$, the error in the estimate, and is found as the (positive-definite, symmetric) solution to the Riccati differential equation

$$\dot{P}(t) = AP(t) + P(t)A^T - P(t)H^T R^{-1}HP(t) + Q \quad (12)$$

with the initial condition $P(t_0) = P_0$.

The combination of the plant, Kalman filter, and state-estimate feedback gains is shown in figure 1. The filter can be viewed as a model of the plant which has been modified by insertion of a signal proportional to the difference between the measurement z and the estimated measurement \hat{z} . This difference is multiplied by Kalman filter gains K_e and inserted into the plant model at the input to the integrators. The optimal control u is formed by multiplying the filter output \hat{x} by control gains K_c .

The finite-time control gains $K_c(t)$ are computed off-line by first solving equation (10) backwards in time from $t = t_f$ to $t = t_0$, starting with $S(t_f) = S(f)$ to obtain $S(t)$. Then $K_c(t)$ values are computed by using equation (9). Similarly, finite-time filter gains are computed off-line by solving equation (12) forwards in time from $t = t_0$ to $t = t_f$, starting with $P(t_0) = P_0$ to obtain $P(t)$. Then $K_e(t)$ values are computed by using equation (11).

INFINITE-TIME LSOCE PROBLEM

A case of particular interest is the solution to the infinite-time LSOCE problem. In this case, gains K_c and K_e are constant, resulting in a control which is much simpler to implement than the finite-time solution. If the final time t_f is allowed to be infinite, the solution to the Riccati equation (10) (and hence the control gains eq. (9)) settles out and becomes constant throughout the period $t_0 \leq t \ll t_f = \infty$. This constant value can be computed by solving an algebraic Riccati equation

$$S \left(A - BP_c^{-1}N^T \right) + \left(A - BP_c^{-1}N^T \right)^T S - S \left(BP_c^{-1}B^T \right) S + \left(Q_c - NP_c^{-1}N^T \right) = 0 \quad (13)$$

which is obtained from equation (10) by letting $\dot{S} = 0$. Similarly, the constant-Kalman-filter-gain solution results if the final time is infinite, where the behavior of the filter in the region near $t = t_0$ is not of major interest. The solution to the Riccati equation (12) will settle out to a constant value for $t_0 \ll t \leq t_f$. This constant value can be computed by solving an algebraic Riccati equation

$$AP + PA^T - P(H^T R^{-1}H)P + Q = 0 \quad (14)$$

which is obtained from equation (12) by setting $\dot{P} = 0$. Thus, the infinite-time (control and filter) solution is the exact solution for the time period of interest, $t_0 \ll t \ll t_f = \infty$.

Performance index J of equation (6) can be examined now where $t_f \rightarrow \infty$. By interchanging the integration and expected-value operations, J can be written

$$J = \frac{1}{2} E \left[x^T(t_f) S_f x(t_f) \right] + \frac{1}{2} \int_{t_0}^{t_f} E \left[x^T Q_c x + 2x^T Nu + u^T P_c u \right] dt \quad (15)$$

The integrand becomes constant as $t \rightarrow t_f$ for large t_f . As $t_f \rightarrow \infty$, it can be seen that the major contribution to J will come from integrating this constant value. Thus, to minimize J , the integrand must be minimized. This leads us to define a new performance index

$$J^* = E \left[x^T Q_c x + 2x^T Nu + u^T P_c u \right] \quad (16)$$

which will be minimized by a control system with constant K_c and K_e matrices. Thus, in summary, the infinite-time problem can be formulated as follows: Obtain a control u

to minimize J^* of equation (16), given a system described by equations (1) to (4). The solution is obtained by solving equations (9), (11), (13), and (14).

MEAN-SQUARE BEHAVIOR

For the infinite-time case, it is of interest to compute various system-covariance matrices and mean-square values by which to judge the control system's effectiveness. Of primary interest is the state-covariance matrix and the covariance of the error in the estimate. The latter is given by the Riccati equation (14). The state-covariance matrix can be obtained by solving the following Lyapunov equation (ref. 3, p. 417):

$$(A - BK_c)X + X(A - BK_c)^T + BK_c P + PK_c^T B^T + Q = 0 \quad (17)$$

where X is the covariance of x . Also, the covariance of estimate \hat{x} can be shown to be

$$\hat{X} = X - P \quad (18)$$

By using \hat{X} , X , and P , the following covariances can be computed: The control covariance is

$$U = K_c \hat{X} K_c^T \quad (19)$$

where u is given by equation (7). The measurement covariance is

$$Z = HXH^T \quad (20)$$

where z is given by equation (2). The estimated measurement covariance is

$$\hat{Z} = H\hat{X}H^T \quad (21)$$

where \hat{z} is the estimated measurement vector given as

$$\hat{z} = H\hat{x} \quad (22)$$

Or, for any general output vector y given as

$$y = Cx \quad (23)$$

one can compute the output covariance

$$Y = CXC^T \quad (24)$$

or the estimated output covariance

$$\hat{Y} = C\hat{X}C^T \quad (25)$$

where \hat{y} is the estimated output given as

$$\hat{y} = C\hat{x} \quad (26)$$

LSOCE PROBLEM OPTIONS

In addition to handling the general finite-time LSOCE solution, the infinite-time solution, and covariance matrix computation, program LSOCE provides the user with a number of options. These options make it possible to solve various subproblems by using portions of the LSOCE program. The subproblem options chosen do not exhaust all possibilities but rather represent the more common variations of the LSOCE problem.

The options available are

(1) Infinite-time Kalman filter: Here, it is desired to estimate (but not to control) the state of the system of equations (1) to (4) for $t_0 \ll t \leq t_f = \infty$. Thus, an infinite-time matrix K_e and constant-error covariance matrix P are to be computed, thereby defining a Kalman filter.

(2) Finite-time Kalman filter: This option is the same as option 1 except that now $K_e(t)$ and $P(t)$ are to be computed given $P(t_0)$ and t_f for $t_0 \leq t \leq t_f$.

(3) Finite-time LSOCE problem without mean-square information: This is the problem defined previously (in the section FINITE-TIME LSOCE PROBLEM), where K_e and K_c are time varying for $t_0 \leq t \leq t_f$.

(4) Finite-time LSOCE problem with mean-square information: This is the problem mentioned in option 3 except that it now includes a calculation of the mean-square behavior (outlined in the section MEAN-SQUARE BEHAVIOR). This mean-square calculation is useful in the case where t_f is large enough so that K_e and K_c are constant during some time $t_0 \ll t_1 \leq t \leq t_2 \ll t_f = \infty$. During the interval $t_1 \leq t \leq t_2$, the system-covariance matrices will be constant. The covariance matrices computed in this option are those which apply within this interval.

(5) Infinite-time LSOCE problem: This is the problem outlined in the section INFINITE-TIME LSOCE PROBLEM, but including the computation of covariance matrices, as in the section MEAN-SQUARE BEHAVIOR.

(6) Infinite-time, noise-free regulator: Here it is assumed that state x is directly measurable and that the system is described by equation (1), but with no plant noise ($Q \equiv 0$). Thus, $x = \hat{x}$, no Kalman filter is required, and the feedback law (eq. (7)) is $u = -K_c x$. The performance index is that of equation (16), and the equations to be solved are (9) and (13) for the Riccati solution and control gains.

(7) Finite-time, noise-free regulator: It is assumed that state x is directly measurable (no Kalman filter needed) and that the system is described by equation (1), but with no plant noise ($Q \equiv 0$). The performance index of equation (6) is to be minimized, given t_f and S_f . The equations to be solved are (9) and (10) for $K_c(t)$ and $S(t)$.

(8) Infinite-time regulator with plant noise: This option is similar to option 6 in that x is assumed to be measurable, but now plant noise is assumed to be present ($Q \neq 0$). The computations required are those of equations (9) and (13). Mean-square information is also provided by solving equations (17), (19), and (24) for covariances X , U , and Y . Note that X will equal \hat{X} , since P will be zero (perfect state measurement); thus, $U = K_c X K_c^T$.

(9) Open-loop, plant-covariance matrices: It may be of interest simply to calculate the covariance matrices for an uncontrolled system disturbed by noise w (with $Q \neq 0$), described by equation (1), having an output $y = Cx$ (eq. (23)). This would be done, for example, in comparing open-loop and closed-loop system behavior. In particular, useful information computed in this option is state covariance X and output covariance Y .

The use of these options in program LSOCE is explained in more detail in the section DESCRIPTION AND LISTING OF MAIN ROUTINE LSOCE. There, the required inputs and available outputs are listed, and the format for system matrices (A , B , H , etc.) to be input is discussed.

LSOCE PROGRAM

This section serves as a user's guide to program LSOCE. It contains first a description of the main routine, followed by sections discussing, in specific terms, the options available in LSOCE, followed by a listing of main routine LSOCE. Then each subroutine is explained and listed, with the exception of subroutines ARRAY, HSBG, MINV, FACTR, and SIMQ, which are IBM Scientific Subroutine Package (SSP) subroutines and consequently are not listed. (The subroutines ARRAY, HSBG, and MINV are defined in the section Description of Subroutine RICSS, subroutine FACTR in the section Description of Subroutine EGVCTR, and subroutine SIMQ in the section Description of

Subroutine LYPNV.) Background information on the methods used is included when necessary. Finally, there is a discussion of error messages.

All symbols are defined in appendix A. A sample problem (using the option which exercises all parts of the program) is given in appendix B. Time and storage requirements for this sample problem are tabulated in appendix C.

DESCRIPTION AND LISTING OF MAIN ROUTINE LSOCE

The computer program which solves the linear stochastic optimal control and estimation problem consists of a main routine, LSOCE, which calls a set of subroutines. The flow chart of this program (fig. 2) shows the calling sequence and gives a brief description of each subroutine. The main routine LSOCE defines the dimensions of the variables and contains the input data for the LSOCE problem. Main routine LSOCE may call the subroutines ESTMAT, CONTRL, COVM, and TRICCS, depending upon which option the user specifies.

The dimensioned variables are

A(N, N)	Lyapunov equation matrix
AA(N, N)	system matrix
AAA(N2, N2)	Hamiltonian matrix associated with the Riccati equation
ANS(N, N)	transient Riccati solution
BB(N, C)	control input matrix
CC(R, N)	output matrix
CI(N2)	imaginary parts of eigenvalues of AAA
CR(N2)	real parts of eigenvalues of AAA
HH(M, N)	measurement matrix
IOR(N2)	block-diagonalizing permutation vector (integer)
KC(C, N)	control-gain matrix
KE(N, M)	estimator-gain matrix
NBL(N2)	size of individual irreducible blocks (integer)
NN(N, C)	state-control product weighting matrix
PCINV(C, C)	inverse of control weighting matrix
PP(N, N)	estimation-error-covariance matrix
PPINIT(N, N)	initial condition of transient Riccati solution for estimate

Q(N, N)	Lyapunov equation matrix
QC(N, N)	state weighting matrix
QQ(N, N)	power spectral density matrix of plant disturbance
RRINV(M, M)	inverse of power spectral density matrix of measurement noise
SS(N, N)	matrix Riccati solution for control problem
SSINIT(N, N)	initial condition of transient Riccati solution for control
TS(N2)	scaling transformation vector
UU(C, C)	control-covariance matrix
X(N2, N2)	modified eigenvector matrix of AAA
XX(N, N)	state-covariance matrix
YY(R, R)	output-covariance matrix
YYEST(R, R)	estimated output-covariance matrix
ZZ(M, M)	measurement-covariance matrix
ZZEST(M, M)	estimated measurement-covariance matrix
AI(N2)	temporary storage array
AR(N2)	temporary storage array
ASI(KSIM, KSIM)	temporary storage array
BSIMQ(KSIM)	temporary storage array
EXT(N2, N2)	temporary storage array
EX1(N, N)	temporary storage array
EX2(N, N)	temporary storage array
EX3(N, N)	temporary storage array
EX4(N, N)	temporary storage array
EX5(N)	temporary storage array
EX6(N)	temporary storage array
IBL(N2)	temporary storage array (integer)
IPER(N2)	temporary storage array (integer)
IPERN(N2)	temporary storage array (integer)
JMAX(N2)	temporary storage array (integer)

TT(N2,N2) temporary storage array
 XR(N2,N2) temporary storage array

where N is the number of state variables, M is the number of measurements, C is the number of control inputs, R is the number of outputs, $N2 = 2 \times N$, and $KSIM = (N \times N + N) / 2$.

All these variables are dimensioned at compile time by NMAX, MMAX, CMAX, RMAX, N2MAX, and KSIMAX, where NMAX = 12, MMAX = 5, CMAX = 5, RMAX = 5, N2MAX = 24, and KSIMAX = 78. Integer array dimensions which the user must input in a data statement are N (less than or equal to 12), M (less than or equal to 5), C (less than or equal to 5), and R (less than or equal to 5). All variables are specifically dimensioned by NMAX, MMAX, CMAX, RMAX, N2MAX, and KSIMAX so that the user will not be forced to do any dimensioning. The maximum dimensions were chosen such that the problem would fit the 7094 storage capacity without need of overlay.

All data are input in block data format. Integer variables N, M, C, and R (which are dimensions) and ISORT (which is the option number) must always be input. Data statements for double-subscripted variables must be in the following column form, for example:

```
DATA ((VAR(I,J), I = 1,3), J = 1,2)
/1.0, 2 * 4.5, 85.4, 6.3, 6.0/
```

where matrix VAR is

$$\begin{bmatrix} 1.0 & 85.4 \\ 4.5 & 6.3 \\ 4.5 & 6.0 \end{bmatrix}$$

The specific data input and printed output are described for each option in the next sections.

The main routine LSOCE has an input variable, ISORT, which causes various subroutines to be called, depending on the option desired (see the next sections and the section LSOCE PROBLEM OPTIONS for further description).

The options available are

- (1) Infinite-time Kalman filter: calls subroutine ESTMAT only; calculates infinite-time KE and PP
- (2) Finite-time Kalman filter: calls subroutines ESTMAT and TRICCS; calculates infinite-time KE and PP and also KE and PP at each time point
- (3) Finite-time LSOCE problem without mean-square information: calls subroutines ESTMAT, TRICCS, CONTRL, and TRICCS; calculates infinite-time KE, PP, KC, and SS and also KE, PP, KC, and SS at each time point

(4) Finite-time LSOCE problem with mean-square information (the option used in the sample problem, appendix B): calls subroutines ESTMAT, TRICCS, CONTRL, TRICCS, and COVM; calculates all that option 3 does plus the mean-square, system-covariance matrices

(5) Infinite-time LSOCE problem: calls subroutines ESTMAT, CONTRL, and COVM; calculates infinite-time KE, PP, KC, and SS and the mean-square, system-covariance matrices.

(6) Infinite-time, noise-free regulator: calls subroutine CONTRL only; calculates infinite-time KC and SS

(7) Finite-time, noise-free regulator: calls subroutines CONTRL and TRICCS; calculates infinite-time KC and SS and also KC and SS at each time point

(8) Infinite-time regulator with plant noise: calls subroutines CONTRL and COVM; calculates infinite-time KC and SS and the mean-square, system-covariance matrices

(9) Open-loop, plant-covariance matrices: calls subroutine COVM only; calculates mean-square, system-covariance matrices

Option 1 - Infinite-Time Kalman Filter

The block data input for option 1 must include

ISORT	1
N	number of state variables, less than or equal to 12
M	number of measurements, less than or equal to 5
IOP1	1 if output from subroutine SCALE is desired 0 if output from subroutine SCALE is not desired
IOP2	1 if output from subroutine EGVCTR is desired 0 if output from subroutine EGVCTR is not desired
AA(N,N)	system matrix
HH(M,N)	measurement matrix
QQ(N,N)	power spectral density matrix of plant disturbance
RRINV(M,M)	inverse of power spectral density matrix of measurement noise

The output generated by option 1 is

(1) A top heading

```
*****  
RESULTS OF ESTIMATION PROBLEM  
*****
```

(2) The scaling vector (if $IOP1 \neq 0$) with the heading

TS, SCALING TRANSFORMATION MATRIX ELEMENTS

(3) Eigenvalues of the Hamiltonian matrix with the heading

REAL PART IMAGINARY PART ITER

where ITER is the number of iterations

(4) The modified eigenvector matrix of the Hamiltonian matrix (if $IOP2 \neq 0$) with the heading

MODIFIED EIGENVECTOR MATRIX OF AAA

(5) The ordered eigenvalues of the Hamiltonian matrix with the heading

THE ORDERED EIGENVALUES OF THE HAMILTONIAN MATRIX
THE CNES WITH NEGATIVE REAL PARTS
ARE THE EIGENVALUES OF $(A-KE*H)$
REAL PART IMAGINARY PART

(6) The solution to the estimation Riccati equation with the heading

PP, THE ESTIMATION ERROR COVARIANCE MATRIX

(7) The estimator-gain matrix with the heading

KE, THE KALMAN FILTER GAIN MATRIX

Option 2 - Finite-Time Kalman Filter

The block data input for option 2 must include

ISORT	2
N	number of state variables, less than or equal to 12
M	number of measurements, less than or equal to 5
IOP1	1 if output from subroutine SCALE is desired 0 if output from subroutine SCALE is not desired
IOP2	1 if output from subroutine EGVCTR is desired 0 if output from subroutine EGVCTR is not desired
DT	time step
NTAU	total number of time steps
AA(N, N)	system matrix

- HH(M, N) measurement matrix
- QQ(N, N) power spectral density matrix of plant disturbance
- RRINV(M, M) inverse of power spectral density matrix of measurement noise
- PPINIT(N, N) initial condition of transient Riccati solution for estimate

The output generated by option 2 is

- (1) A top heading

```
*****
                RESULTS OF ESTIMATION PROBLEM
*****
```

- (2) The scaling vector (if IOP1 \neq 0) with the heading

TS, SCALING TRANSFORMATION MATRIX ELEMENTS

- (3) Eigenvalues of the Hamiltonian matrix with the heading

REAL PART	IMAGINARY PART	ITER
-----------	----------------	------

where ITER is the number of iterations

- (4) The modified eigenvector matrix of the Hamiltonian matrix (if IOP2 \neq 0) with the heading

MODIFIED EIGENVECTOR MATRIX OF AAA

- (5) The ordered eigenvalues of the Hamiltonian matrix with the heading

```
THE ORDERED EIGENVALUES OF THE HAMILTONIAN MATRIX
THE ONES WITH NEGATIVE REAL PARTS
ARE THE EIGENVALUES OF (A-KE*H)
REAL PART                    IMAGINARY PART
```

- (6) The solution to the estimation Riccati equation with the heading

PP, THE ESTIMATION ERROR COVARIANCE MATRIX

- (7) The estimator-gain matrix with the heading

KE, THE KALMAN FILTER GAIN MATRIX

- (8) Followed by a top heading

```
*****
                TRANSIENT RICCATI SOLUTION
*****
```

- (9) A printout of time (The time initially will be 0.0.)

TIME = 0.

- (10) The solution to the Riccati differential equation with the heading

RICCATI SOLUTION MATRIX

(11) The transient estimator-gain matrix with the heading

KE, THE TRANSIENT ESTIMATE GAIN MATRIX

(Steps 9 to 11 are repeated for increasing time until NTAU steps have been taken.)

Option 3 - Finite-Time LSOCE Problem without Mean-Square Information

The block data for option 3 must include

ISORT	3
N	number of state variables, less than or equal to 12
M	number of measurements, less than or equal to 5
C	number of control inputs, less than or equal to 5
IOP1	1 if output from subroutine SCALE is desired 0 if output from subroutine SCALE is not desired
IOP2	1 if output from subroutine EGVCTR is desired 0 if output from subroutine EGVCTR is not desired
DT	time step
NTAU	total number of time steps
AA(N, N)	system matrix
HH(M, N)	measurement matrix
BB(N, C)	control input matrix
QC(N, N)	state weighting matrix
NN(N, N)	state-control product weighting matrix
QQ(N, N)	power spectral density matrix of plant disturbance
RRINV(M, M)	inverse of power spectral density matrix of measurement noise
PCINV(C, C)	inverse of control weighting matrix
PPINIT(N, N)	initial condition of transient Riccati solution for estimate
SSINIT(N, N)	initial condition of transient Riccati solution for control

The output generated by option 3 is

(1) A top heading

```
*****  
RESULTS OF ESTIMATION PROBLEM  
*****
```

M number of measurements, less than or equal to 5
C number of control inputs, less than or equal to 5
R number of outputs, less than or equal to 5
IOP1 1 if output from subroutine SCALE is desired
 0 if output from subroutine SCALE is not desired
IOP2 1 if output from subroutine EGVCTR is desired
 0 if output from subroutine EGVCTR is not desired
DT time step
NTAU total number of time steps
AA(N,N) system matrix
HH(M,N) measurement matrix
BB(N,C) control input matrix
QC(N,N) state weighting matrix
NN(N,N) state-control product weighting matrix
CC(R,N) output matrix
QQ(N,N) power spectral density matrix of plant disturbance
RRINV(M,M) inverse of power spectral density matrix of measurement noise
PCINV(C,C) inverse of control weighting matrix
PPINIT(N,N) initial condition of transient Riccati solution for estimate
SSINIT(N,N) initial condition of transient Riccati solution for control

The output generated by option 4 is

(1) A top heading

```
*****
                RESULTS OF ESTIMATION PROBLEM
*****
```

(2) The scaling vector (if IOP1 \neq 0) with the heading

TS, SCALING TRANSFORMATION MATRIX ELEMENTS

(3) Eigenvalues of the Hamiltonian matrix with the heading

REAL PART	IMAGINARY PART	ITER
-----------	----------------	------

where ITER is the number of iterations

(27) The estimated output-covariance matrix with the heading

YYEST, ESTIMATED OUTPUT COVARIANCE MATRIX

(28) The measurement-covariance matrix with the heading

ZZ, MEASUREMENT COVARIANCE MATRIX

(29) The estimated measurement-covariance matrix with the heading

ZZEST, ESTIMATED MEASUREMENT COVARIANCE MATRIX

Option 5 - Infinite-Time LSOCE Problem

The block data input for option 5 must include

ISORT	5
N	number of state variables, less than or equal to 12
M	number of measurements, less than or equal to 5
C	number of control inputs, less than or equal to 5
R	number of outputs, less than or equal to 5
IOP1	1 if output from subroutine SCALE is desired 0 if output from subroutine SCALE is not desired
IOP2	1 if output from subroutine EGVCTR is desired 0 if output from subroutine EGVCTR is not desired
AA(N,N)	system matrix
HH(M,N)	measurement matrix
BB(N,C)	control input matrix
QC(N,N)	state weighting matrix
NN(N,N)	state-control product weighting matrix
CC(R,N)	output matrix
QQ(N,N)	power spectral density matrix of plant disturbance
RRINV(M,M)	inverse of power spectral density matrix of measurement noise
PCINV(C,C)	inverse of control weighting matrix

The output generated by option 5 is

(1) A top heading

```
*****  
RESULTS OF ESTIMATION PROBLEM  
*****
```

(2) The scaling vector (if $IOP1 \neq 0$) with the heading

TS, SCALING TRANSFORMATION MATRIX ELEMENTS

(3) Eigenvalues of the Hamiltonian matrix with the heading

REAL PART IMAGINARY PART ITER

where ITER is the number of iterations

(4) The modified eigenvector matrix of the Hamiltonian matrix (if $IOP2 \neq 0$) with the heading

MODIFIED EIGENVECTOR MATRIX OF AAA

(5) The order eigenvalues of the Hamiltonian matrix with the heading

```
THE CRDERED EIGENVALUES OF THE HAMILTONIAN MATRIX  
THE ONES WITH NEGATIVE REAL PARTS  
ARE THE EIGENVALUES OF (A-KE*H)  
REAL PART                      IMAGINARY PART
```

(6) The solution to the estimation Riccati equation with the heading

PP, THE ESTIMATION ERROR COVARIANCE MATRIX

(7) The estimator-gain matrix with the heading

KE, THE KALMAN FILTER GAIN MATRIX

(8) Followed by a top heading

```
*****  
RESULTS OF CONTROL PROBLEM  
*****
```

(9) The scaling vector (if $IOP1 \neq 0$) with the heading

TS, SCALING TRANSFORMATION MATRIX ELEMENTS

(10) Eigenvalues of the Hamiltonian matrix with the heading

REAL PART IMAGINARY PART ITER

where ITER is the number of iterations

(11) The modified eigenvector matrix of the Hamiltonian matrix (if $IOP2 \neq 0$) with the heading

MODIFIED EIGENVECTOR MATRIX OF AAA

IOP1 1 if output from subroutine SCALE is desired
 0 if output from subroutine SCALE is not desired

IOP2 1 if output from subroutine EGVCTR is desired
 0 if output from subroutine EGVCTR is not desired

AA(N,N) system matrix

BB(N,C) control input matrix

QC(N,N) state weighting matrix

NN(N,N) state-control product weighting matrix

PCINV(C,C) inverse of control weighting matrix

The output generated by option 6 is

(1) A top heading

```
*****
                      RESULTS OF CONTROL PROBLEM
*****
```

(2) The scaling vector (if IOP1 \neq 0) with the heading

TS, SCALING TRANSFORMATION MATRIX ELEMENTS

(3) Eigenvalues of the Hamiltonian matrix with the heading

REAL PART	IMAGINARY PART	ITER
-----------	----------------	------

where ITER is the number of iterations

(4) The modified eigenvector matrix of the Hamiltonian matrix (if IOP2 \neq 0) with the heading

MODIFIED EIGENVECTOR MATRIX OF AAA

(5) The ordered eigenvalues of the Hamiltonian matrix with the heading

```
THE ORDERED EIGENVALUES OF THE HAMILTONIAN MATRIX
THE ONES WITH NEGATIVE REAL PARTS
ARE THE EIGENVALUES OF (A-B*KC)
REAL PART                      IMAGINARY PART
```

(6) The solution to the control Riccati equation with the heading

SS, MATRIX RICCATI SOLUTION FOR CONTROL PROBLEM

(7) The controller-gain matrix with the heading

KC, THE CONTROL GAIN MATRIX

Option 7 - Finite-Time, Noise-Free Regulator

The block data input for option 7 must include

ISORT	7
N	number of state variables, less than or equal to 12
C	number of control inputs, less than or equal to 5
IOP1	1 if output from subroutine SCALE is desired 0 if output from subroutine SCALE is not desired
IOP2	1 if output from subroutine EGVCTR is desired 0 if output from subroutine EGVCTR is not desired
DT	time step
NTAU	total number of time steps
AA(N,N)	system matrix
BB(N,C)	control input matrix
QC(N,N)	state weighting matrix
NN(N,N)	state-control product weighting matrix
PCINV(C,C)	inverse of control weighting matrix
SSINIT(N,N)	initial condition of transient Riccati solution for control

The output generated by option 7 is

(1) A top heading

```
*****
RESULTS OF CONTROL PROBLEM
*****
```

(2) The scaling vector (if IOP1 \neq 0) with the heading

TS, SCALING TRANSFORMATION MATRIX ELEMENTS

(3) Eigenvalues of the Hamiltonian matrix with the heading

REAL PART	IMAGINARY PART	ITER
-----------	----------------	------

where ITER is the number of iterations

(4) The modified eigenvector matrix of the Hamiltonian matrix (if IOP2 \neq 0) with the heading

MODIFIED EIGENVECTOR MATRIX OF AAA

IOP2 1 if output from subroutine EGVCTR is desired
 0 if output from subroutine EGVCTR is not desired

AA(N,N) system matrix

HH(M,N) measurement matrix

BB(N,C) control input matrix

QC(N,N) state weighting matrix

NN(N,N) state-control product weighting matrix

CC(R,N) output matrix

QQ(N,N) power spectral density matrix of plant disturbance

PP(N,N) estimation error-covariance matrix

PCINV(C,C) inverse of control weighting matrix

The output generated by option 8 is

(1) A top heading

```
*****
                RESULTS OF CONTROL PROBLEM
*****
```

(2) The scaling vector (if IOP1 \neq 0) with the heading

```
TS, SCALING TRANSFORMATION MATRIX ELEMENTS
```

(3) Eigenvalues of the Hamiltonian matrix with the heading

```
REAL PART        IMAGINARY PART                    ITER
```

where ITER is the number of iterations

(4) The modified eigenvector matrix of the Hamiltonian matrix (if IOP2 \neq 0) with the heading

```
MODIFIED EIGENVECTOR MATRIX OF AAA
```

(5) The ordered eigenvalues of the Hamiltonian matrix with the heading

```
THE ORDERED EIGENVALUES OF THE HAMILTONIAN MATRIX
THE ONES WITH NEGATIVE REAL PARTS
ARE THE EIGENVALUES OF (A-B*KC)
REAL PART                    IMAGINARY PART
```

(6) The solution to the control Riccati equation with the heading

```
SS, MATRIX RICCATI SOLUTION FOR CONTROL PROBLEM
```

(7) The controller gain matrix with the heading

```
KC, THE CONTROL GAIN MATRIX
```

(8) Followed by a top heading

```
*****  
COVARIANCE MATRICES  
*****
```

(9) The control-covariance matrix with the heading

UU CONTROL COVARIANCE MATRIX

(10) The state-covariance matrix with the heading

XX, STATE COVARIANCE MATRIX

(11) The output-covariance matrix with the heading

YY, OUTPUT COVARIANCE MATRIX

(12) The estimated output-covariance matrix with the heading

YYEST, ESTIMATED OUTPUT COVARIANCE MATRIX

(13) The measurement-covariance matrix with the heading

ZZ, MEASUREMENT COVARIANCE MATRIX

(14) The estimated measurement-covariance matrix with the heading

ZZEST, ESTIMATED MEASUREMENT COVARIANCE MATRIX

Option 9 - Open-Loop, Plant-Covariance Matrices

The block data input for option 9 must include

ISORT	9
N	number of state variables, less than or equal to 12
M	number of measurements, less than or equal to 5
C	number of control inputs, less than or equal to 5
R	number of outputs, less than or equal to 5
AA(N,N)	system matrix
HH(M,N)	measurement matrix
BB(N,C)	control input matrix
CC(R,N)	output matrix
QQ(N,N)	power spectral density matrix of plant disturbance
PP(N,N)	estimation error-covariance matrix

KC(C,N) control-gain matrix

The output generated by option 9 is

(1) A top heading

```
*****  
COVARIANCE MATRICES  
*****
```

(2) The control-covariance matrix with the heading

UU, CONTROL COVARIANCE MATRIX

(3) The state-covariance matrix with the heading

XX, STATE COVARIANCE MATRIX

(4) The output-covariance matrix with the heading

YY, OUTPUT COVARIANCE MATRIX

(5) The estimated output-covariance matrix with the heading

YYEST, ESTIMATED OUTPUT COVARIANCE MATRIX

(6) The measurement-covariance matrix with the heading

ZZ, MEASUREMENT COVARIANCE MATRIX

(7) The estimated measurement-covariance matrix with the heading

ZZEST, ESTIMATED MEASUREMENT COVARIANCE MATRIX

Listing of Main Routine LSOCE

```

C     MAIN PROGRAM
C
C     *****
C PLANT
C     XDOT = AA * X + BB * U + W
C MEASUREMENT
C     Z = H * X + V
C NOISE
C     COV(W) = QQ,      COV(V) = RR
C PERFORMANCE INDEX
C     J = E ( 1/2 * ( X**T * QC * X + X**T * NN * U + U**T * PC * U ) )
C
C     DIMENSIONS AND DESCRIPTIONS OF PROGRAM VARIABLES
C
C     A(N,N)           LYAPUNOV EQUATION MATRIX
C     AA(N,N)          SYSTEM MATRIX
C     AAA(2N,2N)       HAMILTONIAN MATRIX ASSOCIATED WITH THE
C                     RICCATI EQUATION
C     ANS(N,N)         RICCATI SOLUTION FROM TRICCS
C     BB(N,C)          CONTROL INPUT MATRIX
C     CC(R,N)          OUTPUT MATRIX
C     CI(2N)           EIGENVALUE IMAGINARY PARTS (OF AAA)
C     CR(2N)           EIGENVALUE REAL PARTS (OF AAA)
C     HH(M,N)          MEASUREMENT MATRIX
C     IOR(2N)          BLOCK DIAGONALIZING PERMUTATION VECTOR
C                     (INTEGER)
C     KC(C,N)          CONTROL GAIN MATRIX
C     KE(N,M)          ESTIMATOR GAIN MATRIX (REAL)
C     NBL(2N)          SIZE OF INDIVIDUAL IRREDUCIBLE BLOCKS
C                     (INTEGER)
C     NN(N,C)          STATE / CONTROL WEIGHTING MATRIX
C     PCINV(C,C)       INVERSE OF CONTROL WEIGHTING MATRIX
C     PP(N,N)          ESTIMATION ERROR COVARIANCE MATRIX
C     PPINIT(N,N)      INITIAL CONDITION OF RICCATI SOLUTION FOR
C                     TRANSIENT ESTIMATE PROBLEM
C     Q(N,N)           LYAPUNOV EQUATION MATRIX (SYMMETRIC)
C     QC(N,N)          STATE WEIGHTING MATRIX
C     QQ(N,N)          POWER SPECTRAL DENSITY MATRIX OF PLANT
C                     DISTURBANCE
C     RRINV(M,M)       INVERSE OF POWER SPECTRAL DENSITY MATRIX
C                     OF MEASUREMENT NOISE
C     SS(N,N)          CONTROL MATRIX RICCATI SOLUTION
C     SSINIT(N,N)      INITIAL CONDITION OF RICCATI SOLUTION FOR
C                     TRANSIENT CONTROL PROBLEM
C     TS(2N)          SCALING TRANSFORMATION
C     UU(C,C)          CONTROL COVARIANCE MATRIX
C     XI(2N,2N)        MODIFIED EIGENVECTOR MATRIX (OF AAA)
C     XX(N,N)          STATE COVARIANCE MATRIX (SYMMETRIC)
C     YY(R,R)          OUTPUT COVARIANCE MATRIX
C     YYEST(R,R)       ESTIMATED OUTPUT COVARIANCE MATRIX
C     ZZ(M,M)          MEASUREMENT COVARIANCE MATRIX
C     ZZEST(M,M)       ESTIMATED MEASUREMENT COVARIANCE MATRIX
C
C     DIMENSIONS OF TEMPORARY STORAGE ARRAYS
C
C     AI(2N)

```

```

C      AR(2N)
C      ASI((N*N+N)/2,(N*N+N)/2)
C      BSIMQ((N*N+N)/2)
C      EXT(2N,2N)
C      EX1(N,N)
C      EX2(N,N)
C      EX3(N,N)
C      EX4(N,N)
C      EX5(N)
C      EX6(N)
C      IBL(2N)                INTEGER
C      IPER(2N)               INTEGER
C      IPERN(2N)              INTEGER
C      JMAX(2N)               INTEGER
C      TT(2N,2N)
C      XR(2N,2N)
C
C      *****
C
C      DIMENSION  AA(12,12), QQ(12,12), QC(12,12), PP(12,12), SS(12,12),
1XX(12,12), A(12,12), Q(12,12), ANS(12,12), EX1(12,12), EX2(12,12),
2EX3(12,12), EX4(12,12), PPINIT(12,12), SSINIT(12,12), AAA(24,24),
3TT(24,24), EXT(24,24), X(24,24), XR(24,24), ASI(78,78), YY(5,5),
4ZZ(5,5), UU(5,5), YVEST(5,5), ZZEST(5,5), RRINV(5,5), PCINV(5,5),
5BB(12,5), NN(12,5), KE(12,5), KC(5,12), CC(5,12), HH(5,12),
6EX5(12), EX6(12), TS(24), CR(24), CI(24), AR(24), AI(24),
7IPER(24), IPERN(24), BSIMQ(78), IOR(24), NBL(24), IBL(24),
8JMAX(24)
C      REAL  KE, NN, KC
C      REAL  INIT
C      INTEGER  C, R, CMAX, RMAX
C
C      INSERT BLOCK DATA HERE
C
C      NMAX = 12
C      MMAX = 5
C      CMAX = 5
C      RMAX = 5
C      N2MAX = NMAX + NMAX
C      KMAX = NMAX * NMAX
C      KSIMAX = (KMAX + NMAX) / 2
C      N2=N+N
C      K=N*N
C      KSIM=(K+N)/2
C
C      IF (ISORT.GT.5) GO TO 10
C
C      CALL ESTMAT (AA,HH,QQ,RRINV,KE,PP,CR,CI,X,TS,XR,TT,AAA,EXT,AR,AI,
1IPER,IPERN,IOR,NBL,IBL,JMAX,N,M,N2,IOP1,IOP2,NMAX,MMAX,N2MAX)
C
C      IF (ISORT.EQ.1) STOP
C      IF (ISORT.EQ.5) GO TO 10
C
C      CALL TRICCS (X,PPINIT,CR,CI,ANS,DT,NTAU,N,C,M,N2,EX1,EX2,EX3,EX4,
1EX5,EX6,IPER,IPERN,HH,RRINV,NN,PCINV,BB,l,NMAX,CMAX,MMAX,N2MAX)
C
C      IF (ISORT.EQ.2) STOP
C      IF (ISORT.EQ.9) GO TO 20
C

```

```

CALL CONTRL (AA, BB, QC, NN, PCINV, KC, SS, CR, CI, X, TS, XR, TT, AAA, EXT, AR,
1AI, IPER, IPERN, IOR, NBL, IBL, JMAX, N, C, N2, IOP1, IOP2, NMAX, CMAX, N2MAX)
C
IF (ISORT.EQ.6) STOP
IF (ISORT.EQ.5.OR.ISORT.EQ.8) GO TO 20
C
CALL TRICCS (X, SSINIT, CR, CI, ANS, DT, NTAU, N, C, M, N2, EX1, EX2, EX3, EX4,
1EX5, EX6, IPER, IPERN, HH, RRINV, NN, PCINV, BB, 2, NMAX, CMAX, MMAX, N2MAX)
C
20 IF (ISORT.EQ.3.OR.ISORT.EQ.7) STOP
C
CALL COVM (AA, BB, HH, CC, QQ, PP, KC, N, M, C, R, XX, YY, ZZ, UU, YYEST, ZZEST,
1KSIM, A, Q, BSI MQ, ASI, NMAX, MMAX, CMAX, RMAX, KSI MAX)
C
RETURN
END

```

DESCRIPTIONS AND LISTINGS OF SUBROUTINES

Description of Subroutine ESTMAT

Subroutine ESTMAT solves the optimal linear state estimation problem. Using AA, HH, QQ, and RRINV, it sets up an $N2 \times N2$ matrix called AAA, which is the Hamiltonian matrix associated with the matrix Riccati equation. Subroutine ESTMAT then calls subroutine RICSS to solve the Riccati equation and to obtain the estimation error-covariance matrix PP, which subroutine ESTMAT then uses to compute the estimator gains KE.

The subroutine statement for ESTMAT is as follows:

```

SUBROUTINE ESTMAT (AA, HH, QQ, RRINV, KE, PP, CR, CI, X, TS, XR,
TT, AAA, EXT, AR, AI, IPER, IPERN, IOR, NBL,
IBL, JMAX, N, M, N2, IOP1, IOP2, NMAX, MMAX,
N2MAX)

```

The input variables are

AA(N, N)	system matrix
HH(M, N)	measurement matrix
QQ(N, N)	power spectral density matrix of plant disturbance
RRINV(M, M)	inverse of power spectral density matrix of measurement noise
IOP1	scaling printing option
IOP2	eigenvector printing option

The input integer dimensions are

N	number of state variables
M	number of measurements

N2 2×N, dimension of Hamiltonian matrix
 NMAX dimension, greater than or equal to N
 MMAX dimension, greater than or equal to M
 N2MAX dimension, greater than or equal to N2

The output variables are

PP(N, N) estimation error-covariance matrix
 KE(N, M) estimator-gain matrix

The intermediate variables are

AAA(N2, N2) Hamiltonian matrix associated with the Riccati equation
 CR(N2) real parts of eigenvalues of AAA
 CI(N2) imaginary parts of eigenvalues of AAA
 X(N2, N2) modified eigenvector matrix of AAA
 NBL(N2) size of each irreducible block (integer)
 IOR(N2) block-diagonalizing permutation vector (integer)
 TS(N2) scaling transformation

The temporary storage arrays are

XR(N2, N2)
 TT(N2, N2)
 EXT(N2, N2)
 AR(N2)
 AI(N2)
 IPER(N2) integer
 IPERN(N2) integer
 IBL(N2) integer
 JMAX(N2) integer

Vectors CR and CI contain the eigenvalues of the Kalman filter; that is, the eigenvalues of $(A - K_e H)$. If IOP1 is not equal to zero, the elements of the scaling transformation matrix are printed. If IOP2 is not equal to zero, the modified eigenvectors of AAA are printed.

There are no error messages output from this subroutine. It prints the following message:

DOUBLE PRECISION SUM
REAL KE

C
DIMENSION AA(NMAX,1), HH(MMAX,1), QQ(NMAX,1), RRINV(MMAX,1),
1 KE(NMAX,1), PP(NMAX,1), CR(1), CI(1), X(N2MAX,1), TS(1N,
2 XR(N2MAX,1), TT(N2MAX,1)T AAA(N2MAX,1), EXT(N2MAX,1), AR(1),
3 AI(1), IPER(1), IPERN(1), IOR(1), NBL(1), IBL(1), JMAX(1)

C
WRITE (6,130)

C
C
FORM AAA MATRIX

GO 50 J=1,N2
JJ=J-N
DO 50 I=1,N2
II=I-N
IF (J.GT.N) GO TO 20
IF (I.GT.N) GO TO 10
AAA(I,J)=-AA(J,I)
GO TO 50
10 AAA(I,J)=QQ(II,J)
GO TO 50
20 IF (I.GT.N) GO TO 40
SUM=0.000
DO 30 L=1,M
DO 30 K=1,M
30 SUM=SUM+HH(K,I)*RRINV(K,L)*HH(L,JJ)
AAA(I,J)=SUM
GO TO 50
40 AAA(I,J)=AA(II,JJ)
50 CONTINUE

C
C
OBTAIN SOLUTION TO ESTIMATION RICCATI EQ. AND STORE IN PP

C
CALL RICSS (AAA,X,PP,CR,CI,TS,XR,EXT,TT,IPER,IPERN,IOR,NBL,IBL,
1 JMAX,AR,AI,IOP1,IOP2,N,N2,NMAX,N2MAX)
WRITE (6,140)
WRITE (6,150) (CR(I),CI(I),I=1,N2)
WRITE (6,160)
LL=1
LLL=10
60 IF (N.LT.LLL) LLL=N
DO 70 I=1,N
WRITE (6,170) (PP(I,L),L=LL,LLL)
70 CONTINUE
WRITE (6,180)
IF (N.EQ.LLL) GO TO 80
LL=LL+10
LLL=LLL+10
GO TO 60

C
C
COMPUTE ESTIMATOR GAIN MATRIX KE

80 DO 100 J=1,M
DO 100 I=1,N
SUM=0.000
DO 90 L=1,M
DO 90 K=1,N
90 SUM=SUM+PP(I,K)*HH(L,K)*RRINV(L,J)

```

100  KE(I,J)=SUM
      WRITE (6,190)
      LL=1
      LLL=10
110  IF (M.LT.LLL) LLL=M
      DO 120 I=1,N
      WRITE (6,170) (KE(I,L),L=LL,LLL)
120  CONTINUE
      WRITE (6,180)
      IF (M.EQ.LLL) RETURN
      LL=LL+10
      LLL=LLL+10
      GO TO 110

C
130  FORMAT (1H1/1X,50H*****
1**/15X,29HRESULTS OF ESTIMATION PROBLEM/1X,50H*****
2*****//)
140  FORMAT (//1X,49HTHE ORDERED EIGENVALUES OF THE HAMILTONIAN MATRIX/
11X,33HTHE ONES WITH NEGATIVE REAL PARTS/1X,31HARE THE EIGENVALUES
20F (A-KE*H)/1X,9HREAL PART,14X,14HIMAGINARY PART)
150  FORMAT (1X,E15.8,8X,E15.8)
160  FORMAT (//1X,42HPP, THE ESTIMATION ERROR COVARIANCE MATRIX)
170  FORMAT (1X,1P10E12.4)
180  FORMAT (1H0)
190  FORMAT (//1X,33HKE, THE KALMAN FILTER GAIN MATRIX)
      END

```

Description of Subroutine CONTRL

Subroutine CONTRL solves the optimal linear regulator problem. Using AA, BB, QC, NN, and PCINV, it sets up an $N \times N$ matrix called AAA, which is the Hamiltonian matrix associated with the matrix Riccati equation. Subroutine CONTRL then calls subroutine RICSS to solve the Riccati equation and to obtain the control matrix Riccati solution SS, which subroutine CONTRL then uses to compute the control gains KC.

The subroutine statement for CONTRL is as follows:

```

SUBROUTINE CONTRL (AA,BB,QC,NN,PCINV,KC,SS,CR,CI,K,TS,
                  XR,TT,AAA,EXT,AR,AI,IPER,IPERN,IOR,
                  NBL,IBL,JMAX,N,C,N2,IOP1,IOP2,NMAX,
                  CMAX,N2MAX)

```

The input variables are

AA(N,N)	system matrix
BB(N,C)	control input matrix
QC(N,N)	state weighting matrix
NN(N,C)	state-control product weighting matrix
PCINV(C,C)	inverse of control weighting matrix

IOP1 scaling printing option
IOP2 eigenvector printing option

The input integer dimensions are

N number of state variables
C number of control inputs
N2 2×N, dimension of Hamiltonian matrix
NMAX dimension, greater than or equal to N
CMAX dimension, greater than or equal to C
N2MAX dimension, greater than or equal to N2

The output variables are

SS(N, N) matrix Riccati solution for control problem
KC(C, N) control-gain matrix

The intermediate variables are

AAA(N2, N2) Hamiltonian matrix associated with the Riccati equation
CR(N2) real parts of eigenvalues of AAA
CI(N2) imaginary parts of eigenvalues of AAA
X(N2, N2) modified eigenvector matrix of AAA
NBL(N2) size of each irreducible block (integer)
IOR(N2) block-diagonalizing permutation vector (integer)
TS(N2) scaling transformation

The temporary storage arrays are

XR(N2, N2)
TT(N2, N2)
EXT(N2, N2)
AR(N2)
AI(N2)
IPER(N2) integer
IPERN(N2) integer
IBL(N2) integer
JMAX(N2) integer

Vectors CR and CI contain the eigenvalues of the optimal linear regulator; that is, the eigenvalues of $(A - BK_c)$. If IOP1 is not equal to zero, the elements of the scaling transformation matrix are printed. If IOP2 is not equal to zero, the modified eigenvectors of AAA are printed.

There are no error messages output from this subroutine. It prints the following message:

```
*****
RESULTS OF CONTROL PROBLEM
*****
```

After the output from subroutines EGVCTR and RICSS, it prints the ordered eigenvalues with the heading

```
THE ORDERED EIGENVALUES OF THE HAMILTONIAN MATRIX
THE ONES WITH NEGATIVE REAL PARTS
ARE THE EIGENVALUES OF (A-B*KC)
REAL PART          IMAGINARY PART
```

It then prints the solution to the Riccati equation with the heading

```
SS, MATRIX RICCATI SOLUTION FOR CONTROL PROBLEM
```

Finally, it prints the K_c 's with the heading

```
KC, CONTROL GAIN MATRIX
```

The method used by subroutine CONTRL, given in reference 9, is as follows: subroutine CONTRL forms a $2n \times 2n$ Hamiltonian matrix M given as

$$M = \left[\begin{array}{c|c} -\left(A - BP_c^{-1}N^T\right) & \left(BP_c^{-1}B^T\right) \\ \hline \left(Q_c - NP_c^{-1}N^T\right) & \left(A - BP_c^{-1}N^T\right)^T \end{array} \right] \quad (29)$$

where the matrices A, B, N, P_c , and Q_c are defined in the section FINITE-TIME LSOCE PROBLEM. Matrix M is required as input to the Riccati-equation-solving subroutine RICSS. The particular Riccati equation solved is equation (13). After forming M, subroutine CONTRL calls subroutine RICSS to obtain the Riccati solution matrix S. It then computes the control gains K_c as

$$K_c = P_c^{-1} \left(B^T S + N^T \right) \quad (30)$$

Listing of Subroutine CONTRL

```

SUBROUTINE CONTRL (AA,BB,QC,NN,PCINV,KC,SS,CR,CI,X,TS,XR,TT,AAA,
1EXT,AR,AI,IPER,IPERN,IOR,NBL,IBL,JMAX,N,C,N2,IOP1,IOP2,NMAX,CMAX,
2N2MAX)

```

```

C
C *****
C CONTROL SOLVES OPTIMAL LINEAR REGULATOR PROBLEM. IT SETS UP N2 BY
C N2 MATRIX AAA, USING AA, BB, QC, NN, AND PCINV.
C CONTROL CALLS RICSS TO OBTAIN SOLUTION TO RICCATI EQUATION, SS.
C CCNTROL GAINS ARE THEN COMPUTED, KC.
C *****
C
C DOUBLE PRECISION SUM1, SUM2, SUM3
C REAL NN, KC
C INTEGER C, CMAX
C
C DIMENSION AA(NMAX,1), BB(NMAX,1), QC(NMAX,1), NN(NMAX,1),
1PCINV(CMAX,1), KC(CMAX,1), SS(NMAX,1), CR(1), CI(1), X(N2MAX,1),
2TS(1), XR(N2MAX,1), TT(N2MAX,1), AAA(N2MAX,1), EXT(N2MAX,1),
3AR(1), AI(1), IPER(1), IPERN(1), IOR(1), NBL(1), IBL(1), JMAX(1)
C
C WRITE (6,100)
C
C FORM AAA MATRIX
C
C DO 20 J=1,N
C JJ=J+N
C DO 20 I=1,N
C II=I+N
C SUM1=-AA(I,J)
C SUM2=QC(I,J)
C SUM3=0.000
C DO 10 L=1,C
C DO 10 K=1,C
C SUM1=SUM1+BB(I,K)*PCINV(K,L)*NN(J,L)
C SUM2=SUM2-NN(I,K)*PCINV(K,L)*NN(J,L)
10 SUM3=SUM3+BB(I,K)*PCINV(K,L)*BB(J,L)
C AAA(I,J)=SUM1
C AAA(JJ,II)=-SUM1
C AAA(II,J)=SUM2
20 AAA(I,JJ)=SUM3
C
C OBTAIN SOLUTION TO CONTROL RICCATI EQ. AND STORE IN SS
C
C CALL RICSS (AAA,X,SS,CR,CI,TS,XR,EXT,TT,IPER,IPERN,IOR,NBL,IBL,
1JMAX,AR,AI,IOP1,IOP2,N,N2,NMAX,N2MAX)
C WRITE (6,110)
C WRITE (6,120) (CR(I),CI(I),I=1,N2)
C WRITE (6,130)
C LL=1
C LLL=10
30 IF (N.LT.LLL) LLL=N
C DO 40 I=1,N
C WRITE (6,140) (SS(I,L),L=LL,LLL)
40 CONTINUE
C WRITE (6,150)
C IF (N.EQ.LLL) GO TO 50

```

```

LL=LL+10
LLL=LLL+10
GO TO 30
C
C COMPUTE CONTROL GAIN MATRIX KC
C
50 DC 70 J=1,N
DO 70 I=1,C
SUM1=0.000
DO 60 K=1,C
SUM1=SUM1+PC INV(I,K)*NN(J,K)
DO 60 L=1,N
60 SUM1=SUM1+PC INV(I,K)*BB(L,K)*SS(L,J)
70 KC(I,J)=SUM1
WRITE (6,160)
LL=1
LLL=10
80 IF (N.LT.LLL) LLL=N
DO 90 I=1,C
WRITE (6,140) (KC(I,L),L=LL,LLL)
90 CONTINUE
WRITE (6,150)
IF (N.EQ.LLL) RETURN
LL=LL+10
LLL=LLL+10
GO TO 80
C
100 FORMAT (1H1/1X,50H*****
1**/15X,26HRESULTS OF CONTROL PROBLEM/1X,50H*****
2*****//)
110 FORMAT (//1X,49HTHE ORDERED EIGENVALUES OF THE HAMILTONIAN MATRIX/
11X,33HTHE ONES WITH NEGATIVE REAL PARTS/1X,31HARE THE EIGENVALUES
20F (A-B*KC)/1X,9HREAL PART,14X,14HIMAGINARY PART)
120 FORMAT (1X,E15.8,8X,E15.8)
130 FORMAT (//1X,47HSS, MATRIX RICCATI SOLUTION FOR CONTROL PROBLEM)
140 FORMAT (1X,1P10E12.4)
150 FORMAT (1H0)
160 FORMAT (//1X,27HKC, THE CONTROL GAIN MATRIX)
END

```

Description of Subroutine RICSS

Subroutine RICSS computes the solution (called OUTPUT) to the algebraic Riccati equation. The input is an $N2 \times N2$ Hamiltonian matrix, AAA, formed by either subroutine ESTMAT or subroutine CONTRL. Subroutine RICSS calls subroutines CONDI, EIGQR, ORDER, EGVCTR, and the IBM SSP subroutines HSBG (upper Hessenberg transformation), ARRAY (conversion from vector storage to double-dimensioned storage or the reverse), and MINV (matrix inversion). Subroutine RICSS first conditions AAA (CONDI), then transforms it to upper Hessenberg form (HSBG) and computes its eigenvalues (EIGQR). The symmetric set of eigenvalues are then ordered (ORDER) (those with positive real parts occupying the first N positions), and the modified eigenvector

matrix is computed (EGVCTR) using the original AAA matrix. The matrix OUTPUT is then calculated by inverting and multiplying submatrices of the modified eigenvector matrix. For a detailed explanation of the method, see the following and reference 9.

The subroutine statement for RICSS is as follows:

```
SUBROUTINE RICSS (AAA,X,OUTPUT,CR,CI,TS,XR,EXT,TT,IPER,  
IPERN,IOR,NBL,IBL,JMAX,AR,AI,IOP1,  
IOP2,N,N2,NMAX,N2MAX)
```

The input variables are

AAA(N2,N2) Hamiltonian matrix associated with the Riccati equation
IOP1 scaling printing option (used in subroutine SCALE)
IOP2 eigenvector printing option (used in subroutine EGVCTR)

The input integer dimensions are

N number of state variables
N2 2×N
NMAX dimension, greater than or equal to N
N2MAX dimension, greater than or equal to N2

The output variable is

OUTPUT(N,N) matrix Riccati solution

The intermediate variables are

X(N2,N2) modified eigenvector matrix of AAA
CR(N2) real parts of eigenvalues of AAA
CI(N2) imaginary parts of eigenvalues of AAA
NBL(N2) size of each irreducible block (integer)
IOR(N2) block-diagonalizing permutation vector (integer)
TS(N2) scaling transformation vector

The temporary storage arrays are

XR(N2,N2)
EXT(N2,N2)
TT(N2,N2)
IPER(N2) integer
IPERN(N2) integer

IBL(N2) integer

JMAX(N2) integer

AR(N2)

AI(N2)

There is one error message from this subroutine. During calculation of OUTPUT, the upper left quadrant of the X matrix is inverted prior to multiplication by the lower left quadrant. The following message may then be printed:

X 11 IS SINGULAR

There is no other printed output from this subroutine.

The method used by subroutine RICSS is as follows: subroutine RICSS solves the algebraic Riccati equation

$$VM_{11} + M_{11}^T V - VM_{12} V + M_{21} = 0 \quad (31)$$

for an $n \times n$ positive-definite, symmetric matrix V. A $2n \times 2n$ Hamiltonian matrix M given by

$$M = \left[\begin{array}{c|c} M_{11} & M_{12} \\ \hline M_{21} & M_{22} \end{array} \right] \quad (32)$$

where $M_{22} = -M_{11}^T$, is required as input. The method consists of solving the equation

$$MT = T\Lambda \quad (33)$$

for the modified eigenvector matrix T, where Λ is defined as

$$\Lambda = \left[\begin{array}{c|c} C & O \\ \hline O & \overline{C} \end{array} \right] \quad (34)$$

C is the $n \times n$ block-diagonal matrix of the n eigenvalues of M that have positive real parts. The block-diagonal form of C is such that an eigenvalue pair $\lambda = \alpha \pm j\beta$ appears as a 2×2 block

$$C = \left[\begin{array}{c|c} \alpha & -\beta \\ \hline +\beta & \alpha \end{array} \right] \quad (35)$$

on the diagonal. Except that the diagonal elements of \bar{C} are all negative, \bar{C} is the same as C . Thus, with Λ so defined, the modified eigenvector matrix T is a block-diagonalizing transformation matrix of M .

After reducing and scaling M , transforming it to upper Hessenberg form, and obtaining its eigenvalues, subroutine RICSS calls subroutine ORDER, which sorts the eigenvalues into the required order. The modified eigenvector matrix of the original form of M is then computed by using subroutine EGVCTR to obtain T . The solution V is then obtained from the $n \times n$ submatrices of T as

$$V = T_{21} T_{11}^{-1} \quad (36)$$

Listing of Subroutine RICSS

```

SUBROUTINE RICSS (AAA,X,OUTPUT,CR,CI,TS,XR,EXT,TT,IPER,IPERN,IOR,
INEL,IBL,JMAX,AR,AI,IOP1,IOP2,N,N2,NMAX,N2MAX)
C
C *****
C RICSS COMPUTES SOLUTION TO STEADY STATE MATRIX RICCATI EQUATION,
C OUTPUT. INPUT IS N2 BY N2 MATRIX AAA, WHICH IS THE HAMILTONIAN
C MATRIX ASSOCIATED WITH THE MATRIX RICCATI EQUATION.
C RICSS CALLS CONDI, EIGQR, ORDER, EGVCTR AND IBM SSP SUBROUTINES
C HSBG, MINV, AND ARRAY.
C *****
C
C DOUBLE PRECISION SUM
C
C DIMENSION AAA(N2MAX,1), X(N2MAX,1), OUTPUT(NMAX,1), CR(1), CI(1),
ITS(1), XR(N2MAX,1), EXT(N2MAX,1), TT(N2MAX,1), IPER(1), IPERN(1),
ZAR(1), AI(1), IOR(1), NBL(1), IBL(1), JMAX(1)
C
C EPS IS THE ERROR CRITERION USED IN DETERMINING WHETHER TWO
C EIGENVALUES ARE SYMMETRIC ABOUT THE IMAGINARY AXIS
C
C EPS=.001
C
C PUT AAA IN BLOCK DIAGONAL FORM (IF REDUCIBLE) AND SCALE
C
C CALL CONDI (AAA,X,XR,IPER,IPERN,IOR,NBL,IBL,JMAX,TS,IOP1,N2,N2MAX)
C
C TRANSFORM CONDITIONED AND SCALED AAA TO UPPER HESSENBERG
C
C CALL ARRAY (2,N2,N2,N2MAX,N2MAX,XR,XR)
C CALL HSBG (N2,XR,N2)
C CALL ARRAY (1,N2,N2,N2MAX,N2MAX,XR,XR)
C
C OBTAIN EIGENVALUES OF HESSENBERG MATRIX
C
C CALL EIGQR (XR,N2,CR,CI,1,N2MAX)
C
C ORDER EIGENVALUES
C

```

```

      CALL ORDER (CR,CI,N2,EPS)
C
C   OBTAIN MODIFIED EIGENVECTOR MATRIX, X, USING ORIGINAL AAA MATRIX
C
      CALL EGVCTR (AAA,CR,CI,X,N2,TT,EXT,AR,AI,IIPERN,IIPER,IOP2,N2MAX)
30   DO 40 J=1,N
      DO 40 I=1,N
40   OUTPUT(I,J)=X(I,J)
C
C   INVERT X11
C
      CALL ARRAY (2,N,N,NMAX,NMAX,OUTPUT,OUTPUT)
      CALL MINV (OUTPUT,N,DET,IIPERN,IIPER)
      CALL ARRAY (1,N,N,NMAX,NMAX,OUTPUT,OUTPUT)
      IF (DET.EQ.0.0) WRITE (6,110)
C
C   PREMULTIPLY X11 INVERSE BY X21 TO OBTAIN RICCATI SOLUTION, OUTPUT
C
      DO 70 J = 1,N
      DO 60 I = 1,N
      II=I+N
      SUM=0.000
      DO 50 K = 1,N
50   SUM=SUM+X(II,K)*OUTPUT(K,J)
60   AR(I)=SUM
      DO 70 M = 1,N
70   OUTPUT(M,J)=AR(M)
      RETURN
C
110  FORMAT (1X,15HX11 IS SINGULAR)
      END

```

Description of Subroutine CONDI

Subroutine CONDI conditions an $N \times N$ matrix, VARO, before the eigenvalues of VARO are obtained. This conditioning is done in order to improve the accuracy of the eigenvalues. The matrix VARO is first transformed into block-diagonal form (if reducible) and then each individual block is scaled. In order to accomplish this, subroutine CONDI calls subroutines REDU and SCALE. If VARO is not reducible, it is simply scaled.

The subroutine statement for CONDI is as follows:

```

SUBROUTINE CONDI (VARO,SS,S,IN,JBL,IOR,NBL,IBL,JMAX,D,
                 IOP1,N,NMAX)

```

The input variables are

VARO(N,N) matrix to be conditioned
IOP1 scaling printing option (used in subroutine SCALE)

The input integer dimensions are

N size of matrix to be reduced and scaled
NMAX dimension, greater than or equal to N

The output variable is

S(N,N) matrix in block-diagonal and scaled form

The intermediate variables are

D(N) vector containing the diagonal elements of the diagonal scaling matrix
IOR(N) block-diagonalizing permutation vector (integer)
NBL(N) size of each irreducible block (integer)

The temporary storage arrays are

SS(N,N)
IN(N) integer
JBL(N) integer
IBL(N) integer
JMAX(N) integer

There is no printed output from this subroutine.

Listing of Subroutine CONDI

```
      SUBROUTINE CONDI (VARO,SS,S,IN,JBL,IOR,NBL,IBL,JMAX,D,IOPL,N,NMAX)
C
C *****
C CHANGE CONDITION OF MATRIX BY PUTTING IT IN BLOCK DIAGONAL FORM
C (IF REDUCIBLE) AND THEN SCALING.
C CONDI CALLS SUBROUTINES REDU AND SCALE.
C *****
C
C   DIMENSION  VARO(NMAX,1), SS(NMAX,1), S(NMAX,1), IN(1), JBL(1),
1  IOR(1), NBL(1), IBL(1), D(1), JMAX(1)
C
C   CALL REDU (VARO,SS,S,IN,JBL,INBL,IOR,NBL,IBL,JMAX,N,NMAX)
DO 10 I = 1,N
10  C(I) = 1.0
     NSUM = 0
     DO 30 K = 1,INBL
     NSMOLD = NSUM + 1
     NSUM = NBL(K) + NSUM
     IF (NBL(K) .LE. 1) GO TO 30
     DO 20 J = NSMOLD,NSUM
     JJ = J - NSMOLD + 1
     DO 20 I = NSMOLD,NSUM
```

```

      II = I - NSMOLD + 1
20  SS(II, JJ) = S(I, J)
      CALL SCALE (SS, D(NSMOLD), NBL(K), IOPI, NMAX)
30  CONTINUE
      DO 40 J = 1, N
      DO 40 I = 1, N
40  S(I, J) = S(I, J) * D(J) / D(I)
      RETURN
      END

```

Description of Subroutine REDU

Subroutine REDU reduces an $N \times N$ matrix VARO, if VARO is reducible. A simple permutation transformation is used on VARO. Subroutine REDU calls no subroutines.

The subroutine statement for REDU is as follows:

```

SUBROUTINE REDU (VARO, SS, S, IN, JBL, INBL, IOR, NEL, IBL, JMAX,
                N, NMAX)

```

The input variable is

VARO(N, N) matrix to be reduced to block-diagonal form

The input integer dimensions are

N size of matrix to be reduced

NMAX dimension, greater than or equal to N

The output variables are

S(N, N) matrix in block-diagonal form

NBL(N) size of each irreducible block (integer)

INBL number of irreducible blocks (integer)

The intermediate variable is

IOR(N) block-diagonalizing permutation vector (integer)

The temporary storage arrays are

SS(N, N)

IN(N) integer

JBL(N) integer

IBL(N) integer

JMAX(N) integer

There is no printed output from this subroutine.

The following is a simplified description of the subroutine REDU algorithm, which is based on Harary's method for reducing a matrix to block-diagonal form (ref. 15). The aim is to permute the rows and columns of a matrix A so that (if possible) the following block-diagonal form results:

$$\left[\begin{array}{c|c} A_{11} & A_{12} \\ \hline 0 & A_{22} \end{array} \right]$$

A Boolean matrix B corresponding to the input matrix A is formed by inserting ones in the positions of B where nonzero entries occur in A and zeroes elsewhere. For example,

$$A = \begin{array}{c} \begin{array}{ccccc} & 1 & 2 & 3 & 4 & 5 \\ \begin{array}{c} 1 \\ 2 \\ 3 \\ 4 \\ 5 \end{array} & \left[\begin{array}{ccccc} C2 & C8 & 0 & C9 & 0 \\ 0 & 0 & 0 & C3 & 0 \\ C10 & C11 & C1 & 0 & 0 \\ 0 & C4 & 0 & C5 & C6 \\ 0 & 0 & 0 & C7 & 0 \end{array} \right] \end{array} & \begin{array}{c} \begin{array}{ccccc} & 1 & 2 & 3 & 4 & 5 \\ \begin{array}{c} 1 \\ 2 \\ 3 \\ 4 \\ 5 \end{array} & \left[\begin{array}{ccccc} 1 & 1 & 0 & 1 & 0 \\ 0 & 0 & 0 & 1 & 0 \\ 1 & 1 & 1 & 0 & 0 \\ 0 & 1 & 0 & 1 & 1 \\ 0 & 0 & 0 & 1 & 0 \end{array} \right] \end{array} \end{array}$$

Matrix B is raised to the $n - 1$ power by using the rules of Boolean multiplication and addition. Then, the resulting matrix is checked for coincident ones, that is, where ones appear in both the (i, j) and the (j, i) positions when $i \neq j$. This checking is done to find which variables are associated with irreducible submatrices of A . In this example, B^{n-1} is

$$B^4 = \begin{array}{c} \begin{array}{ccccc} & 1 & 2 & 3 & 4 & 5 \\ \begin{array}{c} 1 \\ 2 \\ 3 \\ 4 \\ 5 \end{array} & \left[\begin{array}{ccccc} 1 & 1 & 0 & 1 & 1 \\ 0 & 1 & 0 & 1 & 1 \\ 1 & 1 & 1 & 1 & 1 \\ 0 & 1 & 0 & 1 & 1 \\ 0 & 1 & 0 & 1 & 1 \end{array} \right] \end{array} \end{array}$$

The coincident ones occur in locations $(2, 5 \text{ and } 5, 2)$, $(2, 4 \text{ and } 4, 2)$, and $(4, 5 \text{ and } 5, 4)$. Thus, variables 2 and 5, 2 and 4, and 4 and 5 are associated with irreducible submatrices. However, 2 is common to the first two submatrices and 4 is common to the

last two submatrices. Thus, 2, 4, and 5 are all associated with one 3x3 irreducible submatrix. Therefore, the grouping of variables is (2, 4, 5), (1), and (3).

Now that the variables associated with the irreducible submatrices are identified, the original matrix A is rearranged into block-diagonal form. The rows and columns of A are permuted so that the variables associated with each irreducible submatrix are adjacent. An INBLxINBL Boolean matrix B is formed, whose off-diagonal elements are ones if any of the elements in the corresponding block of the permuted A matrix are nonzero; otherwise, they are zero. All diagonal elements of B must be set to 1. For example,

$$\begin{array}{c}
 A = \\
 \text{(permuted form)}
 \end{array}
 \begin{array}{c}
 \begin{array}{ccccc}
 & 2 & 4 & 5 & 1 & 3 \\
 2 & \left[\begin{array}{ccc|cc}
 0 & C3 & 0 & 0 & 0 \\
 4 & C4 & C5 & C6 & 0 & 0 \\
 5 & 0 & C7 & 0 & 0 & 0 \\
 \hline
 1 & C8 & C9 & 0 & C2 & 0 \\
 \hline
 3 & C11 & 0 & 0 & C10 & C1
 \end{array} \right]
 \end{array}
 \end{array}
 \quad
 \begin{array}{c}
 \begin{array}{ccc}
 & 1 & 2 & 3 \\
 1 & \left[\begin{array}{ccc}
 1 & 0 & 0 \\
 2 & 1 & 1 & 0 \\
 3 & 1 & 1 & 1
 \end{array} \right]
 \end{array}
 \end{array}
 \end{array}$$

The B matrix is checked to see which column has the most zeroes. Then the block of A corresponding to that column is placed in the first position, and that row and column of B are eliminated. Thus, in this example, the third block of A is placed in the first position, and B is changed by eliminating the third row and third column, resulting in

$$\begin{array}{c}
 B = \\
 \begin{array}{cc}
 & 1 & 2 \\
 1 & \left[\begin{array}{cc}
 1 & 0 \\
 2 & 1 & 1
 \end{array} \right]
 \end{array}
 \end{array}$$

The process is repeated; for example, the second block of A is placed in the second position and the second row and column of B are eliminated, resulting in

$$\begin{array}{c}
 B = 1 \left[\begin{array}{c} 1 \end{array} \right]
 \end{array}$$

Finally, the first block of A is placed in the third position. The final A is now in the correct block-diagonal form with the irreducible blocks on the diagonal.

$$A \text{ (final form)} = \begin{matrix} & \begin{matrix} 3 & 1 & 2 & 4 & 5 \end{matrix} \\ \begin{matrix} 3 \\ 1 \\ 2 \\ 4 \\ 5 \end{matrix} & \begin{bmatrix} C1 & C10 & C11 & 0 & 0 \\ 0 & C2 & C8 & C9 & 0 \\ 0 & 0 & 0 & C3 & 0 \\ 0 & 0 & C4 & C5 & C6 \\ 0 & 0 & 0 & C7 & 0 \end{bmatrix} \end{matrix}$$

Listing of Subroutine REDU

```

SUBROUTINE REDU (VARO,SS,S,IN,JBL,INBL,IOR,NBL,IBL,JMAX,N,NMAX)
C
C *****
C HARARYS METHOD FOR REDUCTION OF A REDUCIBLE MATRIX TO BLOCK
C DIAGONAL FORM. REDU CALLS NO SUBROUTINES.
C *****
C
DIMENSION VARO(NMAX,1), SS(NMAX,1), S(NMAX,1), IN(1), JBL(1),
1 IOR(1), NBL(1), IBL(1), JMAX(1)
INBL = 0
DO 5 I = 1,N
IN(I) = 0
JBL(I) = 0
IOR(I) = 0
NBL(I) = 0
JMAX(I) = 0
5 IBL(I) = 0
C
C TAKE S MATRIX WHICH IS VARO MATRIX TO THE N-1 POWER IN BOOLEAN
C
DO 10 I = 1,N
IN(I) = I
DO 10 J = 1,N
10 SS(I,J) = VARO(I,J)
IF (N .GT. 2) GO TO 30
DO 20 J = 1,N
DO 20 I = 1,N
S(I,J) = 0.0
IF (VARO(I,J) .NE. 0.0) S(I,J) = 1.0
20 CONTINUE
GO TO 80
30 N2 = N - 2
DO 70 L = 1,N2
DO 60 I = 1,N
DO 60 K = 1,N
S(K,I) = 0.0
DO 40 J = 1,N
IF (VARO(K,J) .NE. 0.0 .AND. SS(J,I) .NE. 0.0) GO TO 50
40 CONTINUE
GO TO 60
50 S(K,I) = 1.0

```

```

60 CONTINUE
   DO 70 J = 1,N
   DO 70 I = 1,N
70  SS(I,J) = S(I,J)
C
C   FIND EQUIVALENCE BLOCKS AND IDENTIFY
C
80  INBL = 1
   KSUM = 1
90  KSUMO = KSUM
   DO 130 I = 1,N
   DO 130 J = 1,N
   IF (I .EQ. J) GO TO 130
   IF (S(I,J) .NE. S(J,I)) GO TO 130
   IF (IN(I) .EQ. 0 .AND. IN(J) .EQ. 0) GO TO 130
   IF (S(I,J) .EQ. 0.0 .AND. S(J,I) .EQ. 0.0) GO TO 130
   IF (KSUMO .NE. KSUM) GO TO 100
   IN(I) = 0
   IOR(KSUM) = I
   IN(J) = 0
   ICR(KSUM+1) = J
   KSUM = KSUM + 2
   GO TO 130
100 K1 = KSUM - 1
   DO 110 L = KSUMO,K1
   IF (IOR(L) .NE. I) GO TO 110
   IF (IN(J) .EQ. 0) GO TO 130
   IN(J) = 0
   IOR(KSUM) = J
   KSUM = KSUM + 1
110 CONTINUE
   DO 120 L = KSUMO,K1
   IF (IOR(L) .NE. J) GO TO 120
   IF (IN(I) .EQ. 0) GO TO 130
   IN(I) = 0
   IOR(KSUM) = I
   KSUM = KSUM + 1
120 CONTINUE
130 CONTINUE
   IF (KSUMO .NE. KSUM) GO TO 150
   DO 140 I = 1,N
   IF (IN(I) .EQ. 0) GO TO 140
   NBL(INBL) = 1
   INBL = INBL + 1
   ICR(KSUM) = IN(I)
   IN(I) = 0
   KSUM = KSUM + 1
140 CONTINUE
   INBL = INBL - 1
   KSUM = KSUM - 1
   GO TO 180
150 NBL(INBL) = KSUM - KSUMO
   NSUM = 0
   DO 160 I = 1,INBL
   NSUM = NBL(I) + NSUM
160 CONTINUE
   IF (NSUM .NE. N) GO TO 170
   KSUM = KSUM - 1
   GO TO 180

```



```

170 INBL = INBL + 1
    GO TO 90
C
C REARRANGE MATRIX TO FORM EQUIVALENCE BLOCKS
C
180 DO 190 I = 1,N
    K = IOR(I)
    DO 190 J = 1,N
190 SS(I,J) = VARO(K,J)
    DO 200 J = 1,N
    K = IOR(J)
    DO 200 I = 1,N
200 S(I,J) = SS(I,K)
C
C MAKE BOOLEAN MATRIX FROM EQUIVALENCE BLOCKS
C
NSUM = 0
DO 210 L = 1,INBL
NSMOLD = NSUM + 1
NSUM = NSUM + NBL(L)
JSUM = 0
DO 210 K = 1,INBL
JSMOLD = JSUM + 1
JSUM = JSUM + NBL(K)
SS(L,K) = 0.0
DO 210 J = JSMOLD,JSUM
DO 210 I = NSMOLD,NSUM
IF (S(I,J) .NE. 0.0) SS(L,K) = 1.0
210 CONTINUE
DO 220 I = 1,INBL
IBL(I) = NBL(I)
IF (SS(I,I) .NE. 1.0) SS(I,I) = 1.0
220 CONTINUE
C
C REARRANGE EQUIVALENCE BLOCKS IN ORDER OF BOOLEAN COLUMNS WITH
C DECREASING NUMBERS OF ZEROES
C S = MATRIX IN EQUIVALENCE BLOCK ORDER
C INBL = NUMBER OF EQUIVALENCE BLOCKS
C NBL(I) = SIZE OF ITH BLOCK, (I = 1,...INBL)
C IBL(I) = NBL(I)
C ICR(J) = NEW ORDER OF ROWS AND COLUMNS OF S IN COMPARISON
C WITH VARO, (J = 1,...N)
C SS = BOOLEAN MATRIX OF EQUIVALENCE BLOCKS IN S
C
INBL1 = INBL - 1
INew = INBL
INUM = 0
IVAR = 1
230 IMAx = 0
IZERMX = 0
DO 250 J = 1,INBL
IZER = 0
DO 240 I = 1,INBL
IF (INUM .EQ. 0) GO TO 245
DO 235 JJJ = 1,INUM
IF (J .EQ. JMAX(JJJ)) GO TO 250
IF (I .EQ. JMAX(JJJ)) GO TO 240
235 CONTINUE
245 IF (SS(I,J) .EQ. 0.0) IZER = IZER + 1
240 CONTINUE

```

```

IF (IZER .LE. IZERMX) GO TO 250
IZERMX = IZER
IMAX = J
250 CONTINUE
INUM = INUM + 1
JMAX(INUM) = IMAX
KBL = INBL - INEW + 1
IF (IMAX .EQ. 0) GO TO 260
JBL(KBL) = IBL(IMAX)
IBL(IMAX) = 0
GO TO 290
260 DO 280 I = KBL, INBL
DO 270 J = 1, INBL
IF (IBL(J) .EQ. 0) GO TO 270
JBL(I) = IBL(J)
IBL(J) = 0
GO TO 280
270 CONTINUE
280 CONTINUE
290 IF (IZERMX .EQ. 0) GO TO 340
NSUM = 0
DO 300 I = 1, IMAX
300 NSUM = NSUM + NBL(I)
NSMOLD = NSUM - NBL(IMAX) + 1
DO 310 I = NSMOLD, NSUM
J = IVAR + I - NSMOLD
IN(J) = IOR(I)
310 IOR(I) = 0
IVAR = IVAR + NSUM - NSMOLD + 1
INEW = INEW - 1
IF (INEW .LE. 0) GO TO 370
GO TO 230
340 DO 360 I = 1, N
IF (IN(I) .NE. 0) GO TO 360
DO 350 J = 1, N
IF (IOR(J) .EQ. 0) GO TO 350
IN(I) = IOR(J)
IOR(J) = 0
GO TO 360
350 CONTINUE
360 CONTINUE
C
C REARRANGE ROWS AND COLUMNS OF ORIGINAL MATRIX VARD TO FORM FINAL
C MATRIX S IN BLOCK DIAGONAL FORM
C
370 CONTINUE
DO 380 I = 1, INBL
380 NBL(I) = JBL(I)
DO 390 I = 1, N
IOR(I) = IN(I)
K = IOR(I)
DO 390 J = 1, N
390 SS(I, J) = VARO(K, J)
DO 400 J = 1, N
K = IOR(J)
DO 400 I = 1, N
400 S(I, J) = SS(I, K)
RETURN
END

```

Description of Subroutine SCALE

Subroutine SCALE transforms an irreducible $N2 \times N2$ matrix A, by using a diagonal matrix TS, so that the norm of A is minimized. The purpose of using subroutine SCALE is to condition A so that accuracy is improved in taking its eigenvalues. The resulting scaled matrix is stored in A. Subroutine SCALE calls no subroutines. See reference 9 for further description.

The subroutine statement for SCALE is as follows:

```
SUBROUTINE SCALE (A,TS,N2,IOP1,N2MAX)
```

The input variables are

A(N2,N2) matrix to be scaled
IOP1 controls printing option

The input integer dimensions are

N2 size of matrix to be scaled
N2MAX dimension, greater than or equal to N2

The output variables are

A(N2,N2) input matrix in scaled form
TS(N2) vector containing the diagonal elements of the diagonal scaling matrix

There are no error messages output from this subroutine. If IOP1 is not equal to zero, the TS vector is printed with the heading

```
TS, SCALING TRANSFORMATION MATRIX ELEMENTS
```

Listing of Subroutine SCALE

```
      SUBROUTINE SCALE (A,TS,N2,IOP1,N2MAX)
C
C *****
C SCALE TRANSFORMS N2 BY N2 MATRIX A USING DIAGONAL MATRIX TS SO
C THAT THE NORM OF A IS MINIMIZED. THE RESULTING SCALED MATRIX IS
C STORED IN A. SCALE CALLS NO SUBROUTINES.
C *****
C
C      DOUBLE PRECISION  YNUM, XDEN
C
C      DIMENSION  A(N2MAX,1), TS(1)
C
C      DC 10 I=1,N2
10     TS(I)=1.0
20     K=0
      FLAG=1.0
```

```

30   K=K+1
      YNUM=0.0D0
      XCEN=0.0D0
      DO 40 I=1,N2
      IF (I.EQ.K) GO TO 40
      YNUM=YNUM+A(I,K)*A(I,K)
      XDEN=XDEN+A(K,I)*A(K,I)
40   CONTINUE
      SC=YNUM/XDEN
      SD=SD**-.25
      IF (K.EQ.N2) GO TO 60
      DO 50 J=1,N2
      DO 50 I=1,N2
      IF (I.NE.K.AND.J.NE.K) GO TO 50
      IF (I.EQ.K.AND.J.EQ.K) GO TO 50
      IF (I.NE.K.AND.J.EQ.K) A(I,J)=A(I,J)/SD
      IF (I.EQ.K.AND.J.NE.K) A(I,J)=A(I,J)*SD
50   CONTINUE
      TS(K)=TS(K)*SD
      GO TO 90
60   CONTINUE
      DO 70 J=1,N2
      DO 70 I=1,N2
      IF (I.NE.K.AND.J.NE.K) GO TO 70
      IF (I.EQ.K.AND.J.EQ.K) GO TO 70
      IF (I.NE.K.AND.J.EQ.K) A(I,J)=A(I,J)/SD
      IF (I.EQ.K.AND.J.NE.K) A(I,J)=A(I,J)*SD
70   CONTINUE
      NN2=N2-1
      DO 80 I=1,NN2
80   TS(I)=TS(I)/SD
90   CONTINUE
C
C   IF TS HAS NOT CHANGED BY MORE THAN 10 PERCENT, SCALING IS COMPLETE
C
      IF (SD.LT.1.1.AND.SD.GT..90) GO TO 100
      FLAG=0.0
100  IF (K.LT.N2) GO TO 30
      IF (FLAG.EQ.1.0) GO TO 110
      GO TO 20
110  DO 120 I=1,N2
120  TS(I)=1.0/TS(I)
      IF (IOPI.EQ.0) RETURN
      WRITE (6,130)
      WRITE (6,140) (TS(I),I=1,N2)
      RETURN
C
130  FORMAT (1X,42HTS, SCALING TRANSFORMATION MATRIX ELEMENTS)
140  FORMAT (1X,1P10E12.3/3X,1P10E12.3)
      END

```

Description of Subroutine EIGQR

Subroutine EIGQR computes the eigenvalues of a real matrix XR, by using the QR algorithm of Francis (refs. 16 and 17). The input matrix must be in upper Hessenberg

form. The maximum number of iterations of the QR algorithm used in finding an eigenvalue is 50. Subroutine EIGQR calls no subroutines.

The subroutine statement for EIGQR is as follows:

```
SUBROUTINE EIGQR (XR,N2,CR,CI,IOP,N2MAX)
```

The input variables are

XR(N2,N2) input matrix in upper Hessenberg form

IOP controls printing option

The input integer dimensions are

N2 size of input matrix

N2MAX dimension, greater than or equal to N2

The output variables are

CR(N2) real parts of eigenvalues

CI(N2) imaginary parts of eigenvalues

There is one error message from subroutine EIGQR. If it cannot find the eigenvalue or eigenvalues in 50 iterations, it prints

```
THE FOLLOWING ANSWER(S) DID NOT CONVERGE
```

If IOP is not zero, the output from subroutine EIGQR prints the list of real parts and imaginary parts of the eigenvalues with the number of QR iterations associated in obtaining each one. The heading is

```
REAL PART      IMAGINARY PART      ITER
```

Listing of Subroutine EIGQR

```
SUBROUTINE EIGQR (XR,N2,CR,CI,IOP,N2MAX)
C
C *****
C EIGQR COMPUTES THE EIGENVALUES USING THE QR ALGORITHM. THE INPUT
C MATRIX MUST BE IN UPPER HESSENBERG FORM. THE MAXIMUM NUMBER OF
C ITERATIONS IS 50. EIGQR CALLS NO SUBROUTINES.
C *****
C
C DIMENSION XR(N2MAX,1), CR(1), CI(1), PSI(2), GR(3)
C
C FPZ=1.0E-15
C N=N2
C DO 10 I=1,N
C CR(I)=0.0
10 CI(I)=0.0
C IF (IOP) 20,30,20
```

```

20  WRITE (6,800)
30  ZERO=0.0
    JJ=1
40  XNN=0.0
    XN2=0.0
    AA=0.0
    B=0.0
    C=0.0
    DD=0.0
    R=0.0
    SIG=0.0
    ITER=0
    IF (N-2) 50,100,110
50  IF (IOP) 60,70,60
60  WRITE (6,810) XR(1,1)
70  CR(1)=XR(1,1)
    CI(1)=0.0
80  CONTINUE
    NE=N2/2
    DO 90 I=1,NE
    NN=N2-I+1
    B=CR(I)
    C=CI(I)
    CR(I)=CR(NN)
    CI(I)=CI(NN)
    CR(NN)=B
90  CI(NN)=C
    RETURN
100 JJ=-1
110 Y=(XR(N-1,N-1)-XR(N,N))**2
    S=4.0*XR(N,N-1)*XR(N-1,N)
    ITER=ITER+1
    IF (ABS(S)-Y*1.0E-8) 120,120,160
120 IF (ABS(XR(N-1,N-1))-ABS(XR(N,N))) 140,130,130
130 E=XR(N-1,N-1)
    G=XR(N,N)
    GO TO 150
140 G=XR(N-1,N-1)
    E=XR(N,N)
150 F=0.0
    H=0.0
    GO TO 230
160 T=Y+S
    IF (ABS(T)-4MAX1(Y,ABS(S))*1.0E-6) 170,170,180
170 T=0.0
180 Y=XR(N-1,N-1)+XR(N,N)
    SQ=SQRT(ABS(T))
    IF (T) 220,190,190
190 F=0.0
    H=0.0
    IF (Y) 210,200,200
200 E=(Y-SQ)/2.0
    G=(Y+SQ)/2.0
    GO TO 230
210 G=(Y-SQ)/2.0
    E=(Y+SQ)/2.0
    GO TO 230
220 F=SQ/2.0
    E=Y/2.0

```

```

G=E
F=F
230 IF (JJ) 250,240,240
240 C=1.0E-10*(ABS(G)+F)
    IF (ABS(XR(N-1,N-2)).GT.D) GO TO 280
250 IF (IOP) 260,270,260
260 WRITE (6,810) E,F,ITER
    WRITE (6,810) G,H
270 CR(N)=E
    CI(N)=F
    CR(N-1)=G
    CI(N-1)=H
    N=N-2
    IF (JJ) 80,40,40
280 IF (ABS(XR(N,N-1)).GT.1.0E-10*ABS(XR(N,N))) GO TO 320
290 IF (IOP) 300,310,300
300 WRITE (6,810) XR(N,N),ZERO,ITER
310 CR(N)=XR(N,N)
    CI(N)=0.0
    N=N-1
    GO TO 40
320 VQ=ABS(XR(N,N-1))-ABS(XR(N-1,N-2))
    IF (ABS(ABS(XN2/XR(N-1,N-2))-1.0)-1.0E-6) 340,340,330
330 IF (ABS(ABS(XNN/XR(N,N-1))-1.0)-1.0E-6) 340,340,350
340 IF (VQ) 290,250,250
350 IF (ITER.LT.50) GO TO 360
    WRITE (6,820)
    IF (VQ) 290,250,250
360 IF (ITER.GT.5) GO TO 380
    Z1=ABS(E-AA)+ABS(F-B)-.5*(ABS(E)+ABS(F))
    Z2=ABS(G-C)+ABS(H-DD)-.5*(ABS(G)+ABS(H))
    IF (Z1) 370,400,400
370 IF (Z2) 380,390,390
380 R=E*G-F*H
    SIG=E+G
    GO TO 430
390 R=E*E
    SIG=E+E
    GO TO 430
400 IF (Z2) 410,420,420
410 R=C*G
    SIG=G+G
    GO TO 430
420 R=0.0
    SIG=0.0
430 XNN=XR(N,N-1)
    XN2=XR(N-1,N-2)
    N1=N-1
    IA=N-2
    IP=IA
    IF (N-3) 480,480,440
440 DO 470 J=3,N1
    J1=N-J
    IF (ABS(XR(J1+1,J1))-D) 480,480,450
450 DEN=XR(J1+1,J1+1)*(XR(J1+1,J1+1)-SIG)+XR(J1+1,J1+2)*XR(J1+2,J1+1)+
1R
    IF (DEN) 460,470,460
460 IF (ABS(XR(J1+1,J1)*XR(J1+2,J1+1))*(ABS(XR(J1+1,J1+1)+XR(J1+2,J1+2
1)-SIG)+ABS(XR(J1+3,J1+2)))-ABS(DEN)*D) 490,490,470
470 IP=J1

```

```

48C  IQ=IP
      GO TO 520
490  IP1=IP-1
      IQ=IP1
      IF (IP1-1) 520,520,500
500  DO 510 J=2,IP1
      J1=IP-J+1
      IF (ABS(XR(J1+1,J1))-0) 520,520,510
510  IQ=IQ-1
520  DO 790 I=IP,N1
      IF (I-IP) 540,530,540
530  GR(1)=XR(IP,IP)*(XR(IP,IP)-SIG)+XR(IP,IP+1)*XR(IP+1,IP)+R
      GR(2)=XR(IP+1,IP)*(XR(IP,IP)+XR(IP+1,IP+1)-SIG)
      GR(3)=XR(IP+1,IP)*XR(IP+2,IP+1)
      XR(IP+2,IP)=0.0
      GO TO 570
540  GR(1)=XR(I,I-1)
      GR(2)=XR(I+1,I-1)
      IF (I-IA) 550,550,560
550  GR(3)=XR(I+2,I-1)
      GO TO 570
560  GR(3)=0.0
570  CONTINUE
      IF (ABS(GR(1)).LT.FPZ) GR(1)=0.0
      IF (ABS(GR(2)).LT.FPZ) GR(2)=0.0
      IF (ABS(GR(3)).LT.FPZ) GR(3)=0.0
      XK=SIGN(SQRT(GR(1)**2+GR(2)**2+GR(3)**2),GR(1))
      IF (XK) 580,590,580
580  PSI(1)=GR(2)/(GR(1)+XK)
      PSI(2)=GR(3)/(GR(1)+XK)
      IF (ABS(PSI(1)).LT.FPZ) PSI(1)=0.0
      IF (ABS(PSI(2)).LT.FPZ) PSI(2)=0.0
      AL=GR(1)/XK+1.0
      GO TO 600
590  AL=2.0
      PSI(1)=0.0
      PSI(2)=0.0
600  IF (I-IQ) 610,640,610
610  IF (I-IP) 630,620,630
620  XR(I,I-1)=-XR(I,I-1)
      GO TO 640
630  XR(I,I-1)=-XK
640  DO 690 J=I,N
      IF (I-N1) 650,660,660
650  DR=PSI(2)*XR(I+2,J)
      GO TO 670
660  CR=0.0
670  ER=AL*(XR(I,J)+PSI(1)*XR(I+1,J)+DR)
      IF (ABS(ER).LT.FPZ) ER=0.0
      XR(I,J)=XR(I,J)-ER
      XR(I+1,J)=XR(I+1,J)-PSI(1)*ER
      IF (I-N1) 680,690,690
680  XR(I+2,J)=XR(I+2,J)-PSI(2)*ER
690  CONTINUE
      IF (I-N1) 700,710,710
700  L=I+2
      GO TO 720
710  L=N
720  DO 770 J=IQ,L

```



```

      IF (I-N1) 730,740,740
730  DR=PSI(2)*XR(J,I+2)
      GO TO 750
740  CR=0.0
750  ER=AL*(XR(J,I)+PSI(1)*XR(J,I+1)+DR)
      IF (ABS(ER).LT.FPZ) ER=0.0
      XR(J,I)=XR(J,I)-ER
      XR(J,I+1)=XR(J,I+1)-PSI(1)*ER
      IF (I-N1) 760,770,770
760  XR(J,I+2)=XR(J,I+2)-PSI(2)*ER
770  CONTINUE
      IF (I-1A) 780,790,790
780  ER=AL*PSI(2)*XR(I+3,I+2)
      IF (ABS(ER).LT.FPZ) ER=0.0
      XR(I+3,I)=-ER
      XR(I+3,I+1)=-PSI(1)*ER
      XR(I+3,I+2)=XR(I+3,I+2)-PSI(2)*ER
790  CONTINUE
      AA=E
      B=F
      C=G
      DD=H
      GO TO 110

C
800  FORMAT (///1X,9HREAL PART,6X,14HIMAGINARY PART,45X,4HITER//)
810  FORMAT (1X,E15.8,3X,E15.8,42X,I3)
820  FORMAT (1X,40HTHE FOLLOWING ANSWER(S) DID NOT CONVERGE)
      END

```

Description of Subroutine ORDER

Given a set of NE eigenvalues stored in vectors CR and CI and symmetrically located with respect to the imaginary axis, subroutine ORDER places ones with positive real parts in the first NE/2 locations of CR and CI. Corresponding symmetric eigenvalues with negative real parts are placed in locations (NE/2) + 1 through NE of CR and CI. The convergence criterion EPS is used in determining if a pair of eigenvalues is symmetric. Subroutine ORDER calls no subroutines.

The subroutine statement for ORDER is as follows:

```
SUBROUTINE ORDER (CR,CI,NE,EPS)
```

The input variables are

CR(NE)	real parts of eigenvalues (not ordered)
CI(NE)	imaginary parts of eigenvalues (not ordered)
EPS	criterion for symmetry

The input integer dimension is

NE	number of eigenvalues
----	-----------------------

The output variables are

CR(NE) real parts of eigenvalues (ordered)

CI(NE) imaginary parts of eigenvalues (ordered)

There is one error message from this subroutine. When an eigenvalue pair (λ_i, λ_j) , where $\lambda_i = \alpha_i + j\beta_i$, is not symmetric within the ϵ criterion, that is, $\left[\frac{(|\alpha_i| - |\alpha_j|)}{|\alpha_i|} \right] \leq \epsilon$, the program will stop and the following message will be printed:

EIGENVALUES ARE NOT SYMMETRIC

There is no other printed output from this subroutine.

Listing of Subroutine ORDER

```

SUBROUTINE ORDER (CR,CI,NE,EPS)
C
C *****
C GIVEN A SET OF NE EIGENVALUES, SYMMETRICALLY LOCATED WITH RESPECT
C TO THE IMAGINARY AXIS. ORDER PLACES ONES WITH POSITIVE REAL PARTS
C IN FIRST NE/2 LOCATIONS. CORRESPONDING SYMMETRIC EIGENVALUES
C WITH NEGATIVE REAL PARTS ARE PUT IN LOCATIONS NE/2 + 1 THRU NE.
C EPS IS CONVERGENCE CRITERION USED IN DETERMINING IF PAIR OF EIGEN-
C VALUES ARE SYMMETRIC. ORDER CALLS NO SUBROUTINES.
C *****
C
C DIMENSION CR(1), CI(1)
C
C NE2=NE/2
C KMAX=NE2+1
C IMAX=NE+1
C K=0
C
C PUT EIGENVALUES WITH POSITIVE REAL PARTS IN TOP HALVES OF CR AND
C CI AND REST IN BOTTOM HALVES
C
10 K=K+1
20 IF (K.EQ.KMAX) GO TO 40
   IF (CR(K).GT.0.0) GO TO 10
   TCR=CR(K)
   TCI=CI(K)
   I=K+1
30 L=I-1
   CR(L)=CR(I)
   CI(L)=CI(I)
   I=I+1
   IF (I.NE.IMAX) GO TO 30
   CR(NE)=TCR
   CI(NE)=TCI
   GO TO 20
40 CONTINUE
```

```

      K=C
C
C   REARRANGE EIGENVALUES WITH NEGATIVE REAL PARTS SO THAT
C   CR(I + NE/2) = -CR(I)
C
50  K=K+1
    L=NE2+K
    IF (K.EQ.KMAX) GO TO 80
60  IF (ABS((CR(K)+CR(L))/CR(K)).LT.EPS) GO TO 70
    L=L+1
    IF (L.LE.NE) GO TO 60
    WRITE (6,90)
    STOP
70  TCR=CR(L)
    TCI=CI(L)
    M=NE2+K
    CR(L)=CR(M)
    CI(L)=CI(M)
    CR(M)=TCR
    CI(M)=TCI
    GO TO 50
80  CONTINUE
    RETURN
C
90  FORMAT (1X,29HEIGENVALUES ARE NOT SYMMETRIC)
    END

```

Description of Subroutine EGVCTR

Subroutine EGVCTR obtains the $N2 \times N2$ modified eigenvector matrix X , given the real input matrix AAA and its eigenvalues CPR and CPI . The modified eigenvector matrix differs from the eigenvector matrix only in that where a complex pair of eigenvectors (columns) would occur in the eigenvector matrix, the corresponding two columns in the modified eigenvector matrix contain the real plus the imaginary parts and the real minus the imaginary parts, respectively. The internal variable $IEND$ specifies the number of passes which will be made through the inverse iteration algorithm in obtaining each eigenvector. It is set nominally at 4. Subroutine EGVCTR calls subroutine PRMUTE and the IBM SSP subroutines FACTR and ARRAY.

The subroutine statement for EGVCTR is as follows:

```

SUBROUTINE EGVCTR (AAA,CPR,CPI,X,N2,TT,EXT,AR,AI,
                  IPERN,IPER,IOP2,N2MAX)

```

The input variables are

AAA(N2, N2)	matrix for which eigenvectors are to be obtained
CPR(N2)	real parts of eigenvalues of AAA
CPI(N2)	imaginary parts of eigenvalues of AAA

IOP2 controls printing option

The input integer dimensions are

N2 size of matrix for which eigenvectors are to be found

N2MAX dimension, greater than or equal to N2

The output variable is

X(N2, N2) modified eigenvector matrix of AAA

The temporary storage arrays are

TT(N2, N2)

EXT(N2, N2)

AR(N2)

AI(N2)

IPERN(N2) integer

IPER(N2) integer

If IBM SSP subroutine FACTR finds that the matrix cannot be factored, it returns with an error signal. Subroutine EGVCTR reads this signal and, if there is an error, it prints a message. If it is a real eigenvector, it prints

FACTR IS WRONG

If it is a complex eigenvector, it prints

FACTR 2 IS WRONG

If IOP2 is not 0, the modified eigenvector matrix is written with the heading

MODIFIED EIGENVECTOR MATRIX OF AAA

Subroutine EGVCTR uses the inverse iteration method of Wilkinson (ref. 18) to solve the eigenvector problem $Aq = \lambda q$, given an $n \times n$ matrix A and an eigenvalue λ . The inverse iteration algorithm for finding q is given by Wilkinson as

$$(A - \lambda I)z^{i+1} = q^i \quad (37)$$

$$q^{i+1} = \frac{z^{i+1}}{(z^{i+1})_{\max}} \quad (38)$$

where $(z^{i+1})_{\max}$ is the element of z^{i+1} having the largest magnitude and q^i is the i^{th} approximation to the eigenvector q. Initially, q^0 is chosen to be all ones. Vector q^i

usually converges to the true eigenvector after only a few iterations. Since $(A - \lambda I)$ is almost singular (except for computational errors), it is not inverted in solving for z^{i+1} but (as suggested by Wilkinson) is factored into lower and upper triangular factors, L and U, by using IBM SSP subroutine FACTR. Subroutine FACTR obtains L and U such that

$$P(A - \lambda I) = LU \quad (39)$$

where P is a permutation matrix accounting for row interchanges which occurred in performing the factoring. Once the factors are obtained, it is easy to solve equation (37) for z^{i+1} . To do this, we can write

$$P(A - \lambda I)z^{i+1} = Pq^i \quad (40)$$

If we let

$$y^{i+1} = Uz^{i+1} \quad (41)$$

then

$$Ly^{i+1} = Pq^i \quad (42)$$

which can be solved for y^{i+1} by using forward substitution (solving first for the first element of y^{i+1}). Having obtained y^{i+1} , we obtain z^{i+1} by back substitution (solving first for the last element of z^{i+1}). The iteration is continued until $q^i \approx q^{i+1}$ (three or four iterations have been found to suffice). Note that IBM SSP subroutine FACTR need only be called once for each value of λ .

The preceding algorithm can be used either for λ -real or λ -complex. However, to avoid using complex arithmetic for the complex case, equations (37) and (38) can be expanded as follows: let $\lambda = \alpha + j\beta$, where $\beta \geq 0$, and its corresponding eigenvector $q = q_R + jq_I$. Then we can write

$$[(A - \alpha I) - j\beta I](z_R^{i+1} + jz_I^{i+1}) = q_R^i + jq_I^i \quad (43)$$

and

$$q_R^{i+1} + jq_I^{i+1} = \frac{z_R^{i+1} + jz_I^{i+1}}{\left(\frac{z_R^{i+1}}{\max}\right) + j\left(\frac{z_I^{i+1}}{\max}\right)} \quad (44)$$

Following Wilkinson, equation (43) can be expanded and separated into two equations, resulting in

$$Cz_R^{i+1} = Dq_R^i - \beta q_I^i \quad (45)$$

and

$$Dz_R^{i+1} + \beta z_I^{i+1} = q_R^i \quad (46)$$

where

$$C \triangleq \beta^2 I + (A - \alpha I)^2 \quad (47)$$

and

$$D \triangleq A - \alpha I \quad (48)$$

Matrix C can be factored (as was done previously for A in the real eigenvector case) as $PC = LU$. Then we can write

$$y_R^{i+1} = Uz_R^{i+1} \quad (49)$$

so that equation (45) becomes

$$Ly_R^{i+1} = PDq_R^i - P\beta q_I^i \quad (50)$$

Now equation (50) is solved for y_R^{i+1} , and then z_R^{i+1} is solved by means of back substitution while using equation (49). Next, equation (46) can be rewritten as

$$z_I^{i+1} = \frac{q_R^i - Dz_R^{i+1}}{\beta} \quad (51)$$

which can easily be solved for z_I^{i+1} .

Then, equation (44) can be expanded into the two equations

$$q_R^i = \frac{z_R^{i+1} \left(z_R^{i+1} \right)_{\max} + z_I^{i+1} \left(z_I^{i+1} \right)_{\max}}{\left| z_{\max}^{i+1} \right|^2} \quad (52)$$

```

C      DOUBLE PRECISION  SUM, SUM1
C
C      DIMENSION  AAA(N2MAX,1), CPR(1), CPI(1), X(N2MAX,1), TT(N2MAX,1),
1EXT(N2MAX,1), AR(1), AI(1), IPER(1), IPERN(1)
C
C      DO 10 J=1,N2
C      DO 10 I=1,N2
10     X(I,J)=1.0
C      IEND=4
C
C
C      L=1
20     IF (L.GT.N2) GO TO 450
C      DO 30 J=1,N2
C      DO 30 I=1,N2
C      EXT(I,J)=AAA(I,J)
C      IF (I.EQ.J) EXT(I,J)=EXT(I,J)-CPR(L)
30     CONTINUE
C      IF (CPI(L).NE.0.0) GO TO 180
C
C      CALCULATE REAL EIGENVECTOR
C
C      FACTOR LHS MATRIX INTO LOWER AND UPPER TRIANGULAR FACTORS
C
C      CALL ARRAY (2,N2,N2,N2MAX,N2MAX,EXT,EXT)
C      CALL FACTR (EXT,AR,N2,N2,IER)
C      CALL ARRAY (1,N2,N2,N2MAX,N2MAX,EXT,EXT)
C      DO 40 I=1,N2
40     IPERN(I)=AR(I)
C      IF (IER.NE.3) GO TO 50
C      WRITE (6,490)
50     CONTINUE
C
C      CHECK FOR ZEROS ON DIAGONAL OF UPPER TRIANGULAR MATRIX
C
C      DO 80 I=1,N2
C      IF (EXT(I,I).NE.0.0) GO TO 80
C      II=I+1
C      AMAX=ABS(EXT(I,II))
C      IF (I.EQ.N2) AMAX=1.0
C      IF (II.GE.N2) GO TO 60
C      II=I+2
60     DO 70 J=II,N2
C      IF (ABS(EXT(I,J)).GT.AMAX) AMAX=ABS(EXT(I,J))
70     CONTINUE
C      IF (AMAX.EQ.0.0) AMAX=1.0
C      EXT(I,I)=.5*AMAX/(2.0**35)
80     CONTINUE
C      ITER=0
C      GO TO 130
C
C      GO TO BACK SUBSTITUTION PHASE
C
C
90     ITER=ITER+1
C      IF (ITER.NE.IEND) GO TO 100
C      L=L+1
C      GO TO 20
100    CONTINUE
C      CALL PRMUTE (X,IPERN,IPER,N2,L,N2MAX)
C

```



```

C      BEGIN FORWARD SUBSTITUTION
C
      DO 120 I=2,N2
      M=I-1
      SUM=X(I,L)
      DO 110 J=1,M
110    S(M)=SUM-EXT(I,J)*X(J,L)
120    X(I,L)=SUM
      X(N2,L)=X(N2,L)/EXT(N2,N2)
C
C      BEGIN BACKWARD SUBSTITUTION
C
130    DO 150 I=2,N2
      J=N2-I+1
      M=J+1
      SUM=X(J,L)
      DO 140 K=M,N2
140    S(M)=SUM-X(K,L)*EXT(J,K)
150    X(J,L)=SUM/EXT(J,J)
      IZ=1
      ZMAX=ABS(X(1,L))
      DO 160 I=2,N2
      ZINT=ABS(X(I,L))
      IF (ZINT.LE.ZMAX) GO TO 160
      ZMAX=ZINT
      IZ=I
160    CONTINUE
      ZMAX=X(IZ,L)
      DO 170 I=1,N2
      X(I,L)=X(I,L)/ZMAX
170    IF (ABS(X(I,L)).LT.1.0E-10) X(I,L)=0.0
      GO TO 90
C
C      CALCULATE COMPLEX EIGENVECTOR
C
C      FORM LHS MATRIX (BETA**2 + ( A - ALPHA*I )**2 )
C
180    DO 190 J=1,N2
      DO 190 I=1,N2
190    TT(I,J)=EXT(I,J)
      DO 220 J=1,N2
      DO 210 I=1,N2
      SUM=0.000
      DO 200 K=1,N2
200    S(M)=SUM+TT(I,K)*EXT(K,J)
210    AR(I)=SUM
      DO 220 M=1,N2
      EXT(M,J)=AR(M)
      IF (M.EQ.J) EXT(M,J)=AR(M)+CPI(L)*CPI(L)
220    CONTINUE
C
C      FACTOR LHS MATRIX INTO LOWER AND UPPER TRIANGULAR FACTORS
C
      CALL ARRAY (2,N2,N2,N2MAX,N2MAX,EXT,EXT)
      CALL FACTR (EXT,AR,N2,N2,IER)
      CALL ARRAY (1,N2,N2,N2MAX,N2MAX,EXT,EXT)
230    IPERN(I)=AR(I)
      IF (IER.NE.3) GO TO 240

```

```

WRITE (6,500)
240 CONTINUE
C
C CHECK FOR ZEROS ON DIAGONAL OF UPPER TRIANGULAR MATRIX
C
DO 270 I=1,N2
AR(I)=1.0
IF (EXT(I,I).NE.0.0) GO TO 270
II=I+1
AMAX=ABS(EXT(I,II))
IF (I.EQ.N2) AMAX=1.0
IF (II.GE.N2) GO TO 250
II=I+2
250 DO 260 J=II,N2
IF (ABS(EXT(I,J)).GT.AMAX) AMAX=ABS(EXT(I,J))
260 CONTINUE
IF (AMAX.EQ.0.0) AMAX=1.0
EXT(I,I)=.5*AMAX/(2.0**35)
270 CONTINUE
ITER=0
LL=L+1
C
C GO TO BACK SUBSTITUTION PHASE
C
GO TO 360
ITER=ITER+1
280 IF (ITER.NE.IEND) GO TO 290
GO TO 430
C
C FORM RHS VECTOR FOR FINDING REAL PART OF EIGENVECTOR PAIR
C
290 CONTINUE
DO 300 I=1,N2
AR(I)=X(I,L)
300 AI(I)=X(I,LL)
DO 320 I=1,N2
SUM=C.000
DO 310 J=1,N2
310 SUM=SUM+TT(I,J)*AR(J)
320 X(I,L)=SUM
CALL PRMUTE (X,IPERN,IPER,N2,L,N2MAX)
CALL PRMUTE (X,IPERN,IPER,N2,LL,N2MAX)
DO 330 I=1,N2
330 X(I,L)=-X(I,LL)*ABS(CPI(L))+X(I,L)
C
C BEGIN FORWARD SUBSTITUTION
C
DO 350 I=2,N2
M=I-1
SUM=X(I,L)
DO 340 J=1,M
340 SUM=SUM-EXT(I,J)*X(J,L)
350 X(I,L)=SUM
X(N2,L)=X(N2,L)/EXT(N2,N2)
C
C BEGIN BACKWARD SUBSTITUTION
C
360 DO 380 I=2,N2
J=N2-I+1
M=J+1

```

```

SUM=X(J,L)
DO 370 K=M,N2
370 SUM=SUM-X(K,L)*EXT(J,K)
380 X(J,L)=SUM/EXT(J,J)
DO 400 I=1,N2
SUM=AR(I)
DO 390 K=1,N2
390 SUM=SUM-TT(I,K)*X(K,L)
400 X(I,LL)=SUM/ABS(CPI(LL))
C
C BEGIN NORMALIZATION OF EIGENVECTORS
C
IZ=1
ZMAX=X(I,L)*X(I,L)+X(I,LL)*X(I,LL)
DO 410 I=2,N2
ZINT=X(I,L)*X(I,L)+X(I,LL)*X(I,LL)
IF (ZINT.LE.ZMAX) GO TO 410
ZMAX=ZINT
IZ=I
410 CONTINUE
XRMAX=X(IZ,L)
XIMAX=X(IZ,LL)
DO 420 I=1,N2
XR=(X(I,L)*XRMAX+X(I,LL)*XIMAX)/ZMAX
XI=(X(I,LL)*XRMAX-X(I,L)*XIMAX)/ZMAX
X(I,L)=XR
X(I,LL)=XI
IF (ABS(X(I,L)).LT.1.0E-10) X(I,L)=0.0
IF (ABS(X(I,LL)).LT.1.0E-10) X(I,LL)=0.0
420 CONTINUE
GO TO 280
C
C ADD AND SUBTRACT COLUMNS OF X TO FORM MODIFIED EIGENVECTOR MATRIX
C
430 DO 440 I=1,N2
SUM=X(I,L)
X(I,L)=SUM+X(I,LL)
440 X(I,LL)=SUM-X(I,LL)
L=L+2
GO TO 20
C
C END OF COMPLEX EIGENVECTOR CALCULATION
C
C PRINT OUT EIGENVECTOR MATRIX
C
450 IF (IOP2.EQ.0) GO TO 480
WRITE (6,510)
LL=1
LLL=10
460 IF (N2.LT.LLL) LLL=N2
DO 470 I=1,N2
WRITE (6,520) (X(I,L),L=LL,LLL)
470 CONTINUE
WRITE (6,530)
IF (N2.EQ.LLL) GO TO 480
LL=LL+10
LLL=LLL+10
GO TO 460
480 CONTINUE
RETURN

```

```

C
490  FORMAT (1H0,14HFACTR IS WRONG)
500  FORMAT (1H0,16HFACTR 2 IS WRONG)
510  FORMAT (//20X,34HMODIFIED EIGENVECTOR MATRIX OF AAA)
520  FORMAT (1X,1P10E12.4)
530  FORMAT (1H0)
      END

```

Description of Subroutine PRMUTE

Subroutine PRMUTE permutes elements in column LA of an NE×NE matrix X, as dictated by the transposition vector ITRANS, which is produced by IBM SSP subroutine FACTR. Subroutine PRMUTE calls no subroutines.

The subroutine statement for PRMUTE is as follows:

```
SUBROUTINE PRMUTE (X,ITRANS,IA,NE,LA,NEMAX)
```

The input variables are

X(NE, NE) input matrix
ITRANS(NE) transposition vector
LA column of X to be permuted

The input integer dimensions are

NE size of X matrix
NEMAX dimension, greater than or equal to NE

The output variable is

X(NE, NE) input matrix in permuted form

The temporary storage array is

IA(NE) integer

There is no printed output from this subroutine.

The method used by subroutine PRMUTE is as follows: given a set of linear equations to be solved,

$$Ax = b \quad (56)$$

IBM SSP subroutine FACTR can be used to solve the equation

$$PA = LU \quad (57)$$

for P, L, and U, given A, where P is a permutation matrix, L is lower triangular, and U is upper triangular. Thus, if factoring is used, the original problem becomes

$$PAx = Pb$$

(58)

or

$$LUx = Pb$$

(59)

This equation can be easily solved for x by forward and backward substitution (see the section Description of Subroutine EGVCTR). Subroutine PRMUTE is used to take permutation information represented by matrix P , which is output from IBM SSP subroutine FACTR and stored in vector ITRANS, and to permute the elements of b to form Pb . However, subroutine PRMUTE considers vector b to be the LA column of an $NE \times NE$ matrix X .

Listing of Subroutine PRMUTE

```
      SUBROUTINE PRMUTE (X,ITRANS,IA,NE,LA,NEMAX)
C
C *****
C PRMUTE PERMUTES ELEMENTS IN LA COLUMN OF NE BY NE MATRIX X AS
C   DICTATED BY TRANSPOSITION VECTOR ITRANS. ITRANS IS PRODUCED,
C   IN OUR CASE, BY SUBROUTINE FACTR. IT CALLS NO SUBROUTINES.
C *****
C
C   DIMENSION X(NEMAX,1), ITRANS(1), IA(1)
C
C   DO 10 I=1,NE
10    IA(I)=I
      DO 60 JJ=1,NE
      J=NE+1-JJ
      ITRN=ITRANS(J)
      I=C
20    I=I+1
      IF (IA(I).EQ.ITRN) GO TO 30
      GO TO 20
30    L=0
40    L=L+1
      IF (IA(L).EQ.J) GO TO 50
      GO TO 40
50    XTEMP=X(L,LA)
      X(L,LA)=X(I,LA)
      X(I,LA)=XTEMP
      IA(L)=ITRN
      IA(I)=J
60    CONTINUE
      RETURN
      END
```

Description of Subroutine COVM

Subroutine COVM computes various covariance matrices that describe the system which represents the solution to the LSOCE problem. It sets up matrices for subroutine LYPNV (Lyapunov equation), which is then called to obtain the state-covariance matrix **XX**. Then **XX**, the estimation error covariance **PP**, and the control gains **KC** are used to obtain various other system-covariance matrices. These are the output covariance **YY**, the measurement covariance **ZZ**, the control covariance **UU**, the estimated output covariance **YYEST**, and the estimated measurement covariance **ZZEST**.

The subroutine statement for COVM is as follows:

```
SUBROUTINE COVM (AA, BB, HH, CC, QQ, PP, KC, N, M, C, R, XX, YY, ZZ,
                UU, YYEST, ZZEST, KSIM, A, Q, BSIMQ, ASI, NMAX,
                MMAX, CMAX, RMAX, KSIMAX)
```

The input variables are

AA(N, N)	system matrix
BB(N, C)	control input matrix
HH(M, N)	measurement matrix
CC(R, N)	output matrix
QQ(N, N)	power spectral density matrix of plant disturbance
PP(N, N)	estimation error-covariance matrix
KC(C, N)	control-gain matrix

The input integer dimensions are

N	number of state variables
M	number of measurements
C	number of control inputs
R	number of outputs
KSIM	$(N \times N + N)/2$
NMAX	dimension, greater than or equal to N
MMAX	dimension, greater than or equal to M
CMAX	dimension, greater than or equal to C
RMAX	dimension, greater than or equal to R
KSIMAX	dimension, greater than or equal to KSIM

The output variables are

XX(N, N) state-covariance matrix
YY(R, R) output-covariance matrix
ZZ(M, M) measurement-covariance matrix
UU(C, C) control-covariance matrix
YYEST(R, R) estimated output-covariance matrix
ZZEST(M, M) estimated measurement-covariance matrix

The intermediate variables are

A(N, N) Lyapunov equation matrix
Q(N, N) Lyapunov equation matrix

The temporary storage arrays are

BSIMQ(KSIM)
ASI(KSIM, KSIM)

There are no error messages output from this subroutine. It prints the message

```

*****
                COVARIANCE MATRICES
*****
  
```

and then prints these arrays with the following headings:

UU, CONTROL COVARIANCE MATRIX
XX, STATE COVARIANCE MATRIX
YY, OUTPUT COVARIANCE MATRIX
YYEST, ESTIMATED OUTPUT COVARIANCE MATRIX
ZZ, MEASUREMENT COVARIANCE MATRIX
ZZEST, ESTIMATED MEASUREMENT COVARIANCE MATRIX

The mean-square state equation for the system obtained as the solution to the infinite-time LSOCE problem is given as equation (17). Subroutine COVM sets up the matrices $(A - BK_c)$ and $(BK_c P + PK_c^T B^T + Q)$ and calls subroutine LYPNV with these matrices, obtaining state-covariance matrix X . Then the various covariances are calculated.

Listing of Subroutine COVM

```

SUBROUTINE COVM (AA, BB, HH, CC, QQ, PP, KC, N, M, C, R, XX, YY, ZZ, UU, YYEST,
  ZZEST, KSIM, A, Q, BSIMQ, ASI, NMAX, MMAX, CMAX, RMAX, KSIMAX)
  
```

C

```

C *****
C COVM SETS UP MATRICES FOR SUBROUTINE LYPNV (LYAPUNOV EQ.)
C WHICH IS THEN CALLED TO OBTAIN STATE COVARIANCE MATRIX XX.
C XX, ESTIMATION ERROR COVARIANCE PP, AND CONTROL GAINS KC ARE
C USED TO OBTAIN VARIOUS OTHER SYSTEM COVARIANCE MATRICES
C *****
C
C DOUBLE PRECISION SUM1, SUM2
C INTEGER C, R, CMAX, RMAX
C REAL KC
C
C DIMENSION AA(NMAX,1), BB(NMAX,1), HH(MMAX,1), CC(RMAX,1),
C 1QQ(NMAX,1), PP(NMAX,1), KC(CMAX,1), XX(NMAX,1), YY(RMAX,1),
C 2ZZ(MMAX,1), UU(CMAX,1), YYEST(RMAX,1), ZZEST(MMAX,1), A(NMAX,1),
C 3Q(NMAX,1), BSIMQ(1), ASI(KSIMAX,1)
C
C WRITE (6,260)
C
C FORM COEFFICIENT MATRICES FOR LYAPUNOV EQUATION WHOSE SOLUTION
C IS STATE COVARIANCE MATRIX
C
C DO 20 J=1,N
C DO 20 I=1,N
C SUM1=AA(I,J)
C SUM2=QQ(I,J)
C DO 10 K=1,C
C SUM1=SUM1-BB(I,K)*KC(K,J)
C DO 10 L=1,N
C SUM2=SUM2+BB(I,K)*KC(K,L)*PP(L,J)+PP(I,L)*KC(K,L)*BB(J,K)
10 A(I,J)=SUM1
20 Q(I,J)=SUM2
C
C OBTAIN STATE COVARIANCE MATRIX AND STORE IN XX
C
C CALL LYPNV (A,Q,XX,ASI,BSIMQ,N,KSIM,NMAX,KSIMAX)
C
C OBTAIN COVARIANCE MATRICES FOR VARIABLES U(CONTROL),
C Z(MEASUREMENT), Y(OUTPUT), PLUS Z ESTIMATED AND Y ESTIMATED
C
C DO 40 J=1,R
C DO 40 I=1,R
C SUM1=0.000
C SUM2=0.000
C DO 30 L=1,N
C DO 30 K=1,N
C SUM1=SUM1+CC(I,K)*XX(K,L)*CC(J,L)
30 SUM2=SUM2+CC(I,K)*PP(K,L)*CC(J,L)
C YY(I,J)=SUM1
40 YYEST(I,J)=SUM2
C DO 60 J=1,M
C DO 60 I=1,M
C SUM1=0.000
C SUM2=0.000
C DO 50 L=1,N
C DO 50 K=1,N
C SUM1=SUM1+HH(I,K)*XX(K,L)*HH(J,L)
50 SUM2=SUM2+HH(I,K)*PP(K,L)*HH(J,L)
C ZZ(I,J)=SUM1
60 ZZEST(I,J)=SUM2
C DO 80 J=1,C

```



```

      DC 80 I=1,C
      SUM1=0.000
      DO 70 L=1,N
      DO 70 K=1,N
70     SUM1=SUM1+KC(I,K)*(XX(K,L)-PP(K,L))*KC(J,L)
80     UU(I,J)=SUM1
      WRITE (6,270)
      LL=1
      LLL=10
90     IF (C.LT.LLL) LLL=C
      DO 100 I=1,C
      WRITE (6,280) (UU(I,L),L=LL,LLL)
100    CONTINUE
      WRITE (6,290)
      IF (C.EQ.LLL) GO TO 110
      LL=LL+10
      LLL=LLL+10
      GO TO 90
110   WRITE (6,300)
      LL=1
      LLL=10
120   IF (N.LT.LLL) LLL=N
      DO 130 I=1,N
      WRITE (6,280) (XX(I,L),L=LL,LLL)
130   CONTINUE
      WRITE (6,290)
      IF (N.EQ.LLL) GO TO 140
      LL=LL+10
      LLL=LLL+10
      GO TO 120
140   WRITE (6,310)
      LL=1
      LLL=10
150   IF (R.LT.LLL) LLL=R
      DO 160 I=1,R
      WRITE (6,280) (YY(I,L),L=LL,LLL)
160   CONTINUE
      WRITE (6,290)
      IF (R.EQ.LLL) GO TO 170
      LL=LL+10
      LLL=LLL+10
      GO TO 150
170   WRITE (6,320)
      LL=1
      LLL=10
180   IF (R.LT.LLL) LLL=R
      DO 190 I=1,R
      WRITE (6,280) (YYEST(I,L),L=LL,LLL)
190   CONTINUE
      WRITE (6,290)
      IF (R.EQ.LLL) GO TO 200
      LL=LL+10
      LLL=LLL+10
      GO TO 180
200   WRITE (6,330)
      LL=1
      LLL=10
210   IF (M.LT.LLL) LLL=M
      DO 220 I=1,M
      WRITE (6,280) (ZZ(I,L),L=LL,LLL)

```

```

220  CONTINUE
      WRITE (6,290)
      IF (M.EQ.LLL) GO TO 230
      LL=LL+10
      LLL=LLL+10
      GO TO 210
230  WRITE (6,340)
      LL=1
      LLL=10
240  IF (M.LT.LLL) LLL=M
      DO 250 I=1,M
      WRITE (6,280) (ZZEST(I,L),L=LL,LLL)
250  CONTINUE
      WRITE (6,290)
      IF (M.EQ.LLL) RETURN
      LL=LL+10
      LLL=LLL+10
      GO TO 240
C
260  FORMAT (1H1/1X,50H*****
1**/15X,19HCOVARIANCE MATRICES/1X,50H*****
2*****//)
270  FORMAT (1X,29HUU, CONTROL COVARIANCE MATRIX)
280  FORMAT (1X,1P10E12.4)
290  FORMAT (1H0)
300  FORMAT (//1X,27HXX, STATE COVARIANCE MATRIX)
310  FORMAT (//1X,28HY, OUTPUT COVARIANCE MATRIX)
320  FORMAT (//1X,41HYEST, ESTIMATED OUTPUT COVARIANCE MATRIX)
330  FORMAT (//1X,33HZZ, MEASUREMENT COVARIANCE MATRIX)
340  FORMAT (//1X,46HZZEST, ESTIMATED MEASUREMENT COVARIANCE MATRIX)
      END

```

Description of Subroutine LYPNV

Subroutine LYPNV solves the Lyapunov equation. It first converts this equation, $A_L X_L + X_L A_L^T + Q_L = 0$, to a set of linear equations. Subroutine LYPNV then calls IBM SSP subroutine SIMQ (solves a set of linear, algebraic equations) to solve this equation set for the matrix X_L , called XX in the subroutine (ref. 13). Subroutine LYPNV also calls IBM SSP subroutine ARRAY.

The subroutine statement for LYPNV is as follows:

```
SUBROUTINE LYPNV (A,Q,XX,ASI,BSIMQ,N,KSIM,NMAX,KSIMAX)
```

The input variables are

A(N,N) Lyapunov equation matrix
Q(N,N) Lyapunov equation matrix

The input integer dimensions are

N dimension of A, Q, and XX
KSIM (N×N + N)/2

NMAX dimension, greater than or equal to N
 KSIMAX dimension, greater than or equal to KSIM

The output variable is

XX(N,N) output matrix

The temporary storage arrays are

ASI(KSIM, KSIM)

BSIMQ(KSIM)

There is one error message output from this subroutine. If IBM SSP subroutine SIMQ finds that the matrix of the equation set being solved is singular and cannot complete its calculations, subroutine LYPNV prints the following message:

MATRIX IS SINGULAR

There is no other printed output from this subroutine.

Listing of Subroutine LYPNV

```

SUBROUTINE LYPNV (A,Q,XX,ASI,BSIMQ,N,KSIM,NMAX,KSIMAX)
C
C *****
C LYAPUNOV EQUATION
C
C  $A * X + X * A^{**}T + Q = 0$ 
C
C LYPNV CONVERTS LYAPUNOV EQ. TO SET OF LINEAR EQUATIONS. LYPNV
C CALLS IBM SSP SUBROUTINES SIMQ (SOLVES EQUATION SET) AND ARRAY.
C  $KSIM = (N * N + N) / 2$ 
C FORM KSIM BY KSIM LHS MATRIX AND KSIM ORDER RHS VECTOR USING
C INPUT MATRICES A AND Q.
C *****
C
C DIMENSION A(NMAX,1), Q(NMAX,1), XX(NMAX,1), ASI(KSIMAX,1),
1 BSIMQ(1)
C
C DO 10 J=1,KSIM
  BSIMQ(J)=0.0
  DO 10 I=1,KSIM
    ASI(I,J)=0.0
10 CONTINUE
  JS=0
  DO 90 JJ=1,N
    DO 90 II=JJ,N
      JS=JS+1
      IF (II.NE.JJ) GO TO 20
      BSIMQ(JS)=-Q(II,JJ)
      GO TO 30
20 BSIMQ(JS)=- (Q(II,JJ)+Q(JJ,II))
30 CONTINUE

```

```

IS=0
DO 90 J=1,N
DO 90 I=J,N
IS=IS+1
IF (I.EQ.II) GO TO 40
IF (J.EQ.JJ) GO TO 50
IF (J.EQ.II) GO TO 60
IF (I.EQ.JJ) GO TO 70
GO TO 90
40 IF (J.NE.JJ.OR.J.EQ.II) GO TO 80
   ASI(IS,JS)=A(J,JJ)+A(I,II)
   GO TO 90
50 ASI(IS,JS)=A(I,II)
   GO TO 90
60 ASI(IS,JS)=A(I,JJ)
   GO TO 90
70 ASI(IS,JS)=A(J,II)
   GO TO 90
80 ASI(IS,JS)=A(J,JJ)
90 CONTINUE
DO 100 J=1,KSIM
DO 100 I=1,KSIM
100 ASI(I,J)=ASI(I,J)*2.0
C
C   SOLVE SET OF LINEAR EQS. VIA SIMQ
C
CALL ARRAY (2,KSIM,KSIM,KSIMAX,KSIMAX,ASI,ASI)
CALL SIMQ (ASI,BSIMQ,KSIM,KS)
CALL ARRAY (1,KSIM,KSIM,KSIMAX,KSIMAX,ASI,ASI)
IF (KS.EQ.1) WRITE (6,130)
JJJ=0
C
C   STORE SOLUTION IN SYMMETRIC MATRIX XX
C
DO 120 J=1,N
DO 120 I=1,N
IF (I.LT.J) GO TO 120
JJJ=JJJ+1
IF (I.NE.J) GO TO 110
XX(I,J)=BSIMQ(JJJ)
GO TO 120
110 XX(I,J)=BSIMQ(JJJ)
    XX(J,I)=BSIMQ(JJJ)
120 CONTINUE
RETURN
C
130 FORMAT (1X,18HMATRIX IS SINGULAR)
END

```

Description of Subroutine TRICCS

Subroutine TRICCS is used to compute the solution to the constant-coefficient matrix Riccati differential equation at NTAU time points, DT apart. A call to subroutine RICSS (providing the modified eigenvector matrix TT of the Hamiltonian matrix and the real and imaginary parts CR and CI of the eigenvalues of the Hamiltonian matrix)

must precede the call to subroutine TRICCS. That is, subroutine TRICCS requires that the results of the algebraic Riccati equation be available for use in solving for the transient (see the section Description of Subroutine RICSS). The initial (or terminal) condition matrix is specified as INIT, and the Riccati solution matrix appears as ANS. The gains are also calculated at each time point, either the KE's or the KC's depending on whether the transient is being calculated for the estimate or control problem. Subroutine TRICCS calls subroutine BDSTM and the IBM SSP subroutines ARRAY and MINV.

The subroutine statement for TRICCS is as follows:

```
SUBROUTINE TRICCS (TT,INIT,CR,CI,ANS,DT,NTAU,N,C,M,NE,
                  EX1,EX2,EX3,EX4,EX5,EX6,IPEP,IPERN,
                  HH,RRINV,NN,PCINV,BB,IEC,NMAX,CMAX,
                  MMAX,NEMAX)
```

The input variables are

TT(NE, NE)	modified eigenvector matrix (called X in subroutine RICSS)
CR(NE)	real parts of ordered eigenvalues (called CR in subroutine RICSS)
CI(NE)	imaginary parts of ordered eigenvalues (called CI in subroutine RICSS)
INIT(N, N)	initial condition of Riccati solution
HH(M, N)	measurement matrix
RRINV(M, M)	inverse of power spectral density matrix of measurement noise
NN(N, C)	state-control product weighting matrix
PCINV(C, C)	inverse of control weighting matrix
BB(N, C)	control input matrix
IEC	switch (1, if call is for estimate; 2, if call is for control)
NTAU	number of time points
DT	time step

The input integer dimensions are

N	order of Riccati equation
C	number of control inputs
M	number of measurements
NE	2×N

NMAX dimension, greater than or equal to N
 CMAX dimension, greater than or equal to C
 MMAX dimension, greater than or equal to M
 NEMAX dimension, greater than or equal to NE

The output variable is

ANS(N, N) solution to Riccati equation

The temporary storage arrays are

EX1(N, N)

EX2(N, N)

EX3(N, N)

EX4(N, N)

EX5(N)

EX6(N)

IPER(N) integer

IPERN(N) integer

There are two error messages from subroutine TRICCS. During the inversion of ANS the following message may be printed:

ANS IS SINGULAR

And during the inversion of EX1 the following message may be printed:

EX1 IS SINGULAR

The normal output from subroutine TRICCS is the message

```
*****
          TRANSIENT RICCATI SOLUTION
*****
```

It then prints the time with the heading

TIME =

followed by the ANS array with the heading

RICCATI SOLUTION MATRIX

followed by either the estimate gains or the control gains (depending on the call) with one of these headings:

KE, THE TRANSIENT ESTIMATE GAIN MATRIX

or

KC, THE TRANSIENT CONTROL GAIN MATRIX

There will be a series of these outputs, one set for each time point calculated.

The method used by subroutine TRICCS, given in reference 6, is as follows: Subroutine TRICCS computes the $n \times n$, positive-definite, symmetric solution matrix for the matrix Riccati differential equation

$$\dot{V} = -VM_{11} - M_{11}^T V - VM_{12}V + M_{21} \quad (60)$$

with the initial condition, $V(0) = V_0$, and where the $2n \times 2n$ Hamiltonian matrix M is defined as

$$M = \begin{bmatrix} M_{11} & M_{12} \\ M_{21} & M_{22} \end{bmatrix} \quad (61)$$

and $M_{22} = -M_{11}^T$. Subroutine TRICCS uses the results of subroutine RICSS, namely, eigenvalues and modified eigenvectors of M , plus the matrix exponential subroutine BDSTM, in computing its results. The method used follows that of Vaughan (ref. 6), except that where Vaughan used complex eigenvalues and eigenvectors involving complex arithmetic, this algorithm requires only real arithmetic. Since the modified-eigenvector-method matrix T and the block-diagonal-system matrix \bar{C} (see the section Description of Subroutine RICSS) are used, the basic equation solved by subroutine TRICCS is

$$V(k \Delta t) = \begin{bmatrix} T_{21} & -T_{22}W(k \Delta t) \end{bmatrix} \begin{bmatrix} T_{11} & -T_{12}W(k \Delta t) \end{bmatrix}^{-1} \quad (62)$$

where

$$W(k \Delta t) = \exp(\bar{C}k \Delta t) \begin{bmatrix} V_0 T_{12} & -T_{22} \end{bmatrix}^{-1} \begin{bmatrix} V_0 T_{11} & -T_{21} \end{bmatrix} \left[\exp(\bar{C}k \Delta t) \right]^T \quad (63)$$

Here, Δt is the time step, k is an integer, $k \Delta t$ is the time at which V is to be calculated. Matrices \bar{C} and T_{ij} are defined in the section Description of Subroutine RICSS. The state transition matrix $\exp(\bar{C} \Delta t)$ is calculated by using subroutine BDSTM, and then $\exp(\bar{C}k \Delta t)$ is calculated as

$$\exp(\bar{C}k \Delta t) = \exp[\bar{C}(k-1)\Delta t] \times \exp(\bar{C} \Delta t) \quad (64)$$

Depending on whether IEC is 1 or 2, subroutine TRICCS computes K_e or K_c , using equation (9) or (11).

Listing of Subroutine TRICCS

SUBROUTINE TRICCS (TT,INIT,CR,CI,ANS,DT,NTAU,N,C,M,NE,EX1,EX2,EX3,
1EX4,EX5,EX6,IPER,IPERN,HH,RRINV,NN,PCINV,BB,IEC,NMAX,CMAX,MMAX,
2NEMAX)

```

C
C *****
C TRICCS COMPUTES THE SOLUTION TO THE RICCATI DIFFERENTIAL EQUATION
C AT NTAU TIME POINTS, DT APART, AND A TRANSIENT GAIN AT EACH POINT.
C TRICCS CALLS SUBROUTINE BDSTM AND IBM SSP SUBROUTINES MINV AND
C ARRAY.
C *****
C
REAL INIT, NN
INTEGER C, CMAX
DOUBLE PRECISION SUM, SUM1

C
DIMENSION TT(NEMAX,1), INIT(NMAX,1), CR(1), CI(1), ANS(NMAX,1),
1EX1(NMAX,1), EX2(NMAX,1), EX3(NMAX,1), EX4(NMAX,1), EX5(1),
2EX6(1), IPER(1), IPERN(1), HH(MMAX,1), RRINV(MMAX,1), NN(NMAX,1),
3PCINV(CMAX,1), BB(NMAX,1)

C
ANTAU=NTAU
XTIME=ANTAU*DT
WRITE (6,360)
IF (IEC.EQ.1) TIME=0.0
IF (IEC.EQ.2) TIME=XTIME
WRITE (6,370) TIME
WRITE (6,380)
LL=1
LLL=10
10 IF (N.LT.LLL) LLL=N
DO 20 I=1,N
WRITE (6,390) (INIT(I,L),L=LL,LLL)
20 CONTINUE
WRITE (6,400)
IF (N.EQ.LLL) GO TO 30
LL=LL+10
LLL=LLL+10
30 DO 50 J=1,N
JJ=J+N
DO 50 I=1,N
SUM=0.000
SUM1=0.000
DO 40 K=1,N
SUM=SUM+INIT(I,K)*TT(K,JJ)
40 SUM1=SUM1+INIT(I,K)*TT(K,J)
ANS(I,J)=SUM
EX1(I,J)=SUM1
DO 60 J=1,N
JJ=J+N
DO 60 I=1,N
II=I+N
SUM=0.000
SUM1=0.000
SUM=ANS(I,J)-TT(II,JJ)

```



```

SUM1=EX1(I,J)-TT(II,J)
ANS(I,J)=SUM
60 EX1(I,J)=SUM1
CALL ARRAY (2,N,N,NMAX,NMAX,ANS,ANS)
CALL MINV (ANS,N,DET,IPER,IPERN)
CALL ARRAY (1,N,N,NMAX,NMAX,ANS,ANS)
IF (DET.EQ.0.0) WRITE (6,410)
DO 80 J=1,N
DO 80 I=1,N
SUM=C.000
DO 70 K=1,N
70 SUM=SUM+ANS(I,K)*EX1(K,J)
80 INIT(I,J)=SUM
DO 90 I=1,N
EX6(I)=-CR(I)
90 EX5(I)=CI(I)
CALL BDSTM (DT,EX6,EX5,EX4,N,NMAX)
DO 100 J=1,N
DO 100 I=1,N
100 EX3(I,J)=EX4(I,J)
DO 350 ITIME=1,NTAU
ATIME=ITIME
TIME=DT*ATIME
IF (IEC.EQ.1) GO TO 110
TIME=XTIME-TIME
110 WRITE (6,370) TIME
WRITE (6,380)
IF (ITIME.EQ.1) GO TO 150
DO 130 J=1,N
DO 130 I=1,N
SUM=C.000
DO 120 K=1,N
120 SUM=SUM+EX3(I,K)*EX4(K,J)
130 EX2(I,J)=SUM
C IF STM VALUES .LT. 1.0E-15, SET TO 0.0
DO 140 J=1,N
DO 140 I=1,N
IF (ABS(EX2(I,J)).LE.1.0E-15) EX2(I,J)=0.0
140 EX3(I,J)=EX2(I,J)
150 CONTINUE
C EX3 NOW CONTAINS THE BLOCK DIAGONAL STATE TRANSITION MATRIX
DO 170 J=1,N
DO 170 I=1,N
SUM=C.000
DO 160 L=1,N
DO 160 K=1,N
160 SUM=SUM+EX3(I,K)*INIT(K,L)*EX3(J,L)
170 ANS(I,J)=SUM
DO 190 J=1,N
JJ=J+N
DO 190 I=1,N
II=I+N
SUM=C.000
SUM1=0.000
DO 180 K=1,N
KK=K+N
SUM=SUM+TT(I,KK)*ANS(K,J)
180 SUM1=SUM1+TT(II,KK)*ANS(K,J)
EX1(I,J)=SUM

```

```

190  EX2(I,J)=SUM1
      DO 200 J=1,N
      DO 200 I=1,N
      II=I+N
      SUM=-EX1(I,J)+TT(I,J)
      SUM1=-EX2(I,J)+TT(II,J)
      EX1(I,J)=SUM
200  EX2(I,J)=SUM1
      CALL ARRAY (2,N,N,NMAX,NMAX,EX1,EX1)
      CALL MINV (EX1,N,DET,IPER,IPERN)
      CALL ARRAY (1,N,N,NMAX,NMAX,EX1,EX1)
      IF (DET.EQ.0.0) WRITE (6,420)
      DO 220 J=1,N
      DO 220 I=1,N
      SUM=0.000
      DO 210 K=1,N
210  SUM=SUM+EX2(I,K)*EX1(K,J)
220  ANS(I,J)=SUM
      LL=1
      LLL=10
230  IF (N.LT.LLL) LLL=N
      DO 240 I=1,N
      WRITE (6,390) (ANS(I,L),L=LL,LLL)
240  CONTINUE
      WRITE (6,400)
      IF (N.EQ.LLL) GO TO 250
      LL=LL+10
      LLL=LLL+10
      GO TO 230
250  IF (IEC.NE.1) GO TO 300
      DO 270 J=1,M
      DO 270 I=1,N
      SUM=0.000
      DO 260 L=1,M
      DO 260 K=1,N
260  SUM=SUM+ANS(I,K)*HH(L,K)*RRINV(L,J)
270  EX2(I,J)=SUM
      WRITE (6,430)
      LL=1
      LLL=10
280  IF (M.LT.LLL) LLL=M
      DO 290 I=1,N
      WRITE (6,390) (EX2(I,L),L=LL,LLL)
290  CONTINUE
      WRITE (6,400)
      IF (M.EQ.LLL) GO TO 300
      LL=LL+10
      LLL=LLL+10
      GO TO 280
300  IF (IEC.NE.2) GO TO 350
      DO 320 J=1,N
      DO 320 I=1,C
      SUM=0.000
      DO 310 K=1,C
      SUM=SUM+PCINV(I,K)*NN(J,K)
      DO 310 L=1,N
310  SUM=SUM+PCINV(I,K)*BB(L,K)*ANS(L,J)
320  EX2(I,J)=SUM
      WRITE (6,440)

```

```

LL=1
LLL=10
330 IF (N.LT.LLL) LLL=N
DO 340 I=1,C
WRITE (6,390) (EX2(I,L),L=LL,LLL)
340 CONTINUE
WRITE (6,400)
IF (N.EQ.LLL) GO TO 350
LL=LL+10
LLL=LLL+10
GO TO 330
350 CONTINUE
RETURN
C
360 FORMAT (1H1/1X,50H*****
1**/15X,26HTRANSIENT RICCATI SOLUTION/1X,50H*****
2*****//)
370 FORMAT (/40X,7HTIME = ,E12.5)
380 FORMAT (/30X,23HRICCATI SOLUTION MATRIX)
390 FORMAT (1X,1P10E12.4)
400 FORMAT (1H0)
410 FORMAT (1X,15HANS IS SINGULAR)
420 FORMAT (1X,15HEX1 IS SINGULAR)
430 FORMAT (1X,38HKE, THE TRANSIENT ESTIMATE GAIN MATRIX)
440 FORMAT (1X,37HKC, THE TRANSIENT CONTROL GAIN MATRIX)
END

```

Description of Subroutine BDSTM

Subroutine BDSTM computes the state transition matrix for a matrix in block-diagonal form. The matrix's eigenvalues are the subroutine's inputs.

The subroutine statement for BDSTM is as follows:

```
SUBROUTINE BDSTM (DT,CR,CI,EAT,N,NMAX)
```

The input variables are

DT	time step
CR(N)	real parts of eigenvalues
CI(N)	imaginary parts of eigenvalues

The input integer dimensions are

N	matrix size
NMAX	dimension, greater than or equal to N

The output variable is

EAT(N,N)	block-diagonal state transition matrix
----------	--

Subroutine BDSTM prints no error messages and no output.

The method used by subroutine BDSTM is as follows: given an $n \times n$ matrix A having eigenvalues $\lambda = \alpha_i + j\beta_i$ ($i = 1, 2, \dots, n$), \tilde{A} , the block-diagonal form of A , can be displayed as

$$\tilde{A} = \begin{bmatrix} \alpha_{k-1} & & 0 \\ & \tilde{B} & \\ 0 & & \alpha_{k+2} \end{bmatrix} \quad (65)$$

where

$$\tilde{B} = \begin{bmatrix} \alpha_k & \beta_k \\ \beta_{k+1} & \alpha_{k+1} \end{bmatrix} \quad (66)$$

Shown here are how two real (α_{k-1} and α_{k+2}) eigenvalue coefficients and the coefficients of a typical complex conjugate pair ($\alpha_k + j\beta_k$ and $\alpha_{k+1} + j\beta_{k+1}$) are placed on the diagonal of \tilde{A} , either singly, or as a 2×2 block, \tilde{B} . Note that for the complex conjugate pair, $\alpha_k = \alpha_{k+1}$ and $\beta_{k+1} = -\beta_k$. Subroutine BDSTM assumes that the vectors (CR and CI) of the eigenvalues are such that a conjugate pair is stored in successive locations. This will be the case if subroutine EIGQR is used to find the eigenvalues.

We desire to find the state transition matrix $\exp(\tilde{A} \Delta t)$, where Δt is the desired time interval. It can be displayed as

$$\exp(\tilde{A} \Delta t) = \begin{bmatrix} \exp(\alpha_{k-1} \Delta t) & & 0 \\ & \exp(\tilde{B} \Delta t) & \\ 0 & & \exp(\alpha_{k+2} \Delta t) \end{bmatrix} \quad (67)$$

where $\exp(\tilde{B} \Delta t)$ is a 2×2 matrix,

$$\exp(\tilde{B} \Delta t) = \begin{bmatrix} \exp(\alpha_k \Delta t) \times \cos(\beta_k \Delta t) & -\exp(\alpha_k \Delta t) \times \sin(\beta_k \Delta t) \\ \exp(\alpha_k \Delta t) \times \sin(\beta_k \Delta t) & \exp(\alpha_k \Delta t) \times \cos(\beta_k \Delta t) \end{bmatrix} \quad (68)$$

In order to see that $\exp(\tilde{B} \Delta t)$ is in fact of this form, consider the 2×2 diagonal matrix,

$$B = \begin{bmatrix} \alpha + j\beta & 0 \\ 0 & \alpha - j\beta \end{bmatrix} \quad (69)$$

where the diagonal elements are conjugates. Then for a transformation matrix U given as

$$U = \begin{bmatrix} 1 - j & 1 + j \\ 1 + j & 1 - j \end{bmatrix} \quad (70)$$

it can be shown that $U^{-1}BU = \tilde{B}$. Thus,

$$\exp(\tilde{B} \Delta t) = \exp(U^{-1}B \Delta t U) \quad (71)$$

or

$$\begin{aligned} \exp(\tilde{B} \Delta t) &= U^{-1} \exp(B \Delta t) U \\ &= U^{-1} \begin{bmatrix} \exp(\alpha + j\beta)\Delta t & 0 \\ 0 & \exp(\alpha - j\beta)\Delta t \end{bmatrix} U \\ &= U^{-1} \begin{bmatrix} \exp(\alpha \Delta t) \times [\cos(\beta \Delta t) + j \sin(\beta \Delta t)] & 0 \\ 0 & \exp(\alpha \Delta t) \times [\cos(\beta \Delta t) - j \sin(\beta \Delta t)] \end{bmatrix} U \\ &= \begin{bmatrix} \exp(\alpha \Delta t) \cos(\beta \Delta t) & -\exp(\alpha \Delta t) \sin(\beta \Delta t) \\ \exp(\alpha \Delta t) \sin(\beta \Delta t) & \exp(\alpha \Delta t) \cos(\beta \Delta t) \end{bmatrix} \end{aligned} \quad (72)$$

EIGQR prints **THE FOLLOWING ANSWER(S) DID NOT CONVERGE**
if an eigenvalue or eigenvalue pair cannot be found in 50 iterations. The program then continues to the next eigenvalue iteration.

ORDER prints **EIGENVALUES ARE NOT SYMMETRIC**
if an eigenvalue pair is not symmetric within the EPS criterion. The program then stops.

EGVCTR prints **FACTR IS WRONG**
if the matrix for a real eigenvector cannot be factored into upper and lower triangular segments by IBM SSP subroutine FACTR. The program then continues.

EGVCTR prints **FACTR 2 IS WRONG**
if the matrix for a complex eigenvector cannot be factored into upper and lower triangular segments by IBM SSP subroutine FACTR. The program then continues.

CONCLUDING REMARKS

This report has presented a program for solving the LSOCE problem. Options that allow solution of all or part of the problem have been included. The LSOCE program has been used for systems as large as 10th order on an IBM 7090-7094 computer with a DCS system. For these cases, the program used reasonable amounts of time and storage. A similar version of the LSOCE program has been run on an IBM 360-67 computer for problems as large as 41st order, with good results. Certain of the subroutines used in LSOCE, such as those for reducing and scaling a matrix, for obtaining eigenvectors and eigenvalues, and for solving the Lyapunov equation, have been made general enough so as to be useful by themselves in the analysis of dynamic systems.

Lewis Research Center,
National Aeronautics and Space Administration,
Cleveland, Ohio, September 3, 1974,
501-24.

APPENDIX A

SYMBOLS

Mathematical symbol	FORTTRAN symbol	Description
A	AA	system matrix, $n \times n$
A		general matrix, $n \times n$
\tilde{A}		block-diagonal form of A, $n \times n$
A_L	A	Lyapunov equation matrix, $n \times n$
B	BB	control input matrix, $n \times c$
B		diagonal matrix, 2×2
B		Boolean matrix, $n \times n$
\tilde{B}		diagonal block matrix, 2×2
b		right-hand-side vector, $n \times 1$
C	CC	output matrix, $r \times n$
C		intermediate matrix in complex eigenvector computation, $n \times n$
C		upper diagonal submatrix of Λ , $n \times n$
\bar{C}		lower diagonal submatrix of Λ , $n \times n$
c	C	integer, number of control inputs
D		intermediate matrix in eigenvector computation, $n \times n$
H	HH	measurement matrix, $m \times n$
I		identity matrix, $n \times n$
J		performance index for LSOCE problem
J^*		performance index for infinite-time LSOCE problem
j		$\sqrt{-1}$
K_c	KC	control-gain matrix, $c \times n$
K_e	KE	estimator-gain matrix, $n \times m$
k		integer index
L		lower triangular matrix, $n \times n$

Mathematical symbol	FORTRAN symbol	Description
M	AAA	Hamiltonian matrix, $2n \times 2n$
m	M	integer, number of measurements
N	NN	state-control product weighting matrix, $n \times c$
n	N	integer, number of states
n		integer, dimension of a general matrix
P	PP	estimation-error covariance matrix, $n \times n$
P		permutation matrix, $n \times n$
P_c^{-1}	PCINV	inverse of control weighting matrix, $c \times c$
Q	QQ	power spectral density matrix of plant disturbance, $n \times n$
Q_c	QC	state weighting matrix, $n \times n$
Q_L	Q	Lyapunov equation matrix, $n \times n$
q		eigenvector, $n \times 1$
R^{-1}	RRINV	inverse of power spectral density matrix of measurement noise, $m \times m$
r	R	integer, number of outputs
S	SS	control matrix Riccati solution, $n \times n$
T	X	modified eigenvector matrix of a Hamiltonian matrix, $2n \times 2n$
T		modified eigenvector matrix of a general matrix, $n \times n$
t		time
Δt		time step
U	UU	control-covariance matrix, $c \times c$
U		transformation matrix, 2×2
U		upper triangular matrix, $n \times n$
u		control vector, $c \times 1$
V	ANS	Riccati solution matrix, $n \times n$
v		white, zero-mean, Gaussian, measurement-noise vector, $m \times 1$
W		intermediate matrix for transient Riccati solution, $n \times n$

Mathematical symbol	FORTRAN symbol	Description
w		white, zero-mean, Gaussian, plant-noise vector, $n \times 1$
X	XX	state-covariance matrix (symmetric), $n \times n$
\hat{X}		covariance of \hat{x} , $n \times n$
X_L		Lyapunov output matrix, $n \times n$
x		state vector, $n \times 1$
x		linear equation solution vector, $n \times 1$
\hat{x}		estimate of x, $n \times 1$
Y	YY	output-covariance matrix, $r \times r$
\hat{Y}	YYEST	estimated output-covariance matrix, $r \times r$
y		output vector, $r \times 1$
y		intermediate vector in eigenvector computation, $n \times 1$
\hat{y}		estimated output vector, $r \times 1$
Z	ZZ	measurement-covariance matrix, $m \times m$
\hat{Z}	ZZEST	estimated measurement-covariance matrix, $m \times m$
z		measurement vector, $m \times 1$
z		intermediate vector in eigenvector computation, $n \times 1$
\hat{z}		estimated measurement vector, $m \times 1$
α		real part of eigenvalue
β		imaginary part of eigenvalue
δ		Dirac delta function
ϵ	EPS	symmetry criterion
Λ		block-diagonal form of Hamiltonian matrix, $2n \times 2n$
λ		eigenvalue
τ		time
Subscripts:		
f		final value
max		element of complex vector having largest magnitude
R		real part of

Mathematical symbol	FORTRAN symbol	Description
I		imaginary part of
$\left. \begin{array}{l} i, j, k, \\ k-1, \\ k+1, \\ k+2, \\ 1, 2, 3 \end{array} \right\}$		integers, elements of
0		initial value
Superscripts:		
T		transpose
-1		matrix inverse
($\dot{\quad}$)		derivative with respect to time
i; i+1		value after i or (i + 1)th iteration
Operators:		
E[\quad]		expected value of
\quad		absolute value of
-		approaches, in the limit

APPENDIX B

SAMPLE PROBLEM

The main routine LSOCE and its related subroutines were used to run a sample problem for a 10th-order system ($N = 10$) having two inputs ($C = 2$), three outputs ($R = 3$), and four measurements ($M = 4$). The option used was ISORT = 4, which exercised all subroutines. The state variable description in terms of A, B, C, and H matrices is shown in the following table:

A

0.	1.	0.	0.	0.	0.	0.	0.	0.	0.
0.	0.	1.	0.	0.	0.	0.	0.	0.	0.
-.025	-.29	-.5	0.	0.	0.	0.	-17360.	-826.7	-8.267
.09	.3	1.	-1.	0.	0.	0.	0.	0.	0.
.09	.3	1.	0.	-5.	0.	0.	0.	0.	0.
0.	0.	0.	0.	0.	0.	1.	0.	0.	0.
0.	0.	0.	1.667	1.667	-100.	-12.	0.	0.	0.
0.	0.	0.	0.	0.	0.	0.	0.	1.	0.
0.	0.	0.	0.	0.	0.	0.	0.	0	1.
0.	0.	0.	0.	0.	500.	25.	-2.5E5	-1.05E4	-180.

C

0.	0.	0.	1.667	1.667	0.	0.	0.	0.	0.
0.	0.	0.	0.	0.	0.	0.	62500.	2976.	29.76
0.	0.	0.	0.	0.	500.	25.	0.	0.	0.

H

0.	0.	0.	1.667	1.667	0.	0.	0.	0.	0.
0.	0.	0.	0.	0.	0.	0.	62500.	2976.	29.76
0.	0.	0.	0.	0.	500.	25.	0.	0.	0.
.09	.3	1.	0.	0.	0.	0.	0.	0.	0.

B

0.	0.
0.	0.
.2778	0.
0.	0.
0.	0.
0.	0.
0.	1.
0.	0.
0.	0.
0.	0.

For the LSOCE problem, the following noise and weighting matrices were chosen:

$$\begin{aligned}
 Q &= \text{diag} (.1, .1, .1, .1, .1, .1, .1, .1, .001, .001, .001) \\
 R^{-1} &= \text{diag} (.01, .01, .01, .01) \\
 Q_c &= \text{diag} (1.0, 1.0, 1.0, 1.0, 1.0, 1.0, 1.0, 1.0, 1.0, 1.0) \\
 N &= 0 \\
 P_c^{-1} &= \text{diag} (1.0, 1.0)
 \end{aligned}$$

For computing the finite-time Kalman filter gains, the initial value of $P(t)$ was

$$P_0 = \text{diag} (1., 1., 1., 1., 1., 1., 1., 1., 1., 1.)$$

For computing the finite-time control gains, the terminal weighting $S(t)$ was

$$S_f = \text{diag} (1., 1., 1., 1., 1., 1., 1., 1., 1., 1.)$$

The time interval over which the performance index was minimized was chosen to be 12.0 seconds (that is, 60 time steps with $\Delta t = 0.2$). Transient results were calculated and printed each 0.2 second.

Both IOP1 and IOP2 were set to 1 to obtain full printout. The following is a listing of main routine LSOCE plus the program outputs:

```

C      MAIN PROGRAM
C
C      *****
C PLANT
C      XDOT = AA * X + BB * U + W
C MEASUREMENT
C      Z = H * X + V
C NOISE
C      COV(W) = QQ,      COV(V) = RR
C PERFORMANCE INDEX
C      J = E ( 1/2 * ( X**T * QC * X + X**T * NN * U + U**T * PC * U ) )
C
C      DIMENSIONS AND DESCRIPTIONS OF PROGRAM VARIABLES
C
C      A(N,N)          LYAPUNOV EQUATION MATRIX
C      AA(N,N)         SYSTEM MATRIX
C      AAA(2N,2N)      HAMILTONIAN MATRIX ASSOCIATED WITH THE
C                      RICCATI EQUATION
C      ANS(N,N)        RICCATI SOLUTION FROM TRICCS
C      BB(N,C)         CONTROL INPUT MATRIX
C      CC(P,N)         OUTPUT MATRIX
C      CI(2N)          EIGENVALUE IMAGINARY PARTS (OF AAA)
C      CR(2N)          EIGENVALUE REAL PARTS (OF AAA)
C      HH(M,N)         MEASUREMENT MATRIX
C      IDR(2N)         BLOCK DIAGONALIZING PERMUTATION VECTOR
C                      (INTEGER)
C      KC(C,N)         CONTROL GAIN MATRIX
C      KE(N,M)         ESTIMATOR GAIN MATRIX (REAL)
C      NBL(2N)         SIZE OF INDIVIDUAL IRREDUCIBLE BLOCKS
C                      (INTEGER)
C      NN(N,C)         STATE / CONTROL WEIGHTING MATRIX
C      PCINV(C,C)      INVERSE OF CONTROL WEIGHTING MATRIX
C      PP(N,N)         ESTIMATION ERROR COVARIANCE MATRIX

```

```

C      PPINIT(N,N)          INITIAL CONDITION OF RICCATI SOLUTION FOR
C                          TRANSIENT ESTIMATE PROBLEM
C      Q(N,N)              LYAPUNOV EQUATION MATRIX (SYMMETRIC)
C      QC(N,N)             STATE WEIGHTING MATRIX
C      QQ(N,N)            POWER SPECTRAL DENSITY MATRIX OF PLANT
C                          DISTURBANCE
C      RRINV(M,M)         INVERSE OF POWER SPECTRAL DENSITY MATRIX
C                          OF MEASUREMENT NOISE
C      SS(N,N)            CONTROL MATRIX RICCATI SOLUTION
C      SSINIT(N,N)       INITIAL CONDITION OF RICCATI SOLUTION FOR
C                          TRANSIENT CONTROL PROBLEM
C      TS(2N)            SCALING TRANSFORMATION
C      UU(C,C)           CONTROL COVARIANCE MATRIX
C      X(2N,2N)          MODIFIED EIGENVECTOR MATRIX (OF AAA)
C      XX(N,N)           STATE COVARIANCE MATRIX (SYMMETRIC)
C      YY(R,R)           OUTPUT COVARIANCE MATRIX
C      YYEST(R,R)        ESTIMATED OUTPUT COVARIANCE MATRIX
C      ZZ(M,M)           MEASUREMENT COVARIANCE MATRIX
C      ZZEST(M,M)        ESTIMATED MEASUREMENT COVARIANCE MATRIX

```

DIMENSIONS OF TEMPORARY STORAGE ARRAYS

```

C      AI(2N)
C      AR(2N)
C      ASI((N*N+N)/2,(N*N+N)/2)
C      BSIMQ((N*N+N)/2)
C      EXT(2N,2N)
C      EX1(N,N)
C      EX2(N,N)
C      EX3(N,N)
C      EX4(N,N)
C      EX5(N)
C      EX6(N)
C      IBL(2N)            INTEGER
C      IPER(2N)          INTEGER
C      IPERN(2N)         INTEGER
C      JMAX(2N)          INTEGER
C      TT(2N,2N)
C      XR(2N,2N)

```

```

C      DIMENSION AA(12,12), QQ(12,12), QC(12,12), PP(12,12), SS(12,12),
C      1XX(12,12), A(12,12), Q(12,12), ANS(12,12), EX1(12,12), EX2(12,12),
C      2EX3(12,12), EX4(12,12), PPINIT(12,12), SSINIT(12,12), AAA(24,24),
C      3TT(24,24), EXT(24,24), X(24,24), XR(24,24), ASI(78,78), YY(5,5),
C      4ZZ(5,5), UU(5,5), YYEST(5,5), ZZEST(5,5), RRINV(5,5), PCINV(5,5),
C      5BB(12,5), NN(12,5), KE(12,5), KC(5,12), CC(5,12), HH(5,12),
C      6EX5(12), EX6(12), TS(24), CR(24), CI(24), AR(24), AI(24),
C      7IPER(24), IPERN(24), BSIMQ(78), IOR(24), NBL(24), IBL(24),
C      8JMAX(24)
C      REAL KE, NN, KC
C      REAL INIT
C      INTEGER C, R, CMAX, RMAX

```

```

C      DATA ((AA(I,J), I = 1,10), J = 1,10)
C      1 / 2 * 0.0, -.025, 2 * .09, 5 * 0.0, 1.0, 0.0, -.29, 2 * .3,
C      2 6 * 0.0, 1.0, -.5, 2 * 1.0, 8 * 0.0, -1.0, 2 * 0.0, 1.667,
C      3 7 * 0.0, -5.0, 0.0, 1.667, 9 * 0.0, -100.0, 2 * 0.0, 500.0,

```

```

4 5 * 0.0, 1.0, -12.0, 2 * 0.0, 25.0, 2 * 0.0, -17360.0, 6 * 0.0,
5 -2.5E5, 2 * 0.0, -826.7, 4 * 0.0, 1.0, 0.0, -1.05E4, 2 * 0.0,
6 -8.267, 5 * 0.0, 1.0, -180.0 /
DATA ((BB(I,J), I = 1,10), J = 1,2)
1 / 2 * 0.0, .2778, 13 * 0.0, 1.0, 3 * 0.0 /
DATA ((HH(I,J), I = 1,4), J = 1,10)
1 / 3 * 0.0, .09, 3 * 0.0, .3, 3 * 0.0, 1.0, 1.667, 3 * 0.0, 1.667,
2 5 * 0.0, 500.0, 3 * 0.0, 25.0, 2 * 0.0, 62500.0, 3 * 0.0, 2976.0,
3 3 * 0.0, 29.76, 2 * 0.0 /
DATA ((QQ(I,J), I = 1,10), J = 1,10)
1 / 0.10, 10 * 0.0, 0.10, 10 * 0.0, 0.10, 10 * 0.0, 10 * 0.0, 0.10, 10 * 0.0,
2 0.10, 10 * 0.0, 0.10, 10 * 0.0, 0.10, 10 * 0.0, .001, 10 * 0.0,
3 .001, 10 * 0.0, .001 /
DATA ((RRINV(I,J), I = 1,4), J = 1,4)
1 / 1.0E-2, 4 * 0.0, 1.0E-2, 4 * 0.0, 1.0E-2, 4 * 0.0, 1.0E-2 /
DATA ((QC(I,J), I = 1,10), J = 1,10)
1 / 1.0, 10 * 0.0, 1.0, 10 * 0.0, 1.0, 10 * 0.0, 1.0, 10 * 0.0,
2 1.0, 10 * 0.0, 1.0, 10 * 0.0, 1.0, 10 * 0.0, 1.0, 10 * 0.0, 1.0,
3 10 * 0.0, 1.0 /
DATA ((NN(I,J), I = 1,10), J = 1,2)
1 / 20 * 0.0 /
DATA ((PCINV(I,J), I = 1,2), J = 1,2)
1 / 1.0, 2 * 0.0, 1.0 /
DATA ((CC(I,J), I = 1,3), J = 1,10)
1 / 9 * 0.0, 1.667, 2 * 0.0, 1.667, 4 * 0.0, 500.0, 2 * 0.0, 25.0,
2 0.0, 62500.0, 2 * 0.0, 2976.0, 2 * 0.0, 29.76, 0.0 /
DATA ((PPINIT(I,J), I = 1,10), J = 1,10)
1 / 1.0, 10 * 0.0, 1.0, 10 * 0.0, 1.0, 10 * 0.0, 1.0, 10 * 0.0,
2 1.0, 10 * 0.0, 1.0, 10 * 0.0, 1.0, 10 * 0.0, 1.0, 10 * 0.0, 1.0,
3 10 * 0.0, 1.0 /
DATA ((SSINIT(I,J), I = 1,10), J = 1,10)
1 / 1.0, 10 * 0.0, 1.0, 10 * 0.0, 1.0, 10 * 0.0, 1.0, 10 * 0.0,
2 1.0, 10 * 0.0, 1.0, 10 * 0.0, 1.0, 10 * 0.0, 1.0, 10 * 0.0, 1.0,
3 10 * 0.0, 1.0 /
DATA N / 10 /, M / 4 /, C / 2 /, R / 3 /, IOPL / 1 /, IOP2 / 1 /
DATA DT / .200 /, NTAU / 60 /, ISDRT / 4 /

```

C

```

NMAX = 12
MMAX = 5
CMAX = 5
RMAX = 5
N2MAX = NMAX + NMAX
KMAX = NMAX * NMAX
KSIMAX = (KMAX + NMAX) / 2
N2=N+N
K=N*N
KSIM=(K+N)/2

```

C

```
IF (ISORT.GT.5) GO TO 10
```

C

```
CALL ESTMAT (AA,HH,QQ,RRINV,KE,PP,CR,CI,X,TS,XR,TT,AAA,EXT,AR,AI,
IIPER,IPERN,IOR,NBL,IBL,JMAX,N,M,N2,IOPL,IOP2,NMAX,MMAX,N2MAX)
```

C

```
IF (ISORT.EQ.1) STOP
IF (ISORT.EQ.5) GO TO 10
```

C

```
CALL TRICCS (X,PPINIT,CR,CI,ANS,DT,NTAU,N,C,M,N2,EX1,EX2,EX3,EX4,
1EX5,EX6,IIPER,IPERN,HH,RRINV,NN,PCINV,BB,1,NMAX,CMAX,MMAX,N2MAX)
```

C

```

10  IF (ISORT.EQ.2) STOP
    IF (ISORT.EQ.9) GO TO 20
C
    CALL CONTRL (AA,BB,QC,NN,PCINV,KC,SS,CR,CI,X,TS,XR,TT,AAA,EXT,AR,
LAI,IPER,IPERN,IOR,NBL,IBL,JMAX,N,C,N2,IOP1,IOP2,NMAX,CMAX,N2MAX)
C
    IF (ISORT.EQ.6) STOP
    IF (ISORT.EQ.5.OR.ISORT.EQ.8) GO TO 20
C
    CALL TRICCS (X,SSINIT,CR,CI,ANS,DT,NTAU,N,C,M,N2,EX1,EX2,EX3,EX4,
LEX5,EX6,IPER,IPERN,HH,RRINV,NN,PCINV,BB,2,NMAX,CMAX,MMAX,N2MAX)
C
20  IF (ISORT.EQ.3.OR.ISORT.EQ.7) STOP
C
    CALL COVM (AA,BB,HH,CC,QQ,PP,KC,N,M,C,R,XX,YY,ZZ,UU,YYEST,ZZEST,
IKSIM,A,Q,BSIMO,ASI,NMAX,MMAX,CMAX,RMAX,KSIMAX)
C
    RETURN
    END

```

 RESULTS OF ESTIMATION PROBLEM

TS, SCALING TRANSFORMATION MATRIX ELEMENTS

4.227E-02 6.811E-02 4.784E-02 2.007E-01 2.007E-01 4.780E+00 5.240E-01 1.800E+02 1.629E+01 1.237E-01
 2.691E+00 1.702E+00 2.488E+00 5.816E-01 5.816E-01 2.438E-02 2.236E-01 6.875E-04 7.599E-03 1.000E+00

REAL PART	IMAGINARY PART	ITER
0.17554749E+00	0.25583571E+00	10
0.17554749E+00	-0.25583571E+00	
-0.17554820E+00	0.25583752E+00	4
-0.17554820E+00	-0.25583752E+00	
0.95405209E+00	0.73936897E+00	5
0.95405209E+00	-0.73936897E+00	
-0.95405176E+00	0.73936927E+00	1
-0.95405176E+00	-0.73936927E+00	
-0.49460346E+01	0.	2
0.49460372E+01	0.	
0.11258133E+02	0.50320941E+01	6
0.11258133E+02	-0.50320941E+01	
-0.11258132E+02	0.50320939E+01	4
-0.11258132E+02	-0.50320939E+01	
0.23687773E+02	0.	2
-0.23687792E+02	0.	
0.74650566E+02	0.	2
0.74650578E+02	0.	
-0.21073558E+03	0.	1
0.21073560E+03	0.	

MODIFIED EIGENVECTOR MATRIX OF AAA

-7.1824E-03 2.4436E-02 1.6543E-03 2.2945E-03 1.3713E-03 8.7949E-05 4.4134E-05 -1.2889E-08 -5.6282E-09 -1.3087E-09
 5.1694E-02 7.4184E-02 6.1195E-03 1.0261E-02 4.9169E-03 2.9968E-04 1.5499E-04 -4.3665E-08 -1.8858E-08 -4.3703E-09
 2.0494E-02 1.8433E-02 2.0144E-02 2.0997E-02 1.4913E-02 9.7260E-04 4.8410E-04 -1.4271E-07 -6.2469E-08 -1.4535E-08
 -4.3563E-02 -5.0861E-02 -2.9107E-02 9.8924E-04 9.8565E-04 -5.4600E-03 5.0342E-04 -1.7465E-06 -1.7614E-06 3.6432E-07
 -5.3158E-03 -1.0720E-02 -1.4334E-03 -5.0459E-03 -7.2082E-02 -7.7366E-03 -1.0054E-03 -2.1204E-06 -1.8629E-06 3.7140E-07
 -8.2743E-02 -2.0423E-01 -1.7935E-03 -7.6784E-02 -6.2493E-03 1.7682E-01 4.5837E-01 2.0692E-03 1.9178E-03 -9.8001E-04
 -1.2735E-02 -2.9341E-02 -1.2742E-03 -1.1950E-02 -2.2901E-03 3.2081E-02 -1.9587E-02 2.2863E-05 7.7464E-05 -4.5874E-05
 1.0000E+00 1.0000E+00 1.0000E+00 1.0000E+00 1.0000E+00 1.0000E+00 1.0000E+00 1.0000E+00 1.0000E+00 1.0000E+00
 -4.1123E-02 -4.3704E-02 -3.5124E-02 -4.1953E-02 -2.3453E-02 3.1841E-03 -1.5745E-02 9.0095E-03 3.9092E-02 4.0195E-02
 -6.8321E-04 -7.1575E-04 -6.0758E-04 -6.9370E-04 -4.6097E-04 -1.2881E-04 -3.6341E-04 -6.0893E-05 -2.5902E-04 4.0159E-04
 -3.6322E-01 7.9791E-01 -3.7493E-02 3.2951E-02 5.1685E-04 1.7376E-05 -1.2411E-05 -1.2705E-06 -1.4790E-07 -5.2275E-09
 1.4109E-01 2.3055E-01 -1.1573E-02 5.8929E-02 2.4192E-03 1.2437E-04 -2.3157E-04 -3.0093E-05 -1.1040E-05 -1.1015E-06
 7.8583E-02 -3.0413E-03 3.1917E-02 6.3752E-02 1.1474E-02 2.0490E-04 -3.2484E-03 -7.1283E-04 -8.2416E-04 -2.3212E-04
 4.4631E-02 1.2272E-01 -4.3922E-03 4.1579E-02 2.0761E-03 7.2578E-05 -2.3686E-04 -2.9251E-05 -1.0941E-05 -1.0977E-06
 1.5598E-02 2.7215E-02 2.3999E-03 1.4388E-02 5.0655E-04 2.9665E-05 -2.0115E-04 -2.5174E-05 -1.0391E-05 -1.0773E-06
 -6.7106E-05 2.5848E-06 -9.5638E-05 -7.3477E-05 -3.5436E-05 3.3404E-04 3.0680E-03 7.7177E-06 2.5257E-06 -4.6423E-07
 8.2632E-03 2.0440E-02 3.3777E-05 7.6791E-03 4.4966E-04 1.5170E-03 -1.2978E-02 -2.4104E-05 -3.2358E-06 1.7155E-07
 4.2186E-05 4.4091E-05 4.0039E-05 4.2320E-05 3.7212E-05 2.8310E-05 3.8598E-05 2.5008E-05 1.2035E-05 4.6862E-06
 -9.8131E-04 -1.0030E-03 -9.3047E-04 -9.8926E-04 -8.1595E-04 -4.8706E-04 -7.0791E-04 -4.0763E-04 -1.0158E-04 -1.2452E-05
 -3.8764E-04 1.1900E-04 -1.5842E-03 -2.1373E-04 -4.0123E-03 -9.0488E-03 -5.5031E-03 -9.6647E-03 -7.6221E-03 -2.6643E-03

1.4946E-06 -1.3786E-03 1.9124E-03 3.1017E-03 8.7246E-04 1.8922E-04 -1.5879E-05 4.1084E-06 3.6229E-08 3.6663E-09

6.6506E-04	-5.2146E-04	2.6785E-03	8.6842E-03	2.6753E-03	6.1312E-04	-4.3141E-05	1.3469E-05	1.2013E-07	1.2198E-08
4.4838E-03	-1.0948E-02	2.0397E-02	3.5871E-02	9.7948E-03	2.1129E-03	-1.8139E-04	4.5788E-05	4.0295E-07	4.0751E-08
3.9768E-03	-4.6534E-03	1.7350E-03	4.2925E-02	3.1533E-02	1.4259E-02	4.2051E-03	4.8421E-04	6.8497E-06	5.5850E-07
1.0881E-03	-9.1415E-04	-2.9395E-03	1.4668E-02	1.8851E-02	1.0765E-02	4.2519E-03	4.1670E-04	6.5057E-06	5.4815E-07
2.3215E-02	-1.6498E-02	-1.4038E-01	3.4859E-01	1.0000E+00	1.0000E+00	1.0000E+00	1.0118E-01	5.3766E-03	1.3411E-03
3.2077E-03	-2.3925E-03	-1.5767E-02	4.6729E-02	1.0441E-01	9.2206E-02	7.3968E-02	7.2024E-03	3.1163E-04	7.1059E-05
1.5352E-01	-4.4393E-01	1.0000E+00	1.0000E+00	-4.6405E-01	-6.9102E-01	-2.4976E-01	1.0000E+00	1.0000E+00	1.0000E+00
-7.3801E-03	1.9409E-02	-4.4105E-02	-5.2450E-02	3.6538E-02	4.4994E-02	1.1003E-01	3.2599E-01	7.6559E-02	5.6200E-02
-1.1834E-04	3.1785E-04	-7.2074E-04	-8.2617E-04	5.3768E-04	6.7996E-04	1.4347E-03	3.9844E-03	8.2667E-04	5.7617E-04
1.0000E+00	1.0000E+00	-9.8161E-02	1.2568E-01	-1.2341E-03	-9.7468E-05	2.2706E-05	-3.4871E-05	-3.0284E-07	-1.6890E-08
8.0289E-02	-4.3125E-01	1.8638E-01	-4.7635E-02	6.0167E-03	1.1926E-03	2.3642E-04	8.2561E-04	2.2604E-05	3.5589E-06
-1.2449E-01	5.5216E-02	-2.1331E-01	-9.3226E-02	-3.0026E-02	-1.2299E-02	-8.6589E-03	-1.9558E-02	-1.6874E-03	-7.5000E-04
-1.6350E-02	1.3577E-02	1.0993E-01	-2.3142E-01	6.3809E-03	1.1416E-03	2.3597E-04	8.4914E-04	2.2810E-05	3.5706E-06
-2.3006E-03	3.1427E-03	-3.5686E-02	-2.9937E-02	-4.9014E-01	1.6920E-03	-5.6490E-05	1.0313E-03	2.4120E-05	3.6400E-06
-4.0538E-05	7.5716E-05	-4.5922E-05	-4.0398E-04	-1.3914E-03	2.3508E-03	-8.2280E-03	-3.0358E-04	-7.0286E-06	-6.3442E-07
-2.2950E-03	1.6469E-03	1.3783E-02	-3.4439E-02	-9.3118E-02	-1.6787E-01	-1.9197E-02	-2.9272E-03	-1.2965E-05	-4.1547E-07
6.2742E-06	-1.8355E-05	4.3653E-05	3.9374E-05	-3.7005E-05	-4.9099E-05	-5.2519E-05	7.4430E-05	4.9574E-05	-5.1012E-06
-1.5934E-04	4.4552E-04	-1.0126E-03	-1.0698E-03	6.4708E-04	9.7950E-04	1.0881E-03	-2.7631E-03	-4.7007E-03	7.4997E-05
1.4948E-04	-5.6661E-05	2.1913E-04	1.8218E-03	-3.2370E-03	-5.5969E-03	-1.7289E-02	6.5125E-02	3.5083E-01	-1.5861E-02

THE ORDERED EIGENVALUES OF THE HAMILTONIAN MATRIX
THE ONES WITH NEGATIVE REAL PARTS
ARE THE EIGENVALUES OF (A-KE*H)

REAL PART	IMAGINARY PART
0.17554749E+00	0.25583571E+00
0.17554749E+00	-0.25583571E+00
0.95405209E+00	0.73936897E+00
0.95405209E+00	-0.73936897E+00
0.49460372E+01	0.
0.11258133E+02	0.50320941E+01
0.11258133E+02	-0.50320941E+01
0.23697773E+02	0.
0.74650578E+02	0.
0.21073560E+03	0.
-0.17554820E+00	0.25583752E+00
-0.17554820E+00	-0.25583752E+00
-0.95405176E+00	0.73936527E+00
-0.95405176E+00	-0.73936527E+00
-0.49460346E+01	0.
-0.11258132E+02	0.50320939E+01
-0.11258132E+02	-0.50320939E+01
-0.23697792E+02	0.
-0.74650566E+02	0.
-0.21073558E+03	0.

PP, THE ESTIMATION ERROR COVARIANCE MATRIX

3.6707E+01	6.2551E-01	-2.5906E+00	1.6880E+00	2.1101E-01	8.9035E-03	2.6260E-01	-1.8451E-05	1.4098E-04	8.1850E-02
6.2550E-01	4.2119E+00	9.3036E-01	1.9195E+00	4.7155E-01	9.9546E-03	3.2220E-01	-5.4017E-05	8.1120E-04	1.0958E-01
-2.5906E+00	9.3037E-01	3.1338E+00	1.0412E+00	4.9428E-01	1.3263E-03	2.2359E-01	-6.7886E-04	2.0464E-03	9.3509E-01
1.6880E+00	1.9195E+00	1.0411E+00	1.3388E+00	3.5874E-01	6.7751E-03	2.2687E-01	-4.6996E-05	7.5122E-04	8.0073E-02
2.1101E-01	4.7155E-01	4.9428E-01	3.5875E-01	1.3324E-01	1.6898E-03	6.5911E-02	-3.2528E-05	5.8300E-04	3.1191E-02
8.9035E-03	9.9548E-03	1.3262E-03	6.7754E-03	1.6899E-03	5.8403E-03	-2.0215E-02	-2.9019E-06	7.2609E-06	1.7279E-02
2.6260E-01	3.2219E-01	2.2359E-01	2.2687E-01	6.5910E-02	-2.0215E-02	2.0216E-01	1.1601E-05	-8.3328E-05	-4.6612E-02
-1.8443E-05	-5.3931E-05	-6.7885E-04	-4.6914E-05	-3.2517E-05	-2.9020E-06	1.1617E-05	2.8883E-05	-4.9912E-04	-1.0301E-02
1.4762E-04	8.0928E-04	2.0465E-03	7.4960E-04	5.8279E-04	7.2658E-06	-8.3659E-05	-4.9912E-04	1.0942E-02	1.1665E-01
8.1860E-02	1.0957E-01	9.3508E-01	8.0061E-02	3.1189E-02	1.7279E-02	-4.6614E-02	-1.0301E-02	1.1665E-01	7.3767E+00

KE, THE KALMAN FILTER GAIN MATRIX

3.1657E-02	1.7022E-02	1.1017E-01	9.0070E-03
3.9859E-02	2.2991E-02	1.3032E-01	2.2502E-02
2.5596E-02	-8.5104E-02	6.2530E-02	3.1798E-02
2.8297E-02	1.6813E-02	9.0594E-02	1.7689E-02
8.2013E-03	6.3026E-03	2.4927E-02	6.5474E-03
1.4112E-04	3.5445E-03	2.4148E-02	5.1140E-05
4.8806E-03	-9.1010E-03	-5.0535E-02	3.4388E-03
-1.3241E-06	1.3245E-04	-1.1606E-05	-6.9669E-06
2.2211E-05	4.8406E-02	1.5414E-05	2.3019E-05
1.8546E-03	-7.7111E-01	7.4740E-02	9.7532E-03

 TRANSIENT RICCATI SOLUTION

TIME = 0.

RICCATI SOLUTION MATRIX										
1.0000E+00	0.	0.	0.	0.	0.	0.	0.	0.	0.	0.
0.	1.0000E+00	0.	0.	0.	0.	0.	0.	0.	0.	0.
0.	0.	1.0000E+00	0.	0.	0.	0.	0.	0.	0.	0.
0.	0.	0.	1.0000E+00	0.	0.	0.	0.	0.	0.	0.
0.	0.	0.	0.	1.0000E+00	0.	0.	0.	0.	0.	0.
0.	0.	0.	0.	0.	1.0000E+00	0.	0.	0.	0.	0.
0.	0.	0.	0.	0.	0.	1.0000E+00	0.	0.	0.	0.
0.	0.	0.	0.	0.	0.	0.	1.0000E+00	0.	0.	0.
0.	0.	0.	0.	0.	0.	0.	0.	1.0000E+00	0.	0.
0.	0.	0.	0.	0.	0.	0.	0.	0.	1.0000E+00	0.
0.	0.	0.	0.	0.	0.	0.	0.	0.	0.	1.0000E+00

TIME = 0.20000E+00

RICCATI SOLUTION MATRIX										
1.0605E+00	2.0476E-01	8.8445E-03	3.0300E-02	2.1275E-02	7.5396E-05	4.8683E-03	-1.1432E-06	2.2946E-05	1.2353E-03	
2.0476E-01	1.0610E+00	2.2907E-01	9.8658E-02	7.0029E-02	7.5257E-05	1.7040E-02	-2.9961E-05	5.6794E-04	1.7012E-02	
8.8273E-03	2.2906E-01	1.8750E+00	2.5799E-01	1.9157E-01	-2.8313E-03	6.0890E-02	-6.3902E-04	1.2132E-03	8.9150E-01	
3.0298E-02	9.8657E-02	2.5799E-01	7.2075E-01	2.9839E-02	2.0412E-03	1.0093E-01	-3.3209E-05	5.6436E-04	3.9313E-02	
2.1274E-02	7.0029E-02	1.9157E-01	2.9839E-02	1.6730E-01	5.7901E-04	3.1651E-02	-2.6815E-05	4.7829E-04	2.1072E-02	
7.5166E-05	7.5359E-05	-2.8313E-03	2.0414E-03	5.7902E-04	5.8500E-03	-2.1143E-02	-2.8085E-06	5.2418E-06	1.7171E-02	
4.8717E-03	1.7039E-02	6.0891E-02	1.0092E-01	3.1651E-02	-2.1143E-02	2.2134E-01	1.0851E-05	-6.4231E-05	-4.6595E-02	
-1.0416E-06	-2.9858E-05	-6.3903E-04	-3.3136E-05	-2.6803E-05	-2.8086E-06	1.0866E-05	2.8887E-05	-4.9922E-04	-1.0300E-02	
2.0316E-05	5.6557E-04	1.2134E-03	5.6293E-04	4.7804E-04	5.2464E-06	-6.4544E-05	-4.9922E-04	1.0945E-02	1.1664E-01	
1.2095E-03	1.6996E-02	8.9149E-01	3.9301E-02	2.1069E-02	1.7171E-02	-4.6598E-02	-1.0301E-02	1.1665E-01	7.3764E+00	

KE, THE TRANSIENT ESTIMATE GAIN MATRIX

8.5976E-04	3.3603E-04	1.5941E-03	1.6571E-03							
2.8120E-03	3.2394E-03	4.6362E-03	5.6580E-03							
7.4941E-03	-9.7975E-02	1.0660E-03	1.9445E-02							
1.2512E-02	7.7392E-03	3.5438E-02	2.9032E-03							
3.2864E-03	3.7454E-03	1.0808E-02	2.1449E-03							
4.3683E-05	3.5107E-03	2.3964E-02	-2.8019E-05							
2.2100E-03	-8.9965E-03	-5.0383E-02	6.6441E-04							
-9.9919E-07	1.3201E-04	-1.1327E-05	-6.4808E-06							
1.7353E-05	4.8417E-02	1.0096E-05	1.3849E-05							
1.0064E-03	-7.7122E-01	7.4205E-02	8.9670E-03							

TIME = 0.40000E+00

RICCATI SOLUTION MATRIX										
1.2067E+00	4.3552E-01	5.1399E-02	9.6017E-02	5.1845E-02	4.3323E-04	1.7819E-02	-2.2822E-06	3.7566E-05	4.8755E-03	
4.3552E-01	1.2250E+00	5.1811E-01	2.7814E-01	1.5548E-01	9.8664E-04	5.4824E-02	-3.7118E-05	7.0988E-04	2.6935E-02	
5.1375E-02	5.1810E-01	2.2801E+00	5.2526E-01	3.2136E-01	-1.7422E-03	1.3037E-01	-6.7296E-04	2.0091E-03	9.0658E-01	
9.6013E-02	2.7814E-01	5.2526E-01	6.2592E-01	9.7356E-02	2.6388E-03	9.9612E-02	-3.9404E-05	7.1005E-04	4.1499E-02	
5.1842E-02	1.5548E-01	3.2136E-01	9.7356E-02	8.6130E-02	4.0118E-04	2.5345E-02	-3.0116E-05	5.6968E-04	1.9008E-02	

4.3303E-04	9.8677E-04	-1.7422E-03	2.6390E-03	4.0119E-04	5.8201E-03	-2.0893E-02	-2.8660E-06	7.1143E-06	1.7082E-02
1.7821E-02	5.4822E-02	1.3037E-01	9.9610E-02	2.5345E-02	-2.0893E-02	1.8069E-01	1.2832E-05	-8.9495E-05	-5.3021E-02
-2.1793E-06	-3.7011E-05	-6.7296E-04	-3.9321E-05	-3.0103E-05	-2.8661E-06	1.2849E-05	2.8883E-05	-4.9912E-04	-1.0301E-02
3.4940E-05	7.0747E-04	2.0093E-03	7.0841E-04	5.6942E-04	7.1188E-06	-8.9832E-05	-4.9912E-04	1.0942E-02	1.1665E-01
4.8488E-03	2.6919E-02	9.0658E-01	4.1484E-02	1.9005E-02	1.7082E-02	-5.3024E-02	-1.0301E-02	1.1665E-01	7.3748E+00

KE, THE TRANSIENT ESTIMATE GAIN MATRIX

2.4649E-03	1.1425E-03	6.6209E-03	2.9066E-03
7.2285E-03	5.9430E-03	1.8639E-02	9.2480E-03
1.4113E-02	-9.1009E-02	2.3880E-02	2.4402E-02
1.2057E-02	8.8536E-03	3.8097E-02	6.1734E-03
3.0587E-03	3.7881E-03	8.3423E-03	3.7267E-03
5.0679E-05	3.5041E-03	2.3877E-02	-1.4072E-05
2.0830E-03	-1.0422E-02	-5.9290E-02	1.4842E-03
-1.1573E-06	1.3253E-04	-1.1119E-05	-6.8426E-06
2.1301E-05	4.8405E-02	1.3136E-05	2.2247E-05
1.0084E-03	-7.7150E-01	7.2154E-02	9.1509E-03

TIME = 0.60000E+00

RICCATI SOLUTION MATRIX

1.4518E+00	7.1413E-01	1.1838E-01	2.0983E-01	9.2269E-02	1.0917E-03	3.8363E-02	-3.5028E-06	4.4191E-05	1.1072E-02
7.1412E-01	1.4879E+00	7.9813E-01	5.2356E-01	2.4410E-01	2.4304E-03	9.9644E-02	-3.9857E-05	7.2607E-04	4.0490E-02
1.1836E-01	7.9812E-01	2.5301E+00	7.6147E-01	4.0494E-01	-2.5291E-04	1.7499E-01	-6.7597E-04	2.0311E-03	9.2034E-01
2.0982E-01	5.2356E-01	7.6146E-01	6.6427E-01	1.6895E-01	3.0496E-03	1.1212E-01	-4.0158E-05	7.1484E-04	4.5238E-02
9.2264E-02	2.4410E-01	4.0494E-01	1.6895E-01	9.6732E-02	6.8178E-04	3.5411E-02	-3.0651E-05	5.7235E-04	2.1839E-02
1.0914E-03	2.4305E-03	-2.5288E-04	3.0498E-03	6.8180E-04	5.8201E-03	-2.0843E-02	-2.8648E-06	7.0665E-06	1.7089E-02
3.8364E-02	9.9642E-02	1.7499E-01	1.1211E-01	3.5411E-02	-2.0843E-02	1.8285E-01	1.2755E-05	-8.9500E-05	-5.2477E-02
-3.3989E-06	-3.9749E-05	-6.7598E-04	-4.0070E-05	-3.0638E-05	-2.8649E-06	1.2772E-05	2.8883E-05	-4.9912E-04	-1.0301E-02
4.1531E-05	7.2360E-04	2.0313E-03	7.1307E-04	5.7208E-04	7.0703E-06	-8.9856E-05	-4.9912E-04	1.0942E-02	1.1665E-01
1.1047E-02	4.0477E-02	9.2034E-01	4.5223E-02	2.1836E-02	1.7089E-02	-5.2480E-02	-1.0301E-02	1.1665E-01	7.3750E+00

KE, THE TRANSIENT ESTIMATE GAIN MATRIX

5.0360E-03	2.4208E-03	1.5049E-02	4.6329E-03
1.2797E-02	8.7469E-03	3.7063E-02	1.3088E-02
1.9444E-02	-8.8144E-02	4.2482E-02	2.7802E-02
1.3890E-02	9.6378E-03	4.3277E-02	9.3742E-03
4.4289E-03	4.3752E-03	1.2262E-02	4.8648E-03
6.2206E-05	3.5054E-03	2.3890E-02	5.7451E-06
2.4592E-03	-1.0309E-02	-5.8500E-02	2.0833E-03
-1.1787E-06	1.3253E-04	-1.1131E-05	-6.8821E-06
2.1424E-05	4.8405E-02	1.2888E-05	2.2522E-05
1.1179E-03	-7.7147E-01	7.2324E-02	9.3347E-03

TIME = 0.80000E+00

RICCATI SOLUTION MATRIX

1.8124E+00	1.0505E+00	1.8826E-01	3.7382E-01	1.3909E-01	2.0045E-03	6.6407E-02	-5.1780E-06	5.3126E-05	1.9597E-02
1.0505E+00	1.8185E+00	1.0257E+00	8.0563E-01	3.2522E-01	4.0040E-03	1.4788E-01	-4.2745E-05	7.4154E-04	5.5166E-02
1.8823E-01	1.0257E+00	2.6618E+00	9.4376E-01	4.5386E-01	7.8434E-04	2.0602E-01	-6.7790E-04	2.0421E-03	9.2990E-01
3.7380E-01	8.0562E-01	9.4376E-01	7.7633E-01	3.7194E-01	3.7194E-03	1.3409E-01	-4.1327E-05	7.1950E-04	5.1678E-02
1.3908E-01	3.2522E-01	4.5386E-01	2.3190E-01	1.1242E-01	1.0133E-03	4.5762E-02	-3.1258E-05	5.7547E-04	2.4959E-02
2.0043E-03	4.0042E-03	7.8437E-04	3.7197E-03	1.0133E-03	5.8237E-03	-2.0718E-02	-2.8712E-06	7.0892E-06	1.7125E-02
6.6407E-02	1.4788E-01	2.0602E-01	1.3409E-01	4.5761E-02	-2.0718E-02	1.8694E-01	1.2535E-05	-8.8591E-05	-5.1277E-02

-5.0773E-06 -4.2640E-05 -6.7790E-04 -4.1237E-05 -3.1245E-05 -2.8713E-06 1.2552E-05 2.8883E-05 -4.9912E-04 -1.0301E-02
 5.0546E-05 7.3919E-04 2.0424E-03 7.1771E-04 5.7523E-04 7.0928E-06 -8.8948E-05 -4.9912E-04 1.0942E-02 1.1665E-01
 1.9572E-02 5.5152E-02 9.2990E-01 5.1663E-02 2.4956E-02 1.7125E-02 -5.1280E-02 -1.0301E-02 1.1665E-01 7.3753E+00

KE, THE TRANSIENT ESTIMATE GAIN MATRIX

8.5591E-03 4.1768E-03 2.6624E-02 6.6654E-03
 1.9851E-02 1.1770E-02 5.6990E-02 1.6658E-02
 2.3298E-02 -8.6173E-02 5.5425E-02 2.9864E-02
 1.6807E-02 1.0963E-02 5.2121E-02 1.2191E-02
 5.7399E-03 5.0177E-03 1.6507E-02 5.6394E-03
 7.8898E-05 3.5128E-03 2.3939E-02 2.1660E-05
 2.9991E-03 -1.0062E-02 -5.6854E-02 2.5635E-03
 -1.2083E-06 1.3251E-04 -1.1218E-05 -6.9115E-06
 2.1553E-05 4.8405E-02 1.3227E-05 2.2687E-05
 1.2772E-03 -7.7140E-01 7.2804E-02 9.4820E-03

TIME = 0.10000E+01

RICCATI SOLUTION MATRIX

2.3020E+00 1.4385E+00 2.3605E-01 5.7750E-01 1.8703E-01 3.1150E-03 1.0020E-01 -7.2350E-06 6.4534E-05 2.9926E-02
 1.4385E+00 2.1722E+00 1.1784E+00 1.0887E+00 3.9178E-01 5.5439E-03 1.9476E-01 -4.5596E-05 7.5733E-04 6.9491E-02
 2.3602E-01 1.1784E+00 2.7135E+00 1.0621E+00 4.7785E-01 1.4298E-03 2.2531E-01 -6.7910E-04 2.0491E-03 9.3585E-01
 5.7749E-01 1.0887E+00 1.0621E+00 9.1412E-01 2.8148E-01 4.4901E-03 1.5852E-01 -4.2718E-05 7.2619E-04 5.8982E-02
 1.8702E-01 3.9178E-01 4.7785E-01 2.8149E-01 1.2323E-01 1.2803E-03 5.3877E-02 -3.1753E-05 5.7824E-04 2.7442E-02
 3.1148E-03 5.5441E-03 1.4298E-03 4.4903E-03 1.2803E-03 5.8280E-03 -2.0582E-02 -2.8789E-06 7.1260E-06 1.7165E-02
 1.0020E-01 1.9476E-01 2.2531E-01 1.5852E-01 5.3877E-02 -2.0582E-02 1.9120E-01 1.2289E-05 -8.7377E-05 -4.9998E-02
 -7.1363E-06 -4.5493E-05 -6.7911E-04 -4.2628E-05 -3.1741E-05 -2.8790E-06 1.2307E-05 2.8883E-05 -4.9912E-04 -1.0301E-02
 6.2017E-05 7.5504E-04 2.0494E-03 7.2441E-04 5.7801E-04 7.1299E-06 -8.7734E-05 -4.9912E-04 1.0942E-02 1.1665E-01
 2.9902E-02 6.9478E-02 9.3585E-01 5.8966E-02 2.7439E-02 1.7165E-02 -5.0001E-02 -1.0301E-02 1.1665E-01 7.3757E+00

KE, THE TRANSIENT ESTIMATE GAIN MATRIX

1.2745E-02 6.3046E-03 4.0625E-02 8.7479E-03
 2.4679E-02 1.4721E-02 7.6409E-02 1.9595E-02
 2.5671E-02 -8.4945E-02 6.3477E-02 3.0882E-02
 1.9931E-02 1.2466E-02 6.2081E-02 1.4407E-02
 6.7466E-03 5.5293E-03 1.9871E-02 6.1221E-03
 9.6197E-05 3.5212E-03 2.3994E-02 3.3734E-05
 3.5406E-03 -9.7990E-03 -5.5112E-02 2.9276E-03
 -1.2397E-06 1.3250E-04 -1.1318E-05 -6.9340E-06
 2.1711E-05 4.8405E-02 1.3716E-05 2.2815E-05
 1.4404E-03 -7.7132E-01 7.3326E-02 9.5938E-03

TIME = 0.12000E+01

RICCATI SOLUTION MATRIX

2.9264E+00 1.8585E+00 2.4157E-01 8.0190E-01 2.3078E-01 4.3254E-03 1.3658E-01 -9.4933E-06 7.7568E-05 4.1122E-02
 1.8585E+00 2.5068E+00 1.2546E+00 1.3425E+00 4.4084E-01 6.9089E-03 2.3581E-01 -4.8141E-05 7.7200E-04 8.2119E-02
 2.4154E-01 1.2546E+00 2.7220E+00 1.1214E+00 4.8568E-01 1.7465E-03 2.3459E-01 -6.7970E-04 2.0528E-03 9.3875E-01
 8.0189E-01 1.3425E+00 1.1214E+00 1.0448E+00 3.1666E-01 5.2047E-03 1.8058E-01 -4.4030E-05 7.3315E-04 6.5672E-02
 2.3077E-01 4.4084E-01 4.8568E-01 3.1666E-01 1.2936E-01 1.4688E-03 5.9505E-02 -3.2106E-05 5.8031E-04 2.9180E-02
 4.3252E-03 6.9091E-03 1.7466E-03 5.2049E-03 1.4688E-03 5.8319E-03 -2.0462E-02 -2.8860E-06 7.1645E-06 1.7202E-02
 1.3658E-01 2.3581E-01 2.3458E-01 1.8058E-01 5.9505E-02 -2.0462E-02 1.9490E-01 1.2068E-05 -8.6185E-05 -4.8875E-02
 -9.4901E-06 -4.8045E-05 -6.7971E-04 -4.3942E-05 -3.2095E-05 -2.8862E-06 1.2085E-05 2.8883E-05 -4.9912E-04 -1.0301E-02
 7.5143E-05 7.6980E-04 2.0532E-03 7.3141E-04 5.8009E-04 7.1684E-06 -8.6534E-05 -4.9912E-04 1.0942E-02 1.1665E-01

4.1100E-02 8.2109E-02 9.3875E-01 6.5658E-02 2.9178E-02 1.7202E-02 -4.8877E-02 -1.0301E-02 1.1665E-01 7.3760E+00

KE, THE TRANSIENT ESTIMATE GAIN MATRIX

1.7215E-02 8.6130E-03 5.5772E-02 1.0625E-02
 2.9729E-02 1.7325E-02 9.3497E-02 2.1739E-02
 2.6790E-02 -8.4348E-02 6.7379E-02 3.1201E-02
 2.2695E-02 1.3844E-02 7.1168E-02 1.5963E-02
 7.4352E-03 5.8877E-03 2.2220E-02 6.3870E-03
 1.1125E-04 3.5287E-03 2.4044E-02 4.2086E-05
 4.0021E-03 -9.5675E-03 -5.3586E-02 3.1762E-03
 -1.2675E-06 1.3248E-04 -1.1410E-05 -6.9497E-06
 2.1863E-05 4.8405E-02 1.4209E-05 2.2909E-05
 1.5809E-03 -7.7125E-01 7.3790E-02 9.6708E-03

TIME = 0.14000E+01

RICCATI SOLUTION MATRIX

3.6827E+00 2.2850E+00 1.9430E-01 1.0262E+00 2.6638E-01 5.5267E-03 1.7221E-01 -1.1755E-05 9.1075E-05 5.2169E-02
 2.2850E+00 2.7930E+00 1.2681E+00 1.5496E+00 4.7308E-01 8.0137E-03 2.6859E-01 -5.0222E-05 7.8442E-04 9.2279E-02
 1.9427E-01 1.2681E+00 2.7162E+00 1.1361E+00 4.8470E-01 1.8221E-03 2.3662E-01 -6.7985E-04 2.0540E-03 9.3941E-01
 1.0262E+00 1.5496E+00 1.1361E+00 1.1509E+00 3.3902E-01 5.7786E-03 1.9794E-01 -4.5098E-05 7.3919E-04 7.0996E-02
 2.6637E-01 4.7308E-01 4.8470E-01 3.3902E-01 1.3224E-01 1.5876E-03 6.2992E-02 -3.2331E-05 5.8169E-04 3.0267E-02
 5.5265E-03 8.0139E-03 1.8222E-03 5.7788E-03 1.5877E-03 5.8350E-03 -2.0369E-02 -2.8918E-06 7.1972E-06 1.7230E-02
 1.7221E-01 2.6858E-01 2.3662E-01 1.9794E-01 6.2991E-02 -2.0369E-02 1.9772E-01 1.1893E-05 -8.5186E-05 -4.8007E-02
 -1.1665E-05 -5.0127E-05 -6.7986E-04 -4.5012E-05 -3.2321E-05 -2.8919E-06 1.1910E-05 2.8883E-05 -4.9912E-04 -1.0301E-02
 8.8787E-05 7.8233E-04 2.0543E-03 7.3749E-04 5.8149E-04 7.2014E-06 -8.5529E-05 -4.9912E-04 1.0942E-02 1.1665E-01
 5.2148E-02 9.2271E-02 9.3941E-01 7.0983E-02 3.0265E-02 1.7231E-02 -4.8010E-02 -1.0301E-02 1.1665E-01 7.3763E+00

KE, THE TRANSIENT ESTIMATE GAIN MATRIX

2.1548E-02 1.0889E-02 7.0686E-02 1.2113E-02
 3.3718E-02 1.9418E-02 1.0722E-01 2.3116E-02
 2.7018E-02 -8.4211E-02 6.8266E-02 3.1142E-02
 2.4837E-02 1.4940E-02 7.8377E-02 1.6933E-02
 7.8559E-03 6.1117E-03 2.3686E-02 6.5060E-03
 1.2280E-04 3.5346E-03 2.4083E-02 4.7237E-05
 4.3496E-03 -9.3889E-03 -5.2413E-02 3.3269E-03
 -1.2891E-06 1.3247E-04 -1.1482E-05 -6.9594E-06
 2.1987E-05 4.8405E-02 1.4625E-05 2.2970E-05
 1.6878E-03 -7.7120E-01 7.4150E-02 9.7179E-03

TIME = 0.16000E+01

RICCATI SOLUTION MATRIX

4.5616E+00 2.6944E+00 9.3476E-02 1.2332E+00 2.9185E-01 6.6289E-03 2.0444E-01 -1.3846E-05 1.0405E-04 6.2239E-02
 2.6944E+00 3.0177E+00 1.2392E+00 1.7052E+00 4.9151E-01 8.8384E-03 2.9270E-01 -5.1786E-05 7.9413E-04 9.9813E-02
 9.3451E-02 1.2392E+00 2.7140E+00 1.1232E+00 4.8027E-01 1.7511E-03 2.3436E-01 -6.7572E-04 2.0533E-03 9.3874E-01
 1.2332E+00 1.7052E+00 1.1232E+00 1.2278E+00 3.5154E-01 6.1908E-03 2.1019E-01 -4.5873E-05 7.4380E-04 7.4789E-02
 2.9185E-01 4.9152E-01 4.8027E-01 3.5155E-01 1.3317E-01 1.6536E-03 6.4884E-02 -3.2457E-05 5.8251E-04 3.0864E-02
 6.6287E-03 8.8386E-03 1.7511E-03 6.1911E-03 1.6536E-03 5.8372E-03 -2.0303E-02 -2.8960E-06 7.2220E-06 1.7251E-02
 2.0444E-01 2.9269E-01 2.3436E-01 2.1018E-01 6.4883E-02 -2.0303E-02 1.9966E-01 1.1770E-05 -8.4447E-05 -4.7405E-02
 -1.3762E-05 -5.1695E-05 -6.7973E-04 -4.5788E-05 -3.2447E-05 -2.8961E-06 1.1787E-05 2.8883E-05 -4.9912E-04 -1.0301E-02
 1.0190E-04 7.9214E-04 2.0537E-03 7.4214E-04 5.8232E-04 7.2264E-06 -8.4782E-05 -4.9912E-04 1.0942E-02 1.1665E-01
 6.2221E-02 9.9807E-02 9.3874E-01 7.4777E-02 3.0863E-02 1.7251E-02 -4.7408E-02 -1.0301E-02 1.1665E-01 7.3765E+00

KE, THE TRANSIENT ESTIMATE GAIN MATRIX

2.5423E-02	1.2965E-02	8.4254E-02	1.3123E-02
3.6619E-02	2.0971E-02	1.1737E-01	2.3870E-02
2.6730E-02	-8.4350E-02	6.7347E-02	3.0942E-02
2.6329E-02	1.5722E-02	8.3500E-02	1.7458E-02
8.0803E-03	6.2349E-03	2.4489E-02	6.5399E-03
1.3077E-04	3.5388E-03	2.4110E-02	4.9993E-05
4.5854E-03	-9.2648E-03	-5.1600E-02	3.4057E-03
-1.3042E-06	1.3247E-04	-1.1534E-05	-6.9647E-06
2.2079E-05	4.8406E-02	1.4936E-05	2.3005E-05
1.7610E-03	-7.7116E-01	7.4402E-02	9.7428E-03

TIME = 0.18000E+01

RICCATI SOLUTION MATRIX

5.5504E+00	3.0684E+00	-5.4718E-02	1.4117E+00	3.0696E-01	7.5738E-03	2.3163E-01	-1.5653E-05	1.1572E+04	7.0812E-02
3.0684E+00	3.1810E+00	1.1876E+00	1.8137E+00	4.9998E-01	9.4099E-03	3.0913E-01	-5.2880E-05	8.0121E-04	1.0500E-01
-5.4741E-02	1.1876E+00	2.7232E+00	1.0975E+00	4.7565E-01	1.6128E-03	2.3023E-01	-6.7946E-04	2.0518E-03	9.3746E-01
1.4117E+00	1.8137E+00	1.0975E+00	1.2783E+00	3.5743E-01	6.4591E-03	2.1801E-01	-4.6383E-05	7.4699E-04	7.7238E-02
3.0695E-01	4.9998E-01	4.7565E-01	3.5743E-01	1.3313E-01	1.6841E-03	6.5730E-02	-3.2517E-05	5.8293E-04	3.1137E-02
7.5736E-03	9.4102E-03	1.6128E-03	6.4594E-03	1.6841E-03	5.8386E-03	-2.0261E-02	-2.8987E-06	7.2391E-06	1.7264E-02
2.3163E-01	3.0913E-01	2.3022E-01	2.1801E-01	6.5729E-02	-2.0261E-02	2.0087E-01	1.1691E-05	-8.3948E-05	-4.7026E-02
-1.5575E-05	-5.2793E-05	-6.7947E-04	-4.6299E-05	-3.2507E-05	-2.8988E-06	1.1707E-05	2.8883E-05	-4.9912E-04	-1.0301E-02
1.1371E-04	7.9930E-04	2.0521E-03	7.4536E-04	5.8274E-04	7.2435E-06	-8.4278E-05	-4.5912E-04	1.0942E-02	1.1665E-01
7.0796E-02	1.0499E-01	9.3746E-01	7.7226E-02	3.1135E-02	1.7264E-02	-4.7029E-02	-1.0301E-02	1.1665E-01	7.3766E+00

KE, THE TRANSIENT ESTIMATE GAIN MATRIX

2.8650E-02	1.4734E-02	9.5776E-02	1.3653E-02
3.8569E-02	2.2041E-02	1.2433E-01	2.4181E-02
2.6224E-02	-8.4613E-02	6.5621E-02	3.0746E-02
2.7267E-02	1.6227E-02	8.6798E-02	1.7686E-02
8.1777E-03	6.2911E-03	2.4853E-02	6.5327E-03
1.3575E-04	3.5415E-03	2.4128E-02	5.1175E-05
4.7299E-03	-9.1867E-03	-5.1090E-02	3.4381E-03
-1.3137E-06	1.3246E-04	-1.1567E-05	-6.9671E-06
2.2140E-05	4.8406E-02	1.5148E-05	2.3022E-05
1.8064E-03	-7.7113E-01	7.4562E-02	9.7533E-03

TIME = 0.20000E+01

RICCATI SOLUTION MATRIX

6.6359E+00	3.3953E+00	-2.4047E-01	1.5562E+00	3.1266E-01	8.3343E-03	2.5308E-01	-1.7126E-05	1.2564E-04	7.7651E-02
3.3953E+00	3.2905E+00	1.1287E+00	1.8841E+00	5.0205E-01	9.7776E-03	3.1948E-01	-5.3593E-05	8.0604E-04	1.0830E-01
-2.4049E-01	1.1287E+00	2.7453E+00	1.0691E+00	4.7243E-01	1.4619E-03	2.2583E-01	-6.7517E-04	2.0500E-03	9.3609E-01
1.5562E+00	1.8841E+00	1.0691E+00	1.3082E+00	3.5935E-01	6.6172E-03	2.2252E-01	-4.6687E-05	7.4899E-04	7.8666E-02
3.1265E-01	5.0206E-01	4.7243E-01	3.5935E-01	1.3274E-01	1.6937E-03	6.5972E-02	-3.2537E-05	5.8309E-04	3.1219E-02
8.3341E-03	9.7779E-03	1.4619E-03	6.6175E-03	1.6937E-03	5.8395E-03	-2.0238E-02	-2.9003E-06	7.2497E-06	1.7271E-02
2.5308E-01	3.1948E-01	2.2583E-01	2.2251E-01	6.5971E-02	-2.0238E-02	2.0154E-01	1.1645E-05	-8.3643E-05	-4.6812E-02
-1.7052E-05	-5.3507E-05	-6.7918E-04	-4.6604E-05	-3.2527E-05	-2.9004E-06	1.1661E-05	2.8883E-05	-4.9912E-04	-1.0301E-02
1.2377E-04	8.0418E-04	2.0503E-03	7.4739E-04	5.8291E-04	7.2543E-06	-8.3970E-05	-4.9912E-04	1.0942E-02	1.1665E-01
7.7637E-02	1.0830E-01	9.3608E-01	7.8655E-02	3.1217E-02	1.7271E-02	-4.6814E-02	-1.0301E-02	1.1665E-01	7.3767E+00

KE, THE TRANSIENT ESTIMATE GAIN MATRIX

3.1154E-02	1.6144E-02	1.0494E-01	1.3754E-02
3.9777E-02	2.2722E-02	1.2876E-01	2.4214E-02
2.5698E-02	-8.4897E-02	6.3767E-02	3.0623E-02
2.7798E-02	1.6521E-02	8.8715E-02	1.7744E-02
8.2031E-03	6.3081E-03	2.4961E-02	6.5119E-03
1.3855E-04	3.5430E-03	2.4138E-02	5.1453E-05
4.8091E-03	-9.1425E-03	-5.0803E-02	3.4445E-03
-1.3191E-06	1.3246E-04	-1.1597E-05	-6.9677E-06
2.2176E-05	4.8406E-02	1.5279E-05	2.3027E-05
1.8316E-03	-7.7112E-01	7.4653E-02	9.7556E-03

TIME = 0.22000E+01

RICCATI SOLUTION MATRIX										
7.8051E+00	3.6691E+00	-4.5284E-01	1.6658E+00	3.1054E-01	8.9069E-03	2.6880E-01	-1.8247E-05	1.3364E-04	8.2740E-02	
3.6691E+00	3.3572E+00	1.0726E+00	1.9262E+00	5.0057E-01	9.9952E-03	3.2543E-01	-5.4020E-05	8.0911E-04	1.1023E-01	
-4.5284E-01	1.0726E+00	2.7777E+00	1.0441E+00	4.7108E-01	1.3296E-03	2.2208E-01	-6.7892E-04	2.0483E-03	9.3490E-01	
1.6658E+00	1.9262E+00	1.0440E+00	1.3240E+00	3.5925E-01	6.6999E-03	2.2480E-01	-4.6848E-05	7.5012E-04	7.9404E-02	
3.1054E-01	5.0057E-01	4.7108E-01	3.5925E-01	1.3231E-01	1.6927E-03	6.5919E-02	-3.2536E-05	5.8311E-04	3.1207E-02	
8.9069E-03	9.9955E-03	1.3296E-03	6.7001E-03	1.6928E-03	5.8399E-03	-2.0226E-02	-2.9011E-06	7.2557E-06	1.7275E-02	
2.6880E-01	3.2543E-01	2.2208E-01	2.2480E-01	6.5918E-02	-2.0226E-02	2.0187E-01	1.1622E-05	-8.3477E-05	-4.6706E-02	
-1.8180E-05	-5.3937E-05	-6.7892E-04	-4.6766E-05	-3.2526E-05	-2.9013E-06	1.1638E-05	2.8883E-05	-4.9912E-04	-1.0301E-02	
1.3191E-04	8.0730E-04	2.0486E-03	7.4855E-04	5.8293E-04	7.2604E-06	-8.3800E-05	-4.9912E-04	1.0942E-02	1.1665E-01	
8.2729E-02	1.1023E-01	9.3489E-01	7.9392E-02	3.1205E-02	1.7275E-02	-4.6709E-02	-1.0301E-02	1.1665E-01	7.3767E+00	

KE, THE TRANSIENT ESTIMATE GAIN MATRIX

3.2946E-02	1.7196E-02	1.1173E-01	1.3503E-02
4.0454E-02	2.3122E-02	1.3133E-01	2.4100E-02
2.5257E-02	-8.5142E-02	6.2168E-02	3.0588E-02
2.8060E-02	1.6674E-02	8.9699E-02	1.7718E-02
8.1944E-03	6.3058E-03	2.4943E-02	6.4920E-03
1.3991E-04	3.5438E-03	2.4143E-02	5.1299E-05
4.8462E-03	-9.1206E-03	-5.0662E-02	3.4390E-03
-1.3218E-06	1.3246E-04	-1.1597E-05	-6.9674E-06
2.2196E-05	4.8406E-02	1.5352E-05	2.3027E-05
1.8437E-03	-7.7111E-01	7.4699E-02	9.7540E-03

TIME = 0.24000E+01

RICCATI SOLUTION MATRIX										
9.0451E+00	3.8877E+00	-6.8134E-01	1.7426E+00	3.0243E-01	9.3039E-03	2.7925E-01	-1.9041E-05	1.3971E-04	8.6207E-02	
3.8877E+00	3.3922E+00	1.0253E+00	1.9488E+00	4.9751E-01	1.0110E-02	3.2843E-01	-5.4251E-05	8.1088E-04	1.1123E-01	
-6.8134E-01	1.0253E+00	2.8167E+00	1.0249E+00	4.7141E-01	1.2297E-03	2.1933E-01	-6.7872E-04	2.0469E-03	9.3401E-01	
1.7426E+00	1.9488E+00	1.0249E+00	1.3310E+00	3.5836E-01	6.7360E-03	2.2574E-01	-4.6920E-05	7.5067E-04	7.9717E-02	
3.0243E-01	4.9751E-01	4.7141E-01	3.5837E-01	1.3201E-01	1.6878E-03	6.5763E-02	-3.2527E-05	5.8306E-04	3.1160E-02	
9.3039E-03	1.0111E-02	1.2297E-03	6.7362E-03	1.6878E-03	5.8401E-03	-2.0221E-02	-2.9015E-06	7.2585E-06	1.7277E-02	
2.7925E-01	3.2843E-01	2.1933E-01	2.2574E-01	6.5762E-02	-2.0221E-02	2.0199E-01	1.1612E-05	-8.3403E-05	-4.6665E-02	
-1.8980E-05	-5.4170E-05	-6.7873E-04	-4.6839E-05	-3.2517E-05	-2.9017E-06	1.1628E-05	2.8883E-05	-4.9912E-04	-1.0301E-02	
1.3191E-04	8.0914E-04	2.0472E-03	7.4912E-04	5.8288E-04	7.2634E-06	-8.3720E-05	-4.9912E-04	1.0942E-02	1.1665E-01	
8.6197E-02	1.1123E-01	9.3400E-01	7.9706E-02	3.1159E-02	1.7277E-02	-4.6667E-02	-1.0301E-02	1.1665E-01	7.3767E+00	

KE, THE TRANSIENT ESTIMATE GAIN MATRIX

3.4091E-02	1.7912E-02	1.1633E-01	1.2990E-02
4.0780E-02	2.3328E-02	1.3266E-01	2.3928E-02

2.4944E-02	-8.5327E-02	6.0982E-02	3.0630E-02
2.8162E-02	1.6738E-02	9.0115E-02	1.7664E-02
8.1746E-03	6.2960E-03	2.4880E-02	6.4788E-03
1.4043E-04	3.5442E-03	2.4145E-02	5.1003E-05
4.8593E-03	-9.1121E-03	-5.0607E-02	3.4299E-03
-1.3229E-06	1.3246E-04	-1.1601E-05	-6.9669E-06
2.2204E-05	4.8406E-02	1.5387E-05	2.3024E-05
1.8481E-03	-7.7111E-01	7.4717E-02	9.7513E-03

TIME = 0.26000E+01

RICCATI SOLUTION MATRIX

1.0344E+01	4.0520E+00	-9.1662E-01	1.7905E+00	2.9009E-01	9.5469E-03	2.8514E-01	-1.9546E-05	1.4410E-04	8.8258E-02
4.0520E+00	3.4053E+00	9.8906E-01	1.9591E+00	4.9413E-01	1.0161E-02	3.2963E-01	-5.4359E-05	8.1190E-04	1.1166E-01
-9.1663E-01	9.8907E-01	2.8584E+00	1.0123E+00	4.7299E-01	1.1642E-03	2.1763E-01	-6.7859E-04	2.0459E-03	9.3344E-01
1.7905E+00	1.9591E+00	1.0122E+00	1.3332E+00	3.5737E-01	6.7465E-03	2.2597E-01	-4.6944E-05	7.5094E-04	7.9802E-02
2.9008E-01	4.9413E-01	4.7299E-01	3.5737E-01	1.3187E-01	1.6824E-03	6.5606E-02	-3.2517E-05	5.8301E-04	3.1111E-02
9.5468E-03	1.0162E-02	1.1642E-03	6.7468E-03	1.6825E-03	5.8401E-03	-2.0220E-02	-2.9616E-06	7.2598E-06	1.7277E-02
2.8514E-01	3.2962E-01	2.1762E-01	2.2597E-01	6.5605E-02	-2.0220E-02	2.0201E-01	1.1609E-05	-8.3368E-05	-4.6657E-02
-1.9489E-05	-5.4278E-05	-6.7859E-04	-4.6863E-05	-3.2507E-05	-2.9018E-06	1.1626E-05	2.8883E-05	-4.9912E-04	-1.0301E-02
1.4259E-04	8.1012E-04	2.0461E-03	7.4935E-04	5.8282E-04	7.2646E-06	-8.3692E-05	-4.9912E-04	1.0942E-02	1.1665E-01
8.8250E-02	1.1165E-01	-9.3343E-01	7.9791E-02	3.1110E-02	1.7277E-02	-4.6659E-02	-1.0301E-02	1.1665E-01	7.3767E+00

KE, THE TRANSIENT ESTIMATE GAIN MATRIX

3.4693E-02	1.8338E-02	1.1902E-01	1.2299E-02
4.0896E-02	2.3417E-02	1.3321E-01	2.3753E-02
2.4759E-02	-8.5443E-02	6.0228E-02	3.0727E-02
2.8181E-02	1.6757E-02	9.0225E-02	1.7611E-02
8.1557E-03	6.2861E-03	2.4814E-02	6.4734E-03
1.4052E-04	3.5442E-03	2.4146E-02	5.0719E-05
4.8695E-03	-9.1103E-03	-5.0597E-02	3.4217E-03
-1.3231E-06	1.3246E-04	-1.1602E-05	-6.9663E-06
2.2207E-05	4.8406E-02	1.5400E-05	2.3020E-05
1.8487E-03	-7.7111E-01	7.4721E-02	9.7487E-03

TIME = 0.28000E+01

RICCATI SOLUTION MATRIX

1.1688E+01	4.1645E+00	-1.1508E+00	1.8141E+00	2.7513E-01	9.6614E-03	2.8730E-01	-1.9805E-05	1.4688E-04	8.9138E-02
4.1645E+00	3.4046E+00	9.6431E-01	1.9623E+00	4.9114E-01	1.0175E-02	3.2982E-01	-5.4393E-05	8.1231E-04	1.1176E-01
-1.1508E+00	9.6433E-01	2.8997E+00	1.0053E+00	4.7532E-01	1.1291E-03	2.1681E-01	-6.7852E-04	2.0452E-03	9.3315E-01
1.8141E+00	1.9623E+00	1.0053E+00	1.3330E+00	3.5660E-01	6.7454E-03	2.2588E-01	-4.6944E-05	7.5097E-04	7.9785E-02
2.7513E-01	4.9114E-01	4.7532E-01	3.5660E-01	1.3186E-01	1.6783E-03	6.5491E-02	-3.2509E-05	5.8295E-04	3.1075E-02
9.6613E-03	1.0176E-02	1.1291E-03	6.7456E-03	1.6783E-03	5.8401E-03	-2.0220E-02	-2.9616E-06	7.2600E-06	1.7277E-02
2.8729E-01	3.2982E-01	2.1681E-01	2.2588E-01	6.5490E-02	-2.0220E-02	2.0199E-01	1.1610E-05	-8.3368E-05	-4.6662E-02
-1.9753E-05	-5.4312E-05	-6.7852E-04	-4.6862E-05	-3.2499E-05	-2.9018E-06	1.1626E-05	2.8883E-05	-4.9912E-04	-1.0301E-02
1.4550E-04	8.1056E-04	2.0454E-03	7.4940E-04	5.8276E-04	7.2648E-06	-8.3689E-05	-4.9912E-04	1.0942E-02	1.1665E-01
8.9132E-02	1.1175E-01	-9.3314E-01	7.9773E-02	3.1073E-02	1.7277E-02	-4.6665E-02	-1.0301E-02	1.1665E-01	7.3767E+00

KE, THE TRANSIENT ESTIMATE GAIN MATRIX

3.4828E-02	1.8521E-02	1.2013E-01	1.1505E-02
4.0900E-02	2.3437E-02	1.3333E-01	2.3605E-02
2.4682E-02	-8.5504E-02	5.9849E-02	3.0854E-02
2.8166E-02	1.6753E-02	9.0197E-02	1.7572E-02

8.1425E-03	6.2785E-03	2.4764E-02	6.4743E-03
1.4043E-04	3.5442E-03	2.4146E-02	5.0513E-05
4.8571E-03	-9.1115E-03	-5.0605E-02	3.4161E-03
-1.3229E-06	1.3246E-04	-1.1602E-05	-6.9659E-06
2.2207E-05	4.8406E-02	1.5402E-05	2.3017E-05
1.8478E-03	-7.7111E-01	7.4719E-02	9.7469E-03

TIME = 0.30000E+01

RICCATI SOLUTION MATRIX

1.3066E+01	4.2290E+00	-1.3775E+00	1.8185E+00	2.5893E-01	9.6745E-03	2.8655E-01	-1.9869E-05	1.4842E-04	8.9102E-02
4.2290E+00	3.3963E+00	9.5003E-01	1.9620E+00	4.8885E-01	1.0172E-02	3.2957E-01	-5.4390E-05	8.1243E-04	1.1170E-01
-1.3775E+00	9.5005E-01	2.9383E+00	1.0028E+00	4.7798E-01	1.1176E-03	2.1667E-01	-6.7849E-04	2.0448E-03	9.3307E-01
1.8185E+00	1.9620E+00	1.0027E+00	1.3322E+00	3.5613E-01	6.7404E-03	2.2572E-01	-4.6935E-05	7.5093E-04	7.9736E-02
2.5893E-01	4.8885E-01	4.7798E-01	3.5613E-01	1.3194E-01	1.6759E-03	6.5430E-02	-3.2503E-05	5.8290E-04	3.1054E-02
9.6745E-03	1.0172E-02	1.1176E-03	6.7407E-03	1.6759E-03	5.8401E-03	-2.0221E-02	-2.9016E-06	7.2598E-06	1.7277E-02
2.8655E-01	3.2957E-01	2.1667E-01	2.2571E-01	6.5429E-02	-2.0221E-02	2.0196E-01	1.1612E-05	-8.3378E-05	-4.6671E-02
-1.9821E-05	-5.4310E-05	-6.7849E-04	-4.6854E-05	-3.2494E-05	-2.9017E-06	1.1628E-05	2.8883E-05	-4.9912E-04	-1.0301E-02
1.4712E-04	8.1070E-04	2.0450E-03	7.4938E-04	5.8272E-04	7.2646E-06	-8.3697E-05	-4.9912E-04	1.0942E-02	1.1665E-01
8.9096E-02	1.1170E-01	9.3306E-01	7.9725E-02	3.1052E-02	1.7277E-02	-4.6674E-02	-1.0301E-02	1.1665E-01	7.3767E+00

KE, THE TRANSIENT ESTIMATE GAIN MATRIX

3.4631E-02	1.8515E-02	1.2001E-01	1.0672E-02
4.0856E-02	2.3426E-02	1.3325E-01	2.3495E-02
2.4684E-02	-8.5521E-02	5.9757E-02	3.0993E-02
2.8144E-02	1.6743E-02	9.0131E-02	1.7550E-02
8.1361E-03	6.2741E-03	2.4737E-02	6.4794E-03
1.4031E-04	3.5442E-03	2.4145E-02	5.0398E-05
4.8533E-03	-9.1133E-03	-5.0617E-02	3.4133E-03
-1.3227E-06	1.3246E-04	-1.1602E-05	-6.9657E-06
2.2206E-05	4.8406E-02	1.5399E-05	2.3015E-05
1.8467E-03	-7.7111E-01	7.4716E-02	9.7459E-03

TIME = 0.32000E+01

RICCATI SOLUTION MATRIX

1.4465E+01	4.2500E+00	-1.5918E+00	1.8084E+00	2.4259E-01	9.6119E-03	2.8371E-01	-1.9787E-05	1.4892E-04	8.8388E-02
4.2499E+00	3.3849E+00	9.4458E-01	1.9604E+00	4.8733E-01	1.0162E-02	3.2920E-01	-5.4375E-05	8.1242E-04	1.1160E-01
-1.5918E+00	9.4459E-01	2.9726E+00	1.0034E+00	4.8063E-01	1.1224E-03	2.1699E-01	-6.7849E-04	2.0447E-03	9.3314E-01
1.8084E+00	1.9604E+00	1.0033E+00	1.3313E+00	3.5595E-01	6.7359E-03	2.2558E-01	-4.6927E-05	7.5089E-04	7.9695E-02
2.4258E-01	4.8733E-01	4.8063E-01	3.5595E-01	1.3207E-01	1.6750E-03	6.5414E-02	-3.2502E-05	5.8288E-04	3.1047E-02
9.6118E-03	1.0162E-02	1.1224E-03	6.7362E-03	1.6750E-03	5.8401E-03	-2.0222E-02	-2.9015E-06	7.2596E-06	1.7277E-02
2.8371E-01	3.2920E-01	2.1698E-01	2.2558E-01	6.5414E-02	-2.0222E-02	2.0194E-01	1.1613E-05	-8.3386E-05	-4.6678E-02
-1.9742E-05	-5.4295E-05	-6.7849E-04	-4.6846E-05	-3.2491E-05	-2.9017E-06	1.1629E-05	2.8883E-05	-4.9912E-04	-1.0301E-02
1.4771E-04	8.1069E-04	2.0449E-03	7.4933E-04	5.8270E-04	7.2643E-06	-8.3706E-05	-4.9912E-04	1.0942E-02	1.1665E-01
8.8384E-02	1.1160E-01	9.3313E-01	7.9683E-02	3.1045E-02	1.7277E-02	-4.6680E-02	-1.0301E-02	1.1665E-01	7.3767E+00

KE, THE TRANSIENT ESTIMATE GAIN MATRIX

3.4190E-02	1.8369E-02	1.1899E-01	9.8504E-03
4.0804E-02	2.3405E-02	1.3311E-01	2.3425E-02
2.4738E-02	-8.5506E-02	5.9859E-02	3.1127E-02
2.8127E-02	1.6735E-02	9.0074E-02	1.7542E-02
8.1353E-03	6.2728E-03	2.4729E-02	6.4866E-03
1.4022E-04	3.5441E-03	2.4145E-02	5.0361E-05

4.8508E-03 -9.1147E-03 -5.0626E-02 3.4128E-03
 -1.3225E-06 1.3246E-04 -1.1601E-05 -6.9656E-06
 2.2205E-05 4.8406E-02 1.5395E-05 2.3014E-05
 1.8458E-03 -7.7111E-01 7.4713E-02 9.7456E-03

TIME = 0.34000E+01

RICCATI SOLUTION MATRIX

1.5872E+01	4.2321E+00	-1.7992E+00	1.7883E+00	2.2696E-01	9.4972E-03	2.7946E-01	-1.9601E-05	1.4864E-04	8.7216E-02
4.2321E+00	3.3736E+00	9.4607E-01	1.9589E+00	4.8652E-01	1.0153E-02	3.2890E-01	-5.4360E-05	8.1235E-04	1.1151E-01
-1.7903E+00	9.4608E-01	3.0020E+00	1.0059E+00	4.8306E-01	1.1372E-03	2.1756E-01	-6.7852E-04	2.0447E-03	9.3329E-01
1.7883E+00	1.9589E+00	1.0059E+00	1.3308E+00	3.5598E-01	6.7334E-03	2.2551E-01	-4.6922E-05	7.5085E-04	7.9672E-02
2.2696E-01	4.8652E-01	4.8306E-01	3.5598E-01	1.3222E-01	1.6752E-03	6.5431E-02	-3.2502E-05	5.8287E-04	3.1050E-02
9.4972E-03	1.0153E-02	1.1372E-03	6.7337E-03	1.6752E-03	5.8401E-03	-2.0222E-02	-2.9015E-06	7.2592E-06	1.7276E-02
2.7946E-01	3.2890E-01	2.1756E-01	2.2551E-01	6.5431E-02	-2.0222E-02	2.0193E-01	1.1614E-05	-8.3392E-05	-4.6681E-02
-1.9601E-05	-5.4279E-05	-6.7852E-04	-4.6840E-05	-3.2492E-05	-2.9016E-06	1.1630E-05	2.8883E-05	-4.9912E-04	-1.0301E-02
1.4752E-04	8.1063E-04	2.0449E-03	7.4929E-04	5.8268E-04	7.2641E-06	-8.3712E-05	-4.9912E-04	1.0942E-02	1.1665E-01
8.7213E-02	1.1151E-01	9.3328E-01	7.9661E-02	3.1049E-02	1.7277E-02	-4.6683E-02	-1.0301E-02	1.1665E-01	7.3767E+00

KE, THE TRANSIENT ESTIMATE GAIN MATRIX

3.3595E-02	1.8128E-02	1.1735E-01	9.0783E-03
4.0765E-02	2.3387E-02	1.3299E-01	2.3390E-02
2.4821E-02	-8.5476E-02	6.0076E-02	3.1247E-02
-2.8119E-02	1.6729E-02	9.0045E-02	1.7545E-02
8.1383E-03	6.2733E-03	2.4734E-02	6.4944E-03
1.4018E-04	3.5441E-03	2.4145E-02	5.0378E-05
4.8508E-03	-9.1154E-03	-5.0630E-02	3.4138E-03
-1.3225E-06	1.3246E-04	-1.1601E-05	-6.9656E-06
2.2205E-05	4.8406E-02	1.5395E-05	2.3013E-05
1.8458E-03	-7.7111E-01	7.4712E-02	9.7459E-03

TIME = 0.36000E+01

RICCATI SOLUTION MATRIX

1.7274E+01	4.1804E+00	-1.9796E+00	1.7620E+00	2.1264E-01	9.3507E-03	2.7443E-01	-1.9251E-05	1.4784E-04	8.5774E-02
4.1804E+00	3.3646E+00	9.5269E-01	1.9581E+00	4.8629E-01	1.0148E-02	3.2876E-01	-5.4350E-05	8.1230E-04	1.1147E-01
-1.9706E+00	9.5270E-01	3.0264E+00	1.0094E+00	4.8514E-01	1.1568E-03	2.1824E-01	-6.7855E-04	2.0448E-03	9.3349E-01
1.7620E+00	1.9581E+00	1.0094E+00	1.3308E+00	3.5614E-01	6.7331E-03	2.2551E-01	-4.6921E-05	7.5083E-04	7.9671E-02
2.1263E-01	4.8629E-01	4.8514E-01	3.5615E-01	1.3236E-01	1.6761E-03	6.5467E-02	-3.2503E-05	5.8287E-04	3.1060E-02
9.3507E-03	1.0148E-02	1.1567E-03	6.7333E-03	1.6762E-03	5.8401E-03	-2.0222E-02	-2.9015E-06	7.2591E-06	1.7276E-02
2.7443E-01	3.2875E-01	2.1824E-01	2.2551E-01	6.5466E-02	-2.0222E-02	2.0193E-01	1.1614E-05	-8.3394E-05	-4.6680E-02
-1.9311E-05	-5.4270E-05	-6.7855E-04	-4.6839E-05	-3.2493E-05	-2.9016E-06	1.1630E-05	2.8883E-05	-4.9912E-04	-1.0301E-02
1.4677E-04	8.1057E-04	2.0450E-03	7.4927E-04	5.8268E-04	7.2640E-06	-8.3715E-05	-4.9912E-04	1.0942E-02	1.1665E-01
8.5771E-02	1.1146E-01	9.3348E-01	7.9660E-02	3.1058E-02	1.7277E-02	-4.6683E-02	-1.0301E-02	1.1665E-01	7.3767E+00

KE, THE TRANSIENT ESTIMATE GAIN MATRIX

3.2917E-02	1.7832E-02	1.1536E-01	8.3825E-03
4.0747E-02	2.3378E-02	1.3293E-01	2.3383E-02
2.4913E-02	-8.5435E-02	6.0345E-02	3.1348E-02
2.8121E-02	1.6730E-02	9.0044E-02	1.7553E-02
8.1434E-03	6.2754E-03	2.4747E-02	6.5016E-03
1.4019E-04	3.5441E-03	2.4145E-02	5.0427E-05
4.8508E-03	-9.1152E-03	-5.0629E-02	3.4157E-03
-1.3225E-06	1.3246E-04	-1.1601E-05	-6.9657E-06

2.2204E-05 4.8406E-02 1.5391E-05 2.3013E-05
 1.8457E-03 -7.7111E-01 7.4712E-02 9.7464E-03

TIME = 0.38000E+01

RICCATI SOLUTION MATRIX

1.8661E+01	4.0998E+00	-2.1315E+00	1.7326E+00	2.0002E-01	9.1892E-03	2.6910E-01	-1.9065E-05	1.4669E-04	8.4213E-02
4.0998E+00	3.3591E+00	9.6277E-01	1.9581E+00	4.8647E-01	1.0148E-02	3.2877E-01	-5.4350E-05	8.1230E-04	1.1147E-01
-2.1315E+00	9.6279E-01	3.0459E+00	1.0131E+00	4.8683E-01	1.1775E-03	2.1893E-01	-6.7859E-04	2.0449E-03	9.3369E-01
1.7326E+00	1.9581E+00	1.0131E+00	1.3310E+00	3.5636E-01	6.7345E-03	2.2557E-01	-4.6923E-05	7.5085E-04	7.9685E-02
2.0002E-01	4.8647E-01	4.8683E-01	3.5637E-01	1.3248E-01	1.6774E-03	6.5509E-02	-3.2505E-05	5.8288E-04	3.1072E-02
9.1892E-03	1.0148E-02	1.1775E-03	6.7347E-03	1.6774E-03	5.8401E-03	-2.0222E-02	-2.9015E-06	7.2591E-06	1.7277E-02
2.6910E-01	3.2877E-01	2.1893E-01	2.2556E-01	6.5508E-02	-2.0222E-02	2.0195E-01	1.1613E-05	-8.3391E-05	-4.6677E-02
-1.9029E-05	-5.4269E-05	-6.7858E-04	-4.6841E-05	-3.2495E-05	-2.9016E-06	1.1630E-05	2.8883E-05	-4.9912E-04	-1.0301E-02
1.4669E-04	8.1055E-04	2.0451E-03	7.4927E-04	5.8269E-04	7.2640E-06	-8.3715E-05	-4.9912E-04	1.0942E-02	1.1665E-01
8.4213E-02	1.1147E-01	9.3368E-01	7.9674E-02	3.1070E-02	1.7277E-02	-4.6680E-02	-1.0301E-02	1.1665E-01	7.3767E+00

KE, THE TRANSIENT ESTIMATE GAIN MATRIX

3.2218E-02	1.7512E-02	1.1322E-01	7.7796E-03
4.0751E-02	2.3378E-02	1.3293E-01	2.3395E-02
2.5034E-02	-8.5394E-02	6.0621E-02	3.1429E-02
2.8129E-02	1.6732E-02	9.0064E-02	1.7565E-02
8.1491E-03	6.2779E-03	2.4764E-02	6.5077E-03
1.4023E-04	3.5441E-03	2.4145E-02	5.0489E-05
4.8522E-03	-5.1145E-03	-5.0624E-02	3.4178E-03
-1.3225E-06	1.3246E-04	-1.1601E-05	-6.9658E-06
2.2204E-05	4.8406E-02	1.5391E-05	2.3014E-05
1.8461E-03	-7.7111E-01	7.4713E-02	9.7470E-03

TIME = 0.40000E+01

RICCATI SOLUTION MATRIX

2.0022E+01	3.9948E+00	-2.2727E+00	1.7028E+00	1.8933E-01	9.0260E-03	2.6385E-01	-1.8777E-05	1.4537E-04	8.2652E-02
3.9948E+00	3.3580E+00	9.7494E-01	1.9590E+00	4.8691E-01	1.0152E-02	3.2894E-01	-5.4362E-05	8.1236E-04	1.1151E-01
-2.2727E+00	9.7495E-01	3.0610E+00	1.0167E+00	4.8813E-01	1.1969E-03	2.1956E-01	-6.7862E-04	2.0451E-03	9.3387E-01
1.7028E+00	1.9590E+00	1.0166E+00	1.3315E+00	3.5659E-01	6.7369E-03	2.2565E-01	-4.6929E-05	7.5087E-04	7.9707E-02
1.8933E-01	4.8692E-01	4.8813E-01	3.5660E-01	1.3258E-01	1.6786E-03	6.5551E-02	-3.2508E-05	5.8290E-04	3.1084E-02
9.0259E-03	1.0153E-02	1.1969E-03	6.7371E-03	1.6786E-03	5.8401E-03	-2.0222E-02	-2.9015E-06	7.2597E-06	1.7277E-02
2.6385E-01	3.2893E-01	2.1956E-01	2.2565E-01	6.5550E-02	-2.0222E-02	2.0196E-01	1.1612E-05	-8.3387E-05	-4.6673E-02
-1.8738E-05	-5.4277E-05	-6.7862E-04	-4.6845E-05	-3.2497E-05	-2.9017E-06	1.1629E-05	2.8883E-05	-4.9912E-04	-1.0301E-02
1.4438E-04	8.1057E-04	2.0452E-03	7.4928E-04	5.8270E-04	7.2641E-06	-8.3712E-05	-4.9912E-04	1.0942E-02	1.1665E-01
8.2654E-02	1.1151E-01	9.3387E-01	7.9698E-02	3.1082E-02	1.7277E-02	-4.6675E-02	-1.0301E-02	1.1665E-01	7.3767E+00

KE, THE TRANSIENT ESTIMATE GAIN MATRIX

3.1541E-02	1.7188E-02	1.1109E-01	7.2774E-03
4.0773E-02	2.3386E-02	1.3300E-01	2.3419E-02
2.5085E-02	-8.5357E-02	6.0875E-02	3.1489E-02
2.8140E-02	1.6736E-02	9.0097E-02	1.7576E-02
8.1546E-03	6.2800E-03	2.4781E-02	6.5124E-03
1.4029E-04	3.5441E-03	2.4145E-02	5.0551E-05
4.8543E-03	-5.1139E-03	-5.0618E-02	3.4198E-03
-1.3226E-06	1.3246E-04	-1.1601E-05	-6.9659E-06
2.2204E-05	4.8406E-02	1.5392E-05	2.3014E-05
1.8461E-03	-7.7111E-01	7.4713E-02	9.7470E-03

TIME = 0.42000E+01

RICCATI SOLUTION MATRIX

2.1347E+01	3.8700E+00	-2.3944E+00	1.6743E+00	1.8061E-01	8.8708E-03	2.5896E-01	-1.8494E-05	1.4411E-04	8.1183E-02
3.8700E+00	3.3613E+00	9.8807E-01	1.9605E+00	4.8749E-01	1.0161E-02	3.2921E-01	-5.4376E-05	8.1247E-04	1.1159E-01
-2.3945E+00	9.8808E-01	3.0723E+00	1.0198E+00	4.8907E-01	1.2138E-03	2.2009E-01	-6.7865E-04	2.0452E-03	9.3403E-01
1.6743E+00	1.9605E+00	1.0197E+00	1.3320E+00	3.5680E-01	6.7397E-03	2.2574E-01	-4.6534E-05	7.5093E-04	7.9733E-02
1.8061E-01	4.8750E-01	4.8907E-01	3.5680E-01	1.3265E-01	1.6797E-03	6.5586E-02	-3.2510E-05	5.8291E-04	3.1094E-02
8.8708E-03	1.0161E-02	1.2138E-03	6.7400E-03	1.6798E-03	5.8401E-03	-2.0221E-02	-2.9015E-06	7.2597E-06	1.7277E-02
2.5896E-01	3.2920E-01	2.2009E-01	2.2574E-01	6.5586E-02	-2.0221E-02	2.0198E-01	1.1611E-05	-8.3378E-05	-4.6668E-02
-1.8458E-05	-5.4291E-05	-6.7865E-04	-4.6850E-05	-3.2499E-05	-2.9017E-06	1.1628E-05	2.8883E-05	-4.9912E-04	-1.0301E-02
1.4303E-04	8.1062E-04	2.0454E-03	7.4930E-04	5.8271E-04	7.2642E-06	-8.3709E-05	-4.9912E-04	1.0942E-02	1.1665E-01
8.1183E-02	1.1159E-01	9.3402E-01	7.9725E-02	3.1093E-02	1.7277E-02	-4.6670E-02	-1.0301E-02	1.1665E-01	7.3767E+00

KE, THE TRANSIENT ESTIMATE GAIN MATRIX

3.0921E-02	1.6890E-02	1.0909E-01	6.8774E-03
4.0809E-02	2.3403E-02	1.3311E-01	2.3448E-02
2.5152E-02	-8.5323E-02	6.1091E-02	3.1533E-02
2.8152E-02	1.6742E-02	9.0134E-02	1.7586E-02
8.1592E-03	6.2824E-03	2.4795E-02	6.5158E-03
1.4036E-04	3.5442E-03	2.4145E-02	5.0604E-05
4.8564E-03	-9.1128E-03	-5.0612E-02	3.4215E-03
-1.3228E-06	1.3246E-04	-1.1601E-05	-6.9660E-06
2.2205E-05	4.8406E-02	1.5394E-05	2.3015E-05
1.8473E-03	-7.7111E-01	7.4717E-02	9.7481E-03

TIME = 0.44000E+01

RICCATI SOLUTION MATRIX

2.2628E+01	3.7293E+00	-2.4977E+00	1.6484E+00	1.7384E-01	8.7306E-03	2.5462E-01	-1.8241E-05	1.4277E-04	7.9879E-02
3.7293E+00	3.3692E+00	1.0013E+00	1.9625E+00	4.8810E-01	1.0171E-02	3.2954E-01	-5.4396E-05	8.1256E-04	1.1169E-01
-2.4977E+00	1.0013E+00	3.0805E+00	1.0223E+00	4.8972E-01	1.2274E-03	2.2051E-01	-6.7868E-04	2.0454E-03	9.3416E-01
1.6484E+00	1.9625E+00	1.0222E+00	1.3325E+00	3.5696E-01	6.7424E-03	2.2583E-01	-4.6540E-05	7.5095E-04	7.9762E-02
1.7383E-01	4.8811E-01	4.8972E-01	3.5697E-01	1.3270E-01	1.6806E-03	6.5614E-02	-3.2512E-05	5.8292E-04	3.1103E-02
8.7305E-03	1.0172E-02	1.2274E-03	6.7427E-03	1.6807E-03	5.8401E-03	-2.0221E-02	-2.9016E-06	7.2597E-06	1.7277E-02
2.5462E-01	3.2954E-01	2.2051E-01	2.2583E-01	6.5614E-02	-2.0221E-02	2.0199E-01	1.1610E-05	-8.3374E-05	-4.6663E-02
-1.8202E-05	-5.4310E-05	-6.7867E-04	-4.6855E-05	-3.2501E-05	-2.9017E-06	1.1627E-05	2.8883E-05	-4.9912E-04	-1.0301E-02
1.4170E-04	8.1071E-04	2.0455E-03	7.4932E-04	5.8272E-04	7.2643E-06	-8.3705E-05	-4.9912E-04	1.0942E-02	1.1665E-01
7.9879E-02	1.1169E-01	9.3415E-01	7.9751E-02	3.1102E-02	1.7277E-02	-4.6666E-02	-1.0301E-02	1.1665E-01	7.3767E+00

KE, THE TRANSIENT ESTIMATE GAIN MATRIX

3.0377E-02	1.6620E-02	1.0731E-01	6.5758E-03
4.0851E-02	2.3424E-02	1.3324E-01	2.3477E-02
2.5205E-02	-8.5297E-02	6.1265E-02	3.1561E-02
2.8163E-02	1.6748E-02	9.0170E-02	1.7593E-02
8.1627E-03	6.2841E-03	2.4807E-02	6.5180E-03
1.4042E-04	3.5442E-03	2.4145E-02	5.0646E-05
4.8583E-03	-9.1118E-03	-5.0605E-02	3.4228E-03
-1.3229E-06	1.3246E-04	-1.1602E-05	-6.9661E-06
2.2205E-05	4.8406E-02	1.5395E-05	2.3015E-05
1.8479E-03	-7.7111E-01	7.4719E-02	9.7485E-03

TIME = 0.46000E+01

RICCATI SOLUTION MATRIX

2.3858E+01	3.5765E+00	-2.5836E+00	1.6261E+00	1.6887E-01	8.6094E-03	2.5094E-01	-1.8022E-05	1.4148E-04	7.8730E-02
3.5764E+00	3.3814E+00	1.0140E+00	1.9646E+00	4.8867E-01	1.0183E-02	3.2990E-01	-5.4421E-05	8.1269E-04	1.1180E-01
-2.5836E+00	1.0140E+00	3.0861E+00	1.0242E+00	4.9013E-01	1.2378E-03	2.2082E-01	-6.7870E-04	2.0455E-03	9.3425E-01
1.6261E+00	1.9646E+00	1.0242E+00	1.3329E+00	3.5708E-01	6.7448E-03	2.2590E-01	-4.6946E-05	7.5099E-04	7.9781E-02
1.6887E-01	4.8867E-01	4.9013E-01	3.5708E-01	1.3273E-01	1.6813E-03	6.5634E-02	-3.2513E-05	5.8293E-04	3.1109E-02
8.6094E-03	1.0183E-02	1.2378E-03	6.7451E-03	1.6813E-03	5.8401E-03	-2.0220E-02	-2.9016E-06	7.2604E-06	1.7277E-02
2.5094E-01	3.2990E-01	2.2082E-01	2.2590E-01	6.5634E-02	-2.0220E-02	2.0200E-01	1.1609E-05	-8.3369E-05	-4.6660E-02
-1.7979E-05	-5.4331E-05	-6.7869E-04	-4.6860E-05	-3.2502E-05	-2.9017E-06	1.1626E-05	2.8883E-05	-4.9912E-04	-1.0301E-02
1.4048E-04	8.1082E-04	2.0456E-03	7.4934E-04	5.8272E-04	7.2644E-06	-8.3701E-05	-4.9912E-04	1.0942E-02	1.1665E-01
7.8748E-02	1.1180E-01	9.3425E-01	7.9773E-02	3.1108E-02	1.7277E-02	-4.6662E-02	-1.0301E-02	1.1665E-01	7.3767E+00

KE, THE TRANSIENT ESTIMATE GAIN MATRIX

2.9922E-02	1.6377E-02	1.0578E-01	6.3654E-03
4.0896E-02	2.3444E-02	1.3339E-01	2.3503E-02
2.5243E-02	-8.5277E-02	6.1395E-02	3.1578E-02
2.8172E-02	1.6751E-02	9.0200E-02	1.7599E-02
8.1652E-03	6.2851E-03	2.4815E-02	6.5193E-03
1.4047E-04	3.5442E-03	2.4146E-02	5.0675E-05
4.8599E-03	-9.1112E-03	-5.0600E-02	3.4237E-03
-1.3230E-06	1.3246E-04	-1.1602E-05	-6.9661E-06
2.2206E-05	4.8406E-02	1.5397E-05	2.3015E-05
1.8484E-03	-7.7111E-01	7.4720E-02	9.7488E-03

TIME = 0.48000E+01

RICCATI SOLUTION MATRIX

2.5031E+01	3.4147E+00	-2.6536E+00	1.6077E+00	1.6556E-01	8.5096E-03	2.4797E-01	-1.7826E-05	1.4038E-04	7.7829E-02
3.4147E+00	3.3976E+00	1.0257E+00	1.9667E+00	4.8913E-01	1.0194E-02	3.3025E-01	-5.4439E-05	8.1281E-04	1.1191E-01
-2.6536E+00	1.0257E+00	3.0898E+00	1.0255E+00	4.9036E-01	1.2452E-03	2.2104E-01	-6.7871E-04	2.0456E-03	9.3432E-01
1.6077E+00	1.9667E+00	1.0255E+00	1.3333E+00	3.5716E-01	6.7467E-03	2.2596E-01	-4.6948E-05	7.5101E-04	7.9800E-02
1.6556E-01	4.8914E-01	4.9036E-01	3.5716E-01	1.3275E-01	1.6817E-03	6.5647E-02	-3.2514E-05	5.8293E-04	3.1113E-02
8.5096E-03	1.0194E-02	1.2452E-03	6.7469E-03	1.6817E-03	5.8401E-03	-2.0220E-02	-2.9016E-06	7.2602E-06	1.7277E-02
2.4797E-01	3.3024E-01	2.2104E-01	2.2596E-01	6.5646E-02	-2.0220E-02	2.0201E-01	1.1609E-05	-8.3365E-05	-4.6657E-02
-1.7793E-05	-5.4352E-05	-6.7871E-04	-4.6863E-05	-3.2503E-05	-2.9018E-06	1.1626E-05	2.8883E-05	-4.9912E-04	-1.0301E-02
1.3941E-04	8.1093E-04	2.0457E-03	7.4936E-04	5.8273E-04	7.2645E-06	-8.3698E-05	-4.9912E-04	1.0942E-02	1.1665E-01
7.7828E-02	1.1191E-01	9.3432E-01	7.9791E-02	3.1112E-02	1.7277E-02	-4.6659E-02	-1.0301E-02	1.1665E-01	7.3767E+00

KE, THE TRANSIENT ESTIMATE GAIN MATRIX

2.9560E-02	1.6198E-02	1.0454E-01	6.2368E-03
4.0939E-02	2.3468E-02	1.3353E-01	2.3523E-02
2.5270E-02	-8.5264E-02	6.1487E-02	3.1586E-02
2.8179E-02	1.6756E-02	9.0224E-02	1.7602E-02
8.1668E-03	6.2861E-03	2.4820E-02	6.5200E-03
1.4051E-04	3.5442E-03	2.4146E-02	5.0694E-05
4.8610E-03	-9.1105E-03	-5.0596E-02	3.4243E-03
-1.3230E-06	1.3246E-04	-1.1602E-05	-6.9661E-06
2.2206E-05	4.8406E-02	1.5398E-05	2.3015E-05
1.8487E-03	-7.7111E-01	7.4721E-02	9.7489E-03

TIME = 0.50000E+01

RICCATI SOLUTION MATRIX

2.6144E+01	3.2471E+00	-2.7092E+00	1.5933E+00	1.6368E-01	8.4314E-03	2.4569E-01	-1.7671E-05	1.3927E-04	7.7115E-02
3.2471E+00	3.4174E+00	1.0361E+00	1.9687E+00	4.8947E-01	1.0205E-02	3.3056E-01	-5.4452E-05	8.1280E-04	1.1201E-01
-2.7092E+00	1.0361E+00	3.0919E+00	1.0264E+00	4.9045E-01	1.2501E-03	2.2118E-01	-6.7872E-04	2.0456E-03	9.3437E-01
1.5933E+00	1.9687E+00	1.0264E+00	1.3335E+00	3.5721E-01	6.7480E-03	2.2600E-01	-4.6946E-05	7.5094E-04	7.9814E-02
1.6368E-01	4.8947E-01	4.9045E-01	3.5721E-01	1.3275E-01	1.6820E-03	6.5654E-02	-3.2513E-05	5.8292E-04	3.1116E-02
8.4314E-03	1.0205E-02	1.2501E-03	6.7483E-03	1.6820E-03	5.8402E-03	-2.0220E-02	-2.9016E-06	7.2599E-06	1.7277E-02
2.4569E-01	3.3056E-01	2.2118E-01	2.2600E-01	6.5654E-02	-2.0220E-02	2.0202E-01	1.1609E-05	-8.3375E-05	-4.6655E-02
-1.7645E-05	-5.4371E-05	-6.7872E-04	-4.6866E-05	-3.2503E-05	-2.9018E-06	1.1625E-05	2.8883E-05	-4.9912E-04	-1.0301E-02
1.3927E-04	8.1104E-04	2.0458E-03	7.4938E-04	5.8273E-04	7.2647E-06	-8.3696E-05	-4.9912E-04	1.0942E-02	1.1665E-01
7.7116E-02	1.1200E-01	9.3436E-01	7.9803E-02	3.1114E-02	1.7277E-02	-4.6657E-02	-1.0301E-02	1.1665E-01	7.3767E+00

KF, THE TRANSIENT ESTIMATE GAIN MATRIX

2.9290E-02	1.6050E-02	1.0358E-01	6.1794E-03
4.0777E-02	2.3489E-02	1.3366E-01	2.3536E-02
2.5286E-02	-8.5253E-02	6.1546E-02	3.1589E-02
2.8184E-02	1.6759E-02	9.0240E-02	1.7604E-02
8.1677E-03	6.2869E-03	2.4823E-02	6.5202E-03
1.4053E-04	3.5443E-03	2.4146E-02	5.0704E-05
4.8618E-03	-9.1099E-03	-5.0594E-02	3.4246E-03
-1.3231E-06	1.3245E-04	-1.1603E-05	-6.9662E-06
2.2206E-05	4.8406E-02	1.5399E-05	2.3015E-05
1.8490E-03	-7.7111E-01	7.4722E-02	9.7490E-03

TIME = 0.52000E+01

RICCATI SOLUTION MATRIX

2.7193E+01	3.0761E+00	-2.7520E+00	1.5829E+00	1.6303E-01	8.3744E-03	2.4409E-01	-1.7560E-05	1.3850E-04	7.6603E-02
3.0761E+00	3.4403E+00	1.0451E+00	1.9703E+00	4.8965E-01	1.0213E-02	3.3081E-01	-5.4469E-05	8.1291E-04	1.1208E-01
-2.7520E+00	1.0451E+00	3.0928E+00	1.0270E+00	4.9046E-01	1.2530E-03	2.2126E-01	-6.7872E-04	2.0457E-03	9.3439E-01
1.5829E+00	1.9703E+00	1.0269E+00	1.3337E+00	3.5723E-01	6.7489E-03	2.2603E-01	-4.6949E-05	7.5096E-04	7.9823E-02
1.6303E-01	4.8966E-01	4.9046E-01	3.5723E-01	1.3275E-01	1.6821E-03	6.5658E-02	-3.2514E-05	5.8292E-04	3.1117E-02
8.3744E-03	1.0214E-02	1.2530E-03	6.7491E-03	1.6821E-03	5.8402E-03	-2.0220E-02	-2.9016E-06	7.2599E-06	1.7277E-02
2.4409E-01	3.3080E-01	2.2126E-01	2.2602E-01	6.5657E-02	-2.0220E-02	2.0202E-01	1.1609E-05	-8.3372E-05	-4.6653E-02
-1.7536E-05	-5.4388E-05	-6.7872E-04	-4.6867E-05	-3.2503E-05	-2.9018E-06	1.1625E-05	2.8883E-05	-4.9912E-04	-1.0301E-02
1.3779E-04	8.1114E-04	2.0458E-03	7.4939E-04	5.8273E-04	7.2647E-06	-8.3695E-05	-4.9912E-04	1.0942E-02	1.1665E-01
7.6604E-02	1.1208E-01	9.3439E-01	7.9811E-02	3.1115E-02	1.7277E-02	-4.6656E-02	-1.0301E-02	1.1665E-01	7.3767E+00

KE, THE TRANSIENT ESTIMATE GAIN MATRIX

2.9105E-02	1.5944E-02	1.0289E-01	6.1823E-03
4.1077E-02	2.3505E-02	1.3377E-01	2.3541E-02
2.5295E-02	-8.5248E-02	6.1581E-02	3.1587E-02
2.8187E-02	1.6761E-02	9.0251E-02	1.7605E-02
8.1680E-03	6.2871E-03	2.4825E-02	6.5202E-03
1.4055E-04	3.5443E-03	2.4146E-02	5.0707E-05
4.8623E-03	-9.1096E-03	-5.0592E-02	3.4247E-03
-1.3231E-06	1.3246E-04	-1.1603E-05	-6.9662E-06
2.2206E-05	4.8406E-02	1.5400E-05	2.3016E-05
1.8491E-03	-7.7111E-01	7.4723E-02	9.7491E-03

TIME = 0.54000E+01

RICCATI SOLUTION MATRIX

2.8175E+01	2.9040E+00	-2.7835E+00	1.5761E+00	1.6340E-01	8.3368E-03	2.4310E-01	-1.7486E-05	1.3796E-04	7.6273E-02
------------	------------	-------------	------------	------------	------------	------------	-------------	------------	------------

2.9040E+00	3.4660E+00	1.0526E+00	1.9715E+00	4.8969E-01	1.0220E-02	3.3099E-01	-5.4482E-05	8.1298E-04	1.1214E-01
-2.7835E+00	1.0526E+00	3.0930E+00	1.0272E+00	4.9041E-01	1.2544E-03	2.2130E-01	-6.7873E-04	2.0457E-03	9.3440E-01
1.5761E+00	1.9715E+00	1.0272E+00	1.3337E+00	3.5723E-01	6.7494E-03	2.2604E-01	-4.6550E-05	7.5095E-04	7.9826E-02
1.6340E-01	4.8969E-01	4.9041E-01	3.5724E-01	1.3275E-01	1.6821E-03	6.5658E-02	-3.2514E-05	5.8292E-04	3.1117E-02
8.3368E-03	1.0220E-02	1.2544E-03	6.7496E-03	1.6821E-03	5.8402E-03	-2.0220E-02	-2.9016E-06	7.2599E-06	1.7277E-02
2.4310E-01	3.3099E-01	2.2129E-01	2.2604E-01	6.5658E-02	-2.0220E-02	2.0203E-01	1.1609E-05	-8.3374E-05	-4.6653E-02
-1.7462E-05	-5.4400E-05	-6.7872E-04	-4.6868E-05	-3.2503E-05	-2.9018E-06	1.1625E-05	2.8883E-05	-4.9912E-04	-1.0301E-02
1.3724E-14	8.1123E-04	2.0458E-03	7.4939E-04	5.8273E-04	7.2647E-06	-8.3693E-05	-4.9912E-04	1.0942E-02	1.1665E-01
7.6276E-02	1.1214E-01	9.3440E-01	7.9815E-02	3.1115E-02	1.7277E-02	-4.6655E-02	-1.0301E-02	1.1665E-01	7.3767E+00

KE, THE TRANSIENT ESTIMATE GAIN MATRIX

2.8998E-02	1.5876E-02	1.0246E-01	6.2348E-03
4.1027E-02	2.3517E-02	1.3385E-01	2.3537E-02
2.5299E-02	-8.5246E-02	6.1596E-02	3.1583E-02
2.8189E-02	1.6761E-02	9.0257E-02	1.7695E-02
8.1681E-03	6.2870E-03	2.4825E-02	6.5202E-03
1.4056E-04	3.5443E-03	2.4146E-02	5.0707E-05
4.8625E-03	-9.1096E-03	-5.0591E-02	3.4247E-03
-1.3231E-06	1.3245E-04	-1.1603E-05	-6.9662E-06
2.2207E-05	4.8406E-02	1.5400E-05	2.3016E-05
1.8492E-03	-7.7111E-01	7.4723E-02	9.7491E-03

TIME = 0.56000E+01

RICCATI SOLUTION MATRIX

2.9091E+01	2.7328E+00	-2.8053E+00	1.5727E+00	1.6460E-01	8.3168E-03	2.4266E-01	-1.7441E-05	1.3757E-04	7.6110E-02
2.7328E+00	3.4940E+00	1.0585E+00	1.9722E+00	4.8957E-01	1.0224E-02	3.3110E-01	-5.4490E-05	8.1306E-04	1.1218E-01
-2.8053E+00	1.0585E+00	3.0927E+00	1.0273E+00	4.9033E-01	1.2547E-03	2.2130E-01	-6.7873E-04	2.0457E-03	9.3441E-01
1.5727E+00	1.9722E+00	1.0272E+00	1.3338E+00	3.5723E-01	6.7496E-03	2.2605E-01	-4.6550E-05	7.5096E-04	7.9828E-02
1.6459E-11	4.8958E-01	4.9033E-01	3.5723E-01	1.3275E-01	1.6821E-03	6.5658E-02	-3.2514E-05	5.8292E-04	3.1117E-02
8.3168E-03	1.0224E-02	1.2547E-03	6.7499E-03	1.6821E-03	5.8402E-03	-2.0219E-02	-2.9016E-06	7.2599E-06	1.7277E-02
2.4266E-01	3.3109E-01	2.2130E-01	2.2604E-01	6.5657E-02	-2.0220E-02	2.0203E-01	1.1609E-05	-8.3373E-05	-4.6653E-02
-1.7420E-05	-5.4409E-05	-6.7873E-04	-4.6869E-05	-3.2503E-05	-2.9018E-06	1.1625E-05	2.8883E-05	-4.9912E-04	-1.0301E-02
1.3686E-04	8.1129E-04	2.0458E-03	7.4940E-04	5.8273E-04	7.2648E-06	-8.3693E-05	-4.9912E-04	1.0942E-02	1.1665E-01
7.6113E-02	1.1218E-01	9.3440E-01	7.9817E-02	3.1115E-02	1.7277E-02	-4.6655E-02	-1.0301E-02	1.1665E-01	7.3767E+00

KF, THE TRANSIENT ESTIMATE GAIN MATRIX

2.8960E-02	1.5844E-02	1.0225E-01	6.3271E-03
4.1038E-02	2.3525E-02	1.3390E-01	2.3527E-02
2.5298E-02	-8.5246E-02	6.1599E-02	3.1578E-02
2.8189E-02	1.6762E-02	9.0259E-02	1.7604E-02
8.1681E-03	6.2870E-03	2.4825E-02	6.5202E-03
1.4056E-04	3.5443E-03	2.4146E-02	5.0706E-05
4.8626E-03	-9.1095E-03	-5.0591E-02	3.4246E-03
-1.3231E-06	1.3246E-04	-1.1603E-05	-6.9662E-06
2.2207E-05	4.8406E-02	1.5401E-05	2.3016E-05
1.8492E-03	-7.7111E-01	7.4723E-02	9.7490E-03

TIME = 0.58000E+01

RICCATI SOLUTION MATRIX

2.9938E+01	2.5640E+00	-2.8187E+00	1.5720E+00	1.6644E-01	8.3119E-03	2.4268E-01	-1.7426E-05	1.3728E-04	7.6088E-02
2.5640E+00	3.5239E+00	1.0630E+00	1.9725E+00	4.8933E-01	1.0226E-02	3.3113E-01	-5.4495E-05	8.1311E-04	1.1219E-01
-2.8187E+00	1.0630E+00	3.0920E+00	1.0272E+00	4.9024E-01	1.2544E-03	2.2128E-01	-6.7873E-04	2.0457E-03	9.3440E-01

1.5720E+00	1.9725E+00	1.0272E+00	1.3338E+00	3.5723E-01	6.7496E-03	2.2605E-01	-4.6950E-05	7.5096E-04	7.9828E-02
1.6643E-01	4.8933E-01	4.9024E-01	3.5723E-01	1.3275E-01	1.6821E-03	6.5657E-02	-3.2514E-05	5.3292E-04	3.1116E-02
8.3119E-03	1.0226E-02	1.2544E-03	6.7499E-03	1.6821E-03	5.8402E-03	-2.0219E-02	-2.9016E-06	7.2600E-06	1.7277E-02
2.4268E-01	3.3112E-01	2.2128E-01	2.2694E-01	6.5656E-02	-2.0220E-02	2.0203E-01	1.1609E-05	-8.3373E-05	-4.6653E-02
-1.7409E-05	-5.4413E-05	-6.7873E-04	-4.6889E-05	-3.2503E-05	-2.9018E-06	1.1625E-05	2.8883E-05	-4.9912E-04	-1.0301E-02
1.3663E-04	8.1134E-04	2.0459E-03	7.4940E-04	5.8273E-04	7.2647E-06	-8.3693E-05	-4.9912E-04	1.0942E-02	1.1665E-01
7.6091E-02	1.1219E-01	9.3440E-01	7.9818E-02	3.1115E-02	1.7277E-02	-4.6655E-02	-1.0301E-02	1.1665E-01	7.3767E+00

KE, THE TRANSIENT ESTIMATE GAIN MATRIX

2.8980E-02	1.5838E-02	1.0223E-01	6.4499E-03
4.1039E-02	2.3527E-02	1.3391E-01	2.3509E-02
2.5296E-02	-8.5247E-02	6.1593E-02	3.1572E-02
2.8189E-02	1.6762E-02	9.0260E-02	1.7604E-02
8.1680E-03	6.2868E-03	2.4825E-02	6.5202E-03
1.4056E-04	3.5443E-03	2.4146E-02	5.0704E-05
4.8626E-03	-9.1096E-03	-5.0591E-02	3.4246E-03
-1.3231E-06	1.3245E-04	-1.1603E-05	-6.9662E-06
2.2207E-05	4.8406E-02	1.5401E-05	2.3016E-05
1.8492E-03	-7.7111E-01	7.4723E-02	9.7490E-03

TIME = 0.60000E+01

RICCATI SOLUTION MATRIX

3.0719E+01	2.3992E+00	-2.8249E+00	1.5738E+00	1.6876E-01	8.3197E-03	2.4308E-01	-1.7436E-05	1.3719E-04	7.6184E-02
2.3992E+00	3.5554E+00	1.0660E+00	1.9724E+00	4.8896E-01	1.0226E-02	3.3108E-01	-5.4495E-05	8.1314E-04	1.1219E-01
-2.8249E+00	1.0660E+00	3.0912E+00	1.0271E+00	4.9017E-01	1.2538E-03	2.2126E-01	-6.7873E-04	2.0457E-03	9.3440E-01
1.5738E+00	1.9724E+00	1.0271E+00	1.3338E+00	3.5722E-01	6.7496E-03	2.2605E-01	-4.6950E-05	7.5096E-04	7.9830E-02
1.6876E-01	4.8896E-01	4.9016E-01	3.5723E-01	1.3276E-01	1.6820E-03	6.5657E-02	-3.2513E-05	5.8292E-04	3.1117E-02
8.3197E-03	1.0226E-02	1.2538E-03	6.7499E-03	1.6821E-03	5.8402E-03	-2.0219E-02	-2.9016E-06	7.2599E-06	1.7277E-02
2.4268E-01	3.3108E-01	2.2126E-01	2.2604E-01	6.5656E-02	-2.0220E-02	2.0203E-01	1.1609E-05	-8.3373E-05	-4.6652E-02
-1.7415E-05	-5.4413E-05	-6.7872E-04	-4.6889E-05	-3.2503E-05	-2.9018E-06	1.1625E-05	2.8883E-05	-4.9912E-04	-1.0301E-02
1.3662E-04	8.1137E-04	2.0458E-03	7.4940E-04	5.8273E-04	7.2647E-06	-8.3693E-05	-4.9912E-04	1.0942E-02	1.1665E-01
7.6187E-02	1.1218E-01	9.3439E-01	7.9818E-02	3.1115E-02	1.7277E-02	-4.6655E-02	-1.0301E-02	1.1665E-01	7.3767E+00

KE, THE TRANSIENT ESTIMATE GAIN MATRIX

2.9048E-02	1.5858E-02	1.0237E-01	6.5955E-03
4.1031E-02	2.3526E-02	1.3390E-01	2.3485E-02
2.5292E-02	-8.5247E-02	6.1584E-02	3.1568E-02
2.8189E-02	1.6762E-02	9.0260E-02	1.7604E-02
8.1680E-03	6.2870E-03	2.4824E-02	6.5204E-03
1.4056E-04	3.5443E-03	2.4146E-02	5.0703E-05
4.8626E-03	-9.1094E-03	-5.0591E-02	3.4246E-03
-1.3231E-06	1.3246E-04	-1.1603E-05	-6.9662E-06
2.2207E-05	4.8406E-02	1.5400E-05	2.3015E-05
1.8492E-03	-7.7111E-01	7.4723E-02	9.7490E-03

TIME = 0.62000E+01

RICCATI SOLUTION MATRIX

3.1433E+01	2.2395E+00	-2.8252E+00	1.5775E+00	1.7143E-01	8.3379E-03	2.4380E-01	-1.7465E-05	1.3718E-04	7.6376E-02
2.2395E+00	3.5879E+00	1.0676E+00	1.9718E+00	4.8848E-01	1.0223E-02	3.3097E-01	-5.4493E-05	8.1318E-04	1.1216E-01
-2.8252E+00	1.0677E+00	3.0904E+00	1.0269E+00	4.9010E-01	1.2531E-03	2.2124E-01	-6.7873E-04	2.0457E-03	9.3439E-01
1.5775E+00	1.9718E+00	1.0269E+00	1.3338E+00	3.5723E-01	6.7497E-03	2.2605E-01	-4.6951E-05	7.5098E-04	7.9829E-02
1.7143E-01	4.8848E-01	4.9010E-01	3.5723E-01	1.3276E-01	1.6821E-03	6.5658E-02	-3.2514E-05	5.8292E-04	3.1116E-02

8.3379E-03	1.0223E-02	1.2531E-03	6.7499E-03	1.6821E-03	5.8402E-03	-2.0219E-02	-2.9C16E-06	7.2600E-06	1.7277E-02
2.4380E-01	3.3097E-01	2.2123E-01	2.2604E-01	6.5657E-02	-2.0220E-02	2.0203E-01	1.1609E-05	-8.3369E-05	-4.6653E-02
-1.7444E-05	-5.4409E-05	-6.7872E-04	-4.6869E-05	-3.2503E-05	-2.9018E-06	1.1625E-05	2.8883E-05	-4.9912E-04	-1.0301E-02
1.3653E-04	8.1137E-04	2.0458E-03	7.4940E-04	5.8273E-04	7.2647E-06	-8.3693E-05	-4.9912E-04	1.0942E-02	1.1665E-01
7.6379E-02	1.1215E-01	9.3438E-01	7.9818E-02	3.1115E-02	1.7277E-02	-4.6655E-02	-1.0301E-02	1.1665E-01	7.3767E+00

KE, THE TRANSIENT ESTIMATE GAIN MATRIX

2.9155E-02	1.5896E-02	1.0264E-01	6.7567E-03
4.1013E-02	2.3520E-02	1.3386E-01	2.3456E-02
2.5289E-02	-8.5249E-02	6.1575E-02	3.1564E-02
2.8190E-02	1.6762E-02	9.0260E-02	1.7604E-02
8.1682E-03	6.2869E-03	2.4825E-02	6.5207E-03
1.4056E-04	3.5443E-03	2.4146E-02	5.0704E-05
4.8627E-03	-9.1095E-03	-5.0591E-02	3.4247E-03
-1.3231E-06	1.3246E-04	-1.1603E-05	-6.9662E-06
2.2207E-05	4.8406E-02	1.5401E-05	2.3015E-05
1.8492E-03	-7.7111E-01	7.4723E-02	5.7490E-03

TIME = 0.64000E+01

RICCATI SOLUTION MATRIX

3.2084E+01	2.0859E+00	-2.8205E+00	1.5828E+00	1.7432E-01	8.3643E-03	2.4477E-01	-1.7506E-05	1.3725E-04	7.6644E-02
2.0859E+00	3.6213E+00	1.0681E+00	1.9709E+00	4.8792E-01	1.0218E-02	3.3079E-01	-5.4484E-05	8.1315E-04	1.1211E-01
-2.8205E+00	1.0681E+00	3.0896E+00	1.0267E+00	4.9006E-01	1.2525E-03	2.2122E-01	-6.7872E-04	2.0457E-03	9.3438E-01
1.5828E+00	1.9709E+00	1.0267E+00	1.3338E+00	3.5724E-01	6.7497E-03	2.2605E-01	-4.6950E-05	7.5096E-04	7.9830E-02
1.7432E-01	4.8792E-01	4.9006E-01	3.5724E-01	1.3277E-01	1.6821E-03	6.5660E-02	-3.2514E-05	5.8292E-04	3.1117E-02
8.3643E-03	1.0218E-02	1.2525E-03	6.7500E-03	1.6821E-03	5.8402E-03	-2.0219E-02	-2.9016E-06	7.2600E-06	1.7277E-02
2.4477E-01	3.3079E-01	2.2122E-01	2.2605E-01	6.5659E-02	-2.0220E-02	2.0203E-01	1.1609E-05	-8.3372E-05	-4.6652E-02
-1.7488E-05	-5.4401E-05	-6.7872E-04	-4.6869E-05	-3.2503E-05	-2.9018E-06	1.1625E-05	2.8883E-05	-4.9912E-04	-1.0301E-02
1.3663E-04	8.1136E-04	2.0458E-03	7.4940E-04	5.8273E-04	7.2648E-06	-8.3693E-05	-4.9912E-04	1.0942E-02	1.1665E-01
7.6647E-02	1.1210E-01	9.3438E-01	7.9819E-02	3.1115E-02	1.7277E-02	-4.6655E-02	-1.0301E-02	1.1665E-01	7.3767E+00

KF, THE TRANSIENT ESTIMATE GAIN MATRIX

2.9291E-02	1.5953E-02	1.0301E-01	6.9279E-03
4.0988E-02	2.3510E-02	1.3379E-01	2.3422E-02
2.5286E-02	-8.5251E-02	6.1567E-02	3.1562E-02
2.8190E-02	1.6762E-02	9.0261E-02	1.7605E-02
8.1685E-03	6.2870E-03	2.4826E-02	6.5212E-03
1.4056E-04	3.5443E-03	2.4146E-02	5.0708E-05
4.8628E-03	-9.1095E-03	-5.0591E-02	3.4248E-03
-1.3231E-06	1.3246E-04	-1.1603E-05	-6.9662E-06
2.2207E-05	4.8406E-02	1.5401E-05	2.3015E-05
1.8493E-03	-7.7111E-01	7.4723E-02	5.7491E-03

TIME = 0.66000E+01

RICCATI SOLUTION MATRIX

3.2672E+01	1.9393E+00	-2.8119E+00	1.5892E+00	1.7735E-01	8.3969E-03	2.4591E-01	-1.7562E-05	1.3740E-04	7.6967E-02
1.9393E+00	3.6550E+00	1.0674E+00	1.9696E+00	4.8728E-01	1.0212E-02	3.3056E-01	-5.4473E-05	8.1313E-04	1.1204E-01
-2.8119E+00	1.0674E+00	3.0890E+00	1.0267E+00	4.9004E-01	1.2521E-03	2.2120E-01	-6.7872E-04	2.0457E-03	9.3438E-01
1.5892E+00	1.9696E+00	1.0267E+00	1.3339E+00	3.5726E-01	6.7499E-03	2.2606E-01	-4.6951E-05	7.5097E-04	7.9832E-02
1.7735E-01	4.8728E-01	4.9004E-01	3.5726E-01	1.3278E-01	1.6822E-03	6.5664E-02	-3.2514E-05	5.8292E-04	3.1118E-02
8.3969E-03	1.0212E-02	1.2521E-03	6.7502E-03	1.6822E-03	5.8402E-03	-2.0219E-02	-2.9016E-06	7.2599E-06	1.7277E-02
2.4591E-01	3.3056E-01	2.2120E-01	2.2605E-01	6.5663E-02	-2.0219E-02	2.0203E-01	1.1609E-05	-8.3371E-05	-4.6652E-02

-1.7544E-05	-5.4390E-05	-6.7872E-04	-4.6869E-05	-3.2504E-05	-2.9018E-06	1.1625E-05	2.8883E-05	-4.9912E-04	-1.0301E-02
1.3680E-04	8.1133E-04	2.0458E-03	7.4940E-04	5.8273E-04	7.2647E-06	-8.3693E-05	-4.9912E-04	1.0942E-02	1.1665E-01
7.6971E-02	1.1204E-01	9.3437E-01	7.9821E-02	3.1116E-02	1.7277E-02	-4.6654E-02	-1.0301E-02	1.1665E-01	7.3767E+00

KE, THE TRANSIENT ESTIMATE GAIN MATRIX

2.9449E-02	1.6018E-02	1.0346E-01	7.1039E-03
4.0956E-02	2.3497E-02	1.3370E-01	2.3384E-02
2.5285E-02	-8.5251E-02	6.1562E-02	3.1561E-02
2.8191E-02	1.6763E-02	9.0264E-02	1.7606E-02
8.1690E-03	6.2873E-03	2.4827E-02	6.5219E-03
1.4057E-04	3.5443E-03	2.4146E-02	5.0714E-05
4.8629E-03	-9.1094E-03	-5.0590E-02	3.4250E-03
-1.3231E-06	1.3246E-04	-1.1603E-05	-6.9662E-06
2.2207E-05	4.8406E-02	1.5401E-05	2.3015E-05
1.8493E-03	-7.7111E-01	7.4723E-02	5.7491E-03

TIME = 0.68000E+01

RICCATI SOLUTION MATRIX

3.3201E+01	1.8001E+00	-2.8000E+00	1.5965E+00	1.8042E-01	8.4339E-03	2.4718E-01	-1.7626E-05	1.3763E-04	7.7330E-02
1.8001E+00	3.6890E+00	1.0657E+00	1.9680E+00	4.8659E-01	1.0204E-02	3.3029E-01	-5.4459E-05	8.1309E-04	1.1196E-01
-2.8000E+00	1.0657E+00	3.0885E+00	1.0267E+00	4.9005E-01	1.2520E-03	2.2120E-01	-6.7872E-04	2.0457E-03	9.3438E-01
1.5965E+00	1.9680E+00	1.0267E+00	1.3339E+00	3.5729E-01	6.7502E-03	2.2607E-01	-4.6951E-05	7.5097E-04	7.9835E-02
1.8042E-01	4.8659E-01	4.9005E-01	3.5729E-01	1.3279E-01	1.6824E-03	6.5669E-02	-3.2514E-05	5.8292E-04	3.1120E-02
8.4339E-03	1.0204E-02	1.2520E-03	6.7505E-03	1.6824E-03	5.8402E-03	-2.0219E-02	-2.9016E-06	7.2598E-06	1.7277E-02
2.4718E-01	3.3028E-01	2.2120E-01	2.2606E-01	6.5668E-02	-2.0219E-02	2.0203E-01	1.1609E-05	-8.3370E-05	-4.6651E-02
-1.7608E-05	-5.4377E-05	-6.7872E-04	-4.6870E-05	-3.2504E-05	-2.9018E-06	1.1625E-05	2.8883E-05	-4.9912E-04	-1.0301E-02
1.3703E-04	8.1128E-04	2.0458E-03	7.4940E-04	5.8273E-04	7.2647E-06	-8.3692E-05	-4.9912E-04	1.0942E-02	1.1665E-01
7.7335E-02	1.1196E-01	9.3437E-01	7.9824E-02	3.1118E-02	1.7277E-02	-4.6654E-02	-1.0301E-02	1.1665E-01	7.3767E+00

KE, THE TRANSIENT ESTIMATE GAIN MATRIX

2.9621E-02	1.6093E-02	1.0396E-01	7.2809E-03
4.0918E-02	2.3481E-02	1.3359E-01	2.3344E-02
2.5285E-02	-8.5250E-02	6.1561E-02	3.1562E-02
2.8192E-02	1.6763E-02	9.0268E-02	1.7608E-02
8.1697E-03	6.2877E-03	2.4829E-02	6.5226E-03
1.4058E-04	3.5443E-03	2.4146E-02	5.0722E-05
4.8632E-03	-9.1092E-03	-5.0589E-02	3.4253E-03
-1.3232E-06	1.3246E-04	-1.1603E-05	-6.9662E-06
2.2207E-05	4.8406E-02	1.5401E-05	2.3016E-05
1.8494E-03	-7.7111E-01	7.4724E-02	5.7492E-03

TIME = 0.70000E+01

RICCATI SOLUTION MATRIX

3.3673E+01	1.6691E+00	-2.7857E+00	1.6043E+00	1.8348E-01	8.4737E-03	2.4852E-01	-1.7695E-05	1.3784E-04	7.7719E-02
1.6690E+00	3.7228E+00	1.0631E+00	1.9662E+00	4.8585E-01	1.0194E-02	3.2997E-01	-5.4443E-05	8.1301E-04	1.1187E-01
-2.7857E+00	1.0631E+00	3.0882E+00	1.0268E+00	4.9008E-01	1.2523E-03	2.2121E-01	-6.7872E-04	2.0457E-03	9.3438E-01
1.6043E+00	1.9662E+00	1.0268E+00	1.3340E+00	3.5732E-01	6.7506E-03	2.2608E-01	-4.6951E-05	7.5096E-04	7.9839E-02
1.8348E-01	4.8585E-01	4.9008E-01	3.5733E-01	1.3281E-01	1.6825E-03	6.5675E-02	-3.2514E-05	5.8292E-04	3.1121E-02
8.4737E-03	1.0195E-02	1.2523E-03	6.7509E-03	1.6826E-03	5.8402E-03	-2.0219E-02	-2.9016E-06	7.2598E-06	1.7277E-02
2.4852E-01	3.2997E-01	2.2121E-01	2.2608E-01	6.5674E-02	-2.0219E-02	2.0203E-01	1.1608E-05	-8.3372E-05	-4.6651E-02
-1.7678E-05	-5.4360E-05	-6.7872E-04	-4.6871E-05	-3.2504E-05	-2.9018E-06	1.1625E-05	2.8883E-05	-4.9912E-04	-1.0301E-02
1.3729E-04	8.1122E-04	2.0458E-03	7.4940E-04	5.8273E-04	7.2648E-06	-8.3691E-05	-4.9912E-04	1.0942E-02	1.1665E-01

7.7723E-02 1.1187E-01 9.3438E-01 7.9828E-02 3.1120E-02 1.7277E-02 -4.6653E-02 -1.0301E-02 1.1665E-01 7.3767E+00

KE, THE TRANSIENT ESTIMATE GAIN MATRIX

2.9802E-02	1.6172E-02	1.0450E-01	7.4557E-03
4.0875E-02	2.3462E-02	1.3346E-01	2.3301E-02
2.5286E-02	-8.5250E-02	6.1565E-02	3.1564E-02
2.8194E-02	1.6764E-02	9.0274E-02	1.7610E-02
8.1705E-03	6.2880E-03	2.4831E-02	6.5235E-03
1.4059E-04	3.5443E-03	2.4146E-02	5.0733E-05
4.8635E-03	-9.1091E-03	-5.0588E-02	3.4257E-03
-1.3232E-06	1.3246E-04	-1.1603E-05	-6.9662E-06
2.2207E-05	4.8406E-02	1.5401E-05	2.3016E-05
1.8495E-03	-7.7111E-01	7.4724E-02	9.7493E-03

TIME = 0.72000E+01

RICCATI SOLUTION MATRIX

3.4092E+01	1.5464E+00	-2.7696E+00	1.6123E+00	1.8647E-01	8.5150E-03	2.4990E-01	-1.7766E-05	1.3813E-04	7.8120E-02
1.5463E+00	3.7563E+00	1.0597E+00	1.9641E+00	4.8508E-01	1.0184E-02	3.2962E-01	-5.4426E-05	8.1296E-04	1.1177E-01
-2.7696E+00	1.0597E+00	3.0881E+00	1.0269E+00	4.9014E-01	1.2529E-03	2.2124E-01	-6.7873E-04	2.0457E-03	9.3439E-01
1.6123E+00	1.9641E+00	1.0269E+00	1.3341E+00	3.5736E-01	6.7512E-03	2.2610E-01	-4.6953E-05	7.5098E-04	7.9844E-02
1.8647E-01	4.8508E-01	4.9014E-01	3.5737E-01	1.3282E-01	1.6827E-03	6.5682E-02	-3.2515E-05	5.8292E-04	3.1123E-02
8.5150E-03	1.0184E-02	1.2529E-03	6.7515E-03	1.6828E-03	5.8402E-03	-2.0219E-02	-2.9016E-06	7.2598E-06	1.7277E-02
2.4990E-01	3.2962E-01	2.2123E-01	2.2610E-01	6.5681E-02	-2.0219E-02	2.0204E-01	1.1608E-05	-8.3369E-05	-4.6650E-02
-1.7766E-05	-5.4426E-05	-6.7872E-04	-4.6871E-05	-3.2505E-05	-2.9018E-06	1.1624E-05	2.8883E-05	-4.9912E-04	-1.0301E-02
1.3813E-04	7.8120E-02	1.1177E-01	9.3438E-01	7.9828E-02	3.1122E-02	1.7277E-02	-4.6652E-02	-1.0301E-02	1.1665E-01
7.8120E-02	1.1177E-01	9.3438E-01	7.9833E-02	3.1122E-02	1.7277E-02	-4.6652E-02	-1.0301E-02	1.1665E-01	7.3767E+00

KE, THE TRANSIENT ESTIMATE GAIN MATRIX

2.9986E-02	1.6255E-02	1.0505E-01	7.6256E-03
4.0829E-02	2.3440E-02	1.3333E-01	2.3258E-02
2.5289E-02	-8.5250E-02	6.1573E-02	3.1567E-02
2.8197E-02	1.6765E-02	9.0281E-02	1.7613E-02
8.1715E-03	6.2883E-03	2.4834E-02	6.5244E-03
1.4060E-04	3.5443E-03	2.4146E-02	5.0745E-05
4.8640E-03	-9.1090E-03	-5.0587E-02	3.4261E-03
-1.3232E-06	1.3245E-04	-1.1603E-05	-6.9662E-06
2.2207E-05	4.8406E-02	1.5401E-05	2.3016E-05
1.8496E-03	-7.7111E-01	7.4724E-02	9.7494E-03

TIME = 0.74000E+01

RICCATI SOLUTION MATRIX

3.4461E+01	1.4322E+00	-2.7523E+00	1.6205E+00	1.8935E-01	8.5568E-03	2.5129E-01	-1.7842E-05	1.3841E-04	7.8525E-02
1.4322E+00	3.7892E+00	1.0556E+00	1.9620E+00	4.8430E-01	1.0173E-02	3.2925E-01	-5.4405E-05	8.1287E-04	1.1166E-01
-2.7523E+00	1.0556E+00	3.0882E+00	1.0271E+00	4.9022E-01	1.2539E-03	2.2127E-01	-6.7872E-04	2.0457E-03	9.3440E-01
1.6205E+00	1.9620E+00	1.0271E+00	1.3342E+00	3.5741E-01	6.7519E-03	2.2612E-01	-4.6953E-05	7.5097E-04	7.9850E-02
1.8935E-01	4.8430E-01	4.9022E-01	3.5742E-01	1.3284E-01	1.6830E-03	6.5690E-02	-3.2515E-05	5.8292E-04	3.1126E-02
8.5568E-03	1.0173E-02	1.2539E-03	6.7521E-03	1.6830E-03	5.8402E-03	-2.0219E-02	-2.9017E-06	7.2598E-06	1.7277E-02
2.5129E-01	3.2925E-01	2.2127E-01	2.2612E-01	6.5690E-02	-2.0219E-02	2.0204E-01	1.1608E-05	-8.3369E-05	-4.6649E-02
-1.7842E-05	-5.4422E-05	-6.7872E-04	-4.6873E-05	-3.2505E-05	-2.9018E-06	1.1624E-05	2.8883E-05	-4.9912E-04	-1.0301E-02
1.3841E-04	7.8525E-02	1.1166E-01	9.3439E-01	7.9844E-02	3.1124E-02	1.7277E-02	-4.6651E-02	-1.0301E-02	1.1665E-01
7.8525E-02	1.1166E-01	9.3439E-01	7.9840E-02	3.1124E-02	1.7277E-02	-4.6651E-02	-1.0301E-02	1.1665E-01	7.3767E+00

KF, THE TRANSIENT ESTIMATE GAIN MATRIX

3.0170E-02	1.6337E-02	1.0561E-01	7.7887E-03
4.0779E-02	2.3419E-02	1.3318E-01	2.3213E-02
2.5294E-02	-8.5247E-02	6.1587E-02	3.1572E-02
2.8200E-02	1.6766E-02	9.0290E-02	1.7615E-02
8.1726E-03	6.2889E-03	2.4838E-02	6.5255E-03
1.4061E-04	3.5443E-03	2.4146E-02	5.0760E-05
4.8645E-03	-9.1087E-03	-5.0586E-02	3.4266E-03
-1.3232E-06	1.3245E-04	-1.1603E-05	-6.9663E-06
2.2207E-05	4.8406E-02	1.5402E-05	2.3016E-05
1.8498E-03	-7.7111E-01	7.4725E-02	9.7496E-03

TIME = 0.76000E+01

RICCATI SOLUTION MATRIX

3.4783E+01	1.3268E+00	-2.7342E+00	1.6285E+00	1.9210E-01	8.5981E-03	2.5265E-01	-1.7915E-05	1.3877E-04	7.8922E-02
1.3268E+00	3.8213E+00	1.0510E+00	1.9597E+00	4.8350E-01	1.0161E-02	3.2886E-01	-5.4386E-05	8.1282E-04	1.1155E-01
-2.7342E+00	1.0510E+00	3.0886E+00	1.0274E+00	4.9032E-01	1.2553E-03	2.2131E-01	-6.7873E-04	2.0457E-03	9.3441E-01
1.6285E+00	1.9597E+00	1.0274E+00	1.3344E+00	3.5747E-01	6.7526E-03	2.2615E-01	-4.6956E-05	7.5100E-04	7.9858E-02
1.9210E-01	4.8350E-01	4.9032E-01	3.5747E-01	1.3286E-01	1.6833E-03	6.5699E-02	-3.2516E-05	5.8293E-04	3.1128E-02
8.5981E-03	1.0161E-02	1.2553E-03	6.7526E-03	1.6833E-03	5.8402E-03	-2.0219E-02	-2.9017E-06	7.2600E-06	1.7277E-02
2.5265E-01	3.2886E-01	2.2131E-01	2.2615E-01	6.5699E-02	-2.0219E-02	2.0204E-01	1.1608E-05	-8.3365E-05	-4.6647E-02
-1.7915E-05	-5.4386E-05	-6.7873E-04	-4.6874E-05	-3.2506E-05	-2.9018E-06	1.1624E-05	2.8883E-05	-4.9912E-04	-1.0301E-02
1.3877E-04	8.1098E-04	2.0459E-03	7.4942E-04	5.8274E-04	7.2648E-06	-8.3689E-05	-4.9912E-04	1.0942E-02	1.1665E-01
7.8922E-02	1.1155E-01	9.3441E-01	7.9847E-02	3.1127E-02	1.7278E-02	-4.6650E-02	-1.0301E-02	1.1665E-01	7.3767E+00

KE, THE TRANSIENT ESTIMATE GAIN MATRIX

3.0350E-02	1.6420E-02	1.0615E-01	7.9436E-03
4.0728E-02	2.3396E-02	1.3302E-01	2.3168E-02
2.5300E-02	-8.5244E-02	6.1605E-02	3.1578E-02
2.8203E-02	1.6768E-02	9.0300E-02	1.7618E-02
8.1738E-03	6.2895E-03	2.4841E-02	6.5265E-03
1.4063E-04	3.5443E-03	2.4146E-02	5.0775E-05
4.8650E-03	-9.1084E-03	-5.0584E-02	3.4271E-03
-1.3233E-06	1.3245E-04	-1.1603E-05	-6.9663E-06
2.2207E-05	4.8406E-02	1.5402E-05	2.3016E-05
1.8499E-03	-7.7111E-01	7.4725E-02	9.7497E-03

TIME = 0.78000E+01

RICCATI SOLUTION MATRIX

3.5063E+01	1.2301E+00	-2.7158E+00	1.6364E+00	1.9469E-01	8.6383E-03	2.5397E-01	-1.7988E-05	1.3910E-04	7.9307E-02
1.2301E+00	3.8524E+00	1.0458E+00	1.9573E+00	4.8271E-01	1.0149E-02	3.2847E-01	-5.4365E-05	8.1271E-04	1.1143E-01
-2.7158E+00	1.0459E+00	3.0891E+00	1.0277E+00	4.9043E-01	1.2569E-03	2.2137E-01	-6.7873E-04	2.0457E-03	9.3443E-01
1.6364E+00	1.9573E+00	1.0277E+00	1.3346E+00	3.5752E-01	6.7535E-03	2.2618E-01	-4.6958E-05	7.5099E-04	7.9867E-02
1.9469E-01	4.8271E-01	4.9043E-01	3.5753E-01	1.3288E-01	1.6836E-03	6.5709E-02	-3.2516E-05	5.8293E-04	3.1131E-02
8.6383E-03	1.0149E-02	1.2569E-03	6.7538E-03	1.6836E-03	5.8402E-03	-2.0219E-02	-2.9017E-06	7.2599E-06	1.7278E-02
2.5397E-01	3.2847E-01	2.2137E-01	2.2617E-01	6.5708E-02	-2.0219E-02	2.0205E-01	1.1607E-05	-8.3367E-05	-4.6646E-02
-1.7970E-05	-5.4280E-05	-6.7873E-04	-4.6875E-05	-3.2506E-05	-2.9018E-06	1.1624E-05	2.8883E-05	-4.9912E-04	-1.0301E-02
1.3851E-04	8.1089E-04	2.0459E-03	7.4942E-04	5.8274E-04	7.2648E-06	-8.3688E-05	-4.9912E-04	1.0942E-02	1.1665E-01
7.9315E-02	1.1143E-01	9.3442E-01	7.9855E-02	3.1130E-02	1.7278E-02	-4.6648E-02	-1.0301E-02	1.1665E-01	7.3767E+00

KE, THE TRANSIENT ESTIMATE GAIN MATRIX

3.0524E-02	1.6499E-02	1.0668E-01	8.0892E-03
4.0675E-02	2.3371E-02	1.3286E-01	2.3123E-02
2.5307E-02	-8.5242E-02	6.1627E-02	3.1584E-02
2.8207E-02	1.6769E-02	9.0312E-02	1.7622E-02
8.1751E-03	6.2899E-03	2.4845E-02	6.5277E-03
1.4065E-04	3.5443E-03	2.4146E-02	5.0792E-05
4.8657E-03	-9.1082E-03	-5.0582E-02	3.4276E-03
-1.3233E-06	1.3246E-04	-1.1603E-05	-6.9663E-06
2.2207E-05	4.8406E-02	1.5402E-05	2.3016E-05
1.8501E-03	-7.7111E-01	7.4726E-02	9.7499E-03

TIME = 0.80000E+01

RICCATI SOLUTION MATRIX									
3.5303E+01	1.1419E+00	-2.6973E+00	1.6439E+00	1.9710E-01	8.6768E-03	2.5522E-01	-1.8053E-05	1.3933E-04	7.9677E-02
1.1419E+00	3.8824E+00	1.0403E+00	1.9549E+00	4.8192E-01	1.0137E-02	3.2806E-01	-5.4341E-05	8.1258E-04	1.1132E-01
-2.6973E+00	1.0404E+00	3.0899E+00	1.0281E+00	4.9057E-01	1.2589E-03	2.2144E-01	-6.7873E-04	2.0457E-03	9.3445E-01
1.6439E+00	1.9549E+00	1.0281E+00	1.3347E+00	3.5758E-01	6.7544E-03	2.2621E-01	-4.6958E-05	7.5098E-04	7.9875E-02
1.9710E-01	4.8192E-01	4.9056E-01	3.5759E-01	1.3290E-01	1.6839E-03	6.5719E-02	-3.2516E-05	5.8293E-04	3.1134E-02
8.6768E-03	1.0137E-02	1.2589E-03	6.7547E-03	1.6839E-03	5.8402E-03	-2.0219E-02	-2.9017E-06	7.2600E-06	1.7278E-02
2.5522E-01	3.2806E-01	2.2143E-01	2.2620E-01	6.5719E-02	-2.0219E-02	2.0205E-01	1.1607E-05	-8.3369E-05	-4.6645E-02
-1.8053E-05	-5.4258E-05	-6.7873E-04	-4.6877E-05	-3.2507E-05	-2.9018E-06	1.1624E-05	2.8883E-05	-4.9912E-04	-1.0301E-02
1.3933E-04	8.1080E-04	2.0459E-03	7.4943E-04	5.8274E-04	7.2650E-06	-8.3687E-05	-4.9912E-04	1.0942E-02	1.1665E-01
7.9677E-02	1.1131E-01	9.3444E-01	7.9864E-02	3.1133E-02	1.7278E-02	-4.6647E-02	-1.0301E-02	1.1665E-01	7.3767E+00

KE, THE TRANSIENT ESTIMATE GAIN MATRIX

3.0689E-02	1.6575E-02	1.0719E-01	8.2248E-03
4.0622E-02	2.3347E-02	1.3270E-01	2.3078E-02
2.5316E-02	-8.5237E-02	6.1653E-02	3.1592E-02
2.8211E-02	1.6771E-02	9.0324E-02	1.7625E-02
8.1764E-03	6.2907E-03	2.4849E-02	6.5288E-03
1.4067E-04	3.5443E-03	2.4146E-02	5.0809E-05
4.8664E-03	-9.1079E-03	-5.0580E-02	3.4282E-03
-1.3233E-06	1.3245E-04	-1.1603E-05	-6.9663E-06
2.2207E-05	4.8406E-02	1.5403E-05	2.3016E-05
1.8503E-03	-7.7111E-01	7.4726E-02	9.7501E-03

TIME = 0.82000E+01

RICCATI SOLUTION MATRIX									
3.5507E+01	1.0621E+00	-2.6792E+00	1.6509E+00	1.9934E-01	8.7132E-03	2.5641E-01	-1.8118E-05	1.3964E-04	8.0028E-02
1.0621E+00	3.9112E+00	1.0346E+00	1.9525E+00	4.8115E-01	1.0124E-02	3.2766E-01	-5.4320E-05	8.1252E-04	1.1120E-01
-2.6792E+00	1.0346E+00	3.0908E+00	1.0285E+00	4.9071E-01	1.2611E-03	2.2151E-01	-6.7874E-04	2.0458E-03	9.3447E-01
1.6509E+00	1.9525E+00	1.0285E+00	1.3349E+00	3.5765E-01	6.7554E-03	2.2624E-01	-4.6960E-05	7.5101E-04	7.9884E-02
1.9934E-01	4.8115E-01	4.9071E-01	3.5765E-01	1.3292E-01	1.6842E-03	6.5730E-02	-3.2517E-05	5.8294E-04	3.1137E-02
8.7132E-03	1.0125E-02	1.2611E-03	6.7557E-03	1.6842E-03	5.8402E-03	-2.0218E-02	-2.9017E-06	7.2599E-06	1.7278E-02
2.5641E-01	3.2766E-01	2.2151E-01	2.2624E-01	6.5729E-02	-2.0219E-02	2.0206E-01	1.1607E-05	-8.3362E-05	-4.6643E-02
-1.8103E-05	-5.4236E-05	-6.7874E-04	-4.6879E-05	-3.2507E-05	-2.9018E-06	1.1623E-05	2.8883E-05	-4.9912E-04	-1.0301E-02
1.3910E-04	8.1070E-04	2.0459E-03	7.4944E-04	5.8274E-04	7.2650E-06	-8.3685E-05	-4.9912E-04	1.0942E-02	1.1665E-01
3.0034E-02	1.1119E-01	9.3446E-01	7.9874E-02	3.1136E-02	1.7278E-02	-4.6645E-02	-1.0301E-02	1.1665E-01	7.3767E+00

KE, THE TRANSIENT ESTIMATE GAIN MATRIX

3.0844E-02	1.6648E-02	1.0767E-01	8.3500E-03
4.0569E-02	2.3323E-02	1.3254E-01	2.3035E-02

2.5326E-02	-8.5233E-02	6.1683E-02	3.1600E-02
2.8215E-02	1.6773E-02	9.0337E-02	1.7629E-02
6.1778E-03	6.2913E-03	2.4853E-02	6.5299E-03
1.4069E-04	3.5443E-03	2.4146E-02	5.0827E-05
4.8671E-03	-9.1075E-03	-5.0578E-02	3.4288E-03
-1.3234E-06	1.3246E-04	-1.1603E-05	-6.9664E-06
2.2208E-05	4.8406E-02	1.5403E-05	2.3016E-05
1.8505E-03	-7.7111E-01	7.4727E-02	5.7502E-03

TIME = 0.84000E+01

RICCATI SOLUTION MATRIX

3.5678E+01	9.9051E-01	-2.6617E+00	1.6576E+00	2.0139E-01	8.7472E-03	2.5751E-01	-1.8179E-05	1.3990E-04	8.0354E-02
9.9050E-01	3.9386E+00	1.0286E+00	1.9501E+00	4.8039E-01	1.0112E-02	3.2726E-01	-5.4298E-05	8.1241E-04	1.1108E-01
-2.6617E+00	1.0286E+00	3.0919E+00	1.0290E+00	4.9087E-01	1.2636E-03	2.2159E-01	-6.7874E-04	2.0458E-03	9.3449E-01
1.6576E+00	1.9501E+00	1.0290E+00	1.3351E+00	3.5771E-01	6.7564E-03	2.2627E-01	-4.6562E-05	7.5101E-04	7.9895E-02
2.0139E-01	4.8040E-01	4.9086E-01	3.5771E-01	1.3294E-01	1.6845E-03	6.5740E-02	-3.2518E-05	5.8294E-04	3.1141E-02
8.7472E-03	1.0112E-02	1.2636E-03	6.7567E-03	1.6845E-03	5.8402E-03	-2.0218E-02	-2.9017E-06	7.2601E-06	1.7278E-02
2.5751E-01	3.2726E-01	2.2159E-01	2.2627E-01	6.5740E-02	-2.0218E-02	2.0207E-01	1.1607E-05	-8.3363E-05	-4.6641E-02
-1.8164E-05	-5.4214E-05	-6.7874E-04	-4.6881E-05	-3.2508E-05	-2.9019E-06	1.1623E-05	2.8883E-05	-4.9912E-04	-1.0301E-02
1.3990E-04	8.1060E-04	2.0459E-03	7.4945E-04	5.8275E-04	7.2650E-06	-8.3684E-05	-4.9912E-04	1.0942E-02	1.1665E-01
8.0354E-02	1.1108E-01	9.3449E-01	7.9883E-02	3.1139E-02	1.7278E-02	-4.6644E-02	-1.0301E-02	1.1665E-01	7.3767E+00

KE, THE TRANSIENT ESTIMATE GAIN MATRIX

3.0989E-02	1.6715E-02	1.0811E-01	8.4646E-03
4.0517E-02	2.3299E-02	1.3238E-01	2.2993E-02
2.5336E-02	-8.5227E-02	6.1715E-02	3.1609E-02
2.8220E-02	1.6776E-02	9.0350E-02	1.7632E-02
8.1792E-03	6.2920E-03	2.4858E-02	6.5311E-03
1.4072E-04	3.5443E-03	2.4146E-02	5.0846E-05
4.8678E-03	-9.1072E-03	-5.0575E-02	3.4294E-03
-1.3234E-06	1.3245E-04	-1.1604E-05	-6.9664E-06
2.2208E-05	4.8406E-02	1.5404E-05	2.3016E-05
1.8507E-03	-7.7111E-01	7.4728E-02	9.7504E-03

TIME = 0.86000E+01

RICCATI SOLUTION MATRIX

3.5820E+01	9.2672E-01	-2.6450E+00	1.6637E+00	2.0325E-01	8.7786E-03	2.5853E-01	-1.8237E-05	1.4017E-04	8.0655E-02
9.2671E-01	3.9645E+00	1.0224E+00	1.9478E+00	4.7967E-01	1.0100E-02	3.2687E-01	-5.4277E-05	8.1232E-04	1.1096E-01
-2.6450E+00	1.0224E+00	3.0931E+00	1.0295E+00	4.9103E-01	1.2642E-03	2.2168E-01	-6.7875E-04	2.0458E-03	9.3452E-01
1.6637E+00	1.9478E+00	1.0295E+00	1.3353E+00	3.5777E-01	6.7574E-03	2.2631E-01	-4.6964E-05	7.5101E-04	7.9904E-02
2.0325E-01	4.7967E-01	4.9103E-01	3.5778E-01	1.3296E-01	1.6848E-03	6.5751E-02	-3.2518E-05	5.8294E-04	3.1144E-02
8.7786E-03	1.0100E-02	1.2642E-03	6.7577E-03	1.6849E-03	5.8402E-03	-2.0218E-02	-2.9017E-06	7.2603E-06	1.7278E-02
2.5853E-01	3.2687E-01	2.2167E-01	2.2630E-01	6.5750E-02	-2.0218E-02	2.0207E-01	1.1606E-05	-8.3364E-05	-4.6640E-02
-1.8220E-05	-5.4193E-05	-6.7875E-04	-4.6883E-05	-3.2508E-05	-2.9019E-06	1.1623E-05	2.8883E-05	-4.9912E-04	-1.0301E-02
1.3993E-04	8.1051E-04	2.0459E-03	7.4946E-04	5.8275E-04	7.2650E-06	-8.3683E-05	-4.9912E-04	1.0942E-02	1.1665E-01
8.0660E-02	1.1096E-01	9.3451E-01	7.9893E-02	3.1142E-02	1.7278E-02	-4.6642E-02	-1.0301E-02	1.1665E-01	7.3767E+00

KE, THE TRANSIENT ESTIMATE GAIN MATRIX

3.1121E-02	1.6776E-02	1.0852E-01	8.5686E-03
4.0466E-02	2.3274E-02	1.3222E-01	2.2952E-02
2.5348E-02	-8.5223E-02	6.1750E-02	3.1618E-02
2.8224E-02	1.6777E-02	9.0364E-02	1.7636E-02

8.1806E-03	6.2925E-03	2.4862E-02	6.5322E-03
1.4074E-04	3.5443E-03	2.4146E-02	5.0864E-05
4.8685E-03	-9.1069E-03	-5.0573E-02	3.4300E-03
-1.3234E-06	1.3245E-04	-1.1604E-05	-6.9664E-06
2.2208E-05	4.8406E-02	1.5404E-05	2.3017E-05
1.8510E-03	-7.7111E-01	7.4728E-02	5.7506E-03

TIME = 0.88000E+01

RICCATI SOLUTION MATRIX

3.5936E+01	8.7040E-01	-2.6292E+00	1.6692E+00	2.0493E-01	8.8073E-03	2.5945E-01	-1.8287E-05	1.4042E-04	8.0929E-02
8.7039E-01	3.9890E+00	1.0162E+00	1.9455E+00	4.7897E-01	1.0088E-02	3.2649E-01	-5.4255E-05	8.1223E-04	1.1085E-01
-2.6292E+00	1.0163E+00	3.0945E+00	1.0301E+00	4.9120E-01	1.2690E-03	2.2177E-01	-6.7875E-04	2.0458E-03	9.3454E-01
1.6692E+00	1.9455E+00	1.0300E+00	1.3355E+00	3.5784E-01	6.7585E-03	2.2634E-01	-4.6566E-05	7.5103E-04	7.9915E-02
2.0493E-01	4.7897E-01	4.9120E-01	3.5784E-01	1.3298E-01	1.6852E-03	6.5762E-02	-3.2519E-05	5.8294E-04	3.1147E-02
8.8073E-03	1.0089E-02	1.2690E-03	6.7588E-03	1.6852E-03	5.8402E-03	-2.0218E-02	-2.9017E-06	7.2603E-06	1.7278E-02
2.5945E-01	3.2649E-01	2.2176E-01	2.2634E-01	6.5761E-02	-2.0218E-02	2.0208E-01	1.1606E-05	-8.3360E-05	-4.6638E-02
-1.8272E-05	-5.4172E-05	-6.7875E-04	-4.6884E-05	-3.2509E-05	-2.9019E-06	1.1622E-05	2.8883E-05	-4.9912E-04	-1.0301E-02
1.3987E-04	8.1041E-04	2.0460E-03	7.4946E-04	5.8275E-04	7.2651E-06	-8.3682E-05	-4.9912E-04	1.0942E-02	1.1665E-01
8.0934E-02	1.1085E-01	9.3454E-01	7.9904E-02	3.1145E-02	1.7278E-02	-4.6640E-02	-1.0301E-02	1.1665E-01	7.3767E+00

KE, THE TRANSIENT ESTIMATE GAIN MATRIX

3.1242E-02	1.6834E-02	1.0890E-01	8.6621E-03
4.0416E-02	2.3252E-02	1.3206E-01	2.2913E-02
2.5359E-02	-8.5217E-02	6.1787E-02	3.1628E-02
2.8229E-02	1.6780E-02	9.0378E-02	1.7639E-02
8.1820E-03	6.2933E-03	2.4866E-02	6.5333E-03
1.4076E-04	3.5444E-03	2.4147E-02	5.0883E-05
4.8693E-03	-9.1064E-03	-5.0571E-02	3.4306E-03
-1.3235E-06	1.3245E-04	-1.1604E-05	-6.9665E-06
2.2208E-05	4.8406E-02	1.5405E-05	2.3017E-05
1.8512E-03	-7.7111E-01	7.4729E-02	9.7508E-03

TIME = 0.90000E+01

RICCATI SOLUTION MATRIX

3.6030E+01	8.2114E-01	-2.6145E+00	1.6743E+00	2.0642E-01	8.8332E-03	2.6029E-01	-1.8332E-05	1.4059E-04	8.1177E-02
8.2113E-01	4.0119E+00	1.0101E+00	1.9433E+00	4.7830E-01	1.0077E-02	3.2612E-01	-5.4235E-05	8.1214E-04	1.1074E-01
-2.6145E+00	1.0101E+00	3.0960E+00	1.0306E+00	4.9137E-01	1.2719E-03	2.2186E-01	-6.7876E-04	2.0458E-03	9.3457E-01
1.6743E+00	1.9433E+00	1.0306E+00	1.3357E+00	3.5790E-01	6.7596E-03	2.2638E-01	-4.6568E-05	7.5104E-04	7.9925E-02
2.0642E-01	4.7830E-01	4.9137E-01	3.5790E-01	1.3300E-01	1.6855E-03	6.5772E-02	-3.2520E-05	5.8295E-04	3.1150E-02
8.8333E-03	1.0077E-02	1.2719E-03	6.7598E-03	1.6855E-03	5.8402E-03	-2.0218E-02	-2.9017E-06	7.2602E-06	1.7278E-02
2.6029E-01	3.2612E-01	2.2186E-01	2.2637E-01	6.5772E-02	-2.0218E-02	2.0208E-01	1.1606E-05	-8.3359E-05	-4.6636E-02
-1.8318E-05	-5.4151E-05	-6.7876E-04	-4.6886E-05	-3.2509E-05	-2.9019E-06	1.1622E-05	2.8883E-05	-4.9912E-04	-1.0301E-02
1.4008E-04	8.1032E-04	2.0460E-03	7.4947E-04	5.8276E-04	7.2652E-06	-8.3680E-05	-4.9912E-04	1.0942E-02	1.1665E-01
8.1182E-02	1.1074E-01	9.3457E-01	7.9914E-02	3.1148E-02	1.7278E-02	-4.6639E-02	-1.0301E-02	1.1665E-01	7.3767E+00

KE, THE TRANSIENT ESTIMATE GAIN MATRIX

3.1351E-02	1.6884E-02	1.0924E-01	8.7454E-03
4.0368E-02	2.3230E-02	1.3192E-01	2.2875E-02
2.5372E-02	-8.5212E-02	6.1824E-02	3.1637E-02
2.8233E-02	1.6782E-02	9.0392E-02	1.7643E-02
8.1834E-03	6.2938E-03	2.4871E-02	6.5344E-03
1.4078E-04	3.5444E-03	2.4147E-02	5.0901E-05

4.8700E-03 -9.1061E-03 -5.0568E-02 3.4312E-03
 -1.3235E-06 1.3245E-04 -1.1604E-05 -6.9665E-06
 2.2208E-05 4.8406E-02 1.5406E-05 2.3017E-05
 1.8514E-03 -7.7111E-01 7.4730E-02 9.7509E-03

TIME = 0.92000E+01

RICCATI SOLUTION MATRIX

3.6103E+01	7.7850E-01	-2.6009E+00	1.6788E+00	2.0775E-01	8.8564E-03	2.6104E-01	-1.8374E-05	1.4077E-04	8.1399E-02
7.7849E-01	4.0333E+00	1.0039E+00	1.9412E+00	4.7766E-01	1.0066E-02	3.2577E-01	-5.4216E-05	8.1205E-04	1.1064E-01
-2.6309E+00	1.0040E+00	3.0976E+00	1.0312E+00	4.9155E-01	1.2749E-03	2.2196E-01	-6.7876E-04	2.0458E-03	9.3460E-01
1.6788E+00	1.9412E+00	1.0312E+00	1.3360E+00	3.5796E-01	6.7606E-03	2.2641E-01	-4.6970E-05	7.5104E-04	7.9935E-02
2.0775E-01	4.7766E-01	4.9155E-01	3.5797E-01	1.3302E-01	1.6858E-03	6.5783E-02	-3.2520E-05	5.8295E-04	3.1153E-02
8.8564E-03	1.0066E-02	1.2749E-03	6.7609E-03	1.6858E-03	5.8402E-03	-2.0218E-02	-2.9017E-06	7.2606E-06	1.7278E-02
2.6104E-01	3.2577E-01	2.2195E-01	2.2641E-01	6.5782E-02	-2.0218E-02	2.0209E-01	1.1605E-05	-8.3359E-05	-4.6635E-02
-1.8360E-05	-5.4132E-05	-6.7876E-04	-4.6888E-05	-3.2510E-05	-2.9019E-06	1.1622E-05	2.8883E-05	-4.9912E-04	-1.0301E-02
1.4028E-04	8.1023E-04	2.0460E-03	7.4948E-04	5.8276E-04	7.2652E-06	-8.3679E-05	-4.9912E-04	1.0942E-02	1.1665E-01
8.1403E-02	1.1063E-01	9.3459E-01	7.9924E-02	3.1151E-02	1.7278E-02	-4.6637E-02	-1.0301E-02	1.1665E-01	7.3767E+00

KE, THE TRANSIENT ESTIMATE GAIN MATRIX

3.1448E-02	1.6930E-02	1.0954E-01	8.8189E-03
4.0322E-02	2.3208E-02	1.3177E-01	2.2840E-02
2.5384E-02	-8.5206E-02	6.1863E-02	3.1647E-02
2.8238E-02	1.6784E-02	9.0406E-02	1.7646E-02
8.1847E-03	6.2945E-03	2.4875E-02	6.5354E-03
1.4081E-04	3.5444E-03	2.4147E-02	5.0919E-05
4.8708E-03	-9.1058E-03	-5.0566E-02	3.4318E-03
-1.3236E-06	1.3246E-04	-1.1604E-05	-6.9665E-06
2.2208E-05	4.8406E-02	1.5406E-05	2.3017E-05
1.8516E-03	-7.7111E-01	7.4730E-02	9.7511E-03

TIME = 0.94000E+01

RICCATI SOLUTION MATRIX

3.6159E+01	7.4204E-01	-2.5886E+00	1.6828E+00	2.0890E-01	8.8769E-03	2.6170E-01	-1.8412E-05	1.4097E-04	8.1593E-02
7.4203E-01	4.0531E+00	9.9795E-01	1.9391E+00	4.7706E-01	1.0056E-02	3.2543E-01	-5.4197E-05	8.1199E-04	1.1054E-01
-2.5886E+00	9.9796E-01	3.0993E+00	1.0318E+00	4.9172E-01	1.2779E-03	2.2205E-01	-6.7877E-04	2.0459E-03	9.3463E-01
1.6828E+00	1.9391E+00	1.0318E+00	1.3362E+00	3.5802E-01	6.7617E-03	2.2644E-01	-4.6972E-05	7.5107E-04	7.9945E-02
2.0890E-01	4.7706E-01	4.9172E-01	3.5803E-01	1.3304E-01	1.6861E-03	6.5793E-02	-3.2521E-05	5.8295E-04	3.1156E-02
8.8769E-03	1.0056E-02	1.2779E-03	6.7619E-03	1.6861E-03	5.8402E-03	-2.0217E-02	-2.9017E-06	7.2604E-06	1.7278E-02
2.6169E-01	3.2543E-01	2.2205E-01	2.2644E-01	6.5792E-02	-2.0217E-02	2.0209E-01	1.1605E-05	-8.3354E-05	-4.6633E-02
-1.8397E-05	-5.4113E-05	-6.7877E-04	-4.6890E-05	-3.2511E-05	-2.9019E-06	1.1621E-05	2.8883E-05	-4.9912E-04	-1.0301E-02
1.4045E-04	8.1014E-04	2.0460E-03	7.4949E-04	5.8276E-04	7.2652E-06	-8.3677E-05	-4.9912E-04	1.0942E-02	1.1665E-01
8.1599E-02	1.1054E-01	9.3462E-01	7.9934E-02	3.1154E-02	1.7278E-02	-4.6635E-02	-1.0301E-02	1.1665E-01	7.3767E+00

KE, THE TRANSIENT ESTIMATE GAIN MATRIX

3.1534E-02	1.6970E-02	1.0981E-01	8.8830E-03
4.0278E-02	2.3188E-02	1.3164E-01	2.2807E-02
2.5397E-02	-8.5199E-02	6.1903E-02	3.1657E-02
2.8242E-02	1.6786E-02	9.0419E-02	1.7650E-02
8.1860E-03	6.2952E-03	2.4879E-02	6.5364E-03
1.4083E-04	3.5444E-03	2.4147E-02	5.0936E-05
4.8715E-03	-9.1054E-03	-5.0564E-02	3.4323E-03
-1.3236E-06	1.3245E-04	-1.1604E-05	-6.9666E-06

2.2209E-05 4.8406E-02 1.5407E-05 2.3017E-05
 1.8518E-03 -7.7111E-01 7.4731E-02 9.7513E-03

TIME = 0.96000E+01

RICCATI SOLUTION MATRIX

3.6201E+01	7.1128E-01	-2.5776E+00	1.6862E+00	2.0990E-01	8.8947E-03	2.6227E-01	-1.8444E-05	1.4113E-04	8.1764E-02
7.1127E-01	4.0713E+00	9.9211E-01	1.9372E+00	4.7650E-01	1.0046E-02	3.2512E-01	-5.4180E-05	8.1189E-04	1.1045E-01
-2.5776E+00	9.9212E-01	3.1010E+00	1.0324E+00	4.9190E-01	1.2809E-03	2.2215E-01	-6.7878E-04	2.0459E-03	9.3466E-01
1.6862E+00	1.9372E+00	1.0324E+00	1.3364E+00	3.5808E-01	6.7627E-03	2.2648E-01	-4.6974E-05	7.5107E-04	7.9955E-02
2.0990E-01	4.7650E-01	4.9190E-01	3.5808E-01	1.3305E-01	1.6864E-03	6.5802E-02	-3.2522E-05	5.8295E-04	3.1159E-02
8.8948E-03	1.0046E-02	1.2809E-03	6.7630E-03	1.6864E-03	5.8402E-03	-2.0217E-02	-2.9017E-06	7.2603E-06	1.7278E-02
2.6227E-01	3.2511E-01	2.2215E-01	2.2647E-01	6.5802E-02	-2.0217E-02	2.0210E-01	1.1605E-05	-8.3354E-05	-4.6631E-02
-1.8429E-05	-5.4095E-05	-6.7877E-04	-4.6892E-05	-3.2511E-05	-2.9019E-06	1.1621E-05	2.8883E-05	-4.9912E-04	-1.0301E-02
1.4060E-04	8.1006E-04	2.0461E-03	7.4950E-04	5.8276E-04	7.2652E-06	-8.3676E-05	-4.9912E-04	1.0942E-02	1.1665E-01
8.1769E-02	1.1044E-01	9.3465E-01	7.9943E-02	3.1157E-02	1.7278E-02	-4.6634E-02	-1.0301E-02	1.1665E-01	7.3767E+00

KE, THE TRANSIENT ESTIMATE GAIN MATRIX

3.1608E-02	1.7005E-02	1.1004E-01	8.9383E-03
4.0237E-02	2.3168E-02	1.3151E-01	2.2775E-02
2.5410E-02	-8.5194E-02	6.1942E-02	3.1667E-02
2.8246E-02	1.6788E-02	9.0432E-02	1.7653E-02
8.1873E-03	6.2956E-03	2.4883E-02	6.5374E-03
1.4085E-04	3.5444E-03	2.4147E-02	5.0953E-05
4.8722E-03	-9.1052E-03	-5.0562E-02	3.4329E-03
-1.3237E-06	1.3245E-04	-1.1604E-05	-6.9666E-06
2.2209E-05	4.8406E-02	1.5407E-05	2.3017E-05
1.8520E-03	-7.7111E-01	7.4732E-02	9.7514E-03

TIME = 0.98000E+01

RICCATI SOLUTION MATRIX

3.6230E+01	6.8574E-01	-2.5679E+00	1.6892E+00	2.1075E-01	8.9101E-03	2.6276E-01	-1.8472E-05	1.4123E-04	8.1908E-02
6.8573E-01	4.0880E+00	9.8647E-01	1.9354E+00	4.7597E-01	1.0037E-02	3.2482E-01	-5.4164E-05	8.1183E-04	1.1036E-01
-2.5679E+00	9.8648E-01	3.1028E+00	1.0330E+00	4.9207E-01	1.2840E-03	2.2225E-01	-6.7878E-04	2.0460E-03	9.3469E-01
1.6892E+00	1.9354E+00	1.0330E+00	1.3365E+00	3.5814E-01	6.7637E-03	2.2651E-01	-4.6976E-05	7.5109E-04	7.9964E-02
2.1074E-01	4.7598E-01	4.9207E-01	3.5814E-01	1.3307E-01	1.6867E-03	6.5812E-02	-3.2522E-05	5.8296E-04	3.1161E-02
8.9101E-03	1.0037E-02	1.2839E-03	6.7639E-03	1.6867E-03	5.8402E-03	-2.0217E-02	-2.9018E-06	7.2603E-06	1.7278E-02
2.6276E-01	3.2481E-01	2.2224E-01	2.2650E-01	6.5811E-02	-2.0217E-02	2.0210E-01	1.1604E-05	-8.3349E-05	-4.6630E-02
-1.8456E-05	-5.4079E-05	-6.7878E-04	-4.6894E-05	-3.2512E-05	-2.9019E-06	1.1621E-05	2.8883E-05	-4.9912E-04	-1.0301E-02
1.4073E-04	8.0998E-04	2.0461E-03	7.4951E-04	5.8276E-04	7.2652E-06	-8.3675E-05	-4.9912E-04	1.0942E-02	1.1665E-01
8.1915E-02	1.1035E-01	9.3468E-01	7.9953E-02	3.1160E-02	1.7278E-02	-4.6632E-02	-1.0301E-02	1.1665E-01	7.3767E+00

KE, THE TRANSIENT ESTIMATE GAIN MATRIX

3.1672E-02	1.7034E-02	1.1024E-01	8.9852E-03
4.0198E-02	2.3150E-02	1.3139E-01	2.2746E-02
2.5422E-02	-8.5188E-02	6.1982E-02	3.1676E-02
2.8250E-02	1.6790E-02	9.0445E-02	1.7656E-02
8.1885E-03	6.2962E-03	2.4886E-02	6.5383E-03
1.4087E-04	3.5444E-03	2.4147E-02	5.0969E-05
4.8729E-03	-9.1048E-03	-5.0560E-02	3.4334E-03
-1.3237E-06	1.3245E-04	-1.1604E-05	-6.9666E-06
2.2209E-05	4.8406E-02	1.5407E-05	2.3017E-05
1.8522E-03	-7.7111E-01	7.4732E-02	9.7516E-03

TIME = 0.10000E+02

RICCATI SOLUTION MATRIX

3.6249E+01	6.6494E-01	-2.5594E+00	1.6917E+00	2.1145E-01	8.9231E-03	2.6318E-01	-1.8495E-05	1.4169E-04	8.2031E-02
6.6493E-01	4.1032E+00	9.8106E-01	1.9337E+00	4.7548E-01	1.0028E-02	3.2454E-01	-5.4144E-05	8.1161E-04	1.1027E-01
-2.5595E+00	9.8107E-01	3.1046E+00	1.0336E+00	4.9224E-01	1.2869E-03	2.2234E-01	-6.7878E-04	2.0458E-03	9.3472E-01
1.6917E+00	1.9337E+00	1.0335E+00	1.3367E+00	3.5819E-01	6.7646E-03	2.2654E-01	-4.6975E-05	7.5102E-04	7.9973E-02
2.1145E-01	4.7549E-01	4.9224E-01	3.5819E-01	1.3309E-01	1.6870E-03	6.5820E-02	-3.2522E-05	5.8293E-04	3.1164E-02
8.9231E-03	1.0028E-02	1.2869E-03	6.7649E-03	1.6870E-03	5.8402E-03	-2.0217E-02	-2.9018E-06	7.2602E-06	1.7278E-02
2.6317E-01	3.2453E-01	2.2234E-01	2.2654E-01	6.5820E-02	-2.0217E-02	2.0211E-01	1.1605E-05	-8.3364E-05	-4.6628E-02
-1.8480E-05	-5.4063E-05	-6.7878E-04	-4.6895E-05	-3.2512E-05	-2.9019E-06	1.1620E-05	2.8883E-05	-4.9912E-04	-1.0301E-02
1.4084E-04	8.0991E-04	2.0461E-03	7.4951E-04	5.8277E-04	7.2654E-06	-8.3673E-05	-4.9912E-04	1.0942E-02	1.1665E-01
8.2038E-02	1.1027E-01	9.3471E-01	7.9962E-02	3.1162E-02	1.7278E-02	-4.6631E-02	-1.0301E-02	1.1665E-01	7.3767E+00

KE, THE TRANSIENT ESTIMATE GAIN MATRIX

3.1726E-02	1.7070E-02	1.1041E-01	9.0243E-03
4.0161E-02	2.3131E-02	1.3127E-01	2.2719E-02
2.5435E-02	-8.5184E-02	6.2021E-02	3.1686E-02
2.8254E-02	1.6791E-02	9.0458E-02	1.7659E-02
8.1896E-03	6.2965E-03	2.4890E-02	6.5392E-03
1.4089E-04	3.5444E-03	2.4147E-02	5.0984E-05
4.8736E-03	-9.1046E-03	-5.0558E-02	3.4339E-03
-1.3237E-06	1.3245E-04	-1.1605E-05	-6.9667E-06
2.2209E-05	4.8406E-02	1.5409E-05	2.3018E-05
1.8524E-03	-7.7111E-01	7.4733E-02	9.7517E-03

TIME = 0.10200E+02

RICCATI SOLUTION MATRIX

3.6260E+01	6.4840E-01	-2.5523E+00	1.6938E+00	2.1203E-01	8.9338E-03	2.6352E-01	-1.8511E-05	1.4131E-04	8.2144E-02
6.4839E-01	4.1170E+00	9.7591E-01	1.9321E+00	4.7503E-01	1.0020E-02	3.2427E-01	-5.4131E-05	8.1158E-04	1.1020E-01
-2.5523E+00	9.7592E-01	3.1064E+00	1.0341E+00	4.9241E-01	1.2899E-03	2.2244E-01	-6.7879E-04	2.0460E-03	9.3474E-01
1.6938E+00	1.9321E+00	1.0341E+00	1.3369E+00	3.5824E-01	6.7655E-03	2.2657E-01	-4.6978E-05	7.5104E-04	7.9983E-02
2.1203E-01	4.7503E-01	4.9240E-01	3.5825E-01	1.3310E-01	1.6873E-03	6.5829E-02	-3.2523E-05	5.8295E-04	3.1167E-02
8.9338E-03	1.0020E-02	1.2898E-03	6.7658E-03	1.6873E-03	5.8402E-03	-2.0217E-02	-2.9018E-06	7.2603E-06	1.7278E-02
2.6352E-01	3.2427E-01	2.2244E-01	2.2656E-01	6.5828E-02	-2.0217E-02	2.0211E-01	1.1604E-05	-8.3358E-05	-4.6627E-02
-1.8499E-05	-5.4048E-05	-6.7879E-04	-4.6897E-05	-3.2513E-05	-2.9019E-06	1.1620E-05	2.8883E-05	-4.9912E-04	-1.0301E-02
1.4093E-04	8.0984E-04	2.0461E-03	7.4952E-04	5.8277E-04	7.2654E-06	-8.3672E-05	-4.9912E-04	1.0942E-02	1.1665E-01
8.2140E-02	1.1019E-01	9.3474E-01	7.9971E-02	3.1165E-02	1.7278E-02	-4.6629E-02	-1.0301E-02	1.1665E-01	7.3767E+00

KE, THE TRANSIENT ESTIMATE GAIN MATRIX

3.1770E-02	1.7082E-02	1.1055E-01	9.0563E-03
4.0128E-02	2.3115E-02	1.3117E-01	2.2694E-02
2.5447E-02	-8.5177E-02	6.2059E-02	3.1695E-02
2.8258E-02	1.6793E-02	9.0469E-02	1.7662E-02
8.1907E-03	6.2971E-03	2.4893E-02	6.5400E-03
1.4091E-04	3.5444E-03	2.4147E-02	5.0999E-05
4.8742E-03	-9.1043E-03	-5.0556E-02	3.4343E-03
-1.3238E-06	1.3246E-04	-1.1605E-05	-6.9667E-06
2.2209E-05	4.8406E-02	1.5409E-05	2.3018E-05
1.8526E-03	-7.7111E-01	7.4734E-02	9.7519E-03

TIME = 0.10400E+02

RICCATI SOLUTION MATRIX

3.6264E+01	6.3567E-01	-2.5463E+00	1.6955E+00	2.1250E-01	8.9425E-03	2.6380E-01	-1.8525E-05	1.4160E-04	8.2221E-02
6.3566E-01	4.1294E+00	9.7104E-01	1.9307E+00	4.7462E-01	1.0012E-02	3.2403E-01	-5.4118E-05	8.1158E-04	1.1012E-01
-2.5463E+00	9.7105E-01	3.1082E+00	1.0347E+00	4.9256E-01	1.2927E-03	2.2253E-01	-6.7879E-04	2.0460E-03	9.3477E-01
1.6955E+00	1.9307E+00	1.0347E+00	1.3371E+00	3.5829E-01	6.7664E-03	2.2660E-01	-4.6979E-05	7.5107E-04	7.9991E-02
2.1250E-01	4.7462E-01	4.9256E-01	3.5829E-01	1.3311E-01	1.6875E-03	6.5837E-02	-3.2523E-05	5.8295E-04	3.1169E-02
8.9425E-03	1.0012E-02	1.2927E-03	6.7667E-03	1.6875E-03	5.8402E-03	-2.0217E-02	-2.9018E-06	7.2607E-06	1.7278E-02
2.6380E-01	3.2403E-01	2.2253E-01	2.2659E-01	6.5836E-02	-2.0217E-02	2.0212E-01	1.1604E-05	-8.3356E-05	-4.6625E-02
-1.8515E-05	-5.4035E-05	-6.7879E-04	-4.6899E-05	-3.2513E-05	-2.9019E-06	1.1620E-05	2.8883E-05	-4.9912E-04	-1.0301E-02
1.4100E-04	8.0978E-04	2.0462E-03	7.4953E-04	5.8277E-04	7.2654E-06	-8.3671E-05	-4.9912E-04	1.0942E-02	1.1665E-01
8.2223E-02	1.1012E-01	9.3476E-01	7.9979E-02	3.1167E-02	1.7278E-02	-4.6628E-02	-1.0301E-02	1.1665E-01	7.3767E+00

KE, THE TRANSIENT ESTIMATE GAIN MATRIX

3.1806E-02	1.7105E-02	1.1066E-01	9.0818E-03
4.0096E-02	2.3102E-02	1.3107E-01	2.2671E-02
2.5459E-02	-8.5172E-02	6.2096E-02	3.1704E-02
2.8262E-02	1.6795E-02	9.0481E-02	1.7665E-02
8.1918E-03	6.2977E-03	2.4897E-02	6.5407E-03
1.4093E-04	3.5445E-03	2.4147E-02	5.1012E-05
4.8748E-03	-9.1040E-03	-5.0554E-02	3.4348E-03
-1.3238E-06	1.3245E-04	-1.1605E-05	-6.9667E-06
2.2209E-05	4.8406E-02	1.5409E-05	2.3018E-05
1.8528E-03	-7.7111E-01	7.4734E-02	9.7520E-03

TIME = 0.10600E+02

RICCATI SOLUTION MATRIX

3.6263E+01	6.2630E-01	-2.5415E+00	1.6968E+00	2.1285E-01	8.9492E-03	2.6401E-01	-1.8537E-05	1.4164E-04	8.2291E-02
6.2629E-01	4.1405E+00	9.6646E-01	1.9293E+00	4.7424E-01	1.0005E-02	3.2381E-01	-5.4107E-05	8.1153E-04	1.1006E-01
-2.5415E+00	9.6648E-01	3.1100E+00	1.0352E+00	4.9272E-01	1.2955E-03	2.2262E-01	-6.7880E-04	2.0460E-03	9.3480E-01
1.6968E+00	1.9293E+00	1.0352E+00	1.3372E+00	3.5834E-01	6.7672E-03	2.2662E-01	-4.6981E-05	7.5109E-04	7.9998E-02
2.1285E-01	4.7424E-01	4.9272E-01	3.5834E-01	1.3313E-01	1.6877E-03	6.5844E-02	-3.2524E-05	5.8296E-04	3.1171E-02
8.9492E-03	1.0005E-02	1.2955E-03	6.7675E-03	1.6878E-03	5.8403E-03	-2.0217E-02	-2.9018E-06	7.2605E-06	1.7278E-02
2.6401E-01	3.2381E-01	2.2261E-01	2.2662E-01	6.5843E-02	-2.0217E-02	2.0212E-01	1.1604E-05	-8.3351E-05	-4.6624E-02
-1.8527E-05	-5.4022E-05	-6.7880E-04	-4.6900E-05	-3.2513E-05	-2.9020E-06	1.1620E-05	2.8883E-05	-4.9912E-04	-1.0301E-02
1.4106E-04	8.0972E-04	2.0462E-03	7.4954E-04	5.8277E-04	7.2654E-06	-8.3670E-05	-4.9912E-04	1.0942E-02	1.1665E-01
8.2287E-02	1.1005E-01	9.3479E-01	7.9979E-02	3.1169E-02	1.7278E-02	-4.6627E-02	-1.0301E-02	1.1665E-01	7.3767E+00

KE, THE TRANSIENT ESTIMATE GAIN MATRIX

3.1834E-02	1.7120E-02	1.1075E-01	9.1013E-03
4.0068E-02	2.3088E-02	1.3098E-01	2.2650E-02
2.5471E-02	-8.5167E-02	6.2132E-02	3.1712E-02
2.8265E-02	1.6796E-02	9.0491E-02	1.7667E-02
8.1927E-03	6.2981E-03	2.4900E-02	6.5414E-03
1.4095E-04	3.5444E-03	2.4147E-02	5.1025E-05
4.8753E-03	-9.1037E-03	-5.0552E-02	3.4352E-03
-1.3238E-06	1.3245E-04	-1.1605E-05	-6.9667E-06
2.2210E-05	4.8406E-02	1.5410E-05	2.3018E-05
1.8530E-03	-7.7111E-01	7.4735E-02	9.7521E-03

TIME = 0.10800E+02

3.0277E+01	6.1985E-01	-2.5377E+00	1.6978E+00	2.1311E-01	8.9543E-03	2.6417E-01	-1.8556E-05	1.4160E-04	8.2352E-02
6.1985E-01	4.1504E+00	9.6219E-01	1.9281E+00	4.7389E-01	9.9989E-03	3.2361E-01	-5.4096E-05	8.1147E-04	1.1000E-01
-2.5377E+00	9.6221E-01	3.1118E+00	1.0357E+00	4.9286E-01	1.2981E-03	2.2270E-01	-6.7880E-04	2.0460E-03	9.3482E-01
1.6978E+00	1.9281E+00	1.0357E+00	1.3374E+00	3.5838E-01	6.7680E-03	2.2665E-01	-4.6983E-05	7.5109E-04	8.0007E-02
2.1311E-01	4.7390E-01	4.9286E-01	3.5838E-01	1.3314E-01	1.6880E-03	6.5851E-02	-3.2524E-05	5.8296E-04	3.1174E-02
8.9543E-03	9.9991E-03	1.2981E-03	6.7683E-03	1.6880E-03	5.8403E-03	-2.0216E-02	-2.9018E-06	7.2606E-06	1.7278E-02
2.6417E-01	3.2361E-01	2.2270E-01	2.2664E-01	6.5850E-02	-2.0216E-02	2.0213E-01	1.1603E-05	-8.3352E-05	-4.6623E-02
-1.8556E-05	-5.4011E-05	-6.7880E-04	-4.6901E-05	-3.2514E-05	-2.9020E-06	1.1619E-05	2.8883E-05	-4.9912E-04	-1.0301E-02
1.4110E-04	8.0966E-04	2.0462E-03	7.4954E-04	5.8278E-04	7.2654E-06	-8.3669E-05	-4.9912E-04	1.0942E-02	1.1665E-01
8.2335E-02	1.0999E-01	9.3482E-01	7.9994E-02	3.1172E-02	1.7278E-02	-4.6625E-02	-1.0301E-02	1.1665E-01	7.3767E+00

KE, THE TRANSIENT ESTIMATE GAIN MATRIX

3.1854E-02	1.7125E-02	1.1081E-01	9.1155E-03
4.0041E-02	2.3075E-02	1.3090E-01	2.2631E-02
2.5482E-02	-8.5160E-02	6.2166E-02	3.1720E-02
2.8268E-02	1.6798E-02	9.0502E-02	1.7669E-02
8.1936E-03	6.2987E-03	2.4903E-02	6.5421E-03
1.4097E-04	3.5445E-03	2.4147E-02	5.1037E-05
4.8759E-03	-9.1034E-03	-5.0550E-02	3.4356E-03
-1.3239E-06	1.3246E-04	-1.1605E-05	-6.9668E-06
2.2210E-05	4.8406E-02	1.5410E-05	2.3018E-05
1.8531E-03	-7.7111E-01	7.4735E-02	9.7522E-03

TIME = 0.11000E+02

RICCATI SOLUTION MATRIX

3.6253E+01	6.1593E-01	-2.5350E+00	1.6984E+00	2.1329E-01	8.9577E-03	2.6428E-01	-1.8562E-05	1.4187E-04	8.2356E-02
6.1592E-01	4.1590E+00	9.5823E-01	1.9270E+00	4.7358E-01	9.9931E-03	3.2342E-01	-5.4086E-05	8.1145E-04	1.0994E-01
-2.5350E+00	9.5825E-01	3.1135E+00	1.0362E+00	4.9300E-01	1.3007E-03	2.2278E-01	-6.7881E-04	2.0460E-03	9.3485E-01
1.6984E+00	1.9270E+00	1.0362E+00	1.3375E+00	3.5842E-01	6.7687E-03	2.2667E-01	-4.6985E-05	7.5112E-04	8.0011E-02
2.1329E-01	4.7359E-01	4.9300E-01	3.5842E-01	1.3315E-01	1.6882E-03	6.5858E-02	-3.2525E-05	5.8296E-04	3.1175E-02
8.9577E-03	9.9934E-03	1.3006E-03	6.7690E-03	1.6882E-03	5.8403E-03	-2.0216E-02	-2.9018E-06	7.2613E-06	1.7278E-02
2.6428E-01	3.2342E-01	2.2278E-01	2.2667E-01	6.5857E-02	-2.0216E-02	2.0213E-01	1.1603E-05	-8.3349E-05	-4.6622E-02
-1.8542E-05	-5.4000E-05	-6.7881E-04	-4.6903E-05	-3.2514E-05	-2.9020E-06	1.1619E-05	2.8883E-05	-4.9912E-04	-1.0301E-02
1.4114E-04	8.0961E-04	2.0462E-03	7.4955E-04	5.8278E-04	7.2655E-06	-8.3668E-05	-4.9912E-04	1.0942E-02	1.1665E-01
8.2368E-02	1.0994E-01	9.3484E-01	8.0001E-02	3.1173E-02	1.7278E-02	-4.6624E-02	-1.0301E-02	1.1665E-01	7.3767E+00

KE, THE TRANSIENT ESTIMATE GAIN MATRIX

3.1869E-02	1.7130E-02	1.1086E-01	9.1250E-03
4.0018E-02	2.3063E-02	1.3082E-01	2.2614E-02
2.5492E-02	-8.5156E-02	6.2199E-02	3.1728E-02
2.8271E-02	1.6799E-02	9.0511E-02	1.7672E-02
8.1945E-03	6.2988E-03	2.4905E-02	6.5427E-03
1.4098E-04	3.5445E-03	2.4147E-02	5.1049E-05
4.8764E-03	-9.1033E-03	-5.0549E-02	3.4359E-03
-1.3239E-06	1.3245E-04	-1.1605E-05	-6.9668E-06
2.2210E-05	4.8406E-02	1.5410E-05	2.3018E-05
1.8533E-03	-7.7111E-01	7.4736E-02	9.7523E-03

TIME = 0.11200E+02

RICCATI SOLUTION MATRIX

3.6245E+01	6.1415E-01	-2.5333E+00	1.6988E+00	2.1339E-01	8.9598E-03	2.6435E-01	-1.8562E-05	1.4170E-04	8.2379E-02
------------	------------	-------------	------------	------------	------------	------------	-------------	------------	------------

6.1414E-01	4.1666E+00	9.5459E-01	1.9260E+00	4.7331E-01	9.9879E-03	3.2326E-01	-5.4075E-05	8.1136E-04	1.0989E-01
-2.5333E+00	9.5460E-01	3.1151E+00	1.0367E+00	4.9313E-01	1.3031E-03	2.2286E-01	-6.7881E-04	2.0461E-03	9.3487E-01
1.6988E+00	1.9260E+00	1.0367E+00	1.3377E+00	3.5845E-01	6.7694E-03	2.2669E-01	-4.6985E-05	7.5110E-04	8.0019E-02
2.1339E-01	4.7331E-01	4.9313E-01	3.5846E-01	1.3316E-01	1.6883E-03	6.5864E-02	-3.2525E-05	5.8296E-04	3.1177E-02
8.9598E-03	9.9882E-03	1.3031E-03	6.7697E-03	1.6884E-03	5.8403E-03	-2.0216E-02	-2.9018E-06	7.2607E-06	1.7278E-02
2.6435E-01	3.2326E-01	2.2286E-01	2.2669E-01	6.5863E-02	-2.0216E-02	2.0214E-01	1.1603E-05	-8.3351E-05	-4.6621E-02
-1.8546E-05	-5.3991E-05	-6.7881E-04	-4.6904E-05	-3.2515E-05	-2.9020E-06	1.1619E-05	2.8883E-05	-4.9912E-04	-1.0301E-02
1.4115E-04	8.0957E-04	2.0462E-03	7.4955E-04	5.8278E-04	7.2655E-06	-8.3667E-05	-4.9912E-04	1.0942E-02	1.1665E-01
8.2387E-02	1.0989E-01	9.3486E-01	8.0007E-02	3.1175E-02	1.7278E-02	-4.6623E-02	-1.0301E-02	1.1665E-01	7.3767E+00

KE, THE TRANSIENT ESTIMATE GAIN MATRIX

3.1877E-02	1.7131E-02	1.1089E-01	9.1303E-03
3.9996E-02	2.3054E-02	1.3075E-01	2.2598E-02
2.5502E-02	-8.5150E-02	6.2231E-02	3.1735E-02
2.8274E-02	1.6801E-02	9.0520E-02	1.7674E-02
8.1953E-03	6.2993E-03	2.4908E-02	6.5433E-03
1.4100E-04	3.5445E-03	2.4147E-02	5.1059E-05
4.8768E-03	-9.1030E-03	-5.0547E-02	3.4363E-03
-1.3239E-06	1.3246E-04	-1.1605E-05	-6.9668E-06
2.2210E-05	4.8406E-02	1.5411E-05	2.3018E-05
1.8534E-03	-7.7111E-01	7.4736E-02	9.7524E-03

TIME = 0.11400E+02

RICCATI SOLUTION MATRIX

3.6237E+01	6.1416E-01	-2.5324E+00	1.6990E+00	2.1342E-01	8.9607E-03	2.6437E-01	-1.8557E-05	1.4167E-04	8.2388E-02
6.1415E-01	4.1732E+00	9.5125E-01	1.9251E+00	4.7306E-01	9.9832E-03	3.2311E-01	-5.4065E-05	8.1127E-04	1.0985E-01
-2.5324E+00	9.5126E-01	3.1167E+00	1.0371E+00	4.9325E-01	1.3053E-03	2.2293E-01	-6.7882E-04	2.0461E-03	9.3489E-01
1.6990E+00	1.9251E+00	1.0371E+00	1.3378E+00	3.5849E-01	6.7700E-03	2.2671E-01	-4.6985E-05	7.5107E-04	8.0026E-02
2.1342E-01	4.7306E-01	4.9325E-01	3.5849E-01	1.3317E-01	1.6885E-03	6.5869E-02	-3.2525E-05	5.8295E-04	3.1179E-02
8.9607E-03	9.9835E-03	1.3053E-03	6.7703E-03	1.6885E-03	5.8403E-03	-2.0216E-02	-2.9018E-06	7.2606E-06	1.7278E-02
2.6437E-01	3.2311E-01	2.2293E-01	2.2671E-01	6.5868E-02	-2.0216E-02	2.0214E-01	1.1603E-05	-8.3355E-05	-4.6620E-02
-1.8548E-05	-5.3983E-05	-6.7882E-04	-4.6905E-05	-3.2515E-05	-2.9020E-06	1.1619E-05	2.8883E-05	-4.9912E-04	-1.0301E-02
1.4116E-04	8.0953E-04	2.0463E-03	7.4956E-04	5.8278E-04	7.2655E-06	-8.3666E-05	-4.9912E-04	1.0942E-02	1.1665E-01
8.2395E-02	1.0984E-01	9.3488E-01	8.0013E-02	3.1177E-02	1.7278E-02	-4.6622E-02	-1.0301E-02	1.1665E-01	7.3767E+00

KE, THE TRANSIENT ESTIMATE GAIN MATRIX

3.1880E-02	1.7137E-02	1.1090E-01	9.1321E-03
3.9977E-02	2.3044E-02	1.3069E-01	2.2585E-02
2.5511E-02	-8.5146E-02	6.2260E-02	3.1742E-02
2.8277E-02	1.6802E-02	9.0528E-02	1.7675E-02
8.1960E-03	6.2996E-03	2.4910E-02	6.5438E-03
1.4101E-04	3.5445E-03	2.4147E-02	5.1068E-05
4.8773E-03	-9.1028E-03	-5.0546E-02	3.4366E-03
-1.3239E-06	1.3245E-04	-1.1605E-05	-6.9668E-06
2.2210E-05	4.8406E-02	1.5411E-05	2.3018E-05
1.8535E-03	-7.7111E-01	7.4736E-02	9.7525E-03

TIME = 0.11600E+02

RICCATI SOLUTION MATRIX

3.6229E+01	6.1563E-01	-2.5322E+00	1.6990E+00	2.1340E-01	8.9604E-03	2.6436E-01	-1.8560E-05	1.4171E-04	8.2380E-02
6.1562E-01	4.1788E+00	9.4822E-01	1.9243E+00	4.7284E-01	9.9791E-03	3.2298E-01	-5.4058E-05	8.1126E-04	1.0981E-01
-2.5322E+00	9.4824E-01	3.1182E+00	1.0375E+00	4.9337E-01	1.3075E-03	2.2300E-01	-6.7882E-04	2.0461E-03	9.3491E-01

1.6990E+00	1.9243E+00	1.0375E+00	1.3379E+00	3.5852E-01	6.7706E-03	2.2673E-01	-4.6987E-05	7.5110E-04	8.0028E-02
2.1340E-01	4.7284E-01	4.9336E-01	3.5852E-01	1.3318E-01	1.6887E-03	6.5874E-02	-3.2525E-05	5.8296E-04	3.1180E-02
8.9605E-03	9.9793E-03	1.3075E-03	6.7709E-03	1.6887E-03	5.8403E-03	-2.0216E-02	-2.9018E-06	7.2606E-06	1.7278E-02
2.6436E-01	3.2297E-01	2.2300E-01	2.2673E-01	6.5873E-02	-2.0216E-02	2.0214E-01	1.1603E-05	-8.3350E-05	-4.6619E-02
-1.8547E-05	-5.3975E-05	-6.7882E-04	-4.6906E-05	-3.2515E-05	-2.9020E-06	1.1619E-05	2.8883E-05	-4.9912E-04	-1.0301E-02
1.4116E-04	8.0949E-04	2.0463E-03	7.4957E-04	5.8278E-04	7.2657E-06	-8.3665E-05	-4.9912E-04	1.0942E-02	1.1665E-01
8.2393E-02	1.0980E-01	9.3490E-01	8.0019E-02	3.1178E-02	1.7278E-02	-4.6621E-02	-1.0301E-02	1.1665E-01	7.3767E+00

KE, THE TRANSIENT ESTIMATE GAIN MATRIX

3.1879E-02	1.7133E-02	1.1089E-01	9.1307E-03
3.9960E-02	2.3035E-02	1.3064E-01	2.2573E-02
2.5520E-02	-8.5142E-02	6.2288E-02	3.1748E-02
2.8279E-02	1.6802E-02	9.0535E-02	1.7677E-02
8.1966E-03	6.2998E-03	2.4912E-02	6.5442E-03
1.4102E-04	3.5445E-03	2.4147E-02	5.1077E-05
4.8776E-03	-9.1027E-03	-5.0545E-02	3.4368E-03
-1.3240E-06	1.3245E-04	-1.1605E-05	-6.9668E-06
2.2210E-05	4.8406E-02	1.5412E-05	2.3018E-05
1.8537E-03	-7.7111E-01	7.4737E-02	9.7526E-03

TIME = 0.11800E+02

RICCATI SOLUTION MATRIX

3.6222E+01	6.1825E-01	-2.5328E+00	1.6987E+00	2.1333E-01	8.9594E-03	2.6433E-01	-1.8567E-05	1.4187E-04	8.2372E-02
6.1824E-01	4.1837E+00	9.4549E-01	1.9235E+00	4.7265E-01	9.9754E-03	3.2286E-01	-5.4051E-05	8.1124E-04	1.0977E-01
-2.5328E+00	9.4550E-01	3.1197E+00	1.0379E+00	4.9347E-01	1.3095E-03	2.2307E-01	-6.7882E-04	2.0461E-03	9.3493E-01
1.6987E+00	1.9235E+00	1.0379E+00	1.3380E+00	3.5855E-01	6.7711E-03	2.2675E-01	-4.6988E-05	7.5112E-04	8.0034E-02
2.1333E-01	4.7265E-01	4.9347E-01	3.5855E-01	1.3319E-01	1.6888E-03	6.5879E-02	-3.2525E-05	5.8297E-04	3.1181E-02
8.9593E-03	9.9756E-03	1.3095E-03	6.7714E-03	1.6888E-03	5.8403E-03	-2.0216E-02	-2.9019E-06	7.2612E-06	1.7278E-02
2.6433E-01	3.2286E-01	2.2306E-01	2.2674E-01	6.5878E-02	-2.0216E-02	2.0214E-01	1.1602E-05	-8.3347E-05	-4.6618E-02
-1.8545E-05	-5.3968E-05	-6.7882E-04	-4.6907E-05	-3.2515E-05	-2.9020E-06	1.1619E-05	2.8883E-05	-4.9912E-04	-1.0301E-02
1.4115E-04	8.0946E-04	2.0463E-03	7.4957E-04	5.8278E-04	7.2657E-06	-8.3664E-05	-4.9912E-04	1.0942E-02	1.1665E-01
8.2382E-02	1.0977E-01	9.3492E-01	8.0024E-02	3.1180E-02	1.7278E-02	-4.6620E-02	-1.0301E-02	1.1665E-01	7.3767E+00

KE, THE TRANSIENT ESTIMATE GAIN MATRIX

3.1874E-02	1.7132E-02	1.1088E-01	9.1268E-03
3.9945E-02	2.3029E-02	1.3059E-01	2.2562E-02
2.5528E-02	-8.5138E-02	6.2314E-02	3.1754E-02
2.8281E-02	1.6804E-02	9.0542E-02	1.7679E-02
8.1972E-03	6.3003E-03	2.4914E-02	6.5446E-03
1.4103E-04	3.5445E-03	2.4147E-02	5.1085E-05
4.8780E-03	-9.1025E-03	-5.0544E-02	3.4371E-03
-1.3240E-06	1.3245E-04	-1.1605E-05	-6.9668E-06
2.2210E-05	4.8406E-02	1.5412E-05	2.3018E-05
1.8538E-03	-7.7111E-01	7.4737E-02	9.7527E-03

TIME = 0.12000E+02

RICCATI SOLUTION MATRIX

3.6216E+01	6.2176E-01	-2.5339E+00	1.6984E+00	2.1322E-01	8.9574E-03	2.6427E-01	-1.8553E-05	1.4165E-04	8.2366E-02
6.2175E-01	4.1877E+00	9.4305E-01	1.9229E+00	4.7248E-01	9.9721E-03	3.2276E-01	-5.4046E-05	8.1118E-04	1.0974E-01
-2.5339E+00	9.4306E-01	3.1210E+00	1.0383E+00	4.9357E-01	1.3113E-03	2.2312E-01	-6.7883E-04	2.0461E-03	9.3495E-01
1.6984E+00	1.9229E+00	1.0383E+00	1.3381E+00	3.5857E-01	6.7716E-03	2.2676E-01	-4.6985E-05	7.5109E-04	8.0040E-02
2.1322E-01	4.7248E-01	4.9357E-01	3.5857E-01	1.3319E-01	1.6889E-03	6.5883E-02	-3.2526E-05	5.8296E-04	3.1183E-02

8.9574E-03	9.9724E-03	1.3113E-03	6.7719E-03	1.6890E-03	5.8403E-03	-2.0216E-02	-2.9018E-06	7.2606E-06	1.7278E-02
2.6427E-01	3.2275E-01	2.2312E-01	2.2676E-01	6.5882E-02	-2.0216E-02	2.0215E-01	1.1602E-05	-8.3350E-05	-4.6617E-02
-1.8542E-05	-5.3963E-05	-6.7883E-04	-4.6908E-05	-3.2516E-05	-2.9020E-06	1.1618E-05	2.8883E-05	-4.9912E-04	-1.0301E-02
1.4114E-04	8.0943E-04	2.0463E-03	7.4957E-04	5.8278E-04	7.2656E-06	-8.3663E-05	-4.9912E-04	1.0942E-02	1.1665E-01
8.2364E-02	1.0974E-01	9.3494E-01	3.0028E-02	3.1181E-02	1.7278E-02	-4.6620E-02	-1.0301E-02	1.1665E-01	7.3767E+00

KE. THE TRANSIENT ESTIMATE GAIN MATRIX

3.1866E-02	1.7132E-02	1.1085E-01	9.1208E-03
3.9931E-02	2.3021E-02	1.3055E-01	2.2553E-02
2.5536E-02	-8.5135E-02	6.2338E-02	3.1759E-02
2.8283E-02	1.6805E-02	9.0549E-02	1.7680E-02
8.1977E-03	6.3004E-03	2.4915E-02	6.5450E-03
1.4104E-04	3.5445E-03	2.4147E-02	5.1092E-05
4.8783E-03	-9.1024E-03	-5.0543E-02	3.4373E-03
-1.3240E-06	1.3245E-04	-1.1605E-05	-6.9668E-06
2.2210E-05	4.8406E-02	1.5412E-05	2.3019E-05
1.8539E-03	-7.7111E-01	7.4737E-02	9.7528E-03

 RESULTS OF CONTROL PROBLEM

TS, SCALING TRANSFORMATION MATRIX ELEMENTS

2.110E+00 2.592E+00 5.623E+00 1.647E+00 1.647E+00 6.905E-02 7.912E-01 8.274E-04 3.977E-02 4.308E+00
 1.835E+00 1.612E+00 7.713E-01 2.715E+00 2.715E+00 6.585E+01 5.713E+00 5.204E+03 1.083E+02 1.000E+00

REAL PART	IMAGINARY PART	ITER
0.52007685E+00	0.32431795E+00	12
0.52007685E+00	-0.32431795E+00	
-0.52007768E+00	0.32431684E+00	4
-0.52007768E+00	-0.32431684E+00	
0.67386120E+00	0.89368784E+00	6
0.67386120E+00	-0.89368784E+00	
-0.67386044E+00	0.89368755E+00	1
-0.67386044E+00	-0.89368755E+00	
0.48658388E+01	0.	3
-0.48658403E+01	0.	
-0.60440556E+01	0.79257026E+01	6
-0.60440556E+01	-0.79257026E+01	
0.60440561E+01	0.79256955E+01	1
0.60440561E+01	-0.79256955E+01	
-0.40001488E+02	0.30000950E+02	4
-0.40001488E+02	-0.30000950E+02	
0.40001461E+02	0.30000955E+02	4
0.40001461E+02	-0.30000955E+02	
-0.99999240E+02	0.	1
0.99999275E+02	0.	

MODIFIED EIGENVECTOR MATRIX OF AAA

1.7970E-02	-6.7253E-03	-1.1331E-02	-1.0667E-03	2.2864E-03	1.3054E-03	1.9611E-03	-4.5398E-06	-9.4035E-07	-2.8565E-07
-7.1646E-03	9.3256E-03	8.5885E-03	-9.4071E-03	-1.1125E-02	-2.3434E-02	-1.5069E-03	2.0581E-04	-9.8583E-05	2.8565E-05
7.0168E-04	-7.1737E-03	2.6196E-03	1.4015E-02	5.4134E-02	1.5358E-01	-1.7662E-01	-5.4252E-03	1.0238E-02	-2.8565E-03
-4.5725E-03	-7.2893E-03	1.2462E-02	-1.2532E-04	-1.3193E-02	-2.4267E-02	-3.0609E-03	2.1304E-04	-9.7869E-05	2.8767E-05
-4.2416E-05	-1.1088E-03	1.4341E-03	2.2687E-03	3.8017E-01	-2.4335E-02	-1.5299E-02	2.3260E-04	-9.2286E-05	2.9978E-05
-4.7534E-05	-1.0919E-04	2.9784E-04	4.6811E-05	9.4484E-03	-6.1451E-02	-5.3591E-02	1.6133E-07	3.8713E-07	2.2879E-08
6.0135E-05	4.1372E-05	-2.4254E-04	2.3463E-04	-4.5975E-02	7.9616E-01	-1.6313E-01	-1.8068E-05	-1.0646E-05	-2.2879E-06
-9.4011E-08	-2.1772E-07	5.9192E-07	9.8182E-08	1.7605E-05	-1.0653E-04	-1.3029E-04	1.5423E-05	-4.9487E-05	-1.6373E-05
1.1950E-07	8.2742E-08	-4.8661E-07	4.6283E-07	-8.5665E-05	1.6765E-03	-5.6852E-05	8.6771E-04	2.4423E-03	1.6373E-03
-8.8775E-08	-4.0702E-09	-8.4145E-08	-7.4553E-07	4.1683E-04	-9.6821E-03	1.3631E-02	-1.0798E-01	-7.1663E-02	-1.6373E-01
3.0653E-02	3.7627E-03	-5.0038E-03	-8.8539E-03	1.0149E-03	-7.6680E-05	2.1529E-04	7.0912E-08	-4.9208E-08	1.6885E-09
1.9822E-02	2.5320E-02	1.6228E-02	-1.0750E-02	-9.5110E-04	-1.6062E-03	-2.3734E-03	5.5135E-06	1.1944E-06	3.5961E-07
1.1014E-02	1.0409E-02	1.1662E-02	9.9688E-03	1.6243E-02	2.3228E-02	7.2207E-04	-2.0726E-04	9.9099E-05	-2.8447E-05
-4.8920E-03	-9.7595E-03	4.4551E-03	-1.2305E-03	-3.6969E-03	2.9261E-03	4.8666E-04	4.0768E-06	-3.9476E-06	-1.4596E-06
-1.0211E-03	-1.3404E-03	-7.0445E-04	-7.5375E-04	3.7674E-02	2.8309E-03	-8.6602E-04	3.9077E-06	-3.5854E-06	-1.3925E-06
-2.7295E-02	-2.5536E-02	-2.8939E-02	-2.4655E-02	-1.1263E-02	-3.0632E-01	-2.4831E-01	-1.8200E-03	-1.6716E-03	-1.8844E-03
-3.6166E-03	-3.5749E-03	-3.6620E-03	-3.5488E-03	-5.0945E-03	2.9236E-02	-1.0019E-02	-9.8568E-05	-1.1176E-04	-1.0569E-04
1.0000E+00	1.0000E+00	1.0000E+00	1.0000E+00	1.0000E+00	1.0000E+00	1.0000E+00	1.0000E+00	1.0000E+00	1.0000E+00
-4.7855E-02	-4.4323E-02	-5.1652E-02	-4.1767E-02	-7.8248E-02	-1.0911E-01	-2.3629E-03	4.6424E-02	7.0136E-02	5.2044E-02
-7.6818E-04	-7.2361E-04	-8.1607E-04	-6.9135E-04	-1.1474E-03	-1.6688E-03	-4.2614E-05	-2.6562E-04	-4.6884E-05	-3.9802E-04
-3.3739E-03	6.7880E-04	-2.5953E-04	1.2398E-03	-9.0555E-06	-8.8275E-07	-2.8455E-05	0.	0.	0.

```

-1.9733E-03 -7.4020E-04 -1.2828E-03 6.0348E-04 -4.4063E-05 2.2019E-04 -1.7898E-04 -7.0507E-10 1.5307E-09 -1.0578E-10
-7.8619E-04 -1.0249E-03 -1.4038E-03 -7.3980E-04 -2.1440E-04 2.7494E-03 6.6339E-04 -7.4126E-08 4.0077E-08 -1.0578E-08
-1.2173E-03 -5.2044E-04 -9.5338E-04 2.4187E-04 -3.8943E-05 2.1918E-04 -1.6042E-04 -7.0564E-10 1.5080E-09 -1.0504E-10
-3.1615E-04 -1.9626E-04 -3.2374E-04 -2.7821E-05 -2.3154E-05 1.9430E-04 -8.4467E-05 -7.2784E-10 1.3861E-09 -1.0104E-10
1.0140E-05 2.1161E-05 1.7280E-05 3.3272E-05 1.4245E-05 -4.1231E-04 -4.2602E-04 4.0186E-08 -5.6818E-09 7.9555E-09
-1.5893E-06 1.4294E-05 -1.8090E-05 3.7864E-05 6.9315E-05 8.8453E-04 -5.8428E-03 1.7779E-06 9.7833E-07 7.9555E-07
2.0266E-08 4.2537E-08 3.4363E-08 6.7125E-08 2.8990E-08 -8.8506E-07 -8.7662E-07 0. 0. 0.
-3.2555E-09 2.8695E-08 -3.6833E-08 7.5942E-08 1.4106E-07 1.5984E-06 -1.2313E-05 2.9458E-09 3.3459E-10 5.8154E-10
-1.1756E-08 1.3130E-08 -9.1973E-08 1.8880E-08 6.8638E-07 1.0725E-04 -6.1752E-05 1.0819E-07 1.0171E-07 5.8154E-08
6.6536E-03 -1.9866E-03 1.3534E-04 -2.9952E-04 6.3905E-04 4.4105E-04 -2.1915E-04 -1.4768E-08 5.1199E-09 -2.7898E-09
9.0327E-03 1.4958E-02 5.8020E-03 3.2357E-04 2.2977E-03 1.4757E-03 -7.6366E-04 -4.9462E-08 1.7363E-08 -9.3342E-09
1.0068E-02 9.5351E-03 1.0364E-02 8.9238E-03 6.9701E-03 4.6491E-03 -2.2228E-03 -1.6323E-07 5.5122E-08 -3.0867E-08
-4.0703E-03 -1.5955E-02 2.9115E-03 -8.8330E-03 1.1731E-03 -1.9109E-02 -1.6413E-02 3.9433E-06 1.3965E-06 1.5137E-06
-1.2860E-03 -1.4353E-03 -1.1365E-03 -1.5645E-03 -3.3687E-02 -2.8508E-02 -8.0108E-03 4.2820E-06 1.2658E-06 1.5775E-06
-2.4375E-02 -2.2453E-02 -2.5742E-02 -2.0386E-02 -7.6973E-03 1.0000E+00 1.0000E+00 -2.2318E-03 -2.0852E-03 -2.0899E-03
-3.5457E-03 -3.4893E-03 -3.5939E-03 -3.4341E-03 -2.6971E-03 -2.0348E-02 1.4061E-01 -6.7126E-05 -1.0364E-04 -8.9897E-05
1.0000E+00 1.0000E+00 1.0000E+00 1.0000E+00 1.0000E+00 8.4288E-02 9.7657E-02 1.0000E+00 1.0000E+00 1.0000E+00
-4.2321E-02 -3.9177E-02 -4.4084E-02 -3.5582E-02 -2.3736E-02 -1.3372E-02 1.6017E-02 1.4001E-02 3.8000E-02 3.2000E-02
-6.9837E-04 -6.5874E-04 -7.2056E-04 -6.1340E-04 -4.6454E-04 -3.0555E-04 1.8343E-04 4.0014E-05 2.8001E-04 4.0000E-04

```

THE ORDERED EIGENVALUES OF THE HAMILTONIAN MATRIX
 THE ONES WITH NEGATIVE REAL PARTS
 ARE THE EIGENVALUES OF (A-B*KC)

REAL PART	IMAGINARY PART
0.52007685E+00	0.32431795E+00
0.52007685E+00	-0.32431795E+00
0.67386120E+00	0.89368784E+00
0.67386120E+00	-0.89368784E+00
0.48658388E+01	0.
0.60440561E+01	0.79256955E+01
0.60440561E+01	-0.79256955E+01
0.40001461E+02	0.30000955E+02
0.40001461E+02	-0.30000955E+02
0.99999275E+02	0.
-0.52007768E+00	0.32431684E+00
-0.52007768E+00	-0.32431684E+00
-0.67386044E+00	0.89368755E+00
-0.67386044E+00	-0.89368755E+00
-0.48658403E+01	0.
-0.60440566E+01	0.79257026E+01
-0.60440566E+01	-0.79257026E+01
-0.40001488E+02	0.30000950E+02
-0.40001488E+02	-0.30000950E+02
-0.99999240E+02	0.

SS, MATRIX RICCATI SOLUTION FOR CONTROL PROBLEM

```

2.9065E+00 3.5800E+00 2.0447E+00 -5.3504E-01 -1.8421E-01 -5.0969E+00 -6.6756E-01 1.8434E+02 -8.9079E+00 -1.4269E-01
3.5800E+00 7.6643E+00 4.7736E+00 -1.4450E+00 -4.4998E-01 -1.1880E+01 -1.5798E+00 4.3766E+02 -2.0677E+01 -3.3281E-01
2.0447E+00 4.7736E+00 4.1815E+00 -1.1261E+00 -3.9724E-01 -1.0407E+01 -1.4034E+00 3.8976E+02 -1.8008E+01 -2.9126E-01
-5.3504E-01 -1.4450E+00 -1.1261E+00 1.0368E+00 1.3493E-01 2.6979E+00 3.9918E-01 -1.1218E+02 4.7266E+00 7.8090E-02
-1.8421E-01 -4.4998E-01 -3.9724E-01 1.3493E-01 1.4378E-01 9.5328E-01 1.4092E-01 -3.8874E+01 1.6784E+00 2.7581E-02
-5.0969E+00 -1.1880E+01 -1.0407E+01 2.6979E+00 9.5328E-01 3.0529E+01 3.5302E+00 -1.0219E+03 4.3206E+01 7.2586E-01
-6.6756E-01 -1.5798E+00 -1.4034E+00 3.9918E-01 1.4093E-01 3.5302E+00 5.2156E-01 -1.3576E+02 5.9101E+00 9.7624E-02
1.8434E+02 4.3766E+02 3.8976E+02 -1.1218E+02 -3.8874E+01 -1.0219E+03 -1.3576E+02 5.6727E+04 -8.5958E+02 -2.7126E+01
-8.9079E+00 -2.0677E+01 -1.8008E+01 4.7266E+00 1.6784E+00 5.9101E+00 -8.5957E+02 1.2534E+02 1.3332E+00 2.3517E-01
-1.4269E-01 -3.3281E-01 -2.9126E-01 7.8090E-02 2.7581E-02 9.7624E-02 -2.7126E+01 1.3332E+00 2.3517E-02

```

KC, THE CONTROL GAIN MATRIX

5.6802E-01 1.3261E+00 1.1616E+00 -3.1282E-01 -1.1035E-01 -2.8910E+00 -3.8988E-01 1.0828E+02 -5.0027E+00 -8.0913E-02
-6.6756E-01 -1.5798E+00 -1.4034E+00 3.9918E-01 1.4093E-01 3.5302E+00 5.2156E-01 -1.3576E+02 5.9101E+00 9.7624E-02

 TRANSIENT RICCATI SOLUTION

TIME = 0.12000E+02

RICCATI SOLUTION MATRIX

1.0000E+00	0.	0.	0.	0.	0.	0.	0.	0.	0.	0.
0.	1.0000E+00	0.	0.	0.	0.	0.	0.	0.	0.	0.
0.	0.	1.0000E+00	0.	0.	0.	0.	0.	0.	0.	0.
0.	0.	0.	1.0000E+00	0.	0.	0.	0.	0.	0.	0.
0.	0.	0.	0.	1.0000E+00	0.	0.	0.	0.	0.	0.
0.	0.	0.	0.	0.	1.0000E+00	0.	0.	0.	0.	0.
0.	0.	0.	0.	0.	0.	1.0000E+00	0.	0.	0.	0.
0.	0.	0.	0.	0.	0.	0.	1.0000E+00	0.	0.	0.
0.	0.	0.	0.	0.	0.	0.	0.	1.0000E+00	0.	0.
0.	0.	0.	0.	0.	0.	0.	0.	0.	1.0000E+00	0.
0.	0.	0.	0.	0.	0.	0.	0.	0.	0.	1.0000E+00

TIME = 0.11800E+02

RICCATI SOLUTION MATRIX

1.2004E+00	2.2065E-01	1.9648E-02	1.4515E-02	4.7806E-03	-3.4874E-02	-2.0776E-03	2.2398E-01	-1.0936E-01	-1.4190E-03
2.2065E-01	1.2378E+00	1.6827E-01	4.5281E-02	1.4191E-02	-3.3721E-01	-2.3742E-02	6.4685E+00	-8.7767E-01	-1.2135E-02
1.9648E-02	1.6827E-01	1.0414E+00	1.0438E-01	8.9774E-03	-3.3284E+00	-3.4008E-01	9.5008E+01	-4.5197E+00	-7.2640E-02
1.4515E-02	4.5282E-02	1.0438E-01	8.3530E-01	2.7817E-04	-4.0699E-01	-2.0507E-02	3.2802E+00	-5.6010E-01	-7.5862E-03
4.7806E-03	1.4191E-02	8.9774E-03	2.7818E-04	2.2270E-01	-8.3588E-02	2.0231E-03	-1.1064E+00	-7.4159E-02	-7.3582E-04
-3.4874E-02	-3.3721E-01	-3.3284E+00	-4.0699E-01	-8.3588E-02	2.8233E+01	1.9300E+00	-3.6275E+02	1.2717E+01	2.3285E-01
-2.0776E-03	-2.3742E-02	-3.4008E-01	-2.0507E-02	2.0232E-03	1.9300E+00	2.0657E-01	-3.5849E+01	1.3443E+00	2.3596E-02
2.2398E-01	6.4685E+00	9.5008E+01	3.2802E+00	-1.1064E+00	-3.6275E+02	-3.5849E+01	2.5059E+04	4.0665E+02	-6.6028E+00
-1.0936E-01	-8.7767E-01	-4.5197E+00	-5.6010E-01	-7.4159E-02	1.2717E+01	1.3443E+00	4.0665E+02	6.7406E+01	3.9409E-01
-1.4190E-03	-1.2135E-02	-7.2640E-02	-7.5862E-03	-7.3582E-04	2.3285E-01	2.3596E-02	-6.6028E+00	3.9409E-01	8.2957E-03

KC, THE TRANSIENT CONTROL GAIN MATRIX

5.4582E-03	4.6746E-02	2.8931E-01	2.8995E-02	2.4939E-03	-9.2464E-01	-9.4475E-02	2.6393E+01	-1.2556E+00	-2.0179E-02
-2.0778E-03	-2.3742E-02	-3.4008E-01	-2.0507E-02	2.0232E-03	1.9300E+00	2.0657E-01	-3.5849E+01	1.3443E+00	2.3596E-02

TIME = 0.11600E+02

RICCATI SOLUTION MATRIX

1.4006E+00	4.7876E-01	8.3287E-02	2.1263E-02	1.5844E-03	-1.9551E-01	-1.7316E-02	4.5267E+00	-4.1060E-01	-5.9265E-03
4.7876E-01	1.5510E+00	3.7493E-01	5.9034E-02	-1.1452E-04	-9.7173E-01	-9.1646E-02	2.4876E+01	-1.7818E+00	-2.6568E-02
8.3287E-02	3.7493E-01	1.1200E+00	1.0794E-01	-5.4063E-02	-2.9821E+00	-3.9051E-01	1.0181E+02	-4.8685E+00	-7.8153E-02
2.1263E-02	5.9034E-02	1.0794E-01	1.1680E-01	1.8550E-03	-3.3508E-01	-1.2584E-02	4.5318E+00	-5.5955E-01	-7.7863E-03
1.5844E-03	-1.1451E-04	-5.4063E-02	1.8550E-03	1.2341E-01	1.1499E-01	2.9341E-02	-6.4542E+00	2.0769E-01	3.6966E-03
-1.9551E-01	-9.7173E-01	-2.9821E+00	-3.3508E-01	1.1499E-01	1.2519E+01	1.0791E+00	-3.2517E+02	1.1314E+01	2.0898E-01
-1.7316E-02	-9.1647E-02	-3.9051E-01	-1.2584E-02	2.9341E-02	1.0791E+00	1.9592E-01	-4.0745E+01	1.5585E+00	2.7103E-02
4.5267E+00	2.4876E+01	1.0181E+02	4.5317E+00	-6.4542E+00	-3.2516E+02	-4.0745E+01	2.9625E+04	3.7607E+02	-7.0817E+00
-4.1060E-01	-1.7818E+00	-4.8685E+00	-5.5955E-01	2.0769E-01	1.1314E+01	1.5585E+00	3.7607E+02	6.8945E+01	4.1852E-01
-5.9265E-03	-2.6568E-02	-7.8153E-02	-7.7863E-03	3.6966E-03	2.0898E-01	2.7103E-02	-7.0817E+00	4.1852E-01	8.6823E-03

KC, THE TRANSIENT CONTROL GAIN MATRIX

2.3137E-02 1.0416E-01 3.1113E-01 2.9985E-02 -1.5019E-02 -8.2843E-01 -1.0848E-01 2.8282E+01 -1.3525E+00 -2.1711E-02
-1.7316E-02 -9.1647E-02 -3.9051E-01 -1.2584E-02 2.9341E-02 1.0791E+00 1.9592E-01 -4.0745E+01 1.5585E+00 2.7103E-02

TIME = 0.11400E+02

RICCATI SOLUTION MATRIX
1.5995E+00 7.6863E-01 1.8785E-01 1.7933E-02 -4.8555E-03 -4.7225E-01 -4.8778E-02 1.2831E+01 -8.8505E-01 -1.3277E-02
7.6863E-01 1.9396E+00 6.2197E-01 4.1468E-02 -2.1998E-02 -1.6311E+00 -1.7859E-01 4.7092E+01 -2.8593E+00 -4.3813E-02
1.8785E-01 6.2197E-01 1.2414E+00 8.8549E-02 -8.3485E-02 -3.1147E+00 -4.1022E-01 1.1253E+02 -5.4010E+00 -8.6634E-02
1.7933E-02 4.1468E-02 8.8549E-02 6.3677E-01 3.9032E-03 -3.2605E-01 -1.5318E-02 3.3714E+00 -4.6508E-01 -6.4040E-03
-4.8555E-03 -2.1998E-02 -8.3485E-02 3.9032E-03 1.1236E-01 1.6901E-01 3.4242E-02 -9.1742E+00 3.3492E-01 5.7487E-03
-4.7225E-01 -1.6311E+00 -3.1147E+00 -3.2605E-01 1.6901E-01 1.2564E+01 1.0720E+00 -3.3375E+02 1.1947E+01 2.1837E-01
-4.8778E-02 -1.7859E-01 -4.1022E-01 -1.5318E-02 3.4242E-02 1.0720E+00 1.8629E+01 -4.2055E+01 1.6521E+00 2.8499E-02
1.2831E+01 4.7092E+01 1.1253E+02 3.3713E+00 -9.1742E+00 -3.3375E+02 -4.2055E+01 3.0570E+04 3.2892E+02 -7.8312E+00
-8.8505E-01 -2.8593E+00 -5.4010E+00 -4.6508E-01 3.3492E-01 1.1947E+01 1.6521E+00 3.2892E+02 7.1279E+01 4.5571E-01
-1.3277E-02 -4.3813E-02 -8.6634E-02 -6.4039E-03 5.7487E-03 2.1837E-01 2.8499E-02 -7.8312E+00 4.5571E-01 9.2748E-03

KC, THE TRANSIENT CONTROL GAIN MATRIX

5.2186E-02 1.7278E-01 3.4486E-01 2.4599E-02 -2.3192E-02 -8.6525E-01 -1.1396E-01 3.1261E+01 -1.5004E+00 -2.4067E-02
-4.8778E-02 -1.7859E-01 -4.1023E-01 -1.5318E-02 3.4242E-02 1.0720E+00 1.8629E-01 -4.2055E+01 1.6521E+00 2.8499E-02

TIME = 0.11200E+02

RICCATI SOLUTION MATRIX
1.7949E+00 1.0831E+00 3.2905E-01 2.6609E-03 -1.5046E-02 -8.3160E-01 -9.3018E-02 2.4784E+01 -1.5133E+00 -2.3168E-02
1.0831E+00 2.3995E+00 9.1325E-01 -4.0717E-03 -4.8785E-02 -2.3408E+00 -2.7443E-01 7.3495E+01 -4.1261E+00 -6.4136E-02
3.2905E-01 9.1326E-01 1.4083E+00 4.7437E-02 -1.0368E-01 -3.5517E+00 -4.6301E-01 1.2760E+02 -6.1281E+00 -9.8284E-02
2.6610E-03 -4.0717E-03 4.7437E-02 5.8635E-01 7.0089E-03 -1.9845E-01 -2.6975E-03 -1.8827E-02 -2.8046E-01 -3.5178E-03
-1.5046E-02 -4.8785E-02 -1.0368E-01 7.0089E-03 1.1263E-01 2.2785E-01 4.1034E-02 -1.1030E+01 4.2240E-01 7.1573E-03
-8.3160E-01 -2.3408E+00 -3.5517E+00 -1.9845E-01 2.2785E-01 1.3586E+01 1.2058E+00 -3.7287E+02 1.3839E+01 2.4884E-01
-9.3018E-02 -2.7443E-01 -4.6301E-01 -2.6974E-03 4.1034E-02 1.2058E+00 2.0248E-01 -4.6789E+01 1.8825E+00 3.2184E-02
2.4784E+01 7.3495E+01 1.2760E+02 -1.8893E-02 -1.1030E+01 -3.7387E+02 -4.6789E+01 3.1526E+04 2.6224E+02 -8.8828E+00
-1.5133E+00 -4.1261E+00 -6.1281E+00 -2.8045E-01 4.2240E-01 1.3839E+01 1.8825E+00 2.6324E+02 7.4445E+01 5.0645E-01
-2.3168E-02 -6.4136E-02 -9.8284E-02 -3.5178E-03 7.1573E-03 2.4884E-01 3.2184E-02 -8.8828E+00 5.0645E-01 1.0088E-02

KC, THE TRANSIENT CONTROL GAIN MATRIX

9.1411E-02 2.5370E-01 3.9124E-01 1.3178E-02 -2.8804E-02 -9.8667E-01 -1.2862E-01 3.5447E+01 -1.7024E+00 -2.7303E-02
-9.3018E-02 -2.7443E-01 -4.6301E-01 -2.6974E-03 4.1034E-02 1.2058E+00 2.0248E-01 -4.6789E+01 1.8825E+00 3.2184E-02

TIME = 0.11000E+02

RICCATI SOLUTION MATRIX
1.9841E+00 1.4132E+00 5.0007E-01 -2.4722E-02 -2.8711E-02 -1.2630E+00 -1.4770E-01 3.9767E+01 -2.2659E+00 -3.5125E-02
1.4132E+00 2.9216E+00 1.2479E+00 -7.3898E-02 -7.9702E-02 -3.1697E+00 -3.8395E-01 1.0403E+02 -5.5783E+00 -8.7476E-02
5.0007E-01 1.2479E+00 1.6146E+00 -1.4214E-02 -1.2479E-01 -4.0733E+00 -5.3188E-01 1.4648E+02 -7.0220E+00 -1.1267E-01
-2.4722E-02 -7.3898E-02 -1.4213E-02 5.6222E-01 1.2669E-02 -3.6788E-02 1.8154E-02 -5.5403E+00 -1.1064E-02 7.8828E-04
-2.8711E-02 -7.9702E-02 -1.2479E-01 1.2669E-02 1.1461E-01 2.8175E-01 4.8228E-02 -1.2582E+01 5.1354E-01 8.6281E-03
-1.2630E+00 -3.1697E+00 -4.0733E+00 -3.6787E-02 2.8175E-01 1.4902E+01 1.3803E+00 -4.2181E+02 1.6097E+01 2.8520E-01
-1.4770E-01 -3.8395E-01 -5.3188E-01 1.8154E-02 4.8228E-02 1.3803E+00 2.2553E-01 -5.3115E+01 2.1806E+00 3.6986E-02
3.9767E+01 1.0403E+02 1.4648E+02 -5.5403E+00 -1.2582E+01 -4.2181E+02 -5.3115E+01 3.3654E+04 1.8140E+02 -1.0199E+01
-2.2659E+00 -5.5784E+00 -7.0220E+00 -1.1063E-02 5.1354E-01 1.6097E+01 2.1806E+00 1.8140E+02 7.8319E+01 5.6879E-01
-3.5125E-02 -8.7477E-02 -1.1267E-01 7.8829E-04 8.6280E-03 2.8520E-01 3.6986E-02 -1.0199E+01 5.6879E-01 1.1091E-02

KC, THE TRANSIENT CONTROL GAIN MATRIX

1.3892E-01	3.4667E-01	4.4853E-01	-3.9485E-03	-3.4666E-02	-1.1316E+00	-1.4776E-01	4.0692E+01	-1.9507E+00	-3.1299E-02
-1.4770E-01	-3.8395E-01	-5.3188E-01	1.8154E-02	4.8228E-02	1.3803E+00	2.2553E-01	-5.3115E+01	2.1806E+00	3.6986E-02

TIME = 0.10800E+02

RICCATI SOLUTION MATRIX

2.1633E+00	1.7486E+00	6.9232E-01	-6.3345E-02	-4.5248E-02	-1.7466E+00	-2.1026E-01	5.6981E+01	-3.1057E+00	-4.8549E-02
1.7486E+00	3.4905E+00	1.6203E+00	-1.6564E-01	-1.1485E-01	-4.0997E+00	-5.0737E-01	1.3822E+02	-7.1905E+00	-1.1344E-01
6.9232E-01	1.6203E+00	1.8537E+00	-9.2479E-02	-1.4844E-01	-4.6681E+00	-6.1155E-01	1.6855E+02	-8.0555E+00	-1.2933E-01
-6.3345E-02	-1.6564E-01	-9.2479E-02	5.5890E-01	2.0283E-02	1.5814E-01	4.4309E-02	-1.2763E+01	3.2727E-01	6.2440E-03
-4.5248E-02	-1.1485E-01	-1.4844E-01	2.0283E-02	1.1698E-01	3.4041E-01	5.6151E-02	-1.5178E+01	6.1556E-01	1.0276E-02
-1.7466E+00	-4.0997E+00	-4.6681E+00	1.5814E-01	3.4041E-01	1.6381E+01	1.5783E+00	-4.7668E+02	1.8668E+01	3.2666E-01
-2.1026E-01	-5.0737E-01	-6.1155E-01	4.4309E-02	5.6151E-02	1.5783E+00	2.5209E-01	-6.0474E+01	2.5248E+00	4.2538E-02
5.6981E+01	1.3822E+02	1.6855E+02	-1.2763E+01	-1.5178E+01	-4.7668E+02	-6.0474E+01	3.5693E+04	8.6041E+01	-1.1738E+01
-3.1057E+00	-7.1905E+00	-8.0555E+00	3.2727E-01	6.1556E-01	1.8668E+01	2.5248E+00	8.6041E+01	8.2786E+01	6.4081E-01
-4.8549E-02	-1.1344E-01	-1.2933E-01	6.2440E-03	1.0276E-02	3.2666E-01	4.2538E-02	-1.1738E+01	6.4081E-01	1.2252E-02

KC, THE TRANSIENT CONTROL GAIN MATRIX

1.9233E-01	4.5012E-01	5.1497E-01	-2.5691E-02	-4.1238E-02	-1.2968E+00	-1.6989E-01	4.6823E+01	-2.2378E+00	-3.5929E-02
-2.1926E-01	-5.0737E-01	-6.1155E-01	4.4309E-02	5.6151E-02	1.5783E+00	2.5209E-01	-6.0474E+01	2.5248E+00	4.2538E-02

TIME = 0.10600E+02

RICCATI SOLUTION MATRIX

2.3286E+00	2.0776E+00	8.9590E-01	-1.1131E-01	-6.3754E-02	-2.2564E+00	-2.7733E-01	7.5494E+01	-3.9901E+00	-6.2751E-02
2.0776E+00	4.0856E+00	2.0197E+00	-2.7616E-01	-1.5351E-01	-5.0940E+00	-6.4055E-01	1.7514E+02	-8.9159E+00	-1.4127E-01
8.9590E-01	2.0197E+00	2.1180E+00	-1.8380E-01	-1.7466E-01	-5.3243E+00	-6.9989E-01	1.9308E+02	-9.1951E+00	-1.4774E-01
-1.1131E-01	-2.7616E-01	-1.8380E-01	5.7178E-01	2.9456E-02	3.8508E-01	7.5027E-02	-2.1309E+01	7.2003E-01	1.2604E-02
-6.3754E-02	-1.5351E-01	-1.7466E-01	2.9456E-02	1.1962E-01	4.0542E-01	6.4935E-02	-1.7621E+01	7.2846E-01	1.2102E-02
-2.2564E+00	-5.0940E+00	-5.3243E+00	3.8508E-01	4.0542E-01	1.8011E+01	1.7976E+00	-5.3758E+02	2.1498E+01	3.7237E-01
-2.7733E-01	-6.4055E-01	-6.9989E-01	7.5027E-02	6.4935E-02	1.7976E+00	2.8163E-01	-6.8680E+01	2.9057E+00	4.8692E-02
7.5494E+01	1.7514E+02	1.9308E+02	-2.1309E+01	-1.7621E+01	-5.3758E+02	-6.8680E+01	3.7672E+04	-1.9719E+01	-1.3447E+01
-3.9901E+00	-8.9159E+00	-9.1951E+00	7.2003E-01	7.2846E-01	2.1498E+01	2.9057E+00	-1.9719E+01	8.7701E+01	7.2021E-01
-6.2751E-02	-1.4127E-01	-1.4774E-01	1.2604E-02	1.2102E-02	3.7237E-01	4.8692E-02	-1.3447E+01	7.2021E-01	1.3535E-02

KC, THE TRANSIENT CONTROL GAIN MATRIX

2.4888E-01	5.6108E-01	5.8838E-01	-5.1060E-02	-4.8520E-02	-1.4791E+00	-1.9443E-01	5.3638E+01	-2.5544E+00	-4.1043E-02
-2.7733E-01	-6.4055E-01	-6.9989E-01	7.5027E-02	6.4935E-02	1.7976E+00	2.8163E-01	-6.8680E+01	2.9057E+00	4.8692E-02

TIME = 0.10400E+02

RICCATI SOLUTION MATRIX

2.4761E+00	2.3888E+00	1.1074E+00	-1.6581E-01	-8.3145E-02	-2.7667E+00	-3.4531E-01	9.4316E+01	-4.8750E+00	-7.7008E-02
2.3888E+00	4.6825E+00	2.4316E+00	-4.0095E-01	-1.9425E-01	-6.1167E+00	-7.7843E-01	2.1344E+02	-1.0691E+01	-1.6996E-01
1.1074E+00	2.4316E+00	2.3976E+00	-2.8457E-01	-2.0274E-01	-6.0174E+00	-7.9367E-01	2.1516E+02	-1.0399E+01	-1.6721E-01
-1.6581E-01	-4.0095E-01	-2.8457E-01	5.9706E-01	3.9845E-02	6.3491E-01	1.0915E-01	-3.0812E+01	1.1521E+00	1.9618E-02
-8.3145E-02	-1.9425E-01	-2.0274E-01	3.9845E-02	1.2246E-01	4.7501E-01	7.4377E-02	-2.0248E+01	8.4922E-01	1.4057E-02
-2.7667E+00	-6.1167E+00	-6.0174E+00	6.3491E-01	4.7501E-01	1.9729E+01	2.0301E+00	-6.0223E+02	2.4482E+01	4.2065E-01
-3.4531E-01	-7.7843E-01	-7.9367E-01	1.0915E-01	7.4377E-02	2.0301E+00	3.1311E-01	-7.7434E+01	3.3094E+00	5.5223E-02
9.4316E+01	2.1344E+02	2.1516E+02	-3.0812E+01	-2.0248E+01	-6.0223E+02	-7.7434E+01	4.0407E+04	-1.3196E+02	-1.5263E+01

-4.8750E+00 -1.0691E+01 -1.0399E+01 1.1521E+00 8.4922E-01 2.4482E+01 3.3094E+00 -1.3196E+02 9.2882E+01 8.0403E-01
-7.7008E-02 -1.6996E-01 -1.6721E-01 1.9618E-02 1.4057E-02 4.2065E-01 5.5223E-02 -1.5263E+01 8.0403E-01 1.4891E-02

KC, THE TRANSIENT CONTROL GAIN MATRIX

3.0570E-01 6.7550E-01 6.6604E-01 -7.9053E-02 -5.6321E-02 -1.6716E+00 -2.2048E-01 6.0883E+01 -2.8887E+00 -4.6452E-02
-3.4531E-01 -7.7843E-01 -7.9367E-01 1.0915E-01 7.4377E-02 2.0301E+00 3.1311E-01 -7.7434E+01 3.3094E+00 5.5223E-02

TIME = 0.10200E+02

RICCATI SOLUTION MATRIX

2.6028E+00 2.6716E+00 1.2961E+00 -2.2358E-01 -1.0233E-01 -3.2533E+00 -4.1079E-01 1.1249E+02 -5.7184E+00 -9.0637E-02
2.6716E+00 5.2567E+00 2.8391E+00 -5.3438E-01 -2.3537E-01 -7.1269E+00 -9.1545E-01 2.5155E+02 -1.2443E+01 -1.9834E-01
1.2961E+00 2.8391E+00 2.6810E+00 -3.9081E-01 -2.3162E-01 -6.7194E+00 -8.8910E-01 2.4573E+02 -1.1617E+01 -1.8695E-01
-2.2358E-01 -5.3438E-01 -3.9081E-01 6.3135E-01 5.1019E-02 8.9754E-01 1.4525E-01 -4.0884E+01 1.6068E+00 2.7010E-02
-1.0233E-01 -2.3537E-01 -2.3162E-01 5.1019E-02 1.2543E-01 5.4648E-01 8.4117E-02 -2.2561E+01 9.7324E-01 1.6068E-02
-3.2533E+00 -7.1269E+00 -6.7194E+00 8.9754E-01 5.4649E-01 2.1468E+01 2.2664E+00 -6.6800E+02 2.7499E+01 4.6952E-01
-4.1079E-01 -9.1545E-01 -8.8910E-01 1.4525E-01 8.4117E-02 2.2664E+00 3.4525E-01 -8.6381E+01 3.7194E+00 6.1867E-02
1.1249E+02 2.5155E+02 2.4573E+02 -4.0884E+01 -2.2961E+01 -6.6800E+02 -8.6381E+01 4.2898E+04 -2.4610E+02 -1.7112E+01
-5.7184E+00 -1.2443E+01 -1.1617E+01 1.6068E+00 9.7324E-01 2.7499E+01 3.7194E+00 -2.4610E+02 9.8118E+01 8.8885E-01
-9.0637E-02 -1.9834E-01 -1.8695E-01 2.7010E-02 1.6068E-02 4.6952E-01 6.1867E-02 -1.7112E+01 8.8885E-01 1.6265E-02

KC, THE TRANSIENT CONTROL GAIN MATRIX

3.6004E-01 7.8870E-01 7.4479E-01 -1.0857E-01 -6.4344E-02 -1.8666E+00 -2.4699E-01 6.8263E+01 -3.2272E+00 -5.1935E-02
-4.1079E-01 -9.1545E-01 -8.8910E-01 1.4525E-01 8.4117E-02 2.2664E+00 3.4525E-01 -8.6381E+01 3.7194E+00 6.1867E-02

TIME = 0.10000E+02

RICCATI SOLUTION MATRIX

2.7071E+00 2.9182E+00 1.4745E+00 -2.8124E-01 -1.2035E-01 -3.6961E+00 -4.7091E-01 1.2922E+02 -6.4854E+00 -1.0306E-01
2.9182E+00 5.7857E+00 3.2254E+00 -6.7030E-01 -2.7514E-01 -8.0832E+00 -1.0459E+00 2.8791E+02 -1.4102E+01 -2.2523E-01
1.4745E+00 3.2254E+00 2.9565E+00 -4.9832E-01 -2.6011E-01 -7.4007E+00 -9.8216E-01 2.7166E+02 -1.2799E+01 -2.0612E-01
-2.8124E-01 -6.7030E-01 -4.9832E-01 6.7155E-01 6.2504E-02 1.1628E+00 1.8189E-01 -5.1117E+01 2.0663E+00 3.4488E-02
-1.2035E-01 -2.7514E-01 -2.6011E-01 6.2504E-02 1.2839E-01 6.1690E-01 9.3754E-02 -2.5648E+01 1.0954E+00 1.8051E-02
-3.6961E+00 -8.0832E+00 -7.4007E+00 1.1628E+00 6.1690E-01 2.3153E+01 2.4966E+00 -7.3213E+02 3.0422E+01 5.1695E-01
-4.7091E-01 -1.0460E+00 -9.8216E-01 1.8189E-01 9.3754E-02 2.4966E+00 3.7669E-01 -9.5146E+01 4.1186E+00 6.8345E-02
1.2922E+02 2.8791E+02 2.7166E+02 -5.1117E+01 -2.5648E+01 -7.3213E+02 -9.5146E+01 4.5341E+04 -3.5735E+02 -1.8917E+01
-6.4854E+00 -1.4102E+01 -1.2799E+01 2.0663E+00 1.0954E+00 3.0422E+01 4.1186E+00 -3.5735E+02 1.0319E+02 9.7112E-01
-1.0306E-01 -2.2523E-01 -2.0612E-01 3.4488E-02 1.8051E-02 5.1695E-01 6.8345E-02 -1.8917E+01 9.7112E-01 1.7600E-02

KC, THE TRANSIENT CONTROL GAIN MATRIX

4.0962E-01 8.9603E-01 8.2131E-01 -1.3843E-01 -7.2258E-02 -2.0559E+00 -2.7284E-01 7.5467E+01 -3.5555E+00 -5.7261E-02
-4.7091E-01 -1.0460E+00 -9.8216E-01 1.8189E-01 9.3754E-02 2.4966E+00 3.7669E-01 -9.5146E+01 4.1186E+00 6.8345E-02

TIME = 0.98000E+01

RICCATI SOLUTION MATRIX

2.7898E+00 3.1241E+00 1.6298E+00 -3.3583E-01 -1.3646E-01 -4.0806E+00 -5.2355E-01 1.4389E+02 -7.1512E+00 -1.1387E-01
3.1241E+00 6.2527E+00 3.5765E+00 -8.0267E-01 -3.1199E-01 -8.9506E+00 -1.1651E+00 3.2113E+02 -1.5605E+01 -2.4966E-01
1.6298E+00 3.5765E+00 3.2130E+00 -6.0296E-01 -2.8706E-01 -8.0344E+00 -1.0692E+00 2.9593E+02 -1.3898E+01 -2.2398E-01
-3.3583E-01 -8.0268E-01 -6.0296E-01 7.1490E-01 7.3836E-02 1.4205E+00 2.1764E-01 -6.1113E+01 2.5128E+00 4.1765E-02
-1.3646E-01 -3.1199E-01 -2.8706E-01 7.3836E-02 1.3124E-01 6.8342E-01 1.0290E-01 -2.8200E+01 1.2107E+00 1.9926E-02

-4.0806E+00	-8.9506E+00	-8.0344E+00	1.4205E+00	6.8342E-01	2.4718E+01	2.7114E+00	-7.9206E+02	3.3136E+01	5.6104E-01
-5.2355E-01	-1.1651E+00	-1.0692E+00	2.1764E-01	1.0290E-01	2.7114E+00	4.0619E-01	-1.0338E+02	4.4912E+00	7.4398E-02
1.4389E+02	3.2113E+02	2.9593E+02	-6.1113E+01	-2.8200E+01	-7.9206E+02	-1.0338E+02	4.7637E+04	-4.6128E+02	-2.0606E+01
-7.1512E+00	-1.5605E+01	-1.3898E+01	2.5128E+00	1.2107E+00	3.3136E+01	4.4912E+00	-4.6128E+02	1.0790E+02	1.0476E+00
-1.1387E-01	-2.4966E-01	-2.2398E-01	4.1765E-02	1.9926E-02	5.6104E-01	7.4398E-02	-2.0606E+01	1.0476E+00	1.8842E-02

KC, THE TRANSIENT CONTROL GAIN MATRIX

4.5277E-01	9.9355E-01	8.9258E-01	-1.6750E-01	-7.9744E-02	-2.2319E+00	-2.9701E-01	8.2209E+01	-3.8607E+00	-6.2221E-02
-5.2355E-01	-1.1651E+00	-1.0692E+00	2.1764E-01	1.0290E-01	2.7114E+00	4.0619E-01	-1.0338E+02	4.4912E+00	7.4398E-02

TIME = 0.96000E+01

RICCATI SOLUTION MATRIX

2.8495E+00	3.2884E+00	1.7590E+00	-3.8505E-01	-1.5019E-01	-4.3995E+00	-5.6755E-01	1.5617E+02	-7.7030E+00	-1.2286E-01
3.2884E+00	6.6478E+00	3.8823E+00	-9.2631E-01	-3.4473E-01	-9.7046E+00	-1.2693E+00	3.5025E+02	-1.6911E+01	-2.7093E-01
1.7590E+00	3.8823E+00	3.4422E+00	-7.0105E-01	-3.1152E-01	-8.5994E+00	-1.1471E+00	3.1771E+02	-1.4877E+01	-2.3992E-01
-3.8505E-01	-9.2631E-01	-7.0105E-01	7.5897E-01	8.4602E-02	1.6618E+00	2.5124E-01	-7.0518E+01	2.9308E+00	4.8585E-02
-1.5019E-01	-3.4473E-01	-3.1152E-01	8.4602E-02	1.3386E-01	7.4371E-01	1.1123E-01	-3.0527E+01	1.3153E+00	2.1627E-02
-4.3995E+00	-9.7046E+00	-8.5994E+00	1.6617E+00	7.4371E-01	2.6111E+01	2.9037E+00	-8.4578E+02	3.5552E+01	6.0035E-01
-5.6755E-01	-1.2693E+00	-1.1471E+00	2.5124E-01	1.1123E-01	2.9037E+00	4.3273E-01	-1.1079E+02	4.8246E+00	7.9823E-02
1.5617E+02	3.5025E+02	3.1771E+02	-7.0518E+01	-3.0527E+01	-8.4578E+02	-1.1079E+02	4.9708E+04	-5.5440E+02	-2.2122E+01
-7.7030E+00	-1.6911E+01	-1.4877E+01	2.9308E+00	1.3153E+00	3.5552E+01	4.8246E+00	-5.5440E+02	1.1208E+02	1.1157E+00
-1.2286E-01	-2.7093E-01	-2.3992E-01	4.8585E-02	2.1627E-02	6.0035E-01	7.9823E-02	-2.2122E+01	1.1157E+00	1.9951E-02

KC, THE TRANSIENT CONTROL GAIN MATRIX

4.8864E-01	1.0785E+00	9.5624E-01	-1.9475E-01	-8.6539E-02	-2.3889E+00	-3.1867E-01	8.8261E+01	-4.1329E+00	-6.6649E-02
-5.6755E-01	-1.2693E+00	-1.1471E+00	2.5124E-01	1.1123E-01	2.9037E+00	4.3273E-01	-1.1079E+02	4.8246E+00	7.9823E-02

TIME = 0.94000E+01

RICCATI SOLUTION MATRIX

2.8918E+00	3.4133E+00	1.8614E+00	-4.2744E-01	-1.6136E-01	-4.6517E+00	-6.0265E-01	1.6599E+02	-8.1395E+00	-1.2998E-01
3.4133E+00	6.9682E+00	4.1378E+00	-1.0374E+00	-3.7265E-01	-1.0333E+01	-1.3567E+00	3.7472E+02	-1.8001E+01	-2.8870E-01
1.8614E+00	4.1378E+00	3.6386E+00	-7.8978E-01	-3.3284E-01	-9.0830E+00	-1.2142E+00	3.3648E+02	-1.5715E+01	-2.5358E-01
-4.2744E-01	-1.0374E+00	-7.8978E-01	8.0177E-01	9.4471E-02	1.8796E+00	2.8171E-01	-7.9058E+01	3.3084E+00	5.4752E-02
-1.6136E-01	-3.7265E-01	-3.3284E-01	9.4471E-02	1.3618E-01	7.9620E-01	1.1851E-01	-3.2565E+01	1.4063E+00	2.3110E-02
-4.6517E+00	-1.0333E+01	-9.0830E+00	1.8796E+00	7.9620E-01	2.7302E+01	3.0689E+00	-8.9198E+02	3.7616E+01	6.3398E-01
-6.0265E-01	-1.3567E+00	-1.2142E+00	2.8171E-01	1.1851E-01	3.0689E+00	4.5566E-01	-1.1720E+02	5.1109E+00	8.4489E-02
1.6599E+02	3.7472E+02	3.3648E+02	-7.9058E+01	-3.2565E+01	-8.9198E+02	-1.1720E+02	5.1502E+04	-6.3448E+02	-2.3427E+01
-8.1395E+00	-1.8001E+01	-1.5715E+01	3.3084E+00	1.4063E+00	3.7616E+01	5.1109E+00	-6.3448E+02	1.1566E+02	1.1740E+00
-1.2998E-01	-2.8870E-01	-2.5358E-01	5.4752E-02	2.3110E-02	6.3398E-01	8.4489E-02	-2.3427E+01	1.1740E+00	2.0901E-02

KC, THE TRANSIENT CONTROL GAIN MATRIX

5.1709E-01	1.1495E+00	1.0108E+00	-2.1940E-01	-9.2463E-02	-2.5233E+00	-3.3732E-01	9.3474E+01	-4.3657E+00	-7.0443E-02
-6.0265E-01	-1.3567E+00	-1.2142E+00	2.8171E-01	1.1851E-01	3.0689E+00	4.5566E-01	-1.1720E+02	5.1109E+00	8.4489E-02

TIME = 0.92000E+01

RICCATI SOLUTION MATRIX

2.9188E+00	3.5034E+00	1.9388E+00	-4.6239E-01	-1.7004E-01	-4.8418E+00	-6.2935E-01	1.7348E+02	-8.4683E+00	-1.3535E-01
3.5034E+00	7.2173E+00	4.3427E+00	-1.1336E+00	-3.9553E-01	-1.0836E+01	-1.4272E+00	3.9448E+02	-1.8872E+01	-3.0293E-01

1.9388E+00	4.3427E+00	3.8003E+00	-8.6733E-01	-3.5072E-01	-9.4803E+00	-1.2697E+00	3.5202E+02	-1.6404E+01	-2.6482E-01
-4.6239E-01	-1.1336E+00	-8.6733E-01	8.4182E-01	1.0322E-01	2.0698E+00	3.0843E-01	-8.6552E+01	3.6378E+00	6.0141E-02
-1.7094E-01	-3.9553E-01	-3.5072E-01	1.0322E-01	1.3815E-01	8.4014E-01	1.2465E-01	-3.4283E+01	1.4824E+00	2.4353E-02
-4.8418E+00	-1.0836E+01	-9.4803E+00	2.0698E+00	8.4014E-01	2.8278E+01	3.2052E+00	-9.3015E+02	3.9307E+01	6.6160E-01
-6.2935E-01	-1.4272E+00	-1.2697E+00	3.0843E-01	1.2465E-01	3.2052E+00	4.7469E-01	-1.2253E+02	5.3471E+00	8.8345E-02
1.7348E+02	3.9448E+02	3.5202E+02	-8.6552E+01	-3.4283E+01	-9.3015E+02	-1.2253E+02	5.2594E+04	-7.0064E+02	-2.4507E+01
-8.4682E+00	-1.8872E+01	-1.6404E+01	3.6378E+00	1.4824E+00	3.9307E+01	5.3471E+00	-7.0064E+02	1.1859E+02	1.2219E+00
-1.3535E-01	-3.0293E-01	-2.6482E-01	6.0141E-02	2.4353E-02	6.6160E-01	8.8345E-02	-2.4507E+01	1.2219E+00	2.1682E-02

KC, THE TRANSIENT CONTROL GAIN MATRIX

5.3859E-01	1.2064E+00	1.0557E+00	-2.4094E-01	-9.7431E-02	-2.6336E+00	-3.5273E-01	9.7790E+01	-4.5570E+00	-7.3566E-02
-6.2935E-01	-1.4272E+00	-1.2697E+00	3.0843E-01	1.2465E-01	3.2052E+00	4.7469E-01	-1.2253E+02	5.3471E+00	8.8345E-02

TIME = 0.90000E+01

RICCATI SOLUTION MATRIX

2.9341E+00	3.5645E+00	1.9943E+00	-4.9001E-01	-1.7646E-01	-4.9777E+00	-6.4864E-01	1.7890E+02	-8.7031E+00	-1.3921E-01
3.5645E+00	7.4026E+00	4.5003E+00	-1.2142E+00	-4.1357E-01	-1.1223E+01	-1.4818E+00	4.0980E+02	-1.9540E+01	-3.1389E-01
1.9943E+00	4.5003E+00	3.9282E+00	-9.3295E-01	-3.6515E-01	-9.7939E+00	-1.3138E+00	3.6438E+02	-1.6947E+01	-2.7370E-01
-4.9001E-01	-1.2142E+00	-9.3295E-01	8.7811E-01	1.1073E-01	2.2304E+00	3.3111E-01	-9.2522E+01	3.9162E+00	6.4699E-02
-1.7646E-01	-4.1357E-01	-3.6515E-01	1.1073E-01	1.3978E-01	8.7552E-01	1.2962E-01	-3.5677E+01	1.5437E+00	2.5356E-02
-4.9777E+00	-1.1223E+01	-9.7939E+00	2.2304E+00	8.7552E-01	2.9047E+01	3.3133E+00	-9.6047E+02	4.0640E+01	6.8339E-01
-6.4864E-01	-1.4818E+00	-1.3138E+00	3.3111E-01	1.2962E-01	3.3133E+00	4.8987E-01	-1.2679E+02	5.5344E+00	9.1408E-02
1.7890E+02	4.0980E+02	3.6438E+02	-9.2522E+01	-3.5677E+01	-9.6047E+02	-1.2679E+02	5.4189E+04	-7.5317E+02	-2.5366E+01
-8.7031E+00	-1.9540E+01	-1.6947E+01	3.9162E+00	1.5437E+00	5.5344E+01	5.5344E+00	-7.5317E+02	1.2090E+02	1.2596E+00
-1.3921E-01	-3.1389E-01	-2.7370E-01	6.4699E-02	2.5356E-02	6.8339E-01	9.1408E-02	-2.5366E+01	1.2596E+00	2.2299E-02

KC, THE TRANSIENT CONTROL GAIN MATRIX

5.5491E-01	1.2592E+00	1.0912E+00	-2.5917E-01	-1.0144E-01	-2.7207E+00	-3.6497E-01	1.0123E+02	-4.7079E+00	-7.6034E-02
-6.4864E-01	-1.4818E+00	-1.3138E+00	3.3111E-01	1.2962E-01	3.3133E+00	4.8987E-01	-1.2679E+02	5.5344E+00	9.1408E-02

TIME = 0.88000E+01

RICCATI SOLUTION MATRIX

2.9409E+00	3.6027E+00	2.0317E+00	-5.1089E-01	-1.8097E-01	-5.0690E+00	-6.6177E-01	1.8260E+02	-8.8609E+00	-1.4181E-01
3.6027E+00	7.5342E+00	4.6166E+00	-1.2795E+00	-4.2724E-01	-1.1506E+01	-1.5222E+00	4.2119E+02	-2.0032E+01	-3.2196E-01
2.0317E+00	4.6166E+00	4.0253E+00	-9.8676E-01	-3.7636E-01	-1.0031E+01	-1.3474E+00	3.7384E+02	-1.7359E+01	-2.8045E-01
-5.1089E-01	-1.2795E+00	-9.8676E-01	9.1007E-01	1.1700E-01	2.3618E+00	3.4978E-01	-9.8170E+01	4.1440E+00	6.8436E-02
-1.8097E-01	-4.2724E-01	-3.7636E-01	1.1700E-01	1.4107E-01	9.0295E-01	1.3349E-01	-3.6766E+01	1.5912E+00	2.6134E-02
-5.0690E+00	-1.1506E+01	-1.0031E+01	2.3618E+00	9.0295E-01	2.9628E+01	3.3956E+00	-9.8360E+02	4.1646E+01	6.9989E-01
-6.6177E-01	-1.5222E+00	-1.3474E+00	3.4978E-01	1.3349E-01	3.3956E+00	5.0153E-01	-1.3006E+02	5.6769E+00	9.3745E-02
1.8260E+02	4.2119E+02	3.7384E+02	-9.8170E+01	-3.6766E+01	-9.8360E+02	-1.3006E+02	5.5109E+04	-7.9324E+02	-2.6022E+01
-8.8609E+00	-2.0032E+01	-1.7359E+01	4.1440E+00	1.5912E+00	4.1646E+01	5.6769E+00	-7.9324E+02	1.2264E+02	1.2882E+00
-1.4181E-01	-3.2196E-01	-2.8045E-01	6.8436E-02	2.6134E-02	6.9989E-01	9.3745E-02	-2.6022E+01	1.2882E+00	2.2768E-02

KC, THE TRANSIENT CONTROL GAIN MATRIX

5.6441E-01	1.2825E+00	1.1182E+00	-2.7412E-01	-1.0455E-01	-2.7867E+00	-3.7432E-01	1.0385E+02	-4.8222E+00	-7.7909E-02
-6.6177E-01	-1.5222E+00	-1.3474E+00	3.4978E-01	1.3349E-01	3.3956E+00	5.0153E-01	-1.3006E+02	5.6769E+00	9.3745E-02

TIME = 0.86000E+01

RICCATI SOLUTION MATRIX

2.9419E+00	3.6238E+00	2.0551E+00	-5.2594E-01	-1.8393E-01	-5.1255E+00	-6.7007E-01	1.8495E+02	-8.9585E+00	-1.4343E-01
3.6238E+00	7.6228E+00	4.6984E+00	-1.3309E+00	-4.3719E-01	-1.1705E+01	-1.5510E+00	4.2929E+02	-2.0376E+01	-3.2764E-01
2.0551E+00	4.6984E+00	4.0960E+00	-1.0296E+00	-3.8473E-01	-1.0204E+01	-1.3721E+00	3.8077E+02	-1.7657E+01	-2.8535E-01
-5.2594E-01	-1.3309E+00	-1.0296E+00	9.3751E-01	1.2207E-01	2.4662E+00	3.6468E-01	-1.0237E+02	4.3248E+00	7.1407E-02
-1.8393E-01	-4.3719E-01	-3.8473E-01	1.2207E-01	1.4205E-01	9.2337E-01	1.3641E-01	-3.7585E+01	1.6266E+00	2.6715E-02
-5.1255E+00	-1.1705E+01	-1.0204E+01	2.4662E+00	9.2337E-01	3.0049E+01	3.4556E+00	-1.0005E+03	4.2374E+01	7.1185E-01
-6.7007E-01	-1.5510E+00	-1.3721E+00	3.6468E-01	1.3641E-01	3.4556E+00	5.1010E-01	-1.3248E+02	5.7810E+00	9.5455E-02
1.8495E+02	4.2929E+02	3.8077E+02	-1.0237E+02	-3.7585E+01	-1.0005E+03	-1.3248E+02	5.5785E+04	-8.2253E+02	-2.6504E+01
-8.9585E+00	-2.0376E+01	-1.7657E+01	4.3248E+00	1.6266E+00	4.2374E+01	5.7810E+00	-8.2253E+02	1.2390E+02	1.3089E+00
-1.4343E-01	-3.2764E-01	-2.8535E-01	7.1407E-02	2.6715E-02	7.1185E-01	9.5455E-02	-2.6504E+01	1.3089E+00	2.3109E-02

KC, THE TRANSIENT CONTROL GAIN MATRIX

5.7090E-01	1.3052E+00	1.1379E+00	-2.8601E-01	-1.0688E-01	-2.8346E+00	-3.8116E-01	1.0578E+02	-4.9051E+00	-7.9271E-02
-6.7007E-01	-1.5510E+00	-1.3721E+00	3.6468E-01	1.3641E-01	3.4556E+00	5.1010E-01	-1.3248E+02	5.7810E+00	9.5455E-02

TIME = 0.84000E+01

RICCATI SOLUTION MATRIX

2.9393E+00	3.6330E+00	2.0680E+00	-5.3617E-01	-1.8571E-01	-5.1564E+00	-6.7475E-01	1.8628E+02	-9.0118E+00	-1.4432E-01
3.6330E+00	7.6784E+00	4.7530E+00	-1.3702E+00	-4.4410E-01	-1.1837E+01	-1.5703E+00	4.3476E+02	-2.0605E+01	-3.3142E-01
2.0680E+00	4.7530E+00	4.1449E+00	-1.0626E+00	-3.9072E-01	-1.0323E+01	-1.3892E+00	3.8562E+02	-1.7863E+01	-2.8875E-01
-5.3617E-01	-1.3702E+00	-1.0626E+00	9.6055E-01	1.2607E-01	2.5465E+00	3.7623E-01	-1.0562E+02	4.4639E+00	7.3699E-02
-1.8571E-01	-4.4410E-01	-3.9072E-01	1.2607E-01	1.4278E-01	9.3794E-01	1.3850E-01	-3.8176E+01	1.6519E+00	2.7131E-02
-5.1564E+00	-1.1837E+01	-1.0323E+01	2.5465E+00	9.3794E-01	3.0338E+01	3.4974E+00	-1.0123E+03	4.2874E+01	7.2010E-01
-6.7475E-01	-1.5703E+00	-1.3892E+00	3.7623E-01	1.3850E-01	3.4974E+00	5.1613E-01	-1.3418E+02	5.8533E+00	9.6647E-02
1.8628E+02	4.3476E+02	3.8562E+02	-1.0562E+02	-3.8176E+01	-1.0123E+03	-1.3418E+02	5.6269E+04	-8.4296E+02	-2.6840E+01
-9.0118E+00	-2.0605E+01	-1.7863E+01	4.4639E+00	1.6519E+00	4.2874E+01	5.8533E+00	-8.4296E+02	1.2477E+02	1.3232E+00
-1.4432E-01	-3.3142E-01	-2.8875E-01	7.3699E-02	2.7131E-02	7.2010E-01	9.6647E-02	-2.6840E+01	1.3232E+00	2.3344E-02

KC, THE TRANSIENT CONTROL GAIN MATRIX

5.7448E-01	1.3204E+00	1.1515E+00	-2.9519E-01	-1.0854E-01	-2.8677E+00	-3.8593E-01	1.0713E+02	-4.9623E+00	-8.0215E-02
-6.7475E-01	-1.5703E+00	-1.3892E+00	3.7623E-01	1.3850E-01	3.4974E+00	5.1613E-01	-1.3418E+02	5.8533E+00	9.6647E-02

TIME = 0.82000E+01

RICCATI SOLUTION MATRIX

2.9349E+00	3.6342E+00	2.0735E+00	-5.4260E-01	-1.8663E-01	-5.1694E+00	-6.7689E-01	1.8690E+02	-9.0340E+00	-1.4470E-01
3.6342E+00	7.7100E+00	4.7868E+00	-1.3992E+00	-4.4864E-01	-1.1919E+01	-1.5824E+00	4.3821E+02	-2.0745E+01	-3.3376E-01
2.0735E+00	4.7868E+00	4.1769E+00	-1.0872E+00	-3.9480E-01	-1.0400E+01	-1.4006E+00	3.8883E+02	-1.7997E+01	-2.9096E-01
-5.4260E-01	-1.3992E+00	-1.0872E+00	9.7947E-01	1.2912E-01	2.6063E+00	3.8491E-01	-1.0808E+02	4.5676E+00	7.5409E-02
-1.8663E-01	-4.4864E-01	-3.9480E-01	1.2912E-01	1.4329E-01	9.4782E-01	1.3994E-01	-3.8583E+01	1.6690E+00	2.7414E-02
-5.1694E+00	-1.1919E+01	-1.0400E+01	2.6063E+00	9.4782E-01	3.0524E+01	3.5248E+00	-1.0201E+03	4.3197E+01	7.2545E-01
-6.7689E-01	-1.5824E+00	-1.4006E+00	3.8491E-01	1.3994E-01	3.5248E+00	5.2014E-01	-1.3532E+02	5.9008E+00	9.7432E-02
1.8690E+02	4.3821E+02	3.8883E+02	-1.0808E+02	-3.8583E+01	-1.0201E+03	-1.3532E+02	5.6591E+04	-8.5640E+02	-2.7063E+01
-9.0340E+00	-2.0745E+01	-1.7997E+01	4.5676E+00	1.6690E+00	4.3197E+01	5.9008E+00	-8.5640E+02	1.2533E+02	1.3325E+00
-1.4470E-01	-3.3376E-01	-2.9096E-01	7.5409E-02	2.7414E-02	7.2545E-01	9.7432E-02	-2.7063E+01	1.3325E+00	2.3498E-02

KC, THE TRANSIENT CONTROL GAIN MATRIX

5.7602E-01	1.3298E+00	1.1603E+00	-3.0204E-01	-1.0967E-01	-2.8891E+00	-3.8908E-01	1.0802E+02	-4.9995E+00	-8.0830E-02
-6.7689E-01	-1.5824E+00	-1.4006E+00	3.8491E-01	1.3994E-01	3.5248E+00	5.2014E-01	-1.3532E+02	5.9008E+00	9.7432E-02

TIME = 0.8000E+01

RICCATI SOLUTION MATRIX

2.9297E+00	3.6305E+00	2.0743E+00	-5.4617E-01	-1.8696E-01	-5.1707E+00	-6.7732E-01	1.8704E+02	-9.0361E+00	-1.4475E-01
3.6305E+00	7.7249E+00	4.8055E+00	-1.4199E+00	-4.5141E-01	-1.1963E+01	-1.5893E+00	4.4020E+02	-2.0822E+01	-3.3505E-01
2.0743E+00	4.8055E+00	4.1961E+00	-1.1050E+00	-3.9740E-01	-1.0446E+01	-1.4075E+00	3.5080E+02	-1.8076E+01	-2.9229E-01
-5.4617E-01	-1.4199E+00	-1.1050E+00	9.9469E-01	1.3139E-01	2.6492E+00	3.9120E-01	-1.0986E+02	4.6420E+00	7.6642E-02
-1.8696E-01	-4.5141E-01	-3.9740E-01	1.3139E-01	1.4363E-01	9.5409E-01	1.4087E-01	-3.8847E+01	1.6798E+00	2.7594E-02
-5.1707E+00	-1.1963E+01	-1.0446E+01	2.6492E+00	9.5409E-01	3.0634E+01	3.5414E+00	-1.0248E+03	4.3388E+01	7.2864E-01
-6.7732E-01	-1.5893E+00	-1.4075E+00	3.9120E-01	1.4087E-01	3.5414E+00	5.2262E-01	-1.2602E+02	5.9295E+00	9.7910E-02
1.8704E+02	4.4019E+02	3.9080E+02	-1.0986E+02	-3.8847E+01	-1.0248E+03	-1.3602E+02	5.6791E+04	-8.6457E+02	-2.7199E+01
-9.0361E+00	-2.0822E+01	-1.8076E+01	4.6420E+00	1.6798E+00	4.3388E+01	5.9295E+00	-8.6457E+02	1.2566E+02	1.3380E+00
-1.4475E-01	-3.3505E-01	-2.9229E-01	7.6642E-02	2.7594E-02	7.2863E-01	9.7910E-02	-2.7199E+01	1.3380E+00	2.3589E-02

KC, THE TRANSIENT CONTROL GAIN MATRIX

5.7623E-01	1.3350E+00	1.1657E+00	-3.0698E-01	-1.1040E-01	-2.9019E+00	-3.9100E-01	1.0856E+02	-5.0216E+00	-8.1199E-02
-6.7732E-01	-1.5893E+00	-1.4075E+00	3.9120E-01	1.4087E-01	3.5414E+00	5.2262E-01	-1.3602E+02	5.9295E+00	9.7910E-02

TIME = 0.7800E+01

RICCATI SOLUTION MATRIX

2.9245E+00	3.6243E+00	2.0721E+00	-5.4768E-01	-1.8692E-01	-5.1649E+00	-6.7672E-01	1.8688E+02	-9.0260E+00	-1.4460E-01
3.6243E+00	7.7288E+00	4.8139E+00	-1.4341E+00	-4.5291E-01	-1.1982E+01	-1.5926E+00	4.4115E+02	-2.0855E+01	-3.3563E-01
2.0721E+00	4.8139E+00	4.2061E+00	-1.1173E+00	-3.9892E-01	-1.0470E+01	-1.4112E+00	3.5186E+02	-1.8117E+01	-2.9298E-01
-5.4768E-01	-1.4341E+00	-1.1173E+00	1.0067E+00	1.3302E-01	2.6788E+00	3.9559E-01	-1.1111E+02	4.6933E+00	7.7493E-02
-1.8692E-01	-4.5291E-01	-3.9892E-01	1.3302E-01	1.4384E-01	9.5770E-01	1.4142E-01	-3.9004E+01	1.6861E+00	2.7699E-02
-5.1649E+00	-1.1982E+01	-1.0470E+01	2.6788E+00	9.5770E-01	3.0690E+01	3.5502E+00	-1.0273E+03	4.3484E+01	7.3027E-01
-6.7672E-01	-1.5926E+00	-1.4112E+00	3.9559E-01	1.4142E-01	3.5502E+00	5.2399E-01	-1.3641E+02	5.9447E+00	9.8167E-02
1.8688E+02	4.4115E+02	3.9186E+02	-1.1111E+02	-3.9004E+01	-1.0273E+03	-1.3641E+02	5.6904E+04	-8.6895E+02	-2.7273E+01
-9.0260E+00	-2.0855E+01	-1.8117E+01	4.6933E+00	1.6861E+00	4.3484E+01	5.9447E+00	-8.6895E+02	1.2583E+02	1.3408E+00
-1.4460E-01	-3.3563E-01	-2.9298E-01	7.7493E-02	2.7699E-02	7.3027E-01	9.8167E-02	-2.7273E+01	1.3408E+00	2.3637E-02

KC, THE TRANSIENT CONTROL GAIN MATRIX

5.7563E-01	1.3373E+00	1.1685E+00	-3.1039E-01	-1.1082E-01	-2.9085E+00	-3.9203E-01	1.0886E+02	-5.0330E+00	-8.1391E-02
-6.7672E-01	-1.5926E+00	-1.4112E+00	3.9559E-01	1.4142E-01	3.5502E+00	5.2399E-01	-1.3641E+02	5.9447E+00	9.8167E-02

TIME = 0.7600E+01

RICCATI SOLUTION MATRIX

2.9197E+00	3.6171E+00	2.0684E+00	-5.4778E-01	-1.8665E-01	-5.1555E+00	-6.7556E-01	1.8657E+02	-9.0097E+00	-1.4434E-01
3.6171E+00	7.7260E+00	4.8155E+00	-1.4433E+00	-4.5355E-01	-1.1985E+01	-1.5934E+00	4.4141E+02	-2.0860E+01	-3.3573E-01
2.0684E+00	4.8155E+00	4.2099E+00	-1.1254E+00	-3.9966E-01	-1.0478E+01	-1.4127E+00	3.9231E+02	-1.8132E+01	-2.9324E-01
-5.4778E-01	-1.4433E+00	-1.1254E+00	1.0159E+00	1.3414E-01	2.6980E+00	3.9850E-01	-1.1194E+02	4.7266E+00	7.8051E-02
-1.8665E-01	-4.5355E-01	-3.9966E-01	1.3414E-01	1.4396E-01	9.5944E-01	1.4170E-01	-3.9085E+01	1.6891E+00	2.7750E-02
-5.1555E+00	-1.1985E+01	-1.0478E+01	2.6980E+00	9.5944E-01	3.0709E+01	3.5536E+00	-1.0283E+03	4.3517E+01	7.3085E-01
-6.7556E-01	-1.5934E+00	-1.4127E+00	3.9850E-01	1.4170E-01	3.5536E+00	5.2458E-01	-1.3659E+02	5.9507E+00	9.8271E-02
1.8657E+02	4.4141E+02	3.9231E+02	-1.1194E+02	-3.9085E+01	-1.0283E+03	-1.3659E+02	5.6955E+04	-8.7072E+02	-2.7303E+01
-9.0097E+00	-2.0860E+01	-1.8132E+01	4.7266E+00	1.6891E+00	4.3517E+01	5.9507E+00	-8.7072E+02	1.2588E+02	1.3418E+00
-1.4434E-01	-3.3573E-01	-2.9324E-01	7.8051E-02	2.7750E-02	7.3085E-01	9.8271E-02	-2.7303E+01	1.3418E+00	2.3655E-02

KC, THE TRANSIENT CONTROL GAIN MATRIX

5.7461E-01	1.3377E+00	1.1695E+00	-3.1263E-01	-1.1103E-01	-2.9108E+00	-3.9245E-01	1.0898E+02	-5.0371E+00	-8.1463E-02
------------	------------	------------	-------------	-------------	-------------	-------------	------------	-------------	-------------

-6.7556E-01 -1.5934E+00 -1.4127E+00 3.9850E-01 1.4170E-01 3.5536E+00 5.2458E-01 -1.3659E+02 5.9507E+00 9.8271E-02

TIME = 0.74000E+01

RICCATI SOLUTION MATRIX

2.9156E+00	3.6099E+00	2.0642E+00	-5.4698E-01	-1.8629E-01	-5.1449E+00	-6.7418E-01	1.8619E+02	-8.9912E+00	-1.4404E-01
3.6099E+00	7.7195E+00	4.8130E+00	-1.4489E+00	-4.5362E-01	-1.1978E+01	-1.5928E+00	4.4126E+02	-2.0848E+01	-3.3555E-01
2.0642E+00	4.8130E+00	4.2097E+00	-1.1303E+00	-3.9990E-01	-1.0477E+01	-1.4128E+00	3.9236E+02	-1.8130E+01	-2.9323E-01
-5.4698E-01	-1.4489E+00	-1.1303E+00	1.0229E+00	1.3486E-01	2.7096E+00	4.0030E-01	-1.1245E+02	4.7467E+00	7.8389E-02
-1.8629E-01	-4.5362E-01	-3.9990E-01	1.3486E-01	1.4402E-01	9.5994E-01	1.4180E-01	-3.9115E+01	1.6900E+00	2.7766E-02
-5.1449E+00	-1.1978E+01	-1.0477E+01	2.7096E+00	9.5994E-01	3.0705E+01	3.5537E+00	-1.0284E+03	4.3510E+01	7.3077E-01
-6.7418E-01	-1.5928E+00	-1.4128E+00	4.0030E-01	1.4180E-01	3.5537E+00	5.2468E-01	-1.3662E+02	5.9507E+00	9.8277E-02
1.8619E+02	4.4126E+02	3.9236E+02	-1.1245E+02	-3.9115E+01	-1.0284E+03	-1.3662E+02	5.6965E+04	-8.7081E+02	-2.7306E+01
-8.9912E+00	-2.0848E+01	-1.8130E+01	4.7467E+00	1.6900E+00	4.3510E+01	5.9507E+00	-8.7081E+02	1.2587E+02	1.3417E+00
-1.4404E-01	-3.3555E-01	-2.9323E-01	7.8389E-02	2.7766E-02	7.3077E-01	9.8277E-02	-2.7306E+01	1.3417E+00	2.3654E-02

KC, THE TRANSIENT CONTROL GAIN MATRIX

5.7343E-01	1.3370E+00	1.1695E+00	-3.1399E-01	-1.1109E-01	-2.9105E+00	-3.9248E-01	1.0900E+02	-5.0366E+00	-8.1459E-02
-6.7418E-01	-1.5928E+00	-1.4128E+00	4.0030E-01	1.4180E-01	3.5537E+00	5.2468E-01	-1.3662E+02	5.9507E+00	9.8277E-02

TIME = 0.72000E+01

RICCATI SOLUTION MATRIX

2.9123E+00	3.6032E+00	2.0600E+00	-5.4568E-01	-1.8589E-01	-5.1344E+00	-6.7278E-01	1.8580E+02	-8.9730E+00	-1.4375E-01
3.6032E+00	7.7113E+00	4.8083E+00	-1.4519E+00	-4.5336E-01	-1.1966E+01	-1.5914E+00	4.4088E+02	-2.0827E+01	-3.3522E-01
2.0600E+00	4.8083E+00	4.2072E+00	-1.1329E+00	-3.9981E-01	-1.0471E+01	-1.4121E+00	3.9217E+02	-1.8119E+01	-2.9305E-01
-5.4568E-01	-1.4519E+00	-1.1329E+00	1.0280E+00	1.3531E-01	2.7156E+00	4.0129E-01	-1.1274E+02	4.7573E+00	7.8569E-02
-1.8589E-01	-4.5336E-01	-3.9981E-01	1.3530E-01	1.4403E-01	9.5967E-01	1.4178E-01	-3.9112E+01	1.6895E+00	2.7760E-02
-5.1344E+00	-1.1966E+01	-1.0471E+01	2.7156E+00	9.5967E-01	3.0688E+01	3.5517E+00	-1.0279E+03	4.3480E+01	7.3031E-01
-6.7278E-01	-1.5914E+00	-1.4121E+00	4.0129E-01	1.4178E-01	3.5517E+00	5.2447E-01	-1.3657E+02	5.9473E+00	9.8226E-02
1.8580E+02	4.4088E+02	3.9217E+02	-1.1274E+02	-3.9112E+01	-1.0279E+03	-1.3657E+02	5.6951E+04	-8.6991E+02	-2.7293E+01
-8.9730E+00	-2.0827E+01	-1.8119E+01	4.7573E+00	1.6895E+00	4.3480E+01	5.9473E+00	-8.6991E+02	1.2582E+02	1.3409E+00
-1.4375E-01	-3.3522E-01	-2.9305E-01	7.8569E-02	2.7760E-02	7.3031E-01	9.8225E-02	-2.7293E+01	1.3409E+00	2.3641E-02

KC, THE TRANSIENT CONTROL GAIN MATRIX

5.7226E-01	1.3357E+00	1.1688E+00	-3.1472E-01	-1.1107E-01	-2.9087E+00	-3.9228E-01	1.0894E+02	-5.0334E+00	-8.1410E-02
-6.7278E-01	-1.5914E+00	-1.4121E+00	4.0129E-01	1.4178E-01	3.5517E+00	5.2447E-01	-1.3657E+02	5.9473E+00	9.8226E-02

TIME = 0.70000E+01

RICCATI SOLUTION MATRIX

2.9097E+00	3.5974E+00	2.0561E+00	-5.4415E-01	-1.8550E-01	-5.1249E+00	-6.7149E-01	1.8544E+02	-8.9565E+00	-1.4348E-01
3.5974E+00	7.7029E+00	4.8027E+00	-1.4532E+00	-4.5293E-01	-1.1952E+01	-1.5896E+00	4.4039E+02	-2.0802E+01	-3.3484E-01
2.0561E+00	4.8027E+00	4.2036E+00	-1.1340E+00	-3.9954E-01	-1.0461E+01	-1.4109E+00	3.9185E+02	-1.8103E+01	-2.9280E-01
-5.4415E-01	-1.4532E+00	-1.1340E+00	1.0317E+00	1.3554E-01	2.7179E+00	4.0173E-01	-1.1287E+02	4.7613E+00	7.8641E-02
-1.8550E-01	-4.5293E-01	-3.9954E-01	1.3554E-01	1.4401E-01	9.5897E-01	1.4170E-01	-3.9090E+01	1.6883E+00	2.7741E-02
-5.1249E+00	-1.1952E+01	-1.0461E+01	2.7179E+00	9.5897E-01	3.0664E+01	3.5487E+00	-1.0271E+03	4.3440E+01	7.2966E-01
-6.7149E-01	-1.5896E+00	-1.4109E+00	4.0173E-01	1.4170E-01	3.5487E+00	5.2410E-01	-1.3647E+02	5.9422E+00	9.8144E-02
1.8544E+02	4.4039E+02	3.9185E+02	-1.1287E+02	-3.9090E+01	-1.0271E+03	-1.3647E+02	5.6924E+04	-8.6852E+02	-2.7271E+01
-8.9565E+00	-2.0802E+01	-1.8103E+01	4.7613E+00	1.6883E+00	4.3439E+01	5.9422E+00	-8.6852E+02	1.2575E+02	1.3398E+00
-1.4348E-01	-3.3484E-01	-2.9280E-01	7.8641E-02	2.7741E-02	7.2966E-01	9.8144E-02	-2.7271E+01	1.3398E+00	2.3624E-02

KC, THE TRANSIENT CONTROL GAIN MATRIX

5.7120E-01 1.3342E+00 1.1678E+00 -3.1501E-01 -1.1099E-01 -2.9061E+00 -3.9196E-01 1.0886E+02 -5.0290E+00 -8.1340E-02
 -6.7149E-01 -1.5896E+00 -1.4139E+00 4.0173E-01 1.4170E-01 3.5487E+00 5.2410E-01 -1.3647E+02 5.9422E+00 9.8144E-02

TIME = 0.68000E+01

RICCATI SOLUTION MATRIX

2.9078E+00 3.5926E+00 2.0529E+00 -5.4258E-01 -1.8516E-01 -5.1168E+00 -6.7038E-01 1.8513E+02 -8.9424E+00 -1.4325E-01
 3.5926E+00 7.6950E+00 4.7971E+00 -1.4533E+00 -4.5244E-01 -1.1938E+01 -1.5878E+00 4.3988E+02 -2.0778E+01 -3.3445E-01
 2.0529E+00 4.7971E+00 4.1996E+00 -1.1340E+00 -3.9919E-01 -1.0451E+01 -1.4096E+00 3.9149E+02 -1.8086E+01 -2.9252E-01
 -5.4258E-01 -1.4533E+00 -1.1340E+00 1.0343E+00 1.3563E-01 2.7178E+00 4.0180E-01 -1.1290E+02 4.7610E+00 7.8642E-02
 -1.8516E-01 -4.5244E-01 -3.9919E-01 1.3563E-01 1.4399E-01 9.5808E-01 1.4159E-01 -3.9059E+01 1.6868E+00 2.7716E-02
 -5.1168E+00 -1.1938E+01 -1.0451E+01 2.7178E+00 9.5808E-01 3.0639E+01 3.5454E+00 -1.0262E+03 4.3396E+01 7.2896E-01
 -6.7038E-01 -1.5878E+00 -1.4096E+00 4.0180E-01 1.4159E-01 3.5454E+00 5.2367E-01 -1.3635E+02 5.9365E+00 9.8053E-02
 1.8513E+02 4.3988E+02 3.9149E+02 -1.1290E+02 -3.9059E+01 -1.0262E+03 -1.3635E+02 5.6892E+04 -8.6695E+02 -2.7246E+01
 -8.9424E+00 -2.0778E+01 -1.8086E+01 4.7610E+00 1.6868E+00 4.3396E+01 5.9365E+00 -8.6695E+02 1.2567E+02 1.3386E+00
 -1.4325E-01 -3.3445E-01 -2.9252E-01 7.8642E-02 2.7716E-02 7.2896E-01 9.8053E-02 -2.7246E+01 1.3386E+00 2.3604E-02

KC, THE TRANSIENT CONTROL GAIN MATRIX

5.7029E-01 1.3326E+00 1.1667E+00 -3.1502E-01 -1.1089E-01 -2.9034E+00 -3.9159E-01 1.0876E+02 -5.0242E+00 -8.1263E-02
 -6.7038E-01 -1.5878E+00 -1.4096E+00 4.0180E-01 1.4159E-01 3.5454E+00 5.2367E-01 -1.3635E+02 5.9365E+00 9.8053E-02

TIME = 0.66000E+01

RICCATI SOLUTION MATRIX

2.9064E+00 3.5887E+00 2.0502E+00 -5.4110E-01 -1.8487E-01 -5.1102E+00 -6.6947E-01 1.8488E+02 -8.9310E+00 -1.4307E-01
 3.5887E+00 7.6880E+00 4.7920E+00 -1.4527E+00 -4.5195E-01 -1.1925E+01 -1.5860E+00 4.3941E+02 -2.0755E+01 -3.3409E-01
 2.0502E+00 4.7920E+00 4.1958E+00 -1.1334E+00 -3.9882E-01 -1.0442E+01 -1.4083E+00 3.9113E+02 -1.8069E+01 -2.9226E-01
 -5.4110E-01 -1.4527E+00 -1.1334E+00 1.0360E+00 1.3563E-01 2.7161E+00 4.0164E-01 -1.1286E+02 4.7583E+00 7.8601E-02
 -1.8487E-01 -4.5195E-01 -3.9882E-01 1.3563E-01 1.4395E-01 9.5716E-01 1.4147E-01 -3.9025E+01 1.6852E+00 2.7691E-02
 -5.1102E+00 -1.1925E+01 -1.0442E+01 2.7161E+00 9.5716E-01 3.0615E+01 3.5422E+00 -1.0253E+03 4.3355E+01 7.2830E-01
 -6.6947E-01 -1.5860E+00 -1.4083E+00 4.0164E-01 1.4147E-01 3.5422E+00 5.2325E-01 -1.3623E+02 5.9310E+00 9.7964E-02
 1.8488E+02 4.3941E+02 3.9113E+02 -1.1286E+02 -3.9025E+01 -1.0253E+03 -1.3623E+02 5.6859E+04 -8.6541E+02 -2.7221E+01
 -8.9310E+00 -2.0755E+01 -1.8069E+01 4.7583E+00 1.6852E+00 4.3355E+01 5.9310E+00 -8.6541E+02 1.2560E+02 1.3374E+00
 -1.4307E-01 -3.3409E-01 -2.9226E-01 7.8601E-02 2.7691E-02 7.2830E-01 9.7964E-02 -2.7221E+01 1.3374E+00 2.3586E-02

KC, THE TRANSIENT CONTROL GAIN MATRIX

5.6954E-01 1.3312E+00 1.1656E+00 -3.1486E-01 -1.1079E-01 -2.9007E+00 -3.9124E-01 1.0866E+02 -5.0196E+00 -8.1188E-02
 -6.6947E-01 -1.5860E+00 -1.4083E+00 4.0164E-01 1.4147E-01 3.5422E+00 5.2325E-01 -1.3623E+02 5.9310E+00 9.7964E-02

TIME = 0.64000E+01

RICCATI SOLUTION MATRIX

2.9054E+00 3.5857E+00 2.0481E+00 -5.3977E-01 -1.8464E-01 -5.1051E+00 -6.6876E-01 1.8468E+02 -8.9221E+00 -1.4292E-01
 3.5857E+00 7.6820E+00 4.7875E+00 -1.4518E+00 -4.5151E-01 -1.1914E+01 -1.5845E+00 4.3899E+02 -2.0736E+01 -3.3377E-01
 2.0481E+00 4.7875E+00 4.1924E+00 -1.1325E+00 -3.9847E-01 -1.0433E+01 -1.4072E+00 3.9081E+02 -1.8054E+01 -2.9202E-01
 -5.3977E-01 -1.4518E+00 -1.1325E+00 1.0370E+00 1.3558E-01 2.7138E+00 4.0135E-01 -1.1278E+02 4.7542E+00 7.8537E-02
 -1.8464E-01 -4.5151E-01 -3.9847E-01 1.3558E-01 1.4392E-01 9.5629E-01 1.4135E-01 -3.8993E+01 1.6837E+00 2.7667E-02
 -5.1051E+00 -1.1914E+01 -1.0433E+01 2.7138E+00 9.5629E-01 3.0594E+01 3.5394E+00 -1.0245E+03 4.3318E+01 7.2770E-01
 -6.6876E-01 -1.5845E+00 -1.4072E+00 4.0135E-01 1.4135E-01 3.5394E+00 5.2286E-01 -1.3612E+02 5.9260E+00 9.7883E-02
 1.8468E+02 4.3899E+02 3.9081E+02 -1.1278E+02 -3.8993E+01 -1.0245E+03 -1.3612E+02 5.6829E+04 -8.6403E+02 -2.7198E+01

-8.9221E+00 -2.0736E+01 -1.8054E+01 4.7542E+00 1.6837E+00 4.3318E+01 5.9260E+00 -8.6403E+02 1.2554E+02 1.3364E+00
 -1.4292E+01 -3.3377E-01 -2.9202E-01 7.8537E-02 2.7667E-02 7.2770E-01 9.7883E-02 -2.7198E+01 1.3364E+00 2.3569E-02

KC, THE TRANSIENT CONTROL GAIN MATRIX

5.6896E-01 1.3300E+00 1.1646E+00 -3.1461E-01 -1.1070E-01 -2.8983E+00 -3.9091E-01 1.0857E+02 -5.0155E+00 -8.1122E-02
 -6.6876E-01 -1.5845E+00 -1.4072E+00 4.0135E-01 1.4135E-01 3.5394E+00 5.2286E-01 -1.3612E+02 5.9260E+00 9.7883E-02

TIME = 0.62000E+01

RICCATI SOLUTION MATRIX

2.9348E+00 3.5834E+00 2.0465E+00 -5.3862E-01 -1.8446E-01 -5.1012E+00 -6.6822E-01 1.8453E+02 -8.9154E+00 -1.4281E-01
 3.5834E+00 7.6772E+00 4.7837E+00 -1.4507E+00 -4.5112E-01 -1.1904E+01 -1.5833E+00 4.3863E+02 -2.0720E+01 -3.3351E-01
 2.0465E+00 4.7837E+00 4.1895E+00 -1.1315E+00 -3.9817E-01 -1.0426E+01 -1.4062E+00 3.9054E+02 -1.8042E+01 -2.9181E-01
 -5.3862E-01 -1.4507E+00 -1.1315E+00 1.0376E+00 1.3550E-01 2.7112E+00 4.0102E-01 -1.1269E+02 4.7497E+00 7.8465E-02
 -1.8446E-01 -4.5112E-01 -3.9817E-01 1.3550E-01 1.4389E-01 9.5553E-01 1.4125E-01 -3.8964E+01 1.6824E+00 2.7645E-02
 -5.1012E+00 -1.1904E+01 -1.0426E+01 2.7112E+00 9.5553E-01 3.0576E+01 3.5369E+00 -1.0238E+03 4.3287E+01 7.2720E-01
 -6.6822E-01 -1.5833E+00 -1.4062E+00 4.0102E-01 1.4125E-01 3.5369E+00 5.2252E-01 -1.3603E+02 5.9218E+00 9.7815E-02
 1.8453E+02 4.3863E+02 3.9054E+02 -1.1269E+02 -3.8964E+01 -1.0238E+03 -1.3603E+02 5.6803E+04 -8.6285E+02 -2.7179E+01
 -8.9154E+00 -2.0720E+01 -1.8042E+01 4.7497E+00 1.6824E+00 4.3287E+01 5.9218E+00 -8.6285E+02 1.2549E+02 1.3355E+00
 -1.4281E-01 -3.3351E-01 -2.9181E-01 7.8465E-02 2.7645E-02 7.2720E-01 9.7814E-02 -2.7179E+01 1.3355E+00 2.3555E-02

KC, THE TRANSIENT CONTROL GAIN MATRIX

5.6853E-01 1.3289E+00 1.1638E+00 -3.1432E-01 -1.1061E-01 -2.8963E+00 -3.9064E-01 1.0849E+02 -5.0120E+00 -8.1066E-02
 -6.6822E-01 -1.5833E+00 -1.4062E+00 4.0102E-01 1.4125E-01 3.5369E+00 5.2252E-01 -1.3603E+02 5.9218E+00 9.7815E-02

TIME = 0.60000E+01

RICCATI SOLUTION MATRIX

2.9045E+00 3.5817E+00 2.0454E+00 -5.3767E-01 -1.8433E-01 -5.0984E+00 -6.6782E-01 1.8442E+02 -8.9106E+00 -1.4273E-01
 3.5817E+00 7.6733E+00 4.7807E+00 -1.4496E+00 -4.5080E-01 -1.1897E+01 -1.5822E+00 4.3835E+02 -2.0707E+01 -3.3330E-01
 2.0454E+00 4.7807E+00 4.1871E+00 -1.1334E+00 -3.9791E-01 -1.0420E+01 -1.4054E+00 3.9031E+02 -1.8032E+01 -2.9165E-01
 -5.3767E-01 -1.4496E+00 -1.1304E+00 1.0379E+00 1.3541E-01 2.7086E+00 4.0068E-01 -1.1260E+02 4.7452E+00 7.8393E-02
 -1.8433E-01 -4.5080E-01 -3.9791E-01 1.3541E-01 1.4386E-01 9.5490E-01 1.4116E-01 -3.8940E+01 1.6813E+00 2.7627E-02
 -5.0984E+00 -1.1897E+01 -1.0420E+01 2.7086E+00 9.5490E-01 3.0562E+01 3.5349E+00 -1.0232E+03 4.3263E+01 7.2680E-01
 -6.6782E-01 -1.5822E+00 -1.4054E+00 4.0068E-01 1.4116E-01 3.5349E+00 5.2224E-01 -1.3595E+02 5.9183E+00 9.7759E-02
 1.8442E+02 4.3835E+02 3.9031E+02 -1.1260E+02 -3.8940E+01 -1.0232E+03 -1.3595E+02 5.6781E+04 -8.6188E+02 -2.7164E+01
 -8.9106E+00 -2.0707E+01 -1.8032E+01 4.7452E+00 1.6813E+00 4.3263E+01 5.9183E+00 -8.6188E+02 1.2544E+02 1.3348E+00
 -1.4273E-01 -3.3330E-01 -2.9165E-01 7.8393E-02 2.7627E-02 7.2680E-01 9.7758E-02 -2.7164E+01 1.3348E+00 2.3544E-02

KC, THE TRANSIENT CONTROL GAIN MATRIX

5.6821E-01 1.3281E+00 1.1632E+00 -3.1403E-01 -1.1054E-01 -2.8947E+00 -3.9042E-01 1.0843E+02 -5.0092E+00 -8.1020E-02
 -6.6782E-01 -1.5822E+00 -1.4054E+00 4.0068E-01 1.4116E-01 3.5349E+00 5.2224E-01 -1.3595E+02 5.9183E+00 9.7759E-02

TIME = 0.58000E+01

RICCATI SOLUTION MATRIX

2.9044E+00 3.5805E+00 2.0446E+00 -5.3690E-01 -1.8424E-01 -5.0965E+00 -6.6755E-01 1.8434E+02 -8.9073E+00 -1.4268E-01
 3.5805E+00 7.6703E+00 4.7784E+00 -1.4486E+00 -4.5055E-01 -1.1891E+01 -1.5814E+00 4.3813E+02 -2.0697E+01 -3.3314E-01
 2.0446E+00 4.7784E+00 4.1853E+00 -1.1295E+00 -3.9771E-01 -1.0416E+01 -1.4048E+00 3.9013E+02 -1.8024E+01 -2.9152E-01
 -5.3690E-01 -1.4486E+00 -1.1295E+00 1.0380E+00 1.3531E-01 2.7063E+00 4.0036E-01 -1.1251E+02 4.7412E+00 7.8328E-02
 -1.8424E-01 -4.5055E-01 -3.9771E-01 1.3531E-01 1.4384E-01 9.5440E-01 1.4109E-01 -3.8920E+01 1.6804E+00 2.7613E-02

-5.0965E+00	-1.1891E+01	-1.0416E+01	2.7063E+00	9.5440E-01	3.0551E+01	3.5334E+00	-1.0228E+03	4.3243E+01	7.2649E-01
-6.6755E-01	-1.5814E+00	-1.4048E+00	4.0036E-01	1.4109E-01	3.5334E+00	5.2203E-01	-1.3589E+02	5.9156E+00	9.7714E-02
1.8434E+02	4.3813E+02	3.9013E+02	-1.1251E+02	-3.8920E+01	-1.0228E+03	-1.3589E+02	5.6764E+04	-8.6113E+02	-2.7151E+01
-8.9073E+00	-2.0697E+01	-1.8024E+01	4.7412E+00	1.6804E+00	4.3243E+01	5.9156E+00	-8.6113E+02	1.2541E+02	1.3343E+00
-1.4268E-01	-3.3314E-01	-2.9152E-01	7.8328E-02	2.7613E-02	7.2649E-01	9.7714E-02	-2.7151E+01	1.3343E+00	2.3535E-02

KC, THE TRANSIENT CONTROL GAIN MATRIX

5.6799E-01	1.3274E+00	1.1627E+00	-3.1377E-01	-1.1048E-01	-2.8935E+00	-3.9024E-01	1.0838E+02	-5.0070E+00	-8.0985E-02
-6.6755E-01	-1.5814E+00	-1.4048E+00	4.0036E-01	1.4109E-01	3.5334E+00	5.2203E-01	-1.3589E+02	5.9156E+00	9.7714E-02

TIME = 0.56000E+01

RICCATI SOLUTION MATRIX

2.9044E+00	3.5797E+00	2.0441E+00	-5.3630E-01	-1.8417E-01	-5.0953E+00	-6.6737E-01	1.8429E+02	-8.9051E+00	-1.4264E-01
3.5797E+00	7.6681E+00	4.7766E+00	-1.4477E+00	-4.5035E-01	-1.1887E+01	-1.5808E+00	4.3795E+02	-2.0690E+01	-3.3302E-01
2.0441E+00	4.7766E+00	4.1839E+00	-1.1287E+00	-3.9755E-01	-1.0412E+01	-1.4043E+00	3.9000E+02	-1.8018E+01	-2.9142E-01
-5.3630E-01	-1.4477E+00	-1.1287E+00	1.0380E+00	1.3523E-01	2.7042E+00	4.0008E-01	-1.1243E+02	4.7376E+00	7.8270E-02
-1.8417E-01	-4.5035E-01	-3.9755E-01	1.3523E-01	1.4382E-01	9.5401E-01	1.4103E-01	-3.8905E+01	1.6797E+00	2.7602E-02
-5.0953E+00	-1.1887E+01	-1.0412E+01	2.7042E+00	9.5401E+01	3.0542E+01	3.5322E+00	-1.0225E+03	4.3229E+01	7.2625E-01
-6.6737E-01	-1.5808E+00	-1.4043E+00	4.0008E-01	1.4103E-01	3.5322E+00	5.2186E-01	-1.3584E+02	5.9136E+00	9.7681E-02
1.8429E+02	4.3795E+02	3.9000E+02	-1.1243E+02	-3.8905E+01	-1.0225E+03	-1.3584E+02	5.6751E+04	-8.6055E+02	-2.7142E+01
-8.9051E+00	-2.0690E+01	-1.8018E+01	4.7376E+00	1.6797E+00	4.3229E+01	5.9136E+00	-8.6055E+02	1.2538E+02	1.3339E+00
-1.4264E-01	-3.3302E-01	-2.9142E-01	7.8270E-02	2.7602E-02	7.2625E-01	9.7681E-02	-2.7142E+01	1.3339E+00	2.3528E-02

KC, THE TRANSIENT CONTROL GAIN MATRIX

5.6785E-01	1.3269E+00	1.1623E+00	-3.1354E-01	-1.1044E-01	-2.8925E+00	-3.9011E-01	1.0834E+02	-5.0054E+00	-8.0988E-02
-6.6737E-01	-1.5808E+00	-1.4043E+00	4.0008E-01	1.4103E-01	3.5322E+00	5.2186E-01	-1.3584E+02	5.9136E+00	9.7681E-02

TIME = 0.54000E+01

RICCATI SOLUTION MATRIX

2.9045E+00	3.5791E+00	2.0438E+00	-5.3583E-01	-1.8413E-01	-5.0945E+00	-6.6726E-01	1.8426E+02	-8.9038E+00	-1.4262E-01
3.5791E+00	7.6664E+00	4.7753E+00	-1.4470E+00	-4.5020E-01	-1.1884E+01	-1.5804E+00	4.3783E+02	-2.0684E+01	-3.3292E-01
2.0438E+00	4.7753E+00	4.1828E+00	-1.1280E+00	-3.9743E-01	-1.0410E+01	-1.4039E+00	3.8990E+02	-1.8014E+01	-2.9135E-01
-5.3583E-01	-1.4470E+00	-1.1280E+00	1.0378E+00	1.3516E-01	2.7025E+00	3.9985E-01	-1.1237E+02	4.7347E+00	7.8223E-02
-1.8413E-01	-4.5020E-01	-3.9743E-01	1.3516E-01	1.4381E-01	9.5372E-01	1.4099E-01	-3.8893E+01	1.6792E+00	2.7594E-02
-5.0945E+00	-1.1884E+01	-1.0410E+01	2.7025E+00	9.5372E-01	3.0536E+01	3.5313E+00	-1.0222E+03	4.3218E+01	7.2608E-01
-6.6726E-01	-1.5804E+00	-1.4039E+00	4.0008E-01	1.4099E-01	3.5313E+00	5.2174E-01	-1.3581E+02	5.9121E+00	9.7656E-02
1.8426E+02	4.3783E+02	3.8990E+02	-1.1237E+02	-3.8893E+01	-1.0222E+03	-1.3581E+02	5.6741E+04	-8.6013E+02	-2.7135E+01
-8.9038E+00	-2.0684E+01	-1.8014E+01	4.7347E+00	1.6792E+00	4.3218E+01	5.9121E+00	-8.6013E+02	1.2537E+02	1.3336E+00
-1.4262E-01	-3.3292E-01	-2.9135E-01	7.8222E-02	2.7594E-02	7.2608E-01	9.7656E-02	-2.7135E+01	1.3336E+00	2.3523E-02

KC, THE TRANSIENT CONTROL GAIN MATRIX

5.6776E-01	1.3266E+00	1.1620E+00	-3.1335E-01	-1.1041E-01	-2.8918E+00	-3.9001E-01	1.0831E+02	-5.0042E+00	-8.0988E-02
-6.6726E-01	-1.5804E+00	-1.4039E+00	3.9985E-01	1.4099E-01	3.5313E+00	5.2174E-01	-1.3581E+02	5.9121E+00	9.7656E-02

TIME = 0.52000E+01

RICCATI SOLUTION MATRIX

2.9046E+00	3.5788E+00	2.0436E+00	-5.3549E-01	-1.8411E-01	-5.0942E+00	-6.6720E-01	1.8424E+02	-8.9032E+00	-1.4261E-01
3.5788E+00	7.6652E+00	4.7743E+00	-1.4464E+00	-4.5010E-01	-1.1881E+01	-1.5800E+00	4.3774E+02	-2.0680E+01	-3.3286E-01

2.0436E+00	4.7743E+00	4.1821E+00	-1.1274E+00	-3.9734E-01	-1.0408E+01	-1.4037E+00	3.8983E+02	-1.8011E+01	-2.9130E-01
-5.3549E-01	-1.4464E+00	-1.1274E+00	1.0377E+00	1.3510E-01	2.7011E+00	3.9966E-01	-1.1231E+02	4.7323E+00	7.8184E-02
-1.8411E-01	-4.5010E-01	-3.9734E-01	1.3510E-01	1.4380E-01	9.5351E-01	1.4096E-01	-3.8885E+01	1.6788E+00	2.7588E-02
-5.0942E+00	-1.1881E+01	-1.0408E+01	2.7011E+00	9.5351E-01	3.0532E+01	3.5307E+00	-1.0220E+03	4.3211E+01	7.2595E-01
-6.6720E-01	-1.5800E+00	-1.4037E+00	3.9966E-01	1.4096E-01	3.5307E+00	5.2165E-01	-1.3578E+02	5.9110E+00	9.7639E-02
1.8424E+02	4.3774E+02	3.8983E+02	-1.1231E+02	-3.8885E+01	-1.0220E+03	-1.3578E+02	5.6734E+04	-8.5983E+02	-2.7130E+01
-8.9032E+00	-2.0680E+01	-1.8011E+01	4.7323E+00	1.6788E+00	4.3211E+01	5.9110E+00	-8.5983E+02	1.2535E+02	1.3333E+00
-1.4261E-01	-3.3286E-01	-2.9130E-01	7.8184E-02	2.7588E-02	7.2595E-01	9.7639E-02	-2.7130E+01	1.3333E+00	2.3520E-02

KC, THE TRANSIENT CONTROL GAIN MATRIX

5.6772E-01	1.3263E+00	1.1618E+00	-3.1320E-01	-1.1038E-01	-2.8913E+00	-3.8994E-01	1.0829E+02	-5.0033E+00	-8.0924E-02
-6.6720E-01	-1.5800E+00	-1.4037E+00	3.9966E-01	1.4096E-01	3.5307E+00	5.2165E-01	-1.3578E+02	5.9110E+00	9.7639E-02

TIME = 0.50000E+01

RICCATI SOLUTION MATRIX

2.9048E+00	3.5786E+00	2.0436E+00	-5.3524E-01	-1.8410E-01	-5.0940E+00	-6.6718E-01	1.8424E+02	-8.9030E+00	-1.4261E-01
3.5786E+00	7.6643E+00	4.7737E+00	-1.4459E+00	-4.5002E-01	-1.1880E+01	-1.5798E+00	4.3767E+02	-2.0677E+01	-3.3281E-01
2.0436E+00	4.7737E+00	4.1816E+00	-1.1270E+00	-3.9728E-01	-1.0407E+01	-1.4035E+00	3.8978E+02	-1.8008E+01	-2.9127E-01
-5.3524E-01	-1.4459E+00	-1.1270E+00	1.0375E+00	1.3505E-01	2.7001E+00	3.9951E-01	-1.1227E+02	4.7304E+00	7.8153E-02
-1.8410E-01	-4.5002E-01	-3.9728E-01	1.3505E-01	1.4379E-01	9.5336E-01	1.4094E-01	-3.8879E+01	1.6786E+00	2.7584E-02
-5.0940E+00	-1.1880E+01	-1.0407E+01	2.7001E+00	9.5336E-01	3.0529E+01	3.5303E+00	-1.0219E+03	4.3208E+01	7.2587E-01
-6.6718E-01	-1.5798E+00	-1.4035E+00	3.9951E-01	1.4094E-01	3.5303E+00	5.2159E-01	-1.3577E+02	5.9103E+00	9.7627E-02
1.8424E+02	4.3767E+02	3.8978E+02	-1.1227E+02	-3.8879E+01	-1.0219E+03	-1.3577E+02	5.6729E+04	-8.5962E+02	-2.7126E+01
-8.9029E+00	-2.0677E+01	-1.8008E+01	4.7304E+00	1.6786E+00	4.3208E+01	5.9103E+00	-8.5962E+02	1.2534E+02	1.3332E+00
-1.4261E-01	-3.3281E-01	-2.9127E-01	7.8153E-02	2.7584E-02	7.2587E-01	9.7627E-02	-2.7126E+01	1.3332E+00	2.3517E-02

KC, THE TRANSIENT CONTROL GAIN MATRIX

5.6770E-01	1.3261E+00	1.1617E+00	-3.1308E-01	-1.1036E-01	-2.8910E+00	-3.8989E-01	1.0828E+02	-5.0028E+00	-8.0915E-02
-6.6718E-01	-1.5798E+00	-1.4035E+00	3.9951E-01	1.4094E-01	3.5303E+00	5.2159E-01	-1.3577E+02	5.9103E+00	9.7627E-02

TIME = 0.48000E+01

RICCATI SOLUTION MATRIX

2.9050E+00	3.5786E+00	2.0436E+00	-5.3507E-01	-1.8410E-01	-5.0941E+00	-6.6718E-01	1.8424E+02	-8.9030E+00	-1.4261E-01
3.5786E+00	7.6637E+00	4.7733E+00	-1.4456E+00	-4.4997E-01	-1.1879E+01	-1.5797E+00	4.3763E+02	-2.0675E+01	-3.3278E-01
2.0436E+00	4.7732E+00	4.1813E+00	-1.1266E+00	-3.9724E-01	-1.0406E+01	-1.4034E+00	3.8975E+02	-1.8007E+01	-2.9125E-01
-5.3507E-01	-1.4456E+00	-1.1267E+00	1.0374E+00	1.3501E-01	2.6993E+00	3.9939E-01	-1.1224E+02	4.7290E+00	7.8130E-02
-1.8410E-01	-4.4997E-01	-3.9724E-01	1.3501E-01	1.4378E-01	9.5326E-01	1.4093E-01	-3.8874E+01	1.6784E+00	2.7581E-02
-5.0941E+00	-1.1879E+01	-1.0406E+01	2.6993E+00	9.5326E-01	3.0527E+01	3.5300E+00	-1.0219E+03	4.3203E+01	7.2581E-01
-6.6718E-01	-1.5797E+00	-1.4034E+00	3.9939E-01	1.4093E-01	3.5300E+00	5.2155E-01	-1.3576E+02	5.9098E+00	9.7619E-02
1.8424E+02	4.3763E+02	3.8975E+02	-1.1224E+02	-3.8874E+01	-1.0219E+03	-1.3576E+02	5.6726E+04	-8.5949E+02	-2.7124E+01
-8.9030E+00	-2.0675E+01	-1.8007E+01	4.7290E+00	1.6784E+00	4.3203E+01	5.9098E+00	-8.5949E+02	1.2534E+02	1.3331E+00
-1.4261E-01	-3.3278E-01	-2.9125E-01	7.8130E-02	2.7581E-02	7.2581E-01	9.7619E-02	-2.7124E+01	1.3331E+00	2.3516E-02

KC, THE TRANSIENT CONTROL GAIN MATRIX

5.6771E-01	1.3260E+00	1.1616E+00	-3.1298E-01	-1.1035E-01	-2.8908E+00	-3.8986E-01	1.0827E+02	-5.0024E+00	-8.0908E-02
-6.6718E-01	-1.5797E+00	-1.4034E+00	3.9939E-01	1.4093E-01	3.5300E+00	5.2155E-01	-1.3576E+02	5.9098E+00	9.7619E-02

TIME = 0.46000E+01

ORIGINAL PAGE IS
OF POOR QUALITY

RICCATI SOLUTION MATRIX

Table with 10 columns of numerical values in scientific notation, representing the Riccati solution matrix for the first instance.

KC, THE TRANSIENT CONTROL GAIN MATRIX

Table with 10 columns of numerical values in scientific notation, representing the transient control gain matrix for the first instance.

TIME = 0.44000E+01

RICCATI SOLUTION MATRIX

Table with 10 columns of numerical values in scientific notation, representing the Riccati solution matrix for the second instance.

KC, THE TRANSIENT CONTROL GAIN MATRIX

Table with 10 columns of numerical values in scientific notation, representing the transient control gain matrix for the second instance.

TIME = 0.42000E+01

RICCATI SOLUTION MATRIX

Table with 10 columns of numerical values in scientific notation, representing the Riccati solution matrix for the third instance.

KC, THE TRANSIENT CONTROL GAIN MATRIX

Table with 10 columns of numerical values in scientific notation, representing the transient control gain matrix for the third instance.

TIME = 0.40000E+01

RICCATI SOLUTION MATRIX

2.9056E+00	3.5789E+00	2.0439E+00	-5.3482E-01	-1.8413E-01	-5.0949E+00	-6.6729E-01	1.8426E+02	-8.9044E+00	-1.4263E-01
3.5789E+00	7.6630E+00	4.7727E+00	-1.4449E+00	-4.4989E-01	-1.1877E+01	-1.5795E+00	4.3757E+02	-2.0673E+01	-3.3275E-01
2.0439E+00	4.7727E+00	4.1809E+00	-1.1260E+00	-3.9718E-01	-1.0405E+01	-1.4032E+00	3.8971E+02	-1.8006E+01	-2.9122E-01
-5.3482E-01	-1.4449E+00	-1.1260E+00	1.0370E+00	1.3493E-01	2.6977E+00	3.9917E-01	-1.1217E+02	4.7263E+00	7.8086E-02
-1.8413E-01	-4.4989E-01	-3.9718E-01	1.3493E-01	1.4378E-01	9.5313E-01	1.4091E-01	-3.8869E+01	1.6782E+00	2.7577E-02
-5.0949E+00	-1.1877E+01	-1.0405E+01	2.6977E+00	9.5313E-01	3.0525E+01	3.5297E+00	-1.0218E+03	4.3199E+01	7.2575E-01
-6.6729E-01	-1.5795E+00	-1.4032E+00	3.9917E-01	1.4091E-01	3.5297E+00	5.2150E-01	-1.3574E+02	5.9092E+00	9.7609E-02
1.8426E+02	4.3757E+02	3.8971E+02	-1.1217E+02	-3.8869E+01	-1.0218E+03	-1.3574E+02	5.6722E+04	-8.5933E+02	-2.7122E+01
-8.9044E+00	-2.0673E+01	-1.8006E+01	4.7263E+00	1.6782E+00	4.3199E+01	5.9092E+00	-8.5933E+02	1.2533E+02	1.3330E+00
-1.4263E-01	-3.3275E-01	-2.9122E-01	7.8086E-02	2.7577E-02	7.2575E-01	9.7609E-02	-2.7122E+01	1.3330E+00	2.3514E-02

KC, THE TRANSIENT CONTROL GAIN MATRIX

5.6780E-01	1.3259E+00	1.1615E+00	-3.1281E-01	-1.1034E-01	-2.8905E+00	-3.8982E-01	1.0826E+02	-5.0020E+00	-8.0901E-02
-6.6729E-01	-1.5795E+00	-1.4032E+00	3.9917E-01	1.4091E-01	3.5297E+00	5.2150E-01	-1.3574E+02	5.9092E+00	9.7609E-02

TIME = 0.38000E+01

RICCATI SOLUTION MATRIX

2.9058E+00	3.5790E+00	2.0440E+00	-5.3482E-01	-1.8414E-01	-5.0951E+00	-6.6732E-01	1.8427E+02	-8.9049E+00	-1.4264E-01
3.5790E+00	7.6630E+00	4.7727E+00	-1.4448E+00	-4.4989E-01	-1.1877E+01	-1.5795E+00	4.3757E+02	-2.0673E+01	-3.3275E-01
2.0440E+00	4.7727E+00	4.1809E+00	-1.1260E+00	-3.9718E-01	-1.0405E+01	-1.4032E+00	3.8971E+02	-1.8006E+01	-2.9122E-01
-5.3482E-01	-1.4448E+00	-1.1260E+00	1.0369E+00	1.3492E-01	2.6976E+00	3.9915E-01	-1.1217E+02	4.7261E+00	7.8082E-02
-1.8414E-01	-4.4989E-01	-3.9718E-01	1.3492E-01	1.4378E-01	9.5313E-01	1.4091E-01	-3.8869E+01	1.6782E+00	2.7577E-02
-5.0951E+00	-1.1877E+01	-1.0405E+01	2.6976E+00	9.5313E-01	3.0525E+01	3.5297E+00	-1.0218E+03	4.3199E+01	7.2575E-01
-6.6732E-01	-1.5795E+00	-1.4032E+00	3.9915E-01	1.4091E-01	3.5297E+00	5.2150E-01	-1.3574E+02	5.9093E+00	9.7610E-02
1.8427E+02	4.3757E+02	3.8971E+02	-1.1217E+02	-3.8869E+01	-1.0218E+03	-1.3574E+02	5.6722E+04	-8.5933E+02	-2.7122E+01
-8.9049E+00	-2.0673E+01	-1.8006E+01	4.7261E+00	1.6782E+00	4.3199E+01	5.9093E+00	-8.5933E+02	1.2533E+02	1.3330E+00
-1.4264E-01	-3.3275E-01	-2.9122E-01	7.8082E-02	2.7577E-02	7.2575E-01	9.7609E-02	-2.7122E+01	1.3330E+00	2.3514E-02

KC, THE TRANSIENT CONTROL GAIN MATRIX

5.6782E-01	1.3259E+00	1.1615E+00	-3.1279E-01	-1.1034E-01	-2.8906E+00	-3.8982E-01	1.0826E+02	-5.0020E+00	-8.0901E-02
-6.6732E-01	-1.5795E+00	-1.4032E+00	3.9915E-01	1.4091E-01	3.5297E+00	5.2150E-01	-1.3574E+02	5.9093E+00	9.7610E-02

TIME = 0.36000E+01

RICCATI SOLUTION MATRIX

2.9059E+00	3.5791E+00	2.0441E+00	-5.3482E-01	-1.8415E-01	-5.0953E+00	-6.6735E-01	1.8428E+02	-8.9053E+00	-1.4264E-01
3.5791E+00	7.6631E+00	4.7728E+00	-1.4447E+00	-4.4990E-01	-1.1877E+01	-1.5795E+00	4.3758E+02	-2.0673E+01	-3.3275E-01
2.0441E+00	4.7728E+00	4.1810E+00	-1.1259E+00	-3.9719E-01	-1.0405E+01	-1.4033E+00	3.8971E+02	-1.8006E+01	-2.9122E-01
-5.3482E-01	-1.4447E+00	-1.1259E+00	1.0369E+00	1.3492E-01	2.6975E+00	3.9914E-01	-1.1217E+02	4.7260E+00	7.8080E-02
-1.8415E-01	-4.4990E-01	-3.9719E-01	1.3492E-01	1.4378E-01	9.5313E-01	1.4091E-01	-3.8869E+01	1.6782E+00	2.7577E-02
-5.0953E+00	-1.1877E+01	-1.0405E+01	2.6975E+00	9.5313E-01	3.0525E+01	3.5297E+00	-1.0218E+03	4.3200E+01	7.2576E-01
-6.6735E-01	-1.5795E+00	-1.4033E+00	3.9914E-01	1.4091E-01	3.5297E+00	5.2150E-01	-1.3574E+02	5.9093E+00	9.7610E-02
1.8428E+02	4.3758E+02	3.8971E+02	-1.1217E+02	-3.8869E+01	-1.0218E+03	-1.3574E+02	5.6722E+04	-8.5934E+02	-2.7122E+01
-8.9052E+00	-2.0673E+01	-1.8006E+01	4.7260E+00	1.6782E+00	4.3199E+01	5.9093E+00	-8.5934E+02	1.2533E+02	1.3330E+00
-1.4264E-01	-3.3275E-01	-2.9122E-01	7.8080E-02	2.7577E-02	7.2576E-01	9.7610E-02	-2.7122E+01	1.3330E+00	2.3514E-02

KC, THE TRANSIENT CONTROL GAIN MATRIX

5.6785E-01	1.3259E+00	1.1615E+00	-3.1278E-01	-1.1034E-01	-2.8906E+00	-3.8982E-01	1.0826E+02	-5.0020E+00	-8.0902E-02
------------	------------	------------	-------------	-------------	-------------	-------------	------------	-------------	-------------

-6.6735E-01 -1.5795E+00 -1.4033E+00 3.9914E-01 1.4091E-01 3.5297E+00 5.2150E-01 -1.3574E+02 5.9093E+00 9.7610E-02

TIME = 0.34000E+01

RICCATI SOLUTION MATRIX

2.9060E+00 3.5792E+00 2.0442E+00 -5.3484E-01 -1.8415E-01 -5.0956E+00 -6.6738E-01 1.8429E+02 -8.9056E+00 -1.4265E-01
3.5792E+00 7.6632E+00 4.7728E+00 -1.4447E+00 -4.4990E-01 -1.1878E+01 -1.5795E+00 4.3758E+02 -2.0674E+01 -3.3275E-01
2.0442E+00 4.7728E+00 4.1810E+00 -1.1259E+00 -3.9719E-01 -1.0405E+01 -1.4033E+00 3.8971E+02 -1.8006E+01 -2.9123E-01
-5.3484E-01 -1.4447E+00 -1.1259E+00 1.0369E+00 1.3492E-01 2.6975E+00 3.9913E-01 -1.1216E+02 4.7259E+00 7.8079E-02
-1.8415E-01 -4.4990E-01 -3.9719E-01 1.3492E-01 1.4378E-01 9.5314E-01 1.4091E-01 -3.8869E+01 1.6782E+00 2.7577E-02
-5.0956E+00 -1.1878E+01 -1.0405E+01 2.6975E+00 9.5314E-01 3.0526E+01 3.5298E+00 -1.0218E+03 4.3200E+01 7.2577E-01
-6.6738E-01 -1.5795E+00 -1.4033E+00 3.9913E-01 1.4091E-01 3.5298E+00 5.2151E-01 -1.3574E+02 5.9094E+00 9.7611E-02
1.8429E+02 4.3758E+02 3.8971E+02 -1.1216E+02 -3.8869E+01 -1.0218E+03 -1.3574E+02 5.6723E+04 -8.5936E+02 -2.7122E+01
-8.9056E+00 -2.0674E+01 -1.8006E+01 4.7259E+00 1.6782E+00 4.3200E+01 5.9094E+00 -8.5936E+02 1.2533E+02 1.3330E+00
-1.4265E-01 -3.3275E-01 -2.9123E-01 7.8079E-02 2.7577E-02 7.2577E-01 9.7611E-02 -2.7122E+01 1.3330E+00 2.3514E-02

KC, THE TRANSIENT CONTROL GAIN MATRIX

5.6787E-01 1.3259E+00 1.1615E+00 -3.1278E-01 -1.1034E-01 -2.8906E+00 -3.8983E-01 1.0826E+02 -5.0021E+00 -8.0903E-02
-6.6738E-01 -1.5795E+00 -1.4033E+00 3.9913E-01 1.4091E-01 3.5298E+00 5.2151E-01 -1.3574E+02 5.9094E+00 9.7611E-02

TIME = 0.32000E+01

RICCATI SOLUTION MATRIX

2.9061E+00 3.5793E+00 2.0443E+00 -5.3485E-01 -1.8416E-01 -5.0957E+00 -6.6741E-01 1.8430E+02 -8.9060E+00 -1.4266E-01
3.5793E+00 7.6633E+00 4.7729E+00 -1.4447E+00 -4.4991E-01 -1.1878E+01 -1.5795E+00 4.3759E+02 -2.0674E+01 -3.3276E-01
2.0443E+00 4.7729E+00 4.1811E+00 -1.1259E+00 -3.9719E-01 -1.0405E+01 -1.4033E+00 3.8972E+02 -1.8006E+01 -2.9123E-01
-5.3485E-01 -1.4447E+00 -1.1259E+00 1.0368E+00 1.3492E-01 2.6975E+00 3.9913E-01 -1.1216E+02 4.7259E+00 7.8079E-02
-1.8416E-01 -4.4991E-01 -3.9719E-01 1.3492E-01 1.4378E-01 9.5315E-01 1.4091E-01 -3.8870E+01 1.6782E+00 2.7578E-02
-5.0957E+00 -1.1878E+01 -1.0405E+01 2.6975E+00 9.5315E-01 3.0526E+01 3.5298E+00 -1.0218E+03 4.3201E+01 7.2578E-01
-6.6741E-01 -1.5795E+00 -1.4033E+00 3.9913E-01 1.4091E-01 3.5298E+00 5.2151E-01 -1.3575E+02 5.9094E+00 9.7612E-02
1.8430E+02 4.3759E+02 3.8972E+02 -1.1216E+02 -3.8870E+01 -1.0218E+03 -1.3575E+02 5.6723E+04 -8.5938E+02 -2.7122E+01
-8.9060E+00 -2.0674E+01 -1.8006E+01 4.7259E+00 1.6782E+00 4.3201E+01 5.9094E+00 -8.5938E+02 1.2533E+02 1.3330E+00
-1.4266E-01 -3.3276E-01 -2.9123E-01 7.8079E-02 2.7578E-02 7.2578E-01 9.7612E-02 -2.7122E+01 1.3330E+00 2.3514E-02

KC, THE TRANSIENT CONTROL GAIN MATRIX

5.6790E-01 1.3259E+00 1.1615E+00 -3.1278E-01 -1.1034E-01 -2.8906E+00 -3.8983E-01 1.0826E+02 -5.0021E+00 -8.0904E-02
-6.6741E-01 -1.5795E+00 -1.4033E+00 3.9913E-01 1.4091E-01 3.5298E+00 5.2151E-01 -1.3575E+02 5.9094E+00 9.7612E-02

TIME = 0.30000E+01

RICCATI SOLUTION MATRIX

2.9062E+00 3.5794E+00 2.0443E+00 -5.3487E-01 -1.8417E-01 -5.0959E+00 -6.6743E-01 1.8430E+02 -8.9063E+00 -1.4266E-01
3.5794E+00 7.6634E+00 4.7730E+00 -1.4447E+00 -4.4992E-01 -1.1878E+01 -1.5796E+00 4.3760E+02 -2.0674E+01 -3.3276E-01
2.0443E+00 4.7730E+00 4.1811E+00 -1.1259E+00 -3.9720E-01 -1.0406E+01 -1.4033E+00 3.8972E+02 -1.8006E+01 -2.9123E-01
-5.3487E-01 -1.4447E+00 -1.1259E+00 1.0368E+00 1.3492E-01 2.6975E+00 3.9913E-01 -1.1216E+02 4.7259E+00 7.8079E-02
-1.8417E-01 -4.4992E-01 -3.9720E-01 1.3492E-01 1.4378E-01 9.5317E-01 1.4091E-01 -3.8870E+01 1.6783E+00 2.7578E-02
-5.0959E+00 -1.1878E+01 -1.0406E+01 2.6975E+00 9.5317E-01 3.0526E+01 3.5298E+00 -1.0218E+03 4.3201E+01 7.2579E-01
-6.6743E-01 -1.5796E+00 -1.4033E+00 3.9913E-01 1.4091E-01 3.5298E+00 5.2152E-01 -1.3575E+02 5.9095E+00 9.7614E-02
1.8430E+02 4.3760E+02 3.8972E+02 -1.1216E+02 -3.8870E+01 -1.0218E+03 -1.3575E+02 5.6723E+04 -8.5940E+02 -2.7123E+01
-8.9063E+00 -2.0674E+01 -1.8006E+01 4.7259E+00 1.6783E+00 4.3201E+01 5.9095E+00 -8.5940E+02 1.2534E+02 1.3331E+00
-1.4266E-01 -3.3276E-01 -2.9123E-01 7.8079E-02 2.7578E-02 7.2579E-01 9.7613E-02 -2.7123E+01 1.3331E+00 2.3515E-02

ORIGINAL PAGE IS
OF POOR QUALITY

KC, THE TRANSIENT CONTROL GAIN MATRIX

5.6791E-01	1.3259E+00	1.1615E+00	-3.1278E-01	-1.1034E-01	-2.8907E+00	-3.8984E-01	1.0827E+02	-5.0022E+00	-8.0905E-02
-6.6743E-01	-1.5796E+00	-1.4033E+00	3.9913E-01	1.4091E-01	3.5298E+00	5.2152E-01	-1.3575E+02	5.9095E+00	9.7614E-02

TIME = 0.28000E+01

RICCATI SOLUTION MATRIX

2.9062E+00	3.5795E+00	2.0444E+00	-5.3489E-01	-1.8418E-01	-5.0961E+00	-6.6745E-01	1.8431E+02	-8.9065E+00	-1.4266E-01
3.5795E+00	7.6635E+00	4.7731E+00	-1.4447E+00	-4.4992E-01	-1.1878E+01	-1.5796E+00	4.3760E+02	-2.0675E+01	-3.3277E-01
2.0444E+00	4.7731E+00	4.1812E+00	-1.1259E+00	-3.9720E-01	-1.0406E+01	-1.4033E+00	3.8973E+02	-1.8007E+01	-2.9124E-01
-5.3489E-01	-1.4447E+00	-1.1259E+00	1.0368E+00	1.3492E-01	2.6975E+00	3.9913E-01	-1.1216E+02	4.7260E+00	7.8080E-02
-1.8418E-01	-4.4992E-01	-3.9720E-01	1.3492E-01	1.4378E-01	9.5318E-01	1.4091E-01	-3.8870E+01	1.6783E+00	2.7578E-02
-5.0961E+00	-1.1878E+01	-1.0406E+01	2.6975E+00	9.5318E-01	3.0527E+01	3.5299E+00	-1.0218E+03	4.3202E+01	7.2580E-01
-6.6745E-01	-1.5796E+00	-1.4033E+00	3.9913E-01	1.4091E-01	3.5299E+00	5.2152E-01	-1.3575E+02	5.9096E+00	9.7615E-02
1.8431E+02	4.3760E+02	3.8973E+02	-1.1216E+02	-3.8870E+01	-1.0218E+03	-1.3575E+02	5.6724E+04	-8.5942E+02	-2.7123E+01
-8.9065E+00	-2.0675E+01	-1.8007E+01	4.7260E+00	1.6783E+00	4.3202E+01	5.9096E+00	-8.5942E+02	1.2534E+02	1.3331E+00
-1.4266E-01	-3.3277E-01	-2.9124E-01	7.8079E-02	2.7578E-02	7.2580E-01	9.7615E-02	-2.7123E+01	1.3331E+00	2.3515E-02

KC, THE TRANSIENT CONTROL GAIN MATRIX

5.6793E-01	1.3260E+00	1.1615E+00	-3.1278E-01	-1.1034E-01	-2.8907E+00	-3.8984E-01	1.0827E+02	-5.0023E+00	-8.0906E-02
-6.6745E-01	-1.5796E+00	-1.4033E+00	3.9913E-01	1.4091E-01	3.5299E+00	5.2152E-01	-1.3575E+02	5.9096E+00	9.7615E-02

TIME = 0.26000E+01

RICCATI SOLUTION MATRIX

2.9063E+00	3.5796E+00	2.0444E+00	-5.3491E-01	-1.8418E-01	-5.0962E+00	-6.6747E-01	1.8431E+02	-8.9068E+00	-1.4267E-01
3.5796E+00	7.6636E+00	4.7731E+00	-1.4448E+00	-4.4993E-01	-1.1878E+01	-1.5796E+00	4.3761E+02	-2.0675E+01	-3.3277E-01
2.0444E+00	4.7731E+00	4.1812E+00	-1.1259E+00	-3.9721E-01	-1.0406E+01	-1.4033E+00	3.8973E+02	-1.8007E+01	-2.9124E-01
-5.3491E-01	-1.4448E+00	-1.1259E+00	1.0368E+00	1.3492E-01	2.6975E+00	3.9914E-01	-1.1217E+02	4.7260E+00	7.8080E-02
-1.8418E-01	-4.4993E-01	-3.9721E-01	1.3492E-01	1.4378E-01	9.5319E-01	1.4091E-01	-3.8871E+01	1.6783E+00	2.7579E-02
-5.0962E+00	-1.1878E+01	-1.0406E+01	2.6975E+00	9.5319E-01	3.0527E+01	3.5299E+00	-1.0218E+03	4.3202E+01	7.2580E-01
-6.6747E-01	-1.5796E+00	-1.4033E+00	3.9914E-01	1.4091E-01	3.5299E+00	5.2153E-01	-1.3575E+02	5.9097E+00	9.7616E-02
1.8431E+02	4.3761E+02	3.8973E+02	-1.1217E+02	-3.8871E+01	-1.0218E+03	-1.3575E+02	5.6724E+04	-8.5944E+02	-2.7123E+01
-8.9068E+00	-2.0675E+01	-1.8007E+01	4.7260E+00	1.6783E+00	4.3202E+01	5.9097E+00	-8.5944E+02	1.2534E+02	1.3331E+00
-1.4267E-01	-3.3277E-01	-2.9124E-01	7.8080E-02	2.7579E-02	7.2580E-01	9.7616E-02	-2.7123E+01	1.3331E+00	2.3515E-02

KC, THE TRANSIENT CONTROL GAIN MATRIX

5.6795E-01	1.3260E+00	1.1615E+00	-3.1278E-01	-1.1034E-01	-2.8907E+00	-3.8985E-01	1.0827E+02	-5.0023E+00	-8.0907E-02
-6.6747E-01	-1.5796E+00	-1.4033E+00	3.9914E-01	1.4091E-01	3.5299E+00	5.2153E-01	-1.3575E+02	5.9097E+00	9.7616E-02

TIME = 0.24000E+01

RICCATI SOLUTION MATRIX

2.9063E+00	3.5796E+00	2.0445E+00	-5.3493E-01	-1.8419E-01	-5.0963E+00	-6.6748E-01	1.8432E+02	-8.9070E+00	-1.4267E-01
3.5796E+00	7.6637E+00	4.7732E+00	-1.4448E+00	-4.4994E-01	-1.1878E+01	-1.5796E+00	4.3762E+02	-2.0675E+01	-3.3278E-01
2.0445E+00	4.7732E+00	4.1813E+00	-1.1259E+00	-3.9721E-01	-1.0406E+01	-1.4033E+00	3.8974E+02	-1.8007E+01	-2.9124E-01
-5.3493E-01	-1.4448E+00	-1.1259E+00	1.0368E+00	1.3492E-01	2.6975E+00	3.9914E-01	-1.1217E+02	4.7261E+00	7.8081E-02
-1.8419E-01	-4.4994E-01	-3.9721E-01	1.3492E-01	1.4378E-01	9.5320E-01	1.4091E-01	-3.8871E+01	1.6783E+00	2.7579E-02
-5.0963E+00	-1.1878E+01	-1.0406E+01	2.6975E+00	9.5320E-01	3.0527E+01	3.5300E+00	-1.0218E+03	4.3203E+01	7.2581E-01
-6.6748E-01	-1.5796E+00	-1.4033E+00	3.9914E-01	1.4091E-01	3.5300E+00	5.2153E-01	-1.3575E+02	5.9097E+00	9.7617E-02
1.8432E+02	4.3762E+02	3.8974E+02	-1.1217E+02	-3.8871E+01	-1.0218E+03	-1.3575E+02	5.6725E+04	-8.5946E+02	-2.7124E+01

-8.9070E+00 -2.0675E+01 -1.8007E+01 4.7261E+00 1.6783E+00 4.3203E+01 5.9097E+00 -8.5546E+02 1.2534E+02 1.3331E+00
 -1.4267E-01 -3.3278E-01 -2.9124E-01 7.8081E-02 2.7579E-02 7.2581E-01 9.7617E-02 -2.7124E+01 1.3331E+00 2.3515E-02

KC, THE TRANSIENT CONTROL GAIN MATRIX

5.6796E-01 1.3260E+00 1.1616E+00 -3.1279E-01 -1.1035E-01 -2.8908E+00 -3.8985E-01 1.0827E+02 -5.0024E+00 -8.0908E-02
 -6.6748E-01 -1.5796E+00 -1.4033E+00 3.9914E-01 1.4091E-01 3.5300E+00 5.2153E-01 -1.3575E+02 5.9097E+00 9.7617E-02

TIME = 0.22000E+01

RICCATI SOLUTION MATRIX

2.9064E+00 3.5797E+00 2.0445E+00 -5.3495E-01 -1.8419E-01 -5.0964E+00 -6.6750E-01 1.8432E+02 -8.9071E+00 -1.4267E-01
 3.5797E+00 7.6638E+00 4.7733E+00 -1.4448E+00 -4.4994E-01 -1.1879E+01 -1.5796E+00 4.3762E+02 -2.0675E+01 -3.3278E-01
 2.0445E+00 4.7733E+00 4.1813E+00 -1.1260E+00 -3.9722E-01 -1.0406E+01 -1.4034E+00 3.8974E+02 -1.8007E+01 -2.9125E-01
 -5.3495E-01 -1.4448E+00 -1.1260E+00 1.0368E+00 1.3492E-01 2.6976E+00 3.9915E-01 -1.1217E+02 4.7261E+00 7.8082E-02
 -1.8419E-01 -4.4994E-01 -3.9722E-01 1.3492E-01 1.4378E-01 9.5321E-01 1.4092E-01 -3.8872E+01 1.6783E+00 2.7579E-02
 -5.0964E+00 -1.1879E+01 -1.0406E+01 2.6976E+00 9.5321E-01 3.0527E+01 3.5300E+00 -1.0218E+03 4.3203E+01 7.2582E-01
 -6.6750E-01 -1.5796E+00 -1.4034E+00 3.9915E-01 1.4092E-01 3.5300E+00 5.2154E-01 -1.3575E+02 5.9098E+00 9.7618E-02
 1.8432E+02 4.3762E+02 3.8974E+02 -1.1217E+02 -3.8872E+01 -1.0218E+03 -1.3575E+02 5.6725E+04 -8.5947E+02 -2.7124E+01
 -8.9071E+00 -2.0675E+01 -1.8007E+01 4.7261E+00 1.6783E+00 4.3203E+01 5.9098E+00 -8.5947E+02 1.2534E+02 1.3331E+00
 -1.4267E-01 -3.3278E-01 -2.9125E-01 7.8082E-02 2.7579E-02 7.2582E-01 9.7618E-02 -2.7124E+01 1.3331E+00 2.3516E-02

KC, THE TRANSIENT CONTROL GAIN MATRIX

5.6797E-01 1.3260E+00 1.1616E+00 -3.1279E-01 -1.1035E-01 -2.8908E+00 -3.8985E-01 1.0827E+02 -5.0024E+00 -8.0908E-02
 -6.6750E-01 -1.5796E+00 -1.4034E+00 3.9915E-01 1.4092E-01 3.5300E+00 5.2154E-01 -1.3575E+02 5.9098E+00 9.7618E-02

TIME = 0.20000E+01

RICCATI SOLUTION MATRIX

2.9064E+00 3.5798E+00 2.0446E+00 -5.3496E-01 -1.8419E-01 -5.0965E+00 -6.6751E-01 1.8433E+02 -8.9073E+00 -1.4268E-01
 3.5798E+00 7.6638E+00 4.7733E+00 -1.4448E+00 -4.4995E-01 -1.1879E+01 -1.5797E+00 4.3763E+02 -2.0676E+01 -3.3279E-01
 2.0446E+00 4.7733E+00 4.1813E+00 -1.1260E+00 -3.9722E-01 -1.0406E+01 -1.4034E+00 3.8974E+02 -1.8007E+01 -2.9125E-01
 -5.3496E-01 -1.4448E+00 -1.1260E+00 1.0368E+00 1.3492E-01 2.6976E+00 3.9915E-01 -1.1217E+02 4.7262E+00 7.8083E-02
 -1.8419E-01 -4.4995E-01 -3.9722E-01 1.3492E-01 1.4378E-01 9.5322E-01 1.4092E-01 -3.8872E+01 1.6784E+00 2.7580E-02
 -5.0965E+00 -1.1879E+01 -1.0406E+01 2.6976E+00 9.5322E-01 3.0528E+01 3.5300E+00 -1.0219E+03 4.3203E+01 7.2583E-01
 -6.6751E-01 -1.5797E+00 -1.4034E+00 3.9915E-01 1.4092E-01 3.5300E+00 5.2154E-01 -1.3575E+02 5.9098E+00 9.7619E-02
 1.8433E+02 4.3763E+02 3.8974E+02 -1.1217E+02 -3.8872E+01 -1.0219E+03 -1.3575E+02 5.6725E+04 -8.5949E+02 -2.7124E+01
 -8.9073E+00 -2.0676E+01 -1.8007E+01 4.7262E+00 1.6784E+00 4.3203E+01 5.9098E+00 -8.5949E+02 1.2534E+02 1.3331E+00
 -1.4268E-01 -3.3279E-01 -2.9125E-01 7.8083E-02 2.7580E-02 7.2583E-01 9.7619E-02 -2.7124E+01 1.3331E+00 2.3516E-02

KC, THE TRANSIENT CONTROL GAIN MATRIX

5.6798E-01 1.3260E+00 1.1616E+00 -3.1279E-01 -1.1035E-01 -2.8908E+00 -3.8986E-01 1.0827E+02 -5.0025E+00 -8.0909E-02
 -6.6751E-01 -1.5797E+00 -1.4034E+00 3.9915E-01 1.4092E-01 3.5300E+00 5.2154E-01 -1.3575E+02 5.9098E+00 9.7619E-02

TIME = 0.18000E+01

RICCATI SOLUTION MATRIX

2.9064E+00 3.5798E+00 2.0446E+00 -5.3498E-01 -1.8420E-01 -5.0966E+00 -6.6752E-01 1.8433E+02 -8.9074E+00 -1.4268E-01
 3.5798E+00 7.6639E+00 4.7734E+00 -1.4448E+00 -4.4995E-01 -1.1879E+01 -1.5797E+00 4.3763E+02 -2.0676E+01 -3.3279E-01
 2.0446E+00 4.7734E+00 4.1814E+00 -1.1260E+00 -3.9722E-01 -1.0406E+01 -1.4034E+00 3.8975E+02 -1.8008E+01 -2.9125E-01
 -5.3497E-01 -1.4448E+00 -1.1260E+00 1.0368E+00 1.3492E-01 2.6976E+00 3.9915E-01 -1.1217E+02 4.7262E+00 7.8084E-02
 -1.8420E-01 -4.4995E-01 -3.9722E-01 1.3492E-01 1.4378E-01 9.5323E-01 1.4092E-01 -3.8872E+01 1.6784E+00 2.7580E-02

2.0447E+00	4.7735E+00	4.1814E+00	-1.1260E+00	-3.9723E-01	-1.0406E+01	-1.4034E+00	3.8975E+02	-1.8008E+01	-2.9126E-01
-5.3500E-01	-1.4449E+00	-1.1260E+00	1.0368E+00	1.3493E-01	2.6977E+00	3.9917E-01	-1.1217E+02	4.7264E+00	7.8086E-02
-1.8420E-01	-4.4996E-01	-3.9723E-01	1.3492E-01	1.4378E-01	9.5325E-01	1.4092E-01	-3.8873E+01	1.6784E+00	2.7580E-02
-5.0967E+00	-1.1879E+01	-1.0406E+01	2.6977E+00	9.5325E-01	3.0528E+01	3.5301E+00	-1.0219E+03	4.3205E+01	7.2585E-01
-6.6754E-01	-1.5797E+00	-1.4034E+00	3.9917E-01	1.4092E-01	3.5301E+00	5.2155E-01	-1.3576E+02	5.9100E+00	9.7621E-02
1.8433E+02	4.3764E+02	3.8975E+02	-1.1217E+02	-3.8873E+01	-1.0219E+03	-1.3576E+02	5.6726E+04	-8.5953E+02	-2.7125E+01
-8.9077E+00	-2.0676E+01	-1.8008E+01	4.7264E+00	1.6784E+00	4.3205E+01	5.9100E+00	-8.5953E+02	1.2534E+02	1.3332E+00
-1.4268E-01	-3.3280E-01	-2.9126E-01	7.8086E-02	2.7580E-02	7.2584E-01	9.7621E-02	-2.7125E+01	1.3332E+00	2.3516E-02

KC, THE TRANSIENT CONTROL GAIN MATRIX

5.6801E-01	1.3261E+00	1.1616E+00	-3.1281E-01	-1.1035E-01	-2.8909E+00	-3.8987E-01	1.0827E+02	-5.0026E+00	-8.0911E-02
-6.6754E-01	-1.5797E+00	-1.4034E+00	3.9917E-01	1.4092E-01	3.5301E+00	5.2155E-01	-1.3576E+02	5.9100E+00	9.7621E-02

TIME = 0.10000E+01

RICCATI SOLUTION MATRIX

2.9065E+00	3.5799E+00	2.0447E+00	-5.3501E-01	-1.8420E-01	-5.0968E+00	-6.6755E-01	1.8434E+02	-8.9078E+00	-1.4268E-01
3.5799E+00	7.6641E+00	4.7735E+00	-1.4449E+00	-4.4997E-01	-1.1879E+01	-1.5797E+00	4.3765E+02	-2.0677E+01	-3.3280E-01
2.0447E+00	4.7735E+00	4.1815E+00	-1.1260E+00	-3.9723E-01	-1.0406E+01	-1.4034E+00	3.8976E+02	-1.8008E+01	-2.9126E-01
-5.3501E-01	-1.4449E+00	-1.1260E+00	1.0368E+00	1.3493E-01	2.6978E+00	3.9917E-01	-1.1217E+02	4.7264E+00	7.8087E-02
-1.8420E-01	-4.4997E-01	-3.9723E-01	1.3493E-01	1.4378E-01	9.5325E-01	1.4092E-01	-3.8873E+01	1.6784E+00	2.7581E-02
-5.0968E+00	-1.1879E+01	-1.0406E+01	2.6978E+00	9.5325E-01	3.0529E+01	3.5301E+00	-1.0219E+03	4.3205E+01	7.2585E-01
-6.6755E-01	-1.5797E+00	-1.4034E+00	3.9917E-01	1.4092E-01	3.5301E+00	5.2156E-01	-1.3576E+02	5.9100E+00	9.7622E-02
1.8434E+02	4.3765E+02	3.8976E+02	-1.1217E+02	-3.8873E+01	-1.0219E+03	-1.3576E+02	5.6727E+04	-8.5954E+02	-2.7125E+01
-8.9077E+00	-2.0677E+01	-1.8008E+01	4.7264E+00	1.6784E+00	4.3205E+01	5.9100E+00	-8.5954E+02	1.2534E+02	1.3332E+00
-1.4268E-01	-3.3280E-01	-2.9126E-01	7.8087E-02	2.7581E-02	7.2585E-01	9.7622E-02	-2.7125E+01	1.3332E+00	2.3516E-02

KC, THE TRANSIENT CONTROL GAIN MATRIX

5.6801E-01	1.3261E+00	1.1616E+00	-3.1281E-01	-1.1035E-01	-2.8909E+00	-3.8987E-01	1.0827E+02	-5.0026E+00	-8.0912E-02
-6.6755E-01	-1.5797E+00	-1.4034E+00	3.9917E-01	1.4092E-01	3.5301E+00	5.2156E-01	-1.3576E+02	5.9100E+00	9.7622E-02

TIME = 0.80000E+00

RICCATI SOLUTION MATRIX

2.9065E+00	3.5799E+00	2.0447E+00	-5.3502E-01	-1.8421E-01	-5.0968E+00	-6.6755E-01	1.8434E+02	-8.9078E+00	-1.4269E-01
3.5799E+00	7.6642E+00	4.7735E+00	-1.4449E+00	-4.4997E-01	-1.1879E+01	-1.5797E+00	4.3765E+02	-2.0677E+01	-3.3280E-01
2.0447E+00	4.7735E+00	4.1815E+00	-1.1260E+00	-3.9724E-01	-1.0407E+01	-1.4034E+00	3.8976E+02	-1.8008E+01	-2.9126E-01
-5.3502E-01	-1.4449E+00	-1.1260E+00	1.0368E+00	1.3493E-01	2.6978E+00	3.9917E-01	-1.1217E+02	4.7265E+00	7.8088E-02
-1.8421E-01	-4.4997E-01	-3.9724E-01	1.3493E-01	1.4378E-01	9.5326E-01	1.4092E-01	-3.8873E+01	1.6784E+00	2.7581E-02
-5.0968E+00	-1.1879E+01	-1.0407E+01	2.6978E+00	9.5326E-01	3.0529E+01	3.5302E+00	-1.0219E+03	4.3205E+01	7.2585E-01
-6.6755E-01	-1.5797E+00	-1.4034E+00	3.9917E-01	1.4092E-01	3.5302E+00	5.2156E-01	-1.3576E+02	5.9101E+00	9.7622E-02
1.8434E+02	4.3765E+02	3.8976E+02	-1.1217E+02	-3.8873E+01	-1.0219E+03	-1.3576E+02	5.6727E+04	-8.5955E+02	-2.7125E+01
-8.9078E+00	-2.0677E+01	-1.8008E+01	4.7265E+00	1.6784E+00	4.3205E+01	5.9100E+00	-8.5955E+02	1.2534E+02	1.3332E+00
-1.4269E-01	-3.3280E-01	-2.9126E-01	7.8087E-02	2.7581E-02	7.2585E-01	9.7622E-02	-2.7125E+01	1.3332E+00	2.3517E-02

KC, THE TRANSIENT CONTROL GAIN MATRIX

5.6801E-01	1.3261E+00	1.1616E+00	-3.1281E-01	-1.1035E-01	-2.8909E+00	-3.8987E-01	1.0827E+02	-5.0026E+00	-8.0912E-02
-6.6755E-01	-1.5797E+00	-1.4034E+00	3.9917E-01	1.4092E-01	3.5302E+00	5.2156E-01	-1.3576E+02	5.9101E+00	9.7622E-02

TIME = 0.60000E+00

2.0447E+00	4.7735E+00	4.1814E+00	-1.1260E+00	-3.9723E-01	-1.0406E+01	-1.4034E+00	3.8975E+02	-1.8008E+01	-2.9126E-01
-5.3500E-01	-1.4449E+00	-1.1260E+00	1.0368E+00	1.3493E-01	2.6977E+00	3.9917E-01	-1.1217E+02	4.7264E+00	7.8086E-02
-1.8420E-01	-4.4996E-01	-3.9723E-01	1.3492E-01	1.4378E-01	9.5325E-01	1.4092E-01	-3.8873E+01	1.6784E+00	2.7580E-02
-5.0967E+00	-1.1879E+01	-1.0406E+01	2.6977E+00	9.5325E-01	3.0528E+01	3.5301E+00	-1.0219E+03	4.3205E+01	7.2585E-01
-6.6754E-01	-1.5797E+00	-1.4034E+00	3.9917E-01	1.4092E-01	3.5301E+00	5.2155E-01	-1.3576E+02	5.9100E+00	9.7621E-02
1.8433E+02	4.3764E+02	3.8975E+02	-1.1217E+02	-3.8873E+01	-1.0219E+03	-1.3576E+02	5.6726E+04	-8.5953E+02	-2.7125E+01
-8.9077E+00	-2.0676E+01	-1.8008E+01	4.7264E+00	1.6784E+00	4.3205E+01	5.9100E+00	-8.5953E+02	1.2534E+02	1.3332E+00
-1.4268E-01	-3.3280E-01	-2.9126E-01	7.8086E-02	2.7580E-02	7.2584E-01	9.7621E-02	-2.7125E+01	1.3332E+00	2.3516E-02

KC, THE TRANSIENT CONTROL GAIN MATRIX

5.6801E-01	1.3261E+00	1.1616E+00	-3.1281E-01	-1.1035E-01	-2.8909E+00	-3.8987E-01	1.0827E+02	-5.0026E+00	-8.0911E-02
-6.6754E-01	-1.5797E+00	-1.4034E+00	3.9917E-01	1.4092E-01	3.5301E+00	5.2155E-01	-1.3576E+02	5.9100E+00	9.7621E-02

TIME = 0.10000E+01

RICCATI SOLUTION MATRIX

2.9065E+00	3.5799E+00	2.0447E+00	-5.3501E-01	-1.8420E-01	-5.0968E+00	-6.6755E-01	1.8434E+02	-8.9078E+00	-1.4268E-01
3.5799E+00	7.6641E+00	4.7735E+00	-1.4449E+00	-4.4997E-01	-1.1879E+01	-1.5797E+00	4.3765E+02	-2.0677E+01	-3.3280E-01
2.0447E+00	4.7735E+00	4.1815E+00	-1.1260E+00	-3.9723E-01	-1.0406E+01	-1.4034E+00	3.8976E+02	-1.8008E+01	-2.9126E-01
-5.3501E-01	-1.4449E+00	-1.1260E+00	1.0368E+00	1.3493E-01	2.6978E+00	3.9917E-01	-1.1217E+02	4.7264E+00	7.8087E-02
-1.8420E-01	-4.4997E-01	-3.9723E-01	1.3493E-01	1.4378E-01	9.5325E-01	1.4092E-01	-3.8873E+01	1.6784E+00	2.7581E-02
-5.0968E+00	-1.1879E+01	-1.0406E+01	2.6978E+00	9.5325E-01	3.0529E+01	3.5301E+00	-1.0219E+03	4.3205E+01	7.2585E-01
-6.6755E-01	-1.5797E+00	-1.4034E+00	3.9917E-01	1.4092E-01	3.5301E+00	5.2156E-01	-1.3576E+02	5.9100E+00	9.7622E-02
1.8434E+02	4.3765E+02	3.8976E+02	-1.1217E+02	-3.8873E+01	-1.0219E+03	-1.3576E+02	5.6727E+04	-8.5954E+02	-2.7125E+01
-8.9077E+00	-2.0677E+01	-1.8008E+01	4.7264E+00	1.6784E+00	4.3205E+01	5.9100E+00	-8.5954E+02	1.2534E+02	1.3332E+00
-1.4268E-01	-3.3280E-01	-2.9126E-01	7.8087E-02	2.7581E-02	7.2585E-01	9.7622E-02	-2.7125E+01	1.3332E+00	2.3516E-02

KC, THE TRANSIENT CONTROL GAIN MATRIX

5.6801E-01	1.3261E+00	1.1616E+00	-3.1281E-01	-1.1035E-01	-2.8909E+00	-3.8987E-01	1.0827E+02	-5.0026E+00	-8.0912E-02
-6.6755E-01	-1.5797E+00	-1.4034E+00	3.9917E-01	1.4092E-01	3.5301E+00	5.2156E-01	-1.3576E+02	5.9100E+00	9.7622E-02

TIME = 0.80000E+00

RICCATI SOLUTION MATRIX

2.9065E+00	3.5799E+00	2.0447E+00	-5.3502E-01	-1.8421E-01	-5.0968E+00	-6.6755E-01	1.8434E+02	-8.9078E+00	-1.4269E-01
3.5799E+00	7.6642E+00	4.7735E+00	-1.4449E+00	-4.4997E-01	-1.1879E+01	-1.5797E+00	4.3765E+02	-2.0677E+01	-3.3280E-01
2.0447E+00	4.7735E+00	4.1815E+00	-1.1260E+00	-3.9724E-01	-1.0407E+01	-1.4034E+00	3.8976E+02	-1.8008E+01	-2.9126E-01
-5.3502E-01	-1.4449E+00	-1.1260E+00	1.0368E+00	1.3493E-01	2.6978E+00	3.9917E-01	-1.1217E+02	4.7265E+00	7.8088E-02
-1.8421E-01	-4.4997E-01	-3.9724E-01	1.3493E-01	1.4378E-01	9.5326E-01	1.4092E-01	-3.8873E+01	1.6784E+00	2.7581E-02
-5.0968E+00	-1.1879E+01	-1.0407E+01	2.6978E+00	9.5326E-01	3.0529E+01	3.5302E+00	-1.0219E+03	4.3205E+01	7.2585E-01
-6.6755E-01	-1.5797E+00	-1.4034E+00	3.9917E-01	1.4092E-01	3.5302E+00	5.2156E-01	-1.3576E+02	5.9101E+00	9.7622E-02
1.8434E+02	4.3765E+02	3.8976E+02	-1.1217E+02	-3.8873E+01	-1.0219E+03	-1.3576E+02	5.6727E+04	-8.5955E+02	-2.7125E+01
-8.9078E+00	-2.0677E+01	-1.8008E+01	4.7265E+00	1.6784E+00	4.3205E+01	5.9100E+00	-8.5955E+02	1.2534E+02	1.3332E+00
-1.4269E-01	-3.3280E-01	-2.9126E-01	7.8087E-02	2.7581E-02	7.2585E-01	9.7622E-02	-2.7125E+01	1.3332E+00	2.3517E-02

KC, THE TRANSIENT CONTROL GAIN MATRIX

5.6801E-01	1.3261E+00	1.1616E+00	-3.1281E-01	-1.1035E-01	-2.8909E+00	-3.8987E-01	1.0827E+02	-5.0026E+00	-8.0912E-02
-6.6755E-01	-1.5797E+00	-1.4034E+00	3.9917E-01	1.4092E-01	3.5302E+00	5.2156E-01	-1.3576E+02	5.9101E+00	9.7622E-02

TIME = 0.60000E+00

RICCATI SOLUTION MATRIX

2.9065E+00	3.5800E+00	2.0447E+00	-5.3502E-01	-1.8421E-01	-5.0968E+00	-6.6755E-01	1.8434E+02	-8.9078E+00	-1.4269E-01
3.5799E+00	7.6642E+00	4.7736E+00	-1.4449E+00	-4.4997E-01	-1.1879E+01	-1.5797E+00	4.3765E+02	-2.0677E+01	-3.3280E-01
2.0447E+00	4.7736E+00	4.1815E+00	-1.1260E+00	-3.9724E-01	-1.0407E+01	-1.4034E+00	3.8976E+02	-1.8008E+01	-2.9126E-01
-5.3502E-01	-1.4449E+00	-1.1260E+00	1.0368E+00	1.3493E-01	2.6978E+00	3.9917E-01	-1.1218E+02	4.7265E+00	7.8088E-02
-1.8421E-01	-4.4997E-01	-3.9724E-01	1.3493E-01	1.4378E-01	9.5326E-01	1.4092E-01	-3.8874E+01	1.6784E+00	2.7581E-02
-5.0968E+00	-1.1879E+01	-1.0407E+01	2.6978E+00	9.5326E-01	3.0529E+01	3.5302E+00	-1.0219E+03	4.3205E+01	7.2585E-01
-6.6755E-01	-1.5797E+00	-1.4034E+00	3.9917E-01	1.4092E-01	3.5302E+00	5.2156E-01	-1.3576E+02	5.9101E+00	9.7622E-02
1.8434E+02	4.3765E+02	3.8976E+02	-1.1218E+02	-3.8874E+01	-1.0219E+03	-1.3576E+02	5.6727E+04	-8.5955E+02	-2.7125E+01
-8.9078E+00	-2.0677E+01	-1.8008E+01	4.7265E+00	1.6784E+00	4.3205E+01	5.9101E+00	-8.5955E+02	1.2534E+02	1.3332E+00
-1.4269E-01	-3.3280E-01	-2.9126E-01	7.8088E-02	2.7581E-02	7.2585E-01	9.7622E-02	-2.7125E+01	1.3332E+00	2.3517E-02

KC, THE TRANSIENT CONTROL GAIN MATRIX

5.6802E-01	1.3261E+00	1.1616E+00	-3.1281E-01	-1.1035E-01	-2.8909E+00	-3.8987E-01	1.0828E+02	-5.0027E+00	-8.0912E-02
-6.6755E-01	-1.5797E+00	-1.4034E+00	3.9917E-01	1.4092E-01	3.5302E+00	5.2156E-01	-1.3576E+02	5.9101E+00	9.7622E-02

TIME = 0.40000E+00

RICCATI SOLUTION MATRIX

2.9065E+00	3.5800E+00	2.0447E+00	-5.3503E-01	-1.8421E-01	-5.0968E+00	-6.6756E-01	1.8434E+02	-8.9079E+00	-1.4269E-01
3.5800E+00	7.6642E+00	4.7736E+00	-1.4449E+00	-4.4997E-01	-1.1879E+01	-1.5798E+00	4.3765E+02	-2.0677E+01	-3.3281E-01
2.0447E+00	4.7736E+00	4.1815E+00	-1.1260E+00	-3.9724E-01	-1.0407E+01	-1.4034E+00	3.8976E+02	-1.8008E+01	-2.9126E-01
-5.3503E-01	-1.4449E+00	-1.1260E+00	1.0368E+00	1.3493E-01	2.6978E+00	3.9918E-01	-1.1218E+02	4.7265E+00	7.8088E-02
-1.8421E-01	-4.4997E-01	-3.9724E-01	1.3493E-01	1.4378E-01	9.5326E-01	1.4092E-01	-3.8874E+01	1.6784E+00	2.7581E-02
-5.0968E+00	-1.1879E+01	-1.0407E+01	2.6978E+00	9.5327E-01	3.0529E+01	3.5302E+00	-1.0219E+03	4.3205E+01	7.2586E-01
-6.6756E-01	-1.5798E+00	-1.4034E+00	3.9918E-01	1.4092E-01	3.5302E+00	5.2156E-01	-1.3576E+02	5.9101E+00	9.7623E-02
1.8434E+02	4.3765E+02	3.8976E+02	-1.1218E+02	-3.8874E+01	-1.0219E+03	-1.3576E+02	5.6727E+04	-8.5956E+02	-2.7125E+01
-8.9079E+00	-2.0677E+01	-1.8008E+01	4.7265E+00	1.6784E+00	4.3205E+01	5.9101E+00	-8.5956E+02	1.2534E+02	1.3332E+00
-1.4269E-01	-3.3280E-01	-2.9126E-01	7.8088E-02	2.7581E-02	7.2586E-01	9.7623E-02	-2.7125E+01	1.3332E+00	2.3517E-02

KC, THE TRANSIENT CONTROL GAIN MATRIX

5.6802E-01	1.3261E+00	1.1616E+00	-3.1282E-01	-1.1035E-01	-2.8909E+00	-3.8987E-01	1.0828E+02	-5.0027E+00	-8.0913E-02
-6.6756E-01	-1.5798E+00	-1.4034E+00	3.9918E-01	1.4092E-01	3.5302E+00	5.2156E-01	-1.3576E+02	5.9101E+00	9.7623E-02

TIME = 0.20000E+00

RICCATI SOLUTION MATRIX

2.9065E+00	3.5800E+00	2.0447E+00	-5.3503E-01	-1.8421E-01	-5.0969E+00	-6.6756E-01	1.8434E+02	-8.9079E+00	-1.4269E-01
3.5800E+00	7.6642E+00	4.7736E+00	-1.4449E+00	-4.4998E-01	-1.1879E+01	-1.5798E+00	4.3765E+02	-2.0677E+01	-3.3281E-01
2.0447E+00	4.7736E+00	4.1815E+00	-1.1261E+00	-3.9724E-01	-1.0407E+01	-1.4034E+00	3.8976E+02	-1.8008E+01	-2.9126E-01
-5.3503E-01	-1.4449E+00	-1.1261E+00	1.0368E+00	1.3493E-01	2.6978E+00	3.9918E-01	-1.1218E+02	4.7265E+00	7.8089E-02
-1.8421E-01	-4.4998E-01	-3.9724E-01	1.3493E-01	1.4378E-01	9.5327E-01	1.4092E-01	-3.8874E+01	1.6784E+00	2.7581E-02
-5.0969E+00	-1.1879E+01	-1.0407E+01	2.6978E+00	9.5327E-01	3.0529E+01	3.5302E+00	-1.0219E+03	4.3205E+01	7.2586E-01
-6.6756E-01	-1.5798E+00	-1.4034E+00	3.9918E-01	1.4092E-01	3.5302E+00	5.2156E-01	-1.3576E+02	5.9101E+00	9.7623E-02
1.8434E+02	4.3765E+02	3.8976E+02	-1.1218E+02	-3.8874E+01	-1.0219E+03	-1.3576E+02	5.6727E+04	-8.5956E+02	-2.7125E+01
-8.9079E+00	-2.0677E+01	-1.8008E+01	4.7265E+00	1.6784E+00	4.3205E+01	5.9101E+00	-8.5956E+02	1.2534E+02	1.3332E+00
-1.4269E-01	-3.3281E-01	-2.9126E-01	7.8089E-02	2.7581E-02	7.2586E-01	9.7623E-02	-2.7125E+01	1.3332E+00	2.3517E-02

KC, THE TRANSIENT CONTROL GAIN MATRIX

5.6802E-01	1.3261E+00	1.1616E+00	-3.1282E-01	-1.1035E-01	-2.8910E+00	-3.8987E-01	1.0828E+02	-5.0027E+00	-8.0913E-02
-6.6756E-01	-1.5798E+00	-1.4034E+00	3.9918E-01	1.4092E-01	3.5302E+00	5.2156E-01	-1.3576E+02	5.9101E+00	9.7623E-02

-6.6735E-01 -1.5795E+00 -1.4033E+00 3.9914E-01 1.4091E-01 3.5297E+00 5.2150E-01 -1.3574E+02 5.9093E+00 9.7610E-02

TIME = 0.34000E+01

RICCATI SOLUTION MATRIX

2.9060E+00	3.5792E+00	2.0442E+00	-5.3484E-01	-1.8415E-01	-5.0956E+00	-6.6738E-01	1.8427E+02	-8.9056E+00	-1.4265E-01
3.5792E+00	7.6632E+00	4.7728E+00	-1.4447E+00	-4.4990E-01	-1.1878E+01	-1.5795E+00	4.3758E+02	-2.0674E+01	-3.3275E-01
2.0442E+00	4.7728E+00	4.1810E+00	-1.1259E+00	-3.9719E-01	-1.0405E+01	-1.4033E+00	3.8971E+02	-1.8006E+01	-2.9123E-01
-5.3484E-01	-1.4447E+00	-1.1259E+00	1.0369E+00	1.3492E-01	2.6975E+00	3.9913E-01	-1.1216E+02	4.7259E+00	7.8079E-02
-1.8415E-01	-4.4990E-01	-3.9719E-01	1.3492E-01	1.4378E-01	9.5314E-01	1.4091E-01	-3.8869E+01	1.6782E+00	2.7577E-02
-5.0956E+00	-1.1878E+01	-1.0405E+01	2.6975E+00	9.5314E-01	3.0526E+01	3.5298E+00	-1.0218E+03	4.3200E+01	7.2577E-01
-6.6738E-01	-1.5795E+00	-1.4033E+00	3.9913E-01	1.4091E-01	3.5298E+00	5.2151E-01	-1.3574E+02	5.9094E+00	9.7611E-02
1.8427E+02	4.3758E+02	3.8971E+02	-1.1216E+02	-3.8869E+01	-1.0218E+03	-1.3574E+02	5.6723E+04	-8.5936E+02	-2.7122E+01
-8.9056E+00	-2.0674E+01	-1.8006E+01	4.7259E+00	1.6782E+00	4.3200E+01	5.9094E+00	-8.5936E+02	1.2533E+02	1.3330E+00
-1.4265E-01	-3.3275E-01	-2.9123E-01	7.8079E-02	2.7577E-02	7.2577E-01	9.7611E-02	-2.7122E+01	1.3330E+00	2.3514E-02

KC, THE TRANSIENT CONTROL GAIN MATRIX

5.6787E-01	1.3259E+00	1.1615E+00	-3.1278E-01	-1.1034E-01	-2.8906E+00	-3.8983E-01	1.0826E+02	-5.0021E+00	-8.0903E-02
-6.6738E-01	-1.5795E+00	-1.4033E+00	3.9913E-01	1.4091E-01	3.5298E+00	5.2151E-01	-1.3574E+02	5.9094E+00	9.7611E-02

TIME = 0.32000E+01

RICCATI SOLUTION MATRIX

2.9061E+00	3.5793E+00	2.0443E+00	-5.3485E-01	-1.8416E-01	-5.0957E+00	-6.6741E-01	1.8430E+02	-8.9060E+00	-1.4266E-01
3.5793E+00	7.6633E+00	4.7729E+00	-1.4447E+00	-4.4991E-01	-1.1878E+01	-1.5795E+00	4.3759E+02	-2.0674E+01	-3.3276E-01
2.0443E+00	4.7729E+00	4.1811E+00	-1.1259E+00	-3.9719E-01	-1.0405E+01	-1.4033E+00	3.8972E+02	-1.8006E+01	-2.9123E-01
-5.3485E-01	-1.4447E+00	-1.1259E+00	1.0368E+00	1.3492E-01	2.6975E+00	3.9913E-01	-1.1216E+02	4.7259E+00	7.8079E-02
-1.8416E-01	-4.4991E-01	-3.9719E-01	1.3492E-01	1.4378E-01	9.5315E-01	1.4091E-01	-3.8870E+01	1.6782E+00	2.7578E-02
-5.0957E+00	-1.1878E+01	-1.0405E+01	2.6975E+00	9.5315E-01	3.0526E+01	3.5298E+00	-1.0218E+03	4.3201E+01	7.2578E-01
-6.6741E-01	-1.5795E+00	-1.4033E+00	3.9913E-01	1.4091E-01	3.5298E+00	5.2151E-01	-1.3575E+02	5.9094E+00	9.7612E-02
1.8430E+02	4.3759E+02	3.8972E+02	-1.1216E+02	-3.8870E+01	-1.0218E+03	-1.3575E+02	5.6723E+04	-8.5938E+02	-2.7122E+01
-8.9060E+00	-2.0674E+01	-1.8006E+01	4.7259E+00	1.6782E+00	4.3200E+01	5.9094E+00	-8.5938E+02	1.2533E+02	1.3330E+00
-1.4266E-01	-3.3276E-01	-2.9123E-01	7.8079E-02	2.7578E-02	7.2578E-01	9.7612E-02	-2.7122E+01	1.3330E+00	2.3514E-02

KC, THE TRANSIENT CONTROL GAIN MATRIX

5.6790E-01	1.3259E+00	1.1615E+00	-3.1278E-01	-1.1034E-01	-2.8906E+00	-3.8983E-01	1.0826E+02	-5.0021E+00	-8.0904E-02
-6.6741E-01	-1.5795E+00	-1.4033E+00	3.9913E-01	1.4091E-01	3.5298E+00	5.2151E-01	-1.3575E+02	5.9094E+00	9.7612E-02

TIME = 0.30000E+01

RICCATI SOLUTION MATRIX

2.9062E+00	3.5794E+00	2.0443E+00	-5.3487E-01	-1.8417E-01	-5.0959E+00	-6.6743E-01	1.8430E+02	-8.9063E+00	-1.4266E-01
3.5794E+00	7.6634E+00	4.7730E+00	-1.4447E+00	-4.4992E-01	-1.1878E+01	-1.5796E+00	4.3760E+02	-2.0674E+01	-3.3276E-01
2.0443E+00	4.7730E+00	4.1811E+00	-1.1259E+00	-3.9720E-01	-1.0406E+01	-1.4033E+00	3.8972E+02	-1.8006E+01	-2.9123E-01
-5.3487E-01	-1.4447E+00	-1.1259E+00	1.0368E+00	1.3492E-01	2.6975E+00	3.9913E-01	-1.1216E+02	4.7259E+00	7.8079E-02
-1.8417E-01	-4.4991E-01	-3.9720E-01	1.3492E-01	1.4378E-01	9.5317E-01	1.4091E-01	-3.8870E+01	1.6783E+00	2.7578E-02
-5.0959E+00	-1.1878E+01	-1.0406E+01	2.6975E+00	9.5317E-01	3.0526E+01	3.5298E+00	-1.0218E+03	4.3201E+01	7.2579E-01
-6.6743E-01	-1.5796E+00	-1.4033E+00	3.9913E-01	1.4091E-01	3.5298E+00	5.2152E-01	-1.3575E+02	5.9095E+00	9.7614E-02
1.8430E+02	4.3760E+02	3.8972E+02	-1.1216E+02	-3.8870E+01	-1.0218E+03	-1.3575E+02	5.6723E+04	-8.5940E+02	-2.7123E+01
-8.9063E+00	-2.0674E+01	-1.8006E+01	4.7259E+00	1.6783E+00	4.3201E+01	5.9095E+00	-8.5940E+02	1.2534E+02	1.3331E+00
-1.4266E-01	-3.3276E-01	-2.9123E-01	7.8079E-02	2.7578E-02	7.2579E-01	9.7613E-02	-2.7123E+01	1.3331E+00	2.3515E-02

 COVARIANCE MATRICES

UU, CONTROL COVARIANCE MATRIX
 6.4973E+00 -7.6532E+00
 -7.6532E+00 9.0185E+00

XX, STATE COVARIANCE MATRIX

5.6968E+01	-5.0000E-02	-8.7344E+00	4.9172E-01	-5.7717E-01	5.8709E-02	-1.2795E-01	1.1403E-04	-1.9179E-04	-1.9258E-03
-5.0000E-02	8.7344E+00	-5.0000E-02	4.1140E+00	7.3644E-01	1.2795E-01	-2.6336E-03	1.9175E-04	1.9258E-03	-8.7040E-03
-8.7344E+00	-5.0000E-02	8.3488E+00	1.5482E+00	1.1164E+00	2.6336E-03	4.8224E-01	-1.5257E-03	8.7025E-03	2.6818E+00
4.9172E-01	4.1140E+00	1.5482E+00	2.8766E+00	6.8533E-01	8.4732E-02	3.8430E-02	1.0679E-04	1.9647E-03	-7.2983E-03
-5.7717E-01	7.3644E-01	1.1164E+00	6.8533E-01	2.6707E-01	1.8432E-02	4.5859E-02	-2.1045E-05	1.7520E-03	-5.0305E-04
5.8709E-02	1.2795E-01	2.6336E-03	8.4732E-02	1.8432E-02	1.3548E-02	-5.0000E-02	1.8298E-05	1.1045E-04	-1.0914E-03
-1.2795E-01	-2.6336E-03	4.8224E-01	3.8430E-02	4.5859E-02	-5.0000E-02	4.0241E-01	-1.1046E-04	1.0914E-03	1.3919E-02
1.1403E-04	1.9175E-04	-1.9257E-03	1.0679E-04	-2.1045E-05	1.8298E-05	-1.1046E-04	3.0917E-05	-5.0000E-04	-1.3742E-02
-1.9179E-04	1.9258E-03	8.7025E-03	1.9647E-03	1.7520E-03	1.1045E-04	1.0914E-03	-5.0000E-04	1.3742E-02	-5.0000E-04
-1.9258E-03	-8.7040E-03	2.6818E+00	-7.2983E-03	-5.0305E-04	-1.0914E-03	1.3919E-02	-1.3742E-02	-5.0000E-04	1.9114E+01

YY, OUTPUT COVARIANCE MATRIX

1.2545E+01	2.6985E+01	8.9500E+01
2.6985E+01	2.2195E+04	6.3889E+02
8.9500E+01	6.3889E+02	2.3885E+03

YYEST, ESTIMATED OUTPUT COVARIANCE MATRIX

6.0843E+00	3.8534E+00	1.9257E+01
3.8534E+00	1.2939E+04	1.5448E+02
1.9257E+01	1.5447E+02	1.0810E+03

ZZ, MEASUREMENT COVARIANCE MATRIX

1.2545E+01	2.6985E+01	8.9500E+01	6.8547E+00
2.6985E+01	2.2195E+04	6.3889E+02	-8.8262E+00
8.9500E+01	6.3889E+02	2.3885E+03	3.4900E+01
6.8547E+00	-8.8262E+00	3.4900E+01	7.9914E+00

ZZEST, ESTIMATED MEASUREMENT COVARIANCE MATRIX

6.0843E+00	3.8534E+00	1.9257E+01	4.0402E+00
3.8534E+00	1.2939E+04	1.5448E+02	-7.6674E+00
1.9257E+01	1.5447E+02	1.0810E+03	1.1154E+01
4.0403E+00	-7.6675E+00	1.1154E+01	3.9359E+00

APPENDIX C

TIME AND STORAGE REQUIREMENTS

The computer used for the sample LSOCE problem was the IBM 7090-7094 with DCS (Direct Couple System). This computer has 77000_8 (32000_{10}) core storage locations with capabilities of overlay. For the sample problem, no overlay was used. The 10th-order sample problem described in appendix B used 67000_8 storage and took 1.75 minutes to run.

The following table shows various subroutines and approximate time (in sec) per call for the sample problem:

Subroutine	Time, sec/call
ESTMAT	10.0
CONTRL	10.0
RICSS	9.0
CONDI	2.5
REDU	.8
SCALE	1.7
EIGQR	.9
ORDER	.02
EGVCTR	6.5
PRMUTE	.02
COVM	4.0
LYPNV	3.5
TRICCS	40.0
BDSTM	.001

In addition, problems as large as 41st-order have been run on an IBM 360-67 using TSS (Time Sharing System) with good results. The only change was the use of double precision instead of single precision throughout the program.

REFERENCES

1. Lehtinen, Bruce; Zeller, John R.; and Geysler, Lucille C.: Optimal Control of Supersonic Inlets to Minimize Unstarts. NASA TN D-6408, 1971.
2. Lehtinen, Bruce; and Zeller, John R.: Application of Quadratic Optimization to Supersonic Inlet Control. Automatica, vol. 8, Sept. 1972, pp. 563-574.
3. Bryson, Arthur E., Jr.; and Ho, Yu-Chi: Applied Optimal Control. Blaisdell Pub. Co., 1969, pp. 414-417.
4. Kalman, R. E.; and Englar, T. S.: A User's Manual for the Automatic Synthesis Program (Program C). NASA CR-475, 1966.
5. Freested, W. C.; Webber, R. F.; and Bass, R. W.: The "GASP" Computer Program - an Integrated Tool for Optimal Control and Filter Design. Proceedings of Ninth Joint Automatic Control Conference, Univ. Mich., Ann Arbor, Mich., June 26-28, 1968, pp. 198-202.
6. Vaughan, David R.: A Negative Exponential Solution for the Linear Optimal Regulator Problem. Proceedings of Ninth Joint Automatic Control Conference, Univ. Mich., Ann Arbor, Mich., June 26-28, 1968, pp. 717-725.
7. Kleinman, David L.: On an Iterative Technique for Riccati Equation Computations. IEEE Trans. on Automatic Control, vol. AC-13, no. 1, Feb. 1968, pp. 114-115.
8. Greenberg, Stuart G.; and Bard, Yonathan: A Comparison of Computational Methods for Solving the Algebraic Matrix Riccati Equation. Proceedings of IEEE Conference on Decision and Control, Miami Beach, Fla., Dec. 15-17, 1971, pp. 214-215.
9. Fath, A. F.: Computational Aspects of the Linear Optimal Regulator Problem. IEEE Trans. on Automatic Control, vol. AC-14, no. 5, Oct. 1969, pp. 547-550.
10. MacFarlane, A. G. J.: An Eigenvector Solution to the Optimal Linear Regulator Problem. J. Electronics and Control, vol. 14, no. 6, June 1963, pp. 643-654.
11. O'Donnell, J. J.: Asymptotic Solution of the Matrix Riccati Equation of Optimal Control. Proceedings of Fourth Annual Allerton Conference on Circuit and System Theory, Univ. Illinois, Oct. 5-7, 1966, pp. 577-586.
12. Potter, James E.: Matrix Quadratic Solutions. SIAM J. Appl. Math., vol. 14, May 1966, pp. 496-501.
13. Chen, C. F.; and Shieh, L. S.: A Note on Expanding $PA + A^T P = -Q$. IEEE Trans. on Automatic Control, vol. AC-13, no. 1, Feb. 1968, pp. 122-123.
14. Smith, R. A.: Matrix Equation $XA + BX = C$. SIAM J. Appl. Math., vol. 16, Jan. 1968, pp. 198-201.

15. Harary, F.: A Graph Theoretic Method for the Complete Reduction of a Matrix with a View Toward Finding Its Eigenvalues. *J. Math. Phys.*, vol. 38, no. 2, July 1959, pp. 104-111.
16. Francis, J. G. F.: The QR Transformation. A Unitary Analogue to the LR Transformation - Part I. *Computer J.*, vol. 4, no. 3, 1962, pp. 265-271.
17. Francis, J. G. F.: The QR Transformation. A Unitary Analogue to the LR Transformation - Part II. *Computer J.*, vol. 4, no. 3, 1962, pp. 322-345.
18. Wilkinson, J. H.: *The Algebraic Eigenvalue Problem*. Clarendon Press, 1965.

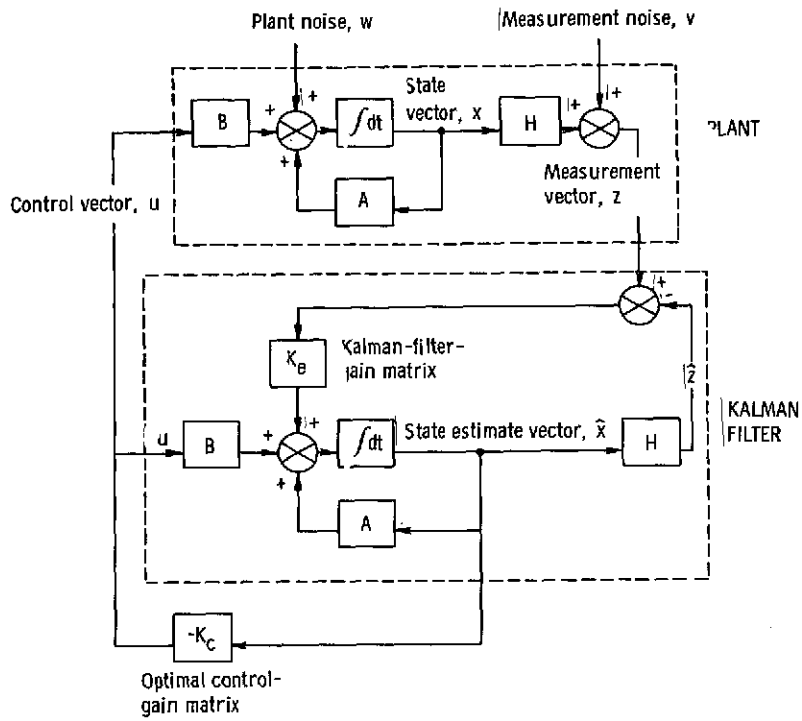

Figure 1. - Plant, Kalman filter, state-estimate feedback combination.

ORIGINAL PAGE IS
OF POOR QUALITY

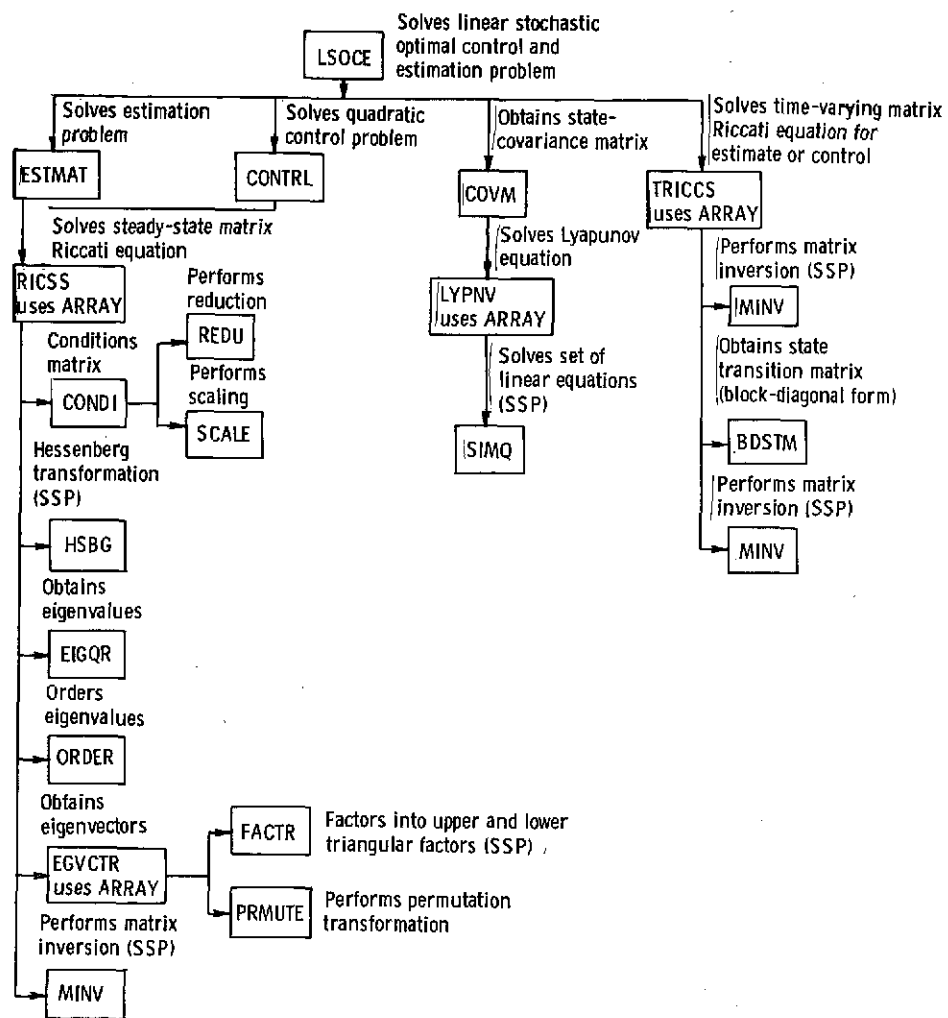

Figure 2. - Flow chart for linear stochastic optimal control and estimation (LSOCE) problem solution.

ORIGINAL PAGE IS
OF POOR QUALITY