

NASA TECHNICAL
REPORT



NASA TR R-443

NASA TR R-443

MAGNETIC TORQUE ON A ROTATING
SUPERCONDUCTING SPHERE

Louis B. Holdeman

*George C. Marshall Space Flight Center
Marshall Space Flight Center, Ala. 35812*



NATIONAL AERONAUTICS AND SPACE ADMINISTRATION • WASHINGTON, D. C. • MAY 1975

1. REPORT NO. NASA TR R-443		2. GOVERNMENT ACCESSION NO.		3. RECIPIENT'S CATALOG NO.	
4. TITLE AND SUBTITLE Magnetic Torque on a Rotating Superconducting Sphere				5. REPORT DATE MAY 1975	
				6. PERFORMING ORGANIZATION CODE	
7. AUTHOR(S) Louis B. Holdeman				8. PERFORMING ORGANIZATION REPORT # M138	
9. PERFORMING ORGANIZATION NAME AND ADDRESS George C. Marshall Space Flight Center Marshall Space Flight Center, Alabama 35812				10. WORK UNIT NO.	
				11. CONTRACT OR GRANT NO.	
12. SPONSORING AGENCY NAME AND ADDRESS National Aeronautics and Space Administration Washington, D.C. 20546				13. TYPE OF REPORT & PERIOD COVERED Technical Report	
				14. SPONSORING AGENCY CODE	
15. SUPPLEMENTARY NOTES Prepared by Space Sciences Laboratory, Science and Engineering					
16. ABSTRACT Using the London theory of superconductivity, the torque on a superconducting sphere rotating in a uniform applied magnetic field is calculated exactly. The London theory is combined with classical electrodynamics for a calculation of the direct effect of excess charge on a rotating superconducting sphere. Classical electrodynamics with the assumption of a perfect Meissner effect is used to calculate the torque on a superconducting sphere rotating in an arbitrary magnetic induction; this "macroscopic" approach yields results which are correct to first order in λ/R , where λ is the London penetration depth and R is the sphere radius. Using the same approach, the torque due to a current loop encircling the rotating sphere is calculated.					
17. KEY WORDS				18. DISTRIBUTION STATEMENT Unclassified-Unlimited Cat. 76	
19. SECURITY CLASSIF. (of this report) Unclassified		20. SECURITY CLASSIF. (of this page) Unclassified		21. NO. OF PAGES 50	22. PRICE \$3.75

ACKNOWLEDGMENTS

The author would like to thank Dr. J. T. Holdeman, Jr., of the Oak Ridge National Laboratory for helpful suggestions and illuminating discussions; his critical review of the manuscript is gratefully acknowledged. A critical review of the manuscript by Dr. E. W. Urban of Space Sciences Laboratory, Marshall Space Flight Center, was also greatly appreciated. The author is indebted to the Associateship Office of the National Academy of Sciences/National Research Council and to NASA, George C. Marshall Space Flight Center, for their support.

TABLE OF CONTENTS

	Page
I. SUMMARY	1
II. INTRODUCTION	1
III. CALCULATIONS BASED ON THE LONDON THEORY	2
A. Introduction to the London Theory	2
B. Rotating Superconducting Sphere	4
C. Torque on a Rotating Superconducting Sphere in a Uniform Applied Field	11
D. Rotating Superconducting Spherical Shell	16
E. Effect of Excess Charge on the Rotor	18
IV. CALCULATIONS USING CLASSICAL ELECTRODYNAMICS WITH THE ASSUMPTION OF A PERFECT MEISSNER EFFECT	22
A. Introduction to a Macroscopic Approach	22
B. Torque on a Rotating Superconducting Sphere in an Arbitrary Magnetic Field	29
C. The Infinite Superconducting Plane	34
D. Torque due to a Current in the Readout Loop	34
E. Torque due to a Flat Region in the Superconducting Shield	37
F. Discussion	40
V. REFERENCES	42

LIST OF ILLUSTRATIONS

Figure	Title	Page
1.	Coordinate system for a stationary superconducting sphere in a uniform applied field ($\vec{B} \rightarrow \hat{z}B_0$ as $ \vec{r} \rightarrow \infty$)	8
2.	Coordinate system for a rotating superconducting sphere with no field applied	10
3.	A current loop around the rotor	35
4.	A proposed shield design	37
5.	Image method for calculating torque due to the flat spot in the point dipole/infinite superconducting plane approximation	38

DEFINITION OF SYMBOLS

Symbol	Definition
λ	London penetration depth; the characteristic distance over which currents and magnetic fields vary within a superconductor. In the London theory, $\lambda^2 = m^* c^2 / 4\pi n_s e^{*2}$
β	$\beta = 1/\lambda$; a symbol introduced for mathematical convenience
ξ	coherence length; the characteristic distance over which superconducting properties vary within a superconductor
n_s	density (number per unit volume) of superconducting electrons
e	electronic charge (note that $e < 0$)
e^*	charge on a superelectron (Cooper pair); $e^* = 2e$
m	mass of the electron
m^*	mass of a superelectron; $m^* = 2m$
c	speed of light
σ	electrical conductivity
μ	magnetic permeability
\AA	Angstrom unit; a unit of length equal to 10^{-10} meter
ω	angular frequency of rotation
$\vec{\omega}$	a vector directed along the spin axis having magnitude ω
$\hat{x}, \hat{y}, \hat{z}$	unit vectors in a Cartesian coordinate system (coordinates x, y, z)
$\hat{r}, \hat{\theta}, \hat{\phi}$	unit vectors in a spherical coordinate system (coordinates r, θ, ϕ)
\vec{M}	London Moment; the magnetic field outside a rotating superconducting sphere is the same as that due to a point dipole located at the center of the sphere having a magnetic moment $\vec{M} = (m^*c/e^*)[1 - (3\cosh\beta R/\beta R \sinh\beta R) + (3/\beta^2 R^2)] R^3 \vec{\omega} \approx (m^*c/e^*)R^3 \vec{\omega}$

DEFINITION OF SYMBOLS (Concluded)

Symbol	Definition
$P_\ell(x)$	Legendre polynomials; functions orthogonal on the interval $[-1,1]$
$Y_{\ell m}(\theta, \phi)$	spherical harmonics; functions orthonormal on the surface of the unit sphere $[0 \leq \phi \leq 2\pi]$, $[0 \leq \theta \leq \pi]$
ρ	electric charge density
\vec{B}, \vec{H}	magnetic induction, magnetic field intensity, respectively; related by the constitutive relation $\vec{B} = \mu \vec{H}$
$\vec{e}, \vec{h}, \vec{j}$	local values of the electric field, magnetic field, and current density, respectively.
\vec{N}	torque
Ω	angle between the gyro spin axis and the z-axis of the coordinate system

MAGNETIC TORQUE ON A ROTATING SUPERCONDUCTING SPHERE

I. SUMMARY

The London theory is reviewed in Section IIIA, and a theorem extremely useful for calculating torque on a rotating superconducting sphere is proved in Section IIIB. The torque on a rotating superconducting sphere due to a uniform applied field is then calculated exactly in Section IIIC. The rotating superconducting shell is considered in Section IIID and an estimate of the minimum thickness of the superconducting coating for the rotor is obtained. The direct effect of excess charge on the rotor is calculated in Section IIIE.

A macroscopic approach is introduced in Section IVA and is shown to give results for fields, currents, and torques which are correct to order λ/R ; the torque in an arbitrary magnetic field is then calculated in Section IVB. It is pointed out in Section IVC that problems for which the only superconductor present is an infinite superconducting plane can be solved by image methods; in Section IVD this fact is used to calculate the torque on the rotor due to a current flowing in the readout loop. In Section IVE the torque due to a flat spot in the superconducting magnetic shield surrounding the rotor is discussed, and the torque is calculated for the limiting case of a very large flat spot. The results of the calculations are discussed in Section IVF.

II. INTRODUCTION

The scientific goal of the Stanford gyroscope relativity experiment is a test of general relativity through measurement of relativistic precessions of Earth-orbiting gyroscopes [1]. The concepts and ideas for implementation of the experiment have been described in an earlier document [2].

Fundamental design requirements for the experiment are:

1. Development of a spin-axis readout with sufficient stability and sensitivity to measure the small relativistic precessions.
2. Reduction of all nonrelativistic torques to less than 2×10^{-8} N m to achieve a design goal of less than 1 ms of arc per year residual error.

Since an asymmetry of some sort is necessary for readout, requirement (2) adds the constraint that no significant torque be introduced through the asymmetric feature added for this purpose.

The proposed rotor is a fused quartz ball coated with a thin layer of superconducting niobium. The asymmetry for readout is to be the magnetic moment generated by a rotating superconductor along its instantaneous spin axis (London Moment). Precession will be measured by measuring changes in magnetic flux through a superconducting loop encompassing the rotor.

This report presents results of the author's calculation of certain torques coupled to the rotor through its London Moment. A calculation of the direct effect of excess charge on the rotor is also included.

III. CALCULATIONS BASED ON THE LONDON THEORY

A. Introduction to the London Theory

There are two fundamental lengths associated with superconductivity. The characteristic distance over which currents and magnetic fields vary within a superconductor is called the penetration depth, $\lambda(T)$. In the superconducting state, the velocities of two electrons are correlated if the distance between them is less than a certain range ξ . This length, $\xi(T)$, is the characteristic distance over which superconducting properties [for example, the pair potential $\Delta(\vec{r})$] can change and is called the coherence length of the superconductor. It should be emphasized that both λ and ξ are temperature and material dependent.

In 1934, F. and H. London introduced a theory of electrodynamics for superconductors in order to explain the Meissner effect [3]. This theory has since been shown to follow from the condition of minimum free energy (in the limit of weak fields and currents) provided the criterion $\lambda \gg \xi$ is satisfied [4]. It has further been shown [4] that the microscopic (quantum mechanical) theory of superconductivity reduces to the Landau-Ginzburg theory for temperatures near the transition temperature T_c , and the Landau-Ginzburg theory in turn reduces to the London theory for $\lambda \gg \xi$. The London theory permits a complete phenomenological description of superconductivity which is in accord with the principles of thermodynamics and classical electrodynamics.

The London theory is applicable to the calculation of magnetic torques on the gyro: The transition metals generally have large penetration depths ($\lambda \sim 1000 \text{ \AA}$) and small coherence lengths ($\xi \sim 100 \text{ \AA}$) at $T = 0$; niobium is in this class¹. Superconducting shields around the gyro will ensure that the weak field condition is met.

1. Actually, for bulk pure niobium, $\lambda(0) \sim \xi(0) \sim 400 \text{ \AA}$ [5-7]. However, niobium films inevitably have trace impurities which increase $\lambda(0)$ to $\sim 1000 \text{ \AA}$ [6,8], while the shortened mean free path decreases $\xi(0)$ to $\sim 100 \text{ \AA}$ [9].

The London theory assumes Maxwell's equations² to be valid inside a superconductor:

$$\text{I. } \text{curl } \vec{h} = \frac{4\pi}{c} \vec{j} + \frac{1}{c} \frac{\partial \vec{e}}{\partial t} \quad ,$$

$$\text{II. } \text{curl } \vec{e} = -\frac{1}{c} \frac{\partial \vec{h}}{\partial t} \quad ,$$

$$\text{III. } \text{div } \vec{h} = 0 \quad ,$$

$$\text{IV. } \text{div } \vec{e} = 4\pi\rho \quad .$$

Here \vec{j} is the total current density, ρ is the density of electric charge, and \vec{e} and \vec{h} are, respectively, the intensities of electric and magnetic fields³. The relationship between field intensities and the supercurrent density \vec{j}_s is postulated to be:

$$\text{V. } \text{curl} (\lambda^2 \vec{j}_s) = -\frac{c}{4\pi} \vec{h}$$

$$\text{VI. } \frac{\partial}{\partial t} (\lambda^2 \vec{j}_s) = \frac{c^2}{4\pi} \vec{e}$$

The final assumptions are that the total current density is a sum of a supercurrent density \vec{j}_s and a normal current density \vec{j}_n which is connected to the electric field through Ohm's law. Thus,

$$\text{VII. } \vec{j} = \vec{j}_s + \vec{j}_n \quad ,$$

$$\text{VIII. } \vec{j}_n = \sigma \vec{e} \quad .$$

2. The cgs Gaussian system of units will be used for calculations in this memorandum; key results will be expressed in the SI system of units.

3. As in Lorenz's electronic theory, lower case symbols are used to denote local values of internal fields.

These equations can be combined to give

$$\frac{c^2}{\lambda^2} \rho + 4\pi\sigma \frac{\partial \rho}{\partial t} + \frac{\partial^2 \rho}{\partial t^2} = 0$$

and

$$c^2 (\text{curl curl } \vec{h} + \frac{1}{\lambda^2} \vec{h}) + 4\pi\sigma \frac{\partial \vec{h}}{\partial t} + \frac{\partial^2 \vec{h}}{\partial t^2} = 0$$

with equations for \vec{j} and \vec{e} identical to the one for \vec{h} . For quasi-stationary conditions (that is, for frequencies ω satisfying the inequality $\omega \ll c^2/4\pi\sigma\lambda^2 \approx 10^{12} \text{ s}^{-1}$), $\text{div } \vec{e} = 4\pi\rho \approx 0$. The equation for \vec{h} reduces to

$$\text{curl curl } \vec{h} + \frac{1}{\lambda^2} \vec{h} = 0$$

with identical equations for \vec{j} and \vec{e} .

To complete the theory, boundary conditions must be given for all surfaces of discontinuity where different bodies border each other and where the constants characteristic of the material change discontinuously. The boundary conditions are that h_{\parallel} , e_{\parallel} , and h_{\perp}, j_{\perp} must be continuous; h_{\perp} is continuous because the permeability μ has been taken as unity. Finally, $(\lambda^2 j_s)_{\parallel}$ must be continuous at the boundary between two different superconductors.

This brief review of the London theory was included to make this memorandum self-contained; a fuller presentation with sample calculations is given in the excellent monograph by F. London [3].

B. Rotating Superconducting Sphere

For the case of a rotating superconductor, it is assumed that equations (V) and (VI) for the supercurrent are still valid. Using the relations $\lambda^2 = m^*c^2/4\pi n_s e^{*2}$ and $\vec{j}_s = e^* n_s \vec{v}_s$, these equations can be rewritten in terms of the velocity field \vec{v}_s of the superelectrons:

$$\text{curl } \vec{v}_s = -(e^*/m^*c) \vec{h} \quad ,$$

$$\frac{\partial \vec{v}_s}{\partial t} = (e^*/m^*) \vec{e} \quad ,$$

where $e^* = 2e$ and $m^* = 2m$ are the charge and mass, respectively, of a superelectron (Cooper pair). The charge density ρ and the total current density \vec{j} are

$$\rho = e^*(n_s - n_{s0}) \quad ,$$

$$\vec{j} = e^*(n_s \vec{v}_s - n_{s0} \vec{v}_0) \quad ,$$

where n_s is the density of superelectrons in the rotating superconductor, n_{s0} is the density in the same superconductor when stationary, and \vec{v}_0 is the local state of motion of the body.

Consider now the rotating superconducting sphere. To balance the centrifugal force on the electrons, the internal electric field must be

$$\vec{e} = \frac{m\omega^2}{e} (\vec{x} + \vec{y})$$

Note that $\rho = (1/4\pi)\text{div } \vec{e} = (m\omega^2/2\pi e) = (m^*\omega^2/2\pi e^*)$, so that

$$\frac{n_s - n_{s0}}{n_{s0}} = \frac{m^*\omega^2}{2\pi n_{s0}e^*} = \frac{2\lambda^2}{c^2} \omega^2 \sim 10^{-31} \omega^2$$

Thus $(n_s - n_{s0})/n_{s0}$ is much less than 1 even for very large ω , and to an excellent approximation

$$\vec{j} = e^*n_{s0}(\vec{v}_s - \vec{v}_0)$$

Then

$$\text{curl } \vec{j} = e^* n_{s0} (\text{curl } \vec{v}_s - \text{curl } \vec{v}_0) = e^* n_{s0} (-e^*/m^*c) \vec{h} - e^* n_{s0} (2\vec{\omega})$$

Neglecting the displacement current in the Maxwell equation (I) and operating through with the curl, one has (using the above):

$$\lambda^2 \text{curl curl } \vec{h} + \vec{h} = -\frac{2m^*c}{e^*} \vec{\omega}$$

Also,

$$\text{curl curl } \vec{j} = -e^* n_{s0} (e^*/m^*c) \text{curl } \vec{h} = -(4\pi n_{s0} e^{*2}/m^*c^2) \vec{j}$$

so that

$$\lambda^2 \text{curl curl } \vec{j} + \vec{j} = 0$$

Since boundary conditions are the same for the rotating superconducting sphere as for the stationary sphere, one can now prove a simple theorem which will be extremely useful for torque calculations:

Theorem:

Let \vec{h}_0 and \vec{j}_0 be the solutions to London's equations for a stationary superconducting sphere in an arbitrary field \vec{B} , and let \vec{h}_L and \vec{j}_L be solutions for the rotating sphere in zero applied field. Then the solutions to the London equations for the sphere rotating in the field \vec{B} are $\vec{h} = \vec{h}_0 + \vec{h}_L$ and $\vec{j} = \vec{j}_0 + \vec{j}_L$.

Proof:

$$\lambda^2 \text{curl curl } \vec{j} = \lambda^2 \text{curl curl } \vec{j}_0 + \lambda^2 \text{curl curl } \vec{j}_L = -\vec{j}_0 - \vec{j}_L = -\vec{j}$$

$$\begin{aligned} \lambda^2 \text{curl curl } \vec{h} &= \lambda^2 \text{curl curl } \vec{h}_0 + \lambda^2 \text{curl curl } \vec{h}_L = -\vec{h}_0 - \left(\vec{h}_L + \frac{2m^*c}{e^*} \vec{\omega} \right) \\ &= -\vec{h} - \frac{2m^*c}{e^*} \vec{\omega} \quad \blacksquare \end{aligned}$$

It is clear from symmetry that the theorem also holds in the case of a spherical superconducting shell.

The current and field solutions for the rotating superconducting sphere, and for the stationary sphere in a uniform⁴ applied field, are derived in London's book [3]. For the stationary sphere in a uniform applied magnetic induction \vec{B}_0 , one has (with the z-axis parallel to \vec{B}_0 as in Figure 1):

$$\left. \begin{aligned} h_r^0 &= \left(B_0 + \frac{2M'}{r^3} \right) \cos\theta \\ h_\theta^0 &= \left(-B_0 + \frac{M'}{r^3} \right) \sin\theta \\ h_\phi^0 &= 0 \end{aligned} \right\} r \geq R ,$$

$$\left. \begin{aligned} h_r^0 &= \frac{2A'}{\beta^2 r^3} (\sinh \beta r - \beta r \cosh \beta r) \cos\theta \\ h_\theta^0 &= \frac{A'}{\beta^2 r^3} [(1 + \beta^2 r^2) \sinh \beta r - \beta r \cosh \beta r] \sin\theta \\ h_\phi^0 &= 0 \end{aligned} \right\} r \leq R ,$$

4. Because of the diamagnetism of the superconductor, $\vec{h} \neq \vec{B}_0$ outside the sphere. However, it is required that $\vec{h} \rightarrow \vec{B}_0$ as $|\vec{r}| \rightarrow \infty$.

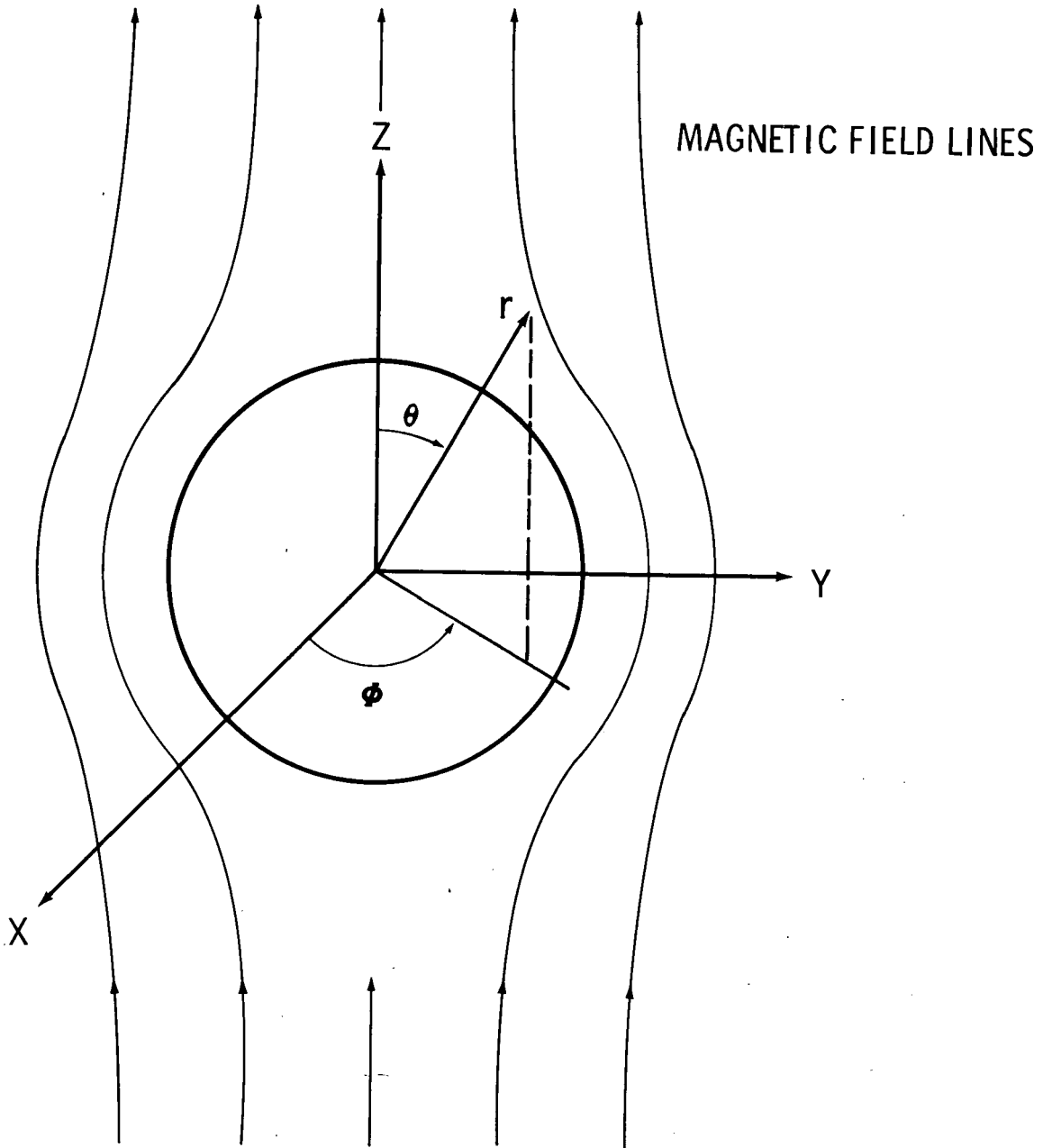

Figure 1. Coordinate system for a stationary superconducting sphere in a uniform applied field ($\vec{B} \rightarrow \hat{z}B_0$ as $|\vec{r}| \rightarrow \infty$).

and

$$\vec{j}_0 = \left[\frac{cA'}{4\pi r^2} (\sinh \beta r - \beta r \cosh \beta r) \sin\theta \right] \hat{\phi} \quad ,$$

where

$$\beta^2 = 1/\lambda^2 = 4\pi n_s e^{*2}/m^*c^2 \quad ,$$

$$M' = -\frac{B_0 R^3}{2} \left(1 - \frac{3 \cosh \beta R}{\beta R \sinh \beta R} + \frac{3}{\beta^2 R^2} \right) \quad ,$$

and

$$A' = -\frac{3B_0}{2} \frac{R}{\sinh \beta R}$$

For the rotating sphere, one has (with the z-axis chosen along $\vec{\omega}$ as in Figure 2):

$$\left. \begin{aligned} h_r^L &= \frac{2M}{r^3} \cos\theta \\ h_\theta^L &= \frac{M}{r^3} \sin\theta \\ h_\phi^L &= 0 \end{aligned} \right\} \quad r \geq R \quad ,$$

$$\left. \begin{aligned} h_r^L &= \frac{m^*c}{e^*} \left[2\omega + \frac{2A}{r^3} (\sinh \beta r - \beta r \cosh \beta r) \right] \cos\theta \\ h_\theta^L &= \frac{m^*c}{e^*} \left\{ -2\omega + \frac{A}{r^3} \left[(1 + \beta^2 r^2) \sinh \beta r - \beta r \cosh \beta r \right] \right\} \sin\theta \\ h_\phi^L &= 0 \end{aligned} \right\} \quad r \leq R \quad ,$$

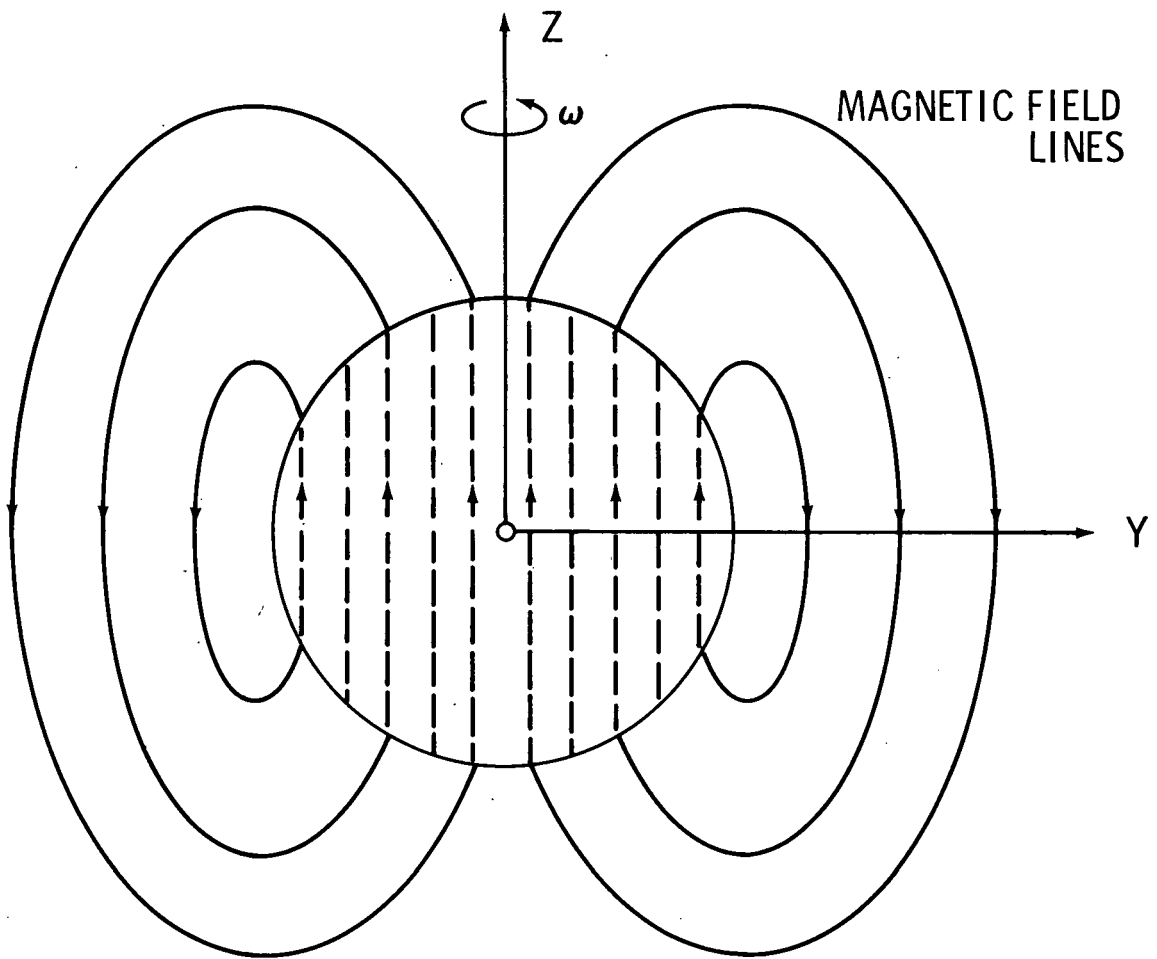

Figure 2. Coordinate system for a rotating superconducting sphere with no field applied. (The X axis of the coordinate system points out of the page in this figure.)

and

$$\vec{j}_L = - \left[\frac{3 n_s e^* \omega R}{\sinh \beta R} \frac{1}{\beta r} \left(\cosh \beta r - \frac{1}{\beta r} \sinh \beta r \right) \sin \theta \right] \cdot \hat{\phi} ,$$

where

$$A = \frac{3 \omega R}{\beta^2 \sinh \beta R}$$

and

$$M = \frac{m^*c}{e^*} \omega R^3 \left(1 - \frac{3 \cosh \beta R}{\beta R \sinh \beta R} + \frac{3}{\beta^2 R^2} \right)$$

(M is called the London Moment.) In both cases the origin of the coordinate system is in the center of the sphere. These solutions will be used in ensuing calculations.

C. Torque on a Rotating Superconducting Sphere in a Uniform Applied Field

Although the rotor will be enclosed in a superconducting shield, the shield will have holes for electrode leads, pump out lines, gas spin-up ports, etc.; magnetic field could possibly enter through these holes. To obtain an estimate of the torque due to leakage field, the torque on a rotating superconducting sphere in a uniform applied field \vec{B}_0 will be calculated. This problem can be solved exactly.

The torque \vec{N} on a current distribution $\vec{j}(\vec{r})$ in a magnetic flux density $\vec{h}(\vec{r})$ is given by [10]:

$$\vec{N} = \frac{1}{c} \int_v d^3r [\vec{r} \times (\vec{j} \times \vec{h})]$$

Appealing to the theorem, one writes $\vec{j} = \vec{j}_0 + \vec{j}_L$ and $\vec{h} = \vec{h}_0 + \vec{h}_L$, where $\vec{j}_0, \vec{j}_L, \vec{h}_0$, and \vec{h}_L are the solutions quoted at the end of the last section. Substituting, one has

$$\begin{aligned} \vec{N} = & \frac{1}{c} \int_v d^3r [\vec{r} \times (\vec{j}_0 \times \vec{h}_0)] + \frac{1}{c} \int_v d^3r [\vec{r} \times (\vec{j}_L \times \vec{h}_L)] \\ & + \frac{1}{c} \int_v d^3r [\vec{r} \times (\vec{j}_0 \times \vec{h}_L)] + \frac{1}{c} \int_v d^3r [\vec{r} \times (\vec{j}_L \times \vec{h}_0)] \end{aligned}$$

It is easy to show by straightforward substitution that the first two integrals are zero, so that

$$\vec{N} = \frac{1}{c} \int_v d^3r [\vec{r} \times (\vec{j}_0 \times \vec{h}_L)] + \frac{1}{c} \int_v d^3r [\vec{r} \times (\vec{j}_L \times \vec{h}_0)] \equiv \vec{N}^{(1)} + \vec{N}^{(2)}$$

In a coordinate system with the z-axis chosen parallel to \vec{B}_0 , \vec{j}_0 has the form (see Section IIIB)

$$\vec{j}_0 = f_0(r) \sin\theta \hat{\phi}$$

and \vec{h}_0 has the form ($r \leq R$)

$$\vec{h}_0 = h_r^0(r, \theta) \hat{r} + h_\theta^0(r, \theta) \hat{\theta} = F_0(r) \cos\theta \hat{r} + G_0(r) \sin\theta \hat{\theta}$$

Similarly, in a coordinate system with the z-axis chosen along $\vec{\omega}$, \vec{j}_L has the form

$$\vec{j}_L = f_L(r) \sin\theta \hat{\phi}$$

and \vec{h}_L has the form

$$\vec{h}_L = h_r^L(r, \theta) \hat{r} + h_\theta^L(r, \theta) \hat{\theta} = F_L(r) \cos\theta \hat{r} + G_L(r) \sin\theta \hat{\theta}$$

Now torque is a pseudovector and, hence, is invariant under coordinate rotations. Therefore, in evaluating the integrals, the orientation of the coordinate system may be chosen for mathematical convenience. In the integral $\vec{N}^{(1)}$, choose \hat{z} parallel to $\vec{\omega}$ with \hat{y} perpendicular to the plane defined by $\vec{\omega}$ and \vec{B}_0 ; in the integral $\vec{N}^{(2)}$, choose \hat{z} parallel to \vec{B}_0 with \hat{y} again perpendicular to the plane defined by $\vec{\omega}$ and \vec{B}_0 . (After calculations are complete, the results must be expressed in the same coordinate system before being added.)

Thus in each integral the field has the form previously indicated, and the current must be rewritten in the new coordinates. If Ω is the angle between $\vec{\omega}$ and \vec{B}_0 , then in either case the transformation represents a rotation through angle Ω about the y-axis: Clockwise ($+\Omega$) for one integral and counterclockwise ($-\Omega$) for the other. In Cartesian coordinates, one has for either integral (since $r = |\vec{r}|$ is invariant under rotation)

$$\begin{aligned} \vec{h} &= \sin\theta \cos\theta \cos\phi [F(r) + G(r)] \hat{x} + \sin\theta \cos\theta \sin\phi [F(r) + G(r)] \hat{y} \\ &+ [\cos^2\theta F(r) - \sin^2\theta G(r)] \hat{z} = \hat{x} h_x + \hat{y} h_y + \hat{z} h_z \end{aligned}$$

and

$$\begin{aligned} \vec{j} &= -f(r) \sin\theta \sin\phi \cos\Omega \hat{x} + f(r) [\sin\theta \cos\phi \cos\Omega - \cos\theta \sin\Omega] \hat{y} \\ &+ f(r) \sin\theta \sin\phi \sin\Omega \hat{z} = \hat{x} j_x + \hat{y} j_y + \hat{z} j_z \end{aligned}$$

(Since the two integrals have the same mathematical form, the subscripts will be temporarily suppressed, with the pairings $\vec{j}_0 \leftrightarrow \vec{h}_L$ and $\vec{j}_L \leftrightarrow \vec{h}_0$ understood.) Then for either integral,

$$\begin{aligned} \vec{N}^{(i)} &= \hat{x} \frac{1}{c} \int_v d^3r [r \sin\theta \sin\phi j_x h_y - r \sin\theta \sin\phi j_y h_x - r \cos\theta j_z h_x + r \cos\theta j_x h_z] \\ &+ \hat{y} \frac{1}{c} \int_v d^3r [-r \sin\theta \cos\phi j_x h_y + r \sin\theta \cos\phi j_y h_x + r \cos\theta j_y h_z - r \cos\theta j_z h_y] \\ &+ \hat{z} \frac{1}{c} \int_v d^3r [r \sin\theta \cos\phi j_z h_x - r \sin\theta \cos\phi j_x h_z - r \sin\theta \sin\phi j_y h_z \\ &\quad + r \sin\theta \sin\phi j_z h_y] \end{aligned}$$

Substituting for the components of \vec{j} and \vec{h} from above and integrating over θ and ϕ gives

$$\vec{N}^{(i)} = \hat{y} \left[-\frac{4\pi}{3c} \sin\Omega \int_0^R dr r^3 f(r) F(r) \right]$$

Thus each of the torques lies along the y-axis of its coordinate system. Since the y-axes coincide, the two torques can be added (after the change $\Omega \rightarrow -\Omega$ for the second integral) to give the total torque:

$$\vec{N} = \vec{N}^{(1)} + \vec{N}^{(2)} = \hat{y} \left[-\frac{4\pi}{3c} \sin\Omega \int_0^R r^3 f_0(r) F_L(r) dr + \frac{4\pi}{3c} \sin\Omega \int_0^R r^3 f_L(r) F_0(r) dr \right]$$

The term $\vec{N}^{(1)}$ can be viewed as the shielding current interacting with the London field and the term $\vec{N}^{(2)}$ as the London current interacting with the external field penetrating the superconductor.

Substituting from Section IIIB yields

$$N^{(1)} = \frac{m^*c}{e^*} \omega B_0 \sin\Omega \left[\frac{R}{\sinh \beta R} \int_0^R r(\sinh \beta r - \beta r \cosh \beta r) dr + \frac{3R^2}{\beta^2 \sinh^2 \beta R} \int_0^R \frac{dr}{r^2} (\sinh \beta r - \beta r \cosh \beta r)^2 \right]$$

and

$$N^{(2)} = -\frac{m^*c}{e^*} \omega B_0 \sin\Omega \frac{3R^2}{\beta^2 \sinh^2 \beta R} \int_0^R \frac{dr}{r^2} (\sinh \beta r - \beta r \cosh \beta r)^2$$

Thus,

$$|\vec{N}| = N^{(1)} + N^{(2)} = \frac{m^*c}{e^*} \omega B_0 \sin\Omega \frac{R}{\sinh \beta R} \int_0^R r(\sinh \beta r - \beta r \cosh \beta r) dr$$

Carrying out the integration, one obtains the exact result:

$$|\vec{N}| = \frac{m^*c}{e^*} R^3 \omega B_0 \sin\Omega \left(1 - \frac{3 \cosh \beta R}{\beta R \sinh \beta R} + \frac{3}{\beta^2 R^2} \right)$$

The result can be written in vector form as:

$$\begin{aligned} \vec{N} &= \vec{M} \times \vec{B}_0 \\ \vec{M} &= \left(1 - \frac{3 \cosh \beta R}{\beta R \sinh \beta R} + \frac{3}{\beta^2 R^2} \right) \frac{m^*c}{e^*} R^3 \vec{\omega} \end{aligned}$$

where \vec{M} is the London moment.

For a rotation frequency of 200 Hz ($\omega = 400\pi$ rad/s), a field strength of 1 microgauss, and a rotor radius of 2 cm, the maximum torque is

$$N_{\max} \cong \frac{m^*c}{e^*} R^3 \omega B_0 \cong 5 \times 10^{-10} \text{ dyne-cm}$$

$$N_{\max} \cong 5 \times 10^{-17} \text{ N m}$$

Note that

$$\frac{|\vec{N}^{(2)}|}{|\vec{N}^{(1)}|} \sim \frac{\lambda}{R} \sim 5 \times 10^{-6}$$

which means that the interaction of the London current with the external field penetrating the superconductor is negligible in comparison with shielding currents interacting with the London field. This is quite reasonable: In $\vec{N}^{(2)}$, \vec{j}_L and \vec{h}_0 both become exponentially small at distances from the surface which are large compared to λ , but in $\vec{N}^{(1)}$ only \vec{j}_0 becomes exponentially small.

D. Rotating Superconducting Spherical Shell

The solution to London's equations for a hollow superconducting sphere rotating with constant angular velocity (no external fields) has been calculated by J. H. Derrickson⁵ of NASA and others⁶ [11]. The results are:

$$\vec{j} = \frac{n_s e^*}{r^2} [A(\sinh \beta r - \beta r \cosh \beta r) + B(\cosh \beta r - \beta r \sinh \beta r)] \sin \theta \hat{\phi} \quad ;$$

$$\left. \begin{aligned} h_r &= \frac{2M}{r^3} \cos \theta \\ h_\theta &= \frac{M}{r^3} \sin \theta \\ h_\phi &= 0 \end{aligned} \right\} \quad r \geq R_0 \quad ,$$

$$\left. \begin{aligned} h_r &= \frac{m^* c}{e^*} \left[2\omega + \frac{2A}{r^3} (\sinh \beta r - \beta r \cosh \beta r) + \frac{2B}{r^3} (\cosh \beta r - \beta r \sinh \beta r) \right] \cos \theta \\ h_\theta &= \frac{m^* c}{e^*} \left\{ -2\omega + \frac{A}{r^3} [(1 + \beta^2 r^2) \sinh \beta r - \beta r \cosh \beta r] \right. \\ &\quad \left. + \frac{B}{r^3} [(1 + \beta^2 r^2) \cosh \beta r - \beta r \sinh \beta r] \right\} \sin \theta \\ h_\phi &= 0 \end{aligned} \right\} \quad R_1 \leq r \leq R_0 \quad ,$$

5. Derrickson, J. H.: The Magnetic Field Generated by a Superconducting Spherical Shell Rotating with Constant Angular Velocity. MSFC IN-SSL-N-70-9, July 27, 1970.

6. Pondrom, W. L., Jr.: London Moment of a Rotating Hollow Superconducting Sphere. Unpublished Report.

$$\left. \begin{aligned} h_r &= H_0 \cos\theta \\ h_\theta &= -H_0 \sin\theta \\ h_\phi &= 0 \end{aligned} \right\} \quad r \leq R_i$$

Here R_0 is the outer radius of the shell, R_i is the inner radius and the constants M , A , B , and H_0 are given by:

$$A = \frac{3\omega R_0}{\beta^2} \frac{[(3 + \beta^2 R_i^2) \cosh \beta R_i - 3 \beta R_i \sinh \beta R_i]}{[(3 + \beta^2 R_i^2) \sinh \beta(R_0 - R_i) + 3 \beta R_i \cosh \beta(R_0 - R_i)]}$$

$$B = \frac{3\omega R_0}{\beta^2} \frac{[3 \beta R_i \cosh \beta R_i - (3 + \beta^2 R_i^2) \sinh \beta R_i]}{[(3 + \beta^2 R_i^2) \sinh \beta(R_0 - R_i) + 3 \beta R_i \cosh \beta(R_0 - R_i)]}$$

$$H_0 = \frac{2m^*c\omega}{e^*} \left[1 - \frac{3 \beta R_0}{(3 + \beta^2 R_i^2) \sinh \beta(R_0 - R_i) + 3 \beta R_i \cosh \beta(R_0 - R_i)} \right]$$

$$M = \frac{m^*c \omega R_0^3}{e^*} \left\{ 1 + \frac{3}{\beta^2 R_0^2} - \frac{3}{\beta R_0} \left[\frac{(3 + \beta^2 R_i^2) \cosh \beta(R_0 - R_i) + 3 \beta R_i \sinh \beta(R_0 - R_i)}{(3 + \beta^2 R_i^2) \sinh \beta(R_0 - R_i) + 3 \beta R_i \cosh \beta(R_0 - R_i)} \right] \right\}$$

In the limit $R_i \rightarrow 0$, these results approach those computed by London for a rotating solid sphere of radius R_0 (see Section IIIB). In the limit $\beta R_i \gg 1$ and $\beta(R_0 - R_i) \gg 1$ the result approaches that for a solid sphere whose radius is much larger than the penetration depth.

A limit of special interest is $\beta R_0 \gg 1$ with $R_i \rightarrow R_0$. Calling $R_0 - R_i = d$, one has

$$H_0 \simeq \frac{2m^*c\omega}{e^*} \left[\frac{(\beta^2 R_0 d/3)}{1 + (\beta^2 R_0 d/3)} \right] \rightarrow \frac{2m^*c\omega}{e^*} \frac{\beta^2 R_0 d}{3}$$

$$M \simeq \frac{m^*c}{e^*} \omega R_0^3 \left[\frac{(\beta^2 R_0 d/3)}{1 + (\beta^2 R_0 d/3)} \right] \rightarrow \frac{m^*c\omega R_0^3}{e^*} \frac{\beta^2 R_0 d}{3}$$

$$\vec{j} \rightarrow -n_s e^* \omega R_0 \sin\theta \hat{\phi}$$

In this limit the current density and fields approach those of a rotating charge shell of density $\sigma = -n_s e^* d$ and total charge $Q = 4\pi R_0^2 d n_s e^*$. The superelectrons are thus nearly stationary in the lab frame and move with a velocity $v_s = -\omega R_0 \sin\theta$ with respect to the lattice, so that a reasonable requirement is that the current density not exceed the critical current density; i.e., it is required that $|n_s e^* \omega R_0| < j_c$, where j_c is the critical current density. From the Landau-Ginzburg theory for a thin plane superconductor, one obtains [4]:

$$j_c(T) = \frac{c \Phi_0}{12 \sqrt{3} \pi^2 \lambda^2(T) \xi(T)}$$

where Φ_0 is the flux quantum. Using $n_s e^* \omega R_0 = m^* c^2 \omega R_0 / 4\pi e^* \lambda^2$, the requirement becomes

$$f = \frac{\omega}{2\pi} < \frac{-e \Phi_0}{6 \sqrt{3} \pi^2 m c R_0 \xi(T)} \simeq \frac{0.018}{\xi(T)} \text{ Hz}$$

Therefore, it appears that a thin rotating shell gives the full London moment, provided the rotation frequency is not too large and provided the pair density is essentially that of a bulk superconductor. The latter condition is equivalent to the requirement that

$$d > \xi(0) \sim 400 \text{ \AA}$$

E. Effect of Excess Charge on the Rotor

An excess charge on a superconducting sphere at rest will be uniformly distributed on the surface. The requirement that the tangential component of \vec{e} be

continuous at the surface means this will also be true for a rotating superconducting sphere. If the total charge is Q , the surface charge density is $\sigma = Q/4\pi R^2$. At steady state this charge rotates with the lattice, constituting a current density

$$\vec{J} = \sigma r \omega \sin\theta \delta(r - R) \hat{\phi}$$

The vector potential \vec{A} is then

$$\vec{A}(\vec{r}) = \frac{1}{c} \int d^3 r' \frac{\vec{J}(\vec{r}')}{|\vec{r} - \vec{r}'|}$$

The expansion of $|\vec{r} - \vec{r}'|^{-1}$ in spherical harmonics is [10]:

$$\frac{1}{|\vec{r} - \vec{r}'|} = 4\pi \sum_{\ell=0}^{\infty} \sum_{m=-\ell}^{\ell} \frac{1}{2\ell+1} \frac{r_{<}^{\ell}}{r_{>}^{\ell+1}} Y_{\ell m}^*(\theta', \phi') Y_{\ell m}(\theta, \phi),$$

where $r_{<}$ ($r_{>}$) is the smaller (larger) of $|\vec{r}|$ and $|\vec{r}'|$. Using the relation $\hat{\phi} = -\sin\phi \hat{x} + \cos\phi \hat{y}$, the evaluation of the integral for $\vec{A}(\vec{r})$ is straightforward. The result is

$$\vec{A}(\vec{r}) = \frac{4\pi}{c} \frac{\sigma\omega R^4}{3r^2} \sin\theta \hat{\phi}, \quad r \geq R,$$

and

$$\vec{A}(\vec{r}) = \frac{4\pi}{c} \frac{\sigma\omega Rr}{3} \sin\theta \hat{\phi}, \quad r \leq R.$$

From $\vec{B} = \text{curl } \vec{A}$ the magnetic field is

$$\left. \begin{aligned}
B_r &= \frac{2Q\omega}{3Rc} \left(\frac{R}{r}\right)^3 \cos\theta \\
B_\theta &= \frac{Q\omega}{3Rc} \left(\frac{R}{r}\right)^3 \sin\theta \\
B_\phi &= 0 \\
B_r &= \frac{2Q\omega}{3Rc} \cos\theta \\
B_\theta &= -\frac{2Q\omega}{3Rc} \sin\theta \\
B_\phi &= 0
\end{aligned} \right\} \begin{array}{l} r \geq R \\ \\ \\ r \leq R \end{array}$$

The field inside the charge shell is a uniform field parallel to $\vec{\omega}$; since this field is due to "external" sources, the solutions to the London equations are those of a sphere rotating in a uniform applied field. By appeal to the theorem, one can then write down the solution from the results of Section IIIB:

For $r \leq R$,

$$\begin{aligned}
h_r &= \frac{m^*c}{e^*} \left\{ 2\omega + \frac{6\omega R}{\beta^2 r^3 \sinh \beta R} \left[1 - \frac{(Qe^*/R)}{3m^*c^2} \right] (\sinh \beta r - \beta r \cosh \beta r) \right\} \cos\theta, \\
h_\theta &= \frac{m^*c}{e^*} \left\{ -2\omega + \frac{3\omega R}{\beta^2 r^3 \sinh \beta R} \left[1 - \frac{(Qe^*/R)}{3m^*c^2} \right] [(1 + \beta^2 r^2) \sinh \beta r - \beta r \cosh \beta r] \right\} \sin\theta, \\
h_\phi &= 0.
\end{aligned}$$

The field outside the rotating superconductor will be the superposition of the field due to the supercurrent and the field due to the rotating charge layer:

$$\begin{aligned}
h_r &= \frac{2m^*c\omega}{e^*} \left(\frac{R}{r}\right)^3 \left(1 - \frac{3 \cosh \beta R}{\beta R \sinh \beta R} + \frac{3}{\beta^2 R^2}\right) \cos\theta \\
&\quad + \frac{2\omega Q}{3Rc} \left(\frac{R}{r}\right)^3 \left(\frac{3 \cosh \beta R}{\beta R \sinh \beta R} - \frac{3}{\beta^2 R^2}\right) \cos\theta, \\
h_\theta &= \frac{m^*c\omega}{e^*} \left(\frac{R}{r}\right)^3 \left(1 - \frac{3 \cosh \beta R}{\beta R \sinh \beta R} + \frac{3}{\beta^2 R^2}\right) \sin\theta \\
&\quad + \frac{\omega Q}{3Rc} \left(\frac{R}{r}\right)^3 \left(\frac{3 \cosh \beta R}{\beta R \sinh \beta R} - \frac{3}{\beta^2 R^2}\right) \sin\theta,
\end{aligned}$$

$$h_\phi = 0$$

For $Q = Ne$ the relative magnitudes are

$$\frac{\left| \frac{m^*c}{e^*} \omega R^3 \right|}{\left| \frac{Q\omega R^3}{3Rc} \frac{3 \cosh \beta R}{\beta R \sinh \beta R} \right|} \approx \frac{mc^2}{(e^2/R)} \frac{R}{\lambda} \frac{1}{N} \sim \frac{10^{18}}{N}$$

so the direct effect of a small excess charge is negligible. These results are easy to understand: The rotating surface charge generates a dipole field outside and a uniform field inside the superconductor; a supercurrent flows to exclude (cancel) the uniform magnetic field from the interior of the superconductor, generating a uniform field inside and a dipole field outside. The net result is that these fields cancel everywhere to at least order λ/R .

For completeness, the current density \vec{j} in the superconductor is

$$\vec{j} = \frac{3 n_s e^* \omega R}{\beta^2 r^2 \sinh \beta R} \left(1 - \frac{Qe^*/R}{3m^*c^2}\right) (\sinh \beta r - \beta r \cosh \beta r) \sin\theta \hat{\phi}$$

Josephson has argued [12] that m^* is the rest mass corrected by the work function W , the energy difference between free space and the Fermi surface; i.e., that it is the total energy, $m^*c^2 = 2m_0c^2 - 2W$, necessary to create a pair in the metal which determines the relevant mass m^* . Since the addition of charge Q to an isolated superconducting sphere increases the potential by Q/R , the work function becomes

$W = W_0 + Qe^*/2R$. If Josephson's argument is correct, this means the addition of charge could significantly change the London moment through m^* .

IV. CALCULATIONS USING CLASSICAL ELECTRODYNAMICS WITH THE ASSUMPTION OF A PERFECT MEISSNER EFFECT

A. Introduction to a Macroscopic Approach

The Meissner-Ochsenfeld experiment indicated that the magnetic induction \vec{B} vanishes inside an ideal superconductor. Meissner's result is contained in the London theory, with the plausible restriction that the magnetic induction does not vanish discontinuously at the surface, but instead it decreases to nearly zero over a distance of order λ , the penetration depth. The thermodynamic magnetic induction \vec{B} is defined as the volume average of the local field $\vec{h}(\vec{r})$, so that for large bodies, $\vec{B} = 0$ in the interior.

The general boundary condition for the magnetic induction \vec{B} at a surface is

$$(\vec{B}_2 - \vec{B}_1) \cdot \hat{n} = 0$$

where \hat{n} is a unit vector normal to the surface. If the Meissner result is used, then, with \vec{B} the external induction and \hat{n} the outward normal, the boundary condition at the surface of a superconductor becomes $\vec{B} \cdot \hat{n} = 0$. Use of this boundary condition for superconductors whose dimensions R are large compared to λ gives values for the external magnetic induction which are correct to order λ/R .

As an example, consider the case of the sphere in uniform applied field \vec{B}_0 . The external magnetic induction can be derived from a scalar potential Φ . Choosing the origin of the coordinate system at the center of the sphere with the z-axis parallel to \vec{B}_0 , symmetry requires that Φ have the form

$$\Phi = \sum_{\ell=0}^{\infty} \left[\alpha_{\ell} r^{\ell} + \beta_{\ell} r^{-(\ell+1)} \right] P_{\ell}(\cos\theta) ,$$

where the functions $P_{\ell}(\cos\theta)$ are the Legendre polynomials [10]. As $|\vec{r}| \rightarrow \infty$,

$$\vec{B} = -\text{grad } \Phi \rightarrow -\alpha_1 \hat{z} - \text{grad} \left[\sum_{\ell=2}^{\infty} \alpha_{\ell} r^{\ell} P_{\ell}(\cos\theta) \right] ,$$

but as $|\vec{r}| \rightarrow \infty$, $\vec{B} \rightarrow \vec{B}_0$, which requires that $\alpha_1 = -B_0$ and $\alpha_\ell = 0$ for $\ell > 1$. Thus, Φ becomes

$$\Phi = -B_0 r \cos\theta + \sum_{\ell=0}^{\infty} \beta_\ell r^{-(\ell+1)} P_\ell(\cos\theta)$$

At the surface of the sphere, $\vec{B} \cdot \hat{n} = B_r(r=R) = 0$, so that

$$0 = -\left. \frac{\partial \Phi}{\partial r} \right|_{r=R} = B_0 \cos\theta + \sum_{\ell=0}^{\infty} (\ell+1) \beta_\ell R^{-(\ell+2)} P_\ell(\cos\theta)$$

Orthogonality of the Legendre polynomials gives $\beta_\ell = 0$ for $\ell \neq 1$, and $\beta_1 = -(B_0 R^3/2)$. Hence the result

$B_r = \left(B_0 - \frac{B_0 R^3}{r^3} \right) \cos\theta$,
$B_\theta = - \left(B_0 + \frac{B_0 R^3}{2r^3} \right) \sin\theta$,
$B_\phi = 0$.

It is seen that this result agrees with the exact result (Section IIIB) to order λ/R .

The condition $\vec{B} \cdot \hat{n} = 0$ holds only for externally applied fields in the case of a rotating superconductor; the rotating superconductor generates a magnetic induction which has a nonzero normal component. For a rotating superconducting sphere with the origin of the coordinate system at the center of the sphere, the boundary condition for \vec{B} becomes

$$\vec{B} \cdot \hat{n} = \frac{2M}{R^3} (\hat{\omega} \cdot \hat{r})$$

where $M = (m^* c/e^*)\omega R^3$. This reduces to $\vec{B} \cdot \hat{n} = 0$ for $\omega = 0$. Inside the rotating sphere, the thermodynamic magnetic induction is

$$\vec{B} = \frac{2m^*c}{e^*} \vec{\omega} \quad ,$$

which reduces to $\vec{B} = 0$ for $\vec{\omega} = 0$.

In the complete Meissner region, the thermodynamic magnetic field \vec{H} is undefined. One may define \vec{H} [and concomitantly the magnetization \vec{m} through $4\pi\vec{m} = (\vec{B}-\vec{H})$] so long as the definition is consistent with thermodynamics and macroscopic electromagnetic theory. From Maxwell's equation (I) at steady state, one has for any surface S bounded by a curve C ,

$$\oint_C \vec{H} \cdot d\vec{\ell} = \frac{4\pi}{c} \int_S \vec{j} \cdot d\vec{s}$$

In a superconductor, currents flow within order λ of the surface, so that $\vec{j} = 0$ deep within the superconductor. Then for any arbitrary small closed path C deep within the superconductor, $\oint_C \vec{H} \cdot d\vec{\ell} = 0$, and the choice $\vec{H} = \vec{B} = 0$ in the interior is self consistent.

The general boundary condition for \vec{H} is

$$\hat{n} \times (\vec{H}_2 - \vec{H}_1) = \frac{4\pi}{c} \vec{K} \quad ,$$

where \vec{K} is the surface current density. The boundary condition thus becomes

$$\hat{n} \times \vec{H} = \frac{4\pi}{c} \vec{K}$$

at the surface of a superconductor, where \vec{H} is the external magnetic field.

Continuing with the example of the sphere, one has $\vec{H} = \vec{B}$ ($\mu = 1$) outside the superconductor, so that

$$\vec{K} = \frac{c}{4\pi} (\hat{n} \times \vec{B})_{r=R} = \frac{c}{4\pi} B_\theta (r=R) \hat{\phi} \quad ,$$

or

$$\boxed{\vec{K} = -\frac{c}{4\pi} \frac{3B_0}{2} \sin\theta \hat{\phi}}$$

From Section IIIB, one has for the current density

$$\vec{j} = -\frac{c}{4\pi} \frac{3B_0}{2r^2} \frac{R}{\sinh \beta R} (\sinh \beta r - \beta r \cosh \beta r) \sin\theta \hat{\phi}$$

Integrating

$$\begin{aligned} \int_0^R j_\phi dr &= -\frac{c}{4\pi} \frac{3B_0}{2} \frac{R \sin\theta}{\sinh \beta R} \int_0^R (r^{-2} \sinh \beta r - \beta r^{-1} \cosh \beta r) dr \\ &= \frac{c}{4\pi} \frac{3B_0}{2} \sin\theta \left(1 - \frac{\beta R}{\sinh \beta R} \right) \xrightarrow{\beta R \gg 1} \frac{c}{4\pi} \frac{3B_0}{2} \sin\theta \end{aligned}$$

The current density \vec{j} is appreciable only within a distance of order λ of the surface, and the equation $\vec{K} = \frac{c}{4\pi} [\hat{n} \times \vec{H}]$ implies that this current is treated as a true surface current.

That is, to within λ/R , \vec{K} is just the integrated value of the current density obtained by solving London's equations. (The apparent difference in sign is caused by the fact that \vec{j} is the electron current density ($j \propto e^* < 0$), whereas the macroscopic theory, as usual, assumes positive charge carriers.)

For the rotating sphere it will also be assumed that $\mu = 1$ (i.e., take $\vec{B} = \vec{H}$) in the interior, so that the boundary condition becomes

$$\hat{n} \times [\vec{H} - (2m^*c/e^*)\vec{\omega}] = (4\pi/c)\vec{K} \quad ,$$

where \vec{H} is the external field. The choice $\mu = 1$ is consistent with the London theory as well as thermodynamics and classical electrodynamics. It is seen that the stationary superconductor ($\omega = 0$) is a special case of the above.

The mode of attack for torque calculations will be as follows: The magnetic induction \vec{B} in the region between the rotor and the shield will be calculated as the gradient of a scalar potential and will be evaluated using the boundary conditions:

$$\vec{B} \cdot \hat{n} = \frac{2M}{R^3} (\hat{\omega} \cdot \hat{r}) \quad \text{at the surface of the rotor,}$$

$$\vec{B} \cdot \hat{n} = 0 \quad \text{at other superconducting surfaces.}$$

Since $\vec{B} = \vec{H}$, the rotor surface currents can be calculated when \vec{B} is known:

$$\vec{K} = \frac{c}{4\pi} \hat{n} \times \left(\vec{B} - \frac{2m^*c}{e^*} \vec{\omega} \right)$$

The torque can then be calculated using

$$\vec{N} = \frac{R^3}{c} \int_{\phi=0}^{2\pi} d\phi \int_{\theta=0}^{\pi} d\theta \sin\theta [\hat{r} \times (\vec{K} \times \vec{B})]$$

As a final example, the torque on a superconducting sphere in a uniform applied field is calculated. Choose \hat{z} parallel to \vec{B}_0 and \hat{y} perpendicular to the plane defined by \vec{B}_0 and $\vec{\omega}$. Requiring $\vec{B} \rightarrow \vec{B}_0$ as $\vec{r} \rightarrow \infty$ and using the boundary condition $\vec{B} \cdot \hat{n} = (2M/R^3) (\hat{\omega} \cdot \hat{r})$ at the surface of the sphere, the scalar potential is

$$\begin{aligned}\Phi &= -B_0 r \cos\theta - \frac{B_0 R^3}{2r^2} \cos\theta + \frac{4\pi}{3} \frac{M}{r^2} \sum_{m=-1}^1 Y_{1m}^*(\Omega, 0) Y_{1m}(\theta, \phi) \\ &= -B_0 r \cos\theta - \frac{B_0 R^3}{2r^2} \cos\theta + \frac{M}{r^2} (\sin\Omega \sin\theta \cos\phi + \cos\Omega \cos\theta) \quad ,\end{aligned}$$

where Ω is the angle between \vec{B}_0 and $\vec{\omega}$, and the functions $Y_{\ell m}(\theta, \phi)$ are the spherical harmonics as defined by Jackson [10].

The components of the magnetic induction $\vec{B} = -\text{grad } \Phi$ are

$$B_r = \left(1 - \frac{R^3}{r^3}\right) B_0 \cos\theta + \frac{2M}{r^3} (\sin\Omega \sin\theta \cos\phi + \cos\Omega \cos\theta) \quad ,$$

$$B_\theta = -\left(1 + \frac{R^3}{2r^3}\right) B_0 \sin\theta - \frac{M}{r^3} (\sin\Omega \cos\theta \cos\phi - \cos\Omega \sin\theta) \quad ,$$

$$B_\phi = \frac{M}{r^3} \sin\Omega \sin\phi \quad .$$

In vector notation,

$$\vec{B} = B_0 \hat{z} - \frac{B_0 R^3}{2r^3} [3(\hat{r} \cdot \hat{z}) \hat{r} - \hat{z}] + \frac{M}{r^3} [3(\hat{\omega} \cdot \hat{r}) \hat{r} - \hat{\omega}]$$

The internal magnetic field \vec{H} is $\vec{H} = (2 m^* c / e^*) \vec{\omega} = \frac{2M}{R^3} \hat{\omega}$, so that the surface current is

$$\begin{aligned}\vec{K} &= \frac{c}{4\pi} \hat{r} \times \left\{ B_0 \hat{z} - \frac{B_0}{2} [3(\hat{r} \cdot \hat{z}) \hat{r} - \hat{z}] + \frac{M}{R^3} [3(\hat{r} \cdot \hat{\omega}) \hat{r} - \hat{\omega}] - \frac{2M}{R^3} \hat{\omega} \right\} \\ &= \frac{c}{4\pi} \left[\frac{3B_0}{2} (\hat{r} \times \hat{z}) - \frac{3M}{R^3} (\hat{r} \times \hat{\omega}) \right] \quad .\end{aligned}$$

The torque \vec{N} is then given by

$$\vec{N} = \frac{R^3}{c} \int_{\phi=0}^{2\pi} d\phi \int_{\theta=0}^{\pi} d\theta \sin\theta \hat{r} \times \left\{ \frac{c}{4\pi} \left[\frac{3B_0}{2} (\hat{r} \times \hat{z}) - \frac{3M}{R^3} (\hat{r} \times \hat{\omega}) \right] \right. \\ \left. \times \left[B_0 \hat{z} - \frac{B_0}{2} [3(\hat{r} \cdot \hat{z}) \hat{r} - \hat{z}] + \frac{M}{R^3} [3(\hat{r} \cdot \hat{\omega}) \hat{r} - \hat{\omega}] \right] \right\}$$

There are six vector products in \vec{N} :

$$1. \quad \hat{r} \times [(\hat{r} \times \hat{z}) \times \hat{z}] = (\hat{r} \cdot \hat{z}) (\hat{r} \times \hat{z}) \quad ,$$

$$2. \quad \hat{r} \times [(\hat{r} \times \hat{z}) \times \hat{r}] = (\hat{r} \times \hat{z}) \quad ,$$

$$3. \quad \hat{r} \times [(\hat{r} \times \hat{\omega}) \times \hat{\omega}] = (\hat{\omega} \cdot \hat{r}) (\hat{r} \times \hat{\omega}) \quad ,$$

$$4. \quad \hat{r} \times [(\hat{r} \times \hat{\omega}) \times \hat{z}] = (\hat{r} \cdot \hat{z}) (\hat{r} \times \hat{\omega}) \quad ,$$

$$5. \quad \hat{r} \times [(\hat{r} \times \hat{\omega}) \times \hat{r}] = (\hat{r} \times \hat{\omega}) \quad ,$$

$$6. \quad \hat{r} \times [(\hat{r} \times \hat{\omega}) \times \hat{\omega}] = (\hat{\omega} \cdot \hat{r}) (\hat{r} \times \hat{\omega}) \quad .$$

Terms 1, 2, 5, and 6 integrate to zero. Integrating 3 gives

$$\int_0^{2\pi} d\phi \int_0^{\pi} d\theta \sin\theta (\hat{\omega} \cdot \hat{r}) (\hat{r} \times \hat{\omega}) \\ = -\hat{z} \times \int_0^{2\pi} d\phi \int_0^{\pi} d\theta \sin\theta (\sin\Omega \sin\theta \cos\phi + \cos\Omega \cos\theta) (\hat{x} \sin\theta \cos\phi + \hat{y} \sin\theta \sin\phi + \hat{z} \cos\theta) \\ = -\hat{z} \times \left[\sin\Omega \int_0^{\pi} d\theta \sin^3\theta \int_0^{2\pi} d\phi \cos\phi (\hat{x} \cos\phi + \hat{y} \sin\phi) \right] = -\frac{4\pi}{3} \sin\Omega \hat{y}$$

Similarly, integrating 4 gives

$$\int_0^{2\pi} d\phi \int_0^\pi d\theta (\hat{z} \cdot \hat{r}) (\hat{r} \times \hat{\omega}) = \frac{4\pi}{3} \sin\Omega \hat{y}$$

Thus the torque \vec{N} is

$$\begin{aligned} \vec{N} &= \frac{R^3}{c} \frac{c}{4\pi} \left[\frac{3B_0}{2} \left(-\frac{M}{R^3} \right) \left(-\frac{4\pi}{3} \sin\Omega \right) + \left(-\frac{3M}{R^3} \right) \left(\frac{3B_0}{2} \right) \frac{4\pi}{3} \sin\Omega \right] \hat{y} \\ &= -B_0 M \sin\Omega \hat{y} \end{aligned}$$

In vector notation,

$$\boxed{\vec{N} = \vec{M} \times \vec{B}_0, \quad \vec{M} = (m^*c/e^*) R^3 \vec{\omega}}$$

which agrees with the exact solution to order λ/R .

B. Torque on a Rotating Superconducting Sphere in an Arbitrary Magnetic Field

Using this macroscopic theory, the rotor torque in an arbitrary magnetic field can be calculated. Let S be the distance between the center of the rotor and the nearest external current or superconducting surface. Then in the volume defined by $R < |\vec{r}| < S$, the magnetic induction \vec{B} can be derived from a scalar potential Φ through $B = -\text{grad } \Phi$. The boundary condition

$$\vec{B} \cdot \hat{n} = \frac{2M}{R^3} (\hat{\omega} \cdot \hat{r})$$

at the surface of the rotor requires the scalar potential to have the general form

$$\Phi(r, \theta, \phi; \Omega, \phi_0) = \frac{4\pi}{3} M r^{-2} \sum_{k=-1}^1 Y_{1k}^*(\Omega, \phi_0) Y_{1k}(\theta, \phi) \\ + \sum_{\ell=1}^{\infty} \sum_{m=-\ell}^{\ell} \alpha_{\ell m} \left[r^{\ell} + \left(\frac{\ell}{\ell+1} \right) R^{2\ell+1} r^{-(\ell+1)} \right] Y_{\ell m}(\theta, \phi) ,$$

where Ω is the angle between $\vec{\omega}$ and the z-axis, ϕ_0 is the angle between the x-axis and the projection of $\vec{\omega}$ in the x-y plane, M is the London moment [$M = (m^* c/e^*) \omega R^3$], and the functions $Y_{\ell m}(\theta, \phi)$ are the spherical harmonics.

The scalar potential for an isolated rotating sphere is

$$\Phi_L = \frac{4\pi}{3} M r^{-2} \sum_{k=-1}^1 Y_{1k}^*(\Omega, \phi_0) Y_{1k}(\theta, \phi) ,$$

so that one can write $\Phi = \Phi_L + \Phi_0$. The magnetic induction \vec{B} is $\vec{B} = -\text{grad}\Phi = -\text{grad}\Phi_L - \text{grad}\Phi_0 = \vec{B}_L + \vec{B}_0$. ($\vec{B}_0 \equiv \vec{B} - \vec{B}_L$ should not be confused with the uniform applied field considered earlier.) The components of \vec{B} are

$$B_r = -\frac{\partial\Phi}{\partial r} = \frac{8\pi}{3} \frac{M}{r^3} \sum_{k=-1}^1 Y_{1k}^*(\Omega, \phi_0) Y_{1k}(\theta, \phi) \\ - \sum_{\ell=1}^{\infty} \sum_{m=-\ell}^{\ell} \ell \alpha_{\ell m} \left[r^{\ell-1} - R^{2\ell+1} r^{-(\ell+2)} \right] Y_{\ell m}(\theta, \phi) , \\ B_{\theta} = -\frac{1}{r} \frac{\partial\Phi}{\partial\theta} = -\frac{4\pi}{3} \frac{M}{r^3} \sum_{k=-1}^1 Y_{1k}^*(\Omega, \phi_0) \frac{\partial}{\partial\theta} Y_{1k}(\theta, \phi) \\ - \sum_{\ell=1}^{\infty} \sum_{m=-\ell}^{\ell} \alpha_{\ell m} \left[r^{\ell-1} + \left(\frac{\ell}{\ell+1} \right) R^{2\ell+1} r^{-(\ell+2)} \right] \frac{\partial}{\partial\theta} Y_{\ell m}(\theta, \phi) ,$$

$$B_\phi = -\frac{1}{r \sin\theta} \frac{\partial\Phi}{\partial\phi} = -\frac{4\pi M}{3 r^3 \sin\theta} \sum_{k=-1}^1 Y_{1k}^*(\Omega, \phi_0) \frac{\partial}{\partial\phi} Y_{1k}(\theta, \phi) \\ - \sum_{\ell=1}^{\infty} \sum_{m=-\ell}^{\ell} \frac{\alpha_{\ell m}}{\sin\theta} \left[r^{\ell-1} + \left(\frac{\ell}{\ell+1}\right) R^{2\ell+1} r^{-(\ell+2)} \right] \frac{\partial}{\partial\phi} Y_{\ell m}(\theta, \phi)$$

Since \vec{B}_0 is real, $\alpha_{\ell m}^* = (-1)^m \alpha_{\ell, -m}$.

Because $\vec{B} = \vec{B}_0 + \vec{B}_L$, $\vec{K} = \vec{K}_0 + \vec{K}_L$, where

$$\vec{K}_0 = \frac{c}{4\pi} \hat{n} \times \vec{B}_0$$

$$\vec{K}_L = \frac{c}{4\pi} \hat{n} \times \left(\vec{B}_L - \frac{2 m^* c}{e^*} \vec{\omega} \right) = -\frac{c}{4\pi} \frac{3M}{R^3} (\hat{r} \times \hat{\omega})$$

Quite generally,

$$\vec{N} = \frac{R^3}{c} \int d\Omega' [\hat{r} \times (\vec{K} \times \vec{B})] = \frac{R^3}{c} \int d\Omega' \left\{ \hat{r} \times [(\vec{K}_0 \times \vec{B}_L) + (\vec{K}_L \times \vec{B}_0)] \right\},$$

where $d\Omega'$ is the differential of solid angle. But $\hat{r} \times (\vec{K}_L \times \vec{B}_0) = -\frac{c}{4\pi} \frac{3M}{R^3} (\vec{B}_0 \cdot \hat{r}) (\hat{r} \times \hat{\omega}) = 0$, since $\vec{B}_0 \cdot \hat{r} = 0$ at $r = R$. Thus

$$\boxed{\vec{N} = \frac{R^3}{c} \int d\Omega' [\hat{r} \times (\vec{K}_0 \times \vec{B}_L)]}$$

Since

$$\hat{r} \times (\vec{K}_0 \times \vec{B}_L) = \frac{c}{4\pi} [\hat{\theta} (-B_\phi^0 B_r^L) + \hat{\phi} (B_\theta^0 B_r^L)]$$

$$\vec{N} = \frac{R^3}{4\pi} \int_0^{2\pi} d\phi \int_0^\pi d\theta \sin\theta [\hat{\theta} (-B_\phi^0 B_r^L) + \hat{\phi} (B_\theta^0 B_r^L)]$$

The evaluation of the integral is straightforward but tedious. Recall that

$$\begin{aligned} \hat{r} \cdot \hat{x} &= \sin\theta \cos\phi & \hat{\theta} \cdot \hat{x} &= \cos\theta \cos\phi & \hat{\phi} \cdot \hat{x} &= -\sin\phi \\ \hat{r} \cdot \hat{y} &= \sin\theta \sin\phi & \hat{\theta} \cdot \hat{y} &= \cos\theta \sin\phi & \hat{\phi} \cdot \hat{y} &= \cos\phi \\ \hat{r} \cdot \hat{z} &= \cos\theta & \hat{\theta} \cdot \hat{z} &= -\sin\theta & \hat{\phi} \cdot \hat{z} &= 0 \end{aligned}$$

Substituting for the components of \vec{B}_L and \vec{B}_0 , one has in rectangular coordinates:

$$N_z = -\frac{2M}{3} \sum_{k=-1}^1 \sum_{\ell=1}^{\infty} \sum_{m=-\ell}^{\ell} i m \alpha_{\ell m} R^{\ell-1} \left(\frac{2\ell+1}{\ell+1} \right) Y_{1k}^*(\Omega, \phi_0) \int d\Omega' Y_{1k}(\theta, \phi) Y_{\ell m}(\theta, \phi)$$

$$N_z = M i \sqrt{\frac{3}{8\pi}} \sin \Omega (\alpha_{11} - \alpha_{11}^*) \quad \text{for } \phi_0 = 0 ;$$

$$\begin{aligned} N_x &= -\frac{2M}{3} \sum_k \sum_{\ell} \sum_m R^{\ell-1} \left(\frac{2\ell+1}{\ell+1} \right) \alpha_{\ell m} Y_{1k}^*(\Omega, \phi_0) \left(i m \int d\Omega' \frac{\cos\theta \cos\phi}{\sin\theta} Y_{1k} Y_{\ell m} \right. \\ &\quad \left. + \int d\Omega' \sin\phi Y_{1k} \frac{\partial}{\partial\theta} Y_{\ell m} \right) \end{aligned}$$

$$N_x = M i \sqrt{\frac{3}{8\pi}} \cos \Omega (\alpha_{11}^* - \alpha_{11}) \quad \text{for } \phi_0 = 0 ;$$

$$N_y = \frac{2M}{3} \sum_k \sum_\ell \sum_m R^{\ell-1} \left(\frac{2\ell+1}{\ell+1} \right) \alpha_{\ell m} Y_{1k}^*(\Omega, \phi_0) \left(i m \int d\Omega' \frac{\cos\theta \cos\phi}{\sin\theta} Y_{1k} Y_{\ell m} - \int d\Omega' \cos\phi Y_{1k} \frac{\partial}{\partial\phi} Y_{\ell m} \right) ,$$

$$N_y = M \sqrt{\frac{3}{8\pi}} \cos \Omega (\alpha_{11} + \alpha_{11}^*) + M \alpha_{10} \sqrt{\frac{3}{4\pi}} \sin \Omega \quad \text{for } \phi_0 = 0 .$$

Using this general result the previous calculation can be verified. For a uniform applied field,

$$\Phi_0 = -B_0 \sqrt{\frac{4\pi}{3}} \left(r + \frac{R^3}{2r^2} \right) Y_{10}(\theta, \phi)$$

so that $\alpha_{10} = -B_0 \sqrt{\frac{4\pi}{3}}$ and $\alpha_{\ell m} = 0$ for $\ell \neq 1, m \neq 0$. Then

$$N_x = 0 ,$$

$$N_y = -M B_0 \sin \Omega ,$$

$$N_z = 0 ,$$

as before.

One additional point should be mentioned. Because a superconductor is diamagnetic, it experiences a force when immersed in a nonuniform magnetic field. This force can cause a torque if the center of support is not the center of mass. Using the boundary condition $\vec{B} \cdot \hat{n} = 0$ at the surface, the force on a superconducting sphere in an arbitrary magnetic field has been calculated by Harding [13].

C. The Infinite Superconducting Plane

Assume that the half-space defined by the equation $x < 0$ is occupied by a semi-infinite superconducting slab and that there are no other superconductors in the half-space $x > 0$. One asks for the induction \vec{B} due to the infinite superconducting plane and an arbitrary current distribution in the region $x > 0$.

Since the boundary condition is $\vec{B} \cdot \hat{n} = B_x = 0$ at $x = 0$ and since there are no other superconductors present, this problem is a simple image problem. The solution is found by replacing the superconductor by the image of the current distribution mirrored in the y - z plane. The solution for \vec{B} in the region $x > 0$ is then the superposition of the fields due to the original current distribution and the image current distribution.

D. Torque due to a Current in the Readout Loop

Choose a coordinate system with the origin at the center of the sphere and with z -axis perpendicular to the plane containing the readout loop. The center of the sphere is assumed to lie in this plane. Let the radius of the readout loop be $R + \epsilon$, where R is the radius of the superconducting sphere. The loop itself is assumed to have negligible cross section so that the current density of the loop is

$$\vec{J} = \frac{I \delta(\cos\theta) \delta(r - R - \epsilon)}{R} \hat{\phi},$$

where I is the current in the readout loop and $\delta(x)$ is the Dirac delta function.

Assume for the moment that the rotor is stationary. Shielding currents flow in the rotor to exclude the field of the current loop. In the limit of tight coupling ($\epsilon \rightarrow 0$), the rotor appears locally to be an infinite superconducting plane. In other words, to have a perfect Meissner effect, the field of the supercurrent must cancel the field of the readout loop, so that in the limit $\epsilon \rightarrow 0$, the supercurrent density \vec{j}_0 is just

$$\vec{j}_0 \cong - \frac{I \delta(\cos\theta) \delta(r - R)}{R} \hat{\phi} = - \frac{I \delta(\cos\theta) \delta(r - R)}{R} [-\sin\phi \hat{x} + \cos\phi \hat{y}]$$

Appealing to the theorem, for the rotating sphere, one has

$$\begin{aligned} \vec{j} &\cong \vec{j}_L - \frac{I \delta(\cos\theta) \delta(r - R)}{R} [-\sin\phi \hat{x} + \cos\phi \hat{y}], \\ \vec{h} &\cong \vec{h}_L \end{aligned}$$

In the coordinate system with \hat{z}' parallel to $\vec{\omega}$ (see Figure 3), the London field has the form

$$\begin{aligned}\vec{h}_L(\vec{r}') &= \hat{r}' F(r') \cos\theta' + \hat{\theta}' G(r') \sin\theta' \\ &= \hat{x}' [F + G] \cos\theta' \sin\theta' \cos\phi' + \hat{y}' [F + G] \cos\theta' \sin\theta' \sin\phi' \\ &\quad + \hat{z}' \{ [F + G] \cos^2\theta' - G \}\end{aligned}$$

Denoting the angle between \hat{z} and \hat{z}' by Ω and choosing \hat{y} and \hat{y}' to coincide, the components of $\vec{h}_L(\vec{r}')$ can be rewritten in terms of the unprimed coordinates:

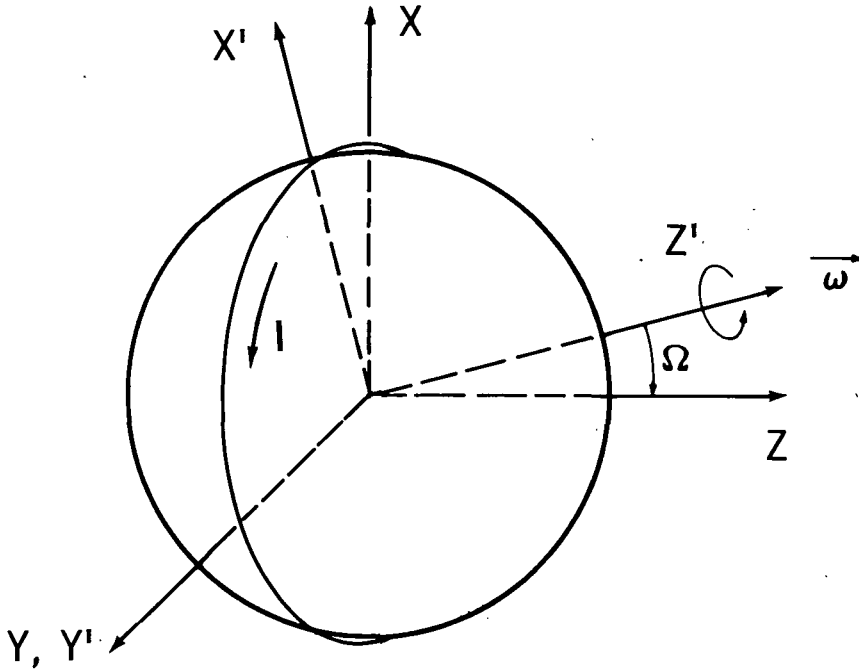

Figure 3. A current loop around the rotor. (The center of the sphere coincides with the center of the loop; the Y, Y' axes coincide and lie in the plane of the loop. The Z axis is perpendicular to the plane of the loop; the Z' axis lies along the spin axis of the rotor.)

$$\begin{aligned}
(h_L)_x &= [F + G] \cos\Omega (\sin\Omega \sin\theta \cos\phi + \cos\Omega \cos\theta)(\cos\Omega \sin\theta \cos\phi - \sin\Omega \cos\theta) \\
&\quad + [F + G] \sin\Omega (\sin\Omega \sin\theta \cos\phi + \cos\Omega \cos\theta)^2 - G \sin\Omega \quad ,
\end{aligned}$$

$$(h_L)_y = [F + G] \sin\theta \sin\phi (\sin\Omega \sin\theta \cos\phi + \cos\Omega \cos\theta) \quad ,$$

$$\begin{aligned}
(h_L)_z &= -[F + G] \sin\Omega (\sin\Omega \sin\theta \cos\phi + \cos\Omega \cos\theta)(\cos\Omega \sin\theta \cos\phi - \sin\Omega \cos\theta) \\
&\quad + [F + G] \cos\Omega (\sin\Omega \sin\theta \cos\phi + \cos\Omega \cos\theta)^2 - G \cos\Omega \quad .
\end{aligned}$$

The torque on the rotor is

$$\vec{N} = \frac{1}{c} \int d^3 r [\vec{r} \times (\vec{j} \times \vec{h})] = \frac{1}{c} \int d^3 r [\vec{r} \times (\vec{j}_0 \times \vec{h}_L)]$$

Substituting the expressions for \vec{j}_0 and \vec{h}_L into the above, carrying out the vector multiplication, and then integrating, one obtains the result

$$\vec{N} = -\hat{y} \frac{I}{c} \pi R^2 F(R) \sin\Omega$$

Now

$$F(R) = \frac{2m^*c\omega}{e^*} + \text{terms of order } \lambda/R \quad ,$$

so that to lowest order in λ/R the torque is

$$\boxed{\vec{N} = -\hat{y} \left(\frac{\pi R^2 I}{c} \right) \left(\frac{2m^*c}{e^*} \omega \right) \sin\Omega}$$

Thus to lowest order in λ/R , the torque is the same as that on a current loop of radius R in a uniform magnetic field equal to the London field. With $I = 0.5 \mu\text{A}$, $R = 2 \text{ cm}$, and $\omega = 400 \pi \text{ s}^{-1}$, the maximum torque is

$$N_{\text{max}} \sim 9 \times 10^{-8} \text{ N m}$$

E. Torque due to a Flat Region in the Superconducting Shield

A change in the gyro housing design was proposed in order to reduce difficulties in the precision machining of certain parts. However, the change in design necessitated departure from spherical symmetry for the superconducting magnetic shield, which would introduce extraneous torque on the rotor. In the new design, the superconducting shield would be spherical except for a flat spot of half angle θ_0 , as shown in Figure 4.

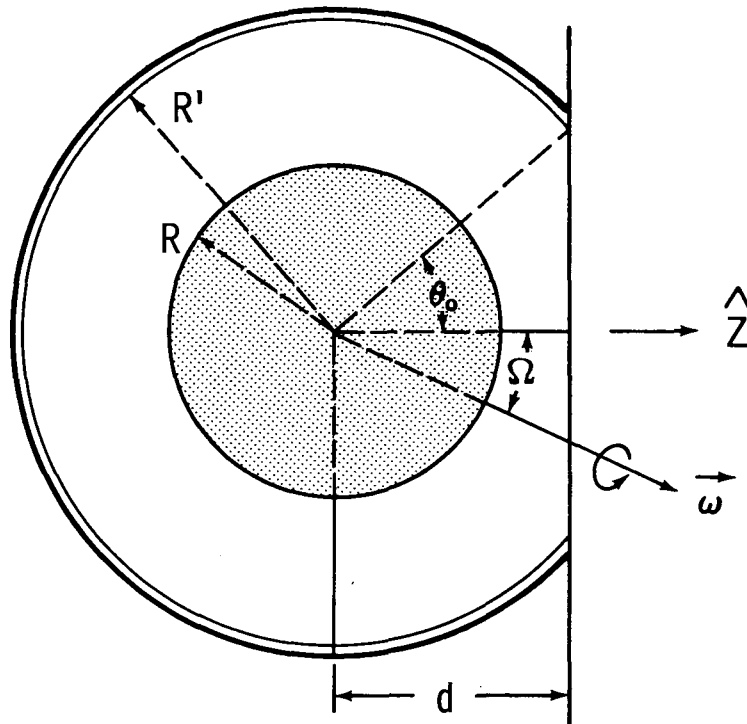

Figure 4. A proposed shield design. (The shield is spherical except for a flat spot which subtends a half-angle θ_0 at the center of the spherical portion. The spherical part of the shield is concentric with the rotor.)

The torque for this shield design with the spin axis at a small angle Ω with the respect to the axis of symmetry has been calculated by C. Ebner and C. C. Sung⁷. Their result is expressed in the form

$$N = C(\theta_0, R'/R) (m^*c\omega/e^*)^2 R^3 \sin\Omega$$

Here R is the ball radius and R' is the radius of the spherical section of the shield. (Actually the coefficient C depends on the angle Ω also, but is rather insensitive for small Ω .) Ebner and Sung provided numerical values of $C(\theta_0, R'/R)$ for $15^\circ < \theta_0 < 45^\circ$ and $1.5 < R'/R < 3.0$.

To get a better physical feeling for the problem and to gain insight into the above result, an approximate calculation for the limiting case of a large flat spot was carried out.

Since the London field falls off as a dipole outside the rotor, the currents in the flat part of the shield should fall off rapidly away from the center of the flat. Therefore for a large flat spot in a large shield ($R \ll R' \cos\theta_0 \ll R'$), the torque should be approximately that on a point dipole near an infinite superconducting plane (Fig. 5), a problem easily solved by image methods.

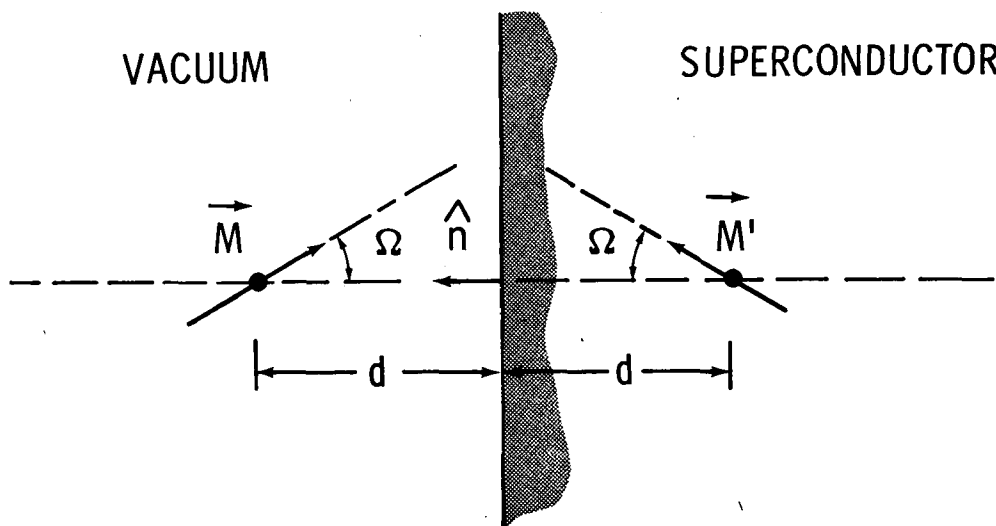

Figure 5. Image method for calculating torque due to the flat spot in the point dipole/infinite superconducting plane approximation.

7. Karr, G. R. and Hendricks, J. B.: Fourth Quarterly Progress Report, Contract NAS8-29316, Appendix I – Magnetic Shielding Calculations, by C. C. Sung and C. Ebner.

The torque is given by

$$\begin{aligned}
 \vec{N} &= \vec{M} \times \vec{B} \text{ (image dipole)} \\
 &= \vec{M} \times \left[\frac{3 \hat{n} (\vec{M}' \cdot \hat{n}) - \vec{M}'}{|\vec{r} - \vec{r}'|^3} \right] \\
 &= \frac{M^2}{8d^3} [3 \cos\Omega \sin(\pi - \Omega) - \sin(\pi - 2\Omega)] \hat{y} \\
 &= \frac{M^2}{16d^3} \sin 2\Omega \hat{y}
 \end{aligned}$$

where \hat{y} is a unit vector out of the page in Figure 5. Substituting $d = R' \cos\theta_0$ and $M = (m^*c\omega/e^*)R^3$ yields the approximation

$$N \cong (R/2R' \cos\theta_0)^3 (m^*c\omega/e^*)^2 \frac{R^3}{2} \sin 2\Omega$$

For $R = 1.9$ cm, $R' = 4.3$ cm, $\theta_0 = 57$ deg, and $\omega = 400\pi$ Hz, one has

$$N \cong 1.2 \times 10^{-16} \sin 2\Omega \text{ N m} ,$$

in good agreement with the Ebner-Sung result of $N \cong 1.6 \times 10^{-16} \sin\Omega$ N m for these values.

Since the actual rotor/shield arrangement has the same symmetry as the point dipole/infinite plane, it can be concluded that the torque will be zero for $\Omega = \pi/2$ as well as for $\Omega = 0$ and $\Omega = \pi$, a result not foreseen from the small angle result of Ebner and Sung. This observation is important because, after the Ebner-Sung calculation had been completed, the design was changed again; in the new configuration it is planned to have the spin axis such that $\Omega \approx \pi/2$ rather than $\Omega \approx 0$.

F. Discussion

As noted in the introduction, one of the design goals of the gyroscope relativity experiment is that the precession due to nonrelativistic torques be less than 1 ms of arc per year. This requires that the magnitude of the residual torque be less than 2×10^{-18} N m.

The preceding calculations show that to meet this objective, the superconducting shielding must be designed so as to reduce the magnetic field in the interior to approximately 10^{-7} gauss (10^{-11} tesla) or less, and the field due to trapped flux must be equally small. These restrictions were noted earlier by C.W.F. Everitt [14,15]. It should be possible to eliminate trapped flux by careful cooling in a sufficiently low field; with special techniques, field levels as low as 6×10^{-8} gauss have been obtained [16].

Since the magnetic flux through a hole in a superconductor cannot change, any magnetic field leaking through a hole in the superconducting shield surrounding the rotor will be strongly attenuated. A ballpark estimate can be obtained for leakage of magnetic field through a hole in a spherical shield from data for superconducting cylinders. For a cylinder of radius a , the axial field decreases as $B = B_0 \exp(-3.4 z/a)$ and the transverse field decreases as $B = B_0 \exp(-1.8 z/a)$, where z is measured from the end of the cylinder [17]. If one lets $z = R' - R$, the distance between rotor and shield, then for a transverse attenuation of 10^{-7} an estimate of $a \sim (R' - R)/9$ for the radius of the largest permissible hole is obtained. For $R' = 4.3$ cm and $R = 1.9$ cm, this gives $a_{\max} \sim 0.3$ cm. Since each hole attenuates more or less independently and since the torque calculation assumed a uniform field, the number of holes should not be critical. The exponential z -dependence above results from separation of variables in cylindrical coordinates and the vanishing of the normal component of \vec{B} at the inner cylinder wall; a different functional dependence for the variable r would certainly be expected for a hole in a spherical superconducting shell. Moreover, the attenuation should depend on the size of the hole relative to both the shield thickness and the shield radius, probably through multiplicative factors. Finally, holes remove spherical symmetry and, like the flat spot, produce a diamagnetic torque. Clearly a more precise calculation of the hole problem should be undertaken.

The torque due to the flat spot will depend on the pointing accuracy. For $\Omega = 0 + \delta\Omega$ (or $\Omega = \frac{\pi}{2} + \delta\Omega$), one has for $\theta_0 = 57$ deg: $N \approx 2.8 \times 10^{-18}$ N m for $\delta\Omega = 1$ deg, $N \approx 4.7 \times 10^{-20}$ N m for $\delta\Omega = 1$ min, and $N \approx 7.8 \times 10^{-22}$ N m for $\delta\Omega = 1$ s. Thus for a pointing error of less than 1 min of arc, the torque due to the flat spot will be completely negligible.

8. Hendricks, J. B.: A SQUID Readout System for a Superconducting Gyroscope. 1974 Applied Superconductivity Conference, Sept. 30-Oct. 2, 1974, Oakbrook, Ill. (Proc. to be published).

The magnitude of the torque due to a current in the readout loop is mildly disturbing. In the direct SQUID configuration⁸, a dc current as large as that corresponding to half a flux unit ($\Phi_0 = 2.07 \times 10^{-15}$ weber) can exist in the loop. For a SQUID inductance of 1.5×10^{-9} henry, this current could be as large as 6.9×10^{-7} A, with a corresponding torque of 1.2×10^{-17} N m. However, a slow roll of the spacecraft about the optical axis of the telescope is planned. If the spin axis of the gyro coincides with the optical axis of the telescope, the average torque due to a current in the read-out loop will be zero.

George C. Marshall Space Flight Center
National Aeronautics and Space Administration
Marshall Space Flight Center, Alabama, February 1975
188-78-51-0000-59-00-300