

General Disclaimer

One or more of the Following Statements may affect this Document

- This document has been reproduced from the best copy furnished by the organizational source. It is being released in the interest of making available as much information as possible.
- This document may contain data, which exceeds the sheet parameters. It was furnished in this condition by the organizational source and is the best copy available.
- This document may contain tone-on-tone or color graphs, charts and/or pictures, which have been reproduced in black and white.
- This document is paginated as submitted by the original source.
- Portions of this document are not fully legible due to the historical nature of some of the material. However, it is the best reproduction available from the original submission.

(NASA-CR-143880) STRUCTURAL EVALUATION OF
CANDIDATE DESIGNS FOR THE LARGE SPACE
TELESCOPE PRIMARY MIRROR Research Report, 1
Jan. - 1 Sep. 1974 (Draper (Charles Stark)
Lab., Inc.) 173 p HC \$6.25

N75-26416

CSCL 20K G3/39

Unclas
27310

R-874

STRUCTURAL EVALUATION OF CANDIDATE DESIGNS
FOR THE
LARGE SPACE TELESCOPE PRIMARY MIRROR

by

Keto Soosaar
Roland Grin

Martin Furey
Joseph Hamilton

April 1975

This report covers research conducted between
January 1, 1974 and September 1, 1974



The Charles Stark Draper Laboratory, Inc.

Cambridge, Massachusetts 02139



R-874

STRUCTURAL EVALUATION OF CANDIDATE DESIGNS FOR THE
LARGE SPACE TELESCOPE PRIMARY MIRROR



by

Keto Soosaar
Roland Grin
and
Martin Furey
Joseph Hamilton

April 1975

This report covers research conducted
between January 1, 1974 and September 1, 1974

Approved: 
N. Sears

W. Denhard

The Charles Stark Draper Laboratory, Inc.
Cambridge, Massachusetts 02139

ACKNOWLEDGMENT

The assistance of Dr. James Matthews with the fracture toughness studies is gratefully acknowledged.

This report was prepared under Project 55-52100 sponsored by Marshall Space Flight Center of the National Aeronautics and Space Administration through Contract NAS8-29187. The guidance and advice of Mr. Gwyn Faile and Mr. Charles Jones is most gratefully acknowledged.

The publication of this report does not constitute approval by the National Aeronautics and Space Administration of the findings or conclusions contained herein. It is published only for the exchange and stimulation of ideas.

Structural Evaluation of Candidate Designs for the
Large Space Telescope Primary Mirror

by

Roland Grin
Keto Soosaar

and

Martin Furey
Joseph Hamilton

ABSTRACT

Structural performance analyses have been conducted on two candidate designs for the NASA Large Space Telescope three-meter mirror. In a NASA Phase "B" competition the Itek Corp. and the Perkin-Elmer Corp. have each proposed a mirror using separate design configurations and different substrate materials. The mirror designs and the finite-element models used in the analyses evaluation are described. The results of the structural analyses for several different types of loading are presented in tabular and graphic forms.

Several additional analyses are also reported herein. These include the evaluation of a new mirror design concept proposed by the Boeing Co., a study of the global effects of local cell plate deflections, and an investigation of the fracture mechanics problems likely to occur with Cervit and ULE. Also, flexibility matrices were obtained for the Itek and Perkin-Elmer mirrors to be used in active figure control studies.

Summary, conclusions and recommendations complete the report.

TABLE OF CONTENTS

<u>Chapter</u>	<u>Page</u>
1. INTRODUCTION	1-1
2. INERTIAL LOAD EFFECTS ON THE ITEK AND PERKIN-ELMER PRIMARY MIRRORS	2-1
2.1 Description of Mirror Designs	2-1
2.2 Gravity Loads	2-1
2.3 Structural Models	2-3
2.4 Results of Analysis	2-3
2.4.1 1G Load Parallel to the Optical Axis (-Z)	2-3
2.4.2 1G Loads in The Lateral (+X and +Y) Directions	2-4
2.4.3 Remarks on Units	2-4
3. COMPARISON OF THE ITEK AND PERKIN-ELMER MIRRORS UNDER THERMAL LOAD	3-1
3.1 Thermal Loads	3-1
3.2 Structural Models	3-1
3.3 Results of Analysis	3-2
4. ANALYSIS OF A MIRROR USING THE BOEING DESIGN CONCEPT	4-1
4.1 Description of Mirror Design	4-1
4.2 Gravity Load	4-2
4.3 Structural Model	4-2
4.4 Results of Analysis	4-2
5. ADDITIONAL STUDIES	5-1
5.1 Study to Determine The Effect of Cell Plate Deflection	5-1
5.2 Fracture Toughness in Cervit and ULE	5-2
5.3 Flexibility Matrices for The Itek and Perkin-Elmer Mirrors for Use in The Study of Active Figure Control	5-4
6. SUMMARY, CONCLUSIONS AND RECOMMENDATIONS	6-1
APPENDIX A ILLUSTRATIONS OF OPTICAL SURFACE CONTOUR CHANGES	A-1
APPENDIX B FLEXIBILITY MATRICES	B-1
Bibliography	C-1

LIST OF ILLUSTRATIONS

<u>Figure</u>		<u>Page</u>
2.1	Itek 60° Finite Element Model	2-7
2.2	Perkin-Elmer Finite Element Model	2-8
2.3	Itek 360° Finite Element Model	2-9
2.4	Perkin-Elmer 360° Finite Element Model	2-10
2.5	Supports for the Itek 360° Model	2-11
2.6	Supports for the Perkin-Elmer 360° Model	2-11
2.7	Maximum Stresses, Front Plate of Itek Mirror	2-12
2.8	Maximum Stresses, Back Plate of Itek Mirror	2-13
2.9	Maximum Stresses, Front Plate of Perkin-Elmer Mirror	2-14
2.10	Maximum Stresses, Back plate of Perkin-Elmer Mirror	2-15
2.11	Deflection of Itek Mirror, 1G Load in X Direction	2-16
2.12	Deflection of Itek Mirror, 1G Load in Y Direction	2-16
2.13	Stresses Front Plate of Itek Mirror, 1G Load in X Direction	2-17
2.14	Stresses Front Plate of Itek Mirror, 1G Load in Y Direction	2-18
2.15	Stresses Rear Plate of Itek Mirror 1G Load in X Direction	2-19
2.16	Stresses Rear Plate of Itek Mirror 1G Load in Y Direction	2-20
2.17	Stresses Front Plate of Perkin-Elmer Mirror 1G Load in X Direction	2-21

LIST OF ILLUSTRATIONS (Continued)

<u>Figure</u>		<u>Page</u>
2.18	Stresses Front Plate of Perkin-Elmer Mirror 1G Load in Y Direction	2-22
2.19	Stresses Rear Plate of Perkin-Elmer Mirror 1G Load in X Direction	2-23
2.20	Stresses Rear Plate of Perkin-Elmer Mirror 1G Load in Y Direction	2-24
3.1	Radial Variation of Thermal Expansion Coefficient α , Perkin-Elmer Mirror	3-4
3.2	Variation of Thermal Expansion Coefficient α with Temperature, Itek Mirror	3-5
3.3	Probable Distribution of the Thermal Expansion Coefficient α in ULE Mirror	3-6
4.1	Boeing Concept Mirror, Finite Element Model of the Optical Surface	4-5
4.2	Boeing Concept Mirror, Stresses in the Top Plate	4-6
4.3	Boeing Concept Mirror, Stresses in the Bottom Plate	4-7
4.4	Boeing Concept Mirror, Stresses in the Core Webs	4-8
5.1	Critical Stress Intensity Factors	5-5
5.2	Applied Shear Loading vs Critical Crack Length	5-6
5.3	Fracture Probability of ULE Corning 7971, Abraded	5-7
5.4	Flaw Density vs Stress	5-8

LIST OF ILLUSTRATIONS (Continued)

<u>Figure</u>		<u>Page</u>
A.1	Z-Deflection Contours of the Itek Mirror Optical Surface, 1g Load (-Z Direction)	A-2
A.2	Z-Deflection Contours of the Perkin-Elmer Mirror Optical Surface, 1g Load (-Z Direction)	A-3
A.3	Z-Deflection Contours of the Itek Mirror Optical Surface, 1°F Soak, Nominal Thermal Coefficient	A-4
A.4	Z-Deflection Contours of the Itek Mirror Optical Surface, 1°F Axial Gradient, Nominal Thermal Coefficient	A-5
A.5	Z-Deflection Contours of the Itek Mirror Optical Surface, 1°F Radial Gradient, Nominal Thermal Coefficient	A-6
A.6	Z-Deflection Contours of the Itek Mirror Optical Surface, 1°F Soak, Thermal Coefficeint @ 10°C	A-7
A.7	Z-Deflection Contours of the Itek Mirror Optical Surface, 1°F Axial Gradient, Thermal Coefficient @ 10°C	A-8
A.8	Z-Deflection Contours of the Itek Mirror Optical Surface, 1°F Radial Gradient, Thermal Coefficient @ 10°C	A-9
A.9	Z-Deflection Contours of the Itek Mirror Optical Surface, 1°F Soak, Thermal Coefficeint @ 15°C	A-10
A.10	Z-Deflection Contours of the Itek Mirror Optical Surface, 1°F Axial Gradient, Thermal Coefficient @ 15°C	A-11
A.11	Z-Deflection Contours of the Itek Mirror Optical Surface, 1°F Radial Gradient, Thermal Coefficient @ 15°C	A-12

LIST OF ILLUSTRATIONS (Continued)

<u>Figure</u>		<u>Page</u>
A.12	Z-Deflection Contours of the Itek Mirror Optical Surface, 1°F Soak, Thermal Coefficient @ 20°C	A-13
A.13	Z-Deflection Contours of the Itek Mirror Optical Surface, 1°F Axial Gradient, Thermal Coefficient @ 20°C	A-14
A.14	Z-Deflection Contours of the Itek Mirror Optical Surface, 1°F Radial Gradient, Thermal Coefficient @ 20°C	A-15
A.15	Z-Deflection Contours of the Perkin-Elmer Mirror Optical Surface, 1°F Soak, Nominal Thermal Coefficient	A-16
A.16	Z-Deflection Contours of the Perkin-Elmer Mirror Optical Surface, 1°F Axial Gradient, Nominal Thermal Coefficient	A-17
A.17	Z-Deflection Contours of the Perkin-Elmer Mirror Optical Surface, 1°F Radial Gradient, Nominal Thermal Coefficient	A-18
A.18	Z-Deflection Contours of the Perkin-Elmer Mirror Optical Surface, 1°F Soak, Variable Thermal Coefficient	A-19
A.19	Z-Deflection Contours of the Perkin-Elmer Mirror Optical Surface, 1°F Axial Gradient, Variable Thermal Coefficient	A-20
A.20	Z-Deflection Contours of the Perkin-Elmer Mirror Optical Surface, 1°F Radial Gradient, Variable Thermal Coefficient	A-21
A.21	Z-Deflection Contours of the Boeing Mirror Optical Surface, 1g Transverse (-Z Direction)	A-22

LIST OF TABLES

<u>Table</u>		<u>Page</u>
2.1	Properties of the Itek and Perkin-Elmer Primary Mirrors	2-2
2.2	Comparison of Deflections, Itek vs Perkin-Elmer Mirror, 1g Load in the -Z Direction	2-5
2.3	Displacement at Mounts, Perkin-Elmer Mirror, 1g Load in the +X Direction	2-6
2.4	Displacement at Mounts, Perkin-Elmer Mirror, 1g Load in the +Y Direction	2-6
3.1	Distribution of " α " in Cervit Extreme Values	3-2
3.2	Maximum Deflections of Itek and Perkin-Elmer Mirror Surfaces Under Thermal Loads	3-3
4.1	Properties of Boeing Mirror	4-1
4.2	Comparison of Displacements with Various Phase A Design Concepts and the Boeing Concept	4-4
5.1	Comparison of Displacements, Itek Phase A "Exact" Mirror	5-1

Chapter 1

INTRODUCTION

This report documents structural analyses that were performed to help evaluate various "Phase B" designs for the primary mirror of the NASA Large Space Telescope.

Chapters 2 and 3 of the report discuss the two competing mirror designs, both of which were of lightweighted construction. The Itek Corp. design utilizes Owens-Illinois CERVIT material with a core lightweighted into hexagonally-shaped cells and a circumferential edge band. The Perkin-Elmer Corp. design uses Corning ULE, and is assembled with a core of square cells and a circumferential edge band. Both mirrors are compared under various inertial (Chapter 2) and thermal (Chapter 3) loads.

Chapters 4 and 5 contain additional miscellaneous investigations. Found here is the analysis of a CERVIT mirror to be constructed using an alternate simpler lightweighting technique proposed by the Boeing Co. Then a study is reported that was conducted to evaluate the additional effect of local cell deflections on the total mirror performance under 1G transversely applied. Finally some preliminary investigations are performed on the fracture mechanics problems associated with the use of CERVIT and ULE.

As an aid in the investigation of the active mirror figure control concept, unit loads representing actuators moving parallel to the optical axis are placed at a number of positions on the back surface of the mirror. The resulting deflection data is then used to generate the control matrices. This is discussed in Chapter 5 and the flexibility matrices are listed in Appendix B.

Chapter 2

INERTIAL LOAD EFFECTS ON THE ITEK AND PERKIN-ELMER PRIMARY MIRRORS

2.1 Description of Mirror Designs

The properties of the Itek and Perkin-Elmer primary mirrors are listed in Table 2.1. Each mirror is made of a "glassy" low thermal expansion material and is of a composite sandwich construction. The Itek mirror is machined from a solid blank of CERVIT and has a core lightweighted with hexagonally-shaped cells. It has a circumferential edge band at both the inside and outside diameters.

The Perkin-Elmer mirror is assembled from ULE plates fused together with a lightweighted core of square-shaped cells, and continuous circumferential and internal edge bands. Both mirrors are held at their outside edge at supports 120° apart which allow expansion in the radial direction. The Itek mirror is supported at a cylindrical trunnion at the mid-height of the outside edge band in a solid area and the Perkin-Elmer mirror is supported axially at the intersection of the back plate with the outside edge and tangentially at mid-height. Both support areas are considerably reinforced.

2.2 Inertial Loads

IG loads are applied individually in the direction of each of the three principal axes; that is, parallel to the optical axis (-Z direction) and along the X and Y axes which are parallel to the plane of the mirror. While all

PROPERTIES	ITEK	PERKIN-ELMER
Outside Diameter	3.05m (120 in.)	3.05m (120 in.)
Inside Hole Diameter	.813m (32 in.)	.635m (25 in.)
Spherical Radius of Curvature	14.4m (566.9 in.)	14.68m (578 in.)
Radial Thickness	.381m (15 in.)	.381m (15 in.)
Cell Shape	Hexagonal	Square
Cell Pitch	.122m (4.8 in.)	.102m (4.0 in.)
Top Plate Thickness	2.54cm (1.0 in.)	3.81cm (1.5 in.)
Bottom Plate Thickness	3.02cm (1.19 in.)	3.81cm (1.5 in.)
Bottom Plate Hole Diameter	8.255cm (3.25 in.)	None
Edge Band Thickness	1.016cm (.40 in.)	.635cm (.25 in.)
Cell Wall Thickness	.508cm (.20 in.)	.508cm (.20 in.)
Percent Light Weighting	91.6%	90%
Total Weight Mirror	1847kg (4071#)	1723kg (3800#)
Material	CERVIT	ULE
Density	2491 Kg/m ³ (.09 lb/in. ³)	2214 Kg/m ³ (.08 lb/in. ³)
E (Young's Modulus)	9.24 x 10 ¹⁰ N/m ² (13.4 x 10 ⁶ PSI)	6.76 x 10 ¹⁰ N/m ² (9.8 x 10 ⁶ PSI)
Poisson Ratio	.252	.170
Nominal Temperature Coefficient	.05 cm/cm/°C x 10 ⁻⁶ (.277 x 10 ⁻⁷ in/in/°F)	.03 cm/cm/°C x 10 ⁻⁶ (.167 x 10 ⁻⁷ in/in/°F)

Table 2.1 Properties of the Itek and Perkin-Elmer Primary Mirrors

three loading directions are important in evaluating dynamic effects, the optical axis direction is most significant in the manufacturing and, hence, the zero-g release problem. The response along the X and Y axes is important in launch evaluation.

2.3 Structural Models

Since the time available to evaluate the competing Phase B designs was limited to about seven weeks, the modeling was necessarily approximate, and the "Trade-off Model," as described in Ref. 1,* had to be used. Within this type, two sizes of finite element models were used. In analyzing for a 1G load parallel to the optical axis (-Z direction) a 60° segment was modeled. Roller supports were provided along the radial edges. In the analysis for the 1G loads perpendicular to the optical axes (X and Y directions) the entire mirror was modeled. The Itek 60° model is shown in Figure 2.1 and the full 360° model in Figure 2.3. The Perkin-Elmer 60° model is shown in Figure 2.2 and the full 360° model is shown in Figure 2.4. The supports at the circumference for the 360° models are shown in Figures 2.5 and 2.6. The mirror lightweighted cores were idealized as a solid continuum and were modeled using isoparametric 3D solid finite elements. The top and bottom plates and circumferential edge bands were modeled using plate elements. ICES-STRUDL II was used for all finite element computations.

2.4 Results of Analyses

2.4.1 1G Load Parallel to The Optical Axis (-Z)

A comparison of the deflections of the Itek versus

* See Bibliography

the Perkin-Elmer mirror under a 1G load parallel to the optical axis is given in Table 2.2. Z-contour deformations of the mirror top surfaces are shown in the Appendix in Figures A-1 and A-2. Maximum stresses at the front and back surfaces of the mirrors are shown in Figures 2.7 and 2.8 for the Itek mirror, and Figures 2.9 and 2.10 for the Perkin-Elmer mirror.

2.4.2 1G Loads in The Lateral (+X and +Y) Directions

The deformations shown in Figures 2.11 and 2.12 for the Itek mirror under 1G loads in the X and the Y directions are primarily rigid body displacements due to deflections in the mounts. The maximum stresses in the front plate of the mirror are shown in Figures 2.13 and 2.14, and in the rear plate in Figures 2.15 and 2.16.

The displacements at the mounts for the Perkin-Elmer mirror under a 1G load in the +X direction and a 1G load in the +Y direction are given in Tables 2.3 and 2.4. The coordinate system and the node numbers are shown in Figure 2.6. The maximum stresses in the front plate of the Perkin-Elmer mirror are given in Figures 2.17 and 2.18, and in the rear plate in Figures 2.19 and 2.20.

2.4.3 Remarks on Units

As all of the mirror drawings and material properties were provided to CSDL in the English system, the finite element modelling was performed using inches and pounds. It later developed that the optical surface displacements were desired in SI units. The results were then converted to that system, although for convenience, most of the summary tables use both sets of units. The "unit" thermal studies were performed with 1°F changes and gradients. These were not converted to °C changes since that can be readily performed when the actual temperatures are known, by inserting an additional factor of 1.8.

Designer	Material	Structural Type	Direction of 1G Gravity Load	Maximum Deflection Z-Direction 10^{-8} M (10^{-6} in)		
				Δ	Peak to Peak	RMS
ITEK	CERVIT	60° Segment equivalent solid core	-Z (transverse)	922 (363)	712 (281)	154 (61)
PERKIN-ELMER	ULE	60° Segment equivalent solid core	-Z (transverse)	1181 (465)	820 (323)	185 (73)

Table 2.2

Comparison of Deflections, Itek Vs. Perkin-Elmer Mirror, 1G Load in -Z Direction

DISPLACEMENT AT MOUNTS, PERKIN-ELMER MIRROR
1G LOAD IN THE +X DIRECTION

		Displ. $\times 10^{-8}$ M (10^{-6} in)		
Node #		ΔX	ΔY	ΔZ
Axial Mounts	129	+1821 (+717)	+200 (+79)	45.7 (+18)
	123	+1953 (+769)	-51 (-2)	-61 (-24)
	126	+1727 (+680)	-20.3 (-8)	+15.2 (+6)
Tangential Mounts	121	+1666 (+656)	+200 (+79)	-20.3 (-8)
	125	+1953 (+769)	0 (0)	-76.2 (-30)
	128	+1653 (+651)	-175 (-69)	+88.9 (+35)

Table 2.3

DISPLACEMENT AT MOUNTS, PERKIN-ELMER MIRROR
1G LOAD IN THE +Y DIRECTION

		Displ. $\times 10^{-8}$ M (10^{-6} in.)		
Node #		ΔX	ΔY	ΔZ
Axial Support	129	+88.9 (+33)	+1849 (+728)	+45.7 (+18)
	123	-122 (-48)	+1720 (+677)	+17.8 (+7)
	126	-127 (-50)	+1950 (+768)	-61 (-24)
Tangential Support	121	+173 (+68)	+1849 (+728)	+99.1 (+39)
	125	+5.1 (+2)	+1552 (+611)	-58.4 (-23)
	128	-175 (-69)	+1857 (+731)	-35.6 (-14)

Table 2.4

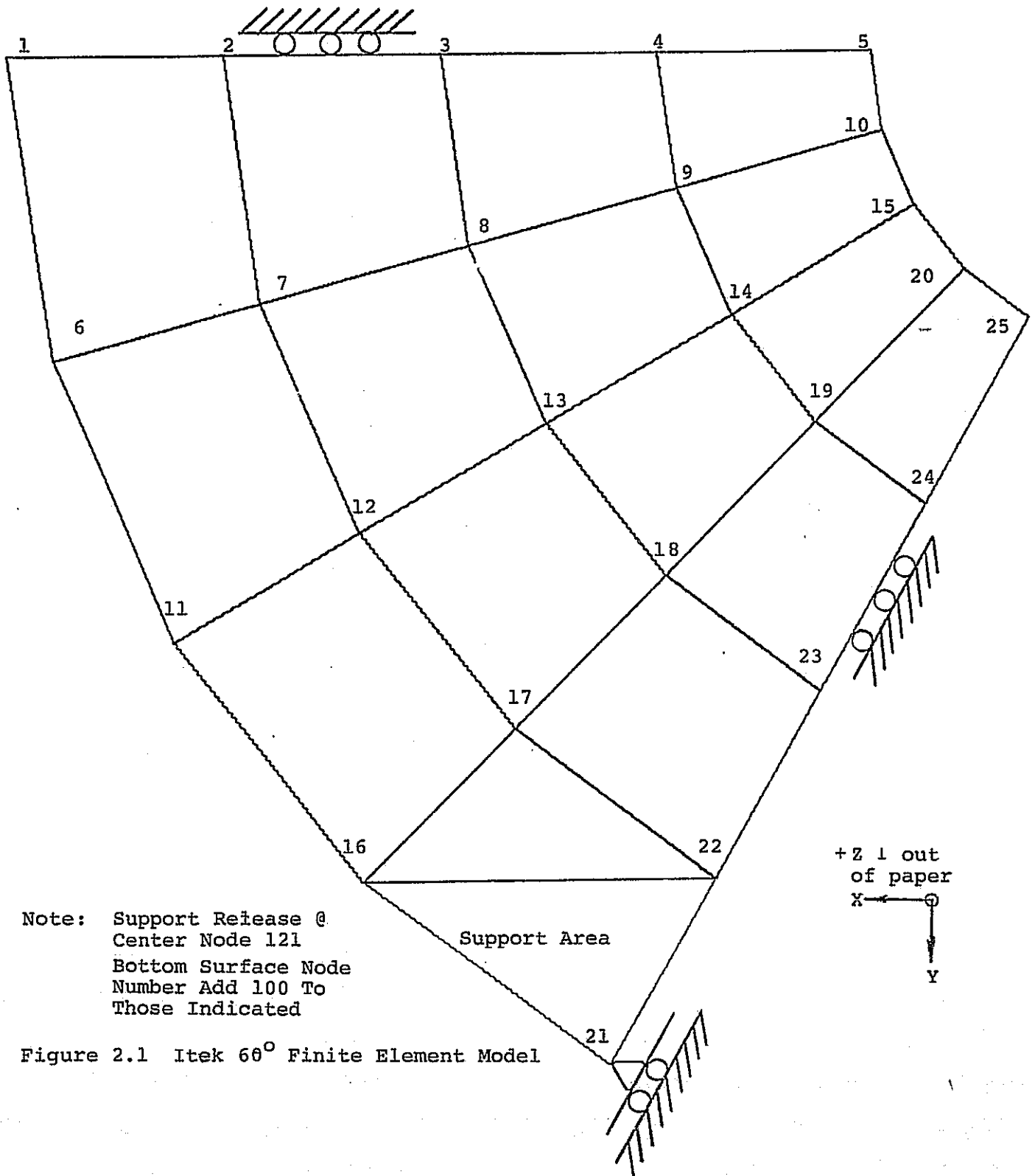

Note: Support Release @
 Center Node 121
 Bottom Surface Node
 Number Add 100 To
 Those Indicated

Figure 2.1 Itek 60° Finite Element Model

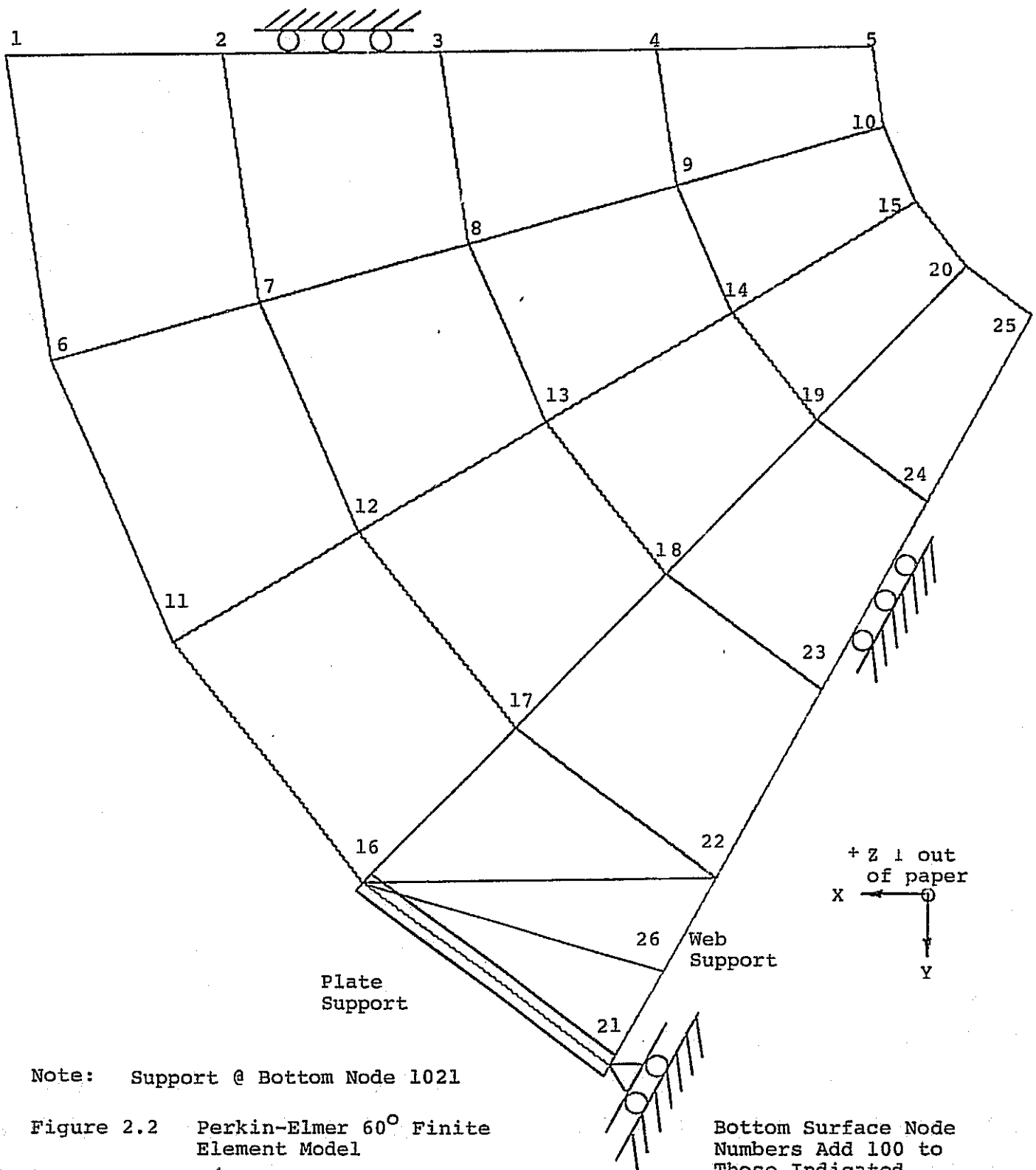

Note: Support @ Bottom Node 1021

Figure 2.2 Perkin-Elmer 60° Finite Element Model

Bottom Surface Node Numbers Add 100 to Those Indicated

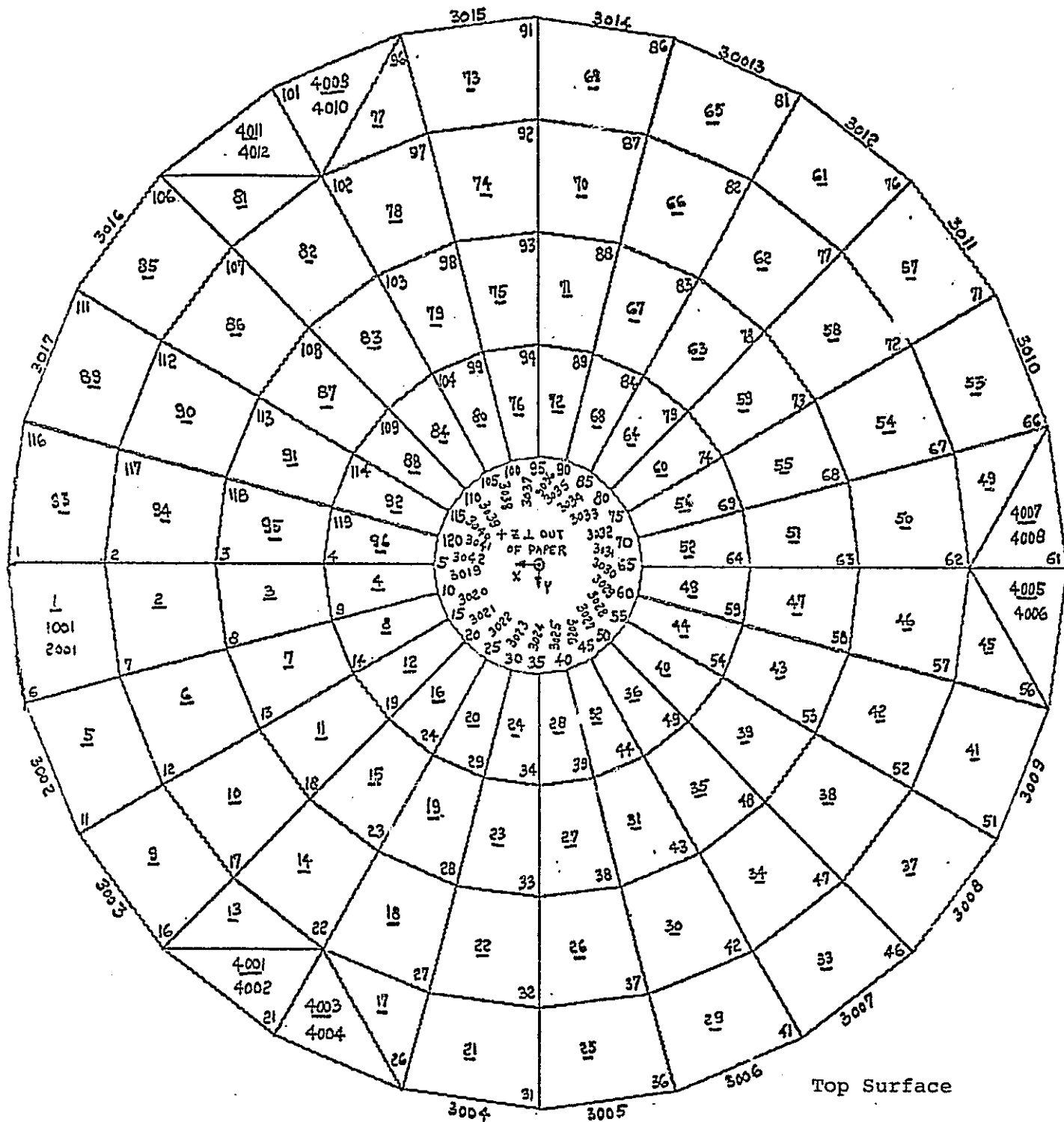

Figure 2.3 Itek 360° Finite Element Model

Bottom Surface Node
Numbers ADD 1000 To
Those Indicated

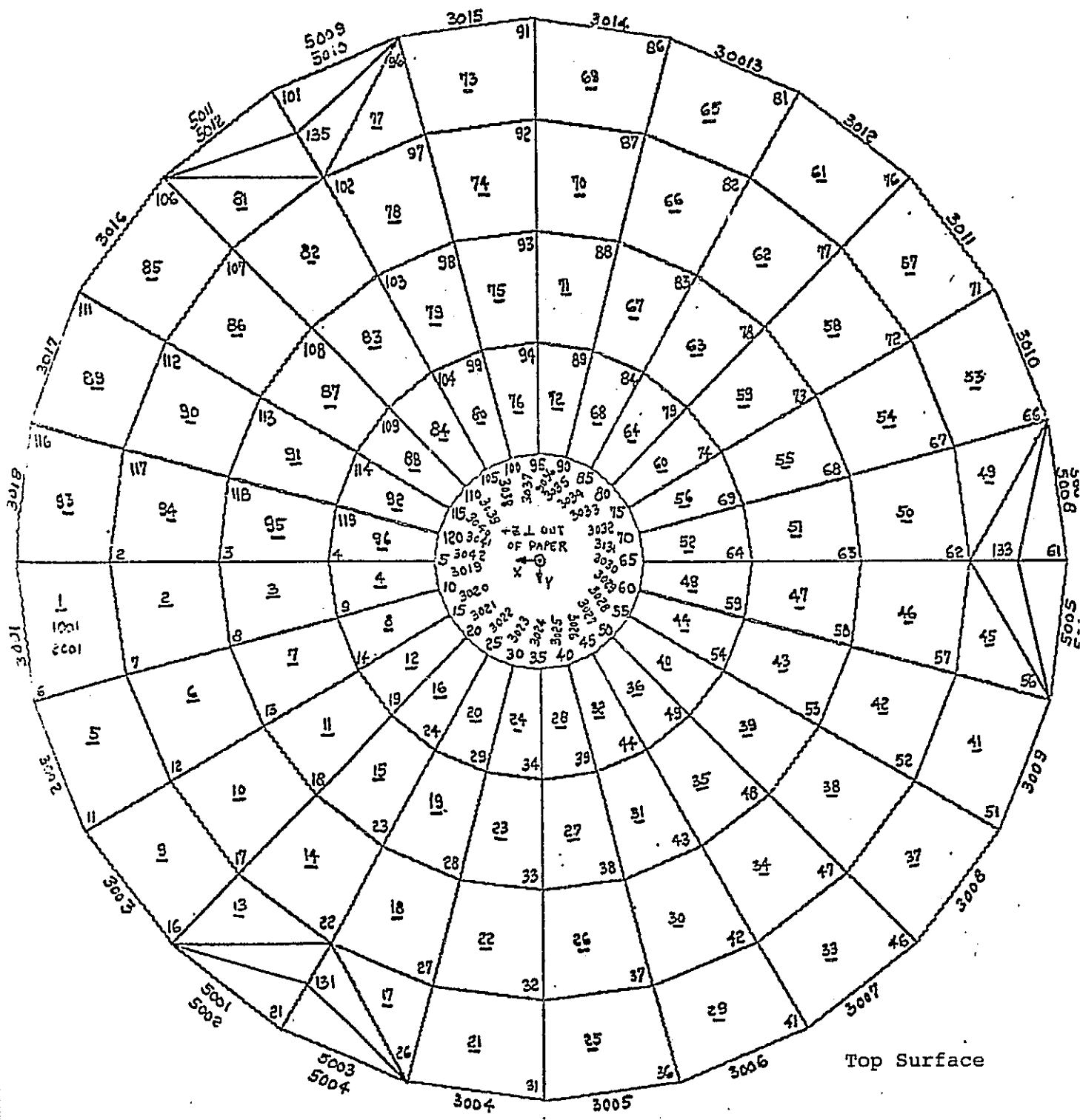

Figure 2.4 Perkin-Elmer 360° Finite Element Model

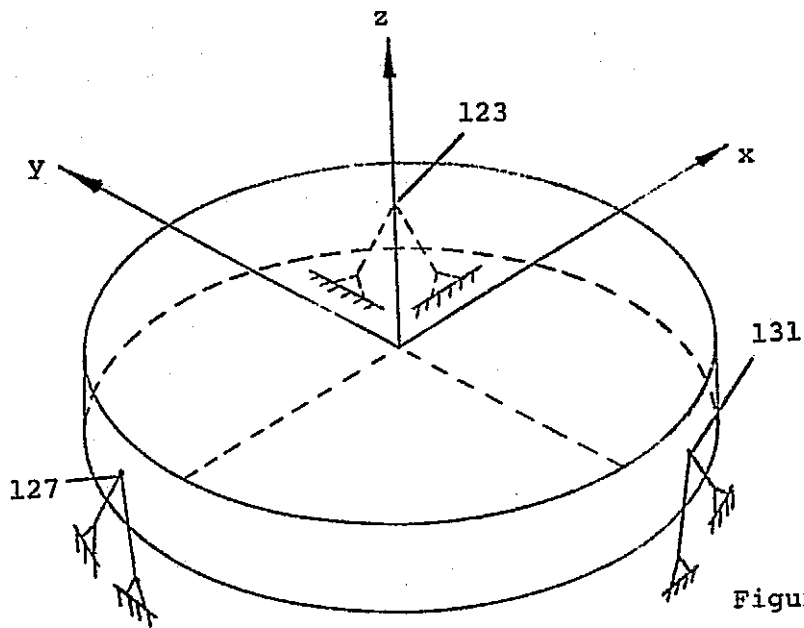

Figure 2.5
 Supports for the Itek
 360° Model

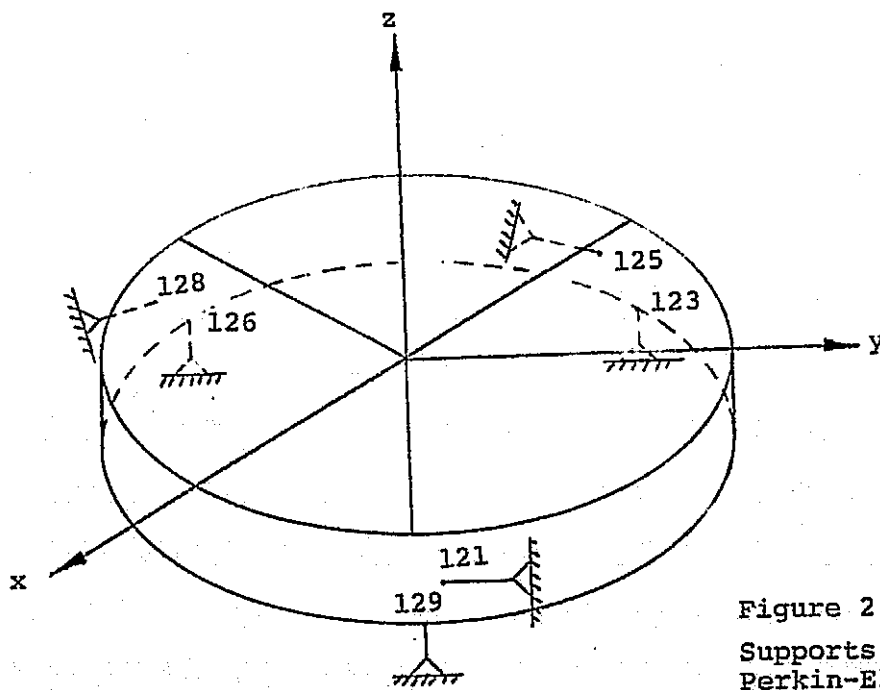

Figure 2.6
 Supports for the
 Perkin-Elmer 360° Model

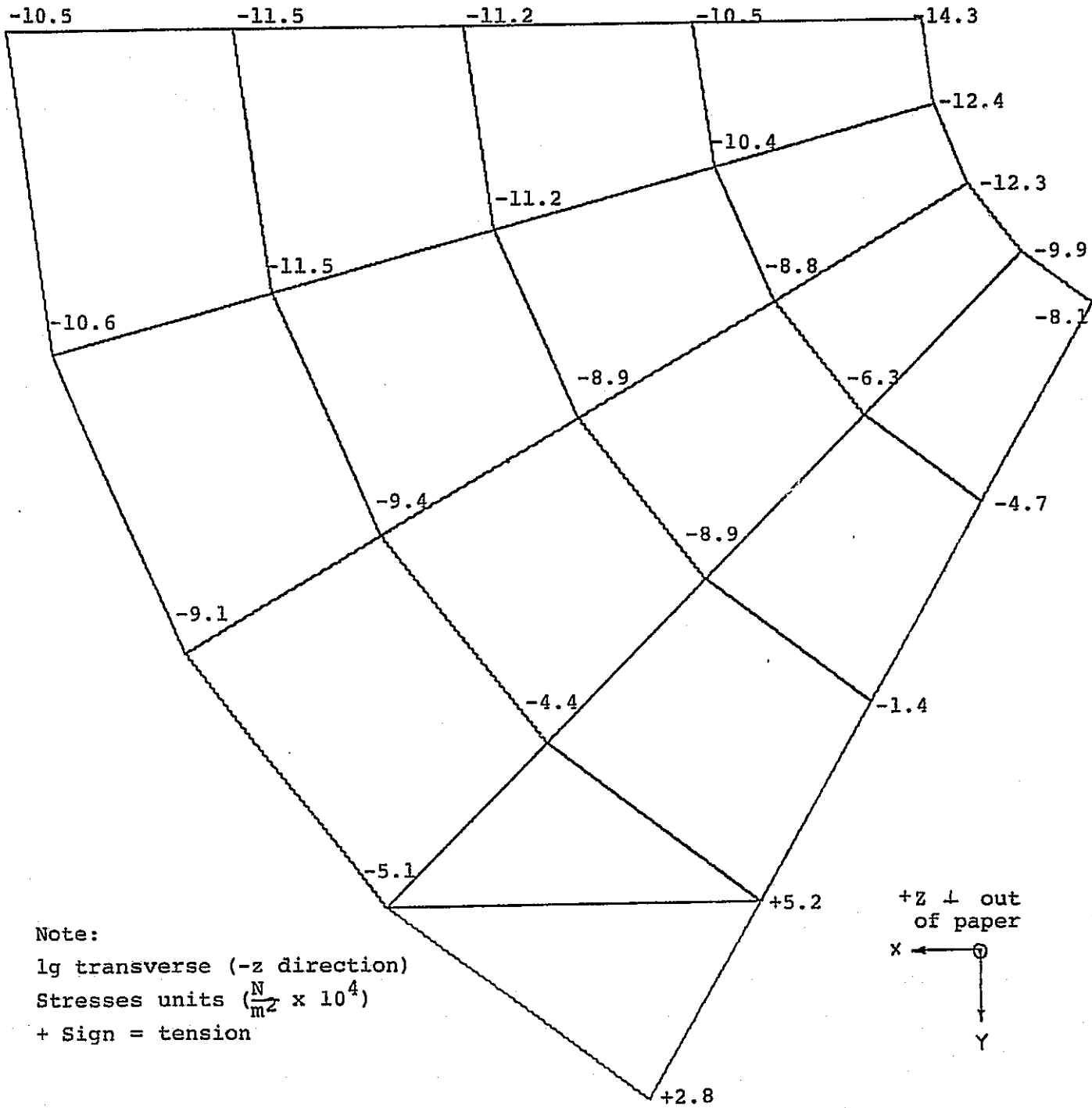

Figure 2.7 Maximum Stresses, Front Plate of Itek Mirror

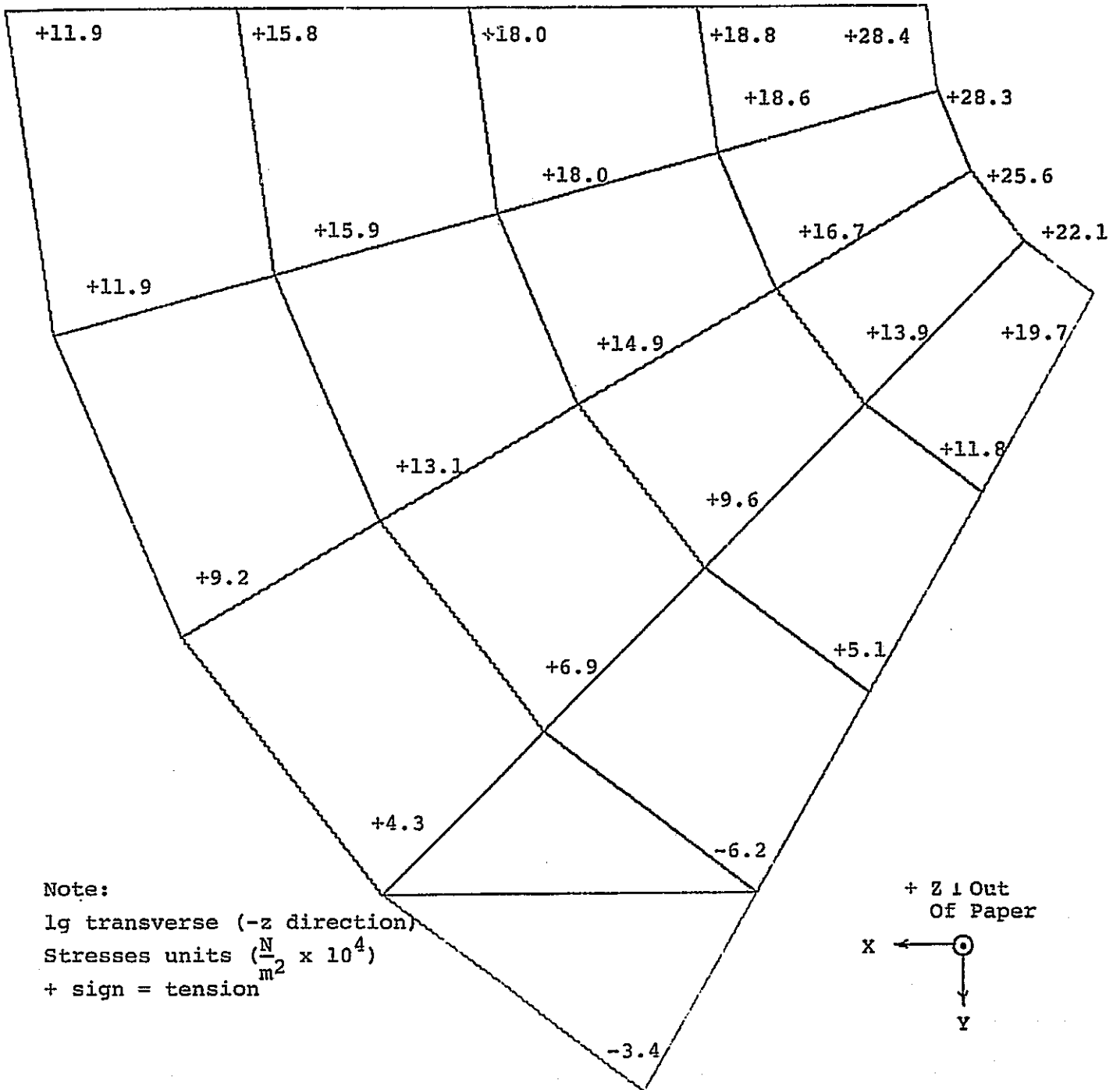

Figure 2.8 Maximum Stress, Back Plate of Itek Mirror

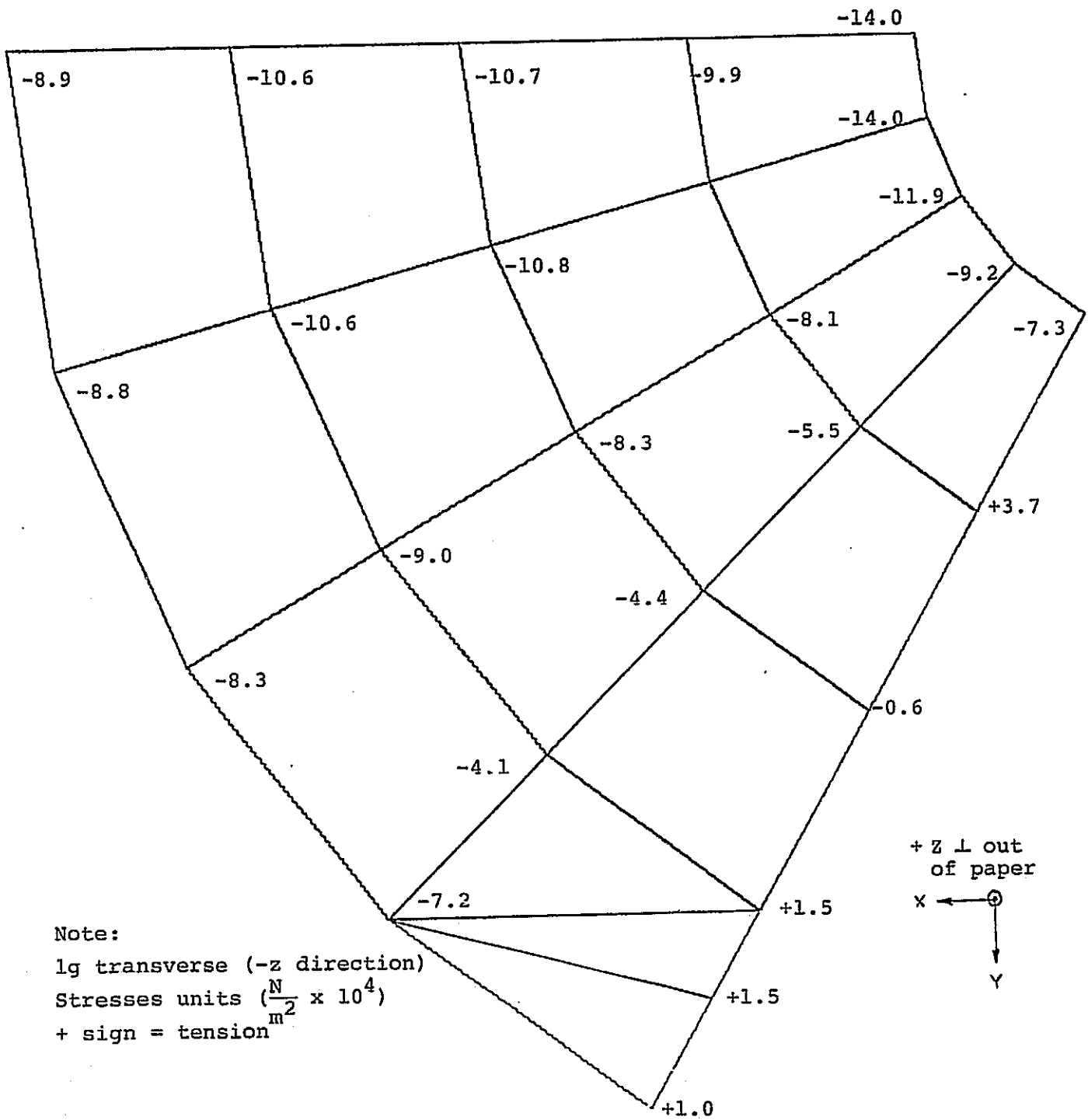

Figure 2.9 Maximum Stresses, Front Plate of Perkin-Elmer Mirror

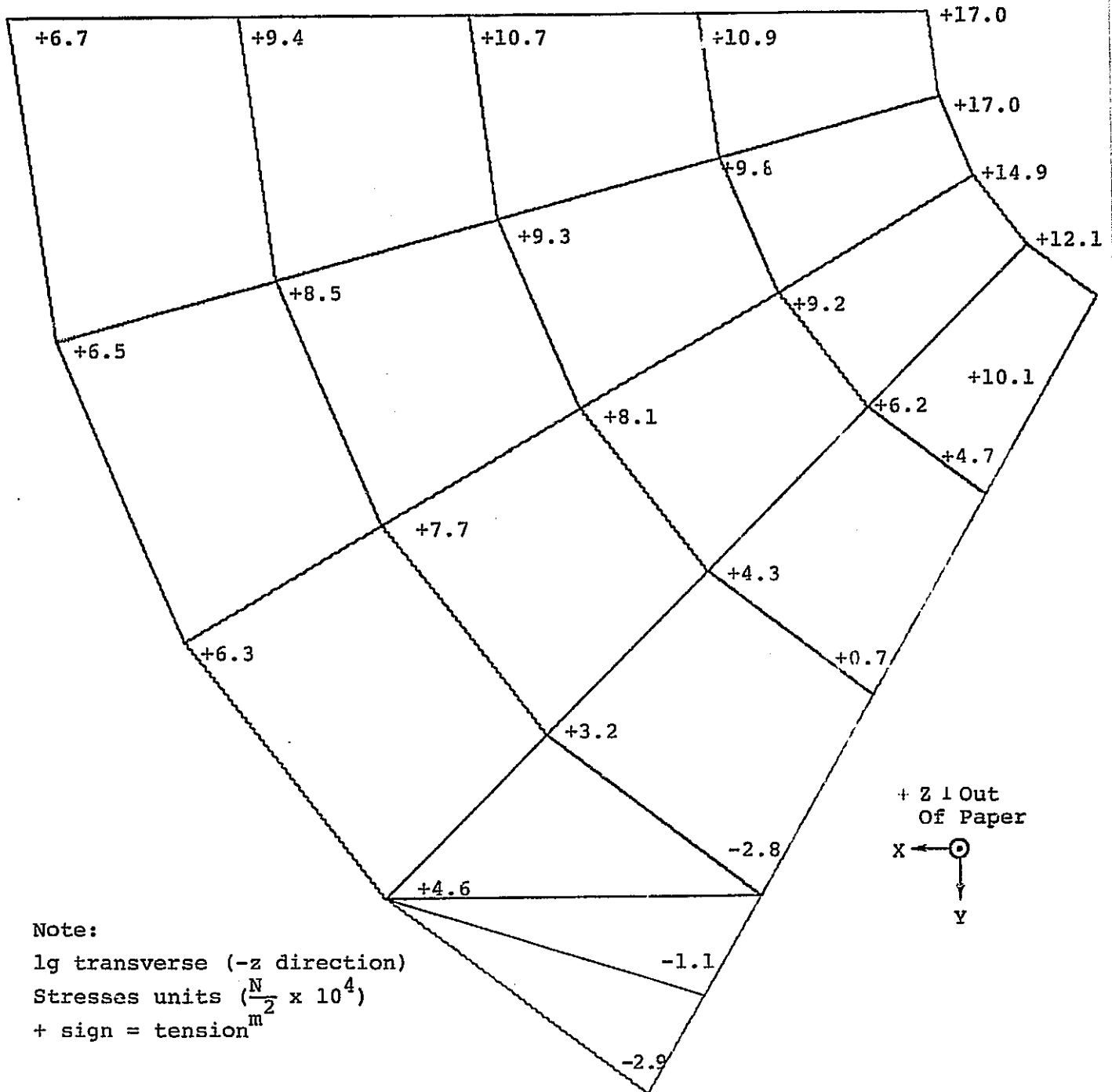

Figure 2.10 Maximum Stresses, Back Plate of Perkin-Elmer Mirror

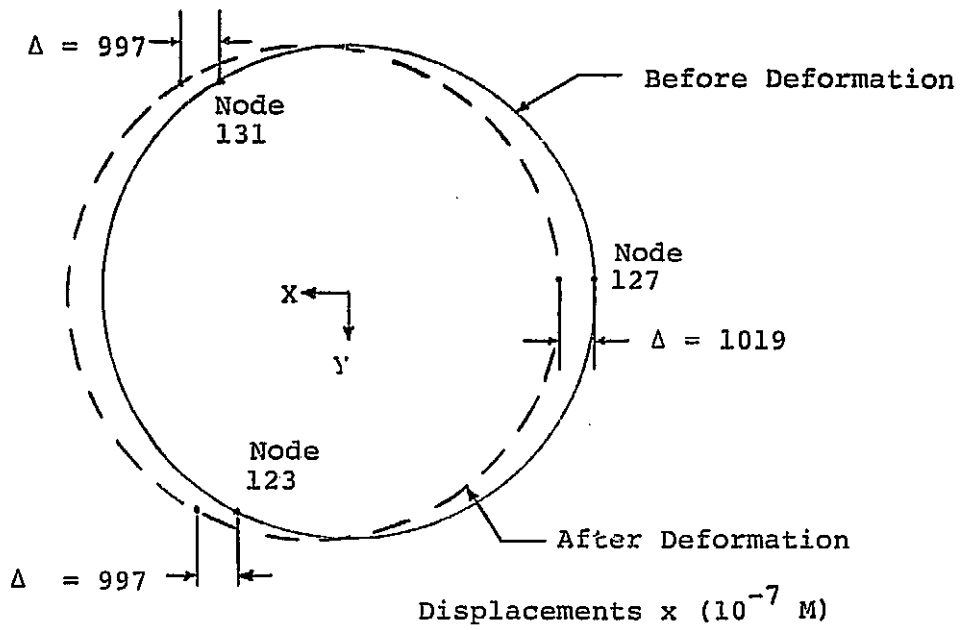

Figure 2.11 Deflection of Itek Mirror, lg Load in X Direction

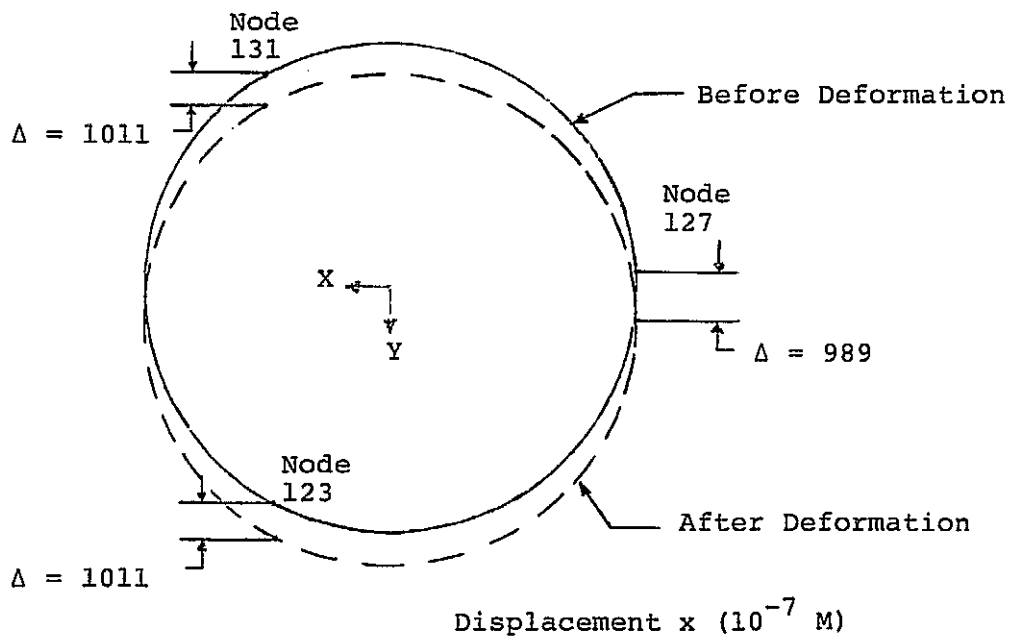
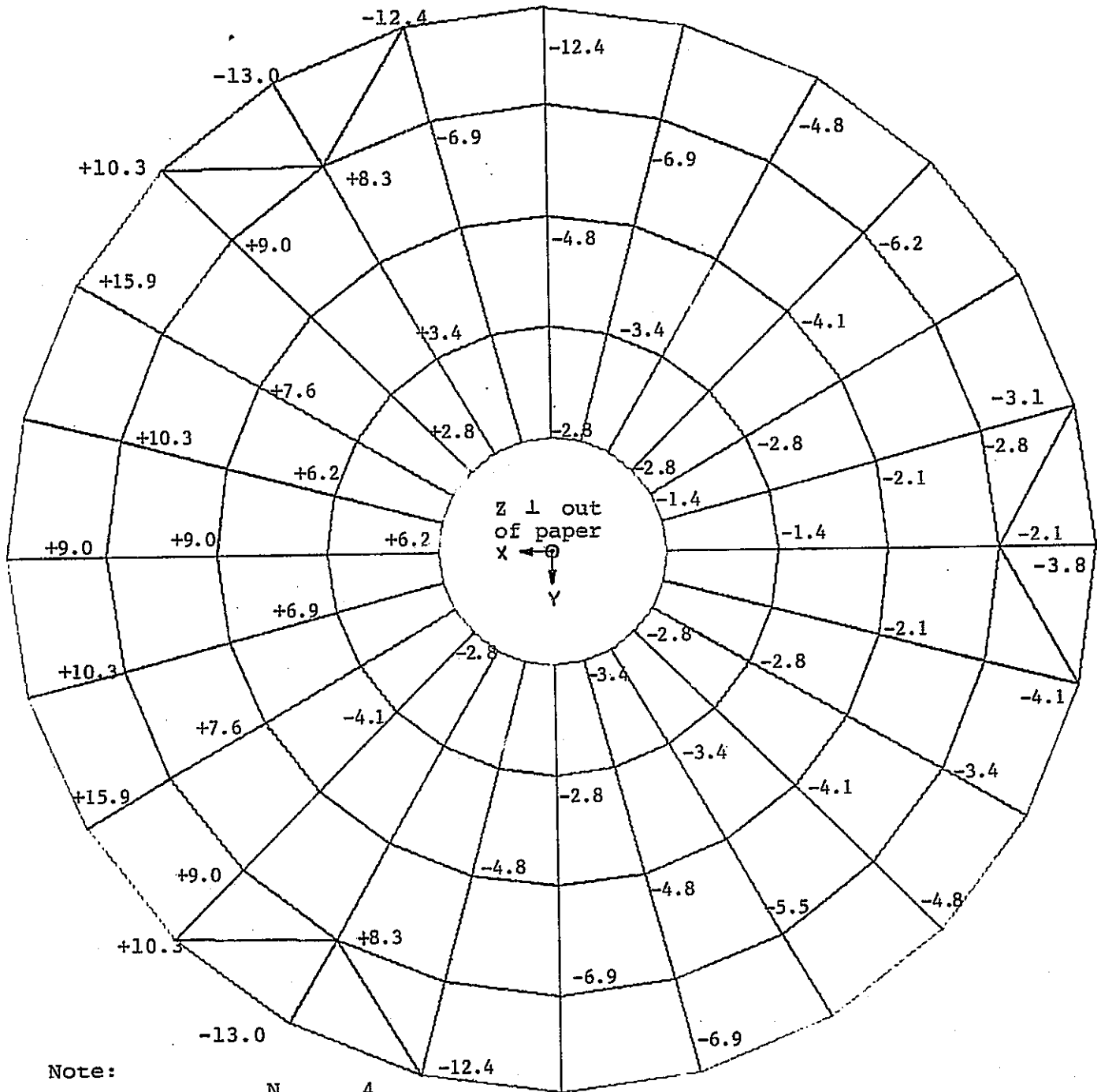

Figure 2.12 Deflection of Itek Mirror, lg Load in Y Direction

Figure 2.13 Stress Front Plate of Itek Mirror,
lg Load in x Direction



Note:

Stresses units ($\frac{N}{m^2} \times 10^4$)

+ sign = tension

Figure 2.14 Stress Front Plate of Itek Mirror,
lg Load in y Direction

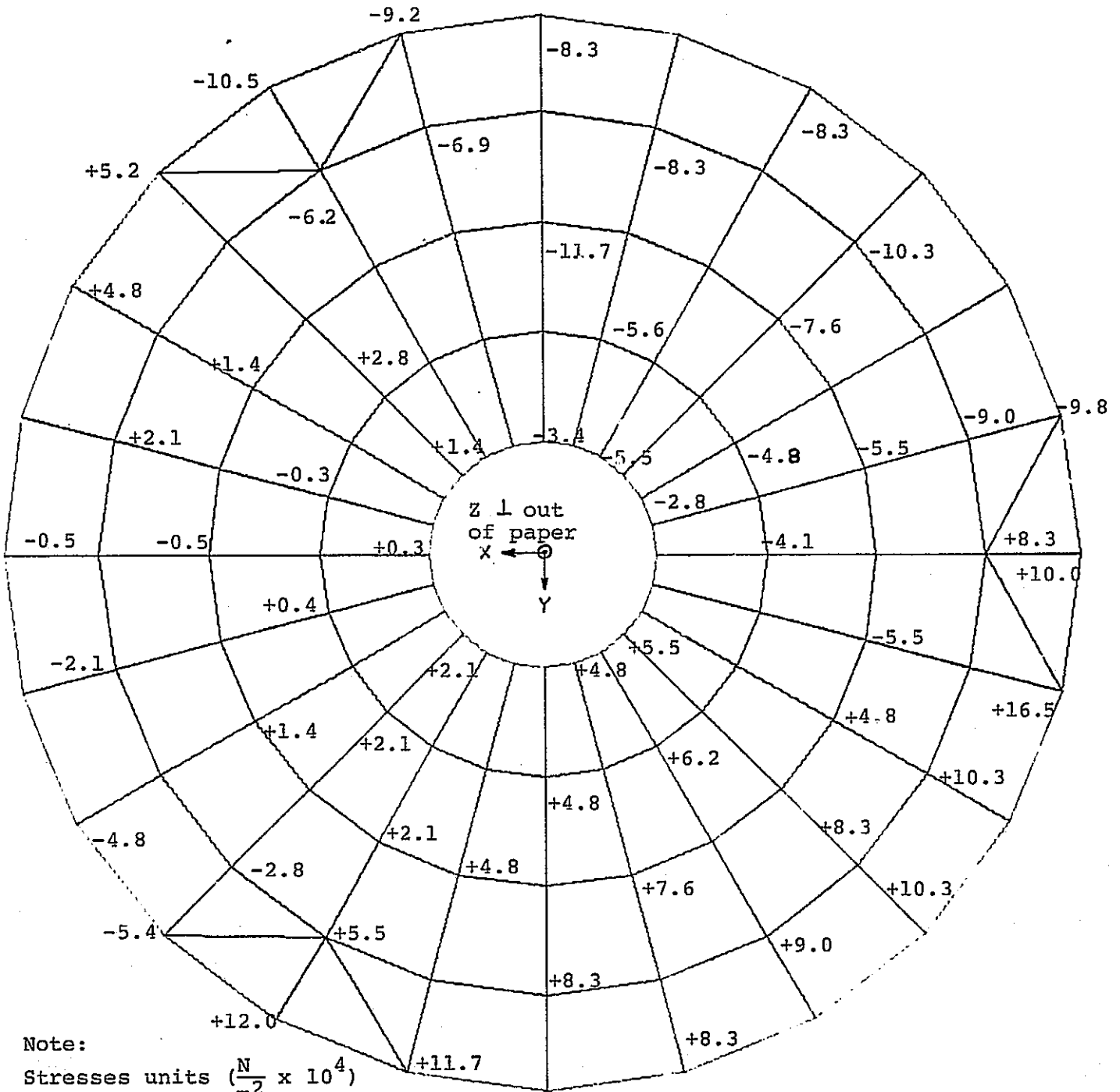

Note:

Stresses units ($\frac{N}{m^2} \times 10^4$)

+ sign = tension

Figure 2.15 Stress Back Plate of Itek Mirror,
lg Load in X-Direction

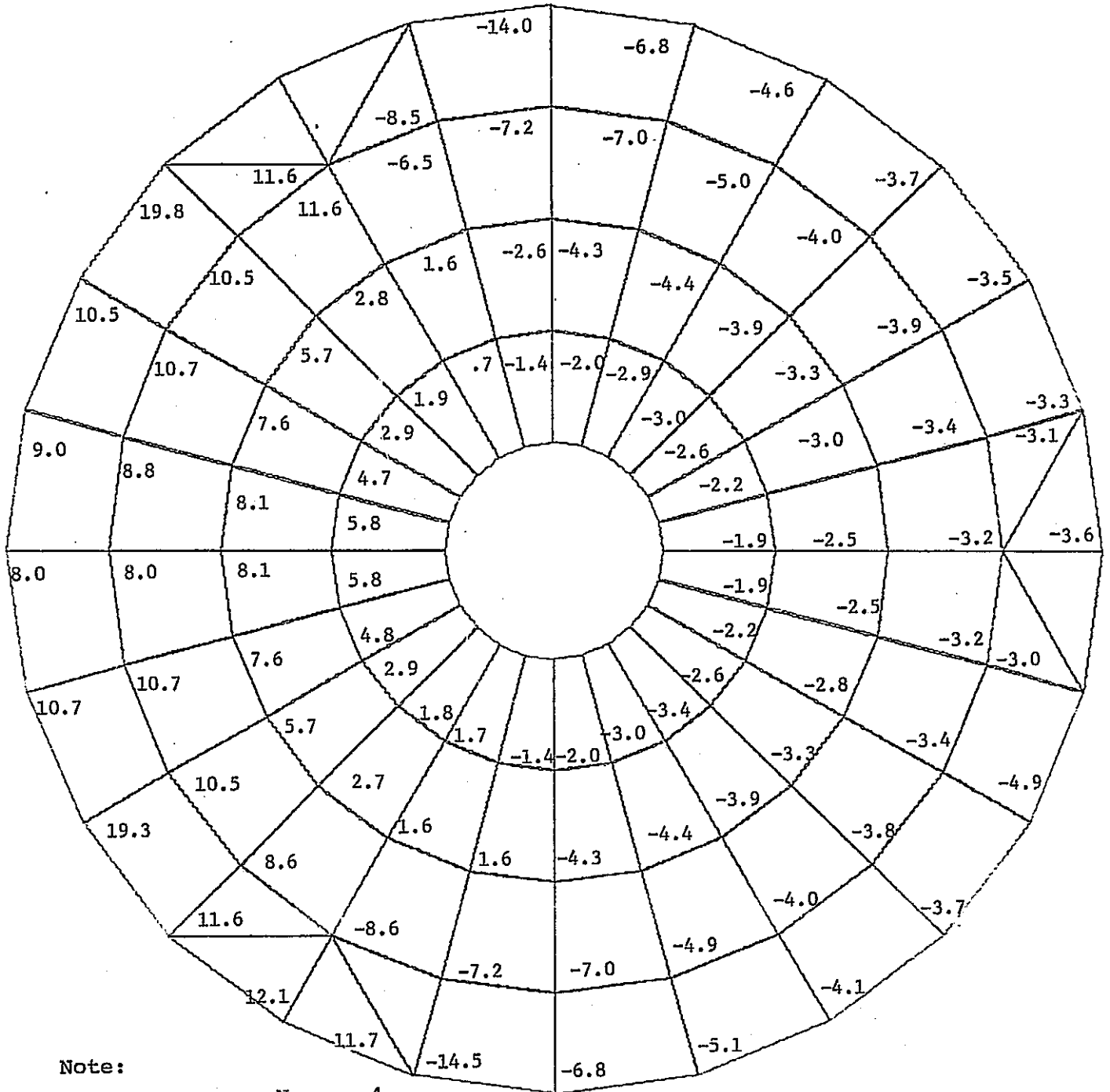

Note:

Stresses units ($\frac{N}{m^2} \times 10^4$)

+ sign = tension

Figure 2.16 Stress Back Plate of Itek Mirror,
1g Load in Y Direction

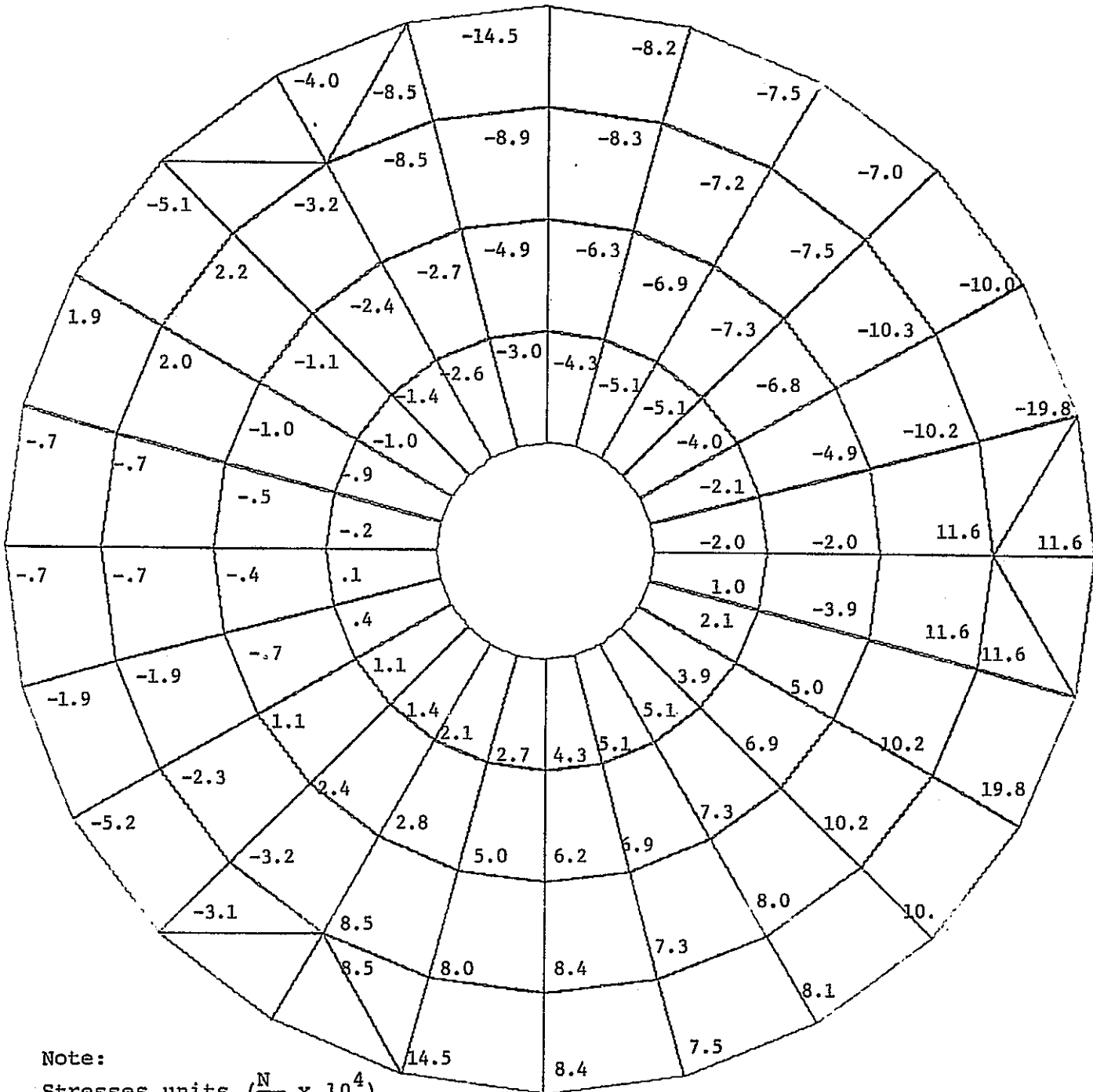

Note:

Stresses units $(\frac{N}{2} \times 10^4)$
m

+ Sign = tension

Figure 2.17 Stresses Front Plate of Perkin-Elmer Mirror
lg Load in x Direction

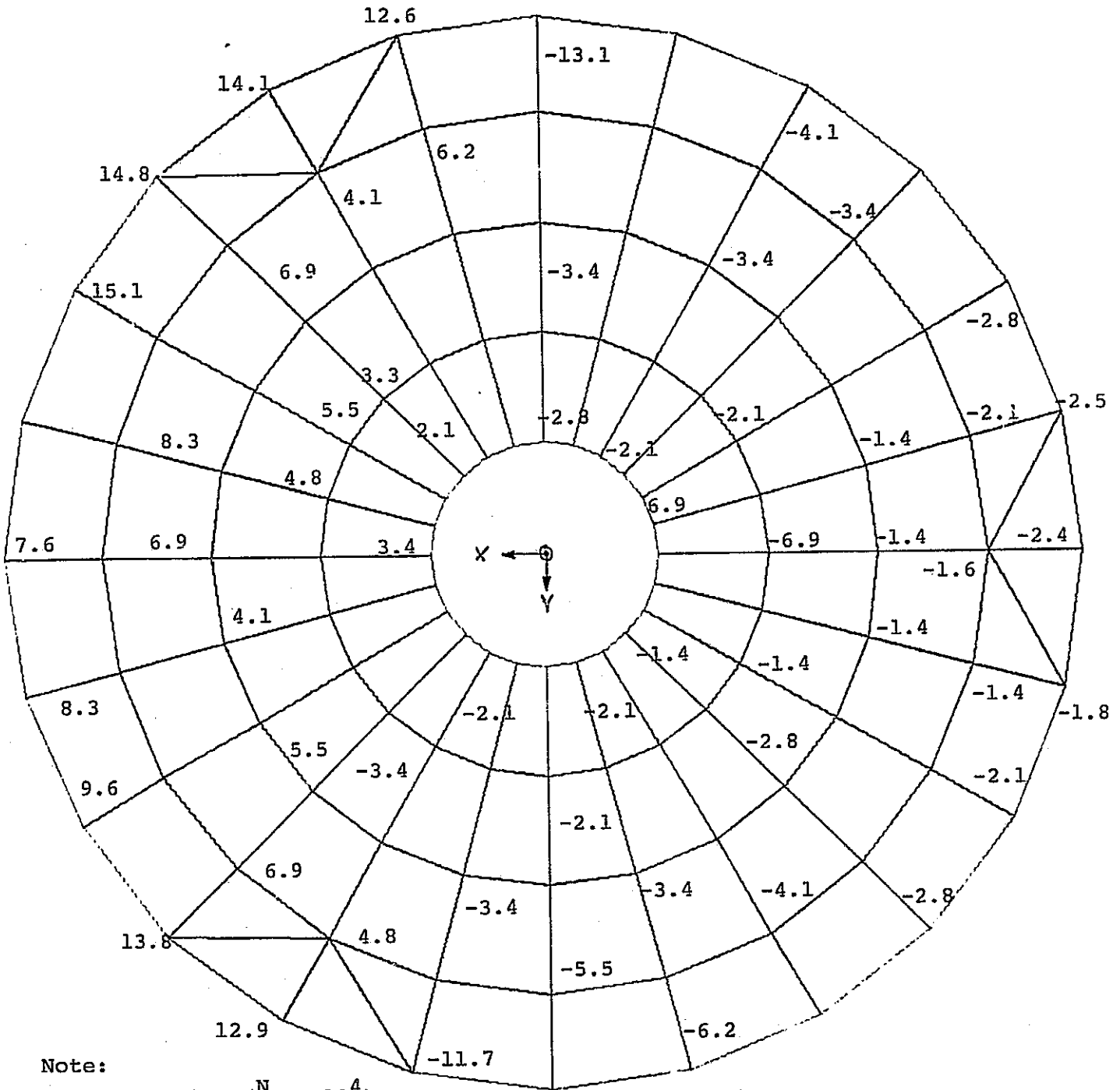

Note:

Stresses units ($\frac{N}{m^2} \times 10^4$)
+ sign = tension

Figure 2.18 Stresses Front Plate of Perkin-Elmer Mirror
lg Load in y Direction

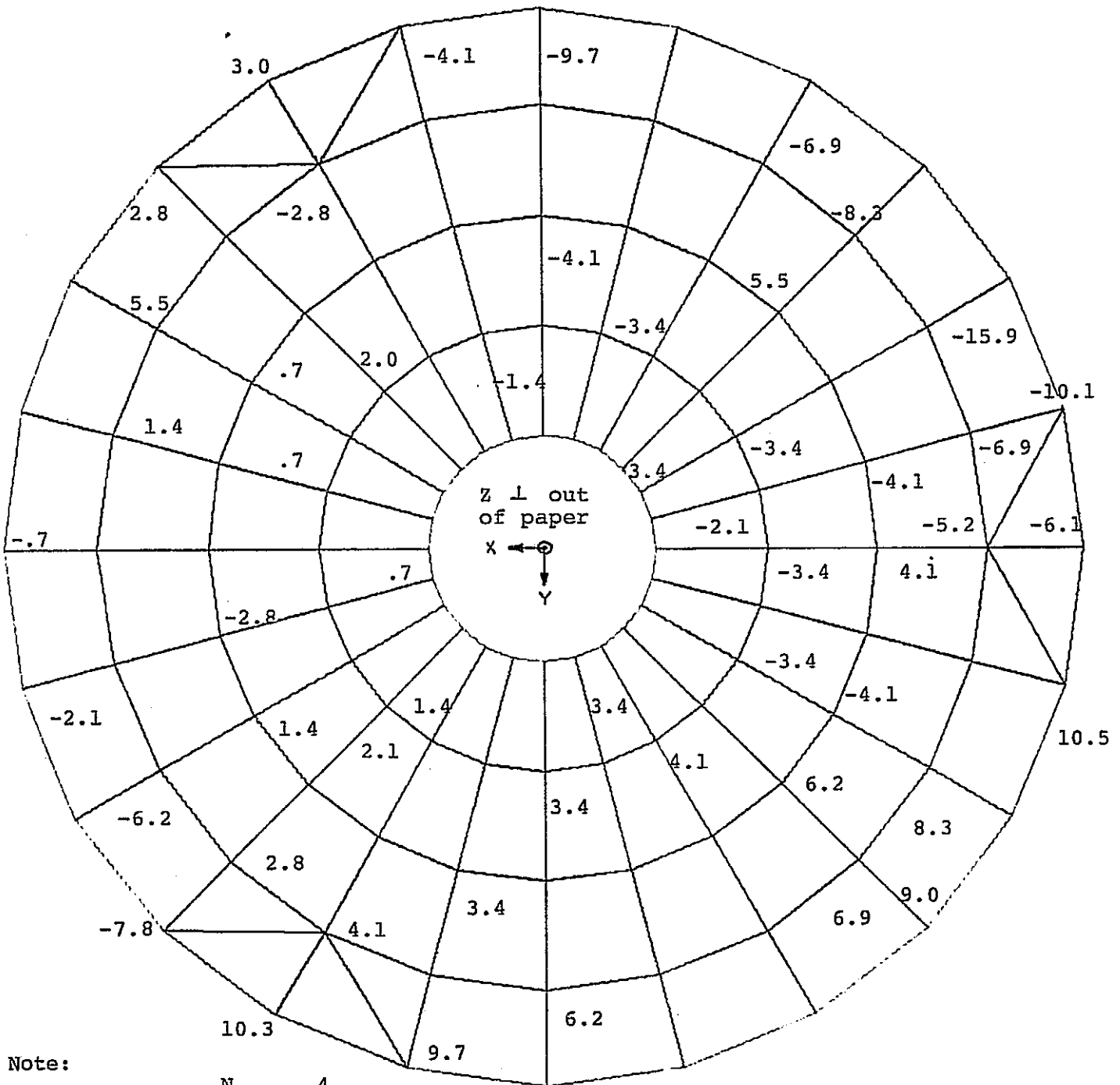

Note:
Stresses units ($\frac{N}{m^2} \times 10^4$)
+ sign = tension

Figure 2.19 Stress Back Plate of the Perkin-Elmer Mirror,
1g Load in X Direction

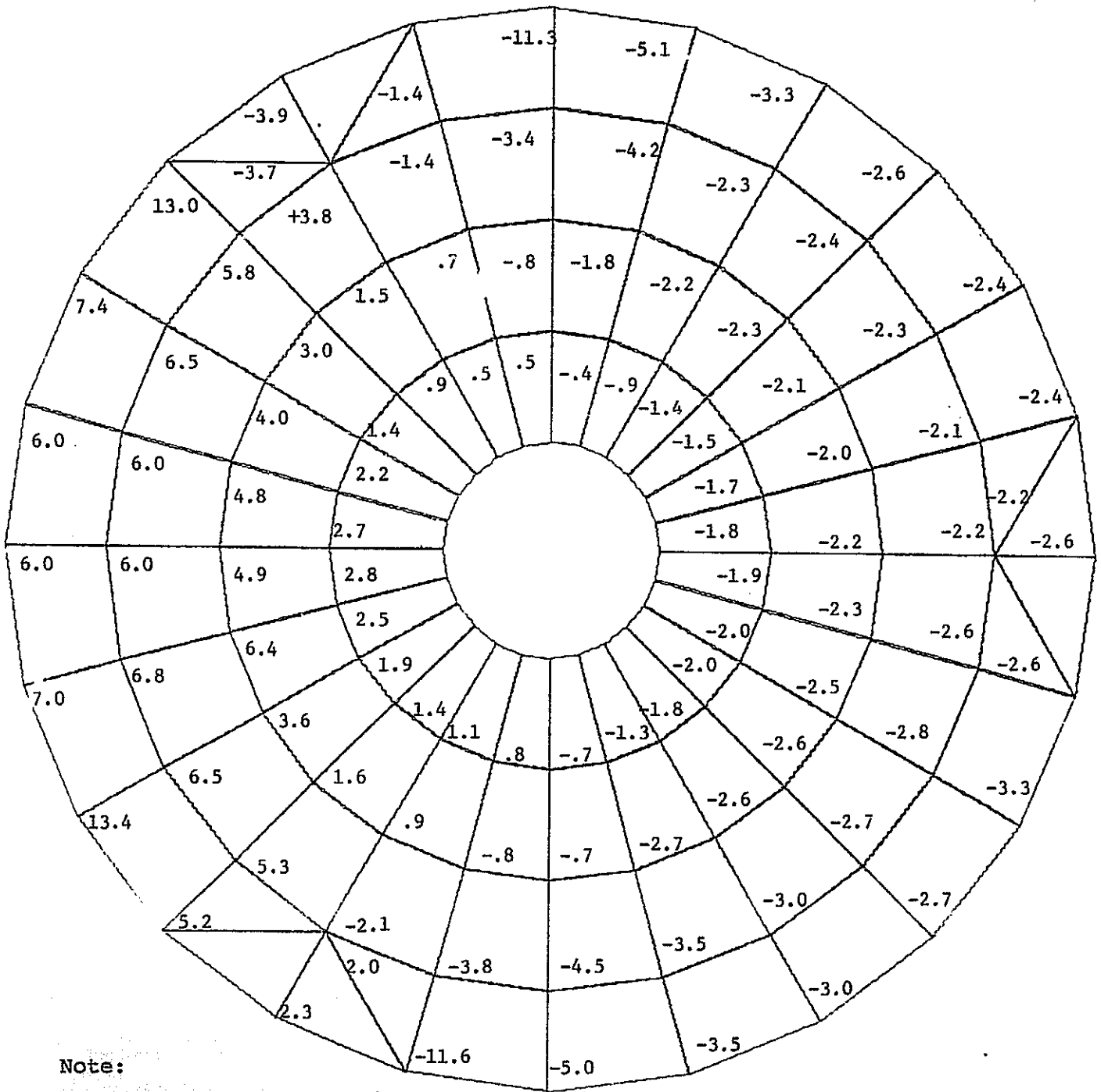

Note:

Stresses units $\left(\frac{N}{m^2} \times 10^4\right)$

+ sign = tension

Figure 2.20 Stress Back Plate of the Perkin-Elmer Mirror,
 1g Load in Y Direction

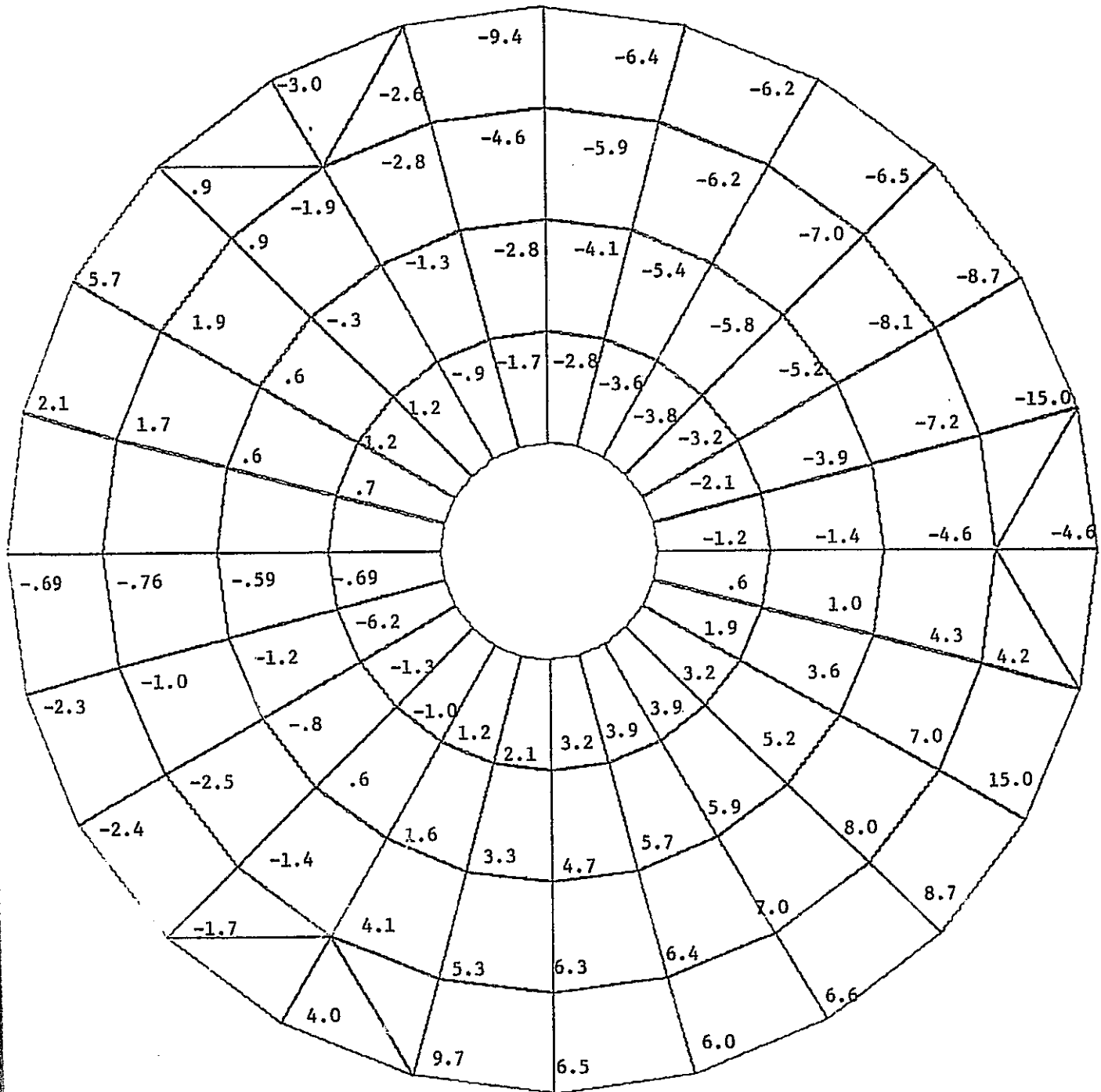

Note:

Stresses units ($\frac{N}{m^2} \times 10^4$)

+ sign = tension

Chapter 3

THERMAL LOAD EFFECTS ON THE ITEK AND PERKIN-ELMER MIRRORS

3.1 Thermal Loads

For the Itek CERVIT design four different sets of thermal expansion coefficients were used. The "nominal" coefficient ($\alpha = .05 \times 10^{-6} \text{M/M/}^{\circ}\text{C.}$) and those obtained at 10°C. , 15°C. and 25°C. for the particular blank available. Three different thermal loadings were imposed: a 1°F. uniform soak, a 1°F. axial gradient and a 1°F. radial gradient. This yielded twelve cases to be investigated.

For the Perkin-Elmer ULE design two sets of thermal expansion coefficients were used. The nominal coefficient ($\alpha = .03 \times 10^{-6} \text{M/M/}^{\circ}\text{C.}$) and those resulting from the radial variation of α as shown in Figure 3.1. The same three thermal loadings described above were applied. This yielded six additional cases.

3.2 Structural Models

The structural models used in this analysis are the same 60° segment models with equivalent solid cores that are described in Section 2.3. The variation of the thermal coefficient α with temperature for the material CERVIT for use in the analysis of the Itek mirror is shown in Figure 3.2. From that the values of α were derived and used to compute surface displacements. These values of α are given in Table 3.1.

Distribution of "α" in CERVIT Extreme Values*

	10 ⁰ C. Operation	15 ⁰ C. Operation	20 ⁰ C. Operation
Top Face	+6x10 ⁻⁸ M/M- ⁰ C	+2.0x10 ⁻⁸ M/M- ⁰ C	-1.5x10 ⁻⁸ M/M- ⁰ C
Core	+4x10 ⁻⁸ M/M- ⁰ C	-1.75x10 ⁻⁸ M/M- ⁰ C	-4.0x10 ⁻⁸ M/M ⁰ C
Bottom Face	+2x10 ⁻⁸ M/M- ⁰ C	-2.5x10 ⁻⁸ M/M- ⁰ C	-4.5x10 ⁻⁸ M/M- ⁰ C

* Information from NASA/MSFC Memo dated May 2, 1974
See Fig. 3.2

Table 3.1

A typical variation of α in a fabricated ULE light-weight mirror is given in Figure 3.1. Figure 3.3 shows a distribution of α that was used to compute a "worst case" condition for the Perkin-Elmer mirror.

3.3 Results

The peak deflections of the mirror surface, resulting from the 18 loading cases described in Section 3.1, are given in Table 3.2. Additionally, the contours of the deflected mirror surface for each case are shown in Appendix Figures A-3 through A-20.

Designer	Material	Structural Type of Model	Type of Thermal Gradient (°F)	Temperature Coefficient	Maximum Deflection, -Z Direction 10^{-9} in or (10^{-7}) in			Fig. No.
					Δ	Peak to Peak *	RMS *	
ITEK	CERVIT	60° segment equivalent solid core	1° Soak	Nominal	5.33 (2.1)	3.05 (1.2)	.71 (.28)	A3
PERKIN-ELMER	U.L.E.		1° Soak	Nominal	4.50 (1.77)	1.93 (.76)	.38 (.15)	A15
ITEK	CERVIT		1° Soak	10°C Thermal Coefficient	49.02 (19.3)	7.11 (2.8)	1.52 (.60)	A6
ITEK	CERVIT		1° Soak	15°C Thermal Coefficient	55.88 (22.0)	6.10 (2.4)	1.50 (.59)	A9
ITEK	CERVIT		1° Soak	20°C Thermal Coefficient	35.56 (14.0)	3.86 (1.52)	.96 (.38)	A12
PERKIN-ELMER	U.L.E.		1° Soak	Variable	38.61 (15.2)	3.05 (1.2)	1.02 (.40)	A18
ITEK	CERVIT		1° Axial	Nominal	83.82 (33.0)	2.34 (.92)	.41 (.16)	A4
PERKIN-ELMER	U.L.E.		1° Axial	Nominal	51.56 (20.3)	1.14 (.45)	.23 (.09)	A16
ITEK	CERVIT		1° Axial	10°C Thermal Coefficient	47.24 (18.6)	2.41 (.95)	.56 (.22)	A7
ITEK	CERVIT		1° Axial	15°C Thermal Coefficient	36.07 (14.2)	1.98 (.78)	.43 (.17)	A10
ITEK	CERVIT		1° Axial	20°C Thermal Coefficient	71.88 (28.3)	2.01 (.79)	.46 (.18)	A13
PERKIN-ELMER	U.L.E.		1° Axial	Variable	39.88 (15.7)	2.54 (1.0)	.97 (.38)	A19
ITEK	CERVIT		1° Radial	Nominal	7.11 (2.8)	4.06 (1.6)	.91 (.36)	A5
PERKIN-ELMER	U.L.E.		1° Radial	Nominal	4.32 (1.7)	2.03 (.80)	.36 (.14)	A17
ITEK	CERVIT		1° Radial	10°C Thermal Coefficient	28.70 (11.3)	6.86 (2.7)	1.45 (.57)	A8
ITEK	CERVIT		1° Radial	15°C Thermal Coefficient	26.42 (10.4)	4.29 (1.69)	.84 (.33)	A11
ITEK	CERVIT		1° Radial	20°C Thermal Coefficient	13.2 (5.2)	1.96 (.77)	.43 (.17)	A14
PERKIN-ELMER	U.L.E.		1° Radial	Variable	14.73 (5.8)	1.45 (.57)	.53 (.23)	A20

* Peak to Peak and RMS from Best Fit Sphere.

Table 3.2

Maximum Deflections of Itek and Perkin-Elmer Mirror Surfaces Under Thermal Loads

ORIGINAL PAGE IS
OF POOR QUALITY

Data From Corning Visit 26/3/74

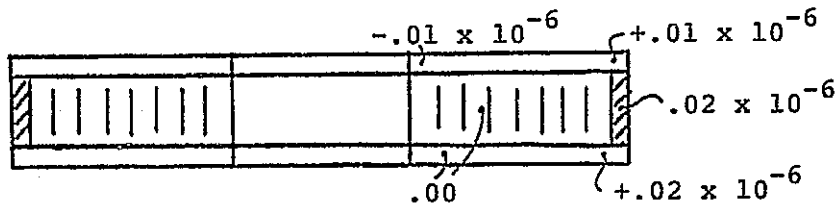
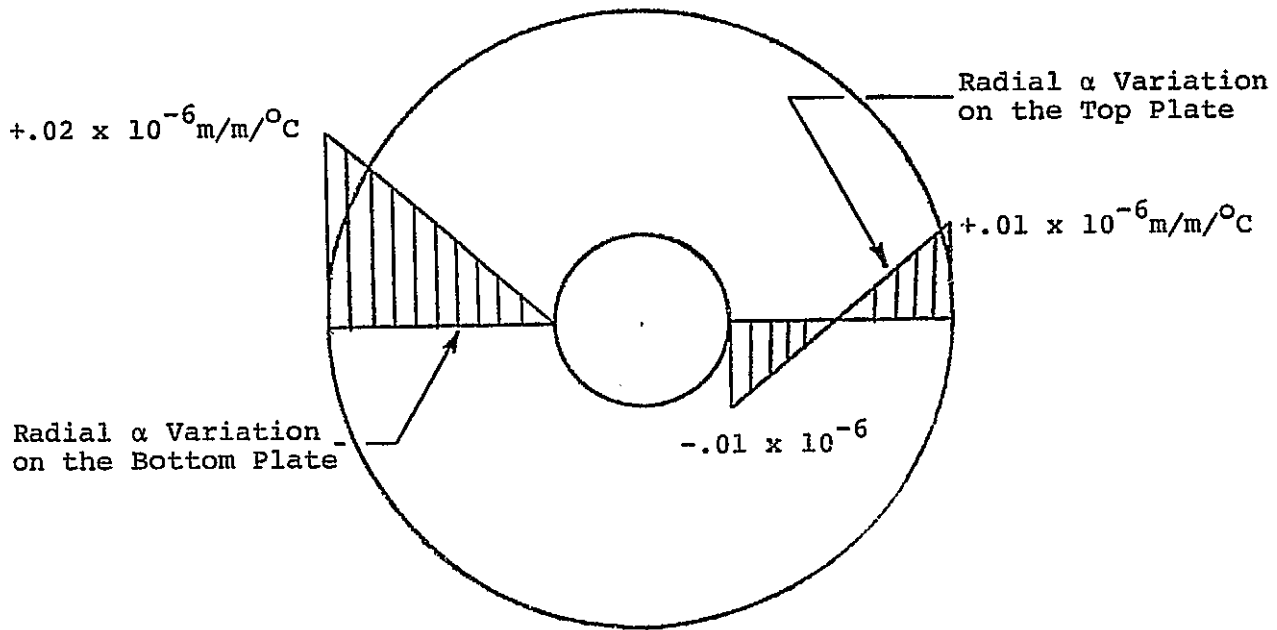

Nominal $\alpha = .03 \times 10^{-6} \text{ m/m/}^\circ\text{C}$

Figure 3.1 Radial Variation of Thermal Expansion Coefficient α , Perkin-Elmer Mirror

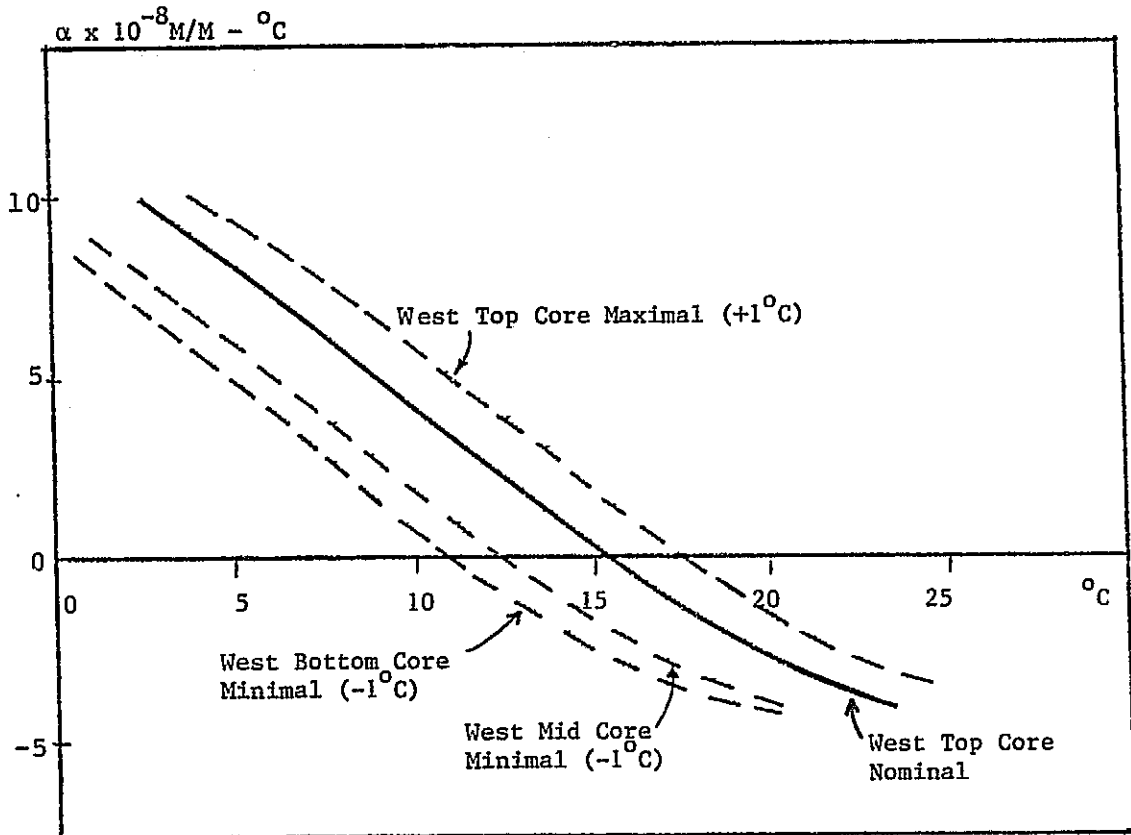

CERVIT 101 "α" Variations

Data from May 2/74 NASA/MSFC S&E-SSL-PO/TCOR

Nominal α : $.05 \times 10^{-6} \text{ M/M} \cdot ^\circ\text{C}$

Figure 3.2 Variation of Thermal Expansion Coefficient α With Temperature

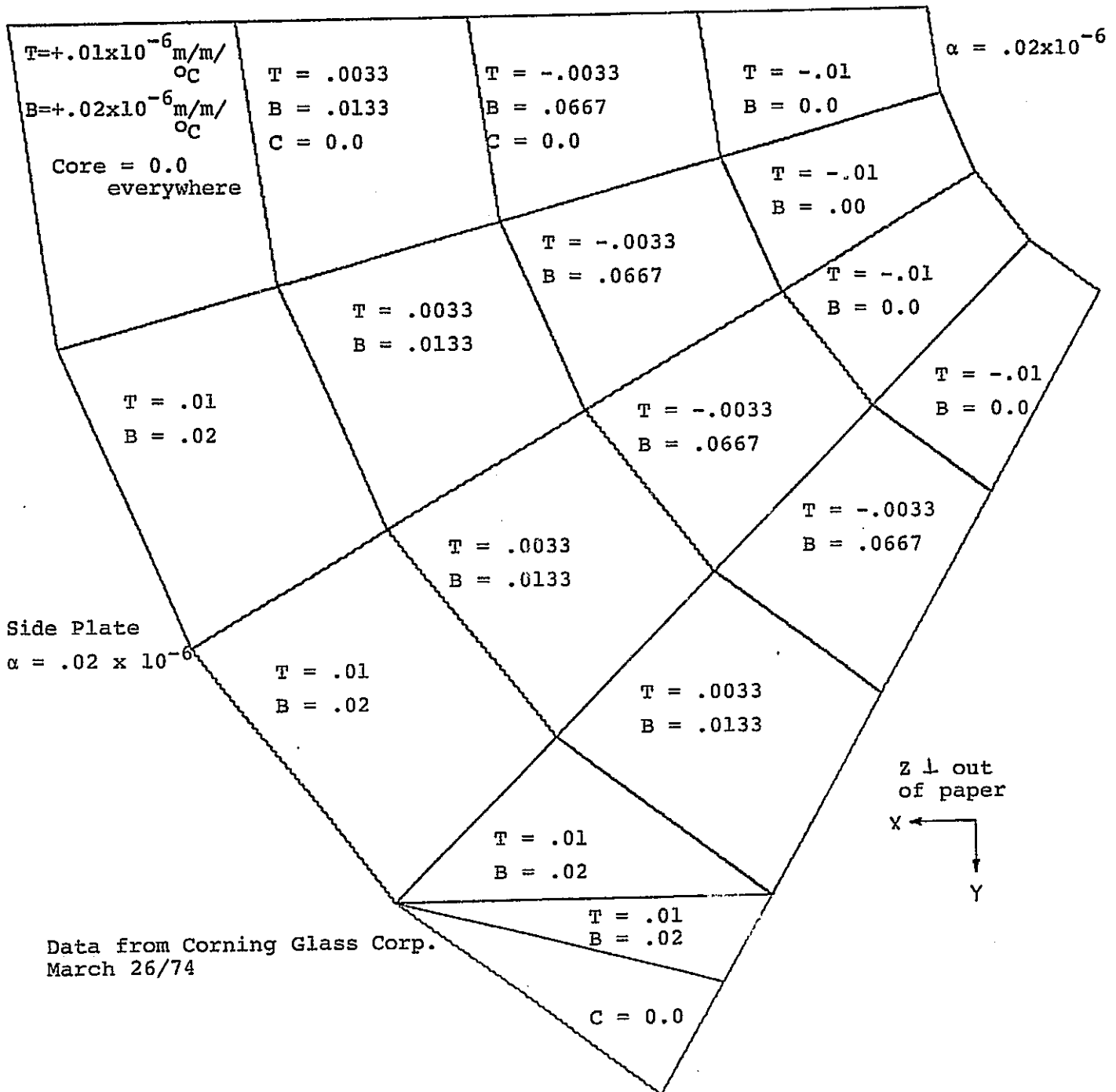

Figure 3.3 Probable Distribution of Thermal Expansion Coefficient of α in U.L.E. Mirror

Chapter 4

STRUCTURAL EVALUATION OF THE BOEING MIRROR LIGHTWEIGHTING CONCEPT

4.1 Description of Mirror Design

The properties of the Boeing mirror that were analyzed are listed in Table 4.1:

Outside Diameter	122" (3.099m)
Inside Diameter	23.5" (.597m)
Spherical Radius of Curvature	525" (13.335m)
Radial Thickness	17.38" (.442m)
Cell Shape	Hexagonal
Cell Pitch	4.8" (.122m)
Top Plate Thickness	1.83" (.047m)
Bottom Plate Thickness	1.64" (.042m)
Bottom Plate Hole Diameter	3.25" ϕ (.083m)
Edge Band Thickness	.40" (.0102m)
Cell Wall Thickness	.20" (.0051m)
Material	CERVIT 101
Total Weight Mirror	4500 lbs. (2045 Kg)

Table 4.1

Properties of Boeing Mirror

The "Boeing" mirror in nearly all ways resembles the Itek mirror. It is machined from a solid blank of CERVIT and has a hexagonally-lightweighted core. It differs from the Itek design in that additional lightweighting has been provided by machining away the inner and outer circumferential edge bands and lightweighting those partial cells from the edge. Thus all cells in the mirror are uniform. This supposedly reduces the cost and risk of normal light-weighting.

During operation the mirror is again held at three cylindrical trunnions, 120° apart, at the mid-height of the outside edge with supports allowing expansion in the radial direction.

4.2 Gravity Load

A gravity load was applied in the direction of the optical axis (-Z direction).

4.3 Structural Model

The structural model was similar to the Itek Phase A "exact" model. That is, both the top and bottom plates and the hexagonally-shaped cells of the core were modeled with plate elements and the support areas with three-dimensional solids. A 60° segment of the mirror, including part of one support on the outside circumference was modeled. Roller supports were provided along the radial edges. The model is shown in Figure 4.1.

4.4 Results

A comparison of the deflection of the Boeing mirror with various other very similar design concepts that were

evaluated in Phase A is shown in Table 4.2. Optical surface deformations are presented in Figure A-21. The tensile stresses in the top plate, the bottom plate and the lightweighted cell webs are shown in Figures 4.2, 4.3 and 4.4.

COMPARISON OF DISPLACEMENTS

Model	Gravity Load			Thermal Load		
	Max	Peak to Peak	RMS	1°F Rad.	1°F Axial	1°F Soak
Exact	818 (322)	754 (297)	168 (66)	8.38 (3.3)	6.10 (24)	4.32 (1.7)
Alternate Webs	884 (348)	836 (329)	218 (86)	7.62 (3.0)	6.10 (24)	4.32 (1.7)
Approximate	820 (323)	655 (258)	142 (56)	7.37 (2.9)	8.13 (32)	5.84 (2.3)
Boeing Concept	909 (358)	1190 (467)	213 (84)			

Units 10^{-8} M (10^{-6} in.)

Units 10^{-9} M (10^{-7} in.)

Table 4.2 *

* Reference to Phase A results

4-4

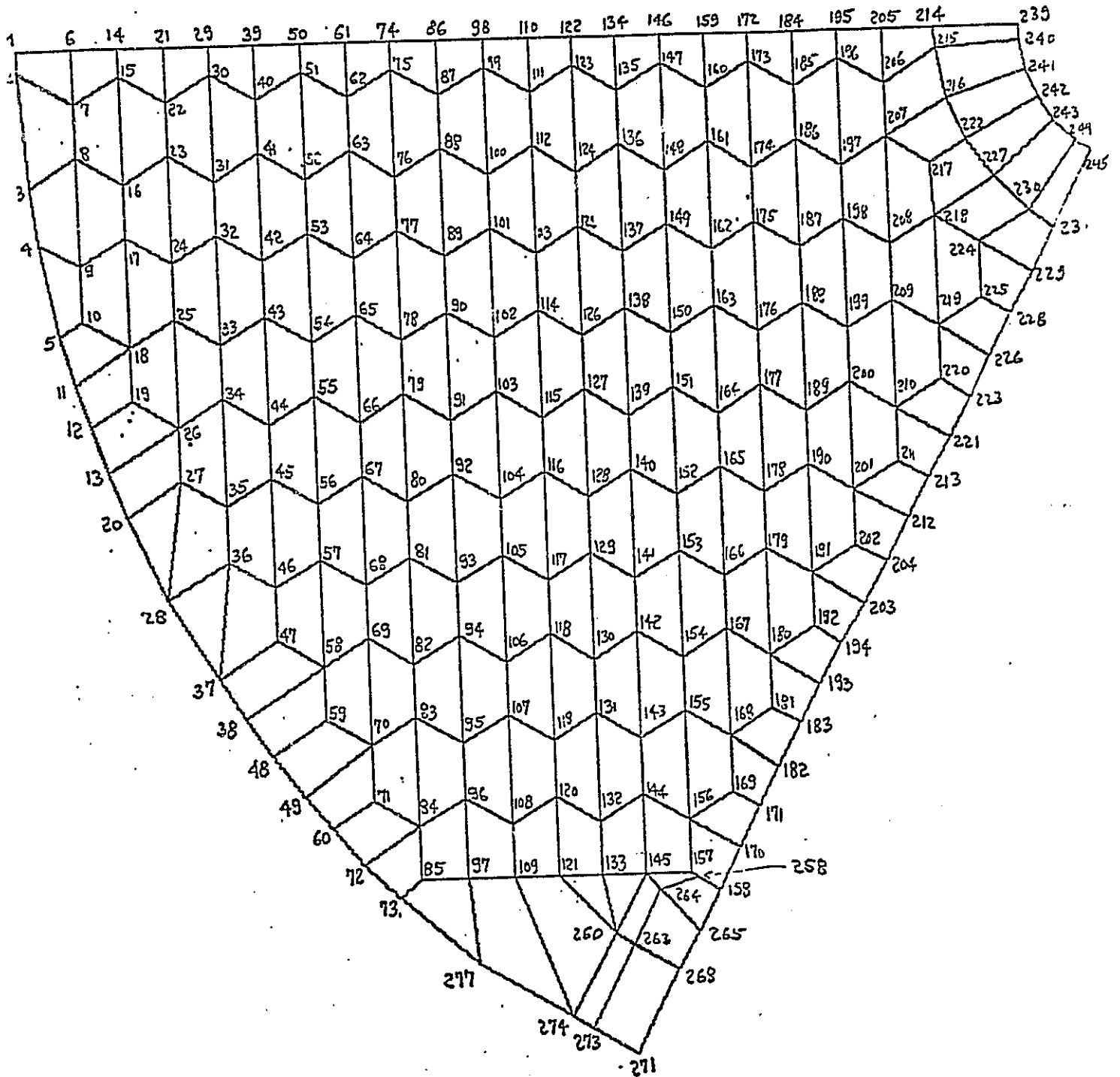
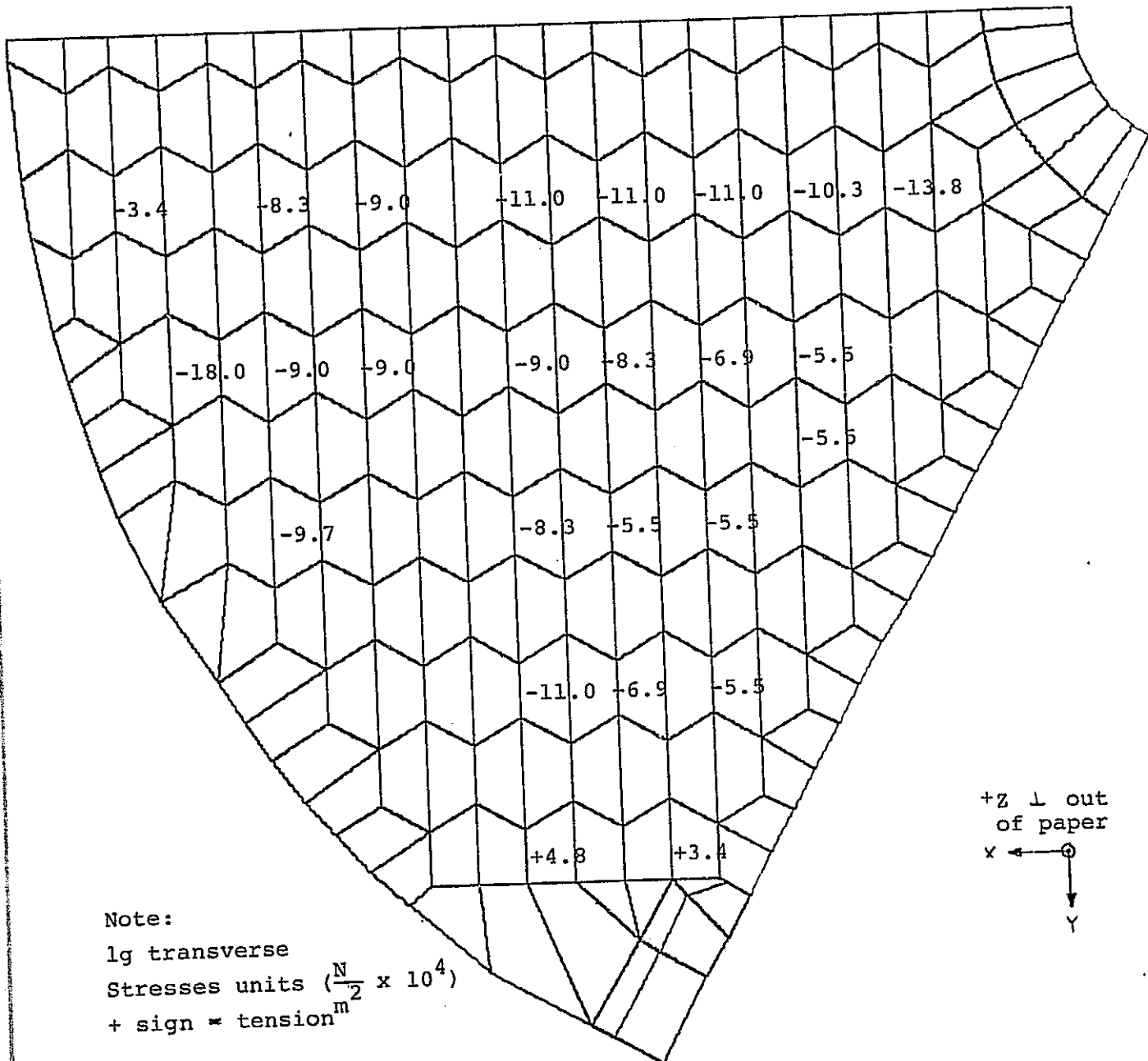

Figure 4.1 Boeing Concept Mirror, Finite Element Model of the Optical Surface



Note:
 lg transverse
 Stresses units ($\frac{N}{m^2} \times 10^4$)
 + sign = tension

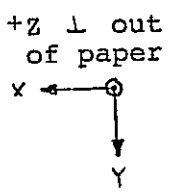

Figure 4.2 Boeing Concept Mirror, Maximum Stresses in the Top Plate

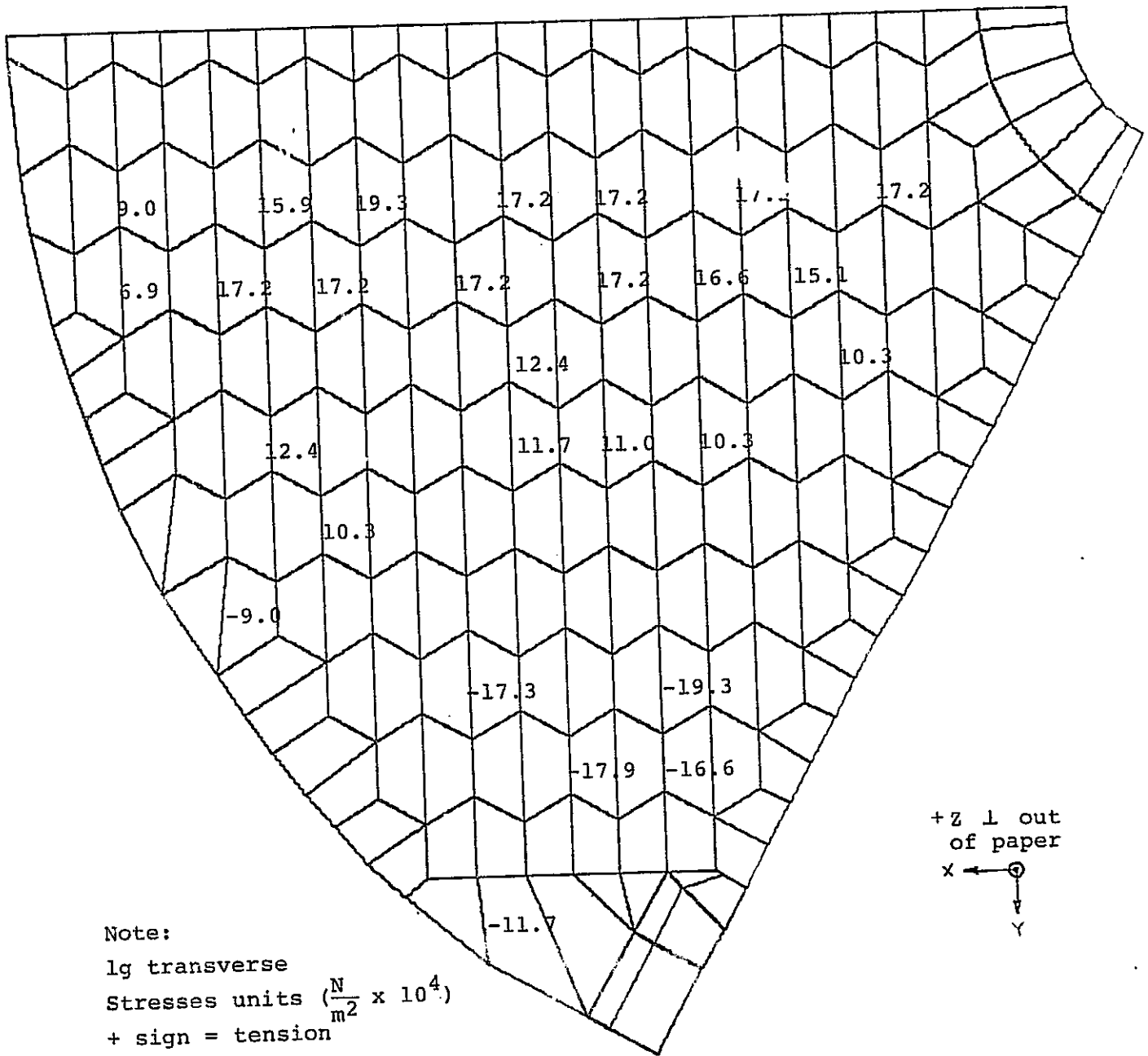

Figure 4.3 Boeing Concept Mirror, Maximum Stresses in the Bottom Plate

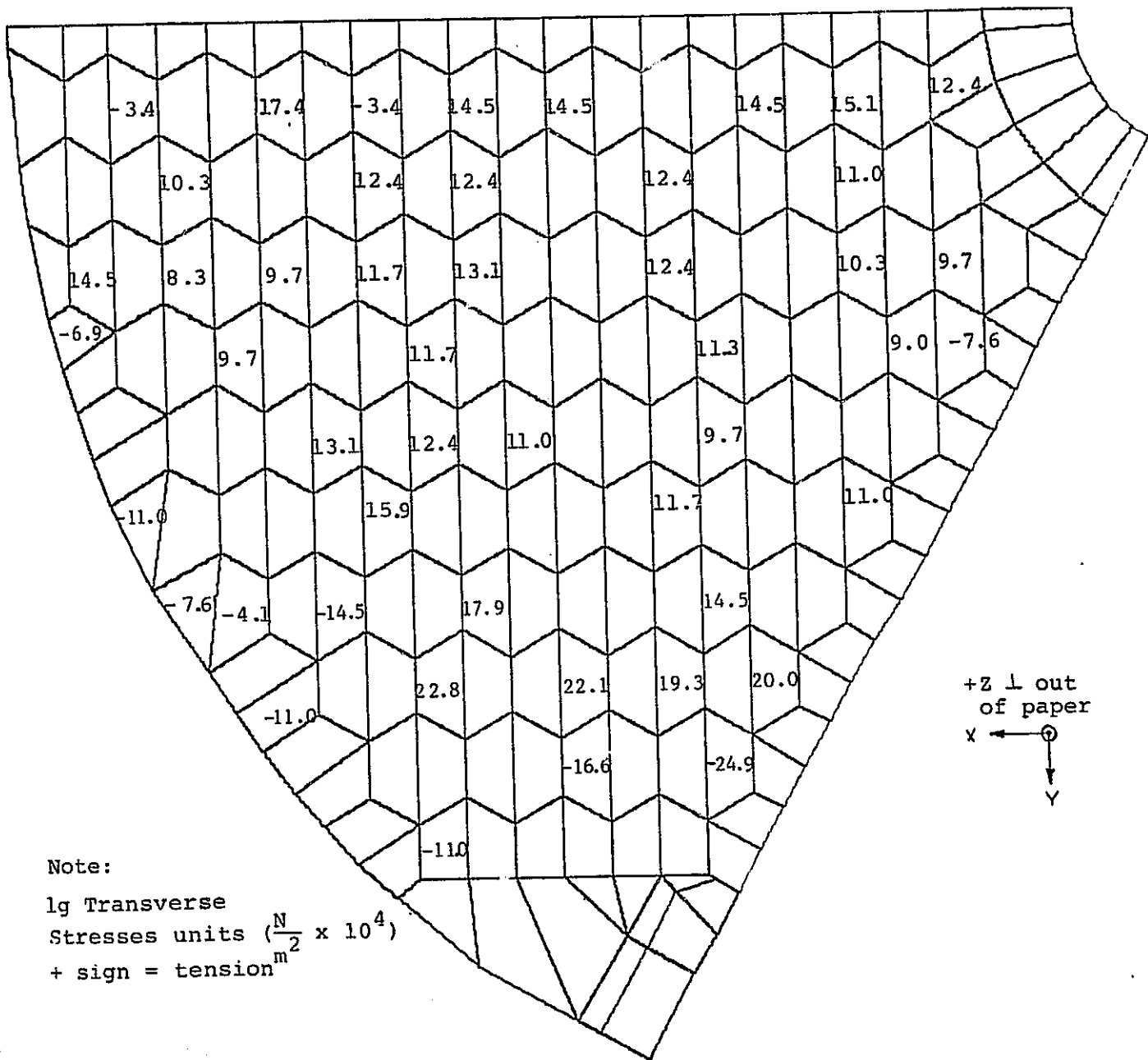

Figure 4.4 Boeing Concept Mirror, Maximum Stresses in the Core Webs

Chapter 5

ADDITIONAL STUDIES

5.1 Study to Determine The Effect of Cell Plate Deflection

The deflection at the center of a hexagonal light-weighting cell plate relative to the edges has usually been considered to be of second order. In any case the model to evaluate this in one step is likely to be prohibitive in cost. A study was conducted to determine whether the assumption that this deflection is of second order was justifiable.

Using the results of the Itek Phase A exact mirror analysis for the case a 1G load parallel to the optical axis, the nodal deflections at the six corners of each hexagonal cell were averaged at the center. The deflection at the center of a thick hexagonal plate under a 1G load was calculated and added to the averaged deflections, thus obtaining a corrected deformation of the optical surface. The results of the study are shown in Table 5.1.

MODEL	MAX Δ	Peak to Peak	RMS
Itek Phase A "Exact"	813 (320)	754 (297)	168 (66)
Itek Phase A "Exact" plus Cell Deflection	818 (322)	757 (298)	170 (67)

NOTE: Units M x 10⁻⁸ or () IN.X 10⁻⁶

Table 5.1
COMPARISON OF DISPLACEMENTS
ITEK PHASE A "EXACT" MIRROR

5.2 Fracture Toughness in CERVIT and ULE

The basic fracture toughness equations for Mode I and Mode II loading are given and comparisons are made between the expected performance of ULE and CERVIT.

In the manufacture of lightweight large optical mirrors, it is likely that there will be regions of separation between the core and the front face plate of the mirror as well as cracks caused by the machining of the material. In order to estimate the critical separation or crack length (l_c), which could propagate under stress and destroy the mirror, one must consider linear elastic fracture mechanics. For the Mode I fracture mode (Figure 5.1) the specimen is assumed to be in a state of plane stress, with the loading perpendicular to the length of the crack. For a given crack length (c), the crack will propagate when

$\sigma_F = \frac{K_{Ic}}{\sqrt{\pi c}}$, where σ_F = fracture stress. The same expression

is true for the Mode II fracture mode with τ_F replacing σ_F and K_{IIc} replacing K_{Ic} , where τ_F is the fracture shear stress. K_{Ic} and K_{IIc} are the stress intensity factors for Mode I and Mode II fracture proposed originally by Irwin.

Some data appears to be available on K_{Ic} for ULE and CERVIT but not on K_{IIc} . K_{Ic} for ULE is approximately 640 psi $\sqrt{\text{in}}$ (Corning data). Since the critical problem seems to be the lack of bonding between the core matrix and front face of the mirror, where there is low normal stress and high shear stress, Mode II fracture will prove particularly critical for ULE. An approximate rule of thumb is that K_{IIc} is twice K_{Ic} .

Assuming this relationship for K_{II_C} and that the debond surface between center matrix and mirror face experiences only shear stress, the curve in Figure 5.2 was generated.

The probability of failure in a brittle material subjected to a given stress is

$$\phi = 1 - \exp(-A \int_0^{S_D} g(s) ds) \quad (5.1)$$

where A = Area of part under stress

S_D = Design stress

$g(s)$ = Flaw density function

$g(s)$ is assumed independent of surface area, but is strongly dependent on surface preparation:

$$g(s) = \frac{1}{A} \frac{d\phi}{ds} \left(\frac{1}{1-\phi(s)} \right) \quad (5.2)$$

Generating $\phi(s)$ and $\frac{d\phi}{ds}$ from Figure 5.3 at $S = 5500$ psi, one obtains $g(s) = 1.681 \times 10^{-5}$. Assuming a linear relation for $g(s)$ between $S = 0$ and 5500 psi, one obtains $g(s) = .306 \times 10^{-5}$ for $S = 1000$ psi. Again using a linear variation for $g(s)$ between 0 and 1000 psi, a probability of failure of .015 is obtained for a design stress of 1000 psi and an area of 10 in.² Using $S = 200$ psi gives $g(s) = .06 \times 10^{-5}$ and $\phi = 6.11 \times 10^{-4}$ for an area of 10 in.²

Unfortunately, the paucity of data for CERVIT makes it impossible to extrapolate the $g(s)$ curve back to zero stress. This is needed to generate a probability of failure for CERVIT at a shear stress of either 200 or 1000 psi. Figure 5.4 is enclosed to illustrate this.

It is recommended that four point bend tests be run for both ULE and CERVIT, but in particular for CERVIT, to generate the flaw density curve ($g(s)$) around 1000 psi. Much larger samples ($> 10 \text{ in.}^2$) should be tested to determine this part of the curve. Also, K_{II_C} tests for both CERVIT and ULE should be done.

5.3 Flexibility Matrices for the Itek and Perkin-Elmer Mirror for Use in The Study of Active Figure Control

The flexibility matrix is defined by

$$\{u\} = [C] \{P\} \quad (5.3)$$

where C_{ij} \equiv Flexibility matrix
 P_j \equiv Forces vector
 u_i \equiv Displacement vector

The flexibility matrix defines a displacement at i due to a unit load at j . Flexibility matrices for both the Itek and Perkin-Elmer mirrors were obtained by applying unit loads parallel to the optical axis (+Z direction) at each node on the back surface of the mirrors. The finite element models that were used were the 360° structural models described in Section 2.3. The flexibility matrices are given in Appendix B.

Mode I Loading

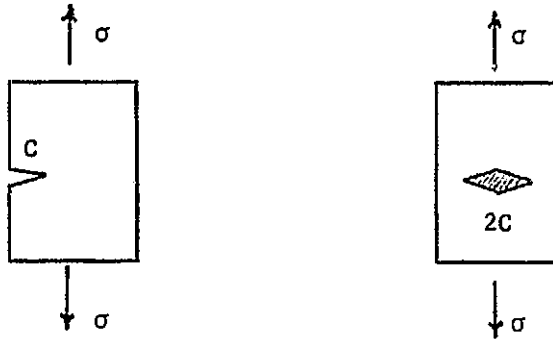

$$c_c = \frac{1}{\pi} \left(\frac{K_{Ic}}{\sigma} \right)^2$$

CERVIT: $K_{Ic} = 850 \text{psi} \sqrt{\text{in.}}$

ULE: $K_{Ic} = 640 \text{psi} \sqrt{\text{in.}}$

Mode II Loading

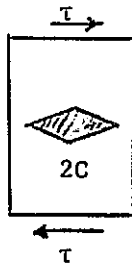

"Rule of Thumb"

$$K_{IIc} = 2 \times K_{Ic}$$

$$c_c = \frac{1}{\pi} \left(\frac{K_{IIc}}{\tau} \right)^2$$

Figure 5.1 Critical Stress Intensity Factors: K_{Ic} , K_{IIc}

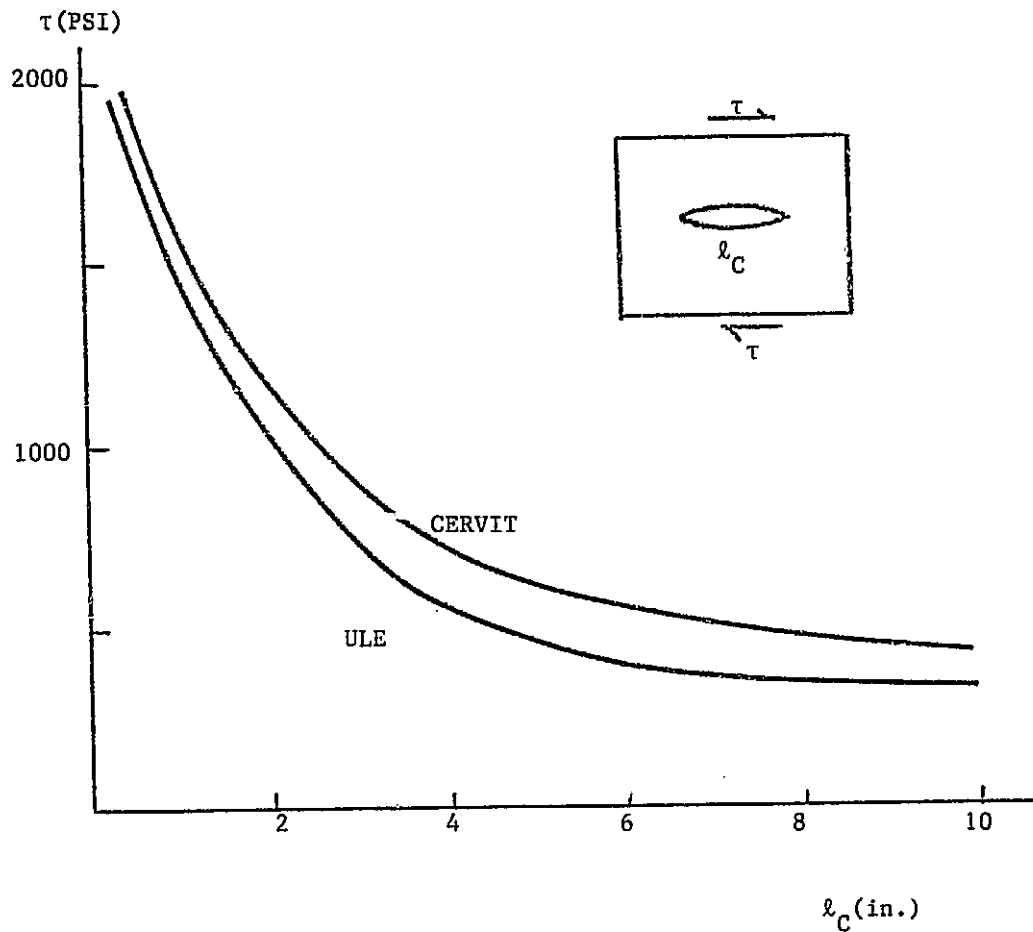

Applied Shear Loading (τ) and Critical Crack Length (Debond) (ℓ_c)

In Current Design $\tau \approx 200\text{PSI}$

$\ell_c \approx 10''$

Figure 5.2 Applied Shear Loading vs Critical Crack Length

Figure 5.3 Fracture Probability of ULE Corning 7971, Abraded

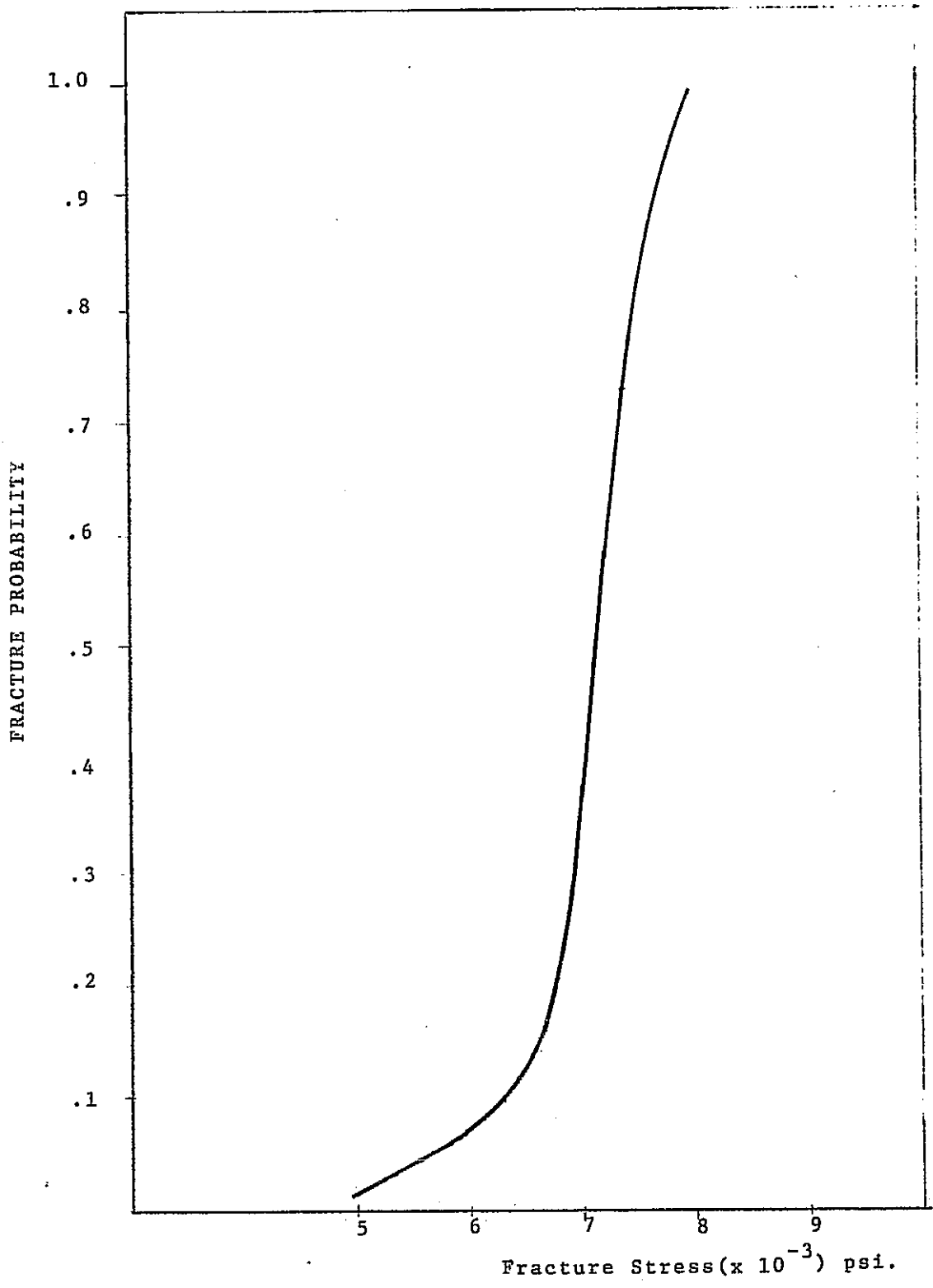
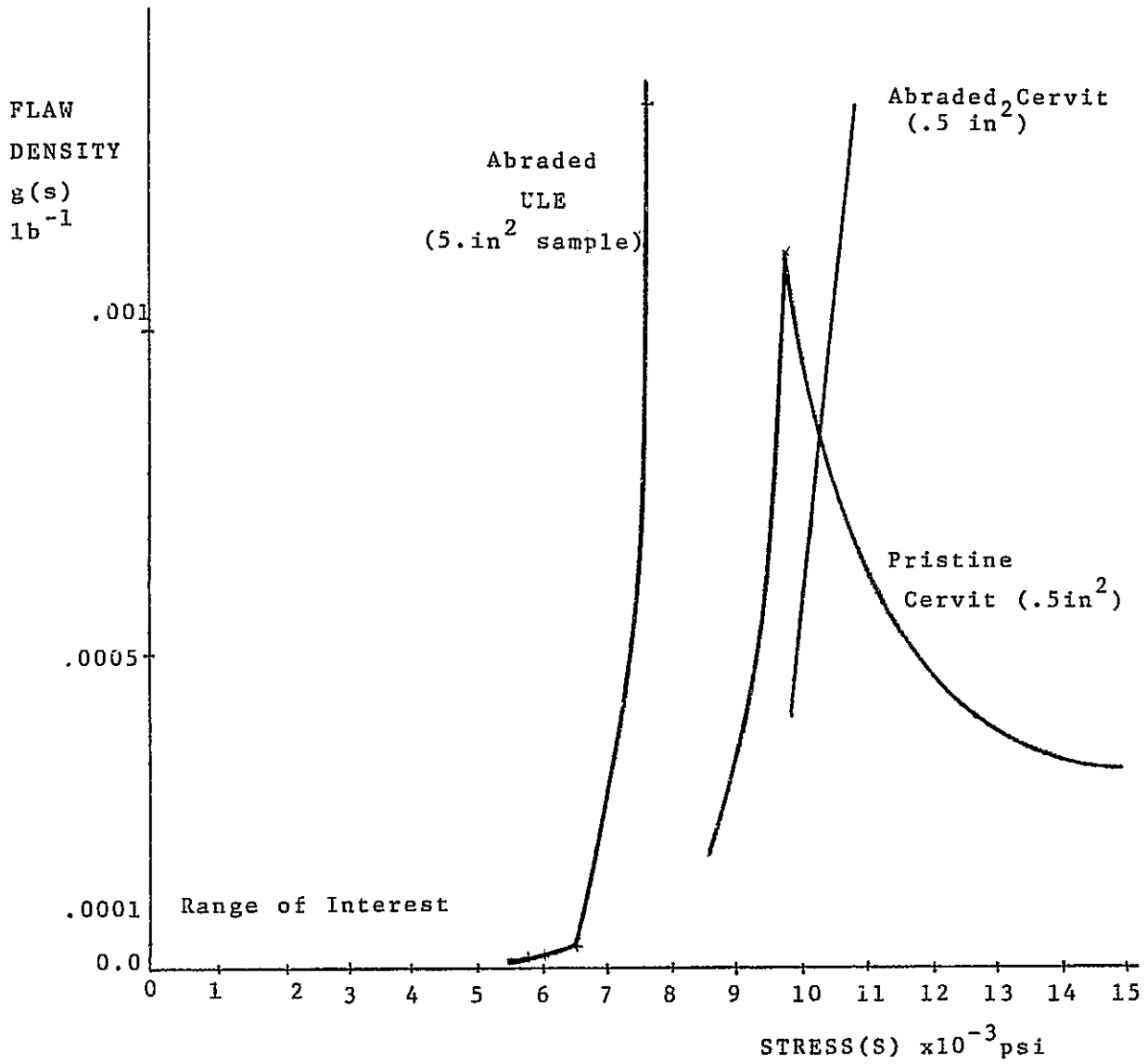

Figure 5.4 Flaw Density vs Stress



CHAPTER 6

SUMMARY, CONCLUSIONS AND RECOMMENDATIONS

A summary of the findings of this investigation is as follows:

1. Of the two mirrors, the CERVIT mirror is heavier by about 7%.
2. The CERVIT mirror, mainly because of its 35% higher modulus of elasticity, is stiffer with respect to unit transverse inertial loads.
3. The stresses in the ULE mirror are less under unit transverse inertial loads.
4. Using nominal as well as "real" thermal expansion coefficients, the ULE mirror generally experiences smaller distortions under unit thermal loads.

It is tempting to ask the following question, "Which mirror performs better?" It is not a question that has a realistic answer, however, given the bounds of this study. If the mirrors had been designed to absolutely the same dimensional and mechanical specifications, and then subjected to the same operational environments, then a statement could be made. Otherwise, it is only reasonable to compare the relative performance of the overall systems, of which the primary mirror is one component. If that is not feasible, then a measure of merit could be the performance of the mirror relative to the error budget allocated to it by the optical systems engineering.

It must be remembered that these mirrors are components of two highly complex and substantially different astronomical telescope satellite systems, and in each case the mirror has been designed to fulfill the needs of quite separate concepts of optical systems engineering. For those reasons, the curvatures of these mirrors differ slightly, the central hole size is different, and the thermal and mechanical environments that each experiences will be determined by system parameters not included in this analysis. These considerations have substantially greater impact on the mirror performance than the differences between the ULE and CERVIT designs determined here.

The recommendations that will be made here refer mainly to the reliability of the performance predictions. To date there has been no significant comparison of measured and predicted mirror displacement and stress performance for either a CERVIT or ULE mirror. This is of vital importance since some unknowns still exist in the modelling. In the ULE mirrors this includes the degree of fusion of ribs to flanges, the dimensions after slump, and the effects of posts and holes in the webs. With CERVIT the uncertainties include the stiffening effects of fillets, "wedge" and the rather variable nature of the thermal expansion coefficient.

The paucity of fracture mechanics data for either CERVIT or ULE makes it impossible to assign tensile working stress values. It is highly recommended that additional tests with appropriately sized samples be performed.

APPENDIX A

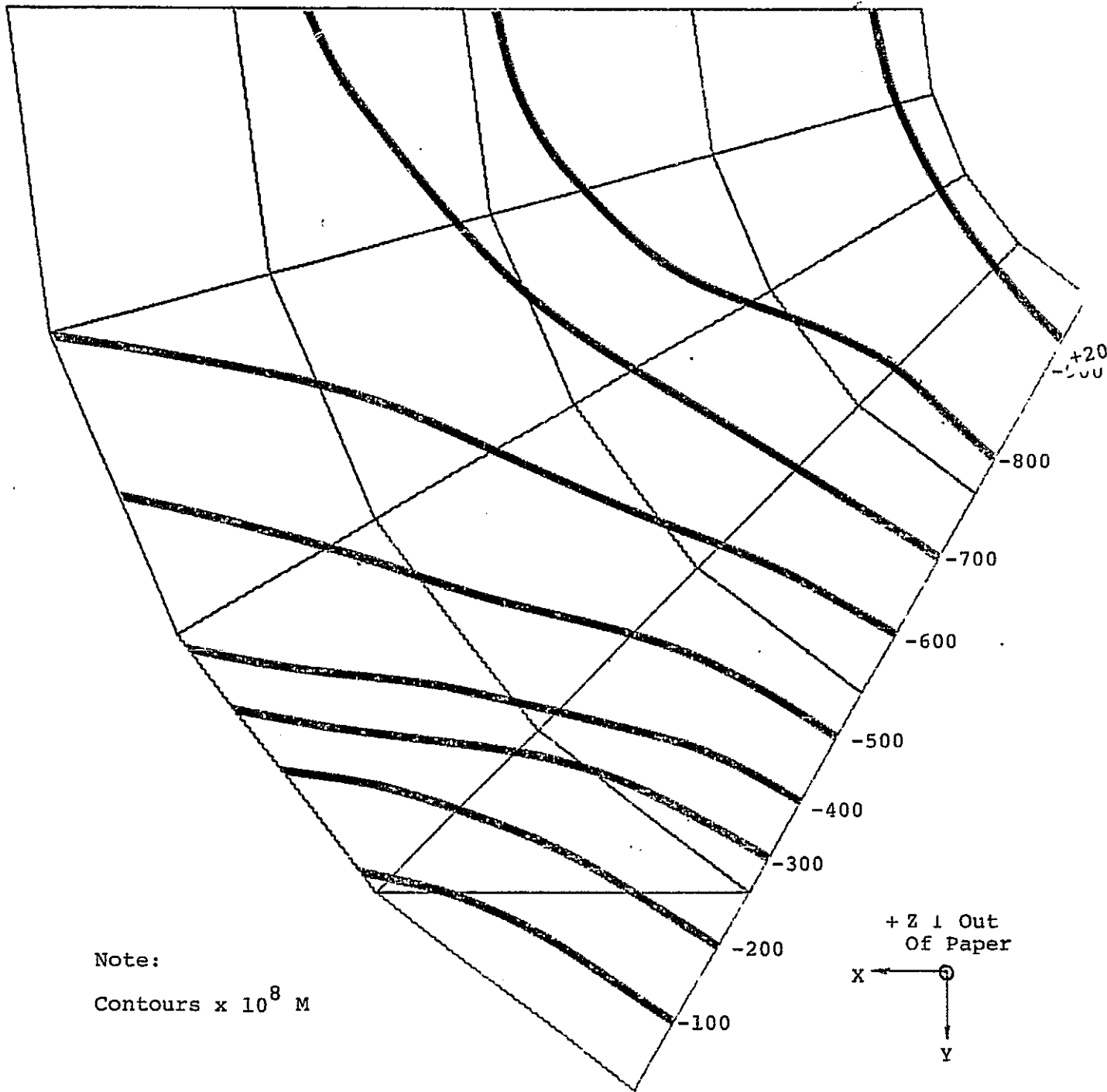

Note:
 Contours x 10^8 M

Figure A.1 Z-Deflection Contours of the Itek Mirror Optical Surface, 1G Load (-Z Direction)

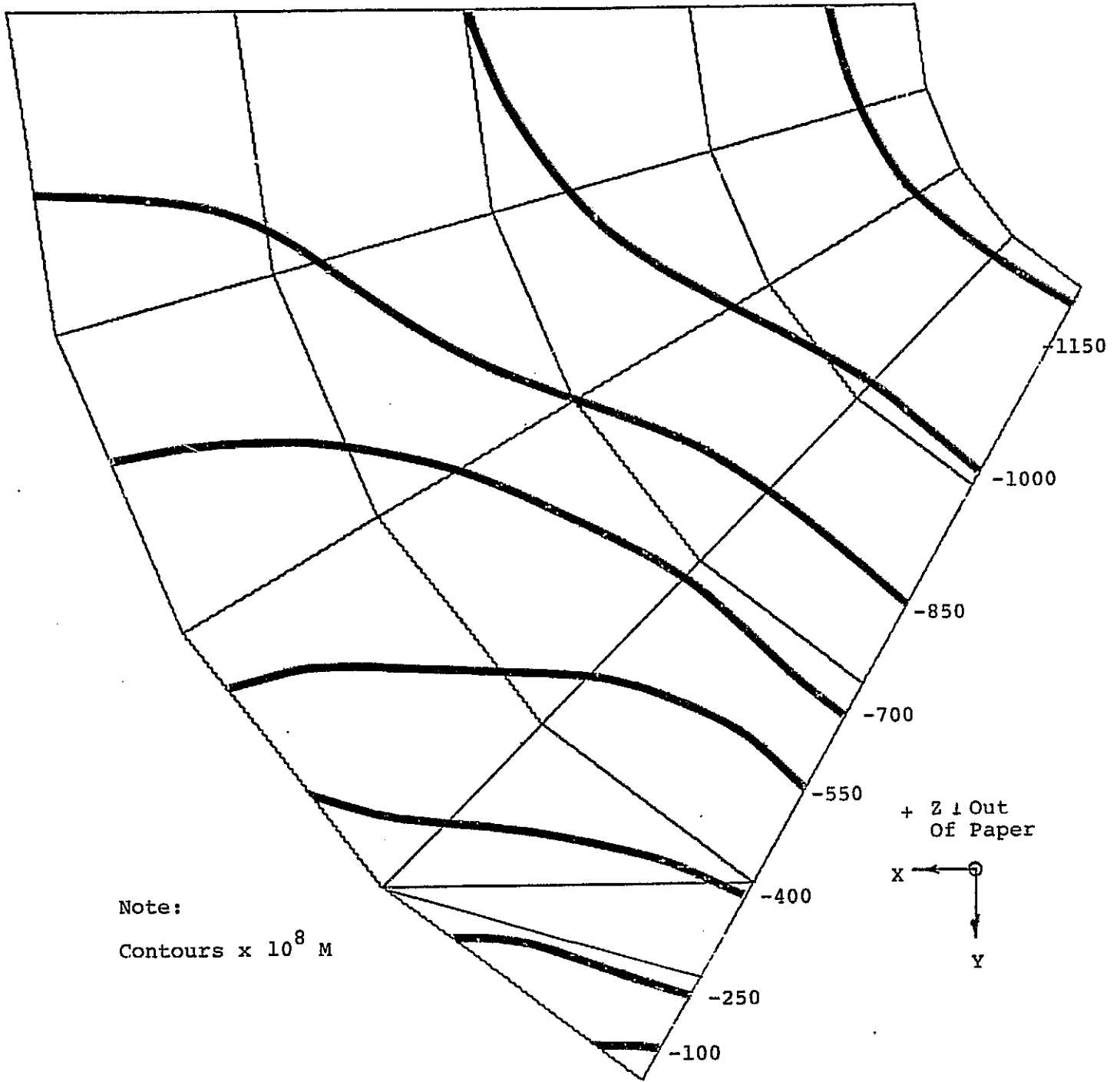

Figure A.2 Z-Deflection Contours of the Perkin-Elmer Mirror Optical Surface, 1G Load (-Z Direction)

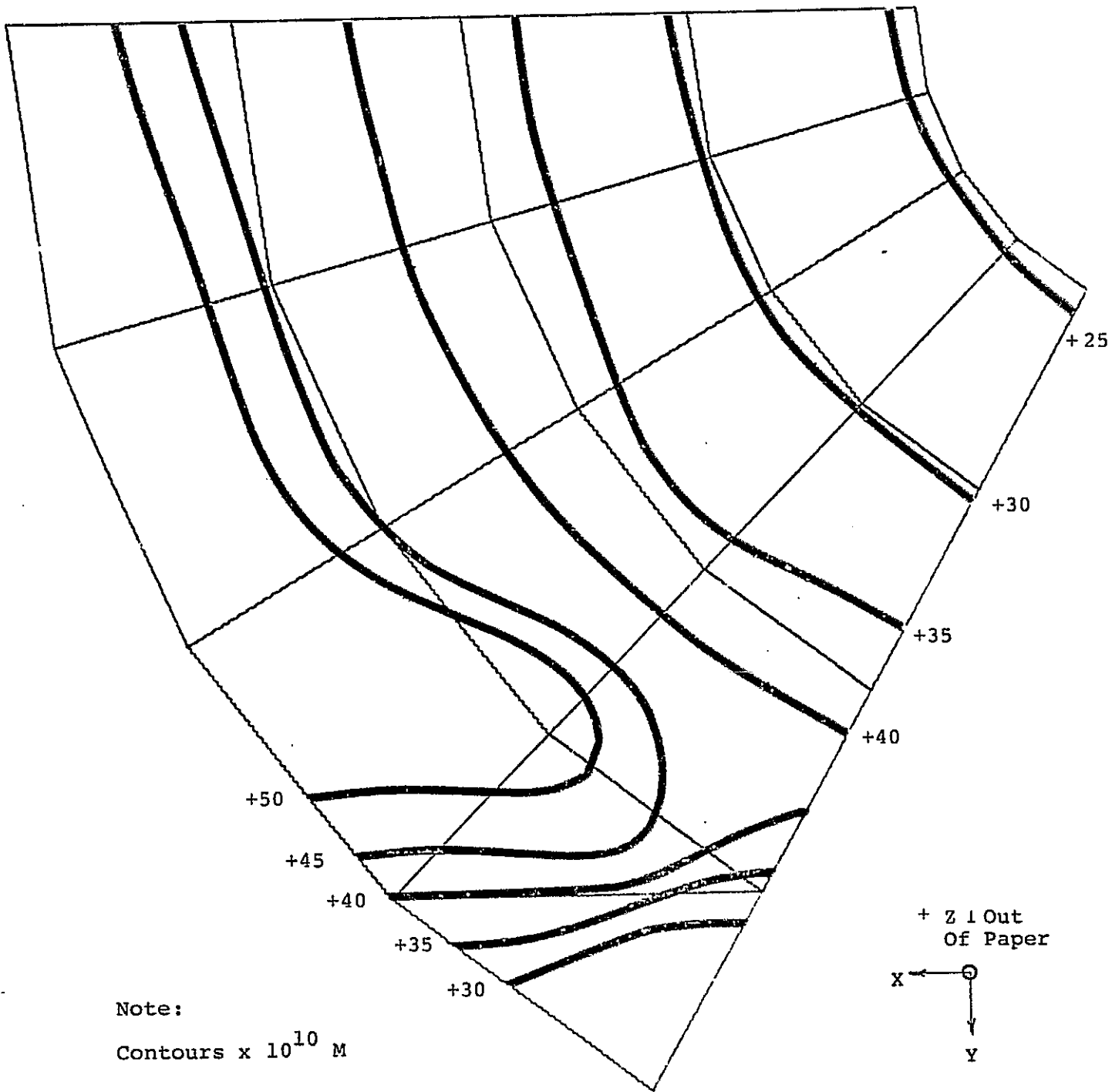
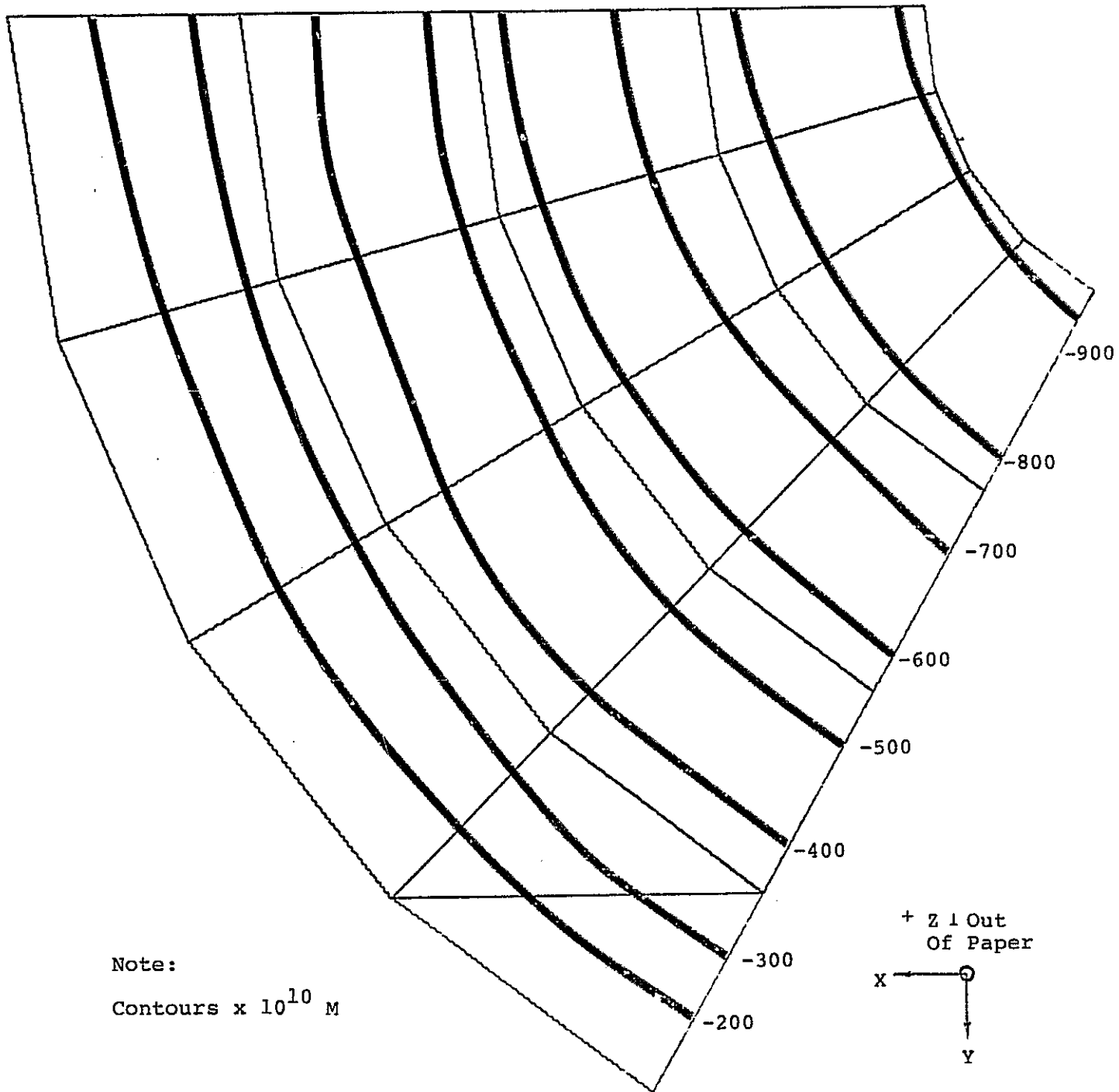
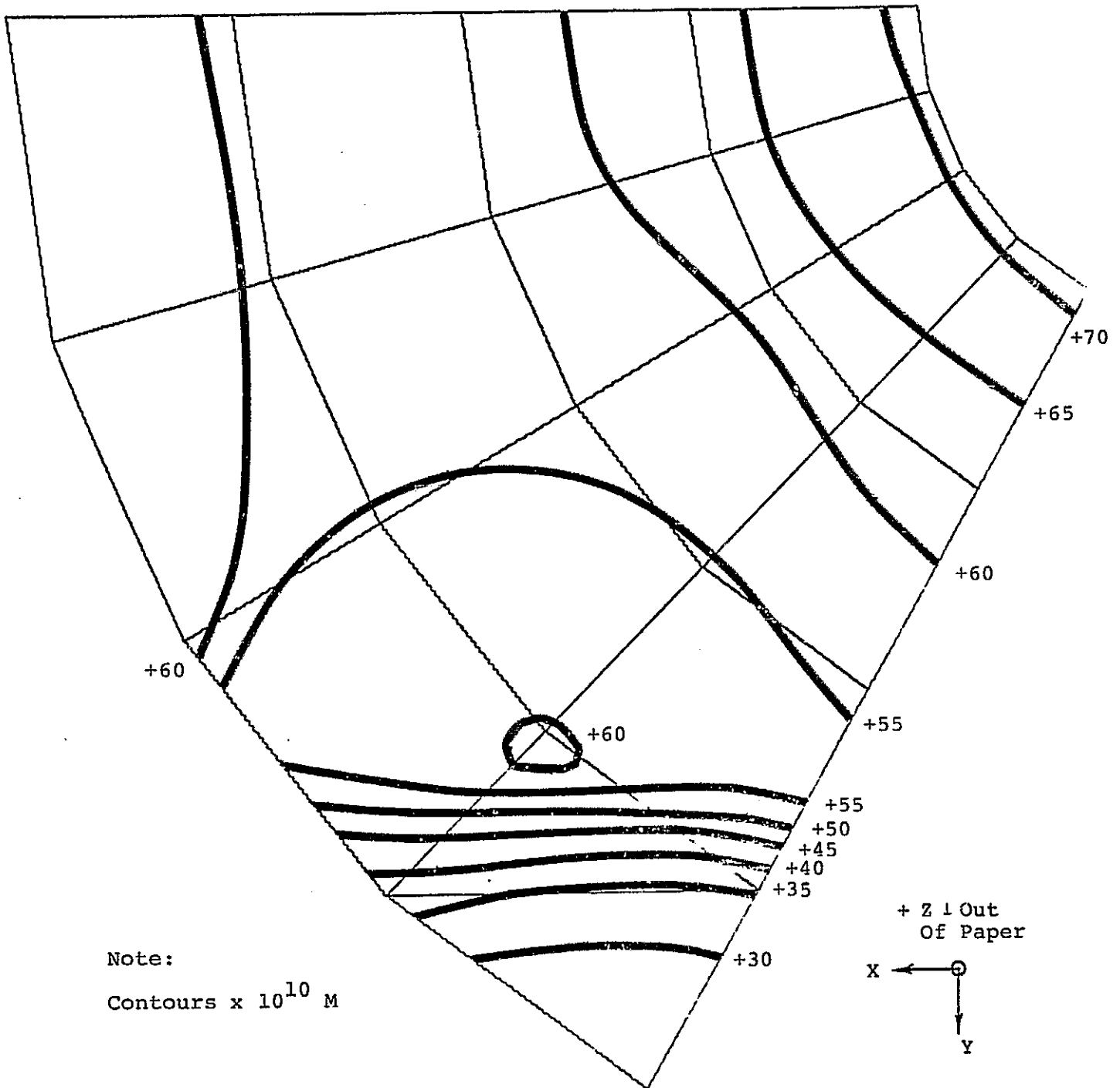

Figure A.3 Z-Deflection Contours of the Itek Mirror Optical Surface, 1°F Soak, Nominal Thermal Coefficient



Note:
Contours x 10^{10} M

Figure A.4 Z-Deflection Contours of the Itek Mirror Optical Surface, 1°F Axial Gradient, Nominal Thermal Coefficient



Note:

Contours $\times 10^{10}$ M

Figure A.5 Z-Deflection Contours of the Itek Mirror Optical Surface, $1/F$ Radial Gradient, Nominal Thermal Coefficient

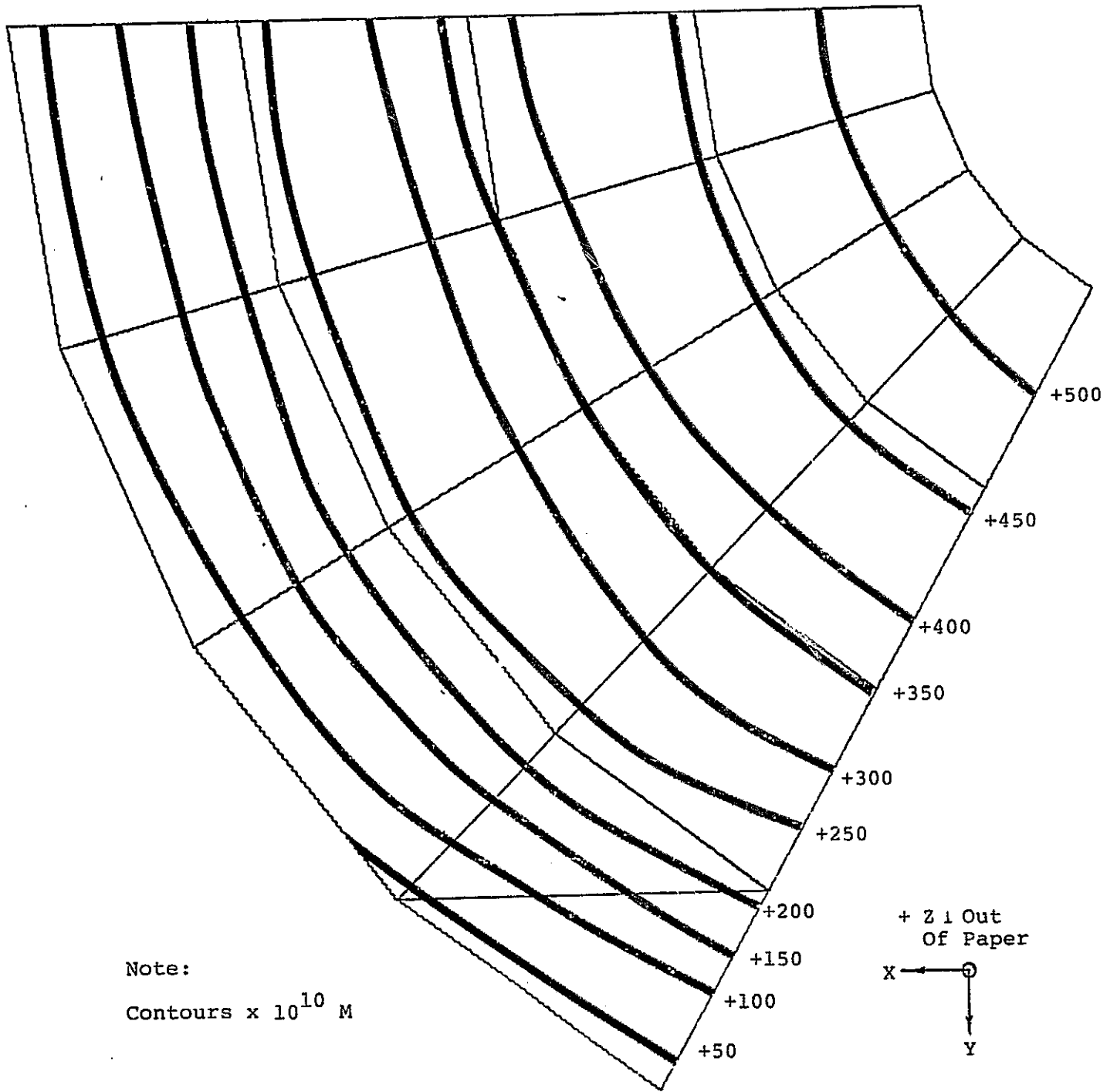
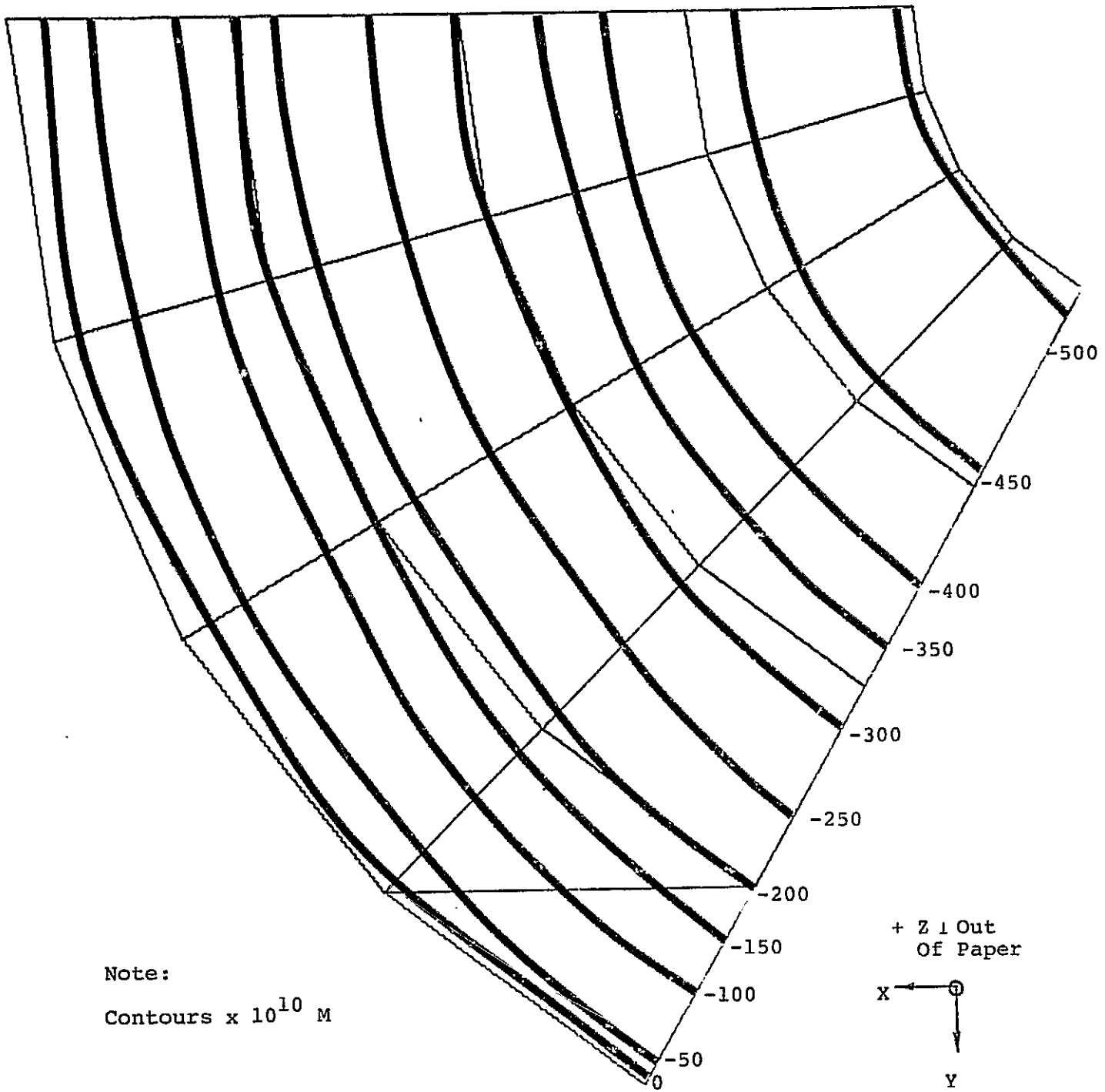

Figure A.6 Z-Deflection Contours of the Itek Mirror Optical Surface, 1°F Soak, Thermal Coefficient @ 10°C



Note:

Contours $\times 10^{10}$ M

Figure A.7 Z-Deflection Contours of the Itek Mirror Optical Surface, 1°F Axial Gradient, Thermal Coefficient @ 10°C

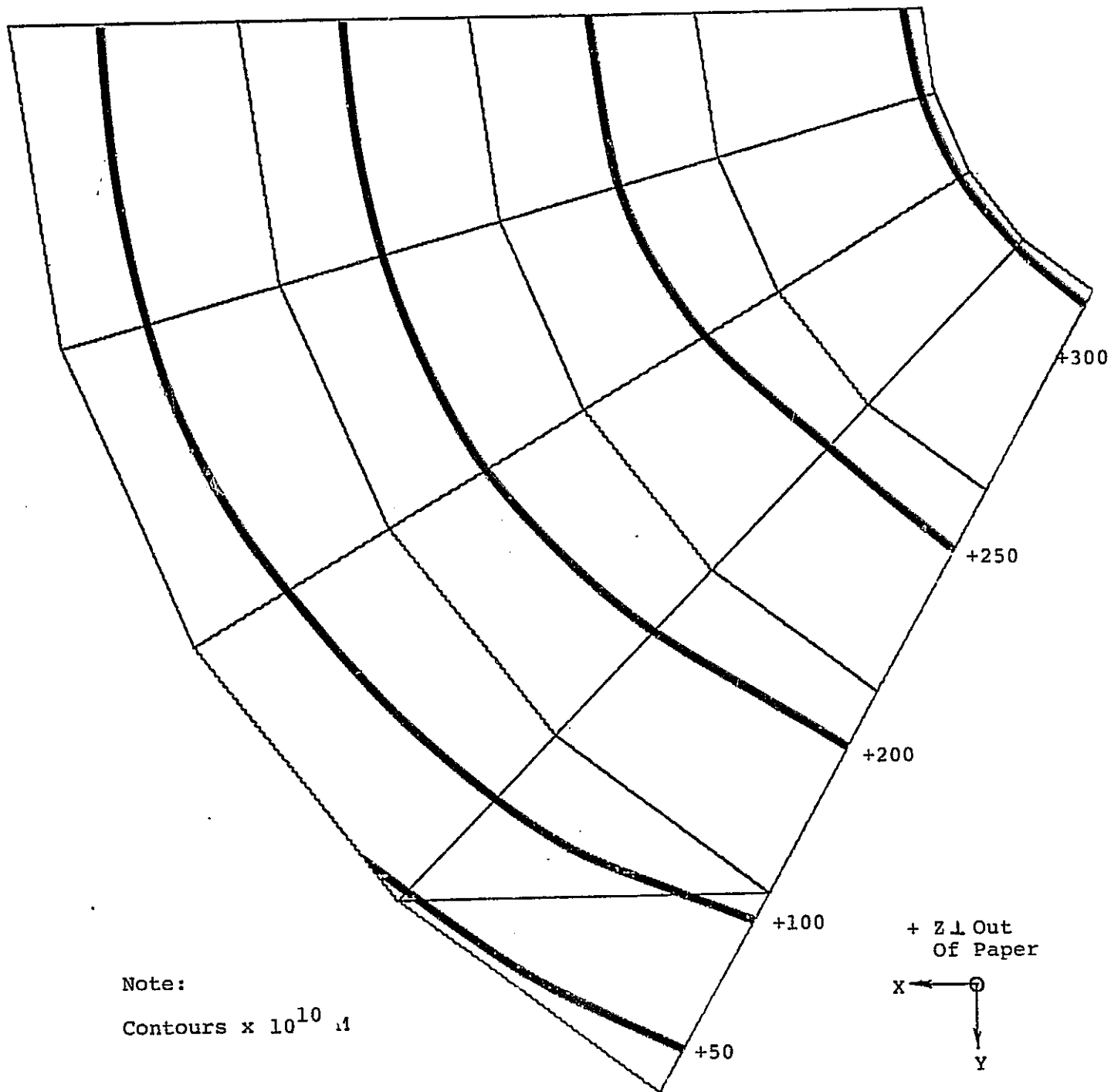

Note:

Contours $\times 10^{10}$ μ

Figure A.8 Z-Deflection Contours of the Itek Mirror Optical Surface, 1°F Radial Gradient, Thermal Coefficient at 10°C

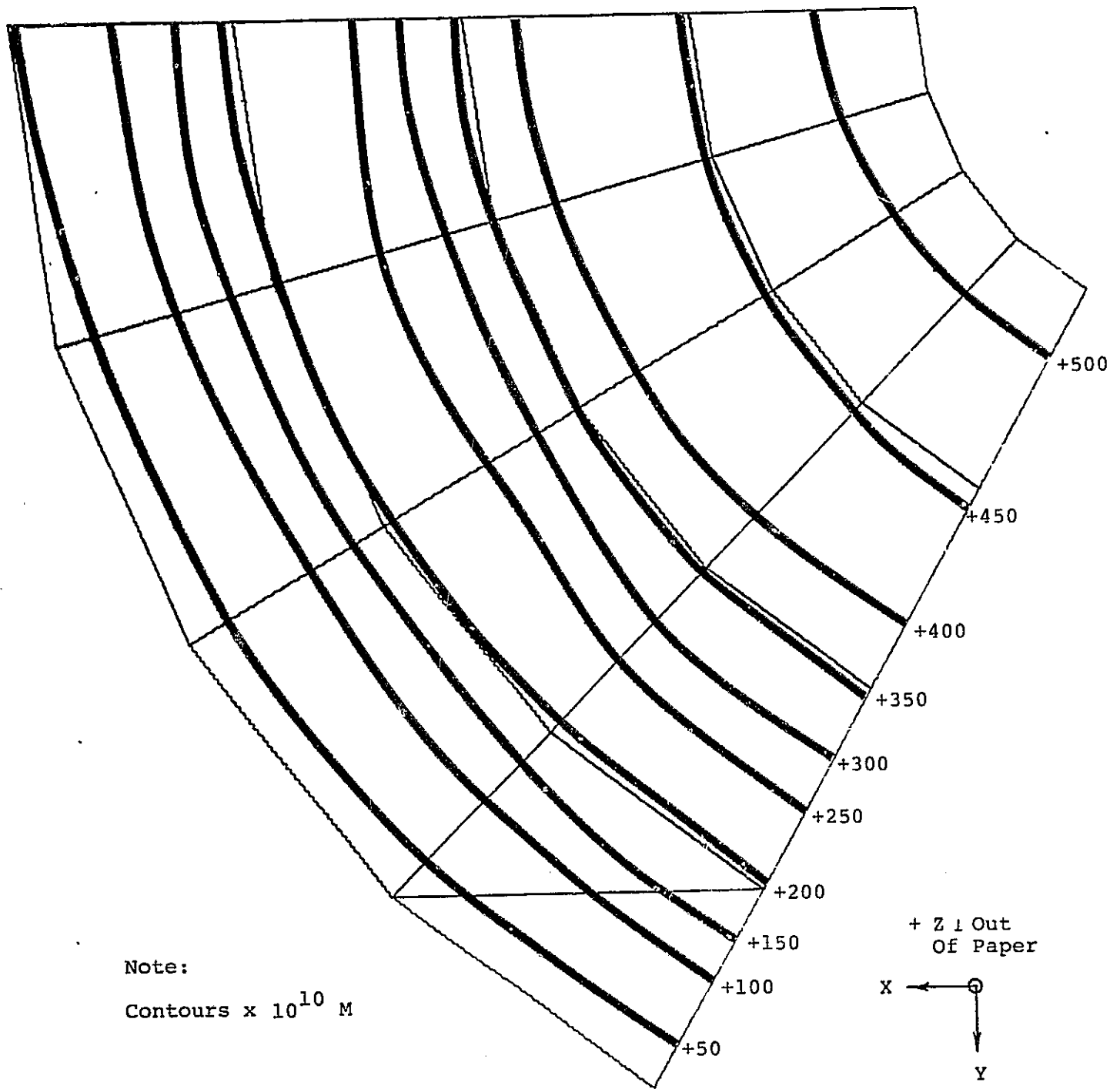

Note:
Contours x 10^{10} M

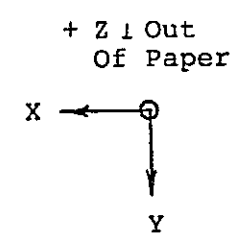

Figure A.9 Z-Deflection Contours of the Itek Mirror Optical Surface, 1°F Soak, Thermal Coefficient @ 15°C

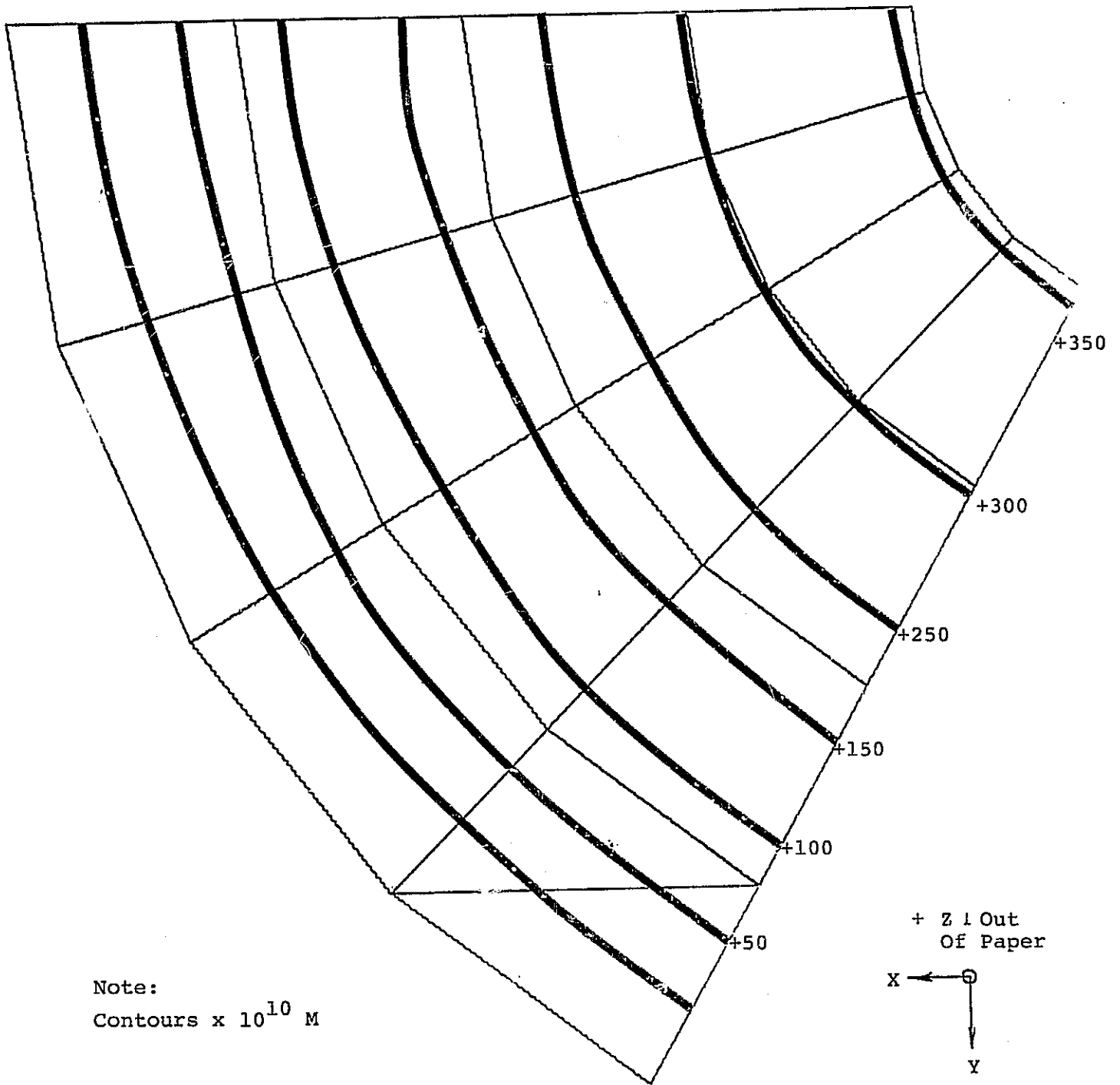

Figure A.10 Z-Deflection Contours of the Itek Mirror Optical Surface, 1° F Axial Gradient, Thermal Coefficient @ 15° C

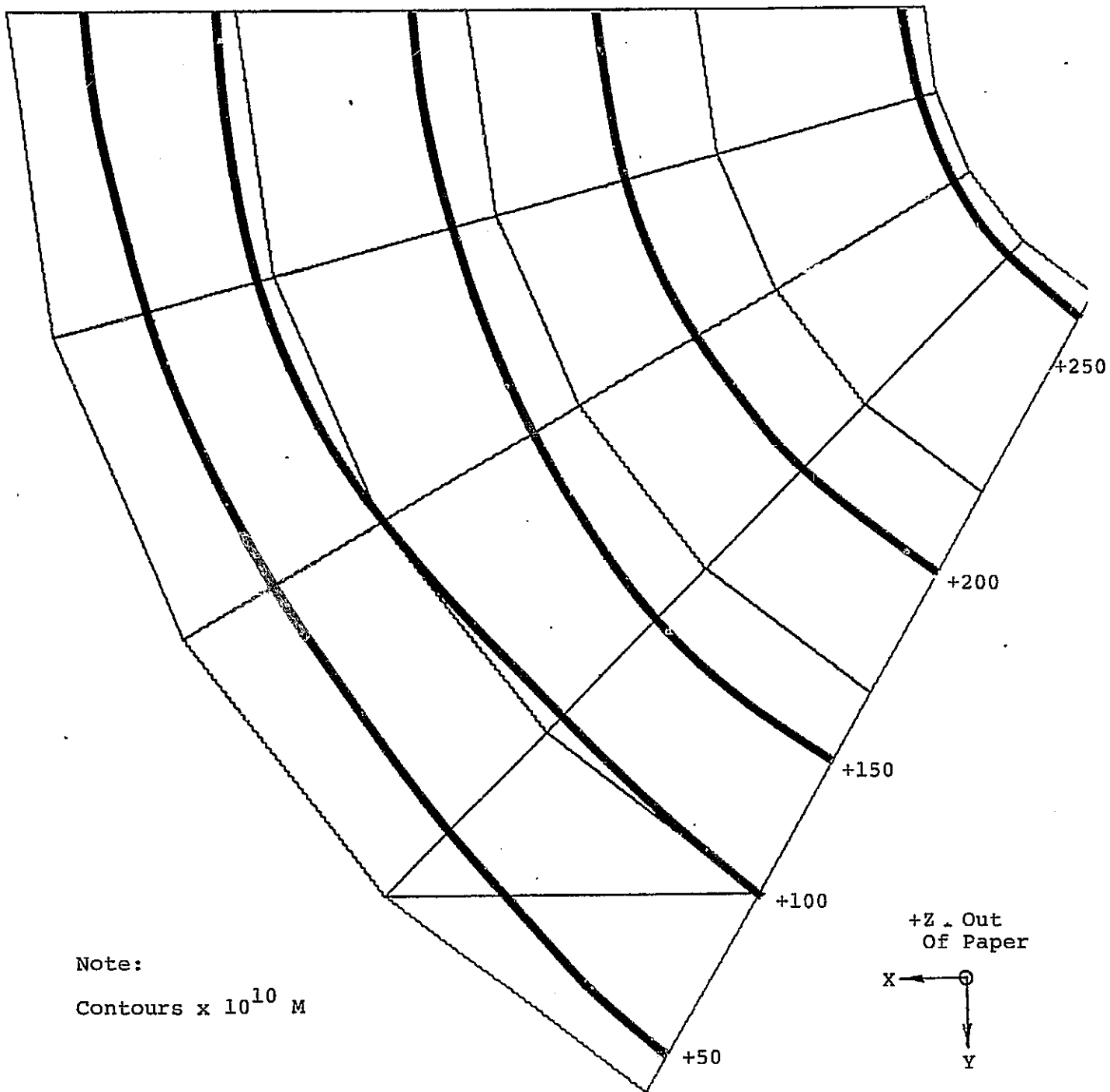

Figure A.11 Z-Deflection Contours of the Itek Mirror Optical Surface, 1°F Radial Gradient, Thermal Coefficient @ 15°C

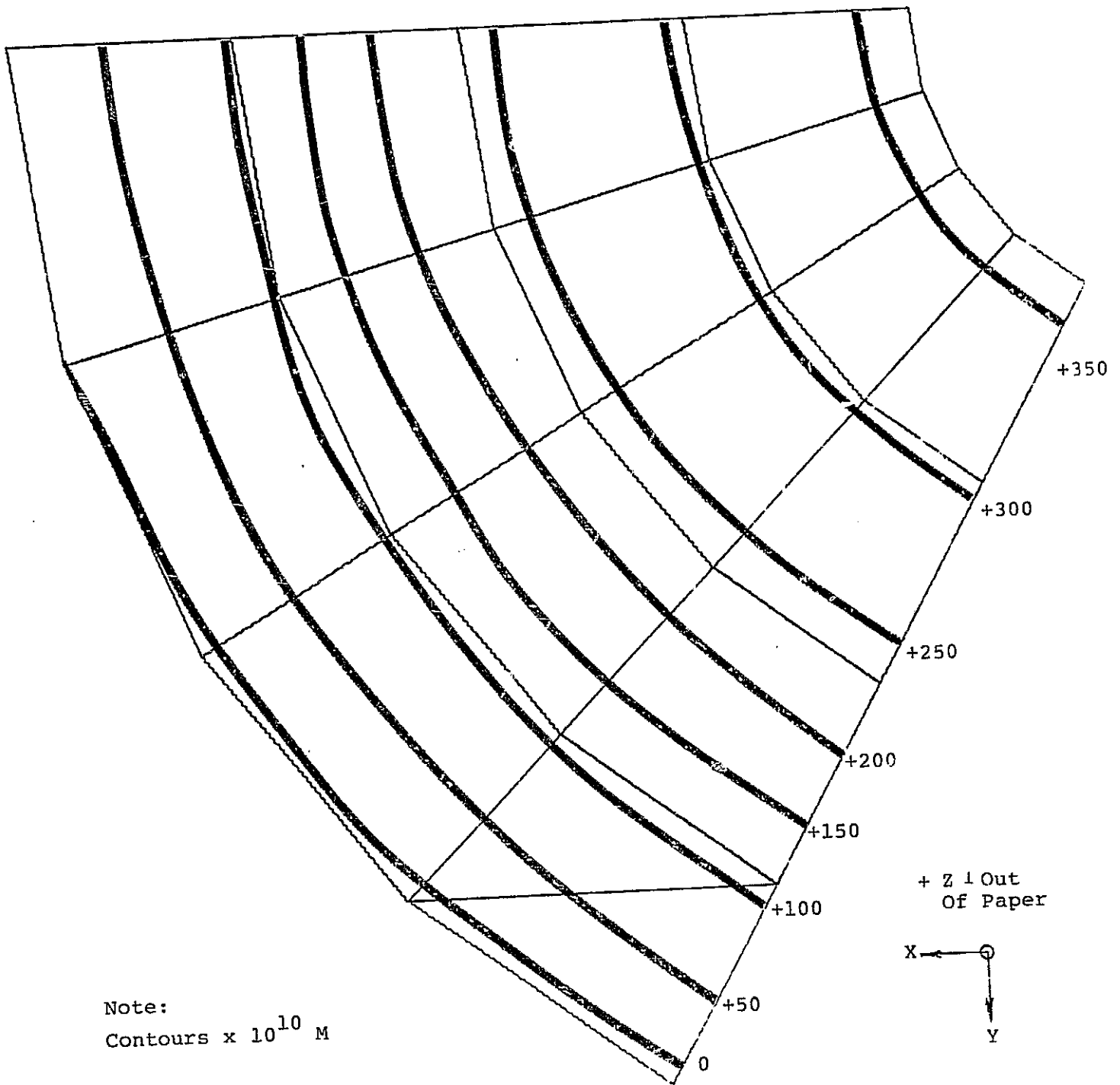
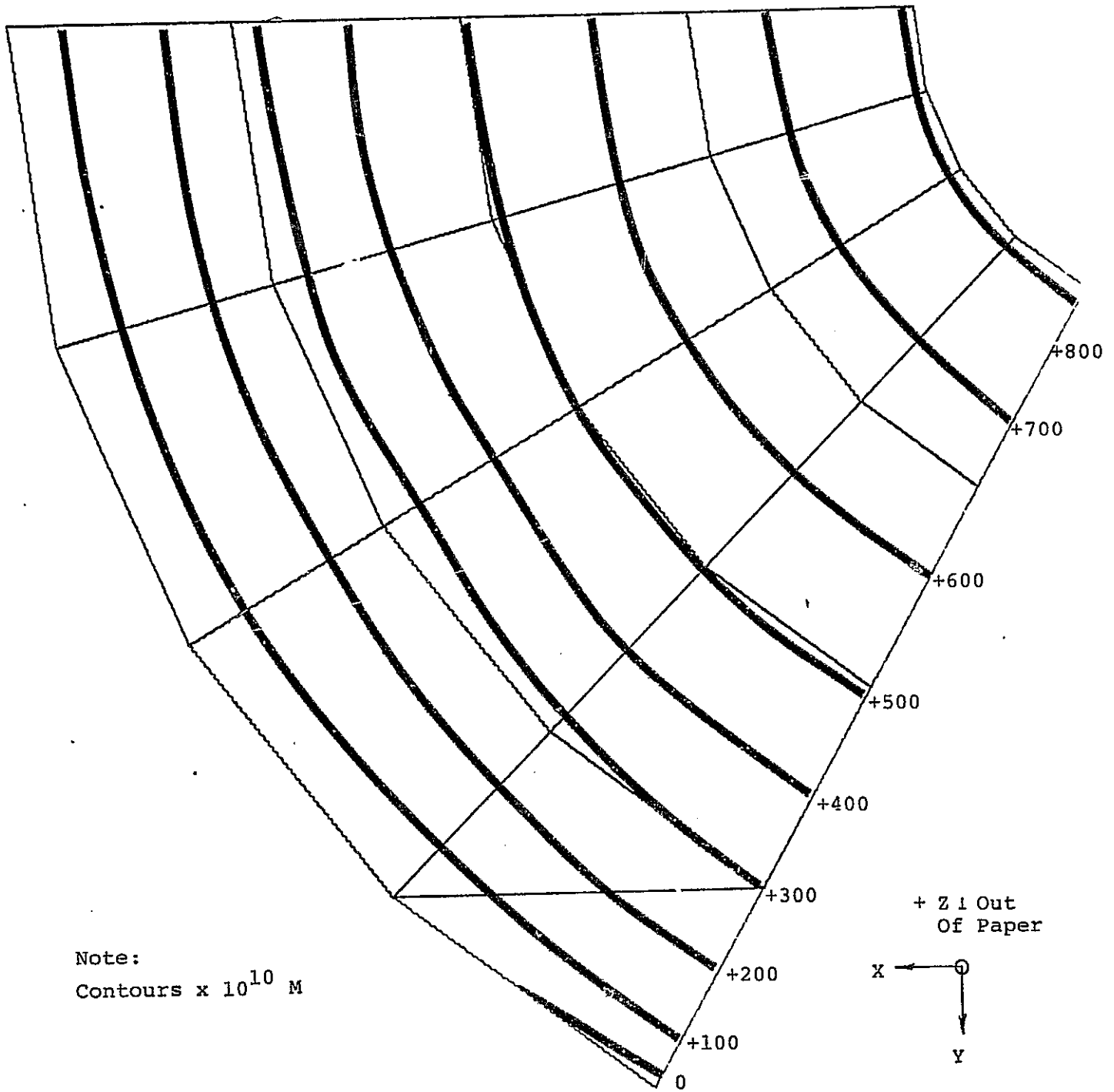

Figure A.12 Z-Deflection Contours of the Itek Mirror Optical Surface, 1^oF Soak, Thermal Coefficient @ 20^oC



Note:
Contours $\times 10^{10}$ M

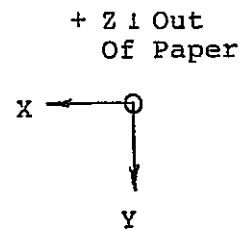
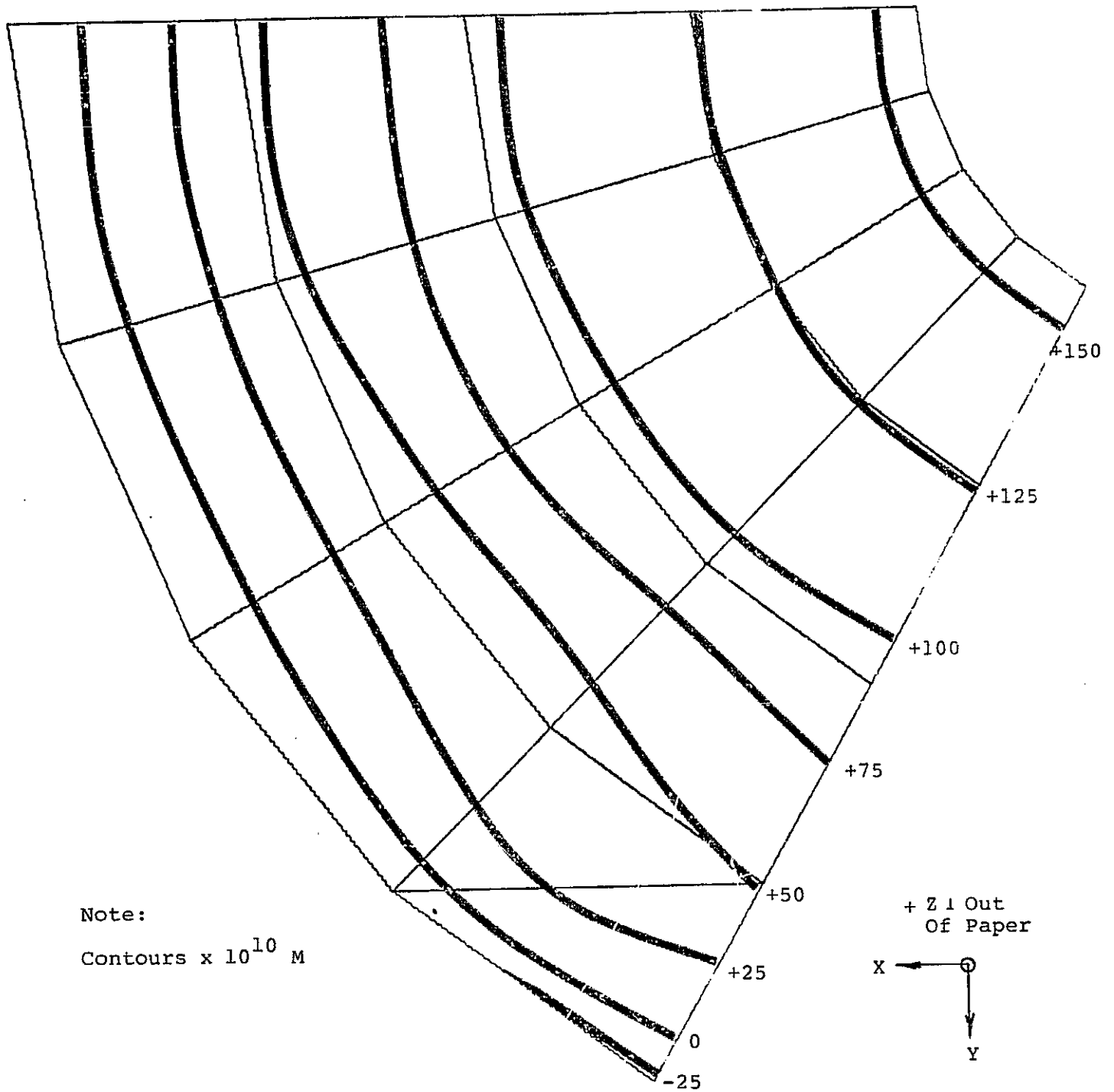

Figure A.13 Z-Deflection Contours of the Itek Mirror Optical Surface, 1°F Axial Gradient, Thermal Coefficient @ 20°C



Note:
Contours x 10^{10} M

Figure A.14 Z-Deflection Contours of the Itek Mirror Optical Surface, 1°F Radial Gradient, Thermal Coefficient @ 20°C

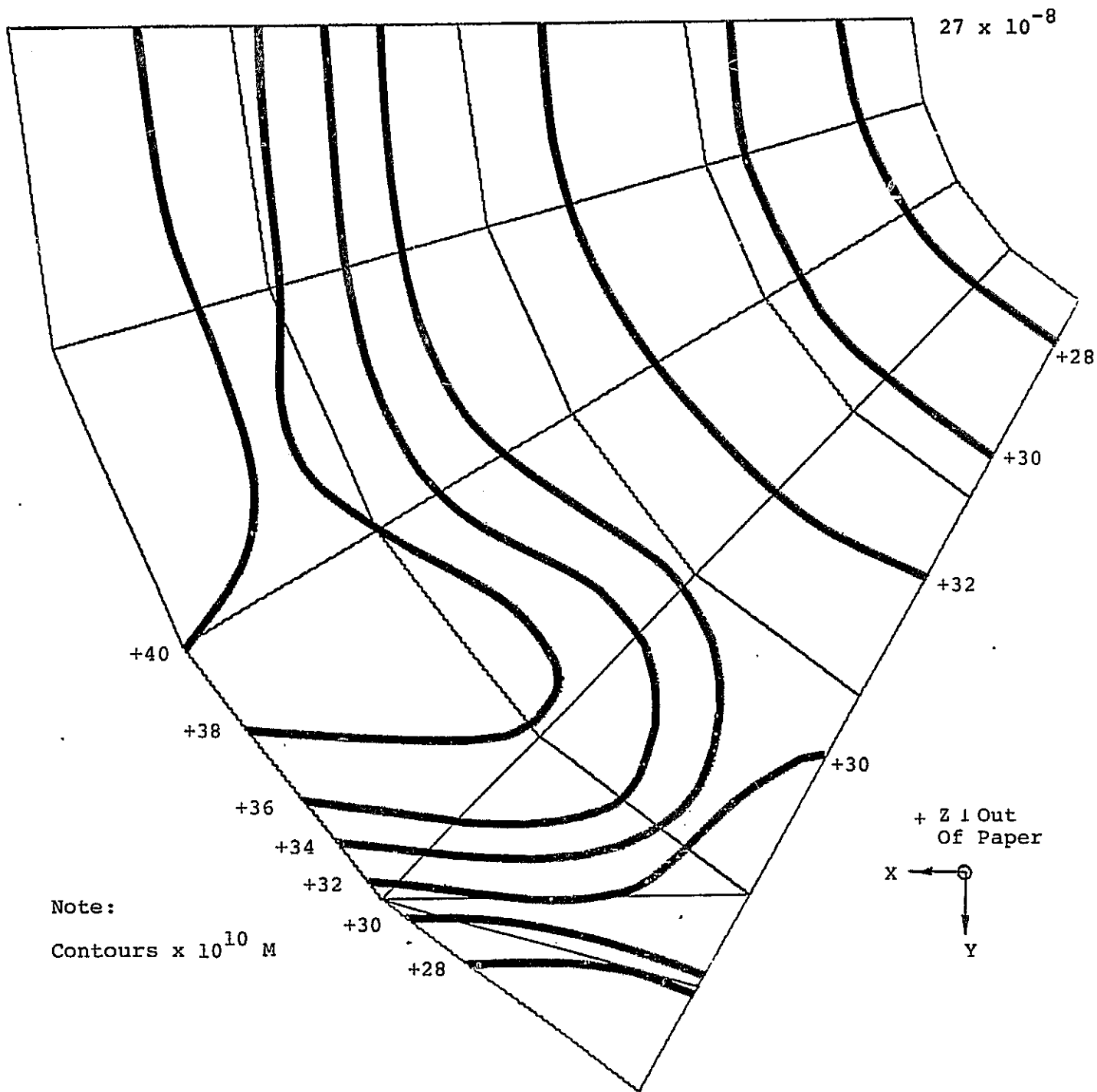

Figure A.15 Z-Deflection Contours of the Perkin-Elmer Mirror Optical Surface, 1 F Soak, Nominal Thermal Coefficient

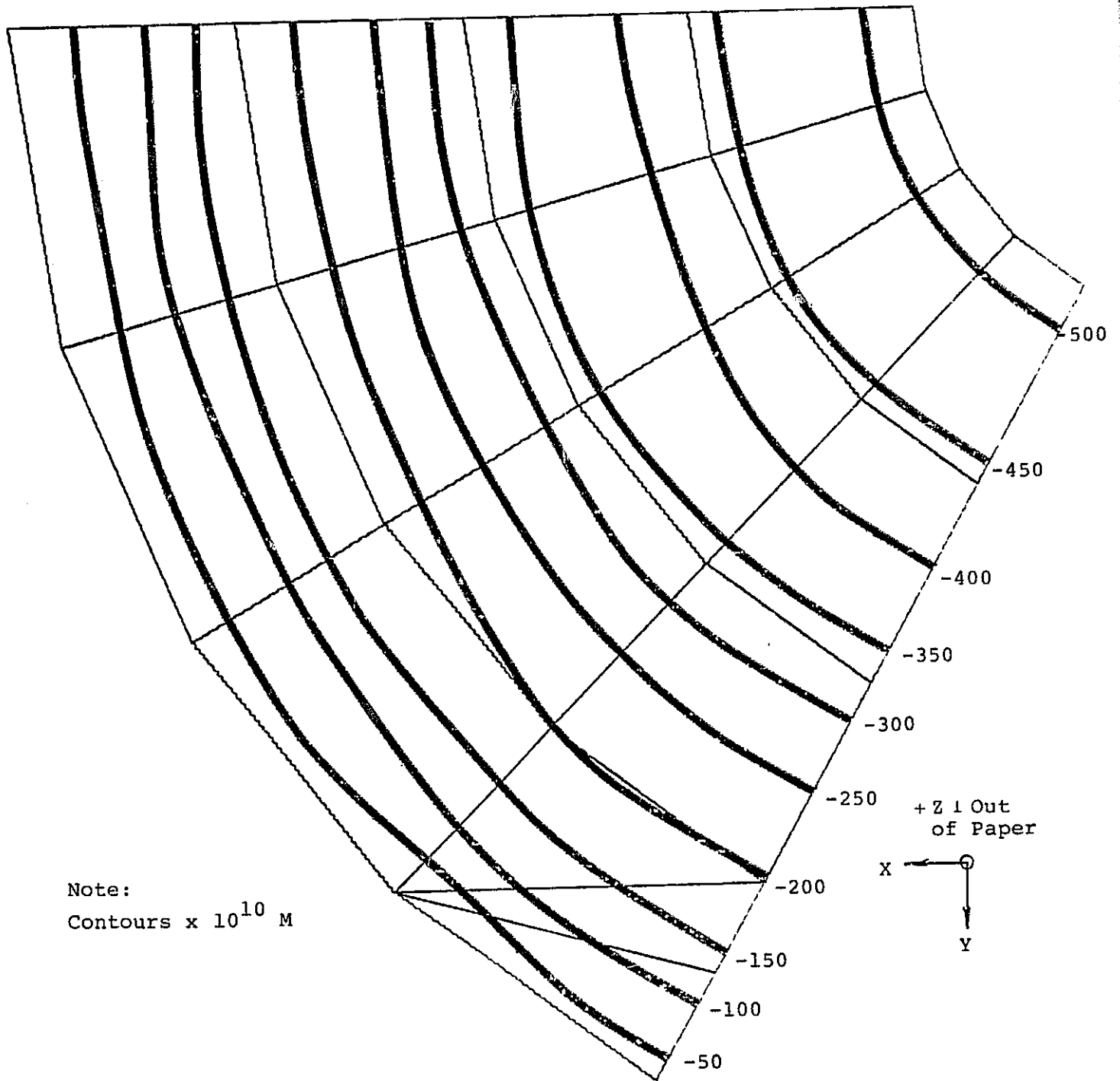
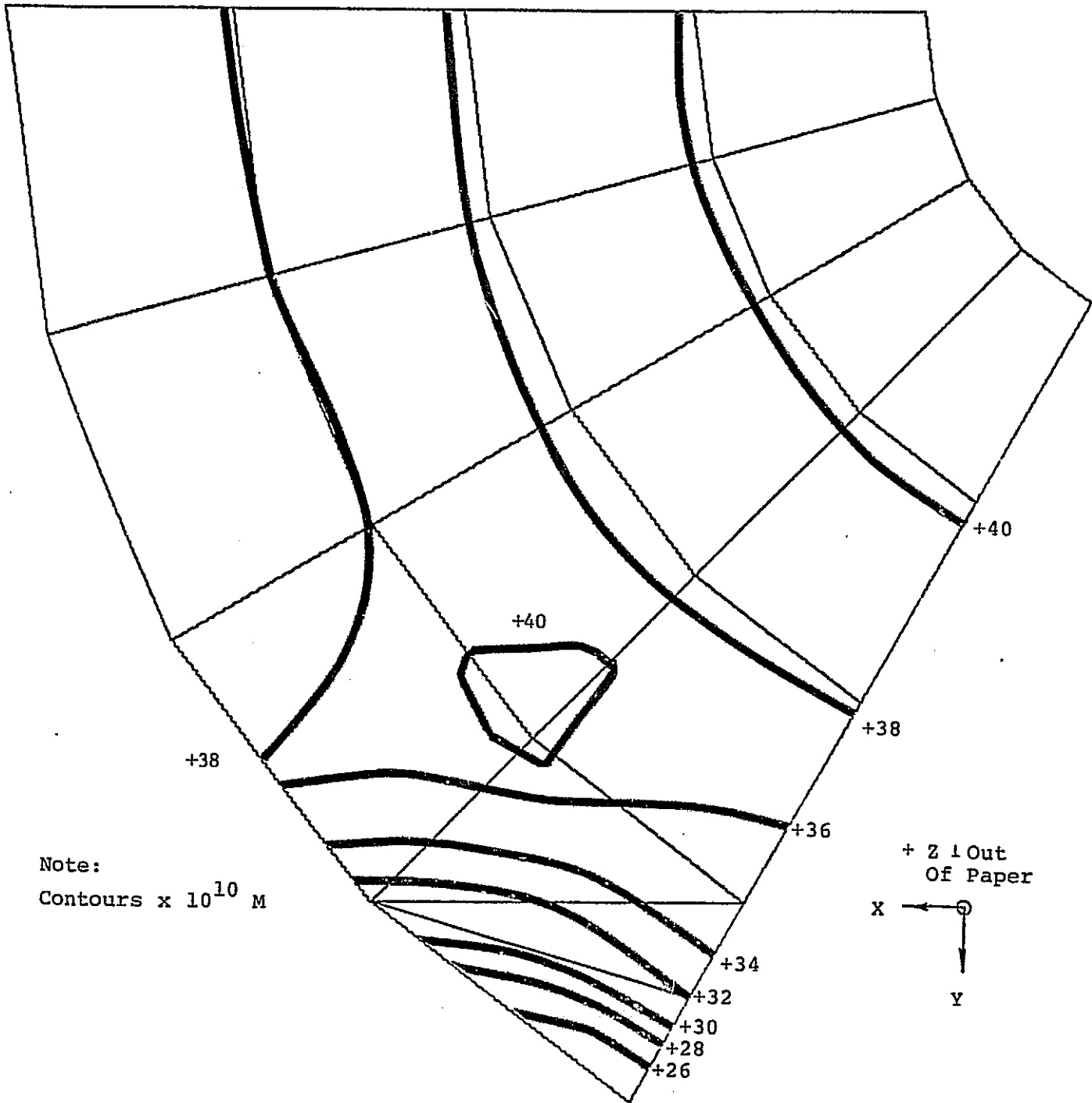

Figure A.16 Z-Deflection Contours of the Perkin-Elmer Mirror Optical Surface, 1°F Axial Gradient, Nominal Thermal Coefficient



Note:
Contours $\times 10^{10}$ M

+ Z \perp Out
Of Paper
X \leftarrow \odot
Y \downarrow

Figure A.17 Z-Deflection Contours of the Perkin-Elmer Mirror Optical Surface, 1° F Radial Gradient, Nominal Thermal Coefficient

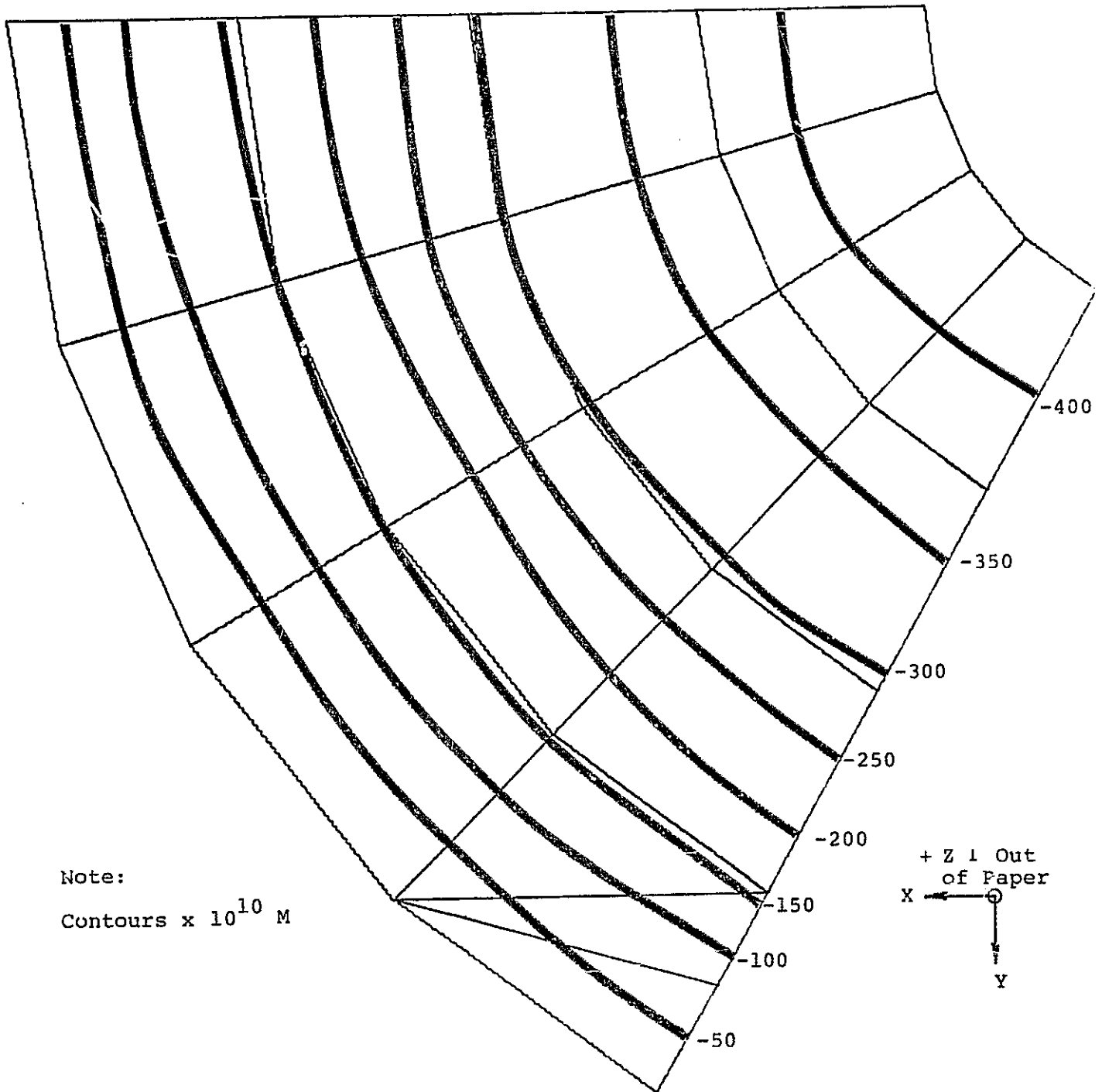

Figure A.18 Z-Deflection Contours of the Perkin-Elmer Mirror Optical Surface, 1°F Soak, Variable Thermal Coefficient

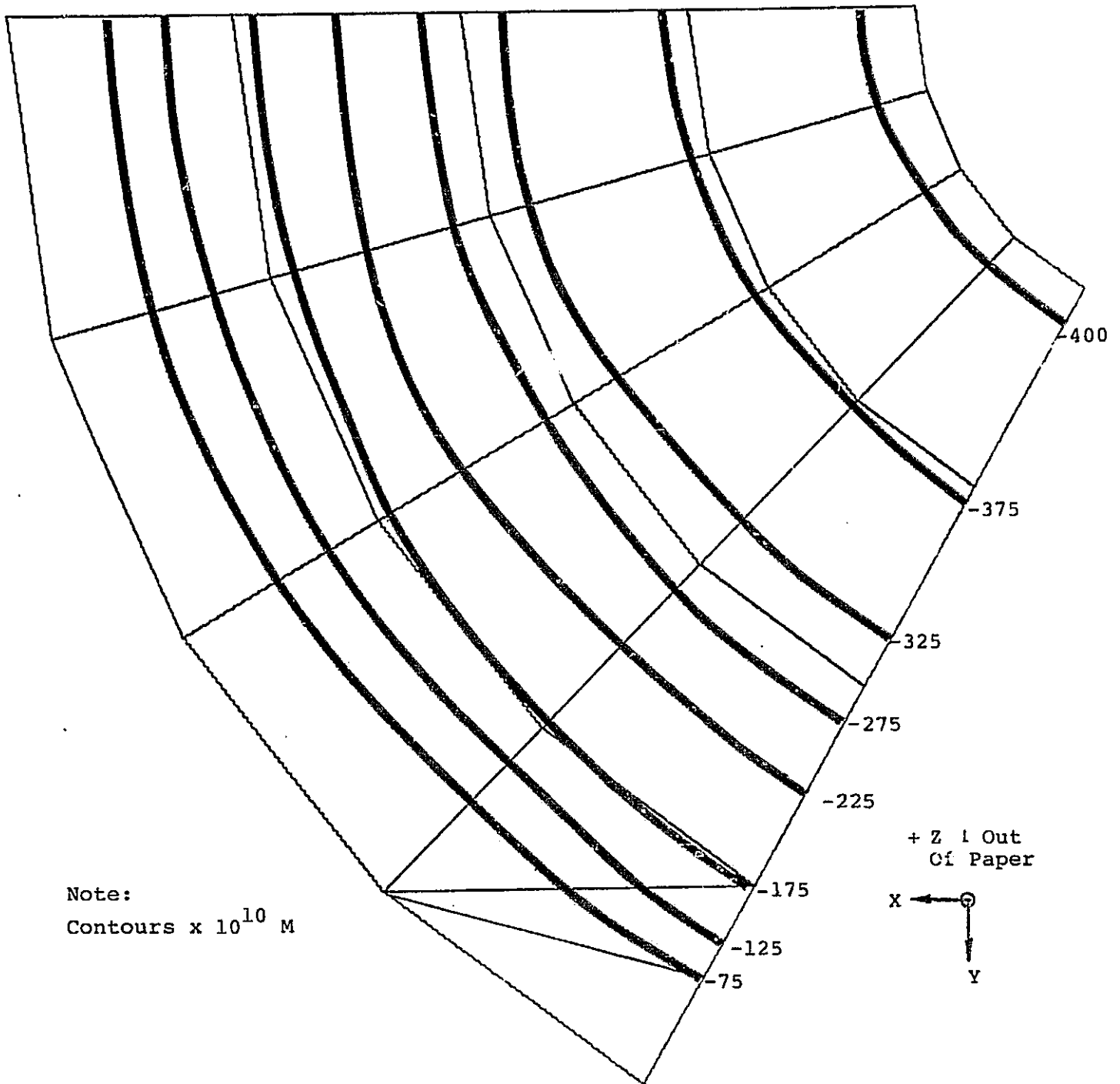
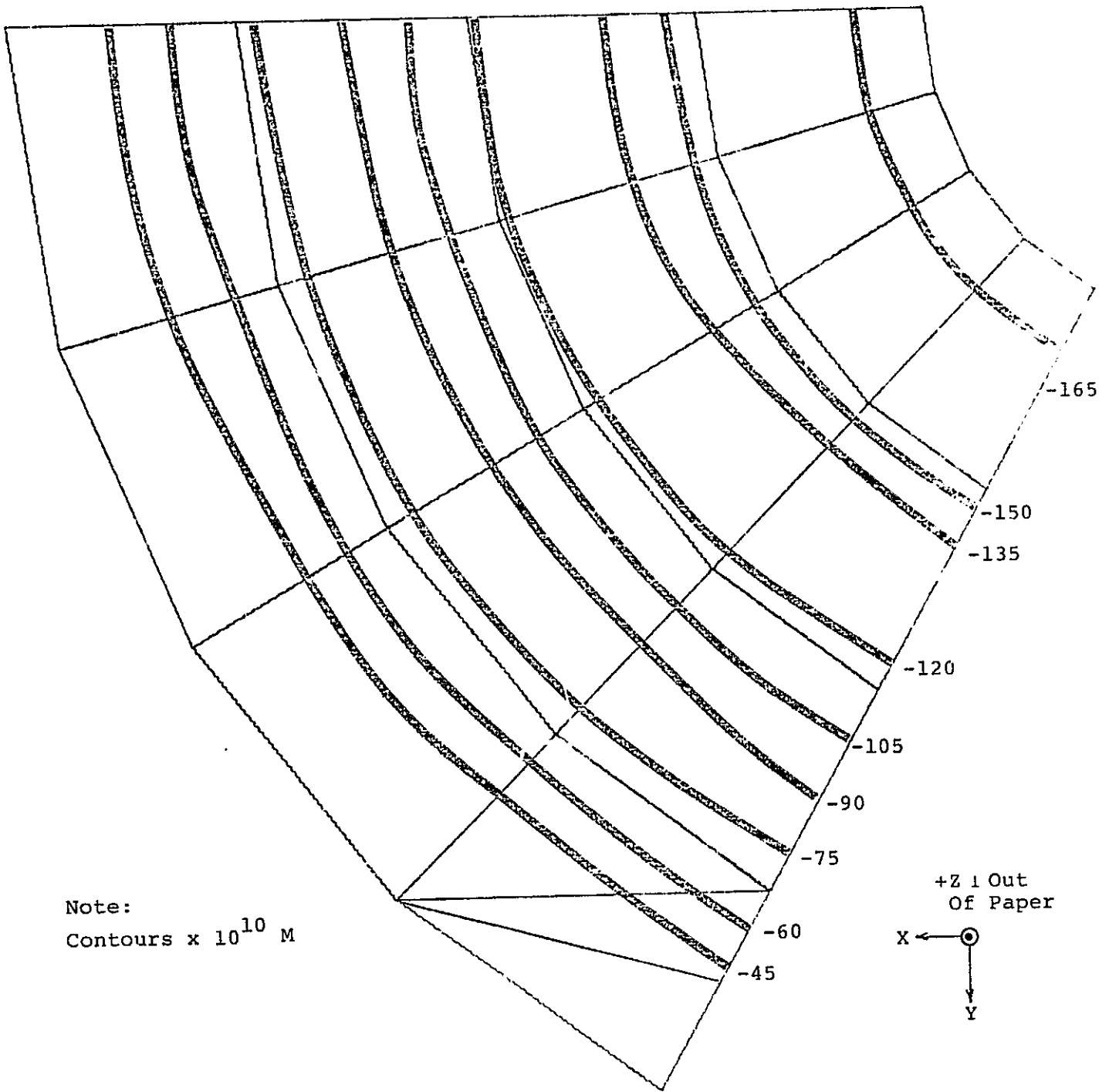

Figure A.19 Z-Deflection Contours of the Perkin-Elmer Mirror Optical Surface, 1°F Axial Gradient, Variable Thermal Coefficient



Note:
Contours x 10^{10} M

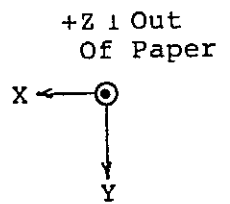

Figure A.20 Z-Deflection Contours of the Perkin-Elmer Mirror Optical Surface, 1° F Radial Gradient, Variable Thermal Coefficient

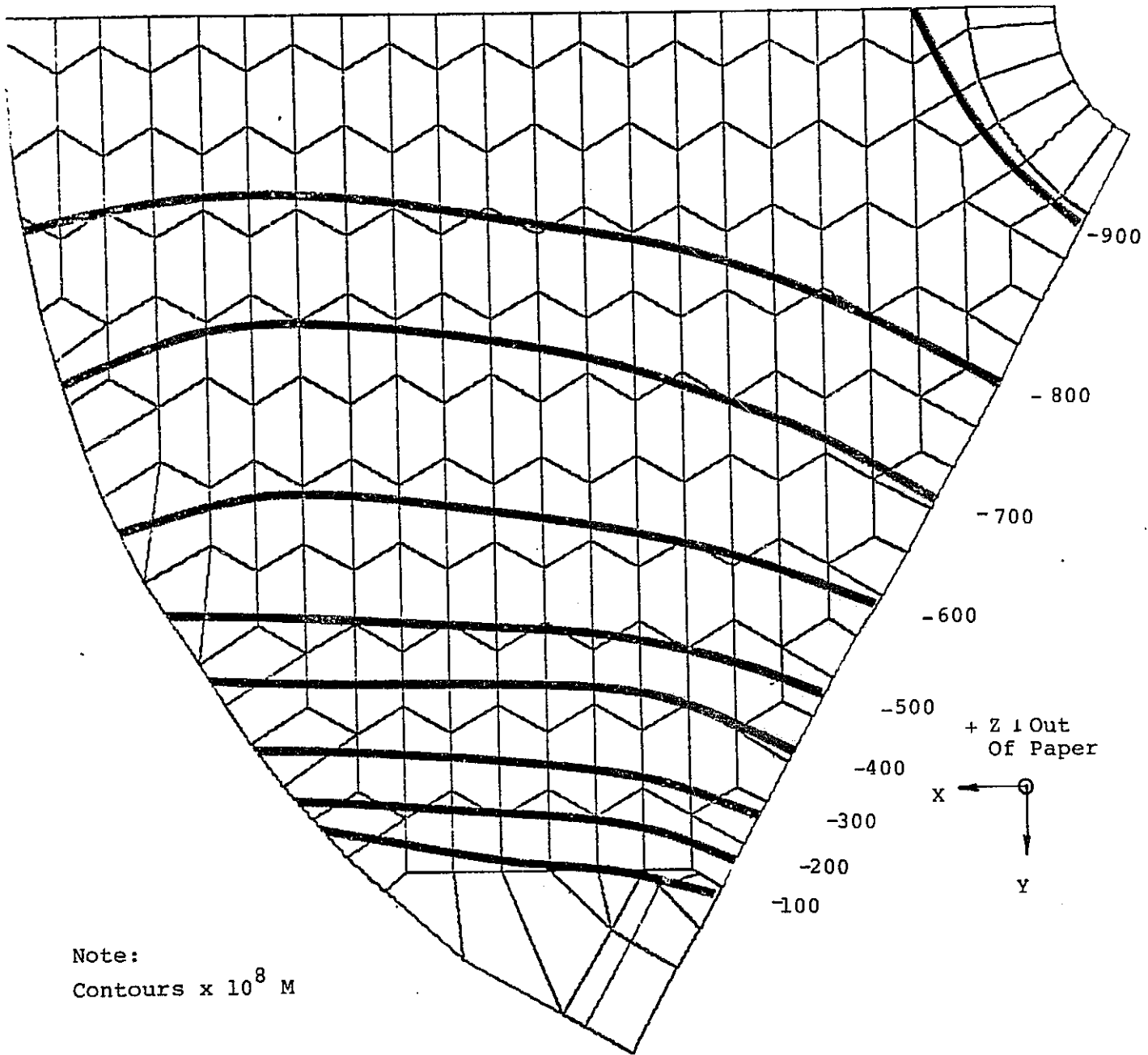

Figure A.21 Z-Deflection Contours of the Boeing Mirror Optical Surface, 1γ Transverse (-Z Direction)

APPENDIX B

The flexibility matrices of the Itek and Perkin-Elmer mirrors have been computed and are listed below. Refer to Figures 2.3 and 2.4 for topology and joint numbering.

While it is of interest to know the mirror displacements everywhere on the reflecting surface, it is not possible to place actuators at all locations on the back surface. (Note that with these thick mirrors, the concept of a neutral surface as in a plate or shell does not apply.) Thus actuator positions are not considered at the inner and outer peripheries of the mirror, or at the immediate support locations. Therefore, displacements are obtained at 120 nodes, but actuators are located at 69 nodes.

The listing on the following pages have nine columns in three groups of three. In each group:

- 1st column is the displacement location
- 2nd column is the actuator location
- 3rd column is the element of the flexibility matrix

The magnitude of the flexibility elements are:

- a. to get inches/pound multiply element listed by 10^{-6}
- b. to get meters/Newton multiply element listed by 5.71×10^{-9}

Both flexibility matrices (Itek and Perkin-Elmer) are also available in form of punched cards and may be obtained upon request from Charles Stark Draper Lab., Inc., in Cambridge, Massachusetts 02139.

LISTING OF THE FLEXIBILITY MATRIX
OF THE ITEK MIRROR

1	2	0.108968E 01	1	3	0.808442E 00	1	4	0.583088E 00
1	7	0.994030E 00	1	8	0.759242E 00	1	9	0.556936E 00
1	12	0.767186E 00	1	13	0.625504E 00	1	14	0.485399E 00
1	17	0.493869E 00	1	18	0.447980E 00	1	19	0.384756E 00
1	23	0.269392E 00	1	24	0.275176E 00	1	27	0.383701E-01
1	28	0.118239E 00	1	29	0.174511E 00	1	32	-0.914114E-01
1	37	0.981710E-02	1	34	0.939088E-01	1	37	-0.158778E 00
1	40	-0.557527E-01	1	39	0.377959E-01	1	42	-0.177234E 00
1	43	-0.845888E-01	1	44	0.473270E-02	1	47	-0.160565E 00
1	48	-0.868629E-01	1	49	-0.104163E-01	1	52	-0.125446E 00
1	53	-0.749349E-01	1	54	-0.142516E-01	1	57	-0.934151E-01
1	58	-0.613071E-01	1	59	-0.133894E-01	1	63	-0.557261E-01
1	64	-0.125201E-01	1	67	-0.934623E-01	1	68	-0.613513E-01
1	69	-0.134344E-01	1	72	-0.125576E 00	1	73	-0.750625E-01
1	74	-0.143232E-01	1	77	-0.160730E 00	1	78	-0.869861E-01
1	79	-0.104920E-01	1	82	-0.177237E 00	1	83	-0.845910E-01
1	84	0.473130E-02	1	87	-0.158762E 00	1	88	-0.557187E-01
1	89	0.378539E-01	1	92	-0.913933E-01	1	93	0.981440E-02
1	94	0.939797E-01	1	97	0.384398E-01	1	98	0.118295E 00
1	99	0.174545E 00	1	103	0.269520E 00	1	104	0.275177E 00
1	107	0.493956E 00	1	108	0.448034E 00	1	109	0.384784E 00
1	112	0.767229E 00	1	113	0.625463E 00	1	114	0.485480E 00
1	117	0.994001E 00	1	118	0.759272E 00	1	119	0.556992E 00
2	2	0.901787E 00	2	3	0.708097E 00	2	4	0.527841E 00
2	7	0.825570E 00	2	8	0.658548E 00	2	9	0.507376E 00
2	12	0.639971E 00	2	13	0.546364E 00	2	14	0.447595E 00
2	17	0.425578E 00	2	18	0.402555E 00	2	19	0.364730E 00
2	23	0.260128E 00	2	24	0.275650E 00	2	27	0.677567E-01
2	28	0.140518E 00	2	29	0.194396E 00	2	32	-0.314999E-01
2	33	0.554075E-01	2	34	0.129352E 00	2	37	-0.830064E-01
2	38	0.348490E-02	2	39	0.836582E-01	2	42	-0.986175E-01
2	43	-0.206643E-01	2	44	0.558736E-01	2	47	-0.889097E-01
2	48	-0.250261E-01	2	49	0.419755E-01	2	52	-0.662281E-01
2	53	-0.188150E-01	2	54	0.370320E-01	2	57	-0.457043E-01
2	58	-0.107414E-01	2	59	0.362869E-01	2	63	-0.737300E-02
2	64	0.364363E-01	2	67	-0.457244E-01	2	68	-0.107671E-01
2	69	0.362536E-01	2	72	-0.663080E-01	2	73	-0.188509E-01
2	74	0.369837E-01	2	77	-0.890137E-01	2	78	-0.251037E-01
2	79	0.419292E-01	2	82	-0.986202E-01	2	83	-0.206662E-01
2	84	0.558724E-01	2	87	-0.830281E-01	2	88	0.348970E-02
2	89	0.836936E-01	2	92	-0.315141E-01	2	93	0.553867E-01
2	94	0.129403E 00	2	97	0.677922E-01	2	98	0.140555E 00
2	99	0.194425E 00	2	103	0.260240E 00	2	104	0.275661E 00
2	107	0.425689E 00	2	108	0.402626E 00	2	109	0.364770E 00
2	112	0.640064E 00	2	113	0.546382E 00	2	114	0.447687E 00
2	117	0.825641E 00	2	118	0.658629E 00	2	119	0.507458E 00
3	2	0.714011E 00	3	3	0.607062E 00	3	4	0.499349E 00
3	7	0.654505E 00	3	8	0.575547E 00	3	9	0.473626E 00
3	12	0.524078E 00	3	13	0.474304E 00	3	14	0.421660E 00
3	17	0.361468E 00	3	18	0.363959E 00	3	19	0.353214E 00
3	23	0.255156E 00	3	24	0.282712E 00	3	27	0.974146E-01
3	28	0.165506E 00	3	29	0.219366E 00	3	32	0.276829E-01
3	33	0.102673E 00	3	34	0.168848E 00	3	37	-0.818100E-02
3	38	0.639293E-01	3	39	0.132932E 00	3	42	-0.206554E-01
3	43	0.444160E-01	3	44	0.110097E 00	3	47	-0.173850E-01
3	48	0.381415E-01	3	49	0.973333E-01	3	52	-0.660860E-02
3	53	0.389322E-01	3	54	0.912745E-01	3	57	0.273980E-02

3	58	0.415633E-01	3	59	0.889475E-01	3	63	0.427795E-01
3	64	0.883880E-01	3	67	0.273650E-02	3	68	0.415480E-01
3	69	0.889201E-01	3	72	-0.665920E-02	3	73	0.389131E-01
3	74	0.912389E-01	3	77	-0.174550E-01	3	78	0.380891E-01
3	79	0.973027E-01	3	82	-0.206575E-01	3	83	0.444144E-01
3	84	0.110096E 00	3	87	-0.822450E-02	3	88	0.639105E-01
3	89	0.132941E 00	3	92	0.276486E-01	3	93	0.102635E 00
3	94	0.168872E 00	3	97	0.974203E-01	3	98	0.165522E 00
3	99	0.219379E 00	3	102	0.255238E 00	3	104	0.282711E 00
3	107	0.361580E 00	3	108	0.364021E 00	3	109	0.353234E 00
3	112	0.524178E 00	3	113	0.474338E 00	3	114	0.421725E 00
3	117	0.654596E 00	3	118	0.575622E 00	3	119	0.473687E 00
4	2	0.528637E 00	4	3	0.504016E 00	4	4	0.456187E 00
4	7	0.499738E 00	4	8	0.471843E 00	4	9	0.456748E 00
4	12	0.414472E 00	4	13	0.409140E 00	4	14	0.401518E 00
4	17	0.302314E 00	4	18	0.329290E 00	4	19	0.348269E 00
4	23	0.253276E 00	4	24	0.295296E 00	4	27	0.126293E 00
4	28	0.192187E 00	4	29	0.248825E 00	4	32	0.850739E-01
4	33	0.150786E 00	4	34	0.211972E 00	4	37	0.647563E-01
4	38	0.124911E 00	4	39	0.185296E 00	4	42	0.559776E-01
4	43	0.110194E 00	4	44	0.167207E 00	4	47	0.535921E-01
4	48	0.102352E 00	4	49	0.155538E 00	4	52	0.532181E-01
4	53	0.981024E-01	4	54	0.148424E 00	4	57	0.518628E-01
4	58	0.955566E-01	4	59	0.144587E 00	4	63	0.947165E-01
4	64	0.143349E 00	4	67	0.518787E-01	4	68	0.955536E-01
4	69	0.144567E 00	4	72	0.532002E-01	4	73	0.981044E-01
4	74	0.148405E 00	4	77	0.535616E-01	4	78	0.102331E 00
4	79	0.155530E 00	4	82	0.559762E-01	4	83	0.110193E 00
4	84	0.167207E 00	4	87	0.647427E-01	4	88	0.124912E 00
4	89	0.185316E 00	4	92	0.850574E-01	4	93	0.150763E 00
4	94	0.212001E 00	4	97	0.126283E 00	4	98	0.192195E 00
4		0.248841E 00	4	103	0.253320E 00	4	104	0.295288E 00
4	107	0.302370E 00	4	108	0.329309E 00	4	109	0.348261E 00
4	112	0.414484E 00	4	113	0.409134E 00	4	114	0.401539E 00
4	117	0.499727E 00	4	118	0.471845E 00	4	119	0.456773E 00
5	2	0.387546E 00	5	3	0.390023E 00	5	4	0.422257E 00
5	7	0.368476E 00	5	8	0.378866E 00	5	9	0.406248E 00
5	12	0.316696E 00	5	13	0.344148E 00	5	14	0.380521E 00
5	17	0.248146E 00	5	18	0.297280E 00	5	19	0.346140E 00
5	23	0.252824E 00	5	24	0.311439E 00	5	27	0.153048E 00
5	28	0.219095E 00	5	29	0.281271E 00	5	32	0.139043E 00
5	33	0.198245E 00	5	34	0.257391E 00	5	37	0.134172E 00
5	38	0.184985E 00	5	39	0.239480E 00	5	42	0.129724E 00
5	43	0.175253E 00	5	44	0.225914E 00	5	47	0.122751E 00
5	48	0.166361E 00	5	49	0.215370E 00	5	52	0.112288E 00
5	53	0.157626E 00	5	54	0.207334E 00	5	57	0.100930E 00
5	58	0.150300E 00	5	59	0.202114E 00	5	63	0.147543E 00
5	64	0.200243E 00	5	67	0.100951E 00	5	68	0.150297E 00
5	69	0.202092E 00	5	72	0.112275E 00	5	73	0.157627E 00
5	74	0.207312E 00	5	77	0.122722E 00	5	78	0.166339E 00
5	79	0.215358E 00	5	82	0.129723E 00	5	83	0.175253E 00
5	84	0.225913E 00	5	87	0.134137E 00	5	88	0.184965E 00
5	89	0.239478E 00	5	92	0.139008E 00	5	93	0.198208E 00
5	94	0.257402E 00	5	97	0.153015E 00	5	98	0.219090E 00
5	99	0.281283E 00	5	103	0.252857E 00	5	104	0.311436E 00
5	107	0.248229E 00	5	108	0.297317E 00	5	109	0.346135E 00
5	112	0.316758E 00	5	113	0.344193E 00	5	114	0.380544E 00

5	117	0.368535E 00	5	118	0.378913E 00	5	119	0.406286E 00
6	2	0.986328E 00	6	3	0.746352E 00	6	4	0.541422E 00
6	7	0.979743E 00	6	8	0.729325E 00	6	9	0.530482E 00
6	12	0.797113E 00	6	13	0.626434E 00	6	14	0.473494E 00
6	17	0.528883E 00	6	18	0.462790E 00	6	19	0.383702E 00
6	23	0.286105E 00	6	24	0.279544E 00	6	27	0.600127E-01
6	28	0.132378E 00	6	29	0.180177E 00	6	32	-0.756701E-01
6	33	0.204826E-01	6	34	0.987337E-01	6	37	-0.149044E 00
6	38	-0.488413E-01	6	39	0.410351E-01	6	42	-0.172730E 00
6	43	-0.810283E-01	6	44	0.640300E-02	6	47	-0.159533E 00
6	48	-0.854881E-01	6	49	-0.976750E-02	6	52	-0.125485E 00
6	53	-0.741658E-01	6	54	-0.137591E-01	6	57	-0.916884E-01
6	58	-0.591383E-01	6	59	-0.120910E-01	6	63	-0.504553E-01
6	64	-0.963850E-02	6	67	-0.804231E-01	6	68	-0.519339E-01
6	69	-0.867190E-02	6	72	-0.105266E 00	6	73	-0.616283E-01
6	74	-0.812980E-02	6	77	-0.134934E 00	6	78	-0.712240E-01
6	79	-0.421190E-02	6	82	-0.150682E 00	6	83	-0.699703E-01
6	84	0.869560E-02	6	87	-0.137634E 00	6	88	-0.467574E-01
6	89	0.366779E-01	6	92	-0.832999E-01	6	93	0.755160E-02
6	94	0.843422E-01	6	97	0.248234E-01	6	98	0.989479E-01
6	99	0.153436E 00	6	103	0.227757E 00	6	104	0.241044E 00
6	107	0.410074E 00	6	108	0.382485E 00	6	109	0.338833E 00
6	112	0.646733E 00	6	113	0.541851E 00	6	114	0.432876E 00
6	117	0.857176E 00	6	118	0.674670E 00	6	119	0.505992E 00
7	2	0.825499E 00	7	3	0.652828E 00	7	4	0.498268E 00
7	7	0.818505E 00	7	8	0.648912E 00	7	9	0.489289E 00
7	12	0.671164E 00	7	13	0.555946E 00	7	14	0.444422E 00
7	17	0.451912E 00	7	18	0.420156E 00	7	19	0.370657E 00
7	23	0.279191E 00	7	24	0.285904E 00	7	27	0.920055E-01
7	28	0.159084E 00	7	29	0.206037E 00	7	32	-0.913630E-02
7	33	0.726482E-01	7	34	0.140759E 00	7	37	-0.636972E-01
7	38	0.185336E-01	7	39	0.939383E-01	7	42	-0.831861E-01
7	43	-0.835370E-02	7	44	0.645477E-01	7	47	-0.775512E-01
7	48	-0.155882E-01	7	49	0.488689E-01	7	52	-0.583577E-01
7	53	-0.118539E-01	7	54	0.422816E-01	7	57	-0.400111E-01
7	58	-0.543620E-02	7	59	0.402411E-01	7	63	-0.267710E-02
7	64	0.394923E-01	7	67	-0.391236E-01	7	68	-0.584590E-02
7	69	0.386569E-01	7	72	-0.575192E-01	7	73	-0.134464E-01
7	74	0.386181E-01	7	77	-0.785429E-01	7	78	-0.198747E-01
7	79	0.421761E-01	7	82	-0.888029E-01	7	83	-0.173348E-01
7	84	0.535109E-01	7	87	-0.773149E-01	7	88	0.234340E-02
7	89	0.770766E-01	7	92	-0.343307E-01	7	93	0.464283E-01
7	94	0.116552E 00	7	97	0.509498E-01	7	98	0.120061E 00
7	99	0.173462E 00	7	103	0.224479E 00	7	104	0.245601E 00
7	107	0.361485E 00	7	108	0.350549E 00	7	109	0.326382E 00
7	112	0.553500E 00	7	113	0.480628E 00	7	114	0.404660E 00
7	117	0.718370E 00	7	118	0.589914E 00	7	119	0.466634E 00
8	2	0.660105E 00	8	3	0.575496E 00	8	4	0.469824E 00
8	7	0.654819E 00	8	8	0.565833E 00	8	9	0.473417E 00
8	12	0.539738E 00	8	13	0.500868E 00	8	14	0.429484E 00
8	17	0.383066E 00	8	18	0.382241E 00	8	19	0.367642E 00
8	23	0.276518E 00	8	24	0.298903E 00	8	27	0.123179E 00
8	28	0.187651E 00	8	29	0.236613E 00	8	32	0.549691E-01
8	33	0.125255E 00	8	34	0.186105E 00	8	37	0.185766E-01
8	38	0.855870E-01	8	39	0.149308E 00	8	42	0.337030E-02
8	43	0.638115E-01	8	44	0.124739E 00	8	47	0.219060E-02
8	48	0.541308E-01	8	49	0.109515E 00	8	52	0.759070E-02

8	53	0.508831E-01	8	54	0.100545E 00	8	57	0.115766E-01
8	58	0.494029E-01	8	59	0.951501E-01	8	63	0.469405E-01
8	64	0.916013E-01	8	67	0.390390E-02	8	68	0.426724E-01
8	69	0.893422E-01	8	72	-0.753620E-02	8	73	0.375718E-01
8	74	0.890312E-01	8	77	-0.198115E-01	8	78	0.344879E-01
8	79	0.924563E-01	8	82	-0.248802E-01	8	83	0.382351E-01
8	84	0.102316E 00	8	87	-0.153426E-01	8	88	0.543026E-01
8	89	0.121649E 00	8	92	0.159538E-01	8	93	0.881793E-01
8	94	0.153224E 00	8	97	0.784113E-01	8	98	0.144326E 00
8	99	0.198441E 00	8	103	0.225026E 00	8	104	0.255894E 00
8	107	0.316171E 00	8	108	0.323515E 00	8	109	0.320840E 00
8	112	0.464601E 00	8	113	0.426317E 00	8	114	0.384881E 00
8	117	0.590342E 00	8	118	0.511708E 00	8	119	0.438666E 00
9	2	0.508786E 00	9	3	0.475589E 00	9	4	0.456733E 00
9	7	0.490110E 00	9	8	0.478104E 00	9	9	0.440826E 00
9	12	0.420390E 00	9	13	0.421912E 00	9	14	0.428931E 00
9	17	0.316421E 00	9	18	0.347624E 00	9	19	0.367572E 00
9	23	0.273853E 00	9	24	0.315326E 00	9	27	0.150492E 00
9	28	0.215042E 00	9	29	0.269421E 00	9	32	0.113109E 00
9	33	0.175267E 00	9	34	0.232651E 00	9	37	0.941350E-01
9	38	0.149460E 00	9	39	0.205193E 00	9	42	0.836914E-01
9	43	0.132954E 00	9	44	0.185247E 00	9	47	0.770653E-01
9	48	0.121613E 00	9	49	0.170715E 00	9	52	0.705304E-01
9	53	0.112552E 00	9	54	0.159916E 00	9	57	0.620794E-01
9	58	0.104486E 00	9	59	0.151895E 00	9	63	0.980724E-01
9	64	0.146315E 00	9	67	0.490679E-01	9	68	0.937721E-01
9	69	0.143333E 00	9	72	0.455242E-01	9	73	0.919164E-01
9	74	0.143303E 00	9	77	0.422965E-01	9	78	0.925283E-01
9	79	0.146972E 00	9	82	0.421616E-01	9	83	0.974867E-01
9	84	0.155578E 00	9	87	0.491313E-01	9	88	0.109730E 00
9	89	0.170818E 00	9	92	0.680379E-01	9	93	0.133155E 00
9	94	0.194646E 00	9	97	0.107277E 00	9	98	0.171742E 00
9	99	0.228432E 00	9	103	0.228920E 00	9	104	0.271616E 00
9	107	0.273404E 00	9	108	0.300394E 00	9	109	0.321189E 00
9	112	0.380634E 00	9	113	0.375805E 00	9	114	0.371409E 00
9	117	0.467545E 00	9	118	0.439374E 00	9	119	0.415581E 00
10	2	0.378183E 00	10	3	0.384004E 00	10	4	0.408022E 00
10	7	0.365257E 00	10	8	0.375878E 00	10	9	0.414716E 00
10	12	0.318777E 00	10	13	0.349314E 00	10	14	0.391360E 00
10	17	0.255665E 00	10	18	0.308267E 00	10	19	0.362752E 00
10	23	0.268423E 00	10	24	0.330331E 00	10	27	0.171477E 00
10	28	0.238170E 00	10	29	0.301374E 00	10	32	0.162198E 00
10	33	0.219798E 00	10	34	0.277815E 00	10	37	0.159799E 00
10	38	0.207390E 00	10	39	0.259274E 00	10	42	0.154934E 00
10	43	0.196617E 00	10	44	0.243992E 00	10	47	0.144745E 00
10	48	0.184773E 00	10	49	0.230622E 00	10	52	0.128759E 00
10	53	0.171502E 00	10	54	0.218810E 00	10	57	0.110410E 00
10	58	0.158592E 00	10	59	0.209158E 00	10	63	0.149870E 00
10	64	0.202559E 00	10	67	0.961417E-01	10	68	0.146879E 00
10	69	0.199746E 00	10	72	0.101610E 00	10	73	0.149174E 00
10	74	0.200683E 00	10	77	0.107751E 00	10	78	0.153888E 00
10	79	0.205045E 00	10	82	0.112173E 00	10	83	0.160005E 00
10	84	0.212611E 00	10	87	0.115809E 00	10	88	0.168131E 00
10	89	0.223875E 00	10	92	0.121478E 00	10	93	0.180755E 00
10	94	0.240053E 00	10	97	0.137036E 00	10	98	0.201593E 00
10	99	0.262546E 00	10	103	0.235305E 00	10	104	0.291593E 00
10	107	0.233218E 00	10	108	0.279874E 00	10	109	0.325633E 00

10	112	0.301842E 00	10	113	0.327921E 00	10	114	0.360454E 00
10	117	0.355522E 00	10	118	0.366005E 00	10	119	0.390472E 00
11	2	0.739367E 00	11	3	0.575890E 00	11	4	0.427242E 00
11	7	0.775827E 00	11	8	0.588038E 00	11	9	0.429858E 00
11	12	0.699018E 00	11	13	0.530384E 00	11	14	0.396393E 00
11	17	0.502241E 00	11	18	0.415542E 00	11	19	0.332709E 00
11	23	0.274333E 00	11	24	0.252398E 00	11	27	0.929422E-01
11	28	0.142831E 00	11	29	0.171294E 00	11	32	-0.283303E-01
11	33	0.446396E-01	11	34	0.101898E 00	11	37	-0.978942E-01
11	38	-0.187358E-01	11	39	0.509695E-01	11	42	-0.125499E 00
11	43	-0.510458E-01	11	44	0.189527E-01	11	47	-0.121101E 00
11	48	-0.594836E-01	11	49	0.258040E-02	11	52	-0.973018E-01
11	53	-0.534124E-01	11	54	-0.294840E-02	11	57	-0.712010E-01
11	58	-0.425627E-01	11	59	-0.286490E-02	11	63	-0.352933E-01
11	64	-0.126120E-02	11	67	-0.585787E-01	11	68	-0.351948E-01
11	69	-0.295600E-03	11	72	-0.753705E-01	11	73	-0.414098E-01
11	74	0.441000E-03	11	77	-0.965307E-01	11	78	-0.480533E-01
11	79	0.350560E-02	11	82	-0.108348E 00	11	83	-0.472441E-01
11	84	0.130099E-01	11	87	-0.999939E-01	11	88	-0.309475E-01
11	89	0.332851E-01	11	92	-0.620156E-01	11	93	0.779160E-02
11	94	0.679227E-01	11	97	0.151326E-01	11	98	0.736362E-01
11	99	0.118454E 00	11	103	0.167118E 00	11	104	0.183209E 00
11	107	0.292962E 00	11	108	0.280836E 00	11	109	0.256780E 00
11	112	0.466888E 00	11	113	0.400713E 00	11	114	0.329916E 00
11	117	0.626845E 00	11	118	0.506352E 00	11	119	0.390885E 00
12	2	0.639496E 00	12	3	0.523255E 00	12	4	0.413273E 00
12	7	0.670697E 00	12	8	0.537800E 00	12	9	0.418718E 00
12	12	0.606006E 00	12	13	0.500464E 00	12	14	0.391804E 00
12	17	0.444036E 00	12	18	0.397897E 00	12	19	0.341827E 00
12	23	0.281131E 00	12	24	0.276249E 00	12	27	0.127505E 00
12	28	0.178422E 00	12	29	0.210360E 00	12	32	0.403331E-01
12	33	0.103606E 00	12	34	0.154389E 00	12	37	-0.951250E-02
12	38	0.546091E-01	12	39	0.112637E 00	12	42	-0.320204E-01
12	43	0.272245E-01	12	44	0.846223E-01	12	47	-0.348334E-01
12	48	0.154838E-01	12	49	0.675827E-01	12	52	-0.266402E-01
12	53	0.127930E-01	12	54	0.580617E-01	12	57	-0.182497E-01
12	58	0.129663E-01	12	59	0.526630E-01	12	63	0.113614E-01
12	64	0.489525E-01	12	67	-0.246993E-01	12	68	0.626440E-02
12	69	0.458769E-01	12	72	-0.403345E-01	12	73	-0.133740E-02
12	74	0.440359E-01	12	77	-0.573072E-01	12	78	-0.746930E-02
12	79	0.454504E-01	12	82	-0.658931E-01	12	83	-0.642040E-02
12	84	0.532003E-01	12	87	-0.579470E-01	12	88	0.783590E-02
12	89	0.705729E-01	12	92	-0.260940E-01	12	93	0.408065E-01
12	94	0.100381E 00	12	97	0.379780E-01	12	98	0.964780E-01
12	99	0.143881E 00	12	103	0.175935E 00	12	104	0.199660E 00
12	107	0.273093E 00	12	108	0.272872E 00	12	109	0.263149E 00
12	112	0.420392E 00	12	113	0.374967E 00	12	114	0.326451E 00
12	117	0.553074E 00	12	118	0.464017E 00	12	119	0.379851E 00
13	2	0.546655E 00	13	3	0.474155E 00	13	4	0.408294E 00
13	7	0.557449E 00	13	8	0.500755E 00	13	9	0.419819E 00
13	12	0.506543E 00	13	13	0.464738E 00	13	14	0.409819E 00
13	17	0.377656E 00	13	18	0.391965E 00	13	19	0.362229E 00
13	23	0.289478E 00	13	24	0.306976E 00	13	27	0.159164E 00
13	28	0.214343E 00	13	29	0.252995E 00	13	32	0.103729E 00
13	33	0.160714E 00	13	34	0.208628E 00	13	37	0.724431E-01
13	38	0.125046E 00	13	39	0.174920E 00	13	42	0.551062E-01
13	43	0.102395E 00	13	44	0.150466E 00	13	47	0.461687E-01

13	48	0.879137E-01	13	49	0.132848E 00	13	52	0.405347E-01
13	53	0.775627E-01	13	54	0.119844E 00	13	57	0.332800E-01
13	58	0.684596E-01	13	59	0.109736E 00	13	63	0.594654E-01
13	64	0.101593E 00	13	67	0.117437E-01	13	68	0.505352E-01
13	69	0.953273E-01	13	72	-0.129160E-02	13	73	0.426117E-01
13	74	0.916124E-01	13	77	-0.132883E-01	13	78	0.376274E-01
13	79	0.918600E-01	13	82	-0.185790E-01	13	83	0.390716E-01
13	84	0.980770E-01	13	87	-0.115571E-01	13	88	0.510667E-01
13	89	0.112577E 00	13	92	0.132301E-01	13	93	0.777889E-01
13	94	0.137459E 00	13	97	0.631832E-01	13	98	0.122736E 00
13	99	0.173816E 00	13	103	0.187742E 00	13	104	0.220624E 00
13	107	0.254248E 00	13	108	0.267812E 00	13	109	0.274286E 00
13	112	0.375267E 00	13	113	0.352425E 00	13	114	0.328405E 00
13	117	0.480753E 00	13	118	0.426193E 00	13	119	0.375288E 00
14	2	0.448495E 00	14	3	0.422339E 00	14	4	0.401481E 00
14	7	0.445854E 00	14	8	0.431462E 00	14	9	0.428909E 00
14	12	0.392819E 00	14	13	0.414575E 00	14	14	0.403470E 00
14	17	0.312881E 00	14	18	0.352905E 00	14	19	0.389356E 00
14	23	0.291924E 00	14	24	0.333236E 00	14	27	0.181193E 00
14	28	0.241865E 00	14	29	0.291952E 00	14	32	0.154877E 00
14	33	0.208983E 00	14	34	0.258562E 00	14	37	0.140945E 00
14	38	0.186245E 00	14	39	0.232612E 00	14	42	0.129359E 00
14	43	0.168843E 00	14	44	0.211880E 00	14	47	0.116511E 00
14	48	0.153158E 00	14	49	0.194501E 00	14	52	0.100344E 00
14	53	0.137425E 00	14	54	0.179338E 00	14	57	0.812210E-01
14	58	0.121740E 00	14	59	0.166174E 00	14	63	0.108143E 00
14	64	0.155360E 00	14	67	0.518875E-01	14	68	0.979289E-01
14	69	0.147558E 00	14	72	0.441766E-01	14	73	0.917068E-01
14	74	0.143323E 00	14	77	0.387905E-01	14	78	0.891369E-01
14	79	0.143319E 00	14	82	0.372424E-01	14	83	0.914344E-01
14	84	0.148459E 00	14	87	0.425446E-01	14	88	0.100745E 00
14	89	0.160002E 00	14	92	0.584689E-01	14	93	0.120107E 00
14	94	0.179458E 00	14	97	0.919077E-01	14	98	0.152756E 00
14	99	0.207894E 00	14	103	0.201548E 00	14	104	0.244832E 00
14	107	0.234074E 00	14	108	0.263032E 00	14	109	0.287782E 00
14	112	0.327024E 00	14	113	0.328765E 00	14	114	0.331851E 00
14	117	0.405207E 00	14	118	0.385277E 00	14	119	0.371399E 00
15	2	0.353089E 00	15	3	0.362543E 00	15	4	0.386802E 00
15	7	0.345507E 00	15	8	0.362466E 00	15	9	0.395779E 00
15	12	0.308348E 00	15	13	0.341211E 00	15	14	0.396519E 00
15	17	0.254920E 00	15	18	0.311356E 00	15	19	0.372137E 00
15	23	0.280857E 00	15	24	0.347451E 00	15	27	0.191703E 00
15	28	0.258215E 00	15	29	0.322483E 00	15	32	0.190645E 00
15	33	0.245164E 00	15	34	0.301205E 00	15	37	0.192685E 00
15	38	0.235319E 00	15	39	0.283274E 00	15	42	0.187994E 00
15	43	0.224206E 00	15	44	0.266925E 00	15	47	0.174030E 00
15	48	0.209293E 00	15	49	0.250888E 00	15	52	0.151262E 00
15	53	0.190900E 00	15	54	0.235157E 00	15	57	0.124612E 00
15	58	0.171722E 00	15	59	0.220821E 00	15	63	0.156604E 00
15	64	0.209283E 00	15	67	0.954047E-01	15	68	0.147835E 00
15	69	0.201724E 00	15	72	0.957870E-01	15	73	0.145404E 00
15	74	0.198393E 00	15	77	0.985628E-01	15	78	0.146500E 00
15	79	0.199080E 00	15	82	0.100962E 00	15	83	0.149950E 00
15	84	0.213496E 00	15	87	0.103635E 00	15	88	0.156109E 00
15	89	0.212003E 00	15	92	0.108880E 00	15	93	0.167008E 00
15	94	0.225560E 00	15	97	0.123546E 00	15	98	0.185874E 00
15	99	0.245342E 00	15	103	0.216832E 00	15	104	0.271534E 00

15 107	0.212793E 00	15 108	0.258178E 00	15 109	0.302781E 00
15 112	0.276835E 00	15 113	0.303505E 00	15 114	0.335491E 00
15 117	0.328443E 00	15 118	0.341268E 00	15 119	0.365038E 00
16 2	0.419889E 00	16 3	0.339294E 00	16 4	0.263284E 00
16 7	0.454719E 00	16 8	0.360403E 00	16 9	0.274125E 00
16 12	0.443266E 00	16 13	0.348691E 00	16 14	0.265222E 00
16 17	0.378412E 00	16 18	0.300813E 00	16 19	0.237894E 00
16 23	0.229011E 00	16 24	0.197312E 00	16 27	0.141552E 00
16 28	0.152609E 00	16 29	0.151760E 00	16 32	0.605809E-01
16 33	0.893043E-01	16 34	0.109146E 00	16 37	0.706070E-02
16 38	0.438423E-01	16 39	0.746478E-01	16 42	-0.223452E-01
16 43	0.154735E-01	16 44	0.500438E-01	16 47	-0.332876E-01
16 48	0.494500E-03	16 49	0.338149E-01	16 52	-0.317976E-01
16 53	-0.542140E-02	16 54	0.240781E-01	16 57	-0.270588E-01
16 58	-0.729130E-02	16 59	0.182786E-01	16 63	-0.958610E-02
16 64	0.143473E-01	16 67	-0.333954E-01	16 68	-0.142337E-01
16 69	0.111644E-01	16 72	-0.462416E-01	16 73	-0.208290E-01
16 74	0.895220E-02	16 77	-0.595584E-01	16 78	-0.262202E-01
16 79	0.904250E-02	16 82	-0.663341E-01	16 83	-0.263390E-01
16 84	0.135802E-01	16 87	-0.609386E-01	16 88	-0.170252E-01
16 89	0.247872E-01	16 92	-0.386449E-01	16 93	0.521790E-02
16 94	0.444809E-01	16 97	0.537110E-02	16 98	0.427131E-01
16 99	0.734019E-01	16 103	0.956032E-01	16 104	0.110671E 00
16 107	0.160718E 00	16 108	0.160120E 00	16 109	0.153528E 00
16 112	0.258267E 00	16 113	0.229154E 00	16 114	0.197298E 00
16 117	0.350364E 00	16 118	0.292497E 00	16 119	0.236064E 00
17 2	0.424940E 00	17 3	0.360600E 00	17 4	0.301238E 00
17 7	0.451279E 00	17 8	0.381989E 00	17 9	0.314971E 00
17 12	0.443481E 00	17 13	0.375560E 00	17 14	0.310961E 00
17 17	0.378260E 00	17 18	0.342651E 00	17 19	0.288456E 00
17 23	0.275441E 00	17 24	0.255725E 00	17 27	0.182262E 00
17 28	0.208400E 00	17 29	0.217070E 00	17 32	0.126588E 00
17 33	0.158366E 00	17 34	0.180153E 00	17 37	0.907800E-01
17 38	0.122194E 00	17 39	0.149541E 00	17 42	0.665249E-01
17 43	0.964048E-01	17 44	0.125420E 00	17 47	0.499092E-01
17 48	0.775117E-01	17 49	0.106485E 00	17 52	0.371705E-01
17 53	0.624844E-01	17 54	0.912510E-01	17 57	0.241293E-01
17 58	0.490064E-01	17 59	0.784781E-01	17 63	0.358841E-01
17 64	0.675060E-01	17 67	-0.744330E-02	17 68	0.231368E-01
17 69	0.583545E-01	17 72	-0.244548E-01	17 73	0.118082E-01
17 74	0.517471E-01	17 77	-0.387109E-01	17 78	0.407530E-02
17 79	0.489987E-01	17 82	-0.451940E-01	17 83	0.301250E-02
17 84	0.518504E-01	17 87	-0.395089E-01	17 88	0.118414E-01
17 89	0.620821E-01	17 92	-0.177580E-01	17 93	0.334894E-01
17 94	0.811790E-01	17 97	0.246422E-01	17 98	0.700746E-01
17 99	0.109719E 00	17 103	0.122058E 00	17 104	0.146756E 00
17 107	0.177007E 00	17 108	0.185752E 00	17 109	0.189530E 00
17 112	0.272767E 00	17 113	0.253740E 00	17 114	0.233364E 00
17 117	0.360828E 00	17 118	0.315429E 00	17 119	0.272518E 00
18 2	0.402814E 00	18 3	0.363885E 00	18 4	0.328774E 00
18 7	0.420658E 00	18 8	0.382201E 00	18 9	0.346807E 00
18 12	0.399792E 00	18 13	0.391973E 00	18 14	0.350838E 00
18 17	0.348813E 00	18 18	0.358293E 00	18 19	0.343932E 00
18 23	0.311952E 00	18 24	0.309448E 00	18 27	0.209042E 00
18 28	0.248844E 00	18 29	0.274197E 00	18 32	0.178519E 00
18 33	0.214235E 00	18 34	0.241328E 00	18 37	0.158886E 00
18 38	0.187402E 00	18 39	0.214593E 00	18 42	0.140217E 00

18	43	0.165188E 00	18	44	0.191779E 00	18	47	0.119791E 00
18	48	0.144020E 00	18	49	0.171354E 00	18	52	0.962694E-01
18	53	0.122511E 00	18	54	0.152432E 00	18	57	0.699790E-01
18	58	0.100802E 00	18	59	0.134951E 00	18	63	0.806015E-01
18	64	0.119427E 00	18	67	0.231803E-01	18	68	0.634332E-01
18	69	0.106736E 00	18	72	0.634350E-02	18	73	0.505331E-01
18	74	0.978079E-01	18	77	-0.572730E-02	18	78	0.426906E-01
18	79	0.936736E-01	18	82	-0.105842E-01	18	83	0.416340E-01
18	84	0.954760E-01	18	87	-0.525590E-02	18	88	0.494872E-01
18	89	0.104437E 00	18	92	0.132309E-01	18	93	0.685639E-01
18	94	0.121699E 00	18	97	0.494339E-01	18	98	0.100922E 00
18	99	0.147797E 00	18	103	0.147753E 00	18	104	0.181936E 00
18	107	0.186110E 00	18	108	0.205719E 00	18	109	0.221681E 00
18	112	0.273089E 00	18	113	0.267808E 00	18	114	0.262738E 00
18	117	0.350653E 00	18	118	0.323432E 00	18	119	0.300025E 00
19	2	0.365199E 00	19	3	0.353536E 00	19	4	0.348198E 00
19	7	0.371541E 00	19	8	0.368313E 00	19	9	0.367522E 00
19	12	0.343390E 00	19	13	0.364268E 00	19	14	0.389330E 00
19	17	0.289769E 00	19	18	0.348667E 00	19	19	0.365988E 00
19	23	0.307229E 00	19	24	0.361113E 00	19	27	0.218444E 00
19	28	0.274983E 00	19	29	0.319079E 00	19	32	0.210958E 00
19	33	0.253434E 00	19	34	0.291909E 00	19	37	0.206275E 00
19	38	0.236777E 00	19	39	0.269342E 00	19	42	0.194455E 00
19	43	0.219388E 00	19	44	0.248712E 00	19	47	0.173490E 00
19	48	0.198419E 00	19	49	0.228288E 00	19	52	0.143935E 00
19	53	0.173836E 00	19	54	0.207778E 00	19	57	0.109875E 00
19	58	0.147870E 00	19	59	0.188088E 00	19	63	0.124696E 00
19	64	0.170631E 00	19	67	0.585962E-01	19	68	0.106888E 00
19	69	0.156840E 00	19	72	0.460876E-01	19	73	0.954615E-01
19	74	0.147573E 00	19	77	0.388675E-01	19	78	0.894752E-01
19	79	0.143359E 00	19	82	0.365063E-01	19	83	0.891018E-01
19	84	0.144606E 00	19	87	0.404857E-01	19	88	0.953192E-01
19	89	0.151948E 00	19	92	0.529990E-01	19	93	0.109938E 00
19	94	0.166248E 00	19	97	0.789745E-01	19	98	0.135199E 00
19	99	0.188154E 00	19	103	0.173355E 00	19	104	0.217251E 00
19	107	0.190070E 00	19	108	0.221908E 00	19	109	0.251676E 00
19	112	0.263551E 00	19	113	0.274536E 00	19	114	0.287755E 00
19	117	0.326735E 00	19	118	0.321070E 00	19	119	0.321152E 00
20	2	0.315701E 00	20	3	0.330749E 00	20	4	0.357188E 00
20	7	0.313283E 00	20	8	0.336102E 00	20	9	0.371651E 00
20	12	0.285813E 00	20	13	0.325913E 00	20	14	0.376496E 00
20	17	0.246598E 00	20	18	0.304742E 00	20	19	0.378259E 00
20	23	0.288732E 00	20	24	0.359692E 00	20	27	0.212367E 00
20	28	0.277821E 00	20	29	0.343836E 00	20	32	0.223010E 00
20	33	0.273337E 00	20	34	0.327124E 00	20	37	0.231695E 00
20	38	0.268006E 00	20	39	0.311203E 00	20	42	0.228006E 00
20	43	0.257407E 00	20	44	0.294458E 00	20	47	0.210024E 00
20	48	0.239504E 00	20	49	0.275976E 00	20	52	0.179452E 00
20	53	0.215540E 00	20	54	0.256226E 00	20	57	0.143292E 00
20	58	0.189460E 00	20	59	0.236961E 00	20	63	0.167475E 00
20	64	0.220244E 00	20	67	0.982549E-01	20	68	0.152774E 00
20	69	0.207792E 00	20	72	0.940483E-01	20	73	0.145771E 00
20	74	0.200136E 00	20	77	0.941342E-01	20	78	0.143492E 00
20	79	0.197117E 00	20	82	0.949826E-01	20	83	0.144412E 00
20	84	0.198292E 00	20	87	0.965875E-01	20	88	0.143345E 00
20	89	0.203709E 00	20	92	0.100549E 00	20	93	0.156745E 00
20	94	0.214027E 00	20	97	0.112588E 00	20	98	0.172284E 00

20	99	0.230165E 00	20	103	0.198612E 00	20	104	0.252281E 00
20	107	0.189348E 00	20	108	0.234426E 00	20	109	0.279284E 00
20	112	0.245398E 00	20	113	0.274417E 00	20	114	0.308220E 00
20	117	0.291571E 00	20	118	0.308899E 00	20	119	0.335369E 00
21	2	0.171331E 00	21	3	0.153822E 00	21	4	0.136354E 00
21	7	0.203057E 00	21	8	0.178399E 00	21	9	0.153775E 00
21	12	0.227411E 00	21	13	0.197157E 00	21	14	0.167102E 00
21	17	0.241925E 00	21	18	0.208954E 00	21	19	0.175446E 00
21	23	0.212602E 00	21	24	0.178374E 00	21	27	0.241911E 00
21	28	0.208952E 00	21	29	0.175458E 00	21	32	0.227413E 00
21	33	0.197154E 00	21	34	0.167109E 00	21	37	0.203076E 00
21	38	0.178407E 00	21	39	0.153771E 00	21	42	0.171335E 00
21	43	0.153826E 00	21	44	0.136357E 00	21	47	0.134245E 00
21	48	0.125129E 00	21	49	0.116026E 00	21	52	0.943882E-01
21	53	0.942911E-01	21	54	0.941834E-01	21	57	0.544984E-01
21	58	0.634114E-01	21	59	0.723236E-01	21	63	0.346095E-01
21	64	0.519382E-01	21	67	-0.146377E-01	21	68	0.989120E-02
21	69	0.344154E-01	21	72	-0.391666E-01	21	73	-0.909710E-02
21	74	0.209654E-01	21	77	-0.545722E-01	21	78	-0.210277E-01
21	79	0.125077E-01	21	82	-0.598475E-01	21	83	-0.251024E-01
21	84	0.962810E-02	21	87	-0.545711E-01	21	88	-0.210249E-01
21	89	0.125121E-01	21	92	-0.391660E-01	21	93	-0.910760E-02
21	94	0.209751E-01	21	97	-0.146377E-01	21	98	0.989300E-02
21	99	0.344190E-01	21	103	0.346230E-01	21	104	0.519307E-01
21	107	0.545119E-01	21	108	0.634134E-01	21	109	0.723141E-01
21	112	0.943842E-01	21	113	0.942820E-01	21	114	0.941850E-01
21	117	0.134224E 00	21	118	0.125122E 00	21	119	0.116033E 00
22	2	0.217201E 00	22	3	0.203858E 00	22	4	0.191946E 00
22	7	0.241914E 00	22	8	0.225927E 00	22	9	0.209854E 00
22	12	0.253926E 00	22	13	0.241257E 00	22	14	0.223211E 00
22	17	0.260758E 00	22	18	0.251251E 00	22	19	0.231586E 00
22	23	0.256270E 00	22	24	0.234228E 00	22	27	0.260800E 00
22	28	0.251275E 00	22	29	0.231606E 00	22	32	0.253999E 00
22	33	0.241298E 00	22	34	0.223236E 00	22	37	0.242000E 00
22	38	0.225981E 00	22	39	0.209876E 00	22	42	0.217205E 00
22	43	0.203861E 00	22	44	0.191948E 00	22	47	0.180962E 00
22	48	0.174729E 00	22	49	0.170141E 00	22	52	0.136345E 00
22	53	0.140578E 00	22	54	0.145706E 00	22	57	0.886756E-01
22	58	0.104681E 00	22	59	0.120581E 00	22	63	0.710917E-01
22	64	0.969018E-01	22	67	0.880150E-02	22	68	0.429326E-01
22	69	0.766526E-01	22	72	-0.167890E-01	22	73	0.221851E-01
22	74	0.613017E-01	22	77	-0.322390E-01	22	78	0.948260E-02
22	79	0.517901E-01	22	82	-0.374654E-01	22	83	0.521370E-02
22	84	0.485882E-01	22	87	-0.322344E-01	22	88	0.949260E-02
22	89	0.518052E-01	22	92	-0.167860E-01	22	93	0.221792E-01
22	94	0.613251E-01	22	97	0.880350E-02	22	98	0.429443E-01
22	99	0.766715E-01	22	103	0.711218E-01	22	104	0.969093E-01
22	107	0.887150E-01	22	108	0.104705E 00	22	109	0.120588E 00
22	112	0.136370E 00	22	113	0.140596E 00	22	114	0.145730E 00
22	117	0.180977E 00	22	118	0.174753E 00	22	119	0.170175E 00
23	2	0.259899E 00	23	3	0.254742E 00	23	4	0.252587E 00
23	7	0.279037E 00	23	8	0.276074E 00	23	9	0.272988E 00
23	12	0.281187E 00	23	13	0.289086E 00	23	14	0.290690E 00
23	17	0.277424E 00	23	18	0.311330E 00	23	19	0.304690E 00
23	23	0.314937E 00	23	24	0.315847E 00	23	27	0.277507E 00
23	28	0.311375E 00	23	29	0.304720E 00	23	32	0.281290E 00
23	33	0.289160E 00	23	34	0.290728E 00	23	37	0.279157E 00

23	38	0.276154E 00	23	39	0.273026E 00	23	42	0.259902E 00
23	43	0.254744E 00	23	44	0.252589E 00	23	47	0.224232E 00
23	48	0.224625E 00	23	49	0.228299E 00	23	52	0.175810E 00
23	53	0.187467E 00	23	54	0.201029E 00	23	57	0.122111E 00
23	58	0.147555E 00	23	59	0.172941E 00	23	63	0.110601E 00
23	64	0.146616E 00	23	67	0.360496E-01	23	68	0.805501E-01
23	69	0.124427E 00	23	72	0.114670E-01	23	73	0.594163E-01
23	74	0.107902E 00	23	77	-0.260120E-02	23	78	0.468795E-01
23	79	0.978431E-01	23	82	-0.726960E-02	23	83	0.427588E-01
23	84	0.945035E-01	23	87	-0.257990E-02	23	88	0.469046E-01
23	89	0.978720E-01	23	92	0.114825E-01	23	93	0.594209E-01
23	94	0.107941E 00	23	97	0.360575E-01	23	98	0.805731E-01
23	99	0.124461E 00	23	103	0.110644E 00	23	104	0.146635E 00
23	107	0.122167E 00	23	108	0.147589E 00	23	109	0.172956E 00
23	112	0.175845E 00	23	113	0.187496E 00	23	114	0.201062E 00
23	117	0.224254E 00	23	118	0.224657E 00	23	119	0.228343E 00
24	2	0.275943E 00	24	3	0.282916E 00	24	4	0.295275E 00
24	7	0.286427E 00	24	8	0.299308E 00	24	9	0.315346E 00
24	12	0.277355E 00	24	13	0.307813E 00	24	14	0.333311E 00
24	17	0.257599E 00	24	18	0.311657E 00	24	19	0.361238E 00
24	23	0.321303E 00	24	24	0.350337E 00	24	27	0.257640E 00
24	28	0.311662E 00	24	29	0.361229E 00	24	32	0.277373E 00
24	33	0.307828E 00	24	34	0.333297E 00	24	37	0.286443E 00
24	38	0.299312E 00	24	39	0.315332E 00	24	42	0.275945E 00
24	43	0.282918E 00	24	44	0.295276E 00	24	47	0.245831E 00
24	48	0.256043E 00	24	49	0.271583E 00	24	52	0.199908E 00
24	53	0.220799E 00	24	54	0.244814E 00	24	57	0.147098E 00
24	58	0.182113E 00	24	59	0.217273E 00	24	63	0.146960E 00
24	64	0.191741E 00	24	67	0.678785E-01	24	68	0.119640E 00
24	69	0.170690E 00	24	72	0.492323E-01	24	73	0.101786E 00
24	74	0.155425E 00	24	77	0.397248E-01	24	78	0.917650E-01
24	79	0.146380E 00	24	82	0.366647E-01	24	83	0.885597E-01
24	84	0.143395E 00	24	87	0.397194E-01	24	88	0.917611E-01
24	89	0.146377E 00	24	92	0.492209E-01	24	93	0.101759E 00
24	94	0.155432E 00	24	97	0.678555E-01	24	98	0.119631E 00
24	99	0.170691E 00	24	103	0.146967E 00	24	104	0.191722E 00
24	107	0.147123E 00	24	108	0.182109E 00	24	109	0.217242E 00
24	112	0.199898E 00	24	113	0.220785E 00	24	114	0.244797E 00
24	117	0.245800E 00	24	118	0.256023E 00	24	119	0.271577E 00
25	2	0.272071E 00	25	3	0.294056E 00	25	4	0.325260E 00
25	7	0.273463E 00	25	8	0.302908E 00	25	9	0.341497E 00
25	12	0.256066E 00	25	13	0.301503E 00	25	14	0.353809E 00
25	17	0.231345E 00	25	18	0.294577E 00	25	19	0.361575E 00
25	23	0.289838E 00	25	24	0.370586E 00	25	27	0.231416E 00
25	28	0.294606E 00	25	29	0.361578E 00	25	32	0.256132E 00
25	33	0.301560E 00	25	34	0.353827E 00	25	37	0.273533E 00
25	38	0.302960E 00	25	39	0.341526E 00	25	42	0.272073E 00
25	43	0.294057E 00	25	44	0.325260E 00	25	47	0.250422E 00
25	48	0.273632E 00	25	49	0.304725E 00	25	52	0.211690E 00
25	53	0.244064E 00	25	54	0.281049E 00	25	57	0.165379E 00
25	58	0.210815E 00	25	59	0.256794E 00	25	63	0.181738E 00
25	64	0.234803E 00	25	67	0.104081E 00	25	68	0.161058E 00
25	69	0.217399E 00	25	72	0.956659E-01	25	73	0.149622E 00
25	74	0.205410E 00	25	77	0.935161E-01	25	78	0.144146E 00
25	79	0.198684E 00	25	82	0.930732E-01	25	83	0.142606E 00
25	84	0.196556E 00	25	87	0.935259E-01	25	88	0.144160E 00
25	89	0.198702E 00	25	92	0.956681E-01	25	93	0.149615E 00

25	94	0.205441E 00	25	97	0.104067E 00	25	98	0.161070E 00
25	99	0.217429E 00	25	103	0.181768E 00	25	104	0.234814E 00
25	107	0.165437E 00	25	108	0.210843E 00	25	109	0.256795E 00
25	112	0.211719E 00	25	113	0.244094E 00	25	114	0.281066E 00
25	117	0.250437E 00	25	118	0.273653E 00	25	119	0.304757E 00
26	2	-0.223499E-01	26	3	0.154700E-01	26	4	0.500414E-01
26	7	0.738500E-02	26	8	0.441374E-01	26	9	0.749212E-01
26	12	0.608566E-01	26	13	0.895500E-01	26	14	0.109394E 00
26	17	0.141772E 00	26	18	0.152819E 00	26	19	0.151946E 00
26	23	0.229167E 00	26	24	0.197442E 00	26	27	0.378327E 00
26	28	0.300837E 00	26	29	0.237993E 00	26	32	0.443063E 00
26	33	0.348599E 00	26	34	0.265284E 00	26	37	0.454504E 00
26	38	0.360305E 00	26	39	0.274132E 00	26	42	0.419894E 00
26	43	0.339298E 00	26	44	0.263286E 00	26	47	0.350123E 00
26	48	0.292250E 00	26	49	0.235809E 00	26	52	0.258040E 00
26	53	0.228955E 00	26	54	0.197063E 00	26	57	0.160527E 00
26	58	0.159930E 00	26	59	0.153340E 00	26	63	0.954252E-01
26	64	0.110513E 00	26	67	0.528580E-02	26	68	0.425909E-01
26	69	0.732490E-01	26	72	-0.386983E-01	26	73	0.513640E-02
26	74	0.443315E-01	26	77	-0.609852E-01	26	78	-0.171133E-01
26	79	0.246545E-01	26	82	-0.663334E-01	26	83	-0.263384E-01
26	84	0.135805E-01	26	87	-0.595526E-01	26	88	-0.262136E-01
26	89	0.905100E-02	26	92	-0.462406E-01	26	93	-0.208481E-01
26	94	0.895140E-02	26	97	-0.334295E-01	26	98	-0.142678E-01
26	99	0.111426E-01	26	103	-0.965400E-02	26	104	0.142910E-01
26	107	-0.271870E-01	26	108	-0.740620E-02	26	109	0.181854E-01
26	112	-0.320189E-01	26	113	-0.558140E-02	26	114	0.239599E-01
26	117	-0.335858E-01	26	118	0.279200E-03	26	119	0.336859E-01
27	2	0.665210E-01	27	3	0.964018E-01	27	4	0.125418E 00
27	7	0.907240E-01	27	8	0.122181E 00	27	9	0.149570E 00
27	12	0.126543E 00	27	13	0.158348E 00	27	14	0.180189E 00
27	17	0.182262E 00	27	18	0.208423E 00	27	19	0.217100E 00
27	23	0.275521E 00	27	24	0.255762E 00	27	27	0.378330E 00
27	28	0.342732E 00	27	29	0.288528E 00	27	32	0.443568E 00
27	33	0.375621E 00	27	34	0.311050E 00	27	37	0.451387E 00
27	38	0.382078E 00	27	39	0.315043E 00	27	42	0.424943E 00
27	43	0.360603E 00	27	44	0.301240E 00	27	47	0.360878E 00
27	48	0.315444E 00	27	49	0.272499E 00	27	52	0.272777E 00
27	53	0.253763E 00	27	54	0.233346E 00	27	57	0.176979E 00
27	58	0.185741E 00	27	59	0.189531E 00	27	63	0.122047E 00
27	64	0.146755E 00	27	67	0.246275E-01	27	68	0.700548E-01
27	69	0.109696E 00	27	72	-0.177704E-01	27	73	0.334888E-01
27	74	0.811409E-01	27	77	-0.395266E-01	27	78	0.118177E-01
27	79	0.620493E-01	27	82	-0.451934E-01	27	83	0.301290E-02
27	84	0.518505E-01	27	87	-0.386755E-01	27	88	0.410110E-02
27	89	0.490126E-01	27	92	-0.244278E-01	27	93	0.118137E-01
27	94	0.517688E-01	27	97	-0.743640E-02	27	98	0.231507E-01
27	99	0.583729E-01	27	103	0.359030E-01	27	104	0.675105E-01
27	107	0.241612E-01	27	108	0.490215E-01	27	109	0.784737E-01
27	112	0.371847E-01	27	113	0.625031E-01	27	114	0.912540E-01
27	117	0.499200E-01	27	118	0.775227E-01	27	119	0.106499E 00
28	2	0.140214E 00	28	3	0.165186E 00	28	4	0.191778E 00
28	7	0.158833E 00	28	8	0.187378E 00	28	9	0.214600E 00
28	12	0.178473E 00	28	13	0.214203E 00	28	14	0.241339E 00
28	17	0.209018E 00	28	18	0.248843E 00	28	19	0.274200E 00
28	23	0.311997E 00	28	24	0.309451E 00	28	27	0.348897E 00
28	28	0.358320E 00	28	29	0.343961E 00	28	32	0.399847E 00

28	33	0.392009E 00	28	34	0.350878E 00	28	37	0.420724E 00
28	38	0.382249E 00	28	39	0.346834E 00	28	42	0.402816E 00
28	43	0.363887E 00	28	44	0.328776E 00	28	47	0.350666E 00
28	48	0.323427E 00	28	49	0.300001E 00	28	52	0.273075E 00
28	53	0.267812E 00	28	54	0.262722E 00	28	57	0.186066E 00
28	58	0.205702E 00	28	59	0.221687E 00	28	63	0.147718E 00
28	64	0.181941E 00	28	67	0.494348E-01	28	68	0.100913E 00
28	69	0.147781E 00	28	72	0.132339E-01	28	73	0.685785E-01
28	74	0.121674E 00	28	77	-0.525660E-02	28	78	0.494797E-01
28	79	0.104421E 00	28	82	-0.105837E-01	28	83	0.416343E-01
28	84	0.954762E-01	28	87	-0.570270E-02	28	88	0.427103E-01
28	89	0.936868E-01	28	92	0.635950E-02	28	93	0.505297E-01
28	94	0.978290E-01	28	97	0.231758E-01	28	98	0.634401E-01
28	99	0.106752E 00	28	103	0.806147E-01	28	104	0.119425E 00
28	107	0.700026E-01	28	108	0.100806E 00	28	109	0.134936E 00
28	112	0.962633E-01	28	113	0.122512E 00	28	114	0.152425E 00
28	117	0.119770E 00	28	118	0.144010E 00	28	119	0.171357E 00
29	2	0.194453E 00	29	3	0.219386E 00	29	4	0.248711E 00
29	7	0.206238E 00	29	8	0.236755E 00	29	9	0.269340E 00
29	12	0.210926E 00	29	13	0.253402E 00	29	14	0.291912E 00
29	17	0.218413E 00	29	18	0.274979E 00	29	19	0.319078E 00
29	23	0.307259E 00	29	24	0.361104E 00	29	27	0.289843E 00
29	28	0.348697E 00	29	29	0.365982E 00	29	32	0.343436E 00
29	33	0.364297E 00	29	34	0.389327E 00	29	37	0.371582E 00
29	38	0.368335E 00	29	39	0.367513E 00	29	42	0.365201E 00
29	43	0.353537E 00	29	44	0.348199E 00	29	47	0.326710E 00
29	48	0.321045E 00	29	49	0.321125E 00	29	52	0.263514E 00
29	53	0.274519E 00	29	54	0.287741E 00	29	57	0.190012E 00
29	58	0.221886E 00	29	59	0.251687E 00	29	63	0.173327E 00
29	64	0.217261E 00	29	67	0.789934E-01	29	68	0.135202E 00
29	69	0.188148E 00	29	72	0.530193E-01	29	73	0.109969E 00
29	74	0.166239E 00	29	77	0.405042E-01	29	78	0.953302E-01
29	79	0.151951E 00	29	82	0.365067E-01	29	83	0.891021E-01
29	84	0.144606E 00	29	87	0.388814E-01	29	88	0.894850E-01
29	89	0.143368E 00	29	92	0.460920E-01	29	93	0.954483E-01
29	94	0.147589E 00	29	97	0.585777E-01	29	98	0.106885E 00
29	99	0.156850E 00	29	103	0.124697E 00	29	104	0.170617E 00
29	107	0.109886E 00	29	108	0.147859E 00	29	109	0.188056E 00
29	112	0.143905E 00	29	113	0.173816E 00	29	114	0.207753E 00
29	117	0.173436E 00	29	118	0.198382E 00	29	119	0.228271E 00
30	2	0.228005E 00	30	3	0.257406E 00	30	4	0.294457E 00
30	7	0.231665E 00	30	8	0.267988E 00	30	9	0.311202E 00
30	12	0.222976E 00	30	13	0.273304E 00	30	14	0.327132E 00
30	17	0.212319E 00	30	18	0.277810E 00	30	19	0.343848E 00
30	23	0.288741E 00	30	24	0.359690E 00	30	27	0.246658E 00
30	28	0.304759E 00	30	29	0.378247E 00	30	32	0.285849E 00
30	33	0.325944E 00	30	34	0.376495E 00	30	37	0.313313E 00
30	38	0.336122E 00	30	39	0.371656E 00	30	42	0.315702E 00
30	43	0.330750E 00	30	44	0.357189E 00	30	47	0.291568E 00
30	48	0.308892E 00	30	49	0.335354E 00	30	52	0.245380E 00
30	53	0.274404E 00	30	54	0.308219E 00	30	57	0.189299E 00
30	58	0.234413E 00	30	59	0.279302E 00	30	63	0.198594E 00
30	64	0.252289E 00	30	67	0.112616E 00	30	68	0.172289E 00
30	69	0.230153E 00	30	72	0.100566E 00	30	73	0.156771E 00
30	74	0.214014E 00	30	77	0.965995E-01	30	78	0.148350E 00
30	79	0.203707E 00	30	82	0.949829E-01	30	83	0.144412E 00
30	84	0.198292E 00	30	87	0.941360E-01	30	88	0.143495E 00

30	89	0.197121E 00	30	92	0.940419E-01	30	93	0.145753E 00
30	94	0.200151E 00	30	97	0.982293E-01	30	98	0.152771E 00
30	99	0.207806E 00	30	103	0.167484E 00	30	104	0.220238E 00
30	107	0.143328E 00	30	108	0.189466E 00	30	109	0.236941E 00
30	112	0.179455E 00	30	113	0.215548E 00	30	114	0.256219E 00
30	117	0.210012E 00	30	118	0.239499E 00	30	119	0.275982E 00
31	2	-0.125503E 00	31	3	-0.510489E-01	31	4	0.189507E-01
31	7	-0.979083E-01	31	8	-0.187073E-01	31	9	0.510411E-01
31	12	-0.283259E-01	31	13	0.446539E-01	31	14	0.101987E 00
31	17	0.930243E-01	31	18	0.142915E 00	31	19	0.171364E 00
31	23	0.274506E 00	31	24	0.252467E 00	31	27	0.502406E 00
31	28	0.415685E 00	31	29	0.332829E 00	31	32	0.699222E 00
31	33	0.530485E 00	31	34	0.396556E 00	31	37	0.776076E 00
31	38	0.588215E 00	31	39	0.429994E 00	31	42	0.739371E 00
31	43	0.575893E 00	31	44	0.427244E 00	31	47	0.626759E 00
31	48	0.506257E 00	31	49	0.390787E 00	31	52	0.466783E 00
31	53	0.400676E 00	31	54	0.329824E 00	31	57	0.292862E 00
31	58	0.280768E 00	31	59	0.256741E 00	31	63	0.167029E 00
31	64	0.183198E 00	31	67	0.151178E-01	31	68	0.736150E-01
31	69	0.118432E 00	31	72	-0.619826E-01	31	73	0.782240E-02
31	74	0.678884E-01	31	77	-0.999514E-01	31	78	-0.309340E-01
31	79	0.332665E-01	31	82	-0.108347E 00	31	83	-0.472430E-01
31	84	0.130105E-01	31	87	-0.964544E-01	31	88	-0.480007E-01
31	89	0.353020E-02	31	92	-0.753106E-01	31	93	-0.413887E-01
31	94	0.467300E-03	31	97	-0.585661E-01	31	98	-0.351818E-01
31	99	-0.280300E-03	31	103	-0.353013E-01	31	104	-0.127030E-02
31	107	-0.712199E-01	31	108	-0.425881E-01	31	109	-0.290030E-02
31	112	-0.973657E-01	31	113	-0.534417E-01	31	114	-0.299590E-02
31	117	-0.121182E 00	31	118	-0.595482E-01	31	119	0.253740E-02
32	2	-0.320239E-01	32	3	0.272220E-01	32	4	0.846207E-01
32	7	-0.952020E-02	32	8	0.546271E-01	32	9	0.112683E 00
32	12	0.403331E-01	32	13	0.103605E 00	32	14	0.154443E 00
32	17	0.127549E 00	32	18	0.178467E 00	32	19	0.210392E 00
32	23	0.281231E 00	32	24	0.276267E 00	32	27	0.444121E 00
32	28	0.397952E 00	32	29	0.341872E 00	32	32	0.606057E 00
32	33	0.500467E 00	32	34	0.391878E 00	32	37	0.670769E 00
32	38	0.537856E 00	32	39	0.418766E 00	32	42	0.639498E 00
32	43	0.523257E 00	32	44	0.413275E 00	32	47	0.553090E 00
32	48	0.464006E 00	32	49	0.379819E 00	32	52	0.420368E 00
32	53	0.374985E 00	32	54	0.326418E 00	32	57	0.273039E 00
32	58	0.272849E 00	32	59	0.263150E 00	32	63	0.175878E 00
32	64	0.199671E 00	32	67	0.379661E-01	32	68	0.964643E-01
32	69	0.143870E 00	32	72	-0.260835E-01	32	73	0.408285E-01
32	74	0.100353E 00	32	77	-0.579366E-01	32	78	0.783380E-02
32	79	0.705546E-01	32	82	-0.658920E-01	32	83	-0.641960E-02
32	84	0.532008E-01	32	87	-0.572425E-01	32	88	-0.742480E-02
32	89	0.454715E-01	32	92	-0.402861E-01	32	93	-0.132380E-02
32	94	0.440599E-01	32	97	-0.246939E-01	32	98	0.627340E-02
32	99	0.458903E-01	32	103	0.113546E-01	32	104	0.489403E-01
32	107	-0.182650E-01	32	108	0.129407E-01	32	109	0.526258E-01
32	112	-0.267030E-01	32	113	0.127599E-01	32	114	0.580165E-01
32	117	-0.349178E-01	32	118	0.154194E-01	32	119	0.675424E-01
33	2	0.551034E-01	33	3	0.102393E 00	33	4	0.150465E 00
33	7	0.724450E-01	33	8	0.125068E 00	33	9	0.174965E 00
33	12	0.103730E 00	33	13	0.160713E 00	33	14	0.208678E 00
33	17	0.159181E 00	33	18	0.214374E 00	33	19	0.253026E 00
33	23	0.289551E 00	33	24	0.306989E 00	33	27	0.377718E 00

33	28	0.392002E 00	33	29	0.362258E 00	33	32	0.506545E 00
33	33	0.464726E 00	33	34	0.409866E 00	33	37	0.557446E 00
33	38	0.500766E 00	33	39	0.419839E 00	33	42	0.546657E 00
33	43	0.474156E 00	33	44	0.408295E 00	33	47	0.480807E 00
33	48	0.426220E 00	33	49	0.375286E 00	33	52	0.375281E 00
33	53	0.352464E 00	33	54	0.328404E 00	33	57	0.254218E 00
33	58	0.267813E 00	33	59	0.274311E 00	33	63	0.187709E 00
33	64	0.220648E 00	33	67	0.631872E-01	33	68	0.122735E 00
33	69	0.173814E 00	33	72	0.132419E-01	33	73	0.778153E-01
33	74	0.137440E 00	33	77	-0.115493E-01	33	78	0.510665E-01
33	79	0.112566E 00	33	82	-0.185780E-01	33	83	0.390723E-01
33	84	0.980774E-01	33	87	-0.132603E-01	33	88	0.376430E-01
33	89	0.918603E-01	33	92	-0.127450E-02	33	93	0.426010E-01
33	94	0.916197E-01	33	97	0.117293E-01	33	98	0.505292E-01
33	99	0.953287E-01	33	103	0.594553E-01	33	104	0.101572E 00
33	107	0.332767E-01	33	108	0.684375E-01	33	109	0.109695E 00
33	112	0.404909E-01	33	113	0.775371E-01	33	114	0.119803E 00
33	117	0.461070E-01	33	118	0.878649E-01	33	119	0.132816E 00
34	2	0.129357E 00	34	3	0.168841E 00	34	4	0.211879E 00
34	7	0.140883E 00	34	8	0.186207E 00	34	9	0.232601E 00
34	12	0.154822E 00	34	13	0.208932E 00	34	14	0.258561E 00
34	17	0.181157E 00	34	18	0.241853E 00	34	19	0.291948E 00
34	23	0.291961E 00	34	24	0.333223E 00	34	27	0.312971E 00
34	28	0.352944E 00	34	29	0.389353E 00	34	32	0.392893E 00
34	33	0.414622E 00	34	34	0.403504E 00	34	37	0.445932E 00
34	38	0.431520E 00	34	39	0.428936E 00	34	42	0.448496E 00
34	43	0.422340E 00	34	44	0.401482E 00	34	47	0.405176E 00
34	48	0.385241E 00	34	49	0.371354E 00	34	52	0.326976E 00
34	53	0.328740E 00	34	54	0.331817E 00	34	57	0.234001E 00
34	58	0.262995E 00	34	59	0.287777E 00	34	63	0.201500E 00
34	64	0.244828E 00	34	67	0.919141E-01	34	68	0.152745E 00
34	69	0.207873E 00	34	72	0.584811E-01	34	73	0.120127E 00
34	74	0.179431E 00	34	77	0.425552E-01	34	78	0.100745E 00
34	79	0.159988E 00	34	82	0.372432E-01	34	83	0.914350E-01
34	84	0.148459E 00	34	87	0.388270E-01	34	88	0.891674E-01
34	89	0.143342E 00	34	92	0.442002E-01	34	93	0.917117E-01
34	94	0.143354E 00	34	97	0.518817E-01	34	98	0.979412E-01
34	99	0.147585E 00	34	103	0.108157E 00	34	104	0.155366E 00
34	107	0.812476E-01	34	108	0.121747E 00	34	109	0.166161E 00
34	112	0.100335E 00	34	113	0.137431E 00	34	114	0.179331E 00
34	117	0.116486E 00	34	118	0.153144E 00	34	119	0.194503E 00
35	2	0.187992E 00	35	3	0.224205E 00	35	4	0.266925E 00
35	7	0.192685E 00	35	8	0.235329E 00	35	9	0.283300E 00
35	12	0.190635E 00	35	13	0.245152E 00	35	14	0.301238E 00
35	17	0.191673E 00	35	18	0.258219E 00	35	19	0.322511E 00
35	23	0.280875E 00	35	24	0.347453E 00	35	27	0.254964E 00
35	28	0.311364E 00	35	29	0.372121E 00	35	32	0.308350E 00
35	33	0.341215E 00	35	34	0.396512E 00	35	37	0.345493E 00
35	38	0.362457E 00	35	39	0.395770E 00	35	42	0.353090E 00
35	43	0.362543E 00	35	44	0.386803E 00	35	47	0.328468E 00
35	48	0.341286E 00	35	49	0.365044E 00	35	52	0.276841E 00
35	53	0.303516E 00	35	54	0.335509E 00	35	57	0.212759E 00
35	58	0.258183E 00	35	59	0.302818E 00	35	63	0.216826E 00
35	64	0.271559E 00	35	67	0.123584E 00	35	68	0.185890E 00
35	69	0.245344E 00	35	72	0.108908E 00	35	73	0.167045E 00
35	74	0.225556E 00	35	77	0.103657E 00	35	78	0.156124E 00
35	79	0.212007E 00	35	82	0.100963E 00	35	83	0.149950E 00

35	84	0.203496E 00	35	87	0.985525E-01	35	88	0.146490E 00
35	89	0.199069E 00	35	92	0.957704E-01	35	93	0.145375E 00
35	94	0.198394E 00	35	97	0.953687E-01	35	98	0.147821E 00
35	99	0.201728E 00	35	103	0.156602E 00	35	104	0.209269E 00
35	107	0.124640E 00	35	108	0.171720E 00	35	109	0.220793E 00
35	112	0.151258E 00	35	113	0.190903E 00	35	114	0.235140E 00
35	117	0.174013E 00	35	118	0.209282E 00	35	119	0.250884E 00
36	2	-0.172734E 00	36	3	-0.810313E-01	36	4	0.640120E-02
36	7	-0.149099E 00	36	8	-0.488439E-01	36	9	0.410894E-01
36	12	-0.757179E-01	36	13	0.204523E-01	36	14	0.988082E-01
36	17	0.600398E-01	36	18	0.132424E 00	36	19	0.180230E 00
36	23	0.286255E 00	36	24	0.279594E 00	36	27	0.528997E 00
36	28	0.462911E 00	36	29	0.383822E 00	36	32	0.797271E 00
36	33	0.626538E 00	36	34	0.473704E 00	36	37	0.980060E 00
36	38	0.729593E 00	36	39	0.530701E 00	36	42	0.986329E 00
36	43	0.746353E 00	36	44	0.541423E 00	36	47	0.856604E 00
36	48	0.674260E 00	36	49	0.505730E 00	36	52	0.646259E 00
36	53	0.541586E 00	36	54	0.432641E 00	36	57	0.409749E 00
36	58	0.382260E 00	36	59	0.338710E 00	36	63	0.227592E 00
36	64	0.241015E 00	36	67	0.248453E-01	36	68	0.989510E-01
36	69	0.153443E 00	36	72	-0.831372E-01	36	73	0.768230E-02
36	74	0.843709E-01	36	77	-0.137420E 00	36	78	-0.466140E-01
36	79	0.367546E-01	36	82	-0.150680E 00	36	83	-0.699686E-01
36	84	0.869670E-02	36	87	-0.134937E 00	36	88	-0.712606E-01
36	89	-0.428750E-02	36	92	-0.105279E 00	36	93	-0.617041E-01
36	94	-0.820730E-02	36	97	-0.804936E-01	36	98	-0.520241E-01
36	99	-0.877100E-02	36	103	-0.505878E-01	36	104	-0.977960E-02
36	107	-0.918600E-01	36	108	-0.593198E-01	36	109	-0.122791E-01
36	112	-0.125764E 00	36	113	-0.743832E-01	36	114	-0.139781E-01
36	117	-0.159876E 00	36	118	-0.857729E-01	36	119	-0.999240E-02
37	2	-0.831897E-01	37	3	-0.835640E-02	37	4	0.645460E-01
37	7	-0.636967E-01	37	8	0.185569E-01	37	9	0.939881E-01
37	12	-0.912820E-02	37	13	0.726461E-01	37	14	0.140821E 00
37	17	0.920613E-01	37	18	0.159136E 00	37	19	0.206073E 00
37	23	0.279310E 00	37	24	0.285919E 00	37	27	0.452020E 00
37	28	0.420224E 00	37	29	0.370697E 00	37	32	0.671240E 00
37	33	0.555945E 00	37	34	0.444500E 00	37	37	0.818548E 00
37	38	0.648959E 00	37	39	0.489338E 00	37	42	0.825500E 00
37	43	0.652828E 00	37	44	0.498269E 00	37	47	0.718337E 00
37	48	0.589872E 00	37	49	0.466590E 00	37	52	0.553435E 00
37	53	0.480637E 00	37	54	0.404612E 00	37	57	0.361402E 00
37	58	0.350510E 00	37	59	0.326382E 00	37	63	0.224406E 00
37	64	0.245623E 00	37	67	0.509418E-01	37	68	0.120054E 00
37	69	0.173464E 00	37	72	-0.342952E-01	37	73	0.464740E-01
37	74	0.116535E 00	37	77	-0.772728E-01	37	78	0.236500E-02
37	79	0.770743E-01	37	82	-0.888010E-01	37	83	-0.173333E-01
37	84	0.535118E-01	37	87	-0.784844E-01	37	88	-0.198385E-01
37	89	0.421851E-01	37	92	-0.574772E-01	37	93	-0.134465E-01
37	94	0.386293E-01	37	97	-0.391323E-01	37	98	-0.585280E-02
37	99	0.386547E-01	37	103	-0.270680E-02	37	104	0.394591E-01
37	107	-0.400555E-01	37	108	-0.549080E-02	37	109	0.401758E-01
37	112	-0.584641E-01	37	113	-0.119205E-01	37	114	0.422019E-01
37	117	-0.776870E-01	37	118	-0.156970E-01	37	119	0.487916E-01
38	2	0.336770E-02	38	3	0.638097E-01	38	4	0.124738E 00
38	7	0.185531E-01	38	8	0.855864E-01	38	9	0.149334E 00
38	12	0.549505E-01	38	13	0.125232E 00	38	14	0.186142E 00
38	17	0.123191E 00	38	18	0.187674E 00	38	19	0.236634E 00

38	23	0.276597E 00	38	24	0.298906E 00	38	27	0.383155E 00
38	28	0.382290E 00	38	29	0.367663E 00	38	32	0.539794E 00
38	33	0.500878E 00	38	34	0.429542E 00	38	37	0.654865E 00
38	38	0.565877E 00	38	39	0.473459E 00	38	42	0.660106E 00
38	43	0.575497E 00	38	44	0.469825E 00	38	47	0.590324E 00
38	48	0.511678E 00	38	49	0.438625E 00	38	52	0.464556E 00
38	53	0.426317E 00	38	54	0.384841E 00	38	57	0.316097E 00
38	58	0.323480E 00	38	59	0.320838E 00	38	63	0.224964E 00
38	64	0.255903E 00	38	67	0.784070E-01	38	68	0.144314E 00
38	69	0.198429E 00	38	72	0.159738E-01	38	73	0.882085E-01
38	74	0.153196E 00	38	77	-0.153207E-01	38	78	0.543078E-01
38	79	0.121635E 00	38	82	-0.248785E-01	38	83	0.382363E-01
38	84	0.102317E 00	38	87	-0.197576E-01	38	88	0.345262E-01
38	89	0.924753E-01	38	92	-0.749800E-02	38	93	0.375792E-01
38	94	0.890559E-01	38	97	0.390030E-02	38	98	0.426792E-01
38	99	0.893593E-01	38	103	0.469359E-01	38	104	0.915927E-01
38	107	0.115718E-01	38	108	0.493837E-01	38	109	0.951167E-01
38	112	0.753990E-02	38	113	0.508601E-01	38	114	0.100507E 00
38	117	0.212020E-02	38	118	0.540775E-01	38	119	0.109483E 00
39	2	0.836895E-01	39	3	0.132953E 00	39	4	0.185246E 00
39	7	0.940850E-01	39	8	0.149433E 00	39	9	0.205193E 00
39	12	0.113062E 00	39	13	0.175221E 00	39	14	0.232660E 00
39	17	0.150462E 00	39	18	0.215034E 00	39	19	0.269422E 00
39	23	0.273891E 00	39	24	0.315312E 00	39	27	0.316494E 00
39	28	0.347651E 00	39	29	0.367563E 00	39	32	0.420437E 00
39	33	0.421931E 00	39	34	0.428957E 00	39	37	0.490159E 00
39	38	0.478147E 00	39	39	0.440861E 00	39	42	0.508787E 00
39	43	0.475590E 00	39	44	0.456733E 00	39	47	0.467554E 00
39	48	0.439365E 00	39	49	0.415544E 00	39	52	0.380613E 00
39	53	0.375801E 00	39	54	0.371379E 00	39	57	0.273341E 00
39	58	0.300365E 00	39	59	0.321186E 00	39	63	0.228868E 00
39	64	0.271611E 00	39	67	0.107275E 00	39	68	0.171723E 00
39	69	0.228405E 00	39	72	0.680398E-01	39	73	0.133165E 00
39	74	0.194607E 00	39	77	0.491290E-01	39	78	0.109716E 00
39	79	0.170789E 00	39	82	0.421629E-01	39	83	0.974876E-01
39	84	0.155579E 00	39	87	0.423461E-01	39	88	0.925683E-01
39	89	0.147000E 00	39	92	0.455588E-01	39	93	0.919307E-01
39	94	0.143340E 00	39	97	0.490682E-01	39	98	0.937917E-01
39	99	0.143368E 00	39	103	0.980912E-01	39	104	0.146330E 00
39	107	0.621132E-01	39	108	0.104501E 00	39	109	0.151892E 00
39	112	0.705332E-01	39	113	0.112572E 00	39	114	0.159916E 00
39	117	0.770581E-01	39	118	0.121613E 00	39	119	0.170726E 00
40	2	0.154933E 00	40	3	0.196616E 00	40	4	0.243991E 00
40	7	0.159769E 00	40	8	0.207375E 00	40	9	0.259278E 00
40	12	0.162166E 00	40	13	0.219763E 00	40	14	0.277829E 00
40	17	0.171439E 00	40	18	0.238162E 00	40	19	0.301386E 00
40	23	0.268445E 00	40	24	0.330324E 00	40	27	0.255729E 00
40	28	0.308288E 00	40	29	0.362736E 00	40	32	0.318811E 00
40	33	0.349339E 00	40	34	0.391366E 00	40	37	0.365282E 00
40	38	0.375898E 00	40	39	0.414732E 00	40	42	0.378183E 00
40	43	0.384004E 00	40	44	0.408022E 00	40	47	0.355512E 00
40	48	0.365993E 00	40	49	0.390453E 00	40	52	0.301817E 00
40	53	0.327905E 00	40	54	0.360447E 00	40	57	0.233160E 00
40	58	0.279856E 00	40	59	0.325648E 00	40	63	0.235280E 00
40	64	0.291600E 00	40	67	0.137065E 00	40	68	0.201596E 00
40	69	0.262533E 00	40	72	0.121501E 00	40	73	0.180784E 00
40	74	0.240037E 00	40	77	0.115827E 00	40	78	0.168139E 00

40	79	0.223870E 00	40	82	0.112173E 00	40	83	0.160006E 00
40	84	0.212611E 00	40	87	0.107765E 00	40	88	0.153900E 00
40	89	0.205051E 00	40	92	0.101613E 00	40	93	0.149164E 00
40	94	0.200700E 00	40	97	0.961178E-01	40	98	0.146879E 00
40	99	0.199765E 00	40	103	0.149875E 00	40	104	0.202559E 00
40	107	0.110441E 00	40	108	0.158597E 00	40	109	0.209141E 00
40	112	0.128759E 00	40	113	0.171512E 00	40	114	0.218799E 00
40	117	0.144733E 00	40	118	0.184765E 00	40	119	0.230623E 00
41	2	-0.177237E 00	41	3	-0.845910E-01	41	4	0.473130E-02
41	7	-0.158762E 00	41	8	-0.557187E-01	41	9	0.378539E-01
41	12	-0.913933E-01	41	13	0.981440E-02	41	14	0.939797E-01
41	17	0.384398E-01	41	18	0.118295E 00	41	19	0.174545E 00
41	23	0.269520E 00	41	24	0.275177E 00	41	27	0.493956E 00
41	28	0.448034E 00	41	29	0.384784E 00	41	32	0.767229E 00
41	33	0.625463E 00	41	34	0.485480E 00	41	37	0.994001E 00
41	38	0.759272E 00	41	39	0.556992E 00	41	42	0.108968E 01
41	43	0.808442E 00	41	44	0.583088E 00	41	47	0.994030E 00
41	48	0.759242E 00	41	49	0.556936E 00	41	52	0.767186E 00
41	53	0.625504E 00	41	54	0.485399E 00	41	57	0.493869E 00
41	58	0.447980E 00	41	59	0.384756E 00	41	63	0.269392E 00
41	64	0.275176E 00	41	67	0.383701E-01	41	68	0.118239E 00
41	69	0.174511E 00	41	72	-0.914114E-01	41	73	0.981710E-02
41	74	0.939088E-01	41	77	-0.158778E 00	41	78	-0.557527E-01
41	79	0.377959E-01	41	82	-0.177234E 00	41	83	-0.845888E-01
41	84	0.473270E-02	41	87	-0.160565E 00	41	88	-0.868629E-01
41	89	-0.104163E-01	41	92	-0.125446E 00	41	93	-0.749949E-01
41	94	-0.142516E-01	41	97	-0.934151E-01	41	98	-0.613071E-01
41	99	-0.133894E-01	41	103	-0.557261E-01	41	104	-0.125201E-01
41	107	-0.934623E-01	41	108	-0.613513E-01	41	109	-0.134344E-01
41	112	-0.125576E 00	41	113	-0.750625E-01	41	114	-0.143232E-01
41	117	-0.160730E 00	41	118	-0.869861E-01	41	119	-0.104920E-01
42	2	-0.986202E-01	42	3	-0.206662E-01	42	4	0.558724E-01
42	7	-0.830281E-01	42	8	0.348970E-02	42	9	0.836936E-01
42	12	-0.315141E-01	42	13	0.553867E-01	42	14	0.129403E 00
42	17	0.677922E-01	42	18	0.140555E 00	42	19	0.194425E 00
42	23	0.260240E 00	42	24	0.275661E 00	42	27	0.425689E 00
42	28	0.402626E 00	42	29	0.364770E 00	42	32	0.640064E 00
42	33	0.546382E 00	42	34	0.447687E 00	42	37	0.825641E 00
42	38	0.658629E 00	42	39	0.507458E 00	42	42	0.901787E 00
42	43	0.708097E 00	42	44	0.527841E 00	42	47	0.825570E 00
42	48	0.658548E 00	42	49	0.507376E 00	42	52	0.639971E 00
42	53	0.546364E 00	42	54	0.447595E 00	42	57	0.425578E 00
42	58	0.402555E 00	42	59	0.364730E 00	42	63	0.260128E 00
42	64	0.275650E 00	42	67	0.677567E-01	42	68	0.140518E 00
42	69	0.194396E 00	42	72	-0.314999E-01	42	73	0.554075E-01
42	74	0.129352E 00	42	77	-0.830064E-01	42	78	0.348490E-02
42	79	0.836582E-01	42	82	-0.986175E-01	42	83	-0.206643E-01
42	84	0.558736E-01	42	87	-0.889097E-01	42	88	-0.250261E-01
42	89	0.419755E-01	42	92	-0.662281E-01	42	93	-0.188150E-01
42	94	0.370320E-01	42	97	-0.457043E-01	42	98	-0.107414E-01
42	99	0.362869E-01	42	103	-0.737300E-02	42	104	0.364363E-01
42	107	-0.457244E-01	42	108	-0.107671E-01	42	109	0.362536E-01
42	112	-0.663080E-01	42	113	-0.188509E-01	42	114	0.369837E-01
42	117	-0.890137E-01	42	118	-0.251037E-01	42	119	0.419292E-01
43	2	-0.206575E-01	43	3	0.444144E-01	43	4	0.110096E 00
43	7	-0.822450E-02	43	8	0.639105E-01	43	9	0.132941E 00
43	12	0.276486E-01	43	13	0.102635E 00	43	14	0.168872E 00

43	17	0.974203E-01	43	18	0.165522E 00	43	19	0.219379E 00
43	23	0.255238E 00	43	24	0.282711E 00	43	27	0.361580E 00
43	28	0.364021E 00	43	29	0.353234E 00	43	32	0.524178E 00
43	33	0.474338E 00	43	34	0.421725E 00	43	37	0.654596E 00
43	38	0.575622E 00	43	39	0.473687E 00	43	42	0.714011E 00
43	43	0.607062E 00	43	44	0.499349E 00	43	47	0.654505E 00
43	48	0.575547E 00	43	49	0.473626E 00	43	52	0.524078E 00
43	53	0.474304E 00	43	54	0.421660E 00	43	57	0.361468E 00
43	58	0.363959E 00	43	59	0.353214E 00	43	63	0.255156E 00
43	64	0.282712E 00	43	67	0.974146E-01	43	68	0.165506E 00
43	69	0.219366E 00	43	72	0.276829E-01	43	73	0.102673E 00
43	74	0.168848E 00	43	77	-0.818100E-02	43	78	0.639293E-01
43	79	0.132932E 00	43	82	-0.206554E-01	43	83	0.444160E-01
43	84	0.110097E 00	43	87	-0.173850E-01	43	88	0.381415E-01
43	89	0.973333E-01	43	92	-0.660860E-02	43	93	0.389322E-01
43	94	0.912745E-01	43	97	0.273980E-02	43	98	0.415633E-01
43	99	0.889475E-01	43	103	0.427795E-01	43	104	0.883880E-01
43	107	0.273650E-02	43	108	0.415480E-01	43	109	0.889201E-01
43	112	-0.665920E-02	43	113	0.389131E-01	43	114	0.912389E-01
43	117	-0.174550E-01	43	118	0.380891E-01	43	119	0.973027E-01
44	2	0.559762E-01	44	3	0.110193E 00	44	4	0.167207E 00
44	7	0.647427E-01	44	8	0.124912E 00	44	9	0.185316E 00
44	12	0.850574E-01	44	13	0.150763E 00	44	14	0.212001E 00
44	17	0.126283E 00	44	18	0.192195E 00	44	19	0.248841E 00
44	23	0.253320E 00	44	24	0.295288E 00	44	27	0.302370E 00
44	28	0.329309E 00	44	29	0.348261E 00	44	32	0.414484E 00
44	33	0.409134E 00	44	34	0.401539E 00	44	37	0.499727E 00
44	38	0.471845E 00	44	39	0.456773E 00	44	42	0.528637E 00
44	43	0.504016E 00	44	44	0.456187E 00	44	47	0.499738E 00
44	48	0.471843E 00	44	49	0.456748E 00	44	52	0.414472E 00
44	53	0.409140E 00	44	54	0.401518E 00	44	57	0.302314E 00
44	58	0.329290E 00	44	59	0.348269E 00	44	63	0.253276E 00
44	64	0.295296E 00	44	67	0.126293E 00	44	68	0.192187E 00
44	69	0.248825E 00	44	72	0.850739E-01	44	73	0.150786E 00
44	74	0.211972E 00	44	77	0.647563E-01	44	78	0.124911E 00
44	79	0.185296E 00	44	82	0.559776E-01	44	83	0.110194E 00
44	84	0.167207E 00	44	87	0.535921E-01	44	88	0.102352E 00
44	89	0.155538E 00	44	92	0.532181E-01	44	93	0.981024E-01
44	94	0.148424E 00	44	97	0.518628E-01	44	98	0.955566E-01
44	99	0.144587E 00	44	103	0.947165E-01	44	104	0.143349E 00
44	107	0.518787E-01	44	108	0.955536E-01	44	109	0.144567E 00
44	112	0.532002E-01	44	113	0.981044E-01	44	114	0.148405E 00
44	117	0.535616E-01	44	118	0.102331E 00	44	119	0.155530E 00
45	2	0.129723E 00	45	3	0.175253E 00	45	4	0.225913E 00
45	7	0.134137E 00	45	8	0.184965E 00	45	9	0.239478E 00
45	12	0.139008E 00	45	13	0.198208E 00	45	14	0.257402E 00
45	17	0.153015E 00	45	18	0.219090E 00	45	19	0.281283E 00
45	23	0.252857E 00	45	24	0.311436E 00	45	27	0.248229E 00
45	28	0.297317E 00	45	29	0.346135E 00	45	32	0.316758E 00
45	33	0.344193E 00	45	34	0.380544E 00	45	37	0.368535E 00
45	38	0.378913E 00	45	39	0.406286E 00	45	42	0.387546E 00
45	43	0.390023E 00	45	44	0.422257E 00	45	47	0.368476E 00
45	48	0.378866E 00	45	49	0.406248E 00	45	52	0.316696E 00
45	53	0.344148E 00	45	54	0.380521E 00	45	57	0.248146E 00
45	58	0.297280E 00	45	59	0.346140E 00	45	63	0.252824E 00
45	64	0.311439E 00	45	67	0.153048E 00	45	68	0.219095E 00
45	69	0.281271E 00	45	72	0.139043E 00	45	73	0.198245E 00

45	74	0.257391E 00	45	77	0.134172E 00	45	78	0.184985E 00
45	79	0.239480E 00	45	82	0.129724E 00	45	83	0.175253E 00
45	84	0.225914E 00	45	87	0.122751E 00	45	88	0.166361E 00
45	89	0.215370E 00	45	92	0.112288E 00	45	93	0.157626E 00
45	94	0.207334E 00	45	97	0.100930E 00	45	98	0.150300E 00
45	99	0.202114E 00	45	103	0.147543E 00	45	104	0.200243E 00
45	107	0.100951E 00	45	108	0.150297E 00	45	109	0.202092E 00
45	112	0.112275E 00	45	113	0.157627E 00	45	114	0.207312E 00
45	117	0.122722E 00	45	118	0.166339E 00	45	119	0.215358E 00
46	2	-0.150682E 00	46	3	-0.699703E-01	46	4	0.869560E-02
46	7	-0.137634E 00	46	8	-0.467574E-01	46	9	0.366779E-01
46	12	-0.832999E-01	46	13	0.755160E-02	46	14	0.843422E-01
46	17	0.248234E-01	46	18	0.989479E-01	46	19	0.153436E 00
46	23	0.227757E 00	46	24	0.241044E 00	46	27	0.410074E 00
46	28	0.382485E 00	46	29	0.338833E 00	46	32	0.646733E 00
46	33	0.541851E 00	46	34	0.432876E 00	46	37	0.857176E 00
46	38	0.674670E 00	46	39	0.505992E 00	46	42	0.986328E 00
46	43	0.746352E 00	46	44	0.541422E 00	46	47	0.979743E 00
46	48	0.729325E 00	46	49	0.530482E 00	46	52	0.797113E 00
46	53	0.626434E 00	46	54	0.473494E 00	46	57	0.528883E 00
46	58	0.462790E 00	46	59	0.383702E 00	46	63	0.286105E 00
46	64	0.279544E 00	46	67	0.600127E-01	46	68	0.132378E 00
46	69	0.180177E 00	46	72	-0.756701E-01	46	73	0.204826E-01
46	74	0.987337E-01	46	77	-0.149044E 00	46	78	-0.488413E-01
46	79	0.410351E-01	46	82	-0.172730E 00	46	83	-0.810283E-01
46	84	0.640300E-02	46	87	-0.159533E 00	46	88	-0.854881E-01
46	89	-0.976750E-02	46	92	-0.125485E 00	46	93	-0.741658E-01
46	94	-0.137591E-01	46	97	-0.916884E-01	46	98	-0.591383E-01
46	99	-0.120910E-01	46	103	-0.504553E-01	46	104	-0.963850E-02
46	107	-0.804231E-01	46	108	-0.519339E-01	46	109	-0.867190E-02
46	112	-0.105266E 00	46	113	-0.616283E-01	46	114	-0.812980E-02
46	117	-0.134934E 00	46	118	-0.712240E-01	46	119	-0.421190E-02
47	2	-0.888029E-01	47	3	-0.173348E-01	47	4	0.535109E-01
47	7	-0.773149E-01	47	8	0.234340E-02	47	9	0.770766E-01
47	12	-0.343307E-01	47	13	0.464283E-01	47	14	0.116552E 00
47	17	0.509498E-01	47	18	0.120061E 00	47	19	0.173462E 00
47	23	0.224479E 00	47	24	0.245601E 00	47	27	0.361485E 00
47	28	0.350549E 00	47	29	0.326382E 00	47	32	0.553500E 00
47	33	0.480628E 00	47	34	0.404660E 00	47	37	0.718370E 00
47	38	0.589914E 00	47	39	0.466634E 00	47	42	0.825499E 00
47	43	0.652828E 00	47	44	0.498268E 00	47	47	0.818505E 00
47	48	0.648912E 00	47	49	0.489289E 00	47	52	0.671164E 00
47	53	0.555946E 00	47	54	0.444422E 00	47	57	0.451912E 00
47	58	0.420156E 00	47	59	0.370657E 00	47	63	0.279191E 00
47	64	0.285904E 00	47	67	0.920055E-01	47	68	0.159084E 00
47	69	0.206037E 00	47	72	-0.913630E-02	47	73	0.726482E-01
47	74	0.140759E 00	47	77	-0.636972E-01	47	78	0.185336E-01
47	79	0.939383E-01	47	82	-0.831861E-01	47	83	-0.835370E-02
47	84	0.645477E-01	47	87	-0.775512E-01	47	88	-0.155882E-01
47	89	0.488689E-01	47	92	-0.583577E-01	47	93	-0.118539E-01
47	94	0.422816E-01	47	97	-0.400111E-01	47	98	-0.543620E-02
47	99	0.402411E-01	47	103	-0.267710E-02	47	104	0.394923E-01
47	107	-0.391236E-01	47	108	-0.584590E-02	47	109	0.386569E-01
47	112	-0.575192E-01	47	113	-0.134464E-01	47	114	0.386181E-01
47	117	-0.785429E-01	47	118	-0.198747E-01	47	119	0.421761E-01
48	2	-0.248802E-01	48	3	0.382351E-01	48	4	0.102316E 00
48	7	-0.153426E-01	48	8	0.543026E-01	48	9	0.121649E 00

48	12	0.159538E-01	48	13	0.881793E-01	48	14	0.153224E 00
48	17	0.784113E-01	48	18	0.144326E 00	48	19	0.198441E 00
48	23	0.225026E 00	48	24	0.255894E 00	48	27	0.316171E 00
48	28	0.323515E 00	48	29	0.320840E 00	48	32	0.464601E 00
48	33	0.426317E 00	48	34	0.384881E 00	48	37	0.590342E 00
48	38	0.511708E 00	48	39	0.438666E 00	48	42	0.660105E 00
48	43	0.575496E 00	48	44	0.469824E 00	48	47	0.654819E 00
48	48	0.565833E 00	48	49	0.473417E 00	48	52	0.539738E 00
48	53	0.500868E 00	48	54	0.429484E 00	48	57	0.383066E 00
48	58	0.382241E 00	48	59	0.367642E 00	48	63	0.276518E 00
48	64	0.298903E 00	48	67	0.123179E 00	48	68	0.187651E 00
48	69	0.236613E 00	48	72	0.549691E-01	48	73	0.125255E 00
48	74	0.186105E 00	48	77	0.185766E-01	48	78	0.855870E-01
48	79	0.149308E 00	48	82	0.337030E-02	48	83	0.638115E-01
48	84	0.124739E 00	48	87	0.219060E-02	48	88	0.541308E-01
48	89	0.109515E 00	48	92	0.759070E-02	48	93	0.508831E-01
48	94	0.100545E 00	48	97	0.115766E-01	48	98	0.494029E-01
48	99	0.951501E-01	48	103	0.469405E-01	48	104	0.916013E-01
48	107	0.390390E-02	48	108	0.426724E-01	48	109	0.893422E-01
48	112	-0.753620E-02	48	113	0.375718E-01	48	114	0.890312E-01
48	117	-0.198115E-01	48	118	0.344879E-01	48	119	0.924563E-01
49	2	0.421616E-01	49	3	0.974867E-01	49	4	0.155578E 00
49	7	0.491313E-01	49	8	0.109730E 00	49	9	0.170818E 00
49	12	0.680379E-01	49	13	0.133155E 00	49	14	0.194646E 00
49	17	0.107277E 00	49	18	0.171742E 00	49	19	0.228432E 00
49	23	0.228920E 00	49	24	0.271616E 00	49	27	0.273404E 00
49	28	0.300394E 00	49	29	0.321189E 00	49	32	0.380634E 00
49	33	0.375805E 00	49	34	0.371409E 00	49	37	0.467545E 00
49	38	0.439374E 00	49	39	0.415581E 00	49	42	0.508786E 00
49	43	0.475589E 00	49	44	0.456733E 00	49	47	0.490110E 00
49	48	0.478104E 00	49	49	0.440826E 00	49	52	0.420390E 00
49	53	0.421912E 00	49	54	0.428931E 00	49	57	0.316421E 00
49	58	0.347624E 00	49	59	0.367572E 00	49	63	0.273853E 00
49	64	0.315326E 00	49	67	0.150492E 00	49	68	0.215042E 00
49	69	0.269421E 00	49	72	0.113109E 00	49	73	0.175267E 00
49	74	0.232651E 00	49	77	0.941350E-01	49	78	0.149460E 00
49	79	0.205193E 00	49	82	0.836914E-01	49	83	0.132954E 00
49	84	0.185247E 00	49	87	0.770653E-01	49	88	0.121613E 00
49	89	0.170715E 00	49	92	0.705304E-01	49	93	0.112552E 00
49	94	0.159916E 00	49	97	0.620794E-01	49	98	0.104486E 00
49	99	0.151895E 00	49	103	0.980724E-01	49	104	0.146315E 00
49	107	0.490679E-01	49	108	0.937721E-01	49	109	0.143333E 00
49	112	0.455242E-01	49	113	0.919164E-01	49	114	0.143303E 00
49	117	0.422965E-01	49	118	0.925283E-01	49	119	0.146972E 00
50	2	0.112173E 00	50	3	0.160005E 00	50	4	0.212611E 00
50	7	0.115809E 00	50	8	0.168131E 00	50	9	0.223875E 00
50	12	0.121478E 00	50	13	0.180755E 00	50	14	0.240053E 00
50	17	0.137036E 00	50	18	0.201593E 00	50	19	0.262546E 00
50	23	0.235305E 00	50	24	0.291593E 00	50	27	0.233218E 00
50	28	0.279874E 00	50	29	0.325633E 00	50	32	0.301842E 00
50	33	0.327921E 00	50	34	0.360454E 00	50	37	0.355522E 00
50	38	0.366005E 00	50	39	0.390472E 00	50	42	0.378183E 00
50	43	0.384004E 00	50	44	0.408022E 00	50	47	0.365257E 00
50	48	0.375878E 00	50	49	0.414716E 00	50	52	0.318777E 00
50	53	0.349314E 00	50	54	0.391360E 00	50	57	0.255665E 00
50	58	0.308267E 00	50	59	0.362752E 00	50	63	0.268423E 00
50	64	0.330331E 00	50	67	0.171477E 00	50	68	0.238170E 00

50	69	0.301374E 00	50	72	0.162198E 00	50	73	0.219798E 00
50	74	0.277815E 00	50	77	0.159799E 00	50	78	0.207390E 00
50	79	0.259274E 00	50	82	0.154934E 00	50	83	0.196617E 00
50	84	0.243992E 00	50	87	0.144745E 00	50	88	0.184773E 00
50	89	0.230622E 00	50	92	0.128759E 00	50	93	0.171502E 00
50	94	0.218810E 00	50	97	0.110410E 00	50	98	0.158592E 00
50	99	0.209158E 00	50	103	0.149870E 00	50	104	0.202559E 00
50	107	0.961417E-01	50	108	0.146879E 00	50	109	0.199746E 00
50	112	0.101610E 00	50	113	0.149174E 00	50	114	0.200683E 00
50	117	0.107751E 00	50	118	0.153888E 00	50	119	0.205045E 00
51	2	-0.108348E 00	51	3	-0.472441E-01	51	4	0.130099E-01
51	7	-0.999939E-01	51	8	-0.309475E-01	51	9	0.332851E-01
51	12	-0.620156E-01	51	13	0.779160E-02	51	14	0.679227E-01
51	17	0.151326E-01	51	18	0.736362E-01	51	19	0.118454E 00
51	23	0.167118E 00	51	24	0.183209E 00	51	27	0.292962E 00
51	28	0.280836E 00	51	29	0.256780E 00	51	32	0.466888E 00
51	33	0.400713E 00	51	34	0.329916E 00	51	37	0.626845E 00
51	38	0.506352E 00	51	39	0.390885E 00	51	42	0.739367E 00
51	43	0.575890E 00	51	44	0.427242E 00	51	47	0.775827E 00
51	48	0.588038E 00	51	49	0.429858E 00	51	52	0.699018E 00
51	53	0.530384E 00	51	54	0.396393E 00	51	57	0.502241E 00
51	58	0.415542E 00	51	59	0.332709E 00	51	63	0.274333E 00
51	64	0.252398E 00	51	67	0.929422E-01	51	68	0.142831E 00
51	69	0.171294E 00	51	72	-0.283303E-01	51	73	0.446396E-01
51	74	0.101898E 00	51	77	-0.978942E-01	51	78	-0.187358E-01
51	79	0.509695E-01	51	82	-0.125499E 00	51	83	-0.510458E-01
51	84	0.189527E-01	51	87	-0.121101E 00	51	88	-0.594836E-01
51	89	0.258040E-02	51	92	-0.973018E-01	51	93	-0.534124E-01
51	94	-0.294840E-02	51	97	-0.712010E-01	51	98	-0.425627E-01
51	99	-0.286490E-02	51	103	-0.352933E-01	51	104	-0.126120E-02
51	107	-0.585787E-01	51	108	-0.351948E-01	51	109	-0.295600E-03
51	112	-0.753705E-01	51	113	-0.414098E-01	51	114	0.441000E-03
51	117	-0.965307E-01	51	118	-0.480533E-01	51	119	0.350560E-02
52	2	-0.658931E-01	52	3	-0.642040E-02	52	4	0.532003E-01
52	7	-0.579470E-01	52	8	0.783590E-02	52	9	0.705729E-01
52	12	-0.260940E-01	52	13	0.408065E-01	52	14	0.100381E 00
52	17	0.379780E-01	52	18	0.964780E-01	52	19	0.143881E 00
52	23	0.175935E 00	52	24	0.199660E 00	52	27	0.273093E 00
52	28	0.272872E 00	52	29	0.263149E 00	52	32	0.420392E 00
52	33	0.374967E 00	52	34	0.326451E 00	52	37	0.553074E 00
52	38	0.464017E 00	52	39	0.379851E 00	52	42	0.639496E 00
52	43	0.523255E 00	52	44	0.413273E 00	52	47	0.670697E 00
52	48	0.537800E 00	52	49	0.418718E 00	52	52	0.606006E 00
52	53	0.500464E 00	52	54	0.391804E 00	52	57	0.444036E 00
52	58	0.397897E 00	52	59	0.341827E 00	52	63	0.281131E 00
52	64	0.276249E 00	52	67	0.127505E 00	52	68	0.178422E 00
52	69	0.210360E 00	52	72	0.403331E-01	52	73	0.103606E 00
52	74	0.154389E 00	52	77	-0.951250E-02	52	78	0.546091E-01
52	79	0.112637E 00	52	82	-0.320204E-01	52	83	0.272245E-01
52	84	0.846223E-01	52	87	-0.348334E-01	52	88	0.154838E-01
52	89	0.675827E-01	52	92	-0.266402E-01	52	93	0.127930E-01
52	94	0.580617E-01	52	97	-0.182497E-01	52	98	0.129663E-01
52	99	0.526630E-01	52	103	0.113614E-01	52	104	0.489525E-01
52	107	-0.246993E-01	52	108	0.626440E-02	52	109	0.458769E-01
52	112	-0.403345E-01	52	113	-0.133740E-02	52	114	0.440359E-01
52	117	-0.573072E-01	52	118	-0.746930E-02	52	119	0.454504E-01
53	2	-0.185790E-01	53	3	0.390716E-01	53	4	0.980770E-01

53	7	-0.115571E-01	53	8	0.510667E-01	53	9	0.112577E 00
53	12	0.132301E-01	53	13	0.777889E-01	53	14	0.137459E 00
53	17	0.631832E-01	53	18	0.122736E 00	53	19	0.173816E 00
53	23	0.187742E 00	53	24	0.220624E 00	53	27	0.254248E 00
53	28	0.267812E 00	53	29	0.274286E 00	53	32	0.375267E 00
53	33	0.352425E 00	53	34	0.328405E 00	53	37	0.480753E 00
53	38	0.426193E 00	53	39	0.375288E 00	53	42	0.546655E 00
53	43	0.474155E 00	53	44	0.408294E 00	53	47	0.557449E 00
53	48	0.500755E 00	53	49	0.419819E 00	53	52	0.506543E 00
53	53	0.464738E 00	53	54	0.409819E 00	53	57	0.377656E 00
53	58	0.391965E 00	53	59	0.362229E 00	53	63	0.289478E 00
53	64	0.306976E 00	53	67	0.159164E 00	53	68	0.214343E 00
53	69	0.252995E 00	53	72	0.103729E 00	53	73	0.160714E 00
53	74	0.208628E 00	53	77	0.724431E-01	53	78	0.125046E 00
53	79	0.174920E 00	53	82	0.551062E-01	53	83	0.102395E 00
53	84	0.150466E 00	53	87	0.461687E-01	53	88	0.879137E-01
53	89	0.132848E 00	53	92	0.405347E-01	53	93	0.775627E-01
53	94	0.119844E 00	53	97	0.332800E-01	53	98	0.684596E-01
53	99	0.109736E 00	53	103	0.594654E-01	53	104	0.101593E 00
53	107	0.117437E-01	53	108	0.505352E-01	53	109	0.953273E-01
53	112	-0.129160E-02	53	113	0.426117E-01	53	114	0.916124E-01
53	117	-0.132883E-01	53	118	0.376274E-01	53	119	0.918600E-01
54	2	0.372424E-01	54	3	0.914344E-01	54	4	0.148459E 00
54	7	0.425446E-01	54	8	0.100745E 00	54	9	0.160002E 00
54	12	0.584689E-01	54	13	0.120107E 00	54	14	0.179458E 00
54	17	0.919077E-01	54	18	0.152756E 00	54	19	0.207894E 00
54	23	0.201548E 00	54	24	0.244832E 00	54	27	0.234074E 00
54	28	0.263032E 00	54	29	0.287782E 00	54	32	0.327024E 00
54	33	0.328765E 00	54	34	0.331851E 00	54	37	0.405207E 00
54	38	0.385277E 00	54	39	0.371399E 00	54	42	0.448495E 00
54	43	0.422339E 00	54	44	0.401481E 00	54	47	0.445854E 00
54	48	0.431462E 00	54	49	0.428909E 00	54	52	0.392819E 00
54	53	0.414575E 00	54	54	0.403470E 00	54	57	0.312881E 00
54	58	0.352905E 00	54	59	0.389356E 00	54	63	0.291924E 00
54	64	0.333236E 00	54	67	0.181193E 00	54	68	0.241865E 00
54	69	0.291952E 00	54	72	0.154877E 00	54	73	0.208983E 00
54	74	0.258562E 00	54	77	0.140945E 00	54	78	0.186245E 00
54	79	0.232612E 00	54	82	0.129359E 00	54	83	0.168843E 00
54	84	0.211880E 00	54	87	0.116511E 00	54	88	0.153158E 00
54	89	0.194501E 00	54	92	0.100344E 00	54	93	0.137425E 00
54	94	0.179338E 00	54	97	0.812210E-01	54	98	0.121740E 00
54	99	0.166174E 00	54	103	0.108143E 00	54	104	0.155360E 00
54	107	0.518875E-01	54	108	0.979289E-01	54	109	0.147558E 00
54	112	0.441766E-01	54	113	0.917068E-01	54	114	0.143323E 00
54	117	0.387905E-01	54	118	0.891369E-01	54	119	0.143319E 00
55	2	0.100962E 00	55	3	0.149950E 00	55	4	0.203496E 00
55	7	0.103635E 00	55	8	0.156109E 00	55	9	0.212003E 00
55	12	0.108880E 00	55	13	0.167008E 00	55	14	0.225560E 00
55	17	0.123546E 00	55	18	0.185874E 00	55	19	0.245342E 00
55	23	0.216832E 00	55	24	0.271534E 00	55	27	0.212793E 00
55	28	0.258178E 00	55	29	0.302781E 00	55	32	0.276835E 00
55	33	0.303505E 00	55	34	0.335491E 00	55	37	0.328443E 00
55	38	0.341268E 00	55	39	0.365038E 00	55	42	0.353089E 00
55	43	0.362543E 00	55	44	0.386802E 00	55	47	0.345507E 00
55	48	0.362466E 00	55	49	0.395779E 00	55	52	0.308348E 00
55	53	0.341211E 00	55	54	0.396519E 00	55	57	0.254920E 00
55	58	0.311356E 00	55	59	0.372137E 00	55	63	0.280857E 00

55	64	0.347451E 00	55	67	0.191703E 00	55	68	0.258215E 00
55	69	0.322483E 00	55	72	0.190645E 00	55	73	0.245164E 00
55	74	0.301205E 00	55	77	0.192685E 00	55	78	0.235319E 00
55	79	0.283274E 00	55	82	0.187994E 00	55	83	0.224206E 00
55	84	0.266925E 00	55	87	0.174030E 00	55	88	0.209293E 00
55	89	0.250888E 00	55	92	0.151262E 00	55	93	0.190900E 00
55	94	0.235157E 00	55	97	0.124612E 00	55	98	0.171722E 00
55	99	0.220821E 00	55	103	0.156604E 00	55	104	0.209283E 00
55	107	0.954047E-01	55	108	0.147835E 00	55	109	0.201724E 00
55	112	0.957870E-01	55	113	0.145404E 00	55	114	0.198393E 00
55	117	0.985628E-01	55	118	0.146500E 00	55	119	0.199080E 00
56	2	-0.663341E-01	56	3	-0.263390E-01	56	4	0.135802E-01
56	7	-0.609386E-01	56	8	-0.170252E-01	56	9	0.247872E-01
56	12	-0.386449E-01	56	13	0.521790E-02	56	14	0.444809E-01
56	17	0.537110E-02	56	18	0.427131E-01	56	19	0.734019E-01
56	23	0.956032E-01	56	24	0.110671E 00	56	27	0.160718E 00
56	28	0.160120E 00	56	29	0.153528E 00	56	32	0.258267E 00
56	33	0.229154E 00	56	34	0.197298E 00	56	37	0.350364E 00
56	38	0.292497E 00	56	39	0.236064E 00	56	42	0.419889E 00
56	43	0.339294E 00	56	44	0.263284E 00	56	47	0.454719E 00
56	48	0.360403E 00	56	49	0.274125E 00	56	52	0.443266E 00
56	53	0.348691E 00	56	54	0.265222E 00	56	57	0.378412E 00
56	58	0.300813E 00	56	59	0.237894E 00	56	63	0.229011E 00
56	64	0.197312E 00	56	67	0.141552E 00	56	68	0.152609E 00
56	69	0.151760E 00	56	72	0.605809E-01	56	73	0.893043E-01
56	74	0.109146E 00	56	77	0.706070E-02	56	78	0.438423E-01
56	79	0.746478E-01	56	82	-0.223452E-01	56	83	0.154735E-01
56	84	0.500438E-01	56	87	-0.332876E-01	56	88	0.494500E-03
56	89	0.338149E-01	56	92	-0.317976E-01	56	93	-0.542140E-02
56	94	0.240781E-01	56	97	-0.270588E-01	56	98	-0.729130E-02
56	99	0.182786E-01	56	103	-0.958610E-02	56	104	0.143473E-01
56	107	-0.333954E-01	56	108	-0.142337E-01	56	109	0.111644E-01
56	112	-0.462416E-01	56	113	-0.208290E-01	56	114	0.895220E-02
56	117	-0.595584E-01	56	118	-0.262202E-01	56	119	0.904250E-02
57	2	-0.451940E-01	57	3	0.301250E-02	57	4	0.518504E-01
57	7	-0.395089E-01	57	8	0.118414E-01	57	9	0.620821E-01
57	12	-0.177580E-01	57	13	0.334894E-01	57	14	0.811790E-01
57	17	0.246422E-01	57	18	0.700746E-01	57	19	0.109719E 00
57	23	0.122088E 00	57	24	0.146756E 00	57	27	0.177007E 00
57	28	0.185752E 00	57	29	0.189530E 00	57	32	0.272767E 00
57	33	0.253740E 00	57	34	0.233364E 00	57	37	0.360828E 00
57	38	0.315429E 00	57	39	0.272518E 00	57	42	0.424940E 00
57	43	0.360600E 00	57	44	0.301238E 00	57	47	0.451279E 00
57	48	0.381989E 00	57	49	0.314971E 00	57	52	0.443481E 00
57	53	0.375560E 00	57	54	0.310961E 00	57	57	0.378260E 00
57	58	0.342651E 00	57	59	0.288456E 00	57	63	0.275441E 00
57	64	0.255725E 00	57	67	0.182262E 00	57	68	0.208400E 00
57	69	0.217070E 00	57	72	0.126588E 00	57	73	0.158366E 00
57	74	0.180153E 00	57	77	0.907800E-01	57	78	0.122194E 00
57	79	0.149541E 00	57	82	0.665249E-01	57	83	0.964048E-01
57	84	0.125420E 00	57	87	0.499092E-01	57	88	0.775117E-01
57	89	0.106485E 00	57	92	0.371705E-01	57	93	0.624844E-01
57	94	0.912510E-01	57	97	0.241293E-01	57	98	0.490064E-01
57	99	0.784781E-01	57	103	0.358841E-01	57	104	0.675060E-01
57	107	-0.744330E-02	57	108	0.231368E-01	57	109	0.583545E-01
57	112	-0.244548E-01	57	113	0.118082E-01	57	114	0.517471E-01
57	117	-0.387109E-01	57	118	0.407530E-02	57	119	0.489987E-01

58	2	-0.105842E-01	58	3	0.416340E-01	58	4	0.954760E-01
58	7	-0.525590E-02	58	8	0.494872E-01	58	9	0.104437E 00
58	12	0.132309E-01	58	13	0.685639E-01	58	14	0.121699E 00
58	17	0.494339E-01	58	18	0.100922E 00	58	19	0.147797E 00
58	23	0.147753E 00	58	24	0.181936E 00	58	27	0.186110E 00
58	28	0.205719E 00	58	29	0.221681E 00	58	32	0.273089E 00
58	33	0.267808E 00	58	34	0.262738E 00	58	37	0.350653E 00
58	38	0.323432E 00	58	39	0.300025E 00	58	42	0.402814E 00
58	43	0.363885E 00	58	44	0.328774E 00	58	47	0.420658E 00
58	48	0.382201E 00	58	49	0.346807E 00	58	52	0.399792E 00
58	53	0.391973E 00	58	54	0.350838E 00	58	57	0.348813E 00
58	58	0.358293E 00	58	59	0.343932E 00	58	63	0.311952E 00
58	64	0.309448E 00	58	67	0.209042E 00	58	68	0.248844E 00
58	69	0.274197E 00	58	72	0.178519E 00	58	73	0.214235E 00
58	74	0.241328E 00	58	77	0.158886E 00	58	78	0.187402E 00
58	79	0.214593E 00	58	82	0.140217E 00	58	83	0.165188E 00
58	84	0.191779E 00	58	87	0.119791E 00	58	88	0.144020E 00
58	89	0.171354E 00	58	92	0.962694E-01	58	93	0.122511E 00
58	94	0.152432E 00	58	97	0.699790E-01	58	98	0.100802E 00
58	99	0.134951E 00	58	103	0.806015E-01	58	104	0.119427E 00
58	107	0.231803E-01	58	108	0.634332E-01	58	109	0.106736E 00
58	112	0.634350E-02	58	113	0.505331E-01	58	114	0.978079E-01
58	117	-0.572730E-02	58	118	0.426906E-01	58	119	0.936736E-01
59	2	0.365063E-01	59	3	0.891018E-01	59	4	0.144606E 00
59	7	0.404857E-01	59	8	0.953192E-01	59	9	0.151948E 00
59	12	0.529990E-01	59	13	0.109938E 00	59	14	0.166248E 00
59	17	0.789745E-01	59	18	0.135199E 00	59	19	0.188154E 00
59	23	0.173355E 00	59	24	0.217251E 00	59	27	0.190070E 00
59	28	0.221908E 00	59	29	0.251676E 00	59	32	0.263551E 00
59	33	0.274536E 00	59	34	0.287755E 00	59	37	0.326735E 00
59	38	0.321070E 00	59	39	0.321152E 00	59	42	0.365199E 00
59	43	0.353536E 00	59	44	0.348198E 00	59	47	0.371541E 00
59	48	0.368313E 00	59	49	0.367522E 00	59	52	0.343390E 00
59	53	0.364268E 00	59	54	0.389330E 00	59	57	0.289769E 00
59	58	0.348667E 00	59	59	0.365988E 00	59	63	0.307229E 00
59	64	0.361113E 00	59	67	0.218444E 00	59	68	0.274983E 00
59	69	0.319079E 00	59	72	0.210958E 00	59	73	0.253434E 00
59	74	0.291909E 00	59	77	0.206275E 00	59	78	0.236777E 00
59	79	0.269342E 00	59	82	0.194455E 00	59	83	0.219388E 00
59	84	0.248712E 00	59	87	0.173490E 00	59	88	0.198419E 00
59	89	0.228288E 00	59	92	0.143935E 00	59	93	0.173836E 00
59	94	0.207778E 00	59	97	0.109875E 00	59	98	0.147870E 00
59	99	0.188088E 00	59	103	0.124696E 00	59	104	0.170631E 00
59	107	0.585962E-01	59	108	0.106888E 00	59	109	0.156840E 00
59	112	0.460876E-01	59	113	0.954615E-01	59	114	0.147573E 00
59	117	0.388675E-01	59	118	0.894732E-01	59	119	0.143359E 00
60	2	0.949826E-01	60	3	0.144412E 00	60	4	0.198292E 00
60	7	0.965875E-01	60	8	0.148345E 00	60	9	0.203709E 00
60	12	0.100549E 00	60	13	0.156745E 00	60	14	0.214027E 00
60	17	0.112588E 00	60	18	0.172284E 00	60	19	0.230165E 00
60	23	0.198612E 00	60	24	0.252281E 00	60	27	0.189348E 00
60	28	0.234426E 00	60	29	0.279284E 00	60	32	0.245398E 00
60	33	0.274417E 00	60	34	0.308220E 00	60	37	0.291571E 00
60	38	0.308899E 00	60	39	0.335369E 00	60	42	0.315701E 00
60	43	0.330749E 00	60	44	0.357188E 00	60	47	0.313283E 00
60	48	0.336102E 00	60	49	0.371651E 00	60	52	0.285813E 00
60	53	0.325913E 00	60	54	0.376496E 00	60	57	0.246598E 00

60	58	0.304742E 00	60	59	0.378259E 00	60	63	0.288732E 00
60	64	0.359692E 00	60	67	0.212367E 00	60	68	0.277821E 00
60	69	0.343836E 00	60	72	0.223010E 00	60	73	0.273337E 00
60	74	0.327124E 00	60	77	0.231695E 00	60	78	0.268006E 00
60	79	0.311203E 00	60	82	0.228006E 00	60	83	0.257407E 00
60	84	0.294458E 00	60	87	0.210024E 00	60	88	0.239504E 00
60	89	0.275976E 00	60	92	0.179452E 00	60	93	0.215540E 00
60	94	0.256226E 00	60	97	0.143292E 00	60	98	0.189460E 00
60	99	0.236961E 00	60	103	0.167475E 00	60	104	0.220244E 00
60	107	0.982549E-01	60	108	0.152774E 00	60	109	0.207792E 00
60	112	0.940483E-01	60	113	0.145771E 00	60	114	0.200136E 00
60	117	0.941342E-01	60	118	0.143492E 00	60	119	0.197117E 00
61	2	-0.598425E-01	61	3	-0.251024E-01	61	4	0.962810E-02
61	7	-0.545711E-01	61	8	-0.210249E-01	61	9	0.125121E-01
61	12	-0.391660E-01	61	13	-0.910760E-02	61	14	0.209751E-01
61	17	-0.146377E-01	61	18	0.989300E-02	61	19	0.344190E-01
61	23	0.346230E-01	61	24	0.519307E-01	61	27	0.545119E-01
61	28	0.634134E-01	61	29	0.723141E-01	61	32	0.943842E-01
61	33	0.942820E-01	61	34	0.941850E-01	61	37	0.134224E 00
61	38	0.125122E 00	61	39	0.116033E 00	61	42	0.171331E 00
61	43	0.153822E 00	61	44	0.136354E 00	61	47	0.203057E 00
61	48	0.178399E 00	61	49	0.153775E 00	61	52	0.227411E 00
61	53	0.197157E 00	61	54	0.167102E 00	61	57	0.241925E 00
61	58	0.208954E 00	61	59	0.175446E 00	61	63	0.212602E 00
61	64	0.178374E 00	61	67	0.241911E 00	61	68	0.208952E 00
61	69	0.175458E 00	61	72	0.227413E 00	61	73	0.197154E 00
61	74	0.167109E 00	61	77	0.203076E 00	61	78	0.178407E 00
61	79	0.153771E 00	61	82	0.171335E 00	61	83	0.153826E 00
61	84	0.136357E 00	61	87	0.134245E 00	61	88	0.125129E 00
61	89	0.116026E 00	61	92	0.943882E-01	61	93	0.942911E-01
61	94	0.941834E-01	61	97	0.544984E-01	61	98	0.634114E-01
61	99	0.723236E-01	61	103	0.346095E-01	61	104	0.519382E-01
61	107	-0.146377E-01	61	108	0.989120E-02	61	109	0.344154E-01
61	112	-0.391666E-01	61	113	-0.909710E-02	61	114	0.209654E-01
61	117	-0.545722E-01	61	118	-0.210277E-01	61	119	0.125077E-01
62	2	-0.374654E-01	62	3	0.521370E-02	62	4	0.485882E-01
62	7	-0.322344E-01	62	8	0.949260E-02	62	9	0.518052E-01
62	12	-0.167860E-01	62	13	0.221792E-01	62	14	0.613251E-01
62	17	0.880350E-02	62	18	0.429443E-01	62	19	0.766715E-01
62	23	0.711218E-01	62	24	0.969093E-01	62	27	0.887150E-01
62	28	0.104705E 00	62	29	0.120588E 00	62	32	0.136370E 00
62	33	0.140596E 00	62	34	0.145730E 00	62	37	0.180977E 00
62	38	0.174753E 00	62	39	0.170175E 00	62	42	0.217201E 00
62	43	0.203858E 00	62	44	0.191946E 00	62	47	0.241914E 00
62	48	0.225927E 00	62	49	0.209854E 00	62	52	0.253926E 00
62	53	0.241257E 00	62	54	0.223211E 00	62	57	0.260758E 00
62	58	0.251251E 00	62	59	0.231586E 00	62	63	0.256270E 00
62	64	0.234228E 00	62	67	0.260800E 00	62	68	0.251275E 00
62	69	0.231606E 00	62	72	0.253999E 00	62	73	0.241298E 00
62	74	0.223236E 00	62	77	0.242000E 00	62	78	0.225981E 00
62	79	0.209876E 00	62	82	0.217205E 00	62	83	0.203861E 00
62	84	0.191948E 00	62	87	0.180962E 00	62	88	0.174729E 00
62	89	0.170141E 00	62	92	0.136345E 00	62	93	0.140578E 00
62	94	0.145706E 00	62	97	0.886756E-01	62	98	0.104681E 00
62	99	0.120581E 00	62	103	0.710917E-01	62	104	0.969018E-01
62	107	0.880150E-02	62	108	0.429326E-01	62	109	0.766526E-01
62	112	-0.167890E-01	62	113	0.221851E-01	62	114	0.613017E-01

62 117	-0.322390E-01	62 118	0.948260E-02	62 119	0.517901E-01
63 2	-0.726960E-02	63 3	0.427588E-01	63 4	0.945035E-01
63 7	-0.257990E-02	63 8	0.469046E-01	63 9	0.978720E-01
63 12	0.114825E-01	63 13	0.594209E-01	63 14	0.107941E 00
63 17	0.360575E-01	63 18	0.805731E-01	63 19	0.124461E 00
63 23	0.110644E 00	63 24	0.146635E 00	63 27	0.122167E 00
63 28	0.147589E 00	63 29	0.172956E 00	63 32	0.175845E 00
63 33	0.187496E 00	63 34	0.201062E 00	63 37	0.224254E 00
63 38	0.224657E 00	63 39	0.228343E 00	63 42	0.259899E 00
63 43	0.254742E 00	63 44	0.252587E 00	63 47	0.279037E 00
63 48	0.276074E 00	63 49	0.272988E 00	63 52	0.281187E 00
63 53	0.289086E 00	63 54	0.290690E 00	63 57	0.277424E 00
63 58	0.311330E 00	63 59	0.304690E 00	63 63	0.314937E 00
63 64	0.315847E 00	63 67	0.277507E 00	63 68	0.311375E 00
63 69	0.304720E 00	63 72	0.281290E 00	63 73	0.289160E 00
63 74	0.290728E 00	63 77	0.279157E 00	63 78	0.276154E 00
63 79	0.273026E 00	63 82	0.259902E 00	63 83	0.254744E 00
63 84	0.252589E 00	63 87	0.224232E 00	63 88	0.224625E 00
63 89	0.228299E 00	63 92	0.175810E 00	63 93	0.187467E 00
63 94	0.201029E 00	63 97	0.122111E 00	63 98	0.147555E 00
63 99	0.172941E 00	63 103	0.110601E 00	63 104	0.146616E 00
63 107	0.360496E-01	63 108	0.805501E-01	63 109	0.124427E 00
63 112	0.114670E-01	63 113	0.594163E-01	63 114	0.107902E 00
63 117	-0.260120E-02	63 118	0.468795E-01	63 119	0.978431E-01
64 2	0.366647E-01	64 3	0.885597E-01	64 4	0.143395E 00
64 7	0.397194E-01	64 8	0.917611E-01	64 9	0.146377E 00
64 12	0.492209E-01	64 13	0.101759E 00	64 14	0.155432E 00
64 17	0.678555E-01	64 18	0.119631E 00	64 19	0.170691E 00
64 23	0.146967E 00	64 24	0.191722E 00	64 27	0.147123E 00
64 28	0.182109E 00	64 29	0.217242E 00	64 32	0.199898E 00
64 33	0.220785E 00	64 34	0.244797E 00	64 37	0.245800E 00
64 38	0.256023E 00	64 39	0.271577E 00	64 42	0.275943E 00
64 43	0.282916E 00	64 44	0.295275E 00	64 47	0.286427E 00
64 48	0.299308E 00	64 49	0.315346E 00	64 52	0.277355E 00
64 53	0.307813E 00	64 54	0.333311E 00	64 57	0.257599E 00
64 58	0.311657E 00	64 59	0.361238E 00	64 63	0.321303E 00
64 64	0.350337E 00	64 67	0.257640E 00	64 68	0.311662E 00
64 69	0.361229E 00	64 72	0.277373E 00	64 73	0.307828E 00
64 74	0.333297E 00	64 77	0.286443E 00	64 78	0.299312E 00
64 79	0.315332E 00	64 82	0.275945E 00	64 83	0.282918E 00
64 84	0.295276E 00	64 87	0.245831E 00	64 88	0.256043E 00
64 89	0.271583E 00	64 92	0.199908E 00	64 93	0.220799E 00
64 94	0.244814E 00	64 97	0.147098E 00	64 98	0.182113E 00
64 99	0.217273E 00	64 103	0.146960E 00	64 104	0.191741E 00
64 107	0.678785E-01	64 108	0.119640E 00	64 109	0.170690E 00
64 112	0.492323E-01	64 113	0.101786E 00	64 114	0.155425E 00
64 117	0.397248E-01	64 118	0.917650E-01	64 119	0.146380E 00
65 2	0.930732E-01	65 3	0.142606E 00	65 4	0.196556E 00
65 7	0.935259E-01	65 8	0.144160E 00	65 9	0.198702E 00
65 12	0.956681E-01	65 13	0.149615E 00	65 14	0.205441E 00
65 17	0.104067E 00	65 18	0.161070E 00	65 19	0.217429E 00
65 23	0.181768E 00	65 24	0.234814E 00	65 27	0.165437E 00
65 28	0.210843E 00	65 29	0.256795E 00	65 32	0.211719E 00
65 33	0.244094E 00	65 34	0.281066E 00	65 37	0.250437E 00
65 38	0.273653E 00	65 39	0.304757E 00	65 42	0.272071E 00
65 43	0.294056E 00	65 44	0.325260E 00	65 47	0.273463E 00
65 48	0.302908E 00	65 49	0.341497E 00	65 52	0.256066E 00

65	53	0.301503E 00	65	54	0.353809E 00	65	57	0.231345E 00
65	58	0.294577E 00	65	59	0.361575E 00	65	63	0.289838E 00
65	64	0.370586E 00	65	67	0.231416E 00	65	68	0.294606E 00
65	69	0.361578E 00	65	72	0.256132E 00	65	73	0.301560E 00
65	74	0.353827E 00	65	77	0.273533E 00	65	78	0.302960E 00
65	79	0.341526E 00	65	82	0.272073E 00	65	83	0.294057E 00
65	84	0.325260E 00	65	87	0.250422E 00	65	88	0.273632E 00
65	89	0.304725E 00	65	92	0.211690E 00	65	93	0.244064E 00
65	94	0.281049E 00	65	97	0.165379E 00	65	98	0.210815E 00
65	99	0.256794E 00	65	103	0.181738E 00	65	104	0.234803E 00
65	107	0.104081E 00	65	108	0.161058E 00	65	109	0.217399E 00
65	112	0.956659E-01	65	113	0.149622E 00	65	114	0.205410E 00
65	117	0.935161E-01	65	118	0.144146E 00	65	119	0.198684E 00
66	2	-0.663334E-01	66	3	-0.263384E-01	66	4	0.135805E-01
66	7	-0.595526E-01	66	8	-0.262136E-01	66	9	0.905100E-02
66	12	-0.462406E-01	66	13	-0.208481E-01	66	14	0.895140E-02
66	17	-0.334295E-01	66	18	-0.142678E-01	66	19	0.111426E-01
66	23	-0.965400E-02	66	24	0.142910E-01	66	27	-0.271870E-01
66	28	-0.740620E-02	66	29	0.181854E-01	66	32	-0.320189E-01
66	33	-0.558140E-02	66	34	0.239599E-01	66	37	-0.335858E-01
66	38	0.279200E-03	66	39	0.336859E-01	66	42	-0.223499E-01
66	43	0.154700E-01	66	44	0.500414E-01	66	47	0.738500E-02
66	48	0.441374E-01	66	49	0.749212E-01	66	52	0.608566E-01
66	53	0.895500E-01	66	54	0.109394E 00	66	57	0.141772E 00
66	58	0.152819E 00	66	59	0.151946E 00	66	63	0.229167E 00
66	64	0.197442E 00	66	67	0.378327E 00	66	68	0.300837E 00
66	69	0.237993E 00	66	72	0.443063E 00	66	73	0.348599E 00
66	74	0.265284E 00	66	77	0.454504E 00	66	78	0.360305E 00
66	79	0.274132E 00	66	82	0.419894E 00	66	83	0.339298E 00
66	84	0.263286E 00	66	87	0.350123E 00	66	88	0.292250E 00
66	89	0.235809E 00	66	92	0.258040E 00	66	93	0.228955E 00
66	94	0.197063E 00	66	97	0.160527E 00	66	98	0.159930E 00
66	99	0.153340E 00	66	103	0.954252E-01	66	104	0.110513E 00
66	107	0.528580E-02	66	108	0.425909E-01	66	109	0.732490E-01
66	112	-0.386983E-01	66	113	0.513640E-02	66	114	0.443315E-01
66	117	-0.609852E-01	66	118	-0.171133E-01	66	119	0.246545E-01
67	2	-0.451934E-01	67	3	0.301290E-02	67	4	0.518505E-01
67	7	-0.386755E-01	67	8	0.410110E-02	67	9	0.490126E-01
67	12	-0.244278E-01	67	13	0.118137E-01	67	14	0.517688E-01
67	17	-0.743640E-02	67	18	0.231507E-01	67	19	0.583729E-01
67	23	0.359030E-01	67	24	0.675105E-01	67	27	0.241612E-01
67	28	0.490215E-01	67	29	0.784737E-01	67	32	0.371847E-01
67	33	0.625031E-01	67	34	0.912540E-01	67	37	0.499200E-01
67	38	0.775227E-01	67	39	0.106499E 00	67	42	0.665210E-01
67	43	0.964018E-01	67	44	0.125418E 00	67	47	0.907240E-01
67	48	0.122181E 00	67	49	0.149570E 00	67	52	0.126543E 00
67	53	0.158348E 00	67	54	0.180189E 00	67	57	0.182262E 00
67	58	0.208423E 00	67	59	0.217100E 00	67	63	0.275521E 00
67	64	0.255762E 00	67	67	0.378330E 00	67	68	0.342732E 00
67	69	0.288528E 00	67	72	0.443568E 00	67	73	0.375621E 00
67	74	0.311050E 00	67	77	0.451387E 00	67	78	0.382078E 00
67	79	0.315043E 00	67	82	0.424943E 00	67	83	0.360603E 00
67	84	0.301240E 00	67	87	0.360878E 00	67	88	0.315444E 00
67	89	0.272499E 00	67	92	0.272777E 00	67	93	0.253763E 00
67	94	0.233346E 00	67	97	0.176979E 00	67	98	0.185741E 00
67	99	0.189531E 00	67	103	0.122047E 00	67	104	0.146755E 00
67	107	0.246275E-01	67	108	0.700548E-01	67	109	0.109696E 00

67 112	-0.177704E-01	67 113	0.334888E-01	67 114	0.811409E-01
67 117	-0.395266E-01	67 118	0.118177E-01	67 119	0.620493E-01
68 2	-0.105837E-01	68 3	0.416343E-01	68 4	0.954762E-01
68 7	-0.570270E-02	68 8	0.427103E-01	68 9	0.936868E-01
68 12	0.635950E-02	68 13	0.505297E-01	68 14	0.978290E-01
68 17	0.231758E-01	68 18	0.634401E-01	68 19	0.106752E 00
68 23	0.806147E-01	68 24	0.119425E 00	68 27	0.700026E-01
68 28	0.100806E 00	68 29	0.134936E 00	68 32	0.962633E-01
68 33	0.122512E 00	68 34	0.152425E 00	68 37	0.119770E 00
68 38	0.144010E 00	68 39	0.171357E 00	68 42	0.140214E 00
68 43	0.165186E 00	68 44	0.191778E 00	68 47	0.158833E 00
68 48	0.187378E 00	68 49	0.214600E 00	68 52	0.178473E 00
68 53	0.214203E 00	68 54	0.241339E 00	68 57	0.209018E 00
68 58	0.248843E 00	68 59	0.274200E 00	68 63	0.311997E 00
68 64	0.309451E 00	68 67	0.348897E 00	68 68	0.358320E 00
68 69	0.343961E 00	68 72	0.399847E 00	68 73	0.392009E 00
68 74	0.350878E 00	68 77	0.420724E 00	68 78	0.382249E 00
68 79	0.346834E 00	68 82	0.402816E 00	68 83	0.363887E 00
68 84	0.328776E 00	68 87	0.350666E 00	68 88	0.323427E 00
68 89	0.300001E 00	68 92	0.273075E 00	68 93	0.267812E 00
68 94	0.262722E 00	68 97	0.186066E 00	68 98	0.205702E 00
68 99	0.221687E 00	68 103	0.147718E 00	68 104	0.181941E 00
68 107	0.494348E-01	68 108	0.100913E 00	68 109	0.147781E 00
68 112	0.132339E-01	68 113	0.685785E-01	68 114	0.121674E 00
68 117	-0.525660E-02	68 118	0.494797E-01	68 119	0.104421E 00
69 2	0.365067E-01	69 3	0.891021E-01	69 4	0.144606E 00
69 7	0.388814E-01	69 8	0.894850E-01	69 9	0.143368E 00
69 12	0.460920E-01	69 13	0.954483E-01	69 14	0.147589E 00
69 17	0.585777E-01	69 18	0.106885E 00	69 19	0.156850E 00
69 23	0.124697E 00	69 24	0.170617E 00	69 27	0.109886E 00
69 28	0.147859E 00	69 29	0.188056E 00	69 32	0.143905E 00
69 33	0.173816E 00	69 34	0.207753E 00	69 37	0.173436E 00
69 38	0.198382E 00	69 39	0.228271E 00	69 42	0.194453E 00
69 43	0.219386E 00	69 44	0.248711E 00	69 47	0.206238E 00
69 48	0.236755E 00	69 49	0.269340E 00	69 52	0.210926E 00
69 53	0.253402E 00	69 54	0.291912E 00	69 57	0.218413E 00
69 58	0.274979E 00	69 59	0.319078E 00	69 63	0.307259E 00
69 64	0.361104E 00	69 67	0.289843E 00	69 68	0.348697E 00
69 69	0.365982E 00	69 72	0.343436E 00	69 73	0.364297E 00
69 74	0.389327E 00	69 77	0.371582E 00	69 78	0.368335E 00
69 79	0.367513E 00	69 82	0.365201E 00	69 83	0.353537E 00
69 84	0.348199E 00	69 87	0.326710E 00	69 88	0.321045E 00
69 89	0.321125E 00	69 92	0.263514E 00	69 93	0.274519E 00
69 94	0.287741E 00	69 97	0.190012E 00	69 98	0.221886E 00
69 99	0.251687E 00	69 103	0.173327E 00	69 104	0.217261E 00
69 107	0.789934E-01	69 108	0.135202E 00	69 109	0.188148E 00
69 112	0.530193E-01	69 113	0.109969E 00	69 114	0.166239E 00
69 117	0.405042E-01	69 118	0.953302E-01	69 119	0.151951E 00
70 2	0.949829E-01	70 3	0.144412E 00	70 4	0.198292E 00
70 7	0.941360E-01	70 8	0.143495E 00	70 9	0.197121E 00
70 12	0.940419E-01	70 13	0.145753E 00	70 14	0.200151E 00
70 17	0.982293E-01	70 18	0.152771E 00	70 19	0.207806E 00
70 23	0.167484E 00	70 24	0.220238E 00	70 27	0.143328E 00
70 28	0.189466E 00	70 29	0.236941E 00	70 32	0.179455E 00
70 33	0.215548E 00	70 34	0.256219E 00	70 37	0.210012E 00
70 38	0.239499E 00	70 39	0.275982E 00	70 42	0.228005E 00
70 43	0.257406E 00	70 44	0.294457E 00	70 47	0.231665E 00

70	48	0.267988E 00	70	49	0.311202E 00	70	52	0.222976E 00
70	53	0.273304E 00	70	54	0.327132E 00	70	57	0.212319E 00
70	58	0.277810E 00	70	59	0.343848E 00	70	63	0.288741E 00
70	64	0.359690E 00	70	67	0.246658E 00	70	68	0.304759E 00
70	69	0.378247E 00	70	72	0.285849E 00	70	73	0.325944E 00
70	74	0.376495E 00	70	77	0.313313E 00	70	78	0.336122E 00
70	79	0.371656E 00	70	82	0.315702E 00	70	83	0.330750E 00
70	84	0.357189E 00	70	87	0.291568E 00	70	88	0.308892E 00
70	89	0.335354E 00	70	92	0.245380E 00	70	93	0.274404E 00
70	94	0.308219E 00	70	97	0.189299E 00	70	98	0.234413E 00
70	99	0.279302E 00	70	103	0.198594E 00	70	104	0.252289E 00
70	107	0.112616E 00	70	108	0.172289E 00	70	109	0.230153E 00
70	112	0.100566E 00	70	113	0.156771E 00	70	114	0.214014E 00
70	117	0.965995E-01	70	118	0.148350E 00	70	119	0.203707E 00
71	2	-0.108347E 00	71	3	-0.472430E-01	71	4	0.130105E-01
71	7	-0.964544E-01	71	8	-0.480007E-01	71	9	0.353020E-02
71	12	-0.753106E-01	71	13	-0.413887E-01	71	14	0.467300E-03
71	17	-0.585661E-01	71	18	-0.351818E-01	71	19	-0.280300E-03
71	23	-0.353013E-01	71	24	-0.127030E-02	71	27	-0.712199E-01
71	28	-0.425881E-01	71	29	-0.290030E-02	71	32	-0.973657E-01
71	33	-0.534417E-01	71	34	-0.299590E-02	71	37	-0.121182E 00
71	38	-0.595482E-01	71	39	0.253740E-02	71	42	-0.125503E 00
71	43	-0.510489E-01	71	44	0.189507E-01	71	47	-0.979083E-01
71	48	-0.187073E-01	71	49	0.510411E-01	71	52	-0.283259E-01
71	53	0.446539E-01	71	54	0.101987E 00	71	57	0.930243E-01
71	58	0.142915E 00	71	59	0.171364E 00	71	63	0.274506E 00
71	64	0.252467E 00	71	67	0.502406E 00	71	68	0.415685E 00
71	69	0.332829E 00	71	72	0.699222E 00	71	73	0.530485E 00
71	74	0.396556E 00	71	77	0.776076E 00	71	78	0.588215E 00
71	79	0.429994E 00	71	82	0.739371E 00	71	83	0.575893E 00
71	84	0.427244E 00	71	87	0.626759E 00	71	88	0.506257E 00
71	89	0.390787E 00	71	92	0.466783E 00	71	93	0.400676E 00
71	94	0.329824E 00	71	97	0.292862E 00	71	98	0.280768E 00
71	99	0.256741E 00	71	103	0.167029E 00	71	104	0.183198E 00
71	107	0.151178E-01	71	108	0.736150E-01	71	109	0.118432E 00
71	112	-0.619826E-01	71	113	0.782240E-02	71	114	0.678884E-01
71	117	-0.999514E-01	71	118	-0.309340E-01	71	119	0.332665E-01
72	2	-0.658920E-01	72	3	-0.641960E-02	72	4	0.532008E-01
72	7	-0.572425E-01	72	8	-0.742480E-02	72	9	0.454715E-01
72	12	-0.402861E-01	72	13	-0.132380E-02	72	14	0.440599E-01
72	17	-0.246939E-01	72	18	0.627340E-02	72	19	0.458903E-01
72	23	0.113546E-01	72	24	0.489403E-01	72	27	-0.182650E-01
72	28	0.129407E-01	72	29	0.526258E-01	72	32	-0.267030E-01
72	33	0.127599E-01	72	34	0.580165E-01	72	37	-0.349178E-01
72	38	0.154194E-01	72	39	0.675424E-01	72	42	-0.320239E-01
72	43	0.272220E-01	72	44	0.846207E-01	72	47	-0.952020E-02
72	48	0.546271E-01	72	49	0.112683E 00	72	52	0.403331E-01
72	53	0.103605E 00	72	54	0.154443E 00	72	57	0.127549E 00
72	58	0.178467E 00	72	59	0.210392E 00	72	63	0.281231E 00
72	64	0.276267E 00	72	67	0.444121E 00	72	68	0.397952E 00
72	69	0.341872E 00	72	72	0.606057E 00	72	73	0.500467E 00
72	74	0.391878E 00	72	77	0.670769E 00	72	78	0.537856E 00
72	79	0.418766E 00	72	82	0.639498E 00	72	83	0.523257E 00
72	84	0.413275E 00	72	87	0.553090E 00	72	88	0.464006E 00
72	89	0.379819E 00	72	92	0.420368E 00	72	93	0.374985E 00
72	94	0.326418E 00	72	97	0.273039E 00	72	98	0.272849E 00
72	99	0.263150E 00	72	103	0.175878E 00	72	104	0.199671E 00

72 107	0.379661E-01	72 108	0.964643E-01	72 109	0.143870E 00
72 112	-0.260835E-01	72 113	0.408285E-01	72 114	0.100353E 00
72 117	-0.579366E-01	72 118	0.783380E-02	72 119	0.705546E-01
73 2	-0.185780E-01	73 3	0.390723E-01	73 4	0.980774E-01
73 7	-0.132603E-01	73 8	0.376430E-01	73 9	0.918603E-01
73 12	-0.127450E-02	73 13	0.426010E-01	73 14	0.916197E-01
73 17	0.117293E-01	73 18	0.505292E-01	73 19	0.953287E-01
73 23	0.594553E-01	73 24	0.101572E 00	73 27	0.332767E-01
73 28	0.684375E-01	73 29	0.109695E 00	73 32	0.404909E-01
73 33	0.775371E-01	73 34	0.119803E 00	73 37	0.461070E-01
73 38	0.878649E-01	73 39	0.132816E 00	73 42	0.551034E-01
73 43	0.102393E 00	73 44	0.150465E 00	73 47	0.724450E-01
73 48	0.125068E 00	73 49	0.174965E 00	73 52	0.103730E 00
73 53	0.160713E 00	73 54	0.208678E 00	73 57	0.159181E 00
73 58	0.214374E 00	73 59	0.253026E 00	73 63	0.289551E 00
73 64	0.306989E 00	73 67	0.377718E 00	73 68	0.392002E 00
73 69	0.362258E 00	73 72	0.506545E 00	73 73	0.464726E 00
73 74	0.409866E 00	73 77	0.557446E 00	73 78	0.500766E 00
73 79	0.419839E 00	73 82	0.546657E 00	73 83	0.474156E 00
73 84	0.408295E 00	73 87	0.480807E 00	73 88	0.426220E 00
73 89	0.375286E 00	73 92	0.375281E 00	73 93	0.352464E 00
73 94	0.328404E 00	73 97	0.254218E 00	73 98	0.267813E 00
73 99	0.274311E 00	73 103	0.187709E 00	73 104	0.220648E 00
73 107	0.631872E-01	73 108	0.122735E 00	73 109	0.173814E 00
73 112	0.132419E-01	73 113	0.778153E-01	73 114	0.137440E 00
73 117	-0.115493E-01	73 118	0.510665E-01	73 119	0.112566E 00
74 2	0.372432E-01	74 3	0.914350E-01	74 4	0.148459E 00
74 7	0.388270E-01	74 8	0.891674E-01	74 9	0.143342E 00
74 12	0.442002E-01	74 13	0.917117E-01	74 14	0.143354E 00
74 17	0.518817E-01	74 18	0.979412E-01	74 19	0.147585E 00
74 23	0.108157E 00	74 24	0.155366E 00	74 27	0.812476E-01
74 28	0.121747E 00	74 29	0.166161E 00	74 32	0.100335E 00
74 33	0.137431E 00	74 34	0.179331E 00	74 37	0.116486E 00
74 38	0.153144E 00	74 39	0.194503E 00	74 42	0.129357E 00
74 43	0.168841E 00	74 44	0.211879E 00	74 47	0.140883E 00
74 48	0.186207E 00	74 49	0.232601E 00	74 52	0.154822E 00
74 53	0.208932E 00	74 54	0.258561E 00	74 57	0.181157E 00
74 58	0.241853E 00	74 59	0.291948E 00	74 63	0.291961E 00
74 64	0.333223E 00	74 67	0.312971E 00	74 68	0.352944E 00
74 69	0.389353E 00	74 72	0.392893E 00	74 73	0.414622E 00
74 74	0.403504E 00	74 77	0.445932E 00	74 78	0.431520E 00
74 79	0.428936E 00	74 82	0.448496E 00	74 83	0.422340E 00
74 84	0.401482E 00	74 87	0.405176E 00	74 88	0.385241E 00
74 89	0.371354E 00	74 92	0.326976E 00	74 93	0.328740E 00
74 94	0.331817E 00	74 97	0.234001E 00	74 98	0.262995E 00
74 99	0.287777E 00	74 103	0.201500E 00	74 104	0.244828E 00
74 107	0.919141E-01	74 108	0.152745E 00	74 109	0.207873E 00
74 112	0.584811E-01	74 113	0.120127E 00	74 114	0.179431E 00
74 117	0.425552E-01	74 118	0.100745E 00	74 119	0.159988E 00
75 2	0.100963E 00	75 3	0.149950E 00	75 4	0.203496E 00
75 7	0.985525E-01	75 8	0.146490E 00	75 9	0.199069E 00
75 12	0.957704E-01	75 13	0.145375E 00	75 14	0.198394E 00
75 17	0.953687E-01	75 18	0.147821E 00	75 19	0.201728E 00
75 23	0.156602E 00	75 24	0.209269E 00	75 27	0.124640E 00
75 28	0.171720E 00	75 29	0.220793E 00	75 32	0.151258E 00
75 33	0.190903E 00	75 34	0.235140E 00	75 37	0.174013E 00
75 38	0.209282E 00	75 39	0.250884E 00	75 42	0.187992E 00

75	43	0.224205E 00	75	44	0.266925E 00	75	47	0.192685E 00
75	48	0.235329E 00	75	49	0.283300E 00	75	52	0.190635E 00
75	53	0.245152E 00	75	54	0.301238E 00	75	57	0.191673E 00
75	58	0.258219E 00	75	59	0.322511E 00	75	63	0.280875E 00
75	64	0.347453E 00	75	67	0.254964E 00	75	68	0.311364E 00
75	69	0.372121E 00	75	72	0.308350E 00	75	73	0.341215E 00
75	74	0.396512E 00	75	77	0.345493E 00	75	78	0.362457E 00
75	79	0.395770E 00	75	82	0.353090E 00	75	83	0.362543E 00
75	84	0.386803E 00	75	87	0.328468E 00	75	88	0.341286E 00
75	89	0.365044E 00	75	92	0.276841E 00	75	93	0.303516E 00
75	94	0.335509E 00	75	97	0.212759E 00	75	98	0.258183E 00
75	99	0.302818E 00	75	103	0.216826E 00	75	104	0.271559E 00
75	107	0.123584E 00	75	108	0.185890E 00	75	109	0.245344E 00
75	112	0.108908E 00	75	113	0.167045E 00	75	114	0.225556E 00
75	117	0.103657E 00	75	118	0.156124E 00	75	119	0.212007E 00
76	2	-0.150680E 00	76	3	-0.699686E-01	76	4	0.869670E-02
76	7	-0.134937E 00	76	8	-0.712606E-01	76	9	-0.428750E-02
76	12	-0.105279E 00	76	13	-0.617041E-01	76	14	-0.820730E-02
76	17	-0.804936E-01	76	18	-0.520241E-01	76	19	-0.877100E-02
76	23	-0.505878E-01	76	24	-0.977960E-02	76	27	-0.918600E-01
76	28	-0.593198E-01	76	29	-0.122791E-01	76	32	-0.125764E 00
76	33	-0.743832E-01	76	34	-0.139781E-01	76	37	-0.159876E 00
76	38	-0.857729E-01	76	39	-0.999240E-02	76	42	-0.172734E 00
76	43	-0.810313E-01	76	44	0.640120E-02	76	47	-0.149099E 00
76	48	-0.488439E-01	76	49	0.410894E-01	76	52	-0.757179E-01
76	53	0.204523E-01	76	54	0.988082E-01	76	57	0.600398E-01
76	58	0.132424E 00	76	59	0.180230E 00	76	63	0.286255E 00
76	64	0.279594E 00	76	67	0.528997E 00	76	68	0.462911E 00
76	69	0.383822E 00	76	72	0.797271E 00	76	73	0.626538E 00
76	74	0.473704E 00	76	77	0.980060E 00	76	78	0.729593E 00
76	79	0.530701E 00	76	82	0.986329E 00	76	83	0.746353E 00
76	84	0.541423E 00	76	87	0.856604E 00	76	88	0.674260E 00
76	89	0.505730E 00	76	92	0.646259E 00	76	93	0.541586E 00
76	94	0.432641E 00	76	97	0.409749E 00	76	98	0.382260E 00
76	99	0.338710E 00	76	103	0.227592E 00	76	104	0.241015E 00
76	107	0.248453E-01	76	108	0.989510E-01	76	109	0.153443E 00
76	112	-0.831372E-01	76	113	0.768230E-02	76	114	0.843709E-01
76	117	-0.137420E 00	76	118	-0.466140E-01	76	119	0.367546E-01
77	2	-0.888010E-01	77	3	-0.173333E-01	77	4	0.535118E-01
77	7	-0.784844E-01	77	8	-0.198385E-01	77	9	0.421851E-01
77	12	-0.574772E-01	77	13	-0.134465E-01	77	14	0.386293E-01
77	17	-0.391323E-01	77	18	-0.585280E-02	77	19	0.386547E-01
77	23	-0.270680E-02	77	24	0.394591E-01	77	27	-0.400555E-01
77	28	-0.549080E-02	77	29	0.401758E-01	77	32	-0.584641E-01
77	33	-0.119205E-01	77	34	0.422019E-01	77	37	-0.776870E-01
77	38	-0.156970E-01	77	39	0.487916E-01	77	42	-0.831897E-01
77	43	-0.835640E-02	77	44	0.645460E-01	77	47	-0.636967E-01
77	48	0.185569E-01	77	49	0.939881E-01	77	52	-0.912820E-02
77	53	0.726461E-01	77	54	0.140821E 00	77	57	0.920613E-01
77	58	0.159136E 00	77	59	0.206073E 00	77	63	0.279310E 00
77	64	0.285919E 00	77	67	0.452020E 00	77	68	0.420224E 00
77	69	0.370697E 00	77	72	0.671240E 00	77	73	0.555945E 00
77	74	0.444500E 00	77	77	0.818548E 00	77	78	0.648959E 00
77	79	0.489338E 00	77	82	0.825500E 00	77	83	0.652828E 00
77	84	0.498269E 00	77	87	0.718337E 00	77	88	0.589872E 00
77	89	0.466590E 00	77	92	0.553435E 00	77	93	0.480637E 00
77	94	0.404612E 00	77	97	0.361402E 00	77	98	0.350510E 00

77	99	0.326382E 00	77	103	0.224406E 00	77	104	0.245623E 00
77	107	0.509418E-01	77	108	0.120054E 00	77	109	0.173464E 00
77	112	-0.342952E-01	77	113	0.464740E-01	77	114	0.116535E 00
77	117	-0.772728E-01	77	118	0.236500E-02	77	119	0.770743E-01
78	2	-0.248785E-01	78	3	0.382363E-01	78	4	0.102317E 00
78	7	-0.197576E-01	78	8	0.345262E-01	78	9	0.924753E-01
78	12	-0.749800E-02	78	13	0.375792E-01	78	14	0.890559E-01
78	17	0.390030E-02	78	18	0.426792E-01	78	19	0.893593E-01
78	23	0.469359E-01	78	24	0.915927E-01	78	27	0.115718E-01
78	28	0.493837E-01	78	29	0.951167E-01	78	32	0.753990E-02
78	33	0.508601E-01	78	34	0.100507E 00	78	37	0.212020E-02
78	38	0.540775E-01	78	39	0.109483E 00	78	42	0.336770E-02
78	43	0.638097E-01	78	44	0.124738E 00	78	47	0.185531E-01
78	48	0.855864E-01	78	49	0.149334E 00	78	52	0.549505E-01
78	53	0.125232E 00	78	54	0.186142E 00	78	57	0.123191E 00
78	58	0.187674E 00	78	59	0.236634E 00	78	63	0.276597E 00
78	64	0.298906E 00	78	67	0.383155E 00	78	68	0.382290E 00
78	69	0.367663E 00	78	72	0.539794E 00	78	73	0.500878E 00
78	74	0.429542E 00	78	77	0.654865E 00	78	78	0.565877E 00
78	79	0.473459E 00	78	82	0.660106E 00	78	83	0.575497E 00
78	84	0.469825E 00	78	87	0.590324E 00	78	88	0.511678E 00
78	89	0.438625E 00	78	92	0.464556E 00	78	93	0.426317E 00
78	94	0.384841E 00	78	97	0.316097E 00	78	98	0.323480E 00
78	99	0.320838E 00	78	103	0.224964E 00	78	104	0.255903E 00
78	107	0.784070E-01	78	108	0.144314E 00	78	109	0.198429E 00
78	112	0.159738E-01	78	113	0.882085E-01	78	114	0.153196E 00
78	117	-0.153207E-01	78	118	0.543078E-01	78	119	0.121635E 00
79	2	0.421629E-01	79	3	0.974876E-01	79	4	0.155579E 00
79	7	0.423461E-01	79	8	0.925683E-01	79	9	0.147000E 00
79	12	0.455588E-01	79	13	0.919307E-01	79	14	0.143340E 00
79	17	0.490682E-01	79	18	0.937917E-01	79	19	0.143368E 00
79	23	0.980912E-01	79	24	0.146330E 00	79	27	0.621132E-01
79	28	0.104501E 00	79	29	0.151892E 00	79	32	0.705332E-01
79	33	0.112572E 00	79	34	0.159916E 00	79	37	0.770581E-01
79	38	0.121613E 00	79	39	0.170726E 00	79	42	0.836895E-01
79	43	0.132953E 00	79	44	0.185246E 00	79	47	0.940850E-01
79	48	0.149433E 00	79	49	0.205193E 00	79	52	0.113062E 00
79	53	0.175221E 00	79	54	0.232660E 00	79	57	0.150462E 00
79	58	0.215034E 00	79	59	0.269422E 00	79	63	0.273891E 00
79	64	0.315312E 00	79	67	0.316494E 00	79	68	0.347651E 00
79	69	0.367563E 00	79	72	0.420437E 00	79	73	0.421931E 00
79	74	0.428957E 00	79	77	0.490159E 00	79	78	0.478147E 00
79	79	0.440861E 00	79	82	0.508787E 00	79	83	0.475590E 00
79	84	0.456733E 00	79	87	0.467554E 00	79	88	0.439365E 00
79	89	0.415544E 00	79	92	0.380613E 00	79	93	0.375801E 00
79	94	0.371379E 00	79	97	0.273341E 00	79	98	0.300365E 00
79	99	0.321186E 00	79	103	0.228868E 00	79	104	0.271611E 00
79	107	0.107275E 00	79	108	0.171723E 00	79	109	0.228405E 00
79	112	0.680398E-01	79	113	0.133165E 00	79	114	0.194607E 00
79	117	0.491290E-01	79	118	0.109716E 00	79	119	0.170789E 00
80	2	0.112173E 00	80	3	0.160006E 00	80	4	0.212611E 00
80	7	0.107765E 00	80	8	0.153900E 00	80	9	0.205051E 00
80	12	0.101613E 00	80	13	0.149164E 00	80	14	0.200700E 00
80	17	0.961178E-01	80	18	0.146879E 00	80	19	0.199765E 00
80	23	0.149875E 00	80	24	0.202559E 00	80	27	0.110441E 00
80	28	0.158597E 00	80	29	0.209141E 00	80	32	0.128759E 00
80	33	0.171512E 00	80	34	0.218799E 00	80	37	0.144733E 00

80	38	0.184765E 00	80	39	0.230623E 00	80	42	0.154933E 00
80	43	0.196616E 00	80	44	0.243991E 00	80	47	0.159769E 00
80	48	0.207375E 00	80	49	0.259278E 00	80	52	0.162166E 00
80	53	0.219763E 00	80	54	0.277829E 00	80	57	0.171439E 00
80	58	0.238162E 00	80	59	0.301386E 00	80	63	0.268445E 00
80	64	0.330324E 00	80	67	0.255729E 00	80	68	0.308288E 00
80	69	0.362736E 00	80	72	0.318811E 00	80	73	0.349339E 00
80	74	0.391366E 00	80	77	0.365282E 00	80	78	0.375898E 00
80	79	0.414732E 00	80	82	0.378183E 00	80	83	0.384004E 00
80	84	0.408022E 00	80	87	0.355512E 00	80	88	0.365993E 00
80	89	0.390453E 00	80	92	0.301817E 00	80	93	0.327905E 00
80	94	0.360447E 00	80	97	0.233160E 00	80	98	0.279856E 00
80	99	0.325648E 00	80	103	0.235280E 00	80	104	0.291600E 00
80	107	0.137065E 00	80	108	0.201596E 00	80	109	0.262533E 00
80	112	0.121501E 00	80	113	0.180784E 00	80	114	0.240037E 00
80	117	0.115827E 00	80	118	0.168139E 00	80	119	0.223870E 00
81	2	-0.177234E 00	81	3	-0.845888E-01	81	4	0.473270E-02
81	7	-0.160565E 00	81	8	-0.868629E-01	81	9	-0.104163E-01
81	12	-0.125446E 00	81	13	-0.749949E-01	81	14	-0.142516E-01
81	17	-0.934151E-01	81	18	-0.613071E-01	81	19	-0.133894E-01
81	23	-0.557261E-01	81	24	-0.125201E-01	81	27	-0.934623E-01
81	28	-0.613513E-01	81	29	-0.134344E-01	81	32	-0.125576E 00
81	33	-0.750625E-01	81	34	-0.143232E-01	81	37	-0.160730E 00
81	38	-0.869861E-01	81	39	-0.104920E-01	81	42	-0.177237E 00
81	43	-0.845910E-01	81	44	0.473130E-02	81	47	-0.158762E 00
81	48	-0.557187E-01	81	49	0.378539E-01	81	52	-0.913933E-01
81	53	0.981440E-02	81	54	0.939797E-01	81	57	0.384398E-01
81	58	0.118295E 00	81	59	0.174545E 00	81	63	0.269520E 00
81	64	0.275177E 00	81	67	0.493956E 00	81	68	0.448034E 00
81	69	0.384784E 00	81	72	0.767229E 00	81	73	0.625463E 00
81	74	0.485480E 00	81	77	0.994001E 00	81	78	0.759272E 00
81	79	0.556992E 00	81	82	0.108968E 01	81	83	0.808442E 00
81	84	0.583088E 00	81	87	0.994030E 00	81	88	0.759242E 00
81	89	0.556936E 00	81	92	0.767186E 00	81	93	0.625504E 00
81	94	0.485399E 00	81	97	0.493869E 00	81	98	0.447980E 00
81	99	0.384756E 00	81	103	0.269392E 00	81	104	0.275176E 00
81	107	0.383701E-01	81	108	0.118239E 00	81	109	0.174511E 00
81	112	-0.914114E-01	81	113	0.981710E-02	81	114	0.939088E-01
81	117	-0.158778E 00	81	118	-0.557527E-01	81	119	0.377959E-01
82	2	-0.986175E-01	82	3	-0.206643E-01	82	4	0.558736E-01
82	7	-0.889097E-01	82	8	-0.250261E-01	82	9	0.419755E-01
82	12	-0.662281E-01	82	13	-0.188150E-01	82	14	0.370320E-01
82	17	-0.457043E-01	82	18	-0.107414E-01	82	19	0.362869E-01
82	23	-0.737300E-02	82	24	0.364363E-01	82	27	-0.457244E-01
82	28	-0.107671E-01	82	29	0.362536E-01	82	32	-0.663080E-01
82	33	-0.188509E-01	82	34	0.369837E-01	82	37	-0.890137E-01
82	38	-0.251037E-01	82	39	0.419292E-01	82	42	-0.986202E-01
82	43	-0.206662E-01	82	44	0.558724E-01	82	47	-0.830281E-01
82	48	0.348970E-02	82	49	0.836936E-01	82	52	-0.315141E-01
82	53	0.553867E-01	82	54	0.129403E 00	82	57	0.677922E-01
82	58	0.140555E 00	82	59	0.194425E 00	82	63	0.260240E 00
82	64	0.275661E 00	82	67	0.425689E 00	82	68	0.402626E 00
82	69	0.364770E 00	82	72	0.640064E 00	82	73	0.546382E 00
82	74	0.447687E 00	82	77	0.825641E 00	82	78	0.658629E 00
82	79	0.507458E 00	82	82	0.901787E 00	82	83	0.708097E 00
82	84	0.527841E 00	82	87	0.825570E 00	82	88	0.658548E 00
82	89	0.507376E 00	82	92	0.639971E 00	82	93	0.546364E 00

82	94	0.447595E 00	82	97	0.425578E 00	82	98	0.402555E 00
82	99	0.364730E 00	82	103	0.260128E 00	82	104	0.275650E 00
82	107	0.677567E-01	82	108	0.140518E 00	82	109	0.194396E 00
82	112	-0.314999E-01	82	113	0.554075E-01	82	114	0.129352E 00
82	117	-0.830064E-01	82	118	0.348490E-02	82	119	0.836582E-01
83	2	-0.206554E-01	83	3	0.444160E-01	83	4	0.110097E 00
83	7	-0.173850E-01	83	8	0.381415E-01	83	9	0.973333E-01
83	12	-0.660860E-02	83	13	0.389322E-01	83	14	0.912745E-01
83	17	0.273980E-02	83	18	0.415633E-01	83	19	0.889475E-01
83	23	0.427795E-01	83	24	0.883880E-01	83	27	0.273650E-02
83	28	0.415480E-01	83	29	0.889201E-01	83	32	-0.665920E-02
83	33	0.389131E-01	83	34	0.912389E-01	83	37	-0.174550E-01
83	38	0.380891E-01	83	39	0.973027E-01	83	42	-0.206575E-01
83	43	0.444144E-01	83	44	0.110096E 00	83	47	-0.822450E-02
83	48	0.639105E-01	83	49	0.132941E 00	83	52	0.276486E-01
83	53	0.102635E 00	83	54	0.168872E 00	83	57	0.974203E-01
83	58	0.165522E 00	83	59	0.219379E 00	83	63	0.255238E 00
83	64	0.282711E 00	83	67	0.361580E 00	83	68	0.364021E 00
83	69	0.353234E 00	83	72	0.524178E 00	83	73	0.474338E 00
83	74	0.421725E 00	83	77	0.654596E 00	83	78	0.575622E 00
83	79	0.473687E 00	83	82	0.714011E 00	83	83	0.607062E 00
83	84	0.499349E 00	83	87	0.654505E 00	83	88	0.575547E 00
83	89	0.473626E 00	83	92	0.524078E 00	83	93	0.474304E 00
83	94	0.421660E 00	83	97	0.361468E 00	83	98	0.363959E 00
83	99	0.353214E 00	83	103	0.255156E 00	83	104	0.282712E 00
83	107	0.974146E-01	83	108	0.165506E 00	83	109	0.219366E 00
83	112	0.276829E-01	83	113	0.102673E 00	83	114	0.168848E 00
83	117	-0.818100E-02	83	118	0.639293E-01	83	119	0.132932E 00
84	2	0.559776E-01	84	3	0.110194E 00	84	4	0.167207E 00
84	7	0.535921E-01	84	8	0.102352E 00	84	9	0.155538E 00
84	12	0.532181E-01	84	13	0.981024E-01	84	14	0.148424E 00
84	17	0.518628E-01	84	18	0.955566E-01	84	19	0.144587E 00
84	23	0.947165E-01	84	24	0.143349E 00	84	27	0.518787E-01
84	28	0.955536E-01	84	29	0.144567E 00	84	32	0.532002E-01
84	33	0.981044E-01	84	34	0.148405E 00	84	37	0.535616E-01
84	38	0.102331E 00	84	39	0.155530E 00	84	42	0.559762E-01
84	43	0.110193E 00	84	44	0.167207E 00	84	47	0.647427E-01
84	48	0.124912E 00	84	49	0.185316E 00	84	52	0.850574E-01
84	53	0.150763E 00	84	54	0.212001E 00	84	57	0.126283E 00
84	58	0.192195E 00	84	59	0.248841E 00	84	63	0.253320E 00
84	64	0.295288E 00	84	67	0.302370E 00	84	68	0.329309E 00
84	69	0.348261E 00	84	72	0.414484E 00	84	73	0.409134E 00
84	74	0.401539E 00	84	77	0.499727E 00	84	78	0.471845E 00
84	79	0.456773E 00	84	82	0.528637E 00	84	83	0.504016E 00
84	84	0.456187E 00	84	87	0.499738E 00	84	88	0.471843E 00
84	89	0.456748E 00	84	92	0.414472E 00	84	93	0.409140E 00
84	94	0.401518E 00	84	97	0.302314E 00	84	98	0.329290E 00
84	99	0.348269E 00	84	103	0.253276E 00	84	104	0.295296E 00
84	107	0.126293E 00	84	108	0.192187E 00	84	109	0.248825E 00
84	112	0.850739E-01	84	113	0.150786E 00	84	114	0.211972E 00
84	117	0.647563E-01	84	118	0.124911E 00	84	119	0.185296E 00
85	2	0.129724E 00	85	3	0.175253E 00	85	4	0.225914E 00
85	7	0.122751E 00	85	8	0.166361E 00	85	9	0.215370E 00
85	12	0.112288E 00	85	13	0.157626E 00	85	14	0.207334E 00
85	17	0.100930E 00	85	18	0.150300E 00	85	19	0.202114E 00
85	23	0.147543E 00	85	24	0.200243E 00	85	27	0.100951E 00
85	28	0.150297E 00	85	29	0.202092E 00	85	32	0.112275E 00

85	33	0.157627E 00	85	34	0.207312E 00	85	37	0.122722E 00
85	38	0.166339E 00	85	39	0.215358E 00	85	42	0.129723E 00
85	43	0.175253E 00	85	44	0.225913E 00	85	47	0.134137E 00
85	48	0.184965E 00	85	49	0.239478E 00	85	52	0.139008E 00
85	53	0.198208E 00	85	54	0.257402E 00	85	57	0.153015E 00
85	58	0.219090E 00	85	59	0.281283E 00	85	63	0.252857E 00
85	64	0.311436E 00	85	67	0.248229E 00	85	68	0.297317E 00
85	69	0.346135E 00	85	72	0.316758E 00	85	73	0.344193E 00
85	74	0.380544E 00	85	77	0.368535E 00	85	78	0.378913E 00
85	79	0.406286E 00	85	82	0.387546E 00	85	83	0.390023E 00
85	84	0.422257E 00	85	87	0.368476E 00	85	88	0.378866E 00
85	89	0.406248E 00	85	92	0.316696E 00	85	93	0.344148E 00
85	94	0.380521E 00	85	97	0.248146E 00	85	98	0.297280E 00
85	99	0.346140E 00	85	103	0.252824E 00	85	104	0.311439E 00
85	107	0.153048E 00	85	108	0.219095E 00	85	109	0.281271E 00
85	112	0.139043E 00	85	113	0.198245E 00	85	114	0.257391E 00
85	117	0.134172E 00	85	118	0.184985E 00	85	119	0.239480E 00
86	2	-0.172730E 00	86	3	-0.810283E-01	86	4	0.640300E-02
86	7	-0.159533E 00	86	8	-0.854881E-01	86	9	-0.976750E-02
86	12	-0.125485E 00	86	13	-0.741658E-01	86	14	-0.137591E-01
86	17	-0.916884E-01	86	18	-0.591383E-01	86	19	-0.120910E-01
86	23	-0.504553E-01	86	24	-0.963850E-02	86	27	-0.804231E-01
86	28	-0.519339E-01	86	29	-0.867190E-02	86	32	-0.105266E 00
86	33	-0.616283E-01	86	34	-0.812980E-02	86	37	-0.134934E 00
86	38	-0.712240E-01	86	39	-0.421190E-02	86	42	-0.150682E 00
86	43	-0.699703E-01	86	44	0.869560E-02	86	47	-0.137634E 00
86	48	-0.467574E-01	86	49	0.366779E-01	86	52	-0.832999E-01
86	53	0.755160E-02	86	54	0.843422E-01	86	57	0.248234E-01
86	58	0.989479E-01	86	59	0.153436E 00	86	63	0.227757E 00
86	58	0.989479E-01	86	59	0.153436E 00	86	63	0.227757E 00
86	64	0.241044E 00	86	67	0.410074E 00	86	68	0.382485E 00
86	69	0.338833E 00	86	72	0.646733E 00	86	73	0.541851E 00
86	74	0.432876E 00	86	77	0.857176E 00	86	78	0.674670E 00
86	79	0.505992E 00	86	82	0.986328E 00	86	83	0.746352E 00
86	84	0.541422E 00	86	87	0.979743E 00	86	88	0.729325E 00
86	89	0.530482E 00	86	92	0.797113E 00	86	93	0.626434E 00
86	94	0.473494E 00	86	97	0.528883E 00	86	98	0.462790E 00
86	99	0.383702E 00	86	103	0.286105E 00	86	104	0.279544E 00
86	107	0.600127E-01	86	108	0.132378E 00	86	109	0.180177E 00
86	112	-0.756701E-01	86	113	0.204826E-01	86	114	0.987337E-01
86	117	-0.149044E 00	86	118	-0.488413E-01	86	119	0.410351E-01
87	2	-0.831861E-01	87	3	-0.835370E-02	87	4	0.645477E-01
87	7	-0.775512E-01	87	8	-0.155882E-01	87	9	0.488689E-01
87	12	-0.583577E-01	87	13	-0.118539E-01	87	14	0.422816E-01
87	17	-0.400111E-01	87	18	-0.543620E-02	87	19	0.402411E-01
87	23	-0.267710E-02	87	24	0.394923E-01	87	27	-0.391236E-01
87	28	-0.584590E-02	87	29	0.386569E-01	87	32	-0.575192E-01
87	33	-0.134464E-01	87	34	0.386181E-01	87	37	-0.785429E-01
87	38	-0.198747E-01	87	39	0.421761E-01	87	42	-0.888029E-01
87	43	-0.173348E-01	87	44	0.535109E-01	87	47	-0.773149E-01
87	48	0.234340E-02	87	49	0.770766E-01	87	52	-0.343307E-01
87	53	0.464283E-01	87	54	0.116552E 00	87	57	0.509498E-01
87	58	0.120061E 00	87	59	0.173462E 00	87	63	0.224479E 00
87	64	0.245601E 00	87	67	0.361485E 00	87	68	0.350549E 00
87	69	0.326382E 00	87	72	0.553500E 00	87	73	0.480628E 00
87	74	0.404660E 00	87	77	0.718370E 00	87	78	0.589914E 00
87	79	0.466634E 00	87	82	0.825499E 00	87	83	0.652828E 00

87	84	0.498268E 00	87	87	0.818505E 00	87	88	0.648912E 00
87	89	0.489289E 00	87	92	0.671164E 00	87	93	0.555946E 00
87	94	0.444422E 00	87	97	0.451912E 00	87	98	0.420156E 00
87	99	0.370657E 00	87	103	0.279191E 00	87	104	0.285904E 00
87	107	0.920055E-01	87	108	0.159084E 00	87	109	0.206037E 00
87	112	-0.913630E-02	87	113	0.726482E-01	87	114	0.140759E 00
87	117	-0.636972E-01	87	118	0.185336E-01	87	119	0.939383E-01
88	2	0.337030E-02	88	3	0.638115E-01	88	4	0.124739E 00
88	7	0.219060E-02	88	8	0.541308E-01	88	9	0.109515E 00
88	12	0.759070E-02	88	13	0.508831E-01	88	14	0.100545E 00
88	17	0.115766E-01	88	18	0.494029E-01	88	19	0.951501E-01
88	23	0.469405E-01	88	24	0.916013E-01	88	27	0.390390E-02
88	28	0.426724E-01	88	29	0.893422E-01	88	32	-0.753620E-02
88	33	0.375718E-01	88	34	0.890312E-01	88	37	-0.198115E-01
88	38	0.344879E-01	88	39	0.924563E-01	88	42	-0.248802E-01
88	43	0.382351E-01	88	44	0.102316E 00	88	47	-0.153426E-01
88	48	0.543026E-01	88	49	0.121649E 00	88	52	0.159538E-01
88	53	0.881793E-01	88	54	0.153224E 00	88	57	0.784113E-01
88	58	0.144326E 00	88	59	0.198441E 00	88	63	0.225026E 00
88	64	0.255894E 00	88	67	0.316171E 00	88	68	0.323515E 00
88	69	0.320840E 00	88	72	0.464601E 00	88	73	0.426317E 00
88	74	0.384881E 00	88	77	0.590342E 00	88	78	0.511708E 00
88	79	0.438666E 00	88	82	0.660105E 00	88	83	0.575496E 00
88	84	0.469824E 00	88	87	0.654819E 00	88	88	0.565833E 00
88	89	0.473417E 00	88	92	0.539738E 00	88	93	0.500868E 00
88	94	0.429484E 00	88	97	0.383066E 00	88	98	0.382241E 00
88	99	0.367642E 00	88	103	0.276518E 00	88	104	0.298903E 00
88	107	0.123179E 00	88	108	0.187651E 00	88	109	0.236613E 00
88	112	0.549691E-01	88	113	0.125255E 00	88	114	0.186105E 00
88	117	0.185766E-01	88	118	0.855870E-01	88	119	0.149308E 00
89	2	0.836914E-01	89	3	0.132954E 00	89	4	0.185247E 00
89	7	0.770653E-01	89	8	0.121613E 00	89	9	0.170715E 00
89	12	0.705304E-01	89	13	0.112552E 00	89	14	0.159916E 00
89	17	0.620794E-01	89	18	0.104486E 00	89	19	0.151895E 00
89	23	0.980724E-01	89	24	0.146315E 00	89	27	0.490679E-01
89	28	0.937721E-01	89	29	0.143333E 00	89	32	0.455242E-01
89	33	0.919164E-01	89	34	0.143303E 00	89	37	0.422965E-01
89	38	0.925283E-01	89	39	0.146972E 00	89	42	0.421616E-01
89	43	0.974867E-01	89	44	0.155578E 00	89	47	0.491313E-01
89	48	0.109730E 00	89	49	0.170818E 00	89	52	0.680379E-01
89	53	0.133155E 00	89	54	0.194646E 00	89	57	0.107277E 00
89	58	0.171742E 00	89	59	0.228432E 00	89	63	0.228920E 00
89	64	0.271616E 00	89	67	0.273404E 00	89	68	0.300394E 00
89	69	0.321189E 00	89	72	0.380634E 00	89	73	0.375805E 00
89	74	0.371409E 00	89	77	0.467545E 00	89	78	0.439374E 00
89	79	0.415581E 00	89	82	0.508786E 00	89	83	0.475589E 00
89	84	0.456733E 00	89	87	0.490110E 00	89	88	0.478104E 00
89	89	0.440826E 00	89	92	0.420390E 00	89	93	0.421912E 00
89	94	0.428931E 00	89	97	0.316421E 00	89	98	0.347624E 00
89	99	0.367572E 00	89	103	0.273853E 00	89	104	0.315326E 00
89	107	0.150492E 00	89	108	0.215042E 00	89	109	0.269421E 00
89	112	0.113109E 00	89	113	0.175267E 00	89	114	0.232651E 00
89	117	0.941350E-01	89	118	0.149460E 00	89	119	0.205193E 00
90	2	0.154934E 00	90	3	0.196617E 00	90	4	0.243992E 00
90	7	0.144745E 00	90	8	0.184773E 00	90	9	0.230622E 00
90	12	0.128759E 00	90	13	0.171502E 00	90	14	0.218810E 00
90	17	0.110410E 00	90	18	0.158592E 00	90	19	0.209158E 00

90	23	0.149870E	00	90	24	0.202559E	00	90	27	0.961417E	-01
90	28	0.146879E	00	90	29	0.199746E	00	90	32	0.101610E	00
90	33	0.149174E	00	90	34	0.200683E	00	90	37	0.107751E	00
90	38	0.153888E	00	90	39	0.205045E	00	90	42	0.112173E	00
90	43	0.160005E	00	90	44	0.212611E	00	90	47	0.115809E	00
90	48	0.168131E	00	90	49	0.223875E	00	90	52	0.121478E	00
90	53	0.180755E	00	90	54	0.240053E	00	90	57	0.137036E	00
90	58	0.201593E	00	90	59	0.262546E	00	90	63	0.235305E	00
90	64	0.291593E	00	90	67	0.233218E	00	90	68	0.279874E	00
90	69	0.325433E	00	90	72	0.301842E	00	90	73	0.327921E	00
90	74	0.360454E	00	90	77	0.355522E	00	90	78	0.366005E	00
90	79	0.390472E	00	90	82	0.378183E	00	90	83	0.384004E	00
90	84	0.408022E	00	90	87	0.365257E	00	90	88	0.375878E	00
90	89	0.414716E	00	90	92	0.318777E	00	90	93	0.349314E	00
90	94	0.391360E	00	90	97	0.255665E	00	90	98	0.308267E	00
90	99	0.362752E	00	90	103	0.268423E	00	90	104	0.330331E	00
90	107	0.171477E	00	90	108	0.238170E	00	90	109	0.301374E	00
90	112	0.162198E	00	90	113	0.219798E	00	90	114	0.277815E	00
90	117	0.159799E	00	90	118	0.207390E	00	90	119	0.259274E	00
91	2	-0.125499E	00	91	3	-0.510458E	-01	91	4	0.189527E	-01
91	7	-0.121101E	00	91	8	-0.594836E	-01	91	9	0.258040E	-02
91	12	-0.973018E	-01	91	13	-0.534124E	-01	91	14	-0.294840E	-02
91	17	-0.712010E	-01	91	18	-0.425627E	-01	91	19	-0.286490E	-02
91	23	-0.352933E	-01	91	24	-0.126120E	-02	91	27	-0.585787E	-01
91	28	-0.351948E	-01	91	29	-0.295600E	-03	91	32	-0.753705E	-01
91	33	-0.414098E	-01	91	34	0.441000E	-03	91	37	-0.965307E	-01
91	38	-0.480533E	-01	91	39	0.350560E	-02	91	42	-0.108348E	00
91	43	-0.472441E	-01	91	44	0.130099E	-01	91	47	-0.999939E	-01
91	48	-0.309475E	-01	91	49	0.332851E	-01	91	52	-0.620156E	-01
91	53	0.779160E	-02	91	54	0.679227E	-01	91	57	0.151326E	-01
91	58	0.736362E	-01	91	59	0.118454E	00	91	63	0.167118E	00
91	64	0.183209E	00	91	67	0.292962E	00	91	68	0.280836E	00
91	69	0.256780E	00	91	72	0.466888E	00	91	73	0.400713E	00
91	74	0.329916E	00	91	77	0.626845E	00	91	78	0.506352E	00
91	79	0.390885E	00	91	82	0.739367E	00	91	83	0.575890E	00
91	84	0.427242E	00	91	87	0.775827E	00	91	88	0.588038E	00
91	89	0.429858E	00	91	92	0.699018E	00	91	93	0.530384E	00
91	94	0.396393E	00	91	97	0.502241E	00	91	98	0.415542E	00
91	99	0.332709E	00	91	103	0.274333E	00	91	104	0.252398E	00
91	107	0.929422E	-01	91	108	0.142831E	00	91	109	0.171294E	00
91	112	-0.283303E	-01	91	113	0.446396E	-01	91	114	0.101898E	00
91	117	-0.978942E	-01	91	118	-0.187358E	-01	91	119	0.509695E	-01
92	2	-0.320204E	-01	92	3	0.272245E	-01	92	4	0.846223E	-01
92	7	-0.348334E	-01	92	8	0.154838E	-01	92	9	0.675827E	-01
92	12	-0.266402E	-01	92	13	0.127930E	-01	92	14	0.580617E	-01
92	17	-0.182497E	-01	92	18	0.129663E	-01	92	19	0.526630E	-01
92	23	0.113614E	-01	92	24	0.489525E	-01	92	27	-0.246993E	-01
92	28	0.626440E	-02	92	29	0.458769E	-01	92	32	-0.403345E	-01
92	33	-0.133740E	-02	92	34	0.440359E	-01	92	37	-0.573072E	-01
92	38	-0.746930E	-02	92	39	0.454504E	-01	92	42	-0.658931E	-01
92	43	-0.642040E	-02	92	44	0.532003E	-01	92	47	-0.579470E	-01
92	48	0.783590E	-02	92	49	0.705729E	-01	92	52	-0.260940E	-01
92	53	0.408065E	-01	92	54	0.100381E	00	92	57	0.379780E	-01
92	58	0.964780E	-01	92	59	0.143881E	00	92	63	0.175935E	00
92	64	0.199660E	00	92	67	0.273093E	00	92	68	0.272872E	00
92	69	0.263149E	00	92	72	0.420392E	00	92	73	0.374967E	00
92	74	0.326451E	00	92	77	0.553074E	00	92	78	0.464017E	00

92	79	0.379851E 00	92	82	0.639496E 00	92	83	0.523255E 00
92	84	0.413273E 00	92	87	0.670697E 00	92	88	0.537800E 00
92	89	0.418718E 00	92	92	0.606006E 00	92	93	0.500464E 00
92	94	0.391804E 00	92	97	0.444036E 00	92	98	0.397897E 00
92	99	0.341827E 00	92	103	0.281131E 00	92	104	0.276249E 00
92	107	0.127505E 00	92	108	0.178422E 00	92	109	0.210360E 00
92	112	0.403331E-01	92	113	0.103606E 00	92	114	0.154389E 00
92	117	-0.951250E-02	92	118	0.546091E-01	92	119	0.112637E 00
93	2	0.551062E-01	93	3	0.102395E 00	93	4	0.150466E 00
93	7	0.461687E-01	93	8	0.879137E-01	93	9	0.132848E 00
93	12	0.405347E-01	93	13	0.775627E-01	93	14	0.119844E 00
93	17	0.332800E-01	93	18	0.684596E-01	93	19	0.109736E 00
93	23	0.594654E-01	93	24	0.101593E 00	93	27	0.117437E-01
93	28	0.505352E-01	93	29	0.953273E-01	93	32	-0.129160E-02
93	33	0.426117E-01	93	34	0.916124E-01	93	37	-0.132883E-01
93	38	0.376274E-01	93	39	0.918600E-01	93	42	-0.185790E-01
93	43	0.390716E-01	93	44	0.980770E-01	93	47	-0.115571E-01
93	48	0.510667E-01	93	49	0.112577E 00	93	52	0.132301E-01
93	53	0.777889E-01	93	54	0.137459E 00	93	57	0.631832E-01
93	58	0.122736E 00	93	59	0.173816E 00	93	63	0.187742E 00
93	64	0.220624E 00	93	67	0.254248E 00	93	68	0.267812E 00
93	69	0.274286E 00	93	72	0.375267E 00	93	73	0.352425E 00
93	74	0.328405E 00	93	77	0.480753E 00	93	78	0.426193E 00
93	79	0.375288E 00	93	82	0.546655E 00	93	83	0.474155E 00
93	84	0.408294E 00	93	87	0.557449E 00	93	88	0.500755E 00
93	89	0.419819E 00	93	92	0.506543E 00	93	93	-0.464738E 00
93	94	0.409819E 00	93	97	0.377656E 00	93	98	0.391965E 00
93	99	0.362229E 00	93	103	0.289478E 00	93	104	0.306976E 00
93	107	0.159164E 00	93	108	0.214343E 00	93	109	0.252995E 00
93	112	0.103729E 00	93	113	0.160714E 00	93	114	0.208628E-00
93	117	0.724431E-01	93	118	0.125046E 00	93	119	0.174920E 00
94	2	0.129359E 00	94	3	0.168843E 00	94	4	0.211880E 00
94	7	0.116511E 00	94	8	0.153158E 00	94	9	0.194501E 00
94	12	0.100344E 00	94	13	0.137425E 00	94	14	0.179338E 00
94	17	0.812210E-01	94	18	0.121740E 00	94	19	0.166174E 00
94	23	0.108143E 00	94	24	0.155360E 00	94	27	0.518875E-01
94	28	0.979289E-01	94	29	0.147558E 00	94	32	0.441766E-01
94	33	0.917068E-01	94	34	0.143323E 00	94	37	0.387905E-01
94	38	0.891369E-01	94	39	0.143319E 00	94	42	0.372424E-01
94	43	0.914344E-01	94	44	0.148459E 00	94	47	0.425446E-01
94	48	0.100745E 00	94	49	0.160002E 00	94	52	0.584689E-01
94	53	0.120107E 00	94	54	0.179458E 00	94	57	0.919077E-01
94	58	0.152756E 00	94	59	0.207894E 00	94	63	0.201548E 00
94	64	0.244832E 00	94	67	0.234074E 00	94	68	0.263032E 00
94	69	0.287782E 00	94	72	0.327024E 00	94	73	0.328765E 00
94	74	0.331851E 00	94	77	0.405207E 00	94	78	0.385277E 00
94	79	0.371399E 00	94	82	0.448495E 00	94	83	0.422339E 00
94	84	0.401481E 00	94	87	0.445854E 00	94	88	0.431462E 00
94	89	0.428909E 00	94	92	0.392819E 00	94	93	0.414575E 00
94	94	0.403470E 00	94	97	0.312881E 00	94	98	0.352905E 00
94	99	0.389356E 00	94	103	0.291924E 00	94	104	0.333236E 00
94	107	0.181193E 00	94	108	0.241865E 00	94	109	0.291952E 00
94	112	0.154877E 00	94	113	0.208983E 00	94	114	0.258562E 00
94	117	0.140945E 00	94	118	0.186245E 00	94	119	0.232612E 00
95	2	0.187994E 00	95	3	0.224206E 00	95	4	0.266925E 00
95	7	0.174030E 00	95	8	0.209293E 00	95	9	0.250888E 00
95	12	0.151262E 00	95	13	0.190900E 00	95	14	0.235157E 00

95	17	0.124612E 00	95	18	0.171722E 00	95	19	0.220821E 00
95	23	0.156604E 00	95	24	0.209283E 00	95	27	0.954047E-01
95	28	0.147835E 00	95	29	0.201724E 00	95	32	0.957870E-01
95	33	0.145404E 00	95	34	0.198393E 00	95	37	0.985628E-01
95	38	0.146500E 00	95	39	0.199080E 00	95	42	0.100962E 00
95	43	0.149950E 00	95	44	0.203496E 00	95	47	0.103635E 00
95	48	0.156109E 00	95	49	0.212003E 00	95	52	0.108880E 00
95	53	0.167008E 00	95	54	0.225560E 00	95	57	0.123546E 00
95	58	0.185874E 00	95	59	0.245342E 00	95	63	0.216832E 00
95	64	0.271534E 00	95	67	0.212793E 00	95	68	0.258178E 00
95	69	0.302781E 00	95	72	0.276835E 00	95	73	0.303505E 00
95	74	0.335491E 00	95	77	0.328443E 00	95	78	0.341268E 00
95	79	0.365038E 00	95	82	0.353089E 00	95	83	0.362543E 00
95	84	0.386802E 00	95	87	0.345507E 00	95	88	0.362466E 00
95	89	0.395779E 00	95	92	0.308348E 00	95	93	0.341211E 00
95	94	0.396519E 00	95	97	0.254920E 00	95	98	0.311356E 00
95	99	0.372137E 00	95	103	0.280857E 00	95	104	0.347451E 00
95	107	0.191703E 00	95	108	0.258215E 00	95	109	0.322483E 00
95	112	0.190645E 00	95	113	0.245164E 00	95	114	0.301205E 00
95	117	0.192685E 00	95	118	0.235319E 00	95	119	0.283274E 00
96	2	-0.223452E-01	96	3	0.154735E-01	96	4	0.500438E-01
96	7	-0.332876E-01	96	8	0.494500E-03	96	9	0.338149E-01
96	12	-0.317976E-01	96	13	-0.542140E-02	96	14	0.240781E-01
96	17	-0.270588E-01	96	18	-0.729130E-02	96	19	0.182786E-01
96	23	-0.958610E-02	96	24	0.143473E-01	96	27	-0.333954E-01
96	28	-0.142337E-01	96	29	0.111644E-01	96	32	-0.462416E-01
96	33	-0.208290E-01	96	34	0.895220E-02	96	37	-0.595584E-01
96	38	-0.262202E-01	96	39	0.904250E-02	96	42	-0.663341E-01
96	43	-0.263390E-01	96	44	0.135802E-01	96	47	-0.609386E-01
96	48	-0.170252E-01	96	49	0.247872E-01	96	52	-0.386449E-01
96	53	0.521790E-02	96	54	0.444809E-01	96	57	0.537110E-02
96	58	0.427131E-01	96	59	0.734019E-01	96	63	0.956032E-01
96	64	0.110671E 00	96	67	0.160718E 00	96	68	0.160120E 00
96	69	0.153528E 00	96	72	0.258267E 00	96	73	0.229154E 00
96	74	0.197298E 00	96	77	0.350364E 00	96	78	0.292497E 00
96	79	0.236064E 00	96	82	0.419889E 00	96	83	0.339294E 00
96	84	0.263284E 00	96	87	0.454719E 00	96	88	0.360403E 00
96	89	0.274125E 00	96	92	0.443266E 00	96	93	0.348691E 00
96	94	0.265222E 00	96	97	0.378412E 00	96	98	0.300813E 00
96	99	0.237894E 00	96	103	0.229011E 00	96	104	0.197312E 00
96	107	0.141552E 00	96	108	0.152609E 00	96	109	0.151760E 00
96	112	0.605809E-01	96	113	0.893043E-01	96	114	0.109146E 00
96	117	0.706070E-02	96	118	0.438423E-01	96	119	0.746478E-01
97	2	0.665249E-01	97	3	0.964048E-01	97	4	0.125420E 00
97	7	0.499092E-01	97	8	0.775117E-01	97	9	0.106485E 00
97	12	0.371705E-01	97	13	0.624844E-01	97	14	0.912510E-01
97	17	0.241293E-01	97	18	0.490064E-01	97	19	0.784781E-01
97	23	0.358841E-01	97	24	0.675060E-01	97	27	-0.744330E-02
97	28	0.231368E-01	97	29	0.583545E-01	97	32	-0.244548E-01
97	33	0.118082E-01	97	34	0.517471E-01	97	37	-0.387109E-01
97	38	0.407530E-02	97	39	0.489987E-01	97	42	-0.451940E-01
97	43	0.301250E-02	97	44	0.518504E-01	97	47	-0.395089E-01
97	48	0.118414E-01	97	49	0.620821E-01	97	52	-0.177580E-01
97	53	0.334894E-01	97	54	0.811790E-01	97	57	0.246422E-01
97	58	0.700746E-01	97	59	0.109719E 00	97	63	0.122088E 00
97	64	0.146756E 00	97	67	0.177007E 00	97	68	0.185752E 00
97	69	0.189530E 00	97	72	0.272767E 00	97	73	0.253740E 00

97	74	0.233364E 00	97	77	0.360828E 00	97	78	0.315429E 00
97	79	0.272518E 00	97	82	0.424940E 00	97	83	0.360600E 00
97	84	0.301238E 00	97	87	0.451279E 00	97	88	0.381989E 00
97	89	0.314971E 00	97	92	0.443481E 00	97	93	0.375560E 00
97	94	0.310961E 00	97	97	0.378260E 00	97	98	0.342651E 00
97	99	0.288456E 00	97	103	0.275441E 00	97	104	0.255725E 00
97	107	0.182262E 00	97	108	0.208400E 00	97	109	0.217070E 00
97	112	0.126588E 00	97	113	0.158366E 00	97	114	0.180153E 00
97	117	0.907800E-01	97	118	0.122194E 00	97	119	0.149541E 00
98	2	0.140217E 00	98	3	0.165188E 00	98	4	0.191779E 00
98	7	0.119791E 00	98	8	0.144020E 00	98	9	0.171354E 00
98	12	0.962694E-01	98	13	0.122511E 00	98	14	0.152432E 00
98	17	0.699790E-01	98	18	0.100802E 00	98	17	0.134951E 00
98	23	0.806015E-01	98	24	0.119427E 00	98	27	0.231803E-01
98	28	0.634332E-01	98	29	0.106736E 00	98	32	0.634350E-02
98	33	0.505331E-01	98	34	0.978079E-01	98	37	-0.572730E-02
98	38	0.426906E-01	98	39	0.936736E-01	98	42	-0.105842E-01
98	43	0.416340E-01	98	44	0.954760E-01	98	47	-0.525590E-02
98	48	0.494872E-01	98	49	0.104437E 00	98	52	0.132309E-01
98	53	0.685639E-01	98	54	0.121699E 00	98	57	0.494339E-01
98	58	0.100922E 00	98	59	0.147797E 00	98	63	0.147753E 00
98	64	0.181936E 00	98	67	0.186110E 00	98	68	0.205719E 00
98	69	0.221681E 00	98	72	0.273089E 00	98	73	0.267808E 00
98	74	0.262738E 00	98	77	0.350653E 00	98	78	0.323432E 00
98	79	0.300025E 00	98	82	0.402814E 00	98	83	0.363885E 00
98	84	0.328774E 00	98	87	0.420658E 00	98	88	0.382201E 00
98	89	0.346807E 00	98	92	0.399792E 00	98	93	0.391973E 00
98	94	0.350878E 00	98	97	0.348813E 00	98	98	0.358293E 00
98	99	0.343952E 00	98	103	0.311952E 00	98	104	0.309448E 00
98	107	0.209042E 00	98	108	0.248844E 00	98	109	0.274197E 00
98	112	0.178519E 00	98	113	0.214235E 00	98	114	0.241328E 00
98	117	0.158886E 00	98	118	0.187402E 00	98	119	0.214593E 00
99	2	0.194455E 00	99	3	0.219388E 00	99	4	0.248712E 00
99	7	0.173490E 00	99	8	0.198419E 00	99	9	0.228288E 00
99	12	0.143935E 00	99	13	0.173836E 00	99	14	0.207778E 00
99	17	0.109875E 00	99	18	0.147870E 00	99	19	0.188088E 00
99	23	0.124696E 00	99	24	0.170631E 00	99	27	0.585962E-01
99	28	0.106888E 00	99	29	0.156840E 00	99	32	0.460876E-01
99	33	0.954615E-01	99	34	0.147573E 00	99	37	0.388675E-01
99	38	0.894732E-01	99	39	0.143359E 00	99	42	0.365063E-01
99	43	0.891018E-01	99	44	0.144606E 00	99	47	0.404857E-01
99	48	0.953192E-01	99	49	0.151948E 00	99	52	0.529990E-01
99	53	0.109938E 00	99	54	0.166248E 00	99	57	0.789745E-01
99	58	0.135199E 00	99	59	0.188154E 00	99	63	0.173355E 00
99	64	0.217251E 00	99	67	0.190070E 00	99	68	0.221908E 00
99	69	0.251676E 00	99	72	0.263551E 00	99	73	0.274536E 00
99	74	0.287755E 00	99	77	0.326735E 00	99	78	0.321070E 00
99	79	0.321152E 00	99	82	0.365199E 00	99	83	0.353536E 00
99	84	0.348198E 00	99	87	0.371541E 00	99	88	0.368313E 00
99	89	0.367522E 00	99	92	0.343390E 00	99	93	0.364268E 00
99	94	0.389330E 00	99	97	0.289769E 00	99	98	0.348667E 00
99	99	0.365988E 00	99	103	0.307229E 00	99	104	0.361113E 00
99	107	0.218444E 00	99	108	0.274983E 00	99	109	0.319079E 00
99	112	0.210958E 00	99	113	0.253434E 00	99	114	0.291909E 00
99	117	0.206275E 00	99	118	0.236777E 00	99	119	0.269342E 00
100	2	0.228006E 00	100	3	0.257407E 00	100	4	0.294458E 00
100	7	0.210024E 00	100	8	0.239504E 00	100	9	0.275976E 00

100	12	0.179452E	00	100	13	0.215540E	00	100	14	0.256226E	00
100	17	0.143292E	00	100	18	0.189460E	00	100	19	0.236961E	00
100	23	0.167475E	00	100	24	0.220244E	00	100	27	0.982549E	-01
100	28	0.152774E	00	100	29	0.207792E	00	100	32	0.940483E	-01
100	33	0.145771E	00	100	34	0.200136E	00	100	37	0.941342E	-01
100	38	0.143492E	00	100	39	0.197117E	00	100	42	0.949826E	-01
100	43	0.144412E	00	100	44	0.198292E	00	100	47	0.965875E	-01
100	48	0.148345E	00	100	49	0.203709E	00	100	52	0.100549E	00
100	53	0.156745E	00	100	54	0.214027E	00	100	57	0.112588E	00
100	58	0.172284E	00	100	59	0.230165E	00	100	63	0.198612E	00
100	64	0.252281E	00	100	67	0.189348E	00	100	68	0.234426E	00
100	69	0.279284E	00	100	72	0.245398E	00	100	73	0.274417E	00
100	74	0.308220E	00	100	77	0.291571E	00	100	78	0.308899E	00
100	79	0.335369E	00	100	82	0.315701E	00	100	83	0.330749E	00
100	84	0.357188E	00	100	87	0.313283E	00	100	88	0.336102E	00
100	89	0.371651E	00	100	92	0.285813E	00	100	93	0.325913E	00
100	94	0.376496E	00	100	97	0.246598E	00	100	98	0.304742E	00
100	99	0.378259E	00	100	103	0.288732E	00	100	104	0.359692E	00
100	107	0.212367E	00	100	108	0.277821E	00	100	109	0.343836E	00
100	112	0.223010E	00	100	113	0.273337E	00	100	114	0.327124E	00
100	117	0.231695E	00	100	118	0.268006E	00	100	119	0.311203E	00
101	2	0.171335E	00	101	3	0.153826E	00	101	4	0.136357E	00
101	7	0.134245E	00	101	8	0.125129E	00	101	9	0.116026E	00
101	12	0.942882E	-01	101	13	0.942911E	-01	101	14	0.941834E	-01
101	17	0.544984E	-01	101	18	0.634114E	-01	101	19	0.723236E	-01
101	23	0.346095E	-01	101	24	0.519382E	-01	101	27	-0.146377E	-01
101	28	0.989120E	-02	101	29	0.344154E	-01	101	32	-0.391666E	-01
101	33	-0.909710E	-02	101	34	0.209654E	-01	101	37	-0.545722E	-01
101	38	-0.210277E	-01	101	39	0.125077E	-01	101	42	-0.598425E	-01
101	43	-0.251024E	-01	101	44	0.962810E	-02	101	47	-0.545711E	-01
101	48	-0.210249E	-01	101	49	0.125121E	-01	101	52	-0.391660E	-01
101	53	-0.910760E	-02	101	54	0.209751E	-01	101	57	-0.146377E	-01
101	58	0.989300E	-02	101	59	0.344190E	-01	101	63	0.346230E	-01
101	64	0.519307E	-01	101	67	0.545119E	-01	101	68	0.634134E	-01
101	69	0.723141E	-01	101	72	0.943842E	-01	101	73	0.942820E	-01
101	74	0.941830E	-01	101	77	0.134224E	00	101	78	0.125122E	00
101	79	0.116033E	00	101	82	0.171331E	00	101	83	0.153822E	00
101	84	0.136354E	00	101	87	0.203057E	00	101	88	0.178399E	00
101	89	0.153775E	00	101	92	0.227411E	00	101	93	0.197157E	00
101	94	0.167102E	00	101	97	0.241925E	00	101	98	0.208954E	00
101	99	0.175446E	00	101	103	0.212602E	00	101	104	0.178374E	00
101	107	0.241911E	00	101	108	0.208952E	00	101	109	0.175458E	00
101	112	0.227413E	00	101	113	0.197154E	00	101	114	0.167109E	00
101	117	0.203076E	00	101	118	0.178407E	00	101	119	0.153771E	00
102	2	0.217205E	00	102	3	0.203861E	00	102	4	0.191948E	00
102	7	0.180962E	00	102	8	0.174729E	00	102	9	0.170141E	00
102	12	0.136345E	00	102	13	0.140578E	00	102	14	0.145706E	00
102	17	0.886756E	-01	102	18	0.104681E	00	102	19	0.120581E	00
102	23	0.710917E	-01	102	24	0.969018E	-01	102	27	0.880150E	-02
102	28	0.429326E	-01	102	29	0.766526E	-01	102	32	-0.167890E	-01
102	33	0.221851E	-01	102	34	0.613017E	-01	102	37	-0.322390E	-01
102	38	0.948260E	-02	102	39	0.517901E	-01	102	42	-0.374654E	-01
102	43	0.521370E	-02	102	44	0.485882E	-01	102	47	-0.322344E	-01
102	48	0.949260E	-02	102	49	0.518052E	-01	102	52	-0.167860E	-01
102	53	0.221792E	-01	102	54	0.613251E	-01	102	57	0.880350E	-02
102	58	0.429443E	-01	102	59	0.766715E	-01	102	63	0.711218E	-01
102	64	0.969093E	-01	102	67	0.887150E	-01	102	68	0.104705E	00

102	69	0.120588E	00	102	72	0.136370E	00	102	73	0.140596E	00
102	74	0.145730E	00	102	77	0.180977E	00	102	78	0.174753E	00
102	79	0.170175E	00	102	82	0.217201E	00	102	83	0.203858E	00
102	84	0.191946E	00	102	87	0.241914E	00	102	88	0.225927E	00
102	89	0.209854E	00	102	92	0.253926E	00	102	93	0.241257E	00
102	94	0.223211E	00	102	97	0.260758E	00	102	98	0.251251E	00
102	99	0.231586E	00	102	103	0.256270E	00	102	104	0.234228E	00
102	107	0.260800E	00	102	108	0.251275E	00	102	109	0.231606E	00
102	112	0.253999E	00	102	113	0.241298E	00	102	114	0.223236E	00
102	117	0.242000E	00	102	118	0.225981E	00	102	119	0.209876E	00
103	2	0.259902E	00	103	3	0.254744E	00	103	4	0.252589E	00
103	7	0.224232E	00	103	8	0.224625E	00	103	9	0.228299E	00
103	12	0.175810E	00	103	13	0.187467E	00	103	14	0.201029E	00
103	17	0.122111E	00	103	18	0.147555E	00	103	19	0.172941E	00
103	23	0.110601E	00	103	24	0.146616E	00	103	27	0.360496E	-01
103	28	0.805501E	-01	103	29	0.124427E	00	103	32	0.114670E	-01
103	33	0.594163E	-01	103	34	0.107902E	00	103	37	-0.260120E	-02
103	38	0.468795E	-01	103	39	0.978431E	-01	103	42	-0.726960E	-02
103	43	0.427588E	-01	103	44	0.945035E	-01	103	47	-0.257990E	-02
103	48	0.469046E	-01	103	49	0.978720E	-01	103	52	0.114825E	-01
103	53	0.594209E	-01	103	54	0.107941E	00	103	57	0.360575E	-01
103	58	0.805731E	-01	103	59	0.124461E	00	103	63	0.110644E	00
103	64	0.146635E	00	103	67	0.122167E	00	103	68	0.147589E	00
103	69	0.172956E	00	103	72	0.175845E	00	103	73	0.187496E	00
103	74	0.201062E	00	103	77	0.224254E	00	103	78	0.224657E	00
103	79	0.228343E	00	103	82	0.259899E	00	103	83	0.254742E	00
103	84	0.252587E	00	103	87	0.279037E	00	103	88	0.276074E	00
103	89	0.272988E	00	103	92	0.281187E	00	103	93	0.289086E	00
103	94	0.290690E	00	103	97	0.277424E	00	103	98	0.311330E	00
103	99	0.304690E	00	103	103	0.314937E	00	103	104	0.315847E	00
103	107	0.277507E	00	103	108	0.311375E	00	103	109	0.304720E	00
103	112	0.281290E	00	103	113	0.289160E	00	103	114	0.290728E	00
103	117	0.279157E	00	103	118	0.276154E	00	103	119	0.273026E	00
104	2	0.275945E	00	104	3	0.282918E	00	104	4	0.295276E	00
104	7	0.245831E	00	104	8	0.256043E	00	104	9	0.271583E	00
104	12	0.199908E	00	104	13	0.220799E	00	104	14	0.244814E	00
104	17	0.147098E	00	104	18	0.182113E	00	104	19	0.217273E	00
104	23	0.146960E	00	104	24	0.191741E	00	104	27	0.678785E	-01
104	28	0.119640E	00	104	29	0.170690E	00	104	32	0.492323E	-01
104	33	0.101786E	00	104	34	0.155425E	00	104	37	0.397248E	-01
104	38	0.917650E	-01	104	39	0.146380E	00	104	42	0.366647E	-01
104	43	0.885597E	-01	104	44	0.143395E	00	104	47	0.397194E	-01
104	48	0.917611E	-01	104	49	0.146377E	00	104	52	0.492209E	-01
104	53	0.101759E	00	104	54	0.155432E	00	104	57	0.678555E	-01
104	58	0.119631E	00	104	59	0.170691E	00	104	63	0.146967E	00
104	64	0.191722E	00	104	67	0.147123E	00	104	68	0.182109E	00
104	69	0.217242E	00	104	72	0.199898E	00	104	73	0.220785E	00
104	74	0.244797E	00	104	77	0.245800E	00	104	78	0.256023E	00
104	79	0.271577E	00	104	82	0.275943E	00	104	83	0.282916E	00
104	84	0.295275E	00	104	87	0.286427E	00	104	88	0.299308E	00
104	89	0.315346E	00	104	92	0.277355E	00	104	93	0.307813E	00
104	94	0.333311E	00	104	97	0.257599E	00	104	98	0.311657E	00
104	99	0.361238E	00	104	103	0.321303E	00	104	104	0.350337E	00
104	107	0.257640E	00	104	108	0.311662E	00	104	109	0.361229E	00
104	112	0.277373E	00	104	113	0.307828E	00	104	114	0.333297E	00
104	117	0.286443E	00	104	118	0.299312E	00	104	119	0.315332E	00
105	2	0.272073E	00	105	3	0.294057E	00	105	4	0.325260E	00

105	7	0.250422E 00	105	8	0.273632E 00	105	9	0.304725E 00
105	12	0.211690E 00	105	13	0.244064E 00	105	14	0.281049E 00
105	17	0.165379E 00	105	18	0.210815E 00	105	19	0.256794E 00
105	23	0.181738E 00	105	24	0.234803E 00	105	27	0.104081E 00
105	28	0.161058E 00	105	29	0.217399E 00	105	32	0.956659E-01
105	33	0.149622E 00	105	34	0.205410E 00	105	37	0.935161E-01
105	38	0.144146E 00	105	39	0.198684E 00	105	42	0.930732E-01
105	43	0.142606E 00	105	44	0.196556E 00	105	47	0.935259E-01
105	48	0.144160E 00	105	49	0.198702E 00	105	52	0.956681E-01
105	53	0.149615E 00	105	54	0.205441E 00	105	57	0.104067E 00
105	58	0.161070E 00	105	59	0.217429E 00	105	63	0.181768E 00
105	64	0.234814E 00	105	67	0.165437E 00	105	68	0.210843E 00
105	69	0.256795E 00	105	72	0.211719E 00	105	73	0.244094E 00
105	74	0.281066E 00	105	77	0.250437E 00	105	78	0.273653E 00
105	79	0.304757E 00	105	82	0.272071E 00	105	83	0.294056E 00
105	84	0.325260E 00	105	87	0.273463E 00	105	88	0.302908E 00
105	89	0.341497E 00	105	92	0.256066E 00	105	93	0.301503E 00
105	94	0.353809E 00	105	97	0.231345E 00	105	98	0.294577E 00
105	99	0.361575E 00	105	103	0.289838E 00	105	104	0.370586E 00
105	107	0.231416E 00	105	108	0.294606E 00	105	109	0.361578E 00
105	112	0.256132E 00	105	113	0.301560E 00	105	114	0.353827E 00
105	117	0.273533E 00	105	118	0.302960E 00	105	119	0.341526E 00
106	2	0.419894E 00	106	3	0.339298E 00	106	4	0.263286E 00
106	7	0.350123E 00	106	8	0.292250E 00	106	9	0.235809E 00
106	12	0.258040E 00	106	13	0.228955E 00	106	14	0.197063E 00
106	17	0.160527E 00	106	18	0.159930E 00	106	19	0.153340E 00
106	23	0.954252E-01	106	24	0.110513E 00	106	27	0.528580E-02
106	28	0.425909E-01	106	29	0.732490E-01	106	32	-0.386983E-01
106	33	0.513640E-02	106	34	0.443315E-01	106	37	-0.609852E-01
106	38	-0.171133E-01	106	39	0.246545E-01	106	42	-0.663334E-01
106	43	-0.263384E-01	106	44	0.135805E-01	106	47	-0.595526E-01
106	48	-0.262136E-01	106	49	0.905100E-02	106	52	-0.462406E-01
106	53	-0.208481E-01	106	54	0.895140E-02	106	57	-0.334295E-01
106	58	-0.142678E-01	106	59	0.111426E-01	106	63	-0.965400E-02
106	64	0.142910E-01	106	67	-0.271870E-01	106	68	-0.740620E-02
106	69	0.181854E-01	106	72	-0.320189E-01	106	73	-0.558140E-02
106	74	0.239599E-01	106	77	-0.335858E-01	106	78	0.279200E-03
106	79	0.336859E-01	106	82	-0.223499E-01	106	83	0.154700E-01
106	84	0.500414E-01	106	87	0.738500E-02	106	88	0.441374E-01
106	89	0.749212E-01	106	92	0.608566E-01	106	93	0.895500E-01
106	94	0.109394E 00	106	97	0.141772E 00	106	98	0.152819E 00
106	99	0.151946E 00	106	103	0.229167E 00	106	104	0.197442E 00
106	107	0.378327E 00	106	108	0.300837E 00	106	109	0.237993E 00
106	112	0.443063E 00	106	113	0.348599E 00	106	114	0.265284E 00
106	117	0.454504E 00	106	118	0.360305E 00	106	119	0.274132E 00
107	2	0.424943E 00	107	3	0.360603E 00	107	4	0.301240E 00
107	7	0.360878E 00	107	8	0.315444E 00	107	9	0.272499E 00
107	12	0.272777E 00	107	13	0.253763E 00	107	14	0.233346E 00
107	17	0.176979E 00	107	18	0.185741E 00	107	19	0.189531E 00
107	23	0.122047E 00	107	24	0.146755E 00	107	27	0.246275E-01
107	28	0.700548E-01	107	29	0.109696E 00	107	32	-0.177704E-01
107	33	0.334888E-01	107	34	0.811409E-01	107	37	-0.395266E-01
107	38	0.118177E-01	107	39	0.620493E-01	107	42	-0.451934E-01
107	43	0.301290E-02	107	44	0.518505E-01	107	47	-0.386755E-01
107	48	0.410110E-02	107	49	0.490126E-01	107	52	-0.244278E-01
107	53	0.118137E-01	107	54	0.517688E-01	107	57	-0.743640E-02
107	58	0.231507E-01	107	59	0.583729E-01	107	63	0.359030E-01

107	64	0.675105E-01	107	67	0.241612E-01	107	68	0.490215E-01
107	69	0.784737E-01	107	72	0.371847E-01	107	73	0.625031E-01
107	74	0.912540E-01	107	77	0.499200E-01	107	78	0.775227E-01
107	79	0.106499E 00	107	82	0.665210E-01	107	83	0.964018E-01
107	84	0.125418E 00	107	87	0.907240E-01	107	88	0.122181E 00
107	89	0.149570E 00	107	92	0.126543E 00	107	93	0.158348E 00
107	94	0.180189E 00	107	97	0.182262E 00	107	98	0.208423E 00
107	99	0.217100E 00	107	103	0.275521E 00	107	104	0.255762E 00
107	107	0.378330E 00	107	108	0.342732E 00	107	109	0.288528E 00
107	112	0.443568E 00	107	113	0.375621E 00	107	114	0.311050E 00
107	117	0.451387E 00	107	118	0.382078E 00	107	119	0.315043E 00
108	2	0.402816E 00	108	3	0.363887E 00	108	4	0.328776E 00
108	7	0.350666E 00	108	8	0.323427E 00	108	9	0.300001E 00
108	12	0.273075E 00	108	13	0.267812E 00	108	14	0.262722E 00
108	17	0.186066E 00	108	18	0.205702E 00	108	19	0.221687E 00
108	23	0.147718E 00	108	24	0.181941E 00	108	27	0.494348E-01
108	28	0.100913E 00	108	29	0.147781E 00	108	32	0.132339E-01
108	33	0.685785E-01	108	34	0.121674E 00	108	37	-0.525660E-02
108	38	0.494797E-01	108	39	0.104421E 00	108	42	-0.105837E-01
108	43	0.416343E-01	108	44	0.954762E-01	108	47	-0.570270E-02
108	48	0.427103E-01	108	49	0.936868E-01	108	52	0.635950E-02
108	53	0.505297E-01	108	54	0.978290E-01	108	57	0.231758E-01
108	58	0.634401E-01	108	59	0.106752E 00	108	63	0.806147E-01
108	64	0.119425E 00	108	67	0.700026E-01	108	68	0.100806E 00
108	69	0.134936E 00	108	72	0.962633E-01	108	73	0.122512E 00
108	74	0.152425E 00	108	77	0.119770E 00	108	78	0.144010E 00
108	79	0.171357E 00	108	82	0.140214E 00	108	83	0.165186E 00
108	84	0.191778E 00	108	87	0.158833E 00	108	88	0.187378E 00
108	89	0.214600E 00	108	92	0.178473E 00	108	93	0.214203E 00
108	94	0.241339E 00	108	97	0.209018E 00	108	98	0.248843E 00
108	99	0.274200E 00	108	103	0.311997E 00	108	104	0.309451E 00
108	107	0.348897E 00	108	108	0.358320E 00	108	109	0.343961E 00
108	112	0.399847E 00	108	113	0.392009E 00	108	114	0.350878E 00
108	117	0.420724E 00	108	118	0.382249E 00	108	119	0.346834E 00
109	2	0.365201E 00	109	3	0.353537E 00	109	4	0.348199E 00
109	7	0.326710E 00	109	8	0.321045E 00	109	9	0.321125E 00
109	12	0.263514E 00	109	13	0.274519E 00	109	14	0.287741E 00
109	17	0.190012E 00	109	18	0.221886E 00	109	19	0.251687E 00
109	23	0.173327E 00	109	24	0.217261E 00	109	27	0.789934E-01
109	28	0.135202E 00	109	29	0.188148E 00	109	32	0.530193E-01
109	33	0.109969E 00	109	34	0.166239E 00	109	37	0.405042E-01
109	38	0.953302E-01	109	39	0.151951E 00	109	42	0.365067E-01
109	43	0.891021E-01	109	44	0.144606E 00	109	47	0.388814E-01
109	48	0.894850E-01	109	49	0.143368E 00	109	52	0.460920E-01
109	53	0.954483E-01	109	54	0.147589E 00	109	57	0.585777E-01
109	58	0.106885E 00	109	59	0.156850E 00	109	63	0.124697E 00
109	64	0.170617E 00	109	67	0.109886E 00	109	68	0.147859E 00
109	69	0.188056E 00	109	72	0.143905E 00	109	73	0.173816E 00
109	74	0.207753E 00	109	77	0.173436E 00	109	78	0.198382E 00
109	79	0.228271E 00	109	82	0.194453E 00	109	83	0.219386E 00
109	84	0.248711E 00	109	87	0.206238E 00	109	88	0.236755E 00
109	89	0.269340E 00	109	92	0.210926E 00	109	93	0.253402E 00
109	94	0.291912E 00	109	97	0.218413E 00	109	98	0.274979E 00
109	99	0.319078E 00	109	103	0.307259E 00	109	104	0.361104E 00
109	107	0.289843E 00	109	108	0.348697E 00	109	109	0.365982E 00
109	112	0.343436E 00	109	113	0.364297E 00	109	114	0.389327E 00
109	117	0.371582E 00	109	118	0.368335E 00	109	119	0.367513E 00

110	2	0.315702E 00	110	3	0.330750E 00	110	4	0.357189E 00
110	7	0.291568E 00	110	8	0.308892E 00	110	9	0.335354E 00
110	12	0.245380E 00	110	13	0.274404E 00	110	14	0.308219E 00
110	17	0.189299E 00	110	18	0.234413E 00	110	19	0.279302E 00
110	23	0.198594E 00	110	24	0.252289E 00	110	27	0.112616E 00
110	28	0.172289E 00	110	29	0.230153E 00	110	32	0.100566E 00
110	33	0.156771E 00	110	34	0.214014E 00	110	37	0.965995E-01
110	38	0.148350E 00	110	39	0.203707E 00	110	42	0.949829E-01
110	43	0.144412E 00	110	44	0.198292E 00	110	47	0.941360E-01
110	48	0.143495E 00	110	49	0.197121E 00	110	52	0.940419E-01
110	53	0.145753E 00	110	54	0.200151E 00	110	57	0.982293E-01
110	58	0.152771E 00	110	59	0.207806E 00	110	63	0.167484E 00
110	64	0.220238E 00	110	67	0.143328E 00	110	68	0.189466E 00
110	69	0.236941E 00	110	72	0.179455E 00	110	73	0.215548E 00
110	74	0.256219E 00	110	77	0.210012E 00	110	78	0.239499E 00
110	79	0.275982E 00	110	82	0.228005E 00	110	83	0.257406E 00
110	84	0.294457E 00	110	87	0.231665E 00	110	88	0.267988E 00
110	89	0.311202E 00	110	92	0.222976E 00	110	93	0.273304E 00
110	94	0.327132E 00	110	97	0.212319E 00	110	98	0.277810E 00
110	99	0.343848E 00	110	103	0.288741E 00	110	104	0.359690E 00
110	107	0.246658E 00	110	108	0.304759E 00	110	109	0.378247E 00
110	112	0.285849E 00	110	113	0.325944E 00	110	114	0.376495E 00
110	117	0.313313E 00	110	118	0.336122E 00	110	119	0.371656E 00
111	2	0.739371E 00	111	3	0.575893E 00	111	4	0.427244E 00
111	7	0.626759E 00	111	8	0.506257E 00	111	9	0.390787E 00
111	12	0.466783E 00	111	13	0.400676E 00	111	14	0.329824E 00
111	17	0.292862E 00	111	18	0.280768E 00	111	19	0.256741E 00
111	23	0.167029E 00	111	24	0.183198E 00	111	27	0.151178E-01
111	28	0.736150E-01	111	29	0.118432E 00	111	32	-0.619826E-01
111	33	0.782240E-02	111	34	0.678884E-01	111	37	-0.999514E-01
111	38	-0.309340E-01	111	39	0.332665E-01	111	42	-0.108347E 00
111	43	-0.472430E-01	111	44	0.130105E-01	111	47	-0.964544E-01
111	48	-0.480007E-01	111	49	0.353020E-02	111	52	-0.753106E-01
111	53	-0.413887E-01	111	54	0.467300E-03	111	57	-0.585661E-01
111	58	-0.351818E-01	111	59	-0.280300E-03	111	63	-0.353013E-01
111	64	-0.127030E-02	111	67	-0.712199E-01	111	68	-0.425881E-01
111	69	-0.290030E-02	111	72	-0.973657E-01	111	73	-0.534417E-01
111	74	-0.299590E-02	111	77	-0.121182E 00	111	78	-0.595482E-01
111	79	0.253740E-02	111	82	-0.125503E 00	111	83	-0.510489E-01
111	84	0.189507E-01	111	87	-0.979083E-01	111	88	-0.187073E-01
111	89	0.510411E-01	111	92	-0.283259E-01	111	93	0.446539E-01
111	94	0.101987E 00	111	97	0.930243E-01	111	98	0.142915E 00
111	99	0.171364E 00	111	103	0.274506E 00	111	104	0.252467E 00
111	107	0.502406E 00	111	108	0.415685E 00	111	109	0.332829E 00
111	112	0.699222E 00	111	113	0.530485E 00	111	114	0.396556E 00
111	117	0.776076E 00	111	118	0.588215E 00	111	119	0.429994E 00
112	2	0.639498E 00	112	3	0.523257E 00	112	4	0.413275E 00
112	7	0.553090E 00	112	8	0.464006E 00	112	9	0.379819E 00
112	12	0.420368E 00	112	13	0.374985E 00	112	14	0.326418E 00
112	17	0.273039E 00	112	18	0.272849E 00	112	19	0.263150E 00
112	23	0.175878E 00	112	24	0.199671E 00	112	27	0.379661E-01
112	28	0.964643E-01	112	29	0.143870E 00	112	32	-0.260835E-01
112	33	0.408285E-01	112	34	0.100353E 00	112	37	-0.579366E-01
112	38	0.783380E-02	112	39	0.705546E-01	112	42	-0.658920E-01
112	43	-0.641960E-02	112	44	0.532008E-01	112	47	-0.572425E-01
112	48	-0.742480E-02	112	49	0.454715E-01	112	52	-0.402861E-01
112	53	-0.132380E-02	112	54	0.440599E-01	112	57	-0.246939E-01

112	58	0.627340E-02	112	59	0.458903E-01	112	63	0.113546E-01
112	64	0.489403E-01	112	67	-0.182650E-01	112	68	0.129407E-01
112	69	0.526258E-01	112	72	-0.267030E-01	112	73	0.127599E-01
112	74	0.580165E-01	112	77	-0.349178E-01	112	78	0.154194E-01
112	79	0.675424E-01	112	82	-0.320239E-01	112	83	0.272220E-01
112	84	0.846207E-01	112	87	-0.952020E-02	112	88	0.546271E-01
112	89	0.112683E 00	112	92	0.403331E-01	112	93	0.103605E 00
112	94	0.154443E 00	112	97	0.127549E 00	112	98	0.178467E 00
112	99	0.210392E 00	112	103	0.281231E 00	112	104	0.276267E 00
112	107	0.444121E 00	112	108	0.397952E 00	112	109	0.341872E 00
112	112	0.606057E 00	112	113	0.500467E 00	112	114	0.391878E 00
112	117	0.670769E 00	112	118	0.537856E 00	112	119	0.418766E 00
113	2	0.546657E 00	113	3	0.474156E 00	113	4	0.408295E 00
113	7	0.480807E 00	113	8	0.426220E 00	113	9	0.375286E 00
113	12	0.375281E 00	113	13	0.352464E 00	113	14	0.328404E 00
113	17	0.254218E 00	113	18	0.267813E 00	113	19	0.274311E 00
113	23	0.187709E 00	113	24	0.220648E 00	113	27	0.631872E-01
113	28	0.122735E 00	113	29	0.173814E 00	113	32	0.132419E-01
113	33	0.778153E-01	113	34	0.137440E 00	113	37	-0.115493E-01
113	38	0.510665E-01	113	39	0.112566E 00	113	42	-0.185780E-01
113	43	0.390723E-01	113	44	0.980774E-01	113	47	-0.132603E-01
113	48	0.376430E-01	113	49	0.918603E-01	113	52	-0.127450E-02
113	53	0.426010E-01	113	54	0.916197E-01	113	57	0.117293E-01
113	58	0.505292E-01	113	59	0.953287E-01	113	63	0.594553E-01
113	64	0.101572E 00	113	67	0.332767E-01	113	68	0.684375E-01
113	69	0.109695E 00	113	72	0.404909E-01	113	73	0.775371E-01
113	74	0.119803E 00	113	77	0.461070E-01	113	78	0.878649E-01
113	79	0.132816E 00	113	82	0.551034E-01	113	83	0.102393E 00
113	84	0.150465E 00	113	87	0.724450E-01	113	88	0.125068E 00
113	89	0.174965E 00	113	92	0.103730E 00	113	93	0.160713E 00
113	94	0.208678E 00	113	97	0.159181E 00	113	98	0.214374E 00
113	99	0.253026E 00	113	103	0.289551E 00	113	104	0.306989E 00
113	107	0.377718E 00	113	108	0.392002E 00	113	109	0.362258E 00
113	112	0.506545E 00	113	113	0.464726E 00	113	114	0.409866E 00
113	117	0.557446E 00	113	118	0.500766E 00	113	119	0.419839E 00
114	2	0.448496E 00	114	3	0.422340E 00	114	4	0.401482E 00
114	7	0.405176E 00	114	8	0.385241E 00	114	9	0.371354E 00
114	12	0.326976E 00	114	13	0.328740E 00	114	14	0.331817E 00
114	17	0.234001E 00	114	18	0.262995E 00	114	19	0.287777E 00
114	23	0.201500E 00	114	24	0.244828E 00	114	27	0.919141E-01
114	28	0.152745E 00	114	29	0.207873E 00	114	32	0.584811E-01
114	33	0.120127E 00	114	34	0.179431E 00	114	37	0.425552E-01
114	38	0.100745E 00	114	39	0.159988E 00	114	42	0.372432E-01
114	43	0.914350E-01	114	44	0.148459E 00	114	47	0.388270E-01
114	48	0.891674E-01	114	49	0.143342E 00	114	52	0.442002E-01
114	53	0.917117E-01	114	54	0.143354E 00	114	57	0.518817E-01
114	58	0.979412E-01	114	59	0.147585E 00	114	63	0.108157E 00
114	64	0.155366E 00	114	67	0.812476E-01	114	68	0.121747E 00
114	69	0.166161E 00	114	72	0.100335E 00	114	73	0.137431E 00
114	74	0.179331E 00	114	77	0.116486E 00	114	78	0.153144E 00
114	79	0.194503E 00	114	82	0.129357E 00	114	83	0.168841E 00
114	84	0.211879E 00	114	87	0.140883E 00	114	88	0.186207E 00
114	89	0.232601E 00	114	92	0.154822E 00	114	93	0.208932E 00
114	94	0.258561E 00	114	97	0.181157E 00	114	98	0.241853E 00
114	99	0.291948E 00	114	103	0.291961E 00	114	104	0.333223E 00
114	107	0.312971E 00	114	108	0.352944E 00	114	109	0.389353E 00
114	112	0.392893E 00	114	113	0.414622E 00	114	114	0.403504E 00

114	117	0.445932E	00	114	118	0.431520E	00	114	119	0.428936E	00
115	2	0.353090E	00	115	3	0.362543E	00	115	4	0.386803E	00
115	7	0.328468E	00	115	8	0.341286E	00	115	9	0.365044E	00
115	12	0.276841E	00	115	13	0.303516E	00	115	14	0.335509E	00
115	17	0.212759E	00	115	18	0.258183E	00	115	19	0.302818E	00
115	23	0.216826E	00	115	24	0.271559E	00	115	27	0.123584E	00
115	28	0.185890E	00	115	29	0.245344E	00	115	32	0.108908E	00
115	33	0.167045E	00	115	34	0.225556E	00	115	37	0.103657E	00
115	38	0.156124E	00	115	39	0.212007E	00	115	42	0.100963E	00
115	43	0.149950E	00	115	44	0.203496E	00	115	47	0.985525E-01	
115	48	0.146490E	00	115	49	0.199069E	00	115	52	0.957704E-01	
115	53	0.145375E	00	115	54	0.198394E	00	115	57	0.953687E-01	
115	58	0.147821E	00	115	59	0.201728E	00	115	63	0.156602E	00
115	64	0.209269E	00	115	67	0.124640E	00	115	68	0.171720E	00
115	69	0.220793E	00	115	72	0.151258E	00	115	73	0.190903E	00
115	74	0.235140E	00	115	77	0.174013E	00	115	78	0.209282E	00
115	79	0.250884E	00	115	82	0.187992E	00	115	83	0.224205E	00
115	84	0.266925E	00	115	87	0.192685E	00	115	88	0.235329E	00
115	89	0.283300E	00	115	92	0.190635E	00	115	93	0.245152E	00
115	94	0.301238E	00	115	97	0.191673E	00	115	98	0.258219E	00
115	99	0.322511E	00	115	103	0.280875E	00	115	104	0.347453E	00
115	107	0.254964E	00	115	108	0.311364E	00	115	109	0.372121E	00
115	112	0.308350E	00	115	113	0.341215E	00	115	114	0.396512E	00
115	117	0.345493E	00	115	118	0.362457E	00	115	119	0.395770E	00
116	2	0.986329E	00	116	3	0.746353E	00	116	4	0.541423E	00
116	7	0.856604E	00	116	8	0.674260E	00	116	9	0.505730E	00
116	12	0.646259E	00	116	13	0.541586E	00	116	14	0.432641E	00
116	17	0.409749E	00	116	18	0.382260E	00	116	19	0.338710E	00
116	23	0.227592E	00	116	24	0.241015E	00	116	27	0.248453E-01	
116	28	0.989510E-01		116	29	0.153443E	00	116	32	-0.831372E-01	
116	33	0.768230E-02		116	34	0.843709E-01		116	37	-0.137420E	00
116	38	-0.466140E-01		116	39	0.367546E-01		116	42	-0.150680E	00
116	43	-0.699686E-01		116	44	0.869670E-02		116	47	-0.134937E	00
116	48	-0.712606E-01		116	49	-0.428750E-02		116	52	-0.105279E	00
116	53	-0.617041E-01		116	54	-0.820730E-02		116	57	-0.804936E-01	
116	58	-0.520241E-01		116	59	-0.877100E-02		116	63	-0.505878E-01	
116	64	-0.977960E-02		116	67	-0.918600E-01		116	68	-0.593198E-01	
116	69	-0.122791E-01		116	72	-0.125764E	00	116	73	-0.743832E-01	
116	74	-0.139781E-01		116	77	-0.159876E	00	116	78	-0.857729E-01	
116	79	-0.999240E-02		116	82	-0.172734E	00	116	83	-0.810313E-01	
116	84	0.640120E-02		116	87	-0.149099E	00	116	88	-0.488439E-01	
116	89	0.410894E-01		116	92	-0.757179E-01		116	93	0.204523E-01	
116	94	0.988082E-01		116	97	0.600398E-01		116	98	0.132424E	00
116	99	0.180230E	00	116	103	0.286255E	00	116	104	0.279594E	00
116	107	0.528997E	00	116	108	0.462911E	00	116	109	0.383822E	00
116	112	0.797271E	00	116	113	0.626538E	00	116	114	0.473704E	00
116	117	0.980060E	00	116	118	0.729593E	00	116	119	0.530701E	00
117	2	0.825500E	00	117	3	0.652828E	00	117	4	0.498269E	00
117	7	0.718337E	00	117	8	0.589872E	00	117	9	0.466590E	00
117	12	0.553435E	00	117	13	0.480637E	00	117	14	0.404612E	00
117	17	0.361402E	00	117	18	0.350510E	00	117	19	0.326382E	00
117	23	0.224406E	00	117	24	0.245623E	00	117	27	0.509418E-01	
117	28	0.120054E	00	117	29	0.173464E	00	117	32	-0.342952E-01	
117	33	0.464740E-01		117	34	0.116535E	00	117	37	-0.772728E-01	
117	38	0.236500E-02		117	39	0.770743E-01		117	42	-0.888010E-01	
117	43	-0.173333E-01		117	44	0.535118E-01		117	47	-0.784844E-01	
117	48	-0.198385E-01		117	49	0.421851E-01		117	52	-0.574772E-01	

117	53	-0.134465E-01	117	54	0.386293E-01	117	57	-0.391323E-01
117	58	-0.585280E-02	117	59	0.386547E-01	117	63	-0.270680E-02
117	64	0.394591E-01	117	67	-0.400555E-01	117	68	-0.549080E-02
117	69	0.401758E-01	117	72	-0.584641E-01	117	73	-0.119205E-01
117	74	0.422019E-01	117	77	-0.776870E-01	117	78	-0.156970E-01
117	79	0.487916E-01	117	82	-0.831897E-01	117	83	-0.835640E-02
117	84	0.645460E-01	117	87	-0.636967E-01	117	88	0.185569E-01
117	89	0.939881E-01	117	92	-0.912820E-02	117	93	0.726461E-01
117	94	0.140821E 00	117	97	0.920613E-01	117	98	0.159136E 00
117	99	0.206073E 00	117	103	0.279310E 00	117	104	0.285919E 00
117	107	0.452020E 00	117	108	0.420224E 00	117	109	0.370697E 00
117	112	0.671240E 00	117	113	0.555945E 00	117	114	0.444500E 00
117	117	0.818548E 00	117	118	0.648959E 00	117	119	0.489338E 00
118	2	0.660106E 00	118	3	0.575497E 00	118	4	0.469825E 00
118	7	0.590324E 00	118	8	0.511678E 00	118	9	0.438625E 00
118	12	0.464556E 00	118	13	0.426317E 00	118	14	0.384841E 00
118	17	0.316097E 00	118	18	0.323480E 00	118	19	0.320838E 00
118	23	0.224964E 00	118	24	0.255903E 00	118	27	0.784070E-01
118	28	0.144314E 00	118	29	0.198429E 00	118	32	0.159738E-01
118	33	0.882085E-01	118	34	0.153196E 00	118	37	-0.153207E-01
118	38	0.543078E-01	118	39	0.121635E 00	118	42	-0.248785E-01
118	43	0.382363E-01	118	44	0.102317E 00	118	47	-0.197576E-01
118	48	0.345262E-01	118	49	0.924753E-01	118	52	-0.749800E-02
118	53	0.375792E-01	118	54	0.890559E-01	118	57	0.390030E-02
118	58	0.426792E-01	118	59	0.893593E-01	118	63	0.469359E-01
118	64	0.915927E-01	118	67	0.115718E-01	118	68	0.493837E-01
118	69	0.951167E-01	118	72	0.753990E-02	118	73	0.508601E-01
118	74	0.100507E 00	118	77	0.212020E-02	118	78	0.540775E-01
118	79	0.109483E 00	118	82	0.336770E-02	118	83	0.638097E-01
118	84	0.124738E 00	118	87	0.185531E-01	118	88	0.855864E-01
118	89	0.149334E 00	118	92	0.549505E-01	118	93	0.125232E 00
118	94	0.186142E 00	118	97	0.123191E 00	118	98	0.187674E 00
118	99	0.236634E 00	118	103	0.276597E 00	118	104	0.298906E 00
118	107	0.383155E 00	118	108	0.382290E 00	118	109	0.367663E 00
118	112	0.539794E 00	118	113	0.500878E 00	118	114	0.429542E 00
118	117	0.654865E 00	118	118	0.565877E 00	118	119	0.473459E 00
119	2	0.508787E 00	119	3	0.475590E 00	119	4	0.456733E 00
119	7	0.467554E 00	119	8	0.439365E 00	119	9	0.415544E 00
119	12	0.380613E 00	119	13	0.375801E 00	119	14	0.371379E 00
119	17	0.273341E 00	119	18	0.300365E 00	119	19	0.321186E 00
119	23	0.228868E 00	119	24	0.271611E 00	119	27	0.107275E 00
119	28	0.171723E 00	119	29	0.228405E 00	119	32	0.680398E-01
119	33	0.133165E 00	119	34	0.194607E 00	119	37	0.491290E-01
119	38	0.109716E 00	119	39	0.170789E 00	119	42	0.421629E-01
119	43	0.974876E-01	119	44	0.155579E 00	119	47	0.423461E-01
119	48	0.925683E-01	119	49	0.147000E 00	119	52	0.455588E-01
119	53	0.919307E-01	119	54	0.143340E 00	119	57	0.490682E-01
119	58	0.937917E-01	119	59	0.143368E 00	119	63	0.980912E-01
119	64	0.146330E 00	119	67	0.621132E-01	119	68	0.104501E 00
119	69	0.151892E 00	119	72	0.705332E-01	119	73	0.112572E 00
119	74	0.159916E 00	119	77	0.770581E-01	119	78	0.121613E 00
119	79	0.170726E 00	119	82	0.836895E-01	119	83	0.132953E 00
119	84	0.185246E 00	119	87	0.940850E-01	119	88	0.149433E 00
119	89	0.205193E 00	119	92	0.113062E 00	119	93	0.175221E 00
119	94	0.232660E 00	119	97	0.150462E 00	119	98	0.215034E 00
119	99	0.269422E 00	119	103	0.273891E 00	119	104	0.315312E 00
119	107	0.316494E 00	119	108	0.347651E 00	119	109	0.367563E 00

119	112	0.420437E	00	119	113	0.421931E	00	119	114	0.428957E	00
119	117	0.490159E	00	119	118	0.478147E	00	119	119	0.440861E	00
120	2	0.378183E	00	120	3	0.384004E	00	120	4	0.408022E	00
120	7	0.355512E	00	120	8	0.365993E	00	120	9	0.390453E	00
120	12	0.301817E	00	120	13	0.327905E	00	120	14	0.360447E	00
120	17	0.233160E	00	120	18	0.279856E	00	120	19	0.325648E	00
120	23	0.235280E	00	120	24	0.291600E	00	120	27	0.137065E	00
120	28	0.201596E	00	120	29	0.262533E	00	120	32	0.121501E	00
120	33	0.180784E	00	120	34	0.240037E	00	120	37	0.115827E	00
120	38	0.168139E	00	120	39	0.223870E	00	120	42	0.112173E	00
120	43	0.160006E	00	120	44	0.212611E	00	120	47	0.107765E	00
120	48	0.153900E	00	120	49	0.205051E	00	120	52	0.101613E	00
120	53	0.149164E	00	120	54	0.200700E	00	120	57	0.961178E	-01
120	58	0.146879E	00	120	59	0.199765E	00	120	63	0.149875E	00
120	64	0.202559E	00	120	67	0.110441E	00	120	68	0.158597E	00
120	69	0.209141E	00	120	72	0.128759E	00	120	73	0.171512E	00
120	74	0.218799E	00	120	77	0.144733E	00	120	78	0.184765E	00
120	79	0.230623E	00	120	82	0.154933E	00	120	83	0.196616E	00
120	84	0.243991E	00	120	87	0.159769E	00	120	88	0.207375E	00
120	89	0.259278E	00	120	92	0.162166E	00	120	93	0.219763E	00
120	94	0.277829E	00	120	97	0.171439E	00	120	98	0.238162E	00
120	99	0.301386E	00	120	103	0.268445E	00	120	104	0.330324E	00
120	107	0.255729E	00	120	108	0.308288E	00	120	109	0.362736E	00
120	112	0.318811E	00	120	113	0.349339E	00	120	114	0.391366E	00
120	117	0.365282E	00	120	118	0.375898E	00	120	119	0.414732E	00

LISTING OF THE FLEXIBILITY MATRIX
OF THE PERKIN-ELMER MIRROR

1	2	0.107266E 01	1	3	0.799636E 00	1	4	0.584928E 00
1	7	0.920932E 00	1	8	0.719361E 00	1	9	0.543192E 00
1	12	0.677430E 00	1	13	0.580111E 00	1	14	0.473061E 00
1	17	0.427998E 00	1	18	0.425281E 00	1	19	0.387111E 00
1	23	0.284368E 00	1	24	0.299580E 00	1	27	0.106341E 00
1	28	0.170763E 00	1	29	0.221113E 00	1	32	0.726290E-02
1	33	0.864217E-01	1	34	0.156899E 00	1	37	-0.579078E-01
1	38	0.268961E-01	1	39	0.108347E 00	1	42	-0.932715E-01
1	43	-0.941890E-02	1	44	0.749686E-01	1	47	-0.109354E 00
1	48	-0.311298E-01	1	49	0.517473E-01	1	52	-0.110796E 00
1	53	-0.425200E-01	1	54	0.368710E-01	1	57	-0.112066E 00
1	58	-0.508742E-01	1	59	0.280908E-01	1	63	-0.581646E-01
1	64	0.245805E-01	1	67	-0.145783E 00	1	68	-0.627563E-01
1	69	0.273116E-01	1	72	-0.150078E 00	1	73	-0.572214E-01
1	74	0.386942E-01	1	77	-0.132256E 00	1	78	-0.344763E-01
1	79	0.620751E-01	1	82	-0.846356E-01	1	83	0.957600E-02
1	84	0.990010E-01	1	87	-0.387400E-03	1	88	0.811428E-01
1	89	0.154036E 00	1	92	0.120308E 00	1	93	0.181703E 00
1	94	0.225383E 00	1	97	0.284515E 00	1	98	0.309550E 00
1	99	0.309817E 00	1	103	0.456667E 00	1	104	0.400006E 00
1	107	0.724438E 00	1	108	0.606206E 00	1	109	0.484796E 00
1	112	0.920025E 00	1	113	0.730940E 00	1	114	0.551130E 00
1	117	0.105250E 01	1	118	0.803039E 00	1	119	0.586194E 00
2	2	0.914867E 00	2	3	0.726832E 00	2	4	0.546660E 00
2	7	0.797007E 00	2	8	0.650260E 00	2	9	0.514119E 00
2	12	0.592037E 00	2	13	0.532163E 00	2	14	0.455307E 00
2	17	0.393520E 00	2	18	0.404731E 00	2	19	0.383616E 00
2	23	0.291061E 00	2	24	0.311213E 00	2	27	0.142126E 00
2	28	0.199998E 00	2	29	0.246523E 00	2	32	0.643944E-01
2	33	0.132020E 00	2	34	0.193292E 00	2	37	0.112466E-01
2	38	0.826873E-01	2	39	0.152366E 00	2	42	-0.204174E-01
2	43	0.508913E-01	2	44	0.123458E 00	2	47	-0.390803E-01
2	48	0.295036E-01	2	49	0.102283E 00	2	52	-0.469420E-01
2	53	0.163663E-01	2	54	0.880132E-01	2	57	-0.531046E-01
2	58	0.676800E-02	2	59	0.792261E-01	2	63	-0.156300E-03
2	64	0.755141E-01	2	67	-0.785506E-01	2	68	-0.328250E-02
2	69	0.776787E-01	2	72	-0.791999E-01	2	73	0.267090E-02
2	74	0.874864E-01	2	77	-0.624296E-01	2	78	0.226021E-01
2	79	0.107398E 00	2	82	-0.225200E-01	2	83	0.595632E-01
2	84	0.138531E 00	2	87	0.453412E-01	2	88	0.118093E 00
2	89	0.184349E 00	2	92	0.141428E 00	2	93	0.200028E 00
2	94	0.243600E 00	2	97	0.273392E 00	2	98	0.304639E 00
2	99	0.313817E 00	2	103	0.425850E 00	2	104	0.389162E 00
2	107	0.634792E 00	2	108	0.549657E 00	2	109	0.460649E 00
2	112	0.791606E 00	2	113	0.654587E 00	2	114	0.517502E 00
2	117	0.905541E 00	2	118	0.718560E 00	2	119	0.548540E 00
3	2	0.733153E 00	3	3	0.633453E 00	3	4	0.527342E 00
3	7	0.640583E 00	3	8	0.585456E 00	3	9	0.492889E 00
3	12	0.500397E 00	3	13	0.479377E 00	3	14	0.443657E 00
3	17	0.354394E 00	3	18	0.384390E 00	3	19	0.385091E 00
3	23	0.300400E 00	3	24	0.328520E 00	3	27	0.181858E 00
3	28	0.234282E 00	3	29	0.278585E 00	3	32	0.128060E 00
3	33	0.184484E 00	3	34	0.237297E 00	3	37	0.886565E-01
3	38	0.146643E 00	3	39	0.204766E 00	3	42	0.617763E-01
3	43	0.120315E 00	3	44	0.181043E 00	3	47	0.407719E-01
3	48	0.996339E-01	3	49	0.162293E 00	3	52	0.262389E-01
3	53	0.849160E-01	3	54	0.148889E 00	3	57	0.150778E-01

3	58	0.742919E-01	3	59	0.140298E 00	3	63	0.681109E-01
3	64	0.136551E 00	3	67	-0.187200E-03	3	68	0.668701E-01
3	69	0.138228E 00	3	72	0.338740E-02	3	73	0.733930E-01
3	74	0.146361E 00	3	77	0.188301E-01	3	78	0.901087E-01
3	79	0.162414E 00	3	82	0.495909E-01	3	83	0.118817E 00
3	84	0.186946E 00	3	87	0.985150E-01	3	88	0.162433E 00
3	89	0.222397E 00	3	92	0.166431E 00	3	93	0.223209E 00
3	94	0.268120E 00	3	97	0.261758E 00	3	98	0.301592E 00
3	99	0.322580E 00	3	103	0.393685E 00	3	104	0.381752E 00
3	107	0.533798E 00	3	108	0.489114E 00	3	109	0.439232E 00
3	112	0.651276E 00	3	113	0.569775E 00	3	114	0.488135E 00
3	117	0.722581E 00	3	118	0.636140E 00	3	119	0.517654E 00
4	2	0.547042E 00	4	3	0.532068E 00	4	4	0.485113E 00
4	7	0.496698E 00	4	8	0.487344E 00	4	9	0.486589E 00
4	12	0.408418E 00	4	13	0.426824E 00	4	14	0.434335E 00
4	17	0.315120E 00	4	18	0.362787E 00	4	19	0.389130E 00
4	23	0.308674E 00	4	24	0.347808E 00	4	27	0.217568E 00
4	28	0.266938E 00	4	29	0.312149E 00	4	32	0.187367E 00
4	33	0.235158E 00	4	34	0.282463E 00	4	37	0.162085E 00
4	38	0.209025E 00	4	39	0.258236E 00	4	42	0.140575E 00
4	43	0.188406E 00	4	44	0.239538E 00	4	47	0.118416E 00
4	48	0.169163E 00	4	49	0.223496E 00	4	52	0.984733E-01
4	53	0.153674E 00	4	54	0.211333E 00	4	57	0.834027E-01
4	58	0.142751E 00	4	59	0.203330E 00	4	63	0.137869E 00
4	64	0.199889E 00	4	67	0.794625E-01	4	68	0.138842E 00
4	69	0.201338E 00	4	72	0.872926E-01	4	73	0.146040E 00
4	74	0.207968E 00	4	77	0.101145E 00	4	78	0.159477E 00
4	79	0.220277E 00	4	82	0.122609E 00	4	83	0.180017E 00
4	84	0.238517E 00	4	87	0.152330E 00	4	88	0.208665E 00
4	89	0.263798E 00	4	92	0.192079E 00	4	93	0.248361E 00
4	94	0.296278E 00	4	97	0.251205E 00	4	98	0.300746E 00
4	99	0.335357E 00	4	103	0.364123E 00	4	104	0.378708E 00
4	107	0.437135E 00	4	108	0.430604E 00	4	109	0.422466E 00
4	112	0.514346E 00	4	113	0.487871E 00	4	114	0.462700E 00
4	117	0.554866E 00	4	118	0.522284E 00	4	119	0.502648E 00
5	2	0.403420E 00	5	3	0.411172E 00	5	4	0.451832E 00
5	7	0.371732E 00	5	8	0.394688E 00	5	9	0.431659E 00
5	12	0.322269E 00	5	13	0.365643E 00	5	14	0.411871E 00
5	17	0.273825E 00	5	18	0.335465E 00	5	19	0.387326E 00
5	23	0.311256E 00	5	24	0.363851E 00	5	27	0.245568E 00
5	28	0.294019E 00	5	29	0.343263E 00	5	32	0.238856E 00
5	33	0.280611E 00	5	34	0.325534E 00	5	37	0.228599E 00
5	38	0.266944E 00	5	39	0.309980E 00	5	42	0.214081E 00
5	43	0.253168E 00	5	44	0.296868E 00	5	47	0.192696E 00
5	48	0.236679E 00	5	49	0.284217E 00	5	52	0.169277E 00
5	53	0.221765E 00	5	54	0.274037E 00	5	57	0.152001E 00
5	58	0.211753E 00	5	59	0.267340E 00	5	63	0.209144E 00
5	64	0.264828E 00	5	67	0.161573E 00	5	68	0.212990E 00
5	69	0.266520E 00	5	72	0.173965E 00	5	73	0.221162E 00
5	74	0.271943E 00	5	77	0.185999E 00	5	78	0.231273E 00
5	79	0.280636E 00	5	82	0.197353E 00	5	83	0.243168E 00
5	84	0.292471E 00	5	87	0.207021E 00	5	88	0.256297E 00
5	89	0.307420E 00	5	92	0.217858E 00	5	93	0.274268E 00
5	94	0.326364E 00	5	97	0.240467E 00	5	98	0.299984E 00
5	99	0.349496E 00	5	103	0.333798E 00	5	104	0.375765E 00
5	107	0.343530E 00	5	108	0.370236E 00	5	109	0.402513E 00
5	112	0.386504E 00	5	113	0.399904E 00	5	114	0.425913E 00

5	117	0.407306E 00	5	118	0.414926E 00	5	119	0.439848E 00
6	2	0.910141E 00	6	3	0.697301E 00	6	4	0.514680E 00
6	7	0.871386E 00	6	8	0.657718E 00	6	9	0.495103E 00
6	12	0.687388E 00	6	13	0.564122E 00	6	14	0.447851E 00
6	17	0.465850E 00	6	18	0.441211E 00	6	19	0.383300E 00
6	23	0.321108E 00	6	24	0.312437E 00	6	27	0.184660E 00
6	28	0.221485E 00	6	29	0.245147E 00	6	32	0.930599E-01
6	33	0.144143E 00	6	34	0.187167E 00	6	37	0.262003E-01
6	38	0.850276E-01	6	39	0.140445E 00	6	42	-0.181698E-01
6	43	0.436807E-01	6	44	0.105422E 00	6	47	-0.481101E-01
6	48	0.132133E-01	6	49	0.778227E-01	6	52	-0.658900E-01
6	53	-0.871160E-02	6	54	0.570759E-01	6	57	-0.821767E-01
6	58	-0.271627E-01	6	59	0.417932E-01	6	63	-0.432234E-01
6	64	0.316806E-01	6	67	-0.132779E 00	6	68	-0.553552E-01
6	69	0.277778E-01	6	72	-0.144033E 00	6	73	-0.572963E-01
6	74	0.321458E-01	6	77	-0.134845E 00	6	78	-0.433985E-01
6	79	0.475532E-01	6	82	-0.990897E-01	6	83	-0.103406E-01
6	84	0.752501E-01	6	87	-0.317339E-01	6	88	0.464922E-01
6	89	0.118767E 00	6	92	0.669814E-01	6	93	0.128072E 00
6	94	0.176646E 00	6	97	0.201268E 00	6	98	0.232484E 00
6	99	0.246476E 00	6	103	0.353808E 00	6	104	0.322799E 00
6	107	0.558399E 00	6	108	0.479697E 00	6	109	0.397404E 00
6	112	0.723903E 00	6	113	0.590904E 00	6	114	0.460623E 00
6	117	0.848723E 00	6	118	0.669274E 00	6	119	0.502002E 00
7	2	0.796862E 00	7	3	0.638727E 00	7	4	0.495471E 00
7	7	0.757089E 00	7	8	0.617065E 00	7	9	0.478705E 00
7	12	0.612188E 00	7	13	0.529746E 00	7	14	0.441886E 00
7	17	0.426154E 00	7	18	0.425696E 00	7	19	0.387894E 00
7	23	0.327721E 00	7	24	0.328656E 00	7	27	0.212299E 00
7	28	0.248080E 00	7	29	0.272634E 00	7	32	0.141386E 00
7	33	0.185763E 00	7	34	0.224087E 00	7	37	0.869411E-01
7	38	0.136428E 00	7	39	0.184133E 00	7	42	0.473153E-01
7	43	0.998732E-01	7	44	0.153266E 00	7	47	0.158788E-01
7	48	0.701286E-01	7	49	0.127569E 00	7	52	-0.733820E-02
7	53	0.468295E-01	7	54	0.107380E 00	7	57	-0.280841E-01
7	58	0.272435E-01	7	59	0.920606E-01	7	63	0.114121E-01
7	64	0.817462E-01	7	67	-0.717058E-01	7	68	0.556200E-03
7	69	0.774133E-01	7	72	-0.796342E-01	7	73	-0.791100E-03
7	74	0.806504E-01	7	77	-0.707904E-01	7	78	0.112403E-01
7	79	0.935400E-01	7	82	-0.405373E-01	7	83	0.391690E-01
7	84	0.116980E 00	7	87	0.145049E-01	7	88	0.862729E-01
7	89	0.153648E 00	7	92	0.945746E-01	7	93	0.153925E 00
7	94	0.202498E 00	7	97	0.204787E 00	7	98	0.241061E 00
7	99	0.261614E 00	7	103	0.343053E 00	7	104	0.326518E 00
7	107	0.504797E 00	7	108	0.449313E 00	7	109	0.390366E 00
7	112	0.642827E 00	7	113	0.543180E 00	7	114	0.445200E 00
7	117	0.741476E 00	7	118	0.610664E 00	7	119	0.482281E 00
8	2	0.651790E 00	8	3	0.585284E 00	8	4	0.484999E 00
8	7	0.623301E 00	8	8	0.559123E 00	8	9	0.483434E 00
8	12	0.509624E 00	8	13	0.503239E 00	8	14	0.446055E 00
8	17	0.384659E 00	8	18	0.408663E 00	8	19	0.400758E 00
8	23	0.337059E 00	8	24	0.351734E 00	8	27	0.242414E 00
8	28	0.279056E 00	8	29	0.307218E 00	8	32	0.194451E 00
8	33	0.233318E 00	8	34	0.268599E 00	8	37	0.154022E 00
8	38	0.194891E 00	8	39	0.235937E 00	8	42	0.120233E 00
8	43	0.163977E 00	8	44	0.209720E 00	8	47	0.877747E-01
8	48	0.135435E 00	8	49	0.186278E 00	8	52	0.592436E-01

8	53	0.111122E 00	8	54	0.166957E 00	8	57	0.343248E-01
8	58	0.908406E-01	8	59	0.151896E 00	8	63	0.758271E-01
8	64	0.141659E 00	8	67	0.856000E-04	8	68	0.668564E-01
8	69	0.137098E 00	8	72	-0.372420E-02	8	73	0.664396E-01
8	74	0.139233E 00	8	77	0.474240E-02	8	78	0.764087E-01
8	79	0.149358E 00	8	82	0.285107E-01	8	83	0.984301E-01
8	84	0.168020E 00	8	87	0.691079E-01	8	88	0.134262E 00
8	89	0.196905E 00	8	92	0.127482E 00	8	93	0.185865E 00
8	94	0.235521E 00	8	97	0.209946E 00	8	98	0.253234E 00
8	99	0.282593E 00	8	103	0.333321E 00	8	104	0.334826E 00
8	107	0.445210E 00	8	108	0.417450E 00	8	109	0.387057E 00
8	112	0.551266E 00	8	113	0.492414E 00	8	114	0.433361E 00
8	117	0.624905E 00	8	118	0.545640E 00	8	119	0.468270E 00
9	2	0.515182E 00	9	3	0.495039E 00	9	4	0.486548E 00
9	7	0.479146E 00	9	8	0.488268E 00	9	9	0.461428E 00
9	12	0.413309E 00	9	13	0.438451E 00	9	14	0.461207E 00
9	17	0.337079E 00	9	18	0.386805E 00	9	19	0.412022E 00
9	23	0.340408E 00	9	24	0.373583E 00	9	27	0.264426E 00
9	28	0.304549E 00	9	29	0.340289E 00	9	32	0.239114E 00
9	33	0.275470E 00	9	34	0.311515E 00	9	37	0.213287E 00
9	38	0.248540E 00	9	39	0.286308E 00	9	42	0.186479E 00
9	43	0.224035E 00	9	44	0.264988E 00	9	47	0.155141E 00
9	48	0.198169E 00	9	49	0.244563E 00	9	52	0.123714E 00
9	53	0.174515E 00	9	54	0.227026E 00	9	57	0.969723E-01
9	58	0.155184E 00	9	59	0.213183E 00	9	63	0.142436E 00
9	64	0.203905E 00	9	67	0.756385E-01	9	68	0.136458E 00
9	69	0.199824E 00	9	72	0.768014E-01	9	73	0.137633E 00
9	74	0.201334E 00	9	77	0.850350E-01	9	78	0.145730E 00
9	79	0.208919E 00	9	82	0.101658E 00	9	83	0.161481E 00
9	84	0.222723E 00	9	87	0.126851E 00	9	88	0.185470E 00
9	89	0.243643E 00	9	92	0.162320E 00	9	93	0.220259E 00
9	94	0.271744E 00	9	97	0.215840E 00	9	98	0.267049E 00
9	99	0.306462E 00	9	103	0.324459E 00	9	104	0.345724E 00
9	107	0.385052E 00	9	108	0.385761E 00	9	109	0.385987E 00
9	112	0.459775E 00	9	113	0.440192E 00	9	114	0.423380E 00
9	117	0.506331E 00	9	118	0.479097E 00	9	119	0.454842E 00
10	2	0.391155E 00	10	3	0.404761E 00	10	4	0.434794E 00
10	7	0.368034E 00	10	8	0.390105E 00	10	9	0.442189E 00
10	12	0.325804E 00	10	13	0.370828E 00	10	14	0.421249E 00
10	17	0.285489E 00	10	18	0.348130E 00	10	19	0.403628E 00
10	23	0.330152E 00	10	24	0.383299E 00	10	27	0.271916E 00
10	28	0.317129E 00	10	29	0.364267E 00	10	32	0.268837E 00
10	33	0.305771E 00	10	34	0.346762E 00	10	37	0.258936E 00
10	38	0.291855E 00	10	39	0.330149E 00	10	42	0.241699E 00
10	43	0.275753E 00	10	44	0.314879E 00	10	47	0.214888E 00
10	48	0.255030E 00	10	49	0.298921E 00	10	52	0.184238E 00
10	53	0.234664E 00	10	54	0.284719E 00	10	57	0.159172E 00
10	58	0.218788E 00	10	59	0.273621E 00	10	63	0.210477E 00
10	64	0.266664E 00	10	67	0.155978E 00	10	68	0.209158E 00
10	69	0.264137E 00	10	72	0.163426E 00	10	73	0.212930E 00
10	74	0.265730E 00	10	77	0.171714E 00	10	78	0.219451E 00
10	79	0.271071E 00	10	82	0.180700E 00	10	83	0.228746E 00
10	84	0.280142E 00	10	87	0.188951E 00	10	88	0.239875E 00
10	89	0.292623E 00	10	92	0.199397E 00	10	93	0.256358E 00
10	94	0.309429E 00	10	97	0.221661E 00	10	98	0.280786E 00
10	99	0.330733E 00	10	103	0.313581E 00	10	104	0.355600E 00
10	107	0.321958E 00	10	108	0.349851E 00	10	109	0.381737E 00

10	112	0.365883E 00	10	113	0.381378E 00	10	114	0.406041E 00
10	117	0.390088E 00	10	118	0.400575E 00	10	119	0.425083E 00
11	2	0.648726E 00	11	3	0.519372E 00	11	4	0.398959E 00
11	7	0.669019E 00	11	8	0.523747E 00	11	9	0.401171E 00
11	12	0.616606E 00	11	13	0.485049E 00	11	14	0.384329E 00
11	17	0.477849E 00	11	18	0.421834E 00	11	19	0.351203E 00
11	23	0.346661E 00	11	24	0.309059E 00	11	27	0.279815E 00
11	28	0.276609E 00	11	29	0.263887E 00	11	32	0.207196E 00
11	33	0.216500E 00	11	34	0.220158E 00	11	37	0.143939E 00
11	38	0.163387E 00	11	39	0.180314E 00	11	42	0.903768E-01
11	43	0.118357E 00	11	44	0.145909E 00	11	47	0.428988E-01
11	48	0.778885E-01	11	49	0.114475E 00	11	52	0.273880E-02
11	53	0.425423E-01	11	54	0.871636E-01	11	57	-0.342994E-01
11	58	0.109701E-01	11	59	0.640901E-01	11	63	-0.161923E-01
11	64	0.459630E-01	11	67	-0.105298E 00	11	68	-0.372660E-01
11	69	0.340957E-01	11	72	-0.123701E 00	11	73	-0.476165E-01
11	74	0.301432E-01	11	77	-0.123457E 00	11	78	-0.436881E-01
11	79	0.360482E-01	11	82	-0.100797E 00	11	83	-0.233603E-01
11	84	0.525940E-01	11	87	-0.535556E-01	11	88	0.154982E-01
11	89	0.816236E-01	11	92	0.176256E-01	11	93	0.730709E-01
11	94	0.121965E 00	11	97	0.113628E 00	11	98	0.147090E 00
11	99	0.171860E 00	11	103	0.233644E 00	11	104	0.227729E 00
11	107	0.363345E 00	11	108	0.325071E 00	11	109	0.284424E 00
11	112	0.484504E 00	11	113	0.409960E 00	11	114	0.336029E 00
11	117	0.583690E 00	11	118	0.477929E 00	11	119	0.376048E 00
12	2	0.591228E 00	12	3	0.499300E 00	12	4	0.407075E 00
12	7	0.611443E 00	12	8	0.507361E 00	12	9	0.411613E 00
12	12	0.559686E 00	12	13	0.486098E 00	12	14	0.397071E 00
12	17	0.450394E 00	12	18	0.424166E 00	12	19	0.371633E 00
12	23	0.358997E 00	12	24	0.335799E 00	12	27	0.297470E 00
12	28	0.301882E 00	12	29	0.296875E 00	12	32	0.242158E 00
12	33	0.252944E 00	12	34	0.259036E 00	12	37	0.190518E 00
12	38	0.207765E 00	12	39	0.223830E 00	12	42	0.142751E 00
12	43	0.167408E 00	12	44	0.192679E 00	12	47	0.954896E-01
12	48	0.128177E 00	12	49	0.162772E 00	12	52	0.520010E-01
12	53	0.923254E-01	12	54	0.136035E 00	12	57	0.120471E-01
12	58	0.602964E-01	12	59	0.113111E 00	12	63	0.336967E-01
12	64	0.950500E-01	12	67	-0.524477E-01	12	68	0.140158E-01
12	69	0.831568E-01	12	72	-0.677518E-01	12	73	0.464890E-02
12	74	0.787883E-01	12	77	-0.670677E-01	12	78	0.789560E-02
12	79	0.834444E-01	12	82	-0.475296E-01	12	83	0.253574E-01
12	84	0.976257E-01	12	87	-0.795270E-02	12	88	0.584366E-01
12	89	0.122802E 00	12	92	0.515598E-01	12	93	0.107802E 00
12	94	0.158056E 00	12	97	0.133258E 00	12	98	0.171971E 00
12	99	0.201935E 00	12	103	0.247795E 00	12	104	0.251346E 00
12	107	0.352855E 00	12	108	0.328202E 00	12	109	0.301758E 00
12	112	0.457927E 00	12	113	0.402682E 00	12	114	0.347987E 00
12	117	0.541826E 00	12	118	0.461798E 00	12	119	0.384574E 00
13	2	0.531940E 00	13	3	0.478845E 00	13	4	0.425532E 00
13	7	0.530931E 00	13	8	0.502551E 00	13	9	0.435825E 00
13	12	0.492474E 00	13	13	0.476920E 00	13	14	0.436053E 00
13	17	0.405135E 00	13	18	0.440404E 00	13	19	0.407179E 00
13	23	0.375598E 00	13	24	0.375086E 00	13	27	0.318030E 00
13	28	0.333871E 00	13	29	0.340409E 00	13	32	0.281993E 00
13	33	0.296587E 00	13	34	0.307973E 00	13	37	0.243124E 00
13	38	0.259958E 00	13	39	0.277248E 00	13	42	0.201672E 00
13	43	0.224496E 00	13	44	0.249210E 00	13	47	0.154977E 00

13	48	0.186744E	00	13	49	0.220862E	00	13	52	0.108312E	00
13	53	0.150626E	00	13	54	0.194798E	00	13	57	0.657734E	-01
13	58	0.118507E	00	13	59	0.172190E	00	13	63	0.930079E	-01
13	64	0.154402E	00	13	67	0.100133E	-01	13	68	0.753010E	-01
13	69	0.142670E	00	13	72	-0.139260E	-02	13	73	0.673029E	-01
13	74	0.137969E	00	13	77	-0.130000E	-03	13	78	0.698493E	-01
13	79	0.141276E	00	13	82	0.159912E	-01	13	83	0.842535E	-01
13	84	0.153025E	00	13	87	0.464138F	-01	13	88	0.110540E	00
13	89	0.173791E	00	13	92	0.921156E	-01	13	93	0.150320E	00
13	94	0.203246E	00	13	97	0.157121E	00	13	98	0.203111E	00
13	99	0.240348E	00	13	103	0.266749E	00	13	104	0.282637E	00
13	107	0.342415E	00	13	108	0.334901F	00	13	109	0.326343E	00
13	112	0.429919E	00	13	113	0.397979E	00	13	114	0.367226E	00
13	117	0.496065E	00	13	118	0.448112E	00	13	119	0.401084E	00
14	2	0.455985E	00	14	3	0.444437E	00	14	4	0.434278E	00
14	7	0.443050E	00	14	8	0.448348E	00	14	9	0.461193E	00
14	12	0.398045E	00	14	13	0.441213E	00	14	14	0.437006E	00
14	17	0.351022E	00	14	18	0.404597E	00	14	19	0.442384E	00
14	23	0.374068E	00	14	24	0.401893E	00	14	27	0.318477E	00
14	28	0.347732E	00	14	29	0.372525E	00	14	32	0.302179E	00
14	33	0.324193E	00	14	34	0.346205E	00	14	37	0.277800E	00
14	38	0.298001E	00	14	39	0.321107E	00	14	42	0.245943E	00
14	43	0.270055E	00	14	44	0.297715E	00	14	47	0.204144E	00
14	48	0.236993E	00	14	49	0.272873E	00	14	52	0.159113E	00
14	53	0.204110E	00	14	54	0.249606E	00	14	57	0.118744E	00
14	58	0.175353E	00	14	59	0.229436E	00	14	63	0.153995E	00
14	64	0.213840E	00	14	67	0.792555E	-01	14	68	0.140695E	00
14	69	0.203798E	00	14	72	0.738562E	-01	14	73	0.135611E	00
14	74	0.199769E	00	14	77	0.763910E	-01	14	78	0.137997E	00
14	79	0.202117E	00	14	82	0.877289E	-01	14	83	0.148396E	00
14	84	0.210896E	00	14	87	0.106960E	00	14	88	0.166469E	00
14	89	0.226442E	00	14	92	0.135763E	00	14	93	0.194471E	00
14	94	0.248827E	00	14	97	0.180282E	00	14	98	0.233182E	00
14	99	0.277559E	00	14	103	0.281668E	00	14	104	0.310966E	00
14	107	0.323397E	00	14	108	0.334532E	00	14	109	0.346185E	00
14	112	0.389909E	00	14	113	0.383393E	00	14	114	0.379962E	00
14	117	0.436484E	00	14	118	0.421047E	00	14	119	0.409485E	00
15	2	0.369769E	00	15	3	0.387589E	00	15	4	0.418385E	00
15	7	0.354033E	00	15	8	0.382565E	00	15	9	0.424550E	00
15	12	0.322978E	00	15	13	0.366992E	00	15	14	0.432204E	00
15	17	0.292711E	00	15	18	0.355794E	00	15	19	0.414373E	00
15	23	0.346631E	00	15	24	0.401652E	00	15	27	0.298657E	00
15	28	0.340384E	00	15	29	0.386045E	00	15	32	0.301151E	00
15	33	0.332798E	00	15	34	0.369951E	00	15	37	0.292895E	00
15	38	0.319782E	00	15	39	0.353048E	00	15	42	0.273554E	00
15	43	0.301953E	00	15	44	0.336060E	00	15	47	0.241527E	00
15	48	0.277322E	00	15	49	0.317107E	00	15	52	0.203528E	00
15	53	0.251642E	00	15	54	0.299082E	00	15	57	0.170610E	00
15	58	0.230035E	00	15	59	0.283722E	00	15	63	0.216231E	00
15	64	0.272429E	00	15	67	0.155655E	00	15	68	0.209996E	00
15	69	0.265746E	00	15	72	0.158548E	00	15	73	0.209504E	00
15	74	0.263479E	00	15	77	0.163099E	00	15	78	0.212313E	00
15	79	0.265287E	00	15	82	0.169054E	00	15	83	0.218421E	00
15	84	0.271128E	00	15	87	0.174799E	00	15	88	0.226685E	00
15	89	0.280549E	00	15	92	0.183191E	00	15	93	0.240415E	00
15	94	0.294416E	00	15	97	0.202932E	00	15	98	0.261943E	00
15	99	0.312905E	00	15	103	0.291820E	00	15	104	0.335232E	00

15	107	0.295308E 00	15	108	0.325785E 00	15	109	0.359436E 00
15	112	0.337750E 00	15	113	0.356743E 00	15	114	0.382942E 00
15	117	0.363755E 00	15	118	0.378301E 00	15	119	0.403131E 00
16	2	0.340457E 00	16	3	0.294723E 00	16	4	0.248965E 00
16	7	0.381805E 00	16	8	0.325477E 00	16	9	0.269495E 00
16	12	0.407197E 00	16	13	0.344493E 00	16	14	0.282247E 00
16	17	0.417003E 00	16	18	0.349926E 00	16	19	0.286541E 00
16	23	0.342535E 00	16	24	0.281885E 00	16	27	0.378406E 00
16	28	0.323517E 00	16	29	0.268691E 00	16	32	0.338448E 00
16	33	0.293100E 00	16	34	0.248069E 00	16	37	0.285302E 00
16	38	0.253279E 00	16	39	0.221243E 00	16	42	0.223293E 00
16	43	0.206631E 00	16	44	0.190000E 00	16	47	0.156726E 00
16	48	0.156610E 00	16	49	0.156453E 00	16	52	0.900590E-01
16	53	0.106412E 00	16	54	0.122904E 00	16	57	0.278870E-01
16	58	0.597484E-01	16	59	0.915823E-01	16	63	0.197907E-01
16	64	0.646819E-01	16	67	-0.665688E-01	16	68	-0.112841E-01
16	69	0.440662E-01	16	72	-0.924176E-01	16	73	-0.306834E-01
16	74	0.310462E-01	16	77	-0.101247E 00	16	78	-0.373188E-01
16	79	0.266336E-01	16	82	-0.925590E-01	16	83	-0.307383E-01
16	84	0.310644E-01	16	87	-0.667316E-01	16	88	-0.113310E-01
16	89	0.441115E-01	16	92	-0.256449E-01	16	93	0.198122E-01
16	94	0.647882E-01	16	97	0.279669E-01	16	98	0.599103E-01
16	99	0.917913E-01	16	103	0.106790E 00	16	104	0.123258E 00
16	107	0.157472E 00	16	108	0.157272E 00	16	109	0.156989E 00
16	112	0.224505E 00	16	113	0.207629E 00	16	114	0.190737E 00
16	117	0.286985E 00	16	118	0.254535E 00	16	119	0.222145E 00
17	2	0.390182E 00	17	3	0.351386E 00	17	4	0.312378E 00
17	7	0.422614E 00	17	8	0.381368E 00	17	9	0.333901E 00
17	12	0.447222E 00	17	13	0.400938E 00	17	14	0.347414E 00
17	17	0.440330E 00	17	18	0.414295E 00	17	19	0.349850E 00
17	23	0.398023E 00	17	24	0.345991E 00	17	27	0.409787E 00
17	28	0.375174E 00	17	29	0.331681E 00	17	32	0.377651E 00
17	33	0.344993E 00	17	34	0.309647E 00	17	37	0.330975E 00
17	38	0.306360E 00	17	39	0.281667E 00	17	42	0.273744E 00
17	43	0.262102E 00	17	44	0.251210E 00	17	47	0.204986E 00
17	48	0.210098E 00	17	49	0.215805E 00	17	52	0.133403E 00
17	53	0.156964E 00	17	54	0.180234E 00	17	57	0.664161E-01
17	58	0.107583E 00	17	59	0.147005E 00	17	63	0.659798E-01
17	64	0.118585E 00	17	67	-0.281376E-01	17	68	0.343371E-01
17	69	0.969473E-01	17	72	-0.530326E-01	17	73	0.149503E-01
17	74	0.833625E-01	17	77	-0.614197E-01	17	78	0.835250E-02
17	79	0.787541E-01	17	82	-0.523389E-01	17	83	0.150874E-01
17	84	0.830160E-01	17	87	-0.275972E-01	17	88	0.342767E-01
17	89	0.964321E-01	17	92	0.122042E-01	17	93	0.656928E-01
17	94	0.117946E 00	17	97	0.661610E-01	17	98	0.107173E 00
17	99	0.146349E 00	17	103	0.156732E 00	17	104	0.179716E 00
17	107	0.205581E 00	17	108	0.210516E 00	17	109	0.215576E 00
17	112	0.276548E 00	17	113	0.263606E 00	17	114	0.251337E 00
17	117	0.339605E 00	17	118	0.311758E 00	17	119	0.284372E 00
18	2	0.404391E 00	18	3	0.383910E 00	18	4	0.361902E 00
18	7	0.425647E 00	18	8	0.408319E 00	18	9	0.385542E 00
18	12	0.426091E 00	18	13	0.440401E 00	18	14	0.401974E 00
18	17	0.422866E 00	18	18	0.439272E 00	18	19	0.414110E 00
18	23	0.435534E 00	18	24	0.400382E 00	18	27	0.410796E 00
18	28	0.400949E 00	18	29	0.382752E 00	18	32	0.391433E 00
18	33	0.376810E 00	18	34	0.358664E 00	18	37	0.356151E 00
18	38	0.343226E 00	18	39	0.331250E 00	18	42	0.307079E 00

18	43	0.303765E 00	18	44	0.302346E 00	18	47	0.242723E 00
18	48	0.254794E 00	18	49	0.268313E 00	18	52	0.172993E 00
18	53	0.203933E 00	18	54	0.234113E 00	18	57	0.107917E 00
18	58	0.156944E 00	18	59	0.202311E 00	18	63	0.118397E 00
18	64	0.175390E 00	18	67	0.253259E-01	18	68	0.901138E-01
18	69	0.155171E 00	18	72	0.513780E-02	18	73	0.733820E-01
18	74	0.142654E 00	18	77	-0.129870E-02	18	78	0.678610E-01
18	79	0.138483E 00	18	82	0.676130E-02	18	83	0.739763E-01
18	84	0.142469E 00	18	87	0.271013E-01	18	88	0.905747E-01
18	89	0.154795E 00	18	92	0.601620E-01	18	93	0.118405E 00
18	94	0.174793E 00	18	97	0.107518E 00	18	98	0.156371E 00
18	99	0.201549E 00	18	103	0.203054E 00	18	104	0.233340E 00
18	107	0.241386E 00	18	108	0.254291E 00	18	109	0.267738E 00
18	112	0.308229E 00	18	113	0.304402E 00	18	114	0.302131E 00
18	117	0.364295E 00	18	118	0.348490E 00	18	119	0.334060E 00
19	2	0.383926E 00	19	3	0.385457E 00	19	4	0.389053E 00
19	7	0.388655E 00	19	8	0.401668E 00	19	9	0.411986E 00
19	12	0.373306E 00	19	13	0.409789E 00	19	14	0.442363E 00
19	17	0.352747E 00	19	18	0.419245E 00	19	19	0.425789E 00
19	23	0.405879E 00	19	24	0.440997E 00	19	27	0.375823E 00
19	28	0.395498E 00	19	29	0.409684E 00	19	32	0.373095E 00
19	33	0.379591E 00	19	34	0.386416E 00	19	37	0.352599E 00
19	38	0.355691E 00	19	39	0.362102E 00	19	42	0.316252E 00
19	43	0.324725E 00	19	44	0.336950E 00	19	47	0.263327E 00
19	48	0.284203E 00	19	49	0.307727E 00	19	52	0.203098E 00
19	53	0.241308E 00	19	54	0.278482E 00	19	57	0.147452E 00
19	58	0.202224E 00	19	59	0.251594E 00	19	63	0.171624E 00
19	64	0.229273E 00	19	67	0.888433E-01	19	68	0.150602E 00
19	69	0.212912E 00	19	72	0.768172E-01	19	73	0.139022E 00
19	74	0.203034E 00	19	77	0.735744E-01	19	78	0.135462E 00
19	79	0.199840E 00	19	82	0.793154E-01	19	83	0.140152E 00
19	84	0.203247E 00	19	87	0.919771E-01	19	88	0.151765E 00
19	89	0.212958E 00	19	92	0.113072E 00	19	93	0.172178E 00
19	94	0.229036E 00	19	97	0.147135E 00	19	98	0.201763E 00
19	99	0.251053E 00	19	103	0.240029E 00	19	104	0.277759E 00
19	107	0.260196E 00	19	108	0.282934E 00	19	109	0.307054E 00
19	112	0.315653E 00	19	113	0.324480E 00	19	114	0.336559E 00
19	117	0.358444E 00	19	118	0.359495E 00	19	119	0.364151E 00
20	2	0.341301E 00	20	3	0.363978E 00	20	4	0.395801E 00
20	7	0.333529E 00	20	8	0.366104E 00	20	9	0.408701E 00
20	12	0.312512E 00	20	13	0.361956E 00	20	14	0.416047E 00
20	17	0.295703E 00	20	18	0.355807E 00	20	19	0.427553E 00
20	23	0.358865E 00	20	24	0.415006E 00	20	27	0.323378E 00
20	28	0.361373E 00	20	29	0.406947E 00	20	32	0.333148E 00
20	33	0.359591E 00	20	34	0.393832E 00	20	37	0.327983E 00
20	38	0.348847E 00	20	39	0.377591E 00	20	42	0.307596E 00
20	43	0.330236E 00	20	44	0.359491E 00	20	47	0.271008E 00
20	48	0.302324E 00	20	49	0.337994E 00	20	52	0.226014E 00
20	53	0.271777E 00	20	54	0.316496E 00	20	57	0.185579E 00
20	58	0.244836E 00	20	59	0.297167E 00	20	63	0.225951E 00
20	64	0.281783E 00	20	67	0.160250E 00	20	68	0.215195E 00
20	69	0.271124E 00	20	72	0.159072E 00	20	73	0.210697E 00
20	74	0.265082E 00	20	77	0.160002E 00	20	78	0.209798E 00
20	79	0.263297E 00	20	82	0.162634E 00	20	83	0.212467E 00
20	84	0.265725E 00	20	87	0.165002E 00	20	88	0.217207E 00
20	89	0.271651E 00	20	92	0.169997E 00	20	93	0.227209E 00
20	94	0.281974E 00	20	97	0.185524E 00	20	98	0.244625E 00

20	99	0.296904E 00	20	103	0.270194E 00	20	104	0.315846E 00
20	107	0.266215E 00	20	108	0.300306E 00	20	109	0.337190E 00
20	112	0.305173E 00	20	113	0.329008E 00	20	114	0.358817E 00
20	117	0.331224E 00	20	118	0.350930E 00	20	119	0.378686E 00
21	2	0.193260E 00	21	3	0.199158E 00	21	4	0.201353E 00
21	7	0.263159E 00	21	8	0.255684E 00	21	9	0.241895E 00
21	12	0.341053E 00	21	13	0.319065E 00	21	14	0.283914E 00
21	17	0.434488E 00	21	18	0.387811E 00	21	19	0.323126E 00
21	23	0.446335E 00	21	24	0.354345E 00	21	27	0.608405E 00
21	28	0.482687E 00	21	29	0.371395E 00	21	32	0.602373E 00
21	33	0.482047E 00	21	34	0.370936E 00	21	37	0.548583E 00
21	38	0.448016E 00	21	39	0.351495E 00	21	42	0.460876E 00
21	43	0.387560E 00	21	44	0.315899E 00	21	47	0.349813E 00
21	48	0.309775E 00	21	49	0.268736E 00	21	52	0.227967E 00
21	53	0.224299E 00	21	54	0.216118E 00	21	57	0.112338E 00
21	58	0.142353E 00	21	59	0.163675E 00	21	63	0.716965E-01
21	64	0.116397E 00	21	67	-0.484930E-01	21	68	0.164117E-01
21	69	0.778236E-01	21	72	-0.940732E-01	21	73	-0.211597E-01
21	74	0.497368E-01	21	77	-0.116676E 00	21	78	-0.417747E-01
21	79	0.328259E-01	21	82	-0.118201E 00	21	83	-0.461912E-01
21	84	0.267884E-01	21	87	-0.102265E 00	21	88	-0.375249E-01
21	89	0.296769E-01	21	92	-0.723430E-01	21	93	-0.184253E-01
21	94	0.400645E-01	21	97	-0.356998E-01	21	98	0.661980E-02
21	99	0.564039E-01	21	103	0.358703E-01	21	104	0.774518E-01
21	107	0.369226E-01	21	108	0.685874E-01	21	109	0.102547E 00
21	112	0.807835E-01	21	113	0.106044E 00	21	114	0.131587E 00
21	117	0.132542E 00	21	118	0.149553E 00	21	119	0.164697E 00
22	2	0.243264E 00	22	3	0.249484E 00	22	4	0.252779E 00
22	7	0.298333E 00	22	8	0.296968E 00	22	9	0.288933E 00
22	12	0.354101E 00	22	13	0.350313E 00	22	14	0.325631E 00
22	17	0.434609E 00	22	18	0.409367E 00	22	19	0.359189E 00
22	23	0.464259E 00	22	24	0.383441E 00	22	27	0.577642E 00
22	28	0.485587E 00	22	29	0.396981E 00	22	32	0.564814E 00
22	33	0.479753E 00	22	34	0.393255E 00	22	37	0.522771E 00
22	38	0.446821E 00	22	39	0.372979E 00	22	42	0.452407E 00
22	43	0.397234E 00	22	44	0.343503E 00	22	47	0.352149E 00
22	48	0.325687E 00	22	49	0.298824E 00	22	52	0.240326E 00
22	53	0.247109E 00	22	54	0.249706E 00	22	57	0.134183E 00
22	58	0.172121E 00	22	59	0.201209E 00	22	63	0.108219E 00
22	64	0.157873E 00	22	67	-0.772610E-02	22	68	0.589435E-01
22	69	0.122872E 00	22	72	-0.469273E-01	22	73	0.259946E-01
22	74	0.977440E-01	22	77	-0.660484E-01	22	78	0.830520E-02
22	79	0.830647E-01	22	82	-0.653515E-01	22	83	0.552870E-02
22	84	0.777430E-01	22	87	-0.510288E-01	22	88	0.141544E-01
22	89	0.816042E-01	22	92	-0.238884E-01	22	93	0.330141E-01
22	94	0.928540E-01	22	97	0.117315E-01	22	98	0.588059E-01
22	99	0.110207E 00	22	103	0.901023E-01	22	104	0.132404E 00
22	107	0.943236E-01	22	108	0.125314E 00	22	109	0.158414E 00
22	112	0.141269E 00	22	113	0.163914E 00	22	114	0.187559E 00
22	117	0.191172E 00	22	118	0.205625E 00	22	119	0.219399E 00
23	2	0.290733E 00	23	3	0.300047E 00	23	4	0.308083E 00
23	7	0.327600E 00	23	8	0.336862E 00	23	9	0.339676E 00
23	12	0.359663E 00	23	13	0.375819E 00	23	14	0.372943E 00
23	17	0.402755E 00	23	18	0.435669E 00	23	19	0.403419E 00
23	23	0.468403E 00	23	24	0.430646E 00	23	27	0.511666E 00
23	28	0.491207E 00	23	29	0.429725E 00	23	32	0.514839E 00
23	33	0.468406E 00	23	34	0.419377E 00	23	37	0.485625E 00

23	38	0.440450E 00	23	39	0.395970E 00	23	42	0.429170E 00
23	43	0.396709E 00	23	44	0.366268E 00	23	47	0.345408E 00
23	48	0.335536E 00	23	49	0.326221E 00	23	52	0.249399E 00
23	53	0.268051E 00	23	54	0.283057E 00	23	57	0.158228E 00
23	58	0.204053E 00	23	59	0.240966E 00	23	63	0.150517E 00
23	64	0.203801E 00	23	67	0.444114E-01	23	68	0.110183E 00
23	69	0.174169E 00	23	72	0.142904E-01	23	73	0.838087E-01
23	74	0.153223E 00	23	77	-0.265900E-03	23	78	0.698768E-01
23	79	0.141333E 00	23	82	0.160000E-05	23	83	0.679797E-01
23	84	0.137838E 00	23	87	0.113955E-01	23	88	0.757604E-01
23	89	0.142294E 00	23	92	0.335818E-01	23	93	0.930569E-01
23	94	0.153726E 00	23	97	0.657436E-01	23	98	0.118066E 00
23	99	0.171224E 00	23	103	0.149871E 00	23	104	0.193617E 00
23	107	0.154601E 00	23	108	0.186083E 00	23	109	0.219574E 00
23	112	0.202729E 00	23	113	0.224323E 00	23	114	0.247884E 00
23	117	0.248617E 00	23	118	0.262648E 00	23	119	0.277589E 00
24	2	0.311438E 00	24	3	0.328762E 00	24	4	0.347765E 00
24	7	0.329140E 00	24	8	0.352299E 00	24	9	0.373579E 00
24	12	0.337169E 00	24	13	0.376357E 00	24	14	0.401908E 00
24	17	0.349443E 00	24	18	0.403032E 00	24	19	0.441032E 00
24	23	0.435684E 00	24	24	0.434412E 00	24	27	0.428211E 00
24	28	0.440938E 00	24	29	0.457788E 00	24	32	0.444198E 00
24	33	0.437622E 00	24	34	0.430776E 00	24	37	0.430807E 00
24	38	0.417163E 00	24	39	0.407146E 00	24	42	0.391611E 00
24	43	0.384024E 00	24	44	0.380327E 00	24	47	0.328203E 00
24	48	0.336476E 00	24	49	0.346997E 00	24	52	0.252531E 00
24	53	0.283594E 00	24	54	0.311905E 00	24	57	0.181071E 00
24	58	0.234047E 00	24	59	0.278315E 00	24	63	0.194038E 00
24	64	0.249230E 00	24	67	0.103291E 00	24	68	0.165236E 00
24	69	0.226505E 00	24	72	0.846999E-01	24	73	0.147154E 00
24	74	0.210748E 00	24	77	0.757133E-01	24	78	0.137647E 00
24	79	0.202000E 00	24	82	0.758304E-01	24	83	0.136621E 00
24	84	0.200045E 00	24	87	0.818563E-01	24	88	0.141754E 00
24	89	0.203918E 00	24	92	0.951236E-01	24	93	0.154579E 00
24	94	0.213696E 00	24	97	0.118703E 00	24	98	0.175095E 00
24	99	0.228992E 00	24	103	0.203194E 00	24	104	0.248939E 00
24	107	0.202092E 00	24	108	0.236041E 00	24	109	0.272149E 00
24	112	0.245846E 00	24	113	0.269818E 00	24	114	0.297098E 00
24	117	0.283132E 00	24	118	0.301204E 00	24	119	0.322508E 00
25	2	0.309114E 00	25	3	0.337010E 00	25	4	0.371755E 00
25	7	0.308351E 00	25	8	0.344835E 00	25	9	0.387581E 00
25	12	0.297711E 00	25	13	0.349409E 00	25	14	0.402451E 00
25	17	0.292580E 00	25	18	0.355509E 00	25	19	0.414136E 00
25	23	0.363722E 00	25	24	0.430950E 00	25	27	0.343768E 00
25	28	0.377691E 00	25	29	0.422650E 00	25	32	0.361684E 00
25	33	0.383197E 00	25	34	0.416336E 00	25	37	0.360999E 00
25	38	0.376491E 00	25	39	0.402124E 00	25	42	0.340938E 00
25	43	0.358381E 00	25	44	0.383796E 00	25	47	0.301050E 00
25	48	0.328261E 00	25	49	0.360434E 00	25	52	0.250093E 00
25	53	0.293748E 00	25	54	0.336044E 00	25	57	0.203086E 00
25	58	0.262277E 00	25	59	0.313263E 00	25	63	0.239046E 00
25	64	0.294240E 00	25	67	0.169411E 00	25	68	0.224401E 00
25	69	0.279967E 00	25	72	0.164813E 00	25	73	0.216324E 00
25	74	0.270385E 00	25	77	0.162365E 00	25	78	0.211872E 00
25	79	0.265090E 00	25	82	0.161479E 00	25	83	0.210975E 00
25	84	0.264043E 00	25	87	0.159845E 00	25	88	0.211766E 00
25	89	0.266231E 00	25	92	0.160458E 00	25	93	0.217388E 00

25	94	0.272638E 00	25	97	0.170618E 00	25	98	0.229917E 00
25	99	0.283540E 00	25	103	0.250327E 00	25	104	0.298559E 00
25	107	0.237475E 00	25	108	0.275646E 00	25	109	0.316445E 00
25	112	0.271673E 00	25	113	0.301001E 00	25	114	0.335504E 00
25	117	0.296316E 00	25	118	0.321953E 00	25	119	0.354158E 00
26	2	0.817345E-01	26	3	0.128689E 00	26	4	0.169734E 00
26	7	0.172109E 00	26	8	0.203382E 00	26	9	0.224916E 00
26	12	0.286978E 00	26	13	0.297983E 00	26	14	0.289143E 00
26	17	0.436753E 00	26	18	0.411031E 00	26	19	0.357025E 00
26	23	0.526150E 00	26	24	0.419599E 00	26	27	0.807460E 00
26	28	0.617566E 00	26	29	0.465842E 00	26	32	0.851976E 00
26	33	0.657794E 00	26	34	0.486916E 00	26	37	0.807049E 00
26	38	0.637398E 00	26	39	0.478348E 00	26	42	0.702617E 00
26	43	0.571332E 00	26	44	0.444404E 00	26	47	0.549500E 00
26	48	0.468202E 00	26	49	0.385726E 00	26	52	0.372889E 00
26	53	0.348555E 00	26	54	0.315341E 00	26	57	0.203188E 00
26	58	0.231594E 00	26	59	0.242485E 00	26	63	0.130116E 00
26	64	0.175179E 00	26	67	-0.250763E-01	26	68	0.504362E-01
26	69	0.118882E 00	26	72	-0.908117E-01	26	73	-0.531570E-02
26	74	0.760612E-01	26	77	-0.127150E 00	26	78	-0.395103E-01
26	79	0.472723E-01	26	82	-0.137273E 00	26	83	-0.537283E-01
26	84	0.313885E-01	26	87	-0.129329E 00	26	88	-0.540053E-01
26	89	0.256225E-01	26	92	-0.107442E 00	26	93	-0.441316E-01
26	94	0.277459E-01	26	97	-0.828282E-01	26	98	-0.302297E-01
26	99	0.358486E-01	26	103	-0.139730E-01	26	104	0.489819E-01
26	107	-0.519986E-01	26	108	0.550400E-02	26	109	0.675000E-01
26	112	-0.255841E-01	26	113	0.331271E-01	26	114	0.928183E-01
26	117	0.176245E-01	26	118	0.736437E-01	26	119	0.126892E 00
27	2	0.141888E 00	27	3	0.181656E 00	27	4	0.217292E 00
27	7	0.212285E 00	27	8	0.242438E 00	27	9	0.264157E 00
27	12	0.298319E 00	27	13	0.318463E 00	27	14	0.318106E 00
27	17	0.413000E 00	27	18	0.411123E 00	27	19	0.375121E 00
27	23	0.509878E 00	27	24	0.427212E 00	27	27	0.715519E 00
27	28	0.593540E 00	27	29	0.463427E 00	27	32	0.765049E 00
27	33	0.616578E 00	27	34	0.480866E 00	27	37	0.722127E 00
27	38	0.595087E 00	27	39	0.470615E 00	27	42	0.637651E 00
27	43	0.536763E 00	27	44	0.439250E 00	27	47	0.506734E 00
27	48	0.447253E 00	27	49	0.386803E 00	27	52	0.354222E 00
27	53	0.343463E 00	27	54	0.324864E 00	27	57	0.207359E 00
27	58	0.242358E 00	27	59	0.261249E 00	27	63	0.155306E 00
27	64	0.202839E 00	27	67	0.152216E-01	27	68	0.875708E-01
27	69	0.154270E 00	27	72	-0.393581E-01	27	73	0.405590E-01
27	74	0.117587E 00	27	77	-0.695513E-01	27	78	0.118728E-01
27	79	0.932261E-01	27	82	-0.777119E-01	27	83	0.373400E-03
27	84	0.802678E-01	27	87	-0.710219E-01	27	88	0.826900E-03
27	89	0.764180E-01	27	92	-0.520047E-01	27	93	0.109164E-01
27	94	0.800297E-01	27	97	-0.281168E-01	27	98	0.261181E-01
27	99	0.895727E-01	27	103	0.451377E-01	27	104	0.104093E 00
27	107	0.160554E-01	27	108	0.678025E-01	27	109	0.123450E 00
27	112	0.467130E-01	27	113	0.966753E-01	27	114	0.148254E 00
27	117	0.878652E-01	27	118	0.134340E 00	27	119	0.179587E 00
28	2	0.200036E 00	28	3	0.234259E 00	28	4	0.266700E 00
28	7	0.248273E 00	28	8	0.279204E 00	28	9	0.304274E 00
28	12	0.302790E 00	28	13	0.334373E 00	28	14	0.347305E 00
28	17	0.378223E 00	28	18	0.401457E 00	28	19	0.394701E 00
28	23	0.491580E 00	28	24	0.438734E 00	28	27	0.599692E 00
28	28	0.545651E 00	28	29	0.475535E 00	28	32	0.633340E 00

28	33	0.573311E 00	28	34	0.477527E 00	28	37	0.615545E 00
28	38	0.538466E 00	28	39	0.463077E 00	28	42	0.552508E 00
28	43	0.491842E 00	28	44	0.432341E 00	28	47	0.451206E 00
28	48	0.419344E 00	28	49	0.387213E 00	28	52	0.329536E 00
28	53	0.335913E 00	28	54	0.335707E 00	28	57	0.212224E 00
28	58	0.255137E 00	28	59	0.283716E 00	28	63	0.186627E 00
28	64	0.236530E 00	28	67	0.668907E-01	28	68	0.134198E 00
28	69	0.197651E 00	28	72	0.266365E-01	28	73	0.982122E-01
28	74	0.168496E 00	28	77	0.399260E-02	28	78	0.761229E-01
28	79	0.149276E 00	28	82	-0.267130E-02	28	83	0.672014E-01
28	84	0.139335E 00	28	87	0.986300E-03	28	88	0.673054E-01
28	89	0.136873E 00	28	92	0.142955E-01	28	93	0.758721E-01
28	94	0.141045E 00	28	97	0.344003E-01	28	98	0.904326E-01
28	99	0.150872E 00	28	103	0.110357E 00	28	104	0.165547E 00
28	107	0.877811E-01	28	108	0.134525E 00	28	109	0.184529E 00
28	112	0.120858E 00	28	113	0.163066E 00	28	114	0.207650E 00
28	117	0.158062E 00	28	118	0.196272E 00	28	119	0.235125E 00
29	2	0.246731E 00	29	3	0.278796E 00	29	4	0.312149E 00
29	7	0.273029E 00	29	8	0.307661E 00	29	9	0.340331E 00
29	12	0.297936E 00	29	13	0.341334E 00	29	14	0.372586E 00
29	17	0.334808E 00	29	18	0.384070E 00	29	19	0.409765E 00
29	23	0.432262E 00	29	24	0.457836E 00	29	27	0.463935E 00
29	28	0.480323E 00	29	29	0.457502E 00	29	32	0.503352E 00
29	33	0.488090E 00	29	34	0.482747E 00	29	37	0.501586E 00
29	38	0.475724E 00	29	39	0.452678E 00	29	42	0.463267E 00
29	43	0.441746E 00	29	44	0.424096E 00	29	47	0.392143E 00
29	48	0.388825E 00	29	49	0.387262E 00	29	52	0.303059E 00
29	53	0.327362E 00	29	54	0.347136E 00	29	57	0.217273E 00
29	58	0.268520E 00	29	59	0.307621E 00	29	63	0.220044E 00
29	64	0.272439E 00	29	67	0.122622E 00	29	68	0.184196E 00
29	69	0.243889E 00	29	72	0.980632E-01	29	73	0.160126E 00
29	74	0.222677E 00	29	77	0.836163E-01	29	78	0.145002E 00
29	79	0.208704E 00	29	82	0.782433E-01	29	83	0.138528E 00
29	84	0.201733E 00	29	87	0.777224E-01	29	88	0.137412E 00
29	89	0.200059E 00	29	92	0.833399E-01	29	93	0.143011E 00
29	94	0.203876E 00	29	97	0.970436E-01	29	98	0.155066E 00
29	99	0.212841E 00	29	103	0.173799E 00	29	104	0.226415E 00
29	107	0.153691E 00	29	108	0.197347E 00	29	109	0.243800E 00
29	112	0.186498E 00	29	113	0.223668E 00	29	114	0.264193E 00
29	117	0.217729E 00	29	118	0.250968E 00	29	119	0.287061E 00
30	2	0.276383E 00	30	3	0.309685E 00	30	4	0.348349E 00
30	7	0.280961E 00	30	8	0.321203E 00	30	9	0.365556E 00
30	12	0.279276E 00	30	13	0.332585E 00	30	14	0.383657E 00
30	17	0.285127E 00	30	18	0.347629E 00	30	19	0.403188E 00
30	23	0.367436E 00	30	24	0.419869E 00	30	27	0.357836E 00
30	28	0.385294E 00	30	29	0.440232E 00	30	32	0.383460E 00
30	33	0.400543E 00	30	34	0.432771E 00	30	37	0.388213E 00
30	38	0.399340E 00	30	39	0.424375E 00	30	42	0.370012E 00
30	43	0.383543E 00	30	44	0.407136E 00	30	47	0.328783E 00
30	48	0.352874E 00	30	49	0.382974E 00	30	52	0.273758E 00
30	53	0.315906E 00	30	54	0.356600E 00	30	57	0.221930E 00
30	58	0.281258E 00	30	59	0.331193E 00	30	63	0.254863E 00
30	64	0.309260E 00	30	67	0.182878E 00	30	68	0.237293E 00
30	69	0.291970E 00	30	72	0.175758E 00	30	73	0.226305E 00
30	74	0.279281E 00	30	77	0.170340E 00	30	78	0.218638E 00
30	79	0.270724E 00	30	82	0.165809E 00	30	83	0.214141E 00
30	84	0.266235E 00	30	87	0.159709E 00	30	88	0.210728E 00

30	89	0.264597E 00	30	92	0.155187E 00	30	93	0.211549E 00
30	94	0.266892E 00	30	97	0.159203E 00	30	98	0.218728E 00
30	99	0.273503E 00	30	103	0.233526E 00	30	104	0.284289E 00
30	107	0.211336E 00	30	108	0.253568E 00	30	109	0.298351E 00
30	112	0.240112E 00	30	113	0.274936E 00	30	114	0.314384E 00
30	117	0.262327E 00	30	118	0.293980E 00	30	119	0.331202E 00
31	2	0.417990E-02	31	3	0.793021E-01	31	4	0.147853E 00
31	7	0.102058E 00	31	8	0.161693E 00	31	9	0.210184E 00
31	12	0.233712E 00	31	13	0.271565E 00	31	14	0.286655E 00
31	17	0.410161E 00	31	18	0.407618E 00	31	19	0.372375E 00
31	23	0.558057E 00	31	24	0.457240E 00	31	27	0.883563E 00
31	28	0.695218E 00	31	29	0.527605E 00	31	32	0.103961E 01
31	33	0.778615E 00	31	34	0.570810E 00	31	37	0.103618E 01
31	38	0.790214E 00	31	39	0.576677E 00	31	42	0.921468E 00
31	43	0.728808E 00	31	44	0.548183E 00	31	47	0.734220E 00
31	48	0.609194E 00	31	49	0.484643E 00	31	52	0.509920E 00
31	53	0.461980E 00	31	54	0.401931E 00	31	57	0.291457E 00
31	58	0.315071E 00	31	59	0.312950E 00	31	63	0.186496E 00
31	64	0.228947E 00	31	67	0.222850E-02	31	68	0.851182E-01
31	69	0.157505E 00	31	72	-0.820552E-01	31	73	0.131412E-01
31	74	0.102030E 00	31	77	-0.130984E 00	31	78	-0.330048E-01
31	79	0.631888E-01	31	82	-0.149011E 00	31	83	-0.555159E-01
31	84	0.395702E-01	31	87	-0.146809E 00	31	88	-0.624392E-01
31	89	0.272400E-01	31	92	-0.129671E 00	31	93	-0.586567E-01
31	94	0.235192E-01	31	97	-0.112016E 00	31	98	-0.517635E-01
31	99	0.260246E-01	31	103	-0.437999E-01	31	104	0.337459E-01
31	107	-0.107620E 00	31	108	-0.332524E-01	31	109	0.474577E-01
31	112	-0.936406E-01	31	113	-0.131448E-01	31	114	0.693766E-01
31	117	-0.585779E-01	31	118	0.233106E-01	31	119	0.102553E 00
32	2	0.644722E-01	32	3	0.128088E 00	32	4	0.187267E 00
32	7	0.141646E 00	32	8	0.194671E 00	32	9	0.239039E 00
32	12	0.243090E 00	32	13	0.282581E 00	32	14	0.302069E 00
32	17	0.380617E 00	32	18	0.391945E 00	32	19	0.372869E 00
32	23	0.515002E 00	32	24	0.443601E 00	32	27	0.765832E 00
32	28	0.631725E 00	32	29	0.502346E 00	32	32	0.889278E 00
32	33	0.710564E 00	32	34	0.536054E 00	32	37	0.893579E 00
32	38	0.709300E 00	32	39	0.541736E 00	32	42	0.794403E 00
32	43	0.654037E 00	32	44	0.515909E 00	32	47	0.644721E 00
32	48	0.553152E 00	32	49	0.461190E 00	32	52	0.459384E 00
32	53	0.430858E 00	32	54	0.391166E 00	32	57	0.278916E 00
32	58	0.309184E 00	32	59	0.316543E 00	32	63	0.203407E 00
32	64	0.246425E 00	32	67	0.457453E-01	32	68	0.120481E 00
32	69	0.186917E 00	32	72	-0.219764E-01	32	73	0.615977E-01
32	74	0.140661E 00	32	77	-0.621677E-01	32	78	0.233184E-01
32	79	0.108107E 00	32	82	-0.782583E-01	32	83	0.405570E-02
32	84	0.882764E-01	32	87	-0.788634E-01	32	88	-0.284070E-02
32	89	0.777578E-01	32	92	-0.672641E-01	32	93	-0.356800E-03
32	94	0.748333E-01	32	97	-0.530798E-01	32	98	0.613310E-02
32	99	0.777652E-01	32	103	0.153234E-01	32	104	0.857471E-01
32	107	-0.381978E-01	32	108	0.278603E-01	32	109	0.991691E-01
32	112	-0.206143E-01	32	113	0.482563E-01	32	114	0.119432E 00
32	117	0.120511E-01	32	118	0.809104E-01	32	119	0.148596E 00
33	2	0.132146E 00	33	3	0.184558E 00	33	4	0.235056E 00
33	7	0.186047E 00	33	8	0.233568E 00	33	9	0.275379E 00
33	12	0.253848E 00	33	13	0.297183E 00	33	14	0.324051E 00
33	17	0.347781E 00	33	18	0.377428E 00	33	19	0.379299E 00
33	23	0.468810E 00	33	24	0.436921E 00	33	27	0.618587E 00

33	28	0.573467E 00	33	29	0.485959E 00	33	32	0.716813E 00
33	33	0.623254E 00	33	34	0.521134E 00	33	37	0.717435E 00
33	38	0.632043E 00	33	39	0.514501E 00	33	42	0.656658E 00
33	43	0.571854E 00	33	44	0.488737E 00	33	47	0.544443E 00
33	48	0.493774E 00	33	49	0.441063E 00	33	52	0.403691E 00
33	53	0.398631E 00	33	54	0.384198E 00	33	57	0.265610E 00
33	58	0.305114E 00	33	59	0.325042E 00	33	63	0.224871E 00
33	64	0.270187E 00	33	67	0.959008E-01	33	68	0.162776E 00
33	69	0.223941E 00	33	72	0.472378E-01	33	73	0.118810E 00
33	74	0.188017E 00	33	77	0.173111E-01	33	78	0.895987E-01
33	79	0.162556E 00	33	82	0.384290E-02	33	83	0.742204E-01
33	84	0.147007E 00	33	87	0.109200E-03	33	88	0.673540E-01
33	89	0.138490E 00	33	92	0.525850E-02	33	93	0.682510E-01
33	94	0.136384E 00	33	97	0.151532E-01	33	98	0.740651E-01
33	99	0.139683E 00	33	102	0.843681E-01	33	104	0.147831E 00
33	107	0.410431E-01	33	108	0.988584E-01	33	109	0.160813E 00
33	112	0.622390E-01	33	113	0.119319E 00	33	114	0.179149E 00
33	117	0.7908E-01	33	118	0.147507E 00	33	119	0.203829E 00
34	2	0.193542E 00	34	3	0.237530E 00	34	4	0.282515E 00
34	7	0.224486E 00	34	8	0.269018E 00	34	9	0.311609E 00
34	12	0.259989E 00	34	13	0.308760E 00	34	14	0.346319E 00
34	17	0.312296E 00	34	18	0.359625E 00	34	19	0.386549E 00
34	23	0.420602E 00	34	24	0.430877E 00	34	27	0.482157E 00
34	28	0.479844E 00	34	29	0.482801E 00	34	32	0.536416E 00
34	33	0.525858E 00	34	34	0.481672E 00	34	37	0.552198E 00
34	38	0.520349E 00	34	39	0.501342E 00	34	42	0.520236E 00
34	43	0.490884E 00	34	44	0.464199E 00	34	47	0.446964E 00
34	48	0.435188E 00	34	49	0.424547E 00	34	52	0.349329E 00
34	53	0.368263E 00	34	54	0.380845E 00	34	57	0.253344E 00
34	58	0.302956E 00	34	59	0.337088E 00	34	63	0.248397E 00
34	64	0.297365E 00	34	67	0.147453E 00	34	68	0.207329E 00
34	69	0.264279E 00	34	72	0.118357E 00	34	73	0.178505E 00
34	74	0.238596E 00	34	77	0.991061E-01	34	78	0.158497E 00
34	79	0.220107E 00	34	82	0.882365E-01	34	83	0.146834E 00
34	84	0.208539E 00	34	87	0.811087E-01	34	88	0.139714E 00
34	89	0.201735E 00	34	92	0.790614E-01	34	93	0.138432E 00
34	94	0.200016E 00	34	97	0.834659E-01	34	98	0.142697E 00
34	99	0.203130E 00	34	103	0.153048E 00	34	104	0.210824E 00
34	107	0.117160E 00	34	108	0.168354E 00	34	109	0.222763E 00
34	112	0.140410E 00	34	113	0.187854E 00	34	114	0.238679E 00
34	117	0.165672E 00	34	118	0.210833E 00	34	119	0.258596E 00
35	2	0.245840E 00	35	3	0.284166E 00	35	4	0.326902E 00
35	7	0.253878E 00	35	8	0.297685E 00	35	9	0.344329E 00
35	12	0.258851E 00	35	13	0.313372E 00	35	14	0.364220E 00
35	17	0.273399E 00	35	18	0.334833E 00	35	19	0.386769E 00
35	23	0.362345E 00	35	24	0.410463E 00	35	27	0.362026E 00
35	28	0.390129E 00	35	29	0.429769E 00	35	32	0.396378E 00
35	33	0.407321E 00	35	34	0.449952E 00	35	37	0.406273E 00
35	38	0.414242E 00	35	39	0.439463E 00	35	42	0.391660E 00
35	43	0.402661E 00	35	44	0.427288E 00	35	47	0.351460E 00
35	48	0.373839E 00	35	49	0.404007E 00	35	52	0.295001E 00
35	53	0.336527E 00	35	54	0.376955E 00	35	57	0.240843E 00
35	58	0.300581E 00	35	59	0.350046E 00	35	63	0.272623E 00
35	64	0.326182E 00	35	67	0.200229E 00	35	68	0.253391E 00
35	69	0.306674E 00	35	72	0.191710E 00	35	73	0.240369E 00
35	74	0.291474E 00	35	77	0.183872E 00	35	78	0.229977E 00
35	79	0.280033E 00	35	82	0.175907E 00	35	83	0.222166E 00

35	84	0.272414E 00	35	87	0.164980E 00	35	88	0.214416E 00
35	89	0.266975E 00	35	92	0.154699E 00	35	93	0.210160E 00
35	94	0.265087E 00	35	97	0.152025E 00	35	98	0.211730E 00
35	99	0.267284E 00	35	103	0.220731E 00	35	104	0.273681E 00
35	107	0.189408E 00	35	108	0.235323E 00	35	109	0.283709E 00
35	112	0.212568E 00	35	113	0.252378E 00	35	114	0.296404E 00
35	117	0.231705E 00	35	118	0.268861E 00	35	119	0.310897E 00
36	2	-0.517434E-01	36	3	0.387444E-01	36	4	0.123188E 00
36	7	0.434798E-01	36	8	0.119499E 00	36	9	0.184991E 00
36	12	0.176358E 00	36	13	0.230482E 00	36	14	0.263226E 00
36	17	0.356206E 00	36	18	0.370169E 00	36	19	0.353807E 00
36	23	0.528569E 00	36	24	0.447757E 00	36	27	0.839143E 00
36	28	0.684647E 00	36	29	0.531537E 00	36	32	0.104078E 01
36	33	0.801652E 00	36	34	0.590641E 00	36	37	0.113734E 01
36	38	0.845480E 00	36	39	0.613370E 00	36	42	0.105771E 01
36	43	0.811014E 00	36	44	0.596139E 00	36	47	0.863333E 00
36	48	0.697883E 00	36	49	0.539163E 00	36	52	0.614438E 00
36	53	0.542159E 00	36	54	0.456420E 00	36	57	0.368336E 00
36	58	0.381428E 00	36	59	0.362503E 00	36	63	0.238823E 00
36	64	0.271170E 00	36	67	0.460252E-01	36	68	0.125429E 00
36	69	0.191835E 00	36	72	-0.499596E-01	36	73	0.434122E-01
36	74	0.128836E 00	36	77	-0.108834E 00	36	78	-0.114985E-01
36	79	0.831351E-01	36	82	-0.135513E 00	36	83	-0.415755E-01
36	84	0.535489E-01	36	87	-0.141181E 00	36	88	-0.556147E-01
36	89	0.353448E-01	36	92	-0.131526E 00	36	93	-0.587862E-01
36	94	0.259670E-01	36	97	-0.122167E 00	36	98	-0.591443E-01
36	99	0.228801E-01	36	103	-0.588953E-01	36	104	0.250745E-01
36	107	-0.138904E 00	36	108	-0.563226E-01	36	109	0.334936E-01
36	112	-0.135189E 00	36	113	-0.436578E-01	36	114	0.506556E-01
36	117	-0.108804E 00	36	118	-0.133600E-01	36	119	0.800509E-01
37	2	0.113300E-01	37	3	0.886896E-01	37	4	0.162006E 00
37	7	0.871829E-01	37	8	0.154221E 00	37	9	0.213238E 00
37	12	0.191327E 00	37	13	0.243657E 00	37	14	0.277744E 00
37	17	0.333572E 00	37	18	0.356665E 00	37	19	0.352497E 00
37	23	0.485868E 00	37	24	0.430540E 00	37	27	0.722637E 00
37	28	0.615251E 00	37	29	0.500932E 00	37	32	0.893584E 00
37	33	0.715746E 00	37	34	0.551100E 00	37	37	0.966008E 00
37	38	0.762594E 00	37	39	0.568392E 00	37	42	0.907790E 00
37	43	0.723621E 00	37	44	0.555643E 00	37	47	0.742996E 00
37	48	0.626260E 00	37	49	0.507059E 00	37	52	0.543188E 00
37	53	0.496719E 00	37	54	0.437338E 00	37	57	0.342484E 00
37	58	0.365157E 00	37	59	0.359084E 00	37	63	0.249266E 00
37	64	0.283528E 00	37	67	0.869418E-01	37	68	0.157637E 00
37	69	0.218013E 00	37	72	0.107389E-01	37	73	0.911502E-01
37	74	0.165800E 00	37	77	-0.374200E-01	37	78	0.456997E-01
37	79	0.127487E 00	37	82	-0.612429E-01	37	83	0.196764E-01
37	84	0.102272E 00	37	87	-0.698460E-01	37	88	0.577270E-02
37	89	0.860985E-01	37	92	-0.665025E-01	37	93	0.968800E-03
37	94	0.774500E-01	37	97	-0.615324E-01	37	98	-0.274300E-03
37	99	0.745708E-01	37	103	0.792700E-03	37	104	0.767798E-01
37	107	-0.684864E-01	37	108	0.517000E-02	37	109	0.847281E-01
37	112	-0.609298E-01	37	113	0.182099E-01	37	114	0.100162E 00
37	117	-0.362593E-01	37	118	0.450458E-01	37	119	0.125574E 00
38	2	0.828568E-01	38	3	0.146749E 00	38	4	0.208969E 00
38	7	0.136735E 00	38	8	0.195150E 00	38	9	0.248506E 00
38	12	0.208584E 00	38	13	0.260516E 00	38	14	0.297950E 00
38	17	0.308773E 00	38	18	0.343790E 00	38	19	0.355581E 00

38	23	0.440870E 00	38	24	0.416858E 00	38	27	0.595893E 00
38	28	0.538613E 00	38	29	0.474980E 00	38	32	0.711043E 00
38	33	0.632096E 00	38	34	0.518187E 00	38	37	0.768925E 00
38	38	0.657870E 00	38	39	0.541534E 00	38	42	0.722226E 00
38	43	0.638341E 00	38	44	0.521664E 00	38	47	0.612404E 00
38	48	0.547125E 00	38	49	0.479485E 00	38	52	0.463200E 00
38	53	0.448884E 00	38	54	0.421612E 00	38	57	0.314352E 00
38	58	0.349292E 00	38	59	0.359902E 00	38	63	0.263206E 00
38	64	0.301419E 00	38	67	0.133531E 00	38	68	0.195893E 00
38	69	0.251071E 00	38	72	0.797895E-01	38	73	0.146887E 00
38	74	0.210791E 00	38	77	0.440155E-01	38	78	0.112196E 00
38	79	0.180710E 00	38	82	0.237368E-01	38	83	0.908929E-01
38	84	0.160405E 00	38	87	0.120698E-01	38	88	0.772665E-01
38	89	0.146527E 00	38	92	0.839540E-02	38	93	0.706884E-01
38	94	0.138705E 00	38	97	0.838200E-02	38	98	0.684412E-01
38	99	0.136047E 00	38	103	0.703654E-01	38	104	0.138241E 00
38	107	0.122104E-01	38	108	0.766537E-01	38	109	0.145616E 00
38	112	0.238186E-01	38	113	0.899543E-01	38	114	0.159068E 00
38	117	0.462134E-01	38	118	0.112722E 00	38	119	0.179991E 00
39	2	0.152607E 00	39	3	0.204984E 00	39	4	0.258295E 00
39	7	0.184502E 00	39	8	0.236311E 00	39	9	0.286406E 00
39	12	0.224670E 00	39	13	0.277922E 00	39	14	0.321224E 00
39	17	0.283949E 00	39	18	0.332008E 00	39	19	0.362236E 00
39	23	0.396774E 00	39	24	0.407254E 00	39	27	0.471559E 00
39	28	0.464041E 00	39	29	0.452739E 00	39	32	0.542838E 00
39	33	0.516706E 00	39	34	0.501353E 00	39	37	0.568759E 00
39	38	0.546237E 00	39	39	0.492664E 00	39	42	0.551307E 00
39	43	0.521439E 00	39	44	0.503886E 00	39	47	0.484128E 00
39	48	0.470258E 00	39	49	0.455779E 00	39	52	0.385952E 00
39	53	0.402148E 00	39	54	0.410182E 00	39	57	0.286635E 00
39	58	0.334877E 00	39	59	0.364535E 00	39	63	0.278075E 00
39	64	0.322654E 00	39	67	0.178774E 00	39	68	0.234761E 00
39	69	0.287048E 00	39	72	0.147523E 00	39	73	0.203173E 00
39	74	0.258423E 00	39	77	0.124540E 00	39	78	0.179403E 00
39	79	0.236452E 00	39	82	0.108281E 00	39	83	0.163005E 00
39	84	0.220950E 00	39	87	0.940832E-01	39	88	0.149929E 00
39	89	0.209395E 00	39	92	0.837451E-01	39	93	0.141764E 00
39	94	0.202424E 00	39	97	0.788184E-01	39	98	0.138541E 00
39	99	0.199977E 00	39	103	0.141187E 00	39	104	0.202097E 00
39	107	0.927401E-01	39	108	0.149105E 00	39	109	0.208808E 00
39	112	0.107782E 00	39	113	0.162320E 00	39	114	0.220196E 00
39	117	0.127276E 00	39	118	0.180706E 00	39	119	0.236621E 00
40	2	0.219204E 00	40	3	0.261767E 00	40	4	0.308149E 00
40	7	0.228878E 00	40	8	0.275761E 00	40	9	0.324788E 00
40	12	0.237983E 00	40	13	0.293562E 00	40	14	0.344821E 00
40	17	0.258131E 00	40	18	0.318421E 00	40	19	0.368474E 00
40	23	0.350694E 00	40	24	0.394550E 00	40	27	0.357387E 00
40	28	0.384265E 00	40	29	0.419867E 00	40	32	0.396824E 00
40	33	0.409611E 00	40	34	0.438033E 00	40	37	0.413582E 00
40	38	0.417210E 00	40	39	0.454440E 00	40	42	0.402988E 00
40	43	0.412956E 00	40	44	0.439687E 00	40	47	0.366310E 00
40	48	0.388405E 00	40	49	0.421595E 00	40	52	0.311716E 00
40	53	0.353769E 00	40	54	0.395889E 00	40	57	0.258568E 00
40	58	0.319085E 00	40	59	0.369066E 00	40	63	0.291715E 00
40	64	0.344580E 00	40	67	0.221335E 00	40	68	0.272494E 00
40	69	0.323909E 00	40	72	0.212872E 00	40	73	0.258595E 00
40	74	0.306985E 00	40	77	0.203364E 00	40	78	0.246153E 00

40	79	0.293179E 00	40	82	0.192073E 00	40	83	0.235250E 00
40	84	0.282692E 00	40	87	0.176027E 00	40	88	0.223120E 00
40	89	0.273567E 00	40	92	0.159429E 00	40	93	0.213601E 00
40	94	0.267509E 00	40	97	0.149638E 00	40	98	0.209424E 00
40	99	0.265257E 00	40	103	0.212602E 00	40	104	0.267207E 00
40	107	0.172776E 00	40	108	0.221769E 00	40	109	0.273096E 00
40	112	0.190429E 00	40	113	0.234390E 00	40	114	0.282234E 00
40	117	0.206112E 00	40	118	0.247849E 00	40	119	0.293995E 00
41	2	-0.846356E-01	41	3	0.957600E-02	41	4	0.990010E-01
41	7	-0.387400E-03	41	8	0.811428E-01	41	9	0.154036E 00
41	12	0.120308E 00	41	13	0.181703E 00	41	14	0.225383E 00
41	17	0.284515E 00	41	18	0.309550E 00	41	19	0.309817E 00
41	23	0.456667E 00	41	24	0.400006E 00	41	27	0.724438E 00
41	28	0.606206E 00	41	29	0.484796E 00	41	32	0.920025E 00
41	33	0.730940E 00	41	34	0.551130E 00	41	37	0.105250E 01
41	38	0.803039E 00	41	39	0.586194E 00	41	42	0.107266E 01
41	43	0.799636E 00	41	44	0.584928E 00	41	47	0.920932E 00
41	48	0.719361E 00	41	49	0.543192E 00	41	52	0.677430E 00
41	53	0.580111E 00	41	54	0.473061E 00	41	57	0.427998E 00
41	58	0.425281E 00	41	59	0.387111E 00	41	63	0.284368E 00
41	64	0.299580E 00	41	67	0.106341E 00	41	68	0.170763E 00
41	69	0.221113E 00	41	72	0.726290E-02	41	73	0.864217E-01
41	74	0.156899E 00	41	77	-0.579078E-01	41	78	0.268961E-01
41	79	0.108347E 00	41	82	-0.932715E-01	41	83	-0.941890E-02
41	84	0.749686E-01	41	87	-0.109354E 00	41	88	-0.311298E-01
41	89	0.517473E-01	41	92	-0.110796E 00	41	93	-0.425200E-01
41	94	0.368710E-01	41	97	-0.112066E 00	41	98	-0.508742E-01
41	99	0.280908E-01	41	103	-0.581646E-01	41	104	0.245805E-01
41	107	-0.145783E 00	41	108	-0.627563E-01	41	109	0.273116E-01
41	112	-0.150078E 00	41	113	-0.572214E-01	41	114	0.386942E-01
41	117	-0.132256E 00	41	118	-0.344763E-01	41	119	0.620751E-01
42	2	-0.225200E-01	42	3	0.595632E-01	42	4	0.138531E 00
42	7	0.453412E-01	42	8	0.118093E 00	42	9	0.184349E 00
42	12	0.141428E 00	42	13	0.200028E 00	42	14	0.243600E 00
42	17	0.273392E 00	42	18	0.304639E 00	42	19	0.313817E 00
42	23	0.425850E 00	42	24	0.389162E 00	42	27	0.634792E 00
42	28	0.549657E 00	42	29	0.460649E 00	42	32	0.791606E 00
42	33	0.654587E 00	42	34	0.517502E 00	42	37	0.905541E 00
42	38	0.718560E 00	42	39	0.548540E 00	42	42	0.914867E 00
42	43	0.726832E 00	42	44	0.546660E 00	42	47	0.797007E 00
42	48	0.650260E 00	42	49	0.514119E 00	42	52	0.592037E 00
42	53	0.532163E 00	42	54	0.455307E 00	42	57	0.393520E 00
42	58	0.404731E 00	42	59	0.383616E 00	42	63	0.291061E 00
42	64	0.311213E 00	42	67	0.142126E 00	42	68	0.199998E 00
42	69	0.246523E 00	42	72	0.643944E-01	42	73	0.132020E 00
42	74	0.193292E 00	42	77	0.112466E-01	42	78	0.826873E-01
42	79	0.152366E 00	42	82	-0.204174E-01	42	83	0.508913E-01
42	84	0.123458E 00	42	87	-0.390803E-01	42	88	0.295036E-01
42	89	0.102283E 00	42	92	-0.469420E-01	42	93	0.163663E-01
42	94	0.880132E-01	42	97	-0.531046E-01	42	98	0.676800E-02
42	99	0.792261E-01	42	103	-0.156300E-03	42	104	0.755141E-01
42	107	-0.785506E-01	42	108	-0.328250E-02	42	109	0.776787E-01
42	112	-0.791999E-01	42	113	0.267090E-02	42	114	0.874864E-01
42	117	-0.624296E-01	42	118	0.226021E-01	42	119	0.107398E 00
43	2	0.495909E-01	43	3	0.118817E 00	43	4	0.186946E 00
43	7	0.985150E-01	43	8	0.162433E 00	43	9	0.222397E 00
43	12	0.166431E 00	43	13	0.223209E 00	43	14	0.268120E 00

43	17	0.261758E	00	43	18	0.301592E	00	43	19	0.322580E	00
43	23	0.393685E	00	43	24	0.381752E	00	43	27	0.533798E	00
43	28	0.489114E	00	43	29	0.439232E	00	43	32	0.651276E	00
43	33	0.569775E	00	43	34	0.488135E	00	43	37	0.722581E	00
43	38	0.636140E	00	43	39	0.517654E	00	43	42	0.733153E	00
43	43	0.633453E	00	43	44	0.527342E	00	43	47	0.640583E	00
43	48	0.585456E	00	43	49	0.492889E	00	43	52	0.500397E	00
43	53	0.479377E	00	43	54	0.443657E	00	43	57	0.354394E	00
43	58	0.384390E	00	43	59	0.385091E	00	43	63	0.300400E	00
43	64	0.328520E	00	43	67	0.181858E	00	43	68	0.234282E	00
43	69	0.278585E	00	43	72	0.128060E	00	43	73	0.184484E	00
43	74	0.237297E	00	43	77	0.886565E-01		43	78	0.146643E	00
43	79	0.204766E	00	43	82	0.617763E-01		43	83	0.120315E	00
43	84	0.181043E	00	43	87	0.407719E-01		43	88	0.996339E-01	
43	89	0.162293E	00	43	92	0.262389E-01		43	93	0.849160E-01	
43	94	0.148889E	00	43	97	0.150778E-01		43	98	0.742919E-01	
43	99	0.140298E	00	43	103	0.681109E-01		43	104	0.136551E	00
43	107	-0.187200E-03		43	108	0.668701E-01		43	109	0.138228E	00
43	112	0.338740E-02		43	113	0.733930E-01		43	114	0.146361E	00
43	117	0.188301E-01		43	118	0.901087E-01		43	119	0.162414E	00
44	2	0.122609E	00	44	3	0.180017E	00	44	4	0.238517E	00
44	7	0.152330E	00	44	8	0.208665E	00	44	9	0.263798E	00
44	12	0.192079E	00	44	13	0.248361E	00	44	14	0.296278E	00
44	17	0.251205E	00	44	18	0.300746E	00	44	19	0.335357E	00
44	23	0.364123E	00	44	24	0.378708E	00	44	27	0.437135E	00
44	28	0.430604E	00	44	29	0.422466E	00	44	32	0.514346E	00
44	33	0.487871E	00	44	34	0.462700E	00	44	37	0.554866E	00
44	38	0.522284E	00	44	39	0.502648E	00	44	42	0.547042E	00
44	43	0.532068E	00	44	44	0.485113E	00	44	47	0.496698E	00
44	48	0.487344E	00	44	49	0.486589E	00	44	52	0.408418E	00
44	53	0.426824E	00	44	54	0.434335E	00	44	57	0.315120E	00
44	58	0.362787E	00	44	59	0.389130E	00	44	63	0.308674E	00
44	64	0.347808E	00	44	67	0.217568E	00	44	68	0.266938E	00
44	69	0.312149E	00	44	72	0.187367E	00	44	73	0.235158E	00
44	74	0.282463E	00	44	77	0.162085E	00	44	78	0.209025E	00
44	79	0.258236E	00	44	82	0.140575E	00	44	83	0.188406E	00
44	84	0.239538E	00	44	87	0.118416E	00	44	88	0.169163E	00
44	89	0.223496E	00	44	92	0.984733E-01		44	93	0.153674E	00
44	94	0.211333E	00	44	97	0.834027E-01		44	98	0.142751E	00
44	99	0.203330E	00	44	103	0.137869E	00	44	104	0.199889E	00
44	107	0.794625E-01		44	108	0.138842E	00	44	109	0.201338E	00
44	112	0.872926E-01		44	113	0.146040E	00	44	114	0.207968E	00
44	117	0.101145E	00	44	118	0.159477E	00	44	119	0.220277E	00
45	2	0.197353E	00	45	3	0.243168E	00	45	4	0.292471E	00
45	7	0.207021E	00	45	8	0.256297E	00	45	9	0.307420E	00
45	12	0.217858E	00	45	13	0.274268E	00	45	14	0.326364E	00
45	17	0.240467E	00	45	18	0.299984E	00	45	19	0.349496E	00
45	23	0.333798E	00	45	24	0.375765E	00	45	27	0.343530E	00
45	28	0.370236E	00	45	29	0.402513E	00	45	32	0.386504E	00
45	33	0.399904E	00	45	34	0.425913E	00	45	37	0.407306E	00
45	38	0.414926E	00	45	39	0.439848E	00	45	42	0.403420E	00
45	43	0.411172E	00	45	44	0.451832E	00	45	47	0.371732E	00
45	48	0.394688E	00	45	49	0.431659E	00	45	52	0.322269E	00
45	53	0.365643E	00	45	54	0.411871E	00	45	57	0.273825E	00
45	58	0.335465E	00	45	59	0.387326E	00	45	63	0.311256E	00
45	64	0.363851E	00	45	67	0.245568E	00	45	68	0.294019E	00
45	69	0.343263E	00	45	72	0.238856E	00	45	73	0.280611E	00

45	74	0.325534E 00	45	77	0.228599E 00	45	78	0.266944E 00
45	79	0.309980E 00	45	82	0.214081E 00	45	83	0.253168E 00
45	84	0.296868E 00	45	87	0.192696E 00	45	88	0.236679E 00
45	89	0.284217E 00	45	92	0.169277E 00	45	93	0.221765E 00
45	94	0.274037E 00	45	97	0.152001E 00	45	98	0.211753E 00
45	99	0.267340E 00	45	103	0.209144E 00	45	104	0.264828E 00
45	107	0.161573E 00	45	108	0.212990E 00	45	109	0.266520E 00
45	112	0.173965E 00	45	113	0.221162E 00	45	114	0.271943E 00
45	117	0.185999E 00	45	118	0.231273E 00	45	119	0.280636E 00
46	2	-0.990897E-01	46	3	-0.103406E-01	46	4	0.152501E-01
46	7	-0.317339E-01	46	8	0.464922E-01	46	9	0.118767E 00
46	12	0.669814E-01	46	13	0.128072E 00	46	14	0.176646E 00
46	17	0.201268E 00	46	18	0.232484E 00	46	19	0.246476E 00
46	23	0.353808E 00	46	24	0.322799E 00	46	27	0.558399E 00
46	28	0.479697E 00	46	29	0.397404E 00	46	32	0.723903E 00
46	33	0.590904E 00	46	34	0.460623E 00	46	37	0.848723E 00
46	38	0.669274E 00	46	39	0.502002E 00	46	42	0.910141E 00
46	43	0.697301E 00	46	44	0.514680E 00	46	47	0.871386E 00
46	48	0.657718E 00	46	49	0.495103E 00	46	52	0.687388E 00
46	53	0.564122E 00	46	54	0.447851E 00	46	57	0.465850E 00
46	58	0.441211E 00	46	59	0.383300E 00	46	63	0.321108E 00
46	64	0.312437E 00	46	67	0.184660E 00	46	68	0.221485E 00
46	69	0.245147E 00	46	72	0.930599E-01	46	73	0.144143E 00
46	74	0.187167E 00	46	77	0.262003E-01	46	78	0.850276E-01
46	79	0.140445E 00	46	82	-0.181698E-01	46	83	0.436807E-01
46	84	0.105422E 00	46	87	-0.481101E-01	46	88	0.132133E-01
46	89	0.778227E-01	46	92	-0.658900E-01	46	93	-0.871160E-02
46	94	0.570759E-01	46	97	-0.821767E-01	46	98	-0.271627E-01
46	99	0.417932E-01	46	103	-0.432234E-01	46	104	0.316806E-01
46	107	-0.132779E 00	46	108	-0.553552E-01	46	109	0.277778E-01
46	112	-0.144033E 00	46	113	-0.572963E-01	46	114	0.321458E-01
46	117	-0.134845E 00	46	118	-0.433985E-01	46	119	0.475532E-01
47	2	-0.405373E-01	47	3	0.391690E-01	47	4	0.116980E 00
47	7	0.145049E-01	47	8	0.862729E-01	47	9	0.153648E 00
47	12	0.945746E-01	47	13	0.153925E 00	47	14	0.202498E 00
47	17	0.204787E 00	47	18	0.241061E 00	47	19	0.261614E 00
47	23	0.343053E 00	47	24	0.326518E 00	47	27	0.504797E 00
47	28	0.449313E 00	47	29	0.390366E 00	47	32	0.642827E 00
47	33	0.543180E 00	47	34	0.445200E 00	47	37	0.741476E 00
47	38	0.610664E 00	47	39	0.482281E 00	47	42	0.796862E 00
47	43	0.638727E 00	47	44	0.495471E 00	47	47	0.757089E 00
47	48	0.617065E 00	47	49	0.478705E 00	47	52	0.612188E 00
47	53	0.529746E 00	47	54	0.441886E 00	47	57	0.426154E 00
47	58	0.425696E 00	47	59	0.387894E 00	47	63	0.327721E 00
47	64	0.328656E 00	47	67	0.212299E 00	47	68	0.248080E 00
47	69	0.272634E 00	47	72	0.141386E 00	47	73	0.185763E 00
47	74	0.224087E 00	47	77	0.869411E-01	47	78	0.136428E 00
47	79	0.184133E 00	47	82	0.473153E-01	47	83	0.998732E-01
47	84	0.153266E 00	47	87	0.158788E-01	47	88	0.701286E-01
47	89	0.127569E 00	47	92	-0.733820E-02	47	93	0.468295E-01
47	94	0.107380E 00	47	97	-0.280841E-01	47	98	0.272435E-01
47	99	0.920606E-01	47	103	0.114121E-01	47	104	0.817462E-01
47	107	-0.717058E-01	47	108	0.556200E-03	47	109	0.774133E-01
47	112	-0.796342E-01	47	113	-0.791100E-03	47	114	0.806504E-01
47	117	-0.707904E-01	47	118	0.112403E-01	47	119	0.935400E-01
48	2	0.285107E-01	48	3	0.984301E-01	48	4	0.168020E 00
48	7	0.691079E-01	48	8	0.134262E 00	48	9	0.196905E 00

48	12	0.127482E 00	48	13	0.185865E 00	48	14	0.235521E 00
48	17	0.209946E 00	48	18	0.253234E 00	48	19	0.282593E 00
48	23	0.333321E 00	48	24	0.334826E 00	48	27	0.445210E 00
48	28	0.417450E 00	48	29	0.387057E 00	48	32	0.551266E 00
48	33	0.492414E 00	48	34	0.433361E 00	48	37	0.624905E 00
48	38	0.545640E 00	48	39	0.468270E 00	48	42	0.651790E 00
48	43	0.585284E 00	48	44	0.484999E 00	48	47	0.623301E 00
48	48	0.559123E 00	48	49	0.483434E 00	48	52	0.509624E 00
48	53	0.503239E 00	48	54	0.446055E 00	48	57	0.384659E 00
48	58	0.408663E 00	48	59	0.400758E 00	48	63	0.337059E 00
48	64	0.351734E 00	48	67	0.242414E 00	48	68	0.279056E 00
48	69	0.307218E 00	48	72	0.194451E 00	48	73	0.233318E 00
48	74	0.268599E 00	48	77	0.154022E 00	48	78	0.194891E 00
48	79	0.235937E 00	48	82	0.120233E 00	48	83	0.163977E 00
48	84	0.209720E 00	48	87	0.877747E-01	48	88	0.135435E 00
48	89	0.186278E 00	48	92	0.592436E-01	48	93	0.111122E 00
48	94	0.166957E 00	48	97	0.343248E-01	48	98	0.908406E-01
48	99	0.151896E 00	48	103	0.758271E-01	48	104	0.141659E 00
48	107	0.856000E-04	48	108	0.668564E-01	48	109	0.137098E 00
48	112	-0.372420E-02	48	113	0.664396E-01	48	114	0.139233E 00
48	117	0.474240E-02	48	118	0.764087E-01	48	119	0.149358E 00
49	2	0.101658E 00	49	3	0.161481E 00	49	4	0.222723E 00
49	7	0.126851E 00	49	8	0.185470E 00	49	9	0.243643E 00
49	12	0.162320E 00	49	13	0.220259E 00	49	14	0.271744E 00
49	17	0.215840E 00	49	18	0.267049E 00	49	19	0.306462E 00
49	23	0.324459E 00	49	24	0.345724E 00	49	27	0.385052E 00
49	28	0.385761E 00	49	29	0.385987E 00	49	32	0.459775E 00
49	33	0.440192E 00	49	34	0.423380E 00	49	37	0.506331E 00
49	38	0.479097E 00	49	39	0.454842E 00	49	42	0.515182E 00
49	43	0.495039E 00	49	44	0.486548E 00	49	47	0.479146E 00
49	48	0.488268E 00	49	49	0.461428E 00	49	52	0.413309E 00
49	53	0.438451E 00	49	54	0.461207E 00	49	57	0.337079E 00
49	58	0.386805E 00	49	59	0.412022E 00	49	63	0.340408E 00
49	64	0.373583E 00	49	67	0.264426E 00	49	68	0.304549E 00
49	69	0.340289E 00	49	72	0.239114E 00	49	73	0.275470E 00
49	74	0.311515E 00	49	77	0.213287E 00	49	78	0.248540E 00
49	79	0.286308E 00	49	82	0.186479E 00	49	83	0.224035E 00
49	84	0.264988E 00	49	87	0.155141E 00	49	88	0.198169E 00
49	89	0.244563E 00	49	92	0.123714E 00	49	93	0.174515E 00
49	94	0.227026E 00	49	97	0.969723E-01	49	98	0.155184E 00
49	99	0.213183E 00	49	103	0.142436E 00	49	104	0.203905E 00
49	107	0.756385E-01	49	108	0.136458E 00	49	109	0.199824E 00
49	112	0.768014E-01	49	113	0.137633E 00	49	114	0.201334E 00
49	117	0.850350E-01	49	118	0.145730E 00	49	119	0.208919E 00
50	2	0.180700E 00	50	3	0.228746E 00	50	4	0.280142E 00
50	7	0.188951E 00	50	8	0.239875E 00	50	9	0.292623E 00
50	12	0.199397E 00	50	13	0.256358E 00	50	14	0.309429E 00
50	17	0.221661E 00	50	18	0.280786E 00	50	19	0.330733E 00
50	23	0.313581E 00	50	24	0.355600E 00	50	27	0.321958E 00
50	28	0.349851E 00	50	29	0.381737E 00	50	32	0.365883E 00
50	33	0.381378E 00	50	34	0.406041E 00	50	37	0.390088E 00
50	38	0.400575E 00	50	39	0.425083E 00	50	42	0.391155E 00
50	43	0.404761E 00	50	44	0.434794E 00	50	47	0.368034E 00
50	48	0.390105E 00	50	49	0.442189E 00	50	52	0.325804E 00
50	53	0.370828E 00	50	54	0.421249E 00	50	57	0.285489E 00
50	58	0.348130E 00	50	59	0.403628E 00	50	63	0.330152E 00
50	64	0.383299E 00	50	67	0.271916E 00	50	68	0.317129E 00

50	69	0.364267E 00	50	72	0.268837E 00	50	73	0.305771E 00
50	74	0.346762E 00	50	77	0.258936E 00	50	78	0.291855E 00
50	79	0.330149E 00	50	82	0.241699E 00	50	83	0.275753E 00
50	84	0.314879E 00	50	87	0.214888E 00	50	88	0.255030E 00
50	89	0.298921E 00	50	92	0.184238E 00	50	93	0.234664E 00
50	94	0.284719E 00	50	97	0.159172E 00	50	98	0.218788E 00
50	99	0.273621E 00	50	103	0.210477E 00	50	104	0.266664E 00
50	107	0.155978E 00	50	108	0.209158E 00	50	109	0.264137E 00
50	112	0.163426E 00	50	113	0.212930E 00	50	114	0.265730E 00
50	117	0.171714E 00	50	118	0.219451E 00	50	119	0.271071E 00
51	2	-0.100797E 00	51	3	-0.233603E-01	51	4	0.525940E-01
51	7	-0.535556E-01	51	8	0.154982E-01	51	9	0.816236E-01
51	12	0.176256E-01	51	13	0.730709E-01	51	14	0.121965E 00
51	17	0.113628E 00	51	18	0.147090E 00	51	19	0.171860E 00
51	23	0.233644E 00	51	24	0.227729E 00	51	27	0.363345E 00
51	28	0.325071E 00	51	29	0.284424E 00	51	32	0.484504E 00
51	33	0.409960E 00	51	34	0.336029E 00	51	37	0.583690E 00
51	38	0.477929E 00	51	39	0.376048E 00	51	42	0.648726E 00
51	43	0.519372E 00	51	44	0.398959E 00	51	47	0.669019E 00
51	48	0.523747E 00	51	49	0.401171E 00	51	52	0.616606E 00
51	53	0.485049E 00	51	54	0.384329E 00	51	57	0.477849E 00
51	58	0.421834E 00	51	59	0.351203E 00	51	63	0.346661E 00
51	64	0.309059E 00	51	67	0.279815E 00	51	68	0.276609E 00
51	69	0.263887E 00	51	72	0.207196E 00	51	73	0.216500E 00
51	74	0.220158E 00	51	77	0.143939E 00	51	78	0.163387E 00
51	79	0.180314E 00	51	82	0.903768E-01	51	83	0.118357E 00
51	84	0.145909E 00	51	87	0.428988E-01	51	88	0.778885E-01
51	89	0.114475E 00	51	92	0.273880E-02	51	93	0.425423E-01
51	94	0.871636E-01	51	97	-0.342994E-01	51	98	0.109701E-01
51	99	0.640901E-01	51	103	-0.161923E-01	51	104	0.459630E-01
51	107	-0.105298E 00	51	108	-0.372660E-01	51	109	0.340957E-01
51	112	-0.123701E 00	51	113	-0.476165E-01	51	114	0.301432E-01
51	117	-0.123457E 00	51	118	-0.436881E-01	51	119	0.360482E-01
52	2	-0.475296E-01	52	3	0.253574E-01	52	4	0.976257E-01
52	7	-0.795270E-02	52	8	0.584366E-01	52	9	0.122802E 00
52	12	0.515598E-01	52	13	0.107802E 00	52	14	0.158056E 00
52	17	0.133268E 00	52	18	0.171971E 00	52	19	0.201935E 00
52	23	0.247795E 00	52	24	0.251346E 00	52	27	0.352855E 00
52	28	0.328202E 00	52	29	0.301758E 00	52	32	0.457927E 00
52	33	0.402682E 00	52	34	0.347987E 00	52	37	0.541826E 00
52	38	0.461798E 00	52	39	0.384574E 00	52	42	0.591228E 00
52	43	0.499300E 00	52	44	0.407075E 00	52	47	0.611443E 00
52	48	0.507361E 00	52	49	0.411613E 00	52	52	0.559686E 00
52	53	0.486098E 00	52	54	0.397071E 00	52	57	0.450394E 00
52	58	0.424166E 00	52	59	0.371633E 00	52	63	0.358997E 00
52	64	0.335799E 00	52	67	0.297470E 00	52	68	0.301882E 00
52	69	0.296875E 00	52	72	0.242158E 00	52	73	0.252944E 00
52	74	0.259036E 00	52	77	0.190518E 00	52	78	0.207765E 00
52	79	0.223830E 00	52	82	0.142751E 00	52	83	0.167408E 00
52	84	0.192679E 00	52	87	0.954896E-01	52	88	0.128177E 00
52	89	0.162772E 00	52	92	0.520010E-01	52	93	0.923254E-01
52	94	0.136035E 00	52	97	0.120471E-01	52	98	0.602964E-01
52	99	0.113111E 00	52	103	0.336967E-01	52	104	0.950500E-01
52	107	-0.524477E-01	52	108	0.140158E-01	52	109	0.831568E-01
52	112	-0.677518E-01	52	113	0.464890E-02	52	114	0.787883E-01
52	117	-0.670677E-01	52	118	0.789560E-02	52	119	0.834444E-01
53	2	0.159912E-01	53	3	0.842535E-01	53	4	0.153025E 00

53	7	0.464138E-01	53	8	0.110540E 00	53	9	0.173791E 00
53	12	0.921156E-01	53	13	0.150320E 00	53	14	0.203246E 00
53	17	0.157121E 00	53	18	0.203111E 00	53	19	0.240348E 00
53	23	0.266749E 00	53	24	0.282637E 00	53	27	0.342415E 00
53	28	0.334901E 00	53	29	0.326343E 00	53	32	0.429919E 00
53	33	0.397979E 00	53	34	0.367226E 00	53	37	0.496065E 00
53	38	0.448112E 00	53	39	0.401084E 00	53	42	0.531940E 00
53	43	0.478845E 00	53	44	0.425532E 00	53	47	0.530931E 00
53	48	0.502851E 00	53	49	0.435825E 00	53	52	0.492474E 00
53	53	0.476920E 00	53	54	0.436053E 00	53	57	0.405135E 00
53	58	0.440404E 00	53	59	0.407179E 00	53	63	0.375598E 00
53	64	0.375086E 00	53	67	0.318030E 00	53	68	0.333871E 00
53	69	0.340409E 00	53	72	0.281993E 00	53	73	0.296587E 00
53	74	0.307973E 00	53	77	0.243124E 00	53	78	0.259958E 00
53	79	0.277248E 00	53	82	0.201672E 00	53	83	0.224496E 00
53	84	0.249210E 00	53	87	0.154977E 00	53	88	0.186744E 00
53	89	0.220862E 00	53	92	0.108312E 00	53	93	0.150626E 00
53	94	0.194798E 00	53	97	0.657734E-01	53	98	0.118507E 00
53	99	0.172190E 00	53	103	0.930079E-01	53	104	0.154402E 00
53	107	0.100133E-01	53	108	0.753010E-01	53	109	0.142670E 00
53	112	-0.139260E-02	53	113	0.673029E-01	53	114	0.137969E 00
53	117	-0.130000E-03	53	118	0.698493E-01	53	119	0.141276E 00
54	2	0.877289E-01	54	3	0.148396E 00	54	4	0.210896E 00
54	7	0.106960E 00	54	8	0.166469E 00	54	9	0.226442E 00
54	12	0.135763E 00	54	13	0.194471E 00	54	14	0.248827E 00
54	17	0.180282E 00	54	18	0.233182E 00	54	19	0.277559E 00
54	23	0.281668E 00	54	24	0.310966E 00	54	27	0.323397E 00
54	28	0.334532E 00	54	29	0.346185E 00	54	32	0.389909E 00
54	33	0.383393E 00	54	34	0.379962E 00	54	37	0.436484E 00
54	38	0.421047E 00	54	39	0.409485E 00	54	42	0.455985E 00
54	43	0.444437E 00	54	44	0.434278E 00	54	47	0.443050E 00
54	48	0.448348E 00	54	49	0.461193E 00	54	52	0.398045E 00
54	53	0.441213E 00	54	54	0.437006E 00	54	57	0.351022E 00
54	58	0.404597E 00	54	59	0.442384E 00	54	63	0.374068E 00
54	64	0.401893E 00	54	67	0.318477E 00	54	68	0.347732E 00
54	69	0.372525E 00	54	72	0.302179E 00	54	73	0.324193E 00
54	74	0.346205E 00	54	77	0.277800E 00	54	78	0.298001E 00
54	79	0.321107E 00	54	82	0.245943E 00	54	83	0.270055E 00
54	84	0.297715E 00	54	87	0.204144E 00	54	88	0.236993E 00
54	89	0.272873E 00	54	92	0.159113E 00	54	93	0.204110E 00
54	94	0.249606E 00	54	97	0.118744E 00	54	98	0.175333E 00
54	99	0.229436E 00	54	103	0.153995E 00	54	104	0.213840E 00
54	107	0.792555E-01	54	108	0.140695E 00	54	109	0.203798E 00
54	112	0.738562E-01	54	113	0.135611E 00	54	114	0.199769E 00
54	117	0.763910E-01	54	118	0.137997E 00	54	119	0.202117E 00
55	2	0.169054E 00	55	3	0.218421E 00	55	4	0.271128E 00
55	7	0.174799E 00	55	8	0.226685E 00	55	9	0.280549E 00
55	12	0.183191E 00	55	13	0.240415E 00	55	14	0.294416E 00
55	17	0.202932E 00	55	18	0.261943E 00	55	19	0.312905E 00
55	23	0.291820E 00	55	24	0.335232E 00	55	27	0.295308E 00
55	28	0.325785E 00	55	29	0.359436E 00	55	32	0.337750E 00
55	33	0.356743E 00	55	34	0.382942E 00	55	37	0.363755E 00
55	38	0.378301E 00	55	39	0.403131E 00	55	42	0.369769E 00
55	43	0.387589E 00	55	44	0.418385E 00	55	47	0.354033E 00
55	48	0.382565E 00	55	49	0.424550E 00	55	52	0.322978E 00
55	53	0.366992E 00	55	54	0.432204E 00	55	57	0.292711E 00
55	58	0.355794E 00	55	59	0.414373E 00	55	63	0.346631E 00

55	64	0.401652E 00	55	67	0.298657E 00	55	68	0.340384E 00
55	69	0.386045E 00	55	72	0.301151E 00	55	73	0.332798E 00
55	74	0.369951E 00	55	77	0.292895E 00	55	78	0.319782E 00
55	79	0.353048E 00	55	82	0.273554E 00	55	83	0.301953E 00
55	84	0.336060E 00	55	87	0.241527E 00	55	88	0.277322E 00
55	89	0.317107E 00	55	92	0.203528E 00	55	93	0.251642E 00
55	94	0.299082E 00	55	97	0.170610E 00	55	98	0.230035E 00
55	99	0.283722E 00	55	103	0.216231E 00	55	104	0.272429E 00
55	107	0.155655E 00	55	108	0.209996E 00	55	109	0.265746E 00
55	112	0.158548E 00	55	113	0.209504E 00	55	114	0.263479E 00
55	117	0.163099E 00	55	118	0.212313E 00	55	119	0.265287E 00
56	2	-0.925590E-01	56	3	-0.307383E-01	56	4	0.310644E-01
56	7	-0.667316E-01	56	8	-0.113310E-01	56	9	0.441115E-01
56	12	-0.256449E-01	56	13	0.198122E-01	56	14	0.647882E-01
56	17	0.279669E-01	56	18	0.599103E-01	56	19	0.917913E-01
56	23	0.106790E 00	56	24	0.123258E 00	56	27	0.157472E 00
56	28	0.157272E 00	56	29	0.156989E 00	56	32	0.224505E 00
56	33	0.207629E 00	56	34	0.190737E 00	56	37	0.286985E 00
56	38	0.254535E 00	56	39	0.222145E 00	56	42	0.340457E 00
56	43	0.294723E 00	56	44	0.248965E 00	56	47	0.381805E 00
56	48	0.325477E 00	56	49	0.269495E 00	56	52	0.407197E 00
56	53	0.344493E 00	56	54	0.282247E 00	56	57	0.417003E 00
56	58	0.349926E 00	56	59	0.286541E 00	56	63	0.342535E 00
56	64	0.281885E 00	56	67	0.378406E 00	56	68	0.323517E 00
56	69	0.268691E 00	56	72	0.338448E 00	56	73	0.293100E 00
56	74	0.248069E 00	56	77	0.285302E 00	56	78	0.253279E 00
56	79	0.221243E 00	56	82	0.223293E 00	56	83	0.206631E 00
56	84	0.190000E 00	56	87	0.156726E 00	56	88	0.156610E 00
56	89	0.156453E 00	56	92	0.900590E-01	56	93	0.106412E 00
56	94	0.122904E 00	56	97	0.278870E-01	56	98	0.597484E-01
56	99	0.915823E-01	56	103	0.197907E-01	56	104	0.646819E-01
56	107	-0.665688E-01	56	108	-0.112841E-01	56	109	0.440662E-01
56	112	-0.924176E-01	56	113	-0.306834E-01	56	114	0.310462E-01
56	117	-0.101247E 00	56	118	-0.373188E-01	56	119	0.266336E-01
57	2	-0.523389E-01	57	3	0.150874E-01	57	4	0.830160E-01
57	7	-0.275972E-01	57	8	0.342767E-01	57	9	0.964321E-01
57	12	0.122042E-01	57	13	0.656928E-01	57	14	0.117946E 00
57	17	0.661610E-01	57	18	0.107173E 00	57	19	0.146349E 00
57	23	0.156732E 00	57	24	0.179716E 00	57	27	0.205581E 00
57	28	0.210516E 00	57	29	0.215576E 00	57	32	0.276548E 00
57	33	0.263606E 00	57	34	0.251337E 00	57	37	0.339605E 00
57	38	0.311758E 00	57	39	0.284372E 00	57	42	0.390182E 00
57	43	0.351386E 00	57	44	0.312378E 00	57	47	0.422614E 00
57	48	0.381368E 00	57	49	0.333901E 00	57	52	0.447222E 00
57	53	0.400938E 00	57	54	0.347414E 00	57	57	0.440330E 00
57	58	0.414295E 00	57	59	0.349850E 00	57	63	0.398023E 00
57	64	0.345991E 00	57	67	0.409787E 00	57	68	0.375174E 00
57	69	0.331681E 00	57	72	0.377651E 00	57	73	0.344993E 00
57	74	0.309647E 00	57	77	0.330975E 00	57	78	0.306360E 00
57	79	0.281667E 00	57	82	0.273744E 00	57	83	0.262102E 00
57	84	0.251210E 00	57	87	0.204986E 00	57	88	0.210098E 00
57	89	0.215805E 00	57	92	0.133403E 00	57	93	0.156964E 00
57	94	0.180234E 00	57	97	0.664161E-01	57	98	0.107583E 00
57	99	0.147005E 00	57	103	0.659798E-01	57	104	0.118585E 00
57	107	-0.281376E-01	57	108	0.343371E-01	57	109	0.969473E-01
57	112	-0.530326E-01	57	113	0.149503E-01	57	114	0.833625E-01
57	117	-0.614197E-01	57	118	0.835250E-02	57	119	0.787541E-01

58	2	0.676130E-02	58	3	0.739763E-01	58	4	0.142469E 00
58	7	0.271013E-01	58	8	0.905747E-01	58	9	0.154795E 00
58	12	0.601620E-01	58	13	0.118405E 00	58	14	0.174793E 00
58	17	0.107518E 00	58	18	0.156371E 00	58	19	0.201549E 00
58	23	0.203054E 00	58	24	0.233340E 00	58	27	0.241386E 00
58	28	0.254291E 00	58	29	0.267738E 00	58	32	0.308229E 00
58	33	0.304402E 00	58	34	0.302131E 00	58	37	0.364295E 00
58	38	0.348490E 00	58	39	0.334060E 00	58	42	0.404391E 00
58	43	0.383910E 00	58	44	0.361902E 00	58	47	0.425647E 00
58	48	0.408319E 00	58	49	0.385542E 00	58	52	0.426091E 00
58	53	0.440401E 00	58	54	0.401974E 00	58	57	0.422866E 00
58	58	0.439272E 00	58	59	0.414110E 00	58	63	0.435534E 00
58	64	0.400382E 00	58	67	0.410796E 00	58	68	0.400949E 00
58	69	0.382752E 00	58	72	0.391433E 00	58	73	0.376810E 00
58	74	0.358664E 00	58	77	0.356151E 00	58	78	0.343226E 00
58	79	0.331250E 00	58	82	0.307079E 00	58	83	0.303765E 00
58	84	0.302346E 00	58	87	0.242723E 00	58	88	0.254794E 00
58	89	0.268313E 00	58	92	0.172993E 00	58	93	0.203933E 00
58	94	0.234113E 00	58	97	0.107917E 00	58	98	0.156944E 00
58	99	0.202311E 00	58	103	0.118397E 00	58	104	0.175390E 00
58	107	0.253259E-01	58	108	0.901138E-01	58	109	0.155171E 00
58	112	0.513780E-02	58	113	0.733820E-01	58	114	0.142654E 00
58	117	-0.129870E-02	58	118	0.678610E-01	58	119	0.138483E 00
59	2	0.793154E-01	59	3	0.140152E 00	59	4	0.203247E 00
59	7	0.919771E-01	59	8	0.151765E 00	59	9	0.212958E 00
59	12	0.113072E 00	59	13	0.172178E 00	59	14	0.229036E 00
59	17	0.147135E 00	59	18	0.201763E 00	59	19	0.251053E 00
59	23	0.240029E 00	59	24	0.277759E 00	59	27	0.260196E 00
59	28	0.282934E 00	59	29	0.307054E 00	59	32	0.315653E 00
59	33	0.324480E 00	59	34	0.336559E 00	59	37	0.358444E 00
59	38	0.359495E 00	59	39	0.364151E 00	59	42	0.383926E 00
59	43	0.385457E 00	59	44	0.389053E 00	59	47	0.388655E 00
59	48	0.401668E 00	59	49	0.411986E 00	59	52	0.373306E 00
59	53	0.409789E 00	59	54	0.442363E 00	59	57	0.352747E 00
59	58	0.419245E 00	59	59	0.425789E 00	59	63	0.405879E 00
59	64	0.440997E 00	59	67	0.375823E 00	59	68	0.395498E 00
59	69	0.409684E 00	59	72	0.373095E 00	59	73	0.379591E 00
59	74	0.386416E 00	59	77	0.352599E 00	59	78	0.355691E 00
59	79	0.362102E 00	59	82	0.316252E 00	59	83	0.324725E 00
59	84	0.336950E 00	59	87	0.263327E 00	59	88	0.284203E 00
59	89	0.307727E 00	59	92	0.203098E 00	59	93	0.241308E 00
59	94	0.278482E 00	59	97	0.147452E 00	59	98	0.202224E 00
59	99	0.251594E 00	59	103	0.171624E 00	59	104	0.229273E 00
59	107	0.888433E-01	59	108	0.150602E 00	59	109	0.212912E 00
59	112	0.768172E-01	59	113	0.139022E 00	59	114	0.203034E 00
59	117	0.735744E-01	59	118	0.135462E 00	59	119	0.199840E 00
60	2	0.162634E 00	60	3	0.212467E 00	60	4	0.265725E 00
60	7	0.165002E 00	60	8	0.217207E 00	60	9	0.271651E 00
60	12	0.169997E 00	60	13	0.227209E 00	60	14	0.281974E 00
60	17	0.185524E 00	60	18	0.244625E 00	60	19	0.296904E 00
60	23	0.270194E 00	60	24	0.315846E 00	60	27	0.266215E 00
60	28	0.300306E 00	60	29	0.337190E 00	60	32	0.305173E 00
60	33	0.329008E 00	60	34	0.358817E 00	60	37	0.331224E 00
60	38	0.350930E 00	60	39	0.378686E 00	60	42	0.341301E 00
60	43	0.363978E 00	60	44	0.395801E 00	60	47	0.333529E 00
60	48	0.366104E 00	60	49	0.408701E 00	60	52	0.312512E 00
60	53	0.361956E 00	60	54	0.416047E 00	60	57	0.295703E 00

60	58	0.355807E 00	60	59	0.427553E 00	60	63	0.358865E 00
60	64	0.415006E 00	60	67	0.323378E 00	60	68	0.361373E 00
60	69	0.406947E 00	60	72	0.333148E 00	60	73	0.359591E 00
60	74	0.393832E 00	60	77	0.327983E 00	60	78	0.348847E 00
60	79	0.377591E 00	60	82	0.307596E 00	60	83	0.330236E 00
60	84	0.359491E 00	60	87	0.271008E 00	60	88	0.302324E 00
60	89	0.337994E 00	60	92	0.226014E 00	60	93	0.271777E 00
60	94	0.316496E 00	60	97	0.185579E 00	60	98	0.244836E 00
60	99	0.297167E 00	60	103	0.225951E 00	60	104	0.281783E 00
60	107	0.160250E 00	60	108	0.215195E 00	60	109	0.271124E 00
60	112	0.159072E 00	60	113	0.210697E 00	60	114	0.265082E 00
60	117	0.160002E 00	60	118	0.209798E 00	60	119	0.263297E 00
61	2	-0.118201E 00	61	3	-0.461912E-01	61	4	0.267884E-01
61	7	-0.102265E 00	61	8	-0.375249E-01	61	9	0.296769E-01
61	12	-0.723450E-01	61	13	-0.184253E-01	61	14	0.400645E-01
61	17	-0.356998E-01	61	18	0.661980E-02	61	19	0.564039E-01
61	23	0.358703E-01	61	24	0.774518E-01	61	27	0.369226E-01
61	28	0.685874E-01	61	29	0.102547E 00	61	32	0.807835E-01
61	33	0.106044E 00	61	34	0.131587E 00	61	37	0.132542E 00
61	38	0.149553E 00	61	39	0.164697E 00	61	42	0.193260E 00
61	43	0.199158E 00	61	44	0.201353E 00	61	47	0.263159E 00
61	48	0.255684E 00	61	49	0.241895E 00	61	52	0.341053E 00
61	53	0.319065E 00	61	54	0.283914E 00	61	57	0.434488E 00
61	58	0.387811E 00	61	59	0.323126E 00	61	63	0.446335E 00
61	64	0.354345E 00	61	67	0.608405E 00	61	68	0.482687E 00
61	69	0.371395E 00	61	72	0.602373E 00	61	73	0.482047E 00
61	74	0.370936E 00	61	77	0.548583E 00	61	78	0.448016E 00
61	79	0.351495E 00	61	82	0.460876E 00	61	83	0.387560E 00
61	84	0.315899E 00	61	87	0.349813E 00	61	88	0.309775E 00
61	89	0.268736E 00	61	92	0.227967E 00	61	93	0.224299E 00
61	94	0.216118E 00	61	97	0.112338E 00	61	98	0.142353E 00
61	99	0.163675E 00	61	103	0.716965E-01	61	104	0.116397E 00
61	107	-0.484930E-01	61	108	0.164117E-01	61	109	0.778236E-01
61	112	-0.940732E-01	61	113	-0.211597E-01	61	114	0.497368E-01
61	117	-0.116676E 00	61	118	-0.417747E-01	61	119	0.328259E-01
62	2	-0.653515E-01	62	3	0.552870E-02	62	4	0.777430E-01
62	7	-0.510288E-01	62	8	0.141544E-01	62	9	0.816042E-01
62	12	-0.238884E-01	62	13	0.330141E-01	62	14	0.928540E-01
62	17	0.117315E-01	62	18	0.588059E-01	62	19	0.110207E 00
62	23	0.901023E-01	62	24	0.132404E 00	62	27	0.943236E-01
62	28	0.125314E 00	62	29	0.158414E 00	62	32	0.141269E 00
62	33	0.163914E 00	62	34	0.187559E 00	62	37	0.191172E 00
62	38	0.205625E 00	62	39	0.219399E 00	62	42	0.243264E 00
62	43	0.249484E 00	62	44	0.252779E 00	62	47	0.298333E 00
62	48	0.296968E 00	62	49	0.288933E 00	62	52	0.354101E 00
62	53	0.350313E 00	62	54	0.325631E 00	62	57	0.434609E 00
62	58	0.409367E 00	62	59	0.359189E 00	62	63	0.464259E 00
62	64	0.383441E 00	62	67	0.577642E 00	62	68	0.485587E 00
62	69	0.396981E 00	62	72	0.564814E 00	62	73	0.479753E 00
62	74	0.393255E 00	62	77	0.522771E 00	62	78	0.446821E 00
62	79	0.372979E 00	62	82	0.452407E 00	62	83	0.397234E 00
62	84	0.343503E 00	62	87	0.352149E 00	62	88	0.325687E 00
62	89	0.298824E 00	62	92	0.240326E 00	62	93	0.247109E 00
62	94	0.249706E 00	62	97	0.134183E 00	62	98	0.172121E 00
62	99	0.201209E 00	62	103	0.108219E 00	62	104	0.157873E 00
62	107	-0.772610E-02	62	108	0.589435E-01	62	109	0.122872E 00
62	112	-0.469273E-01	62	113	0.259946E-01	62	114	0.977440E-01

62	117	-0.660484E-01	62	118	0.830520E-02	62	119	0.830647E-01
63	2	0.160000E-05	63	3	0.679797E-01	63	4	0.137838E 00
63	7	0.113955E-01	63	8	0.757604E-01	63	9	0.142294E 00
63	12	0.335818E-01	63	13	0.930569E-01	63	14	0.153726E 00
63	17	0.657436E-01	63	18	0.118066E 00	63	19	0.171224E 00
63	23	0.149871E 00	63	24	0.193617E 00	63	27	0.154601E 00
63	28	0.186083E 00	63	29	0.219574E 00	63	32	0.202729E 00
63	33	0.224323E 00	63	34	0.247884E 00	63	37	0.248617E 00
63	38	0.262648E 00	63	39	0.277589E 00	63	42	0.290733E 00
63	43	0.300047E 00	63	44	0.308083E 00	63	47	0.327600E 00
63	48	0.336862E 00	63	49	0.339676E 00	63	52	0.359663E 00
63	53	0.375819E 00	63	54	0.372943E 00	63	57	0.402755E 00
63	58	0.435669E 00	63	59	0.403419E 00	63	63	0.468403E 00
63	64	0.430646E 00	63	67	0.511666E 00	63	68	0.491207E 00
63	69	0.429725E 00	63	72	0.514839E 00	63	73	0.468406E 00
63	74	0.419377E 00	63	77	0.485625E 00	63	78	0.440450E 00
63	79	0.395970E 00	63	82	0.429170E 00	63	83	0.396709E 00
63	84	0.366268E 00	63	87	0.345408E 00	63	88	0.335536E 00
63	89	0.326221E 00	63	92	0.249399E 00	63	93	0.268051E 00
63	94	0.283057E 00	63	97	0.158228E 00	63	98	0.204053E 00
63	99	0.240966E 00	63	103	0.150517E 00	63	104	0.203801E 00
63	107	0.444114E-01	63	108	0.110183E 00	63	109	0.174169E 00
63	112	0.142904E-01	63	113	0.838087E-01	63	114	0.153223E 00
63	117	-0.265900E-03	63	118	0.698768E-01	63	119	0.141333E 00
64	2	0.758304E-01	64	3	0.136621E 00	64	4	0.200045E 00
64	7	0.818563E-01	64	8	0.141754E 00	64	9	0.203918E 00
64	12	0.951236E-01	64	13	0.154579E 00	64	14	0.213696E 00
64	17	0.118703E 00	64	18	0.175095E 00	64	19	0.228992E 00
64	23	0.203194E 00	64	24	0.248939E 00	64	27	0.202092E 00
64	28	0.236041E 00	64	29	0.272149E 00	64	32	0.245846E 00
64	33	0.269818E 00	64	34	0.297098E 00	64	37	0.283132E 00
64	38	0.301204E 00	64	39	0.322508E 00	64	42	0.311438E 00
64	43	0.328762E 00	64	44	0.347765E 00	64	47	0.329140E 00
64	48	0.352299E 00	64	49	0.373579E 00	64	52	0.337169E 00
64	53	0.376357E 00	64	54	0.401908E 00	64	57	0.349443E 00
64	58	0.403032E 00	64	59	0.441032E 00	64	63	0.435684E 00
64	64	0.434412E 00	64	67	0.428211E 00	64	68	0.440938E 00
64	69	0.457788E 00	64	72	0.444198E 00	64	73	0.437622E 00
64	74	0.430776E 00	64	77	0.430807E 00	64	78	0.417163E 00
64	79	0.407146E 00	64	82	0.391611E 00	64	83	0.384024E 00
64	84	0.380327E 00	64	87	0.328203E 00	64	88	0.336476E 00
64	89	0.346997E 00	64	92	0.252531E 00	64	93	0.283594E 00
64	94	0.311905E 00	64	97	0.181071E 00	64	98	0.234047E 00
64	99	0.278315E 00	64	103	0.194038E 00	64	104	0.249230E 00
64	107	0.103291E 00	64	108	0.165236E 00	64	109	0.226505E 00
64	112	0.846999E-01	64	113	0.147154E 00	64	114	0.210748E 00
64	117	0.757133E-01	64	118	0.137647E 00	64	119	0.202000E 00
65	2	0.161479E 00	65	3	0.210975E 00	65	4	0.264043E 00
65	7	0.159845E 00	65	8	0.211766E 00	65	9	0.266231E 00
65	12	0.160458E 00	65	13	0.217388E 00	65	14	0.272638E 00
65	17	0.170618E 00	65	18	0.229917E 00	65	19	0.283540E 00
65	23	0.250327E 00	65	24	0.298559E 00	65	27	0.237475E 00
65	28	0.275646E 00	65	29	0.316445E 00	65	32	0.271673E 00
65	33	0.301001E 00	65	34	0.335504E 00	65	37	0.296316E 00
65	38	0.321953E 00	65	39	0.354158E 00	65	42	0.309114E 00
65	43	0.337010E 00	65	44	0.371755E 00	65	47	0.308351E 00
65	48	0.344835E 00	65	49	0.387581E 00	65	52	0.297711E 00

65	53	0.349409E 00	65	54	0.402451E 00	65	57	0.292580E 00
65	58	0.355509E 00	65	59	0.414136E 00	65	63	0.363722E 00
65	64	0.430950E 00	65	67	0.343768E 00	65	68	0.377691E 00
65	69	0.422650E 00	65	72	0.361684E 00	65	73	0.383197E 00
65	74	0.416336E 00	65	77	0.360999E 00	65	78	0.376491E 00
65	79	0.402124E 00	65	82	0.340938E 00	65	83	0.358381E 00
65	84	0.383796E 00	65	87	0.301050E 00	65	88	0.328261E 00
65	89	0.360434E 00	65	92	0.250093E 00	65	93	0.293748E 00
65	94	0.336044E 00	65	97	0.203086E 00	65	98	0.262277E 00
65	99	0.313263E 00	65	103	0.239046E 00	65	104	0.294240E 00
65	107	0.169411E 00	65	108	0.224401E 00	65	109	0.279967E 00
65	112	0.164813E 00	65	113	0.216324E 00	65	114	0.270385E 00
65	117	0.162365E 00	65	118	0.211872E 00	65	119	0.265090E 00
66	2	-0.137273E 00	66	3	-0.537283E-01	66	4	0.313885E-01
66	7	-0.129329E 00	66	8	-0.540053E-01	66	9	0.256225E-01
66	12	-0.107442E 00	66	13	-0.441316E-01	66	14	0.277459E-01
66	17	-0.828282E-01	66	18	-0.302297E-01	66	19	0.358486E-01
66	23	-0.139730E-01	66	24	0.489819E-01	66	27	-0.519986E-01
66	28	0.550400E-02	66	29	0.675000E-01	66	32	-0.255841E-01
66	33	0.331271E-01	66	34	0.928183E-01	66	37	0.176245E-01
66	38	0.736437E-01	66	39	0.126892E 00	66	42	0.817345E-01
66	43	0.128689E 00	66	44	0.169734E 00	66	47	0.172109E 00
66	48	0.203382E 00	66	49	0.224916E 00	66	52	0.286978E 00
66	53	0.297983E 00	66	54	0.289143E 00	66	57	0.436753E 00
66	58	0.411031E 00	66	59	0.357025E 00	66	63	0.526150E 00
66	64	0.419599E 00	66	67	0.807460E 00	66	68	0.617566E 00
66	69	0.465842E 00	66	72	0.851976E 00	66	73	0.657794E 00
66	74	0.486916E 00	66	77	0.807049E 00	66	78	0.637398E 00
66	79	0.478348E 00	66	82	0.702617E 00	66	83	0.571332E 00
66	84	0.444404E 00	66	87	0.549500E 00	66	88	0.468202E 00
66	89	0.385726E 00	66	92	0.372889E 00	66	93	0.348555E 00
66	94	0.315341E 00	66	97	0.203188E 00	66	98	0.231594E 00
66	99	0.242485E 00	66	103	0.130116E 00	66	104	0.175179E 00
66	107	-0.250763E-01	66	108	0.504362E-01	66	109	0.118882E 00
66	112	-0.908117E-01	66	113	-0.531570E-02	66	114	0.760612E-01
66	117	-0.127150E 00	66	118	-0.395103E-01	66	119	0.472723E-01
67	2	-0.777119E-01	67	3	0.373400E-03	67	4	0.802678E-01
67	7	-0.710219E-01	67	8	0.826900E-03	67	9	0.764180E-01
67	12	-0.520047E-01	67	13	0.109164E-01	67	14	0.800297E-01
67	17	-0.281168E-01	67	18	0.261181E-01	67	19	0.895727E-01
67	23	0.451377E-01	67	24	0.104093E 00	67	27	0.160554E-01
67	28	0.678025E-01	67	29	0.123450E 00	67	32	0.467130E-01
67	33	0.966753E-01	67	34	0.148254E 00	67	37	0.878652E-01
67	38	0.134340E 00	67	39	0.179587E 00	67	42	0.141888E 00
67	43	0.181656E 00	67	44	0.217292E 00	67	47	0.212285E 00
67	48	0.242438E 00	67	49	0.264157E 00	67	52	0.298319E 00
67	53	0.318463E 00	67	54	0.318106E 00	67	57	0.413000E 00
67	58	0.411123E 00	67	59	0.375121E 00	67	63	0.509878E 00
67	64	0.427212E 00	67	67	0.715519E 00	67	68	0.593540E 00
67	69	0.463427E 00	67	72	0.765049E 00	67	73	0.616578E 00
67	74	0.480866E 00	67	77	0.722127E 00	67	78	0.595087E 00
67	79	0.470615E 00	67	82	0.637651E 00	67	83	0.536763E 00
67	84	0.439250E 00	67	87	0.506734E 00	67	88	0.447253E 00
67	89	0.386803E 00	67	92	0.354222E 00	67	93	0.343463E 00
67	94	0.324864E 00	67	97	0.207359E 00	67	98	0.242358E 00
67	99	0.261249E 00	67	103	0.155306E 00	67	104	0.202839E 00
67	107	0.152216E-01	67	108	0.875708E-01	67	109	0.154270E 00

67 112	-0.393581E-01	67 113	0.405590E-01	67 114	0.117587E 00
67 117	-0.695513E-01	67 118	0.118728E-01	67 119	0.932261E-01
68 2	-0.267130E-02	68 3	0.672014E-01	68 4	0.139335E 00
68 7	0.986300E-03	68 8	0.673054E-01	68 9	0.136873E 00
68 12	0.142955E-01	68 13	0.758721E-01	68 14	0.141045E 00
68 17	0.344003E-01	68 18	0.904326E-01	68 19	0.150872E 00
68 23	0.110357E 00	68 24	0.165547E 00	68 27	0.877811E-01
68 28	0.134525E 00	68 29	0.184529E 00	68 32	0.120858E 00
68 33	0.163066E 00	68 34	0.207650E 00	68 37	0.158062E 00
68 38	0.196272E 00	68 39	0.235125E 00	68 42	0.200036E 00
68 43	0.234259E 00	68 44	0.266700E 00	68 47	0.248273E 00
68 48	0.279204E 00	68 49	0.304274E 00	68 52	0.302790E 00
68 53	0.334373E 00	68 54	0.347305E 00	68 57	0.378223E 00
68 58	0.401457E 00	68 59	0.394701E 00	68 63	0.491580E 00
68 64	0.438734E 00	68 67	0.599692E 00	68 68	0.545651E 00
68 69	0.475535E 00	68 72	0.633340E 00	68 73	0.573311E 00
68 74	0.477527E 00	68 77	0.615545E 00	68 78	0.538466E 00
68 79	0.463077E 00	68 82	0.552508E 00	68 83	0.491842E 00
68 84	0.432341E 00	68 87	0.451206E 00	68 88	0.419344E 00
68 89	0.387213E 00	68 92	0.329536E 00	68 93	0.335913E 00
68 94	0.335707E 00	68 97	0.212224E 00	68 98	0.255137E 00
68 99	0.283716E 00	68 103	0.186627E 00	68 104	0.236530E 00
68 107	0.668907E-01	68 108	0.134198E 00	68 109	0.197651E 00
68 112	0.266365E-01	68 113	0.982122E-01	68 114	0.168496E 00
68 117	0.399260E-02	68 118	0.761229E-01	68 119	0.149276E 00
69 2	0.782433E-01	69 3	0.138528E 00	69 4	0.201733E 00
69 7	0.777224E-01	69 8	0.137412E 00	69 9	0.200059E 00
69 12	0.833399E-01	69 13	0.143011E 00	69 14	0.203876E 00
69 17	0.970436E-01	69 18	0.155066E 00	69 19	0.212841E 00
69 23	0.173799E 00	69 24	0.226415E 00	69 27	0.153691E 00
69 28	0.197347E 00	69 29	0.243800E 00	69 32	0.186498E 00
69 33	0.223668E 00	69 34	0.264193E 00	69 37	0.217729E 00
69 38	0.250968E 00	69 39	0.287061E 00	69 42	0.246731E 00
69 43	0.278796E 00	69 44	0.312149E 00	69 47	0.273029E 00
45 64	0.363851E 00	45 67	0.245568E 00	45 68	0.294019E 00
69 48	0.307661E 00	69 49	0.340331E 00	69 52	0.297936E 00
69 53	0.341334E 00	69 54	0.372586E 00	69 57	0.334808E 00
69 58	0.384070E 00	69 59	0.409765E 00	69 63	0.432262E 00
69 64	0.457836E 00	69 67	0.463935E 00	69 68	0.480323E 00
69 69	0.457502E 00	69 72	0.503352E 00	69 73	0.488090E 00
69 74	0.482747E 00	69 77	0.501586E 00	69 78	0.475724E 00
69 79	0.452678E 00	69 82	0.463267E 00	69 83	0.441746E 00
69 84	0.424096E 00	69 87	0.392143E 00	69 88	0.388825E 00
69 89	0.387262E 00	69 92	0.303059E 00	69 93	0.327362E 00
69 94	0.347136E 00	69 97	0.217273E 00	69 98	0.268520E 00
69 99	0.307621E 00	69 103	0.220044E 00	69 104	0.272439E 00
69 107	0.122622E 00	69 108	0.184196E 00	69 109	0.243889E 00
69 112	0.980632E-01	69 113	0.160126E 00	69 114	0.222677E 00
69 117	0.836163E-01	69 118	0.145002E 00	69 119	0.208704E 00
70 2	0.165809E 00	70 3	0.214141E 00	70 4	0.266235E 00
70 7	0.159709E 00	70 8	0.210728E 00	70 9	0.264597E 00
70 12	0.155187E 00	70 13	0.211549E 00	70 14	0.266892E 00
70 17	0.159203E 00	70 18	0.218728E 00	70 19	0.273503E 00
70 23	0.233526E 00	70 24	0.284289E 00	70 27	0.211336E 00
70 28	0.253568E 00	70 29	0.298351E 00	70 32	0.240112E 00
70 33	0.274936E 00	70 34	0.314384E 00	70 37	0.262327E 00
70 38	0.293980E 00	70 39	0.331202E 00	70 42	0.276383E 00

70	43	0.309685E 00	70	44	0.348349E 00	70	47	0.280961E 00
70	48	0.321203E 00	70	49	0.365556E 00	70	52	0.279276E 00
70	53	0.332585E 00	70	54	0.383857E 00	70	57	0.285127E 00
70	58	0.347629E 00	70	59	0.403188E 00	70	63	0.367436E 00
70	64	0.419869E 00	70	67	0.357836E 00	70	68	0.385294E 00
70	69	0.440232E 00	70	72	0.383460E 00	70	73	0.400543E 00
70	74	0.432771E 00	70	77	0.388213E 00	70	78	0.399340E 00
70	79	0.424375E 00	70	82	0.370012E 00	70	83	0.383543E 00
70	84	0.407136E 00	70	87	0.328783E 00	70	88	0.352874E 00
70	89	0.382974E 00	70	92	0.273758E 00	70	93	0.315906E 00
70	94	0.356600E 00	70	97	0.221930E 00	70	98	0.281258E 00
70	99	0.331193E 00	70	103	0.254863E 00	70	104	0.309260E 00
70	107	0.182878E 00	70	108	0.237293E 00	70	109	0.291970E 00
70	112	0.175758E 00	70	113	0.226305E 00	70	114	0.279281E 00
70	117	0.170340E 00	70	118	0.218638E 00	70	119	0.270724E 00
71	2	-0.149011E 00	71	3	-0.555159E-01	71	4	0.395702E-01
71	7	-0.146809E 00	71	8	-0.624392E-01	71	9	0.272400E-01
71	12	-0.129671E 00	71	13	-0.586567E-01	71	14	0.235192E-01
71	17	-0.112016E 00	71	18	-0.517635E-01	71	19	0.260246E-01
71	23	-0.437999E-01	71	24	0.337459E-01	71	27	-0.107620E 00
71	28	-0.332524E-01	71	29	0.474577E-01	71	32	-0.936406E-01
71	33	-0.131448E-01	71	34	0.693766E-01	71	37	-0.585779E-01
71	38	0.233106E-01	71	39	0.102553E 00	71	42	0.417990E-02
71	43	0.793021E-01	71	44	0.147853E 00	71	47	0.102058E 00
71	48	0.161693E 00	71	49	0.210184E 00	71	52	0.233712E 00
71	53	0.271565E 00	71	54	0.286655E 00	71	57	0.410161E 00
71	58	0.407618E 00	71	59	0.372375E 00	71	63	0.558057E 00
71	64	0.457240E 00	71	67	0.883563E 00	71	68	0.695218E 00
71	69	0.527605E 00	71	72	0.103961E 01	71	73	0.778615E 00
71	74	0.570810E 00	71	77	0.103618E 01	71	78	0.790214E 00
71	79	0.576677E 00	71	82	0.921468E 00	71	83	0.728808E 00
71	84	0.548183E 00	71	87	0.734220E 00	71	88	0.609194E 00
71	89	0.484643E 00	71	92	0.509920E 00	71	93	0.461980E 00
71	94	0.401931E 00	71	97	0.291457E 00	71	98	0.315071E 00
71	99	0.312950E 00	71	103	0.186496E 00	71	104	0.228947E 00
71	107	0.222850E-02	71	108	0.851182E-01	71	109	0.157505E 00
71	112	-0.820552E-01	71	113	0.131412E-01	71	114	0.102030E 00
71	117	-0.130984E 00	71	118	-0.330048E-01	71	119	0.631888E-01
72	2	-0.782583E-01	72	3	0.405570E-02	72	4	0.882764E-01
72	7	-0.788634E-01	72	8	-0.284070E-02	72	9	0.777578E-01
72	12	-0.672641E-01	72	13	-0.356800E-03	72	14	0.748333E-01
72	17	-0.530798E-01	72	18	0.613310E-02	72	19	0.777652E-01
72	23	0.153234E-01	72	24	0.857471E-01	72	27	-0.381978E-01
72	28	0.278603E-01	72	29	0.991691E-01	72	32	-0.206143E-01
72	33	0.482563E-01	72	34	0.119432E 00	72	37	0.120511E-01
72	38	0.809104E-01	72	39	0.148596E 00	72	42	0.644722E-01
72	43	0.128088E 00	72	44	0.187267E 00	72	47	0.141646E 00
72	48	0.194671E 00	72	49	0.239039E 00	72	52	0.243090E 00
72	53	0.282581E 00	72	54	0.302069E 00	72	57	0.380617E 00
72	58	0.391945E 00	72	59	0.372869E 00	72	63	0.515002E 00
72	64	0.443601E 00	72	67	0.765832E 00	72	68	0.631725E 00
72	69	0.502346E 00	72	72	0.889278E 00	72	73	0.710564E 00
72	74	0.536054E 00	72	77	0.893579E 00	72	78	0.709300E 00
72	79	0.541736E 00	72	82	0.794403E 00	72	83	0.654037E 00
72	84	0.515909E 00	72	87	0.644721E 00	72	88	0.553152E 00
72	89	0.461190E 00	72	92	0.459384E 00	72	93	0.430858E 00
72	94	0.391166E 00	72	97	0.278916E 00	72	98	0.309184E 00

72 99	0.316543E 00	72 103	0.203407E 00	72 104	0.246425E 00
72 107	0.457453E-01	72 108	0.120481E 00	72 109	0.186917E 00
72 112	-0.219764E-01	72 113	0.615977E-01	72 114	0.140661E 00
72 117	-0.621677E-01	72 118	0.233184E-01	72 119	0.108107E 00
73 2	0.384290E-02	73 3	0.742204E-01	73 4	0.147007E 00
73 7	0.109200E-03	73 8	0.673540E-01	73 9	0.138490E 00
73 12	0.525850E-02	73 13	0.682510E-01	73 14	0.136384E 00
73 17	0.151532E-01	73 18	0.740651E-01	73 19	0.139683E 00
73 23	0.843681E-01	73 24	0.147831E 00	73 27	0.410431E-01
73 28	0.988584E-01	73 29	0.160813E 00	73 32	0.622390E-01
73 33	0.119319E 00	73 34	0.179149E 00	73 37	0.917908E-01
73 38	0.147507E 00	73 39	0.203829E 00	73 42	0.132146E 00
73 43	0.184558E 00	73 44	0.235056E 00	73 47	0.186047E 00
73 48	0.233568E 00	73 49	0.275379E 00	73 52	0.253848E 00
73 53	0.297183E 00	73 54	0.324051E 00	73 57	0.347781E 00
73 58	0.377428E 00	73 59	0.379299E 00	73 63	0.468810E 00
73 64	0.436921E 00	73 67	0.618587E 00	73 68	0.573467E 00
73 69	0.485959E 00	73 72	0.716813E 00	73 73	0.623254E 00
73 74	0.521134E 00	73 77	0.717435E 00	73 78	0.632043E 00
73 79	0.514501E 00	73 82	0.656658E 00	73 83	0.571854E 00
73 84	0.488737E 00	73 87	0.544443E 00	73 88	0.493774E 00
73 89	0.441063E 00	73 92	0.403691E 00	73 93	0.398631E 00
73 94	0.384198E 00	73 97	0.265610E 00	73 98	0.305114E 00
73 99	0.325042E 00	73 103	0.224871E 00	73 104	0.270187E 00
73 107	0.959008E-01	73 108	0.162776E 00	73 109	0.223941E 00
73 112	0.472378E-01	73 113	0.118810E 00	73 114	0.188017E 00
73 117	0.173111E-01	73 118	0.895987E-01	73 119	0.162556E 00
74 2	0.882365E-01	74 3	0.146834E 00	74 4	0.208539E 00
74 7	0.811087E-01	74 *	0.139714E 00	74 9	0.201735E 00
74 12	0.790614E-01	74 13	0.138432E 00	74 14	0.200016E 00
74 17	0.834659E-01	74 18	0.142697E 00	74 19	0.203130E 00
74 23	0.153048E 00	74 24	0.210824E 00	74 27	0.117160E 00
74 28	0.168354E 00	74 29	0.222763E 00	74 32	0.140410E 00
74 33	0.187854E 00	74 34	0.238679E 00	74 37	0.165672E 00
74 38	0.210833E 00	74 39	0.258596E 00	74 42	0.193542E 00
74 43	0.237530E 00	74 44	0.282515E 00	74 47	0.224486E 00
74 48	0.269018E 00	74 49	0.311609E 00	74 52	0.259989E 00
74 53	0.308760E 00	74 54	0.346319E 00	74 57	0.317296E 00
74 58	0.359625E 00	74 59	0.386549E 00	74 63	0.420602E 00
74 64	0.430877E 00	74 67	0.482157E 00	74 68	0.479844E 00
74 69	0.482801E 00	74 72	0.536416E 00	74 73	0.525858E 00
74 74	0.481672E 00	74 77	0.552198E 00	74 78	0.520349E 00
74 79	0.501342E 00	74 82	0.520236E 00	74 83	0.490884E 00
74 84	0.464199E 00	74 87	0.446964E 00	74 88	0.435188E 00
74 89	0.424547E 00	74 92	0.349329E 00	74 93	0.368263E 00
74 94	0.380845E 00	74 97	0.253344E 00	74 98	0.302956E 00
74 99	0.337088E 00	74 103	0.248397E 00	74 104	0.297365E 00
74 107	0.147453E 00	74 108	0.207329E 00	74 109	0.264279E 00
74 112	0.118357E 00	74 113	0.178505E 00	74 114	0.238596E 00
74 117	0.991061E-01	74 118	0.158497E 00	74 119	0.220107E 00
75 2	0.175907E 00	75 3	0.222166E 00	75 4	0.272414E 00
75 7	0.164980E 00	75 8	0.214416E 00	75 9	0.266975E 00
75 12	0.154699E 00	75 13	0.210160E 00	75 14	0.265087E 00
75 17	0.152025E 00	75 18	0.211730E 00	75 19	0.267284E 00
75 23	0.220731E 00	75 24	0.273681E 00	75 27	0.189408E 00
75 28	0.235323E 00	75 29	0.283709E 00	75 32	0.212568E 00
75 33	0.252378E 00	75 34	0.296404E 00	75 37	0.231705E 00

75	38	0.268861E 00	75	39	0.310897E 00	75	42	0.245840E 00
75	43	0.284166E 00	75	44	0.326902E 00	75	47	0.253878E 00
75	48	0.297685E 00	75	49	0.344329E 00	75	52	0.258851E 00
75	53	0.313372E 00	75	54	0.364220E 00	75	57	0.273399E 00
75	58	0.334833E 00	75	59	0.386769E 00	75	63	0.362345E 00
75	64	0.410463E 00	75	67	0.362026E 00	75	68	0.390129E 00
75	69	0.429769E 00	75	72	0.396378E 00	75	73	0.407321E 00
75	74	0.449952E 00	75	77	0.406273E 00	75	78	0.414242E 00
75	79	0.439463E 00	75	82	0.391660E 00	75	83	0.402661E 00
75	84	0.427288E 00	75	87	0.351460E 00	75	88	0.373839E 00
75	89	0.404007E 00	75	92	0.295001E 00	75	93	0.336527E 00
75	94	0.376955E 00	75	97	0.240843E 00	75	98	0.300581E 00
75	99	0.350046E 00	75	103	0.272623E 00	75	104	0.326182E 00
75	107	0.200229E 00	75	108	0.253391E 00	75	109	0.306674E 00
75	112	0.191710E 00	75	113	0.240369E 00	75	114	0.291474E 00
75	117	0.183872E 00	75	118	0.229977E 00	75	119	0.280033E 00
76	2	-0.135513E 00	76	3	-0.415755E-01	76	4	0.535489E-01
76	7	-0.141181E 00	76	8	-0.556147E-01	76	9	0.353448E-01
76	12	-0.131526E 00	76	13	-0.587862E-01	76	14	0.259670E-01
76	17	-0.122167E 00	76	18	-0.591443E-01	76	19	0.228801E-01
76	23	-0.588953E-01	76	24	0.250745E-01	76	27	-0.138904E 00
76	28	-0.563226E-01	76	29	0.334936E-01	76	32	-0.135189E 00
76	33	-0.436578E-01	76	34	0.506556E-01	76	37	-0.108804E 00
76	38	-0.133600E-01	76	39	0.800509E-01	76	42	-0.517434E-01
76	43	0.387444E-01	76	44	0.123188E 00	76	47	0.434798E-01
76	48	0.119499E 00	76	49	0.184991E 00	76	52	0.176358E 00
76	53	0.230482E 00	76	54	0.263226E 00	76	57	0.356206E 00
76	58	0.370169E 00	76	59	0.353807E 00	76	63	0.528569E 00
76	64	0.447757E 00	76	67	0.839143E 00	76	68	0.684647E 00
76	69	0.531537E 00	76	72	0.104078E 01	76	73	0.801652E 00
76	74	0.590641E 00	76	77	0.113734E 01	76	78	0.845480E 00
76	79	0.613370E 00	76	82	0.105771E 01	76	83	0.811014E 00
76	84	0.596139E 00	76	87	0.863333E 00	76	88	0.697883E 00
76	89	0.539163E 00	76	92	0.614438E 00	76	93	0.542159E 00
76	94	0.456420E 00	76	97	0.368336E 00	76	98	0.381428E 00
76	99	0.362503E 00	76	103	0.238823E 00	76	104	0.271170E 00
76	107	0.460252E-01	76	108	0.125429E 00	76	109	0.191835E 00
76	112	-0.499596E-01	76	113	0.434122E-01	76	114	0.128836E 00
76	117	-0.108834E 00	76	118	-0.114985E-01	76	119	0.831351E-01
77	2	-0.612429E-01	77	3	0.196764E-01	77	4	0.102272E 00
77	7	-0.698460E-01	77	8	0.577270E-02	77	9	0.860985E-01
77	12	-0.665025E-01	77	13	0.968800E-03	77	14	0.774500E-01
77	17	-0.615324E-01	77	18	-0.274300E-03	77	19	0.745708E-01
77	23	0.792700E-03	77	24	0.767798E-01	77	27	-0.684864E-01
77	28	0.517000E-02	77	29	0.847281E-01	77	32	-0.609298E-01
77	33	0.182099E-01	77	34	0.100162E 00	77	37	-0.362593E-01
77	38	0.450458E-01	77	39	0.125574E 00	77	42	0.113300E-01
77	43	0.886896E-01	77	44	0.162006E 00	77	47	0.871829E-01
77	48	0.154221E 00	77	49	0.213238E 00	77	52	0.191327E 00
77	53	0.243657E 00	77	54	0.277744E 00	77	57	0.333572E 00
77	58	0.356665E 00	77	59	0.352497E 00	77	63	0.485868E 00
77	64	0.430540E 00	77	67	0.722637E 00	77	68	0.615251E 00
77	69	0.500932E 00	77	72	0.893584E 00	77	73	0.715746E 00
77	74	0.551100E 00	77	77	0.966008E 00	77	78	0.762594E 00
77	79	0.568392E 00	77	82	0.907790E 00	77	83	0.723621E 00
77	84	0.555643E 00	77	87	0.742996E 00	77	88	0.626260E 00
77	89	0.507059E 00	77	92	0.543188E 00	77	93	0.496719E 00

77	94	0.437338E 00	77	97	0.342484E 00	77	98	0.365157E 00
77	99	0.359084E 00	77	103	0.249266E 00	77	104	0.283528E 00
77	107	0.869418E-01	77	108	0.157637E 00	77	109	0.218013E 00
77	112	0.107389E-01	77	113	0.911502E-01	77	114	0.165800E 00
77	117	-0.374200E-01	77	118	0.456997E-01	77	119	0.127487E 00
78	2	0.237368E-01	78	3	0.908929E-01	78	4	0.160405E 00
78	7	0.120698E-01	78	8	0.772665E-01	78	9	0.146527E 00
78	12	0.839540E-02	78	13	0.706884E-01	78	14	0.138705E 00
78	17	0.838200E-02	78	18	0.684412E-01	78	19	0.136047E 00
78	23	0.703654E-01	78	24	0.138241E 00	78	27	0.122104E-01
78	28	0.766537E-01	78	29	0.145616E 00	78	32	0.238186E-01
78	33	0.899543E-01	78	34	0.159068E 00	78	37	0.462134E-01
78	38	0.112722E 00	78	39	0.179991E 00	78	42	0.828568E-01
78	43	0.146749E 00	78	44	0.208969E 00	78	47	0.136735E 00
78	48	0.195150E 00	78	49	0.248506E 00	78	52	0.208584E 00
78	53	0.260516E 00	78	54	0.297950E 00	78	57	0.308773E 00
78	58	0.343790E 00	78	59	0.355581E 00	78	63	0.440870E 00
78	64	0.416858E 00	78	67	0.595893E 00	78	68	0.538613E 00
78	69	0.474980E 00	78	72	0.711043E 00	78	73	0.632096E 00
78	74	0.518187E 00	78	77	0.768925E 00	78	78	0.657870E 00
78	79	0.541534E 00	78	82	0.722226E 00	78	83	0.638341E 00
78	84	0.521664E 00	78	87	0.612404E 00	78	88	0.547125E 00
78	89	0.479485E 00	78	92	0.463200E 00	78	93	0.448884E 00
78	94	0.421612E 00	78	97	0.314352E 00	78	98	0.349292E 00
78	99	0.359902E 00	78	103	0.263206E 00	78	104	0.301419E 00
78	107	0.133531E 00	78	108	0.195893E 00	78	109	0.251071E 00
78	112	0.797895E-01	78	113	0.146887E 00	78	114	0.210791E 00
78	117	0.440155E-01	78	118	0.112196E 00	78	119	0.180710E 00
79	2	0.108281E 00	79	3	0.163005E 00	79	4	0.220950E 00
79	7	0.940832E-01	79	8	0.149929E 00	79	9	0.209395E 00
79	12	0.837451E-01	79	13	0.141764E 00	79	14	0.202424E 00
79	17	0.788184E-01	79	18	0.138541E 00	79	19	0.199977E 00
79	23	0.141187E 00	79	24	0.202097E 00	79	27	0.927401E-01
79	28	0.149105E 00	79	29	0.208808E 00	79	32	0.107782E 00
79	33	0.162320E 00	79	34	0.220196E 00	79	37	0.127276E 00
79	38	0.180706E 00	79	39	0.236621E 00	79	42	0.152607E 00
79	43	0.204984E 00	79	44	0.258295E 00	79	47	0.184502E 00
79	48	0.236311E 00	79	49	0.286406E 00	79	52	0.224670E 00
79	53	0.277922E 00	79	54	0.321224E 00	79	57	0.283949E 00
79	58	0.332008E 00	79	59	0.362236E 00	79	63	0.396774E 00
79	64	0.407254E 00	79	67	0.471559E 00	79	68	0.464041E 00
79	69	0.452739E 00	79	72	0.542838E 00	79	73	0.516706E 00
79	74	0.501353E 00	79	77	0.568759E 00	79	78	0.546237E 00
79	79	0.492664E 00	79	82	0.551307E 00	79	83	0.521439E 00
79	84	0.503886E 00	79	87	0.484128E 00	79	88	0.470258E 00
79	89	0.455779E 00	79	92	0.385952E 00	79	93	0.402148E 00
79	94	0.410182E 00	79	97	0.286635E 00	79	98	0.334877E 00
79	99	0.364535E 00	79	103	0.278075E 00	79	104	0.322654E 00
79	107	0.178774E 00	79	108	0.234761E 00	79	109	0.287048E 00
79	112	0.147523E 00	79	113	0.203173E 00	79	114	0.258423E 00
79	117	0.124540E 00	79	118	0.179403E 00	79	119	0.236452E 00
80	2	0.192073E 00	80	3	0.235250E 00	80	4	0.282692E 00
80	7	0.176027E 00	80	8	0.223120E 00	80	9	0.273567E 00
80	12	0.159429E 00	80	13	0.213601E 00	80	14	0.267509E 00
80	17	0.149638E 00	80	18	0.209424E 00	80	19	0.265257E 00
80	23	0.212602E 00	80	24	0.267207E 00	80	27	0.172776E 00
80	28	0.221769E 00	80	29	0.273096E 00	80	32	0.190429E 00

80	33	0.234390E 00	80	34	0.282234E 00	80	37	0.206112E 00
80	38	0.247849E 00	80	39	0.293995E 00	80	42	0.219204E 00
80	43	0.261767E 00	80	44	0.308149E 00	80	47	0.228878E 00
80	48	0.275761E 00	80	49	0.324788E 00	80	52	0.237983E 00
80	53	0.293562E 00	80	54	0.344821E 00	80	57	0.258131E 00
80	58	0.318421E 00	80	59	0.368474E 00	80	63	0.350694E 00
80	64	0.394550E 00	80	67	0.357387E 00	80	68	0.384265E 00
80	69	0.419867E 00	80	72	0.396824E 00	80	73	0.409611E 00
80	74	0.438033E 00	80	77	0.413582E 00	80	78	0.417210E 00
80	79	0.454440E 00	80	82	0.402988E 00	80	83	0.412956E 00
80	84	0.439687E 00	80	87	0.366310E 00	80	88	0.388405E 00
80	89	0.421595E 00	80	92	0.311716E 00	80	93	0.353769E 00
80	94	0.395889E 00	80	97	0.258568E 00	80	98	0.319085E 00
80	99	0.369066E 00	80	103	0.291715E 00	80	104	0.344580E 00
80	107	0.221335E 00	80	108	0.272494E 00	80	109	0.323909E 00
80	112	0.212872E 00	80	113	0.258595E 00	80	114	0.306985E 00
80	117	0.203364E 00	80	118	0.246153E 00	80	119	0.293179E 00
81	2	-0.932715E-01	81	3	-0.941890E-02	81	4	0.749686E-01
81	7	-0.109354E 00	81	8	-0.311298E-01	81	9	0.517473E-01
81	12	-0.110796E 00	81	13	-0.425200E-01	81	14	0.368710E-01
81	17	-0.112066E 00	81	18	-0.508742E-01	81	19	0.280908E-01
81	23	-0.581646E-01	81	24	0.245805E-01	81	27	-0.145783E 00
81	28	-0.627563E-01	81	29	0.273116E-01	81	32	-0.150078E 00
81	33	-0.572214E-01	81	34	0.386942E-01	81	37	-0.132256E 00
81	38	-0.344763E-01	81	39	0.620751E-01	81	42	-0.846356E-01
81	43	0.957600E-02	81	44	0.990010E-01	81	47	-0.387400E-03
81	48	0.811428E-01	81	49	0.154036E 00	81	52	0.120308E 00
81	53	0.181703E 00	81	54	0.225383E 00	81	57	0.284515E 00
81	58	0.309550E 00	81	59	0.309817E 00	81	63	0.456667E 00
81	64	0.400006E 00	81	67	0.724438E 00	81	68	0.606206E 00
81	69	0.484796E 00	81	72	0.920025E 00	81	73	0.730940E 00
81	74	0.551130E 00	81	77	0.105250E 01	81	78	0.803039E 00
81	79	0.586194E 00	81	82	0.107266E 01	81	83	0.799636E 00
81	84	0.584928E 00	81	87	0.920932E 00	81	88	0.719361E 00
81	89	0.543192E 00	81	92	0.677430E 00	81	93	0.580111E 00
81	94	0.473061E 00	81	97	0.427998E 00	81	98	0.425281E 00
81	99	0.387111E 00	81	103	0.284368E 00	81	104	0.299580E 00
81	107	0.106341E 00	81	108	0.170763E 00	81	109	0.221113E 00
81	112	0.726290E-02	81	113	0.864217E-01	81	114	0.156899E 00
81	117	-0.579078E-01	81	118	0.268961E-01	81	119	0.108347E 00
82	2	-0.204174E-01	82	3	0.508913E-01	82	4	0.123458E 00
82	7	-0.390803E-01	82	8	0.295036E-01	82	9	0.102283E 00
82	12	-0.469420E-01	82	13	0.163663E-01	82	14	0.880132E-01
82	17	-0.531046E-01	82	18	0.676800E-02	82	19	0.792261E-01
82	23	-0.156300E-03	82	24	0.755141E-01	82	27	-0.785506E-01
82	28	-0.328250E-02	82	29	0.776787E-01	82	32	-0.791999E-01
82	33	0.267090E-02	82	34	0.874864E-01	82	37	-0.624296E-01
82	38	0.226021E-01	82	39	0.107398E 00	82	42	-0.225200E-01
82	43	0.595632E-01	82	44	0.138531E 00	82	47	0.453412E-01
82	48	0.118093E 00	82	49	0.184349E 00	82	52	0.141428E 00
82	53	0.200028E 00	82	54	0.243600E 00	82	57	0.273392E 00
82	58	0.304639E 00	82	59	0.313817E 00	82	63	0.425850E 00
82	64	0.389162E 00	82	67	0.634792E 00	82	68	0.549657E 00
82	69	0.460649E 00	82	72	0.791606E 00	82	73	0.654587E 00
82	74	0.517502E 00	82	77	0.905541E 00	82	78	0.718560E 00
82	79	0.548540E 00	82	82	0.914867E 00	82	83	0.726832E 00
82	84	0.546660E 00	82	87	0.797007E 00	82	88	0.650260E 00

82	89	0.514119E 00	82	92	0.592037E 00	82	93	0.532163E 00
82	94	0.455307E 00	82	97	0.393520E 00	82	98	0.404731E 00
82	99	0.383616E 00	82	103	0.291061E 00	82	104	0.311213E 00
82	107	0.142126E 00	82	108	0.199998E 00	82	109	0.246523E 00
82	112	0.643944E-01	82	113	0.132020E 00	82	114	0.193292E 00
82	117	0.112466E-01	82	118	0.826873E-01	82	119	0.152366E 00
83	2	0.617763E-01	83	3	0.120315E 00	83	4	0.181043E 00
83	7	0.407719E-01	83	8	0.996339E-01	83	9	0.162293E 00
83	12	0.262389E-01	83	13	0.849160E-01	83	14	0.148889E 00
83	17	0.150778E-01	83	18	0.742919E-01	83	19	0.140298E 00
83	23	0.681109E-01	83	24	0.136551E 00	83	27	-0.187200E-03
83	28	0.668701E-01	83	29	0.138228E 00	83	32	0.338740E-02
83	33	0.733930E-01	83	34	0.146361E 00	83	37	0.188301E-01
83	38	0.901087E-01	83	39	0.162414E 00	83	42	0.495909E-01
83	43	0.118817E 00	83	44	0.186946E 00	83	47	0.985150E-01
83	48	0.162433E 00	83	49	0.222397E 00	83	52	0.166431E 00
83	53	0.223209E 00	83	54	0.268120E 00	83	57	0.261758E 00
83	58	0.301592E 00	83	59	0.322580E 00	83	63	0.393685E 00
83	64	0.381752E 00	83	67	0.533798E 00	83	68	0.489114E 00
83	69	0.439232E 00	83	72	0.651276E 00	83	73	0.569775E 00
83	74	0.488135E 00	83	77	0.722581E 00	83	78	0.636140E 00
83	79	0.517654E 00	83	82	0.733153E 00	83	83	0.633453E 00
83	84	0.527342E 00	83	87	0.640583E 00	83	88	0.585456E 00
83	89	0.492889E 00	83	92	0.500397E 00	83	93	0.479377E 00
83	94	0.443657E 00	83	97	0.354394E 00	83	98	0.384390E 00
83	99	0.385091E 00	83	103	0.300400E 00	83	104	0.328520E 00
83	107	0.181858E 00	83	108	0.234282E 00	83	109	0.278585E 00
83	112	0.128060E 00	83	113	0.184484E 00	83	114	0.237297E 00
83	117	0.886565E-01	83	118	0.146643E 00	83	119	0.204766E 00
84	2	0.140575E 00	84	3	0.188406E 00	84	4	0.239538E 00
84	7	0.118416E 00	84	8	0.169163E 00	84	9	0.223496E 00
84	12	0.984733E-01	84	13	0.153674E 00	84	14	0.211333E 00
84	17	0.834027E-01	84	18	0.142751E 00	84	19	0.203330E 00
84	23	0.137869E 00	84	24	0.199889E 00	84	27	0.794625E-01
84	28	0.138842E 00	84	29	0.201338E 00	84	32	0.872926E-01
84	33	0.146040E 00	84	34	0.207968E 00	84	37	0.101145E 00
84	38	0.159477E 00	84	39	0.220277E 00	84	42	0.122609E 00
84	43	0.180017E 00	84	44	0.238517E 00	84	47	0.152330E 00
84	48	0.208665E 00	84	49	0.263798E 00	84	52	0.192079E 00
84	53	0.248361E 00	84	54	0.296278E 00	84	57	0.251205E 00
84	58	0.300746E 00	84	59	0.335357E 00	84	63	0.364123E 00
84	64	0.378708E 00	84	67	0.437135E 00	84	68	0.430604E 00
84	69	0.422466E 00	84	72	0.514346E 00	84	73	0.487871E 00
84	74	0.462700E 00	84	77	0.554866E 00	84	78	0.522284E 00
84	79	0.502648E 00	84	82	0.547042E 00	84	83	0.532068E 00
84	84	0.485113E 00	84	87	0.496698E 00	84	88	0.487344E 00
84	89	0.486589E 00	84	92	0.408418E 00	84	93	0.426824E 00
84	94	0.434335E 00	84	97	0.315120E 00	84	98	0.362787E 00
84	99	0.389130E 00	84	103	0.308674E 00	84	104	0.347808E 00
84	107	0.217568E 00	84	108	0.266938E 00	84	109	0.312149E 00
84	112	0.187367E 00	84	113	0.235158E 00	84	114	0.282463E 00
84	117	0.162085E 00	84	118	0.209025E 00	84	119	0.258236E 00
85	2	0.214081E 00	85	3	0.253168E 00	85	4	0.296868E 00
85	7	0.192696E 00	85	8	0.236679E 00	85	9	0.284217E 00
85	12	0.169277E 00	85	13	0.221765E 00	85	14	0.274037E 00
85	17	0.152001E 00	85	18	0.211753E 00	85	19	0.267340E 00
85	23	0.209144E 00	85	24	0.264828E 00	85	27	0.161573E 00

85	28	0.212990E 00	85	29	0.266520E 00	85	32	0.173965E 00
85	33	0.221162E 00	85	34	0.271943E 00	85	37	0.185999E 00
85	38	0.231273E 00	85	39	0.280636E 00	85	42	0.197353E 00
85	43	0.243168E 00	85	44	0.292471E 00	85	47	0.207021E 00
85	48	0.256297E 00	85	49	0.307420E 00	85	52	0.217858E 00
85	53	0.274268E 00	85	54	0.326364E 00	85	57	0.240467E 00
85	58	0.299984E 00	85	59	0.349496E 00	85	63	0.333798E 00
85	64	0.375765E 00	85	67	0.343530E 00	85	68	0.370236E 00
85	69	0.402513E 00	85	72	0.386504E 00	85	73	0.399904E 00
85	74	0.425913E 00	85	77	0.407306E 00	85	78	0.414926E 00
85	79	0.439848E 00	85	82	0.403420E 00	85	83	0.411172E 00
85	84	0.451832E 00	85	87	0.371732E 00	85	88	0.394688E 00
85	89	0.431659E 00	85	92	0.322269E 00	85	93	0.365643E 00
85	94	0.411871E 00	85	97	0.273825E 00	85	98	0.335465E 00
85	99	0.387326E 00	85	103	0.311256E 00	85	104	0.363851E 00
85	107	0.245568E 00	85	108	0.294019E 00	85	109	0.343263E 00
85	112	0.238856E 00	85	113	0.280611E 00	85	114	0.325534E 00
85	117	0.228599E 00	85	118	0.266944E 00	85	119	0.309980E 00
86	2	-0.181698E-01	86	3	0.436807E-01	86	4	0.105422E 00
86	7	-0.481101E-01	86	8	0.132133E-01	86	9	0.778227E-01
86	12	-0.658900E-01	86	13	-0.871160E-02	86	14	0.570759E-01
86	17	-0.821767E-01	86	18	-0.271627E-01	86	19	0.417932E-01
86	23	-0.432234E-01	86	24	0.316806E-01	86	27	-0.132779E 00
86	28	-0.553552E-01	86	29	0.277778E-01	86	32	-0.144033E 00
86	33	-0.572963E-01	86	34	0.321458E-01	86	37	-0.134845E 00
86	38	-0.433985E-01	86	39	0.475532E-01	86	42	-0.990897E-01
86	43	-0.103406E-01	86	44	0.752501E-01	86	47	-0.317339E-01
86	48	0.464922E-01	86	49	0.118767E 00	86	52	0.669814E-01
86	53	0.128072E 00	86	54	0.176646E 00	86	57	0.201268E 00
86	58	0.232484E 00	86	59	0.246476E 00	86	63	0.353808E 00
86	64	0.322799E 00	86	67	0.558399E 00	86	68	0.479697E 00
86	69	0.397404E 00	86	72	0.723903E 00	86	73	0.590904E 00
86	74	0.460623E 00	86	77	0.848723E 00	86	78	0.669274E 00
86	79	0.502002E 00	86	82	0.910141E 00	86	83	0.697301E 00
86	84	0.514680E 00	86	87	0.871386E 00	86	88	0.657718E 00
86	89	0.495103E 00	86	92	0.687388E 00	86	93	0.564122E 00
86	94	0.447851E 00	86	97	0.465850E 00	86	98	0.441211E 00
86	99	0.383300E 00	86	103	0.321108E 00	86	104	0.312437E 00
86	107	0.184660E 00	86	108	0.221485E 00	86	109	0.245147E 00
86	112	0.930599E-01	86	113	0.144143E 00	86	114	0.187167E 00
86	117	0.262003E-01	86	118	0.850276E-01	86	119	0.140445E 00
87	2	0.473153E-01	87	3	0.998732E-01	87	4	0.153266E 00
87	7	0.158788E-01	87	8	0.701286E-01	87	9	0.127569E 00
87	12	-0.733820E-02	87	13	0.468295E-01	87	14	0.107380E 00
87	17	-0.280841E-01	87	18	0.272435E-01	87	19	0.920606E-01
87	23	0.114121E-01	87	24	0.817462E-01	87	27	-0.717058E-01
87	28	0.556200E-03	87	29	0.774133E-01	87	32	-0.796342E-01
87	33	-0.791100E-03	87	34	0.806504E-01	87	37	-0.707904E-01
87	38	0.112403E-01	87	39	0.935400E-01	87	42	-0.405373E-01
87	43	0.391690E-01	87	44	0.116980E 00	87	47	0.145049E-01
87	48	0.862729E-01	87	49	0.153648E 00	87	52	0.945746E-01
87	53	0.153925E 00	87	54	0.202498E 00	87	57	0.204787E 00
87	58	0.241061E 00	87	59	0.261614E 00	87	63	0.343053E 00
87	64	0.326518E 00	87	67	0.504797E 00	87	68	0.449313E 00
87	69	0.390366E 00	87	72	0.642827E 00	87	73	0.543180E 00
87	74	0.445200E 00	87	77	0.741476E 00	87	78	0.610664E 00
87	79	0.482281E 00	87	82	0.796862E 00	87	83	0.638727E 00

87	84	0.495471E 00	87	87	0.757089E 00	87	88	0.617065E 00
87	89	0.478705E 00	87	92	0.612188E 00	87	93	0.529746E 00
87	94	0.441886E 00	87	97	0.426154E 00	87	98	0.425696E 00
87	99	0.387894E 00	87	103	0.327721E 00	87	104	0.328656E 00
87	107	0.212299E 00	87	108	0.248080E 00	87	109	0.272634E 00
87	112	0.141386E 00	87	113	0.185763E 00	87	114	0.224087E 00
87	117	0.869411E-01	87	118	0.136428E 00	87	119	0.184133E 00
88	2	0.120233E 00	88	3	0.163977E 00	88	4	0.209720E 00
88	7	0.877747E-01	88	8	0.135435E 00	88	9	0.186278E 00
88	12	0.592436E-01	88	13	0.111122E 00	88	14	0.166957E 00
88	17	0.343248E-01	88	18	0.908406E-01	88	19	0.151896E 00
88	23	0.758271E-01	88	24	0.141659E 00	88	27	0.856000E-04
88	28	0.668564E-01	88	29	0.137098E 00	88	32	-0.372420E-02
88	33	0.664396E-01	88	34	0.139233E 00	88	37	0.474240E-02
88	38	0.764087E-01	88	39	0.149358E 00	88	42	0.285107E-01
88	43	0.984301E-01	88	44	0.168020E 00	88	47	0.691079E-01
88	48	0.134262E 00	88	49	0.196905E 00	88	52	0.127482E 00
88	53	0.185865E 00	88	54	0.235521E 00	88	57	0.209946E 00
88	58	0.253234E 00	88	59	0.282593E 00	88	63	0.333321E 00
88	64	0.334826E 00	88	67	0.445210E 00	88	68	0.417450E 00
88	69	0.387057E 00	88	72	0.551266E 00	88	73	0.492414E 00
88	74	0.433361E 00	88	77	0.624905E 00	88	78	0.545640E 00
88	79	0.468270E 00	88	82	0.651790E 00	88	83	0.585284E 00
88	84	0.484999E 00	88	87	0.625301E 00	88	88	0.559123E 00
88	89	0.483434E 00	88	92	0.509624E 00	88	93	0.503239E 00
88	94	0.446055E 00	88	97	0.384659E 00	88	98	0.408663E 00
88	99	0.400758E 00	88	103	0.337059E 00	88	104	0.351734E 00
88	107	0.242414E 00	88	108	0.279056E 00	88	109	0.307218E 00
88	112	0.194451E 00	88	113	0.233318E 00	88	114	0.268599E 00
88	117	0.154022E 00	88	118	0.194891E 00	88	119	0.235937E 00
89	2	0.186479E 00	89	3	0.224035E 00	89	4	0.264988E 00
89	7	0.155141E 00	89	8	0.198169E 00	89	9	0.244563E 00
89	12	0.123714E 00	89	13	0.174515E 00	89	14	0.227026E 00
89	17	0.969723E-01	89	18	0.155184E 00	89	19	0.213183E 00
89	23	0.142436E 00	89	24	0.203905E 00	89	27	0.756385E-01
89	28	0.136458E 00	89	29	0.199824E 00	89	32	0.768014E-01
89	33	0.137633E 00	89	34	0.01334E 00	89	37	0.850350E-01
89	38	0.145730E 00	89	39	0.108919E 00	89	42	0.101658E 00
89	43	0.161481E 00	89	44	0.222723E 00	89	47	0.126851E 00
89	48	0.185470E 00	89	49	0.243643E 00	89	52	0.162320E 00
89	53	0.220259E 00	89	54	0.271744E 00	89	57	0.215840E 00
89	58	0.267049E 00	89	59	0.306462E 00	89	63	0.324459E 00
89	64	0.345724E 00	89	67	0.385052E 00	89	68	0.385761E 00
89	69	0.385987E 00	89	72	0.459775E 00	89	73	0.440192E 00
89	74	0.423380E 00	89	77	0.506331E 00	89	78	0.479097E 00
89	79	0.454842E 00	89	82	0.515182E 00	89	83	0.495039E 00
89	84	0.486548E 00	89	87	0.479146E 00	89	88	0.488268E 00
89	89	0.461428E 00	89	92	0.413309E 00	89	93	0.438451E 00
89	94	0.461207E 00	89	97	0.337079E 00	89	98	0.386805E 00
89	99	0.412022E 00	89	103	0.340408E 00	89	104	0.373583E 00
89	107	0.264426E 00	89	108	0.304549E 00	89	109	0.340289E 00
89	112	0.239114E 00	89	113	0.275470E 00	89	114	0.311515E 00
89	117	0.213287E 00	89	118	0.248540E 00	89	119	0.286308E 00
90	2	0.241699E 00	90	3	0.275753E 00	90	4	0.314879E 00
90	7	0.214888E 00	90	8	0.255030E 00	90	9	0.298921E 00
90	12	0.184238E 00	90	13	0.234664E 00	90	14	0.284719E 00
90	17	0.159172E 00	90	18	0.218788E 00	90	19	0.273621E 00

90	23	0.210477E 00	90	24	0.266664E 00	90	27	0.155978E 00
90	28	0.209158E 00	90	29	0.264137E 00	90	32	0.163426E 00
90	33	0.212930E 00	90	34	0.265730E 00	90	37	0.171714E 00
90	38	0.219451E 00	90	39	0.271071E 00	90	42	0.180700E 00
90	43	0.228746E 00	90	44	0.280142E 00	90	47	0.188951E 00
90	48	0.239875E 00	90	49	0.292623E 00	90	52	0.199397E 00
90	53	0.256358E 00	90	54	0.309429E 00	90	57	0.221661E 00
90	58	0.280786E 00	90	59	0.330733E 00	90	63	0.313581E 00
90	64	0.355600E 00	90	67	0.321958E 00	90	68	0.349851E 00
90	69	0.381737E 00	90	72	0.365883E 00	90	73	0.381378E 00
90	74	0.406041E 00	90	77	0.390088E 00	90	78	0.400575E 00
90	79	0.425083E 00	90	82	0.391155E 00	90	83	0.404761E 00
90	84	0.434794E 00	90	87	0.368034E 00	90	88	0.390105E 00
90	89	0.442189E 00	90	92	0.325804E 00	90	93	0.370828E 00
90	94	0.421249E 00	90	97	0.285489E 00	90	98	0.348130E 00
90	99	0.413628E 00	90	103	0.330152E 00	90	104	0.383299E 00
90	107	0.271916E 00	90	108	0.317129E 00	90	109	0.364267E 00
90	112	0.268837E 00	90	113	0.305771E 00	90	114	0.346762E 00
90	117	0.258936E 00	90	118	0.291855E 00	90	119	0.330149E 00
91	2	0.903768E-01	91	3	0.118357E 00	91	4	0.145909E 00
91	7	0.428988E-01	91	8	0.778885E-01	91	9	0.114475E 00
91	12	0.273880E-02	91	13	0.425423E-01	91	14	0.871636E-01
91	17	-0.342994E-01	91	18	0.109701E-01	91	19	0.640901E-01
91	23	-0.161923E-01	91	24	0.459630E-01	91	27	-0.105298E 00
91	28	-0.372660E-01	91	29	0.340957E-01	91	32	-0.123701E 00
91	33	-0.476165E-01	91	34	0.301432E-01	91	37	-0.123457E 00
91	38	-0.436881E-01	91	39	0.360482E-01	91	42	-0.100797E 00
91	43	-0.233603E-01	91	44	0.525940E-01	91	47	-0.535556E-01
91	48	0.154982E-01	91	49	0.816226E-01	91	52	0.176256E-01
91	53	0.730709E-01	91	54	0.121965E 00	91	57	0.113628E 00
91	58	0.147090E 00	91	59	0.171860E 00	91	63	0.233644E 00
91	64	0.227729E 00	91	67	0.363345E 00	91	68	0.325071E 00
91	69	0.284424E 00	91	72	0.484504E 00	91	73	0.409960E 00
91	74	0.336029E 00	91	77	0.583690E 00	91	78	0.477929E 00
91	79	0.376048E 00	91	82	0.648726E 00	91	83	0.519372E 00
91	84	0.398959E 00	91	87	0.669019E 00	91	88	0.523747E 00
91	89	0.401171E 00	91	92	0.616606E 00	91	93	0.485049E 00
91	94	0.384329E 00	91	97	0.477849E 00	91	98	0.421834E 00
91	99	0.351203E 00	91	103	0.346661E 00	91	104	0.309059E 00
91	107	0.279815E 00	91	108	0.276609E 00	91	109	0.263887E 00
91	112	0.207196E 00	91	113	0.216500E 00	91	114	0.220158E 00
91	117	0.143939E 00	91	118	0.163387E 00	91	119	0.180314E 00
92	2	0.142751E 00	92	3	0.167408E 00	92	4	0.192679E 00
92	7	0.954896E-01	92	8	0.128177E 00	92	9	0.162772E 00
92	12	0.520010E-01	92	13	0.923254E-01	92	14	0.136035E 00
92	17	0.120471E-01	92	18	0.602964E-01	92	19	0.113111E 00
92	23	0.336967E-01	92	24	0.950500E-01	92	27	-0.524477E-01
92	28	0.140158E-01	92	29	0.831568E-01	92	32	-0.677518E-01
92	33	0.464890E-02	92	34	0.787883E-01	92	37	-0.670677E-01
92	38	0.789560E-02	92	39	0.834444E-01	92	42	-0.475296E-01
92	43	0.253574E-01	92	44	0.976257E-01	92	47	-0.795270E-02
92	48	0.584366E-01	92	49	0.122802E 00	92	52	0.515598E-01
92	53	0.107802E 00	92	54	0.158056E 00	92	57	0.133268E 00
92	58	0.171971E 00	92	59	0.201935E 00	92	63	0.247795E 00
92	64	0.251346E 00	92	67	0.352855E 00	92	68	0.328202E 00
92	69	0.301758E 00	92	72	0.457927E 00	92	73	0.402682E 00
92	74	0.347975E 00	92	77	0.541826E 00	92	78	0.461798E 00

92	79	0.384574E 00	92	82	0.591228E 00	92	83	0.499300E 00
92	84	0.407075E 00	92	87	0.611443E 00	92	88	0.507361E 00
92	89	0.411613E 00	92	92	0.559686E 00	92	93	0.486098E 00
92	94	0.397071E 00	92	97	0.450394E 00	92	98	0.424166E 00
92	99	0.371633E 00	92	103	0.358997E 00	92	104	0.335799E 00
92	107	0.297470E 00	92	108	0.301882E 00	92	109	0.296875E 00
92	112	0.242158E 00	92	113	0.252944E 00	92	114	0.259036E 00
92	117	0.190518E 00	92	118	0.207765E 00	92	119	0.223830E 00
93	2	0.201672E 00	93	3	0.224496E 00	93	4	0.249210E 00
93	7	0.154977E 00	93	8	0.186744E 00	93	9	0.220862E 00
93	12	0.108312E 00	93	13	0.150626E 00	93	14	0.194798E 00
93	17	0.657734E-01	93	18	0.118507E 00	93	19	0.177190E 00
93	23	0.930079E-01	93	24	0.154402E 00	93	27	0.100133E-01
93	28	0.753010E-01	93	29	0.142670E 00	93	32	-0.139260E-02
93	33	0.673029E-01	93	34	0.137969E 00	93	37	-0.130000E-03
93	38	0.698493E-01	93	39	0.141276E 00	93	42	0.159912E-01
93	43	0.842535E-01	93	44	0.153025E 00	93	47	0.464138E-01
93	48	0.110540E 00	93	49	0.173791E 00	93	52	0.921156E-01
93	53	0.150320E 00	93	54	0.203246E 00	93	57	0.157121E 00
93	58	0.203111E 00	93	59	0.240348E 00	93	63	0.266749E 00
93	64	0.282637E 00	93	67	0.342415E 00	93	68	0.334901E 00
93	69	0.326343E 00	93	72	0.429919E 00	93	73	0.397979E 00
93	74	0.367226E 00	93	77	0.496065E 00	93	78	0.448112E 00
93	79	0.401084E 00	93	82	0.531940E 00	93	83	0.478845E 00
93	84	0.425532E 00	93	87	0.530931E 00	93	88	0.502851E 00
93	89	0.435825E 00	93	92	0.492474E 00	93	93	0.476920E 00
93	94	0.436053E 00	93	97	0.405135E 00	93	98	0.440404E 00
93	99	0.407179E 00	93	103	0.375598E 00	93	104	0.375086E 00
93	107	0.318030E 00	93	108	0.333871E 00	93	109	0.340409E 00
93	112	0.281993E 00	93	113	0.296587E 00	93	114	0.307973E 00
93	117	0.243124E 00	93	118	0.259958E 00	93	119	0.277248E 00
94	2	0.245943E 00	94	3	0.270055E 00	94	4	0.297715E 00
94	7	0.204144E 00	94	8	0.236993E 00	94	9	0.272873E 00
94	12	0.159113E 00	94	13	0.204110E 00	94	14	0.249606E 00
94	17	0.118744E 00	94	18	0.175333E 00	94	19	0.229436E 00
94	23	0.153995E 00	94	24	0.213840E 00	94	27	0.792555E-01
94	28	0.140595E 00	94	29	0.203798E 00	94	32	0.738562E-01
94	33	0.135611E 00	94	34	0.199769E 00	94	37	0.763910E-01
94	38	0.137997E 00	94	39	0.202117E 00	94	42	0.877289E-01
94	43	0.148396E 00	94	44	0.210896E 00	94	47	0.106960E 00
94	48	0.166469E 00	94	49	0.226442E 00	94	52	0.135763E 00
94	53	0.194471E 00	94	54	0.248827E 00	94	57	0.180782E 00
94	58	0.233182E 00	94	59	0.277559E 00	94	63	0.281668E 00
94	64	0.310966E 00	94	67	0.323397E 00	94	68	0.334532E 00
94	69	0.346185E 00	94	72	0.389909E 00	94	73	0.383393E 00
94	74	0.379962E 00	94	77	0.436484E 00	94	78	0.421047E 00
94	79	0.409485E 00	94	82	0.455985E 00	94	83	0.444437E 00
94	84	0.434278E 00	94	87	0.443050E 00	94	88	0.448348E 00
94	89	0.461193E 00	94	92	0.398045E 00	94	93	0.441213E 00
94	94	0.437006E 00	94	97	0.351022E 00	94	98	0.404597E 00
94	99	0.442384E 00	94	103	0.374068E 00	94	104	0.401893E 00
94	107	0.318477E 00	94	108	0.347732E 00	94	109	0.372525E 00
94	112	0.302179E 00	94	113	0.324193E 00	94	114	0.346205E 00
94	117	0.277800E 00	94	118	0.298001E 00	94	119	0.321107E 00
95	2	0.273554E 00	95	3	0.301953E 00	95	4	0.336060E 00
95	7	0.241527E 00	95	8	0.277322E 00	95	9	0.317107E 00
95	12	0.203528E 00	95	13	0.251642E 00	95	14	0.299082E 00

95	17	0.170610E 00	95	18	0.230035E 00	95	19	0.283722E 00
95	23	0.216231E 00	95	24	0.272429E 00	95	27	0.155655E 00
95	28	0.209996E 00	95	29	0.265746E 00	95	32	0.158548E 00
95	33	0.209504E 00	95	34	0.263479E 00	95	37	0.163099E 00
95	38	0.212313E 00	95	39	0.265287E 00	95	42	0.169054E 00
95	43	0.218421E 00	95	44	0.271128E 00	95	47	0.174799E 00
95	48	0.226685E 00	95	49	0.280549E 00	95	52	0.183191E 00
95	53	0.240415E 00	95	54	0.294416E 00	95	57	0.202932E 00
95	58	0.261943E 00	95	59	0.312905E 00	95	63	0.291820E 00
95	64	0.335232E 00	95	67	0.295308E 00	95	68	0.325785E 00
95	69	0.359436E 00	95	72	0.337750E 00	95	73	0.356743E 00
95	74	0.382942E 00	95	77	0.363755E 00	95	78	0.378301E 00
95	79	0.403131E 00	95	82	0.369769E 00	95	83	0.387589E 00
95	84	0.418385E 00	95	87	0.354033E 00	95	88	0.382565E 00
95	89	0.424550E 00	95	92	0.322978E 00	95	93	0.366992E 00
95	94	0.432204E 00	95	97	0.292711E 00	95	98	0.355794E 00
95	99	0.414373E 00	95	103	0.346631E 00	95	104	0.401652E 00
95	107	0.298657E 00	95	108	0.340384E 00	95	109	0.386045E 00
95	112	0.301151E 00	95	113	0.332798E 00	95	114	0.369951E 00
95	117	0.292895E 00	95	118	0.319782E 00	95	119	0.353048E 00
96	2	0.223293E 00	96	3	0.206631E 00	96	4	0.190000E 00
96	7	0.156726E 00	96	8	0.156610E 00	96	9	0.156453E 00
96	12	0.900590E-01	96	13	0.106412E 00	96	14	0.122904E 00
96	17	0.278870E-01	96	18	0.597484E-01	96	19	0.915823E-01
96	23	0.197907E-01	96	24	0.646819E-01	96	27	-0.665688E-01
96	28	-0.112841E-01	96	29	0.440662E-01	96	32	-0.924176E-01
96	33	-0.306834E-01	96	34	0.310462E-01	96	37	-0.101247E 00
96	38	-0.373188E-01	96	39	0.266336E-01	96	42	-0.925590E-01
96	43	-0.307383E-01	96	44	0.310644E-01	96	47	-0.667316E-01
96	48	-0.113310E-01	96	49	0.441115E-01	96	52	-0.256449E-01
96	53	0.198122E-01	96	54	0.647882E-01	96	57	0.279669E-01
96	58	0.599103E-01	96	59	0.917913E-01	96	63	0.106790E 00
96	64	0.123258E 00	96	67	0.157472E 00	96	68	0.157272E 00
96	69	0.156989E 00	96	72	0.224505E 00	96	73	0.207629E 00
96	74	0.190737E 00	96	77	0.286985E 00	96	78	0.254535E 00
96	79	0.222145E 00	96	82	0.340457E 00	96	83	0.294723E 00
96	84	0.248965E 00	96	87	0.381805E 00	96	88	0.325477E 00
96	89	0.269495E 00	96	92	0.407197E 00	96	93	0.344493E 00
96	94	0.282247E 00	96	97	0.417003E 00	96	98	0.349926E 00
96	99	0.286541E 00	96	103	0.342535E 00	96	104	0.281885E 00
96	107	0.378406E 00	96	108	0.323517E 00	96	109	0.268691E 00
96	112	0.338448E 00	96	113	0.293100E 00	96	114	0.248069E 00
96	117	0.285302E 00	96	118	0.253279E 00	96	119	0.221243E 00
97	2	0.273744E 00	97	3	0.262102E 00	97	4	0.251210E 00
97	7	0.204986E 00	97	8	0.210098E 00	97	9	0.215805E 00
97	12	0.133403E 00	97	13	0.156964E 00	97	14	0.180234E 00
97	17	0.664161E-01	97	18	0.107583E 00	97	19	0.147005E 00
97	23	0.659798E-01	97	24	0.118585E 00	97	27	-0.281376E-01
97	28	0.343371E-01	97	29	0.969473E-01	97	32	-0.530326E-01
97	33	0.149503E-01	97	34	0.833625E-01	97	37	-0.614197E-01
97	38	0.835250E-02	97	39	0.787541E-01	97	42	-0.523389E-01
97	43	0.150874E-01	97	44	0.830160E-01	97	47	-0.275972E-01
97	48	0.342767E-01	97	49	0.964321E-01	97	52	0.122042E-01
97	53	0.656928E-01	97	54	0.117946E 00	97	57	0.661610E-01
97	58	0.107173E 00	97	59	0.146349E 00	97	63	0.156732E 00
97	64	0.179716E 00	97	67	0.205581E 00	97	68	0.210516E 00
97	69	0.215576E 00	97	72	0.276548E 00	97	73	0.263606E 00

97	74	0.251337E	00	97	77	0.339605E	00	97	78	0.311758E	00
97	79	0.284372E	00	97	82	0.390182E	00	97	83	0.351386E	00
97	84	0.312378E	00	97	87	0.422614E	00	97	88	0.381368E	00
97	89	0.333901E	00	97	92	0.447222E	00	97	93	0.400938E	00
97	94	0.347414E	00	97	97	0.440330E	00	97	98	0.414295E	00
97	99	0.349850E	00	97	103	0.398023E	00	97	104	0.345991E	00
97	107	0.409787E	00	97	108	0.375174E	00	97	109	0.331681E	00
97	112	0.377651E	00	97	113	0.344993E	00	97	114	0.309647E	00
97	117	0.330975E	00	97	118	0.306360E	00	97	119	0.281667E	00
98	2	0.307079E	00	98	3	0.303765E	00	98	4	0.302346E	00
98	7	0.242723E	00	98	8	0.254794E	00	98	9	0.268313E	00
98	12	0.172993E	00	98	13	0.203933E	00	98	14	0.234113E	00
98	17	0.107917E	00	98	18	0.156944E	00	98	19	0.202311E	00
98	23	0.118397E	00	98	24	0.175390E	00	98	27	0.253259E	-01
98	28	0.901138E	-01	98	29	0.155171E	00	98	32	0.513780E	-02
98	33	0.733820E	-01	98	34	0.142654E	00	98	37	-0.129870E	-02
98	38	0.678610E	-01	98	39	0.138483E	00	98	42	0.676130E	-02
98	43	0.739763E	-01	98	44	0.142469E	00	98	47	0.271013E	-01
98	48	0.905747E	-01	98	49	0.154795E	00	98	52	0.601620E	-01
98	53	0.118405E	00	98	54	0.174793E	00	98	57	0.107518E	00
98	58	0.156371E	00	98	59	0.201549E	00	98	63	0.203054E	00
98	64	0.233340E	00	98	67	0.241386E	00	98	68	0.254291E	00
98	69	0.267738E	00	98	72	0.308229E	00	98	73	0.304402E	00
98	74	0.302131E	00	98	77	0.364295E	00	98	78	0.348490E	00
98	79	0.334060E	00	98	82	0.404391E	00	98	83	0.383910E	00
98	84	0.361902E	00	98	87	0.425647E	00	98	88	0.408319E	00
98	89	0.385542E	00	98	92	0.426091E	00	98	93	0.440401E	00
98	94	0.401974E	00	98	97	0.422866E	00	98	98	0.439272E	00
98	99	0.414110E	00	98	103	0.435534E	00	98	104	0.400382E	00
98	107	0.410796E	00	98	108	0.400949E	00	98	109	0.382752E	00
98	112	0.391433E	00	98	113	0.376810E	00	98	114	0.358664E	00
98	117	0.356151E	00	98	118	0.343226E	00	98	119	0.331250E	00
99	2	0.316252E	00	99	3	0.324725E	00	99	4	0.336950E	00
99	7	0.263327E	00	99	8	0.284203E	00	99	9	0.307727E	00
99	12	0.203098E	00	99	13	0.241308E	00	99	14	0.278482E	00
99	17	0.147452E	00	99	18	0.202224E	00	99	19	0.251594E	00
99	23	0.171624E	00	99	24	0.229273E	00	99	27	0.888433E	-01
99	28	0.150602E	00	99	29	0.212912E	00	99	32	0.768172E	-01
99	33	0.139022E	00	99	34	0.203034E	00	99	37	0.735744E	-01
99	38	0.135462E	00	99	39	0.199840E	00	99	42	0.793154E	-01
99	43	0.140152E	00	99	44	0.203247E	00	99	47	0.919771E	-01
99	48	0.151765E	00	99	49	0.212958E	00	99	52	0.113072E	00
99	53	0.172178E	00	99	54	0.229036E	00	99	57	0.147135E	00
99	58	0.201763E	00	99	59	0.251053E	00	99	63	0.240029E	00
99	64	0.277759E	00	99	67	0.260196E	00	99	68	0.282934E	00
99	69	0.307054E	00	99	72	0.315653E	00	99	73	0.324480E	00
99	74	0.336559E	00	99	77	0.358444E	00	99	78	0.359495E	00
99	79	0.364151E	00	99	82	0.383926E	00	99	83	0.385457E	00
99	84	0.389053E	00	99	87	0.388655E	00	99	88	0.401668E	00
99	89	0.411986E	00	99	92	0.373306E	00	99	93	0.409789E	00
99	94	0.442363E	00	99	97	0.352747E	00	99	98	0.419245E	00
99	99	0.425789E	00	99	103	0.405879E	00	99	104	0.440997E	00
99	107	0.375823E	00	99	108	0.395498E	00	99	109	0.409684E	00
99	112	0.373095E	00	99	113	0.379591E	00	99	114	0.386416E	00
99	117	0.352599E	00	99	118	0.355691E	00	99	119	0.362102E	00
100	2	0.307596E	00	100	3	0.330236E	00	100	4	0.359491E	00
100	7	0.271008E	00	100	8	0.302324E	00	100	9	0.337994E	00

100	12	0.226014E	00	100	13	0.271777E	00	100	14	0.316496E	00
100	17	0.185579E	00	100	18	0.244836E	00	100	19	0.297167E	00
100	23	0.225951E	00	100	24	0.281783E	00	100	27	0.160250E	00
100	28	0.215195E	00	100	29	0.271124E	00	100	32	0.159072E	00
100	33	0.210697E	00	100	34	0.265082E	00	100	37	0.160002E	00
100	38	0.209798E	00	100	39	0.263297E	00	100	42	0.162634E	00
100	43	0.212467E	00	100	44	0.265725E	00	100	47	0.165002E	00
100	48	0.217207E	00	100	49	0.271651E	00	100	52	0.169997E	00
100	53	0.227209E	00	100	54	0.281974E	00	100	57	0.185524E	00
100	58	0.244625E	00	100	59	0.296904E	00	100	63	0.270194E	00
100	64	0.315846E	00	100	67	0.266215E	00	100	68	0.300306E	00
100	69	0.337190E	00	100	72	0.305173E	00	100	73	0.329008E	00
100	74	0.358817E	00	100	77	0.331224E	00	100	78	0.350930E	00
100	79	0.378686E	00	100	82	0.341301E	00	100	83	0.363978E	00
100	84	0.395801E	00	100	87	0.333529E	00	100	88	0.366104E	00
100	89	0.408701E	00	100	92	0.312512E	00	100	93	0.361956E	00
100	94	0.416047E	00	100	97	0.295703E	00	100	98	0.355807E	00
100	99	0.427553E	00	100	103	0.358865E	00	100	104	0.415006E	00
100	107	0.323378E	00	100	108	0.361373E	00	100	109	0.406947E	00
100	112	0.333148E	00	100	113	0.359591E	00	100	114	0.393832E	00
100	117	0.327983E	00	100	118	0.348847E	00	100	119	0.377591E	00
101	2	0.460876E	00	101	3	0.387560E	00	101	4	0.315899E	00
101	7	0.349813E	00	101	8	0.309775E	00	101	9	0.268736E	00
101	12	0.227967E	00	101	13	0.224299E	00	101	14	0.216118E	00
101	17	0.112338E	00	101	18	0.142353E	00	101	19	0.163675E	00
101	23	0.716965E-01	101	101	24	0.116397E	00	101	27	-0.484930E-01	101
101	28	0.164117E-01	101	101	29	0.778236E-01	101	101	32	-0.940732E-01	101
101	33	-0.211597E-01	101	101	34	0.497368E-01	101	101	37	-0.116676E	00
101	38	-0.417747E-01	101	101	39	0.328259E-01	101	101	42	-0.118201E	00
101	43	-0.461912E-01	101	101	44	0.267884E-01	101	101	47	-0.102265E	00
101	48	-0.375249E-01	101	101	49	0.296769E-01	101	101	52	-0.723450E-01	101
101	53	-0.184253E-01	101	101	54	0.400645E-01	101	101	57	-0.356998E-01	101
101	58	0.661980E-02	101	101	59	0.564039E-01	101	101	63	0.358703E-01	101
101	64	0.774518E-01	101	101	67	0.369226E-01	101	101	68	0.685874E-01	101
101	69	0.102547E	00	101	72	0.807835E-01	101	101	73	0.106044E	00
101	74	0.131587E	00	101	77	0.132542E	00	101	78	0.149553E	00
101	79	0.164697E	00	101	82	0.193260E	00	101	83	0.199158E	00
101	84	0.201353E	00	101	87	0.263159E	00	101	88	0.255684E	00
101	89	0.241895E	00	101	92	0.341053E	00	101	93	0.319065E	00
101	94	0.283914E	00	101	97	0.434488E	00	101	98	0.387811E	00
101	99	0.323126E	00	101	103	0.446335E	00	101	104	0.354345E	00
101	107	0.608405E	00	101	108	0.482687E	00	101	109	0.371395E	00
101	112	0.602373E	00	101	113	0.482047E	00	101	114	0.370936E	00
101	117	0.548583E	00	101	118	0.448016E	00	101	119	0.351495E	00
102	2	0.452407E	00	102	3	0.397234E	00	102	4	0.343503E	00
102	7	0.352149E	00	102	8	0.325687E	00	102	9	0.298824E	00
102	12	0.240326E	00	102	13	0.247109E	00	102	14	0.249706E	00
102	17	0.134183E	00	102	18	0.172121E	00	102	19	0.201209E	00
102	23	0.108219E	00	102	24	0.157873E	00	102	27	-0.772610E-02	102
102	28	0.589435E-01	102	102	29	0.122872E	00	102	32	-0.469273E-01	102
102	33	0.259946E-01	102	102	34	0.977440E-01	102	102	37	-0.660484E-01	102
102	38	0.830520E-02	102	102	39	0.830647E-01	102	102	42	-0.653515E-01	102
102	43	0.552870E-02	102	102	44	0.777430E-01	102	102	47	-0.510288E-01	102
102	48	0.141544E-01	102	102	49	0.816042E-01	102	102	52	-0.238884E-01	102
102	53	0.330141E-01	102	102	54	0.928540E-01	102	102	57	0.117315E-01	102
102	58	0.588059E-01	102	102	59	0.110207E	00	102	63	0.901023E-01	102
102	64	0.132404E	00	102	67	0.943236E-01	102	102	68	0.125314E	00

102	69	0.158414E	00	102	72	0.141269E	00	102	73	0.163914E	00
102	74	0.187559E	00	102	77	0.191172E	00	102	78	0.205625E	00
102	79	0.219399E	00	102	82	0.243264E	00	102	83	0.249484E	00
102	84	0.252779E	00	102	87	0.298333E	00	102	88	0.296968E	00
102	89	0.288933E	00	102	92	0.354101E	00	102	93	0.350313E	00
102	94	0.325631E	00	102	97	0.434609E	00	102	98	0.409367E	00
102	99	0.359189E	00	102	103	0.464259E	00	102	104	0.383441E	00
102	107	0.577642E	00	102	108	0.485587E	00	102	109	0.396981E	00
102	112	0.564814E	00	102	113	0.479753E	00	102	114	0.393255E	00
102	117	0.522771E	00	102	118	0.446821E	00	102	119	0.372979E	00
103	2	0.429170E	00	103	3	0.396709E	00	103	4	0.366268E	00
103	7	0.345408E	00	103	8	0.335536E	00	103	9	0.326221E	00
103	12	0.249399E	00	103	13	0.268051E	00	103	14	0.283057E	00
103	17	0.158228E	00	103	18	0.204053E	00	103	19	0.240966E	00
103	23	0.150517E	00	103	24	0.203801E	00	103	27	0.444114E-01	
103	28	0.110183E	00	103	29	0.174169E	00	103	32	0.142904E-01	
103	33	0.838087E-01		103	34	0.153223E	00	103	37	-0.265900E-03	
103	38	0.698768E-01		103	39	0.141333E	00	103	42	0.160000E-05	
103	43	0.679797E-01		103	44	0.137838E	00	103	47	0.113955E-01	
103	48	0.757604E-01		103	49	0.142294E	00	103	52	0.335818E-01	
103	53	0.930569E-01		103	54	0.153726E	00	103	57	0.657436E-01	
103	58	0.118066E	00	103	59	0.171224E	00	103	63	0.149871E	00
103	64	0.193617E	00	103	67	0.154601E	00	103	68	0.186083E	00
103	69	0.219574E	00	103	72	0.202729E	00	103	73	0.224323E	00
103	74	0.247884E	00	103	77	0.248617E	00	103	78	0.262648E	00
103	79	0.277589E	00	103	82	0.290733E	00	103	83	0.300047E	00
103	84	0.308083E	00	103	87	0.327600E	00	103	88	0.336862E	00
103	89	0.339676E	00	103	92	0.359663E	00	103	93	0.375819E	00
103	94	0.372943E	00	103	97	0.402755E	00	103	98	0.435669E	00
103	99	0.403419E	00	103	103	0.468403E	00	103	104	0.430646E	00
103	107	0.511666E	00	103	108	0.491207E	00	103	109	0.429725E	00
103	112	0.514839E	00	103	113	0.468406E	00	103	114	0.419377E	00
103	117	0.485625E	00	103	118	0.440450E	00	103	119	0.395970E	00
104	2	0.391611E	00	104	3	0.384024E	00	104	4	0.380327E	00
104	7	0.328203E	00	104	8	0.336476E	00	104	9	0.346997E	00
104	12	0.252531E	00	104	13	0.283594E	00	104	14	0.311905E	00
104	17	0.181071E	00	104	18	0.234047E	00	104	19	0.278315E	00
104	23	0.194038E	00	104	24	0.249230E	00	104	27	0.103291E	00
104	28	0.165236E	00	104	29	0.226505E	00	104	32	0.846999E-01	
104	33	0.147154E	00	104	34	0.210748E	00	104	37	0.757133E-01	
104	38	0.137647E	00	104	39	0.202000E	00	104	42	0.758304E-01	
104	43	0.136621E	00	104	44	0.200045E	00	104	47	0.818563E-01	
104	48	0.141754E	00	104	49	0.203918E	00	104	52	0.951236E-01	
104	53	0.154579E	00	104	54	0.213696E	00	104	57	0.118703E	00
104	58	0.175095E	00	104	59	0.228992E	00	104	63	0.203194E	00
104	64	0.248939E	00	104	67	0.202092E	00	104	68	0.236041E	00
104	69	0.272149E	00	104	72	0.245846E	00	104	73	0.269818E	00
104	74	0.297098E	00	104	77	0.283132E	00	104	78	0.301204E	00
104	79	0.322508E	00	104	82	0.311438E	00	104	83	0.328762E	00
104	84	0.347765E	00	104	87	0.329140E	00	104	88	0.352299E	00
104	89	0.373579E	00	104	92	0.337169E	00	104	93	0.376357E	00
104	94	0.401908E	00	104	97	0.349443E	00	104	98	0.403032E	00
104	99	0.441032E	00	104	103	0.435684E	00	104	104	0.434412E	00
104	107	0.428211E	00	104	108	0.440938E	00	104	109	0.457788E	00
104	112	0.444198E	00	104	113	0.437622E	00	104	114	0.430776E	00
104	117	0.430807E	00	104	118	0.417163E	00	104	119	0.407146E	00
105	2	0.340938E	00	105	3	0.358381E	00	105	4	0.383796E	00

105	7	0.301050E	00	105	8	0.328261E	00	105	9	0.360434E	00
105	12	0.250093E	00	105	13	0.293748E	00	105	14	0.336044E	00
105	17	0.203086E	00	105	18	0.262277E	00	105	19	0.313263E	00
105	23	0.239046E	00	105	24	0.294240E	00	105	27	0.169411E	00
105	28	0.224401E	00	105	29	0.279967E	00	105	32	0.164813E	00
105	33	0.216324E	00	105	34	0.270385E	00	105	37	0.162365E	00
105	38	0.211872E	00	105	39	0.265090E	00	105	42	0.161479E	00
105	43	0.210975E	00	105	44	0.264043E	00	105	47	0.159845E	00
105	48	0.211766E	00	105	49	0.266231E	00	105	52	0.160458E	00
105	53	0.217388E	00	105	54	0.272638E	00	105	57	0.170618E	00
105	58	0.229917E	00	105	59	0.283540E	00	105	63	0.250327E	00
105	64	0.298559E	00	105	67	0.237475E	00	105	68	0.275646E	00
105	69	0.316445E	00	105	72	0.271673E	00	105	73	0.301001E	00
105	74	0.335504E	00	105	77	0.296316E	00	105	78	0.321953E	00
105	79	0.354158E	00	105	82	0.309114E	00	105	83	0.337010E	00
105	84	0.371755E	00	105	87	0.308351E	00	105	88	0.344835E	00
105	89	0.387581E	00	105	92	0.297711E	00	105	93	0.349409E	00
105	94	0.402451E	00	105	97	0.292580E	00	105	98	0.355509E	00
105	99	0.414136E	00	105	103	0.363722E	00	105	104	0.430950E	00
105	107	0.343768E	00	105	108	0.377691E	00	105	109	0.422650E	00
105	112	0.361684E	00	105	113	0.383197E	00	105	114	0.416336E	00
105	117	0.360999E	00	105	118	0.376491E	00	105	119	0.402124E	00
106	2	0.702617E	00	106	3	0.571332E	00	106	4	0.444404E	00
106	7	0.549500E	00	106	8	0.468202E	00	106	9	0.385726E	00
106	12	0.372889E	00	106	13	0.348555E	00	106	14	0.315341E	00
106	17	0.203188E	00	106	18	0.231594E	00	106	19	0.242485E	00
106	23	0.130116E	00	106	24	0.175179E	00	106	27	-0.250763E	-01
106	28	0.504362E	-01	106	29	0.118882E	00	106	32	-0.908117E	-01
106	33	-0.531570E	-02	106	34	0.760612E	-01	106	37	-0.127150E	00
106	38	-0.395103E	-01	106	39	0.472723E	-01	106	42	-0.137273E	00
106	43	-0.537283E	-01	106	44	0.313885E	-01	106	47	-0.129329E	00
106	48	-0.540053E	-01	106	49	0.256225E	-01	106	52	-0.107442E	00
106	53	-0.441316E	-01	106	54	0.277459E	-01	106	57	-0.828282E	-01
106	58	-0.302297E	-01	106	59	0.358486E	-01	106	63	-0.139730E	-01
106	64	0.489819E	-01	106	67	-0.519986E	-01	106	68	0.550400E	-02
106	69	0.675000E	-01	106	72	-0.255841E	-01	106	73	0.331271E	-01
106	74	0.928183E	-01	106	77	0.176245E	-01	106	78	0.736437E	-01
106	79	0.126892E	00	106	82	0.817345E	-01	106	83	0.128689E	00
106	84	0.169734E	00	106	87	0.172109E	00	106	88	0.203382E	00
106	89	0.224916E	00	106	92	0.286978E	00	106	93	0.297983E	00
106	94	0.289143E	00	106	97	0.436753E	00	106	98	0.411031E	00
106	99	0.357025E	00	106	103	0.526150E	00	106	104	0.419599E	00
106	107	0.807460E	00	106	108	0.617566E	00	106	109	0.465842E	00
106	112	0.851976E	00	106	113	0.657794E	00	106	114	0.486916E	00
106	117	0.807049E	00	106	118	0.637398E	00	106	119	0.478348E	00
107	2	0.637651E	00	107	3	0.536763E	00	107	4	0.439250E	00
107	7	0.506734E	00	107	8	0.447253E	00	107	9	0.386803E	00
107	12	0.354222E	00	107	13	0.343463E	00	107	14	0.324864E	00
107	17	0.207359E	00	107	18	0.242358E	00	107	19	0.261249E	00
107	23	0.155306E	00	107	24	0.202839E	00	107	27	0.152216E	-01
107	28	0.875708E	-01	107	29	0.154270E	00	107	32	-0.393581E	-01
107	33	0.405590E	-01	107	34	0.117587E	00	107	37	-0.695513E	-01
107	38	0.118728E	-01	107	39	0.932261E	-01	107	42	-0.777119E	-01
107	43	0.373400E	-03	107	44	0.802678E	-01	107	47	-0.710219E	-01
107	48	0.826900E	-03	107	49	0.764180E	-01	107	52	-0.520047E	-01
107	53	0.109164E	-01	107	54	0.800297E	-01	107	57	-0.281168E	-01
107	58	0.261181E	-01	107	59	0.895727E	-01	107	63	0.451377E	-01

107	64	0.104093E	00	107	67	0.160554E-01	107	68	0.678025E-01		
107	69	0.123450E	00	107	72	0.467130E-01	107	73	0.966753E-01		
107	74	0.148254E	00	107	77	0.878652E-01	107	78	0.134340E	00	
107	79	0.179587E	00	107	82	0.141888E	00	107	83	0.181656E	00
107	84	0.217292E	00	107	87	0.212285E	00	107	88	0.242438E	00
107	89	0.264157E	00	107	92	0.298319E	00	107	93	0.318463E	00
107	94	0.318106E	00	107	97	0.413000E	00	107	98	0.411123E	00
107	99	0.375121E	00	107	103	0.509878E	00	107	104	0.427212E	00
107	107	0.715519E	00	107	108	0.593540E	00	107	109	0.463427E	00
107	112	0.765049E	00	107	113	0.616578E	00	107	114	0.480866E	00
107	117	0.722127E	00	107	118	0.595087E	00	107	119	0.470615E	00
108	2	0.552508E	00	108	3	0.491842E	00	108	4	0.432341E	00
108	7	0.451206E	00	108	8	0.419344E	00	108	9	0.387213E	00
108	12	0.329536E	00	108	13	0.335913E	00	108	14	0.335707E	00
108	17	0.212224E	00	108	18	0.255137E	00	108	19	0.283716E	00
108	23	0.186627E	00	108	24	0.236530E	00	108	27	0.668907E-01	
108	28	0.134198E	00	108	29	0.197651E	00	108	32	0.266365E-01	
108	33	0.982122E-01		108	34	0.168496E	00	108	37	0.399260E-02	
108	38	0.761229E-01		108	39	0.149276E	00	108	42	-0.267130E-02	
108	43	0.672014E-01		108	44	0.139335E	00	108	47	0.986300E-03	
108	48	0.673054E-01		108	49	0.136873E	00	108	52	0.142955E-01	
108	53	0.758721E-01		108	54	0.141045E	00	108	57	0.344003E-01	
108	58	0.904326E-01		108	59	0.150872E	00	108	63	0.110357E	00
108	64	0.165547E	00	108	67	0.877811E-01		108	68	0.134525E	00
108	69	0.184529E	00	108	72	0.120858E	00	108	73	0.163066E	00
108	74	0.207650E	00	108	77	0.158062E	00	108	78	0.196272E	00
108	79	0.235125E	00	108	82	0.200036E	00	108	83	0.234259E	00
108	84	0.266700E	00	108	87	0.248273E	00	108	88	0.279204E	00
108	89	0.304274E	00	108	92	0.302790E	00	108	93	0.334373E	00
108	94	0.347305E	00	108	97	0.378223E	00	108	98	0.401457E	00
108	99	0.394701E	00	108	103	0.491580E	00	108	104	0.438734E	00
108	107	0.599692E	00	108	108	0.545651E	00	108	109	0.475535E	00
108	112	0.633340E	00	108	113	0.573311E	00	108	114	0.477527E	00
108	117	0.615545E	00	108	118	0.538466E	00	108	119	0.463077E	00
109	2	0.463267E	00	109	3	0.441746E	00	109	4	0.424096E	00
109	7	0.392143E	00	109	8	0.380325E	00	109	9	0.387262E	00
109	12	0.303059E	00	109	13	0.327362E	00	109	14	0.347136E	00
109	17	0.217273E	00	109	18	0.268520E	00	109	19	0.307621E	00
109	23	0.220044E	00	109	24	0.272439E	00	109	27	0.122622E	00
109	28	0.184196E	00	109	29	0.243889E	00	109	32	0.980632E-01	
109	33	0.160126E	00	109	34	0.222677E	00	109	37	0.836163E-01	
109	38	0.145002E	00	109	39	0.208704E	00	109	42	0.782433E-01	
109	43	0.138528E	00	109	44	0.201733E	00	109	47	0.777224E-01	
109	48	0.137412E	00	109	49	0.200059E	00	109	52	0.833399E-01	
109	53	0.143011E	00	109	54	0.203876E	00	109	57	0.970436E-01	
109	58	0.155066E	00	109	59	0.212841E	00	109	63	0.173799E	00
109	64	0.226415E	00	109	67	0.153691E	00	109	68	0.197347E	00
109	69	0.243800E	00	109	72	0.186498E	00	109	73	0.223668E	00
109	74	0.264193E	00	109	77	0.217729E	00	109	78	0.250968E	00
109	79	0.287061E	00	109	82	0.246731E	00	109	83	0.278796E	00
109	84	0.312149E	00	109	87	0.273029E	00	109	88	0.307661E	00
109	89	0.340331E	00	109	92	0.297936E	00	109	93	0.341334E	00
109	94	0.372586E	00	109	97	0.334808E	00	109	98	0.384070E	00
109	99	0.409765E	00	109	103	0.432262E	00	109	104	0.457836E	00
109	107	0.463935E	00	109	108	0.480323E	00	109	109	0.457502E	00
109	112	0.503352E	00	109	113	0.488090E	00	109	114	0.482747E	00
109	117	0.501586E	00	109	118	0.475724E	00	109	119	0.452678E	00

110	2	0.370012E	00	110	3	0.383543E	00	110	4	0.407136E	00
110	7	0.328783E	00	110	8	0.352874E	00	110	9	0.382974E	00
110	12	0.273758E	00	110	13	0.315906E	00	110	14	0.356600E	00
110	17	0.221930E	00	110	18	0.281258E	00	110	19	0.331193E	00
110	23	0.254863E	00	110	24	0.309260E	00	110	27	0.182878E	00
110	28	0.237293E	00	110	29	0.291970E	00	110	32	0.175758E	00
110	33	0.226305E	00	110	34	0.279281E	00	110	37	0.170340E	00
110	38	0.218638E	00	110	39	0.270724E	00	110	42	0.165809E	00
110	43	0.214141E	00	110	44	0.266235E	00	110	47	0.159709E	00
110	48	0.210728E	00	110	49	0.264597E	00	110	52	0.155167E	00
110	53	0.211549E	00	110	54	0.266892E	00	110	57	0.159203E	00
110	58	0.218728E	00	110	59	0.273503E	00	110	63	0.233526E	00
110	64	0.284289E	00	110	67	0.211336E	00	110	68	0.253568E	00
110	69	0.298351E	00	110	72	0.240112E	00	110	73	0.274936E	00
110	74	0.314384E	00	110	77	0.262327E	00	110	78	0.293980E	00
110	79	0.331202E	00	110	82	0.276383E	00	110	83	0.309685E	00
110	84	0.348349E	00	110	87	0.280961E	00	110	88	0.321203E	00
110	89	0.365556E	00	110	92	0.279276E	00	110	93	0.332585E	00
110	94	0.383857E	00	110	97	0.285127E	00	110	98	0.347629E	00
110	99	0.403188E	00	110	103	0.367436E	00	110	104	0.419869E	00
110	107	0.357836E	00	110	108	0.385294E	00	110	109	0.440232E	00
110	112	0.383460E	00	110	113	0.400543E	00	110	114	0.432771E	00
110	117	0.388213E	00	110	118	0.399340E	00	110	119	0.424375E	00
111	2	0.921468E	00	111	3	0.728808E	00	111	4	0.548183E	00
111	7	0.734220E	00	111	8	0.609194E	00	111	9	0.484643E	00
111	12	0.509920E	00	111	13	0.461980E	00	111	14	0.401931E	00
111	17	0.291457E	00	111	18	0.315071E	00	111	19	0.312950E	00
111	23	0.186496E	00	111	24	0.228947E	00	111	27	0.222850E-02	
111	28	0.851182E-01		111	29	0.157505E	00	111	32	-0.820552E-01	
111	33	0.131412E-01		111	34	0.102030E	00	111	37	-0.130984E	00
111	38	-0.330048E-01		111	39	0.631888E-01		111	42	-0.149011E	00
111	43	-0.555159E-01		111	44	0.395702E-01		111	47	-0.146809E	00
111	48	-0.624392E-01		111	49	0.272400E-01		111	52	-0.129671E	00
111	53	-0.586567E-01		111	54	0.235192E-01		111	57	-0.112016E	00
111	58	-0.517635E-01		111	59	0.260246E-01		111	63	-0.437999E-01	
111	64	0.337459E-01		111	67	-0.107620E	00	111	68	-0.332524E-01	
111	69	0.474577E-01		111	72	-0.936406E-01		111	73	-0.131448E-01	
111	74	0.693766E-01		111	77	-0.585779E-01		111	78	0.233106E-01	
111	79	0.102553E	00	111	82	0.417990E-02		111	83	0.793021E-01	
111	84	0.147853E	00	111	87	0.102058E	00	111	88	0.161693E	00
111	89	0.210184E	00	111	92	0.233712E	00	111	93	0.271565E	00
111	94	0.286655E	00	111	97	0.410161E	00	111	98	0.407618E	00
111	99	0.372375E	00	111	103	0.558057E	00	111	104	0.457240E	00
111	107	0.883563E	00	111	108	0.695218E	00	111	109	0.527605E	00
111	112	0.103961E	01	111	113	0.778615E	00	111	114	0.570810E	00
111	117	0.103618E	01	111	118	0.790214E	00	111	119	0.576677E	00
112	2	0.794403E	00	112	3	0.654037E	00	112	4	0.515909E	00
112	7	0.644721E	00	112	8	0.553152E	00	112	9	0.461190E	00
112	12	0.459384E	00	112	13	0.430858E	00	112	14	0.391166E	00
112	17	0.278916E	00	112	18	0.309184E	00	112	19	0.316543E	00
112	23	0.203407E	00	112	24	0.246425E	00	112	27	0.457453E-01	
112	28	0.120481E	00	112	29	0.186917E	00	112	32	-0.219764E-01	
112	33	0.615977E-01		112	34	0.140661E	00	112	37	-0.621677E-01	
112	38	0.233184E-01		112	39	0.108107E	00	112	42	-0.782583E-01	
112	43	0.405570E-02		112	44	0.882764E-01		112	47	-0.788634E-01	
112	48	-0.284070E-02		112	49	0.777578E-01		112	52	-0.672641E-01	
112	53	-0.356800E-03		112	54	0.748333E-01		112	57	-0.530798E-01	

112	58	0.613310E-02	112	59	0.777652E-01	112	63	0.153234E-01
112	64	0.857471E-01	112	67	-0.381978E-01	112	68	0.278603E-01
112	69	0.991691E-01	112	72	-0.206143E-01	112	73	0.482563E-01
112	74	0.119432E 00	112	77	0.120511E-01	112	78	0.809104E-01
112	79	0.148596E 00	112	82	0.644722E-01	112	83	0.128088E 00
112	84	0.187267E 00	112	87	0.141646E 00	112	88	0.194671E 00
112	89	0.239039E 00	112	92	0.243090E 00	112	93	0.282581E 00
112	94	0.302069E 00	112	97	0.380617E 00	112	98	0.391945E 00
112	99	0.372869E 00	112	103	0.515002E 00	112	104	0.443601E 00
112	107	0.765832E 00	112	108	0.631725E 00	112	109	0.502346E 00
112	112	0.889278E 00	112	113	0.710564E 00	112	114	0.536054E 00
112	117	0.893579E 00	112	118	0.709300E 00	112	119	0.541736E 00
113	2	0.656658E 00	113	3	0.571854E 00	113	4	0.488737E 00
113	7	0.544443E 00	113	8	0.493774E 00	113	9	0.441063E 00
113	12	0.403691E 00	113	13	0.398631E 00	113	14	0.384198E 00
113	17	0.265610E 00	113	18	0.305114E 00	113	19	0.325042E 00
113	23	0.224871E 00	113	24	0.270187E 00	113	27	0.959008E-01
113	28	0.162776E 00	113	29	0.223941E 00	113	32	0.472378E-01
113	33	0.118810E 00	113	34	0.188017E 00	113	37	0.173111E-01
113	38	0.895987E-01	113	39	0.162556E 00	113	42	0.384290E-02
113	43	0.742204E-01	113	44	0.147007E 00	113	47	0.109200E-03
113	48	0.673540E-01	113	49	0.138490E 00	113	52	0.525850E-02
113	53	0.682510E-01	113	54	0.136384E 00	113	57	0.151532E-01
113	58	0.740651E-01	113	59	0.139683E 00	113	63	0.843681E-01
113	64	0.147831E 00	113	67	0.410431E-01	113	68	0.988584E-01
113	69	0.160813E 00	113	72	0.622390E-01	113	73	0.119319E 00
113	74	0.179149E 00	113	77	0.917908E-01	113	78	0.147507E 00
113	79	0.203829E 00	113	82	0.132146E 00	113	83	0.184558E 00
113	84	0.235056E 00	113	87	0.186047E 00	113	88	0.233568E 00
113	89	0.275379E 00	113	92	0.253848E 00	113	93	0.297183E 00
113	94	0.324051E 00	113	97	0.347781E 00	113	98	0.377428E 00
113	99	0.379299E 00	113	103	0.468810E 00	113	104	0.436921E 00
113	107	0.618587E 00	113	108	0.573467E 00	113	109	0.485959E 00
113	112	0.716813E 00	113	113	0.623254E 00	113	114	0.521134E 00
113	117	0.717435E 00	113	118	0.632043E 00	113	119	0.514501E 00
114	2	0.520236E 00	114	3	0.490884E 00	114	4	0.464199E 00
114	7	0.446964E 00	114	8	0.435188E 00	114	9	0.424547E 00
114	12	0.349329E 00	114	13	0.368263E 00	114	14	0.380845E 00
114	17	0.253344E 00	114	18	0.302956E 00	114	19	0.337088E 00
114	23	0.248397E 00	114	24	0.297365E 00	114	27	0.147453E 00
114	28	0.207329E 00	114	29	0.264279E 00	114	32	0.118357E 00
114	33	0.178505E 00	114	34	0.238596E 00	114	37	0.991061E-01
114	38	0.158497E 00	114	39	0.220107E 00	114	42	0.882365E-01
114	43	0.146834E 00	114	44	0.208539E 00	114	47	0.811087E-01
114	48	0.139714E 00	114	49	0.201735E 00	114	52	0.790614E-01
114	53	0.138432E 00	114	54	0.200016E 00	114	57	0.834659E-01
114	58	0.142697E 00	114	59	0.203130E 00	114	63	0.153048E 00
114	64	0.210824E 00	114	67	0.117160E 00	114	68	0.168354E 00
114	69	0.222763E 00	114	72	0.140410E 00	114	73	0.187854E 00
114	74	0.238679E 00	114	77	0.165672E 00	114	78	0.210833E 00
114	79	0.258596E 00	114	82	0.193542E 00	114	83	0.237530E 00
114	84	0.282515E 00	114	87	0.224486E 00	114	88	0.269018E 00
114	89	0.311609E 00	114	92	0.259989E 00	114	93	0.308760E 00
114	94	0.346319E 00	114	97	0.312296E 00	114	98	0.359625E 00
114	99	0.386549E 00	114	103	0.420602E 00	114	104	0.430877E 00
114	107	0.482157E 00	114	108	0.479844E 00	114	109	0.482801E 00
114	112	0.536416E 00	114	113	0.525858E 00	114	114	0.481672E 00

114	117	0.552198E	00	114	118	0.520349E	00	114	119	0.501342E	00
115	2	0.391660E	00	115	3	0.402661E	00	115	4	0.427288E	00
115	7	0.351460E	00	115	8	0.373839E	00	115	9	0.404007E	00
115	12	0.295001E	00	115	13	0.336527E	00	115	14	0.376955E	00
115	17	0.240843E	00	115	18	0.300581E	00	115	19	0.350046E	00
115	23	0.272623E	00	115	24	0.326182E	00	115	27	0.200729E	00
115	28	0.253391E	00	115	29	0.306674E	00	115	32	0.191710E	00
115	33	0.240369E	00	115	34	0.291474E	00	115	37	0.183872E	00
115	38	0.229977E	00	115	39	0.280033E	00	115	42	0.175907E	00
115	43	0.222166E	00	115	44	0.272414E	00	115	47	0.164980E	00
115	48	0.214416E	00	115	49	0.266975E	00	115	52	0.154699E	00
115	53	0.210160E	00	115	54	0.265087E	00	115	57	0.152025E	00
115	58	0.211730E	00	115	59	0.267284E	00	115	63	0.220731E	00
115	64	0.273681E	00	115	67	0.189408E	00	115	68	0.235323E	00
115	69	0.283709E	00	115	72	0.212568E	00	115	73	0.252378E	00
115	74	0.296404E	00	115	77	0.231705E	00	115	78	0.268861E	00
115	79	0.310897E	00	115	82	0.245840E	00	115	83	0.284166E	00
115	84	0.326902E	00	115	87	0.253878E	00	115	88	0.297685E	00
115	89	0.344329E	00	115	92	0.258851E	00	115	93	0.313372E	00
115	94	0.364220E	00	115	97	0.273399E	00	115	98	0.334833E	00
115	99	0.386769E	00	115	103	0.362345E	00	115	104	0.410463E	00
115	107	0.362026E	00	115	108	0.390129E	00	115	109	0.429769E	00
115	112	0.396378E	00	115	113	0.407321E	00	115	114	0.449952E	00
115	117	0.406273E	00	115	118	0.414242E	00	115	119	0.439463E	00
116	2	0.105771E	01	116	3	0.811014E	00	116	4	0.596139E	00
116	7	0.863333E	00	116	8	0.697883E	00	116	9	0.539163E	00
116	12	0.614438E	00	116	13	0.542159E	00	116	14	0.456420E	00
116	17	0.368336E	00	116	18	0.381428E	00	116	19	0.362503E	00
116	23	0.238823E	00	116	24	0.271170E	00	116	27	0.460252E	-01
116	28	0.125429E	00	116	29	0.191835E	00	116	32	-0.499596E	-01
116	33	0.434122E	-01	116	34	0.128836E	00	116	37	-0.108834E	00
116	38	-0.114985E	-01	116	39	0.831351E	-01	116	42	-0.135513E	00
116	43	-0.415755E	-01	116	44	0.535489E	-01	116	47	-0.141181E	00
116	48	-0.556147E	-01	116	49	0.353448E	-01	116	52	-0.131526E	00
116	53	-0.587862E	-01	116	54	0.259670E	-01	116	57	-0.122167E	00
116	58	-0.591443E	-01	116	59	0.228801E	-01	116	63	-0.588953E	-01
116	64	0.250745E	-01	116	67	-0.138904E	00	116	68	-0.563226E	-01
116	69	0.334936E	-01	116	72	-0.155189E	00	116	73	-0.436578E	-01
116	74	0.506556E	-01	116	77	-0.108804E	00	116	78	-0.133600E	-01
116	79	0.800509E	-01	116	82	-0.517434E	-01	116	83	0.387444E	-01
116	84	0.123188E	00	116	87	0.434798E	-01	116	88	0.119499E	00
116	89	0.184991E	00	116	92	0.176358E	00	116	93	0.230482E	00
116	94	0.263226E	00	116	97	0.356206E	00	116	98	0.370169E	00
116	99	0.353807E	00	116	103	0.528569E	00	116	104	0.447757E	00
116	107	0.839143E	00	116	108	0.684647E	00	116	109	0.531537E	00
116	112	0.104078E	01	116	113	0.801652E	00	116	114	0.590641E	00
116	117	0.113734E	01	116	118	0.845480E	00	116	119	0.613370E	00
117	2	0.907790E	00	117	3	0.723621E	00	117	4	0.555643E	00
117	7	0.742996E	00	117	8	0.626260E	00	117	9	0.507059E	00
117	12	0.543188E	00	117	13	0.496719E	00	117	14	0.437338E	00
117	17	0.342484E	00	117	18	0.365157E	00	117	19	0.359084E	00
117	23	0.249266E	00	117	24	0.283528E	00	117	27	0.869418E	-01
117	28	0.157637E	00	117	29	0.218013E	00	117	32	0.107389E	-01
117	33	0.911502E	-01	117	34	0.165800E	00	117	37	-0.374200E	-01
117	38	0.456997E	-01	117	39	0.127487E	00	117	42	-0.612429E	-01
117	43	0.196764E	-01	117	44	0.102272E	00	117	47	-0.698460E	-01
117	48	0.577270E	-02	117	49	0.860985E	-01	117	52	-0.665025E	-01

117	53	0.968800E-03	117	54	0.774500E-01	117	57	-0.615324E-01
117	58	-0.274300E-03	117	59	0.745708E-01	117	63	0.792700E-03
117	64	0.767798E-01	117	67	-0.684864E-01	117	68	0.517000E-02
117	69	0.847281E-01	117	72	-0.609298E-01	117	73	0.182099E-01
117	74	0.100162E 00	117	77	-0.362593E-01	117	78	0.450458E-01
117	79	0.125574E 00	117	82	0.113300E-01	117	83	0.886896E-01
117	84	0.162006E 00	117	87	0.871829E-01	117	88	0.154221E 00
117	89	0.213238E 00	117	92	0.191327E 00	117	93	0.243657E 00
117	94	0.277744E 00	117	97	0.333572E 00	117	98	0.356665E 00
117	99	0.352497E 00	117	103	0.485868E 00	117	104	0.430540E 00
117	107	0.726637E 00	117	108	0.615251E 00	117	109	0.500932E 00
117	112	0.893584E 00	117	113	0.715746E 00	117	114	0.551100E 00
117	117	0.966008E 00	117	118	0.762594E 00	117	119	0.568392E 00
118	2	0.722226E 00	118	3	0.638341E 00	118	4	0.521664E 00
118	7	0.612404E 00	118	8	0.547125E 00	118	9	0.479485E 00
118	12	0.463200E 00	118	13	0.448884E 00	118	14	0.421612E 00
118	17	0.314352E 00	118	18	0.349292E 00	118	19	0.359902E 00
118	23	0.263206E 00	118	24	0.301419E 00	118	27	0.133531E 00
118	28	0.195893E 00	118	29	0.251071E 00	118	32	0.797895E-01
118	33	0.146887E 00	118	34	0.210791E 00	118	37	0.440155E-01
118	38	0.112196E 00	118	39	0.180710E 00	118	42	0.237368E-01
118	43	0.908929E-01	118	44	0.160405E 00	118	47	0.120698E-01
118	48	0.772665E-01	118	49	0.146527E 00	118	52	0.839540E-02
118	53	0.706884E-01	118	54	0.138705E 00	118	57	0.838200E-02
118	58	0.684412E-01	118	59	0.136047E 00	118	63	0.703654E-01
118	64	0.138241E 00	118	67	0.122104E-01	118	68	0.766537E-01
118	69	0.145616E 00	118	72	0.238186E-01	118	73	0.899543E-01
118	74	0.159068E 00	118	77	0.462134E-01	118	78	0.112722E 00
118	79	0.179991E 00	118	82	0.828568E-01	118	83	0.146749E 00
118	84	0.208969E 00	118	87	0.136735E 00	118	88	0.195150E 00
118	89	0.248506E 00	118	92	0.208584E 00	118	93	0.260516E 00
118	94	0.297950E 00	118	97	0.308773E 00	118	98	0.343790E 00
118	99	0.355581E 00	118	103	0.440870E 00	118	104	0.416858E 00
118	107	0.595893E 00	118	108	0.538613E 00	118	109	0.474980E 00
118	112	0.711043E 00	118	113	0.632096E 00	118	114	0.518187E 00
113	117	0.768925E 00	118	118	0.657870E 00	118	119	0.541534E 00
119	2	0.551307E 00	119	3	0.521439E 00	119	4	0.503886E 00
119	7	0.484128E 00	119	8	0.470258E 00	119	9	0.455779E 00
119	12	0.385952E 00	119	13	0.402148E 00	119	14	0.410182E 00
119	17	0.286635E 00	119	18	0.334877E 00	119	19	0.364535E 00
119	23	0.278075E 00	119	24	0.322654E 00	119	27	0.178774E 00
119	28	0.234761E 00	119	29	0.287048E 00	119	32	0.147523E 00
119	33	0.203173E 00	119	34	0.258423E 00	119	37	0.124540E 00
119	38	0.179403E 00	119	39	0.236452E 00	119	42	0.108281E 00
119	43	0.163005E 00	119	44	0.220950E 00	119	47	0.940832E-01
119	48	0.149929E 00	119	49	0.209395E 00	119	52	0.837451E-01
119	53	0.141764E 00	119	54	0.202424E 00	119	57	0.788184E-01
119	58	0.138541E 00	119	59	0.199977E 00	119	63	0.141187E 00
119	64	0.202097E 00	119	67	0.927401E-01	119	68	0.149105E 00
119	69	0.208808E 00	119	72	0.107782E 00	119	73	0.162320E 00
119	74	0.220196E 00	119	77	0.127276E 00	119	78	0.180706E 00
119	79	0.236621E 00	119	82	0.152607E 00	119	83	0.204984E 00
119	84	0.258295E 00	119	87	0.184502E 00	119	88	0.236311E 00
119	89	0.286406E 00	119	92	0.224670E 00	119	93	0.277922E 00
119	94	0.321224E 00	119	97	0.283949E 00	119	98	0.332008E 00
119	99	0.362236E 00	119	103	0.396774E 00	119	104	0.407254E 00
119	107	0.471559E 00	119	108	0.464041E 00	119	109	0.452739E 00

119	112	0.542838E	00	119	113	0.516706E	00	119	114	0.501353E	00
119	117	0.568759E	00	119	118	0.546237E	00	119	119	0.492664E	00
120	2	0.402988E	00	120	3	0.412956E	00	120	4	0.439687E	00
120	7	0.366310E	00	120	8	0.388405E	00	120	9	0.421595E	00
120	12	0.311716E	00	120	13	0.353769E	00	120	14	0.395889E	00
120	17	0.258568E	00	120	18	0.319085E	00	120	19	0.369066E	00
120	23	0.291715E	00	120	24	0.344580E	00	120	27	0.221335E	00
120	28	0.272494E	00	120	29	0.323909E	00	120	32	0.212872E	00
120	33	0.258595E	00	120	34	0.306985E	00	120	37	0.203364E	00
120	38	0.246153E	00	120	39	0.293179E	00	120	42	0.192073E	00
120	43	0.235250E	00	120	44	0.282692E	00	120	47	0.176027E	00
120	48	0.223120E	00	120	49	0.273567E	00	120	52	0.159429E	00
120	53	0.213601E	00	120	54	0.267509E	00	120	57	0.149638E	00
120	58	0.209424E	00	120	59	0.265257E	00	120	63	0.212602E	00
120	64	0.267207E	00	120	67	0.172776E	00	120	68	0.221769E	00
120	69	0.273096E	00	120	72	0.190429E	00	120	73	0.234390E	00
120	74	0.282234E	00	120	77	0.206112E	00	120	78	0.247849E	00
120	79	0.293995E	00	120	82	0.219204E	00	120	83	0.261767E	00
120	84	0.308149E	00	120	87	0.228878E	00	120	88	0.275761E	00
120	89	0.324788E	00	120	92	0.237983E	00	120	93	0.293562E	00
120	94	0.344821E	00	120	97	0.258131E	00	120	98	0.318421E	00
120	99	0.368474E	00	120	103	0.350694E	00	120	104	0.394550E	00
120	107	0.357387E	00	120	108	0.384265E	00	120	109	0.419867E	00
120	112	0.396824E	00	120	113	0.409611E	00	120	114	0.438033E	00
120	117	0.413582E	00	120	118	0.417210E	00	120	119	0.454440E	00

BIBLIOGRAPHY

1. Soosaar, K., Grin, R., and Ayer, F., "Analysis and Trade-Off Studies of Large Lightweight Mirror Structures", CSDL Report, April 1975.
2. Maser, K., Soosaar, K., "Structural Analysis of Large Telescope Mirrors and Supports", MIT/CSDL Report No. R-716, (March 1972).
3. Soosaar, K., "Design of Optical Mirror Structures", MIT/CSDL Report No. R-673, (Jan. 1971).