

NASA TECHNICAL NOTE



1. NASA TN D-8033 C.1

NASA TN D-8033

2. u/y

LOAN COPY: RE
AFWL TECHNICAL
KIRTLAND AFB



ORGANOPOLYSILOXANE-BONDED GRAPHITE FLUORIDE AS A SOLID LUBRICANT

Robert L. Fusaro
Lewis Research Center
Cleveland, Ohio 44135





0133858

1. Report No. NASA TN D-8033	2. Government Accession No.	3. Recipient's Catalog No.	
4. Title and Subtitle ORGANOPOLYSILOXANE-BONDED GRAPHITE FLUORIDE AS A SOLID LUBRICANT		5. Report Date July 1975	6. Performing Organization Code
7. Author(s) Robert L. Fusaro	8. Performing Organization Report No. E-8298		10. Work Unit No. 505-04
9. Performing Organization Name and Address Lewis Research Center National Aeronautics and Space Administration Cleveland, Ohio 44135		11. Contract or Grant No.	
12. Sponsoring Agency Name and Address National Aeronautics and Space Administration Washington, D. C. 20546		13. Type of Report and Period Covered Technical Note	
15. Supplementary Notes		14. Sponsoring Agency Code	
16. Abstract A study was conducted on the lubricating properties of organopolysiloxane-bonded graphite fluoride ((CF _{1.1}) _n) films. These studies included the effects of temperature, atmosphere, composition of organopolysiloxane, and burnishing additional (CF _{1.1}) _n powder onto the film surface. For comparison, similar experiments were conducted on organopolysiloxane-bonded MoS ₂ films. In general, the results were equivalent for both films, except that in a moist air environment the wear lives of the films formulated with (CF _{1.1}) _n were up to 10 times longer than the wear lives of the MoS ₂ -formulated films. Comparison to other (CF _{1.1}) _n films showed organopolysiloxane films to give better lubrication results than hand-burnished (CF _{1.1}) _n films but not as good as polyimide-bonded (CF _{1.1}) _n films.			
17. Key Words (Suggested by Author(s)) Solid lubricant; Graphite fluoride; (CF _{1.1}) _n ; Carbon monofluoride; Organopolysiloxane; Glass resin; Bonded film		18. Distribution Statement Unclassified - unlimited STAR Category 27 (rev.)	
19. Security Classif. (of this report) Unclassified	20. Security Classif. (of this page) Unclassified	21. No. of Pages 21	22. Price* \$3.25

ORGANOPOLYSILOXANE-BONDED GRAPHITE FLUORIDE AS A SOLID LUBRICANT

by Robert L. Fusaro

Lewis Research Center

SUMMARY

A solid lubricant film consisting of organopolysiloxane as the binder and graphite fluoride ($(CF_{1.1})_n$) as the lubricant was formulated. A hemisphere-on-flat-disk type of friction apparatus was used to evaluate the friction, rider wear, and wear life of the films, which were bonded to roughened 440C stainless steel disks. The test conditions were a 1-kilogram load, a 2.6-meter-per-second sliding velocity, and 440C stainless steel riders.

For comparison, similar experiments were conducted on organopolysiloxane-bonded molybdenum disulfide (MoS_2) films. In general, wear lives, minimum friction coefficients, and rider wear volumes were equivalent for both films, with the one exception that in a moist air atmosphere the wear lives of the films formulated with $(CF_{1.1})_n$ were up to 10 times longer than the wear lives of films formulated with MoS_2 . The results were also compared with those for burnished $(CF_{1.1})_n$ films and polyimide (PI)-bonded $(CF_{1.1})_n$ films. The organopolysiloxane-bonded $(CF_{1.1})_n$ films gave longer wear lives than did the burnished $(CF_{1.1})_n$ films, but not as long as did the PI-bonded $(CF_{1.1})_n$ films. A possible advantage of organopolysiloxane over polyimide as a binder is that it has a much lower cure temperature.

Three different types of organopolysiloxanes were evaluated as a binder for $(CF_{1.1})_n$. Essentially no difference was found. Rubbing additional $(CF_{1.1})_n$ powder onto a cured organopolysiloxane-bonded $(CF_{1.1})_n$ surface was found to be beneficial in giving longer wear lives and lower rider wear rates.

The effect of test atmosphere on the rider wear, friction coefficient, and wear life of the organopolysiloxane-bonded $(CF_{1.1})_n$ films was also studied. Dry air (20-ppm H_2O), moist air (10 000-ppm H_2O), and dry argon (10 ppm- H_2O) test atmospheres were used. The lowest friction and least rider wear, as well as the longest wear lives were obtained in dry argon. The moist air atmosphere gave longer wear lives than the dry air atmosphere, but the friction coefficient and rider wear rate were higher.

INTRODUCTION

Previous studies on graphite fluoride ($(CF_x)_n$) have shown it to have excellent lubricating properties under various conditions and types of applications. Burnished films of graphite fluoride applied by this researcher gave improved lubrication results when compared to burnished films of molybdenum disulfide (MoS_2) or graphite (refs. 1 and 2). Further improvement has been obtained by this researcher when graphite fluoride powder was bonded to the surface using a polyimide binder (refs. 3 and 4). Improved lubrication results have also been reported by Ishikawa (refs. 5 and 6) with graphite fluoride added to greases, mechanical carbons, and carbon-fiber-reinforced polytetrafluoroethylene (PTFE). Graphite fluoride has also been combined with silicate or epoxy-phenolic binders with good results by Gisser (ref. 7). Another promising technique for applying graphite fluoride was reported by Tsuya (ref. 8). The method consisted of depositing graphite fluoride and a metal simultaneously by use of an electroplating bath.

Solid lubricants usually give longer wear lives when they are used in conjunction with a binder rather than simply burnishing them onto a surface. The polyimide binder used in references 3 and 4 gave exceptionally good results. It had one undesirable feature, however. In order to polymerize it, the film had to be baked at the relatively high temperature of $300^\circ C$. For some potential applications of solid lubricants, such a high cure temperature may be undesirable. For this reason and also in the hope of finding an even better binder material for graphite fluoride, a series of experiments were conducted using an organopolysiloxane polymer as a binder for graphite fluoride. This polymer was chosen because other researchers (ref. 9) have obtained good lubrication results with it as a binder for molybdenum disulfide (MoS_2), and because it has a relatively low cure temperature of 90° to $135^\circ C$.

In this study, films were formulated with organopolysiloxane and $(CF_{1.1})_n$, similar to the ones previously formulated with polyimide and $(CF_{1.1})_n$, and their friction coefficients, wear lives, and rider wear volumes were compared. Similar films were also formulated with organopolysiloxane and MoS_2 and the results compared. Other areas that were investigated were the effects of temperature, atmosphere, organopolysiloxane composition, and rubbing additional $(CF_{1.1})_n$ powder onto the bonded film surface.

MATERIALS

The organopolysiloxane used in this investigation was a condensation polymer based on an alternating silicon-oxygen system; thus, in general, it can be classified in the silicone family (refs. 10 and 11). Unlike conventional silicones, however, it can be cured to a crystal-clear thermosetting material. For this reason these polymers have

been referred to as "glass resins." Table I lists some of the general properties of organopolysiloxanes.

As with many polymers, it is possible to tailor different properties into the organopolysiloxanes by varying the type and relative amounts of the starting materials (refs. 10 and 11). In this investigation, three different organopolysiloxane compositions were studied. The first contained approximately 60 percent silicon and oxygen, the second contained approximately 50 percent silicon and oxygen, and the third contained approximately 80 percent silicon and oxygen.

FRICITION APPARATUS

The apparatus used to evaluate the lubricating properties of organopolysiloxane-bonded solid lubricants is illustrated in figure 1. Basically, the device consists of a flat disk (6.3-cm diam) in sliding contact with a stationary hemispherically tipped rider (0.476-cm rad.). A 1-kilogram deadweight load is applied to the rider as the disk rotates at 1000 rpm. The rider creates a 5-centimeter-diameter wear track on the rotating disk, giving it linear sliding velocity of 2.6 meters per second.

Induction heating was used to heat the disk. The temperature was monitored by an infrared pyrometer focused on the wear track of the disk. A strain gage was used to sense the frictional force, which was continuously recorded on a strip-chart recorder.

PROCEDURE

Surface Preparation and Cleaning Procedure

The hardness range of the 440C stainless steel specimens used in this investigation was Rockwell C 58 to 60. The disk surfaces were roughened by sandblasting to a rms value of 0.9 to 1.3 micrometers (35×10^{-6} to 50×10^{-6} in.). The cleaning procedure after the disks were sandblasted was as follows:

- (1) Scrub surface under running water with a brush to remove abrasive particles.
- (2) Clean surface with pure ethyl alcohol.
- (3) Scrub surface with a water paste of levigated alumina. Clean until water wets the surface readily.
- (4) Rinse under running water to remove levigated alumina (using brush to facilitate removal).
- (5) Rinse in distilled water.
- (6) Dry surfaces using dry compressed air. (Surfaces not dried quickly have a tendency to oxidize.)

The riders were also cleaned by this procedure; but since the riders were not sandblasted, step 1 was not included.

Coating Formulation

The organopolysiloxane-bonded MoS_2 films were prepared by mixing three parts (by weight) of MoS_2 powder with one part (by weight) of organopolysiloxane solids. The organopolysiloxane-bonded $(\text{CF}_{1.1})_n$ films were prepared by mixing three parts (by weight) of $(\text{CF}_{1.1})_n$ powder with two parts (by weight) of organopolysiloxane solids. The density of $(\text{CF}_{1.1})_n$ was approximately one-half that of MoS_2 ; therefore, the two film formulations contained nearly equal volume percents of solid lubricants. Pure ethanol was used as a solvent for the organopolysiloxane. Enough was added to each formulation to obtain a sprayable solution.

Film Application

The liquid mixture of organopolysiloxane and solid lubricant was sprayed onto each disk with an artist's airbrush. When the desired thickness of 10 to 20 micrometers was obtained, the curing procedure was carried out. This procedure consisted of baking the film at 90°C for 1/2 hour and then at 135°C for 4 hours.

After cooling, some of the film surfaces were enriched with their respective solid lubricants. Two methods of applying the solid lubricant powder were employed. The first was to burnish $(\text{CF}_{1.1})_n$ or MoS_2 ($\sim 1/4$ g) onto the film surface with a napped cloth. The cloth was wrapped around the index finger, and considerable pressure was applied. Burnishing continued until the surface appeared glossy.

The second method of enriching the surface was to burnish the $(\text{CF}_{1.1})_n$ powder into the film surface by using the line contact region of a double hemispherically tipped metal cylinder (1-cm diam; 2-cm length). The $(\text{CF}_{1.1})_n$ was applied to the surface and evenly distributed with the napped cloth before the surface was burnished with the metal cylinder. Short back-and-forth strokes with the cylinder were used. As burnishing continued, greater pressure was applied to the metal cylinder. Using the cylinder tended to smooth the surfaces of the films and also reduced their apparent thickness somewhat.

Test Procedure

The procedure for conducting these experiments was as follows: a rider and a disk (with applied solid lubricant film) were inserted into the friction apparatus (fig. 1). The

test chamber was sealed, and dry air (20-ppm H₂O), moist air (10 000-ppm H₂O), or dry argon (10-ppm H₂O) was purged through the chamber for 15 minutes. The flow rate was 1500 cubic centimeters per minute. This flow rate maintained a slight positive pressure in the chamber, which had a volume of 2000 cubic centimeters.

When the purge was completed, the temperature of the disk was slowly raised to the desired temperature by induction heating. The disk was set into rotation at 1000 rpm, and the temperature was held for 10 minutes to allow it to stabilize. A 1-kilogram load was then applied as the disk rotated.

Some preliminary experiments were conducted to determine the friction characteristics of unlubricated 440C stainless steel. From these results, it was decided to make the criterion for failure a friction coefficient of 0.30 since this value was less than the friction coefficient of unlubricated 440C stainless steel over the whole experimental temperature range. An automatic cutoff system was used to shut down the apparatus when the friction coefficient reached 0.30. In order to determine rider wear before failure, the tests were stopped after 1 hour of sliding (60 kilocycles). The wear scar diameter on the hemispherically tipped rider was measured and wear volume calculated. For comparison, the wear rate and friction coefficient for unlubricated 440C stainless steel were also determined. A similar procedure was followed except that no cutoff friction coefficient was used.

RESULTS AND DISCUSSION

Effect of Organopolysiloxane Type

Three different types of organopolysiloxanes were available for evaluation. They contained, respectively, 50, 60, and 80 percent silicon and oxygen. To determine which would be the best binder for graphite fluoride, a series of friction, rider wear, and film wear life experiments were conducted on films formulated with each organopolysiloxane type. Each film was formulated from 40-wt % organopolysiloxane solids and 60-wt % (CF_{1.1})_n solids. This lubricant/binder ratio was chosen since good results were achieved when it was used with polyimide-bonded (CF_{1.1})_n (refs. 3 and 4). The test conditions were a load of 1 kilogram, a sliding velocity of 2.6 meters per second (1000 rpm), a dry air atmosphere (20-ppm H₂O), a test temperature of 25^o C, and 440C stainless steel riders and disks.

The results of these experiments are plotted in figure 2, where wear life, friction coefficient, and rider wear volume are given for each different type of organopolysiloxane-bonded (CF_{1.1})_n film. At least five tests were performed on each composition; and the figure gives maximum, minimum, and average values for each.

The main conclusion of these experiments was that essentially there was no advantage to using any one particular type of organopolysiloxane as a binder for the solid lubricant graphite fluoride $(CF_{1.1})_n$. The average wear lives for the organopolysiloxane-bonded $(CF_{1.1})_n$ films containing 60, 50, and 80 percent silicon and oxygen were, respectively, 415, 420, and 340 kilocycles. The maximum values of wear life were, respectively, 580, 530 and 510 kilocycles; and the minimum values were, respectively, 310, 310, and 210 kilocycles. The average minimum friction coefficients obtained on the 60, 50, and 80 percent compositions were, respectively, 0.05, 0.06, and 0.04. The average rider wear volumes after 60 000 cycles of sliding on the 60, 50, and 80 percent compositions were, respectively, 0.29×10^{-12} , 0.46×10^{-12} , and 0.31×10^{-12} cubic meter. The maximum and minimum, as well as the average, values are given in figure 2.

The average wear life results appear to indicate that the organopolysiloxane-bonded $(CF_{1.1})_n$ films containing 60 and 50 percent silicon and oxygen are somewhat better lubricant films than the one containing 80 percent silicon and oxygen. However, when all the results are considered, the 80 percent composition appears to be equivalent to the other two. The main difference between it and the other two was that the minimum wear life was shorter. One bad test may mean only that the film was improperly applied.

Since all three types of organopolysiloxane-bonded $(CF_{1.1})_n$ films gave approximately equivalent results, the remainder of this study was conducted using only the composition which contained 60 percent silicon and oxygen. Thus, from this point, when organopolysiloxane is referred to, it will mean the 60 percent composition.

Effect of Enriching Film Surface with $(CF_{1.1})_n$ Powder

A series of experiments were conducted to determine if there were any advantages to enriching the surface of organopolysiloxane-bonded $(CF_{1.1})_n$ with additional $(CF_{1.1})_n$ powder and to determine if application technique was important. For details on the application technique, see the section Film Application.

Figure 3 illustrates the effect of surface enrichment and application technique on the surface condition of organopolysiloxane-bonded $(CF_{1.1})_n$. Shown in the figure are the schematic cross sections of the nonenriched film, the cloth-burnished film, and the metal-burnished film. (These cross sections are based on surface profiles of the roughened 440C stainless steel before film application and the film surface after application.) Cloth burnishing did not have a noticeable effect on the surface condition. The surface profiles of the nonenriched and the cloth-burnished films look very much alike. Apparently, the $(CF_{1.1})_n$ powder adhered uniformly to the surface and did not tend to fill up the valleys. Also the amount of $(CF_{1.1})_n$ that was applied was relatively small and may have not completely filled up the valleys. Metal burnishing had a much more

noticeable effect. As figure 3(c) shows, metal burnishing tended to reduce the surface roughness of the film by removing the peaks and filling in the valleys.

The effect of surface enrichment and application technique on the lubricating properties of organopolysiloxane-bonded $(CF_{1.1})_n$ films is shown in figure 4. At least five tests were performed on each surface type; and the figure depicts maximum, minimum, and average values for each surface type. Surface enrichment did not markedly affect the average value of the minimum friction coefficient, which was 0.045 to 0.050. However, the nonenriched films did have more variance (from minimum to maximum friction values) than did the enriched films. Surface enrichment was very beneficial to wear life and rider wear. Average wear lives were increased 60 to 70 percent; and average rider wear, for riders which slid 60 kilocycles, was reduced about three times when enriched films were employed. No discernible difference was found between cloth burnishing and metal burnishing. The main effect of metal burnishing was to remove the high peaks on the film surface and give a more realistic value to the film thickness.

Effect of Atmosphere

The effect of test atmosphere on wear life, minimum friction coefficient, and rider wear of organopolysiloxane-bonded $(CF_{1.1})_n$ films is shown in figure 5. These tests were conducted at 25° C; under a load of 1 kilogram; at a sliding velocity of 2.6 meters per second; and in atmospheres of dry air (20-ppm H₂O), moist air (10 000-ppm H₂O), or dry argon (10-ppm H₂O).

Of the three atmospheres tested, the best results were achieved in a dry argon atmosphere. The minimum friction coefficient obtained was 0.04. Because of the long duration of this test, it was stopped after 5500 kilocycles of sliding although the friction coefficient was still less than 0.10. The rider wear volume (after 60 kilocycles of sliding) in argon was about two-thirds the value obtained for tests run in dry air, and about one-fifth that obtained for tests run in moist air.

The minimum friction coefficient obtained in dry air was slightly higher than that obtained in dry argon, 0.05 compared to 0.04; the value obtained in moist air was the highest, 0.09. Even though rider wear and friction coefficient were less in dry air, wear lives (defined as the number of cycles to reach a friction coefficient of 0.30) were about five times longer in moist air than in dry air. In summary, the data indicate that both water vapor and air were deleterious to organopolysiloxane-bonded $(CF_{1.1})_n$ films. Water vapor was beneficial in providing longer wear lives in air (50 percent relative humidity; 10 000-ppm H₂O) but rider wear rate and friction coefficient were increased when H₂O was present. The reasons for these phenomena should be the subject of future study.

Comparison to Similar Molybdenum Disulfide Films

A series of experiments were conducted on films in which the solid lubricant molybdenum disulfide (MoS_2) was substituted for $(\text{CF}_{1.1})_n$. Since the density of $(\text{CF}_{1.1})_n$ is only about one-half that of MoS_2 , the organopolysiloxane-bonded MoS_2 films were formulated from three parts (by weight) of MoS_2 powder to one part (by weight) of organopolysiloxane solids. The two film formulations, therefore, contained equal volume percents of solid lubricant.

Figure 6 presents results from those tests, along with similar data for the organopolysiloxane-bonded $(\text{CF}_{1.1})_n$ films. Each film formulation was tested at 25°C ; under a load of 1 kilogram; at a sliding velocity of 2.6 meters per second; and in atmospheres of dry air (20-ppm H_2O), moist air (10 000-ppm H_2O), and dry argon (10-ppm H_2O).

The wear life of organopolysiloxane-bonded $(\text{CF}_{1.1})_n$ was equivalent to that of organopolysiloxane-bonded MoS_2 in all test atmospheres. The only major difference was in moist air where the wear life of organopolysiloxane-bonded $(\text{CF}_{1.1})_n$ was 10 times greater than that of organopolysiloxane-bonded MoS_2 . In dry air this difference in wear life was about 2. In dry argon neither film failed before completing the arbitrary test duration of 5500 kilocycles.

The friction coefficients for organopolysiloxane-bonded MoS_2 were slightly less than those of organopolysiloxane-bonded $(\text{CF}_{1.1})_n$, although the differences were not great. The friction coefficients for organopolysiloxane-bonded MoS_2 in atmospheres of dry air, moist air, and dry argon were, respectively, 0.03, 0.07, and 0.02. Similar friction coefficients for organopolysiloxane-bonded $(\text{CF}_{1.1})_n$ were, respectively, 0.05, 0.09, and 0.04.

For each respective test atmosphere, the rider wear volumes (after 60 kilocycles of sliding) for the two films were nearly equivalent. Thus, the main advantage of organopolysiloxane-bonded $(\text{CF}_{1.1})_n$ over organopolysiloxane-bonded MoS_2 was that longer wear lives were obtained with the $(\text{CF}_{1.1})_n$ formulation in a normal room-air environment (represented by the moist air test environment (50-percent relative humidity; 10 000-ppm H_2O)).

Effect of Temperature and Comparison to Other Graphite Fluoride $((\text{CF}_{1.1})_n)$ Films

A series of experiments were conducted on organopolysiloxane-bonded $(\text{CF}_{1.1})_n$ films to determine the effect of temperature on the wear life properties of these films and also to see how they compared to other $(\text{CF}_{1.1})_n$ films which were tested under similar conditions (ref. 3). The test conditions were a dry air atmosphere (20-ppm H_2O), a load of 1 kilogram, a sliding velocity of 2.6 meters per second, 440C stainless

steel riders and disks, and a failure criterion which entailed the friction coefficient reaching a value of 0.30. The results of these experiments are shown in figure 7.

The wear life of organopolysiloxane-bonded $(CF_{1.1})_n$ decreased with temperature, as did that of the burnished $(CF_{1.1})_n$ film. However, the wear life of organopolysiloxane-bonded $(CF_{1.1})_n$ was somewhat better than that of burnished $(CF_{1.1})_n$ films, at least to $400^{\circ}C$. At ambient temperature, $25^{\circ}C$, it was from two to three times longer; but as temperature was increased the difference became less, until at $400^{\circ}C$ the wear lives were essentially the same.

While in most instances organopolysiloxane-bonded $(CF_{1.1})_n$ films gave longer wear lives than did burnished $(CF_{1.1})_n$ films, they did not give nearly as long a wear life as did PI-bonded $(CF_{1.1})_n$ films. The difference in wear life depended somewhat on test temperature, but in general PI-bonded $(CF_{1.1})_n$ films gave from 5 to 10 times longer wear lives than did organopolysiloxane-bonded $(CF_{1.1})_n$ films.

The minimum friction coefficients as a function of temperature for the three films are compared in figure 8. Also shown is the friction coefficient of unlubricated 440C stainless steel sliding on itself (ref. 3). As seen in the figure, the friction coefficient for each film remained relatively constant in the temperature range 25° to $400^{\circ}C$. The organopolysiloxane-bonded $(CF_{1.1})_n$ film and the burnished $(CF_{1.1})_n$ film gave minimum friction coefficients which were essentially the same, ranging between 0.04 and 0.05. The friction coefficient of the PI-bonded $(CF_{1.1})_n$ film was slightly higher than this range, having a value of 0.08.

Comparison of the wear which occurred to 440C riders after they had slid for 1 hour (60 kilocycles) against the three $(CF_{1.1})_n$ films is shown in figure 9. Test conditions were a load of 1 kilogram, a sliding velocity of 2.6 meters per second, a dry air atmosphere (20-ppm H_2O), and a test temperature of $25^{\circ}C$. Also shown in the figure are rider wear data obtained from three similarly formulated films in which MoS_2 was the solid lubricant instead of $(CF_{1.1})_n$. All films were formulated with the same volume percent of solid lubricant in the composition. For comparison, the wear of the base metal, 440C stainless steel, which was run in the unlubricated condition (ref. 3), is also shown.

Rider wear tended to depend more upon the type of film on which the rider slid than upon whether MoS_2 or $(CF_{1.1})_n$ was used in the film. The best results were obtained with the PI-bonded solid lubricant films. The rider wear rate for riders sliding on burnished solid lubricants was about 10 times greater than the rider wear rate with the PI-bonded films. The organopolysiloxane-bonded films gave wear results that fell about halfway between the results for the PI-bonded films and the burnished films. Rider wear on unlubricated 440C stainless steel was 5000 times greater than rider wear on the organopolysiloxane-bonded solid lubricant films.

SUMMARY OF RESULTS

Friction and wear experiments conducted on organopolysiloxane-bonded graphite fluoride ($(CF_{1.1})_n$) films gave the following results:

1. Essentially no difference in lubricating properties was found when three different organopolysiloxane polymers were used as binders for $(CF_{1.1})_n$.

2. Enriching the surface with additional $(CF_{1.1})_n$ powder increased wear life 50 percent and decreased rider wear about three times.

3. Organopolysiloxane-bonded $(CF_{1.1})_n$ films provided better lubrication results than did hand-burnished films of $(CF_{1.1})_n$. However, when compared to polyimide-bonded $(CF_{1.1})_n$ films, the results were not nearly as good.

4. Test atmosphere was very influential in determining wear life, friction coefficient, and rider wear. In each of the preceding, the best results were obtained in a dry argon atmosphere (10-ppm H_2O). Longer wear lives were obtained in moist air (10 000-ppm H_2O) than in dry air (20-ppm H_2O). However, minimum friction coefficient and rider wear were higher in moist air than in dry air.

5. The main advantage of using $(CF_{1.1})_n$ instead of molybdenum disulfide (MoS_2) as the solid lubricant in the organopolysiloxane binder was that longer wear lives were obtained in a normal room-air environment (represented by the 50-percent relative humidity (moist air) test environment). Otherwise, equivalent results were obtained.

Lewis Research Center,
National Aeronautics and Space Administration,
Cleveland, Ohio, April 11, 1975,
505-04.

REFERENCES

1. Fusaro, Robert L.; and Sliney, Harold E.: Preliminary Investigation of Graphite Fluoride $(CF_x)_n$ as a Solid Lubricant. NASA TN D-5097, 1969.
2. Fusaro, Robert L.; and Sliney, Harold E.: Graphite Fluoride $(CF_x)_n$ - A New Solid Lubricant. ASLE Trans., vol. 13, no. 1, Jan. 1970, pp. 56-65.
3. Fusaro, Robert L.; and Sliney, Harold E.: Graphite Fluoride as a Solid Lubricant in a Polyimide Binder. NASA TN D-6714, 1972.
4. Fusaro, Robert L.; and Sliney, Harold E.: Lubricating Characteristics of Polyimide Bonded Graphite Fluoride and Polyimide Thin Films. ASLE Trans., vol. 16, no. 3, July 1973, pp. 189-196.

5. Ishikawa, T.; and Shimada, T.: Application of Polycarbon Monofluoride. Presented at Fluorine Symposium, Moscow, 1969.
6. Ishikawa, T.; Teranishi, H.; and Morishita, M.: Carbon Fiber, and Composite Materials of Carbon Fiber and Polytetrafluorethylene. Presented at International Conference on Carbon Fibers, Their Composites and Applications, London, England, Feb. 2-4, 1971.
7. Gisser, H.; Petronio, M.; and Shapiro, A.: Graphite Fluoride as a Solid Lubricant. Lub. Eng., vol. 28, no. 5, May 1972, pp. 161-164.
8. Tsuya, Y.; Eumura, H.; Okamoto, Y.; and Kurosaki, S.: Codeposited Composite Metal-Graphite Fluoride Platings - Lubrication Properties. ASLE Preprint 73LC-4B-2, Oct. 1973.
9. Campbell, Mahlon E.; and Hass, Hugh: Research on Bearing Lubrication for Use in a High Vacuum. (Midwest Research Inst.; NAS8-21165), NASA CR-103003, 1970.
10. Burzynski, A. J.; and Johnson, C. A.: Process of Coating Plastics with Organo Polysiloxanes and Articles Made Thereby. U. S. Patent 3,451,838, June 24, 1969.
11. Burzynski, A. J.: Process for the Application of a Further Curable Organopolysiloxane to Metal. U.S. Patent 3,460,980, Aug. 12, 1969.

TABLE I. - TYPICAL PROPERTIES OF ORGANOPOLYSILOXANES

Physical properties:	
Specific gravity	1.3
Tensile strength, N/m ²	2.4×10 ⁷
Flexural strength, N/m ²	3.4×10 ⁷
Compressive strength, N/m ²	2.1×10 ⁸
Impact strength (Izod), J/m of notch	1.6
Flammability	Nonflammable
Transparent to light of wavelength, nm	200 - 700
Hardness of 0.635-cm-thick sample, Rockwell (R scale)	120 - 140
Thermal properties:	
Coefficient of linear expansion (0° to 300° C), m/m/°C	13×10 ⁻⁵
Thermal conductivity, J/cm ² /sec/°C/cm	1.4×10 ⁻³
Thermal stability in vacuum, °C	450
Chemical properties:	
Chemically resistant to acids and bases	
Cured polymer insoluble in organic solvents	

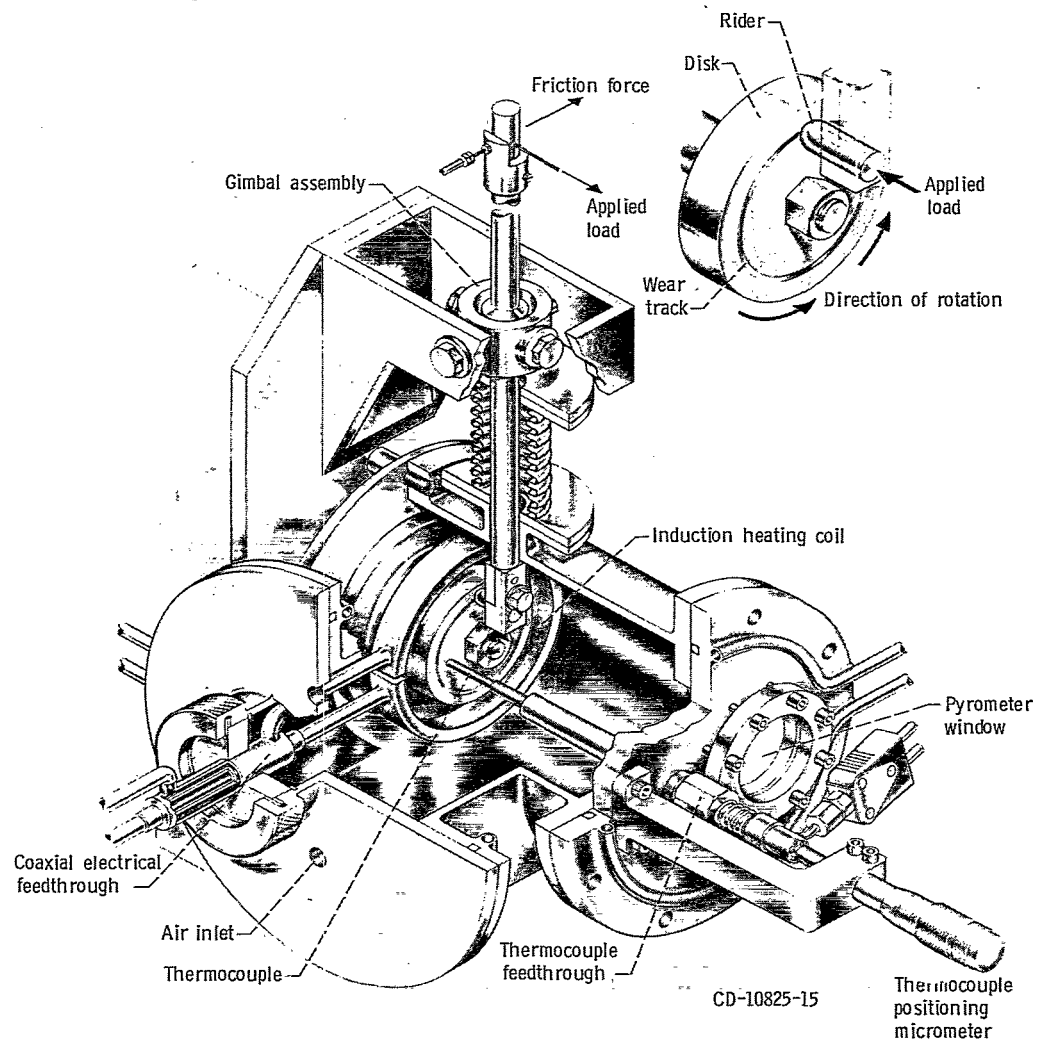
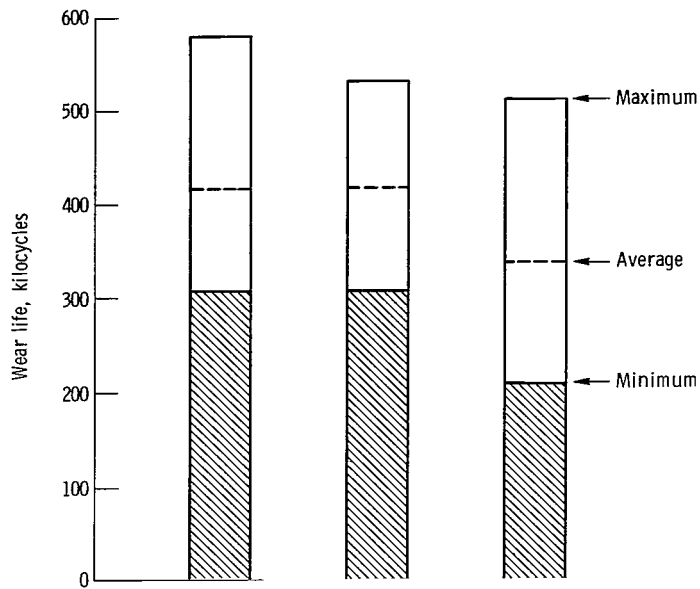
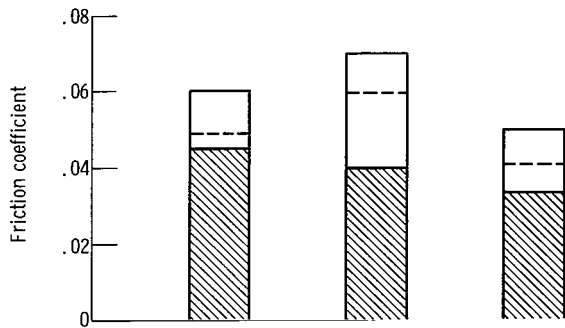

Figure 1. - Friction and wear testing device.



(a) Wear life.



(b) Minimum friction coefficient.

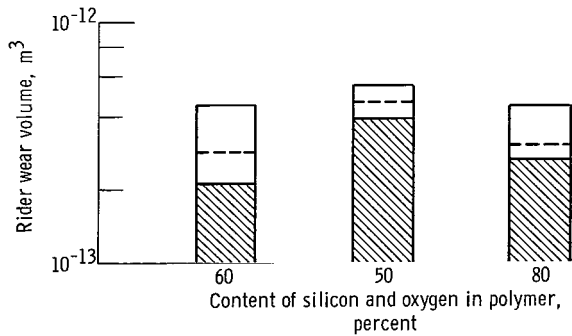

(c) Rider wear after 60 kilocycles of sliding.

Figure 2. - Comparison of three types of organopolysiloxanes, containing different amounts of silicon and oxygen, as binders for graphite fluoride ($(CF_{1.1})_n$). Test temperature, 25° ; load, 1 kilogram; sliding velocity, 2.6 meters per second; riders and disks, 440C stainless steel; test atmosphere, dry air (20-ppm H_2O); failure criterion, friction coefficient of 0.30. (Surfaces were enriched by burnishing additional $(CF_{1.1})_n$ powder onto the film surface; at least five tests were performed on each composition.)

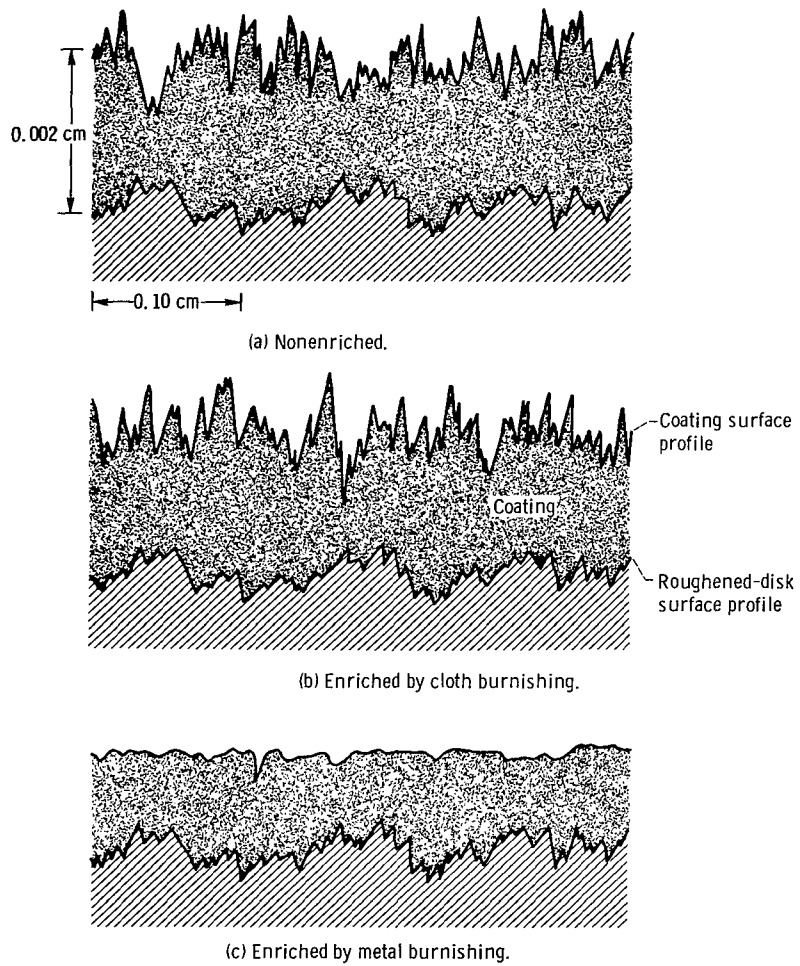

Figure 3. - Effect of surface enrichment and application technique on surface condition of organopolysiloxane-bonded $(CF_{1.1})_n$. Surface enriched with powdered $(CF_{1.1})_n$.

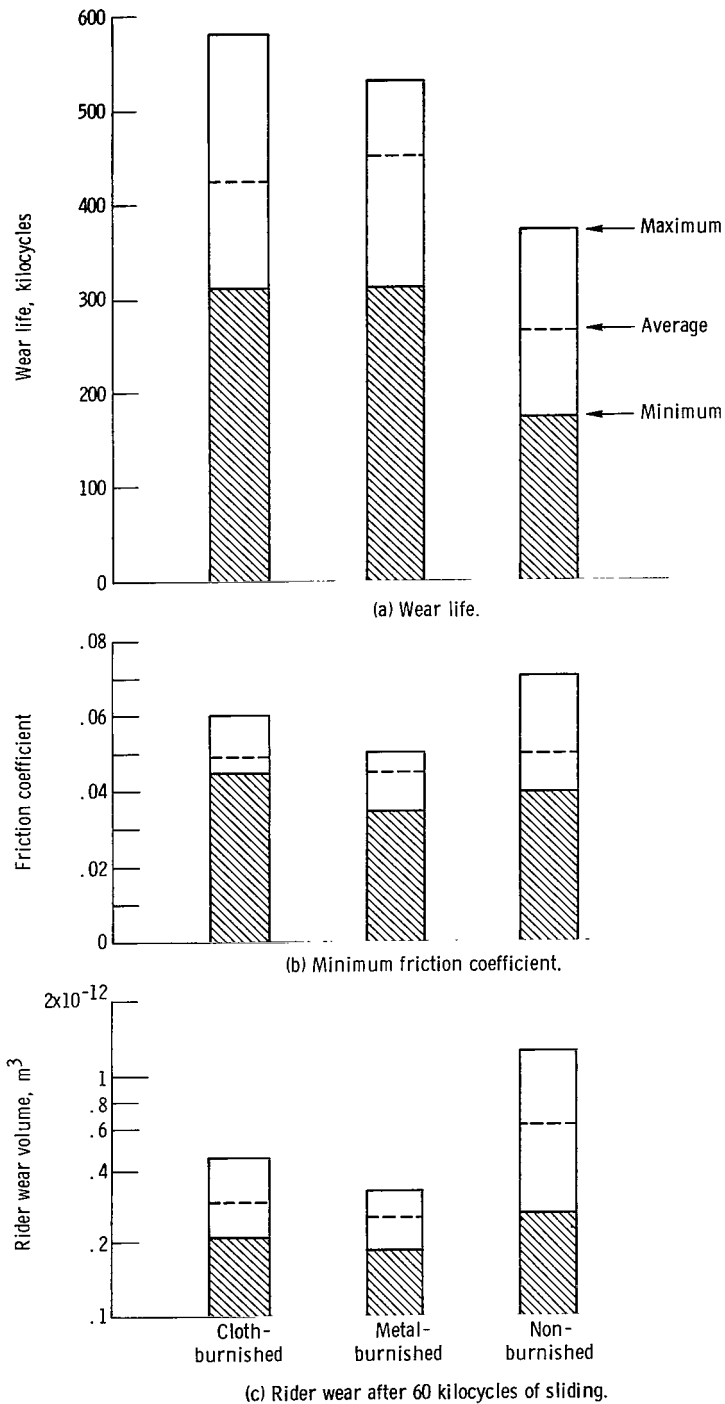

Figure 4. - Effect of surface enrichment and application technique on lubricating properties of organopolysiloxane-bonded $(CF_2)_n$. Test temperature, 25°C; load, 1 kilogram; sliding velocity, 2.6 meters per second; riders and disks, 440C stainless steel; test atmosphere, dry air (20-ppm H_2O). (Surfaces were enriched by burnishing additional $(CF_2)_n$ powder onto the film surface by using either a cloth or a double hemispherically tipped metal cylinder; at least five tests were performed on each surface condition.)

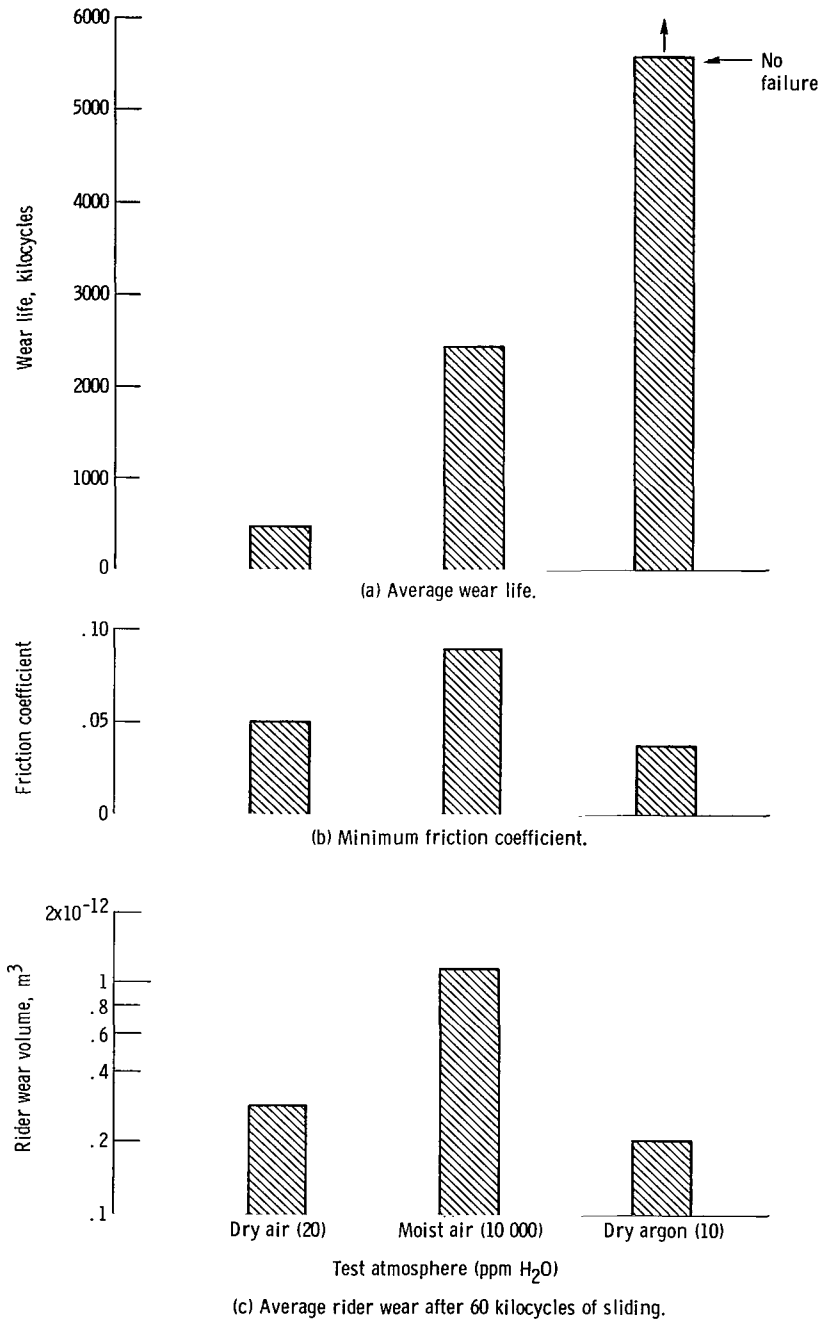

Figure 5. - Effect of atmosphere on lubricating properties of organopolysiloxane-bonded $(CF_3)_2SiH$. Test temperature, 25^o C; load, 1 kilogram; sliding velocity, 2.6 meters per second; riders and disks, 440C stainless steel.

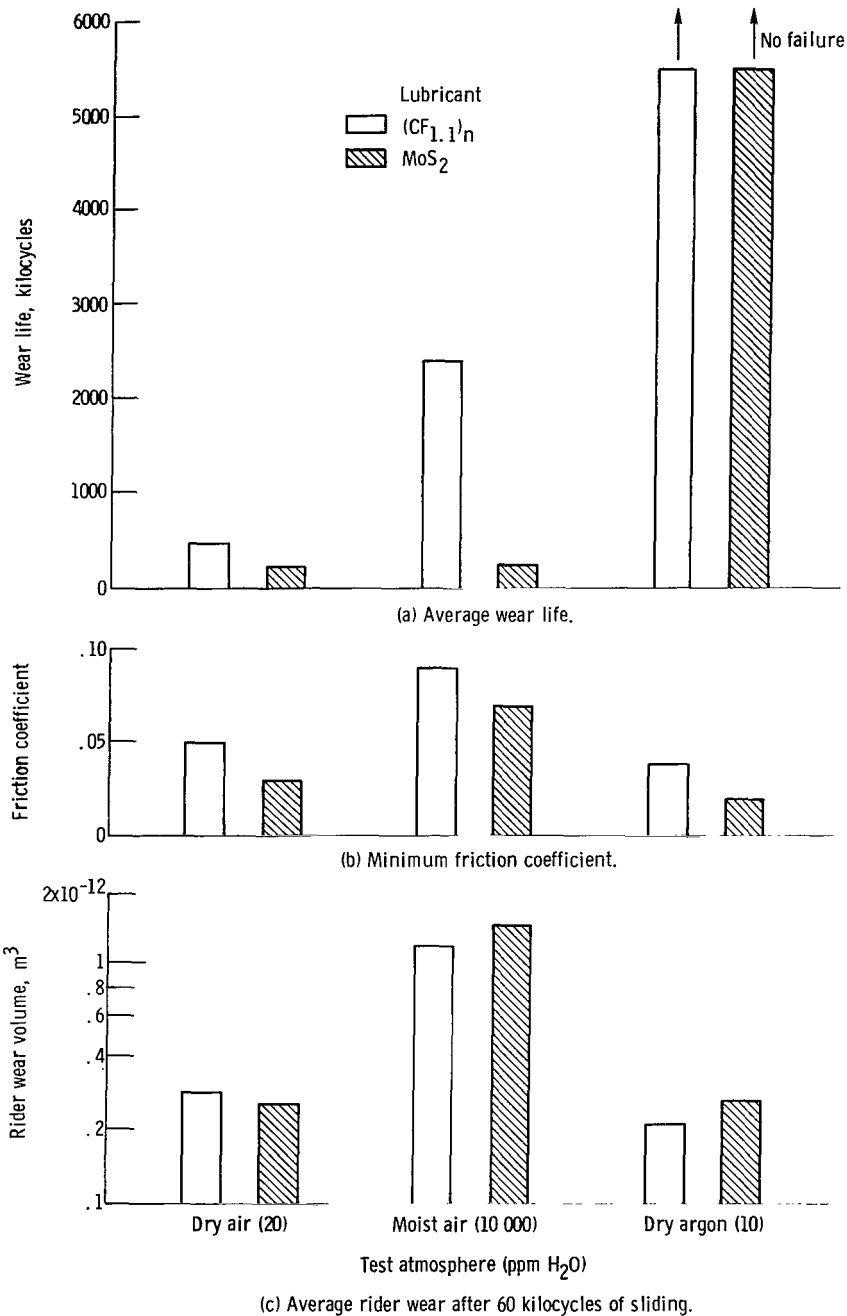

Figure 6. - Comparison of lubrication properties of organopolysiloxane-bonded $(CF_{1.1})_n$ films and organopolysiloxane-bonded MoS_2 films which were tested in three different atmospheres. Test temperature, $25^{\circ}C$; load, 1 kilogram; sliding velocity, 2.6 meters per second; riders and disks, 440C stainless steel.

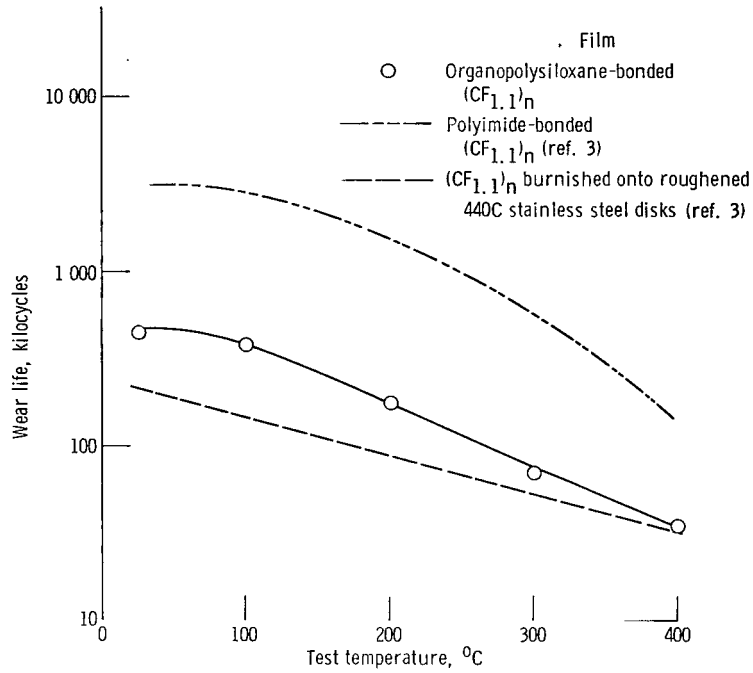

Figure 7. - Effect of temperature on wear life of three different (CF_{1.1})_n films. Load, 1 kilogram; sliding velocity, 2.6 meters per second; riders and disks, 440C stainless steel; test atmosphere, dry air (20-ppm H₂O); failure criterion, friction coefficient of 0.30.

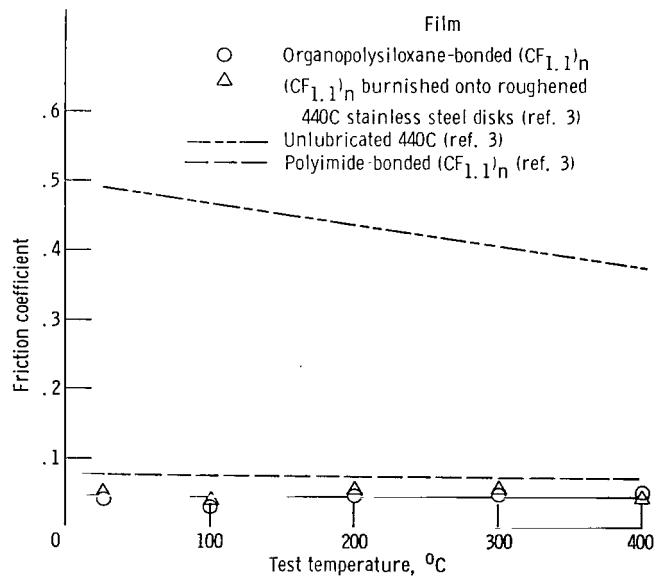

Figure 8. - Effect of temperature on minimum friction coefficient of three different (CF_{1.1})_n films. Load, 1 kilogram; sliding velocity, 2.6 meters per second; riders and disks, 440C stainless steel; test atmosphere, dry air (20-ppm H₂O).

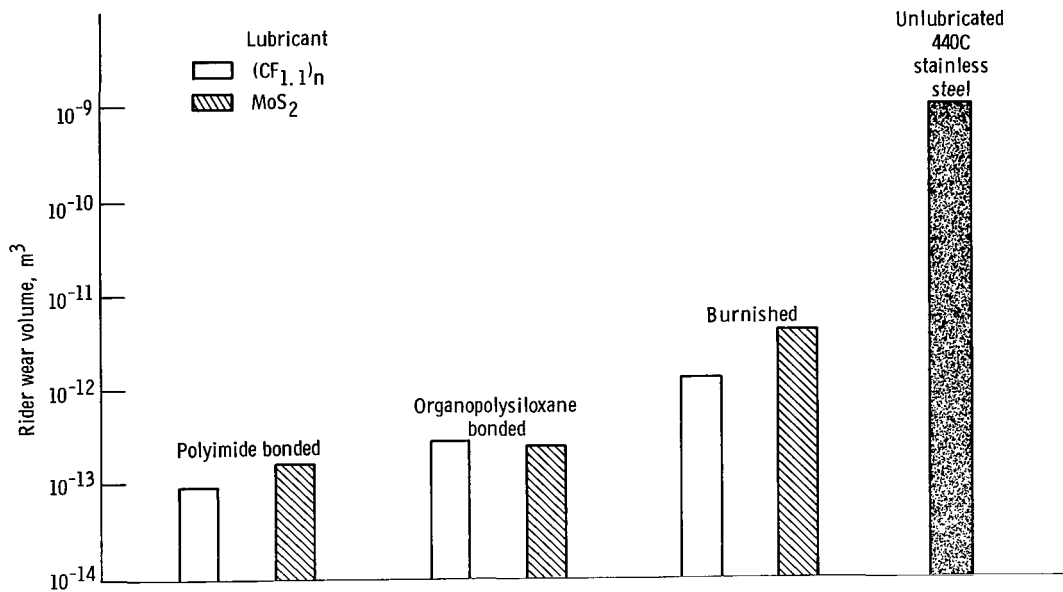

Figure 9. - Comparison of wear occurring to 440C stainless steel riders after sliding for 60 kilocycles against 440C stainless steel disks coated with six different solid lubricant films. Test temperature, 25^o C; load, 1 kilogram; sliding velocity, 2.6 meters per second; test atmosphere, dry air (20-ppm H₂O). (Data included from ref. 3.)

NATIONAL AERONAUTICS AND SPACE ADMINISTRATION
WASHINGTON, D.C. 20546

OFFICIAL BUSINESS
PENALTY FOR PRIVATE USE \$300

SPECIAL FOURTH-CLASS RATE
BOOK

POSTAGE AND FEES PAID
NATIONAL AERONAUTICS AND
SPACE ADMINISTRATION
451



741 001 C1 U C 750711 S00903DS
DEPT OF THE AIR FORCE
AF WEAPONS LABORATORY
ATTN: TECHNICAL LIBRARY (SUL)
KIRTLAND AFB NM 87117

POSTMASTER: If Undeliverable (Section 158
Postal Manual) Do Not Return

"The aeronautical and space activities of the United States shall be conducted so as to contribute . . . to the expansion of human knowledge of phenomena in the atmosphere and space. The Administration shall provide for the widest practicable and appropriate dissemination of information concerning its activities and the results thereof."

—NATIONAL AERONAUTICS AND SPACE ACT OF 1958

NASA SCIENTIFIC AND TECHNICAL PUBLICATIONS

TECHNICAL REPORTS: Scientific and technical information considered important, complete, and a lasting contribution to existing knowledge.

TECHNICAL NOTES: Information less broad in scope but nevertheless of importance as a contribution to existing knowledge.

TECHNICAL MEMORANDUMS: Information receiving limited distribution because of preliminary data, security classification, or other reasons. Also includes conference proceedings with either limited or unlimited distribution.

CONTRACTOR REPORTS: Scientific and technical information generated under a NASA contract or grant and considered an important contribution to existing knowledge.

TECHNICAL TRANSLATIONS: Information published in a foreign language considered to merit NASA distribution in English.

SPECIAL PUBLICATIONS: Information derived from or of value to NASA activities. Publications include final reports of major projects, monographs, data compilations, handbooks, sourcebooks, and special bibliographies.

TECHNOLOGY UTILIZATION PUBLICATIONS: Information on technology used by NASA that may be of particular interest in commercial and other non-aerospace applications. Publications include Tech Briefs, Technology Utilization Reports and Technology Surveys.

Details on the availability of these publications may be obtained from:

SCIENTIFIC AND TECHNICAL INFORMATION OFFICE

NATIONAL AERONAUTICS AND SPACE ADMINISTRATION

Washington, D.C. 20546