

PERMANENT AND SEPARABLE AEROSPACE TUBING/FITTING EVALUATION PROGRAM

VOLUME I
FINAL REPORT

SwRI Projects 03-3113 and 03-3996

N75-27394

Unclas
29247

G3/37

(NASA-CR-141899) PERMANENT AND SEPARABLE
AEROSPACE TUBING/ FITTING EVALUATION
PROGRAM, VOLUME I Final Report (Southwest
Research Inst.) 103 p HC \$5.25 CACL 13E

Prepared for

NASA Johnson Space Center
Test Engineering Branch
W. K. Andrews WT-2
Houston, Texas 77058
NASA Contract NAS-9-14265

and

Air Force Systems Command
Aeronautical Systems Division, ASD/FNJPH
Wright-Patterson Air Force Base Base, Ohio 45433
AF Contract F33657-71-C-0914

Prepared by
C. R. Ursell and C. R. Franz

May 1975



"Approved for public release; distribution unlimited"

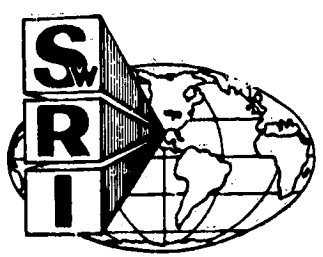

SOUTHWEST RESEARCH INSTITUTE
SAN ANTONIO CORPUS CHRISTI HOUSTON

ACKNOWLEDGEMENTS

The fitting/tubing evaluation program was sponsored by the Air Force Systems Command, Aeronautical Systems Division, Wright-Patterson Air Force Base, Ohio, under Contract No. F33657-71-C-0914. Program technical direction, coordination and monitoring was provided by Messrs. Sorro Prete, Robert E. Reitz, Raymond R. Hess and Jesse A. Poole, III. The assistance of this team is gratefully acknowledged as they directed their efforts towards obtaining the maximum results from the products presented by industry.

The assistance of SAE Committees and various industry personnel is gratefully acknowledged since these contributions aided the advancement of the state-of-the-art. The engineering departments of participating organizations supported the program in the areas of their particular product designs.

Following cancellation of the program by USAF, NASA funded the remaining testing in order to have available the complete data package for verification of fitting selections on future projects. No changes were made in this Volume I report as all tests conducted for NASA were identical to those conducted for USAF in order to maintain continuity and correlatability of data.

TABLE OF CONTENTS

	<u>Page</u>
LIST OF ILLUSTRATIONS	iv
LIST OF TABLES	v
I. INTRODUCTION	1
II. PROGRAM BACKGROUND AND REQUIREMENTS	3
III. DATA REVIEW	7
IV. TEST PROGRAM	10
V. SURVEY OF INDUSTRY	19
VI. TEST PROCEDURES	22
TEST PROCEDURES AND EQUIPMENT (see page 35 for Table of Contents for Test Procedures and Equipment)	34
VII. TEST SEQUENCE AND QUANTITIES	165
VIII. TEST EQUIPMENT	172
IX. TEST SPECIMEN DESIGN	180
X. TEST TUBING	187
XI. MS FITTING - BASELINE DATA	192
XII. SUMMARY	195
XIII. REFERENCES	197

LIST OF TABLES

<u>Table</u>		<u>Page</u>
1.	TEST PROGRAM SUMMARY	12
2	RECOMMENDED MINIMUM TEST SPECIMENS REQUIRED PER TYPE AND GROUP	168
3	TYPICAL SIZES FOR PERMANENT AND SEPARABLE TYPE FITTING TEST SPECIMENS	185
4	TYPICAL SIZES FOR BOSS TYPE FITTING TEST SPECIMENS	186
5	TEST TUBING WALL THICKNESSES (NOMINAL).	188

PRECEDING PAGE BLANK NOT FILMED

I. INTRODUCTION.

The tube fitting evaluation program was initiated to achieve several milestones in the area of advanced permanent and separable fitting designs that would be compatible with the program basic requirements. The fitting industry was contacted in an effort to locate and investigate new designs or concepts that are in current production along with associated assembly and installation equipment. Many new designs were quickly eliminated because of the basic requirements: 4,000 psi operating pressure within the temperature range of -65°F to +450°F while also being compatible with 21-6-9 and Titanium 3Al-2.5V tubing alloys. The current state-of-the-art provides fitting designs that predominantly utilize swaging, welding and the induction braze method of assembly with tue tubing. There appears to be four basic types of fitting/tubing assembly methods:

- Brazing
- Welding
- Swage
- Cryofit (shrink)

It was decided that the test program would attempt to encompass all four assembly methods and fabricate test assemblies into permanent and separable type fittings with two boss designs compatible with the separable designs where possible. These fittings would be procured "over-the-counter", with assembly to be accomplished by the fitting manufacturer utilizing tubing specimens furnished by the testing agency. -

A data review on fittings and related testing revealed that testing to currently available standards can produce a wide variation in test results due to the various interpretations of the standards with respect to methods, procedures and equipment design/operation. One of the primary goals of this program is to develop a standard overall test program including methods, procedures and equipment as well as recommended test sequences for qualifying fitting/tubing assemblies. This would permit correlation of test data/results from any qualified fitting manufacturer or airframe manufacturer.

The program consisted to testing the MS flareless (separable) fitting and utilizing the results as baseline data from which all other fittings will be evaluated. Five separable designs and five permanent designs were tested in three sizes (-6, -10 and -16) with two types of tubing materials (21-6-9 and 3AL-2.5V). Each participating vendor will receive a copy of the basic report, Volume I, which includes discussions of the MS baseline tests as well as discussions on the test procedures and various tubing materials. In addition, each vendor will receive a copy of the test results applicable only to his own product and the MS baseline data test results.

II. PROGRAM BACKGROUND AND REQUIREMENTS.

Design requirements of future aircraft plumbing systems necessitates an increase in operating pressures as well as operating environment. The MS flareless fitting and many other fittings available on today's market will not meet the increased requirements. Closely associated with the problem of fittings is the tubing material and wall thickness as well as flaws in the tubing and fittings. Therefore, ASD developed a program to determine exactly what was available on today's market and/or design boards that would meet the demand of these futuristic requirements. These requirements are not unrealistic, as have been proven on the SST and B-1 aircraft programs.

The program was then set up to acquire the latest designs from the fitting industry and then have them assemble their fittings with test tubing furnished by the contractor. The tubing was procured by the contractor to rigid specifications (including ultrasonic inspection) in order to aid the failure analysis. The tubing was then cut and shipped to the fitting manufacturer for assembly with the designated fittings to form the test specimens.

One of the basic requirements in aerospace system design is minimum weight and this requirements is applicable to both the permanent fittings, separable fittings and tubing. Normally the minimum wall thickness tubing will be used to achieve the maximum in weight reduction. Therefore, the tubing is susceptible to fatigue especially if a flaw or stress riser exists. The data review indicated that the predominance of failures

occurred in the tubing and not in the fitting. Also, the greater percentage of failures occurred adjacent to (within two tube diameters) the fitting joint. Several reasons could be attributed to the proximity of these failures such as:

- Change in section properties at the junction of tube and fitting
- The brazing, swaging or welding operation with related high temperatures or work hardening could affect the tubing material within a certain area of the joint
- The critical stress point often occurs at the junction of fitting/tubing

After reviewing the various test programs that have been conducted along with a review of the system failures that have been documented, it is noteworthy that very few failures actually occur in the fitting itself (permanent or separable) and the critical area is the interface or joint between the fitting and tubing. This is the area where the primary emphasis is centered for future designs and it is also the area where the test procedures and test equipment design will be focused. Another critical area is the tubing and the associated flaws or defects that reduce the fatigue life. The results of the numerous tubing tests should provide useful data with respect to tubing surface conditioning, non-destructive inspection (NDI) and texture control.

In order to encompass the complete test spectrum for tube-fitting qualification requirements fifteen (15) separate tests were recommended as follows:

- *- Repeated Assembly
- Proof and Burst
- Rotary Flexure (Room Temperature and 400 psi)
- Rotary Flexure (Room Temperature and 4000 psi)
- Rotary Flexure (450°F and 4000 psi)
- Impulse
- *- Misalignment and Assembly Torque
- Thermal Shock and Stress Corrosion
- Tube Restraint* and Axial Pull
- Vibration
- Fire Resistance
- *- Structural Load Relaxation

Proof pressure, burst pressure and gaseous leakage tests are used throughout the test sequences at opportune points to verify the integrity of the test specimens following any designated test or operation. The separable type fittings necessarily receive more tests than the permanent type fittings due to the more complicated joint and potential failures or leak paths associated with the interface. The test conditions for the new Class I fittings/tubing would include:

Operating Pressure	- 4000 psi
Proof Pressure	8000 psi
Burst Pressure	16,000 psi
Max. Operating Temperature	450°F
Min. Operating Temperature	-65°F

Using the appropriate references as a guide, the test methods, procedures and equipment were developed to generate the most meaningful

*Applicable to separable designs only.

test and useful data. These items are discussed in greater detail in subsequent sections.

In addition to the new fitting designs, it was also agreed that no reliable data existed on the MS flareless fittings and 304 1/8 H CRCS tubing, the combination of which would furnish usable baseline data if tested to appropriate specifications. Since the MS flareless fittings have gained considerable experience to date in the aerospace field, it was decided to subject similar test specimens, assembled with MS unions, to the same series of tests with the following Class II test conditions:

Operating Pressure	3000 psi
Proof Pressure	6000 psi
Burst Pressure	12000 psi
Max. Operating Temperature	275°F
Min. Operating Temperature	-65°F

The remaining requirements are discussed in detail throughout the subsequent sections.

III. DATA REVIEW

One of the program requirements was a review of the related data

listed as follows:

Military Specifications

MIL-F-18280 Fitting, Flareless Tube, Fluid Connection
MIL-F-5509 Fittings, Flared Tube, Fluid Connection
MIL-F-27417 Fittings, Rocket Engine, Fluid Connection

Military Standards

MS 33649 Bosses, Fluid Connection - Internal Straight Thread
MS 33566 Fitting, Installation of Flareless Tube - Straight Threaded
Connector
AND 10064 Fitting, Installation of Flared Tube, Straight Threaded
Connectors
MIL-STD-810 Environmental Test Methods

NASA Specifications

KSC-F-124 Fittings/Pressure Connections/Flared Tube
MSFC-SPEC-143 Fittings, Flared Tube/Premium Quality/Pressure
Connections, Specifications for

Industry Specifications

ARP 899 Connectors and Connections, Fluid System - Permanent Type
ARP 1055 (Proposed) Fire Resistance and Fire Test Requirements
for Fluid System Components

Technical Reports

AFAPL-TR-69-67 Titanium 6AL-4V Hydraulic Plumbing for Advanced
Aerospace Vehicles
AF RPL-TR-65-161 Exploratory Development Work on Families of
Welded Fittings for Rocket Fluid Systems
RPL TDR 64-24 Applied Research and Development on Families of
Brazed and Welded Fittings for Rocket Propulsion Fluid
Systems
AFRPL TR 65-162 Development of AFRPL Threaded Fittings for
Rocket Fluid Systems

RTD TDR 63-1115 Development of Mechanical Fittings - Phases I
and II
ASD TR 61-486-Metallic Boss Seal Evaluation and Test Program
RPL TDR 64-25 Aerospace Fluid Component Designers Handbook
Vols 1 and 2
NA 60-648 Evaluation of AM 350-CRES Hydraulic Tubing and LD
273-0001 Union - Brazed Tube for 4000 PSIG Hydraulic
Systems Applicable to XB-70 Airplane
WADC TR 59-267 Hydraulic and Pneumatic Fitting and Tubing Test
Program
WADC TR 55-163 Testing of Metal Boss Seals

In addition, the following documents were reviewed:

NASA TR-324-D, "Test Report -- Lockheed Industrial Products -
Modified AN Fittings" - May 27, 1966
NASA CR-952, "Leakage Testing Handbook" - April 1968
NASA, "Proceedings of the Conference on the Design of Leak-Tight
Fluid Connectors" - March 1964
NA-66-1141, "Hydraulic Plumbing for Advanced Aerospace Vehicles,"
October 12, 1966
WADC-TR-54-189, "Theoretical Investigation of Optimum Pressures
in Aircraft Hydraulic Systems" - January 1954
LTV-2-501000/8R-2479, "Development of Hydraulic System Field
Repair Kit Using Adhesive Bonded Permanent Joints," Proposal -
February 1968
ASN-JP-20-70-2, "Fluid Power Technologies - SAE-A-6 Committee
Index of Minutes"
AFML-TR-71-156, "Diffusion Welding of Wrought Beryllium,"
T. J. Bosworth, Boeing Company
BAC-S11AU (30.31) 12/14/70 Std. "Seal, Boss, Titanium"
BAC-2071, "Groove Configuration - Titanium Boss Seal"
ARP 994 (Proposed 27 August 1971) SAE A-6 Committee "Recommended
Practice for the Design of Tubing Installations for Aerospace
Fluid Power Systems"

NASA - Tech. Brief 71-10266, "Criteria for Vibration Testing,"
August 1971

Meeting Minutes #61 - SAE G-3 Committee - July 1971

Meeting Minutes #70 - SAE-A-6 Committee - March 1971

Meeting Minutes - "Hydraulic Titanium Tubing & Fitting Conference,"
AFSC/ASD/ENJPF - July 1971

Papers for SAE-A-6 Committee Meeting

"Fluidic Gas Power Sources," Dr. A. E. Schmidlin - Picatinny
Arsenal - October 1971

"Need for Particle Size Standards in Fluid Contamination Measure-
ments" - L. D. Carver and M. C. Lambert (HIAC) - October
1971

"Long Life Dynamic Seals for Hydraulic Flight Control Actuators and
Other High Cycle Rate Components," Hans G. Krause, Boeing
Company, October 1971

Review of the above listed documents was covered under a separate
phase of the program. Several benefits were derived from the Data Review,
but the most significant was the large degree of difference that existed
with respect to the number and types of tests, methods, procedures and
equipment used by each facility in testing tube/fittings. These differences
created significant changes in results and renders correlation of data an
impossible task because there is no standard to use as a basis.

IV. TEST PROGRAM

The proposed test program was prepared and submitted for ASD approval following consideration of the various factors that are required,

such as:

- All Class I fittings to be procured must be compatible with:
 - (a) Armco 21-6-9 CRES tubing (-6, -10 and -16)
 - (b) Titanium 3Al-2.5V (-6, -10 and -16)
- All Class I fittings shall be tested to:
 - 4,000 psi operating pressure
 - 450° F max. temperature
 - 65° F min. temperature
- Class II fittings (MS only) shall be tested to:
 - 3000 psi operating pressure
 - +275° max. temperature
 - 65° F min. temperature
- Class II fittings shall be tested with:
 - 304-1/8H CRES tubing (-6, -10 and -16)
- All tubing to be purchased to detailed specifications
- Minimum wall thickness for test tubing to be .020"
- Each of three sizes of tubing to utilize one wall thickness per material
- Each vendor must be capable of providing fittings in three sizes: -6, -10 and -16 for separable and/or permanent fittings
- Each vendor must be able to assemble (or have assembled) the fittings with the two types and three sizes of tubing noted above

The test program was to be structured to include as many fitting designs as economically possible of the permanent and separable type with each design to receive the appropriate tests listed in Section 2. In addition, boss designs would be selected and tested in accordance with the separable fitting requirements. In order to simplify the total requirement a summary is presented in Table 1 wherein the permanent, separable and boss fittings/designs are each designated as to which tests they will receive. Each permanent and separable fitting (including MS flareless) will be tested in sizes -6, -10 and -16. The 304-1/8 H tubing with MS fittings will be tested at the lower pressures and temperatures.

Baseline data shall be acquired on MS flareless separable fittings per MIL-F-18280; these tests shall be conducted on sizes (-6, -10 and -16) using Class II temperature/pressure conditions. However, detailed test procedures will be developed for each test that can be applicable to all types of fittings.

The test plan was structured to include, as a minimum, the following tests and test requirements:

Repeated Assembly Test (for separable designs only) - This test shall consist of assembly and disassembly a minimum of 8 times. Various combinations of maximum torque, minimum torque, relative rotation of mating parts, and interchange of mating parts shall be used. Seal replacement, if required, shall be in accordance with the manufacturer's instructions. During the course of the above assembly procedures for the

TABLE 1
TEST PROGRAM SUMMARY

Test	Permanent		Separable**	
	21-6-9	Titanium	21-6-9	Titanium
*Repeated Assembly	O	O	X	X
Proof/Burst Pressure	X	X	X	X
Rotary Flexure I	X	X	X	X
Rotary Flexure II	X	X	X	X
Rotary Flexure III	X	X	X	X
Impulse	X	X	X	X
*Misalignment and *Tube Restraint	O	O	X	X
Thermal Shock and Stress Corrosion	X	X	X	X
*Vibration	O	O	X	X
Fire Resistance	X	X	X	X
*Assembly Torque and Axial Pull	O/X	O/X	X	X
Creep	O	O	X	X

*Applicable to separable fittings only.

**The separable tests also apply to bosses.

assembly torque test, data shall be recorded on the stresses noted in the tubing, when the coupling nut is torqued to its proper value. Proof pressure shall be applied at the conclusion of each test and a minimum of two other times spaced at equal intervals throughout the test. A minimum of two test articles shall be used for each size and tubing material tested.

Proof Pressure Test - Proof pressure testing is to be conducted at appropriate times during the program. Test procedures shall be developed with ARP 899 as a guide using the highest operating temperature of the fitting class under consideration and a test pressure of two times the design operating pressure.

Burst Pressure Test - Burst testing will be conducted as a destructive pressure test using ARP 899 as a guide and utilizing the highest operating temperature of the fitting class under consideration and a test pressure of four times the design operating pressure. This test shall be conducted after the test specimen has been exposed to the highest operating temperature of its class for a period of 10 hours.

Impulse Test - This test is to be conducted for 250,000 cycles using a "square" pressure wave per MIL-F-18280C, Figure 2, as a guide. The ambient temperature shall be cycled during the test a minimum of five times between -65 °E and the highest operating temperature of the class under consideration; at least 75 percent of the test time shall be at the highest temperature. The impulse rate shall be no greater than 70 cycles

per-minute. A minimum of four test articles shall be used for each size and tubing material tested.

Gaseous Leakage Test - The contractor shall devise a suitable gaseous leakage test to be applied at appropriate times during the testing. Tests shall be conducted at the highest operating temperature of the class of fittings under consideration and at both 100 psi and the design operating pressure.

Rotary Flexure/Fatigue Tests - Stress/cycle (S-N) fatigue tests shall be conducted by the contractor for fittings mated with tubing of sizes (-6, -10 and -16). In addition, these tests shall also be conducted on the MS flareless fittings mated to MIL-T-6845 (Type 304, 1/8 hard) tubing. An internal pressure equal to the design operating pressure shall be applied to half the test specimens with the specified bending loads superimposed; tests on the other half of the compliment of fatigue specimens shall be tested with pressure sufficient only to determine leakage. All tests will be performed using the rotary flexure technique. Two test temperatures will be used, viz., room temperature and the highest operating temperature of the class of fitting under consideration. For each size, and at both temperatures, S-N diagrams will be constructed for tests performed with, and tests performed without, internal pressure.

Thermal Shock Test - This test is to be conducted using ARP 899 as a guide.

Vibration Test (separable designs only) - A suitable test shall be devised by the contractor to determine the susceptibility of each separable design to loosening and failure when subjected to a vibration environment. MIL-STD-810 b shall be used as a guide for this test.

Fire Resistant Test - This test is to be conducted in accordance with procedures developed using as a guide ARP 1055. Class "A" test at a pressure equal to the design operating pressure and a fluid temperature of the highest operating temperature of the class of fittings under consideration. Fluid flow rate in gallons per minute shall be equal numerically to the square of the inner diameter of the tube when expressed in inches.

Axial Pull Test - The contractor shall devise a test to determine the ability of each design to resist an axial tensile load applied to the attached tubing.

Misalignment Test - The contractor shall devise a suitable test to determine the ability of each design to accommodate a condition whereby the axes of the tubes are not collinear.

Tube Restraint Test (separable designs only) - The contractor shall devise a suitable test to determine the ability of each separable design to accommodate a condition whereby the tubes are restrained so that the mating surfaces of the fitting are not in contact when the assembly process is initiated. The assembly process, therefore, must overcome this mismatch in order to make a connection.

Stress Corrosion Test - This test is to be conducted in accordance with procedures developed using ARP 899 as a guide except that alternate immersion cycling shall be used in place of the standard salt spray test. Alternate immersion consists of submerging the test article in a representative corrosive medium, then extracting the specimen and allowing it to dry thoroughly. The cycle is repeated continuously for the duration of the test.

Structural Load Relaxation Test (Creep) (separable designs only) - The contractor shall devise a suitable test to determine the ability of each separable design to resist relaxation of the structural loads in the joint which may occur solely as a function of elapsed time and elevated temperature.

Rotary Flexure Test - These tests are for the purpose of verifying the endurance limit tentatively established by the fatigue tests specified in Rotary Flexure Fatigue Tests and shall be conducted so as to impart 360° bending loads to all tube-to-fitting-attach points of each flexure test article. Although sufficient internal pressure shall be applied to detect any leakage which might occur during the test, the pressure stresses shall not contribute measurably to the loading of the joint. Tubing and fittings for this test shall be of sizes (-6, -10 and -16).

First, a test procedure was developed to fill each of the above requirements. These procedures were submitted for ASD approval. It must be emphasized that the references noted in each test were used with caution "as a guide" and every item therein was questioned as to "why is it done this

way?" or "is there a better way?" or "what are we really looking for?" For some tests, no references existed and SwRL procedures for these were developed to be applicable to tube/fitting design/test criteria. Several specifications were revised during the course of this program and where possible, information or data was contributed to aid in composing the revision.

Following completion of the test procedures, the test sequence was developed in an effort to determine a logical combination of some test specimens in order to achieve the maximum utilization of each test specimen. Unfortunately, any severe test on a specimen normally renders the specimen unfit for other tests and therefore twelve (12) separate test sequences resulted from the investigation. These test procedures and sequences are covered in subsequent sections with greater detail.

Test equipment for each of the above listed requirements appears to be the area of greatest difficulty due to the variations in interpreting the test specifications such as the ARP series. Every test apparatus or machine that is fabricated is subject to the designers interpretation of the requirements and specifications. In some specifications, more details are provided than others. The items that are critical to the test must be presented in detail with reasons for the design and/or operation. Completion of all test equipment revealed that only one machine would accomplish two tests: rotary flexure and rotary flexure fatigue. The tensile test machine is used for the axial pull and tube restraint tests.

The MS fitting baseline data fittings were tested following the check-out of the equipment and solving the numerous problems that always arise as new equipment is put to work. This was accomplished while the vendors were fabricating and assembling the fittings with the tubing specimens. In this manner both the equipment and procedures are thoroughly tested prior to embarking on the 21-6-9 and 3AL-2.5V test specimens.

V. SURVEY OF INDUSTRY

The objective of the requirement to survey the tube fitting industry

was to obtain answers to the following questions:

- (a) Will the number and types of test specimens required be available within the time constraints of the program?
- (b) Does a specific method of attaching fittings to the tubing exist for both initial or production installation and depot/field level repairs?
- (c) Has the equipment required for joining tube fittings to tubing been developed -- and is it operational? In this regard, are the power requirements consistent with the types and quantity of power commonly found in aircraft maintenance facilities?
- (d) Do the tube joining procedures incur any condition abnormally hazardous to personnel?
- (e) Will the contractor be permitted to either assemble (under the vendor's direction) or to witness the assembly (at the vendor's plant) of the test specimens required in this program?
- (f) Will the design withstand the required temperature and pressure limits set forth in the test program?
- (f) Is the separable design compatible with an existing boss design?
- (h) What are the prices for the -6, -10 and -16 union fittings?

During these contacts, an exchange of information often revealed if any new designs were "on the board", or if special equipment was required to assemble the fittings. In some cases the fitting manufacturers utilize existing production facilities as subcontractors and utilize whatever equipment that is available on the subcontract market while others let the purchaser assemble the fitting to the tubing any way he desires. Many of the manufacturers produce only specialized fittings (other than aerospace)

such as industrial, automotive, heavy equipment, hoses, surgical equipment, etc., because they report the aerospace field is overcrowded and quite often the airframe manufacturers develop and produce their own designs and/or fittings. Some companies that have predominantly produced aerospace fittings are swinging back to the industrial/automotive market because of the lack of activity and the above noted reasons.

During the market survey it became evident that the fitting industry was not interested in the competitive test program wherein a winning design would be selected and a MIL Standard developed and issued for the chosen design. This program required that the participating vendors submit their trade secrets, patents, designs, copyrights, etc. Only two vendors were interested in pursuing this program, leaving out some of the more promising designs. The program objective was then changed to an all-encompassing industry evaluation program wherein fittings would be purchased from the selected vendors/designs for assembly with contractor-furnished test tubing. This approach was received with interest by industry to the extent that more vendors wanted to participate than the program could economically accommodate. Therefore, a selection was made based on the optimum number of different designs. Basically, four advanced types (or designs) of tube/fitting joints exist today:

- Brazed joint
- Welded joint
- Swaged joint
- Shrink fit joint

In addition, there is the MS flareless fitting joint from which several joint designs were developed. All of the designs selected for the test program have a metal-to-metal seal in the separable fitting joints. The final selection of participants resulted in the following:

- 5 separable designs
- 5 permanent designs
- 2 boss designs
- MS flareless fitting (separable) for baseline data

VI. TEST PROCEDURES

The development of procedures by which each test is to be conducted is considered to be one of the key tasks within the program because it is anticipated that hereafter, all future fittings will be qualified to this specific series of detailed tests using the exact procedure and equipment. In this manner, all future test results will be correlatable, especially if identical test equipment and data format is used by each vendor along with the prescribed test procedures. The following list of test procedures for Class I and Class II fittings are contained in this section:

- (1) Repeated Assembly Test (Separable Designs Only)
- (2) Proof Pressure Test
- (3) Burst Pressure Test
- (4) Combined Proof-Burst Pressure Test
- (5) Impulse Test
- (6) Assembly Torque and Misalignment Test (Separable Fittings Only)
- (7) Axial Pull and Tube Restraint Test (Tube Restraint Test for Separable Designs Only)
- (8) Structural Load Relaxation Test (Separable Designs Only)
- (9) Gaseous Leakage Test
- (10) Class "A" Elongation Resistance Test
- (11) Thermal Shock
- (12) Stress Corrosion
- (13) Vibration (Separable Fittings Only)

(14) Rotary Flexure

(15) Fatigue

Development of each of the above listed test procedures is discussed in the following paragraphs.

- (1) Repeated Assembly Test. The objective of this test is to determine the degree of deterioration in a separable joint and seal after successive disassembly and reassembly operations. Therefore, a pressure check is performed after each of four successive assembly/disassembly operations using the fitting manufacturers recommended range of torque values. Interchanging the mating parts also offers variations that are of concern. These operations are repeated under controlled laboratory conditions and will result in correlatable and repeatable data while furnishing an indication of the fittings capability. This is a rather simple test and requires a minimum of equipment with a close inspection/examination for the deterioration. This test is applicable only to the separable type of fitting.
- (2) Proof Pressure Test. This verification test is to be used "as-required" throughout the various test sequences to verify the integrity of the fitting/tubing/joint at any particular point, but more especially following a critical test. The actual test for proof pressure is combined with the test for burst pressure

as noted in Procedure No. 4. The burst test equipment is designed for a maximum of 30,000 psi. Adequate protection must be provided in design of the equipment in the event of a failure. The high temperature heating system must be protected from oil spray to prevent fires. A CO₂ fire fighting system should be installed in the burst pressure chamber or insure that it is sealed tight enough so as not to support combustion. Proof pressure is defined as two times the operating pressure. Proof pressure can be applied to any fitting/tubing assembly prior to normal use without concern of permanent damage.

- (3) Burst Pressure Test. Burst pressure is defined as four times the designated operating pressure. However, each assembly must withstand four times operating pressure without failure but with considerable deformation. During this test series, the destructive burst test will be used wherein the assembly is pressurized to four times operating pressure and held for ten seconds prior to continuing the pressure increase to failure of tube or fitting. This particular procedure is also used to study the deterioration in an assembly following a series of other type tests. The actual burst test to new specimens is noted in the combined proof and burst test in Test Procedure No. 4.

- (4) Combined Proof and Burst Test. The actual tests for proof and burst pressures were combined since they follow in logical sequence. Most all fitting assemblies will pass the proof test without any problems. Therefore, the specimen is preconditioned and then taken to two times operating pressure and held for the recommended period of time before going to three and four times operating pressure for a 10-second pause. Finally, the specimen is pressurized until a burst failure occurs. These test specimens must be new specimens without any prior tests or damage, while Test Procedures 2 and 3 apply to verification pressures before, during or after the test.
- (5) Impulse Test. The impulse test was first designed around the requirements presented in MIL-F-18280. However, after operating the test apparatus with instrumented assemblies and the required rate of rise, we found that the specimens were not receiving the impulse energy supposedly imposed by the initial pressure with a rise rate of 180,000 psi/second. The pressure spike was too sharp, thereby containing negligible energy. The test apparatus was modified to reduce the input pressure rise time to insure that the assembly received the maximum pressure and that the two-step pressure reduction to zero was clean and sharp. Later it was found that the Boeing

Company was also investigating this same theory as presented in SAE Paper 700789.* Figure 1 presents the pressure/time curve required per MIL-F-18280, and Figure 2 presents the SwRI recommended curve. The dotted line represents the type of pressure/time curve recommended by Boeing in the above noted SAE paper. The Institute is in full agreement with the impulse pressure wave shape for testing as recommended by Boeing. The impulse tests conducted by SwRI during this program used the pressure/time wave shape noted in Figure 2.

- (6) Assembly Torque and Misalignment Test (Separable Fittings Only). These two tests were combined because the test fixture for the misalignment test could easily be used for the assembly/disassembly torque test. The purpose of the misalignment test is to determine how great an angular offset could be imposed on the separable fittings and still effect an assembly and satisfactory seal. The question that requires consideration is the length of the half of tube on the deflected half of the union. The shorter the tubing, the less the bending deflection and therefore, the more accurate the angle at the interface. These data are primarily for design data, but are also

*Future Airplane Hydraulic Distribution Systems Design, Developments and Testing Criteria by R. W. Mutzke, W. G. Nelson and J. H. Van der Velden

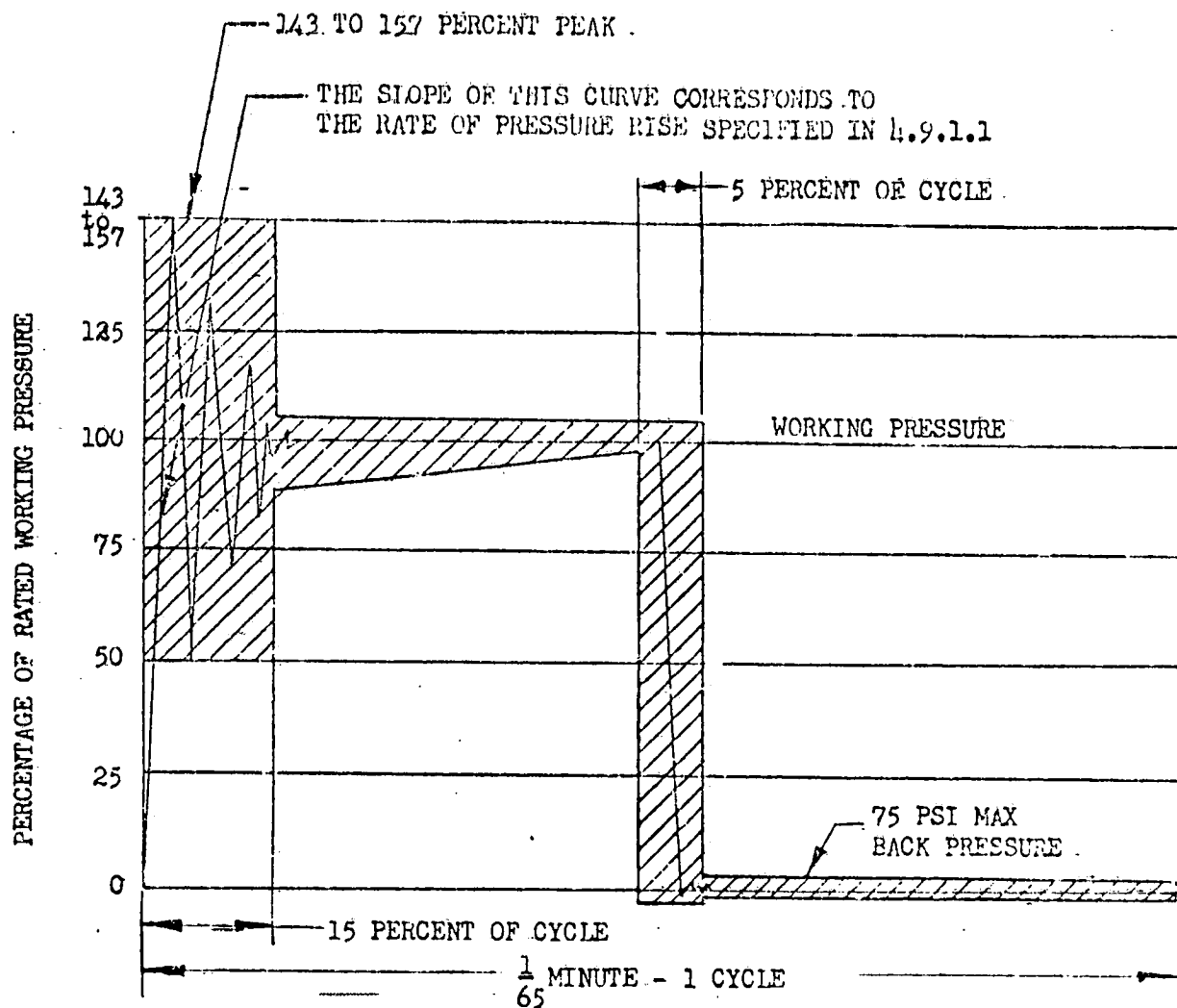

THE CURVE SHOWN ABOVE IS THE APPROXIMATE PRESSURE-TIME CYCLE DETERMINED TO BE OF PROPER SEVERITY FOR IMPULSE TESTING OF FLARELESS FITTINGS. WHILE IT IS MANDATORY ONLY THAT PRESSURE PEAK RISES TO 143 TO 157 PERCENT OF THE WORKING PRESSURE AT SOME POINT PRIOR TO LEVELING OFF AT RATED PRESSURE, IT IS CONSIDERED HIGHLY DESIRABLE THAT THE PRESSURE-TIME CURVE BE CONFINED TO THE SHADED AREA INDICATED. ONE VERY DESIRABLE BENEFIT TO BE GAINED IN THIS MANNER IS THAT RESULTS OF TESTS PERFORMED ON DIFFERENT TEST MACHINES WILL BE MORE NEARLY COMPARABLE.

FIGURE 1 DYNAMIC PRESSURE IMPULSES RECOMMENDED
IN MIL-F-18280C

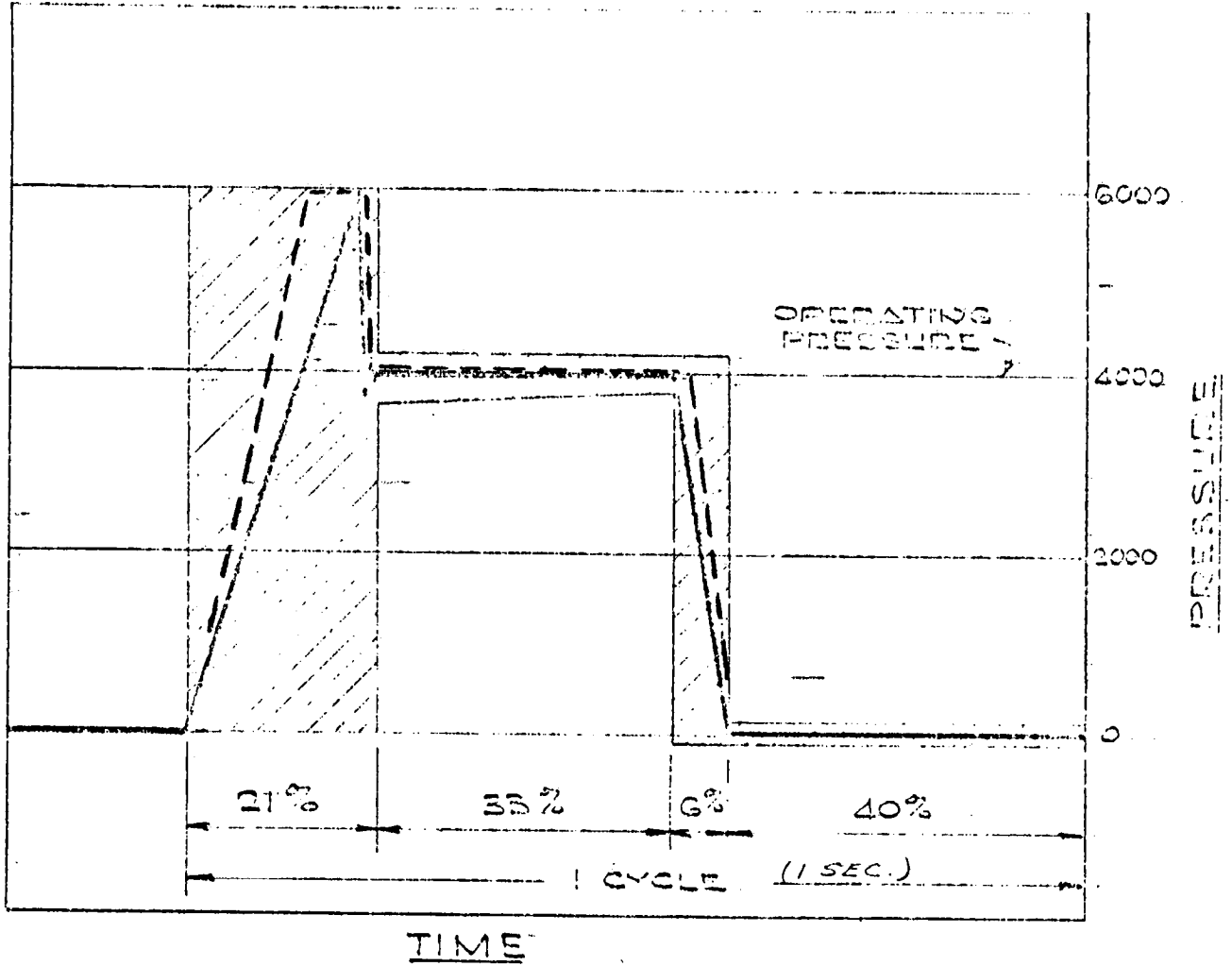

- Recommended maximum energy pulse shape
- Pulse shape used by SwRI

Cyclic Rate: 60 cycles per minute
 Pressurization Rate: 192,000 psi per minute

FIGURE 2 PRESSURE VS TIME CURVE IMPULSE TEST

useful to the mechanic assembling the fitting. The assembly torque measurement is to determine how much torque (tightening and loosening) is imposed on the tubing by the contact surface of the mating surfaces during the assembly and disassembly of the separable fitting.

- (7) Axial Pull and Tube Restraint Tests (Tube Restraint Test for Separable Fittings Only). The purpose of the axial pull test is to determine the tensile load required to fail the tube, fitting or interface to the point that a leak occurs in both permanent and separable fittings. The purpose of the tube restraint test is to determine the ability of the separable fitting to effect a seal with a gap existing between the two fitting halves. The gap is increased from zero to the point that a seal cannot be effected. This data will be useful to the aerospace designer, the manufacturer and the mechanic installing and assembling the separable fittings.

- (8) Structural Load Relaxation Test (Separable Fittings Only). The purpose of this test is to measure the creep or structural load relaxation in a separable fitting after the proper assembly torque has been applied. The test is to be performed with a tensile preload at elevated temperature and internal proof pressure for 100 hours. The creep is to be measured in terms of stress reduction attributed to temperature and time.

- (9) Gaseous Leakage Test. The purpose of the gaseous leakage test is to utilize a suitable gas of fine molecular structure that will penetrate openings easier than a viscous oil and measure the degree of leakage. This is a controversial test since the recent proposed revision to ARP 899 proposed elimination of the gaseous leakage test utilizing a mass spectrometer and simply accomplish a bubble check by water immersion. The Institute does not agree with the bubble check method because there is no method of calibration or varying degree of leakage detection. The gaseous leakage test is to be divided into two types of test: one to test a new fitting assembly for gaseous leakage; the second to verify the integrity of the fitting before and after a test in a manner similar to the proof pressure test.
- (10) Class "A" Fire Resistance Test. The purpose of this test is to measure the resistance of the fitting assembly to a 2,000°F flame for five minutes with a measured flow of oil flowing through the test specimen at operating pressure while the specimen is vibrated at 2,000 cpm utilizing a $\pm 1/16$ amplitude. This is a rather severe test but parallels the conditions found in an engine fire zone in the event of a fire. ARP 1055 is a state of revision since much of the original data contained therein is obsolete when applied to aerospace designs of today. The

recommended changes are included in the test procedure and equipment setup.

- (11) Thermal Shock Test. The purpose of this test is to determine the reaction of the fitting assembly to severe temperature changes, both internally and externally with liquid and air mediums. Test specimen assemblies are first subjected to the air shock from cold to hot chambers in a minimum of time using the temperature extremes. The second part of the test also uses the temperature extremes with a liquid medium injected into the specimens. A proof pressure or gaseous leakage test will be used to verify the integrity of the fitting following the thermal shock tests.
- (12) Stress Corrosion Test. The purpose of this test is to determine the resistance of the tubing, fitting and various interfaces, to a corrosive environment. This test will utilize the cyclic salt water immersion test with drying periods between each immersion. Inspection of the assemblies may require complete disassembly and possibly a cut-away to determine the degree of penetration of the corrosion into some of the mating surfaces.
- (13) Vibration Test (Separable Fittings Only). The purpose of this test is to determine the susceptibility of the separable fittings to possible loosening or damage due to the vibration test. The

test is to be conducted in accordance with MIL-STD-810B.

However, the NASA recommended Criteria for Vibration Testing. (Brief 71-10266) may offer a future change in this area of testing. Detailed inspection of the fitting joints and interfaces will reveal any damage following the vibration testing.

- (14) Rotary Flexure Test. The rotary beam method of testing will be used throughout this program for the rotary flexure test and the fatigue test. Basically, the test procedure and equipment will follow the recommendations set forth in ARP 1185 (proposed). One of the more critical problems is that of poorly aligned test specimens wherein the tube axis for both halves of the assembly is not colinear. When such a specimen is installed in the rotary flexure fixture that has a perfectly true axis, it is impossible to establish a zero once the rigid tail-stock is clamped on the tube. This alignment problem could be solved by loosening the orbital base on the tail stock; but, the eccentricity would vary by the degree of misalignment. More caution should be exercised by the vendors in preparing specimens for the rotary flexure tests (and all other tests) to insure more uniform results. The eccentric stress problem has been solved by "averaging" the maximum deviation. Two strain gages located 90° apart were used on

the initial test specimen with accurate measurements taken of the displacement because the strain gage did not last too long once the 3,200 rpm cyclic load was imposed. For the elevated temperature tests, high temperature strain gages were required to set the initial strain. The rotary flexure data can be used as the endurance limit data for the S-N fatigue curve thereby obtaining more points to establish the curve.

(15) Fatigue Test (See Rotary Flexure for General Information).

Following the rotary flexure tests, that normally will establish the endurance limit of the S-N curve, additional specimens were tested at the higher stress levels in order to establish other points on the curve.

A copy of the laboratory test procedure for each of the fifteen tests noted above is included in the following pages. A diagram of the test apparatus and/or equipment list is included with each test procedure.

TEST PROCEDURES AND EQUIPMENT

TABLE OF CONTENTS

	<u>Page</u>
LIST OF ILLUSTRATIONS	36
INTRODUCTION	37
1. REPEATED ASSEMBLY TEST	39
2. PROOF PRESSURE TEST	47
3. BURST PRESSURE TEST	52
4. COMBINED PROOF-BURST PRESSURE TEST	58
5. IMPULSE TEST	65
6. ASSEMBLY TORQUE AND MISALIGNMENT TEST	78
7. AXIAL PULL AND TUBE RESTRAINT TEST	91
8. STRUCTURAL LOAD RELAXATION TEST	100
9. GASEOUS LEAKAGE TEST	111
10. CLASS "A" FIRE RESISTANCE TEST	117
11. THERMAL SHOCK TEST	126
12. STRESS CORROSION TEST	134
13. VIBRATION TEST	144
14. ROTARY FLEXURE TEST WITH S/N DATA DEVELOPMENT	150

LIST OF ILLUSTRATIONS

<u>Figure</u>		<u>Page-</u>
1	REPEATED ASSEMBLY TEST FACILITY	42
1a	ASSEMBLY AND INSTALLATION OF BOSS TEST SPECIMEN	46
2	BURST TEST FACILITY	55
3	DYNAMIC PRESSURE IMPULSES RECOMMENDED IN MIL-F-18280C	67
4	PRESSURE VS TIME CURVE IMPULSE TEST	68
5	IMPULSE TEST FACILITY	69
6	TEST FIXTURE AND STRAIN GAGE LOCATION	83
6a	TEST FIXTURE AND STRAIN GAGE LOCATION FOR BOSSES	90
7	ASSEMBLY TORQUE-MISALIGNMENT TEST FACILITY	84
8	AXIAL PULL-TUBE RESTRAINT	94
8a	AXIAL PULL-TUBE RESTRAINT FOR BOSS TEST	99
9	STRAIN GAGE LOCATION FOR STRUCTURAL LOAD RELAXATION TEST	104
9a	BOSS TEST SPECIMEN ASSEMBLY AND STRAIN GAGE LOCATION	109
10	STRUCTURAL RELAXATION TEST FACILITY	105
10a	STRUCTURAL RELAXATION TEST FACILITY FOR BOSS TEST	110
11	FIRE RESISTANCE TEST FACILITY	121
11a	FIRE RESISTANCE BOSS TEST SPECIMEN ASSEMBLY	125
12	LIQUID SHOCK TEST ASSEMBLY	129
12a	LIQUID SHOCK TEST ASSEMBLY - BOSS	133

LIST OF ILLUSTRATIONS (Cont'd)

<u>Figure</u>		<u>Page</u>
13	STRESS-CORROSION TEST FACILITY	138
13a	STRESS-CORROSION BOSS SPECIMEN INSTALLATION	147
14	INSTALLATION OF A TEST SPECIMEN (TYPICAL)	156
14a	INSTALLATION OF A TEST SPECIMEN (TYPICAL) BOSS	163
15	ROTARY FLEXURE TEST FACILITY	157
15a	ROTARY FLEXURE TEST FACILITY - BOSS	164

TEST PROCEDURES AND EQUIPMENT

INTRODUCTION

The development of procedures used to conduct each test is considered to be one of the key tasks within the overall test program. Although efforts centered primarily on developing this particular series of tests, considerable time and research was expended to prepare a set of procedures and assemble associated test equipment that could be standardized to provide for correlative data and test results from future qualification tests on newly developed fittings.

One of the greatest problems voiced by Industry was the variance in general requirements of the many documents currently in use for testing of tube/fitting assemblies. Each manufacturer could choose the test parameters and procedures that were best suited for their product or would test it to the best advantage. Consequently, test data available on fittings today are virtually noncorrelative.

During the review of many reference documents listed for use with a particular test, it was noted that the specifications and equipment currently used were obsolete and in some cases inadequate because of the higher pressure and temperature requirements on tube fittings needed to meet the stringent environmental conditions of modern aircraft. Only ARP 1185 (proposed) and ARP 1055 (being revised) are considered the most direct and detailed tube testing specifications; but, these two must also be updated to meet current industry requirements. Therefore throughout this program, the documents noted in the RFQ were "used as a guide for reference only,"

and the SwRI Test Procedures and Test Equipment were developed to produce the optimum test results, with simple yet technically sound methods and economically constructed or readily available test apparatus.

The equipment used for each test was developed in close coordination with the design of the Test Specimens, and development of the Test Procedures and Test Sequences, because each is interdependent on the other. Industry was also canvassed to ascertain types of current equipment used, and their applicability to the new 4,000 psi/450°F fitting requirements.

The following list of Test Procedures (also referred to as Performance Evaluation Tests) for Class I and Class II fittings are contained in this section:

- (1) Repeated Assembly Test (separable design only)
- (2) Proof Pressure Test
- (3) Burst Pressure Test
- (4) Combined Proof-Burst Pressure Test
- (5) Impulse Test
- (6) Assembly Torque and Misalignment Test (separable fittings only)
- (7) Axial Pull and Tube Restraint Test (tube restraint test for separable designs only)
- (8) Structural Load Relaxation Test (separable designs only)
- (9) Gaseous Leakage Test
- (10) Class "A" Fire Resistance Test
- (11) Thermal Shock Test
- (12) Stress Corrosion Test
- (13) Vibration Test
- (14) Rotary Flexure Test with S/N Data Development (flexure fatigue)

They are presented in a format which will provide a brief resume of test objectives and equipment requirements; the test procedure itself; descriptive layouts of the test assembly where necessary; and the form used to record the test data.

1. REPEATED ASSEMBLY TEST

The objective of this test is to determine the degree of deterioration in a separable joint and seal (or sealing surfaces) after successive disassembly and reassembly operations, during which the relative positions of the mating parts are changed.

A helium leak test is conducted before the initial disassembly of the test fitting and after each group of four successive assembly/disassembly operations. The manufacturer's recommended range of torque values are used during the tests. Care must be exercised to insure that no lubrication exists on the threads or mating surfaces except that which is an inherent part of the fitting assembly such as a dry film lubricant.

The specimen holding fixture and test chamber illustrated in Figure 1 are similar to those used in the proof/burst and impulse test facilities. The leakage test is conducted in the manner outlined in the Helium Leak Test Procedure presented later in this report:

Performance Evaluation Test No. 1

REPEATED ASSEMBLY
(Separable Designs Only)
(Reference: MIL-F-18280C)

A. TEST PARAMETERS

1. Test Temperature: RTA (room temperature ambient)
2. Assembly torque loads
 - 2.1 Vendor recommended minimum.
 - 2.2 Vendor recommended maximum
3. Relative rotational position of mating parts (i. e., fitting components and tubing).
4. Relative left/right position of mating parts
5. Leakage of helium gas at 4,000 psi
6. Eight assembly/disassembly operations

B. TEST APPARATUS

1. Specimen mounting fixture (same as used for proof pressure and burst pressure tests)
2. Torque wrench (0-500 in. lb)
3. Torque wrench calibration equipment
4. Gaseous leakage test apparatus and calibration equipment

C. TEST PROCEDURES

1. Install and tightly secure assembled test specimen in specimen mounting fixture. Mark relative rotational and left/right positions of fitting components and tubing. Visually inspect fittings for any imperfections and note these on form.
2. Check vendors original assembly of complete fitting using vendor's recommended procedure and minimum torque value. Match mark relative position of tubing and fitting components in assembled configuration.

REPEATED ASSEMBLY (Cont'd)

3. Install specimen mounting fixture on test chamber manifold and conduct gaseous (helium) leak test at room temperature as outlined in Procedure 9.
4. Remove mounting fixture from test chamber and secure to work bench or other immovable base.
5. Disassemble fitting and completely separate appropriate removable parts. Conduct a visual inspection of all contact surfaces, primarily the seal area and threaded portions of the fittings, and record any evidence of possible damage.
6. Assemble complete fitting using the manufacturer's recommended procedure and minimum torque value.
7. Repeat Steps 5 and 6 three more times, each time retaining the relative left/right positions as established in Step 1, but changing the rotational position of the assembled mating parts. This completes four assembly/disassembly operations.
8. Install specimen mounting fixture on test chamber manifold and conduct gaseous (helium) leak test at room temperature as outlined in Procedure 9.
9. The above constitutes one cycle (four assembly/disassembly and a leak check) at minimum torque. Repeat Steps 4 through 8 for the second cycle using the manufacturer's maximum recommended torque values in Step 6.
10. Record all pertinent data or remarks on Repeated Assembly Test Data Sheet.

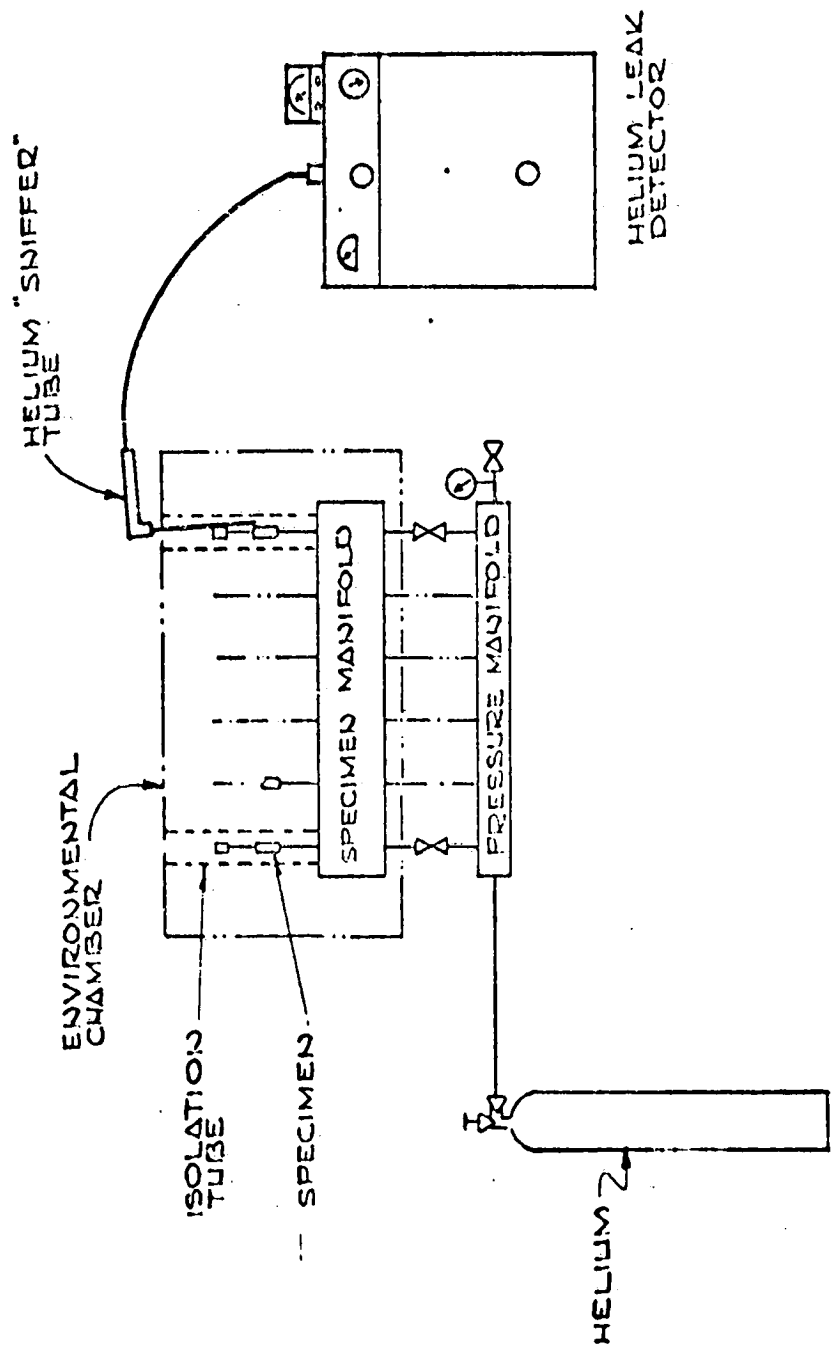

ORIGINAL PAGE IS
OF POOR QUALITY

FIGURE 1 REPEATED ASSEMBLY TEST FACILITY

SOUTHWEST RESEARCH INSTITUTE
DATA SHEET

43

SHEET NO. _____ OF _____ SHEETS
PROJECT 63-3113-02

SUBJECT TEST SEQUENCE NO. 1
GAS LEAKAGE, REPEATED ASSEMBLY, BURST

DATE _____
BY _____

SPECIMEN CODE NO.: _____

MIN. TORQUE: _____

TEST TEMP. (F°): _____

MAX. TORQUE: _____

OPERATING PRESS. (Psi): _____

GAS LEAKAGE TEST DATA:

Leak Rate Calculation Base: _____ scale $\frac{\text{sc}}{\text{sec}}$

Pressure: _____

(2 minute time interval)

Temperature: _____

Scale Reading

Calculated Leak Rate

Before First Assembly Series: _____

After First Assembly Series: _____

After Second Assembly Series: _____

ASSEMBLY/DISASSEMBLY SERIES

DISASSEMBLY TORQUE (lb/in or lb/ft)

FIRST SERIES _____

Avg. _____

Inspection Results:

SECOND SERIES _____

Avg. _____

Inspection Results:

PROOF PRESSURE TEST RESULTS:

BURST PRESSURE TEST RESULTS:

FAILURE PRESSURE: _____ PSI

Type of Failure:

SUPPLEMENT NO. 1

to

REPEATED ASSEMBLY TEST PROCEDURE
for the
TESTING OF BOSS TYPE SEPARABLE
FITTING ASSEMBLIES

REPEATED ASSEMBLY TEST
for
BOSS TYPE SEPARABLE FITTING ASSEMBLIES
(Reference: Test Procedure for Unions)

A. TEST PARAMETERS

Same

B. TEST APPARATUS

Add Items 5 and 6 as follows:

5. Adapter: Vendors boss recess to 3/4" pipe (see Fig. 1a).
6. Extension adapter for manifold to place boss in controlled environment of chamber (see Fig. 1a).

C. TEST PROCEDURES

The assembly/disassembly procedure is the same except it must be noted in Item 5 that the assembly/disassembly joint is between the tube/nut and the boss, because once a boss is installed, there is usually no reason to remove it unless the component is bad and will be discarded.

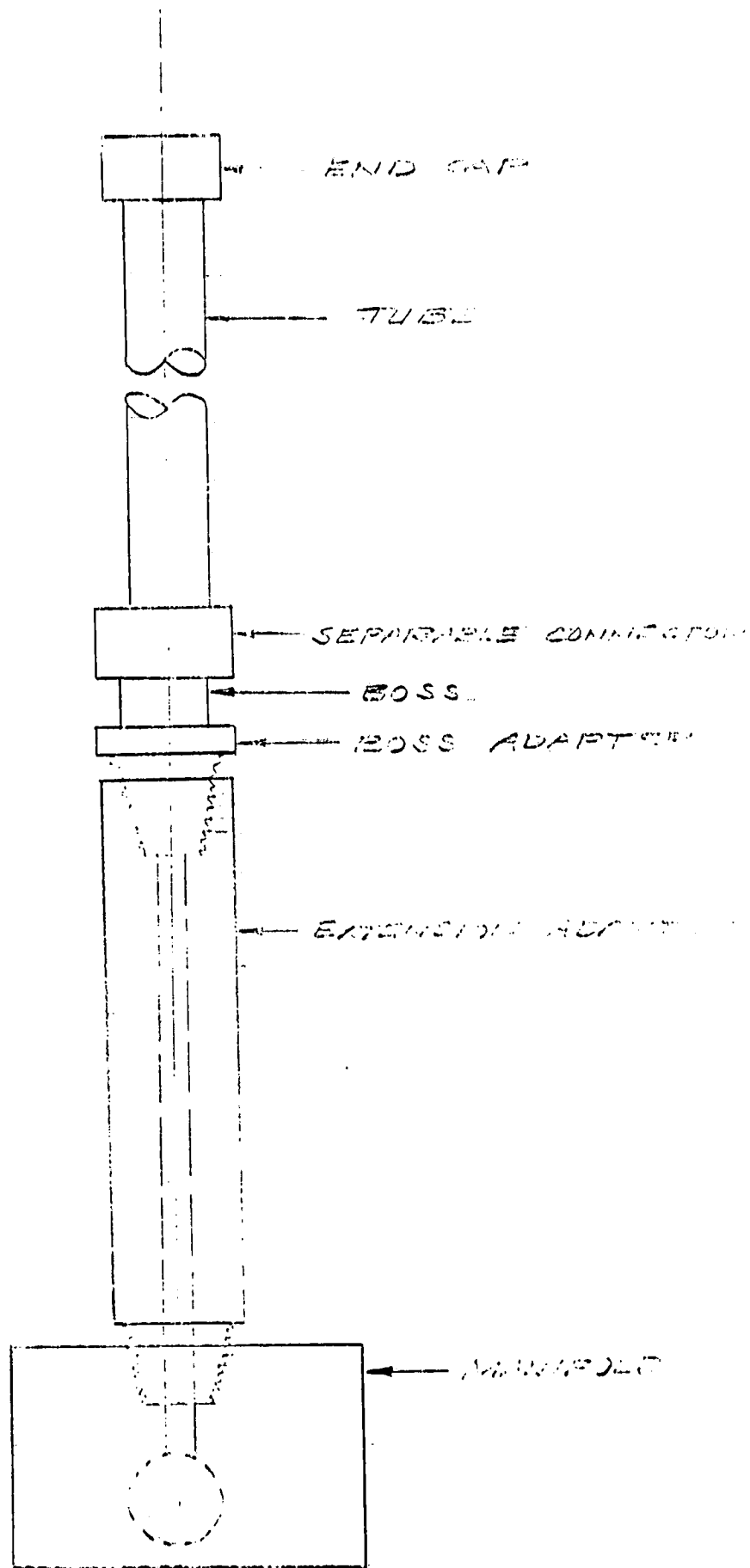

FIGURE 1a ASSEMBLY AND INSTALLATION OF BOSS TEST SPECIMEN

2. PROOF PRESSURE TEST

This verification test is to be used "as required" throughout the various test sequence to verify the integrity of the fitting assembly at any particular point, but more especially following a critical test. Proof pressure is defined as two times the operating pressure, and can be applied to any fitting/tubing assembly prior to normal use without concern of permanent damage.

The test can be conducted wherever the fitting can be pressurized to the required amount, and subjected to the highest operating temperature rating. Being closely related to the Burst Test Procedure 3, the tests are usually conducted in that test facility.

Performance Evaluation Test No. 2

PROOF PRESSURE
(Reference: ARP 899)A. TEST PARAMETERS

1. Test Pressures

- 1.1 Class I assemblies: Between 8,000 and 8,050 psig.
- 1.2 Class II assemblies: Between 6,000 and 6,050 psig

2. Test Temperatures

- 2.1 Class I assemblies: $450^{\circ}\text{F} \pm 10^{\circ}\text{F}$
- 2.2 Class II assemblies: $275^{\circ}\text{F} \pm 10^{\circ}\text{F}$

- 3. Pressurization Rate: 20,000 \pm 5,000 psig/min.
- 4. Pressure Hold Time: Minimum of 5 minutes
- 5. Test Medium: Mobil Jet Oil II or equivalent

B. TEST APPARATUS

- 1. Proof-pressure/burst chamber
- 2. Proof-pressure specimen mounting fixture
- 3. Hydraulic pressure pump (0-10,000 psig; 5 gpm)
- 4. Bourdon-type pressure gage (0-10,000 psig)
- 5. Manifold pressure control system
- 6. Chamber temperature control system (automatic)
- 7. Manifold pressure and chamber temperature, strip chart recorder system
- 8. Calibration equipment (as required for pressure and temperature instrumentation)

C. TEST PROCEDURES

- 1. Install tube fitting specimens in specimen mounting fixture

PROOF PRESSURE (Cont'd)

2. —Install specimen mounting fixture in test chamber.
3. Isolate each specimen prior to pressurization by installing isolation shields that are part of the chamber.
4. Fill specimens, pump reservoir and all interconnecting fluid lines with the specified pressurizing fluid (Item A. 5).
5. Bleed air from entire pressurized assembly by venting the highest point of the system to atmosphere.
6. Start temperature recording equipment.
7. Condition specimens for a minimum of one-hour at the elevated temperature for the Class of fitting undergoing test.
8. Start pressure recording equipment.
9. Pressurize specimens to twice the operating pressure (for the Class of fitting undergoing test) using pressurization rate of $20,000 \pm 5,000$ psig/min. Adjust manifold pressure and/or chamber temperature to within specified tolerances.
10. Hold pressure for five minutes. Monitor pressure gage and visually observe specimens during this pressure hold to detect any fitting failures. If a fitting begins to leak, immediately close the manifold valve to the defective fitting and record pertinent data in test log.
11. Upon completion of the five minute hold, reduce manifold pressure to zero and chamber temperature to room temperature.
12. Remove specimens from chamber and conduct visual inspection of fittings. For separable fittings, include a visual examination of the seals and sealing surfaces.

D. TEST RECORDS: Record all pertinent results on the Proof-Burst Test Data Sheet.

SUPPLEMENT NO. 1

to

PROOF PRESSURE TEST PROCEDURE
for the
TESTING OF BOSS TYPE SEPARABLE
FITTING ASSEMBLIES

PROOF PRESSURE TEST
for
BOSS TYPE SEPARABLE FITTING ASSEMBLIES
(Reference: Test Procedure for Unions)

A. TEST PARAMETERS

Same

B. TEST APPARATUS

Add Items 9 and 10 as follows:

9. Adapter: Vendors boss recess to 3/4" pipe (see Fig. 1a).
10. Extension adapter for manifold to place the boss and boss adapter in the controlled environmental chamber (see Fig. 1a).

C. TEST PROCEDURE

Add Item 1a to read as follows:

- 1a. For boss assemblies, install as follows:

- Install extension adapter in manifold.
- Install vendors boss adapter in end of extension.
- Install boss in recess (provided in the adapter) in accordance with vendors instructions and tools.
- Connect the separable fitting/tubing to the boss.

D. TEST RECORDS

Same.

3. BURST PRESSURE TEST

Burst pressure is defined as four times the designated operating pressure. However, each fitting assembly must withstand this pressure without failure, although considerable deformation may occur. During this test series, the destructive burst test will be used wherein the assembly is pressurized to four times operating pressure and held for ten seconds prior to continuing the pressure increase to failure of tube or fitting. The test is used both as a specific test on a new fitting (combined Proof and Burst Pressure Test Procedure 4) and as a verification check following a designated test to determine if any deterioration resulted from the test.

Since the burst test is a destructive test, the equipment is designed for a maximum of 30,000 psi pressure capability. Adequate protection is provided to prevent technician exposure to hot oil spray at high pressures when the specimen fails, and also to contain a possible fire. The burst test facility is illustrated in a descriptive diagram, Figure 2.

Performance Evaluation Test No. 3

BURST PRESSURE
(Reference: ARP 899)A. TEST PARAMETERS

1. Test Pressure
 - 1.1 Class I assemblies: Between 16,000 and 16,050 psig
 - 1.2 Class II assemblies: Between 12,000 and 12,050 psig
2. Test Temperature
 - 2.1 Class I assemblies: $450^{\circ}\text{F} \pm 10^{\circ}\text{F}$
 - 2.2 Class II assemblies: $275^{\circ}\text{F} \pm 10^{\circ}\text{F}$
3. Pressurization Rate: 20,000 \pm 5,000 psig/min
4. Pressure Hold Time: 10 seconds
5. Test Medium: Mobile Jet Oil II or equivalent

B. TEST APPARATUS

1. Burst-pressure chamber
2. Burst-pressure specimen mounting fixture
3. Hydraulic pressure pump (0-30,000 psig; 5 gpm)
4. Bourdon-type pressure gage (0-30,000 psig)
5. Manifold pressure control system
6. Chamber temperature control system (automatic)
7. Manifold pressure and chamber temperature, strip chart recorder system
8. Calibration equipment (as required for pressure and temperature instrumentation)

C. TEST PROCEDURES

1. Install specimens in the specimen mounting fixture

BURST PRESSURE (Cont'd)

2. Install the specimen mounting fixture on the manifold of the test chamber.
3. Isolate each specimen prior to pressurization by installing isolation shields that are part of the chamber.
4. Fill specimens, pump reservoir and all interconnecting fluid lines with the specified pressurizing fluid (Item A. 5).
5. Bleed air from entire pressurized assembly by venting the highest point of the system to atmosphere.
6. Start temperature recording equipment.
7. Condition specimens for a minimum of ten (10) hours at the elevated temperature for the Class of fitting undergoing test.
8. Start pressure recording equipment and isolate specimen to be tested. (Burst pressure specimens to be burst one at a time.)
9. Pressurize specimen using pressurization rate of 20,000 \pm 5,000 psig/min. Hold for ten (10) seconds at two times operating pressure, then continue to three (3) times operating pressure and hold for ten (10) seconds.
10. Continue to pressurize specimen to four (4) times the operating pressure (for the Class of fitting undergoing test) using pressurization rate of 20,000 \pm 5,000 psig/min. Adjust manifold pressure and/or chamber temperature to within specified tolerances.
11. Hold four times operating pressure for ten seconds. Monitor pressure gage and visually observe specimens during this pressure hold to detect any fitting failures. If a fitting begins to leak, immediately close the manifold valve to the defective fitting, and record pertinent data in test log.
12. Upon completion of the ten second hold, continue pressure rise at the same rate until burst occurs. Record burst pressure. Repeat Steps 8, 9 and 10 on remaining specimens.
13. Remove specimens from chamber and conduct visual inspection of fittings. For separable fittings, include a visual examination of the seals and sealing surfaces.

D. TEST RECORDS: Record all pertinent results on the Proof-Burst Test Data Sheet.

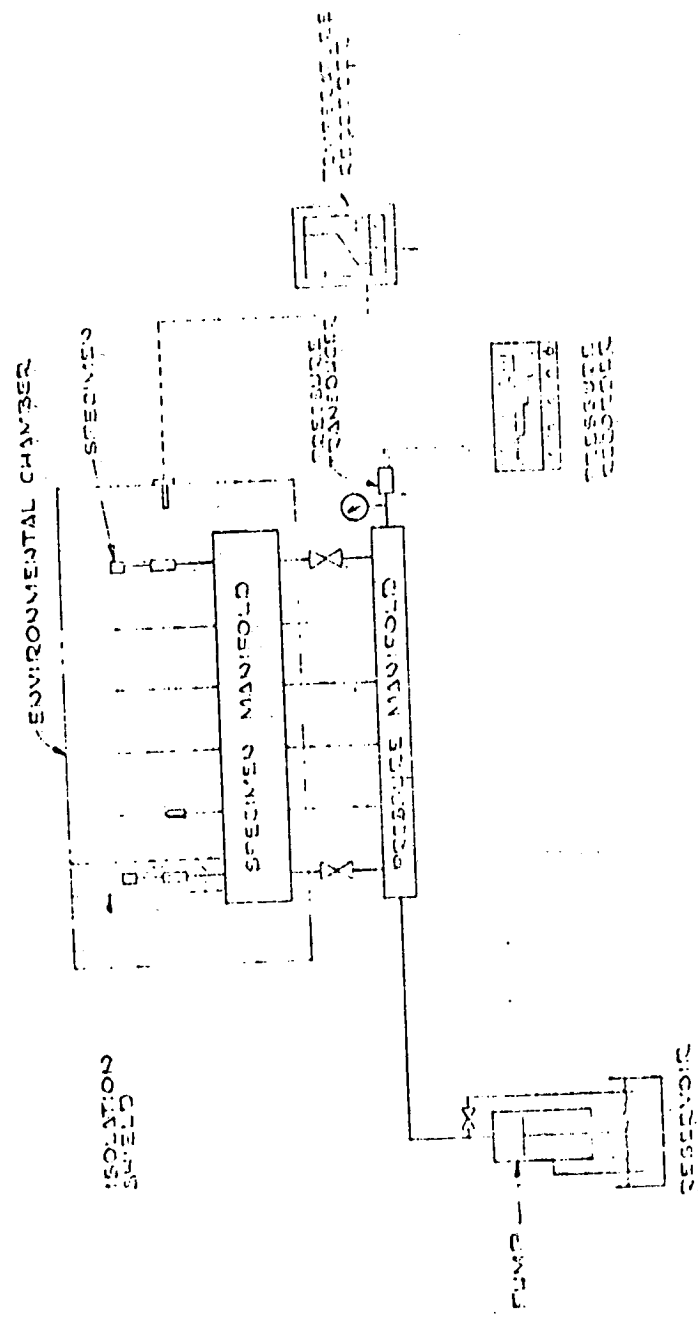

FIGURE 2 BURST TEST FACILITY

ORIGINAL PAGE IS
OF POOR QUALITY

SUPPLEMENT NO. 1

to

BURST PRESSURE TEST PROCEDURE
for the
TESTING OF BOSS TYPE SEPARABLE
FITTING ASSEMBLIES

BURST PRESSURE TEST
for
BOSS TYPE SEPARABLE FITTING ASSEMBLIES
(Reference: Test Procedure for Unions)

A. TEST PARAMETERS

Same

B. TEST APPARATUS

Same, but add Items 9 and 10 as follows:

9. Adapter: Vendors boss recess to 3/4" pipe (see Fig. 1a).
10. Extension Adapter for manifold to place the boss and boss adapter in the controlled environmental chamber (see Fig. 1a).

C. TEST PROCEDURE

Add Item 1a to read as follows:

- 1a. For boss assemblies, install as follows:
 - Install extension adapter in manifold.
 - Install vendors boss adapter in end of extension.
 - Install boss in recess (provided in the adapter) in accordance with vendors instructions and tools.
 - Connect the separable fitting/tubing to the boss.

D. TEST RECORDS

Same

4. COMBINED PROOF AND BURST TEST.

The actual tests for proof and burst pressures were combined since they follow in logical sequence. Most all fitting assemblies will pass the proof test without any problems. Therefore, the specimen is preconditioned and then pressurized to two times operating pressure and held for the recommended period of time before going to three and four times operating pressure for a 10 second pause. Finally the specimen is pressurized until a burst failure occurs. These test specimens must be new specimens without any prior tests or damage.

Performance Evaluation Test No. 4

COMBINED PROOF-BURST PRESSURE

(Reference: ARP 899)

A. TEST PARAMETERS

1. Test Pressure
 - 1.1 Class I assemblies: From 8,050 to 16,050 psig
 - 1.2 Class II assemblies: From 6,050 to 12,050 psig
2. Test Temperature
 - 2.1 Class I assemblies: $450^{\circ}\text{F} \pm 10^{\circ}\text{F}$
 - 2.2 Class II assemblies: $275^{\circ}\text{F} \pm 10^{\circ}\text{F}$
3. Pressurization Rate: 20,000 \pm 5,000 psig/min
4. Pressure Hold Time: 5 minutes
5. Test Medium: Mobile Jet Oil II or equivalent

B. TEST APPARATUS

1. Burst-pressure chamber
2. Burst-pressure specimen holding fixture
3. Hydraulic pressure pump (0-30,000 psig)
4. Bourdon-type pressure gage (0-30,000 psig)
5. Manifold pressure control system
6. Chamber temperature control system (automatic)
7. Manifold pressure and chamber temperature, strip chart recorder system
8. Calibration equipment (as required for pressure and temperature instrumentation)

C. TEST PROCEDURES

1. Install specimens in burst-pressure specimen mounting fixture

COMBINED PROOF-BURST PRESSURE (Cont'd)

2. Install specimen mounting-fixture on manifold in burst pressure chamber.
3. Isolate each specimen prior to pressurization by installing the isolation shields that are part of the chamber.
4. Fill specimens, pump reservoir and all interconnecting fluid lines with the specified pressurizing fluid (Item A. 5).
5. Bleed air from entire pressurized assembly by venting the highest point of the system to atmosphere.
6. Start temperature recording equipment.
7. Condition specimens for one hour at the elevated temperature for the Class of fitting undergoing test.
8. Start pressure recording equipment.
9. Pressurize specimens to twice the operating pressure (for the Class of fitting undergoing test) using pressurization rate of 20,000 \pm 5,000 psig/min. Adjust manifold pressure and/or chamber temperature to within specified tolerances.
10. Hold pressure for five minutes. Monitor pressure gage and visually observe specimens during this pressure hold to detect any fitting failures. If a fitting begins to leak, immediately close the manifold valve to the defective fitting, and record pertinent data in test log.
11. Upon completion of the five minute hold, reduce manifold pressure to zero, and condition specimens at 450° F for a minimum of 9 hours. Pressure recording equipment will be turned off during this conditioning period. For Class II specimens, condition at 275° F.
12. Reactivate pressure recording equipment, isolate specimen to be tested using valves and pressurize specimen to two times the operating pressure (for the class of fitting undergoing test) using pressurization rate of 20,000 \pm 5,000 psig/min and hold for ten minutes.
13. Continue pressurizing specimen using pressurization rate of 20,000 \pm 5,000 psig/min. Pressurize to three (3) times operating pressure and hold for ten seconds. Continue to pressurize specimen to four (4) times operating pressure and hold for ten seconds.

COMBINED PROOF-BURST PRESSURE (Cont'd)

14. Hold at four (4) times operating pressure for ten seconds and if no failure occurs, continue pressurization at rate specified in (12) until burst occurs.
 15. Isolate failed specimen using valves and perform test on remaining specimens one at a time. Inspect specimens in-place after temperature has been reduced to ambient.
 16. Remove specimens from chamber and conduct visual inspection and failure analysis of fittings. For separable fittings, include a visual examination of the seals and scaling surfaces.
- D. TEST RECORDS: Record all pertinent results on the Proof-Burst Test Data Sheet.

SOUTHWESTERN PIPE & Fittings Co.

SHEET NO. _____ OF _____ SHEETS

DATA SHEET

PROJECT _____

SUBJECT TEST SEQUENCE NO. II
 PROC - BURST PRESSURE

DATE _____

BY _____

TEST GROUP: _____

APPLIED TORQUE:

TYPE OF TUBING: _____

(Separable Only)

TEST TEMPERATURE: _____

TEST MEDIUM: _____

Specimen Code No.	Position No.	Temp. Condition Period		Proof Test	BURST TEST					
		Began Date	End Date		2 x Op. Pr.	3 x Op. Pr.	4 x Op. Pr.	Burst Pr. (Chart)	Burst Pr. (Gage)	

Specimen Code No.	Avg. Failure Load (Chart + Gage/2)	FAILURE DESCRIPTION

ORIGINAL PAGE IS OF POOR QUALITY

SUPPLEMENT NO. 1

to

COMBINED PROOF AND BURST TEST PROCEDURE
for the
TESTING OF BOSS TYPE SEPARABLE
FITTING ASSEMBLIES

COMBINED PROOF AND BURST TEST
for
BOSS TYPE SEPARABLE FITTING ASSEMBLIES
(Reference: Test Procedure for Unions)

A. TEST PARAMETERS

Same

B. TEST APPARATUS

Add Items 9 and 10 as follows:

9. Adapter: Vendors boss recess to 3/4" pipe (see Fig. 1a).
10. Extension adapter for manifold to place the boss and boss adapter in the controlled environmental chamber (see Fig. 1a).

C. TEST PROCEDURE

Same

Add Items 1a to read as follows:

- 1a For boss assemblies, install as follows:
 - Install extension adapter in manifold.
 - Install vendors boss adapter in end of extension.
 - Install boss in recess (provided in the adapter) in accordance with vendors instructions and tools.
 - Connect the separable fitting/tubing to the boss.

D. TEST RECORDS

Same

5. IMPULSE TEST

Initially the impulse test was designed around the requirements presented in Mil-F-18280C. However, following preliminary test work and analyzing the results, it was decided that some improvement was needed in the test requirements to provide a more severe test to the fittings. This change from the suggested test methods outlined in the work statement was justified by the common desire to conduct a test program which would "weed out" the poor designs.

The pressure/time curve as recommended by Mil-F-18280C, Figure 3, with an impulse pressure surge created by the rise rate of 175,000 psi/second, subjected the test specimen to an initial peak impulse containing negligible energy. It was felt that because of this rapid pressure-rise rate and also the fast cyclic rate, the specimen hardly sensed the peak pressure impulse at all. Therefore the test equipment was adjusted to reduce the pressure rise time and provide a somewhat slower (60 cycle per minute) cyclic rate to produce a pressure/time curve as shown in Figure 4. It is obvious that the test specimen will be exercised more strenuously with this pressure impulse pattern since the pressure rise rate has been reduced from 175,000 psi/sec to approximately 30,000 psi/sec. This theory was later found to coincide with that presented in the SAE Paper 700789⁽¹⁾ and investigated by the Boeing Co.

(1) "Future Airplane Hydraulic Distribution Systems Design, Developments and Testing Criteria" by R. W. Mutske, W. G. Nelson and J. H. Van der Velden

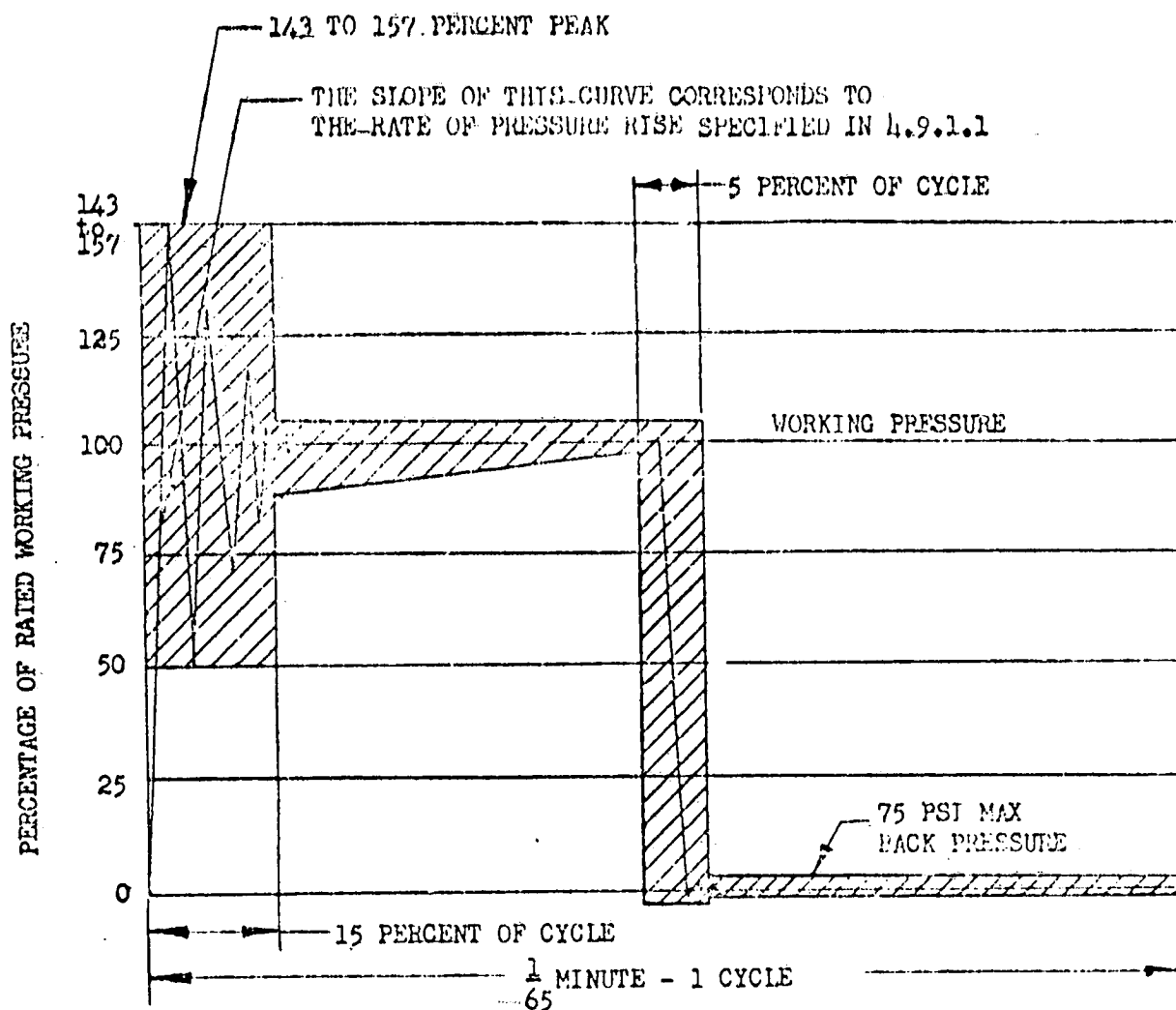

THE CURVE SHOWN ABOVE IS THE APPROXIMATE PRESSURE-TIME CYCLE DETERMINED TO BE OF PROPER SEVERITY FOR IMPULSE TESTING OF FLARELESS FITTINGS. WHILE IT IS MANDATORY ONLY THAT PRESSURE PEAK RISES TO 143 TO 157 PERCENT OF THE WORKING PRESSURE AT SOME POINT PRIOR TO LEVELING OFF AT RATED PRESSURE, IT IS CONSIDERED HIGHLY DESIRABLE THAT THE PRESSURE-TIME CURVE BE CONFINED TO THE SHADED AREA INDICATED. ONE VERY DESIRABLE BENEFIT TO BE GAINED IN THIS MANNER IS THAT RESULTS OF TESTS PERFORMED ON DIFFERENT TEST MACHINES WILL BE MORE NEARLY COMPARABLE.

FIGURE 3 DYNAMIC PRESSURE IMPULSES RECOMMENDED
IN MIL-F-18280C

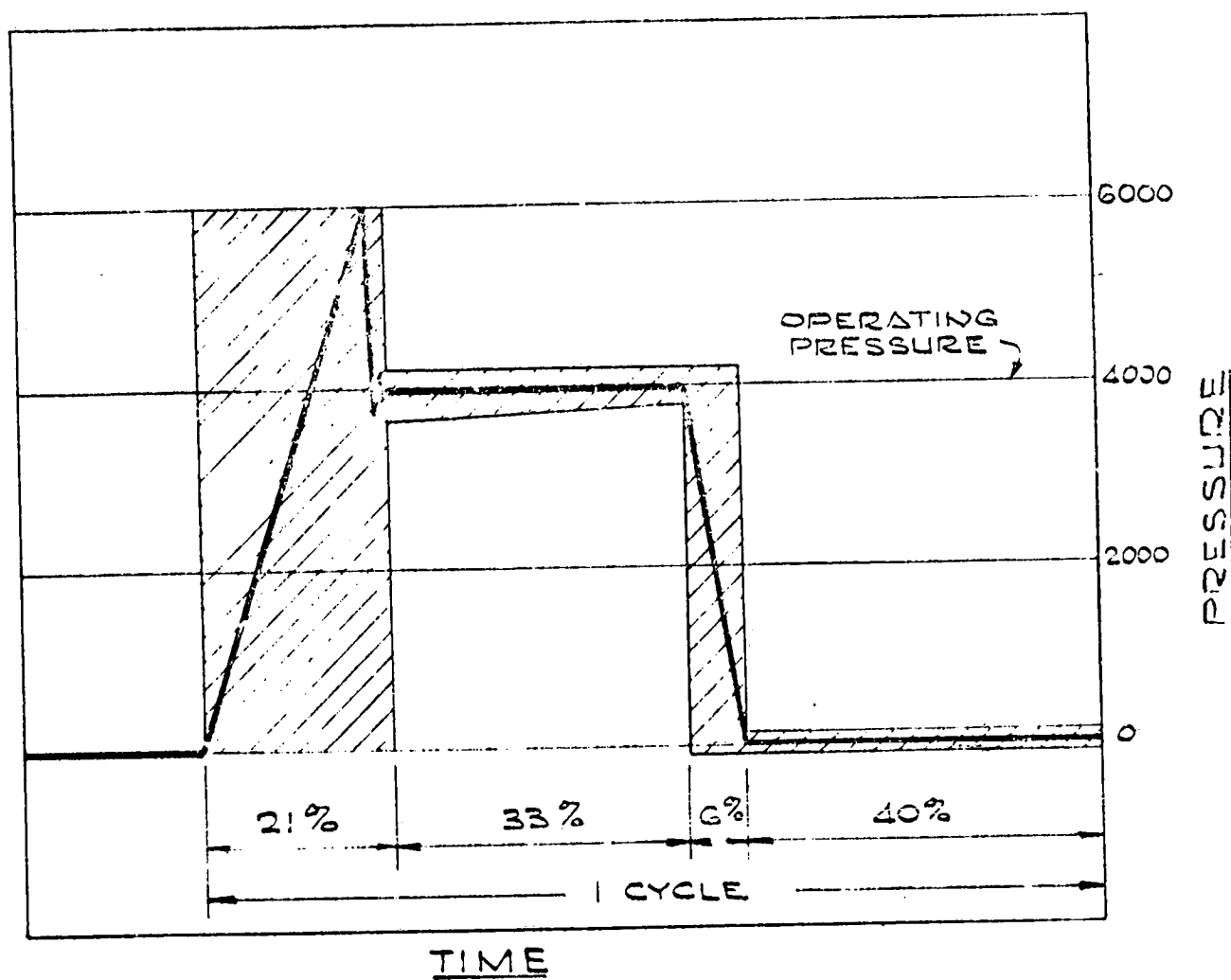

Cyclic Rate: 60-cycles per minute
Pressurization Rate: 192,000 psi per minute

FIGURE 4 PRESSURE VS TIME CURVE IMPULSE TEST

For a possible measurement of the degree of deterioration in the impulse tested specimen, it was decided that a Gaseous Leakage Test (Procedure 9) before and after the impulse cycling would be a more sensitive method than the Proof Pressure Tests called for in Mil-18280C. This test with helium is easily performed in the test facility without having to remove the specimen from their mounting fixture.

The test facility as schematically described in Figure 5 consisted of a compact arrangement of a high volume (10,000 psi rated) pressure pump, accumulators, hydraulic to hydraulic intensifier, directional control valve, cyclic timer, pressure switch, and associated piping. The pressure pulse was initially adjusted and thereafter periodically checked during the test by monitoring the photographic trace of an oscilloscope which interpreted the signals of the pressure transducer positioned in the test manifold.

Performance Evaluation Test No. 5

IMPULSE
(Reference: MIL-F-18280C)A. TEST PARAMETERS

1. Pressure: Nominal operating pressure of the Class of assemblies undergoing test with periodic pressure impulses to between 1.43 and 1.57 times nominal operating pressure.
2. Temperature
 - 2.1 Class I assemblies: From $-65^{\circ}\text{F} \pm 10^{\circ}\text{F}$ to $+450^{\circ}\text{F} \pm 25^{\circ}\text{F}$. For 75% of the total test time, chamber environment to be higher temperature, 450°F .
 - 2.2 Class II assemblies: From $-65^{\circ}\text{F} \pm 10^{\circ}\text{F}$ to $+275^{\circ}\text{F} \pm 25^{\circ}\text{F}$. For 75% of the total test time, chamber environment to be at higher temperature, 275°F .
3. Number of Impulse Cycles: 250,000
4. Impulse Cyclic Rate: 65 ± 5 cpm
5. Test Medium: Mobile Jet Oil II or equivalent

B. TEST APPARATUS

1. Impulse chamber
2. Specimen mounting fixture
3. Hydraulic pressure system (Input: 2,000 psig; 11 gpm, Output: 6,000 psig minimum)
4. Bourdon-type pressure gage (0-10,000 psig)
5. Manifold pressure control system
6. Oscilloscope
7. Chamber temperature control system

IMPULSE (Cont'd)

8. Pressure and temperature strip chart recorder
9. Calibration equipment (as required for pressure and temperature instrumentation)

C. TEST PROCEDURES

1. Install specimen in impulse mounting fixture
2. Install specimen mounting fixture in chamber
3. Purge specimens and applicable portions of manifold and pressure system with nitrogen if necessary
4. Attach helium source to the inlet fitting of specimen to be tested. Do not pressurize
5. Condition specimens for a minimum of one-hour at the elevated temperature for the class of fitting undergoing test
6. Install isolation tubes around each specimen
7. Insert leak detector sniffer probe through isolation tube near the fitting set. Record zero leak detector reading at zero
8. Pressurize each specimen in turn with helium to 3,000 or 4,000 psig depending on class of fitting and hold for two minutes. Record leak detector reading.
9. Reduce helium pressure to zero; remove isolation tubes and fill specimens, pump reservoir and all interconnecting fluid lines with the specified pressurizing fluid (Item A.5)
10. Bleed gas from entire pressurized assembly by venting the highest point of the system to atmosphere
11. Start temperature recording equipment and test chamber heating system
12. Condition specimens for a minimum of one-hour at the elevated temperature for the class of fitting undergoing test

IMPULSE (Cont'd).

13. Begin impulse-cycling system with pulse rate of 60 cycles/minute. Monitor pressure cycles on the oscilloscope initially, and at regular intervals (after 9,000, 99,000, 160,000 and 240,000 cycles) thereafter to insure for proper high and low pressure parameters
14. Initiate program of temperature cycles in accordance with the following schedule:

<u>Temperature Elevation*</u>	<u>Accumulated Time (hours)</u>	<u>Approximate Total Number Cycles</u>
High	0 - 1	3,600
Cycle (high to <u>low</u> to high)	1 - 4	14,400
High	4 - 15	54,000
Cycle (high to low to high)	15 - 18	64,300
High	18 - 29	104,400
Cycle (high to low to high)	29 - 32	115,200
High	32 - 43	154,800
Cycle (high to low to high)	43 - 46	165,600
High	46 - 57	205,200
Cycle (high to low to high)	57 - 60	216,000
High	60 - 69.44	250,000

*High temperature is either 450°F or 275°F depending on the Class of assembly under test; low temperature is -65°F ±10°F for either Class.

15. Loss of pressure in any one specimen will automatically stop the impulse-machine. When this occurs, record the number of cycles completed, total accumulated time under test and apparent reason for failure. Isolate the failed specimen and reactivate machine. (Note: Temperature cycles must be adjusted to maintain a 3:1 ratio of time at high:low temperature)
16. Upon completion of 250,000 impulse cycles, shut off the impulse machine and reduce temperature
17. Drain all oil from tested specimens by opening appropriate valve on manifold, and blowing nitrogen through top end of each specimen from which end caps were removed.

IMPULSE (Cont'd)

18. Replace end caps and conduct second gaseous leakage test according to instructions 3 through 9 .
19. Reduce chamber temperature to room temperature and remove fittings. For separable fittings, include a visual examination of the seals and sealing surfaces.

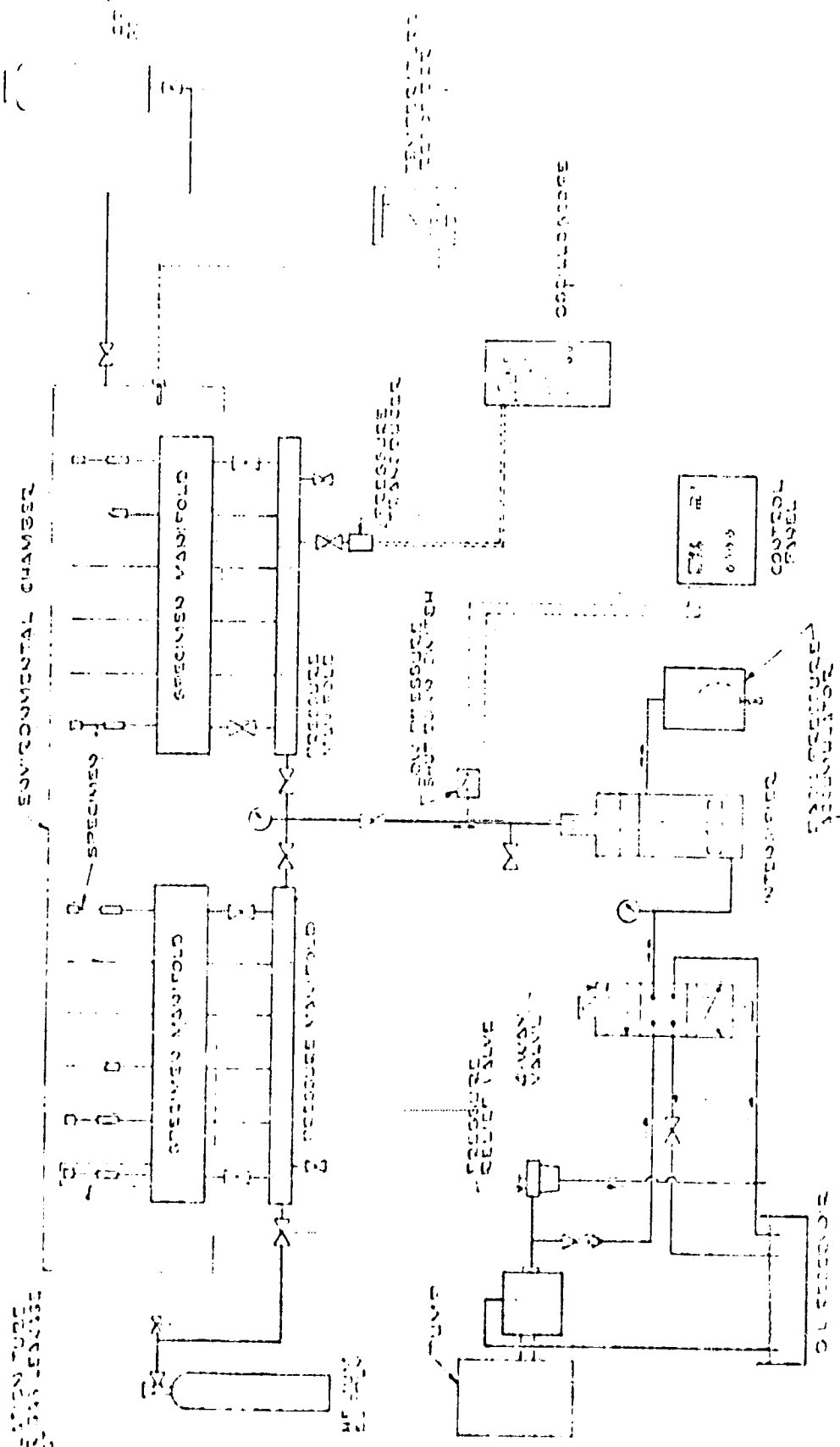

FIGURE 5 IMPULSE TEST FACILITY

ORIGINAL PAGE IS OF POOR QUALITY

SOUTHWEST RESEARCH INSTITUTE DATA SHEET

SUBJECT TEST SEQUENCE NO. VI
IMPULSE TEST

SHEET NO. 1 OF 2 SHEETS
PROJECT 01 3111 92
DATE _____
BY _____

TEST GROUP: _____

TEST TEMPERATURE (°F): _____

PEAK IMPULSE PRESSURE (psig) _____

OPERATING PRESSURE (psig) _____

PRESSURE RISE RATE (psig/sec) _____

GAS LEAKAGE RATE

CALCULATION BASE: _____ $\frac{\text{scg/sec}}{\text{scale}}$

(2 minute time interval)

TEST RESULTS

Specimen Code No. & Position No.	GAS LEAKAGE TESTS				Total No. Impulse Cycles	Failure Description
	Scale Before	Calculated Before	Scale After	Calculated After		

SOUTHWEST RESEARCH INSTITUTE
DATA SHEET

SUBJECT TEST SEQUENCE NO. VI
IMPULSE TEST LOG

75

SHEET NO. 2 OF 3 SHEETS
PROJECT 03-3113-02
DATE _____
BY _____

CYCLIC RATE PICTURES

RECORD (check when taken) Begin 9000 99,000 160,000 240,000
cycles

PROJECTED TEMPERATURE CYCLES

	HIGH	LOW	HIGH	LOW	HIGH	LOW	HIGH	LOW	HIGH	LOW	HIGH
DATE											
Start Time											
stop											
Accumulated Hours	1	4	15	18	29	32	43	46	57	60	69.44
No. of Cycles	3600	14,400	54,000	64,300	101,400	115,200	154,800	166,000	255,200	276,000	330,000

ADJUSTED TEMPERATURE CYCLES

	HIGH	LOW	HIGH	LOW	HIGH	LOW	HIGH	LOW	HIGH	LOW	HIGH
DATE											
Start Time											
stop											
Accumulated Hours											
No. of Cycles											

ACTUAL TEMPERATURE CYCLES

	HIGH	LOW	HIGH	LOW	HIGH	LOW	HIGH	LOW	HIGH	LOW	HIGH
DATE											
Start Time											
stop											
Accumulated Hours											
No. of Cycles											

SUPPLEMENT NO. 1

to

IMPULSE TEST PROCEDURE
for the
TESTING OF BOSS TYPE SEPARABLE
FITTING ASSEMBLIES

IMPULSE TEST
for
BOSS TYPE SEPARABLE FITTING ASSEMBLIES -
(Reference: Test Procedure for Unions)

A. TEST PARAMETERS

Same

B. TEST APPARATUS

Same but add Items 10 and 11 as follows:

10. Adapter: Vendors boss recess to 3/4" pipe (see Fig. 1a).
11. Extension adapter for manifold to place the boss and boss adapter in the controlled environmental chamber (see Fig. 1a).

C. TEST PROCEDURES

Add Item 1a to read as follows:

- 1a For boss assemblies, install as follows:
 - Install extension adapter in manifold.
 - Install vendors boss adapter in end of extension.
 - Install boss in recess (provided in the adapter) in accordance with vendors instructions and tools.

D. TEST RECORDS

Same.

6. ASSEMBLY TORQUE AND MISALIGNMENT TEST

Since these two tests were somewhat similar with respect to the mounting fixture required for each test specimen, they were combined into one test procedure. The tests are conducted only on the separable type fittings due to the nature of the tests. The test data is primarily for design purposes, but are also useful to the mechanic assembling the fitting.

The purpose of the Assembly Torque Test is to determine the amount of residual torque imposed on the tubing after the fitting has been assembled. This residual torque results from the frictional forces created between the contact surfaces of the mating parts while being joined together, and also retained after having been assembled. Properly positioned strain gages (see Procedure) and a mounting fixture that securely grips the test specimen, are the key to deriving worthwhile data from this test. Length of the tubing between the grip on one end and the fitting to be tested on the other, also determines the amount of residual torque left in the finished tubing assembly, since the "spring back" forces are dependent on both the length and the torsional stiffness of the tube. This implies that for the sake of correlation, the specimen lengths and the strain gage locations should be the same on all tests in a particular series. It can also be assumed that additional testing on varying lengths of the same size and type of tubing could result in data that might predict the residual torque values in random untested lengths of tubing assemblies. Due to the economics of this test program, only one particular length of specimens will be tested in this series.

The purpose of the misalignment test is to determine how great an angular offset could be imposed on the separable fittings and still effect an assembly and satisfactory seal. Length of the tubing between the grips and pivot axis of the fitting joint is of vital importance in obtaining reliable data, since the shorter the tubing the less the bending deflection and therefore, the more accurate the angle at the fitting interface. Through preliminary testing the necessary lengths were determined for each size (shown in Fig. 6 of the test procedure) and were found to be proportional with each tubing O. D.

A failure in this test was determined by three different conditions:

- (1) Seal could not be established at maximum torque.
- (2) Threads would no longer engage because of excessive angle of displacement.
- (3) Threads were being stripped during make-up.

The test assembly is shown in Figure 7 followed by the data sheet form used to record the test results.

Performance Evaluation Test No. 6

ASSEMBLY TORQUE AND MISALIGNMENT TEST
(Separable Designs Only)A. TEST PARAMETERS

1. Torsional strain in tubing induced by assembled separable fitting
2. Relative allowable displacement of specimen ends
3. Fitting leakage at 300 ± 10 psi (MS fittings) or 400 ± 10 psi (all other fittings)

B. TEST APPARATUS

1. Specimen misalignment and assembly torque test fixture
2. Strain gages - 3 element 45° rectangular rosette
3. Strain indicator and recording instruments
4. Torque wrench
5. Pressurizing medium (300 and 400 ± 10 psi nitrogen)

C. TEST PROCEDURE

1. Mount two, 3 element 45° rectangular strain gage rosettes, Micro-Measurement Type EA-06-062RB-120 or equivalent, on specimen in manner as shown in Figure 6. Care must be taken to insure that the two rosettes are diametrically opposed and that the center gage grid axis parallels the specimen axis, thereby correctly positioning the 45° elements.
2. Loosely install the assembled specimen in the test fixture and make necessary connections to the strain indicator and recording equipment. Only the four 45° elements will be connected in the form of a full bridge as shown in Figure 6, to measure torsional strains on the tube.

ASSEMBLY TORQUE AND MISALIGNMENT (Cont'd)

3. Balance the bridge output to a zero reading on the strain indicator. Fasten the appropriate part of the test union first in the vise clamp which is subsequently fixed rigidly to the test fixture, and then tighten the arc guide - clamp block on the tube in such a manner that will maintain or return the torque strains to a balanced (zero) condition on the strain indicator.
4. Loosen the union nut (E), noting and recording the breakaway torque required to disassemble the union.
5. Reassemble the fitting, tightening the nut (E) to the maximum torque with a torque wrench, simultaneously recording the applied running and residual strains during the tightening process.
6. Repeat Steps 4 and 5 two more times for a total of three complete assemblies and disassemblies of the union during which strain measurements were taken.
7. Following the completion of the assembly torque test, prepare the specimen for the misalignment test by repositioning the union on the fixture so that the mating surface pivot center (see Fig. 6) coincides with the angular scale zero point. Clamp the hex portion of the union or male connector portion of the fitting assembly in the vise clamp. The short length tubing portion of the test specimen is then fastened in the fixed clamp. The opposite end of the specimen is fitted into the arc guide/clamp block which has been positioned in the appropriate guide slot designated for the particular sized tubing being tested. The clamp is tightened to a point which will allow transverse movement of the tube within the clamp, but restrict any lateral or up/down motion.
8. Attach pressure hose to the male connector on one end of the test specimen and pressurize with nitrogen to the required test pressure and check for leaks around the union connections. Reduce pressure to zero.
9. Loosen nut (E) completely and angularly displace moveable end 2° with the aid of the arc guide/clamp block assembly. Re-engage fitting nut if possible and torque to manufacturers recommended minimum torque. Pressurize to required test pressure (300 psi-MS fittings and 400 psi all other fittings) with nitrogen. Bubble check for leaks. If leak occurs, increase torque to maximum allowable torque, and if leak persists,

ASSEMBLY TORQUE AND MISALIGNMENT (Cont'd)

proceed to next step (10). If no leak occurs, proceed to Step 11. (Note: Before proceeding to either step 10 or 11, bubble check fluid must be removed from fitting to avoid lubricating the threads.)

10. If a seal cannot be made with the separable union, reduce the angular displacement to a 1° increment and repeat Step 6. If a seal cannot be made with the separable union at 1° misalignment, return the tube to zero misalignment and repeat Step 6. Record torque pressure, degrees misalignment and leakage.
11. If the fitting does not leak at 2°, then increase the angular displacement in 1° increments and repeat Step 6 until a seal or connection cannot be made. Record torque, pressure and degrees misalignment.
12. Turn off air supply and remove specimen from fixture. Inspect visually and record results.

D. TEST RECORDS

Record all pertinent results on the test log, and calculate torsional stresses using the formula:

$$\sigma_T = \frac{\epsilon E}{1 + \mu}$$

where

σ_T = torsional stress
 ϵ = torsional strain (bridge output)
 E = modulus of elasticity
 μ = Poisson's Ratio

Residual Torque T_R will be calculated by using:

$$T_R = \frac{\sigma_T J}{r}$$

where

T_R = Residual Torque, in. lbs
 J = Polar moment of inertia, in.⁴
 r = distance from neutral axis to outer fiber, in.

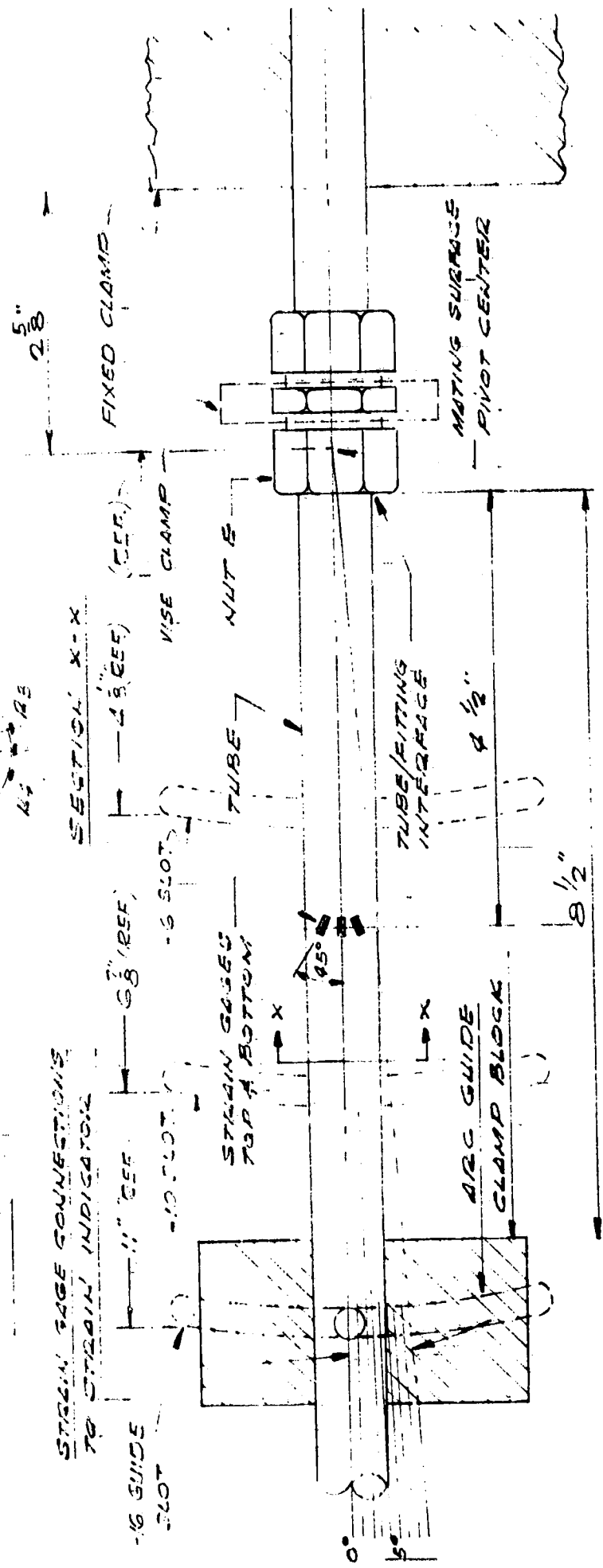
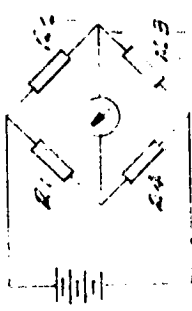

NOTE: STRAIN GAGE ROSETTES ARE POSITIONED BACK TO BACK AND ORIENTED THE SAME WITH RESPECT TO 45° ELEMENTS.

FIGURE 6 TEST FIXTURE AND STRAIN GAGE LOCATION

ORIGINAL PAGE IS OF POOR QUALITY

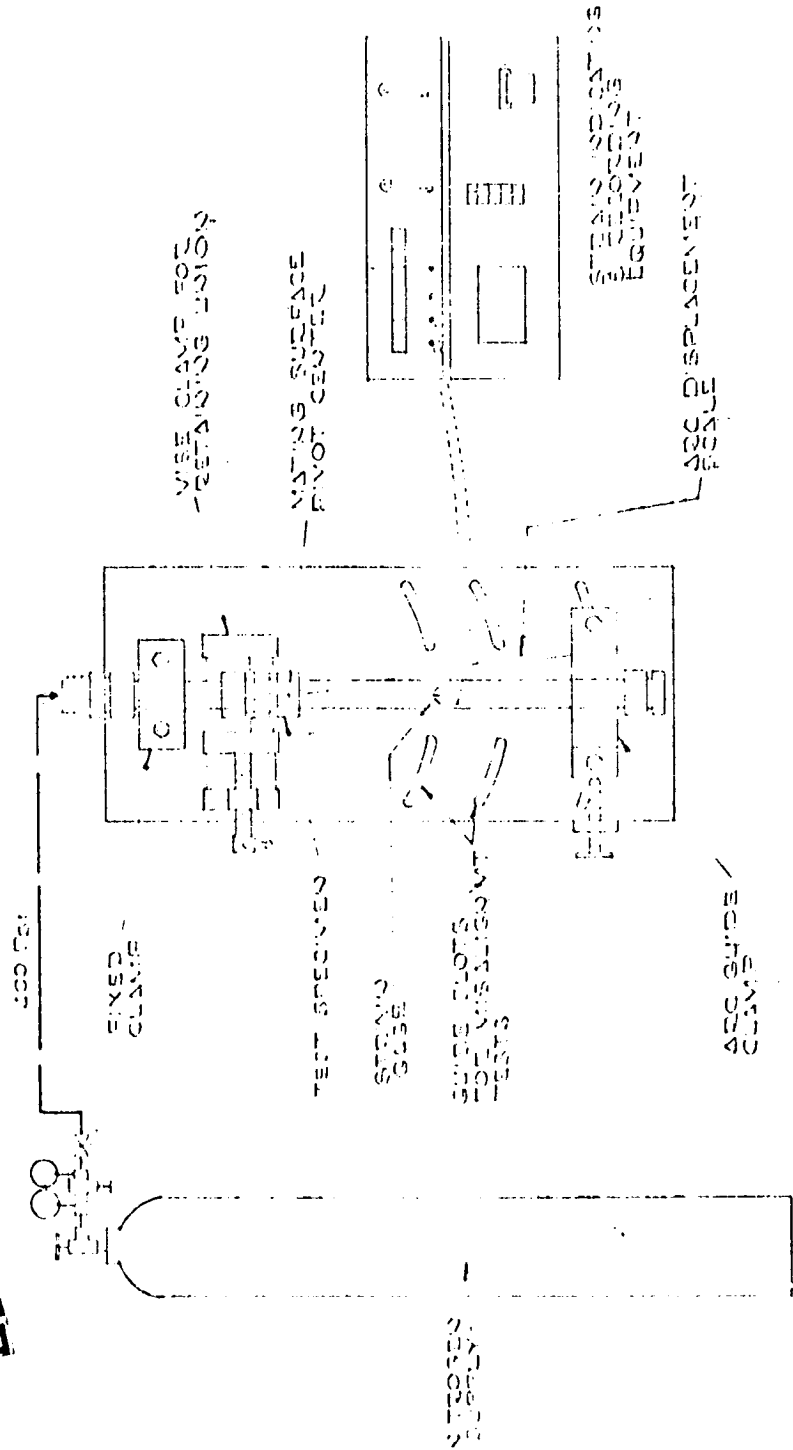

FIGURE 7 ASSEMBLY TORQUE-MISALIGNMENT TEST FACILITY

ORIGINAL PAGE IS
OF POOR QUALITY

SOUTHWEST RESEARCH INSTITUTE DATA SHEET

SHEET NO. _____ OF _____ SHEETS
 PROJECT 03-3113-002
 DATE _____
 BY _____

SUBJECT Test Sequence VII
Misalignment

Specimen Code No. : _____
 Test Pressure (psig): _____
 Test Temperature (°F): _____

Maximum Torque: _____
 Minimum Torque: _____
 Strain Gage Locations: _____
 (Distance from Edge of Fitting to Gage)

ASSEMBLY TORQUE TEST RESULTS

	<u>CYCLE 1</u>		<u>CYCLE 2</u>		<u>CYCLE 3</u>	
	<u>Bridge</u>	<u>Breakaway</u>	<u>Bridge</u>	<u>Breakaway</u>	<u>Bridge</u>	<u>Breakaway</u>
	<u>Output</u>	<u>Torque</u>	<u>Output</u>	<u>Torque</u>	<u>Output</u>	<u>Torque</u>
@ Start:	_____	_____	_____	_____	_____	_____
Tightened:	_____	_____	_____	_____	_____	_____
Total Reading:	① _____	② _____	③ _____	④ _____	⑤ _____	⑥ _____

Average Bridge Output Reading $\left(\frac{1 + 3 + 5}{3} \right) =$ _____ ⑦

Actual Torque Strain μ in/in $\left(\frac{⑦}{4} \right) =$ _____ ⑧

True Torsional Stress $\left(\sigma = \frac{\epsilon E}{1 + \mu} = \frac{⑧ E}{1.3} \right) =$ _____ ⑨
 (E 21-6-9 = 30×10^6 E_{Titanium} = 17×10^6)

REMARKS:

	<u>MISALIGNMENT TEST RESULTS</u>						
	<u>Zero</u>	<u>1st</u>	<u>2nd</u>	<u>3rd</u>	<u>4th</u>	<u>5th</u>	<u>6th</u>
Attempts:	_____	_____	_____	_____	_____	_____	_____
Angular Displacement (Degrees)	_____	_____	_____	_____	_____	_____	_____
Seal Established: (Yes - No)	_____	_____	_____	_____	_____	_____	_____

SUPPLEMENT NO. 1

to _____

ASSEMBLY TORQUE AND MISALIGNMENT TEST PROCEDURES
for the
TESTING OF BOSS TYPE SEPARABLE
FITTING ASSEMBLIES

ASSEMBLY TORQUE AND MISALIGNMENT
for
BOSS TYPE SEPARABLE FITTING ASSEMBLIES
(Reference: Test Procedure for Unions)

A. TEST PARAMETERS

Same

B. TEST APPARATUS

Same plus Items 6 and 7 as follows:

6. Adapter: Vendors boss recess to 3/4" pipe (see Fig. 6a).
7. Extension adapter for manifold to place the boss and boss adapter in the controlled environmental chamber (see Fig. 6a).

C. TEST PROCEDURE

1. Mount two, 3 element 45° rectangular strain gage rosettes, Micro-Measurement Type EA-06-062RB-120 or equivalent, on specimen in manner as shown in Figure 6a. Care must be taken to insure that the two rosettes are diametrically opposed and that the center gage grid axis parallels the specimen axis, thereby correctly positioning the 45° elements.
2. Loosely install the assembled specimen in the test fixture and make necessary connections to the strain indicator and recording equipment. Only the four 45° elements will be connected in the form of a full bridge as shown in Figure 6a, to measure torsional strains on the tube.
3. Balance the bridge output to a zero reading on the strain indicator. Fasten the appropriate part of the test fitting (the adapter) first in the vise clamp which is subsequently fixed rigidly to the test fixture, and then tighten the arc guide - clamp block on the tube in such a manner that will maintain or return the torque strains to a balanced (zero) condition on the strain indicator (see Figs. 6a).
4. Loosen the union nut (E), noting and recording the breakaway torque required to disassemble the fitting (see Figs. 6a).
5. Reassemble the fitting, tightening the nut (E) to the maximum torque with a torque wrench, simultaneously recording the applied running and residual strains during the tightening process (see Figs. 6a).

ASSEMBLY TORQUE AND MISALIGNMENT (Cont'd)

6. Repeat Steps 4 and 5 two more times for a total of three complete assemblies and disassemblies of the fitting during which strain measurements were taken.
7. Following the completion of the assembly torque test, prepare the specimen for the misalignment test by repositioning the fitting/tubing assembly on the fixture so that the fitting to boss mating surface pivot center (see Fig. 6a) coincides with the angular scale zero point. Clamp the hex portion of the adapter or male connector portion of the fitting assembly in the vise clamp. The extension/adapter portion of the test specimen is then fastened in the fixed clamp. The opposite end of the specimen is fitted into the arc guide/clamp block which has been positioned in the appropriate guide slot designated for the particular sized tubing being tested. The clamp is tightened to a point which will allow transverse movement of the tube within the clamp, but restrict any lateral or up/down motion.
8. Attach pressure hose to the male connector on one end of the test specimen and pressurize with nitrogen to the required test pressure and check for leaks around the union connections. Reduce pressure to zero (see Fig. 6a).
9. Loosen nut (E) completely and angularly displace movable end 2° with the aid of the arc guide/clamp block assembly. Re-engage fitting nut if possible and torque to manufacturers recommended minimum torque. Pressurize to required test pressure (300 psi MS fittings and 400 psi all other fittings) with nitrogen. Bubble check for leaks. If leak occurs, increase torque to maximum allowable torque, and if leak persists, proceed to next step (10). If no leak occurs, proceed to Step 11. (Note: Before proceeding to either Step 10 or 11, bubble check fluid must be removed from fitting to avoid lubricating the threads.)
10. If a seal cannot be made with the separable portion of the fitting, reduce the angular displacement to a 1° increment and repeat Step 6. If a seal cannot be made with the separable portion of the fitting at 1° misalignment, return the tube to zero misalignment and repeat Step 6. Record torque pressure, degrees misalignment and leakage.
11. If the fitting does not leak at 2° , then increase the angular displacement in 1° increments and repeat Step 6 until a seal or connection cannot be made. Record torque, pressure and degrees misalignment.

ASSEMBLY TORQUE AND MISALIGNMENT (Cont'd)

12. Turn off air supply and remove specimen from fixture. Inspect visually and record results.

D. TEST RECORDS

Same.

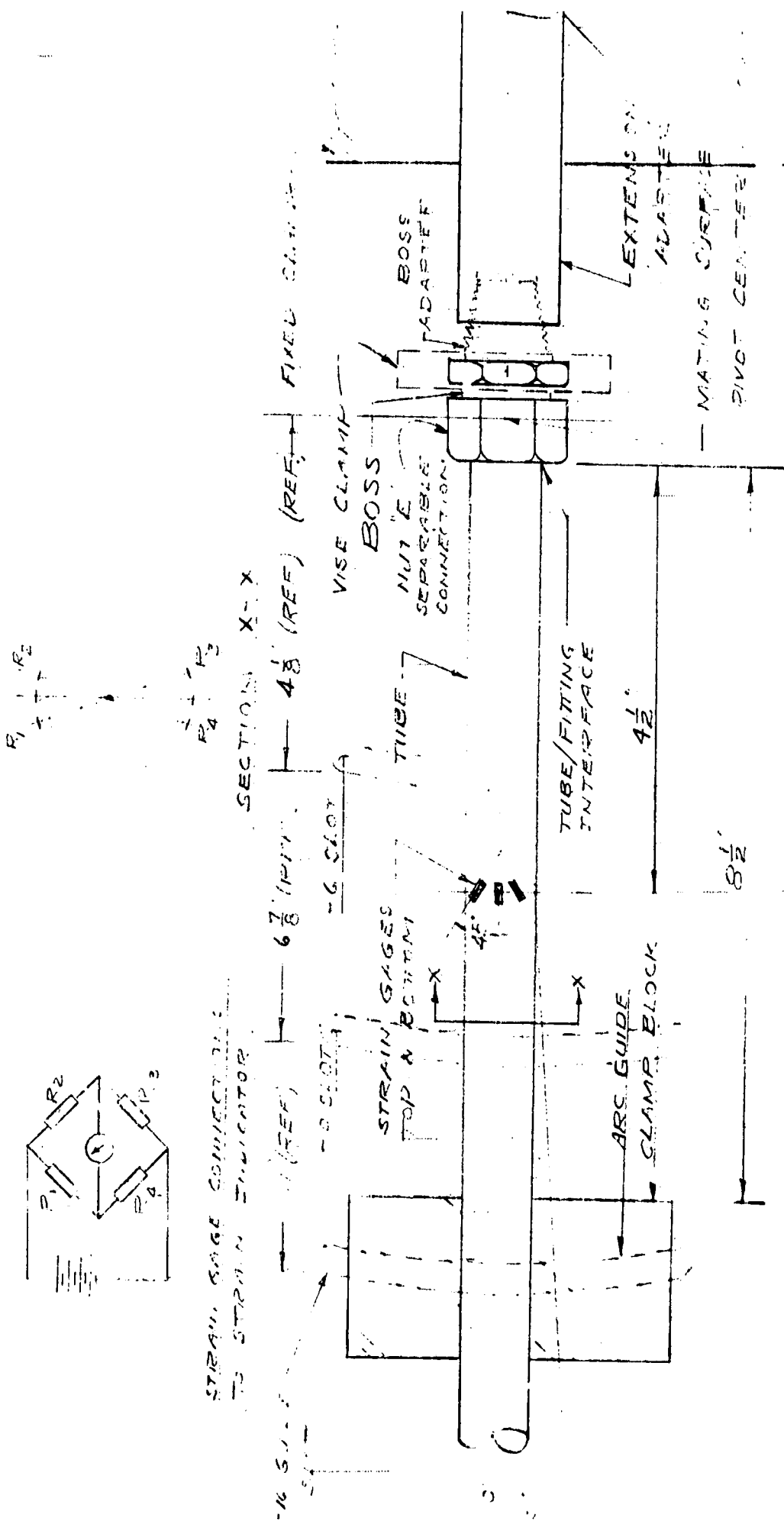

NOTE: STRAIN GAGE ROSETTES ARE POSITIONED BACK TO BACK AND ORIENTED THE SAME WITH RESPECT TO 45° ELEMENTS

FIGURE 6a TEST FIXTURE AND STRAIN GAGE LOCATION FOR BOSSES

ORIGINAL PAGE IS OF POOR QUALITY

7. AXIAL PULL AND TUBE RESTRAINT TEST

The purpose of the axial pull test is to determine the tensile load required to fail the tubing or fitting assembly. Failure is defined as the point where a gas leak is detected by a bubble check during the actual loading of the test specimen which has been pressurized with shop air.

The tube restraint test is used to determine the ability of the separable fitting to effect a seal with a gap existing between the two fitting halves before assembly. The gap is increased from zero to the point that a seal cannot be effected or 85% of the yield strength load of the specimen has been attained or exceeded by torqueing the two halves together. Care must be taken to insure that the length of the specimen between the grips of the test machine is the same for all specimens to allow for correlative test data.

The tests are conducted in a Baldwin Test Machine capable of producing 200,000 lbs of tensile load, using other required equipment as illustrated in Figure 8. Special grips were designed to grip the tubing uniformly as well as positively, and close fitting rod inserts were positioned in the tubing to prevent collapse of the tubing walls at the higher loads required for 21-6-9 and titanium. Deflection gages were positioned at appropriate points on the specimen to determine the distance in the gap, and also any slippage that might influence the test data.

Performance Evaluation Test No. 7.

AXIAL PULL AND TUBE RESTRAINT
(Tube Restraint for Separable Designs Only)A. TEST PARAMETERS

1. Mechanical uniaxial tensile load
2. Pressure: 100 \pm 10 psig
3. Pressurizing fluid (shop air regulated to 100 \pm 10 psig)
4. Relative longitudinal controlled displacement to create fitting gap
5. Tubing/fitting stress limit

B. TEST APPARATUS

1. Specimen axial pull holding fixture
2. Universal test machine with strain pacer (Baldwin or equivalent)
3. Strain pacer
4. Hydraulic hand pump
5. Pressure gage (0-100 psig)
6. Torque wrenches

C. TEST PROCEDURE (Separable Fittings)

1. Calculate maximum load required to achieve 85% of tensile yield stress in tubing.
2. Install test specimen in axial-pull test fixture with union tightly assembled with nominal torque. Distance between grips should be 13 inches.
3. Loosen union and with the aid of a deflection indicator mounted across the union joint open gap in joint .015", one side only.

AXIAL PULL AND TUBE RESTRAINT (Cont'd)

4. Torque fitting to measured nominal torque. (Do not exceed the load equalling 85% of yield.) Record tension load reading in tensile test machine and readings of dial indicators positioned at each end of the test specimen to determine slippage within the grips.
5. Pressurize fitting to 100 psi and leak check to determine if fitting completed the seal.
6. If fitting satisfactorily completed the seal, increase gap .005" and repeat steps 3, 4 and 5.
7. Continue increasing gap until tube stress reaches 85% yield or seal cannot be effected. Record results.
8. If a seal cannot be effected in Step 5, then reduce gap to .010" and repeat steps 3, 4 and 5. If a seal is still impossible, reduce the gap to .005". Each time record test results noted in steps 3, 4 and 5.
9. Assemble union to maximum torque value.
10. Pressurize specimen to 100 psi \pm 10 psig using shop air.
11. Check critical areas for leakage.
12. Continue to increase load until either:
 - (a) Pressure reduction or bubble check indicates fitting leakage or,
 - (b) Specimen fracture occurs; record results.
13. Turn off air supply and relieve specimen load.
14. Remove specimen from test fixture and visually inspect.
15. Record all pertinent results on test log. _____

FOR PERMANENT FITTINGS

16. Compute tensile load required to achieve 85% of tensile yield in tubing.
17. Install assembly in axial pull test fixture in tensile test machine.
18. Repeat steps 10 through 15 above.

C-2

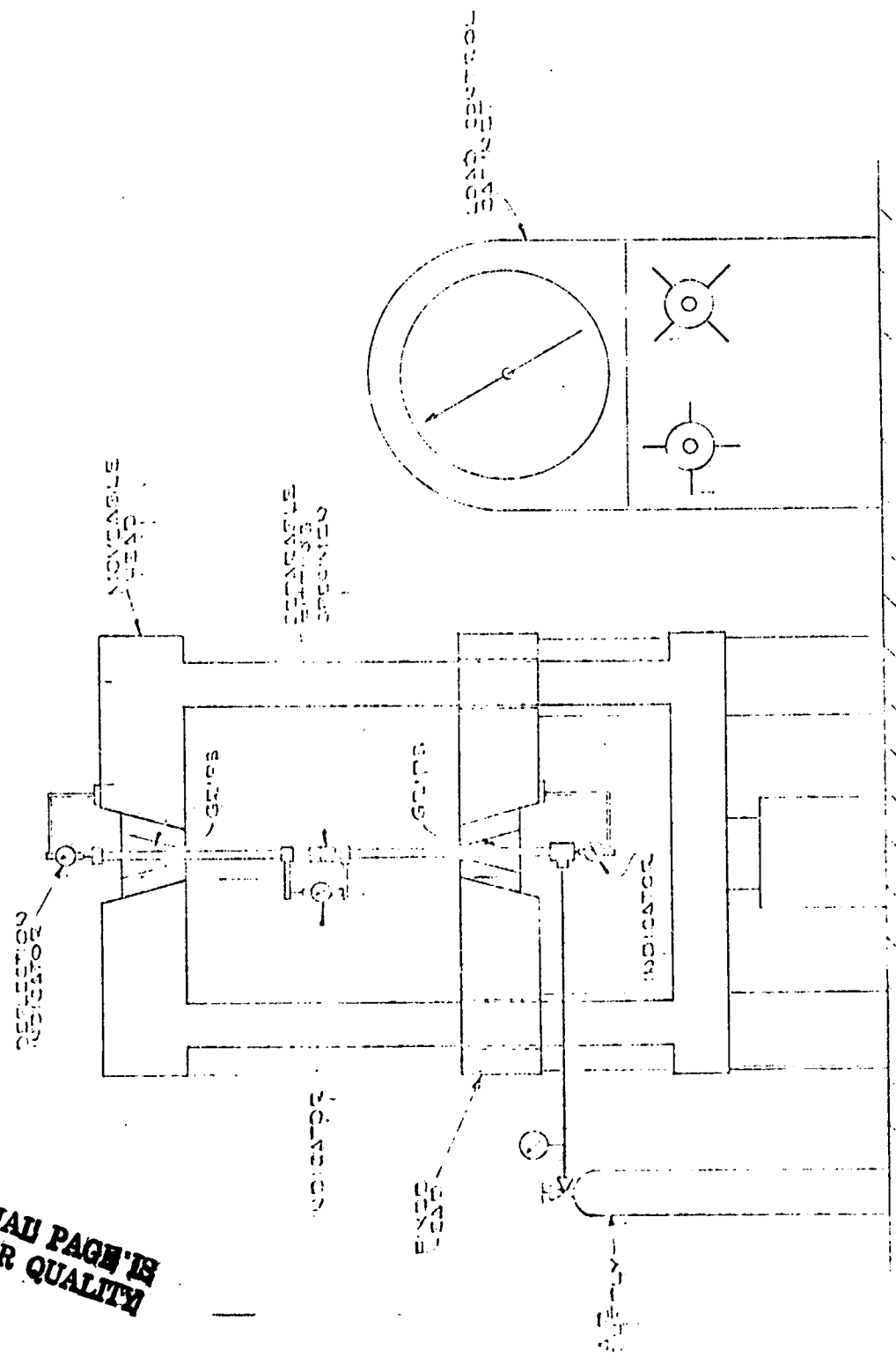

FIGURE 8 AXIAL PULL-TUBE RESTRAINT

ORIGINAL PAGE IS
OF POOR QUALITY

DATA SHEET

SUBJECT TEST SEQUENCE NO. IX
AXIAL PULL & TUBE RESTRAINT

PROJECT 03-3113-02
 DATE _____
 BY _____

SPECIMEN CODE NO. _____

NOMINAL TORQUE: _____

TEST TEMP. (F°) _____

MAX. TORQUE: _____

TEST AIR PRESS. (Psi) _____

85% TENSILE YIELD: _____ lbs.

START	LOADED	LOADED				
JOINT	TUBE	ACTUAL	TORQUE	TENSILE	AIR	
GAP	SLIPPAGE	GAP	(APPLIED)	LOAD	LEAK	
(DIAL "A")	(DIAL "B")	(DIAL "C")	["A" - (B + C)]	(Ft-in/lbs)	(lbs)	(Yes or No)

REMARKS:

AXIAL PULL TEST

Max. Torque Applied: _____

Max. Tensile Load at Failure: _____

Type of Failure: _____

Inspection Results: _____

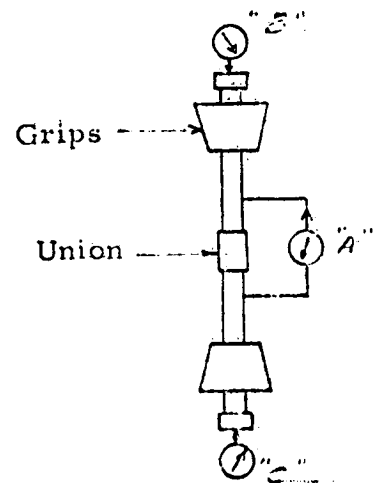

DIAL GAGE DIAG.

SUPPLEMENT NO. 1

to

AXIAL PULL AND TUBE RESTRAINT TEST PROCEDURE
for the
TESTING OF BOSS TYPE SEPARABLE
FITTING ASSEMBLIES

AXIAL PULL AND TUBE RESTRAINT TEST
for
BOSS TYPE SEPARABLE FITTING ASSEMBLIES
(Reference: Test Procedure for Unions)

A. TEST PARAMETERS

Same. —

B. TEST APPARATUS

Same plus Items 6 and 7 as follows:

6. Adapter: Vendors boss recess to 3/4" pipe (see Fig. 8a).
7. Extension adapter for manifold to place the boss and boss adapter in the controlled environmental chamber (see Fig. 8a).

C. TEST PROCEDURE

1. Calculate maximum load required to achieve 85% of tensile yield stress in tubing.
2. Install test specimen in axial-pull test fixture with boss and connecting tubing tightly assembled with nominal torque. Distance between grips should be 13 inches (see Fig. 8a).
3. Loosen fitting nut and with the aid of a deflection indicator mounted across the union joint open gap in joint .015", one side only.
4. Torque fitting to measured nominal torque. (Do not exceed the load equaling 85% of yield.) Record tension load reading in tensile test machine and readings of dial indicators positioned at each end of the test specimen to determine slippage within the grips.
5. Pressurize fitting to 100 psi and leak check to determine if fitting completed the seal.
6. If fitting satisfactorily completed the seal, increase gap .005" and repeat Steps 3, 4 and 5.
7. Continue increasing gap until tube stress reaches 85% yield or seal cannot be effected. Record results.
8. If a seal cannot be effected in Step 5, then reduce gap to .010" and repeat Steps 3, 4 and 5. — If a seal is still impossible, reduce the gap to .005". Each time record test results noted in Steps 3, 4 and 5.

AXIAL PULL AND TUBE RESTRAINT TEST (Cont'd)

9. Assemble boss to fitting using maximum torque value.
10. Pressurize specimen to 100 psi \pm 10 psig using shop air.
11. Check critical areas for leakage.
12. Continue to increase load until either:
 - (a) Pressure reduction or bubble check indicates fitting leakage or,
 - (b) Specimen fracture occurs; record results.
13. Turn off air supply and relieve specimen load.
14. Remove specimen from test fixture and visually inspect.
15. Remove boss from adapter and visually inspect.
16. Record all pertinent results on test log.

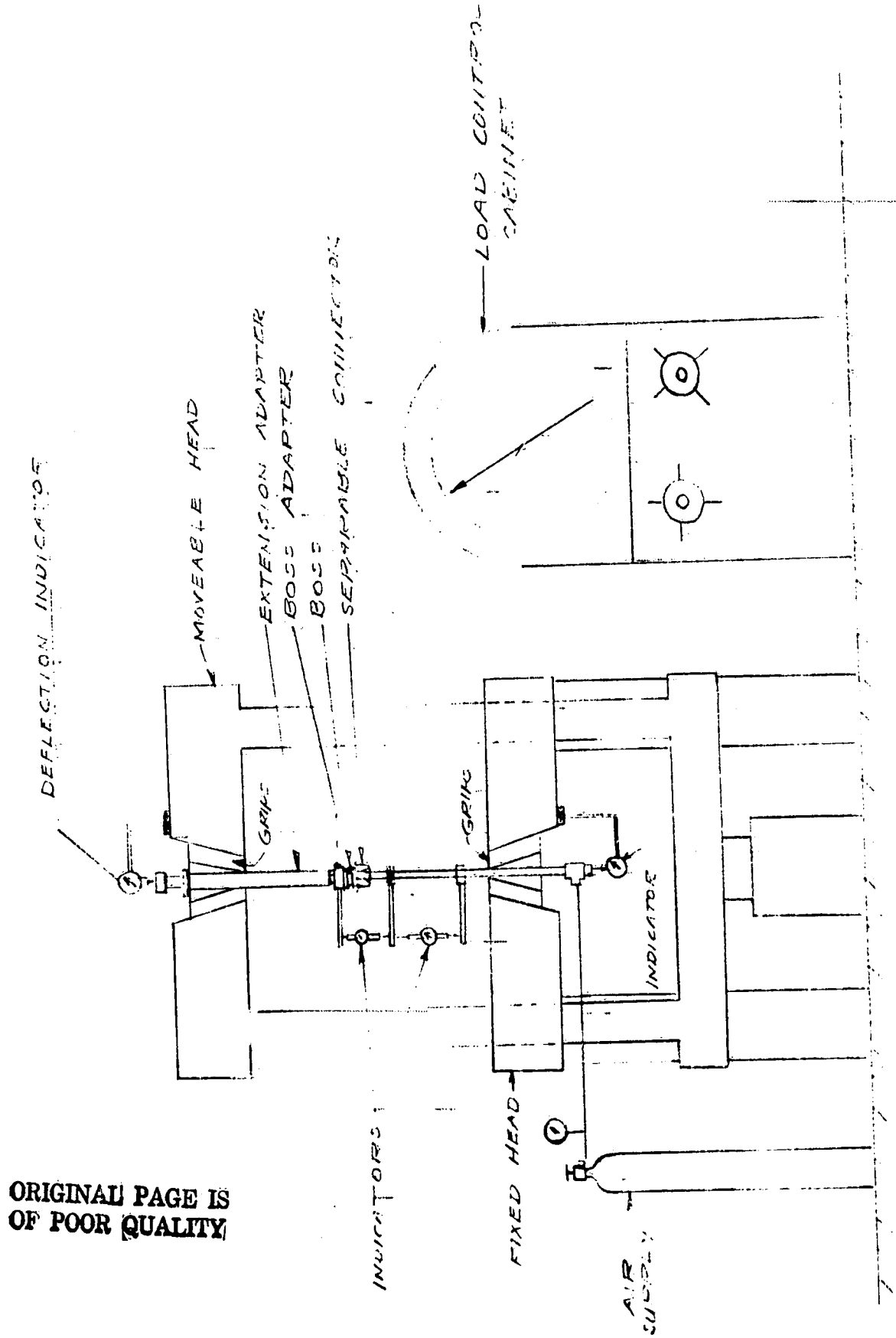

ORIGINAL PAGE IS
OF POOR QUALITY

FIGURE 8a AXIAL PULL-TUBE RESTRAINT FOR BOSS TEST

8. STRUCTURAL LOAD RELAXATION TEST (Separable Fitting Only)

The purpose of this test is to measure the structural load relaxation of a separable fitting assembly subjected to a tensile stress load equal to the stress level which would be applied to the tubing by proof pressure (2 times operating pressure) and to a temperature condition equal to the maximum allowable for the particular type of tubing. The relaxation is measured in terms of strain reduction monitored periodically during the test period of 100 hours, and subsequently converted into terms of stress reduction.

One uniaxial high temperature strain gage is mounted to the specimen to measure the tensile strain applied, and the specimen is positioned in a separate, self-contained load frame capable of rigidly gripping the tubing and simultaneously applying the prescribed tensile load. The entire assembly is then placed into an environmental chamber designed to withstand proof pressure level failures in the event of their occurrence.

In order to obtain definitive results from this test, it is of prime importance to "exercise" the strain gages mounted to each specimen by pressurizing and loading the specimen several times at elevated temperatures prior to the actual start of the test period. This is done to settle the strain gage and insure the satisfactory curing of the special adhesive used in the application of the gage. An illustrative diagram of the test fixture is presented in Figure 10 following the test procedure.

Performance Evaluation Test No. 8

STRUCTURAL LOAD RELAXATION
(Separable Fittings Only)A. TEST PARAMETERS

1. Test Pressures
 - 1.1 Class I or II assemblies: 200 ± 5 psig
 - 1.2 Class I assemblies: to 8,000 psig
 - 1.3 Class II assemblies: to 6,000 psig
2. Test Temperatures
 - 2.1 Class I assemblies: $450 \pm 25^\circ\text{F}$ or,
 - 2.2 Class II assemblies: $275 \pm 25^\circ\text{F}$
3. Test Load: As required to produce a tensile load on the specimen equivalent to that which would be induced by pressures twice the operating pressures.
4. Test Duration: 100 hours at elevated temperature
5. Test Medium: Mobiltherm 600 Oil or equivalent

B. TEST APPARATUS

1. Structural load relaxation (SLR) test chamber
2. SLR specimen load frame
3. Hydraulic pressure pump (10,000 psig; 5 gpm)
4. Bourdon-type pressure gage (0-10,000 psig)
5. Strain gage instrumentation
6. Calibration equipment (for pressure, temperature, and strain gage instrumentation)

STRUCTURAL LOAD RELAXATION (Cont'd)

C. TEST PROCEDURE

1. At location "A" on a SLR test specimen, see Figure 9, mount a single element strain gage, Micro-Measurements Type WK-09-062AU-120 or equivalent. The gage grid axis must parallel the specimen axis.
2. Install the specimen in a SLR load frame, and by applying a tensile load to the specimen of at least 75% of the test load, tighten the tube holding clamps to insure against slippage during the test.
3. Position the load frame in the SLR test chamber, connect the specimen strain gage lead wires to the strain indicating circuit, and the specimen itself to the pressurizing manifold.
4. Repeat steps 1-3 for all specimens in a particular test run.
5. Increase the SLR test chamber temperature to 5% above the amount required for the class of fitting undergoing test and maintain this temperature for two hours.
6. Reduce the temperature to the required test temperature and conduct a proof pressure test in accordance with the Test Procedure No. 2.
7. Upon successful completion of the Proof-Pressure Test apply the tensile load required for the test to each specimen, hold momentarily and then reduce the load to zero. Repeat this step for a total of three cycles, in order to settle the strain gage installation and reduce the hysteresis effect normally associated with this type of test. Reduce the temperatures and pressure to ambient, allow to stabilize, and then balance each strain gage to a null reading on the indicator and record the zero setting.
8. Raise the temperature in the test chamber to the required amount for the actual test, and determine when temperature has stabilized by periodic recording of strain gage output readings.
9. After temperature and strain gages have stabilized, record the strain readings of each gage and use this setting as the test zero.

STRUCTURAL LOAD RELAXATION. (Cont'd)

10. Pressurize the specimen to 200 psi, and load each specimen in turn to the predetermined tensile strain required by the test, using the test zero recorded in step 9 as the starting point. Record the date and time, together with the strain readings of all gages. This will initiate the 100-hour test period.
11. During the 100-hour test period, as a minimum, record strain gage readings at 0815 and 1615 hours each day. If during a visual inspection at these times a specimen leakage is detected, relieve the pressure and load on the leaking specimen and record pertinent data.
12. Upon completion of the 100-hour test, record the strains of all gages, and then increase the pressure to twice operating pressure for the class of fitting undergoing the test and hold at this pressure for 5 minutes. Visually inspect each specimen for signs of leakage, and record strain readings again.
13. After the 5 minute hold period reduce the pressure and tensile loads on each specimen to zero, and record the strains. This reading when compared with the initial test zero of step 9 will indicate a permanent set or a zero shift.
14. Reduce the test chamber temperature to ambient, record strains of all gages, and remove specimens from the load frames. After visual inspection of the test specimens, record all pertinent data on the test log.

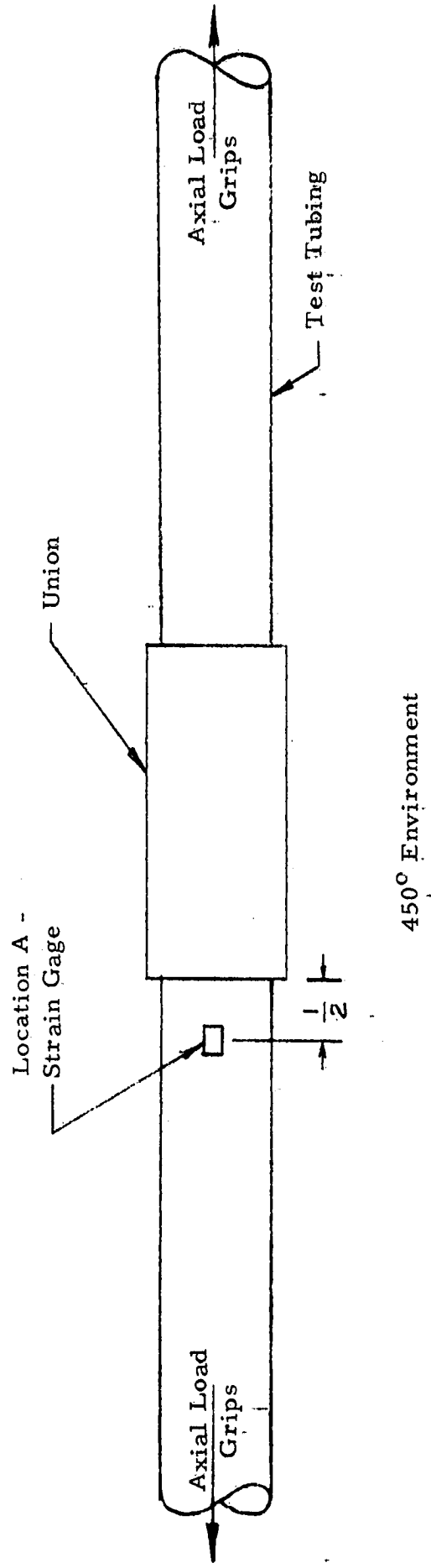

FIGURE 9 STRAIN GAGE LOCATION FOR STRUCTURAL LOAD RELAXATION TEST

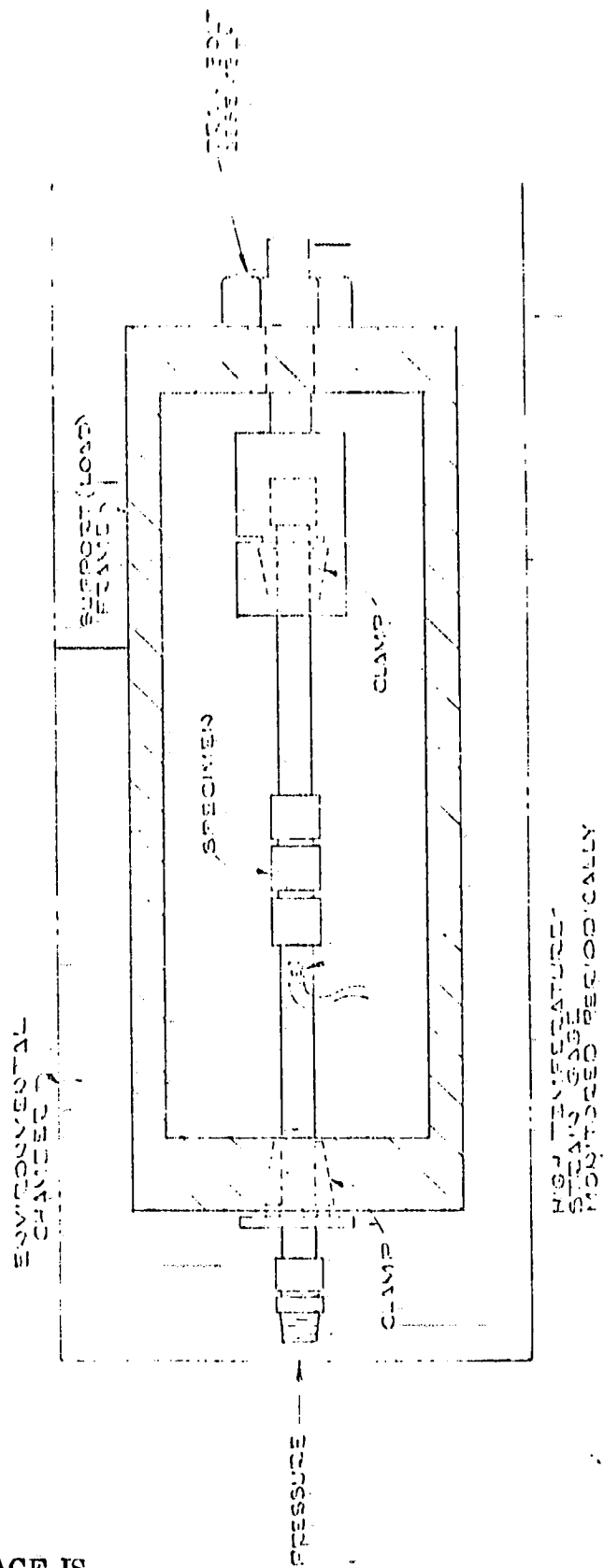

FIGURE 10 STRUCTURAL RELAXATION TEST FACILITY

ORIGINAL PAGE IS
OF POOR QUALITY

DATA SHEET

SUBJECT TEST SEQUENCE NO. XII
STRUCTURAL LOAD RELAXATION

SHEET NO. _____

PROJECT 03-3113-01

DATE _____

BY _____

SPECIMEN CODE NO. _____

TEST POSITION NO. _____

APPLIED TORQUE: _____
(Separable Fittings Only)

102

Test Temp. (°F): _____
Test Press. (Psi): _____

Test Stress: _____ psi (Req'd) _____ psi (actual)
Test Strain: _____ in/in (Req'd) _____ in/in (actual)

TEST STRAIN READINGS

Date	Time	Temp.	Strain Reading	Actual Strain
First Day		75°	@ 0 psi no load	
Fourth Day	8:15 A.M. 4:45 P.M.			

Date	Time	Temp.	Test Temp.	Test Temp.	Actual Strain
			@ 0 psi no load		
			@ 200 psi no load		
			@ 200 psi no load		
Fifth Day	8:15 P.M.			End of Test	

Date	Time	Temp.	Test Temp.	Test Temp.	Actual Strain
			@ 200 psi & load		
Second Day	8:15 A.M. 4:45 P.M.			@ Proof Press.	
				@ Temp. & Tensile Load	
				@ Temp. & no load	
				@ Rm, Temp. no load	

Date	Time	Temp.	Test Temp.	Test Temp.	Actual Strain
Third Day	8:15 A.M. 4:45 P.M.				

REMARKS:

SUPPLEMENT NO. 1

to

STRUCTURAL LOAD RELAXATION TEST PROCEDURE
for the
TESTING OF THE BOSS TYPE SEPARABLE
FITTING ASSEMBLIES

STRUCTURAL LOAD RELAXATION TEST
for
BOSS TYPE SEPARABLE FITTING ASSEMBLIES
(Reference: Test Procedure for Unions)

A. TEST PARAMETERS

Same

B. TEST APPARATUS

Same plus Items 7 and 8 as follows:

7. Adapter: Vendor's boss recess to 3/4" pipe (see Fig. 9a).
8. Extension adapter for manifold to place the boss and boss adapter in the controlled environmental chamber (see Fig. 9a).

C. TEST PROCEDURE

Same except for Items 1, 2 and 14 to read as follows.

1. At location 'A' on the SLR test specimen shown in Figure 9a, mount a single element strain gage, micro-measurements Type WK-09-062AU-120 or equivalent. The grid axis must be parallel to the specimen axis. Assemble the extension adapter and the boss adapter. Install the boss in the recess provided by the vendor in the boss adapter. Assemble the tube to the boss and install the end fittings.
2. Install the specimen in a SLR load frame in accordance with Figure 10a, and by applying a tensile load to the specimen of at least 75% of the test load, tighten the tube holding clamps to insure against slippage during the test.
14. Reduce the chamber temperature to ambient, record the strains of all gages, and remove the specimens from the load frames. After visual inspection of the total assembly, record all pertinent data on the test log. Disassemble the test specimen(s) and pay particular attention to the separable part of the fitting as well as the boss as it is removed from the adapter.

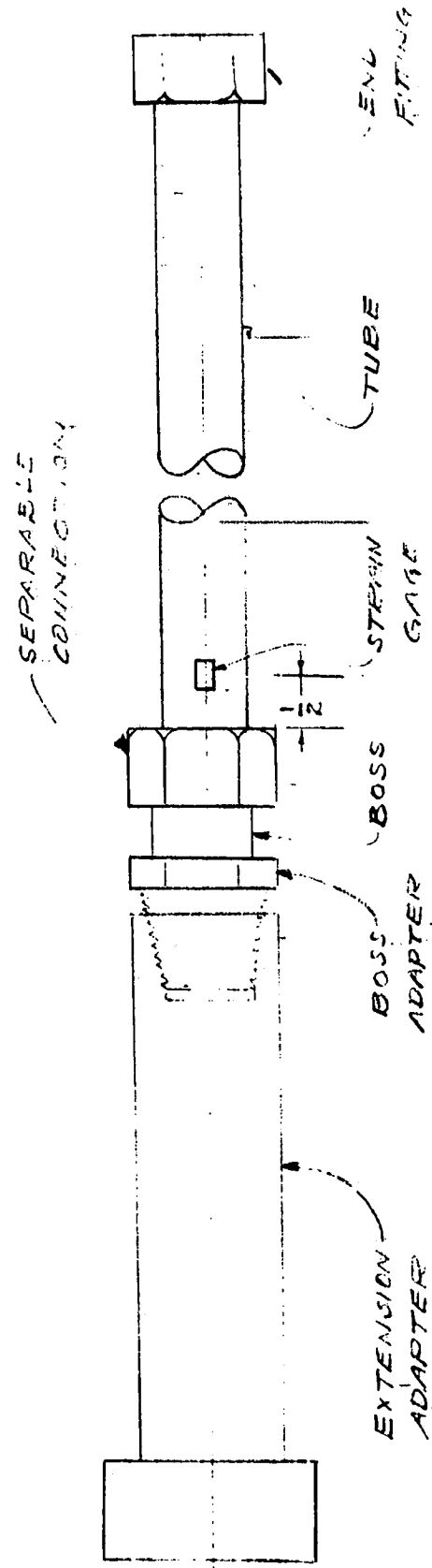
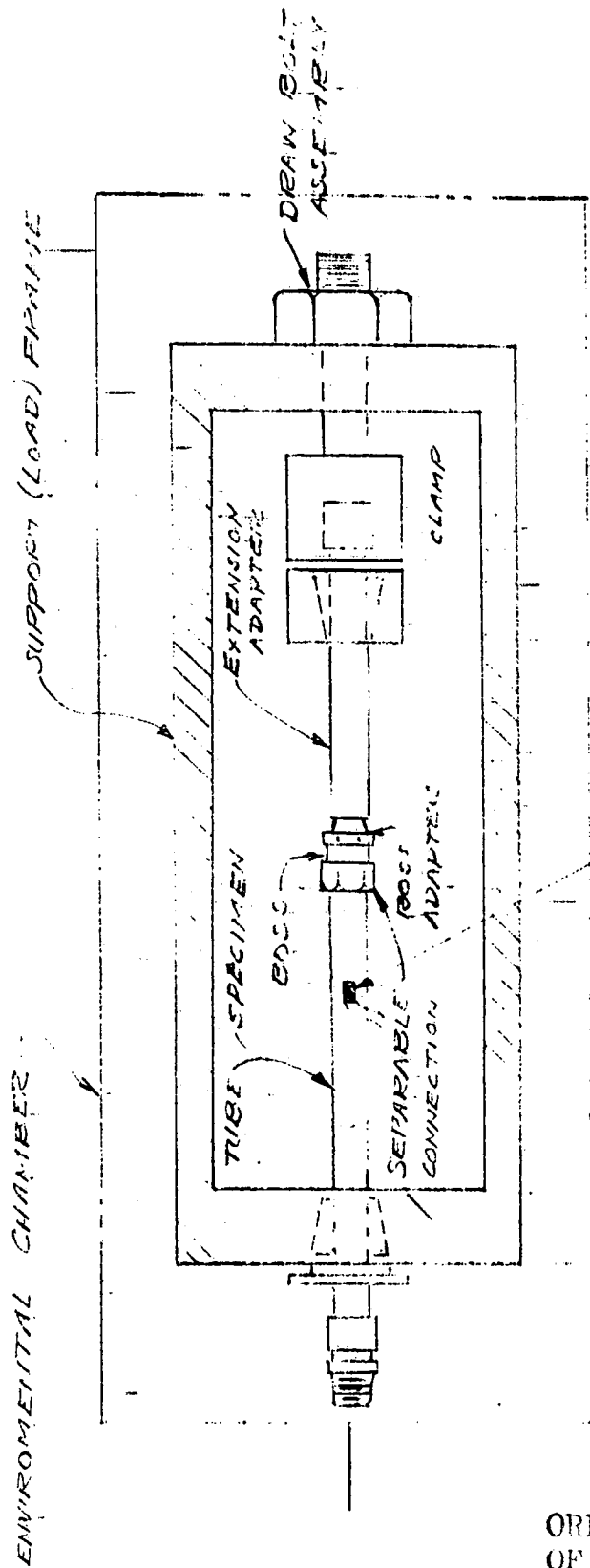

FIGURE 9a BOSS TEST SPECIMEN ASSEMBLY AND STRAIN GAGE LOCATION

ORIGINAL PAGE IS
OF POOR QUALITY



HIGH TEMPERATURE STRAIN -
GAGE, MONITORED PERIODICALLY

FIGURE 10a STRUCTURAL RELAXATION TEST FACILITY
FOR BOSS TEST

ORIGINAL PAGE IS
OF POOR QUALITY

9. GASEOUS LEAKAGE TEST

In this test program the gaseous leakage test is used primarily as a means to detect any deterioration in the integrity of a fitting being tested under some of the other test procedures. The very small molecular structure of helium gas, the tracer gas used in this test, allows it to penetrate through openings which other agents such as water and oil cannot penetrate. Therefore injection of pressurized helium into a test system together with a detection device capable of sensing very small amounts of escaping helium provided a more sensitive method to determine the extent of possible damage suffered by a test specimen. This method also makes it possible to determine a rate of leakage, whereas a simple bubble check as used in some tests in this program, or the water immersion type bubble check recommended by others does not.

A VEECO brand, mass spectrometer type Model 90AB helium leak detector together with its associated "sniffer" device, was used to conduct this type of test. A comparatively simple method was devised wherein a small isolation tube was placed over the test specimen mounted in the test manifold of the test facility being used, and with the aid of the "sniffer" device, readings were taken before and after helium gas was injected into the specimen. In this manner the amount of helium escaping from the test specimen into the isolation tube was measured over a defined period of time, and when compared with a known leakage rate into the same isolation tube during calibration, a definitive measurement of the leakage rate through the test

specimen could be established. For the purpose of this test program, "no leakage" is defined as a leakage rate of 1.0×10^{-3} scc/sec or less.

The normal test set-up is illustrated in Figure 1 following the Repeated Assembly Test Procedure. The test data is recorded on the test data sheets of the primary test being conducted on the specimen.

Performance Evaluation Test No. 9

GASEOUS LEAKAGE
(Reference: ARP 899)A. TEST PARAMETERS

1. Pressure
 - 1.1 Class I assemblies: $4,000 \pm 25$ psig.
 - 1.2 Class II assemblies: $3,000 \pm 25$ psig
2. Temperature
 - 2.1 Class I assemblies: $450^{\circ}\text{F} \pm 10^{\circ}\text{F}$ and room temp.
 - 2.2 Class II assemblies: $275^{\circ}\text{F} \pm 10^{\circ}\text{F}$ and room temp.
3. Pressure Hold Time: 2 minutes
4. Test Medium: Gaseous helium.

B. TEST APPARATUS

1. Veeco Model MS90AB Leak Detector or equivalent calibration equipment as required for above instruments
2. Gaseous pressure source (0-4,100 psig)
3. Bourdon-type-pressure gage (0-5,000 psig), temperature controller, temperature recorder
4. Specimen mounting fixture and isolation tube
5. Environmental chamber

C. TEST PROCEDURES

1. Install specimens in mounting fixture used in primary test
2. Install isolation tube over specimens
3. Purge specimens and applicable portions of manifold and pressure system with nitrogen

GASEOUS LEAKAGE (Cont'd)

4. Raise chamber temperature to desired level and hold for 20 minutes to allow for thermal stabilization.
5. Attach helium source to the inlet fitting of specimen to be tested. Do not pressurize.
6. Insert leak detector sniffer probe through isolation tube near the fitting set. Record zero leak detector reading at zero.
7. Pressurize specimen with helium to operating pressure for class of assembly being tested and hold for two minutes. Record leak detector reading every 30 seconds.
8. Reduce helium pressure to zero and record leak detector reading.

SUPPLEMENT NO. 1

to

GASEOUS LEAKAGE TEST PROCEDURE
for the
TESTING OF BOSS TYPE SEPARABLE
FITTING ASSEMBLIES

GASEOUS LEAKAGE TEST
for
BOSS TYPE SEPARABLE FITTING ASSEMBLIES .
(Reference: Test Procedure for Unions)

A. TEST PARAMETERS

Same.

B. TEST APPARATUS

Same plus Items 6 and 7 as follows:

6. Adapter: Vendors boss recess to 3/4" pipe (see Fig. 1a in Repeated Assembly Test Procedure).
7. Extension adapter for manifold to place the boss and the boss adapter in the controlled environmental chamber (see Fig. 1a in Proof Test Procedure).

C. TEST PROCEDURE

Same.

10. CLASS "A" FIRE RESISTANCE TEST

This test is intended to determine the fire resistance of tube fitting assemblies under simulated conditions that parallel those taking place in a severe aircraft power-plant fire.

Test parameters as outlined in ARP 1055, currently in the state of revision, were used in the performance of the test. Generally the equipment design and calibration procedures also described therein were followed. However, some modifications were necessary because of the new 4,000 psi pressurized system requirement at elevated temperatures of 200-230°F. This primarily involved installation of heat exchangers in the closed loop pressure system to protect the seals in the high volume pump and other control equipment. The oil was heated to the required temperature just upstream of the test specimen.

Another change from the ARP 1055 was the use of a methane (2,000°F) torch instead of the oil burner specified. This resulted in a much cleaner and simpler test, in addition to the fact that the particular type of oil burner called for is no longer available. Safety precautions included remotely controlled test actuators, a closed circuit TV monitoring system, and the installation of the test facilities in a fire/explosion proof cell. The test loop is shown in the descriptive layout of Figure 11 following the Test Procedure Outline.

Performance Evaluation Test No. 10

CLASS A FIRE RESISTANCE
(Reference: ARP 1055)A. TEST PARAMETERS

1. Test Pressures
 - 1.1 Class I assemblies: Between 4,000 and 4,025 psig.
 - 1.2 Class II assemblies: Between 3,000 and 3,025 psig
2. Test Temperatures
 - 2.1 Class I assemblies: 200-230°F (max. internal fluid temp), and exposure to a flame temperature of 2,000 \pm 100°F as measured 1/4-in. from specimen
3. Test Time: 5-minute exposure to flame
4. Flame Envelope: A minimum of one tube diameter upstream and downstream of the test fitting. Envelope to be symmetrical about the horizontal and vertical tube-fitting center planes and completely engulf the test fitting
5. Specimen Vibration: \pm 1/16-in. displacement of the test fitting @ 2,000 \pm 50 cpm

B. TEST APPARATUS

1. Flame chamber, including air flow regulating fan, methane burner (Clements Manufacturing Company Model M-2 or equivalent), with 4,500 BTU minimum heat output
2. Pressurizing fluid: Mobil Jet Oil II or equivalent
3. 55 gallon oil supply
4. Specimen fire resistance holding fixture and CO₂ extinguisher
5. Mechanical vibrator
6. Hydraulic pressure pump (5,000 psig; 1-1/2 gpm)

CLASS A FIRE RESISTANCE (Cont'd)

7. Input oil heater (1500 watts)
8. Heat exchanger (10,000 BTU's./minute)
9. Flow meter (0.05 to 1.5 gpm)
10. Bourdon-type pressure gage (0-5,000 psig)
11. Shielded thermocouple probe (2,500°F capability)
12. Temperature recorder and automatic shutoff system
13. Pressure transducer and strip chart recorder
14. Calibration equipment as required for above instruments

C. TEST PROCEDURES

1. Install specimen in fire resistance mounting fixture
2. Activate pressurizing fluid heating system, start the pressure pump and circulate the oil through the specimen. Visually inspect the system for leakage and begin monitoring the temperature at the inlet and outlet positions to the specimens with a recorder
3. After the fluid temperature attains the inlet operating temperature of 200 to 230°F, gradually increase the pressure to the required operating pressure and adjust the pump controls to assure the specified flow.*
4. Start specimen vibrating mechanism and turn on the methane burner. (Adjustment of the flame temperature to 2,000°F \pm 100°F as measured at a point 1/4 in. from specimen** must be accomplished prior to the actual test.)
5. Maintain flame for either five minutes or until leakage develops. Measure oil outlet temperature for temperature rise cross fitting

* In gallons per minute; numerically equal to square of tube I. D. in inches..

**Burner calibration conducted similar to that described in ARP 1055.

CLASS A FIRE RESISTANCE (Cont'd)

6. Reduce pressure to zero and shut off the pressure pump and vibrator*
7. Allow the specimen to cool; remove from holding fixture
8. Conduct visual inspection. For tests of separable fittings, include examination of seals and sealing surfaces

*Test cell is equipped with a CO₂ fire extinguishing system; if leakage occurs, flame will be extinguished and oil flow will cease.

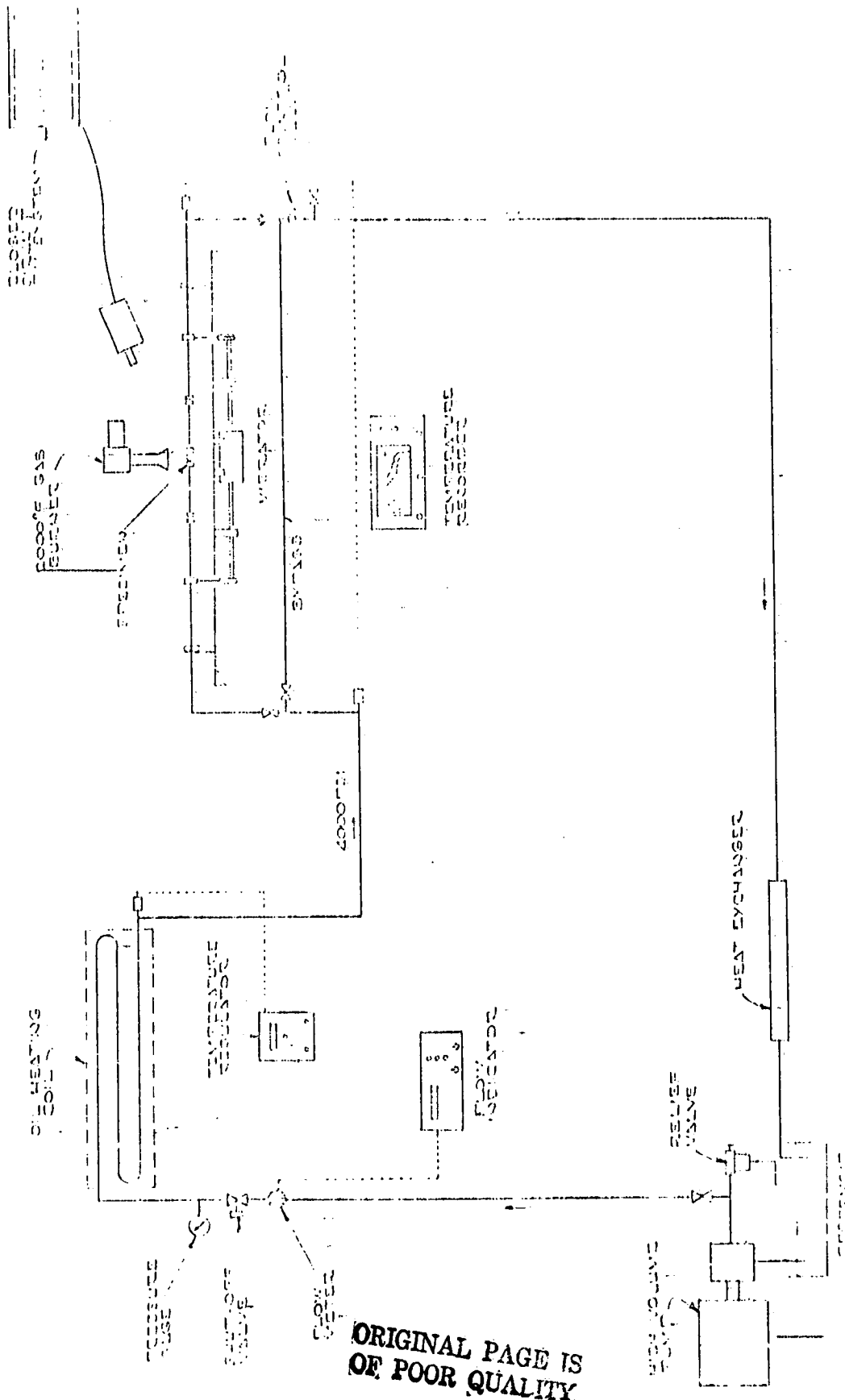

ORIGINAL PAGE IS
OF POOR QUALITY

FIGURE 11 FIRE RESISTANCE TEST FACILITY

SOUTHWEST RESEARCH INSTITUTE
DATA SHEET

SUBJECT TEST SEQUENCE NO. XI
FIRE RESISTANCE TEST

SHEET NO. _____ OF ¹²² SHEETS
PROJECT 03-3113-02
DATE _____
BY _____

SPECIMEN CODE NO.: _____

ASSEMBLY TORQUE: _____
(Minimum)

TEST FLUID TEMP.: _____

FLUID FLOW RATE: _____

PRESSURIZING FLUID: _____

OPERATING PRESSURE: _____

TEST RESULTS:

SUPPLEMENT NO. 1

to

CLASS "A" FIRE RESISTANCE TEST PROCEDURE
for the
TESTING OF BOSS TYPE SEPARABLE
FITTING ASSEMBLIES

CLASS "A" FIRE RESISTANCE TEST
for
BOSS TYPE SEPARABLE FITTING ASSEMBLIES
(Reference: Test Procedures for Unions)

A. TEST PARAMETERS

Same

B. TEST APPARATUS

Same plus Items 15 and 16 as follows:

15. Adapter: Vendor's boss recess to 3/4" pipe (see Fig. 11a).
16. Extension adapter to permit placement of boss and boss adapter in the middle of the flame path as required by ARP 1055.

C. TEST PROCEDURE

Same, but add Item 1a to read as follows:

- 1a. Assemble the extension adapter, boss adapter and tube/fitting specimen for installation in the mounting fixture. Installation is to be made with the extension and boss adapter downstream as shown in Figure 11a.

D. TEST RECORDS

Remove test specimen and examine for damage or deterioration. Record results of tests on attached data sheet.

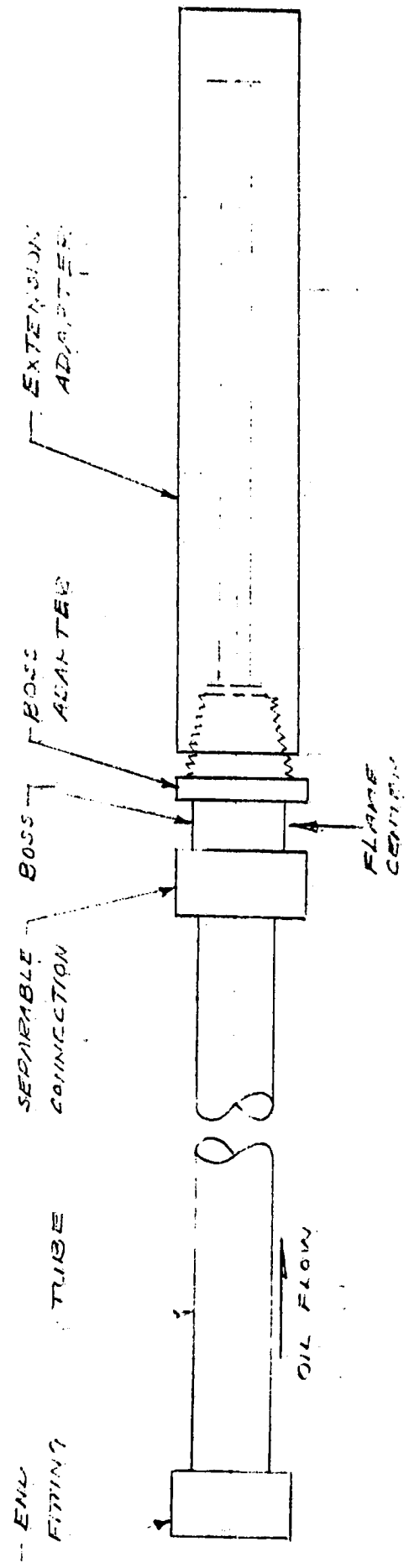

FIGURE 11a FIRE RESISTANCE BOSS TEST SPECIMEN ASSEMBLY

11. THERMAL SHOCK TEST

The purpose of this test is to determine the reaction of the fitting assembly to severe-temperature changes, both internally and externally with liquid and air mediums. The maximum and minimum temperature ratings of the particular class of fittings are the basis for these tests and are imposed by utilizing separate hot and cold chambers alternately for the air shock portion of the test, followed by alternately filling of the test assembly with liquid at both temperature extremes and slightly pressurizing with shop air. Each test series is followed by a proof pressure test to determine if any damage has occurred to the specimens as the result of the shock tests. Protective clothing, eye shields and gloves should be used as a precaution against injury from exposure to the hot oil and dry ice/alcohol mixtures used to conduct the liquid shock tests. A schematic layout of the liquid shock test facility is presented in Figure 12 following the test procedure.

Performance Evaluation Test No. 11

THERMAL SHOCK
(Reference: ARP-899)A. TEST PARAMETERS

1. Test Temperatures: -65°F ($\pm 5^{\circ}\text{F}$) for 4 hours/cycle (Class I and II)
 $+450^{\circ}\text{F}$ ($\pm 10^{\circ}\text{F}$) for 4 hours/cycle (Class I)
 $+275^{\circ}\text{F}$ ($\pm 10^{\circ}\text{F}$) for 4 hours/cycle (Class II)
2. Three Cycles: 4 hrs at -65°F and 4 hrs at $+450^{\circ}\text{F}$ or $+275^{\circ}\text{F}$

B. TEST APPARATUS

1. High temperature oven ($+450^{\circ}\text{F}$)
2. Low temperature chamber (-65°F)
3. Timer
4. Pressure fill fitting with 0-50 psig gage
5. Shop air supply.

C. TEST PROCEDURES

- *1. Install test article(s) in high temperature chamber after chamber temperature has been stabilized at $+450^{\circ}\text{F} \pm 10^{\circ}\text{F}$.
2. Set timer for 4 hours and remove test article at the end of 4 hours.
3. Within 5 minutes transfer test article(s) to the cold chamber with the temperature stabilized at $-65^{\circ}\text{F} \pm 5^{\circ}\text{F}$.
4. Set timer for 4 hours and remove test article(s) at that time.
5. Steps 1, 2, 3 and 4 constitute one cycle. Repeat Steps 1, 2, 3 and 4 to complete a total of 3 cycles.
6. Permit test specimen to stabilize at room temperature and conduct proof pressure test.
7. Following the air shock treatment above, conduct the low temperature liquid shock test on fittings starting with the fitting assembly at room temperature. Cap one end of the specimen assembly and attach the fill fitting to the other end.

*Note: For Class II specimens use hot temperature of 275°F .

THERMAL SHOCK (Cont'd)

8. Stabilize assembly at room temperature. Fill tube with fluid at -65°F . Cap fill chamber and pressurize with air to 10 psig. Check for leaks. Record results and remove fluid.
- *9. Immediately insert fluid with temperature stabilized at $+450^{\circ}\text{F}$ and pressurize test specimen with 10 psi shop air. Check for leaks. Record results and remove fluid. This constitutes one cycle.
10. Immediately repeat steps 8 and 9 until three complete cycles are accomplished.
11. Permit test specimen to stabilize at room temperature and conduct proof pressure test.
12. Record results following examination for signs of cracks, distortions, failures or gaps that may be indicative of an impending leak or failure.

*Note: For Class II specimens use hot temperature of 275°F .

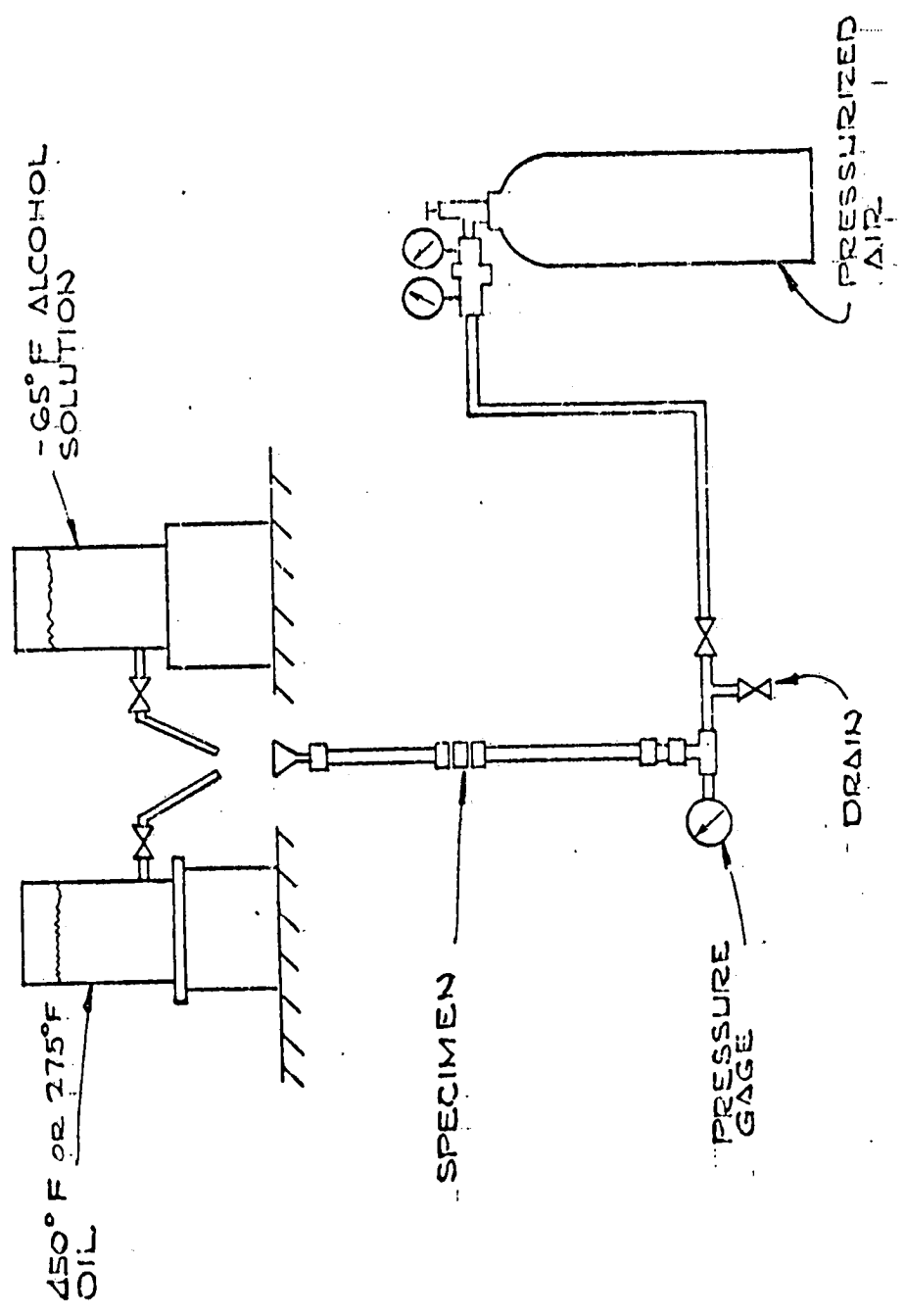

FIGURE 12 LIQUID SHOCK TEST ASSEMBLY

SOUTHWEST RESEARCH INSTITUTE
DATA SHEET

130

SHEET NO. _____ OF _____ SHEETS

PROJECT 0-111-100

SUBJECT Test Sequence No. VII

DATE _____

Thermal Shock Test

BY _____

Test Group: _____

Test Temp. High: _____

Low: _____

Test Air Pressure: _____

AIR SHOCK TESTS

Specimen Nos.	Cycle No. 1		Cycle No. 2		Cycle No. 3		Pressure Test Results
	Date	Start Time	End	Date	Start Time	End	

Remarks: _____

LIQUID SHOCK TESTS

Date: _____

Specimen Nos.	Cycle No. 1		Cycle No. 2		Cycle No. 3		Pressure Test Results
	Hot	Cold	Hot	Cold	Hot	Cold	

ORIGINAL PAGE IS OF POOR QUALITY

Proof

SUPPLEMENT NO. 1

to _____

THERMAL SHOCK TEST PROCEDURE
for the
TESTING OF BOSS TYPE SEPARABLE
FITTING ASSEMBLIES

THERMAL SHOCK TEST
for
BOSS TYPE SEPARABLE FITTING ASSEMBLIES
(Reference: Test Procedures for Unions)

A. TEST PARAMETERS

Same (use both air shock and liquid shock).

B. TEST APPARATUS

Same plus Items 6 and 7 as follows:

6. Boss adapter: Vendors boss recess to 3/4" pipe (see Fig. 12a).
7. Extension adapter to place boss/boss adapter in middle of test specimen (see Fig. 12a).

C. TEST PROCEDURES

Same with addition of Item 7a as follows:-

- 7a. Tube end of specimen is to be at the filler end while the extension adapter is at the lower end (see Fig. 12a).

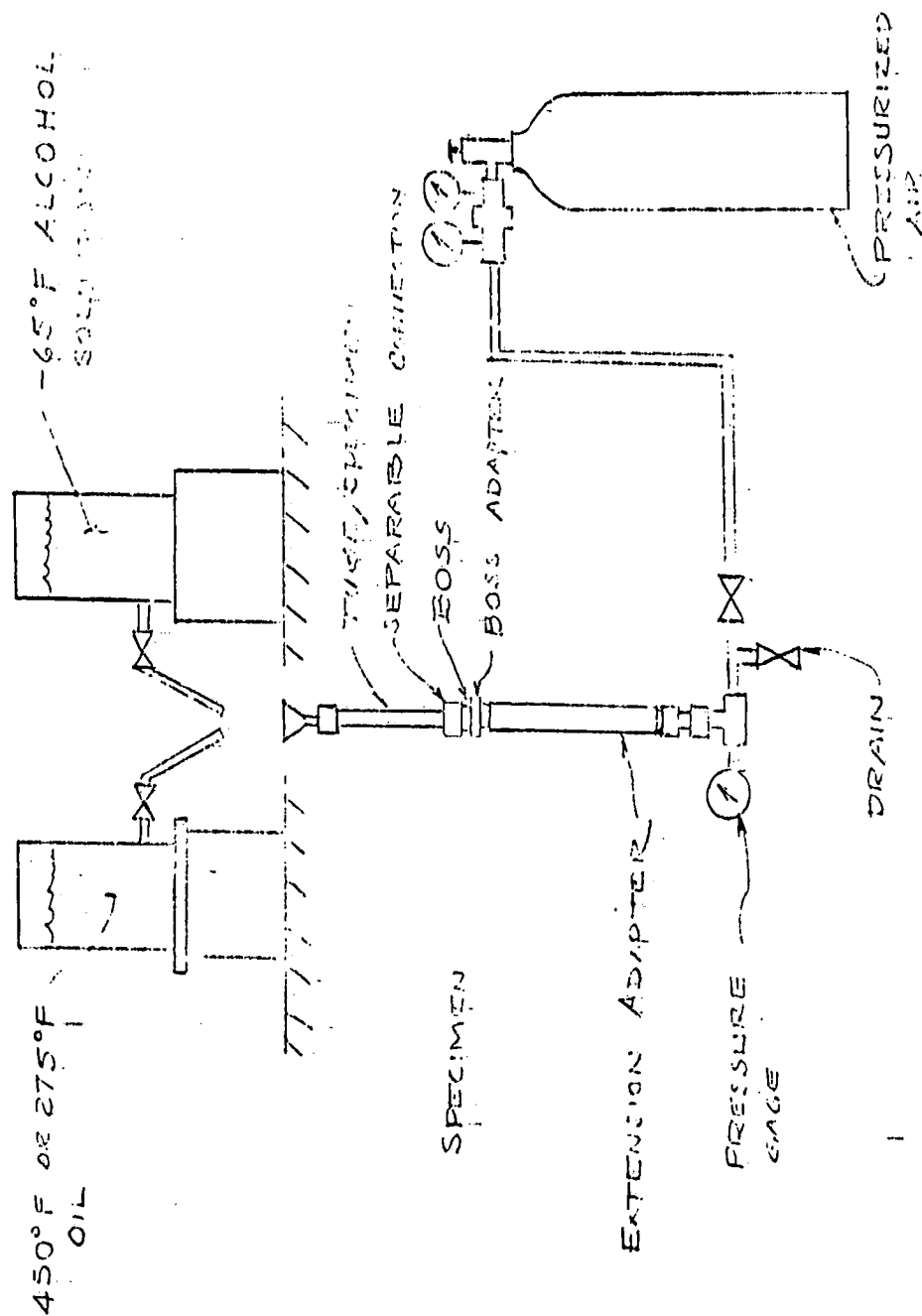

FIGURE 12a LIQUID SHOCK TEST ASSEMBLY - BOSS

ORIGINAL PAGE IS
OF POOR QUALITY

12. STRESS CORROSION TEST

This test method is intended to determine the resistance of the fitting assembly to a corrosive environment. The pressurized test specimen as depicted in Figure 13, following the test procedure, is alternately immersed into a pan of 6% heated salt water solution and then allowed to dry in a warm atmosphere. The test is conducted for a period of 96 hours. During this test the cantilevered specimen is also subjected to a bending stress level of 20,000 psi at a point on the tubing 1/8" from the tubing/union interface. This is accomplished with the aid of a strain gage mounted at that point.

A reserve salt water tank is required to permit replenishment of the solution in the bath as it evaporates while operating at the elevated temperatures. A forced warm air system is incorporated in the environmental chamber to speed up the drying process. After removal from the test fixture, the specimens are thoroughly cleaned with water and fine steel wool to remove the sediment of evaporated salt. This is followed with a close inspection of the tested assembly with a 10X magnifying glass to detect any signs of corrosive effects.

For the sake of ease in reporting the extent of visible corrosion on the test assemblies, the following criteria will be used:

Slight Corrosion = Barely visible evidence of change from
original form

Mild Corrosion = Few minor pits, scales, or discoloration

Moderate Corrosion = Pitting, scaling, etc. 30-50% over
surface area of fitting

Excessive Corrosion = Over 50% of surface area corroded.

Performance Evaluation Test No. 12

STRESS CORROSION

(References: ARP 899, FTS-151 Method 811.1 and MIL-F-18280C)

A. TEST PARAMETERS

1. Test chamber temperature 140°F (+10°F)
2. Salt solution temperature: 190°F (+10°F)
3. Immersion cycle time: 5 minutes in salt solution
4. Drying time after removal from salt solution: 25 minutes
5. Total time per cycle: 30 minutes
6. Total cycle time: 96 hours
7. Specimen internal hydraulic pressure: Class I (4,000 psi);
Class II (3,000 psi)
8. Bending stress produced by fixture: 20,000 psi @ strain gage
location

B. TEST APPARATUS

1. Environmental chamber for 140°F temperature
2. Cycling apparatus for 5-minute immersion and 25-minute
drying times per cycle
3. Salt solution: 6% NaCl @ 190°F
4. Elapsed time clock
5. Hydraulic pressure apparatus
6. Holding fixture for specimens to induce bending stress
7. Strain indicators

STRESS CORROSION (Cont'd)

C. TEST PROCEDURES

1. Mount a single element strain gage, Micro-Measurement Type EA-06-062ED-120, on the specimen as shown in Figure 13. The gage grid axis must parallel the specimen axis, and the centerline of the gage should be 1/8" from the tube/union interface
2. Install the fitting specimen(s) in the support fixture and balance the strain gage(s) to a null (zero) position on the strain indicator
3. Apply a bending load to the specimen(s) which will produce the stress level specified above. This is accomplished by positioning the bending load set screw (Fig. 13) on the end cap of the specimen and with it, deflecting the cantilevered specimen to a point which produces the predetermined strain as indicated by the strain gage and its monitoring system
4. Prepare 6% salt solution (NaCl)
5. Install test article(s) support fixture in chamber
6. Raise salt solution temperature to 190°F ($\pm 10^\circ\text{F}$) and stabilize
7. Attach hydraulic pressure source and apply specified pressure
8. Raise chamber temperature to 140°F ($\pm 10^\circ\text{F}$) and stabilize
9. Turn on automatic cycling apparatus and check time on first cycle
10. Set timer for 96 hours with daily checks to be made to insure continued cycling
11. After 96 hours of continuous cycling, shut off pressure, temperature and automatic cycling apparatus and allow specimen to cool
12. Remove specimen, rinse clean in tap water, and polish with steel wool. With the aid of a 10 power glass, examine test article(s) for corrosion penetration, cracks, pin holes or potential failures. When necessary longitudinally cut through or peel back fitting from tubing to determine extent of damage. Record results of the inspection
13. Perform burst test on one specimen and record results

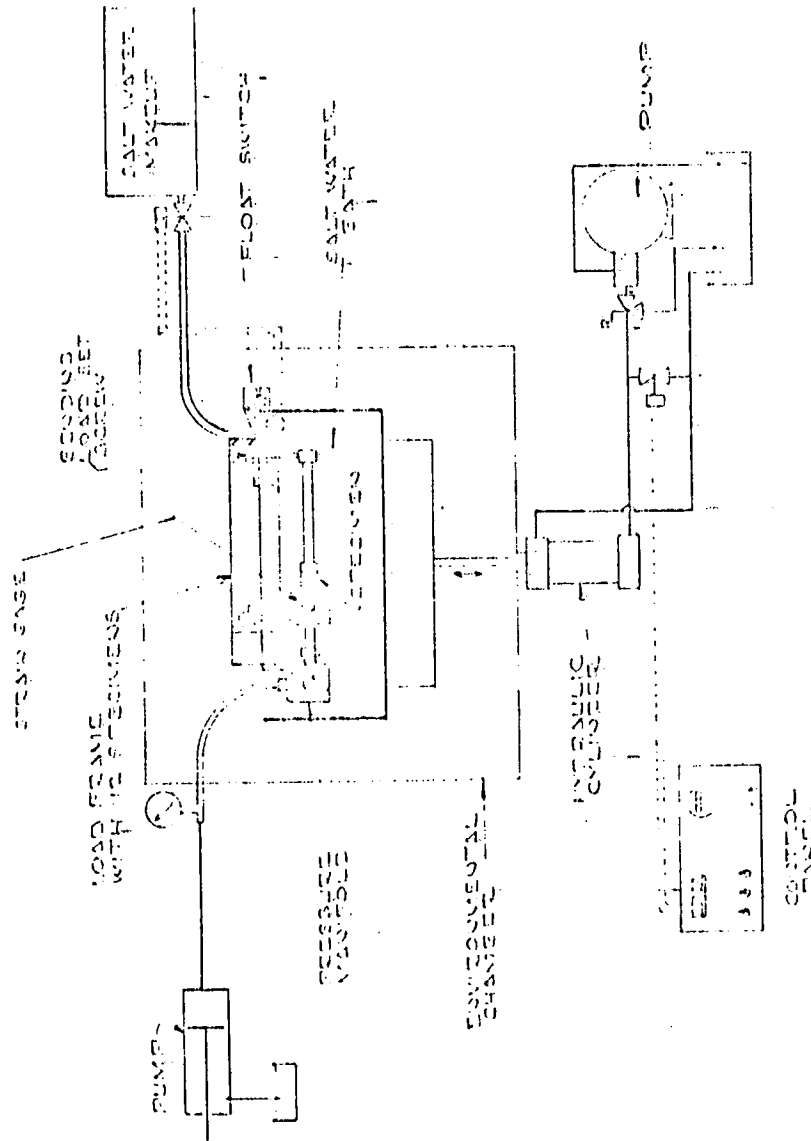

FIGURE 13 STRESS-CORROSION TEST FACILITY

ORIGINAL PAGE IS
OF POOR QUALITY

**SOUTHWEST RESEARCH INSTITUTE
DATA SHEET**

SHEET NO. 2 OF 2 SHEETS ¹⁴⁰
 PROJECT 03-3113-002
 DATE _____
 BY _____

SUBJECT Test Sequence No. VIII
Stress Corrosion Test

INSPECTION RESULTS FOLLOWING IMMERSION CYCLES

Specimen Code No.	Extent of Visible Corrosion*	Other Inspection Remarks

*Legend for "Extent of Visible Corrosion"

Slight = Barely visible evidence

Mild = Few minor pits, scales or discoloration

Moderate = Pitting, scaling, etc., 20-50% of surface area of film

Excessive = Over 50% corrosion

SUPPLEMENT NO. 1

to

STRESS CORROSION TEST PROCEDURE
for the.
TESTING OF BOSS TYPE SEPARABLE
FITTING ASSEMBLIES

STRESS CORROSION TEST
for
BOSS TYPE SEPARABLE FITTING ASSEMBLIES
(Reference: Test Procedure for Unions)

A. TEST PARAMETERS

Same.

B. TEST APPARATUS

Same with addition of Items 8 and 9 as follows:

8. Boss adapter: Vendors boss recess to 3/4" pipe (see Fig. 13a).
9. Extension adapter to fit into manifold thereby extending boss adapter for required bending stress (see Fig. 13a).

C. TEST PROCEDURES

Same except reference is to Figure 13a and tube/boss interface instead of tube/union interface.

ORIGINAL PAGE IS
OF POOR QUALITY

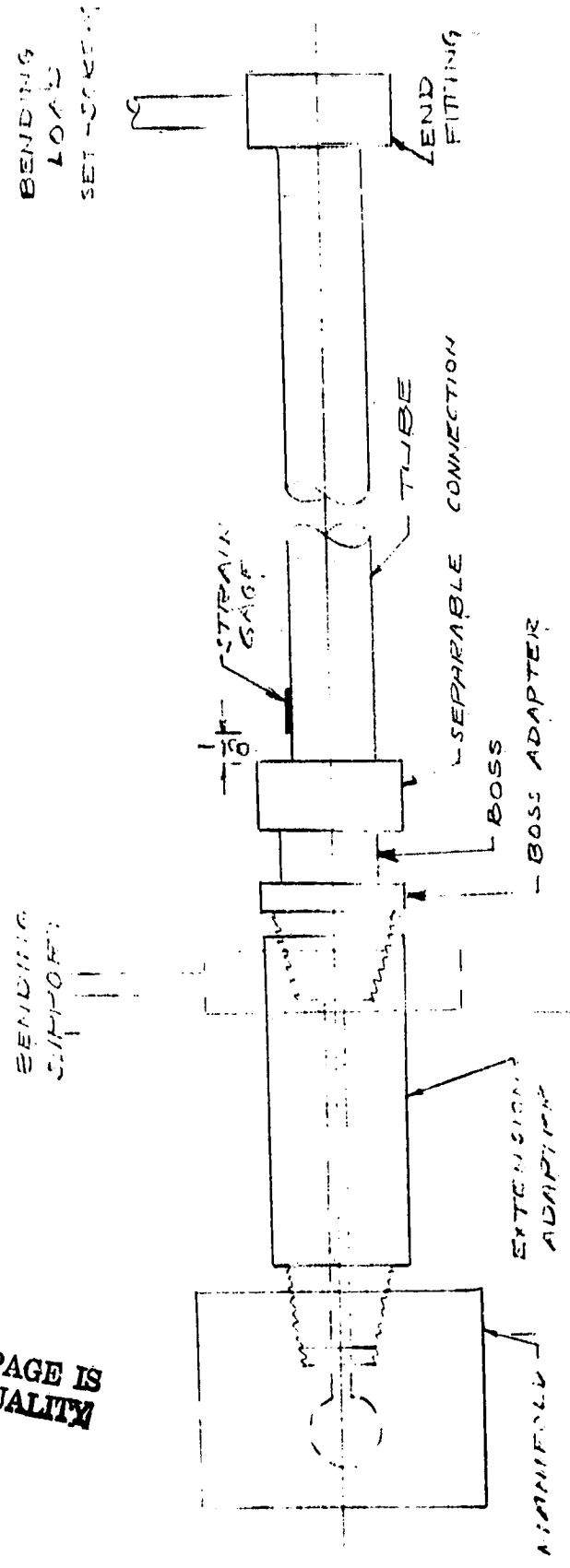

FIGURE 13a STRESS CORROSION BOSS TEST SPECIMEN INSTALLATION

13. VIBRATION TEST

This test is intended to determine the various vibration parameters that can be withstood by the union fitting/tube assemblies. The test conditions taken from MIL-STD-810B simulate to some degree the conditions that could be attained in actual service experience. Due to the variations in design, assembly, installation and operation, no test can cover all the conditions a system will experience; however, the series of tests scheduled within this test procedure exposes the test specimens to a general cross-section of vibration parameters that probably will be found in today's jet aircraft and aerospace systems.

The method of mounting the test specimen has a significant effect upon the test results and once again simulation of actual installations must be relied upon. The cantilever holding fixture permitted development of excessively high "g" forces due to the heavy mass of the unions and terminal end fittings. Therefore, the holding fixture was changed to a simple beam type with two point suspension and clamping. The cantilever type fixture will be used for testing of the boss fittings and the end cap will be of a minimum weight to reduce the "g" forces under these conditions. The stiffness factor of the larger diameter tubing/fittings will have a significant impact on the test results. Therefore, in the design of clamping/restraints, the ideal unsupported span for a -16 tube may be detrimental spacing for a -6 tube.

Performance Evaluation Test No. 13.

VIBRATION TEST
(Separable Designs Only)
(References: MIL-STD-810B)

A. TEST PARAMETERS

1. Resonance search: 10-min
2. Resonance dwell: 30-min dwell time at each resonance
3. Sinusoidal cycling: 3 hours (less dwell time) = 2.5 hours
4. Sweep time: 15 minutes (frequency 5-500-5) (Fig 514.1 curve "z")
20 minutes (frequency 5-2000-5) (Fig 514.1 curve "z")
5. Ambient temperature
6. Internal pressure: 400 psi for leak or failure determination

B. TEST APPARATUS

1. Single end holding fixture for a boss type specimen
2. Simple beam type holding fixture for union type specimens
3. Vibration table mount for fixture: 2 axis
4. Automatic vibration exciter system
5. Vibration pickups and accelerometers

C. TEST PROCEDURES

1. Mount one each test specimen on simple beam type-holding fixture (supported each end).
2. Attach specimen holding fixture solidly to shaker table mount with tube in a horizontal position and fill with fluid.
3. Install vibration and accelerometer pickups on test specimen and pressurize to 400-psi using nitrogen.

VIBRATION TEST (Cont'd)

4. Start resonant search at reduced level by sweeping through the spectrum for determination of the resonant frequencies of the test article.
5. Rotate the fixture and test specimen through two axis; parallel and normal to the longitudinal axis of the tube / fitting specimen. Determine resonant frequency in each axis.
6. Perform resonance dwell by exciting the test specimen at each of the most severe, previously determined resonance frequencies. Resonance dwell must be performed for 50 minutes on the critical axis. If more than one critical frequency exists, resonance dwell must be conducted for each.
7. Vibrate the test specimen along the critical axis in accordance with applicable test levels, frequency range, and times noted in Tables 514.1-I and Figure 514.1-I from MIL-STD-810B. The frequency of applied vibration shall be swept over the specified range logarithmically in accordance with Figure 514.1-I using the frequency band in Table 514.1-IX.
8. Following completion of the sinusoidal cycling/sweeps, the test article is to be removed, disassembled and inspected for signs of cracks or other failures as well as galling, fretting or plastic deformation. Record the results.
9. If no resonance frequency can be determined for a specimen, the specimen will then be cycled at 500 hertz in Step 6.

SUPPLEMENT NO. 1

to

VIBRATION TEST PROCEDURE
for the
TESTING OF BOSS TYPE SEPARABLE
FITTING ASSEMBLIES

VIBRATION TEST
for
BOSS-TYPE SEPARABLE FITTING ASSEMBLIES
(Reference: Test Procedure for Unions)

A. TEST PARAMETERS

Same.

B. TEST APPARATUS

Same.

C. TEST PROCEDURE

Same except use single end holding fixture for the boss assemblies.

14. ROTARY FLEXURE TEST WITH S/N DATA DEVELOPMENT

The rotary beam method of testing will be used throughout this test program for the flexure test and development of S/N characteristic fatigue life curves. This is by far the most stringent test conducted in this program, and is considered by some to be the most useful in determining worthwhile data for the designer. Therefore considerable effort has been made to perform the tests in the most repetitive manner possible - by the most simple, and efficient machine design; by standard procedures which are easily followed.

Generally the recommendations found in ARP1185 (proposed) were used as guidelines in performance of the test. The test facility is shown schematically in Figure 15 and as can be seen, the specimen is clamped in a manner which will permit flexure of the entire union joint assembly. Since the original work statement stipulated that union-type fittings would be tested, a change from the test set-up recommended in ARP1185 was necessary.

The actual test fitting envelope, with regard to this test program, is defined as the fitting itself and the portion of tubing on either side within one diameter of the tube/fitting interface. In the case of a butt welded separable fitting the tube/fitting interface would be at the weld on either side of the actual joint portion of the fitting. With respect to a permanent braze-type union, the interface would be the edges on either end of the fitting.

The strain gage used in determining the bending stress applied to the fitting envelope is located $1/8$ " from the tube/union interface on the clamp side of the fitting. The specimen is clamped at a point which is equal to

1-1/2 tube diameter distance from the tube/fitting interface. This was determined as being the optimum point to grip the tube rigidly with the minimum of strain effect on the gage caused by the clamping forces.

The tubing directly underneath the edge of the clamp bushing was spiral wrapped with a 2-mil thick TFE tape to reduce chaffing of the tube which may precipitate premature tube failures. The edge of the bushing I. D. was also rounded to prevent a high stress riser.

During the initial equipment "shake-down" tests, two uniaxial strain gages were mounted at 90° apart on the trial test specimens for determination of bending stress levels and alignment. Since installation procedures allow the test specimen assembly to seek its own alignment and true zero by loosening of the swivel base tailstock and retightening while the drive motor is running, only one strain gage was needed to determine static stress levels on all subsequent test runs. Dynamic stress level correction factors required because of the inherent forces produced by the machine were determined at each position during trial tests with the aid of an oscilloscope, and checked periodically during the test program.

Performance Evaluation Test No. 14

ROTARY FLEXURE TEST

(For 304-1/811, Armco-21-6-9 S. S. and TI-3Al-2.5V Tubing)

(Reference: MIL-F-18280C, ARP-1185)

A. TEST PARAMETERS

1. Test Pressure (psig): 4,000 \pm 25 (Type I)
3,000 \pm 25 (Type II)
400 \pm 10 (Type I and II, zero pressure)
2. Test Temperature ($^{\circ}$ F): -65 $^{\circ}$ F \pm 10; +450 $^{\circ}$ F \pm 10 $^{\circ}$; Room Temp.
(Type I)
-65 $^{\circ}$ F \pm 10; +275 $^{\circ}$ F \pm 10 $^{\circ}$; Room Temp.
(Type II).
3. Temperature/Pressure Combinations: Any combination of temperatures and pressures noted for Type I or Type II fittings may be used to develop rotary flexure/fatigue S-N curves.
4. Number of rotations: 10^7 (two specimens minimum).
5. Rotation Rate: 3,000 \pm 150 rpm
6. Rotary Bending Stress: That which is required to develop an acceptable S-N curve with at least two points beyond 10^7 .
7. Pressurizing Media: Chevron M2V hydraulic fluid or equivalent for high temperature tests - water for room temperature tests.

B. TEST APPARATUS

1. Environmental chamber
2. Rotary flexure test machine
3. Hydraulic pressure pump, 6,000 psig output pressure
4. Ames dial gage, 0.001-inch graduations
5. Bourdon-type pressure gage, 0-6,000 psig
6. Oscilloscope
7. Temperature controller
8. Temperature recorder
9. Calibration equipment as required for above instruments.

C. TEST PROCEDURES

1. At location "A" on the rotary flexure specimen(s) (see Fig. 14) affix a single element strain gage (Micro-Measurement Type EA-06-062ED-120 (-6 specimen) or EA-06-125AD-120 (-10 and -16 specimen). The gage grid axis must parallel the specimen axis. Also spiral-wrap the 2" long portion of the

specimen which will be within the front part of the brass clamp bushing with 1/2" wide teflon tape normally used for sealing pipe threads. This is done to prevent chaffing of the tubing under the clamp bushing.

2. With the aid of a dial-gage, adjust the loading head collet (Fig. 14) so that the wobble bearing housing is near zero eccentricity (variation should not exceed .004 TIR - Total Indicator Reading), at each test station on the flexure machine.
3. Loosely cradle each specimen in its respective brass clamp bushings on the lower half of the specimen support, and insert the load pin into the wobble bearing. Position the specimen longitudinally so that the edge of the union envelope (in some cases the butt weld between fitting stub and tubing) is 1.5 tubing diameter distance from the edge of the clamp bushing, and has a space of 3/8" between the specimen end cap and wobble bearing housing (Figure 14). Orient the specimen so that the strain gage (Location A) is the uppermost part of the specimen, to facilitate subsequent application of the bending load.
4. Connect all strain gages to the balancing and conditioning circuits, balance and zero the individual strain gages.
5. Lower the upper half of the specimen support into position and tighten all bolts to a snug tightness being careful not to exceed a clamping strain of 200 μ in/in on each specimen. (Normally snug tightness produces slightly more/less than 100 μ in/in strain). Excessive strain requires inspection of the clamp fixtures and specimen to determine cause, which must be eliminated if possible before reinstallation.
6. Loosen the alignment bolt to the orbital base of the lower half of the specimen support, allow the drive motor to run briefly, and retighten the alignment bolt while motor is running. This process should settle the entire assembly (loading head, test specimen, and specimen support), to as near a perfect alignment as possible. Check that all bolts are tightened securely.
7. Disregard strains due to foregoing installation procedure, and again balance strain gage output to a null (zero) position. This will be the test zero position.

ROTARY FLEXURE (Cont'd)

8. Rotate the loading head through one complete revolution, noting and recording as the bearing housing revolves, any departure of strain from the test zero obtained in Step 7. Any variation of $\pm 5 \mu$ in./in. requires special analysis of the cause and subsequent dispensation.
9. Rotate the loading head so that the axis of loading is vertical, in line with the strain gage on the specimen, and the adjustment screw "A" is topside. Retract adjustment screw "B" and advance screw "A" until the desired strain reading is obtained. Retighten adjustment screw "B". (Note: with the aid of a dial gage, record the final displacement of the specimen by positioning the dial shaft on the hex portion of the cap at the pin end of the specimen during the loading process.)
10. Slowly rotate the loading head through two or three revolutions noting with each turn the maximum and minimum strain values. These values should be relatively equal in magnitude (within 50 min/in.) and opposite in sign. If not, reduce the cantilevered load, remove the specimen from the machine, and if no other cause is found, replace old strain gage with a new gage and repeat steps 3 through 10. Record these test strain values. (Note: Dynamic strains are calculated on the test log using a correction factor of 1.1 which was determined by preliminary tests conducted with the aid of an oscilloscope.)
11. Repeat Steps 3 through 10 for all stations in which a specimen is to be tested.
12. Record timer setting for each test position and check operation of each pressure shut-in switch. Secure the test machine making certain all protective guards are in place. Introduce required pressure and check for leaks. Raise temperature to level as required by test and allow to stabilize. (Note: During increase in temperature, periodic venting of pressure must take place to prevent overpressurization of the test specimen.)

*Refer to sequence testing chart for required pressures and temperatures.

MS fittings will use 275°F temperature and 3,000 psig pressure. Zero pressure tests will use 400 psig pressure.

ROTARY FLEXURE (Cont'd)

13. Start each test position and observe the operation visually until it is apparent that the test specimens and all components are performing as intended. During the subsequent test period, pressures in each specimen should be monitored and controlled at the levels required by the particular test. This can be accomplished by periodic manual venting of excess pressure buildup due to heating in the specimen caused by the flexure cycles.
14. Failure of any specimen will automatically stop that test machine. If failure occurs, record the number of cycles completed and calculate the time under test to the point where stoppage occurred. (Note: Machine speed = 3,000 rpm.) Enter pertinent data in the test log with apparent reason for failure.
15. The recording of the final displacement on the head stock is important because once the machine starts running, reliability of the strain gages reduces with the number of cycles. Therefore, any check for stress must be correlated by displacement.
16. Upon completion of 10^7 rotary cycles, shut off the test machine and reduce the chamber temperature. Remove specimens and inspect the test fittings for damage, deformation or other deleterious effects. Record all pertinent data in the test log and photograph specimens as required.
17. In this program, the rotary flexure and rotary flexure fatigue data are to be generated for use in plotting the S-N curve and verifying the endurance limit. The first tests will be conducted at three stress levels to establish the general S-N curve. From the curve the endurance limit will be determined. The remaining tests will be used to establish and/or verify the endurance limit. All tests will utilize the rotary flexure test method outlined in the preceding steps.

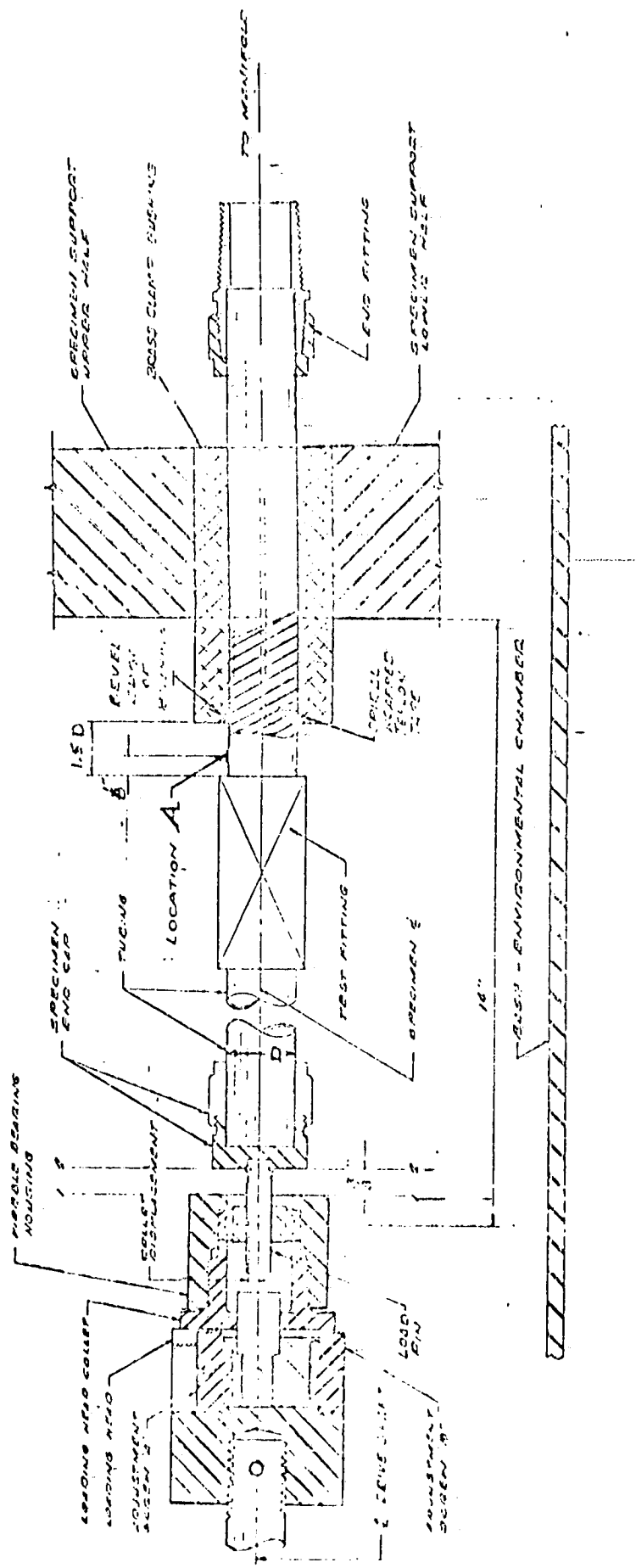

FIGURE 14 INSTALLATION OF A TEST SPECIMEN (TYPICAL)

ORIGINAL PAGE IS OF POOR QUALITY

ORIGINAL PAGE IS
OF POOR QUALITY

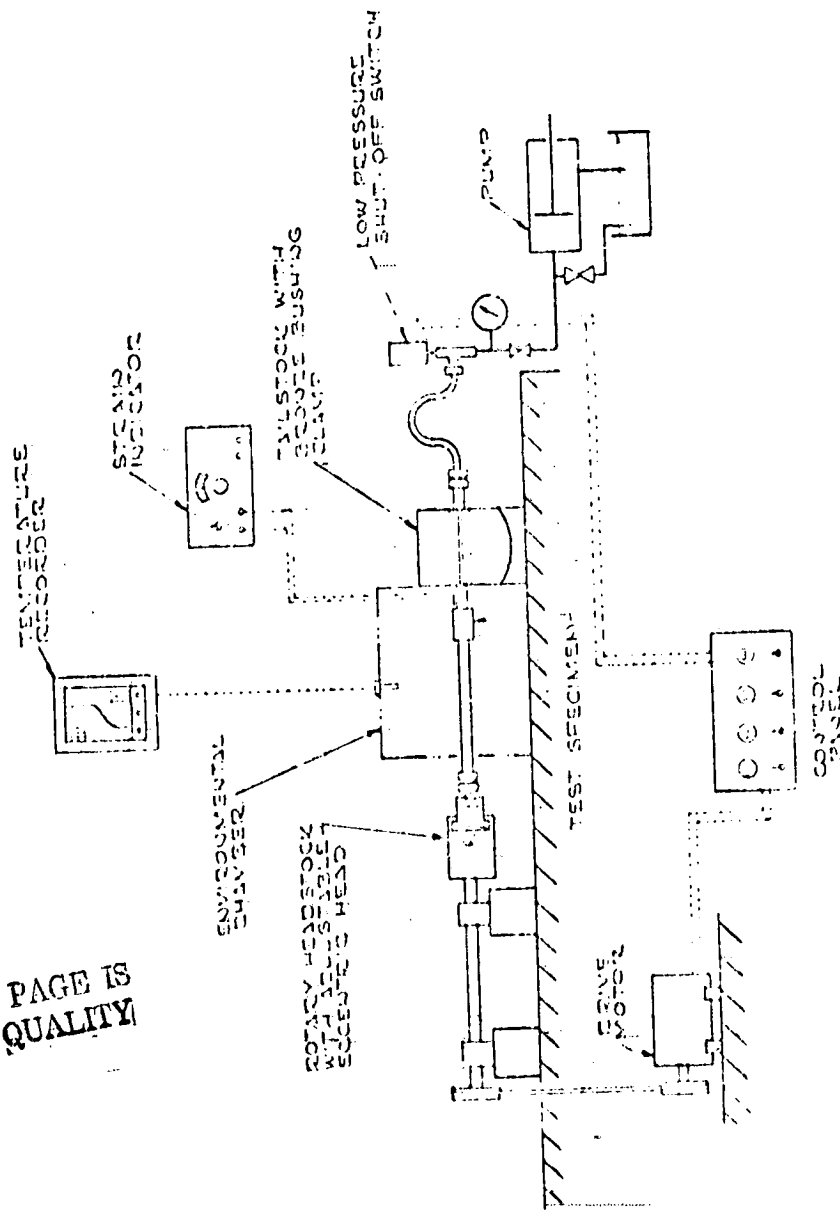

FIGURE 15 ROTARY FLEXURE TEST FACILITY

SUPPLEMENT NO. 1

to

ROTARY FLEXURE/FATIGUE TEST PROCEDURE
for the
TESTING OF BOSS TYPE SEPARABLE
FITTING ASSEMBLIES

ROTARY FLEXURE TEST —
for
BOSS TYPE SEPARABLE FITTING ASSEMBLIES
(Reference: Test Procedure for Unions)

A. TEST PARAMETERS

Same.

B. TEST APPARATUS

Same, with addition of Items 10 and 11 as follows (see Fig. 14).

10. Boss adapter: Vendors boss recess to 3/4" pipe (see Fig. 14a).
11. Extension adapter for clamping in the tail stock and to provide installation point for boss adapter (see Fig. 14a).

C. TEST PROCEDURES

1. At location "A" on the rotary flexure specimen(s) (see Fig. 14a) affix a single-element strain gage (Micro-Measurement Type EA-06-062ED-120 (-6 specimen) or EA-06-125AD-120 (-10 and -16 specimen). The gage grid axis must parallel the specimen axis.
2. With the aid of a dial gage, adjust the loading head collet (Fig. 14a) so that the wobble bearing housing is near zero eccentricity (variation should not exceed .004 TIR-Total Indicator Reading), at each test station on the flexure machine.
3. Loosely cradle the extension adapter portion of the specimen in the lower half of the specimen support, and insert the load pin into the wobble bearing. Position of the specimen longitudinally for a space of 3/8" between the specimen end cap and wobble bearing housing (Fig. 14a). Orient the specimen so that the strain gage (Location A) is the uppermost part of the specimen, to facilitate subsequent application of the bending load.
4. Connect all strain gages to the balancing and conditioning circuits, balance and zero the individual strain gages.
5. Lower the upper half of the specimen support into position in the tail stock and tighten all bolts to a snug tightness.
6. Loosen the alignment belt to the orbital base of the lower half of the specimen support, allow the drive motor to run briefly, and

ROTARY FLEXURE TEST (Cont'd)

retighten the alignment bolt while motor is running. This process should settle the entire assembly (loading head, test specimen, and specimen support), to as near a perfect alignment as possible. Check that all bolts are tightened securely.

7. Disregard strains due to foregoing installation procedure, and again balance strain gage output to a null (zero) position. This will be the test zero position.
8. Rotate the loading head through one complete revolution, noting and recording as the bearing housing revolves, any departure of strain from the test zero obtained in Step 7. Any variation of $\pm 5 \mu$ in./in. requires special analysis of the cause and subsequent dispensation.
9. Rotate the loading head so that the axis of loading is vertical, in line with the strain gage on the specimen, and the adjustment screw "A" is topside. Retract adjustment screw "B" and advance screw "A" until the desired strain reading is obtained. Retighten adjustment screw "B". (Note: with the aid of a dial gage, record the final displacement of the specimen by positioning the dial shaft on the hex portion of the cap at the pin end of the specimen during the loading process.)
10. Slowly rotate the loading head through two or three revolutions noting with each turn the maximum and minimum strain values. These values should be relatively equal in magnitude (within 50 min/in.) and opposite in sign. If not, reduce the cantilevered load, remove the specimen from the machine, and if no other cause is found, replace old strain gage with a new gage and repeat Steps 3 through 10. Record these test strain values. (Note: Dynamic strains are calculated on the test log using a correction factor of 1.1 which was determined by preliminary tests conducted with the aid of an oscilloscope.)
11. Repeat Steps 3 through 10 for all stations in which a specimen is to be tested.
12. Record timer setting for each test position and check operation of each pressure shut-in switch. Secure the test machine making certain all protective guards are in place. Introduce required pressure* and check for leaks. Raise temperature to level as

*Refer to sequence testing chart for required pressures and temperatures. MS fittings will use 275°F temperature and 3,000 psig pressure. Zero pressure tests will use 400 psig pressure.

ROTARY FLEXURE TEST (Cont'd)

required by test and allow to stabilize. (Note: During increase in temperature, periodic venting of pressure must take place to prevent overpressurization of the test specimen.)

13. Start each test position and observe the operation visually until it is apparent that the test specimens and all components are performing as intended. During the subsequent test period, pressures in each specimen should be monitored and controlled at the levels required by the particular test. This can be accomplished by periodic manual venting of excess pressure buildups due to heating in the specimen caused by the flexure cycles.
14. Failure of any specimen will automatically stop that test machine. If failure occurs, record the number of cycles completed and calculate the time under test to the point where stoppage occurred. (Note: Machine speed = 3,000 rpm.) Enter pertinent data in the test log with apparent reason for failure.
15. The recording of the final displacement on the head stock is important because once the machine starts running, reliability of the strain gages reduces with the number of cycles. Therefore, any check for stress must be correlated by displacement.
16. Upon completion of 10^7 rotary cycles, shut off the test machine and reduce the chamber temperature. Remove specimens and inspect the test fittings for damage, deformation or other deleterious effects. Record all pertinent data in the test log and photograph specimens as required.
17. In this program, the rotary flexure and rotary flexure fatigue data are to be generated for use in plotting the S-N curve and verifying the endurance limit. The first tests will be conducted at three stress levels to establish the general S-N curve. From the curve the endurance limit will be determined. The remaining tests will be used to establish and/or verify the endurance limit. All tests will utilize the rotary flexure test method outlined in the preceding steps.

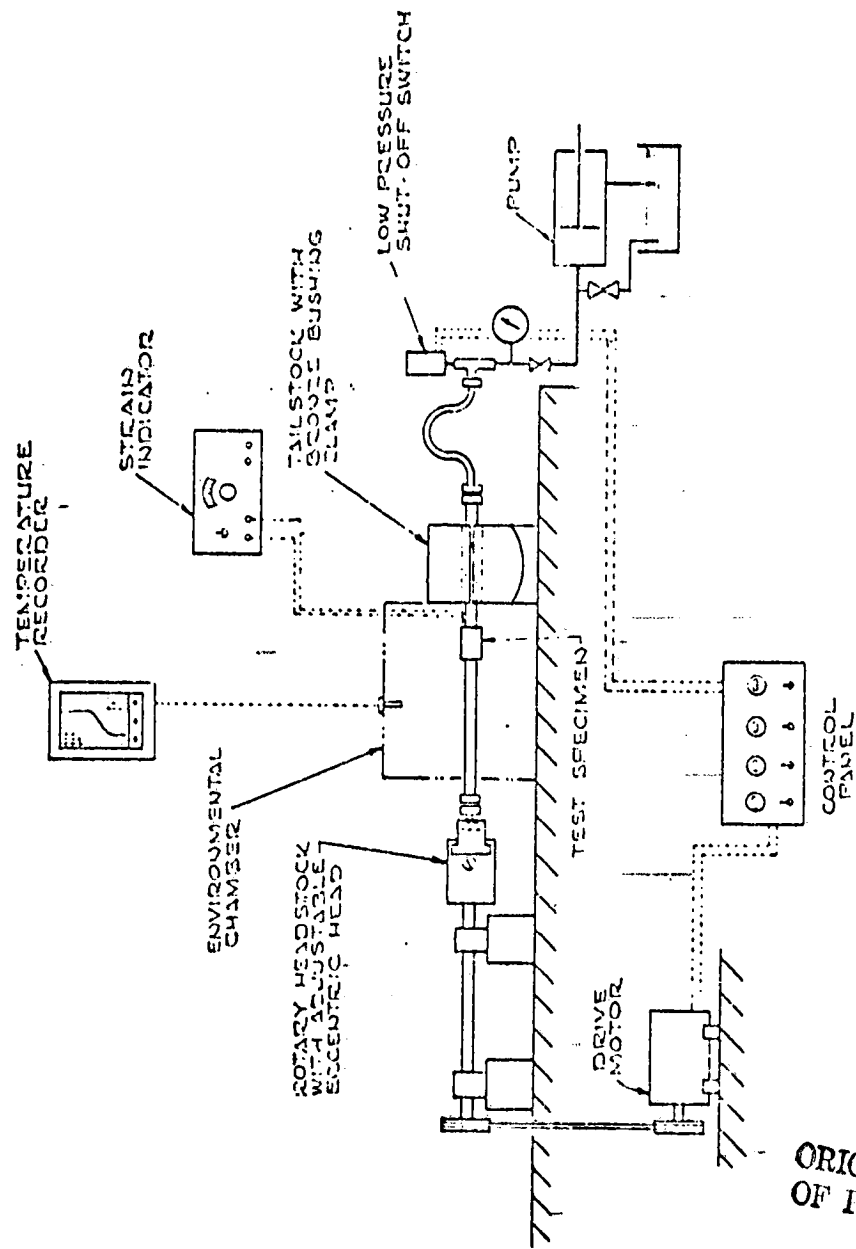

FIGURE 15 ROTARY FLEXURE TEST FACILITY

ORIGINAL PAGE IS OF POOR QUALITY

VII. TEST SEQUENCE AND QUANTITIES

The fifteen test procedures could require a large quantity of fittings unless consideration is given to the maximum utilization of each test specimen for generation of usable data. The Test Sequence Chart shown in Figure 3 will be referred to throughout the following discussion by noting the roman numeral group number. It is possible to reduce the number of specimens still further or with the same number of specimens, generate more data; especially in arrangement of the gaseous leakage, proof and/or burst tests, since results from these tests indicate the degree of degradation induced by the previous test(s). However, past experience has proven that the proof and burst test data is not necessarily the more important.

The more important, useful and critical tests are considered to be:

- Rotary Flexure
- Fatigue (Rotary Flexure)
- Impulse
- Vibration
- Proof/Burst

These are listed in order of criticality and for some reason the more critical the tests, the more difficult they are to conduct.

The test sequence was developed by first placing each of the required tests in groups with initial verification checks or proof pressure or gaseous leakage used wherever it was most advantageous. A negative approach was taken with reference to the test specimens received from the various participants, in that it was assumed that every fitting received would be bad

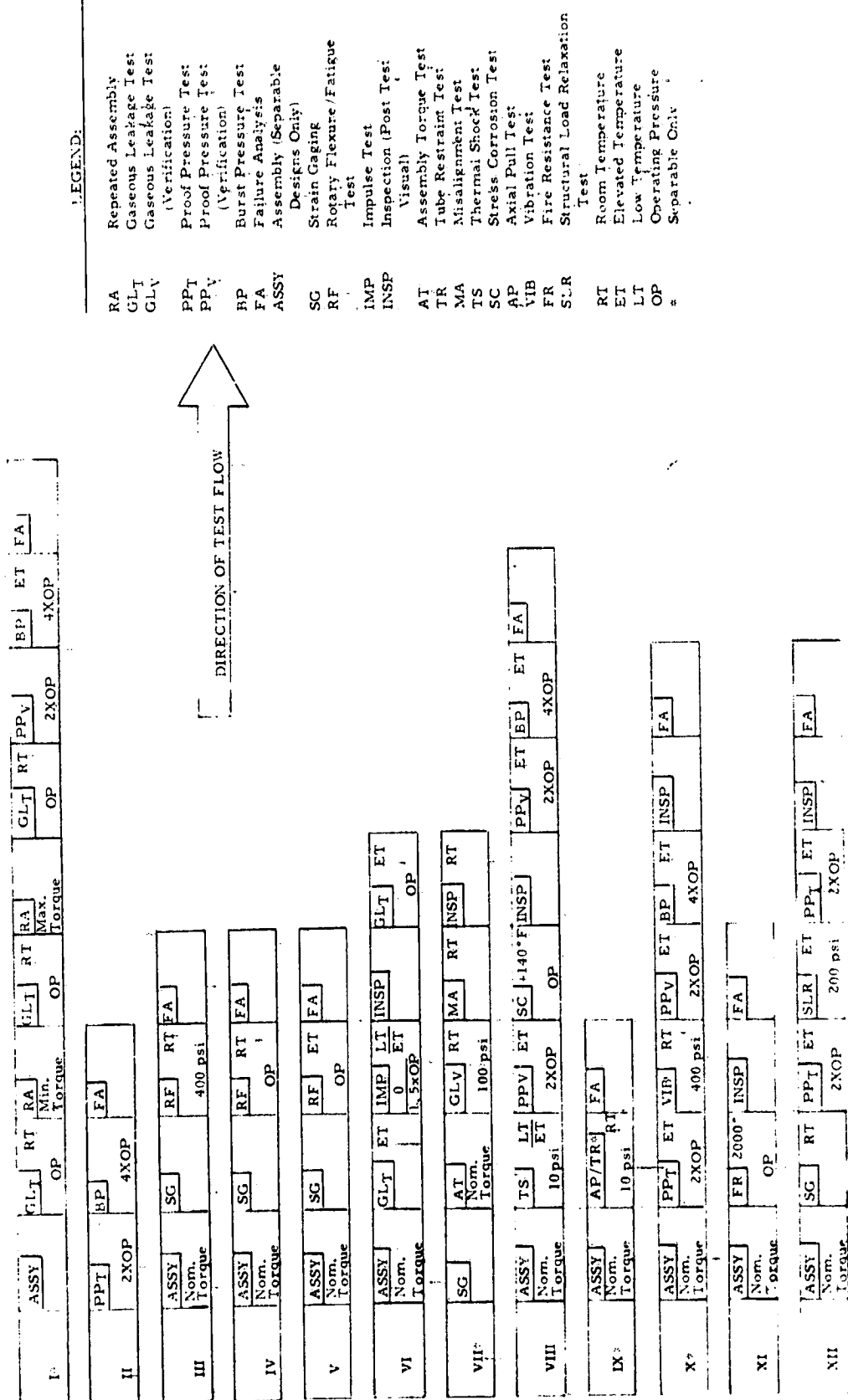

FIGURE 3 PERFORMANCE EVALUATION TEST SEQUENCE

and would normally fail. With this approach, the verification tests were used to prove the point before and/or after the specific test designated for the particular group.

The next step was to determine which tests could be combined to reduce the number of specimens required for the total program due to the economic restraints on the program. Unfortunately, too many of the tests are either destructive or deteriorated the specimen to the point that it would be unacceptable to attempt to use it for another test because the degree of damage is an unknown factor. Test setups for assembly torque and misalignment fitted together, as did thermal shock and stress corrosion. One other combination was found to be possible because they both utilized the same test fixture; axial pull and tube restraint. Reduction in the required number of specimens by the assembly of these three combinations was offset by the detailed requirements of the rotary flexure and rotary fatigue tests wherein several test points per stress level and temperature are required to develop fatigue data and the S-N curve data with an acceptable confidence level.

Table 2 presents the quantity of test specimens recommended per circuit sequence and the following comments apply to the recommended number of specimens per test:

Group 1 Since this is applicable to separable fittings only, the degree of deterioration due to repeated assembly/disassembly is a function of the mating materials and the joint design. Therefore, a maximum of 100 specimens is recommended with maximum test. Class 15000

TABLE 2

RECOMMENDED MINIMUM TEST SPECIMENS REQUIRED.
PER TYPE AND GROUP*

	<u>Quantity Permanent</u>	<u>Quantity Separable</u>
Group I	0	2
Group II	2	2
Group III	6	6
Group IV	6	6
Group V	6	6
Group VI	4	4
Group VII	0	2
Group VIII	3	3
Group IX	3	3
Group X	0	2
Group XI	1	1
Group XII	<u>0</u>	<u>2</u>
Total	31	39

*Refer to Test Sequence Chart for Group Numbers . .

rather than proof pressure is recommended for verification of leakage. If the results are positive and negative, a third specimen is recommended.

Group II: This is the combined test of proof and burst pressure on a new specimen. A minimum of two specimens is recommended. If the results are both positive and negative, a third specimen is recommended.

Group III
Group IV
Group V These three groups involve rotary flexure/fatigue testing of specimens at the varying combinations of pressure and temperature. Since the S-N curves involve a rather broad scatter of data per point, a minimum of three specimens per point is recommended. Therefore, a minimum of nine specimens per group should be used to establish a reasonable confidence level. Due to the high cost of the large number of specimens in this program, only six specimens per group were used. A minimum of two specimens for endurance limit runout to 10^7 is desired.

Group VI: This group involves the impulse testing which is also considered to be a fatigue type test, but with fewer variables. A minimum of four specimens is recommended with the optimum number selected as six.

Group VII: This group involves assembly torque and misalignment tests and a minimum of two specimens are recommended with an optimum number of three. These tests are applicable to separable fittings only. A third specimen should be added if the results on two specimens turn out to be positive and negative.

Group VIII: This group involves thermal shock and stress-corrosion tests. Due to the variables associated with these tests, a minimum of three specimens is recommended. The maximum or optimum number is dependent on the degree of data scatter from the minimum number.

Group IX: This group involves the axial pull and tube restraint tests wherein the tube restraint test is applicable to separable fittings only. Axial pull test is applicable to both permanent and separable type fittings. A minimum of two specimens is recommended for these tests.

- Group X: This group involves the vibration testing of separable fittings only. A minimum of two specimens is recommended. However, if one passes and one fails, a third specimen should be utilized to establish the trend.
- Group XI: This group involves the fire-restraint test and a minimum of one specimen should be used. Only under extreme circumstances should additional specimens be required.
- Group XII: This group involves the structural load relaxation (creep) test applicable to separable fittings only and a minimum of two specimens is required. A third specimen is recommended if the results are positive and negative.

The test specimens should be accompanied by sufficient design detail to permit adequate analysis of any failures. Details of assembly methods, procedures, and equipment should also accompany the test specimens since these factors have a bearing on the tests as well as failure analysis.

The quantities discussed are applicable to one tube/fitting configuration and/or size only. The quantity for separable fittings and for permanent fittings of one size and one type of tubing are noted in Table 2. A change in size requires a similar quantity. A change in tubing specifications requires a similar quantity. For example:

- (a) A permanent fitting (union) design with plans to test one size:
Requires $31 \times (1) = 31$ specimens (minimum)
- (b) If two types of tubing are to be qualified with the fittings:
 $31 \times 2 = 62$ specimens
- (c) If four sizes of fittings with two types of tubing are selected to present a typical cross-section of fittings to be produced:
 $62 \times 4 = 248$ specimens
- (d) If item (a) is a separable fitting (union) design with plans to test one size:
Requires $39 \times (1) = 39$ specimens (minimum)

- (e) If item (b) is a separable fitting to be qualified with two types of tubing, the test specimens required are:
 $39 \times 2 = 78$ specimens (minimum)
- (f) If item (e) is a separable fitting and it is desired to test four sizes with two types of tubing as representative samples of the total cross-section of fittings to be produced:
 $78 \times 4 = 312$ specimens (minimum)

If both permanent and separable fittings are to be qualified, then the various quantities would be additive:

$$\begin{aligned} a + d &= 70 \text{ specimens (minimum)} \\ b + e &= 140 \text{ specimens (minimum)} \\ c + f &= 560 \text{ specimens (minimum)} \end{aligned}$$

As can be seen, the quantity of fittings increases significantly when all parameters involved are included to properly qualify a new design.

VIII. TEST EQUIPMENT

During the review of many reference documents listed for use with a particular test, it was noted that the specifications (directly or indirectly) related to the required test equipment were either obsolete, inadequate or pertained primarily to tests for lower operating pressure type systems. Therefore, throughout this program, the documents noted in the RFQ were used as a guide for reference only and the SwRI Test Procedures and Test Sequences along with the Test Equipment were developed in order to produce more meaningful tests and test results using standard equipment/procedures where possible, thereby resulting in more repeatable data.

The equipment noted for each test procedure was developed in close coordination with the Design of the Test Specimens, Development of Test Procedures and Test Sequences, because each is interdependent on the other. Industry was also canvassed as to their "current" equipment and its applicability to the new 4,000 psi fitting requirement. One of the greatest problems voiced by industry was the many documents, containing many general requirements, currently in use for testing of tubing/fitting assemblies. Many of these documents are overlapping and a test facility need use only the one they feel fits their test or product to the best advantage. ARP 1185 (proposed) and ARP 1055 (being revised) are the two most direct and detailed tube testing specifications, but these too must have changes made to meet the up-to-date industry requirements. The equipment

designed by SwRI for this test program is presented in the form of drawings as an attachment to the previously discussed Test Procedures. The following comments are made to aid those who desire to fabricate their test equipment.

The repeated assembly test requires a suitable holding fixture attached to a solid base because of the high torque valves required for the -12 and larger fittings. A large smooth jaw vise is satisfactory if properly anchored. A calibrated torque wrench is required for each range of torque loads. Care must be exercised to insure that no lubrication exists on the threads or mating surfaces that will lead to an erroneous reading or a faulty seal.

The gaseous leakage test requires a "master leak-rate calibrator" if a mass spectrometer type leak detector is used, such as a Veeco 90A. Tests have proven that the gaseous leakage test, using the Veeco leak detector, produce superior results when compared to a proof pressure test with oil as the pressurizing media. For this reason, some of the "check" type operations before and/or after a test were changed to gaseous leakage rather than use of proof pressure. The other important factor in a gaseous leakage test is a small isolation chamber to surround the test fitting assembly. This chamber must also be used in the calibration. The entire gaseous leakage test depends on the operators ability to obtain a repeatable calibration. The gaseous leakage test is to be used as a "test" (GL_T)* on a new fitting or as a verification (GL_V)* check before

*See Figure 3

and after other tests to detect deterioration in the fitting/tubing assembly as a result of the specific test. For the purpose of these tests, "no leakage" is defined as a leakage rate of 1.0×10^{-3} sec/sec or less.

The Proof Pressure Test is applied as both a specific test on a new fitting (see combined proof and burst pressure test) or as a verification check before and after a specific test to determine if any deterioration resulted during the test. (See Gaseous Leakage Test)

The Burst Pressure Test is a destructive burst pressure test applied as both a specific test on a new fitting (see Combined Proof and Burst Pressure Test) or as a verification final check following a designated test to determine if any deterioration resulted from the test. In this manner, the degree of damage from each test can be assessed. Since the burst test is a destructive terminal test, it must be programmed accordingly. The same test chamber, if properly designed, can accommodate the gaseous leakage, proof and burst tests. Also, the chamber design and use may be combined with the impulse test requirements as shown in the test procedures.

The Impulse Test machine (Ref. MIL-F-18280C) has been subjected to considerable discussion lately due to the shape of the impulse curve versus the input pressure rise time or rate. According to the requirements of MIL-F-18280C, the pressure rise rate should be 180,000 psi/sec which produces a near vertical line with a sharp drop-off. This is also discussed in the section on Test Procedures. SwRI prefers the lower rise rate with a

longer dwell time at the peak pressure followed by a controlled drop-off. A pump, accumulator, intensifier, four-way valve and cyclic timer can easily produce the slower pressure rise rate to insure a longer duration peak pulse and therefore more energy at peak pressure into the test specimen. The pressure pulse trace can be obtained by using a visicorder or an oscilloscope photographic trace from the pressure transducer output.

The Rotary Flexure Test apparatus fabricated in accordance with the proposed ARP 1185 imposes some problems with test specimens because the majority of specimens (permanent or separable) are not perfectly straight. Therefore, when the zero reference bar is used to set the zero axis from the headstock to the tailstock, a perfectly true assembly should check out with the same accuracy. If the orbital base on the tailstock is adjusted to zero strain on both strain gages (located 90° apart) with zero displacement of the eccentric headstock, then a large difference in stress exists when the headstock eccentric is displaced for load. Caution should be exercised in fabricating the test specimens to insure linearity in the tube axis. Another problem area is the self-aligning bearing in the eccentric headstock wherein it is difficult to locate a heavy duty small size bearing that will do the job and last more than one run. Fittings such as unions should be tested with the complete assembly intact and the bosses should be tested as bosses with one-half anchored solidly to the tailstock. The strain gages should be located in the highest stressed area. The environmental chamber should be designed to encompass only the test fitting if possible and keep the

remainder of the test apparatus in the room temperature environment.

A larger self-aligning bearing can be used if size is of no importance.

The Assembly Torque and Misalignment Fixture utilized for separable fittings only, can be designed to serve a dual purpose since in both tests, one end of the specimen needs restraining and the pivot axis needs to be at the fitting joint. The length of the test specimen on the longer side where the misalignment is to be measured, determines the basic dimensions of the fixture. The misalignment offset scale should be marked in one-half degree increments. This fixture must also be securely anchored to a solid base because of the high torque values that must be applied to the assembly torque test. Proper strain gage installation and orientation as well as instrumentation readout is the key to good data on the torque test.

The Tube Restraint and Axial Pull fixture are identical, therefore the tests can be accomplished in the same setup in the tensile test machine. The one predominant factor is the problem of gripping the tube without slippage in order to reach tensile forces great enough to fail the tube or the fitting. An internal expanding sleeve helped solve the problem on the 21-6-9 and Titanium because the tube wall had a tendency to collapse at the higher loads required for the 21-6-9 and Titanium. The tapered grips and the tube end to fit into the grips both are sandblasted to obtain a higher friction coefficient. The tensile loads were applied with a 2000,000-lb BLH tensile test machine. The objective of this test is to prove the tensile strength and integrity of the tubing/fitting/joint.

The Thermal Shock Test utilizes the maximum and minimum temperatures to induce thermal shock in the test specimen. Both air shock and liquid shock are imposed by utilizing a hot and cold chamber alternately for the air shock followed by alternately filling of the tube with liquid at both temperature extremes under a minimum pressure. No special apparatus is required for these two shock tests. A separate oven and cold chamber are used to obtain the maximum shock rather than use a combination unit. Alcohol and dry ice are used for the low temperature liquid and hot oil is used for the high temperature liquid. Extreme caution must be used in handling both liquids and applying pressure to the test specimen.

The Immersion type Stress Corrosion Test apparatus is depicted in the test procedures, wherein the specimens are held rigid with induced bending while the pan of salt water raises and lowers to permit alternately dipping and drying at the prescribed temperatures. A reserve salt water tank is required to permit replenishment of the solution as it evaporates while operating at the elevated temperatures. Circulating fans were added to the chamber to speed up the drying process thereby necessitating a ventilating stack. The fixture is designed to preload the specimens to a predetermined stress. Strain gages can be installed to measure the strain.

The design and operation of the Fire Resistant Test Apparatus required many changes from ARP 1055 which is now undergoing a revision study. A propane burner was used with its standard nozzle and did not

require a special nozzle. The problem in design of this test apparatus is the various seals throughout the system that cannot operate at the elevated temperature with the 4,000 psi pump presenting the largest problem.

Therefore, a heat exchanger was added in the system just ahead of the pump with a heater installed just before the fluid reaches the test specimen in order to obtain the fluid inlet temperature of 200-230°F. The heat rise across the test specimen while in the 2,000°F flame will permit the downstream temperature to keep climbing during the five-minute test period.

Safety precautions used during these tests include a closed circuit TV monitor camera and a complete set of remote controls. The test setup is contained in a fire-proof/explosion-proof test cell.

The Structural Load Relaxation Test is commonly referred to as a "creep test" and is applicable only to separable fittings. The test apparatus consists of an environmental chamber to be set at 450°F with an internal fixture that is capable of holding the test specimen on one end and pre-loading (tension) mechanism on the other end. The initial strain is set after the tubes are conditioned in the chamber and the strain gages are monitored periodically to determine the amount of load relaxation caused by temperature and/or load or fitting/joint relaxation. The chamber and fixture permit pressurization of the fittings to 100 psi in order to detect a specimen failure.

The Vibration Test is conducted in accordance with MIL-STD-810B, Section 514, using a standard vibration exciter. The method of mounting

the test specimen on the shake table is a point that differs from one facility to another. There are two basic methods of mounting the specimen:

- Cantilever
- Two-point suspension (each end)

The major portion of industry conducts vibration tests on fittings using the cantilever method, and this same method is used in this series of tests on bosses only. The Institute feels that the cantilever test method is more applicable to the boss or terminating type fittings and the two-point suspension method more representative of in-line type fittings in an aircraft, such as unions, tees, elbows or crosses. If the shake table has a small capacity, use of the cantilever method may require the fabrication of a balanced type fixture that permits two specimens placed opposite each other. One specimen could be a dummy used for balance only. The pressurization system should be designed as lightweight as possible to prevent overloading the shaker table capacity. The unions in this program were tested using the two-point support system with rigid hard mounts throughout. The bosses were tested using the cantilever method on a single mount.

IX. TEST SPECIMEN DESIGN

The twelve groups listed in the test sequence require a different length or configuration of test specimen for each group in order to conserve test tubing. The primary reason for the many different designs relates to the type of data to be retrieved in each test versus the minimum length of tubing required for each test. Now that all of the equipment is designed and the specimen tests completed, it is obvious that by judicious design, two or three different sizes of test specimens could possibly suffice for all tests by wasting some tubing. A review of the test sequence chart provides some typical examples of the problems related to test specimen design as discussed in the following paragraphs.

Any size fitting could be used for the repeated assembly test. However, all fittings that are to receive a gaseous leakage test, proof pressure test and/or burst pressure test must be of such dimensions to permit installation in each of the required test chambers.

The length of the rotary flexure/fatigue test specimens is proportional to the spacing of the headstock and tailstock as well as the degree of eccentricity available in the head stock. If the spacing can be varied, the specimen length could be varied with diameter. Figure 3 of proposed ARP 1185 notes three types of test specimen setups for the rotary flexure machine and it is suggested that the drawings of ARP 1185 be changed as noted in Figure 3 to designate the difference between a test for "in-line fittings"

and "terminal or boss type fittings". In this manner the entire fitting is contained in the test whereas the method of testing noted in ARP 1185 would be applicable only to symmetrical in-line fittings because only one-half of the fitting is in the test. Distinction must be made between testing the fitting/tubing assembly or testing the interface, whether it be welded, brazed, swaged, or shrink type. If only the interface for permanent joints is undergoing tests, then the drawings shown in ARP 1185, Figure 3, are applicable. However, the method of attachment at the fixed-end is open for questioning because if the MS fitting is used to hold the end, it is already known that the MS fitting is inferior to the advance fittings being tested. Therefore, since the MS fitting is located at the highest stress point, it will fail first. SwRI prefers to use the more realistic method of testing a permanent fitting by clamping the tube to simulate a clamp or clamp block at a rigid point. Figure 2 of ARP 1185 illustrates an acceptable installation for testing boss-type fittings which requires a fixed-end separable fitting attachment. There are no drawings indicating how to set up separable joints for the rotary flexure test in ARP 1185.

A separable fitting, unless it is a boss, is normally used at a junction unless there is reason for a separable joint in a span or long run for assembly, production or maintenance reasons. Therefore, it would be more logical to test a separable fitting in its entirety by clamping the tube and testing the complete union with all interfaces and tubing each side, by supporting as indicated by the SwRI design. The length of the specimen can be varied

as required to fit the equipment providing sufficient displacement is available to obtain the required stress at the strain gage location.

The design of the test specimen for the Impulse Test parallels that of the Proof Pressure Test, Burst Pressure Test or Gaseous Leakage Test because the same chamber and manifold design is used for all four tests. Therefore, the test specimens would necessarily be the same length and/or design.

The Assembly Torque and Misalignment Test could be the same length as other selected specimens except that it was determined that the Misalignment Test half of the tube assembly should approach the average frame spacing in an aircraft and permit the tube a small degree of deflection rather than be completely rigid.

The Stress Corrosion and Thermal Shock test specimen design once again is a function of the fixture design that holds and preloads the assembly. Also, the larger the specimen, the larger the fixture and the larger the immergeable tank system. Therefore, an optimum size specimen design was selected. This test specimen can be of any size that could be compatible with other sizes in order to develop a standard set of test specimens.

The Axial Pull and Tube Restraint Test specimen is loaded in tension for both tests. The tensile load is applied by the BLH tensile load test machine for both tests and the same set of end grips are used for both tests. Once again the specimen length is not critical and could be made to match other sizes as long as it will fit the tensile test machine that is available.

The length of the Vibration Test specimens is applicable to separable fittings only and was computed to furnish the optimum vibration spectrum; however, due to the range of frequencies involved, several lengths could be used, except the "g" loading becomes excessive in the longer specimens. The lengths specified herein furnished excellent data and if correlatable results are desired these lengths should be used. Also, the type of holding fixture and pressurization system for the shaker table setup will affect the overall length of the specimen. The facility that accomplishes the vibration test should be consulted before designing the test specimen.

The Fire Resistance Test specimen is designed to fit the fire test apparatus which has certain requirements that necessitates a long specimen as can be seen from the test procedure schematic drawings. It is not likely that the length of this test specimen would match any others.

The Structural Load Relaxation Test specimen is applicable to separable fittings only and is designed to meet the fixture dimensions. The fixture dimensions can be designed to any specimen size desired, but the number of test positions would probably dictate the size of the environmental chamber.

Two critical items common to many of the test specimens are the method of clamping and holding or supporting the specimens for longitudinal loads and the type of end-fittings to be utilized for the tests that require high pressure. For tensile tests, the tubing can be most efficiently clamped by using tapered-jaw blocks with an expanding internal plug to keep the tube

walls from collapsing. The rotary flexure, assembly torque and misalignments and vibration tests can utilize adapter bushings so that one clamp block will suffice. The problem of end fittings becomes rather costly if the same test fitting is used in the middle as a specimen and on the ends of the test specimen. Also, these fittings usually need to be adaptable for a pressure inlet or be used as a cap or plug. The most critical test is burst pressure followed by impulse and rotary flexure. Several standard swage type end fittings are available on the market and will usually suffice for some portions of the tests. For the critical tests noted above, special fittings will have to be installed. In other words, the end fittings have to be as good (or better) than the test fitting. Satisfactory results were obtained by using the Swagelok end fittings on the 304 1/8 H tube and using Harrison HMS fittings throughout on the 21-6-9 and Titanium tubing for the higher pressure specimens.

Table 3 presents the summary of test specimen assembly sizes and lengths for permanent fittings as used in this program. Table 3 also presents the summary of test specimen assembly sizes and lengths for separable fittings as used in this program. Table 4 presents the summary of test specimen sizes and lengths for boss type test specimens as used in this program.

TABLE 3

TYPICAL SIZES FOR PERMANENT AND SEPARABLE
TYPE FITTING TEST SPECIMENS

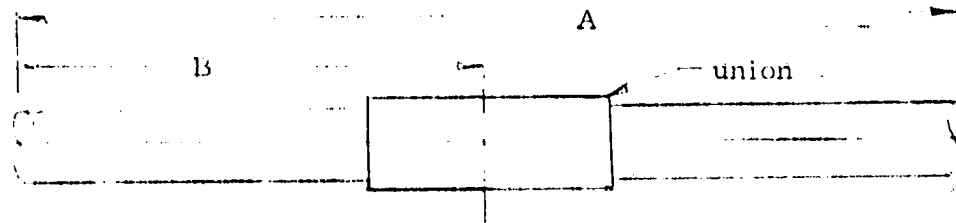

Test Sequence	Permanent Dimensions (in.)		No. Req'd. Assy's.	Separable Dimensions (in.)		No. Req'd. Assy's.
	A	B		A	B	
<u>-6 Size:</u>						
I, II, VI	14-3/4	7-3/8	8	14-3/4	7-3/8	6
III, IV, V	18-1/4	5-3/4	18	18-1/4	5-3/4	18
VII	18-1/2	5-1/2	2			-
VIII	12-1/4	4-1/2	3	12-1/4	4-1/2	3
IX	23-1/4	11-5/8	2	23-1/4	11-5/8	2
X	11	5-1/2	2			-
XI	17-1/4	8-5/8	2	17-1/4	8-5/8	2
XII	14-1/4	7-1/8	2			-
<u>-10 Size:</u>						
I, II, VI	15	7-1/2	8	15	7-1/2	6
III, IV, V	18-3/4	7-1/2	18	18-3/4	7-1/2	18
VII	19-1/4	5-3/4	2			-
VIII	12-1/2	4-1/2	3	12-1/2	4-1/2	3
IX	24	12	2	24	12	2
X	13	6-1/2	2			-
XI	17-1/2	8-3/4	2	17-1/2	8-3/4	2
XII	15	7-1/2	2			-
<u>-16 Size:</u>						
I, II, VI	15	7-1/2	8	15	7-1/2	6
III, IV, V	18-3/4	9-1/2	18	18-3/4	9-1/2	18
VII	19-3/4	5-3/4	2			-
VIII	12-3/4	4-1/2	3	12-3/4	4-1/2	3
IX	24-1/2	12-1/4	2	24-1/2	12-1/4	2
X	15	7-1/2	2			-
XI	18-1/2	9-1/4	2	18-1/2	9-1/4	2
XII	15-1/2	7-3/4	2			-

TABLE 4

TYPICAL SIZES FOR BOSS TYPE FITTING TEST SPECIMENS

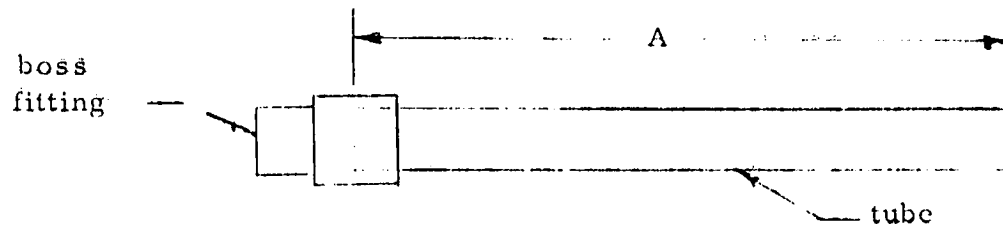

<u>Test Sequence</u>	<u>Type Tubing</u>	<u>Tube Size</u>	<u>Type Fitting</u>	<u>Length "A"</u>	<u>No. Req'd.</u>
I, II, VI	titanium	-6	boss	7	8
III, IV, V	titanium	-6	boss	7-1/2	18
VII	titanium	-6	boss	13-1/2	2
VIII	titanium	-6	boss	11-3/4	3
IX	titanium	-6	boss	11-3/8	2
X	titanium	-6	boss	4-1/2	2
XI	titanium	-6	boss	8-1/2	2
XII	titanium	-6	boss	7	2
I, II, VI	titanium	-10	boss	7-1/4	8
III, IV, V	titanium	-10	boss	9-1/2	18
VII	titanium	-10	boss	13-1/2	2
VIII	titanium	-10	boss	11-7/8	3
IX	titanium	-10	boss	11-3/4	2
X	titanium	-10	boss	5	2
XI	titanium	-10	boss	8-1/2	2
XII	titanium	-10	boss	7-1/4	2
I, II, VI	titanium	-16	boss	7-3/8	8
III, IV, V	titanium	-16	boss	12 -	18
VII	titanium	-16	boss	13-1/2	2
VIII	titanium	-16	boss	12-1/4	3
IX	titanium	-16	boss	11-7/8	2
X	titanium	-16	boss	6-5/8	2
XI	titanium	-16	boss	8-7/8	2
XII	titanium	-16	boss	7-3/8	2

X. TEST TUBING

The program is divided into the following sections with respect to the tubing to be tested:

- 304 1/8 hard CRES (used with MS fittings only) (MIL-T-6845)
- Armco 21-6-9 CRES (BMS-7-185 or DMS-1944B)
- 3Al-2.5V Titanium (BMS-7-234 Rev. A)

The required wall thicknesses for the test specimens of three types of tubing were computed based on the available mechanical properties and then the nearest standard wall thickness was selected. The tubing manufacturers will produce the tubing wall thickness to any specification desired, however SwRI preferred to use nominal standards as used in the past. Table 5 presents the computed and selected wall thicknesses.

The 304 1/8 H CRES tubing (MIL-T-6845) is listed as a Class II tubing and was used with MS flareless separable type fittings only as baseline data. The assemblies received the full sequence of tests for separable fittings. NDI processing was not applied to the 304 1/8 H Class II tubing because the reliability factor is so high on this type of tubing after the many years of production. The 304 1/8 H CRES tubing was ordered to the MIL-T-6845 specifications.

The Armco 21-6-9 CRES tubing is listed as a Class I tubing and was assembled/tested with both permanent and separable type fittings of various designs as well as bosses. The two types of fitting/tubing assemblies received the full sequence of tests scheduled for each category. The 21-6-9

TABLE 5
 TEST TUBING WALL THICKNESSES (NOMINAL)

	<u>-6</u>	<u>-10</u>	<u>-16</u>
304 1/8 hard CRES	.024"	.041"	.065"
Armco 21-6-9 CRES	.024	.040	.064
3 Al-2.5V Titanium	.027/.030	.045/.050	.072/.080

tubing received two NDI's; one at the Bishop Tube Company and one at SwRI to verify the absence of flaws or defects as required by the specification. The 21-6-9 tubing was ordered to either the Boeing or Douglas Specifications BMS-7-185 or DMS-1944B.

The 3AL-2.5V titanium tubing was listed as a Class I tubing and was assembled/tested with both permanent and separable fittings of various designs. The two types of fitting/tubing assemblies received the full sequence of tests scheduled for each category. The 3AL-2.5V tubing received the same two ultrasonic inspections (NDI) that the 21-6-9 tubing received; one at Bishop Tube Company and one at SwRI. The tubing failures are inspected for the presence of flaws that were not picked up during the ultrasonic inspection. The 3AL-2.5V Ti tubing was ordered to the Boeing Specification BMS-7-234, Revision A.

Tubing NDI

The 21-6-9 and the 3AL-2.5V tubing was inspected by the tubing manufacturer using ultrasonic equipment setup to handle twenty-foot tubing lengths. Recent developments by the transducer manufacturer has significantly advanced the state-of-the-art and the only problem is the fabrication of the processing facility as explained in the following paragraphs.

The ultrasonic inspection of the tubing was performed using a system whereby the tube is immersed in water, then rotated while the transducer is moved along a track parallel to the tube axis. The equipment required to perform the inspection via method two consists of an

Automation Reflectoscope UM-721 with pulse-receiver unit 10 sdb, and a fast transgate plug-in unit, used with a type J. FM 10 Mhz SIZ medium focus transducer, 1/2" diameter. This setup provides for a flaw resolution of 0.005 in.

A Bug-O-Track and Mark II drive unit is used to accurately move the transducer the length of the tube while the tube is rotated by a separate power source. A Micro-Mini-Manipulator, manufactured by Automation, Inc., is used to accurately position and move the immersion transducer, in the required axes. If a flaw of significant magnitude is detected (which is pre-set according to required standards), an alarm is activated to alert the operator and simultaneously turn off all tubing movement as well as transducer movement. The operator then marks the suspect area for detailed mapping and/or flaw characterization. Double and triple probe-mounted automated systems are employed if time is a factor and defects are checked simultaneously. The flaws are characterized as longitudinal (parallel to tube axis), circumferential (90° to tube axis) and herringbone (45° to tube axis). A test tube master flaw indicator is fabricated with controlled and known depth of induced flaws for all three patterns. This test tube is used to calibrate the system for all three axes and is also used to set the level for the system to trip the alarm.

The SST titanium tubing received an ultrasonic inspection by Zirtex and two ultrasonic inspections by Boeing. The 21-6-9 tubing received an ultrasonic inspection by Bishop Tube and was also ultrasonically

- 3 -

inspected by SwRI. The titanium tubing from Bishop tube also received ultrasonic inspection after fabrication and when received by SwRI.

The trigger level for flaw detection was set at .002" depth with the flaw surface dimensions maximum as .020 x .060. A nominal amount of tubing was rejected by SwRI using these limits and it was impossible to determine the percentages of rejection by Bishop Tube. The 3Al-2.5V Ti purchased from Bishop Tube was specified to contain texture control and since the Boeing SST tubing was not texture controlled a marked difference should appear in the data between the two types of finish according to tests conducted by Boeing. Separate identification was made for each type of tubing in order to determine the significance of the texture control finish. In some test tubing specimens, superficial scratches were installed to determine the level of Q. C. inspection by each vendor's facility. Some vendor's Q. C. caught the defects while others did not.

XI. MS FITTING - BASELINE DATA

In the past, many individual tests have been conducted on the MS flareless fitting with a minimum of documentation. The MS flareless fitting was accepted as a standard for a number of years because flared tube joints presented a critical problem with the flaring of the higher strength material. The MS flareless fittings surpassed the AN flared fitting in all tests as it should at the 3000 psi operating pressures because the MS series fitting is highly overdesigned as has been proven by Lockheed Aircraft at Burbank. The redesigned MS fittings by Lockheed reduced the weight of a fitting assembly and the margins of safety are still adequate for a 3000-psi system. These redesigned MS fittings were not used as a baseline reference in this program, however. Only the standard MS fittings were used and they consisted of:

MS 21921	Nut
MS 21922	Sleeve
MS 21902	Union

All MS fittings were assembled with precise X-control using the Weatherhead tools for presetting the sleeves. The test specimens were made up in the same length as the test specimens submitted by all vendors for the various tests in order that the resulting baseline data be compatible with the data from the same tests on each vendor's design. This has been the problem in correlating data from the previous tests because a minor change in the test procedure or specimen design can produce a significant

change in the results. Therefore, we have one of the primary reasons for development of a testing standard with detail specifications covering the specimen design, equipment design and operational or test procedures.

The MS union is considered as a separable fitting and the minimum quantity of test specimens required is 39 for this program. The test procedures for each test contain a recommended minimum number of specimens for qualification testing of fitting/tubing assemblies.

The MS assemblies were tested as Class II fittings using the following parameters:

Temperature: -65°F to +275°F
 Operating Pressure: 3,000 psi
 Proof Pressure: 6,000 psi
 Min. Burst Pressure: 12,000 psi

Each test procedure lists the applicable test parameters for Class I and Class II fittings. Due to the oversized configuration of the MS fitting, very few failures were anticipated with the Class II parameters and appropriate tests. The MS separable fitting assemblies received the following series of tests using the noted references as a guide:

Test	Reference
*1. Repeated Assembly	MIL-F18280-C
2. Proof Pressure	ARP-899
3. Burst Pressure	ARP-899
4. Combined Proof and Burst Pressure	ARP-899
5. Impulse	MIL-F18280-C
*6. Assembly Torque and Misalignment	SwRI
*7. Axial Pull and *Tube Restraint	SwRI
*8. Structural Load Relaxation	SwRI

*Applicable to separable fittings only

Test	Reference
9. Gaseous Leakage	ARP-899
10. Fire Resistance	ARP-1055
11. Thermal Shock	ARP-899
12. Stress Corrosion	ARP-899; FTS-151
*13. Vibration	MIL-F18280-C
14. Rotary Flexure and Fatigue— —	MIL-STD-810B
	MIL-F-18280-C

Under "References", if no standard existed for the particular test to use as a guide, Southwest Research and ASD jointly agreed on the recommended procedure.

Carbon steel MS sleeves and nuts were used in the test specimen assemblies, knowing that the stress corrosion test would be rather severe on this combination. The test results on the MS fittings are contained in a separate volume of this series and are made public information.

The complete MS fitting test program and results are assembled in a separate report entitled: "Baseline Data from Tests Conducted on Standard MS Tube Fittings", and is available from the ASD/ENJPH project office.

*Applicable to separable fittings only

XII. SUMMARY

Due to a curtailment of funds, the total program could not be completed at this time. Every effort will be made to secure funds to complete testing of the remaining test specimens or at least the more critical or important tests. The foregoing sections present the general overall program with the exception of the test data. Only the final report on the MS fitting baseline data contains the results of the test data because this is public information available to everyone. The data generated from the various types of fittings will not be disseminated to the public and only the vendors will receive copies of the data pertaining to their own fittings. Any one desiring copies of the test data resulting from this test program will be referred to the particular vendor in question. If the vendor wants that particular data made available, then he has the right to do so. No one but ASD will have a copy of the total data package and this will be for their own internal use.

As previously explained, there was no winner picked as a result of this test program. The fittings were simply purchased and evaluated under identical conditions so that a true comparison and evaluation could be made. For this reason, the MS fitting was tested to be used as baseline data since the MS fitting is still a reliable fitting (though heavy) for 3000 psi systems. If funds are acquired to complete testing of the remaining specimens, only the attached data sheets will be revised by additional data points.

There is no analysis or critique of the test results included in the _____ attached data summaries. It was agreed that each vendor could take the data applicable to his fittings and analyze it any way that best suits the use for which it is intended. The tests that are considered as destructive will have comments as to where and what type of failure was generated. All other specimen tests are accompanied by comments and data from which an analyses/summary can be generated.

Any technical questions concerning this report and data contained herein can be directed to the project monitor at ASD/ENJPH, Mr. Ray Hess (513/255-5229) or to the contract project manager, Mr. C. R. Ursell at Southwest Research Institute in San Antonio, Texas (512/684-5111). The test machinery and equipment used in this program will remain intact at Southwest Research for use by fitting manufacturers to obtain test data that can be used in direct correlation with the test results attached to this report.

XIII. REFERENCES

Military Specifications

MIL-F-18280 Fitting, Flareless Tube, Fluid Connection
 MIL-F-5509 Fittings, Flared Tube, Fluid Connection
 MIL-F-27417 Fittings, Rocket Engine, Fluid Connection

Military Standards

MS 33649 Bosses, Fluid Connection - Internal Straight Thread
 MS 33566 Fitting, Installation of Flareless Tube - Straight Threaded Connector
 AND 10064 Fitting, Installation of Flared Tube, Straight Threaded Connectors
 MIL-STD-810 Environmental Test Methods

NASA Specifications

KSC-F-124 Fittings/Pressure Connections/Flared Tube
 MSFC-SPEC-143 Fittings, Flared Tube/Premium Quality/Pressure Connections,
 Specifications for

Industry Specifications

ARP 899 Connectors and Connections, Fluid System - Permanent Type
 ARP 1055 (Proposed) Fire Resistance and Fire Test Requirements for Fluid
 System Components
 ARP 603 Impulse Test Equipment for Testing Hydraulic System Components
 ARP 1185 (Proposed) Flexure Testing of Hydraulic Tubing, Joints and Fittings

Technical Reports

AFAPL-TR-69-67 Titanium 6AL-4V Hydraulic Plumbing for Advanced Aero-
 space Vehicles
 AF RPL-TR-65-161 Exploratory Development Work on Families of Welded
 Fittings for Rocket Fluid Systems
 RPL TDR 64-24 Applied Research and Development on Families of Brazed
 and Welded Fittings for Rocket Propulsion Fluid Systems
 AERPL TR 65-162 Development of AFRPL Threaded Fittings for Rocket
 Fluid Systems
 RTD TDR 63-1115 Development of Mechanical Fittings - Phases I and II
 ASD TR 61-483 Metallic Boss Seal Evaluation and Test Program
 RPL TDR 64-25 Aerospace Fluid Component Designers Handbook Vols 1 & 2
 NA 60-648 Evaluation of AM 350 CRES Hydraulic Tubing and LD 273-0001
 Union - Brazed Tube for 4000 PSIG Hydraulic Systems Applicable
 to SB-70 Airplane

WADC TR 59-267 Hydraulic and Pneumatic Fitting and Tubing Test Program

WADC TR 55-163 Testing of Metal Boss Seals

NASA-Tech Brief 71-10266. - Aug. 1971. Criteria for Vibration Testing

NASA-CR-91356(N68-12955) The Study of Mechanical Shock Spectra for
Spacecraft Applications.

DOT-FA-SS-71-12 Titanium Tubing and Fittings.. The Boeing Co.
(Texture Control Tubing Tests)