

General Disclaimer

One or more of the Following Statements may affect this Document

- This document has been reproduced from the best copy furnished by the organizational source. It is being released in the interest of making available as much information as possible.
- This document may contain data, which exceeds the sheet parameters. It was furnished in this condition by the organizational source and is the best copy available.
- This document may contain tone-on-tone or color graphs, charts and/or pictures, which have been reproduced in black and white.
- This document is paginated as submitted by the original source.
- Portions of this document are not fully legible due to the historical nature of some of the material. However, it is the best reproduction available from the original submission.

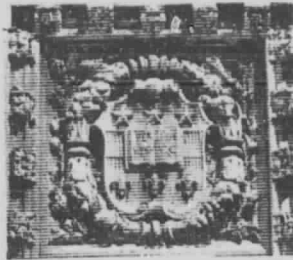

WASHINGTON UNIVERSITY

(NASA-CR-143330) ALTERNATIVE COMMUNICATION NETWORK DESIGNS FOR AN OPERATIONAL PLATO 4 CAI SYSTEM (Washington Univ.) 25 p HC \$3.25 CACL 17B N75-30386
Unclas 33041
G3/32

CENTER FOR DEVELOPMENT TECHNOLOGY

REPORT No. CDTCG-R(T)-75/3

AUGUST, 1975

ALTERNATIVE COMMUNICATION NETWORK DESIGNS FOR AN OPERATIONAL PLATO IV CAI SYSTEM

ROBERT E. MORLEY, JR.
LESTER F. EASTWOOD, JR.



ABSTRACT

This memorandum designs and compares the cost of alternative communications networks for the dissemination of PLATO IV computer-aided instruction. Four communication techniques are compared: leased telephone lines, satellite communication, UHF TV, and low-power microwave radio. For each network design, costs per student contact hour are computed. These costs are derived as functions of student population density, a parameter which can be calculated from census data for one potential market for CAI, the public primary and secondary schools. Thus, calculating costs in this way allows us to determine which of the four communications alternatives can serve this market least expensively for any given area in the U.S. The analysis indicates that radio distribution techniques are cost optimum over a wide range of conditions.

TABLE OF CONTENTS

No.		Page
1.	Purpose and Scope of The Study.	1
1.1	Introductory Remarks	3
1.2	Organization	3
2.	The Communication System of the PLATO IV CAI Project.	5
2.1	Introduction	5
2.2	PLATO Terminal Communications Requirements	5
2.3	The PLATO Communications System Control Devices.	5
2.4	CPU and NIU Characteristics.	9
2.5	Present PLATO Communication Configuration.	11
2.5.1	Communications With Local Terminals	11
2.5.2	Telephone Communications for Remotely Located Terminals	13
2.5.3	Microwave Radio Communications for Terminals in the Urbana Area.	14
2.5.4	Cost Comparison: Microwave vs. Telephone for the Urbana Area	15
2.6	Operational Capacity of PLATO IV	16
3.	Distribution of PLATO IV Over Leased Telephone Lines.	19
3.1	Method of Analysis	19
3.2	Description of Telephone Services and Hardware Devices.	19
3.3	Costs for Example Configurations	27
3.3.1	Configurations Using LDSU's	27
3.3.1.1	One Terminal Link.	27
3.3.1.2	Many Terminal, LDSU Link	27
3.3.2	Configurations Using Modems	30
3.4	Summary of Phone System Design Methodology	35

TABLE OF CONTENTS
(continued)

No.		Page
3.5	Network Design Examples.	35
	3.5.1 LDSU Link Example	35
	3.5.2 Modem Link Example.	39
4.	PLATO IV CAI Delivered By Satellite	40
	4.1 Introduction	40
	4.2 Satellite System Design and Costing Methodology.	41
	4.2.1 Description of the Modified STAMP Program	41
	4.2.2 General Design Methodology.	43
	4.3 Design Examples.	47
	4.3.1 Description of System Coverage Model.	47
	4.3.2 Hybrid System (Satellite and Phone Lines)	54
	4.3.3 Two Way Satellite System Design	60
	4.4 Summary and Conclusions.	66
5.	Radio Distribution of PLATO IV.	67
	5.1 Introduction	67
	5.2 Presently Available Radio Broadcast Technologies	67
	5.2.1 Broadcast UHF Television.	67
	5.2.2 Omni-Directional Microwave Broadcast.	69
	5.3 Two Network Designs for PLATO Delivery	70
	5.3.1 Network Employing UHF TV Broadcast.	71
	5.3.1.1 Forward Channel Equipment.	71
	5.3.1.2 Return Channel Requirements and Equipment.	74
	5.3.1.3 Channel Allocation from the FCC.	76
	5.3.1.4 UHF TV System Cost	77
	5.3.2 Network Employing Microwave Broadcast	78

TABLE OF CONTENTS
(continued)

No.		Page
5.4	Comparison of UHF TV and Microwave Systems	81
5.5	Conclusions.	88
6.	Comparison of Phone, Satellite and Radio Systems.	91
6.1	Introduction: Method of Comparison.	91
6.2	Relating Communications Costs to Student Population Density.	93
6.3	System Comparisons	99
6.4	Sensitivity Analysis	103
6.4.1	Variation of Systems Cost with Number of Terminals Per School.	103
6.4.2	Variation of Relative Cost Comparisons with Radio Systems' Ranges	107
6.5	Modifications to Enhance Efficiency.	107
7.	Conclusions	111
8.	Bibliography.	115

LIST OF TABLES

No.		Page
2.1	Communications Specifications for PLATO IV User Terminals and Site Controllers.	10
2.2	Communication Specifications for PLATO IV NIU and CPU . . .	10
2.3	Summary of PLATO IV Communications Costs.	17
3.1	a) AT&T Monthly Charges for Intra-State Leased Lines. . . .	21
	b) Additional AT&T Charges.	21
3.2	Data Communications Devices Offered by the Codex Corporation	25
3.3	Costs for One Terminal LDSU Link.	28
3.4	Costs for LDSU and Mudex Link	29
3.5	Costs for Link Employing 4800 B/S Modems and Mudexes. . . .	32
3.6	Costs for Link Employing 960C B/S Modems and Eight-Channel Mudex	33
4.1	Price Changes for STAMP	45
4.2	Statistical Summary of States to be Served by Satellite System.	49
4.3	Design Summary for Hybrid System.	61
4.4	Design Summary for Two-Way Satellite System	62
6.1	Computed Values of Average Number of Students/School and Student Population Density for the U.S.	95

LIST OF FIGURES

No.	Page
2.1 PLATO IV Equipment Configuration.	6
2.2 Examples of Present PLATO IV Network.	12
3.1 Communication Configurations Using Codex Equipment.	26
3.2 Comparison of Costs/S.C.H. for n Terminals Per Site; LDSU's Versus LDSU's and Mudexes.	31
3.3 Decision Regions as Functions of Number of Users Per Line (n) and Distance Between Remote Site and Computer.	36
3.4 Costs of Optional Configuration for n = 8.	37
4.1 STAMP Block Diagram	42
4.2 Flow Diagram of STAMP	44
4.3 The United States by Rural Student Population Density (RSPD).	48
4.4 Satellite Beam 3dB Footprints	52
4.5 Approximate Coverage Model for Each of the 7 Beams.	53
4.6 Configuration of Hybrid System.	56
4.7 Computer Output of Ground Station Design for Hybrid System.	57
4.8 Computer Output of Satellite Design for Hybrid System	59
4.9 Computer Output of Ground Station Design for Pure Satellite System.	64
4.10 Computer Output of Satellite Design for Pure Satellite System.	65
5.1 Equipment at a) Computer and b) School Sites for UHF TV Broadcast System.	72
5.2 Equipment at a) Computer and b) School Sites for Microwave Broadcast System.	79
5.3 Communication Costs of UHF TV and Microwave Systems (L = 5 years)	82
5.4 Antenna Patterns for Extended Coverage Systems.	83

LIST OF FIGURES
(continued)

No.	Page
5.5 Extended Coverage Equipment Configuration	84
5.6 Costs of UHF TV and Extended Microwave Systems (Radius = 70 miles. L = 5)	87
5.7 Costs of Extended UHF TV and Triply Extended Microwave Systems (Radius = 140 miles, L = 5 years)	89
6.1 Plot of Number of Students/School vs. Log_{10} (SPD)	98
6.2 Costs of Phone, Satellite and Radio Systems vs. SPD	101
6.3 SPD and Rural SPD for the U.S.	104
6.4 Communications Costs for All Systems with 504 Schools/ PLATO IV System	105
6.5 Communications Costs for All Systems with Radio Systems' Ranges Halved	108

ALTERNATIVE NETWORK DESIGNS FOR AN OPERATIONAL PLATO IV CAI SYSTEM

1. PURPOSE AND SCOPE OF THE STUDY

1.1 INTRODUCTORY REMARKS

The purpose of our research is to design and evaluate communications networking schemes for distributing computer-aided instruction (CAI). We consider four alternative communications techniques - 1) leased telephone lines, 2) satellites, and 3) microwave or 4) UHF radio. We evaluate the cost of each proposed scheme in dollars per student contact hour, and based on this evaluation, we show how to decide on a best method for distribution. This decision depends on the distance of the CAI site from the central computer and on the number of terminals at the site.

In order to guarantee that our problem is well-defined, we propose two important constraints on our design work. First, we use the PLATO IV system developed at the University of Illinois (1)* as the example CAI system in our analysis. Second, we consider the specific problem of delivering PLATO IV CAI to public primary and secondary schools.

*The numbers in parentheses in the text indicate references in the Bibliography.

We believe that these constraints, while making the problem we solve a realistic one, will not restrict the generality of our results.

PLATO IV serves our needs well as an example for analysis. Its characteristics are, we believe, likely to be representative of those of future, large CAI systems. Moreover, its communications needs could be served by a host of different networking schemes, so our analysis should not be restricted in its generality by quirks of the system.

Our second constraint, the choice of public primary and secondary schools as our market, also gives our research a realistic basis, but does not excessively restrict the generality of our results. The public school system is a large and demographically diverse market; there are almost 50 million students in public primary and secondary schools,* and they live both in crowded cities and in sparsely populated rural areas. Thus the public school system is large enough to justify the development of a CAI system and diverse enough in density to require many alternative schemes for CAI distribution.

The quantitative measure to be used in comparing various communications methods is the cost of communications per student contact hour (S.C.H.), calculated as the cost of communications per month divided by the number of student contact hours per month. Cost per S.C.H. has been used as an efficiency indicator by other researchers (2, 3) because this measure facilitates comparison of costs with traditional educational systems. Although costs per S.C.H. can be compared for CAI and traditional education it is difficult quantitatively to compare the effectiveness of one hour of each type of

*Hereafter any reference to schools means a public primary or secondary school.

instruction. (4) However, studies to date (4, 5) indicate that CAI can be significantly more effective than traditional educational methods. Thus computing costs per S.C.H. aids in comparison but does not insure a common basis for comparison in regards to overall quality of learning. An analysis of the inherent educational content of CAI and traditional education systems is beyond the scope of this study.

1.2 ORGANIZATION

Chapter 2 describes the PLATO IV CAI system's present configuration with special emphasis on the communications methods employed to send data to, and receive it from, remote sites. The chapter reports the communications costs for the techniques now used and offers an argument for increasing system capacity from 1008 active terminals per system for the present experimental system to 4032 active terminals for operational systems.

Chapter 3 presents an analysis of leased telephone line distribution systems for PLATO IV. It describes, and computes the prices for, various phone company services and devices. We demonstrate that systems costs are functions of the number of terminals at each remote site and the distance from the remote site to the central computer. We then indicate optimum network configurations for various possible terminal distributions.

Chapter 4 discusses how satellites can be used to distribute PLATO IV's data. We propose two systems for satellite delivery to schools. The first employs a satellite link in the forward (computer to user) channel and uses phone lines in the return (user to computer) channel. The second employs satellite channels in both directions. Systems are

costed and characteristics unique to satellite distribution, such as propagation delay of data, are discussed.

Chapter 5 presents two radio broadcast techniques for satisfying PLATO's communications requirements. These are UHF TV and omnidirectional microwave broadcast. Chapter 5 also presents a description of how repeaters can be used to extend the systems' ranges. We present costs that are functions of the number of remote sites and of the extent of repeater use for range extension.

By adding maintenance and equipment costs, Chapter 6 adjusts the costs derived in Chapters 3 through 5 so that they can be compared. We propose student population density as a basis for comparison that lends itself to easy use as a predictor of the most economical communication technique and we transform all costs into functions of this user parameter. We then point out areas of applicability for the various technologies on a map of the United States based on the average student population densities computed for each state. Chapter 6 also indicates a few possible modifications to the PLATO IV communications systems that would increase reliability and decrease costs.

2. THE COMMUNICATION SYSTEM OF THE PLATO IV CAI PROJECT

2.1 INTRODUCTION

PLATO IV is a CAI system, developed at the University of Illinois-Champaign, capable of interacting with as many as 1008 user terminals simultaneously. (6) Students at the PLATO terminals are able to receive individualized instruction at a rate which is determined by their learning capabilities. Courses range from basic mathematics and English grammar to continuing education for professionals.

PLATO IV is a good example of a large computer aided instruction system. Hence it was chosen for our study of communications techniques for the distribution of large CAI systems. This chapter presents a technical description of the PLATO IV system in terms of communications needs, present methods of satisfying those needs, and the associated costs.

2.2 PLATO TERMINAL COMMUNICATIONS REQUIREMENTS

User terminals are capable of writing 180 characters per second or 60 connected lines per second. (7) The device can display 32 lines of 64 characters. A random-access image selector can project any one of 256 full-color images onto the transparent plasma panel while it is displaying alpha-numeric and graphic information. A random access audio device records on, and plays back from, an interchangeable 15 inch disk which holds up to 20 minutes of recorded messages. Thus the terminal offers instruction through a wide variety of educational media.

2.3 THE PLATO COMMUNICATIONS SYSTEM CONTROL DEVICES

Figure 2.1 (7) is a block diagram of the PLATO IV system. The large central computer is a Control Data Corporation "Cyber 73." Two of its

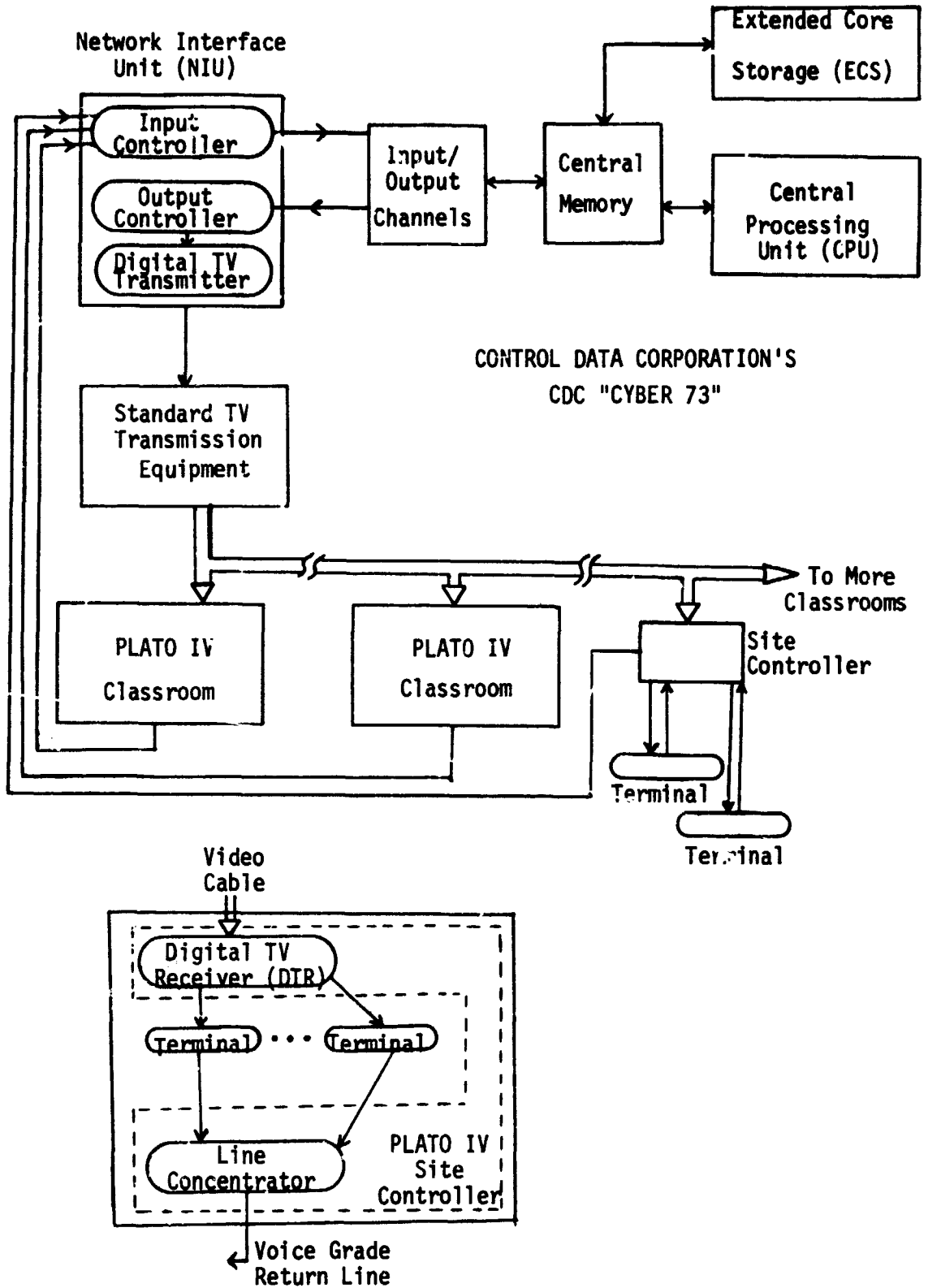

Figure 2.1: PLATO IV Equipment Configuration (7)

12 input/output channels converse with the PLATO IV Network Interface Unit (NIU) while others control the various peripheral devices (printer, disks, magnetic tape etc.). The NIU consists of an input controller, an output controller and a digital television transmitter (DTX).

The input controller polls all incoming lines from the PLATO network for the presence of data. Once data is received, the input controller tags it with a site address, checks parity, and passes it on to the computer via the I/O channel.

The output controller accepts data from the computer and readies it for transmission over the PLATO network to the designated user. The output controller delivers data to the DTX, where the data is encoded into a format compatible with standard commercial television equipment (8) for transmission over a suitable communications channel to the site controllers. One NIU is capable of serving 1008 active terminals.

As seen in Figure 2.1, the site controller contains a digital television receiver (DTR), a distributor, and a line concentrator. The original design placed the site controllers at the remote user classrooms. Because difficulties have been encountered in acquiring wide band data service necessary to feed remote site controllers, the site controllers are placed at the computer site, contrary to original plans.

The site controller's three components can be categorized according to their functions. The DTR and distributor are for computer to user communications while the concentrator is for user to computer communications. The DTR recovers data from the TV signal for the 32 users it serves and distributes it to the appropriate users. The

line concentrator transmits data from as many as 32 users to the computer over a single low data rate (4800 B/S) communications channel. Since a site controller serves 32 users' terminals, there are 32 site controllers in a system with the maximum number of users (1008).

Communications between the user terminals and the computer take place over two independent channels. One is a high data rate channel for transmission of data to the terminals, while the other is a lower data rate channel for the transmission of user's requests and responses in the reverse direction, to the computer. The data transmission rates needed in the forward (computer to user) and reverse (user to computer) channels have been set by considering individual user demand statistics.

The user terminal is able to receive and write on the display at a rate of 720 words per minute, a fairly high user reading rate. To achieve this writing rate, 1260 bits of data per second must be sent to the terminal.

The reverse channel data rate can be set by assuming that all 1008 users are sharing the communication lines equally. Setting the individual rates at an acceptable level for this worst case guarantees good system performance. It has been the experience of the PLATO system designers that the minimum acceptable typing rate for an experienced typist is roughly 60 wpm. (6) At 17 bits per character, 5 characters per word, and 32 users per site controller, this requirement dictates a data rate out of the concentrator of 2,720 bits per second (B/S). This return capacity would be adequate if users could be limited to a burst typing rate of 60 wpm. However, when typing the word, "the," for example, a typist enters data at a rate above his or her

average rate of 60 wpm. Therefore, it was empirically decided that average rates of nearly 100 wpm should be accommodated. To satisfy this requirement, and to interface with the phone system, the rate out of the site controller's concentrator was set at 4800 B/S, a common rate for a telephone line. This capacity allows users a simultaneous burst rate of about 90 wpm. This is quite sufficient in view of the fact that spot checks (6) of channel usage during actual operation indicate a long time average of 2 wpm.

Summarizing the communications requirements for the individual user and his site controller, the maximum terminal input data rate is 1260 B/S or 40,320 B/S to each site controller. The maximum output data rate from each site controller is 4800 B/S, which sets the average output rate from each terminal at 150 B/S or roughly 90 words per minute. These results are given in Table 2.1.

2.4 CPU AND NIU CHARACTERISTICS

These data rates determine the rates at which the NIU's and CPU need to operate. Since there are at most 1,008 users, each receiving 1260 B/S from the NIU, the NIU must send out 1.2×10^6 B/S or 1.2M B/S. Based on site controller output rates of 4800 B/S, the NIU must receive at a rate of 1.512×10^5 B/S or 151.2K B/S. The CPU must be able to send and receive at the rate of the NIU. Therefore input/output rates for the CPU are the same as for the NIU. The communication specifications for the CPU and NIU are given in Table 2.2.

The computation speed of the computer, and the amount of computation required by each request, determine how long it will take for the computer to react to the users' requests. System designers have set the average reaction time at one tenth of a second. In addition,

Table 2.1: Communication Specifications For PLATO IV
User Terminals and Site Controllers (*)

<u>TERMINAL</u>	<u>DATA RATE</u>	
	<u>Bits Per Second</u>	<u>Words Per Minute (WPM)</u>
INPUT RATE (MAXIMUM) From CPU	1260	720
OUTPUT RATE (MAXIMUM) To CPU	4800	3100*
OUTPUT (AVERAGE ⁺)	150	90

<u>SITE CONTROLLER</u>	<u>DATA RATE (MAXIMUM)</u>	
	<u>Bits Per Second</u>	<u>Words Per Minute (WPM)</u>
INPUT From CPU	40,320	23,040
OUTPUT To CPU	4,800	3,100

Table 2.2: Communication Specifications For PLATO IV
NIU and CPU

<u>NIU</u>	IN(Bits/Sec.)	OUT(Bits/Sec.)	<u>CPU</u>	IN(Bits/Sec.)	OUT(Bits/Sec.)
	151.2×10^3	1.2×10^6		151.2×10^3	1.2×10^6

*Maximum rate reached when only one terminal of the 32 active.

⁺Average rate for equal usage by all 32 users.

NOTE: All data communications are at a bit error rate $\leq 10^{-5}$.

designers have observed that the average response uses 1000 computer instructions, and they have experimentally determined that the average student request rate was .25 requests per second. For 1,008 students that means 252 requests per second. Finally they have used these data in an equation from queueing theory (9) to relate average waiting time ($E(w)$) to request rate, (M), standard deviation of request rate, (σ), and average execution time, $E(t)$:

$$E(w) = \frac{m E(t) + m^2 \sigma^2}{2m (1 - m E(t))} \quad (2.1)$$

The results indicated that 1,008 users could be served by any of several existing large scale computers, including the CDC Cyber 73, which was chosen for system implementation.

2.5 PRESENT PLATO COMMUNICATIONS CONFIGURATION

This section describes the communications networks presently serving PLATO. There are about 900 users in the PLATO IV system (6). They are scattered from Maine to California, with a significant fraction located in the Champaign-Urbana area. Terminals are connected to the system by one of two communication channels: 1) leased (or dedicated) phone lines and 2) Microwave radio. Figure 2.2 gives some examples of how users are presently connected. Note that while some terminals are located at the actual computer site, others, located at a distance, share a voice grade line with three fellow users. Still others receive data on a microwave radio channel.

2.5.1 Communications with Local Terminals

Local terminals are connected by wire cables directly to their associated site controller. The site controller is ~~connected~~ directly to the NIU. This is the simplest and least costly method for supplying the required communications for terminals located at the computer site.

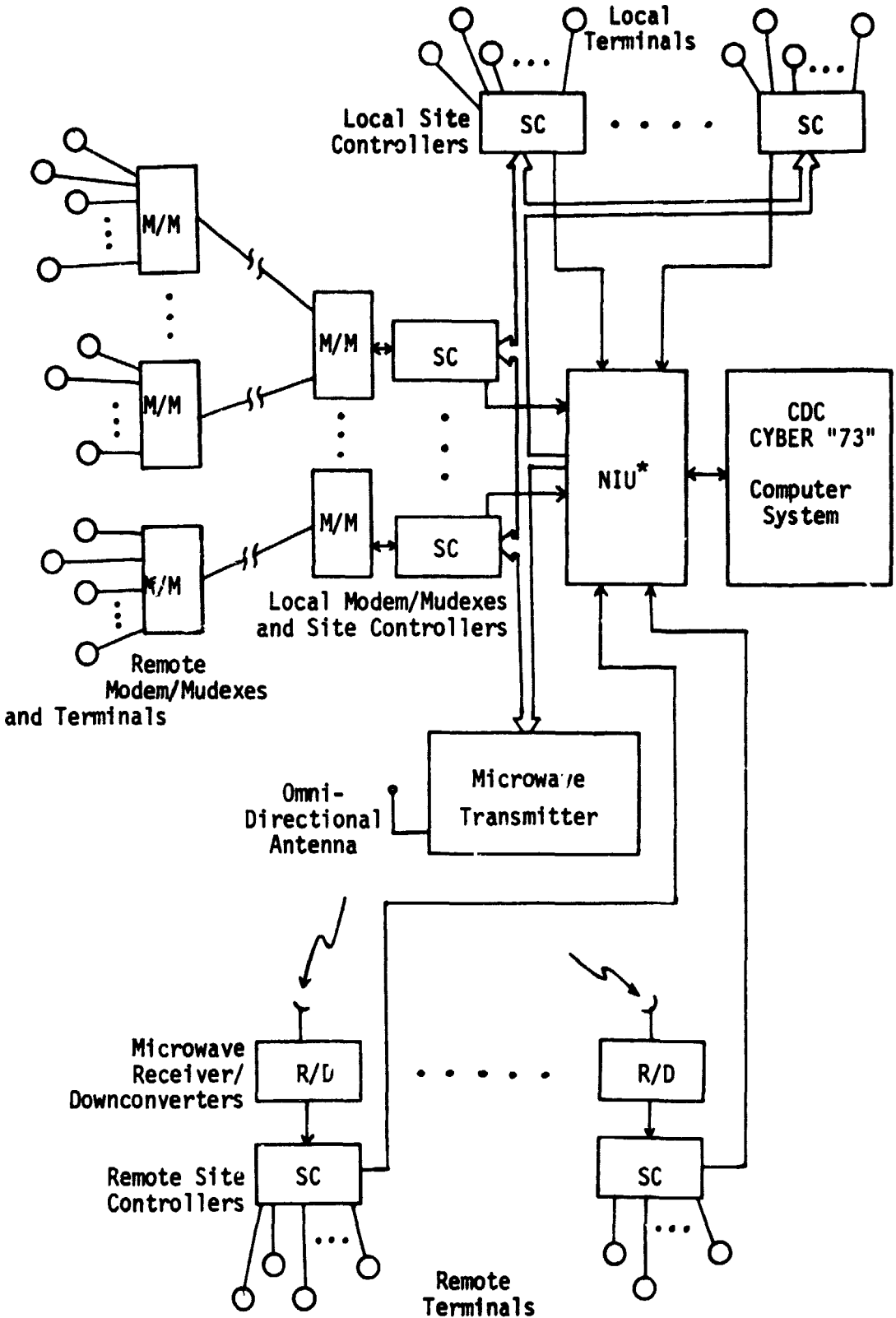

*Note: All lines into NIU are 4800B/S; those to SC's from NIU are 1.2MB/S
Figure 2.2: Examples of Present PLATO IV Network (7)

Communications with remote terminals is carried by either radio or telephone lines with associated digital communications hardware.

2.5.2 Telephone Communications for Remotely Located Terminals

In order to understand the PLATO IV remote terminal communications scheme, consider Figure 2.2. This diagram shows how users in California, for example, are tied into the system. We see that the site controller for "telephone-line" users is located at the central computer site, rather than at the terminal location. It sends data to, and receives data from, a Modem/Mudex (MODulator-DEModulator/MUltiplexor-DEmultipleXor). Each of the modem/mudexes is connected to eight full-duplex (two way) telephone lines, each capable of carrying 4800 B/S in each direction. Each of these eight lines travels from the computer site to the user site, where it is connected to a remote modem/mudex. The remote modem/mudex, in turn, serves four user terminals receiving 1200 B/S apiece.

All mudexes operate in an asynchronous-demand-time-division-multiple-access (ADTDMA) mode. That is, users demand the channel in an unsynchronized (from one user to others) manner, thereby sharing the time available on the mudex. The remote modem/mudex, for example, polls the data lines from the four users assigned to it, and when one of the lines indicates a key has been struck, it informs the three non-keyed users that it is busy sending the depressed key. Any key presses of the other three users during the interval that the depressed key is being sent are stored in a one word buffer for transmission immediately following the present transmission. The longest time any key has to wait before being transmitted is the length of time it takes to send three keys, i.e. one from each of the other three users. Therefore

each user is guaranteed one-fourth of the output data rate of the remote mudex, which means 1200 B/S per user. This rate corresponds to 3100 words per minute, far above any user typing capability.

The local modem/mudex polls the remote ones for data, which it multiplexes onto the 4800 B/S full duplex line to the site controller, again using the ADTDM mode. This time the incoming lines share the outgoing line with seven other incoming lines each carrying data from four users. Therefore, when all 32 users share this line equally, they send data over it at a rate of 150 bits per second, which corresponds to a typing rate of about 90 wpm. Statistically speaking, the channel can support burst rates much greater than 90 wpm. In order to insure that no data is lost at the local mudex, each of the eight lines is buffered by a memory capable of holding four keys. Thus, if the site controller is sending data from other users to the NIU, new data will be stored rather than lost. (6)

Once data is received at the NIU, it is sent to the computer, where the appropriate response is produced and sent back along the path of full duplex lines over which the corresponding request arrived. In order to realize rates of 1200 B/S to each terminal, there are eight half-duplex lines of 4800 B/S sent from the NIU to each site controller.

2.5.3 Microwave Radio Communications for Terminals in the Urbana Area

Microwave radio is the most recent addition to PLATO IV's communication system. Four PLATO IV classrooms of 32 terminals have been added to the system by this method. The classrooms lie within 15 miles of the University of Illinois campus in Champaign-Urbana.

The block diagram of the system is given in Figure 2.2. The

digital television transmitter output of the NIU is sent to a microwave transmitter, where a 2,150 MHz carrier is modulated and transmitted with a power of 10 watts through an omnidirectional antenna. Each classroom has a microwave receiver and a downconverter (R/D). These devices convert the received signal into a format compatible with the site controllers. The site controllers send 1200 bits/sec to each user's terminal. Requests from the 32 users are polled, concentrated at the site controller, and sent via one half-duplex phone line to the NIU. (6) By using a radio transmitter in the forward direction, the cost of transmitter and receiver/downconverters is substituted for the cost of numerous telephone lines. Furthermore, the incremental cost of adding the $N + 1$ st group of 32 terminals at a new site within the coverage area is only the cost of one more receiver/downconverter plus $\frac{N + 1}{N + 1}$ times the cost of the transmitter. This is true only so long as $N + 1$ does not exceed 32, since the microwave channel serves a maximum of 1,008 users.

2.5.4 Cost Comparison: Microwave vs. Telephone for the Urbana Area

Microwave costs compare favorably to the costs of modem/mudexes and telephone lines, as the following quantitative discussion of costs shows.

Users located at the computer site pay the lowest communications costs. They have only to pay for their share of the site controller and NIU costs and a minimal installation charge for lines to and from the site controller. The NIU costs \$30,000 and site controllers cost \$9,000 apiece.

Remote users who are connected via telephone lines pay for their share of the NIU and site controller plus additional costs for leasing

the lines and buying the modem/mudexes needed. Modem/mudexes made by Penril cost \$5,000 for the pair of one local and one remote type. (6) Telephone line rates are based on numerous factors including distance and density of lines over that route. The latter factor is what Bell Telephone calls its "high or low D" (density) tariff. As of August 1974 a full-duplex line from Champaign-Urbana to Los Angeles, California cost \$1,000 per month. Full-duplex lines cost only 10% more than half-duplex lines.

Communication costs for the microwave radio system include the cost of the transmitter, the antenna and tower, and the cost of the receiver/downconverter and the antenna. The 10-watt transmitter is being leased for about \$1500 per month with standby spare from Micro Band Inc. Receiver/downconverters are leased for \$40/month from the same vendor. Table 2.3 summarizes costs for various sections of the above communication links. Users linked via the microwave system pay about \$5 per terminal per month. If they are connected via telephone lines instead, costs would be about \$45 per terminal per month. The remainder of this thesis describes costs of various communications networks in detail.

2.6 OPERATIONAL CAPACITY OF PLATO IV

The 1008 terminal capacity of the PLATO IV system under development at the University of Illinois represents a lower bound rather than an upper bound. (6) This conservative estimate of system capacity is due to two constraints imposed by the experimental nature of the present system. First, it is generally true in the experimental system that groups of 32 users are not simultaneously working on a given lesson. If most users shared lessons, PLATO would have to store only one lesson

Table 2.3: Summary of PLATO IV Communications Costs (6)

ITEM	TERMS	NUMBER NEEDED PER TERMINAL	COST
1. Voice Grade Telephone line (4800 Band) Full-Duplex	Rented	.25	*
2. Modem/Mudex	Bought	1	\$5,000
3. Site Controller	Bought	$\frac{1}{32}$	\$9,000
4. Network Interface Unit (NIU)	Bought	$\frac{1}{1008}$	\$30,000
5. Microwave Transmitter (includes spare)	Leased	**	\$1,500/month
6. Transmitter tower and Antenna	Leased	**	Incl. with Transmitter
7. Receiver/Downconverter	Leased	+	\$40/month
8. PLATO IV Terminal (less audio)	Bought	1.0	\$5,300
9. PLATO IV Terminal with audio	Bought	++	\$7,800

Notes:

*Costs are computed as functions of distance and density of data transmission between user and computer

**Microwave System can serve all users located within 15 miles of tower.

+Receiver/Downconverter can serve from 1 to 1008 users.

++Audio is optional.

in fast access core memory per 32 users. Second, many of the terminals are being used for authoring and other operations that consume large amounts of CPU time and core memory causing a deterioration in the system's response time to students' inputs and in its capacity. Therefore, the system is limited by its core memory size and by its computational speed.

In an operational system users might be grouped in groups of nearly 32 users and might share lessons more frequently, relaxing the limitation imposed by the amount of core memory available. Authoring, progress checks and other administrative functions could be done in the evenings when the system would otherwise be unused. Moreover, if the use of PLATO becomes widespread, course production could be centralized, which would reduce this load on most of the systems. Thus the CPU in an operational system may execute only lesson material and not have to create new material or modify old lessons and therefore the limitation imposed by the computational speed and capacity of the CPU could be relaxed.

Based on these likely differences between the operational system and the experimental system, we assume a system capacity of 4032 terminals in developing our communications network designs for operational PLATO IV systems.

3. DISTRIBUTION OF PLATO IV OVER LEASED TELEPHONE LINES

3.1 METHOD OF ANALYSIS

This chapter designs optimal, telephone-based communications systems for PLATO distribution and calculates their costs. Section 3.2 describes available phone company services and state-of-the-art interconnection devices for incorporation in system designs. This Section also defines hardware functions and limitations, and it discusses telephone services and rates. Section 3.3 gives possible network configurations using the services and devices described in Section 3.2. In Section 3.3, we tabulate costs and give a decision criterion for finding the most economical configuration. The best configuration decision is a function of the number of users at a remote site and the distance between the remote site and the central computer. Section 3.4 presents example configurations and illustrates how the previous Section can be used by designing example networks. Thus, given the basic characteristics of a remote CAI site, one can find the least costly communications network employing leased telephone lines using the information presented in this chapter.

3.2 DESCRIPTION OF TELEPHONE SERVICES AND HARDWARE DEVICES

Our discussion of telephone services will be restricted to those offered over voice grade lines. The Bell system offers a special fifty-six kilobit per second (KB/S) data service in addition to the more popular 1200, 2400, 4800, 7200 and 9600 bit/sec (B/S) rates available over voice grade lines. However, for our application, the cost of the 56KB/S service is prohibitive; costs for line installation or acquisition and increased costs of modems and multiplexors, capable of operating at 56KB/S, are much higher than those for voice grade lines (10).

In deciding the least expensive way to connect a group of terminals to the system, we consider the relative costs of necessary hardware devices (modems and multiplexor-demultiplexors) as well as the cost of the telephone lines. Deciding which of two bit rates to use, for example, is based on cost trade-offs between more sophisticated (and more costly) hardware on one hand and the cost of additional lines on the other.

We will see four ways that users can be connected over telephone lines. Decisions as to which network is the most economical for a given site depend on the number of users at a site and the distance from the site to the central computer.

Table 3.1 (10) presents the monthly charges for AT&T telephone lines. The Table is divided into two parts; 3.1.a) gives charges for the lines and 3.1.b) gives charges for auxiliary services in terms of installation and monthly costs. Table 3.1.a) gives costs of the basic "3002" voice grade (300-3 KHz) line. Customers are charged either by the quarter mile or the mile depending on where the computer and user sites are located, Zones and exchanges are defined by AT&T. To find out exactly which rates apply in a specific instance, one must contact his local AT&T business office.

Table 3.1.b) shows prices for interface circuits needed to "protect" the phone line from non-Bell hardware devices. There is an installation charge as well as a monthly charge for these devices. Some hardware devices, especially those operating at high data rates, need to operate over a specially conditioned line. Therefore, Table 3.1.b) gives the charges for conditioning a line. Costs are for installation and monthly rental.

Table 3.1.a) AT&T Monthly Charges for Intra-State Leased Lines* (10)

Location of User and Computer	Line Measured in Increments of	Installation Charge	Minimum Charge	Charge per Increment
Same Exchange	1/4 air miles	\$26	\$8.80	\$2.20
" zone	"	"	"	"
Contiguous Zone	"	"	"	"
Non-Contiguous Zone	"	"	"	"
Between exchanges (1-250 air miles)	1 air mile	"	\$3.25	\$3.25
Between exchanges (250-500 air miles)	1 air mile	"	none	\$2.94
Between exchanges (500 and up)	1 air mile	"	none	\$2.63

Table 3.1.b) Additional AT&T Charges

<u>Service</u>	<u>Cost per line per month</u>	<u>Installation cost</u>
Interface for non-AT&T hardware	\$3 to \$10 [†]	\$24
C2 Conditioning	\$27.00	\$300

*Costs are given for full duplex lines as of August, 1974. Half duplex lines cost 10% less.

[†]This cost depends on type of interface required. There are nearly 80 different types in service.

From Table 3.1 the line cost per month and per S.C.H. can be computed as follows:

$$\text{Cost of line/month} = \frac{\text{I.C.}}{m} + \text{P.C.}$$

$$\text{Cost/S.C.H.} = \text{Monthly cost/S.C.H.'s/month} \quad (3.2)$$

Where m is the number of months to amortization, I.C. is the installation charge and P.C. is the monthly phone company charge. It should be noted that the number of months to amortization in Equation (3.1) refers to hardware devices to be used in conjunction with the phone lines and not the phone lines themselves. Hardware devices are commonly amortized over a five year period.

In deciding what type of hardware to use for a communication link between the central computer and a cluster of remote terminals, one must consider the several possible configurations capable of delivering the desired service. Either of two types of devices, the local distribution service unit (LDSU) and the modem, can be used to send digital data over phone lines.

An LDSU can send data at rates up to 9600 B/S over an unconditioned voice grade phone line to sites located up to 15 miles away. It is distance-limited due to the electrical characteristics of its output data signal (11).

In order to enjoy the full 9600 B/S transmission capability of the LDSU when each user needs to receive only 1200 B/S (as in the PLATO IV system), it is necessary to combine (multiplex) data from several users onto the same phone line. Multiplexing causes the data rate over the channel to be the sum of the rates of the individual users. When multiplexed data arrives at the user site, it must be separated (demultiplexed) so that each user receives only the data intended for

him. In addition, users' data headed back to the computer must be multiplexed. Therefore, at both the computer site and the user site, data must be multiplexed and demultiplexed. Devices that perform these two functions are generally called "mux's" in the parlance of data communications. In order to emphasize the fact that both Multiplexing and Demultiplexing are performed by such devices, they will be called "mudexes" throughout this thesis.

As many as eight users receiving and sending data at 1200 B/S can share a single phone line through a mudex and an LDSU operating at 9600 B/S. Of course, there must also be a mudex and a LDSU at the central computer's end of the phone line. Thus, users pay less for phone lines but incur the added cost of their share of the two mudexes.

Modems (MODulator/DEModulators), the second type of device which can be used to send digital data over phone lines, send data using different electrical techniques than do LDSU's. As a result, modems possess the advantage of being able to send data anywhere, regardless of distance. The modem's ability to send data over large distances is achieved only at a cost greater than that of LDSU's. Modems are available for sending data from 1200 B/S to 9600 B/S over telephone lines. Depending on the modulation format employed in the modem, it may or may not need a "C2 conditioned" phone line for transmission at a given rate. As a general rule, 9600 B/S modems need conditioning. However, to be sure, one must consult a service representative of the company which manufactures the device. Modems are like LDSU's in that they can be used in conjunction with mudexes to allow several

users access to a single phone line. As with LDSU's, when using mudexes both a modem and a mudex must be located at each end of the phone line.

In order to supply price information for LDSU's, modems, and mudexes used in this study, we chose the line of equipment offered by the Codex Corporation. Based on market surveys of data communications hardware (12), we believe the prices of this viable firm to be competitive and thus representative.

Codex offers a "Model 8200" LDSU capable of sending at rates of 1200-9600 B/S through unconditioned phone lines over distances up to fifteen miles. Their 4800 B/S modem has an optional mudex capable of multiplexing up to four 1200 B/S lines. The 9600 B/S modem from Codex does not have its own optional mudex. However, a model 910 mudex can be used in conjunction with either the 9600 modem or the 8200 LDSU to allow up to eight 1200 B/S channels over one phone line. The Codex 9600 modem requires C2 conditioned phone lines. Table 3.2 (13) gives a summary of specifications and costs for the Codex equipment mentioned above. Figure 3.1 shows how users can be connected to the PLATO IV system using Codex data communications devices (14).

Based on the information in Table 3.1 and 3.2, the costs of the example configurations in Figure 3.1 can be computed. From the four examples in Figure 3.1, we can synthesize any possible link needed for connecting a group of users to the PLATO IV system. We present these cost calculations in the next section, and the last section of this chapter synthesizes some example links.

Table 3.2 Data Communications Devices offered by the Codex Corporation (13)

<u>Modems</u>					
Speed (B/S)	Model #	With Mudex?	Conditioned Line Needed?	# of Channels on Mudex	Price
4800	4800C	Yes	No	4	\$5,475
9600	9600C	No	Yes	-	\$9,700
Mudex: Model 910 8 channels					\$2,160 + c · \$252*
Local Distribution Service Unit (LDSU):					
Model 8200, 1200-9600 B/S, unconditioned line [†]					\$995

*c = Number of channels.

[†]8200 LDSU's can send data up to fifteen miles.

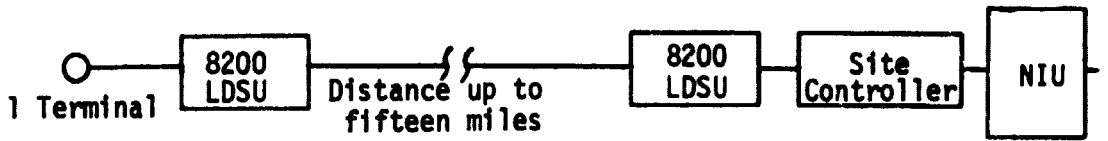

a) LDSU's only

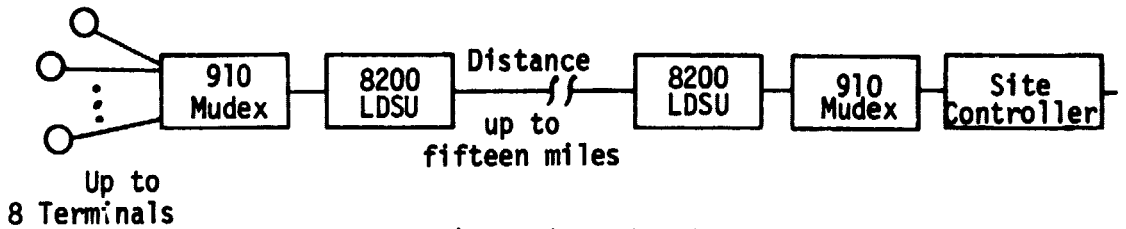

b) LDSU's and muxes

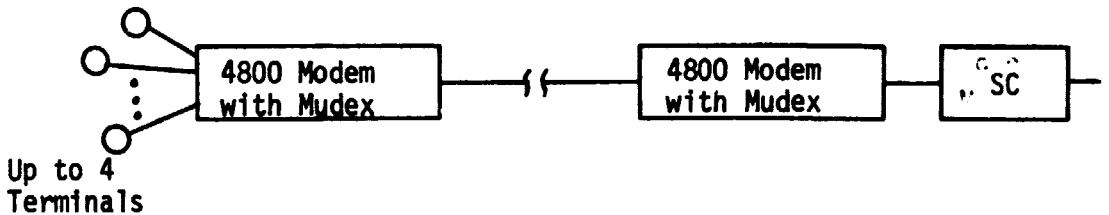

c) 4800B/S Modem and its muxer

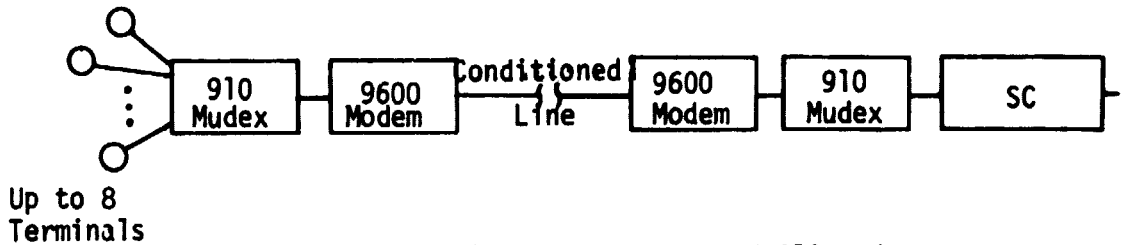

d) 9600B/S Modem and 910 muxer

Figure 3.1: Communication Configurations Using Codex Equipment (14)

3.3 COSTS FOR EXAMPLE CONFIGURATIONS

3.3.1 Configurations Using LDSU's

3.3.1.1 One Terminal Link

Terminals connected through LDSU's must be within fifteen miles of the computer. They can use regular unconditioned voice lines (11). Monthly costs are calculated by adding the cost of the hardware and other one-time charges, such as installation, amortized over a five year period, to the monthly charges for the telephone lines. Table 3.3 (13) is a tabulation of costs for a one-terminal link as shown in Figure 3.1a).

3.3.1.2 Many Terminal, LDSU Link

The LDSU can be used in conjunction with a model 910 mudex to serve as many as eight users as shown in Figure 3.16. Table 3.4 (13) itemizes the costs for connecting users via LDSU's and 910 mudexes -- with and without a 35% discount for large quantity purchases. The question of whether to use n "LDSU only" links or one LDSU link with 910 mudexes can be answered using data from Tables 3.3 and 3.4 (13). For an urban CAI system of 4032 users, enough equipment would be purchased to deserve the 35% discount. The decision as to which of the first two links shown in Figure 3.1 to use for users within fifteen miles of the computer can be stated mathematically as:

$$\begin{array}{ccc}
 \frac{28.39 + r \cdot d}{160} & \begin{array}{c} \text{LDSU only} \\ > \\ < \\ \text{LDSU and} \\ \text{Mudex} \end{array} & \frac{75.19 + 5.46n + r \cdot d}{n \cdot 160} \\
 & & (3.3)
 \end{array}$$

where $\begin{matrix} a \\ \wedge \\ b \end{matrix}$ means if the left side is larger choose a, otherwise choose b; r is the phone line rate in dollars per mile, d is the line distance in

Table 3.3 Costs for One Terminal LDSU Link (13)

a) Without 35% discount on Codex devices.

Item	Quantity Per Link	Price each (Acquisition and Installation)	Cost/month
Codex 8200 LDSU	2	\$995	\$33.17
Unconditioned Telephone Line	1	\$ 50	\$(6.83 + r·d)*

$$\text{Cost/terminal - month} = \$(40.00 + r \cdot d)$$

$$^+\text{Cost/S.C.H.} = \left(25 + \frac{r \cdot d}{1.5}\right) \text{¢}$$

b) With 35% discount on Codex devices.

Item	Quantity	Price each (Acquisition and Installation)	Cost/month
Codex 8200 LDSU	2	\$646.75	\$21.56
Unconditioned Telephone Line	1	\$ 50	\$(6.83 + r·d)

$$\text{Cost/terminal - month} = \$(28.39 + r \cdot d)$$

$$^+\text{Cost/S.C.H.} = \left(18 + \frac{r \cdot d}{1.60}\right) \text{¢}$$

*See Table 3.1 for values of r. r = (\$/mile-month); d = distance (air miles)

+Assuming 160 S.C.H./month.

Table 3.4 Costs for LDSU and Mux Link (13)

a) Without 35% discount on Codex devices.

Item	Quantity Per Link	Price each (Acquisition and Installation)	Cost/month
Codex 8200 LDSU	2	\$995	\$33.17
Unconditioned Telephone Line	1	\$ 50	\$(6.83 + r·d)*
Codex 910 Muxex	2	\$2,160 + \$252·(n)**	\$(72.00 + 8.40n)

$$\text{Cost/terminal - month} = \frac{\$(112 + 8.4n + r \cdot d)}{n}$$

$$\text{Cost/S.C.H}^{\dagger} = \frac{(112 + 8.4 \cdot n + r \cdot d)}{160 \cdot n}$$

b) With 35% discount on Codex devices.

Item	Quantity Per Link	Price each (Acquisition and Installation)	Cost/month
8200 LDSU	2	\$646.75	\$21.56
Phone Line	1	\$ 50.	\$(6.83 + r·d)*
910 Muxex	2	\$1404 + \$163.8 (n)	\$(46.80 + 5.46 n)

$$\text{Cost/terminal - month} = \frac{\$(75.19 + 5.46 n + r \cdot d)}{n}$$

$$+\text{Cost/S.C.H.} = \frac{(75.19 + 5.46 n + r \cdot d)}{160 \cdot n}$$

*See Table 3.1 for values of r: r = (\$/mile month); d = distance (air miles)

**n = number of terminals sharing a line (1 < n < 8)

†Assuming 160 S.C.H./month.

miles and n is the number of terminals sharing the phone line. The two sides of the decision equation are plotted as functions of distance (d) and number of users per line (n) in Figure 3.2. The rate per mile for the phone line is set at \$3.00 so that the dependence of costs on distance can be readily seen. Figure 3.2 indicates that the only case when a site with two terminals should be connected using four LDSU's and two phone lines is when the site is within ten miles of the computer. Due to difficulty in defining a telephone exchange geographically we were unable to determine where intra-exchange rates should be substituted for inter-exchange rates in equation 3.3. Thus Figure 3.2 does not have values for distances less than two miles.

3.3.2 Configurations Using Modems

When terminals are located more than fifteen miles from the computer, modems must be substituted for LDSU's. Two of the more popular modems presently available transmit data at 4800 or 9600 bits per second. The 4800 B/S model can serve from one to four users with their optional mudex. Costs for systems configured as shown in Figure 3.1c are given in Table 3.5. The cost/S.C.H. is tabulated twice - with and without the 35% discount for large quantity purchases (14).

Table 3.6 gives the costs for links configured as shown in Figure 3.1d. The 9600 B/S modem from Codex must be used with a model 910 mudex that can accept up to eight channels of 1200 B/S data in both directions. As with the 4800 B/S modem, there is no restriction on distance.

A comparison can be made based on the costs computed in Tables 3.5 and 3.6 from which one can decide whether a 4800 B/S or 9600 B/S

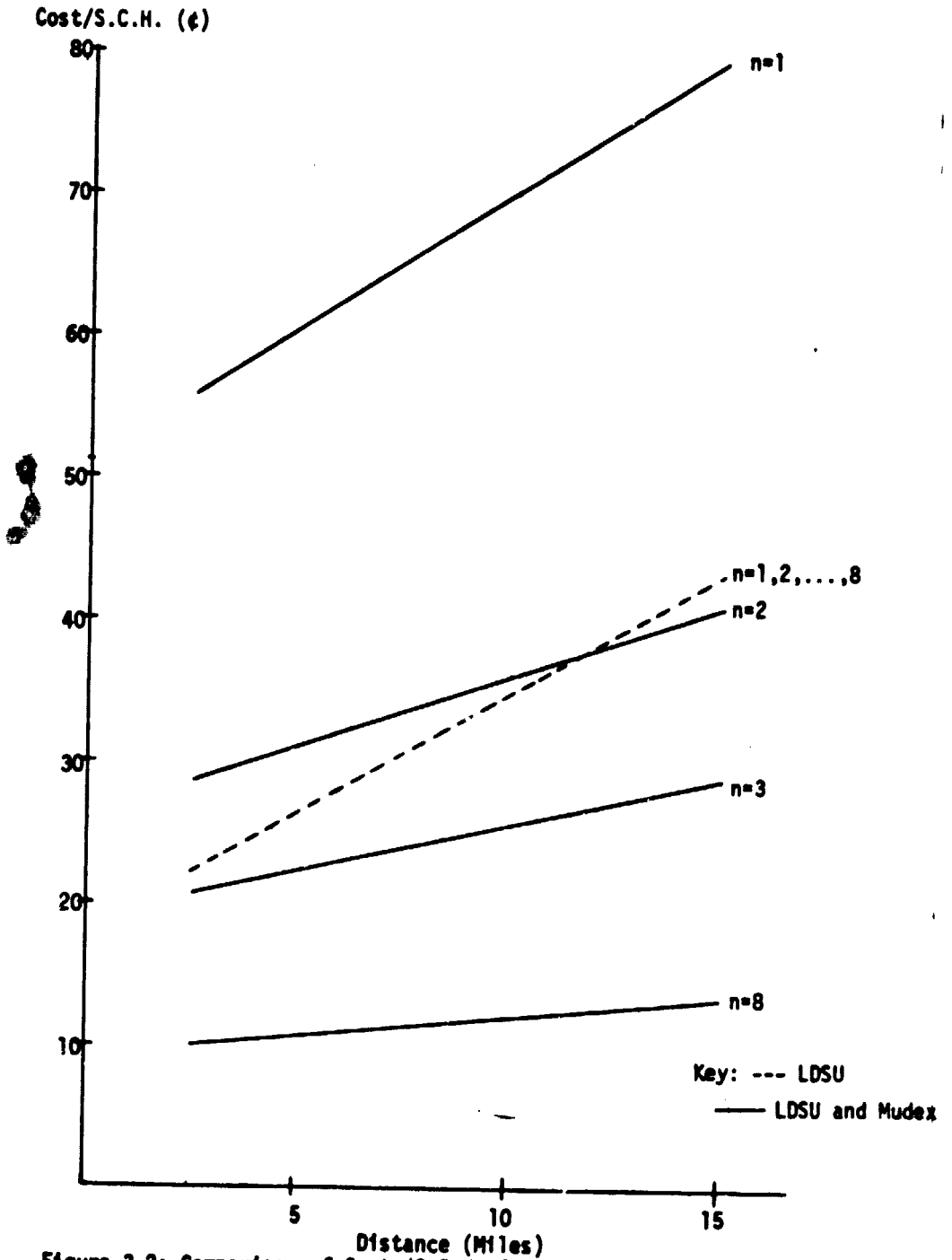

Figure 3.2: Comparison of Costs/S.C.H. for n Terminals Per Site; LDSU's Versus LDSU's and Mudex

Table 3.5 Costs for Link Employing 4800 B/S Modems and Muxes

3.5a Without 35% discount

Item	Quantity/ Link	Price (Acq./Inst.) (each)	Cost/month
Codex 4800 modem	2	\$4800	\$160.00
4 channel mux	2	\$ 675	\$ 22.50
phone line (unconditioned)	1	\$ 50	\$(6.83 + r·d)*

$$**\text{Cost}/\text{terminal-month} = \frac{\$(189.33 + r \cdot d)}{n}$$

$$+\text{Cost}/\text{S.C.H.} = \frac{\$(189.33 + r \cdot d)}{160 \cdot n}$$

3.5b With 35% discount

Item	Quantity	Price (Acq./Inst.) (each)	Cost/month
4800 Modem	2	\$3120	\$104.00
4 channel mux	2	\$ 438.75	\$ 14.63
phone line (unconditioned)	1	\$ 50	\$(6.83 + r·d)*

$$\text{Cost}/\text{terminal-month} = \frac{\$(125.46 + r \cdot d)}{n}$$

$$+\text{Cost}/\text{S.C.H.} = \frac{\$(125.46 + r \cdot d)}{160 \cdot n}$$

*See Table 3.1 for values of r. r=rate (\$/mile-month); d=distance (air miles).

**n = number of terminals sharing a line (1 ≤ n ≤ 4).

+Assuming 160 S.C.H./month.

Table 3.6 Costs for Link Employing 9600 B/S Modems and Eight-Channel Muxes

a) Without 35% discount.

Item	Quantity/ Link	Price (Acq./Inst.) (each)	Cost/month
Codex 9600 modem	2	\$9,750	\$325.00
Codex 910 muxes	2	\$2,160 + \$252n	\$(72.00 + \$8.40 n)
Conditioned Phone line	1	\$350	\$(38.83 + r·d*)

$$**\text{Cost/user-month} = \frac{\$(435.83 + 8.40n + r \cdot d)}{n}$$

$$+\text{Cost/S.C.H.} = \frac{\$(435.83 + 8.40n + r \cdot d)}{160 n}$$

b) With 35% discount.

Item	Quantity/ Link	Price (Acq./Inst.) (each)	Cost/month
9600 modem	2	\$6,337.50	\$211.25
910 muxes	2	\$1404 + \$163.8n	\$(46.80 + 5.46n)
phone line (conditioned)	1	\$350	\$(38.83 + r·d*)

$$\text{Cost/terminal-month} = \frac{\$(296.88 + 5.46n + r \cdot d)}{n}$$

$$+\text{Cost/S.C.H.} = \frac{\$(296.88 + 5.46n + r \cdot d)}{160n}$$

*See Table 3.1 for values of r. r=rate (\$/mile-month); d=distance (air miles).

**n = number of terminals sharing a line.

+Assuming 160 S.C.H./month.

modem can more economically satisfy his communication needs. The decision is based on the number of terminals at the site sharing each line (n) and the product of rate r (\$/mile) and distance d (miles). Assuming a 35% discount this decision equation can be written as:

$$\frac{(125.46 + rd)}{n_{4800}} \geq \frac{9600}{4800} \frac{(296.88 + 5.46 n_{9600} + rd)}{n_{9600}} \quad (3.4)$$

where n_i represents the number of users sharing an i bit per second link, ($1 \leq n_{4800} \leq 4$) and ($1 \leq n_{9600} \leq 8$). The quantities on either side of the decision equation are the monthly costs for the two types of modems.

Substituting $n_{4800} = 4$ and $n_{9600} = 8$ into (3.4) yields:

$$31.36 + \frac{rd}{4} \geq \frac{9600}{4800} \left(42.57 + \frac{rd}{8} \right)$$

which can be written more succinctly as:

$$rd \geq \frac{9600}{4800} 89.68 \quad (3.5)$$

For $r = \$3.00/\text{mile-month}$ the point at which it becomes cheaper to use one 9600 B/S link (with its more costly phone line charges and mudex) than to employ two 4800 B/S links, is at about 30 miles. This crossover point is a function of n_{4800} and n_{9600} as can be seen in (3.4). To compare 4800 and 9600 B/S service completely, one needs to get cost per terminal-month as a function of the number of users at his site. This is done by using Tables 3.5 and 3.6 and comparing costs for the 4800 and 9600 B/S links for a range of from five to eight users at a given remote site. For each case a crossover point

can be established. The results of this analysis indicate that the crossover points for five, six, seven and eight users are all between 24 miles and 30 miles for $r = \$3/\text{mile-month}$. When connecting four or fewer users, the 4800 B/S service is cheaper than the 9600 B/S regardless of distance from the central computer.

3.4 SUMMARY OF PHONE SYSTEM DESIGN METHODOLOGY

Using the above analysis and the previous discussion of LDSU service the cheapest type of service can be determined for any group of users. This guideline is given as Figure 3.3. For more than eight users at one site, one pieces together a system with a mix of 4800 and 9600 B/S links. To cost the system one need only refer to Tables 3.3 through 3.6, and put system parameters into the cost equations computed there. A plot of the cost for the optimum configuration as a function of distance is given in Figure 3.4 for $r = \$3/\text{mile-month}$ and $n = 8$ terminals per phone line.

3.5 NETWORK DESIGN EXAMPLES

In order to illustrate how one would go about designing the most economical system configuration using the results of the cost analysis in the last section, we present the following examples.

3.5.1 LDSU Link Example

Suppose we have a cluster of twenty-five terminals located ten miles from the computer site. Knowing the number of terminals at the site and the distance from the computer to the site, the network designer can use Figure 3.3 to guide him in grouping user terminals so as to minimize communication costs. We first notice from Figure 3.3 that since links are only ten miles long LDSU's should be utilized - either with or without mudexes. We then notice that Figure 3.2

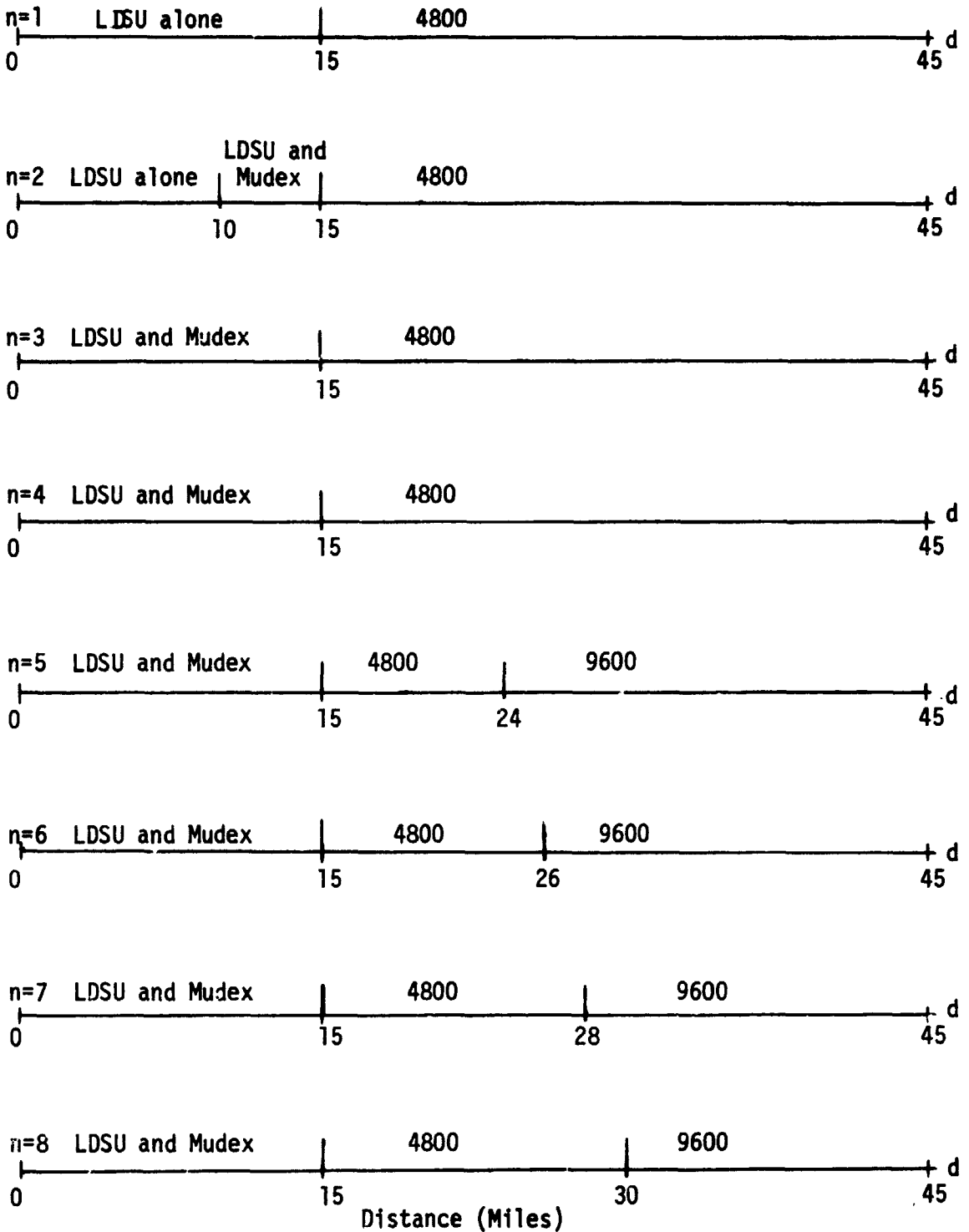

Figure 3.3: Decision Regions as Functions of Number of Users Per Line (n) and Distance Between Remote Site and Computer (d)

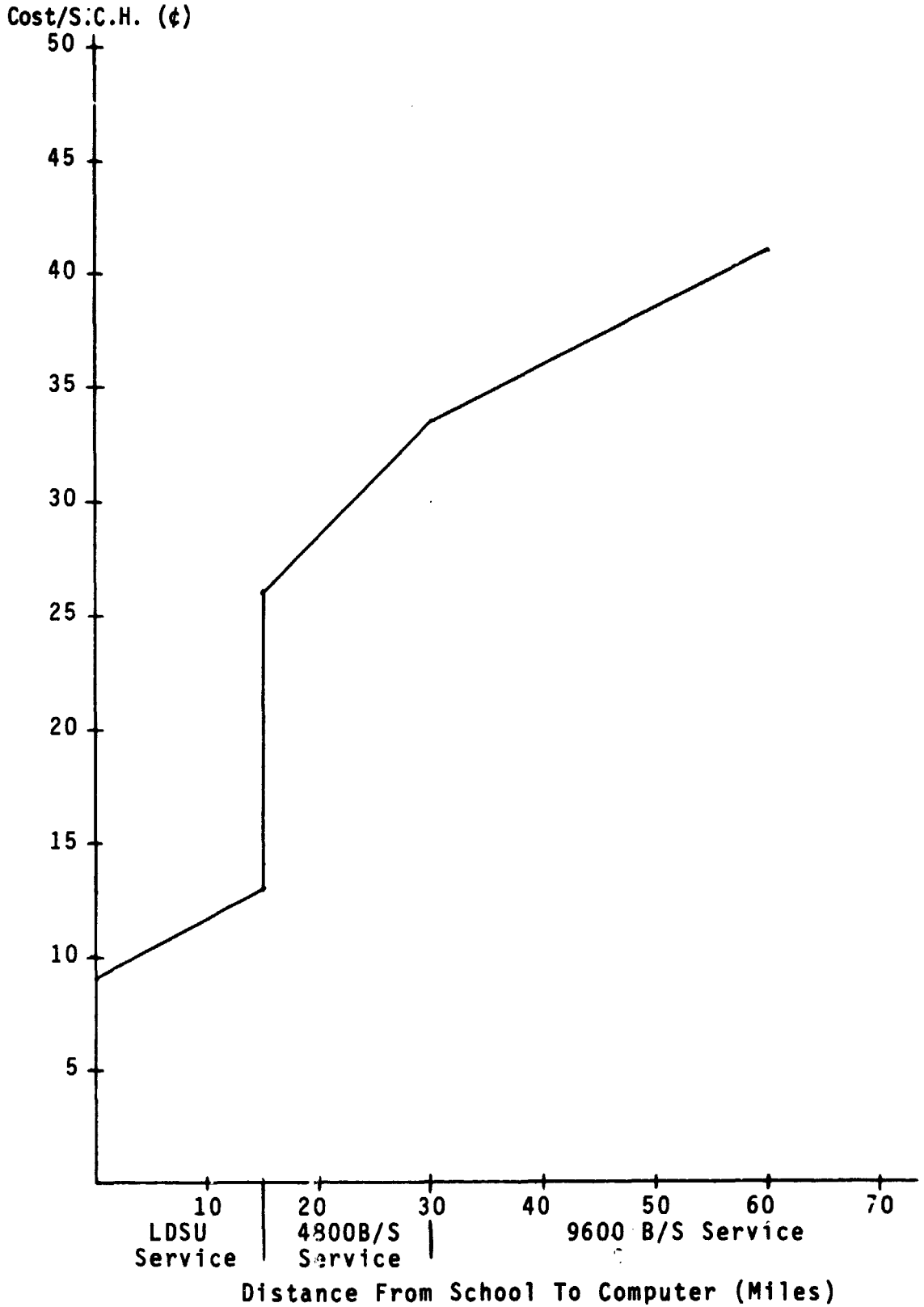

Figure 3.4: Costs of Optimal Configurations for n=8

indicates that when using LDSU's on ten mile links grouping terminals in larger groups costs less. Therefore we arrive at the best grouping by dividing the twenty-five terminals into three groups of eight and one single terminal group. The eight-terminal groups are connected via LDSU's and mudexes (Figure 3.1b) and the single terminal is connected by an LDSU link (Figure 3.1a). From Table 3.4, we find costs for the LDSU and mudex links. Assuming a large-quantity purchase of hardware from Codex we find the appropriate costs in Table 3.4b. The costs are tabulated as follows:

2	8200 LDSUs	\$1,293.50
2	910 Mudexs (8 channels each)	\$2,808.00 + \$327.60 x 8
1	unconditioned phone line	\$50.00 + \$(6.83 + (3x10))/month

Amortizing equipment over the usual five-year period the cost per month for the LDSU and mudex links is \$149.70. For eight terminals per link and 160 student contact hours per month the cost per S.C.H. = 12¢. This cost can be arrived at by substituting $r \cdot d = 30$ and $n = 8$ into the result of Table 3.4b.

The link serving the twenty-fifth terminal has the following costs:

2	8200 LDSUs	\$1,293.50
1	unconditioned phone line	\$50.00 + (\$6.83 + \$3 x 10)/month

or a monthly cost of \$59.22 which means 37¢/S.C.H. This figure can be arrived at by simply substituting $r \cdot d = 30$ into the result of Table 3.3b.

The weighted average cost of the twenty-four users at 12¢/S.C.H. and one at 37¢/S.C.H. at this site is equal to 13¢. Had there been twenty-six users at a site twelve miles from the computer, Figure 3.3 tells us to use four LDSU and mudex links, even though the fourth link would serve only two user terminals.

3.5.2 Modem Link Example

To see how the results of Section 3.3 can be applied to a system using modems, consider a site with thirteen terminals located twenty-five miles from the computer. Figure 3.3 indicates that we should use all 4800 B/S links with mudexes to serve the terminals. Thus we will have three four-terminal 4800 B/S links and one single-terminal 4800 B/S link. Assuming a large-quantity purchase, the cost of the 4800 B/S links is obtained by substituting $r \cdot d = 75$ and $n = 4$ into the result of Table 3.5b. The twelve terminals pay 31¢/S.C.H. Using $r \cdot d = 75$ and $n = 1$ in the price given in Table 3.5b yields a cost of \$1.32/S.C.H. for the single terminal link. Averaging the costs of all links employed for this example gives 39¢/S.C.H.

4. PLATO IV CAI DELIVERED BY SATELLITE

4.1 INTRODUCTION

This chapter will discuss how satellite technology can be applied to deliver the necessary PLATO IV communications capabilities. Two example satellite-based delivery systems will be presented. They are both designed to distribute PLATO IV systems to rural primary and secondary schools in the seventeen mainland states west of Missouri. We chose to apply satellite technology to these states due to the sparse user populations found in them. The first system uses a satellite channel in the forward direction and phone lines for the return channel. Thus the ground stations located at each rural school need only receive data and are less costly than "two-way" or "interactive" stations. The second example system employs satellite channels for both forward and return transmissions.

A disadvantage in using a satellite channel as opposed to a terrestrial link is that data sent over a geostationary satellite link is subjected to a 250 millisecond delay; that is, it takes the information-bearing radio wave 250 milliseconds to traverse the distance of 45,000 miles to the satellite and back. In those applications where interaction must be rapid this delay could become unpleasant if the current student terminal design is used. The present terminal waits until the computer has checked a key press before displaying the character. Perhaps, in a satellite-based system, a microprocessor in each terminal could display characters as they are typed and send blocks of characters later.

4.2 SATELLITE SYSTEM DESIGN AND COSTING METHODOLOGY

We design and cost the two satellite systems using the modified "STAMP" computer program. This program was developed at General Dynamics Corp. in 1971 (15) and has recently been modified at Washington University (16). The program is a tool for synthesizing and optimizing complete satellite systems. It produces design specifications and costs for all system components, including satellite and ground components, when it is given as input such parameters as number of satellite antenna beams, number of carriers and channels per beam, channel bandwidth, and number of ground stations.

4.2.1 Description of the Modified STAMP Program*

"The General Dynamics Satellite System Synthesis Program, (15) called STAMP (Satellite Telecommunication Analysis and Modeling Program), was written as a tool for analyzing satellite communication system requirements. The program synthesizes a least-cost satellite communication system within the constraints of satellite size, power levels, antenna diameters and receiver noise figures while satisfying the user requirements of area of coverage and type and grade of service.

The program incorporates the total system in its optimization. This includes up to three separate types of ground facilities, one or more identical satellites, launch vehicles and uplink and downlink propagation models.

Communication can be handled in any one or combination of four data types: audio, video, facsimile and digital. Each beam is considered separately by the program. This eliminates the need to choose a worst case beam and assume all other beams are identical. Each individual beam can handle any combination of the four data types. A block diagram of the program is shown in Figure 4.1.

The input to the program is read in through the namelist feature. There are seven namelist lists each containing parameters that are related to a specific area of the program.

The program begins by reading in the input data. It then computes the channel characteristics including carrier to

*This description was taken verbatim from Reference (16).

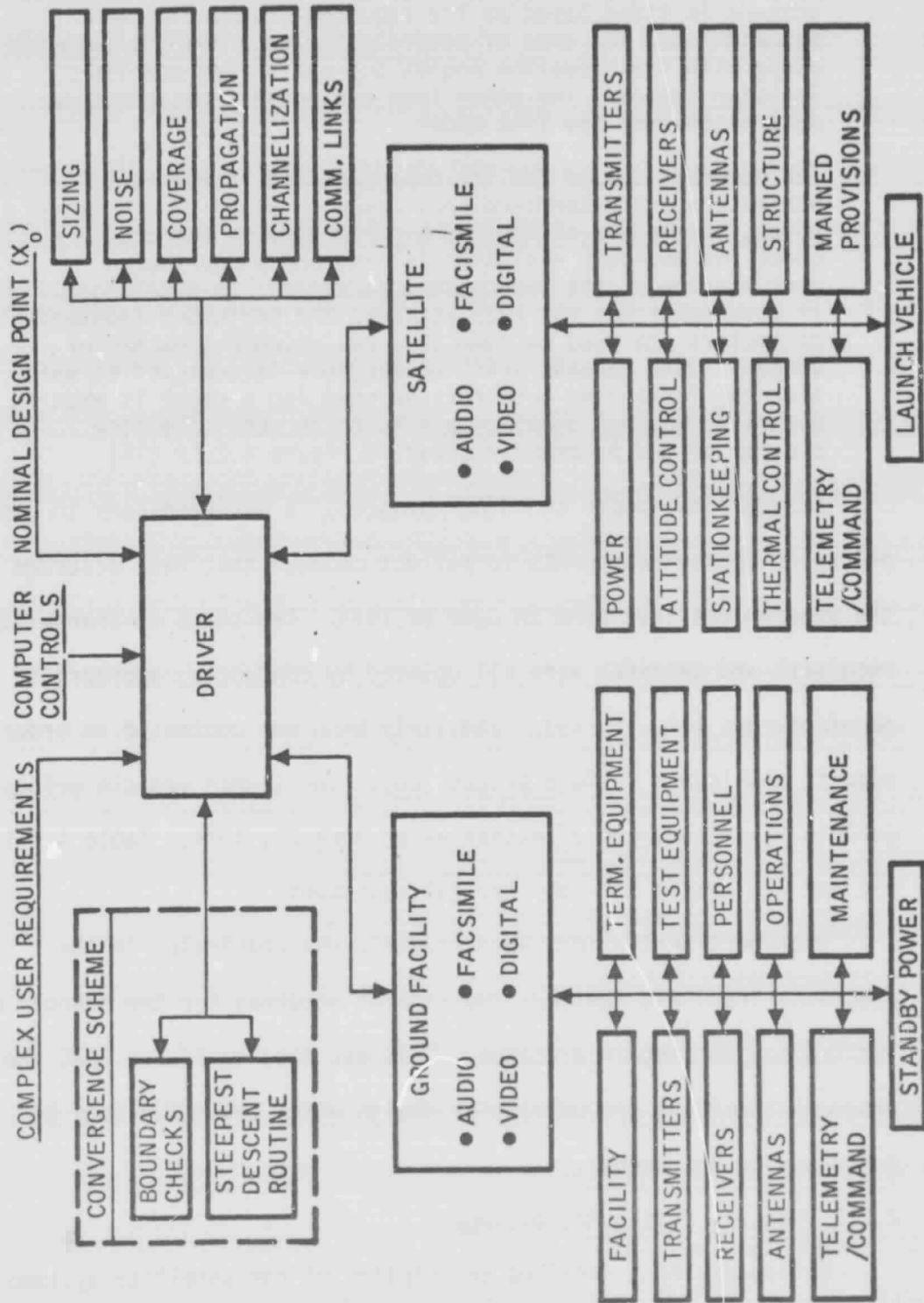

Figure 4.4: STAMP Block Diagram (15)

noise ratios and transponder backoff terms. The spacecraft antenna is sized based on the required frequencies and beamwidth and the area of coverage for each beam is computed along with the elevation angles and uplink and downlink location losses. The other loss and noise terms are then determined from the link model.

The boundary values for the dependent and independent parameters are determined and, based on an initial design point, the vector of dependent parameters is computed. A check for boundary violation is made and an optimal perturbation of the independent parameters is determined. If convergence has not been attained the perturbed independent parameters are used to compute a new dependent parameter vector. This repeats until convergence is achieved at which time the formalized output is printed and a check is made to determine whether another case is to be run. The flow diagram of the program is shown in Figure 4.2.* (16)

In order to update the STAMP program, it was necessary to get new prices on system components to reflect changes that have occurred since the program was last used in June of 1973. The costs of transmitters, receivers and antennas were all updated by contacting appropriate manufacturers (17, 18, 19). Similarly NASA was contacted in order to acquire new launch vehicle prices (20). The launch vehicle prices used in this study are effective as of June 27, 1974. Table 4.1 lists old and new prices for some typical equipment.

Once pertinent prices were updated, one constraint in the program's input was revised; the size of antennas for the schools was limited to ten feet in diameter. This was done to insure that the program produced a ground station design which could feasibly be purchased by one school.

4.2.2 General Design Methodology

Before giving a detailed description of the satellite systems designs we will summarize the system design methodology. The STAMP

*This description was taken verbatim from Reference (16).

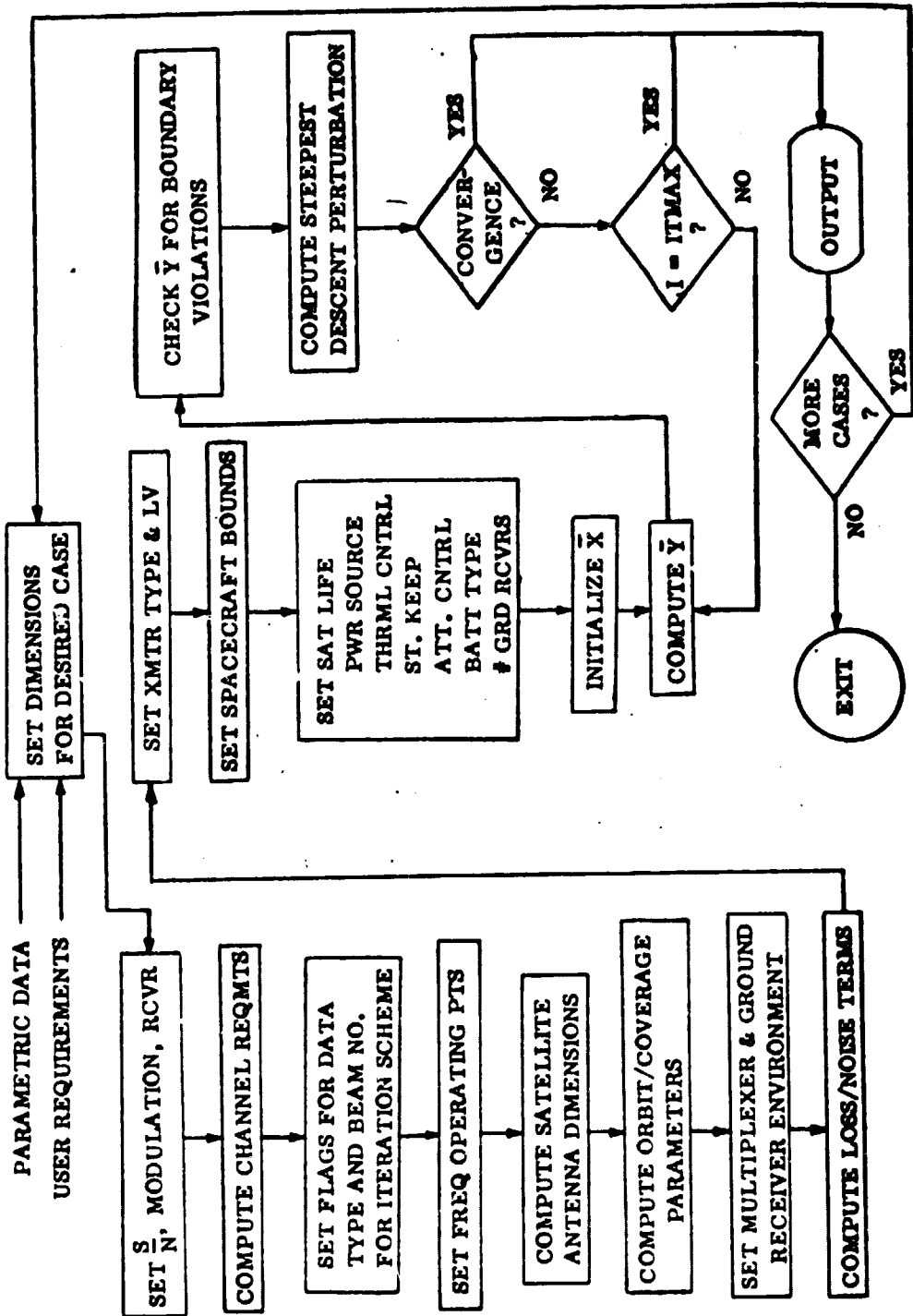

Figure 4.2: Flow Diagram of STAMP (15)

Table 4.1 Price Changes for STAMP*
(Prices in thousands of dollars)

<u>ITEM</u>	<u>OLD PRICE</u>	<u>NEW PRICE</u>
I. Boosters (20)		
SLV III-D	—	15,200
Titan III-C	22,800	26,500
Titan III-E (CENTAUR)	26,400	31,600
Saturn V	113,500	No longer available
II. Antennas (17, 19)		
Diameter (ft)		
20	6	12
10	1	5.7
5	.5	1.8
III. TRANSMITTERS (17, 18)		
1. Ground		
Power Output (Watts)		
20	12	5
50	20	15
100	30	25
2. Satellite		
20	18	15
70	40	30
400	55	50

*New Prices as of August 1974.

program requires an input deck containing 400 cards. The user need only deal with a subset of about 50 of these in order to specify his desired system to the program. Inputs that the user defines are: Booster choice, number of carriers and channels per beam, number of receiver ground stations, number of beams per satellite, channel bandwidths and satellite 3dB beamwidths, satellite and beam-center positions, data rates, modulation schemes and received SNR (signal to noise ratios). These inputs are dictated by student population density, PLATO IV communications requirements and engineering judgement.

The STAMP program computes system equipment parameters. These include: antenna sizes, transmitter powers, bandwidth expansion factors (modulation index), receiver figures of merit, satellite size, weight and lastly the costs of all system equipment and services. Costs are totaled and manipulated to reflect the time dependence of the value of money. All relevant design parameters are outputted so the designer can make judgements and rerun the process if he so decides. In fact, the designer plays an important role in the iterative process because he is responsible for specifying constraints to program outputs within "reason."

In our study, for example, STAMP wanted to place twenty-three foot diameter dish antennas at each school for the two-way satellite system. This was the choice that minimized system cost. However, one can not realistically expect to put such a large antenna with such a narrow beamwidth on every school to be served; it would be very costly and difficult to install, maintain, and aim. Hence we exercised our judgement and limited school antenna sizes to ten feet in diameter. Once the system designer is confident that the computer

output corresponds to the system he has envisioned he can use its output to compute cost/S.C.H.

4.3 DESIGN EXAMPLES

4.3.1 Description of System Coverage Model

Based on the experience of other researchers (21) and on our own results for phone line dispersed systems (22), all of which indicate prohibitive costs for serving sparsely populated areas with terrestrial links, it was decided to concentrate satellite coverage on the most sparsely populated area of the U.S. mainland, i.e., the seventeen mainland states west of Missouri. These states can be seen in Figure 4.3, and are characterized statistically in Table 4.2 (24,25). The numerical entry for each state on the map is the state's rural student population density (RSPD) (23).

We estimated the states' RSPD from census data by using the following procedure. First find the states rural population by multiplying the census figure for total state population by the percentage of the population which lives in rural areas (also given as a census datum). Dividing this rural population by the area of the state yields rural population density. This procedure neglects the area of the state which is urban, a good approximation in the western states.

To get the RSPD, we must multiply the rural population density by the percentage of rural people who are attending primary or secondary schools. This figure could not be located, so we approximated it by noting that in 1970 there were 203 million Americans, about 50 million of whom were enrolled in public schools. Therefore we

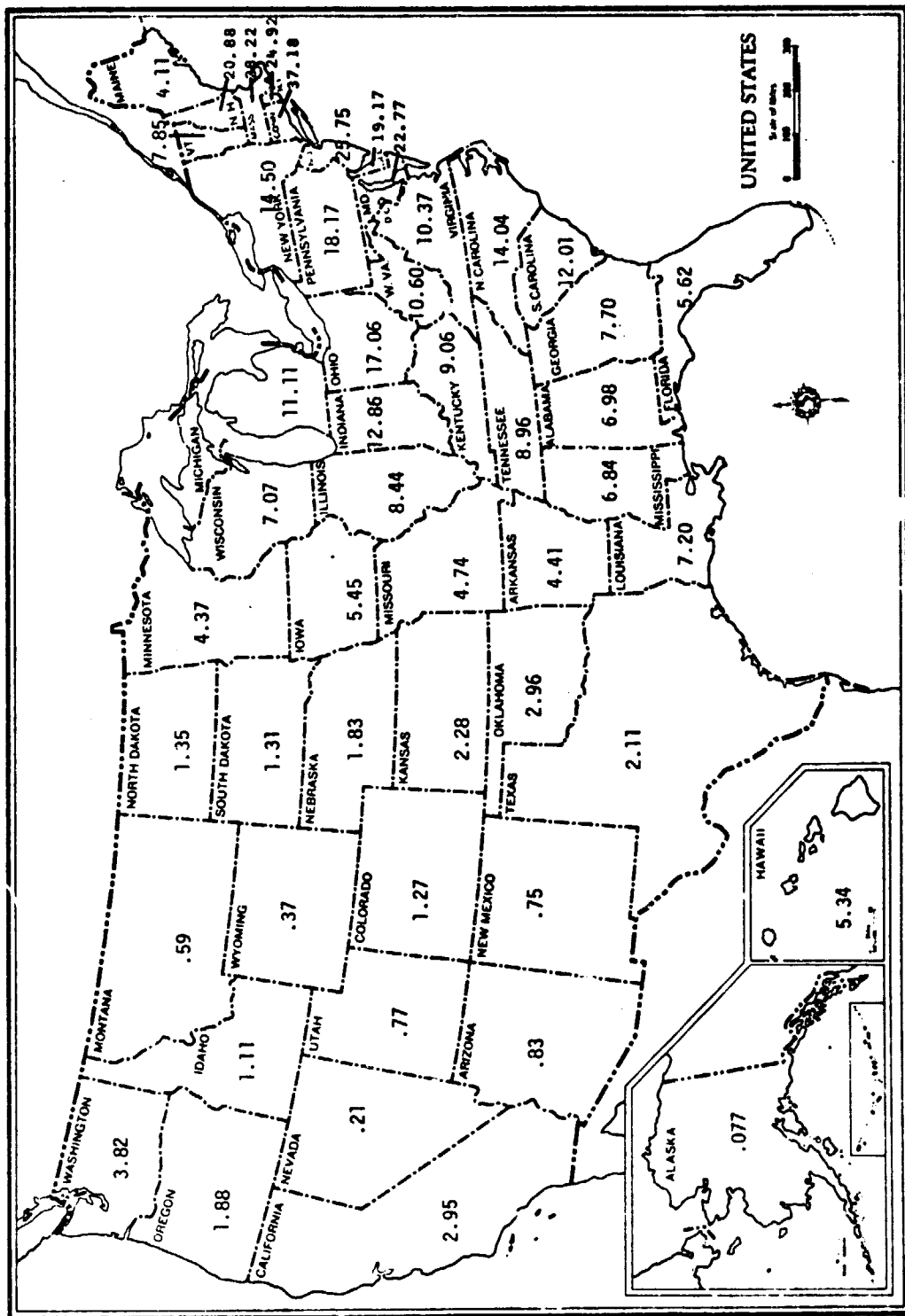

Figure 4.3: The United States by Rural Student Population Density (RSPD)

ORIGINAL PAGE IS
OF POOR QUALITY

Table 4.2 Statistical Summary of States
to be Served by Satellite System (25)

State	Number of Rural Schools	Area	Rural Student Population	Rural Student Population Density
Arizona	150	113,909	94,292	.83
California	257	158,693	462,137	2.95
Colorado	247	104,247	132,429	1.27
Idaho	255	83,557	91,869	1.11
Kansas	606	82,264	186,901	2.28
Montana	—	147,138	86,458	.59
Nebraska	765	77,227	140,027	1.83
Nevada	47	110,540	24,103	.21
New Mexico	188	121,666	91,435	.75
N. Dakota	462	70,665	94,122	1.35
Oklahoma	622	69,919	204,069	2.96
Oregon	426	96,981	181,368	1.88
S. Dakota	562	77,047	101,405	1.31
Texas	1048	267,338	553,306	2.11
Utah	110	84,916	64,301	.77
Washington	447	68,192	254,498	3.82
Wyoming	<u>158</u>	<u>97,914</u>	<u>36,186</u>	<u>.37</u>
Total	6,349	1,832,213	2,798,905	1.52

441 students/rural school

estimated that one in four rural persons is enrolled in a public school.

Thus RSPD can be computed as:

$$\text{RSPD} = \frac{\text{State Pop.} \times \% \text{ Rural} \times \% \text{ in schools}}{\text{Area of State}}$$

where the percentage in schools is estimated at 25%. Once the user population has been defined, we must decide how many PLATO systems are needed to serve the users. This figure can be computed as

$$\# \text{ of Systems} = \frac{\text{Total \# of Students} \times \text{Student duty cycle}}{\# \text{ of active terminals}}$$

where student duty cycle is defined as the ratio of time in school at the PLATO terminal to total time in school. From Table 4.1 we see that there are 2.8 million students to be served. For a PLATO IV system of 4032 active terminals and a student duty cycle of .05 (about 25 minutes per day) thirty-five systems are needed.

It should be noted that student duty cycle, as defined, is an arbitrary design parameter that influences system costs in a multiplicative manner. If one decides to double the amount of time each student spends at a terminal one would have to provide twice as many PLATO systems to cover the same number of students. The duty cycle of .05 used for our work is similar to that used by those actually using CAI systems (6).

Having computed the desired number of PLATO systems, we decide how to distribute them over the 1.8 million square mile service area. Since the technology available allows multiple beams and multiple channels per beam the design question becomes: How many beams must we use to deliver thirty-five channels? The design guideline most important in arriving at an answer is to keep the number of channels

per beam low so that inter-modulation noise is also kept low. Also, the narrower the beam, the less power must be transmitted to achieve a given signal-to-noise ratio at the ground receivers. These two factors caused us to employ seven beams of five channels each. These numbers decided, the 3dB footprints could be sketched for the seven beams as shown in Figure 4.4 assuming seven equal beamwidths.

Figure 4.5 illustrates how users in each beam can be divided into five groups, each with its own computer center. The elliptical beam has been approximated as a circle for ease in analysis. The centers of gravity of each of the five pie sections were determined for the locations of the computer centers. Computer centers are located at the centers of gravity of their service areas so that when phone line returns are used as in our first example system, the average distance from school to computer will be minimized - thus minimizing phone line costs.

Because there are about 6,350 rural school buildings in the seventeen states, there are 907 per beam and 181 per channel or per PLATO IV system. This means about 441 students and twenty-three terminals per school.

Each of the thirty-five channels broadcast from the computer center to the satellite and back is capable of transmitting the 4.8 MB/S needed for a PLATO IV system of 4032 users, quadruple the rate presently employed. As discussed in Chapter 2, the present rate of 1.2 MB/S is set by the number of users per system and is not a constraint imposed by the transmission channel bandwidth which at 6MHz is wide enough to allow a 4.8 MB/S data rate while employing the same baseband modulation scheme presently used i.e. on-off keying.

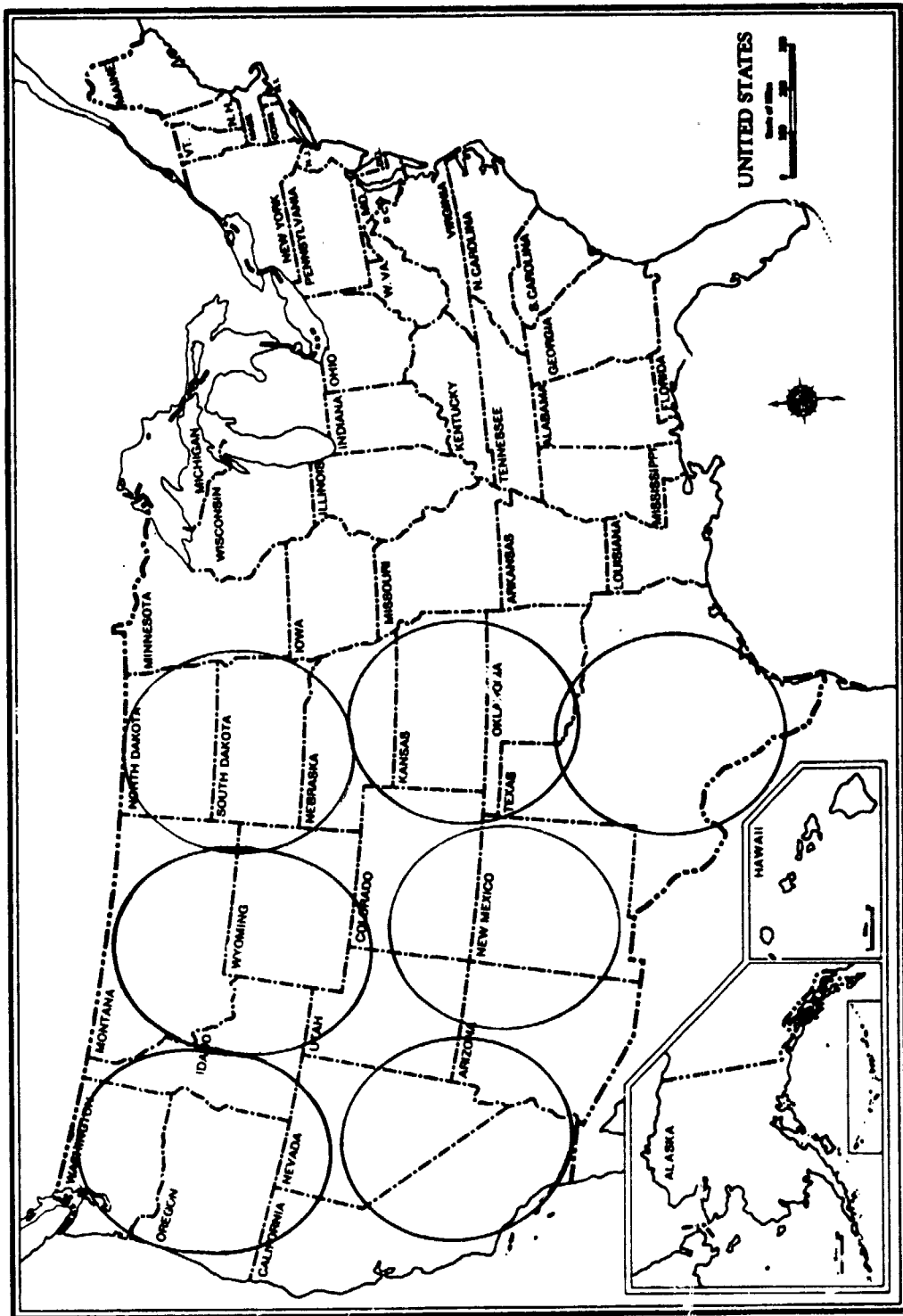
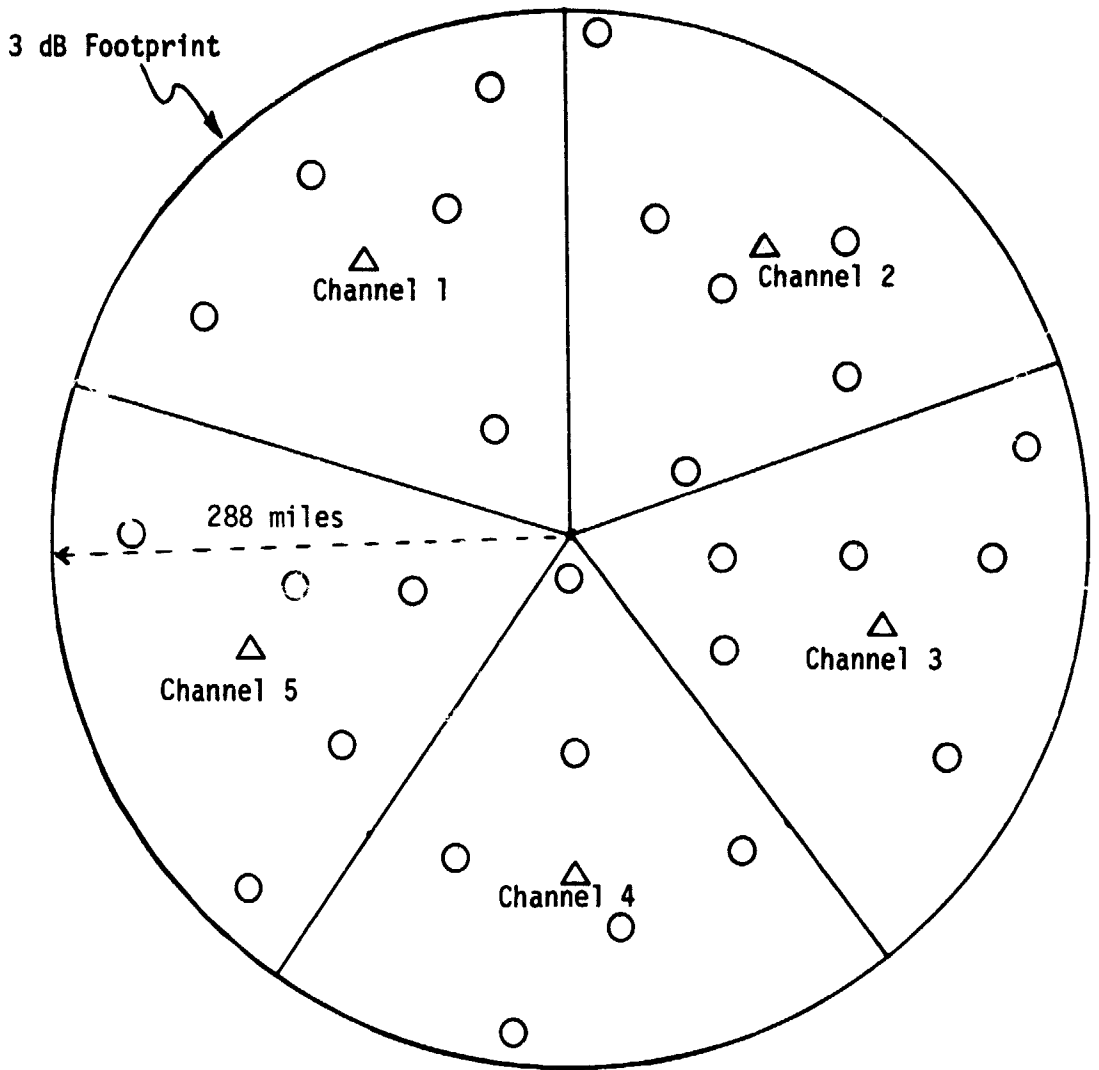

Figure 4.4: Satellite Beam 3dB Footprints



Key: \triangle Computer Center
 \circ School

Figure 4.5: Approximate Coverage Model for Each of the 7 Beams

If instead we were to assume the present forward rate of 1.2 MB/S each channel would be restricted to 1008 users or 1/4 of those possible, thus limiting system coverage to 1/4 of that possible. Total costs for the two sample systems presented here would decline slightly due to having only 1/4 as many school ground stations, but cost per student contact hour would rise due to quartering the number of paying customers. Based on the above discussion, we have adopted the assumption of a 4.8 MB/S forward data rate.

Receivers at each school have to be able to receive the appropriate one of five channels being broadcast into its region. Low cost receivers have been designed recently for this application (26, 27). Costs determined in our study are based on use of these new receivers.

4.3.2 Hybrid System (Satellite and Phone Lines)

The first example system uses the satellite to send data from the thirty-five computer centers to the 6,349 rural schools. Data sent from user terminals to the computer centers travels over leased telephone lines. One might question the validity of this approach, since we are already using half-duplex lines to the computer from the user, and we could pay 10% more to get full-duplex lines, we could eliminate the need for the satellite forward channel. This option, in fact, does not exist; data rates to and from the computer are not equal, and as pointed out in Chapter 2, thirty-two users can share one half-duplex line for return data, while a maximum of eight users can receive data over one half-duplex forward channel. Thus it is certainly worthwhile to try to circumvent the much more costly forward phone lines by satellite.

Return phone line costs for the hybrid system are easy to calculate using the results in Chapter 3. Based on census figures of 2,798,905 students in 6,349 rural schools, we arrive at a gross average number of students/rural school of 441. For a user duty cycle of .05, the "average" rural school of 441 students would have twenty-three terminals, each used 160 hours per month. This implies an average of one return phone line per school. Assuming schools are distributed uniformly, the "average" rural school is located ninety miles from its corresponding computer center. Based on the costs given in Chapter 3 for telephone lines and hardware interface equipment to connect twenty-three terminals, ninety miles away, over a half-duplex line, we arrive at a cost/S.C.H. of 50¢ for the return telephone link for the hybrid satellite system.

We design the forward link via satellite using the modified STAMP program. To do the design, we specify input parameters, derived from system user requirements, to the STAMP program so that it can compute necessary hardware specifications and costs and minimize the costs while satisfying all the requirements. In discussing the satellite system design parameters, we indicate whether they are program inputs or outputs. For clarification, these parameters will be summarized in table form at the completion of the system design description.

Figure 4.7 summarizes system parameters for the forward satellite link in the hybrid system, shown in Figure 4.6, as computed by the STAMP program. Each of the thirty-five Class I stations radiates twenty-two watts of RF power through a nine foot diameter dish antenna at 6.2 GHz with a data rate of 4.8 MB/S. The data rate and the carrier frequency are inputs to STAMP and were chosen to meet PLATO IV and FCC

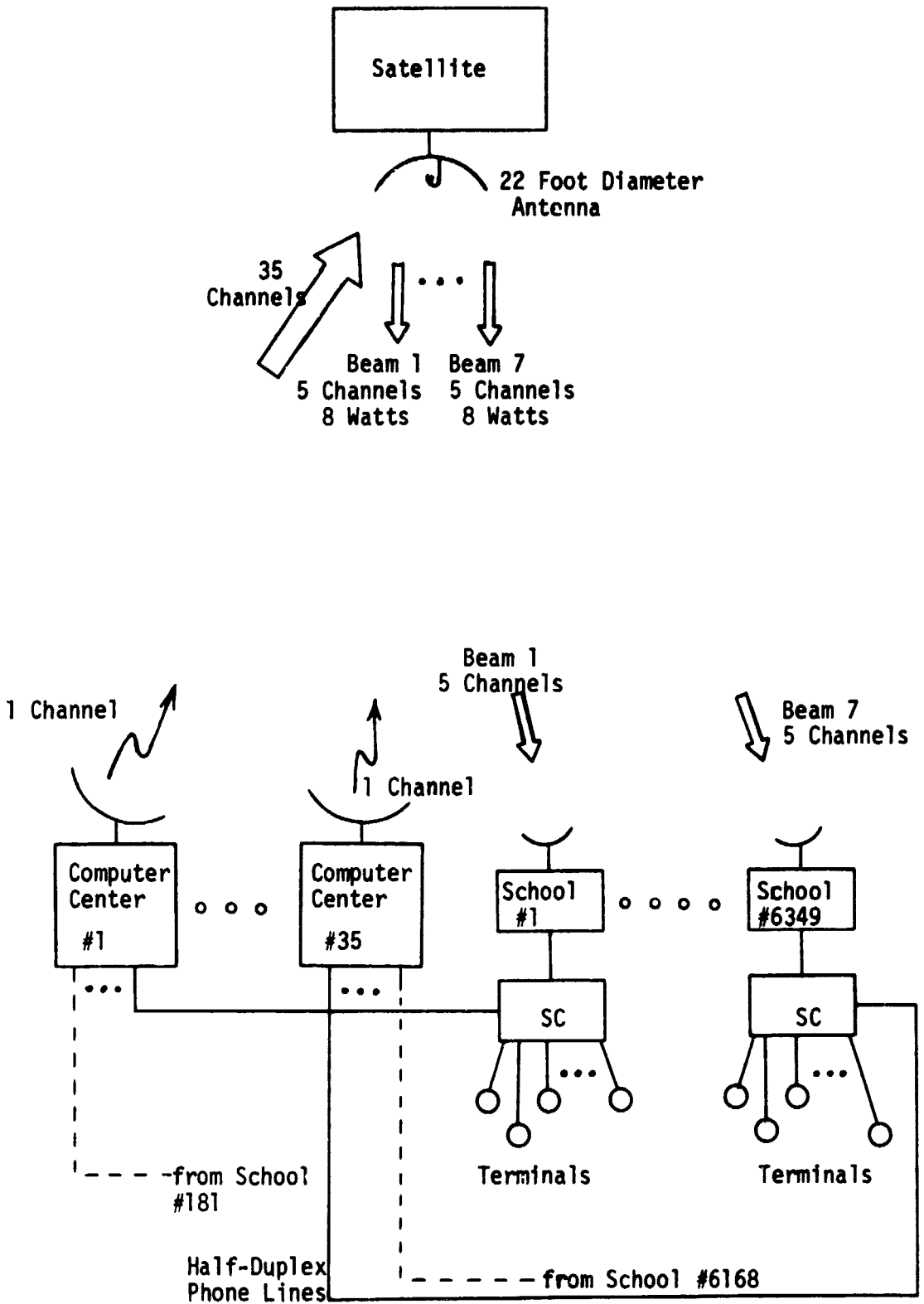

Figure 4.6: Configuration of Hybrid System

ETV/TV DISTRIBUTION

12/18/74

GROUND STATIONS - BEAM 3		(THOUSANDS)				
CLASS	FACILITIES	ACQUISITION	INSTALL	OPER/YEAR	MAINT/YEAR	TOTAL
	TEMPERATURE EQUIP-VIDEO	0.0	0.0	0.0	0.0	0.0
	TRANSmitters-VIDEO	6.18	0.93	4.35	0.67	81.66
	ANTENNA & MUX	16.19	0.0	-	1.62	40.47
	RECEIVERS	10.50	0.08	0.03	0.05	1.72
	STANDBY POWER	0.0	0.0	-	0.0	0.0
	TEST EQUIPMENT	0.0	-	-	-	0.0
	PERSONNEL	-	-	-	-	0.0
	DESIGN, INTEG & MGMT	-	3.43	-	-	3.43
	TOTAL/FACILITY	22.87	4.43	4.38	2.29	127.28
						NO FAC/BEAM = 5.
DIRECT STATIONS		TOTAL (DOLLARS)				
	ACQUISITION	INSTALL	MAINT/YR		TOTAL	
ANTENNA	362.21	128.87	36.23		1034.60	
RECEIVER	1385.94	662.97	138.56		4137.81	
	1748.25	821.79	174.82		5192.40	
						NO FAC/BEAM = 907.

Figure 4.7: Computer Output of Ground Station Design for Hybrid System

ORIGINAL PAGE IS
OF POOR QUALITY

requirements. STAMP calculated the antenna size and transmitter power. Each Class I station has a transmitter, a receiver to monitor transmissions, and an antenna. These can be purchased for \$22,870, installed for \$4,430 and operated and maintained for \$6,700 per year. The total cost for each Class I ground station over its fifteen year lifetime is \$127,280.

The direct ground stations at each school have a 6.6 foot diameter antenna and a receiver. The received signal to noise ratio is 20dB which realizes a bit error rate of 10^{-8} using frequency shift keying (28). Direct stations can be purchased for \$1,748, installed for \$821 and maintained for \$174 per year. Consequently, each direct station costs \$5,192 over its fifteen year lifetime.

Figure 4.8 is the computer output that presents the satellite component characteristics and costs. The satellite receives the signals from the thirty-five computer center ground stations and frequency translates the information from 6.2 to 2.6 GHz for broadcast to the schools through a twenty-two foot dish antenna with seven independent feeds and thus seven independent beams. Data is radiated at a power of eight watts with an EIRP of 59 dBW. This high power transmission is calculated by STAMP to minimize the size and cost of direct receiver antennas. Since a satellite lifetime is assumed to be five years, three satellites must be launched for a fifteen year system. Each satellite costs sixteen million dollars, weighs 1,655 pounds and is carried aloft by a twenty-eight million dollar Titan III-C booster.

Total system cost for fifteen years is 170.9 million dollars. To compute cost/S.C.H. we divide the total cost by the number of

ETVITY DISTRIBUTION

12/18/74

SATELLITE SUBSYSTEMS	ACQUISITION	COSTS (MILLIONS)	TOTAL	WEIGHT (LBS.)	VOLUME (CU. FT.)	TYPE	DESCRIPTIVE PARAMETERS
POWER SYSTEM	0.30	0.07	0.32	98.4	16.44	SOLAR	POWER = 0.678 KW
RECORDING POWER	-0.00	0.06	0.06	88.0	0.78	MI-CAD	CAPACITY = 1.454 KW-H
CONDUITING	0.07	0.14	0.19	9.7	1.41		
DISTRIBUTION	0.23	1.32	0.60	183.7	42.03	TRUSS	DIAM = 22.55
ANTENNA TOWER	0.08	0.42	0.10	80.0	9.98	TWT	7. TRANSMITTERS
MULTIPLIERS	1.47	0.45	0.60	158.4	26.48	WAVEGUIDE	
STRUCTURE CONTROL	0.06	0.09	0.37	0.8	16.45	LIM TRMS	NOISE FIG = 3.0 DB
STATION KEEPING	0.22	3.19	1.37	286.5	12.88	MEATPIPE	W = 1.1, D = 9.6 FT
ATTITUDE CONTROL	0.22	3.19	1.37	286.5	12.88	RESIST	PUR RAD = 0.638 KW
TELEMETRY & COMMAND	0.13	0.85	0.45	92.8	1.04	RESIST	AM/L = 372.4 SO FT
PROTOTYPE		3.29	1.10	30.0	3.00		1. PROTOTYPE(S)
INTEG. ASY & CHECK	1.60	0.97	1.49				SAT FAILURE RATE = 0.20
DESIGN, INTCG & MGMT	1.23	3.14	3.99				
CENR. SUPPORT		2.28	2.27				
GRO SUPPORT EQUIP		0.76	0.76				
TOTAL/SATELLITE	6.13	9.88	16.61	1658.4	142.67		1 ACTIVE SATELLITE
							0 ORBIT SPARE(S)
							0 GROUND SPARE(S)
							1 SALES/INTEGRATION AT ANY GIVEN TIME

LAUNCH VEHICLE	ACQUISITION	COSTS (MILLIONS)	TOTAL	WEIGHT (LBS.)	VOLUME (CU. FT.)
TOTAL/LAUNCH VEN	26.55	5.00	28.22	1800.0	1170.00
					TIT 38/CEN/2
					1 SATELLITE/LAUNCH
					LAUNCH VEHICLES
					LAUNCH VEH. FAILURE RATE = 0.25

TOTAL NUMBER OF SATELLITES LAUNCHED DURING SYSTEM LIFETIME = 3

ORIGINAL PAGE IS OF POOR QUALITY

Figure 4.8: Computer Output of Satellite Design for Hybrid System

student contact hours delivered by thirty-five PLATO IV systems of 4032 terminals each over a period of fifteen years (assuming 160 student contact hours per month and twelve months of use per year); i.e.;

$$\begin{aligned} \text{\$Cost/S.C.H.} &= \frac{\$170.9 \times 10^6}{15 \text{ yrs} \times 35 \text{ systems} \times 4032 \text{ terminals} \times 160 \text{hrs/mo} \times 12 \text{mo/yr}} \\ &= \frac{\$170.9 \times 10^6}{4.06 \times 10^9} = 4.2\text{\$/S.C.H.} \end{aligned}$$

which is surprisingly low as compared to that offered by telephone service alone. Including phone line returns, the complete system communication cost/S.C.H. is 54¢.

Relevant system parameters are summarized in Table 4.3 along with indications as to whether they were selected by the designer or computed by the STAMP program.

4.3.3 Two Way Satellite System Design

Encouraged by the low cost of the forward satellite channel, we decided to synthesize a system employing satellite channels for the return links as well.

As mentioned earlier, system coverage parameters and user requirements such as number of beams, beamwidths and bit rates comprise the computer program inputs while ground station antenna sizes and transmitter output powers are computed to satisfy the desired received signal values or more specifically bit error rates. These parameters are summarized in Table 4.4 indicating from where they came.

The second example system employs transmitters as well as receivers at the rural schools, thus eliminating the costly return phone lines. The forward link is almost the same as for the hybrid system detailed previously. It has been changed slightly in order

Table 4.3 Design Summary for Hybrid System

I. CLASS 1 EQUIPMENT	Type of Parameter	Value
Antenna size (diam.)	Computed	9.11 feet
Antenna gain	Computed	42.5dB
Transmitter power	Computed	22 watts
EIRP	Computed	52.9dBW
Receiver Noise Figure	Computed	14dB
II. Direct Station Equipment		
Antenna size (diam.)	Computed	6.6 feet
Antenna gain	Computed	32.6dB
Receiver noise figure	Computed	6.3dB
Received SNR	Input	20dB
III. Satellite Equipment		
Booster	Input	Titan III-c
Number of beams	Input	7
Number of carriers/beam	Input	5
Number of channels/carrier	Input	1
Antenna size (diam.)	Computed	22 feet
Beamwidths	Input	1.2°
Output power/beam	Computed	8 watts
EIRP	Computed	50.1dBW
Weight	Computed	1655 pounds
IV. Communications parameters		
Uplink frequency	Input	6.2 GHz
Downlink frequency	Input	2.6 GHz
Basebandwidth	Input	4.2 MHz
RF bandwidth	Computed	9.74MHz
Modulation index	Computed	.16

Table 4.4 Design Summary For Two-Way Satellite System

I. CLASS I EQUIPMENT	Input/Computed	Value
Antenna Size (diam.)	C	3.8 feet
" gain (uplink)	C	35 dB
" " (downlink)	C	27.4 dB
Transmitter power	C	194 watts
EIRP	C	54.8 dBW
Receiver Noise Figure	C	7.1 dB
Received SNR	I	20 dB
II. CLASS II EQUIPMENT		
Antenna size (diam.)	C	10.0 feet
" gain (up)	C	43 dB
" gain (down)	C	35 dB
Transmitter power	C	8 watts
EIRP	C	49.5 dBW
Receiver Noise Figure	C	13.8 dB
Received SNR	I	20 dB
III. Satellite equipment		
Booster	I	Titan III-E
# of beams	I	7
# of carriers/beam	I	5
# of channels/carrier	I	1
Beamwidths	I	1.2°
Antenna size (diam.)	C	22 feet
Output power/beam (forward)	C	3 watts
" " (return)	C	8 watts
EIRP (forward)	C	50.1 dBW
EIRP (return)	C	45.7 dBW
Weight	C	2317 pounds
IV. Communications parameters		
Uplink frequency	I	6.2 GHz
Downlink frequency	I	2.6 GHz
Modulation scheme	I	FM
Base bandwidth (forward)	I	4.2 MHz
" " (return)	I	600 KHz
RF Bandwidth (forward)	C	9.6 MHz
" " (return)	C	1.5 MHz
Mod. Index (forward)	C	.14
" " (return)	C	.24

to minimize total system cost when more complex stations are used at the schools.

Figure 4.9 summarizes pertinent parameters for the forward and reverse links as calculated by the STAMP program. Class I stations radiate 194 watts through a 3.8 foot diameter dish antenna at 6.2 GHz with a data rate of 4.8 MB/S. Each Class I station is acquired for \$27,870 and costs \$263,410 over the 15 year system lifetime.

Ground stations at each school (Class II) are acquired for \$9,430 and cost \$67,030 over the system lifetime. There are 907 Class II facilities per beam for a total of 6,349. Class II stations transmit in an (Time Division Multiple Access) TDMA mode over a 600 KHz return channel with a power of 8 watts through a 10 foot diameter dish antenna. Their EIRP is 49.5 dBW.

The satellite characteristics are given as computer output in Figure 4.10. The satellite transponders produce 3 watts/beam in the forward direction and 8 watts/beam for the return links. Each of the three satellites necessary for a 15 year system costs \$20 million, weighs 2,317 pounds, and is placed in geo-stationary orbit by a \$32 million Titan-III-E booster.

The complete system costs \$471 million which is 11.8¢/S.C.H. This figure is very encouraging when compared to alternative systems for such a large user population. Table 4.4 summarizes the system parameters and indicates whether they are inputs or outputs.

As mentioned earlier, if we assume only 1008 users per PLATO IV system the costs per student contact hour would increase and the number of users served would decrease. For the hybrid system of 1008 users per PLATO system 700,000 users could be served at a cost of

ETV/TV DISTRIBUTION									
GROUND STATIONS - BEAM 7									
(THOUSANDS)									
CLASS 1 FACILITIES	ACQUISITION	INSTALL	OPER/YEAR	MAINT/YEAR	TOTAL				
TERMINAL EQUIP-AUDIO	0.0	0.0	0.0	0.0	0.0				
-VIDEO	0.0	0.0	0.0	0.0	0.0				
TRANSMITTERS-VIDEO	16.97	2.35	12.39	1.70	230.23				
ANTENNA & MUX	4.98	0.0	0.0	0.90	22.56				
RECEIVERS	1.92	0.29	0.10	0.19	6.51				
STANDBY POWER	0.0	0.0	0.0	0.0	0.0				
TEST EQUIPMENT	0.0	0.0	0.0	0.0	0.0				
PERSONNEL	0.0	0.0	0.0	0.0	0.0				
DESIGN, INTEG & MGMT	0.0	5.18	0.0	0.0	0.0				
TOTAL/FACILITY	27.87	7.01	12.59	2.79	263.41	NO FAC/BEAM = 9.			
CLASS 2 FACILITIES	ACQUISITION	INSTALL	OPER/YEAR	MAINT/YEAR	TOTAL				
TERMINAL EQUIP-AUDIO	0.0	0.0	0.0	0.0	0.0				
-VIDEO	0.0	0.0	0.0	0.0	0.0				
TRANSMITTERS-AUDIO	3.31	0.30	2.73	0.33	49.26				
ANTENNA & MUX	3.73	0.21	0.0	0.37	14.53				
RECEIVERS	0.39	0.06	0.02	0.04	1.33				
STANDBY POWER	0.0	0.0	0.0	0.0	0.0				
TEST EQUIPMENT	0.0	0.0	0.0	0.0	0.0				
PERSONNEL	0.0	0.0	0.0	0.0	0.0				
DESIGN, INTEG & MGMT	0.0	1.51	0.0	0.0	1.41				
TOTAL/FACILITY	9.53	2.18	2.79	0.94	67.03	NO FAC/BEAM = 907.			

Figure 4.9: Computer Output of Ground Station Design for Pure Satellite System

ORIGINAL PAGE IS
OF POOR QUALITY

ORIGINAL PAGE IS
OF POOR QUALITY

1/ 3/75

ETV/ITY DISTRIBUTION

SATELLITE SUBSYSTEMS	ACQUISITION	COSTS (MILLIONS)	TOTAL	WEIGHT (LBS.)	VOLUME (CU FT)	TYPE	DESCRIPTIVE PARAMETERS
POWER SUBSYSTEM	0.38	0.08	0.46	127.2	21.28	SOLAR	POWER = 0.890 KW
PROPULSION	0.00	0.00	0.00	172.7	1.03	NI-CAD	CAPACITY = 1.909 KM-H
TELEMETRY	0.03	0.07	0.10	12.7	1.09		
CONTROL	0.08	0.16	0.24	18.7	42.03	TRUSS	DIAM = 22.03; 7 BEAMS
TELETYPE	1.01	0.58	1.59	118.6	19.95	TWT	14. TRANSMITTERS
MULTIPLEXER	0.23	0.35	0.58	242.0	8.18	WAVEGUIDE	
RECEIVERS	2.33	0.57	2.90	732.0	24.67	LIN TRNS	NOISE FIG = 3.0 DB
STRUCTURE	0.18	1.68	1.86	170.0	38.89	HEATPIPE	M = 1.32 D = 9.0 FT
STATION KEEPING	0.06	0.69	0.75	0.3	0.10	RESIST	
ATTITUDE CONTROL	0.21	0.69	0.90	40.0	18.05	RESIST	
TELETYPE & COMMAND	0.23	3.20	3.43	63.7	1.05	RESIST	AM/L = 488.9 SQ FT
PROTOTYPE	0.17	4.86	5.03	70.0	2.00		
INTEGRASSY & CHECK	2.05		1.62				1 PROTOTYPE(S)
DESIGN, INTEG & MGMT		9.62	3.21				SAT FAILURE RATE = 0.20
CENTER SUPPORT	1.79	3.37	5.16				
GRD SUPPORT EQUIP		3.33	1.11				
TOTAL/SATELLITE	0.97	11.33	20.30	2317.6	180.21		1 ACTIVE SATEL(S) 0 PROTOTYPE(S) 0 GROUND SPARE(S) 1 SATEL(S) IN STORE AT ANY GIVEN TIME

LAUNCH VEHICLE	ACQUISITION	COSTS (MILLIONS)	TOTAL	WEIGHT (LBS.)	VOLUME (CU FT)	TITAN 3D/82	SATS/LAUNCH
TOTAL/LAUNCH VEH	31.60	2.20	32.33	2800.0	1170.00	1	1 LAUNCH VEHICLES LAUNCH VEH FAILURE RATE = 0.25

TOTAL NUMBER OF SATELLITES LAUNCHED DURING SYSTEM LIFETIME = 3

Figure 4.10: Computer Output of Satellite Design for Pure Satellite System

66¢/S.C.H. The pure satellite system would also serve 700,000 users but would cost 24¢/S.C.H. for a 1008 user systems.

4.4 SUMMARY AND CONCLUSIONS

We computed in this chapter the communications costs for satellite-dispersed PLATO IV systems for a realistic user group, and they compared quite favorably to costs incurred in using alternative communications technologies. We showed that a hybrid system employing satellite forward channels and telephone line return channels could serve the 2.8 million students in the rural schools of the seventeen mainland United States west of Missouri for a communications cost/S.C.H. of 54¢. We also saw that a pure satellite system employing both forward and return satellite channels could serve the same user population for 11.8¢/S.C.H. These costs were given as results of two detailed system designs employing the STAMP computer program as a design tool.

The main difficulty in realizing a system such as the pure satellite one is that it would involve an agreement between all of the seventeen states to be served. This would perhaps be difficult to achieve. The technology is available to achieve low cost/S.C.H., but ultimately the satellite system's success will depend on cooperation between the users in such a large service area.

5. RADIO DISTRIBUTION OF PLATO IV

5.1 INTRODUCTION

This chapter assesses the application of UHF radio broadcast techniques to satisfy the communications requirements of large interactive CAI systems such as PLATO IV. First we discuss two available transmission technologies to distribute PLATO IV, UHF TV and low-power microwave broadcast. We also describe a means of extending the limited range of the two systems to serve more sparsely populated areas by employing repeaters. We then apply these techniques in six network designs and calculate and compare communication costs. These costs are given as functions of the number of remote sites (schools).

As in previous chapters, cost/S.C.H. is computed as:

$$\frac{\text{Total Cost}}{4032 \times 160 \times 12 \times L} \tag{5.1}$$

for a PLATO IV system with 4032 active terminals used 160 hours per month and 12 months per year for L years.

Both systems described in this chapter broadcast data from the computer in the TV format that the NIU output uses, modified to contain data for 4032 users rather than 1008. Thus each remote site requires a site controller to demultiplex data from the wideband TV signal.

Radio computer communications systems, similar to those proposed here are presently being evaluated on experimental bases at the University of Illinois' PLATO IV system in Champaign-Urbana (30).

5.2 PRESENTLY AVAILABLE RADIO BROADCAST TECHNOLOGIES

5.2.1 Broadcast UHF Television

Reaching fairly large numbers of remote receivers with a wideband signal is a task well suited to conventional TV broadcast systems.

This fact has inspired us to consider using a UHF TV channel to serve a PLATO system in the computer-to-user direction. Since broadcast UHF TV equipment is commonplace, very little development work needs to be done to adapt existing systems to systems capable of broadcasting PLATO IV data. The high power of UHF TV transmitters enables the use of unsophisticated receivers at large distances. It is not uncommon to receive UHF TV channels more than fifty miles from the originating station.

Economics has forced the present TV broadcast system to employ cheap receivers and expensive transmitting stations. Costs (and hardware sophistication) of transmitters and receivers are set based upon the net effect each has on total system cost. In the commercial TV market, there are millions of receivers for each transmitter, which dictates that a very expensive transmission station should be used in order to ensure minimum costs at the receivers and thus minimal total system cost. Thus we see multimillion dollar TV stations transmitting the maximum power allowed by the FCC. Similarly, transmitter antennas are tall and expensive to reach the largest possible audience.

One PLATO IV system might have say, one hundred receivers and one transmitter. This estimate assumes that 80,000 students share 4032 terminals and that there are 800 students per receiver site. (Throughout this discussion it is assumed that there is one receiver at each school.) This ratio of 100 receivers to one transmitter implies that, although the transmitter should cost more than a receiver in an optimal system, it need not cost thousands of times more as in the commercial broadcast industry. However, despite the sub-optimum

cost ratio for conventional broadcast UHF TV system equipment for the PLATO application, they can be used to realize an economical forward communications channel for PLATO IV, as we shall see.

5.2.2 Omni-Directional Microwave Broadcast

In the past few years, a new type of wideband (TV) distribution has been implemented which has a much lower transmitter cost to receiver cost ratio. This system, which is sometimes called MDS (Multipoint Distribution Service), employs a low-power microwave radio transmitter broadcasting through an omnidirectional antenna to high gain receiver antennas.* This type of system is designed for fewer receivers than the commercial UHF TV systems, and this fact is reflected in the transmitter/receiver cost ratio. A MDS system uses a \$15,000 transmitter and \$1,500 receivers (31). Thus, one factor which influences the decision between microwave MDS and UHF TV is the number of remote sites to be reached; the transmitter/receiver cost ratio determines which is least expensive.

Another factor is range. The low-power microwave systems need an unobstructed line of sight path between the transmitter and the receiver. This requires that no buildings, hills, trees, or mountains be in the visual path between the transmitter and receiver antennas. Although microwave radiation propagates similarly to light, it requires some clearance over an obstruction. With a clearance of about 0.6 of a "Fresnel Zone," a term we define below, about half the power is lost,

*At the University of Illinois an MDS channel is currently being operated to carry data to PLATO IV sites within 15 miles of the central computer in the Champaign-Urbana area (30).

and obstructions with less clearance cause the received signal power to decrease rapidly.

The size of the Fresnel Zone (F) is related to the carrier frequency (f in MHz), the distance from the obstacle to the transmitter site (d₁) and the total path length (D) by:

$$F = 1370 \sqrt{\frac{d_1 d_2}{fD}}$$

For a 40 mile transmission path (D = 40), the beam center should clear an obstacle located at mid path (d₁ = d₂ = 20) by 100 feet at a 2 GHz transmission frequency (f = 2 x 10³) (32).

In order to reach users blocked by obstacles, repeaters can be employed. A repeater consists of a transmitter, receiver, associated antennas, and a tower upon which this equipment is mounted. It must be emphasized that the utility and cost effectiveness of using MDS systems for forward PLATO IV channels is strongly dependent upon the terrain of the service area. If an unobstructed path can be achieved, either by using repeaters or tall antenna towers (rented space on a tall building, for example), then the MDS system can be reliable for distances up to 40 miles or more (33).

5.3 TWO NETWORK DESIGNS FOR PLATO DELIVERY

In this section, we propose and analyze two schemes for distributing PLATO IV. The first uses UHF TV transmission techniques in the forward direction and low power, medium bandwidth radio transmitters for the return transmissions. The second system, which uses the same return transmission technique as the first, uses low-power microwave transmission in the forward direction. We calculate equipment costs, total system cost and cost/S.C.H. for each of the two systems. We

also indicate range limitations for each system and compute cost/S.C.H. as a function of the number of remote receiver sites (schools).

5.3.1 Network Employing UHF TV Broadcast

The UHF TV system has one central transmitting station that sends data to a number, S , of schools which must be within about 70 miles of the transmitter. Each school has $\frac{4032}{S}$ terminals in it, all of which receive data from a single UHF TV receiver. The terminals are connected in groups of 32 or fewer to site controllers, and each site controller is connected to the UHF receiver. Figure 5.1 illustrates the equipment layout at the central computer and school sites.

5.3.1.1 Forward Channel Equipment

The computer center equipment includes a RCA 30KW UHF TV transmitter, an antenna, and a 1,000 foot tower for broadcasting data to remote users up to 70 miles away. We use the 30KW transmitter because it is the least expensive and least powerful one available. The 30KW transmitter costs \$285,000 from RCA and a suitable antenna and tower costs \$340,000 (34). For receiving return data, the computer center also needs a receiver, which we will describe when we discuss the return channel.

Each school requires a conventional UHF TV receiver, antenna and a site controller for the forward channel. In addition, for the return channel, each school must have a low power, medium bandwidth transmitter and a transmission antenna. Adequate UHF TV receivers can be purchased for under \$100 at department stores (35), while the receiver antenna cost can range from zero (for a loop supplied with the TV) to \$50 for a multiple element, high gain antenna. Modification of the TV receiver for PLATO IV use is accomplished by tapping a

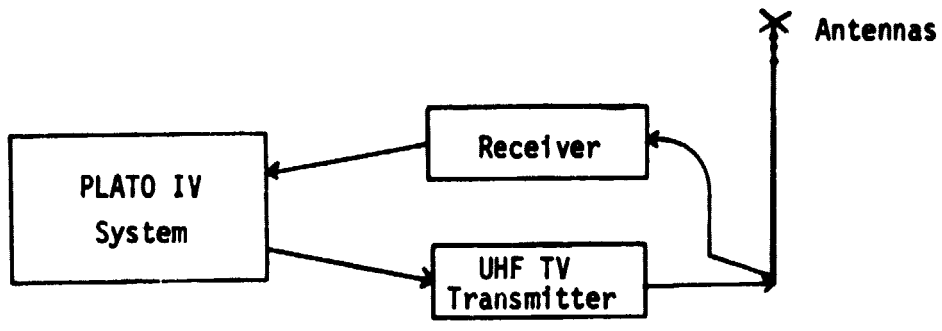

a) Computer site equipment

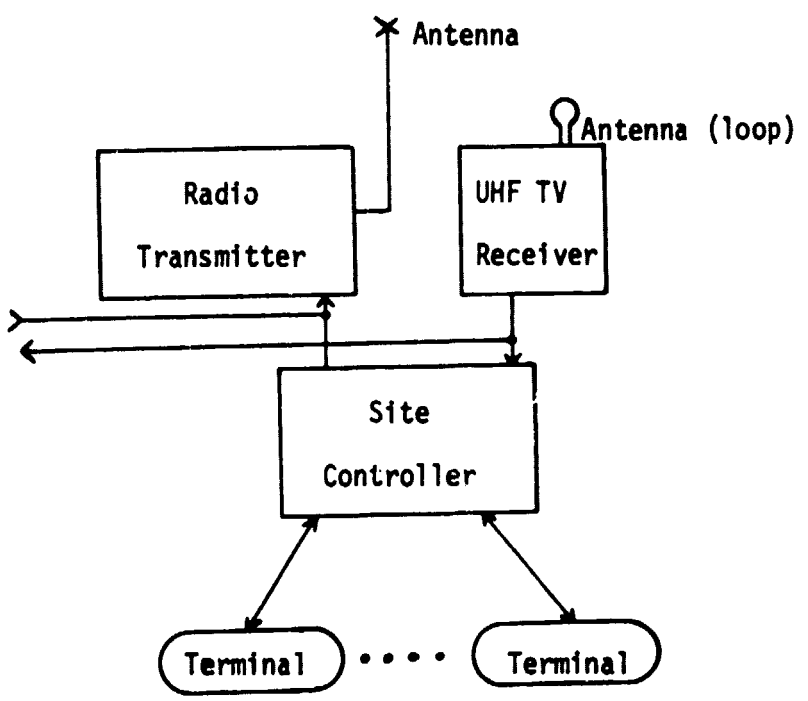

b) School site equipment

Figure 5.1: Equipment at a) Computer and b) School Sites for UHF TV Broadcast System

wire into the video output signal to route data to the site controller, which demodulates the TV formatted signal and distributes data to the terminals it serves.

Indeed, there are many portions of the standard TV receiver that are not needed. These include the picture tube, horizontal and vertical deflection circuits, audio circuit, VHF tuner and high voltage power supply. All that our system requires is the UHF tuner, intermediate-frequency strip and video detector. A receiver consisting of these items could easily be mass produced for less than \$50 (36).

Antenna choice is dependent upon received signal power, which is related to distance from the transmitter and also is influenced by the topography of the transmission path. Determining the actual signal strength at a specific receiver location is a matter of accounting for various losses and gains along the signal route (31). The 30KW transmitter radiates a power of 45dBW through its antenna, which has a gain of 14dB for an EIRP of 59dBW. At a distance of one mile, the signal's free space loss is 90dB, and each time the path length is doubled another 6dB loss is encountered. Thus at a distance of four miles, the received signal power is $59-90-12 = -43$ dBW. A TV receiver with a sensitivity factor of 100dB can theoretically receive reliable data (20dB signal-to-noise ratio) at a distance of 285 miles from the transmitter with no receiver antenna gain. In practice, however, the lay of the land and the curvature of the Earth makes it necessary to use antennas with gain for receivers located 20 miles or more from the transmitter. In fact, antenna heights and topography of the transmission path determines a practical system's range more often than does the transmitter's output power.

5.3.1.2 Return Channel Requirements and Equipment

Before discussing necessary return channel equipment, we shall review the channel requirements. In order to allow 4032 users to send 150 bits of data per second over the return channel, the channel must be capable of transmitting at least 600KB/S. This calculation assumes that a synchronous, time-division-multiple-access technique is employed to share the channel equally among all 4032 users.

The inherent synchronization associated with TDMA channels can be accomplished by slaving return transmissions to a timing signal derived from the received forward channel sync signals as is presently done by the site controller. The only modification necessary is to change the multiplexing and data rate out of the data concentrator portion of the site controller. This change is needed because the return is a 600KB/S channel shared by all site controllers and users rather than the present multiple 4800B/S return channels shared by only 32 users through one site controller each.

Continuing our discussion of return channel design requirements, the received signal-to-noise ratio should be large enough to realize a bit error rate of 10^{-5} or less. With a noncoherent channel decoder at the receiver, a received E_b/N_0 (energy per bit to noise ratio) of 20dB will suffice (28). The radiated carrier power (P_t), antenna gains (G_T , G_R), free space path loss (L_{fs}), bit rate B_r , receiver effective noise temperature (T_{eff}) and received E_b/N_0 over an unobstructed path are related theoretically by (37):

$$\frac{E_b}{N_0} = \frac{P_T G_T G_R}{K T_{eff} B_r L_{fs}} \quad (5.2)$$

where K is Boltzman's constant. (5.2) is more useful when expressed

in decibel form:

$$E_b/N_0 \text{ (dB)} = P_T \text{ (dBW)} + G_T \text{ (dB)} + G_R \text{ (dB)} - L_{fs} \text{ (dB)} - K T_{\text{eff}} B_r \text{ (DBW)} \quad (5.3)$$

where dBW implies dB relative to one watt. Setting $G_T = G_{dB}$, $G_R = 10_{dB}$, $T_{\text{eff}} = 5,000^\circ\text{K}$ and $B_r = 600 \times 10^3$ in (5.3), we arrive at the following relationship:

$$E_b/N_0 \text{ (dB)} = P_T \text{ (dBW)} + 16_{dB} - L_{fs} \text{ (dB)} + i34_{dBW} \quad (5.4)$$

Using the fact that $L_{fs} \text{ (dB)} = 36.6 + 20 \text{ Log}_{10} f + 20 \text{ Log}_{10} d$ (37)

(where f is the carrier frequency in megahertz and d is the path distance in statute miles) we see that for $f = 500$ and $d = 70$, $L_{fs} = 127_{dB}$.

Thus E_b/N_0 and P_T are related by:

$$E_b/N_0 \text{ (dB)} = P_T \text{ (dBW)} + 23_{dB} \quad (5.5)$$

which indicates that a 10 watt (10dBW) transmitter can theoretically be received at a distance of 70 miles with an E_b/N_0 of 33dB. This value of E_b/N_0 will insure a bit error rate below 10^{-5} with a fade margin (signal excess) of 13dB. In order to attain this performance, the path must be fairly clear. Thus we have chosen a 1,000 foot antenna tower at the main computer station for the UHF system so that both forward and return transmissions will be reliably received up to 70 miles away.

Antenna towers at the schools are assumed to be 30 feet tall for both UHF and microwave systems. No costs were assessed for these towers because the antennas can be mounted on top of the school buildings which are assumed to be 30 feet or more above the surrounding ground.

If the necessary return channel can be secured from the FCC, equipment could readily be developed using state-of-the-art electronic

circuits. For example, the Repco Company of Orlando, Florida offers transmitter and receiver subsystem modules from which can be constructed a 600 KHz (KB/S), 10 watt transmitter for under \$600.00 in single quantities (38). For a hundred or more, the price falls to about \$500 per unit. The transmission antenna can be purchased for \$100. Thus each school needs \$600 worth of equipment to send data back to the computers and \$100-\$150 worth to receive data.

The receiver to be located at the computer center can also be constructed from Repco electronic modules for \$400 plus \$100 for its antenna. The central receiver antenna can be mounted on the 1,000 foot transmitter antenna tower and thus can receive from users up to 70 miles away. Thus the central site has about \$625,000 worth of equipment.

3.1.3 Channel Allocation from the FCC

The low power (≤ 10 watts), medium bandwidth (600 KHz) transmitter and receiver needed to send data from remote sites to the computer center is not presently a commercially available item. To date, the FCC (Federal Communications Commission) has not allocated channels for data transmission of the type described above. Since the FCC decides what the future of communications is to be, any innovative use of the radio frequency spectrum has to be licensed by the FCC. Researchers at the University of Hawaii's ALOHA system have succeeded in obtaining two 100 KHz wide radio channels from the FCC on an experimental basis (38). These channels are being used as data links between the University's central computing facilities and remote terminals located throughout Hawaii. Thus the FCC has been persuaded

to give medium bandwidth data communications a chance to prove its usefulness.

One possible approach to the FCC for the purpose of securing a forward and a reverse channel to be used to distribute one PLATO IV system would be to file for the use of two UHF TV channels. Since these channels are 6MHz wide, the return channel modulation technique could be one employing bandwidth expansion to reduce necessary power requirements. Minimizing radiated power on the return channel would cut the cost of the transmitters located at each remote site, and might help to allay FCC fears that one or more of the many return transmitters could malfunction and transmit data at the wrong frequency, interfering with other bands in the frequency spectrum.

5.3.1.4 UHF TV System Cost

Total system cost is $\$625,000 + S (\$700)$, where S is the number of schools (remote receiver sites) in the PLATO IV system. Because the central station cost is about 900 times as large as the remote site costs, we see that system cost does not vary strongly with varying S (and thus with varying student population density). For example, a system with 50 schools costs $\$660,000$ while one with 200 schools costs $\$765,000$. Computing $\text{Cost}/\text{S.C.H.}$ by (5.1) gives $8.5¢/L$ and $9.9¢/L$ where L is system lifetime in years. For $L = 5$ these costs are both less than $2¢/\text{S.C.H.}$

When a school is located in an obstructed signal zone, so that it can not send an acceptable signal back to the computer, repeaters can be employed to "fill in" the service area. Each "fill in" repeater would cost about $\$2,800$; $\$1,000$ for the receiver and transmitter and $\$1,800$ for a 50 foot tower. Most users' transmissions sent from

within 70 miles of the computer center will be received with good bit-error-rates (10^{-5}) without use of repeaters. Even the cost of return channel repeaters is not a significant portion of total system cost. In the forward direction, signal strength even in valleys will be sufficient to receive data reliably because of the high-power TV transmitter.

5.3.2 Network Employing Microwave Broadcast

This section designs and costs a delivery network which uses low-power microwave broadcast in the forward channel and the same return channel equipment as the UHF TV system design in the previous section. The equipment block diagram is given in Figure 5.2. The conventional TV transmitter, receivers and antennas have been replaced by MDS microwave equipment as shown in Figure 5.2. Recall that the important constraint for using this equipment is that there be an unobstructed line of sight path from the transmitter antenna to the receiver antenna. Thus this system can be used only where the topography allows. Using suitably tall antennas, this path can be as long as 40 miles (31).

Data is sent in TV format on a microwave carrier frequency (2150 MHz) at a radiated power of 10 watts from an omnidirectional antenna atop a 400 foot tower to high gain (26dB), 4 ft dish antennas at the remote sites. Each site needs a receiver/downconverter to extract the received TV channel from the microwave carrier for input to the site controller.

We can estimate the system cost from manufacturers' literature. One company that offers the necessary equipment for the forward channel

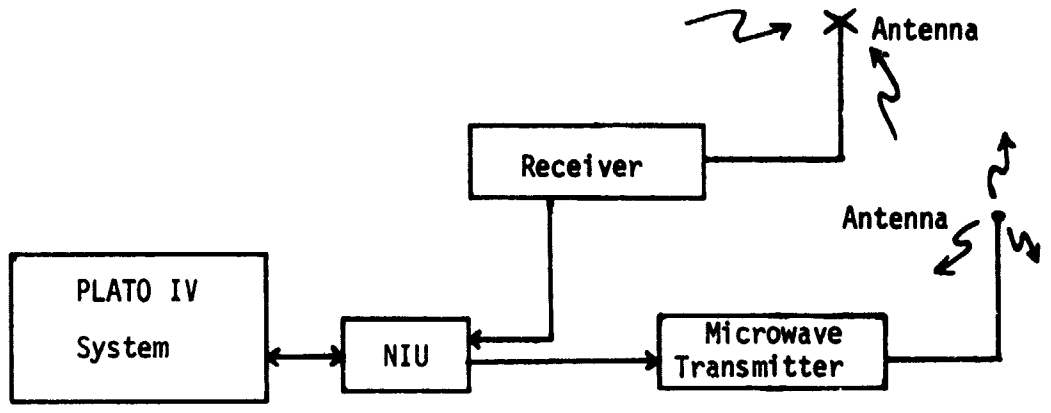

a) Computer site equipment

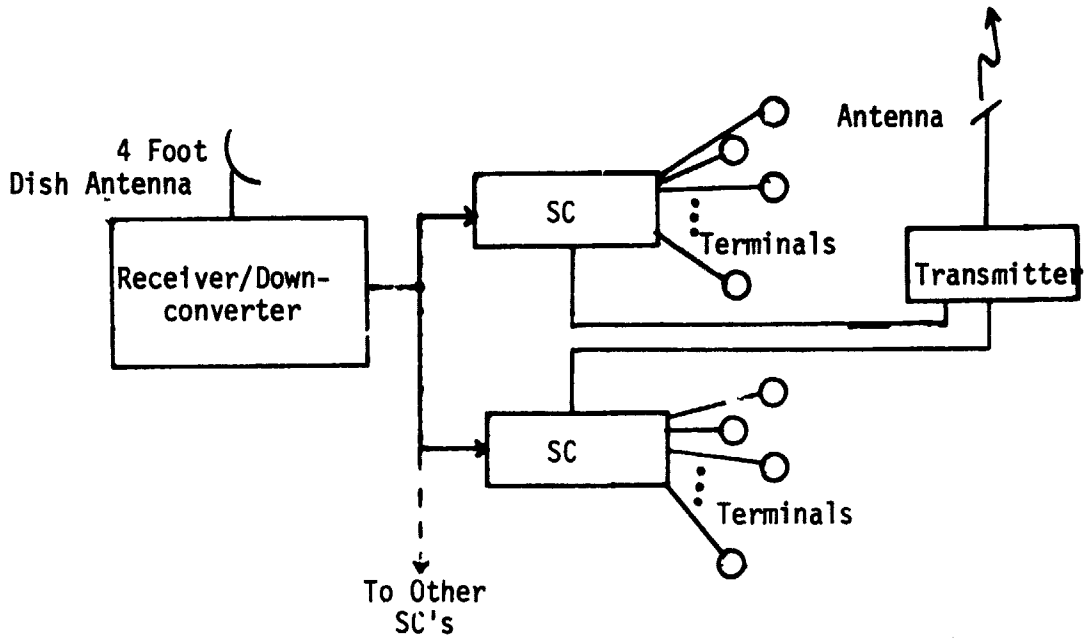

b) School site equipment

Figure 5.2: Equipment at a) Computer and b) School Sites for Microwave Broadcast System

is MICROBAND Inc. of New York City. From this company, a transmitter and antenna cost \$15,000, the 400 foot transmitter tower costs about \$10,000 and the remote receiver/down converter plus a four foot diameter dish antenna costs \$1,450 each in quantities of 50 units (32).

The central computer site has its antennas mounted on a 400 foot tower to achieve forward and return ranges of 40 miles with 10 watt transmitters. The reduction in range from UHF TV's 70 miles to microwave's 40 miles is due to lower tower height and lower transmitter power (400 feet versus 1,000 foot towers and 10 watt versus 30 KW transmitter power).

Total equipment cost at the central transmission site is \$25,500; \$25,000 for the forward channel electronic equipment and \$500 for the receiver equipment. Each school has \$1,450 worth of receiver equipment and \$700 worth of transmitter equipment. Total system cost comes to $\$25,500 + S (\$2,150)$. Note the strong dependence of system cost on S. Using equation (5.1) we compute the costs/S.C.H. of two systems; one with 50 schools and one with 200 schools. Costs/S.C.H. are 1.7¢/L and 5.9¢/L. A lifetime of 5 years implies costs/S.C.H. of .34¢ and 1.2¢. As in the UHF TV system, repeaters can be used to "fill in" poor reception areas. Due to the lower power of the microwave system forward and return channels fill in repeaters need be bidirectional. The forward channel repeater costs \$16,450; \$15,000 for the transmitter and antenna and \$1,450 for the receiver/down-converter. The return channel repeater costs \$1,000 (for its receiver/transmitter and antenna). An antenna tower 400 feet tall costs about \$10,000 so the total "fill in" repeater cost is about \$27,450.

5.4 COMPARISON OF UHF TV AND MICROWAVE SYSTEMS

Costs computed in the previous sections are graphed as functions of S (the number of remote schools in the system) in Figure 5.3. The graphs assume no repeaters are used and represent circular service areas with radii of 70 miles for UHF TV and 40 miles for microwave.

Repeaters could be employed to extend the system coverage area. Repeaters would be located at the outer edge of the primary reception zone and would radiate signals according to the antenna patterns shown in Figure 5.4 (39). The system coverage patterns in Figure 5.4 indicate how five repeaters can be used to nearly double the radius of the coverage area. The equipment configurations for extended systems is shown in Figure 5.5.

When using repeaters, one needs to avoid multipath problems that arise when multiple transmitters transmit the same signal on one channel. The multiple emitters cause the receiver to receive multiple "copies" of the transmitted signal, each with a different propagation delay and signal strength.

One solution to the multipath problem is to translate the signal in frequency at the repeater, i.e. to receive the transmission from the central transmitter on channel A and then shift it to channel B for rebroadcast to the extended service area. Receivers at the remote sites would then tune to whichever channel gives the strongest signal in their area.

The problem with frequency translation is that several channels are required, and therefore the frequency spectrum is used inefficiently.

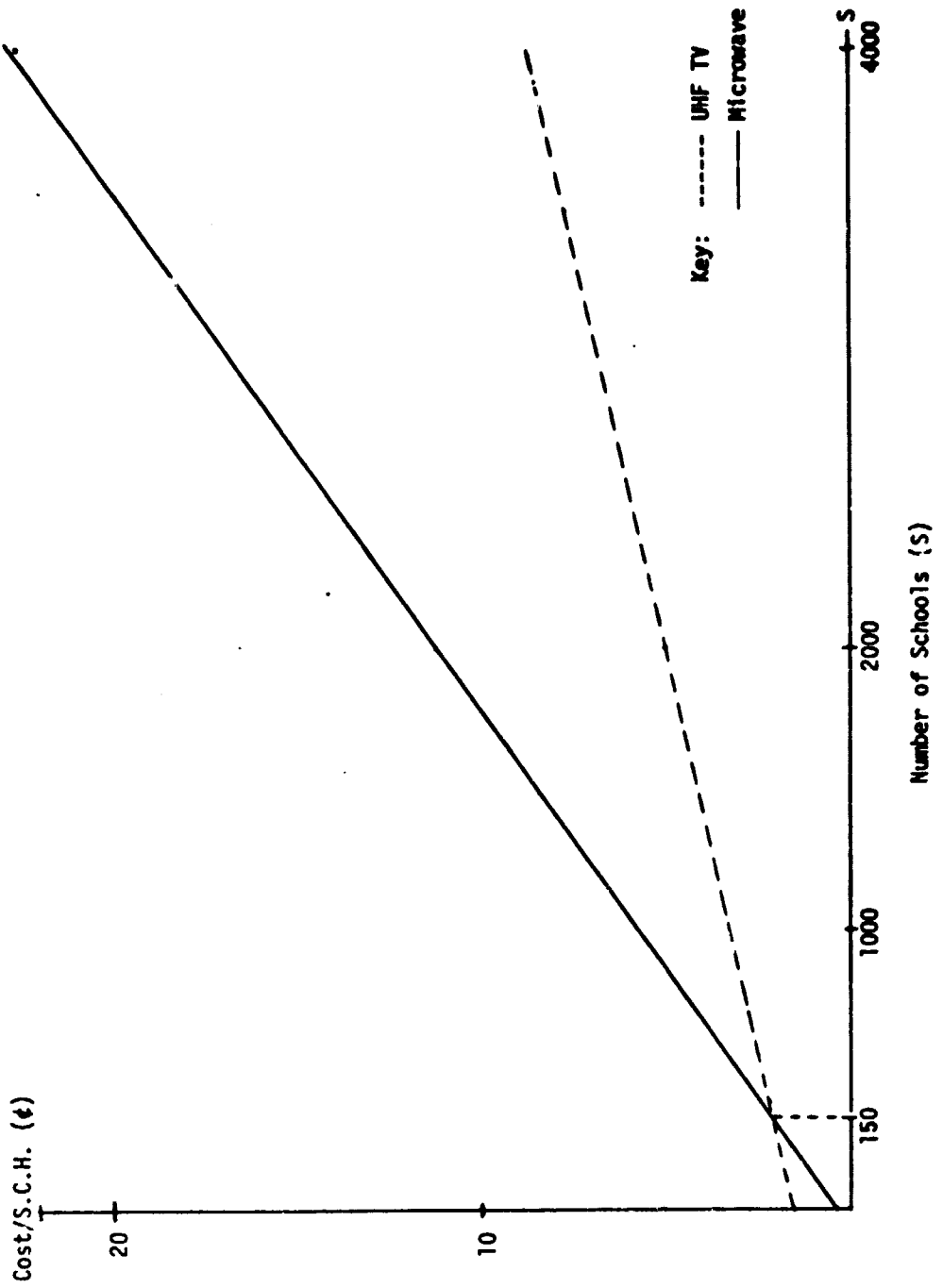
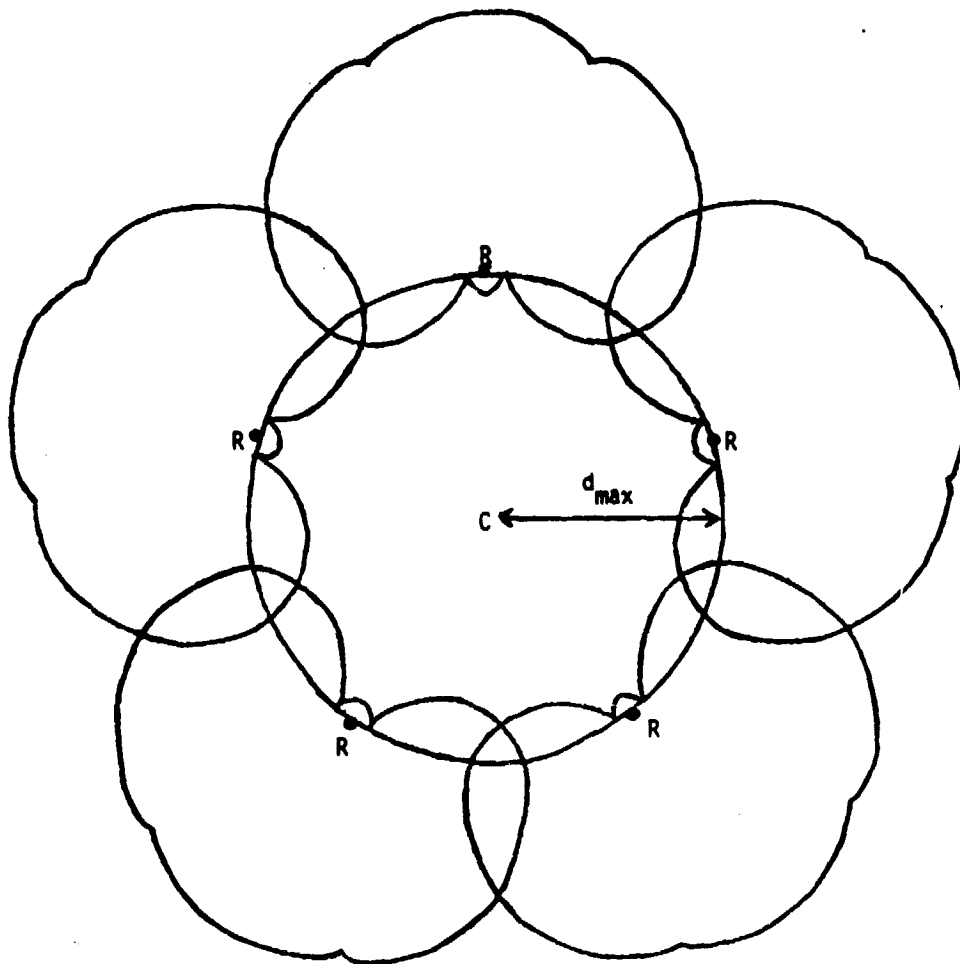

Figure 5.3: Communication Costs of UHF TV and Microwave Systems (L=5 years)



Key: R=Repeater Station

C=Computer Center

Figure 5.4: Antenna Patterns for Extended Coverage Systems

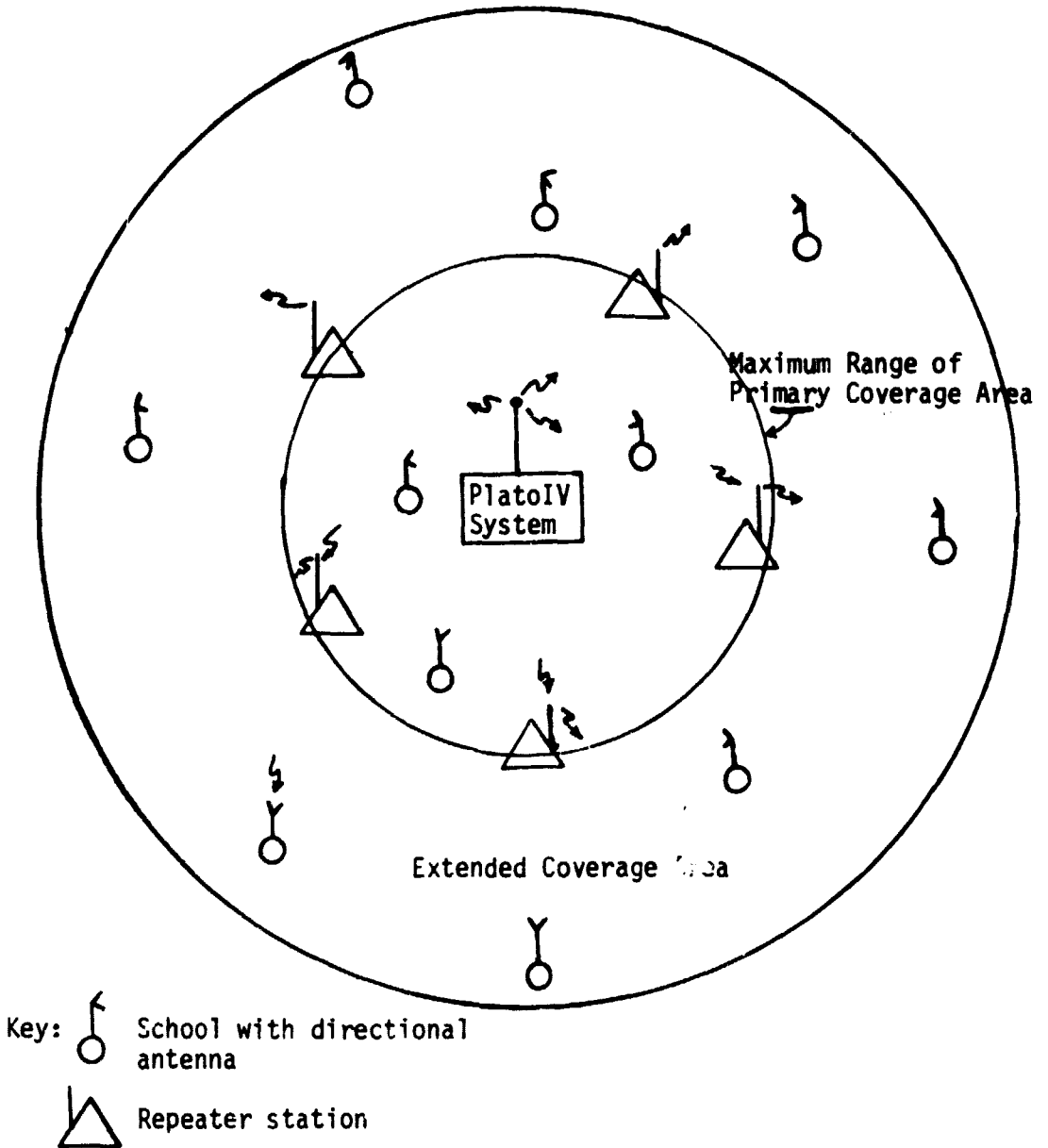

Figure 5.5: Extended Coverage Equipment Configuration

Another solution to the multipath problem is to use directional antennas at the remote sites. By "aiming" the receiver antenna at the repeater rather than at the central station, the multipath problem is eliminated. The directional antennas used can be multiple element beams for the UHF TV system or parabolic dishes for the microwave system.

This method eliminates the need for frequency translators at the repeaters while dictating that all receiver sites use higher-cost, high gain directional antennas. Thus UHF TV remote sites everywhere -- even in the primary coverage area -- need to pay about 50 dollars for their directional receiver antennas. The microwave receiver antennas are already directional in the unextended system, so extending that system by using repeaters does not affect system costs except to add the cost of the repeaters. Furthermore, one more "ring" of repeaters can be used to extend the radius of the coverage area by another d_{max} , thus yielding a service coverage area that can be approximated by a circle with radius of $3 d_{max}$. There are 10 repeaters in the second ring.

Both systems require repeaters for the return channels when the radius of the service area extends to more than the range of the return transmitters. This range depends on topography, tower heights, and other factors just as the forward channel transmission range does. Our choice of 70 miles as the range of the return transmitters for the UHF system is conservative with respect to the theoretical range of a 10 watt transmitter. The topography of some areas will cause a shorter range to be achieved while in other areas greater ranges could be achieved. Seventy miles is a convenient choice for system

costing, because it is equal to the forward channel range of the UHF TV system. Thus everytime the UHF TV system's radius is incremented by a factor of 70 miles, another ring of forward and return repeaters is needed. Microwave systems will add a ring of forward and return repeaters every 40 miles.

Using repeaters as outlined above, a one ring extended microwave system can cover the same area as an unextended UHF TV system. The cost of extending the microwave system is the cost of the five, two-way repeaters, \$137,250. Figure 5.6 compares the cost/S.C.H. of the microwave system and the unextended UHF TV system both of which are capable of distributing a single PLATO IV system over a circular area with a 70 mile radius. From Figure 5.6, we see that if the system is to have more than 315 receiver sites (schools) then the UHF TV system is more economical, while for systems with less than 315 receiver sites, the extended microwave system is less expensive.

The area of system coverage for the unextended UHF TV and the single ring extended microwave systems is $\pi (70 \text{ miles})^2 = 15,400$ square miles. If we assume that each student will get about 20 minutes of PLATO instruction per six hour day, we arrive at a student duty cycle $D = \frac{1}{20}$. This implies that a system with 4032 terminals can serve 80,000 students. Thus we have 80,000 students in an area of 15,400 square miles for a student population density of 5.2 students/square mile. If the student population density is any smaller than 5.2, we must use an extended UHF TV system or a multiple ring, extended microwave system.

As mentioned previously, extending the UHF system adds \$50 to the receiver site costs and also adds the cost of five repeaters at

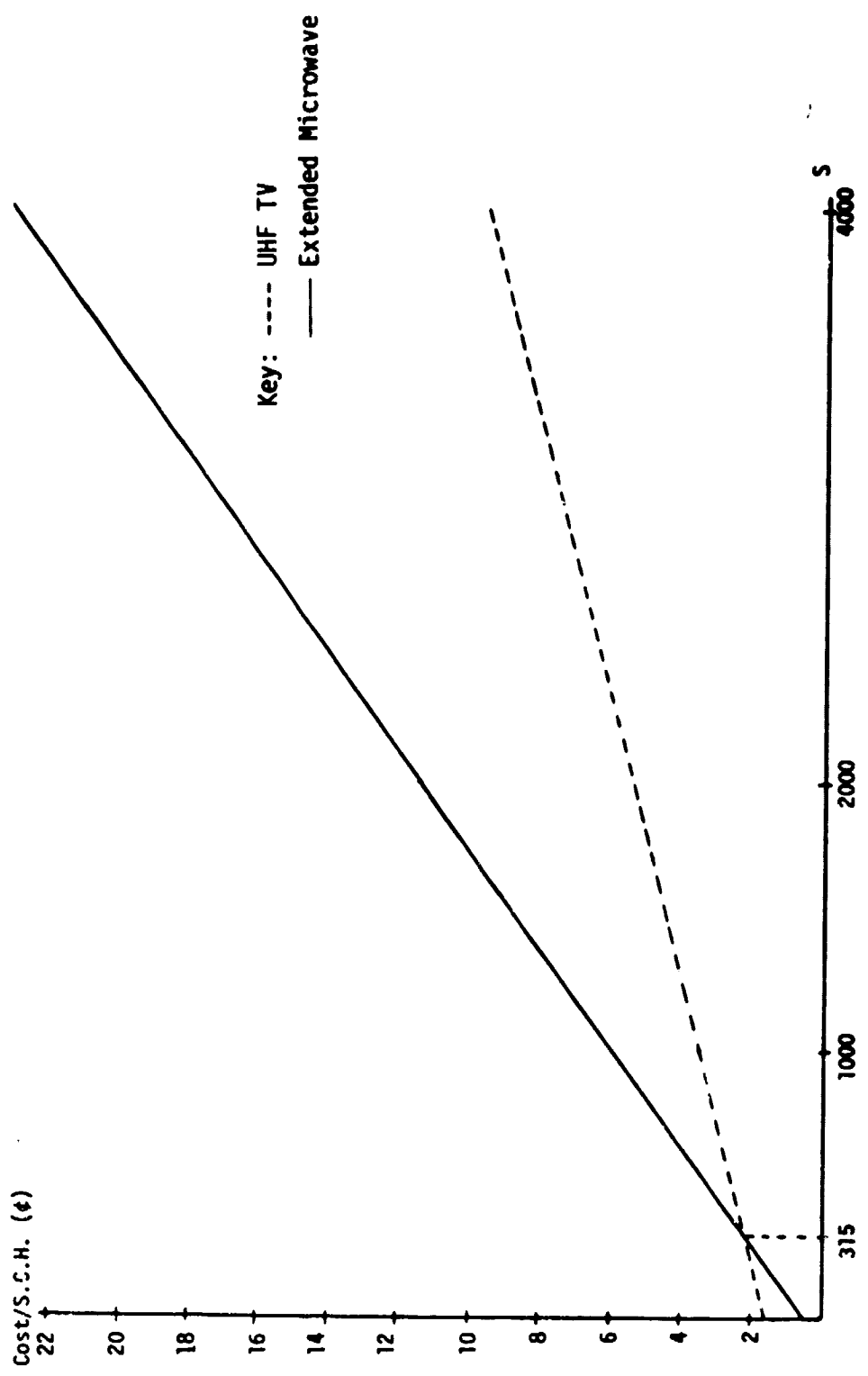

Figure 5.6: Cost of UHF TV and Extended Microwave Systems (Radius=70 miles, L=5)

\$626,000 each. In addition, the return channel needs repeaters. Taking 70 miles as a reasonable limit on the effective transmission path for return data, we deduce that the number of UHF return repeaters is the same as the number of forward repeaters. Recall that the cost of a return repeater is \$1,000.00 when it uses a forward repeater antenna tower.

For a microwave system to cover the same service area as a single ring, extended UHF TV system it will need three rings of two-way repeaters. The three rings of two-way repeaters will have 30 forward repeaters and 30 return repeaters, each pair sharing a common tower. Figure 5.7 compares the costs for the single ring extended UHF TV system and the triple ring extended microwave system, each of which is capable of serving a circular area with radius of 140 miles. By the reasoning used before, this radius corresponds to a student population density of $80,000/\pi (140)^2 = 1.3$ students per square mile. Note that for systems with less than 2,004 remote sites the extended microwave system is cheaper. Thus unless we are to use the terminals in the home, the extended microwave system will be chosen over the extended UHF TV system for sparsely populated areas.

5.5 CONCLUSIONS

In this chapter, we present two UHF radio systems capable of satisfying the communications requirements of the PLATO IV CAI system and compare their costs. We show that communications costs/S.C.H. of between 1¢ to 9¢ can be achieved through implementation of the two systems for serving up to 4,000 remote sites at distances up to 70 miles from the computer center. This corresponds to serving an area with an average student population density of 5.2 students per square mile

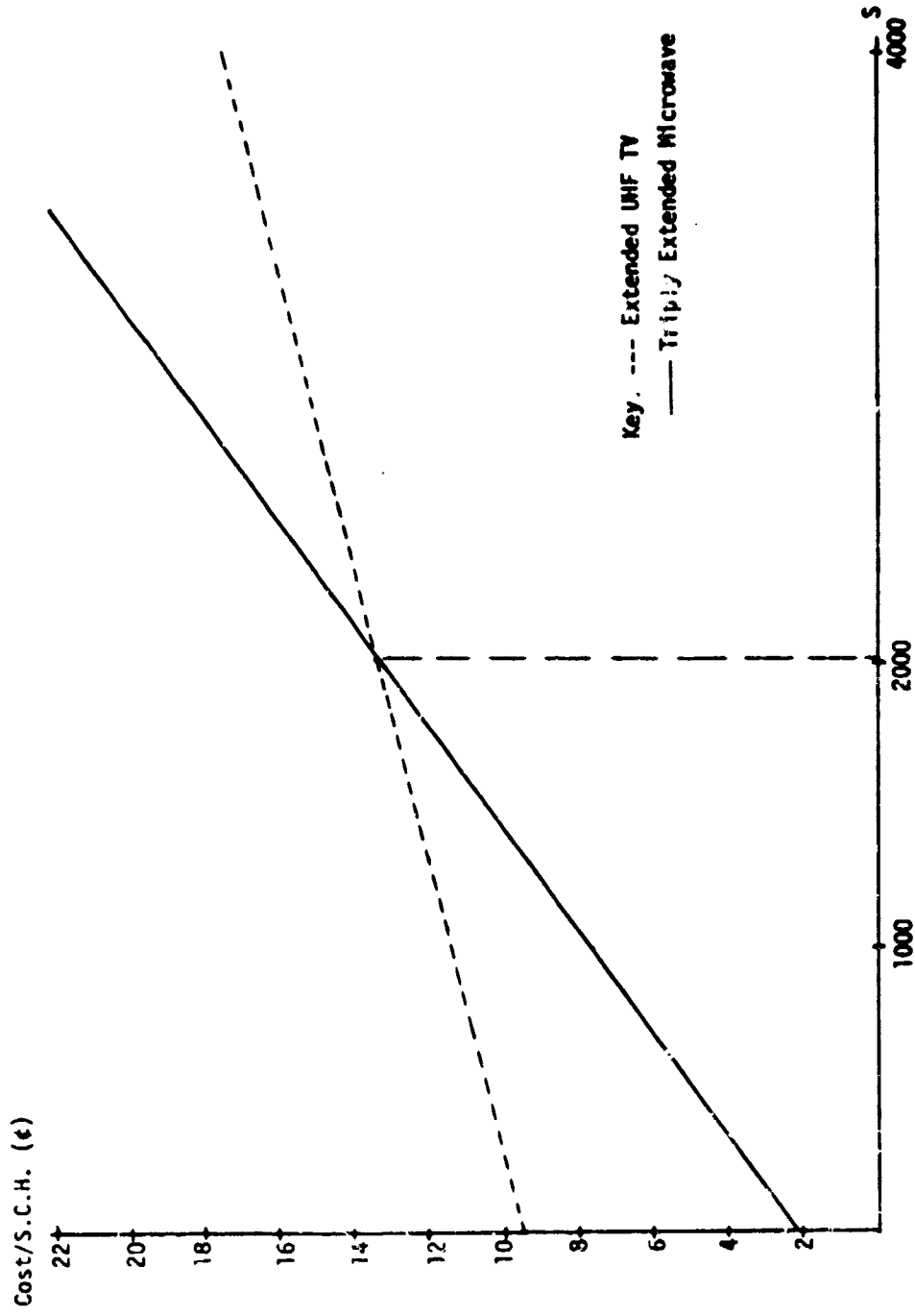

Figure 5.7: Costs of Extended UHF TV and Triply Extended Microwave Systems

or greater. We also shown that, by using repeaters in the forward and return channels, communications costs/S.C.H. of between 2¢ and 17¢ could be achieved while serving up to 4,000 remote users located up to 140 miles from the central computer. This service area represents an average student population density of 1.3 students per square mile or more.

Comparing the costs of the two networks reveals that for student population densities of 5.2 students/square mile or more and for less than 315 schools per PLATO IV system, the single ring extended microwave system is less expensive. In addition, for student population densities of between 1.3 and 5.2 students per square mile, the extended microwave network is the more economical as long as there are fewer than about 2,000 schools per PLATO IV system. Therefore, unless either the topography hampers the use of the microwave system or very large numbers of remote sites must be connected (such as in home use of terminals) the microwave system is preferable.

In computing communications costs for the UHF TV and microwave systems in this chapter, the costs of PLATO IV communications equipment (NIU's and Site Controllers) was not included. Total communications systems costs are computed in the following chapter.

6. COMPARISON OF PHONE, SATELLITE AND RADIO SYSTEMS

6.1 INTRODUCTION: METHOD OF COMPARISON

In the previous three chapters we have described how PLATO IV's communication needs can be satisfied by phone lines, satellites and radio. This chapter compares the three technologies for delivering PLATO IV and gives a guide for choosing the most economical system to be used in a given situation.

Previous chapters calculated communications costs of each of the three types of distribution systems proposed as functions of the number of remote sites or the average distance from the remote sites to the central computer. In order to compare the three systems, this chapter develops costs/S.C.H. curves as a function of student population density (SPD). We chose SPD because real SPD's can be calculated from census data for each state in the United States; thus, our curves allow us to say where in the U.S. each technology is cost optimum.

SPD can affect the cost of a PLATO IV communications system by varying the number of schools (and thus the number of, say, satellite ground stations or radio transceivers) or varying the average distance from school to central computer (causing greater phone line charges and extending radio systems). Therefore, it is necessary to determine how each of these factors is affected by varying SPD to permit calculation of costs versus SPD from costs computed in previous chapters.

In the hopes of obtaining a relationship between SPD and number of schools per PLATO IV system, we manually performed a linear regression on state-by-state statistics on average student population density versus average number of students per school. We

found little correlation between these quantities, and therefore, for the purposes of our calculations, decided to set the number of students/school (and thus schools/PLATO IV system) equal to the average over all states. That is to say, we ignored the possible dependence of system cost on SPD due to varying school sizes with varying SPD.

This assumption made, computing the dependence of system cost on SPD due to varying average distance between schools and the central computer with varying SPD is a straightforward process. If it is assumed that schools are distributed uniformly throughout a circular service area with the computer in the center, the average distance between school and computer is computable as a function of the area of system coverage. Moreover, the area of system coverage is directly related to SPD and the number of students/PLATO IV system. Thus relationships for system cost versus SPD can be computed for each of the three systems and costs can be compared against a common baseline of SPD.

Before undertaking these calculations, we modify one assumption made in previous chapters. To obtain results comparable to those in PLATO literature, communication costs computed in previous chapters did not account for the fixed costs of PLATO IV site controllers (SC's). However, in order to make an honest comparison of the three systems' communications costs, these costs must be considered, because they are not the same for all three systems. Because the satellite and radio systems use wideband forward channels each remote site has its own site controller, and thus it is possible to use site controllers inefficiently. The phone system, however, uses narrowband forward

channels with site controllers located at the computer center, and so it can use site controllers to full capacity, one per thirty-two terminals. Therefore, for comparisons made in this chapter, we adjust costs computed previously to reflect PLATO IV site controller and NIU costs.

In addition, one further discrepancy in previously calculated systems costs has to be adjusted to make the cost comparisons valid. The satellite system costs and telephone costs include maintenance and operating costs while the radio systems costs do not. Accordingly, maintenance and operating costs were added to the radio systems' costs at a rate of 20% of system cost per annum, the same rate charged for the satellite system in the STAMP program.

Having compared the communications costs of the three delivery techniques we obtain a guide to the least expensive system for a given SPD.

We support our results by demonstrating that they are virtually independent of extreme variations in the assumptions that were adopted to acquire them.

The last section of this chapter sites a few modifications that could be incorporated into the PLATO IV communication systems to cut costs even further and increase reliability.

6.2 RELATING COMMUNICATION COSTS TO STUDENT POPULATION DENSITY

The previous three chapters describe how communications costs vary with the distribution of users. Phone systems costs are a function of the number of terminals at the schools and distance of the schools to the computer. Satellite systems cost depend mainly on the number

of ground stations (schools). It does not vary significantly with the area of system coverage. UHF and microwave radio systems costs vary with both area of system coverage and with the number of schools.

In order to compare the communications costs of the three types of systems, costs for all of the systems have to be expressed as functions of a set of common parameters. While it would be possible to plot the systems' costs versus both number of remote sites and area of coverage, we decided to make the comparison more direct by expressing all costs as functions of student population density (SPD). SPD is easily computed for a given area from census data.

To transform previously calculated costs to costs as functions of SPD, there are three relationships we must establish:

- 1) the number of schools per PLATO IV system versus SPD.
- 2) the area of system coverage versus SPD.
- 3) the average distance from school to computer versus SPD.

Having determined these relationships we can express all costs in terms of SPD and then compare.

The average number of schools per PLATO IV system can be computed as:

$$\text{Average Number of Schools/PLATO IV System} = \frac{\text{Number of Students/PLATO IV System}}{\text{Average Number of Students/School}} \quad (6.1)$$

where the number of Students per PLATO IV System is $4032 \cdot \frac{1}{D}$, and D = student duty cycle, and average number of students per school is calculated in Table 6.1 (40, 41) for states in the United States. From (6.1) we see that the only possible dependence of number of remote

Table 6.1 Computed Values of Average Number of Students/School and Student Population Density for the U.S. (40,41)

STATE	Number of Schools	Area	Enrollment	Average SPD	Average Number of Students/School
Alabama	1384	51,609	850,157	16.5	614
Alaska	327	586,412	84,901	.145	260
Arizona	757	113,909	460,125	4.04	608
Arkansas	1251	53,104	461,845	8.70	369
California	6968	158,693	4,597,700	29.0	660
Colorado	1177	104,247	567,042	5.44	482
Connecticut	1117	5,009	655,084	131.	586
Delaware	195	2,057	134,731	65.5	691
Florida	1950	58,560	1,515,298	25.9	777
Georgia	1815	58,876	1,148,361	19.5	633
Hawaii	207	6,450	178,564	27.7	836
Idaho	561	83,557	187,590	2.24	334
Illinois	4599	56,400	2,324,516	41.2	505
Indiana	2198	36,291	1,223,747	33.7	557
Iowa	2066	56,290	660,409	11.7	320
Kansas	1782	82,264	549,412	6.68	308
Kentucky	1544	40,395	723,767	17.9	469
Louisiana	1410	48,523	884,469	18.2	627
Maine	896	33,215	241,198	7.26	269
Maryland	1306	10,577	924,257	87.4	708
Massachusetts	2490	8,257	1,147,561	139.	461
Michigan	3905	58,216	2,164,386	37.2	554
Minnesota	1871	84,068	934,032	11.1	500
Mississippi	1059	47,716	593,033	12.4	560
Missouri	2327	69,686	1,078,347	15.5	463
Montana	--	147,138	180,218	1.22	--
Nebraska	2015	77,227	342,875	4.44	170
Nevada	245	110,540	123,694	1.12	505
New Hampshire	468	9,304	157,960	17.0	337

Table 6.1 Computed Values of Average Number of Students/School and Student Population Density for the U.S. (40, 41)
(continued)

STATE	Number of Schools	Area	Enrollment	Average SPD	Average Number of Students/School
New Jersey	2454	7,836	1,532,791	196.	625
New Mexico	625	121,666	279,348	2.30	447
New York	4411	49,576	3,513,432	70.9	796
North Carolina	2025	52,586	1,217,024	23.1	601
North Dakota	825	70,665	153,721	2.17	196
Ohio	4225	41,222	2,423,831	58.8	574
Oklahoma	1937	69,919	642,584	9.20	332
Oregon	1295	96,981	497,603	5.13	384
Pennsylvania	4379	45,333	2,387,367	52.7	545
Rhode Island	383	1,214	186,632	154.	487
S. Carolina	1181	31,055	666,673	5.09	564
S. Dakota	1021	77,047	172,616	2.24	169
Tennessee	1797	42,244	916,862	21.7	510
Texas	5240	267,338	2,728,007	10.2	521
Utah	561	84,916	312,147	3.68	556
Vermont	426	9,609	101,262	10.5	238
Virginia	1788	40,817	1,108,973	27.2	620
Washington	1693	68,192	820,482	12.0	485
W. Virginia	1375	24,181	412,551	17.1	300
Wisconsin	2360	56,154	980,064	17.4	415
Wyoming	<u>397</u>	<u>97,914</u>	<u>86,440</u>	.883	<u>218</u>
Totals	88,288	not computed	46,235,689		23,763
AVERAGES	1765	not computed	not computed		485

sites (schools) per PLATO IV system on SPD is through the dependence of average number of students per school on SPD.

In order to determine a functional relationship between average student population density and average number of students per school, we calculated both quantities for each of the 50 states in the U.S. The computed values and relevant data are given in Table 6.1. Since average student population densities ranged from .145 students/square mile in Alaska to 196 students/square mile in New Jersey, the log of student population densities was used for plotting convenience.

Figure 6.1 is a plot of the 49 data points (insufficient data were given for Montana). The plot shows no strong relationship between the two quantities. Therefore, for the purposes of our work, we use the nationwide average school enrollment in (6.1) to determine the average number of schools per PLATO IV system. The nationwide average enrollment per school is 485.

We can use this result to compute the average number of schools per PLATO IV system by noting that:

$$\begin{aligned} (\text{Avg. Number of Students/School}) \cdot (\text{Avg. Number of Schools/} \\ \text{PLATO IV System}) &= \text{Number of Students/PLATO IV System} \\ &= 4032 \cdot \frac{1}{D} \end{aligned} \quad (6.2)$$

where Avg. is the arithmetic average and D is the student duty cycle. Using the nationwide average number of students per school of 485 and $D = \frac{1}{20}$ in (6.2) yields an average number of schools per PLATO IV system of 165. Having thus set the number of remote sites at 165 per PLATO IV system the only possible dependence of system cost on student population density is through the relationship between area of system coverage and student population density.

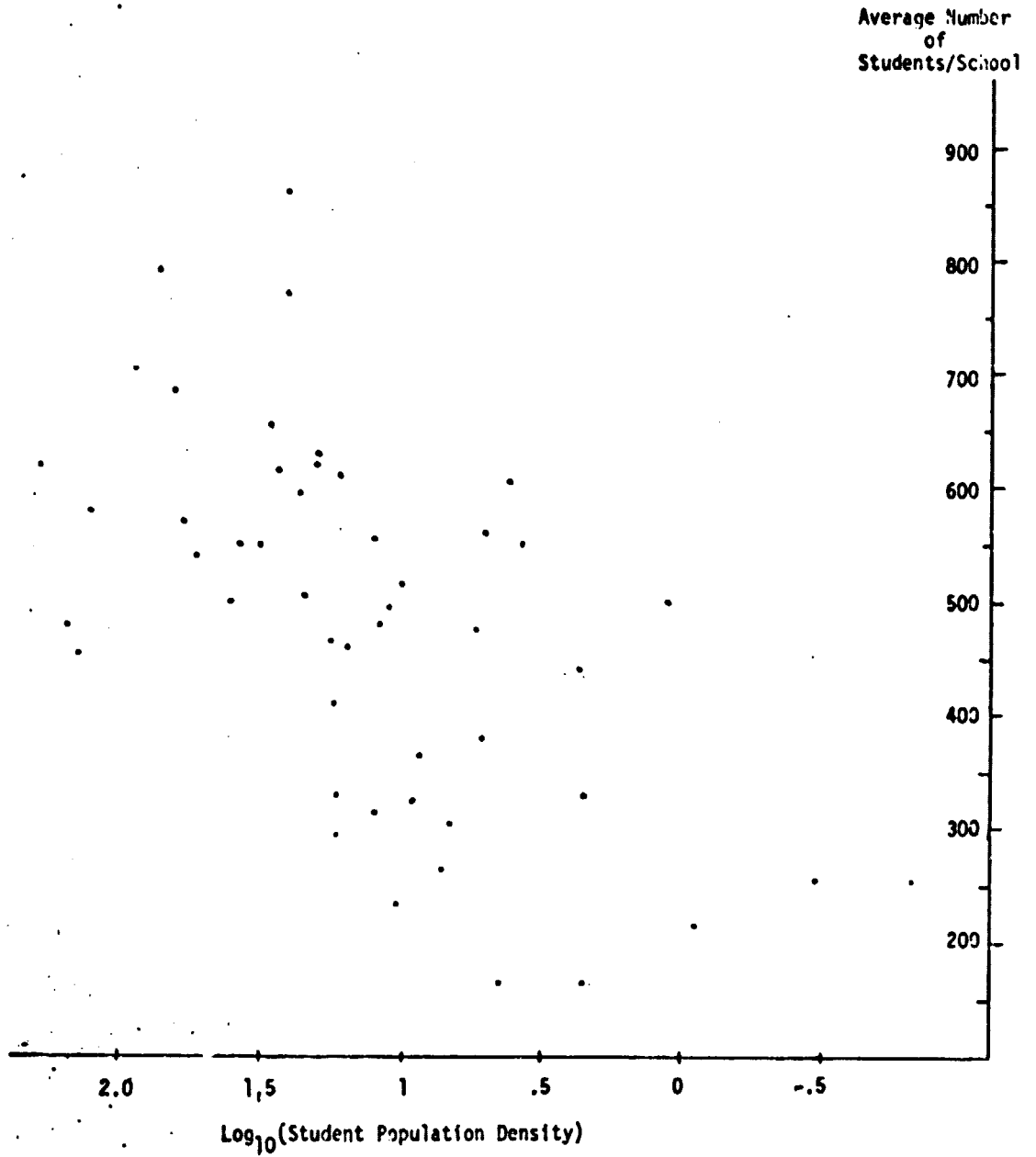

Figure 6.1: Plot of Number of Students/School vs. $\text{Log}(\text{SPD})$

Noting from (6.2) above that each system will serve about 80,000 students when $D = \frac{1}{20}$, and assuming that the system will cover a circular coverage area in which the students live we can deduce a direct relationship between area of system coverage and student population density (SPD) i.e.

$$\text{Area of System} \cdot \text{SPD} = 4032 \cdot \frac{1}{D} = 80,000 \text{ students} \quad (6.3)$$

or

$$R_s = \sqrt{\frac{80,000}{\pi \text{ S.P.D.}}} \quad (6.4)$$

where R_s is the radius of the circular coverage area. Assuming schools are distributed uniformly throughout the circular coverage area, the average distance from school to computer center is $\frac{3}{4} R_s$.

Thus we have a direct relationship between the average distance from school to computer (or radius of system coverage area) and student population density. We have also fixed the number of schools/PLATO IV system at 165 so we are nearly in a position to plot the average communication costs/S.C.H. versus S.P.D. for the three proposed systems for the purpose of comparison. Before comparing these costs we must first adjust them to reflect fairly in all three systems the costs of the PLATO IV communications equipment (the NIU's and SC's) and the cost of operating and maintaining all equipment.

6.3 SYSTEM COMPARISONS

No matter what type of distribution system is used four NIU's will be needed. Differences in PLATO IV communications equipment costs are due to the relative efficiency in the use of site controllers. Because the forward channels in the satellite and radio systems are wideband, each school needs a site controller to separate its data from the 4.8 MB/S stream. Distributing the 4032 PLATO IV terminals

equally to 165 schools implies 24.4 terminals per school. Thus each site controller (S.C.) is used, on the average, at $\frac{24.4}{32} \times 100\%$ efficiency as opposed to site controllers serving users in phone line distributed systems which serve thirty-two terminals and are therefore used 100% efficiently.

Amortization adjustments were necessary in adding NIU and SC costs to the satellite system. In all of our cost calculations except those for the satellite system, equipment is amortized over a five year period; fifteen years are used in satellite system. To adjust for the unequal amortization period between the PLATO IV equipment (5 years) and other satellite system equipment (15 years) the usual costs of 5 year PLATO IV equipment were tripled to account for 3 acquisitions of 5 year equipment over the 15 year satellite system lifetime. The cost differential between satellite and radio systems versus telephone systems due to inefficient S.C. use is $\$9,000 \cdot (165-126) = \$351,000$; about .9¢/S.C.H. Setting the number of schools to 165 and adding the \$30,000 NIU costs, the \$9,000 S.C. costs, and 20% per annum operating and maintenance cost (for the radio system only) to the costs computed in the previous chapters we can use equations (6.2) through (6.4) to plot cost/S.C.H. versus S.P.D. for the three systems. Figure 6.2 displays the results.

From Figure 6.2, we see that the most economical system for population densities from 1.3 students/square mile and up is the microwave MDS. As noted earlier, however, we calculated this microwave system cost by assuming favorable topography in the area to be served. Thus, costs are subject to increases in areas with unfavorable

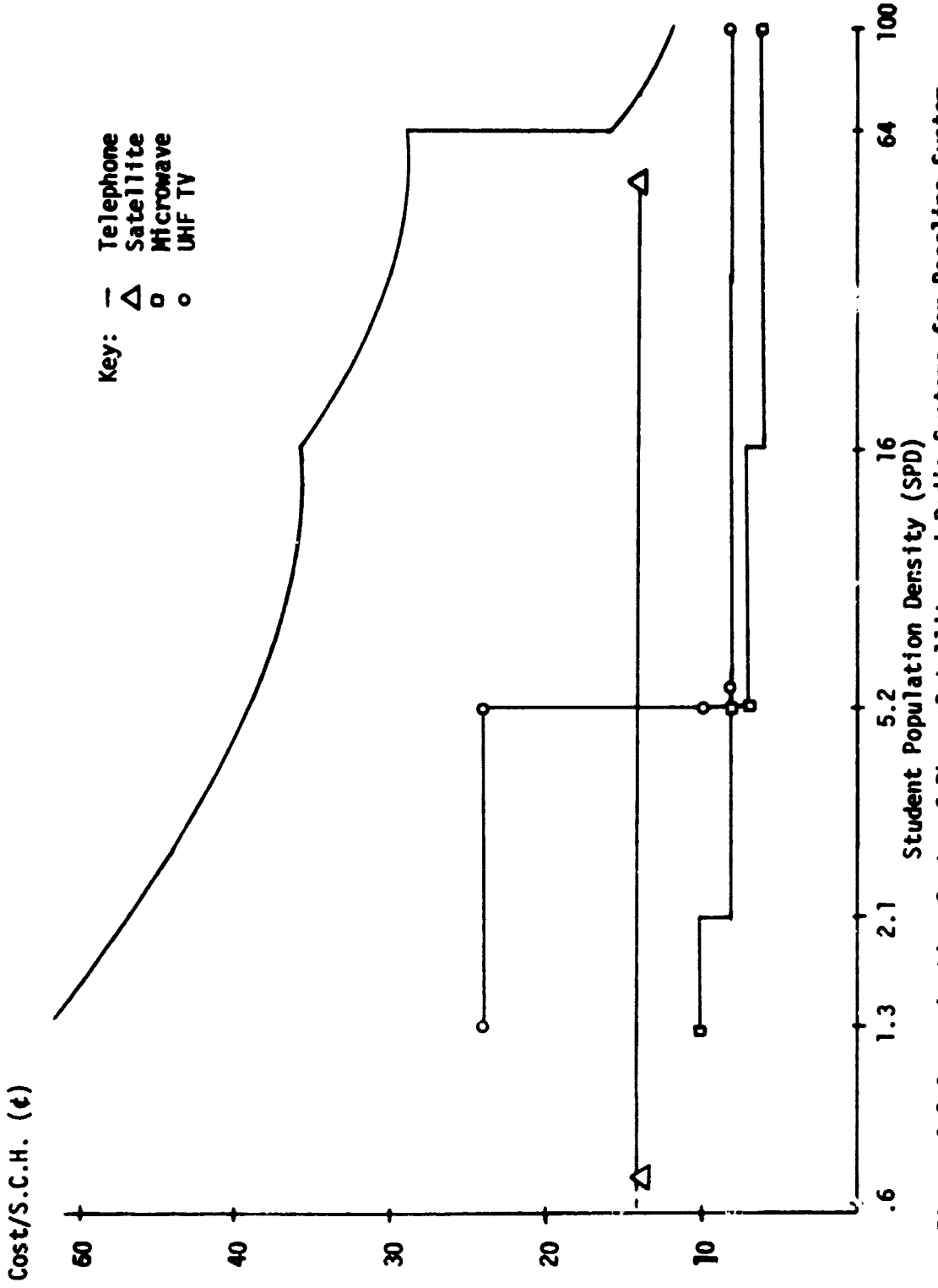

Figure 6.2 Communication Costs of Phone, Satellite and Radio Systems for Baseline System

terrain due to the need for repeaters. Moreover, range limitations preclude serving the most sparsely populated areas by radio. The costs of the phone system level off at an SPD of 160 students/square mile; beyond that point line lengths are less than one mile and charges are assumed constant.

The satellite system attains the 14¢/S.C.H. cost because it is shared by 35 PLATO IV systems. This fact implies cooperation of many diverse cultural, political and geographical communities. Should fewer than 35 PLATO IV systems be distributed by a satellite system of the magnitude described in our study costs would rise significantly. A system with only 17.5 PLATO IV systems sharing the two way satellite described in Chapter 4 would cost 48% more than one with 35 PLATO IV systems or 23¢/S.C.H.

Extending satellite systems coverage to an SPD of .1 student/square mile does not mean that a 14¢/S.C.H. communication cost can be achieved while serving a circular coverage area with a radius of 3,000 miles. Rather it indicates that in the conglomerate of 35 PLATO systems, users in at least one of them can be spread as sparsely as .1 per square mile. As an example a system could serve, among other states, Alaska (SPD = .14).

Even though the telephone system is in general the most expensive system, if PLATO IV CAI is to be introduced into a sparsely populated (SPD < 1.3) area, without cooperation of 35 PLATO IV systems of users (2,822,400 students) needed to warrant a satellite system, the phone system is the only way. Present long-range delivery of PLATO by telephone reflects this fact.

A feel for the relative usefulness of the three systems for distributing PLATO IV CAI to public schools in the United States can be obtained by consulting Figure 6.2 which gives costs relative to SPD and Figure 6.3 which shows the SPD and rural SPD for each state in the United States. Rural SPD has been calculated as described in Chapter 4. Figure 6.2 indicates that either satellite or microwave radio systems are the least costly over the entire range of student population densities to be found in the U.S. Satellite systems are best for densities less than 1.3 students per square mile and microwave systems are best for densities greater than 1.3.

These results reflect the assumptions that were made in deriving them. In particular the number of terminals per site controller plays an important role in affecting system costs. In order to determine in what manner our assumptions affect the relative communications costs we performed a sensitivity analysis, described in the next section.

6.4 SENSITIVITY ANALYSIS

6.4.1 Variation of System Costs with Number of Terminals Per School

Due to the assumptions we adopted in obtaining the comparisons of the three communications networks in the previous section Figure 6.2 expresses costs versus SPD for areas that have the nationwide average number of students per school (485) and thus the nationwide average number of terminals per school (24.4). Table 6.1 demonstrates that the average number of students per school varies over a range from 169 to 796. In adopting the nationwide average of 485 students per school for obtaining the costs presented in Figure 6.2, we found that each school, with its 24.4 terminals, uses its site controller in the radio

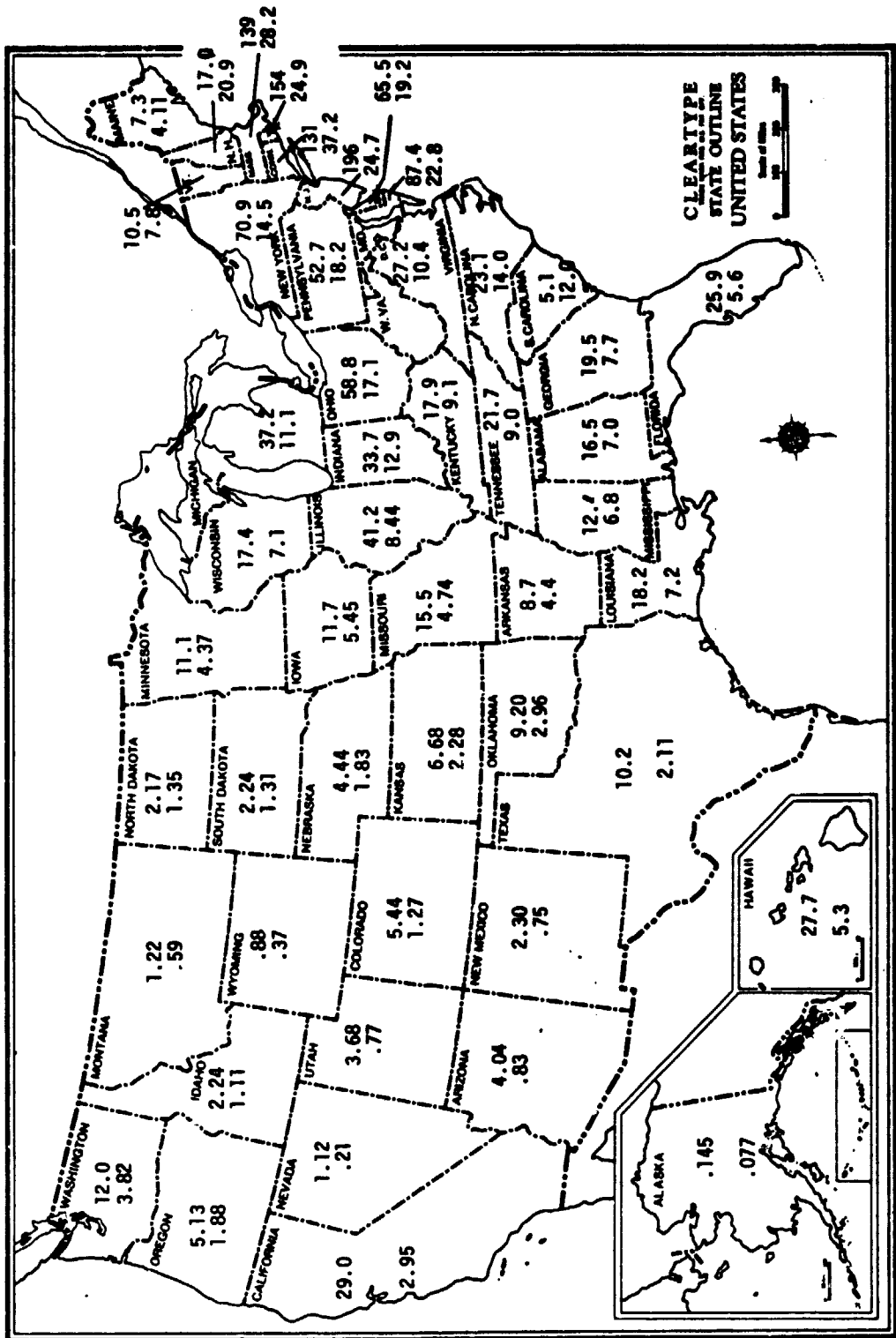

Figure 6.3: Average Student Population Density (SPD) (Upper Entry) and Average Rural SPD (Lower Entry) for States in the U.S.

ORIGINAL PAGE IS OF POOR QUALITY

and satellite systems at 75% efficiency. Even with this relatively inefficient use of site controllers the radio and satellite systems are cheaper than phone systems, which use the S.C.'s at 100% efficiency.

If instead of using the nationwide average number of students per school (485) we use the minimum (169), there would be only eight terminals per school. This causes radio and satellite system's site controller efficiency to drop to only 25%, raising their costs relative to phone systems. Thus telephone systems compare more favorably. Figure 6.4 indicates the costs of the three systems versus SPD when the number of terminals per site is eight.

It is important to note that while we have changed the number of terminals by a factor of three (twenty-four to eight), our earlier conclusions about which delivery system is the least expensive for a given SPD remain relatively unchanged. Comparing Figure 6.4 to Figure 6.2, we see that for an SPD of 64 or more, the phone system replaces microwave MDS. Moreover, for SPD's of between 64 and 5.2, UHF TV is now cheaper than microwave MDS, but radio delivery is still the best. For SPD's of from .1 to 5.2 satellite and microwave systems are still the most economical.

Since Figures 6.2 and 6.4 indicate identical relative comparisons for much of the range of SPD, we can conclude that relative system costs are not especially sensitive to variations in the number of schools per PLATO IV system (alternately the number of terminals per school) assumed in deriving them. Thus our using the nationwide average number of students per school in arriving at 24.4 terminals per school does not restrict our results presented in Figure 6.2.

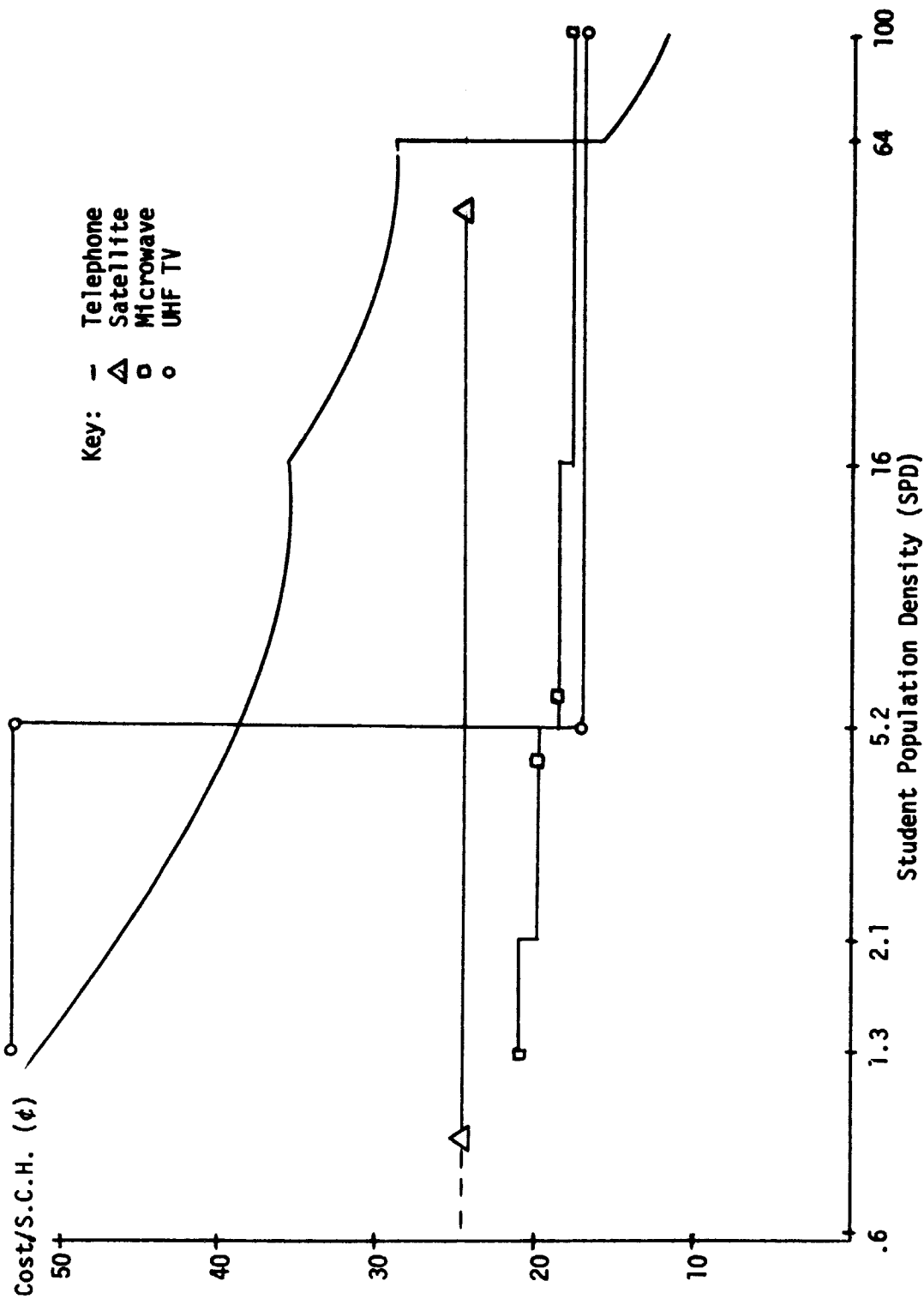

Figure 6.4: Communication Costs for Systems with Only 8 Terminals per School

6.4.2 Variation of Relative Cost Comparisons with Radio Systems' Ranges

The comparisons made in Figure 6.2 can also be affected by variations in the range of coverage of radio systems. If we were to use ranges of twenty miles for microwave and 35 miles for UHF TV instead of forty and seventy miles costs would be given by Figure 6.5. By comparing the baseline system results in Figure 6.2 with those in Figure 6.5, we note that the effect of this variation is to shift the radio portion of the cost curves to the right, consequently increasing the range of SPD over which satellite systems are the least costly from .1 to 4 students per square mile. Otherwise microwave systems are still the least expensive.

Figures 6.4 and 6.5 indicate that the relative comparisons and applicability areas inferred by Figure 6.2 are not extremely sensitive to variations in the two major assumptions adopted in calculating these results. Therefore Figure 6.2 can be used as a guide to the optimal communications network for an area with a given SPD. In particular Figure 6.2, can be used in conjunction with Figure 6.3 to predict areas of applicability of the communications techniques we have studied.

6.5 MODIFICATIONS TO ENHANCE EFFICIENCY

The PLATO IV television data format imposes inefficiencies on its communications networks. For example, Chapter 3 illustrates that an unnecessary stage of encoding-decoding is performed when distributing PLATO via telephone; the NIU's put digital data in the TV format and then the SC's extract the data from this format for transmission over the phone lines. Thus the cost of the digital TV transmitter in the NIU and the cost of the digital TV receiver in the SC can be eliminated

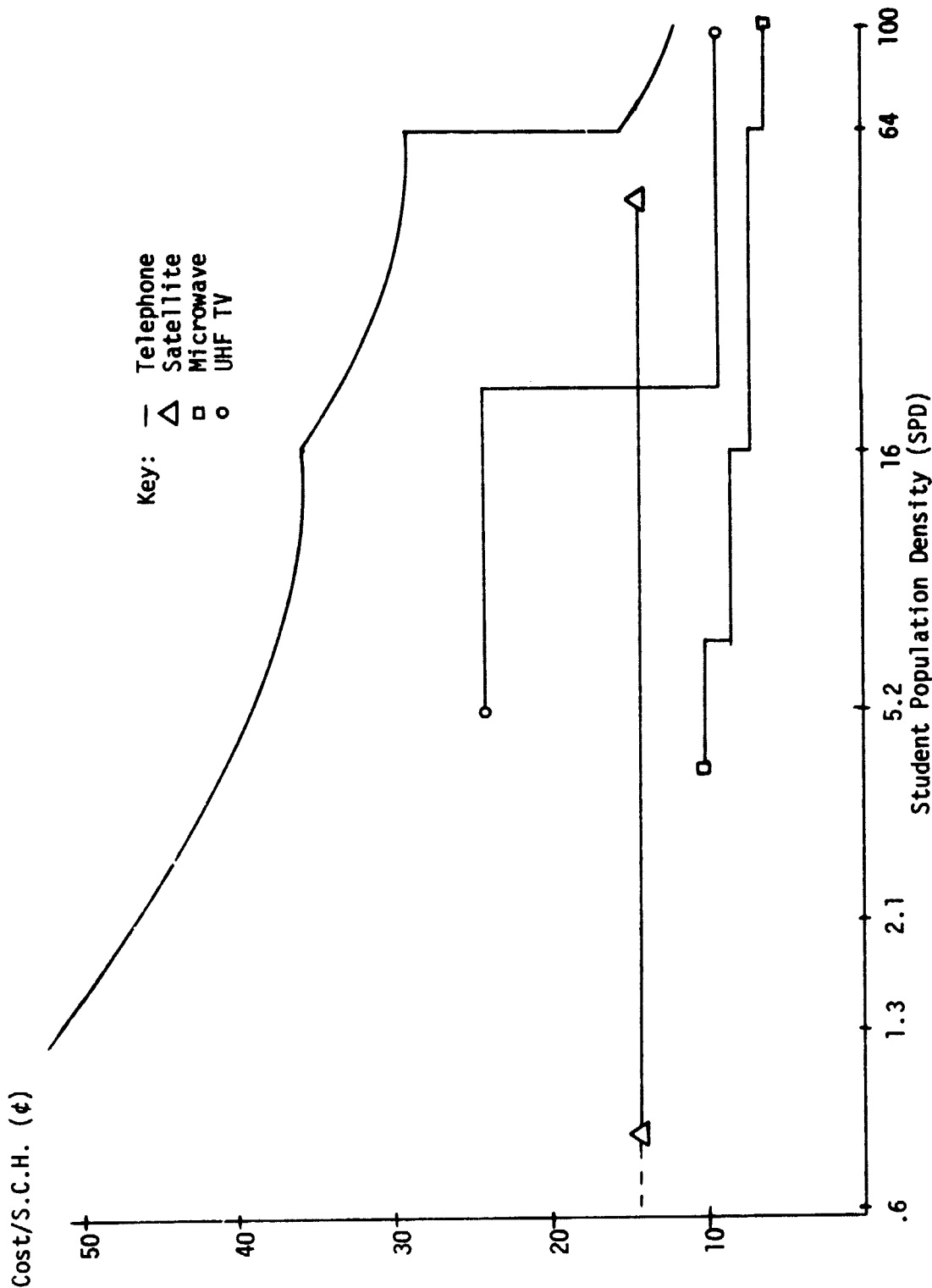

Figure 6.5: Communication Costs when Radio Systems' Ranges are Halved

for systems using telephone distribution. Site Controllers cost \$9,000 apiece or 3.1¢/S.C.H. when used by 32 terminals 160 hours a month for five years. Eliminating roughly 50% of the SC cost by excluding the digital television receiver would save about a penny and a half per student contact hour.

The TV encoding-decoding process, besides being unnecessary is also an inefficient modulation scheme. The synchronization signals used in a TV signal take transmission capacity which could be used for data. Every horizontal scan takes 63.5 microseconds - 10 of which are used for the horizontal sync pulse, and a 1.2 millisecond vertical sync pulse occurs once every 262 horizontal scan lines (16.6 milliseconds). By occupying 23% of the available 6 MHz channel capacity the sync pulses limit channel efficiency to 77%. Therefore, although a TV channel has a 6 MHz bandwidth and can accommodate a 6 MB/S data stream with a one bit per hertz channel encoding efficiency, sync pulses reduce the channel's data capacity to only 4.38 MB/S.

We suggest that, in order to minimize both the delay and the amount of radiated power necessary in satellite distribution systems, the TV format could be replaced by convolutional encoding-Viterbi decoding (42). Convolutional codes are forward error correction codes; many errors can be detected and corrected at the receiver site. Forward error correction is a desirable feature for satellite links, because it greatly reduces the amount of retransmissions (and delays) caused by errors. Moreover, convolutional coding-Viterbi decoding has been shown to operate at the same bit-error-rate as an uncoded technique while using less than half as much power (43). Therefore,

by applying this coding technique to the satellite systems described in Chapter 4, the system could use either smaller antennas or lower power transmitters to achieve a cost reduction. This cost reduction could be greater than the cost of the encoder/decoders (43).

The TV format should most likely be retained for UHF TV distribution of PLATO IV because it allows low-cost, conventional receivers to be used. However, the TV format is unnecessary for the microwave MDS distribution systems, since data could modulate the microwave transmitter in an uncoded format and thus eliminate the need for decoding the data from the TV format at the receiver sites as is presently performed by the SC. As in the modified telephone distribution system a substantial portion of the NIU and SC costs could be eliminated, decreasing cost/S.C.H.

7. CONCLUSIONS

This thesis presents the results of a study of communications network designs and costs for the dissemination of PLATO IV CAI data. It describes the communications requirements of PLATO IV, demonstrates how these requirements can be satisfied by several different networks, and computes costs for each network. It presents costs per student contact hour (S.C.H.) to be consistent with the terminology used by other researchers in the field.

The networks studied used leased telephone lines, satellite, or microwave or UHF radio to deliver PLATO IV CAI. The work has specified the conditions under which each of these networks is cost optimum. In addition, it has applied these results to design networks for PLATO IV distribution to primary and secondary public schools in the United States. By computing communication costs as functions of student population density (SPD) for each network, and by presenting a map of the U.S. that gives the rural and average SPD of each state, the thesis has provided a guideline for deciding which of the systems is most cost effective for a given geographical area.

The networks designed in this thesis achieve communication costs per S.C.H. well under the 25-30¢/S.C.H. total cost goal of PLATO IV designers. This fact suggests that the networks presented would be viable if they were implemented. It also points out the usefulness of a study of this type, since present PLATO communication methods often cost many times more than this total cost goal.

The work shows that microwave radio broadcast systems are the least expensive for SPD's of 1.3 students per square mile and higher,

when there are twenty-four terminals located at each receiver site. The costs of these microwave networks range from 6¢/S.C.H. to 10¢/S.C.H. Despite their attractive costs, however, microwave systems are limited in a number of ways. The microwave system can only serve areas with average student population densities above 1.3, because the range is limited by the curved earth. Moreover, repeaters may be needed to provide service to users who are located in valleys or behind obstructions and are unable to receive reliable data from either the central transmitter or from one of the range extending repeaters. Therefore, employing microwave data distribution in hilly areas costs more than our results predict. This thesis provides enough information to estimate fill-in repeater costs for a given region. In addition, another difficulty in implementing this delivery scheme might be in obtaining new FCC allocations for the return data channels required.

Like the microwave system, UHF TV data broadcast systems are range-limited. Because the UHF systems use higher-powered transmitters and lower frequencies, they enjoy a range nearly double that of microwave systems, and they are less sensitive to obstructions. UHF systems are characterized by good range (seventy miles without repeaters), expensive transmitter stations and inexpensive receivers. For ranges up to seventy miles (SPD's greater than 5.2) UHF TV systems with twenty-four terminals per school cost 8¢/S.C.H. - within 2¢/S.C.H. of the microwave systems. Extending a UHF TV system (for ranges greater than seventy miles) raises its cost to 24¢/S.C.H., higher than both microwave and satellite systems. Since the UHF TV systems are less sensitive than microwave systems to terrain variations and cost only a penny or two more per S.C.H. than microwave systems with

no fill-in repeaters, for SPD's greater than 5.2, they should be considered as alternatives to microwave systems for hilly areas with SPD's in this range. However, the UHF TV systems also might need new FCC allocations for return channels.

Satellite systems achieve a 14¢/S.C.H. cost for networks with twenty-four terminals per school in sparsely populated areas. This cost calculation assumes that a large (2.7 million students) user group in states with rural student population densities from .21 to 3.82 students per square mile shares the satellite costs. Many institutions would have to cooperate to form such a large group; this is the most significant obstacle to the implementation of a low-cost satellite distribution network. The intrinsic propagation delay of satellite links might require a redesign of the student terminal to retain the rapid CAI interaction of the present PLATO IV system.

Phone systems do not offer the minimum cost of the systems in question for any range of SPD when there are twenty-four terminals per school. However, there are two cases when the use of leased phone lines is justified. When SPD is less than 1.3 students per square mile, and a large satellite user group can not be mustered, telephone systems are the only alternative, though they cost over 50¢/S.C.H. Moreover, when there eight terminals per remote site, phone lines are best for ranges less than fifteen miles, and in this case they offer costs less than 15¢/S.C.H. If even fewer terminals per remote site are to be used, the range for cost-optimum use of the telephone system increases.

In order to test the sensitivity of our results to the assumptions adopted in deriving them, a sensitivity analysis was performed. This

analysis demonstrated that, although the absolute costs of the various communication techniques varied with fluctuations in our assumptions, the relations between costs remained fairly consistent. Therefore the guideline developed in this thesis under the assumption of a homogeneous user distribution can be used to find the least expensive communication network for distributing CAI to public schools in areas with inhomogeneous user distributions.

We also noted that the currently used PLATO IV TV-data format is inefficient for telephone, satellite and microwave radio systems. Consequently we suggest that it be replaced by a more efficient time division multiplexing scheme. However, because the TV format allows the use of inexpensive commercial television receivers at remote sites in UHF TV broadcast systems, it should be retained in these systems when a relatively large number of terminals exist at each site to share the site controller cost. Those systems that dispense with the TV-data format will enjoy a cost savings by eliminating the TV encoding and decoding equipment. For the satellite systems, the TV-data format might cost effectively be replaced by convolutional encoding-Viterbi decoding. This technique allows for the use of lower powered transmitters or smaller antennas to offer a cost savings.

8. BIBLIOGRAPHY

1. Alpert, D. and Bitzer, D., "Advances in Computer-Based Education: A Progress Report on the PLATO System," CERL Report X-10, Computer-Based Education Research Laboratory, University of Illinois), (July 1969).
2. Bitzer, D. and Skaperdas, D., "The Design of an Economically Viable Large-Scale Computer-Based Education System," CERL Report X-5, (Computer-Based Education Research Laboratory, University of Illinois), (July 1973).
3. Kopstein, Felix F., et. al., "Computer-Administered Instruction Versus Traditionally Administered Instruction: Economics," Audio Visual Communication Review, Vol. 16, No. 2, (Summer 1968).
4. Simonsen, R. H. and Renshaw, K. S., "CAI-Boon or Boondoggle?," Datamation, Vol. 20, No. 3, (March 1974).
5. Simonsen, R. H., "Computer Assisted Instruction," The Boeing Company, (August 1969).
6. Stifle, J., Information Acquired During Visit to the PLATO IV Computer-Based Education Laboratory by Author, (September 1974).
7. Stifle, J., "The PLATO IV Architecture," CERL Report X-20, CERL, University of Illinois, (May 1972).
8. Stifle, J.; Bitzer, D.; and Johnson, M., "Digital Data Transmission Via CATV," CERL Report X-26, CERL University of Illinois, (June 1971).
9. "Analysis of Some Queueing Models in Real Time Systems," IBM Corporation, (1971).
10. Telephone Conversations With R. Roehr and T. Mayer of the South-Western Bell Telephone Company's Marketing and Engineering Staff, (August 1974).
11. "Codex 8200 Local Distribution Service Unit," Specification Sheet, Codex Corporation, (Effective September 1974).
12. "Modem-Multiplexor Survey," Computer Decisions, Staff Report, (October 1973).
13. Codex Corporation Price Sheet AH2 D 2M-8-74, (Effective September 1, 1974).
14. Personal Conversations With Ron Hendricks of the Codex Corporation's St. Louis Office, (October 1974).

15. Bergin, Patrick, et. al., "Information Transfer Satellite Concept Study--Final Report," in four volumes, NASA Contractor Report No. CR-114312, Convair Aerospace Division of the General Dynamics Corporation, San Diego, California, (May 1971).
16. Stagl, T., et. al., "Computer-Aided Communication Satellite System Analysis and Optimization," Report No. R(T)-73/2, Center for Development Technology, Washington University, St. Louis, Missouri, (October 1973).
17. Telephone Conversation With Al Koury of Hughes Aircraft Corporation's Marketing Division, El Segundo, California, (August 1974).
18. Price List A-5, MCL Corporation, La Grange, Illinois, (Effective July 9, 1974).
19. Prodelin Corporation Antenna Data Sheet, (Effective June 1974).
20. Telephone Conversation With J. Salmanson of NASA, (August 1974).
21. Jamison, D., et. al., "Communication Economics of Interactive Instruction for Rural Areas: Satellite Versus Commercial Telephone Systems," Stanford University, Stanford, California.
22. Morley, R. and Eastwood, L., "Distribution of PLATO IV CAI Over Leased Telephone Lines," Internal Memorandum, Center for Development Technology--Communications Group, Washington University, St. Louis, Missouri, (November 1974).
23. Perrine, J. R., "Telecommunications Technology and Rural Education in the United States," Center for Development Technology, Report No. CDTCG-R(T)-75/1, Washington University, St. Louis, Missouri, (March 1975).
24. Census of the United States, (1970).
25. "Statistics of Public Schools, Fall 1971," U.S. Department of Health, Education and Welfare, Office of Education.
26. Risch, C., et. al., "Design of a 12 Channel FM Microwave Receiver," Report No. R(T)-7412, Center for Development Technology, Washington University, St. Louis, Missouri, (July 1974).
27. Feiner, Al, "Health Care and Education: On the Threshold of Space," Science, pp. 1178-1186, (December 27, 1974).
28. Schwartz, M., "Information Transmission, Modulation, and Noise," McGraw-Hill, (1970).
29. Morley, R., "Status Report On Radio-Data Communications at the University of Hawaii's ALOHA System," Internal Memorandum, Center for Development Technology, Washington University, St. Louis, Missouri, (February 1975).

30. Telephone Conversation With Mr. Jack Stifle of the PLATO IV Engineering Staff, (October 1974).
31. Price Quote from Mr. Phillip Warner of Microband National System, Incorporated, (November 21, 1974).
32. "Reference Data for Radio Engineers," ITT Corporation, Fourth Edition, (March 1957).
33. "2150 MHz Multipoint Distribution Service Systems," Varian Micro-Link, Beverly, Massachusetts, (1974).
34. Telephone Conversation With Members of RCA's St. Louis Marketing Office, (December 1974).
35. Price of Sears Roebuck Company's Nine-Inch Black-and-White UHF/VHF Television, (March 1975).
36. Price Obtained from the Tuner Service Corporation, Bloomington, Indiana, (March 1975).
37. Northrup, G. M., "Aids for the Gross Design of Satellite Communication Systems," IEEE Transactions on Communication Technology, (February 1966), pp. 46-56.
38. Telephone Conversation With Mr. David Wax of the University of Hawaii's ALOHA System Engineering Staff, (February 1975).
39. "RCA UHF TV Transmitting Equipment Catalog," RCA Broadcast and Communications Products Division, Camden, New Jersey, (1966).
40. "Digest of Educational Statistics," National Center for Educational Statistics, Office of Education, (1973).
41. "Statistical Abstract of the U.S.," U.S. Department of Commerce, (July 1974).
42. Viterbi, A. J., "Convolutional Codes and Their Performance in Communication Systems," IEEE Transactions on Communications Technology, Vol. 19, No. 5, (October 1971).
43. "Coding Investigation of Time Division Multiple Access Communications," Linkabit Corporation Technical Report RADC-TR-73-140, (July 1973).