

General Disclaimer

One or more of the Following Statements may affect this Document

- This document has been reproduced from the best copy furnished by the organizational source. It is being released in the interest of making available as much information as possible.
- This document may contain data, which exceeds the sheet parameters. It was furnished in this condition by the organizational source and is the best copy available.
- This document may contain tone-on-tone or color graphs, charts and/or pictures, which have been reproduced in black and white.
- This document is paginated as submitted by the original source.
- Portions of this document are not fully legible due to the historical nature of some of the material. However, it is the best reproduction available from the original submission.

X-953-75-186

PREPRINT

NASA TM X-70952

L-BAND, 1.2m PARABOLIC ANTENNA-NOISE TEMPERATURE MEASUREMENT

RALPH E. TAYLOR
JAMES S. HILL

(NASA-TM-X-70952) L-BAND, 1.2 m PARABOLIC
ANTENNA-NOISE TEMPERATURE MEASUREMENT (NASA)
7 p HC \$3.25 CSCL 17B

N75-30391

Unclas
G3/32 34746

JULY 1975



GUDDARD SPACE FLIGHT CENTER
GREENBELT, MARYLAND

Prepared for presentation at International Telemetering Conference,
ITC/USA/'75, October 14, 15 & 16, 1975.
(Washington, D. C.)

L-BAND, 1.2 m PARABOLIC ANTENNA - NOISE TEMPERATURE MEASUREMENT

By RALPH E. TAYLOR and JAMES S. HILL

Summary. - Extensive antenna-noise temperature measurements at 1.6 GHz (L-Band) were made using a 1.2 m (4 ft. diameter) parabolic dish antenna mounted on the Flying Bridge of a modern 15,690-ton, commercial-container ship owned by the United States Lines. Both in-harbor and at-sea radiometer measurements were made that indicated a steady background, antenna-noise temperature value slightly less than 70 degrees kelvin (K) at elevation angles of 5°, and greater, at 1.6 GHz. A comparison of theoretical and measured values indicate excellent agreement within about 5K for at-sea data.

These measurements should be especially helpful to RF equipment designers of maritime, L-Band shipboard terminals for operation with the two, geostationary, maritime satellites, Marisat-A and -B.

Introduction. - The United States Lines 15,690-ton, commercial-container ship, "American Alliance," was selected for the installation of an experimental, L-Band, Shipboard Terminal using a 1.2 m-diameter (4 ft.), parabolic dish antenna for reception of satellite signals at 1.6 GHz [1, 2].

Antenna-noise temperature measurements were made at 1.6 GHz, from June 16-20, 1974, onboard the "American Alliance," while berthed at Port Elizabeth, New Jersey (USA), and at sea while enroute from Port Elizabeth to intermediate ports along the Eastern Coast of the United States to as far south as Savannah, Georgia. While at sea, the ship maintained a minimum of 20 miles distance from the shoreline to minimize line-of-sight interference from the shore.

Shipboard Installation. - Various subsystems of an operational L-Band Shipboard Terminal provided essential equipment including a 1.2-m-dia. paraboloidal (dish) reflector, without radome, with 24 dB gain above isotropic at 1.6 GHz. Receiver subsystems resulted in a system noise figure of 5.9 dB. The 1.2 m antenna contained a right-hand circularly polarized, prime-focus, RF feed for 1535 - 1660 MHz operation.

A make-shift antenna stand, and tripod mount with azimuth-elevation swivel axes, were used to position the dish antenna centerline approximately 2.8 m above the deck of the Flying Bridge for antenna mainlobe clearance (Fig. 1). The above-deck configuration for the vessel, "American Alliance" is given in Fig. 2. The antenna stand was positioned on the starboard side of the ship's "Flying Bridge", in the approximate location selected tentatively for an operational L-Band Shipboard Terminal. A 12-m-length, low-loss coaxial cable ran from the output terminal of the 1.2 m dish antenna to a radiometer located in the ship's Wheelhouse immediately below the "Flying Bridge."

Antenna-Noise Temperature Measurements. - With the 1.2 m antenna positioned on the Flying Bridge (Fig. 1), antenna-noise temperature at a center frequency of 1.6 GHz was measured using an Airborne Instruments Laboratory Type 2392B

Mr. Taylor is with National Aeronautics and Space Administration, Goddard Space Flight Center, Greenbelt, Md.

Mr. Hill is with RCA Service Company, Springfield, Va.



Fig. 1. 1.2 m dish antenna tripod and stand on Flying Bridge

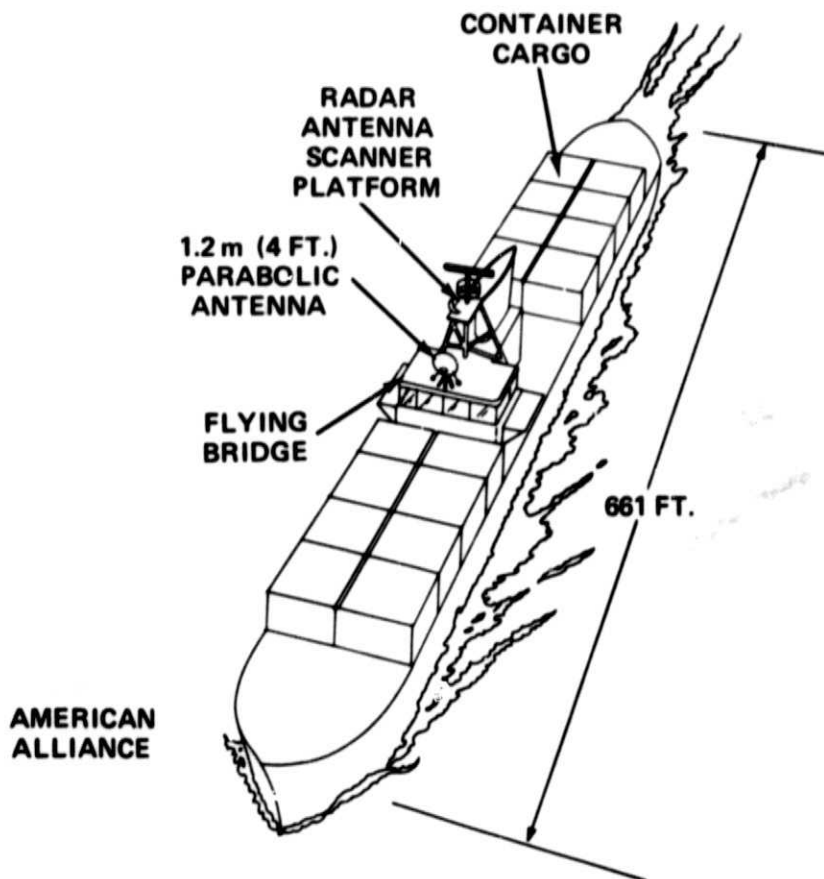

Fig. 2. Above-deck configuration of vessel, "American Alliance."

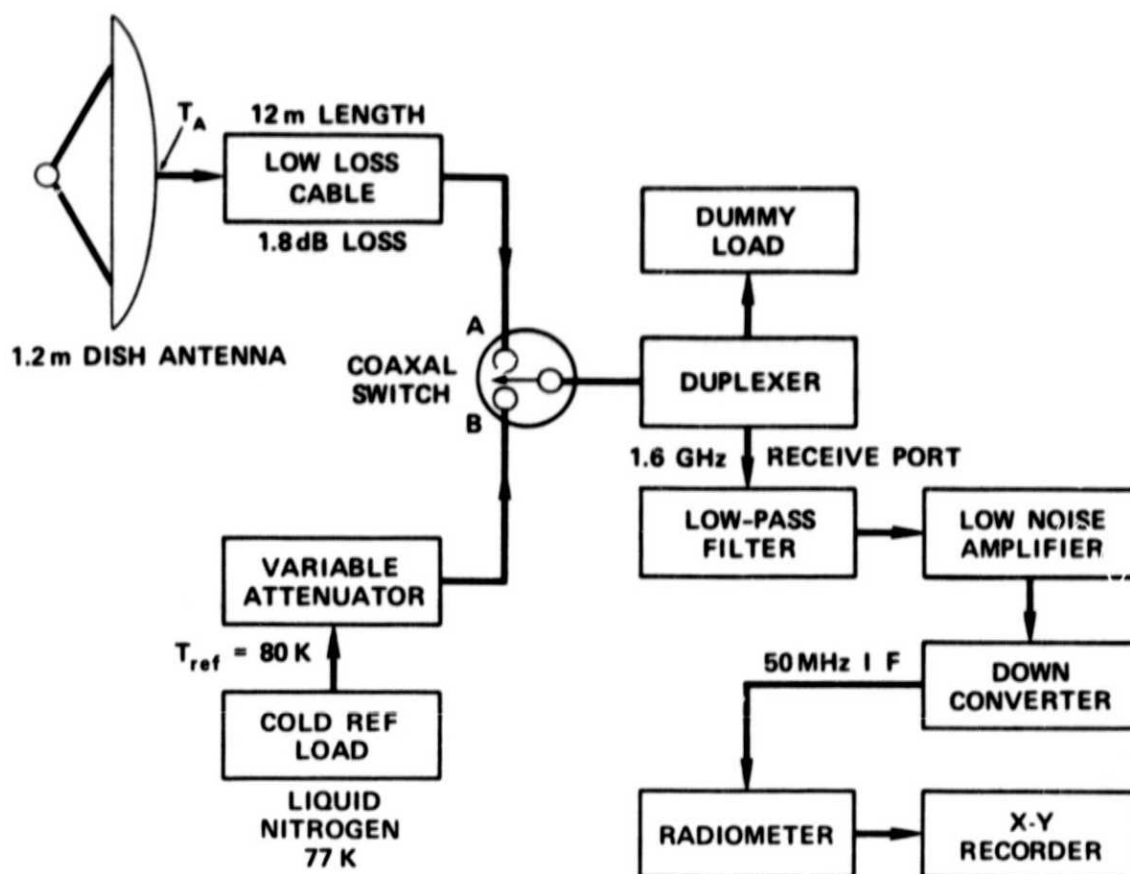

Fig. 3. Radiometer for antenna-noise temperature measurements.

Radiometer [3], and cold-load reference temperature (liquid nitrogen, 77 K) located in the Wheelhouse (Fig. 3). A continuously-variable precision attenuator (ARRA* Type 5614-60 L) was adjusted to obtain an equal output reading on the X-Y Recorder for both switch positions A and B. Measurements were made then for the 1.2 m antenna azimuth angles from 0° - 360° , in 20° increments, and for elevation angles from 0° - 90° , in 5° and 10° increments.

Since an apparent antenna-noise temperature was measured at the output end of the 12 m coaxial cable (switch terminal A, Fig. 3), it was necessary to compute antenna-noise temperature T_A , referenced to the 1.2 m antenna's output terminals, considering the fixed 1.8 dB transmission cable loss. Two methods [4] were necessary: Method 1 was used for computing values of T_A less than, or equal to the cold-load reference temperature, $T_{ref} = 80$ K; Method 2 was used for values of $T_A > T_{ref} = 80$ K. A description of each method follows.

Method 1. - The apparent antenna-noise temperature T'_A , measured at switch terminal A, is expressed as

$$T'_A = T_A \omega + (1 - \omega) T_0 \text{ degs Kelvin (K)} \quad (1)$$

*Calibrated at 1.6 GHz both before and after sea test using calibrated standard signal generator and RF power meter.

for $0 \leq \omega \leq 1$ (dimensionless). Similarly at switch terminal B,

$$T_a = T_{ref} \alpha + (1 - \alpha) T_0 \text{ degs K} \quad (2)$$

for $0 \leq \alpha \leq 1$ (dimensionless) where

- ω = antenna transmission line attenuation power loss
- α = total attenuation (power loss) of variable attenuator, including miscellaneous losses
- T_{ref} = cold-load reference noise temperature = 80 K
- $T_0 = 300 \text{ K}$ = ambient physical temperature of all transmission lines

Setting $T'_A = T_a$ from (1) and (2), and solving for T_A gives,

$$T_A = T_0 + \frac{\alpha}{\omega} (T_{ref} - T_0) \text{ degs K} \quad (3)$$

$\lim (\alpha/\omega) \rightarrow 0, T_A \rightarrow T_0, \text{ max.}$ Furthermore, (3) is used only for computing values of $T_A \leq T_{ref}$, corresponding to lower scale readings on the variable attenuator.

Method 2. - On the other hand for higher scale readings of the variable attenuator, corresponding to values $T_A > T_{ref}$, T'_A at terminal A is expressed in terms of the noise temperature of the attenuation [4] as,

$$T'_A = T_A + (L_\omega - 1) T_0 \text{ degs K} \quad (4)$$

for $1 \leq L_\omega < \infty$. Similarly at terminal B,

$$T_a = T_{ref} + (L_a - 1) T_0 \text{ degs K} \quad (5)$$

for $1 \leq L_a < \infty$ where

- L_ω = antenna transmission line loss power ratio
- L_a = total attenuation power loss ratio for cold-load reference arm

Again setting $T'_A = T_a$ in (4) and (5), gives a value of T_A as,

$$T_A = T_{ref} + T_0 [L_a - L_\omega] \text{ degs K} \quad (6)$$

Note that when $L_a = L_\omega, T_A = T_{ref}$. Whereas Method 1 is used only for values of $T_A \leq T_{ref}$, Method 2 is used only for values of $T_A > T_{ref}$.

Test Results. - Antenna-noise temperature measurements at 1.6 GHz were made both at sea and in the harbor (Figs. 4, 5); in general, antenna-noise temperatures were lower at sea. This is especially true of "hot spot"* noise temperatures resulting from harbor-generated EMI (e.g., loading cranes, dock rotating machinery, etc.). Also, a series of "hot spots" were identified as 1.6 GHz signals from the NASA Applications Technology Satellite (ATS-6), in geostationary orbit at 94 W. longitude (Fig. 4).

*Noise temperature greater than steady background noise temperature.

The majority of the "hot spot" noise temperatures, above 5° elevation angle, disappeared as the "American Alliance" went to sea (Fig. 5). Exceptions are the two "hot spot" noise temperatures resulting when the 1.2 m antenna mainlobe pointed toward the radar-scanner platform on the mast (65° elevation angle, Figs. 4 and 5, and when the Sun entered the mainlobe at 75° elevation angle (Fig. 5).

In general, the measured steady background noise temperature increased sharply below 5° elevation angle (Figs. 4, 5). However, at angles greater than 10°, the steady component remains fairly constant vs. elevation angle from 10° - 85°. The average background noise temperature varies, within this range of angles, from 50 K to 60 K, at sea; and from 65 K to 75 K, in harbor. Each data point (dot), in general, represents 18 independent measurements, obtained at azimuth angles from 0° - 360°, in 20° increments. Antenna-noise temperatures not averaged include all "hot spot" noise temperatures identified by circled X's.

Blake [5] gives theoretical values of T_A for a ground-based antenna, at 1.6 GHz, as given in Table 1. A ground-based antenna within a few hundred feet of the earth's surface is assumed. Steady background noise temperature data points from Figs. 4 and 5 indicate close agreement, except at 0° elevation angle.

Table 1

Comparison of theoretical vs. measured antenna-noise temperature at 1.6 GHz

Elevation Angle	Antenna-Noise Temperature (degs K)		
	Blake's [6] Theoretical Value	In-Harbor Data (Fig. 4)	At-Sea Data (Fig. 5)
0°	125 K	150 K	96 K
5°	70 K	68 K	68 K
10°	62 K	64 K	56 K
90°	55 K	65 K*	55 K*

*Actually @ 85° elevation angle.

Since the antenna-noise temperature (Table 1) is only 70 K, or less, for elevation angles of 5°, and greater, it is worthwhile for RF equipment designers to strive for improving receiving system noise temperature. For example, modern low-noise bipolar transistor amplifiers have noise figures as low as 2.0 dB at 1.6 GHz. Assuming $T_A = 70$ K and 1.0 dB transmission loss between the antenna output terminals and the preamplifier input terminals, gives a receiving system noise temperature of only 300 K — a significant improvement of 5 dB in received carrier-to-noise spectral density ratio compared to 950 K (noise figure = 5.9 dB).

The component parts of Blakes' [6] theoretical value of antenna-noise temperature $T_A = 70$ K, for 5° elevation angle at 1.6 GHz, indicate contributions of 9 K for average cosmic noise, 10 K for quiet-sun noise in the antenna's sidelobes, 18 K for tropospheric (atmosphere) noise, leaving a remaining estimated 33 K average antenna sidelobe noise from the ship's structure. This is roughly equivalent to a ground-based, directive antenna.

A comparison of theoretical and measured values for T_A , in Table 1, for at-sea data at elevation angles of 5°, and above, indicate agreement within about 5 K.

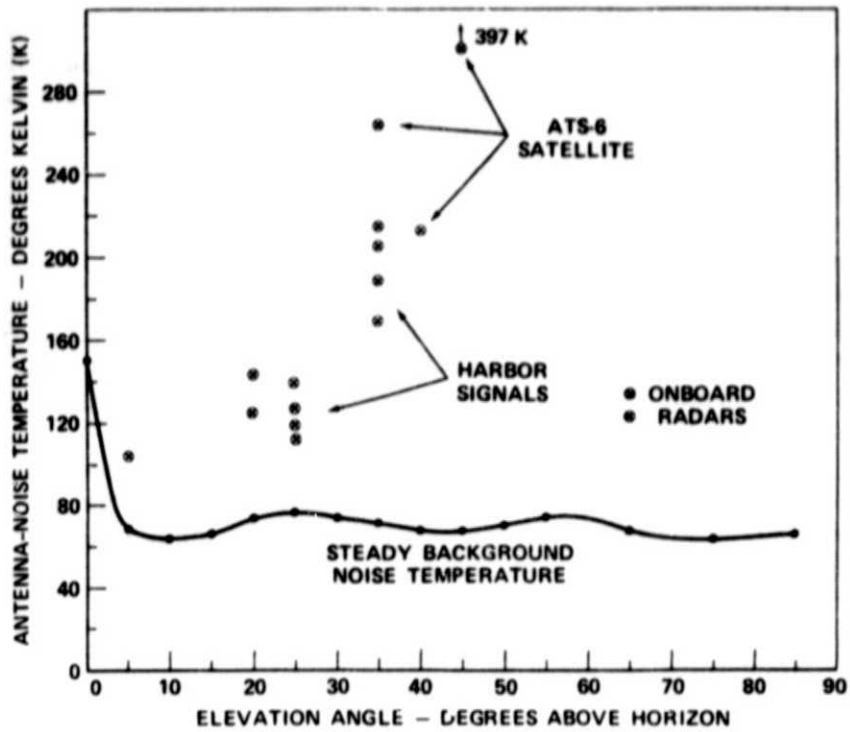

Fig. 4. 1.2 m (4 ft) dish antenna-noise temperature vs. elevation angle in harbor 1.6 GHz data "American Alliance."

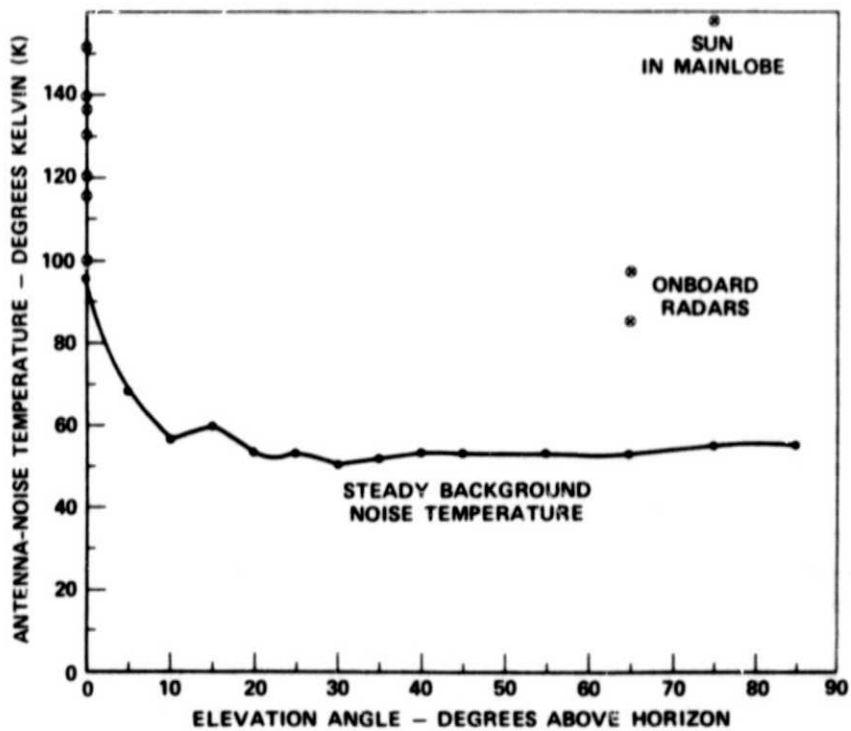

Fig. 5. 1.2 m (4 ft) dish antenna-noise temperature vs. elevation angle at sea 1.6 GHz data "American Alliance."

Conclusions. - Extensive antenna-noise temperature measurements at 1.6 GHz (L-Band) were made with a radiometer, and liquid nitrogen 77 K cold-temperature reference load, using a 1.2 m-diameter parabolic dish antenna positioned on a commercial-container cargo ship. Both in-harbor and at-sea antenna-noise temperature measurements were made at 1.6 GHz. Steady background, antenna-noise temperature measurements, slightly less than 70 K, were obtained at elevation angles of 5°, and greater, at 1.6 GHz, being equivalent to a ground-based antenna. A comparison of theoretical and measured values, for at-sea data, indicate excellent agreement within about 5 K.

Acknowledgment. - The authors would like to thank Mr. Daniel Brandel, National Aeronautics and Space Administration, Goddard Space Flight Center for his helpful suggestions.

Also, the authors would like to thank Mr. Harry A. Feigleson, Research and Development Program Manager, U.S. Maritime Administration; Captain W. F. Kolbe, Jr., Marine Superintendent, and Captain Hance E. Heather, Master, SS American Alliance, United States Lines, Inc. for their cooperation and support.

REFERENCES

- [1] "In-Harbor and At-Sea Electromagnetic Compatibility Survey for Maritime Satellite L-Band Shipboard Terminal." Prepared for NASA/Goddard Space Flight Center, Greenbelt, Maryland (USA) under sponsorship of U.S. Department of Commerce, Maritime Administration under NASA Contract NAS 5-24035 by RCA Service Corporation, Springfield, Virginia (USA); August 1974.
- [2] R. E. Taylor and J. S. Hill, "EMI Survey for Maritime Satellite, L-Band Shipboard Terminal," 1st Symposium and Technical Exhibition on Electromagnetic Compatibility, Montreux, IEEE 75CH1012-4 MONT, pp. 381-387; May 20-22, 1975.
- [3] R. H. Dicke, "The Measurement of Thermal Radiation at Microwave Frequencies," The Review of Scientific Instruments, Vol. 17, No. 7, pp. 268 - 275; July 1948.
- [4] John D. Kraus, "Radio Astronomy." McGraw-Hill Book Company, Chapter 7: Radio-Telescope Receivers; 1966.
- [5] L. V. Blake, "Antenna and Receiving-System Noise-Temperature Calculation." U.S. Naval Research Laboratory (NRL) Report 5668, (USA National Information Technical Service Report No. N63-80893, Springfield, Virginia 22151), Washington, D.C. (USA); 19 September 1961.