

**NASA TECHNICAL
MEMORANDUM**

NASA TM X-71790

NASA TM X-71790

AN AUTOMATED ATMOSPHERIC SAMPLING SYSTEM
OPERATING ON 747 AIRLINERS

by Porter Perkins
Lewis Research Center
Cleveland, Ohio 44135

and

Ulf R. C. Gustafsson
United Airlines
San Francisco, California

TECHNICAL PAPER to be presented at
International Conference on Environmental Sensing and
Assessment sponsored by the Institute of Electrical
and Electronics Engineers
Las Vegas, Nevada, September 14-19, 1975

AN AUTOMATED ATMOSPHERIC SAMPLING SYSTEM
OPERATING ON 747 AIRLINERS

Porter J. Perkins
NASA - Lewis Research Center
Cleveland, Ohio

Ulf R. C. Gustafsson
United Airlines
San Francisco, California

Summary

3-8455
An air sampling system that automatically measures the temporal and spatial distribution of particulate and gaseous constituents of the atmosphere is collecting data on commercial air routes covering the world. Measurements are made in the upper troposphere and lower stratosphere (6 to 12 km) of constituents related to aircraft engine emissions and other pollutants. Aircraft operated by different airlines sample air at latitudes from the Arctic to Australia. This unique system includes specialized instrumentation, a special air inlet probe for sampling outside air, a computerized automatic control, and a data acquisition system. Air constituent and related flight data are tape recorded in flight for later computer processing on the ground.

Introduction

This paper describes an automated, unattended air sampling system which measures and records the levels and distribution of selected atmospheric constituents in the upper atmosphere. This system is installed and operated on commercial 747 airliners during normal passenger service along established airline routes.

The effect of man on the global environment was examined in two intensive studies conducted in 1970 and 1971: "MIT Study of Critical Environmental Problems (SCEP)"¹ and "MIT Study of Man's Impact on Climate (SMIC)"². Both studies raised serious questions regarding the eventual effect of high altitude aircraft operations on the environment. The Climatic Impact Assessment Program³ established by Congress in the Department of Transportation in 1971 studied the potential climatic impact resulting from perturbation of the upper atmosphere by the propulsion effluents of worldwide high-altitude aircraft fleet beyond 1980. All three of these studies emphasized the urgent need for detailed measurements of natural composition of the upper troposphere and the lower stratosphere. Also recommended were continuous atmospheric monitoring and research programs to obtain additional knowledge of the upper atmosphere and to detect changes in atmospheric quality. Since the atmosphere has no horizontal boundaries, these programs must be conducted on a global scale.

In 1972 the NASA-Lewis Research Center began a program which became known as the Global Atmospheric Sampling Program (GASP). The objective was to examine the atmosphere between 6 and 12 km using commercial airliners as instrument platforms. This program was described at the Second Joint Conference on Sensing of Environmental Pollutants (Dec. 1973).⁴ The concept of using airliners to obtain atmospheric data has progressed from design and acquisition of hardware to collecting global data on a daily basis.

Airlines presently participating in the programs are shown in figure 1. GASP systems are now operating

on a United Airlines 747 and a Pan Am 747. A Qantas Airways 747 will be equipped in November, and a fourth GASP equipped 747 will be operating in early 1976. The present GASP route structure is shown in figure 2. The United airliner is collecting data over the continuous United States and to Hawaii. Global coverage is provided by the Pan Am 747. World routes include around-the-world eastbound and westbound, to South America from New York and Los Angeles, to Australia from the United States, and northern latitudes on non-stop flights from the west coast of the United States to Tokyo and to Europe. Participation by Qantas Airways of Australia will provide global data over routes which include the less polluted Southern Hemisphere. The program is structured to obtain global air quality data during routine airline operations and to document and analyze these data for a period of 5 to 10 years.

The government supplied the instruments and air sample pressurization system. United Airlines, as prime contractor, designed and supplied all other components of the system. Integration of the complete system and its installation on the 747 aircraft were also done by United Airlines.

This report describes (1) the overall unique onboard system which collects atmospheric constituent data automatically and unattended on commercial 747 airliners; (2) the environmental measuring instruments with modifications necessary for airline application along with the air sampling system; (3) details of the onboard computer for automatic control and data management; and (4) maintenance procedures that have been established to catch operating problems early and obtain maximum equipment utilization.

Design Constraints and Atmospheric Constituents

Design Constraints

A 4-month feasibility study by three airlines (American, Trans World, and United) and the Boeing Company was conducted in 1972 to determine the technical feasibility of operating an atmospheric sampling system on commercial air transports. This study produced the basic system concept and imposed certain constraints on the design and operation of the system. The constraints were as follows:

- No revenue space would be taken from either the passenger compartment or the cargo hold. Windows would not be blocked.
- The system would not interfere with normal scheduled operation of the aircraft.
- No cockpit crew duties would be imposed beyond monitoring of a fault light and operation of an ON/OFF switch if the fault light appeared. The cockpit crew would at all times have control over system power.
- Limited servicing and maintenance would be performed on a noninterference basis, mostly overnight.

- All units must be packaged to airline standards⁵ and tested to show aircraft environment compatibility.⁶
- The aircraft would not be removed from service exclusively for system installation for any lengthy period of time. Kits could be installed in limited time increments during out-of-service periods scheduled for other purposes.

After considering the economics and space available on other airplanes, the Boeing 747 airplane was selected as the carrier aircraft. It has sufficient volume in nonrevenue compartments to contain the system. The 747 was chosen also because of its long-range capability, worldwide usage, and being equipped with inertial navigation systems. Thus, the final design of the system as a result of the feasibility study was dictated first by the initial airline constraints and second by technical and economic considerations. Eliminated from consideration were window-mounted probes and instruments in pallets, or cargo containers bolted down to standard fittings, either above or below the main deck. The alternatives were special inlets penetrating the skin and special mounts for all equipment. These required more airframe modifications, more engineering, and added structures. An automated system which can produce reliable data over a reasonable time period with no human attention is more costly than a system which is continuously monitored and serviced. However, the crew noninterference requirement necessitated the design of an automated, processor controlled system.

The levels of the minor constituents measured by the GASP system are extremely low, generally in the low parts per million to parts per billion range. These are difficult measurements, particularly for airborne instruments, and require a high degree of cleanliness throughout the system. Since aircraft are subjected to relatively high levels of contamination at low altitudes and on the ground, a sealed system, opened only to take data, was considered mandatory. The inlet and method of closure have to be both functional and esthetically acceptable to the airlines. Not sealing the inlet and depending on purging to clean out the contamination was considered a speculative approach and not used.

There are a number of potential sources of contamination. On the ground there is exposure to engine exhaust fumes from other aircraft. The airplane is sometimes cleaned with solvent and a high-pressure water hose. The nose wheel sprays the fuselage with rubber particles, dirt, and water. There may be blowing dust, and in metropolitan areas there is a concentration of smog constituents which may persist during climb and descent. In flight, the boundary layer contains erosion particles from the radome, skin, and painted surfaces, and there may be leakage of cabin air, hydraulic fluid, lubricants, and windshield cleaning fluid. These contamination sources were considered when locating and designing the inlet for a clean system.

After considering these factors and others related to the aerodynamics affecting aircraft systems and the damage potential while on the ground, an air inlet probe was mounted at the bottom of the fuselage near the nose of the airplane at station 160 (fig. 3). This is a clean area with a thin boundary layer. Automatic control devices open the inlet probe at a 6-km altitude on ascent and close it at the same altitude on descent.

Atmospheric Constituent and Related Data

The upper atmosphere constituents that are measured (or will be measured in the near future) and related information needed for data analysis are shown in table 1. The constituents are divided into two major groups - particulates and gases. In the particulate group, the number density and the size distribution are measured by a dedicated instrument on a continuous basis. Mass concentration and chemical composition are obtained by periodically collecting a filter sample. Laboratory analysis techniques are then used to determine the presence of sulfates, nitrates, and carbon on the filter. The gases are determined from in-situ measurements using dedicated instruments operating continuously; the chlorofluoromethanes, however, are obtained by a laboratory analysis of whole air samples periodically collected in cylindrical containers. This list of measurements contains most of the constituents that are known to be important for determining the potential impact of aircraft emissions on the upper atmosphere plus others, such as the chlorofluoromethanes, which are pollutants injected at ground level. Descriptions of the air constituent measuring instruments are given in a later section of this paper.

In addition to the air sample measurements, data are taken which include geographical information, meteorological conditions, and aircraft operational information necessary to pinpoint precisely the location and describe the conditions when a data point is recorded.

Description of Airborne System

The total GASP system that evolved from the feasibility study is shown schematically in figure 4. The system is installed in the 747 airplane below the floor of the first class passenger section near the nose, extending from aircraft stations 160 to 400. The entire system is forward of the existing avionics rack. The system can best be described by dividing it into four functional categories: (1) the inlet for sample collection, including ducting and sample pressurization and control; (2) instruments for determining the concentration of selected constituents in the air sample; (3) data acquisition, management, and recording; and (4) a preprogrammed automatic control for the entire system.

Ducting from the air sample inlet probe directs the air to filters on the right side of the aircraft for collecting particles, and it also directs the air to the system on the left side which pressurizes the air sample and measures the air constituents (see fig. 4). Air from the filter unit is vented overboard on the right side. Another vent on the left side discharges the air from the instruments.

Most of the measuring and data acquisition and control equipment is located on the left side of the fuselage, opposite the nose wheel well. The equipment is installed in racks attached to the aircraft structure. The close proximity of the GASP equipment to the existing aircraft avionics rack allows for short wiring runs and for ease of installation and integration with the inertial navigation system and the air data system, both of which are necessary to provide aircraft related supplemental data. The location chosen is easily accessible for inspection, tape removal, and service.

Air Inlet and Sample Pressurization

The air sample for the GASP measurements required two separate inlets outside of the aircraft in order to measure both gases and particles. A separate inlet is needed to measure the size distribution of particles. Isokinetic sampling (probe inlet velocity equal to free stream velocity) is required to obtain an undistorted measure of particle size distribution. A single air inlet would not provide isokinetic sampling because the flow rate to the instrument package and filter collector varies under operating conditions. Also, flexibility was desired in the system to add instruments which would also vary the flow requirements.

Generally, unpressurized air is desirable to avoid interference with the constituent to be measured. However, a pressurized air sample is desirable for some measurements in order to achieve the necessary instrument sensitivity.

Air inlet probe. The two air sample inlets are mounted one above the other in a single strut, using a single probe cap unit with its associated actuator. The probe cap is anti-iced when extended. A sketch of this dual probe is shown in figure 5. The probe is shown in the capped condition. In flight, above sampling altitude, when the inlets are opened, the probe cap is rotated into the probe cap housing by an aircraft-type actuator and becomes flush with the aircraft skin. The housing is a pressure-tight box mounted inside the aircraft. The design drag at $M = 0.92$ and at a 7.5-km altitude is 7 kg.

Air enters the gas sample probe through a 25-mm-diameter inlet. This probe also supplies air to the particle filter, which does not require isokinetic sampling. It is, however, important to reduce the air velocity to the filter to avoid loss of particles by impaction on the walls at bends in the ducting and to minimize pressure losses. Air in the 25-mm-diameter tube is therefore expanded through a diffuser into a 76-mm-diameter duct to reduce the velocity. Air to the gas sampling instruments is tapped from the expanded duct at the diffuser exit with a 12-mm-diameter probe.

Air enters the outermost particle counter probe through a 6.9-mm-diameter inlet. This probe is 100-mm (about three times the boundary layer thickness) from the aircraft skin. Isokinetic sampling for the particle counter probe required a more sophisticated design than for the nonisokinetic gas sampling. The flow rate required by the particle counter of about 30 liters/min. results in an extremely small size inlet if inlet velocity were to equal the free-stream velocity of about 0.8 Mach. An inlet having about a 6.9-mm diameter was considered as small as practicable for particle sampling. These constraints resulted in the following design approach.

The sample air entering the 6.9-mm probe is expanded through a diffuser into a larger diameter tube to reduce velocity. A secondary probe of about the same size located in the low velocity region of the larger tube provides the proper airflow to the particle counter. The excess air caught by the primary inlet is exhausted at the rear of the expanded tube through a properly sized orifice, which required knowledge of the pressure at this location on the aircraft. A special static pressure tap was installed, and data were taken in the initial 747 flight. This information and the wind tunnel test results were used to size the exhaust orifice to give isokinetic sampling at nominal cruise conditions of 10.7 km altitude and free-stream Mach number of $M = 0.82$.

Air sample pressurization. Air to the gas sampling instruments that require sample pressurization is pressurized with a diaphragm pump. A flow rate of 14 liters/min. is maintained by the pump at 1 ± 0.007 atm. This pressure is held constant from 6 to 12 km by the pressure regulation system described in reference 7. A simplified flow diagram is shown in figure 6. Basically, a backpressure regulator controls the pressure out of the pump to the instruments by bypassing excess air through it. An absolute pressure regulator, which contains a sealed bellows reference cell, supplies a constant reference pressure to the dome of the backpressure regulator. This system was chosen to avoid possible contamination by passing sample air to the instruments through a regulator. Components of the pressure regulation system are contained in a flow control unit.

The pump is mounted in a separate unit which also contains relays and thermostats used for control and safety. Pressure switches protect the system from overpressure and underpressure. A pressure relief valve is used as a safety backup to the overpressure switch.

Equipment Rack

The main GASP units are mounted on a rack on the left side of the aircraft as shown in figure 4. Four shelves provide about 5 m of linear shelf space. At the present time, eleven units are contained in the rack and four more are planned, which will fill the available space. Restrictions are placed on the size, weight, and center of gravity of the shelf-mounted units to conform to the structural design. The rack also supports a main distribution panel for circuit breakers, relays, and rack-to-aircraft connectors for the total GASP system. Figure 7 shows the present equipment mounted in a ground-test mockup rack.

System Power and Weight

The GASP system is powered by the aircraft by means of a three-phase contactor controlled by a circuit breaker in the cockpit so that the flight crew can remove the GASP electrical load under abnormal conditions, like certain failures of the aircraft electrical system. Whenever power is removed, the system resets to the sealed shutdown configuration. The initial GASP system weighed 274 kg, and the final weight by 1976 with all equipment installed will approach 450 kg.

System Control

All GASP system operations are controlled by the processor - a small (8 K memory) special purpose computer. The simplified block diagram in figure 8 shows the interrelationship between the data acquisition and system control subsystem and the rest of the GASP system and the aircraft. After power turn-on and system reset, the processor, upon receiving a signal for 6 km altitude, opens the air inlet and the vents, starts the pumps, and sets up the system for sampling. A sampling cycle is 60 minutes long, consisting of twelve 5-minute segments. A 16-second recording is taken at the end of each 5-minute segment. Alternate segments are periods in which the system is put into one of six different calibration modes. The calibration modes make possible a between readings check of the instruments to enhance the confidence in each measurement.

A particle filter is exposed every third day, if an unexposed filter is available for exposure. The exposure occurs at an altitude above 9.6 km for a normal

period of 2 hours unless an earlier descent below 9.6 km is experienced. Normal system operation is interrupted only during insertion and retraction of the filter. Also, whole air sample, for later measurement of chlorofluoromethane, is taken in level flight at altitudes above 9.3 km on every third day if a sample bottle is available. Normal system operation is also interrupted during the sampling process which involves purging the bottle with unpressurized air for 5 minutes prior to sealing the bottle.

During the descent, when below 6 km, the processor shuts down and resets the entire system to be ready for the next flight.

The processor can also recognize certain major failures and modify the system setup accordingly. In case of major data acquisition or system control problems, a light goes on in the cockpit requesting the flight engineer to deactivate the GASP system until it is checked out. If the air inlet does not open at 6 km, the flow system is not activated, but other measurements, such as water vapor and meteorological data, will be recorded.

Most of the system control time constants or trigger levels can be altered by a simple entry from a carry-on panel. This includes parameters such as recording time, filter exposure time, particle count time, bottle sample purge time, record interval, sample, filter or bottle sample altitude, acceleration limits, etc. The carry-on panel will also allow inflight monitoring of the system during which an observer may completely take over system control to evaluate alternate control sequences without reprogramming the processor. The panel also displays real time data readings in engineering units.

The program for the processor is on paper tape, and it may be electronically loaded into the processor memory on the aircraft using a carry-on loader/reader.

Data Acquisition

The processor also controls data acquisition and data recording. Special records are taken at takeoff and landing to allow a determination of flight end points by latitude/longitude.

The data acquisition subsystem reads data from the measuring instruments, plus it gets supportive data from the flow system, including pressures and temperatures. Status information from the GASP system, including valve positions, failure flags, instrument identification signals, etc., are also recorded. In addition, aircraft flight data are collected at the time data are read from the measuring instruments. Position, heading, and the computed wind direction and velocity are obtained from the inertial navigation system. Altitude, airspeed, and static air temperature are collected from the central air data system in the aircraft. Vertical acceleration information (an indication of turbulence) is taken from the aircraft flight recording system. Date and time are provided by a separate GASP clock-calendar unit.

Vertical acceleration is always recorded as part of the normal data and in case of encountering severe turbulence (which is presently set in the processor at less than 0.8 G or more than 1.2 G), a special recording is taken. The processor will interrupt normal sequences to take these data when these acceleration limits occur. All data which have been stored in the memory 8 seconds prior to the turbulence encounter will also be recorded. Thus, information

shortly before the acceleration limits are encountered is obtained. The special recording will continue for 60 seconds after the acceleration limits have ceased. The acceleration is sampled 8 times per second.

All analog data are digitized, and digital data are reformatted by the data acquisition system under control of the processor and outputted to a digital cassette recorder. Analog parameters are typically digitized into a 12-bit word with an accuracy of 0.25 percent. The cassette has a capacity for more than 6 weeks of data at the GASP recording rate. The cassette data are transcribed on the ground onto computer compatible tape, which provides the raw input data for processing at NASA-Lewis Research Center.

Data Acquisition and System Control Components

All major components of the data acquisition and system control are airborne type equipment. The processor, system control functions, and certain data acquisition functions are combined in a Data Management and Control Unit (DMCU). This unit was obtained by modifying a Data Management Unit (DMU) as used by several airlines. Most of the aircraft data acquisition is handled by a standard Flight Data Acquisition Unit (FDAU) as defined in ARINC Characteristic 573⁸. The digital cassette recorder is the Digital AIDS recorder (DAR) used by several airlines for onboard data recording.

Measurements

The instruments for measuring carbon monoxide (CO), ozone (O₃), water vapor, and particles were developed by NASA-Lewis from commercially available units. The flow control system was also developed by Lewis to provide the 1-atm. controlled pressure to the instruments. United Airlines integrated the measuring equipment with the DMCU, FDAU, and recorder and supplied all the supporting wiring and aircraft interconnects. All of the equipment is packaged to fit in standard ARINC type ATR cases⁵; it has been FAA certified for flight operations in accordance with environmental test procedures established by the Radio Technical Commission for Aircraft (RTCA)⁶ and by the Boeing Company.

Ozone Monitor

This instrument uses the ultraviolet absorption principle to measure ozone. Sample gas and ozone-free zero gas (obtained by passing sample gas through an ozone destruction filter) are alternately passed through a 70-cm-long tube. The difference in intensity of an ultraviolet beam traversing the same path length is a measure of ozone concentration. The range is from 0.003 to 20 ppm. Sensitivity is 3 ppb. An automatic zero correction to within 1 ppb is provided.

The ozone monitor is calibrated against a laboratory type ozone generator over the range from 0 to 1 ppm. The ozone concentration of the generator is periodically calibrated by the 1 percent neutral buffered potassium iodide method.

In-flight "zero" and "calibration" readings made on the ozone instrument include the following:
(1) measurement of instrument zero by flowing the sample through a charcoal filter external to the instrument, (2) measurement of "sample" and "reference" frequencies available from within the instrument, and (3) measurement of the span setting of the instrument. The values of the "sample" and "reference" frequencies

must be within known limits for proper operation. Deviations from original values will indicate dirt on the optics, a shift in the position of the ultraviolet source or the detectors, and a change in the intensity of the ultraviolet source.

In-flight calibration, using an ozone calibration gas, is not made because of the difficulty of generating a precisely known ozone concentration in the flight system. A policy of periodic laboratory recalibration of the instruments is followed. If sequential calibrations do not agree within specified limits, the data preceding the changed calibration are discarded.

A further concern in the ozone measurement is the destruction of ozone in the lines from the inlet probe to the instrument and in the sample pump that raises the sample pressure to 1 atm. The lines are Teflon, and the pump is a Teflon-coated diaphragm pump. Ozone destruction through the system has been measured under conditions simulating operation in flight. Ozone destruction is approximately 40 percent at 20 ppb, but reduces to 9 percent at 500 ppb. The ozone destruction data are used as a correction in the data reduction.

Water Vapor Monitor

This instrument is an aluminum oxide hygrometer and consists of two units; a sensing element and an electronics unit. The sensing element uses a separate externally mounted probe. This probe is the standard type airscoop used on the 747 aircraft to measure outside air temperature but with the temperature sensor removed. This type of housing was chosen for the sensor because of easy adaptability and the convenience of using standard aircraft parts including a required anti-icing heater. The scoop is mounted on the exterior of the aircraft near the air sample inlet probe (see fig. 3) and is not capped at any time.

The electronics unit is mounted in the GASP equipment rack. The electronic circuit of the hygrometer is standardized by the manufacturer to work with any sensor. The electronic circuit includes a relay operated calibration function, which substitutes a dummy impedance for the water vapor sensor to provide a 90 percent of full scale output signal. The electronics circuit also has a temperature measurement channel for measuring the temperature of the air passing over the water vapor sensor.

In-flight calibration checks for this instrumentation consist of periodic recording of the output of the system with the dummy impedance substituted for the sensor.

The water vapor instrumentation provides dew-frost point temperatures (DFPT) over two ranges (-110° to -20° and -20° to $+40^{\circ}$ C) and also provides for an air temperature measurement at the sensor from -65° to $+40^{\circ}$ C. The temperature is measured with a thermistor mounted in the sensor probe. Both the DFPT and temperature output signals are 0 to 5 VDC.

The sensors are calibrated both by the manufacturer and NASA. The manufacturer's calibration on DFPT is specified to be within $\pm 2^{\circ}$ C over the range $+40^{\circ}$ to -65° and $\pm 3^{\circ}$ C over the range -65° to -110° C. The calibration system used at NASA uses dry nitrogen gas (DFPT of -70° C), service air (DFPT of approximately -40° C), and room air. Appropriate mixtures of nitrogen gas and air are used for calibrating over the range of DFPT from 0° to -70° C. The DFPT of the resultant gas is measured with a cooled mirror type hygrometer to within $\pm 0.5^{\circ}$ C. The uncertainty of the DFPT calibration procedure is less than $\pm 2^{\circ}$ C over the range from

0° to -70° C.

The stability of the calibration of this instrumentation is primarily dependent on the stability of the calibration curve of each sensor. Sensors are periodically removed from the aircraft for NASA laboratory recalibration, and the data are discarded if they do not agree within the uncertainty of the calibration system. Data reduction requires the specific calibration data for each sensor; a sensor identification system is necessary to accomplish this.

Temperature effects on the calibration of the sensors are significant. Correction terms are provided in the data reduction process using data from the air sample temperature thermistor mounted with the sensor. A contamination of the sensors also changes their calibration. Salt corrosion has been found to be an occasional contamination problem with this sensor in the 747 installation.

Particle Counter

This instrument utilizes the light-scattering principle to measure the number density and size distribution of airborne particles above a 0.3-micron diameter. It consists of two units: (1) a sensing unit mounted near the inlet probe, which contains the light source and optics; and (2) an electronics package mounted in the equipment rack, which contains the counting circuits and pulse height discriminators to measure the particle size distribution.

The instrument accumulates a count of the number of particles in the air sample flow for a fixed period of time, normally 1 minute. The accumulated count is separated into five different size ranges: 0.3 to 0.45, 0.45 to 0.65, 0.65 to 1.4, 1.4 to 3.0, and above 3.0 microns in diameter. One of the modifications to this instrument is the addition of an electronic servo to automatically adjust the gain of the sensing unit (optics, photomultiplier tube, and preamplifier) to the correct value for the size discriminator circuits. This servo replaces the conventional manual gain adjustment. The gain circuit is energized to readjust the gain prior to each counting cycle. The sample flow rate through the sensing unit (30 liters/min.) is measured using a choked venturi flowmeter.

Each instrument is calibrated by the manufacturer for particle size detection. This calibration is checked at NASA-Lewis using an aerosol generator and latex aerosol particles.

This instrument has two discrete output signals to indicate proper operation. One of these indicates that the light source has remained on during a full counting cycle. The other indicates that the automatic gain adjustment was completed prior to a counting cycle.

Flight test experience with a commercial version of this instrument indicated that flight through a cloud resulted in a particle size distribution that is significantly different from that of a clear air sample, mainly in the total count of the largest size particles. A simple cloud detector is, therefore, obtained by observing the counting rate of the largest size particles. A modification of the particle counter instrument to provide a count rate that is related to cloud density supplies cloud detector capability for the GASP systems.

Carbon Monoxide Monitor

A nondispersive infrared analyzer, using a dual-isotope fluorescence principle is used to measure carbon

monoxide. Modifications of a commercial 0 to 20 ppm full-scale analyzer to 0 to 1 ppm are necessary to achieve the required sensitivity of 20 ppb for high altitude measurements. A prototype instrument having this low range sensitivity has been successfully flight tested and is being acquired for installation on the GASP system in the near future. At the present time, the less sensitive instrument (0 to 20 ppm) is being flown to gain operational experience with this type of instrument in the GASP system.

The CO instrument is calibrated at Lewis using a commercially prepared gas mixture of approximately 18 ppm CO in N₂ combined with a dilution process.

In-flight tests on this instrument include a zero test and a test to measure the gain of the electronic circuit. Zero gas is obtained by flowing the sample through a tested CO destruct filter. In addition, two discrete signals are recorded, which indicate that the detector temperature is within acceptable limits and that the preamplifier is operating within prescribed limits. In-flight calibration of this instrument, through the use of bottled calibration gas on the airplane, is not made. Instead, the CO instrument is periodically removed and recalibrated in the laboratory following the same policy of discarding data when calibrations change.

Data are sampled from the CO instrument at a rate of once per second during the 16-second data recording periods. In addition to this, the computer capability in the DMCU is used to accumulate 3-minute averages of the output of the CO instrument during both normal sampling and zero gas portions of the cycle. The values of the 3-minute average and the variance of the average are recorded as additional data during the 16-second data recording periods. This averaging technique is being used to reduce the effects of a low frequency random drift, which is a characteristic of this instrument.

Chlorofluoromethane Sample

This unit, mounted in the GASP equipment rack, consists of four 1-liter stainless steel bottles in which whole air "grab" samples are collected. The bottles and associated seal-off valves and plumbing are contained in a standard aircraft case. The entire case is replaced after all four bottles are filled with the desired whole air samples.

Particulate Filter Collection Unit

This unit is mounted separate from the other GASP equipment because of its size, weight, and need for a high volumetric flow rate. The assembly uses one filter holder providing only one exposure between servicing periods. A unit of several individual filter holders which can be sequentially exposed will replace the single filter assembly in the near future. Each filter (paper or glass fiber) is enclosed within a clean room assembled cartridge to prevent contamination. A filter element is inserted into the 76-mm-diameter duct for 2 hours and retracted into the cartridge by an actuator assembly developed at Lewis. During insertion and retraction the airflow in the duct is stopped by a valve downstream of the filter unit. Airflow through the filter is measured by a venturi downstream of the filter unit.

Analysis of the filter elements at NASA consists of (1) combustion gas chromatography for determining carbon concentrations, (2) a flame emission spectrophotometer for determining concentrations of sulphates,

and (3) an electrochemical technique of determining nitrate concentrations.

Future Measurements

Oxides of nitrogen, carbon dioxide, and condensation nuclei are not being measured by the GASP system's currently in operation. Work is in progress, however, to add instruments for these data in the near future. The four instruments and the particle filter now contained in the system were selected and modified in time to meet the initial GASP installation schedule. NO, CO₂, and nuclei are more difficult to measure in flight, and, therefore, acceptable instruments have taken more time to develop. Flexibility has been built into the overall GASP system to accept these or other constituent measuring devices that may be pertinent to the study of upper atmosphere air quality.

Data and Data Processing

Data from Airlines

Each 747 aircraft operates approximately 10 hours per day. The GASP system takes a data point every 5 minutes above a 6-km altitude. In some instances the time between measurements may be extended to 10 minutes, depending on whether calibration or status information was obtained at the 5-minute point. This means data are taken approximately every 75 km (47 miles), resulting in about 120 data points per day received from each aircraft.

Data from NASA Aircraft

In addition to the GASP data from the airline routes that are obtained from the commercial 747's, two NASA aircraft are being used to help develop measurement and analysis techniques and to obtain off-route and supplemental data. The Ames Research Center CV-990 is being used extensively to flight test all of the instruments currently used on the 747's and, at the same time, to acquire supplemental atmospheric data. An automated GASP system will be built and installed on this aircraft on a semi-permanent basis. This will allow off-route data to be obtained during normal aircraft flight experiments and also during dedicated flights to specific localities.

One of the Lewis Research Center's F-106's is also being used to support the development of GASP instruments and provide atmospheric data. The aircraft is equipped with two particle sampling filter systems located in removable pods attached to the lower surface of the wings. With these pods installed particle samples are being obtained up to altitudes of 13.7 km. (These samples are analyzed at Lewis). This F-106 aircraft is also being equipped to carry the system for obtaining high altitude "grab" samples, which will be analyzed for chlorofluoromethanes.

Data Reduction and Analysis

When all four planned 747 aircraft become operational and the NASA aircraft data are included, large quantities of data will become available. Thus, several computer processing procedures become necessary.

The 747 data along with the off-route and supplemental data obtained by the NASA aircraft will be processed as illustrated on figure 9. The initial data processing step is to compact the data to reduce bulk and to put it in format for subsequent analysis. The data tape contains four types of data: (1) flight data, including date, time, aircraft position, altitude,

heading, winds, and acceleration; (2) status data, identifying instrumentation on board and indicating the operational condition of the inlet probe, pumps, filter, sample bottle, and the several measuring instruments; (3) system data, including temperatures and pressures needed for calculating particle counter and filter flow rates as well as temperatures and pressures required to verify proper system operation; and (4) raw constituent data. The system data, the calibration data from laboratory instrument calibrations, and the calibration data from in-flight calibrations are used in constructing the final constituent data.

Data processing at Lewis also includes dividing the continuous data record into flights, based on flight origin and destination, using the three-letter airport identification codes. For each flight, header information will be attached indicating time of arrival and departure, date, instruments on board, and filter and/or bottle data if obtained. With the header information, data for each flight will be independent to facilitate further analysis which may involve case studies of single flights, groups of flights between the same airports, or examination of seasonal or geographical variation of constituents.

NASA-Lewis will also maintain complete documentation of all data obtained as a function of time, altitude, and location. Specialized analysis will be performed on particle mass concentration and composition, and on selected gaseous constituent variations.

As shown in figure 9, a combined NOAA/NASA analysis will be undertaken to assess potential pollutant emissions effects. NOAA will also perform studies related to meteorology, climatology, and atmospheric chemistry.

A third flow path for the data will be to a NOAA data storage center at Asheville, North Carolina (National Climatic Center) where it will be available to other atmospheric research programs, and to independent researchers on request. NASA-Lewis will periodically publish reports describing the type of data available, and data summaries as appropriate.

Maintenance and Servicing

Much effort has been spent on designing a system that can be maintained and serviced in the airline operational environment and at the same time, can assure a high level of confidence in the collected data. The optimum design servicing interval was set at 14 days, while in reality, due to variations in aircraft scheduling, the interval is from 10 to 21 days. This means that depletable components such as tape cassettes and any calibration gas must last at least 21 days.

Normal servicing at the 2-week interval consists of replacing the tape cassette, filter holder or magazine, and air sample bottle unit. It also includes checking the health of the system and the processor and, if necessary, adjusting the time and day number readings. If any problem is found, troubleshooting is done down to the level of the defective ATR case, and if a spare is available, the faulty case is replaced.

To allow health check and troubleshooting of the GASP system, a special carry-on tester has been developed and the processor has been programmed to assist in the checkout. Data are checked by taking octal readings of certain parameters, and the processor control program is tested through an automatic test sequence. Flow system check and a general operational

check of the system are accomplished by the analysis of a so-called sample frame.

The sample frame, which consists of the last complete set of data and status information at cruise altitude taken during the preceding flight, is displayed on command on the tester. This display tells if the system was properly set up, and if it had any known failures. And, in addition, the display shows system status at cruise level to complement the readings obtained at ground level. The tester display of the sample frame data allows a checkout of the flow system by showing pressures, temperatures, and other pertinent data at cruise conditions. Instrument data readings may be checked to detect gross malfunctions.

To completely troubleshoot the flow system on the ground (if the tester has indicated a problem) a vacuum pump is required. This small, carry-on unit will simulate pressures corresponding to about a 10.7-km altitude by drawing cabin air through the pressurized system. Three special test valves in the flow control unit, controlled by the tester, direct the test airflow.

A report of the findings at every service will be sent along with the data cassette, and if necessary, a further analysis of a particular problem may be made based on this report and the recorded data.

Concluding Remarks

Using commercial airliners as instrument platforms for sampling the atmosphere between 6 and 12 km provides an extensive, continuous, and economical method of global data acquisition. A considerable design effort backed by feasibility studies has made such an approach a reality using 747 airliners. Installation and operation constraints imposed by the airlines have been successfully met by adhering to airline engineering practices and by developing an automated, unattended system.

Significant modifications to the aircraft required obtaining a FAA Supplemental Type Certificate (STC) of airworthiness.⁹ Inclusion of electronic instrumentation and other equipment operating within the aircraft and a tie-in to existing aircraft systems also necessitated meeting certification requirements.

Techniques for insuring the quality of the atmospheric data have been established by using in-flight checks and frequent calibrations. Maintenance and servicing procedures have also been set up to maintain the system and assure confidence in the collected data.

Two 747 airliners equipped with the GASP instrumentation are presently operational. A third airliner will be equipped in late 1975, and a fourth will follow in early 1976.

References

1. Inadvertent Climate Modification - Report on the Study of Critical Environmental Problems (SCEP). Sponsored by Massachusetts Institute of Technology. The MIT Press, Cambridge, Mass., October, 1970.
2. Inadvertent Climate Modification - Report of the Study of Man's Impact on Climate (SMIC). Sponsored by the Massachusetts Institute of Technology. Hosted by the Royal Swedish Academy of Sciences, and the Royal Swedish Academy of Engineering Sciences. The MIT Press, Cambridge, Mass., 1971.

3. Grobecker, A. J.; Coroniti, S. C. and Cannon, R. H. Jr.: Report of Findings - The Effects of Stratospheric Pollution by Aircraft. Office of the Assistant Secretary for Systems Development and Technology. U.S. Department of Transportation, Washington, D.C., December 1974.
4. Perkins, Porter J. and Reck, Gregory M.: Atmospheric Constituent Measurements Using Commercial 747 Airliners. Second Joint Conference on Sensing of Environmental Pollutants, Sponsored by Instrument Society of America, Pittsburgh, Pennsylvania, December 1973.
5. Air Transport Equipment Racking and Cases. ARINC Characteristic Number 404, Aeronautical Radio Inc. Annapolis, Maryland, November 1969.
6. RTCA SC-112, Environmental Conditions and Test Procedures for Airborne Electronic/Electrical Equipment and Instruments. Document Number DO-138, Radio Technical Commission for Aeronautics, Washington, D.C., June 1968.
7. Reck, Gregory M.; Briehl, Daniel and Perkins, Porter J.: Flight Tests of a System to Measure Minor Atmospheric Constituents from an Aircraft. NASA TND-7576, March 1974.
8. Mach II Aircraft Integrated Data System. ARINC Characteristic Number 573. Aeronautical Radio Inc. Annapolis, Maryland, May 1971.
9. Supplemental Type Certificate Number SA2823WE-D Federal Aviation Administration, Washington, D.C., December 10, 1974.

TABLE I. - GASP MEASUREMENTS

PARTICULATES	GASES
NUMBER DENSITY	OZONE
SIZE DISTRIBUTION	WATER VAPOR
MASS CONCENTRATION	OXIDES OF NITROGEN
CHEMICAL COMPOSITION	CARBON MONOXIDE
SULFATES	CARBON DIOXIDE
NITRATES	CHLOROFLUOROMETHANES
CARBON	

RELATED INFORMATION
GEOGRAPHICAL LOCATION
METEOROLOGICAL CONDITIONS
AIRCRAFT OPERATING CONDITIONS

CS-73126



IN SERVICE, DEC 1974



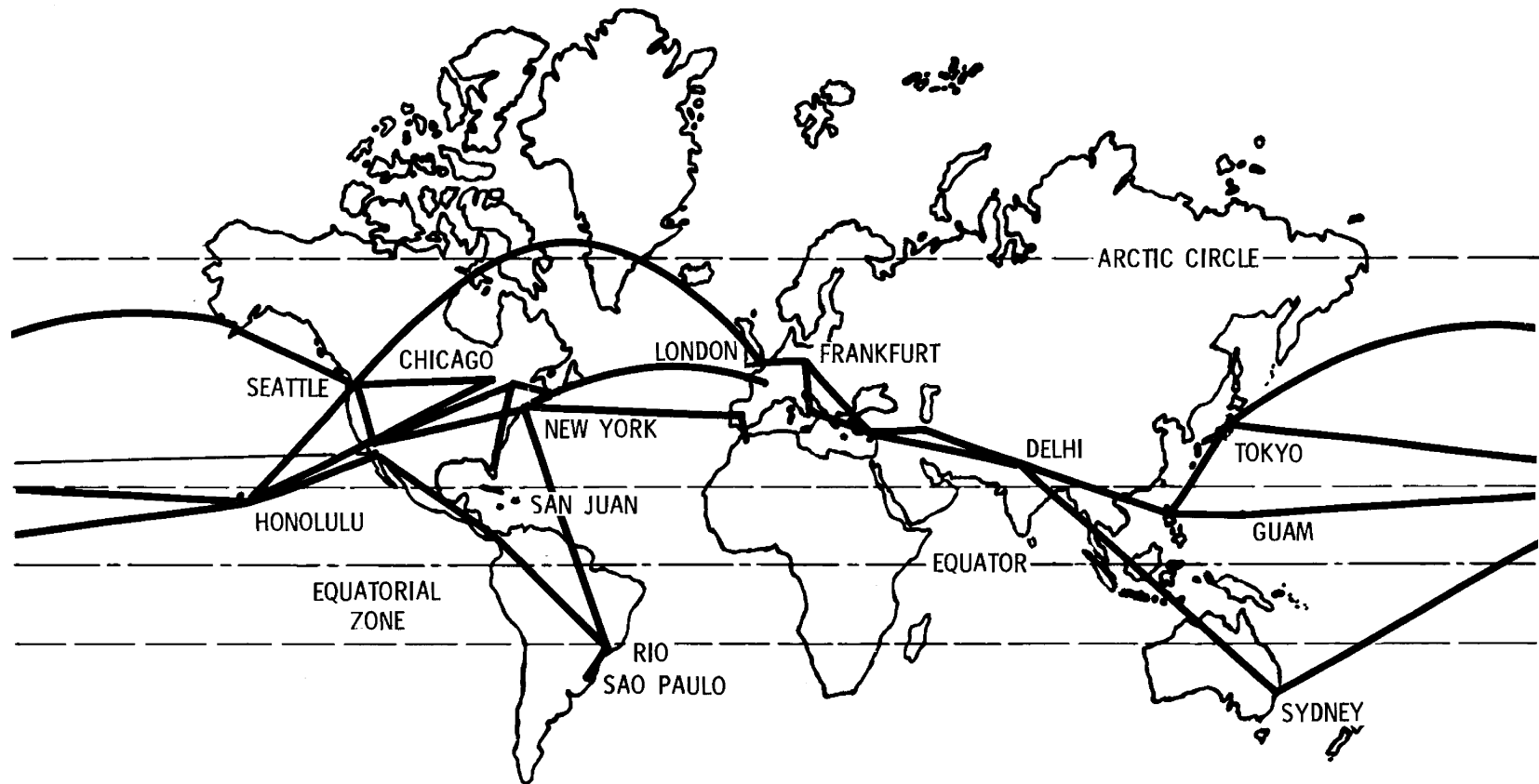
IN SERVICE, MAR 1975



INSTALLATION, LATE 1975

CS-74564

Figure 1. - Airlines presently participating in NASA Global Air Sampling Program (GASP).

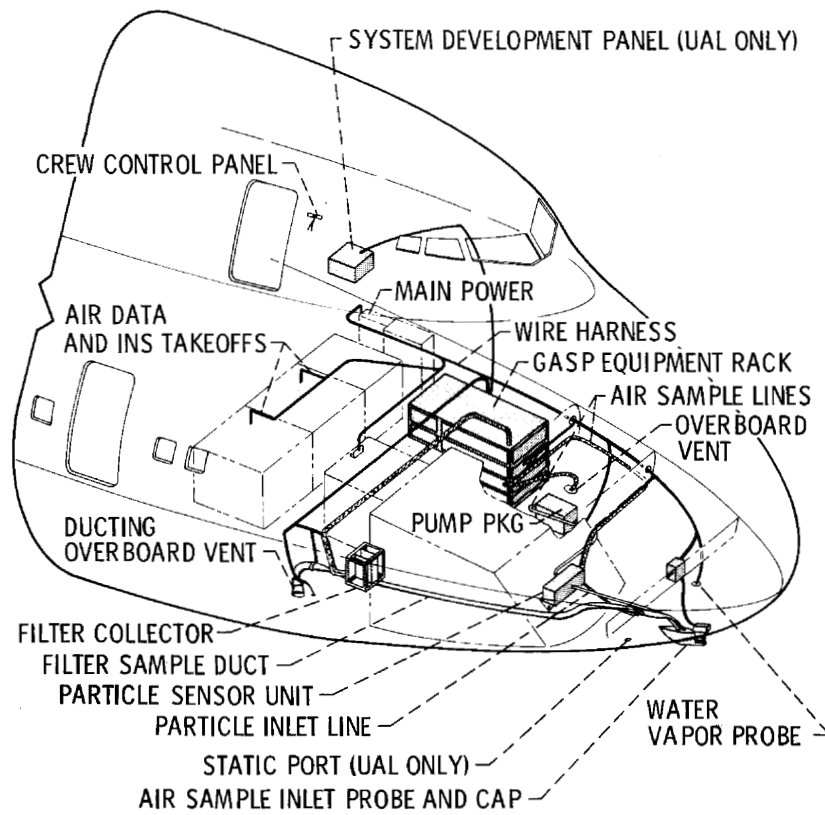


CD-11890-45

Figure 2 - GASP route structure.

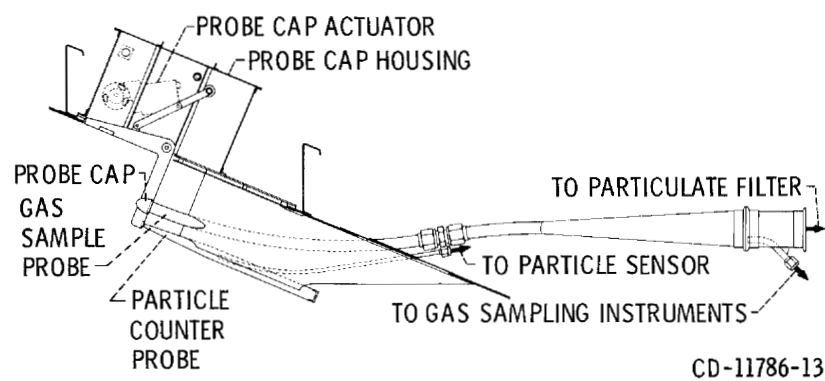


Figure 3. - Air sample inlet probes mounted on 747 airliner equipped for GASP.



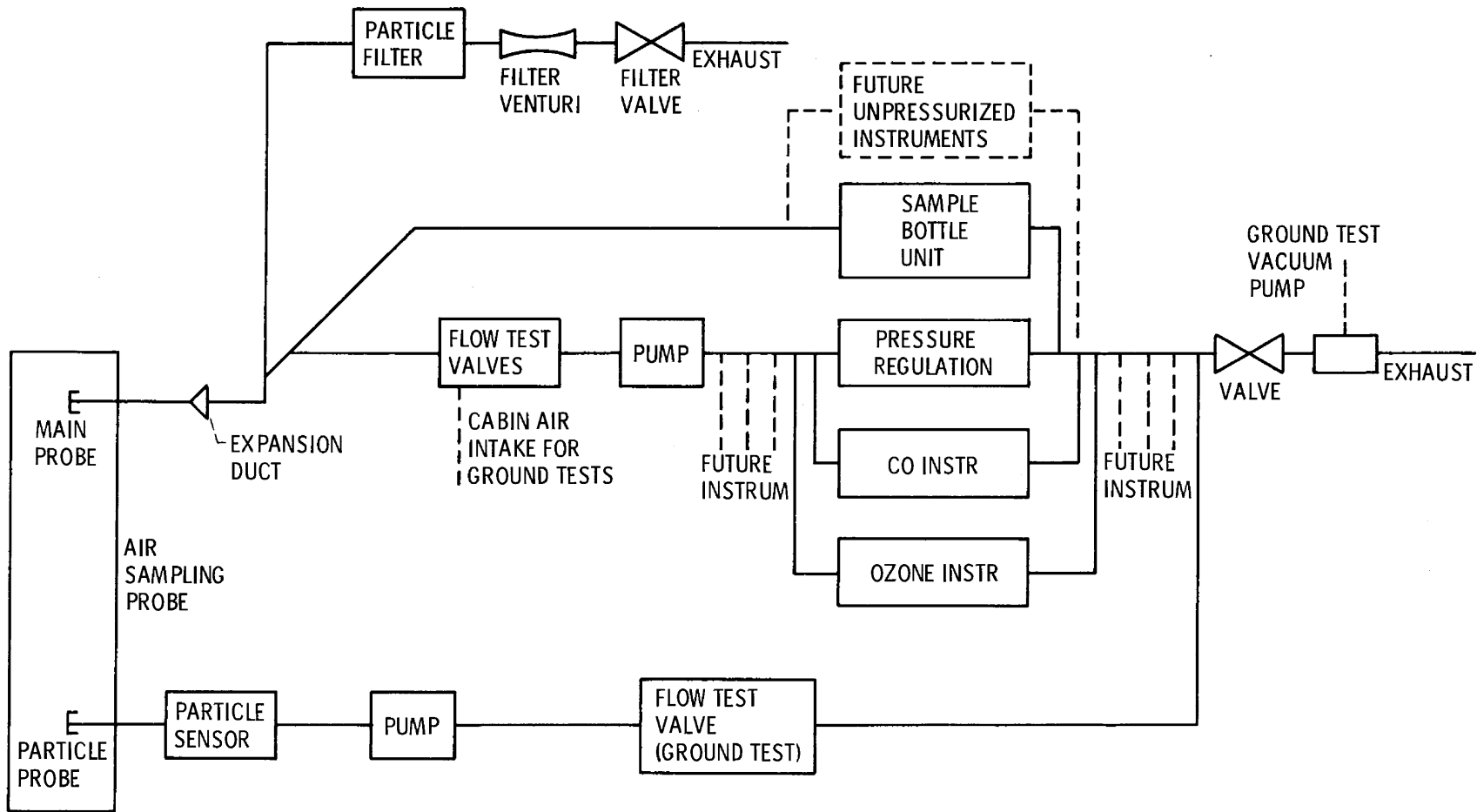
CD-11755-13

Figure 4 - GASP system installation on 747.



CD-11786-13

Figure 5 - Dual GASP air sampling probe on 747 installations.



Simplified GASP air sample flow system diagram.

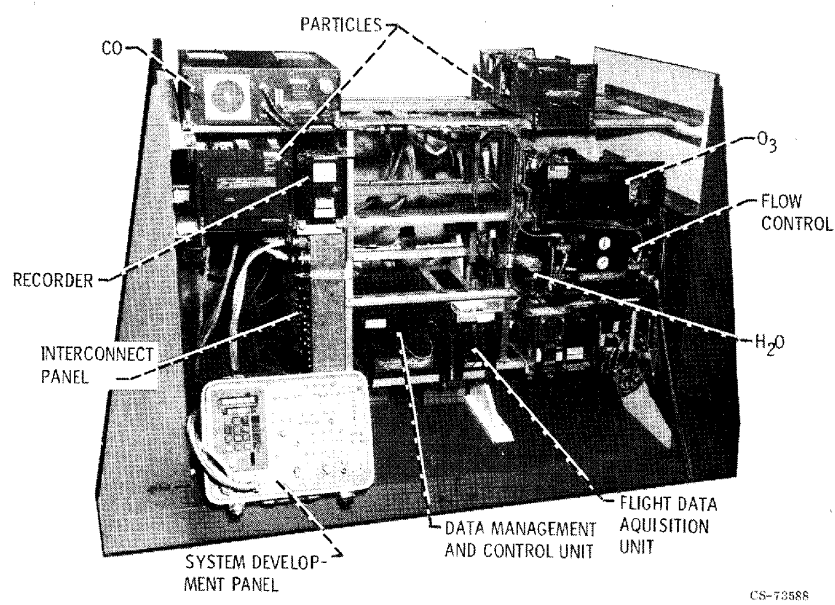
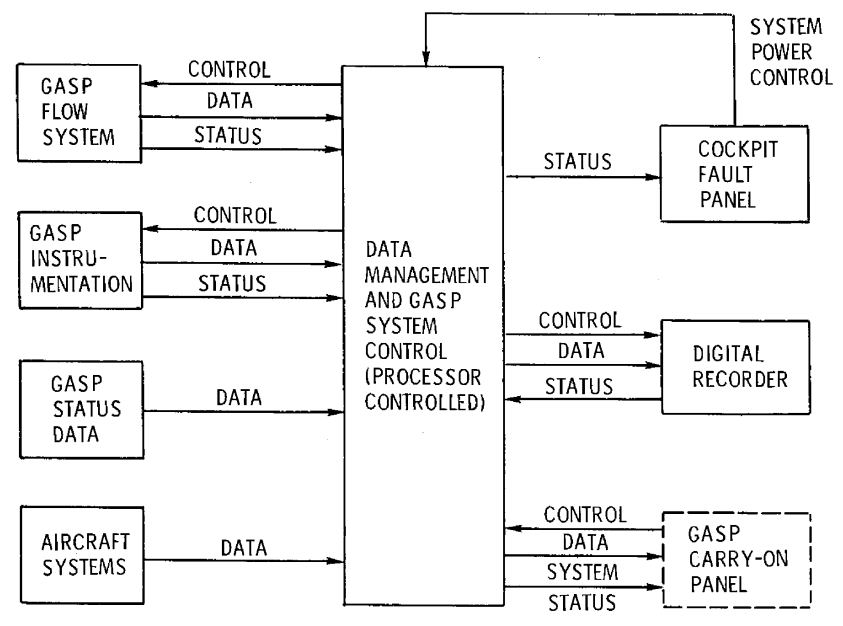
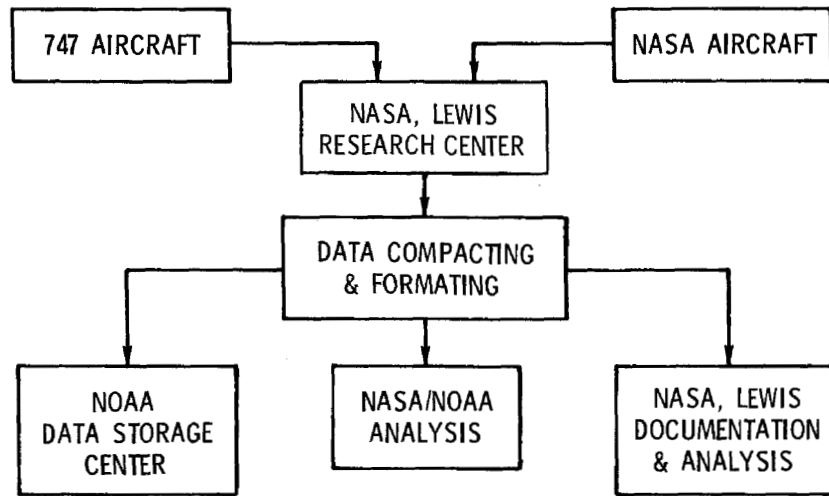


Figure 7. - Ground test mockup of equipment rack for GASP constituent measuring system on 747.



GASP data management and system control.

E-8455



CS-73125

Figure 9. - GASP data flow chart.