

NASA SP-5972 (03)

May 1975

NASA S & T Library
Washington, DC 20546

TECHNOLOGY UTILIZATION

ANALYTICAL AND TEST EQUIPMENT

A COMPILATION



NATIONAL AERONAUTICS AND SPACE ADMINISTRATION

Foreword

The National Aeronautics and Space Administration has established a Technology Utilization Program for the dissemination of information on technological developments which have potential utility outside the aerospace community. By encouraging multiple application of the results of its research and development, NASA earns for the public an increased return on the investment in aerospace research and development programs.

Compilations are now published in one of nine broad subject groups:

SP-5971: Electronics – Components and Circuitry	SP-5976: Mechanics
SP-5972: Electronics Systems	SP-5977: Machinery
SP-5973: Physical Sciences	SP-5978: Fabrication Technology
SP-5974: Materials	SP-5979: Mathematics and Information Sciences
SP-5975: Life Sciences	

When the subject matter of a particular Compilation is more narrowly defined, its title describes the subject matter more specifically. Successive Compilations in each broad category above are identified by an issue number in parentheses: e.g., the (03) in SP-5972(03).

This document is one in a series intended to furnish such technological information. Divided into two sections, the Compilation presents a number of innovations in testing and measuring technology for both the laboratory and industry. Section 1 is devoted to spectrometers and radiometers. Section 2 includes descriptions of analytical and test equipment in several areas including thermodynamics, fluid flow, electronics, and materials testing.

Additional technical information on the articles in this Compilation can be requested by circling the appropriate number on the Reader Service Card included in this Compilation.

The latest patent information available at the final preparation of this Compilation is presented on the page following the last article in the text. For those innovations on which NASA has decided not to apply for a patent, a Patent Statement is not included. Potential users of items described herein should consult the cognizant organization for updated patent information at that time.

We appreciate comment by readers and welcome hearing about the relevance and utility of the information in this Compilation.

Jeffrey T. Hamilton, *Director*
Technology Utilization Office
National Aeronautics and Space Administration

NOTICE●This document was prepared under the sponsorship of the National Aeronautics and Space Administration. Neither the United States Government nor any person acting on behalf of the United States Government assumes any liability resulting from the use of the information contained in this document, or warrants that such use will be free from privately owned rights.

For sale by the National Technical Information Service, Springfield, Virginia 22161

Contents

	Page
SECTION 1. SPECTROMETERS AND RADIOMETERS	
Multiplate Focusing Collimator	1
Quick-Change Radiographic-Collimator Attachments	2
High Solar Intensity Radiometer	3
Self-Balancing Radiometer	4
A Liquid Radiation Detector With High Spatial Resolution	5
A Compton Scatter Attenuation Gamma Ray Spectrometer	6
Improved Position Resolution for X-Ray Detector	8
Carbon 14 Detection System	9
Ion Masking Improves Resolution in Quadrupole Mass Spectrometers	10
Magnetostrictively-Actuated Molecular Leak	11
Lightweight Cold-Cathode Ion Source Mass Spectrometer	12
A Survey of Mass Spectrometers	12
SECTION 2. ANALYTICAL AND TEST EQUIPMENT	
Traversing-Thermocouple Technique for Measuring the Thermal Conductivity of Materials Up to 1000° C	13
A Heat-Flow Calorimeter	14
Heating-Rate Sensor for Rapidly-Changing Heating Rates	15
Ductile-to-Brittle Transition Temperature Tester	16
Ion-Tracer Anemometer	17
Analytical Gas Trap	18
Sample Insertion Method for Continuous Electrophoresis Apparatus	20
Composite Fluid/Solid Flow-Measuring Device: A Concept	21
Leakage Indicator	22
Overvoltage/Undervoltage Transient Generator: A Concept	23
Cryogenic Liquid-Level Measurement and Control Unit	24
Digital Magnetic-Tape Skew Analyzer	24
Testing Electrostatic Properties of Dielectric Film	25
Angle-Versus-Torque Measuring System	26
Strap-Tension Meter	27
PATENT INFORMATION	28

Section 1. Spectrometers and Radiometers

MULTIPLATE FOCUSING COLLIMATOR

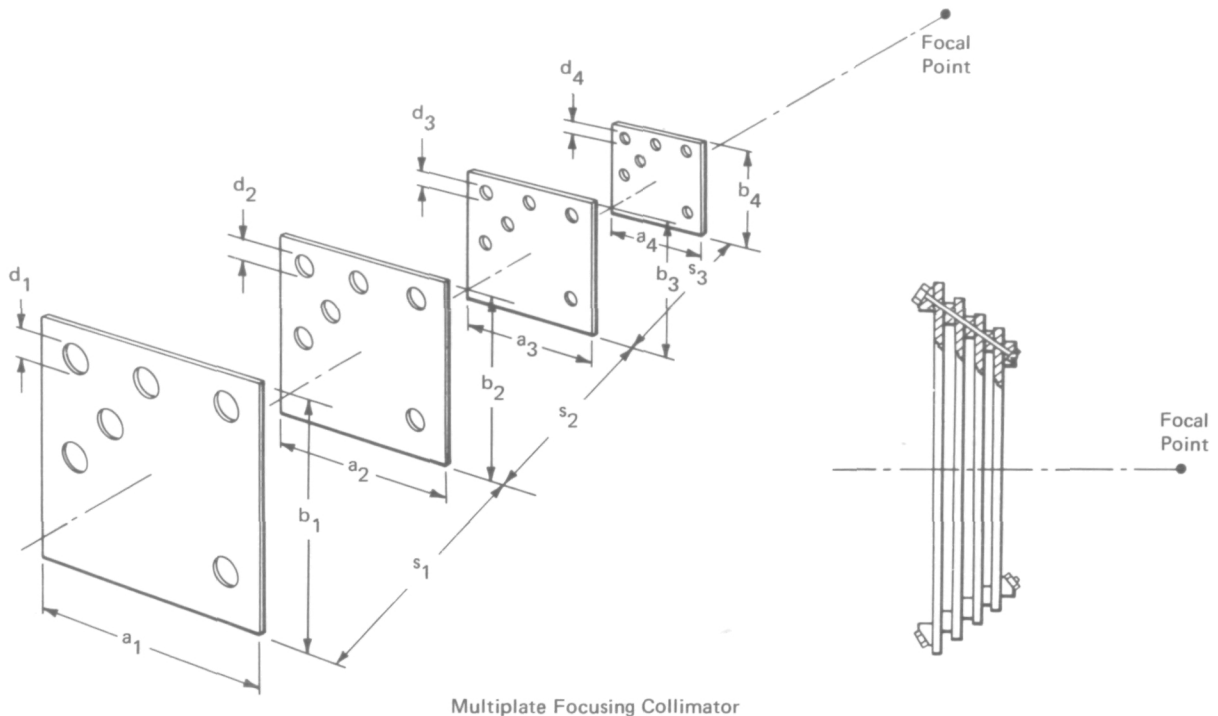

Multiplate Focusing Collimator

A collimator used to scan relatively-small near sources of radiation to obtain their energy distribution is illustrated in the figure. The collimator assembly is made of a number of plates alined in parallel planes and is interposed between a radiation source and a radiation detector.

Each plate (see figure) contains a number of apertures in a random distribution. All apertures on a given plate are the same size. The number and distribution of these apertures is the same on each of the plates, although the size of the apertures differs from plate to plate, in accordance with the size of the plate. The size of the plates (dimensions a and b), the size of the apertures in the plates (dimension d), and the spacing between the plates (dimension s) are precisely calculated to produce radiation channels that converge to a focal point. The radiation incident on the radiation detector is maximized when the focal point and the radiation source coincide.

The collimator is particularly useful in analyzing electromagnetic radiations, including high-energy X-rays, gamma rays, and particles. It produces an image consisting of an array of dots, corresponding to the apertures in the plates, and confined to the boundaries of the source. To obtain an accurate representation of the intensity distribution of the source, the collimator may be moved in a direction perpendicular to its optical axis. Details are available concerning the ratios leading to the determination of the focal point, possible methods of producing the apertures and the plates, and the use of a stepping motor in conjunction with the collimator to scan the source of radiation incrementally.

Source: R. B. Hoover and
J. H. Underwood
Marshall Space Flight Center
(MFS-20932)

Circle 1 on Reader Service Card.

QUICK-CHANGE RADIOGRAPHIC-COLLIMATOR ATTACHMENTS

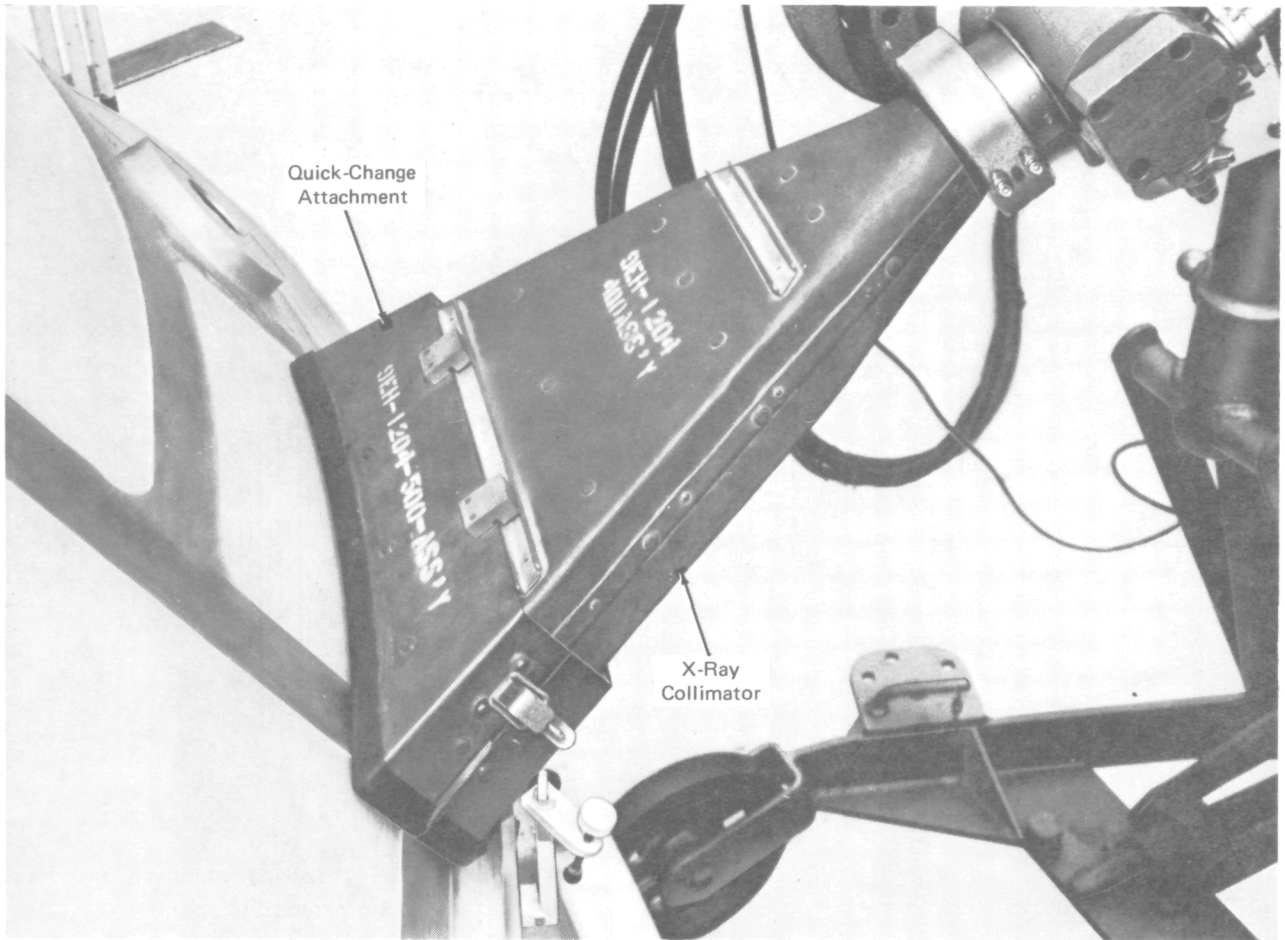

Radiographic-Collimator Attachment

An example of a quick-change collimator end attachment, which conforms to the surface contour and clearance requirements of a particular assembly to be radiographically inspected, is shown in the figure. Previously, X-ray collimators (beam shields) were designed and fabricated for each radiographic requirement. The split-half, quick-change end attachments save time and cost, as a single collimator can be used to inspect several assemblies. The collimators permit safe radiography in uncleared manufacturing areas.

Source: R. A. Marshall and F. E. Sugg of
Rockwell International Corp.
under contract to
Johnson Space Center
(MSC-17649)

Circle 2 on Reader Service Card.

HIGH SOLAR INTENSITY RADIOMETER

Silicon solar cells operated in a photoconductive mode can function as accurate, inexpensive, high solar intensity radiometers. Cells operated in this mode have been used to measure radiation intensities to 2800 mW/cm² (20 solar constants). Output is linear with intensity level, highly stable and reproducible. Response time is very fast. The device is small and rugged.

Silicon solar cells are frequently used to measure visible radiant energy. Generally, the cells are operated in the photovoltaic mode and the short circuit current is the measured variable used to correlate the radiation intensity level. Utilizing the solar cell in this manner requires the assumption that the short circuit current approximates the light generated current which is really the parameter that varies linearly with intensity level. This assumption is usually valid for intensity levels up to approximately 450 mW/cm² (3 solar constants). Above this level, the short circuit current is no longer linear with the intensity level due to internal resistance in the cells, high currents encountered, and surface temperature effects.

The linear operating range of silicon solar cell radiometers can be substantially extended by operating the cells in the photoconductive mode, rather than the photovoltaic mode. To achieve this, the cell is biased with a negative voltage of approximately one volt and

the circuit current measured. This current closely approximates the light-generated current and is directly proportional to the radiation intensity. Tests have established the linear relation of the cell current to the radiation intensity over the complete intensity range from 70 to 2800 mW/cm² (1/2 to 20 solar constants). Also, the cell current in the photoconductive mode is relatively insensitive to temperature changes.

In principle, silicon solar cells operated photoconductively would appear suitable for use as high-intensity solar radiometers for intensity levels much higher than 20 solar constants. Future investigations are planned for up to a 100 solar constant level.

The following documentation may be obtained from:

National Technical Information Service
Springfield, Virginia 22151
Single document price \$3.00
(or microfiche \$2.25)

Reference: NASA TMX-2412 (N72-10397) Silicon Solar Cell as a High-Solar-Intensity Radiometer

Source: J. R. Jack and E. W. Spisz
Lewis Research Center
(LEW-11533)

SELF-BALANCING RADIOMETER

The sensitivity and accuracy of a microwave radiometer depends strongly on the gain stability of its amplifier. Gain fluctuations have the same general characteristics as the measured signal, making separation of the two difficult. Several systems have been developed to reduce gain fluctuations. One of the better of these is the Dicke radiometer (Figure 1). The input signal is rapidly switched between the sensor and a constant temperature source. The output of the radiometer T_{out} , is as follows:

$$T_{out} = (T_a + T_e)G_a - (T_c + T_e)G_c \tag{1}$$

where T_a is the sensor temperature,
 T_e is the radiometer temperature,
 T_c is the comparison source temperature,
 G_a is the gain when T_a is sampled, and
 G_c is the gain when T_c is sampled.

In the conventional Dicke radiometer, gain modulation is used to make G_c equal to

$$G_a \frac{T_a + T_e}{T_c + T_e} \tag{2}$$

then, $T_{out} = G_a(T_a + T_e) - G_a(T_c + T_e) \frac{T_a + T_e}{T_c + T_e} = 0$ (3)

Thus at a constant source temperature, T_a , the output is independent of gain fluctuations; but as soon as the source temperature begins to change, this is no longer the case.

In the self-balancing radiometer (Figure 2) error-sensing and gain-control circuits provide feedback to adjust the gain automatically whenever changes in T_a make T_{out} not equal to zero. The output at the

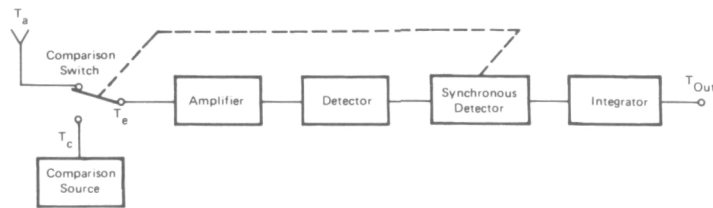

Figure 1. Dicke Radiometer

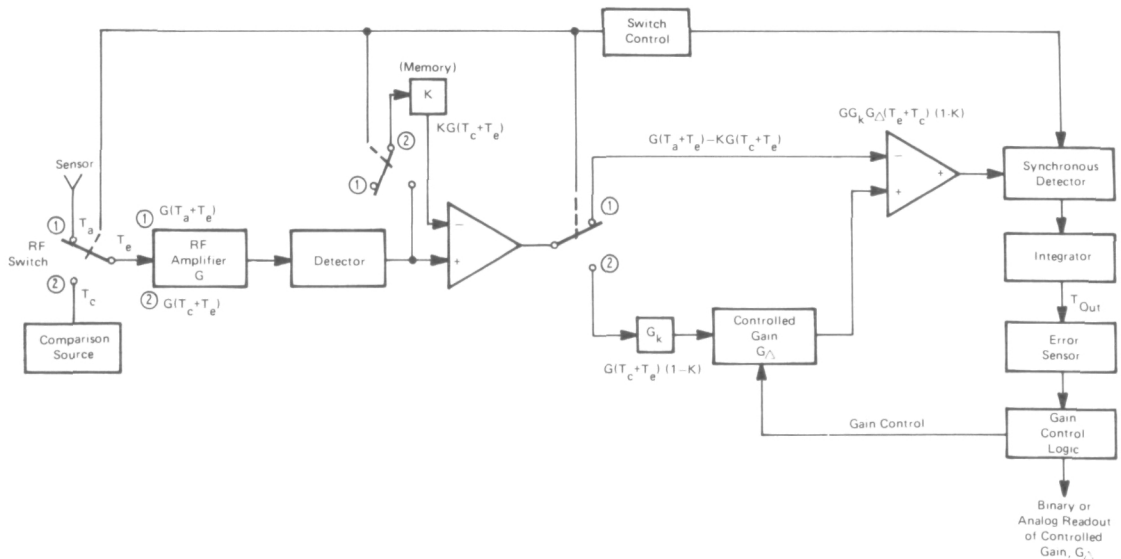

Figure 2. Self-Balancing Radiometer

detector, the same as in a conventional radiometer, is reduced by scaling factor, K , which determines the resolution. The comparison-signal gain adjustment, G_K , corresponds to the gain setting in 2 above. It makes the output zero (and independent of gain fluctuations) as long as the source temperature is unchanged. When a nonzero output is caused by changes in T_a , it is detected by the error sensor; and the controlled gain, G_{Δ} , is adjusted to return the output to zero, making the radiometer once again independent of gain fluctuations.

Since the value of G_{Δ} depends only on changes in T_a , the signal from the gain-control logic is related directly to the source temperature and is used as the radiometer output.

Source: S. Becker of
Cutler-Hammer Inc.
under contract to
Johnson Space Center
(MSC-14483)

Circle 3 on Reader Service Card.

A LIQUID RADIATION DETECTOR WITH HIGH SPATIAL RESOLUTION

A radiation detector using a liquid argon or xenon electron multiplication medium may improve spatial resolution an order of magnitude or more over the present 0.5 millimeter. The device operates in a manner similar to conventional gas-filled detectors, but by using a dense liquid medium, it promises to meet all present or expected resolution requirements.

Preliminary development, using a point anode, has proven successful. In addition to improving resolution over multiwire or position sensitive counters using charge division or rise-time, the point anode minimizes the problem of oblique tracks by permitting the construction of a very thin (one to five millimeter) counter.

Still in its early developmental stages, the system has some disadvantages. Maximum observed efficiency is currently 30 percent in liquid xenon, and 1 to 2 percent in liquid argon. This could pose a problem in some applications, particularly medical. Liquid argon requires

a cryogenic environment, and liquid xenon is expensive and would require elaborate recovery equipment.

Despite its limitations, the liquid medium system may prove to be a major development. In a two-dimensional configuration, it could be a superior imaging device for X-rays, providing high speed and improved resolution. The intended and most obvious application is for cosmic ray and high energy physics research. Other uses exist in the area of X-ray and neutron diffraction technology.

Source: L. Alvarez, et al.
University of California
under contract to
Johnson Space Center
(MSC-13965)

Circle 4 on Reader Service Card.

A COMPTON SCATTER ATTENUATION GAMMA RAY SPECTROMETER

A design has been proposed for a gamma ray spectrometer capable of gamma spectral measurements in radiation fields of 10^2 R/hr to 10^6 R/hr. Studies made on spectroscopy techniques and methods indicate that the Compton attenuation technique, utilizing semiconductor sum-Compton detectors, is the only practical method of performing gamma ray spectral measurements. The sum-Compton spectrometer consists of two or more separate detectors, with only the primary detector, designated detector A, exposed to the primary incident photon flux. The secondary detectors, designated detectors B,

are largely shielded from the incident photons but are in close proximity to detector A. Detector A is envisioned to be a small-diameter solid cylinder, and the radiation is incident on the end of this cylinder and collimation restricted to a diameter less than detector A diameter. Detector(s) B is a hollow cylindrical detector whose inside diameter is large enough to surround detector A.

Both detectors A and B for the sum-Compton configuration are dc-biased to approximately 500 volts through a resistance (not shown) to the bias supply. A

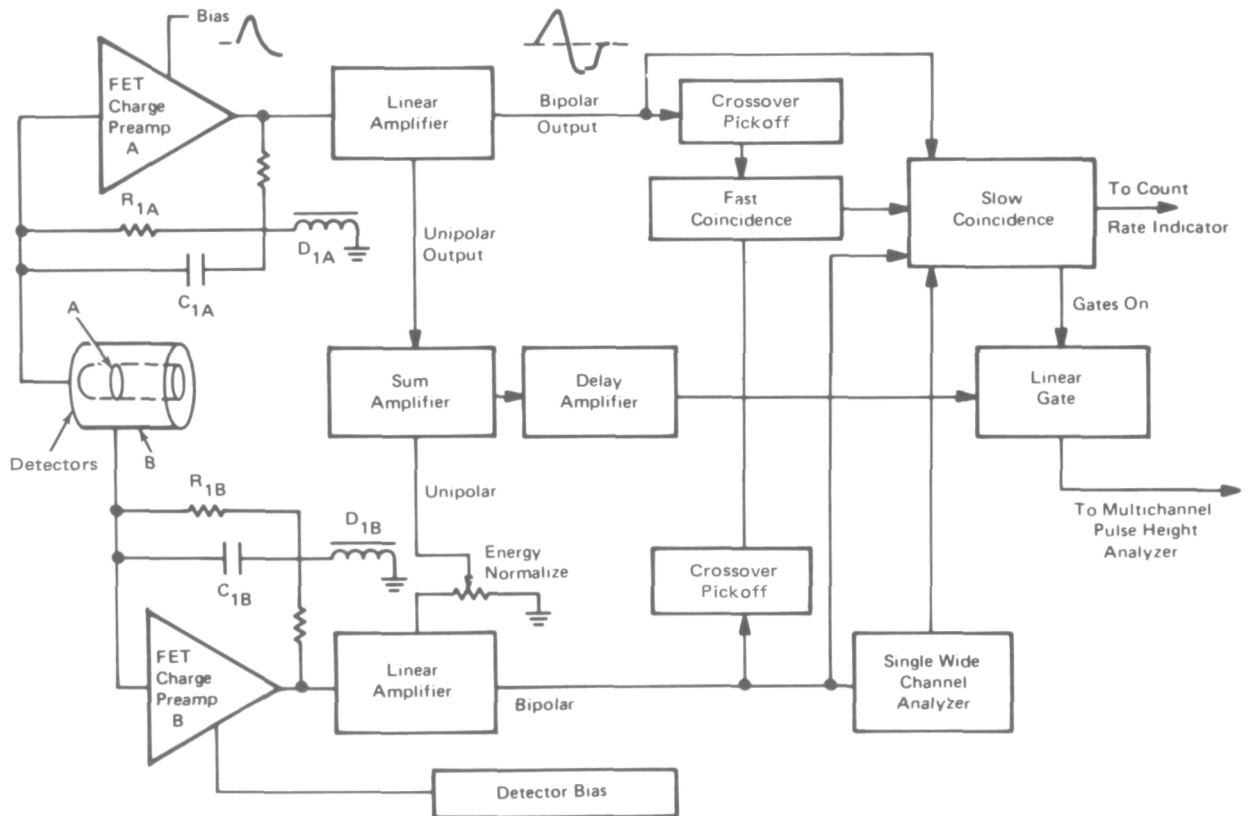

capacitor, also not shown, is used to ac-couple the FET charge sensitive preamplifier to the detector, and the detector to preamplifier distance should be as short as practical. The conventional feedback loop of the preamplifier is through R_1 and C_1 , and for good stability at high counting rates, the time constant, $T = R_1 C_1$, should be approximately 10^{-5} seconds.

Additional wave shape clipping is obtained from the reflected pulse from the shorted delay line D_1 . D_1 is not intended to provide a dc path to ground, and the reflected pulse should terminate in approximately 5×10^{-7} seconds after the pulse rise. This time interval is determined by the charge collection time for the detectors, which should approximate 2×10^{-7} seconds for the detector sizes under consideration. This delay line clipping is normally accomplished in the main linear amplifier, but is thought necessary for preamplifier stability at high count rates. Additional voltage and power gain, other than the charge to voltage conversion, will be provided in the preamplifier so that the linear amplifier may be located some distance away.

The linear amplifier is considered a standard delay line nonoverloading type, although the first delay line is incorporated in the preamplifier. The unipolar pulse is amplified in the first stage and routed to the sum amplifier. The later stage of the linear amplifier uses an identical delay line to D_1 to provide a bipolar output. Bipolar pulses are provided to a crossover pickoff for precise timing and fast coincidence timing.

The unipolar output of the detector B linear amplifier is gain adjustable so that differences in the electron-hole

pair creation energy of detectors A and B may be normalized. This is particularly necessary if the detectors are silicon and germanium. Such an adjustment is done in the laboratory, and once established for a given detector pair, should not be changed.

The sum amplifier adds the energy pulses from the two detectors. This sum is delayed and presented to the linear gate. The linear gate passes the summed pulse, provided all conditions of fast and slow coincidence are met.

A single channel analyzer is provided in the detector B chain of electronics. The scattered radiation has a particular energy band, which permits reduction of accidental coincidence signals. As an example for detector B, the low-energy spectrometer range should be 40 to 400 keV and that of the high-energy spectrometer, 150 to 500 keV.

The output of the linear gate consists of the summed energy pulses which are analyzed. The count rate from the slow coincidence circuitry may be used to determine the Compton target mass and to trigger the multichannel pulse height analyzer for accepting pulses from the linear gate.

Source: W. E. Austin of
General Electric Co.
under contract to
Marshall Space Flight Center
(MFS-21441)

Circle 5 on Reader Service Card.

IMPROVED POSITION RESOLUTION FOR X-RAY DETECTOR

An improved position-sensitive proportional counter allows the position of incident radiation to be determined more exactly than the spacing between the multiple sensors of the counter. This innovation is of particular importance for low-energy X-radiography, where a preamplifier is required for each sensor. The same resolution may be achieved with fewer sensors, thus requiring fewer preamplifiers.

The sensor for a position-sensitive radiation counter consists of an array of anode wires at a positive

potential with respect to an underlying orthogonal array of collector wires (see figure). The arrays are placed in a gas-filled radiation-proof housing with a radiation window. Radiation through the window results in an ion avalanche that is picked up by the collector wires; most of the avalanche is detected by a single collector, which corresponds to the position of the radiation source. The output of the array of collectors is passed to a tapped delay line, which transforms the simultaneous pulses to a series of sequential pulses that represent the energy distribution within the array.

The improved proportional counter integrates the output of the delay line and finds the time point in the pulse at which 50 percent of the energy has arrived. This point represents the centroid of the delay-line output and thus the position of the radiation source. The method of finding the centroid is shown in the figure.

The output of the integrator is fed into a delay line and an attenuator (set at one-half) and then to a comparator. When the undelayed and attenuated signal reaches the comparator, its output becomes positive. When the delayed but unattenuated signal reaches the comparator, its output becomes negative. The width of the comparator output pulse is a function of the position, in time, of the energy centroid of the output of the tapped delay line. This pulse locates the position of the radiation event to within at least one-tenth the spacing between the collector wires.

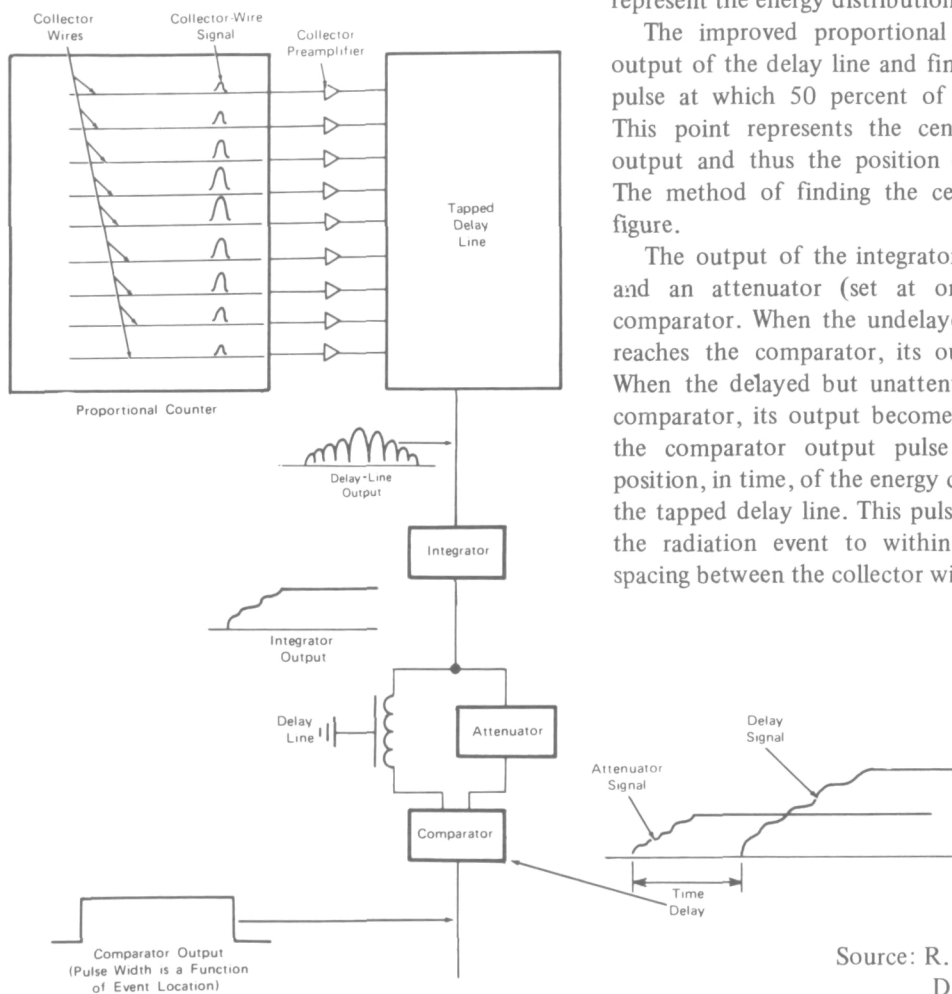

Source: R. Novick, M. C. Weisskopf,
D. Mitchell, and D. Held of
Columbia University
under contract to
Marshall Space Flight Center
(MFS-22805)

CARBON 14 DETECTION SYSTEM

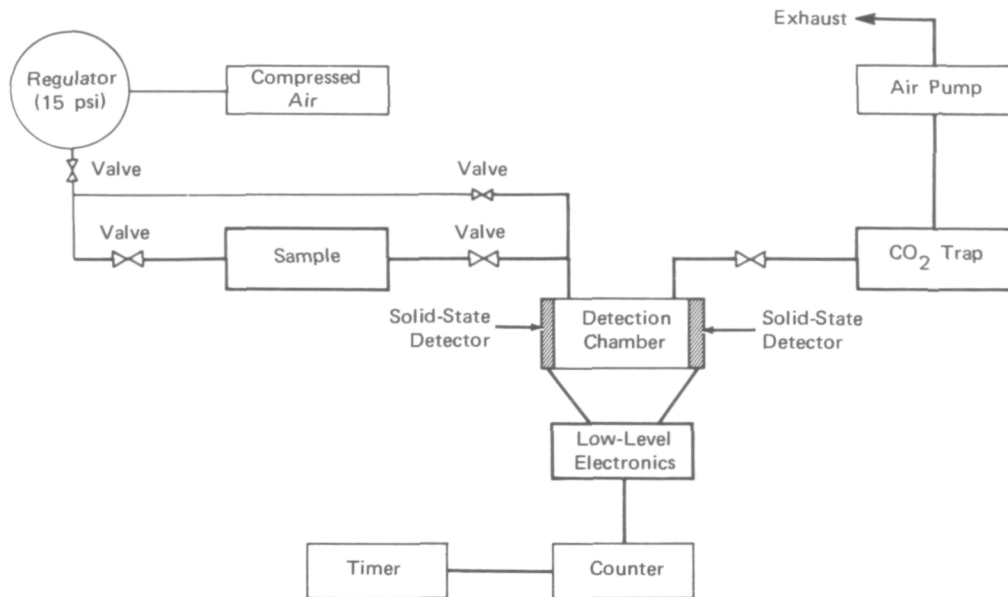

Schematic of Bacterial Growth Detection System

Carbon 14 presence has long been accepted as a reliable means for estimating the age of certain materials. It is now gaining acceptance as a means for nutrient labeling to determine the presence of biological and bacteriological activity. Scintillation counters or proportional counters are the standard devices for counting the beta particles emitted by C_{14} . However, such detection systems are elaborate, require considerable equipment, and consume large quantities of power.

A new simpler device incorporates diffused-junction solid-state silicon detectors in a guard-ring configuration as the beta-counting mechanism. The detectors make up the ends of a cylindrical detection chamber (see figure). Radioactive gas trapped in the enclosed volume is counted with at least 12 percent efficiency. The system has hybrid microcircuits which allow more than 50 percent of the C_{14} beta particles striking the sensors to be counted. This accounts for at least 50 percent of the decay taking place in the C_{14} within 2 hours.

The use of a solid-state sensor leads to a simple, reliable system operating at only 180 volts. The sensor will not be poisoned by its exposure to C_{14} , and hangup is minimized. It operates quite efficiently at room temperature, $28^{\circ}C$ ($82^{\circ}F$) although it becomes noisy at higher temperatures. At room temperature the noise level is less than 8.0 keV FWHM (full width at half maximum), which allows a low energy threshold (the accepted indicator of an efficient counter) of 32 keV. The counting electronics are conventional and may be packaged compactly. The performance of the overall system is more than adequate for most of the biological and bacteriological tests.

Source: Robert Earl Fortney of
TRW, Inc.
under subcontract to
Langley Research Center
(LAR-11438)

Circle 7 on Reader Service Card.

ION MASKING IMPROVES RESOLUTION IN QUADRUPOLE MASS SPECTROMETERS

A thorough experimental and computer-aided theoretical study has been made on the effects of ion masking in ion quadrupole mass spectrometry.

Mass spectrometers are used to analyze molecular composition by determining the mass-to-charge ratio (m/q) of ion fragments of the molecules. The spectrometer consists of three main parts: an ionization source to form ions from the sample, a separator to pick out ions with a specific mass/charge ratio, and an ion collector. In an ion quadrupole spectrometer, an electric quadrupole field is used to separate the desired ions.

The quadrupole field is formed by four parallel cylindrical rods on which an RF and dc potential are superimposed. The ions passing through the field oscillate. The RF/dc ratio is adjusted so that those ions of a given m/q ratio perform stable oscillations of a constant amplitude, while the remainder oscillate at increasing amplitudes and collide with the rods rather than reach the collector. However, several unstable ions do make it through the quadrupole filter and cause the m/q peaks to have significant "tails" that interfere with the resolution of the spectrometer. Parameters such as the frequency of the RF-field variation, the length of the quadrupole field, and the axial velocity of the ion can be adjusted to control the tails. But there are severe inherent limitations on the extent to which these parameters may be varied. To further improve the resolution, it is necessary to remove the unstable ions before they enter the quadrupole field.

In this study, new methods are developed for reducing peak tails. A mathematical analysis of the unstable ions shows that ions entering the quadrupole field near the X and Y axes (where the Z axis is in the direction of ion travel) will not be deflected by the rods. Computer simulation of the unstable ion behavior indicated that placing a cross-shaped mask over the entrance to the quadrupole field would reduce the magnitude of the tails. Based on these results, 0.005 and 0.003 inch cross masks were used with an actual spectrometer. The results were extremely good.

Resolving powers over 750 were obtained, though they required a modification of the nozzle to maintain sensitivity. In the past, resolutions of only 200 were not uncommon with this system. For instance, the accompanying illustration shows how the peaks for CO_2^+ and C_3H_8^+ can be resolved with this technique, a result that is not possible with this instrument without ion masking. It is also indicated that the use of angle masking may improve even these results.

The study itself adds significantly to the quantitative understanding of the quadrupole mass filter. It includes development of a quantitative theory of ion oscillations, a computer analysis of ion behavior, and the identification of the determining factors in peak tail size.

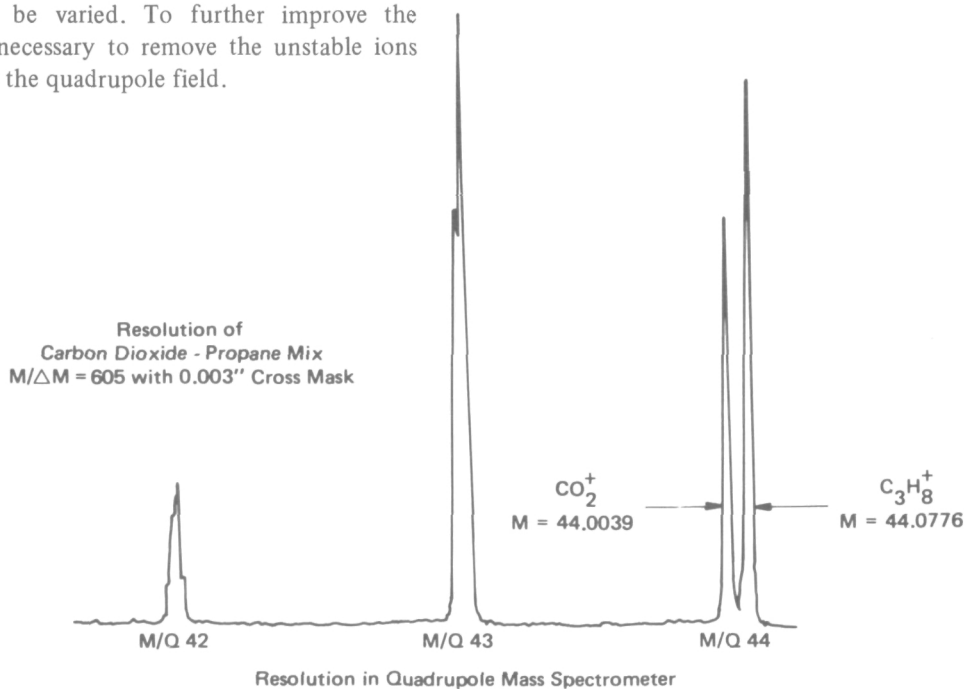

The following documentation may be obtained from:
 National Technical Information Service
 Springfield, Virginia 22151
 Single document price \$3.00
 (or microfiche \$2.25)
 Reference: NASA CR-11578 (N71-13676), Quadru-
 pole Ion Entrance Mask Study

Source: N. Ierokomos and M. R. Ruecker of
 Perkin-Elmer Corp.
 under contract to
 Goddard Space Flight Center
 (GSC-11406)

MAGNETOSTRICTIVELY-ACTUATED MOLECULAR LEAK

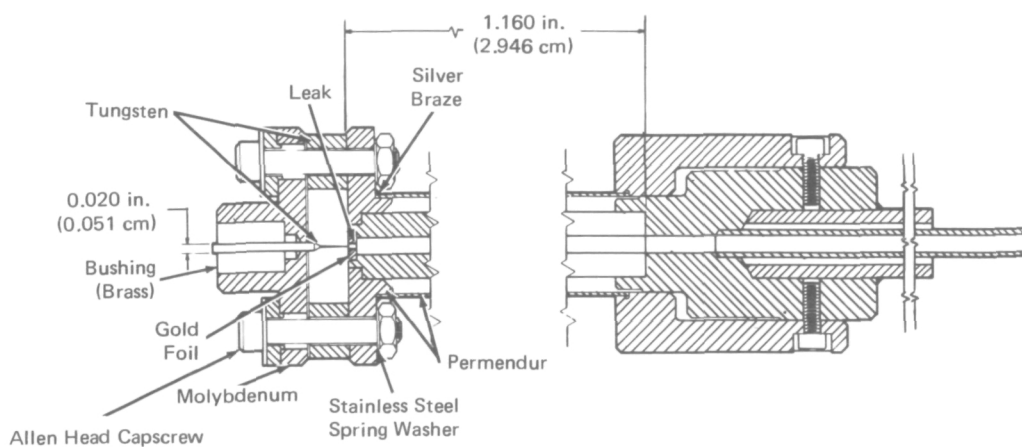

Magnetostrictively-Activated Molecular Leak

Because the ion source of a mass spectrometer operates at pressures near $1.33 \times 10^{-3} \text{ N/m}^2$ (10^{-5} Torr), the input of gas must be of molecular order [i.e., at pressures near 10^{-4} N/m^2 (10^{-6} Torr)]. In addition the leak-source must respond rapidly to changes in inlet-gas composition and in leak rate, in response to a control signal.

A controlled leak system has been developed to meet these requirements. It consists of a tungsten needle inserted through a 0.051-mm (0.002-in.) thickness of gold foil. When the needle is withdrawn by about $1.27 \mu\text{m}$ (0.00005 in.), gas can leak through the small space left between the needle and the foil. The leak can thus be opened and closed and the leak rate varied by moving the needle with respect to the foil.

Needle motion is generated by the magnetostrictive action produced in nickel and permendur when they are placed in a magnetic field. When no field is present, a mechanical preload forces the needle assembly against

stops on the foil assembly so that it is inserted fully into the foil, closing the leak without rupture. The application of current to the coil causes the needle to move outward, opening the leak.

Details are available concerning construction and operating characteristics. The device can be used as a valve on a gas multiplexer or as a fixed input leak with only manual adjustment, and it may be of interest to laboratories involved in the studies of gaseous impurity effects.

Source: W. Brubaker, J. H. Marshall III,
 and E. T. Parker of
 Analog Technology Corp.
 under contract to
 Johnson Space Center
 (MSC-14171)

Circle 8 on Reader Service Card.

LIGHTWEIGHT COLD-CATHODE ION SOURCE MASS SPECTROMETER

A complete cold-cathode quadrupole mass spectrometer system has been constructed as a flight prototype. The spectrometer and associated electronics are packaged as a single unit weighing approximately 2.2 kg (4 lb 13 oz). The system operates from a 28-Vdc source at an average power of 5.25 W with a mass range of 1 to 50 amu and a resolution of 1 amu in the pressure range from 10^{-8} to 10^{-4} torr. The mass range may be scanned in as little as five seconds if required.

Improvements to the spectrometer tube include modification of the entrance port; rearrangement of the electrical feedthroughs for easier mounting; and relocation of the electron multiplier, closer to the exit aperture, to improve ion collection at the first dynode.

The electronics of the system are also improved in several ways. Three discrete-component amplifiers are replaced by integrated-circuit operational amplifiers and a dc voltage booster. Further refinements are made to the voltage regulator and to the starting circuit for the switching transistors.

Source: Jonathan R. Roehrig of
Norton Research Corp.
under contract to
Langley Research Center
(LAR-10727)

Circle 9 on Reader Service Card.

A SURVEY OF MASS SPECTROMETERS

Mass spectrometers are used for the analysis of ionized matter in a gaseous state according to its mass-to-charge ratio (m/q). There are many types of mass spectrometers with a wide variety of applications. Consequently, no one instrument is suitable for all uses.

With the increasingly broad applications of mass spectrometry, a need has developed for a consolidated survey of the essential characteristics and features of the various instruments and techniques. Such information has been collected and consolidated in an available report; included are (a) general descriptions of techniques, (b) features of instruments, and (c) a summary of pertinent advantages and disadvantages. With this information, the user should be able to select the most appropriate instrument more efficiently.

The principal difference between the various types of mass spectrometers lies in the analyzer section used for separating ions. In this report, the individual characteristics of different types of analyzers are examined. These analyzers include the following types: magnetic, time-off-flight, radio frequency (Bennett tube), omegatron, farvitron, quadrupole, monopole, and three-dimensional quadrupole (ion cage analyzer).

Source: W. Moore, Jr., and
P. W. Tashbar of
Marshall Space Flight Center
(MFS-22920)

Circle 10 on Reader Service Card.

Section 2. Analytical and Test Equipment

TRAVERSING-THERMOCOUPLE TECHNIQUE FOR MEASURING THE THERMAL CONDUCTIVITY OF MATERIALS UP TO 1000° C

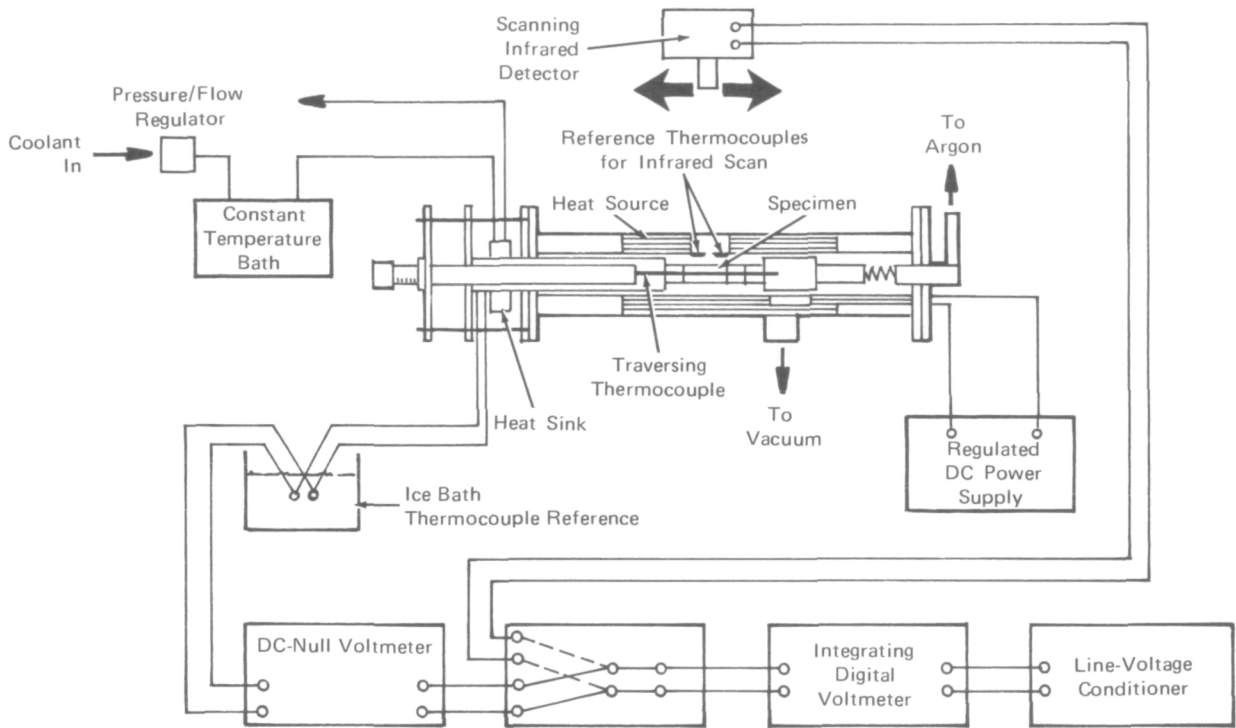

Schematic of Traversing-Thermocouple, Thermal Conductivity Measurement Technique

A traversing-thermocouple, thermal conductivity apparatus (see figure) has been developed for measuring the thermal conductivity of semiconductor (especially thermoelectric) materials. A cylindrical specimen with an axial hole, interposed between a heat source and a heat sink, is used in the system. An ultrafine sheathed thermocouple, 0.13 cm (0.05 in.) in diameter, traverses the interior of the specimen and the enclosing quartz tube (passive thermal guard). Mapped temperature profiles are then analyzed to determine the thermal conductivity of the specimen. A procedure for the calibration of this apparatus has also been developed which allows the measurement of 20 individual data points in the range 50° to 450° C (122° to 842° F) to be made in less than 4 hours. The measurement must be preceded by a 6 to 8 hour period of thermal stabilization.

The apparatus and procedures are designed to accommodate specimens of the same size as the elements

used in conventional direct energy conversion devices: 0.5 to 1.0 cm (0.2 to 0.4 in.) in diameter by 1.5 to 2.3 cm (0.6 to 0.9 in.) in length. The specimens are subjected to a temperature gradient of 250° to 550° C (482° to 1022° F) over their length; these conditions closely approximate the operational gradients in thermoelectric devices. Specimens examined to date consist of thermoelectric materials such as PbTe, Bi₂Te₃, PbSnTe, and SiGe. Other families of materials (such as metals, insulators, and semi-insulators) have not yet been examined.

Source: P. E. Eggers of
Battelle Memorial Institute
under contract to
Goddard Space Flight Center
(GSC-10908)

Circle 11 on Reader Service Card.

A HEAT-FLOW CALORIMETER

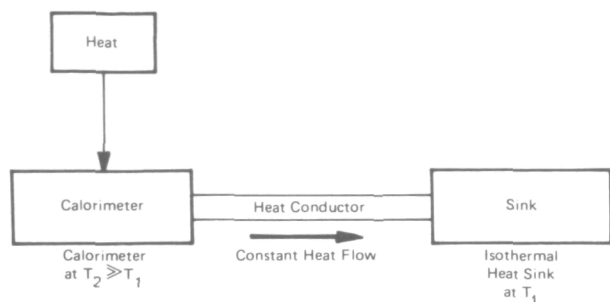

Figure 1. Schematic of Heat-Flow Calorimeter

Nickel-cadmium cells are used in place of more conventional lead storage batteries when greater capacity/weight ratios are needed. The reaction mechanism for the nickel-cadmium cell is not known well enough, however, to allow calculation of heat effects. Therefore, these must be determined with a calorimeter. Conventional calorimeters cannot be used because these cells generate more heat than can be held in the calorimeter.

A heat-flow calorimeter has been developed to measure the heat absorbed or evolved in a cell. It determines the amount of external heat that must be supplied to the calorimeter to maintain a constant flow to an isothermal heat sink. The calorimeter consists of a thermally isolated calorimeter vessel with a path for heat conduction to a heat sink. The heat sink is held at a constant temperature that is considerably lower than the calorimeter temperature. Figure 1 depicts the way in which the calorimeter works.

A heater winding in the calorimeter (near the junction with the conductor) has enough power to keep the calorimeter at a constant temperature. Thus, the flow-rate between the calorimeter and the heat sink is constant. A change in the amount of heat being generated inside the calorimeter will require a change in the amount of electric power needed by the heater to maintain a constant temperature.

In a steady state, the total heat (W_T) required to maintain the calorimeter at a temperature T_2 will be equal to the amount of heat passing to the heat sink.

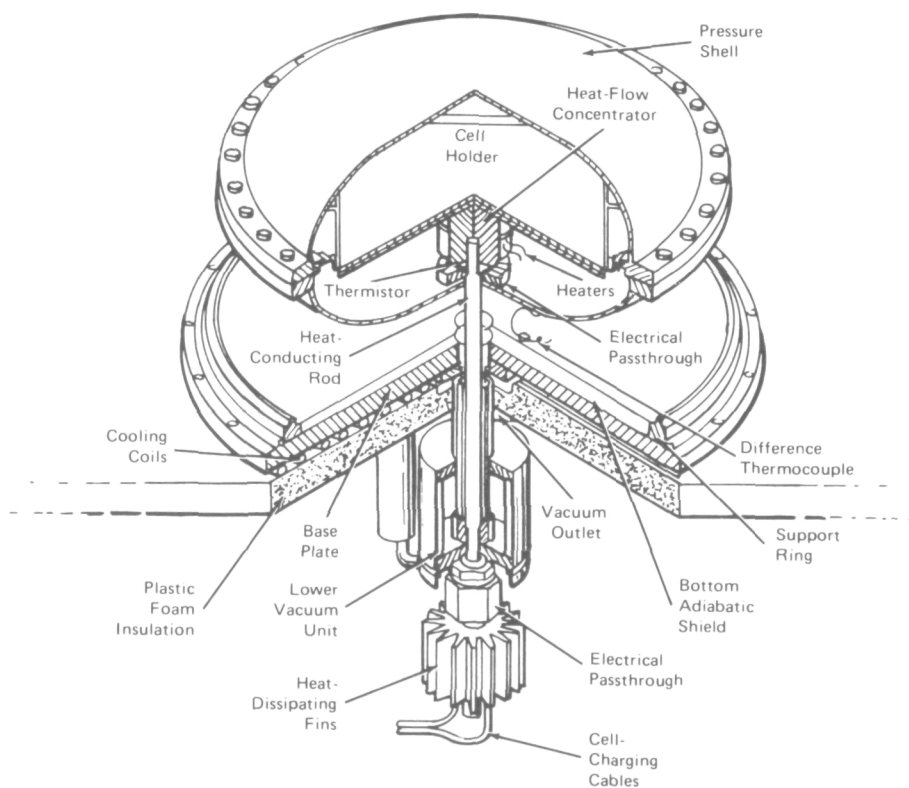

Figure 2. Quarter-Section Drawing of Calorimeter

This heat will be from several sources: W_E , W_B , W_L , and W_C where $W_T = W_E + W_B + W_L + W_C$, and

W_E = heat added electrically to maintain a constant T_2 ,

W_B = heat generated (or absorbed) by the cell,

W_L = heat loss to the surroundings,

W_C = heat introduced by an optional calorimeter heater, and W_L , the heat loss, need not be known as long as it is constant.

Since W_T is constant, any change in W_B , heat evolved, must be reflected in a change in W_E .

Figure 2 is a view of a practical heat-flow calorimeter. The heat sink can be a liquid kept at its boiling point. In this way, any heat added to the heat sink will be used as heat of vaporization and will not change the temperature. This calorimeter will measure a heat flow of 30 watts to within 0.01 watts and can handle current flows through the calorimeter of up to 50 amperes.

Source: William V. Johnston of
Rockwell International Corp.
under contract to
Goddard Space Flight Center
(GSC-11434)

Circle 12 on Reader Service Card.

HEATING-RATE SENSOR FOR RAPIDLY-CHANGING HEATING RATES

Rapidly-changing heating-rate data are not sensed accurately as a function of time when a slow-responding heating-rate sensor is employed. A faster responding heating-rate sensor has been developed. It consists of two metal plates separated by a spacer that serves as a conductive heat-resistant path having the thermal resistance required by the particular design. Thin thermocouple wire is attached to both the outer and inner plates, to sense plate temperatures and/or differential temperatures between plates.

The unit is fastened at its periphery to the side of a surface that will be subjected to a varying heating-rate input. The thermocouple leads are connected to a suitable recording device that may be at a considerable distance from the heating-rate sensor. When subjected to a heat flux, the exposed plate rises in temperature at a rate determined by the heat-flux level, its heat capacity, the value of the thermal resistance between the outer and inner plates, and the inner-plate heat capacity. The differential temperature between the outer and inner plates is found to be directly proportional to

the applied heat-flux levels. A small phase lag exists, which may be determined by calibration or by analyzing the difference between the applied variable heat flux and the differential plate-temperature response.

The new heating-rate sensor can accurately measure rapidly-changing heat-flux levels [of about 1.13×10^6 $W/m^2 s^2$ (100 BTU/ft²s²) in the range of 600 to 400,000 W/m^2 (0.05 to 35 BTU/ft²s)]. The sensors can be made in a conventional machine shop; they can be made quite thin and thus will not significantly influence boundary-layer characteristics when employed for aerodynamic heating-rate determinations.

Source: Edward W. Schwartz of
General Dynamics
under subcontract to
Langley Research Center
(LAR-11380)

Circle 13 on Reader Service Card.

DUCTILE-TO-BRITTLE TRANSITION TEMPERATURE TESTER

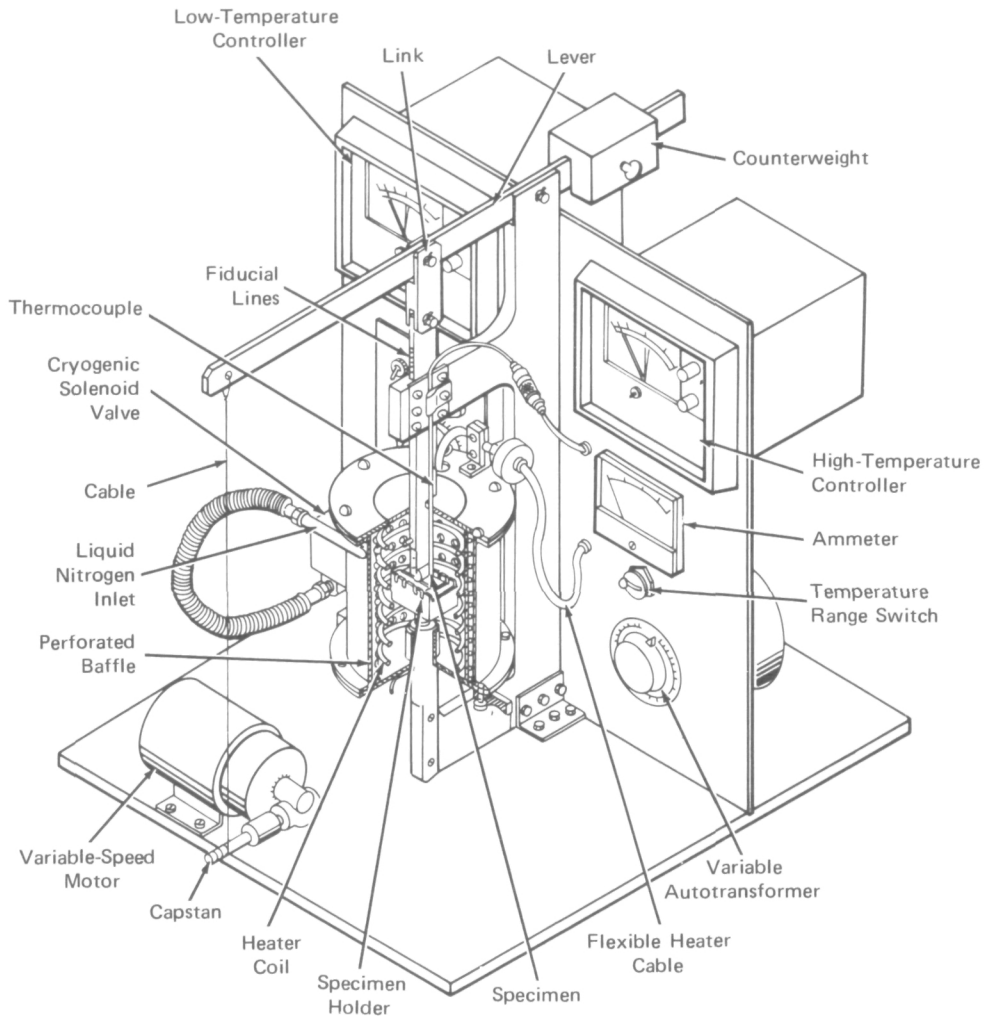

Ductile-to-Brittle Transition Temperature Tester Assembly

A bend tester to determine the ductile-to-brittle transition temperature (DBTT) of body-centered-cubic metals and alloys has been designed, built, and satisfactorily operated. The tester incorporates a single test chamber for cooling or heating test specimens. Ordinarily tests can be carried out at temperatures from 81 to 923 K (-314° to 1200° F); however, the tester can easily be modified for use at temperatures up to about 1273 K (1832° F). Additional features of the tester include specimen-aligning support rollers and the choice of either motorized or manual operation.

The assembly of the DBTT tester is shown in the figure. Overall dimensions are 48.3 cm (19 in.) wide by 56 cm (22 in.) high by 53.3 cm (21 in.) deep. Temperatures from 81 K to room temperatures are obtained by cooling the test chamber with liquid nitrogen. Temperature control in this low-temperature range is obtained by means of a solenoid valve in the liquid nitrogen supply line actuated by a temperature controller. Temperatures from room-temperature to 923 K are obtained by heating the test chamber with a resistance heating unit. Temperature control in this range is obtained by means of a power relay operated by a temperature controller.

The test chamber can be lowered for positioning test specimens in the specimen holder. Broken specimens may be removed in the same way. A load can be applied to bend a specimen by means of a slide actuated through a lever either manually or with a variable speed motor. The apparatus can also be used for determining the minimum bend radius of sheet metals as a function of temperature, and it can be used for testing readily oxidizable metals and alloys by the simple expedient of purging the chamber with inert gas through the liquid nitrogen inlet line.

The following documentation may be obtained from:

National Technical Information Service
Springfield, Virginia 22151
Single document price \$3.00
(or microfiche \$2.25)

Reference: NASA TM-X-2853 (N73-27452), A Simplified Ductile-Brittle Transition Temperature Tester

Source: Alan Arias
Lewis Research Center
(LEW-12074)

ION-TRACER ANEMOMETER

An anemometer capable of measuring gas velocities in the range of zero to 0.45 m/s (0 to 1.5 f/s) has been built and tested. It operates by emitting an ion into the gas stream and detecting it with a probe downstream. By knowing the time between emission and probe response, and the distance between the two points, the velocity of the stream may be determined.

It has not previously been possible to measure such low flow rates. To achieve this, the anemometer incorporates several novel features:

a. The use of an electrical field to superimpose a drift velocity onto the flow velocity so that travel time can be reduced, minimizing ion-diffusion effects and providing a zero-velocity reference signal;

- b. The use of a reference head identical to the measuring head, but shielded from gas flow, to provide a zero-flow reference time base;
- c. An output independent of drift velocity;
- d. A cylindrical sensing configuration to provide measurement capabilities in any direction perpendicular to the instrument handle.

Source: R. L. Bass III of
Southwest Research Institute
under contract to
Marshall Space Flight Center
(MFS-22534)

Circle 14 on Reader Service Card.

ANALYTICAL GAS TRAP

The stainless steel gas trap design illustrated in Figure 1 provides good thermal conduction in a cryogenic environment and is capable of confining a large volume of carrier gas, containing some small percentage of volatile contaminants, at cryogenic temperatures. The size of this volume of gas effectively determines the

limits of detection in a gas-chromatographic mass-per-volume analysis. Stainless steel construction also permits thorough chemical cleaning followed by a high-temperature bakeout at 249°C (480°F), yielding a negligible level of retained contamination.

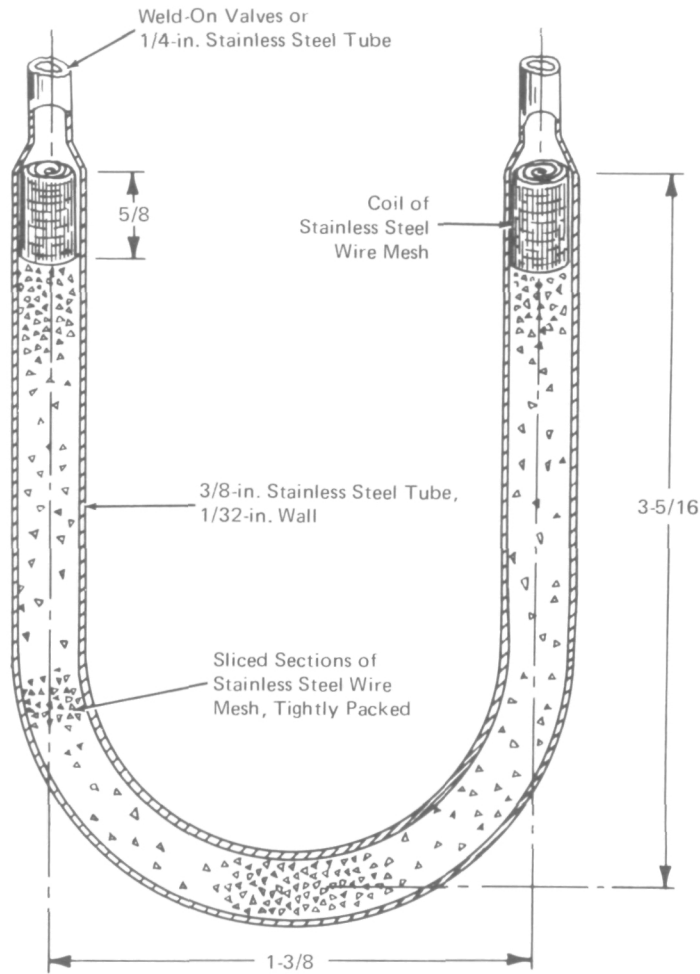

Note: All dimensions are in inches

Figure 1. Analytical Trap

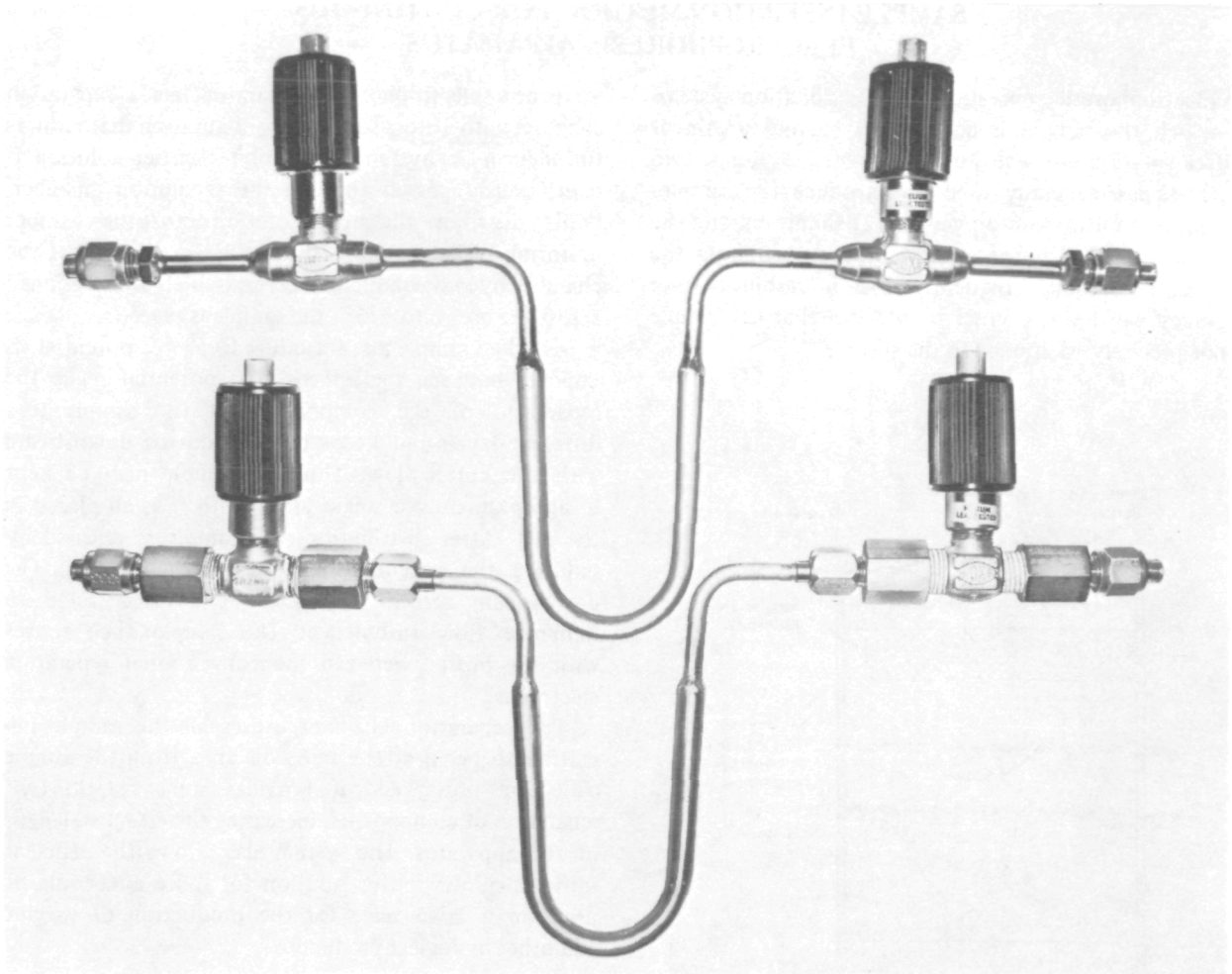

Figure 2. Analytical Trap Valve Configurations

The apparatus consists of a stainless steel (type 316) U-tube nearly filled with a matrix of sliced sections of stainless steel mesh. Small coils of mesh fill the volume remaining at each end of the tube. Vacuum sampling valves may be attached to each end of the tube in various configurations (Figure 2). The trap should be useful in precision analyses using molecular-sieve gas-chromatography equipment.

Source: E. W. Ceroky and
R. M. Cuthbertson of
Dynalectron Corp.
under contract to
Johnson Space Center
(MSC-14462)

No further documentation is available.

SAMPLE INSERTION METHOD FOR CONTINUOUS ELECTROPHORESIS APPARATUS

Electrophoretic separation and fractionation systems in which the sample is added to a moving stream of buffer solution are well known. In these systems, two methods are generally used to introduce the sample: (1) prior implantation on gels or (2) simply mixing the sample with the buffer at a point upstream from the area of separation. Frequently, loss in resolution and accuracy can be attributed to the fact that the sample is not precisely positioned in the system.

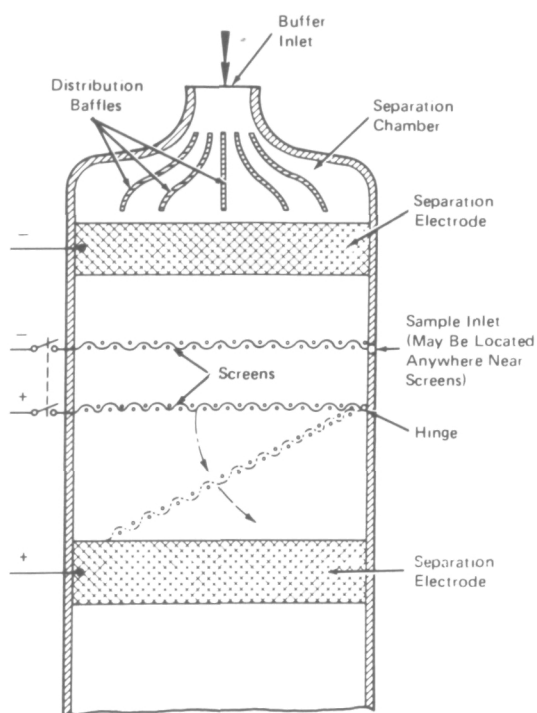

Electrophoretic Separation System

A new electrophoretic apparatus has a separation chamber with a cross-sectional configuration that reduces turbulence. A buffered electrolyte carrier solution is continuously passed through the separation chamber; baffles distribute the buffer solution across the chamber uniformly. The sample is distributed evenly across the chamber by two conductive screens, which are positioned across the area into which the sample is placed.

As the sample is introduced, a dc potential is imposed between the screens. The potential begins the separation of the components of the sample into different layers but keeps it from moving downstream with the buffer flow. Thus the sample may be kept in approximately a single plane until it is all placed in the cell. After distribution, the sample is released by reducing the potential imposed on the screens. The downstream screen may also be pivoted aside to minimize flow turbulence. The sample then moves with the buffer, between the conventional separation electrodes.

The separation chamber causes all the sample migration to begin at the same distance from the sample collection ports; and it provides some "stationary" separation of components, increasing the effective length of the apparatus. The system also allows the efficient retrieval of the buffer solution for reuse and could be used on a large scale for the production of vaccine and other biological products.

Source: L. R. McCreight of
General Electric Co.
under contract to
Marshall Space Flight Center
(MFS-21395)

Circle 15 on Reader Service Card.

COMPOSITE FLUID/SOLID FLOW-MEASURING DEVICE: A CONCEPT

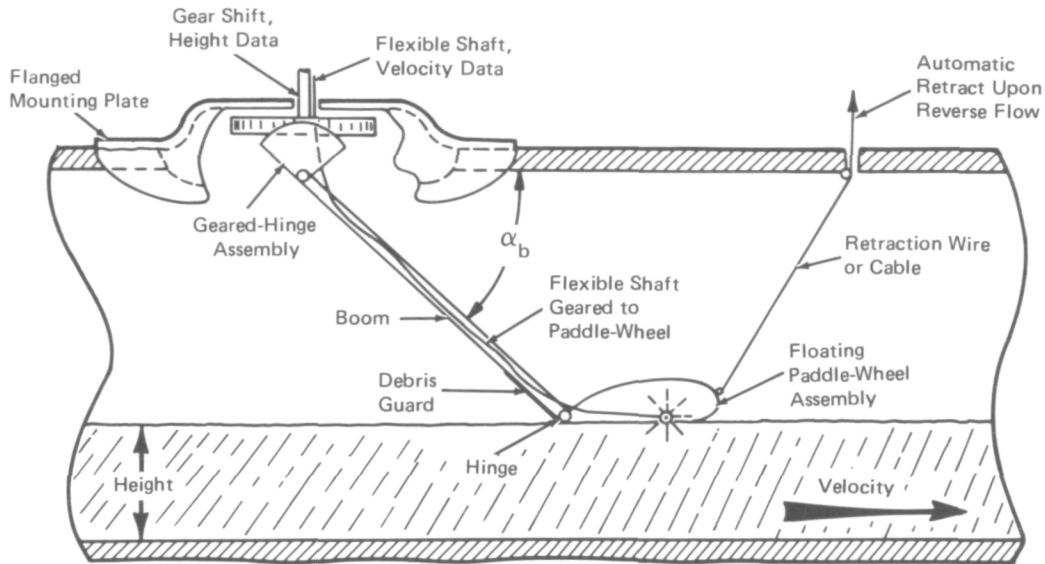

Fluid/Solid Flow-Measuring Device

The device shown in the figure can be used to measure fluid flow when the presence of solids in the fluid makes it impossible to use conventional flow meters. The device is durable, resists corrosion, and can be used in several sizes and types of pipes. It can be used to monitor fluid flow, industrial waste flow, or as part of a flow measurement system in industrial processes.

The rate of rotation of the paddle wheel, measured at the top end of the flexible shaft geared to it, gives the flow velocity, V . The boom angle, α_b , can be used to find the liquid height, H , which determines the cross-sectional area of the fluid. This information can then be used to determine the volumetric flow rate F_v .

The presence of solids in the fluid may temporarily interrupt the measurement, but will not significantly interfere with the device. Large floating solids will

merely lift the floating paddle-wheel assembly and pass under it. If reverse flow is anticipated, a reverse-flow alarm and an automatic-retraction system could be installed. The automatic retraction system could also be used to free trapped solids that might interfere with the device. A second assembly could also be installed at an angle of 180° to the one shown in the figure, dropping onto the fluid surface automatically as the first is retracted upon flow reversal.

Source: F. D. Evans, Jr.
Kennedy Space Center
(KSC-10653)

No further documentation is available.

LEAKAGE INDICATOR

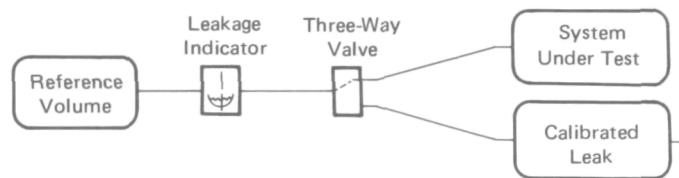
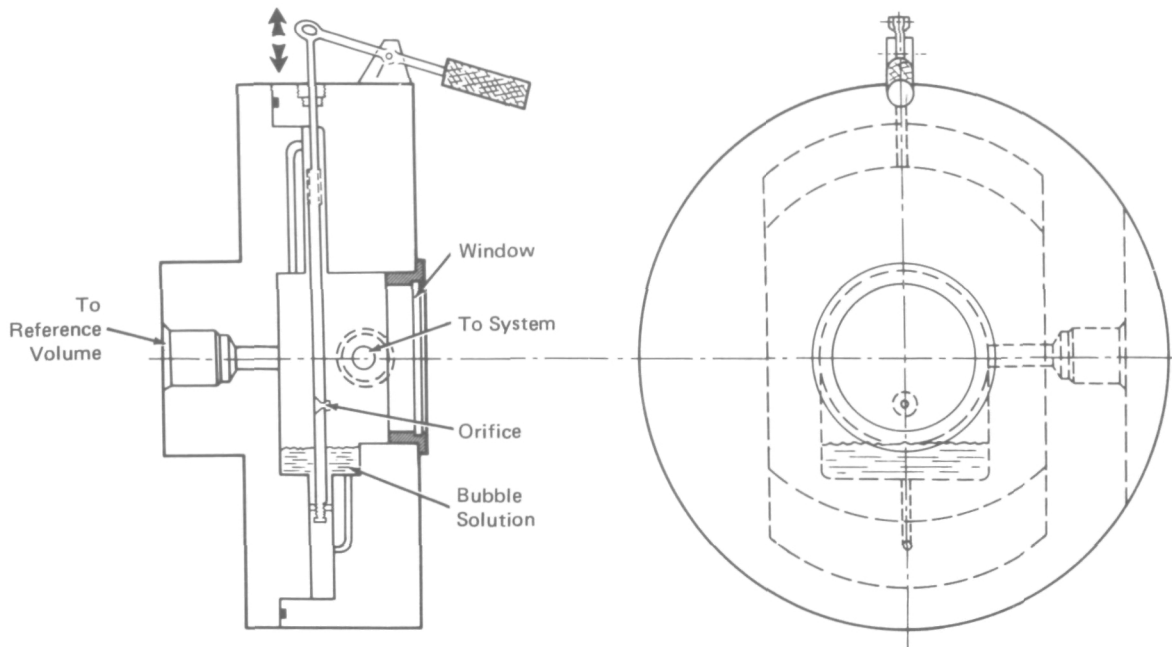

Leakage Indicator

The rate of gas leakage from a closed system may be determined by placing a single-orifice leakage indicator (see figure) between the system and a reference volume. The orifice, which passes through a movable plate, is dipped into a small reservoir of bubble solution with the handle at the top of the indicator. The plate has a gasket seal on both sides to prevent leakage from the reference volume to the system by any path other than through the orifice. This procedure places a bubble film over the orifice, and any film deflections may be observed through a window.

The indicator can be calibrated to determine effective leak rates versus deflection of the bubble film over a known period of time. The calibrated leak may be a small-diameter capillary tube with a pressure differential across it. The leak rate is varied by varying the pressure differential. The calibrated leak is adjusted until the

flow at the orifice appears identical for both the calibrated leak and the system under test. The orifice size, the pressure differential, and the reference volume can be varied to provide different leakage rates.

Manufacturers and designers of flow-measuring instruments and differential-pressure indicators may be interested in this device. It may also be useful in leak-checking refrigeration or other fluid systems.

Source: R. Y. Boerner of
McDonnell Douglas Corp.
under contract to
Marshall Space Flight Center
(MFS-20923)

Circle 16 on Reader Service Card.

OVERVOLTAGE/UNDERVOLTAGE TRANSIENT GENERATOR: A CONCEPT

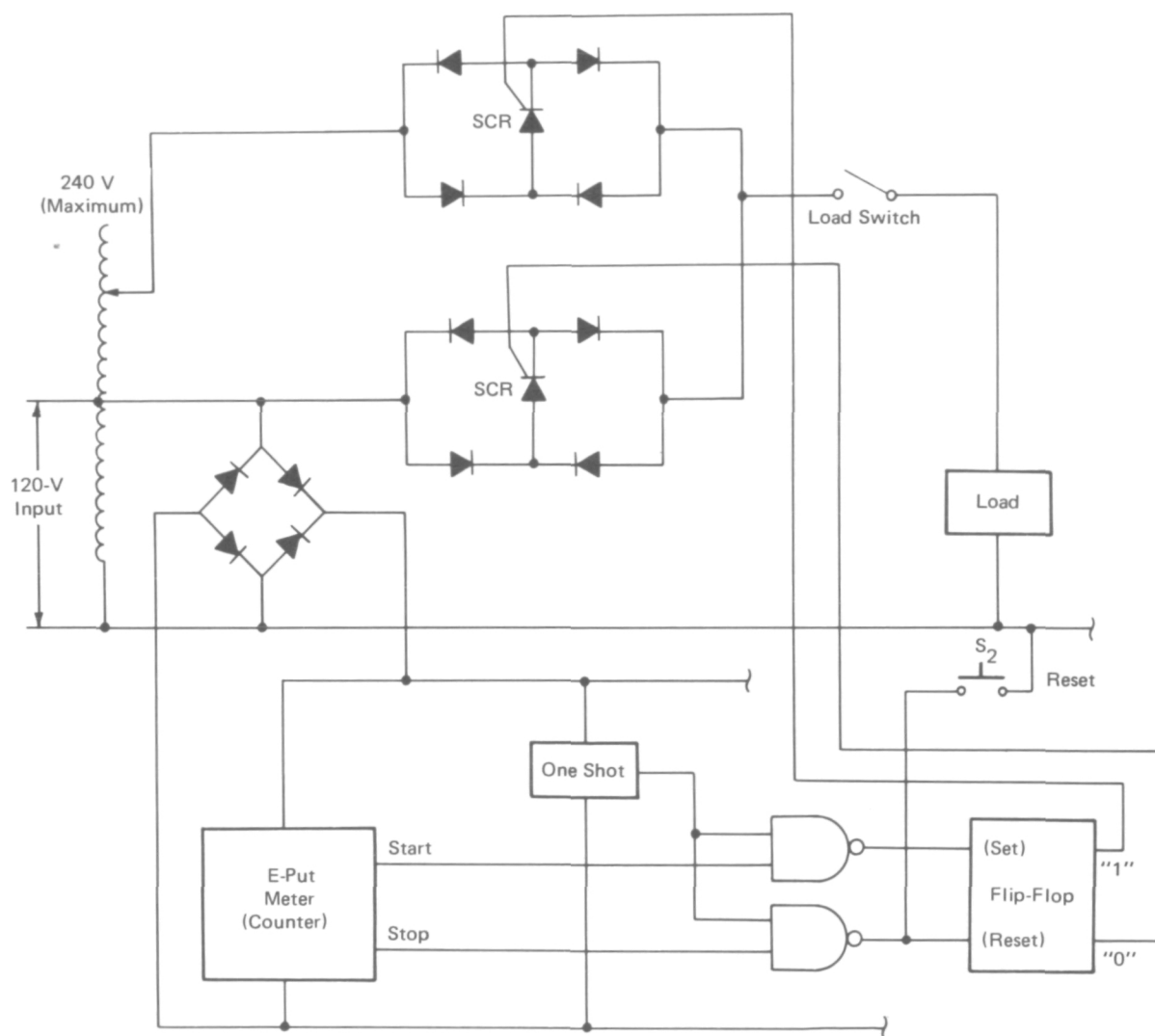

Overvoltage/Undervoltage Transient Generator

The circuit shown in the figure produces overvoltage and undervoltage transients (spikes) on a nominal 120-Vac line. Transient magnitudes are selectable from zero to 240 V, and time intervals from 8.3 ms to several seconds, in 8.3-ms steps. The circuit may be used for testing undervoltage detectors, overvoltage detectors, and circuits or equipment in which such detectors are used. Systems or equipment installations also may be tested for susceptibility to powerline instability.

The circuit incorporates two novel features: (1) the use of dual bridges with simultaneous gate control to switch between two different voltages from one source, in order to provide voltages for system testing, and (2)

the use of a synchronized pulse to provide for the switching of ac voltages at zero level. The second feature provides for changes in the magnitude of the sine wave in a continuous waveform, without spikes or interruptions.

Source: L. S. Wright of
Rockwell International Corp.
under contract to
Johnson Space Center
(MSC-17997)

Circle 17 on Reader Service Card.

CRYOGENIC LIQUID-LEVEL MEASUREMENT AND CONTROL UNIT

In a new control unit for cryogenic liquid nitrogen, resistance temperature bulbs (RTB's) are used to sense the level of the liquid. Relay logic generates a control signal that indicates liquid height. This novel application of a level-sensing control system may be of interest to laboratories working with cryogenic liquids. It appears that the use of RTB's offers increased accuracy over carbon resistors.

An 11-channel unit, in which carbon resistors are used as sensing elements, indicates, by means of indicator lights, liquid level in 10-percent increments. An adaptation of the display circuit of this device is used in the new liquid-level control unit. Only two channels are

used and the RTB's instead of resistors, are used. The liquid level will rise and fall between the two limits established by the locations of the upper and lower RTB's. Provisions are made for remote indicator lights by bringing the level signals out to a terminal strip.

Source: L. L. Stucke of
Rockwell International Corp.
under contract to
Marshall Space Flight Center
(MFS-19228)

Circle 18 on Reader Service Card.

DIGITAL MAGNETIC-TAPE SKEW ANALYZER

The digital magnetic-tape skew analyzer consists of logic and sensing circuits for checking computer-recorded, 7-track, IBM-compatible tapes for skew and error performance, thus providing a means for determining performance levels for computer tapes. The device can be constructed in a moderately-equipped electronics shop by technician-level personnel, and it can be used by commercial organizations that keep large quantities of transaction records on magnetic tape. The skew analyzer currently is being used to evaluate

computer-generated tapes in 200, 555.5, and 800 bpi densities, when read from an IBM 729-VI tape unit operating at a tape speed of 112.5 in/s (285.75 cm/s).

Source: William C. Webb
Goddard Space Flight Center
(GSC-10224)

Circle 19 on Reader Service Card.

TESTING ELECTROSTATIC PROPERTIES OF DIELECTRIC FILM

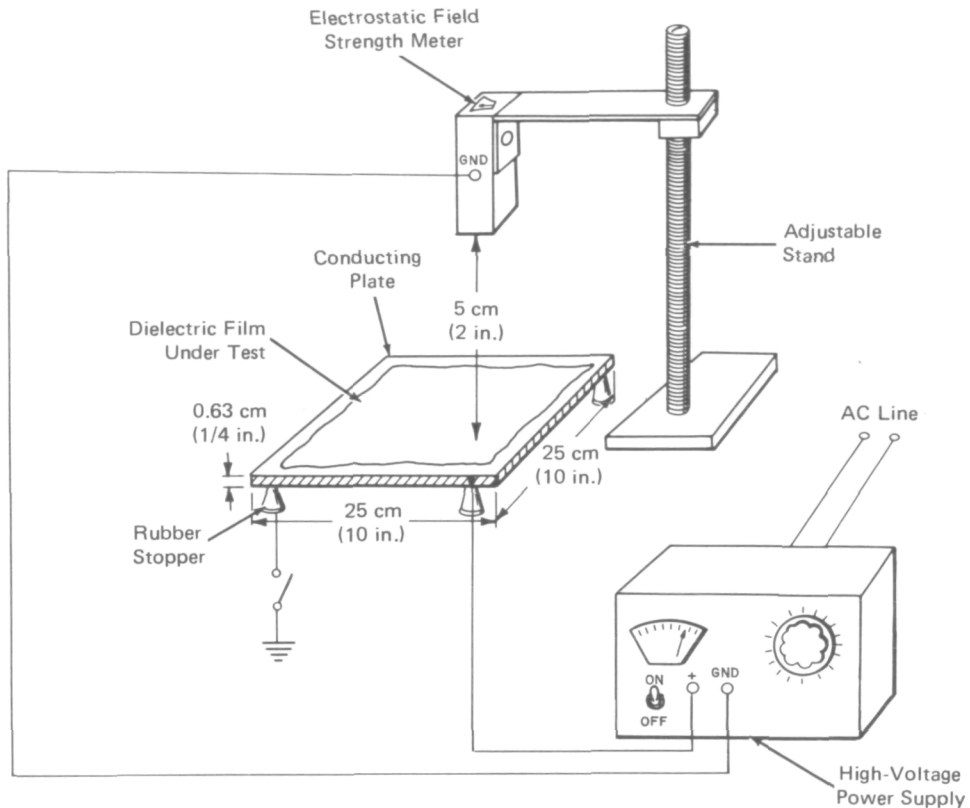

System for Measuring the Electrostatic Properties of Dielectric Film

The system shown in the figure determines the electrostatic properties of dielectric film by the measurement of the decay rate (dissipation) of an electrostatic charge placed on the film. The dielectric film is placed in contact with a conducting plate, which is then connected to a high-voltage power supply. The conducting plate is charged and in turn charges the film by contact electrification. The plate is then disconnected from the voltage source, and a charge sensor monitors the rate of decay of the charge on the dielectric film. A switched conductive path is provided between the conducting plate and ground; a series resistor may be added to this circuit if desired. Automatic timing and charge monitoring are preferred for maximum accuracy, especially when dielectrics that have been treated with antistatic agents are being tested.

The system overcomes three major disadvantages of previous triboelectric methods. First, when a charge is

created by rubbing two dissimilar materials together, it may not be reproducible because of the difficulty of applying the same amount of pressure every time. This difficulty is bypassed by the new system, as rubbing the materials to create the charge is not necessary. Second, because the two surfaces being rubbed together are not always the same, different frictional effects must be considered; the new system avoids this problem too. Finally, there is no lost-time interval between placing a charge on the surface and moving the surface to an electric field meter to record the decay rate.

Source: J. E. Johnston
Marshall Space Flight Center
(MFS-22129)

Circle 20 on Reader Service Card.

ANGLE-VERSUS-TORQUE MEASURING SYSTEM

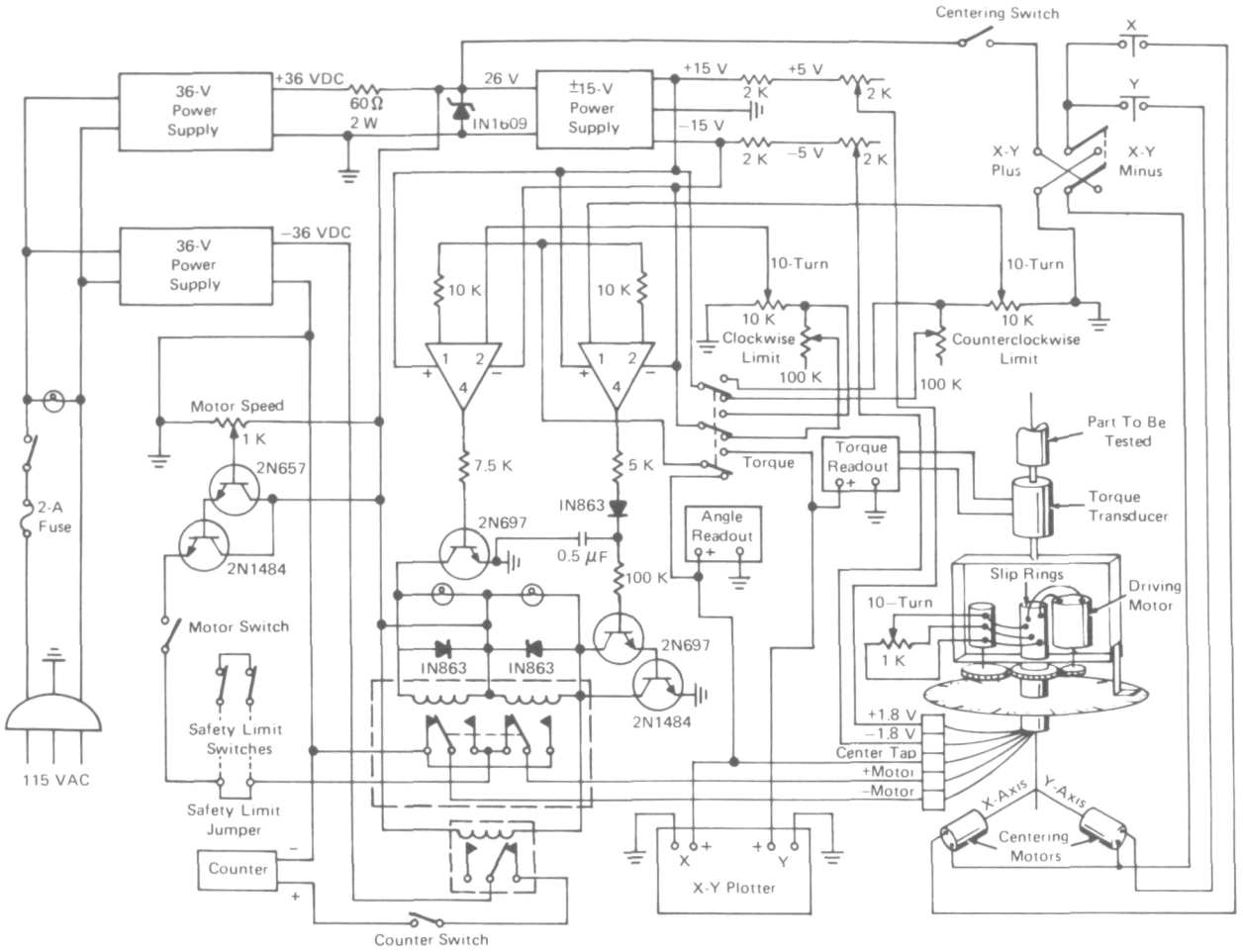

Torsion-Measuring System

A recently developed testing system applies a known torque to a specimen, measures the resultant angular deflection, and prints the resulting hysteresis curves on an X-Y plotter. It may be of use in making torsional measurements and in measuring the viscoelastic properties of materials by forced-torsional oscillations.

The electromechanical system (see figure) consists of two subsystems. The first is a mechanical device which twists the free ends of a specimen, placing it in torsion. The device includes mechanized centering and a variable multiple-turn potentiometer. An electrical output signal is proportional to the twist in a calibrated torque bar.

The second subsystem consists of an electronic circuit which controls the mechanical subsystem. The circuit also processes the torque and angular deflection signals that are the input to the X-Y plotter which produces hysteresis plots.

Source: Richard A. Abercrombie
Goddard Space Flight Center
(GSC-11538)

Circle 21 on Reader Service Card.

STRAP-TENSION METER

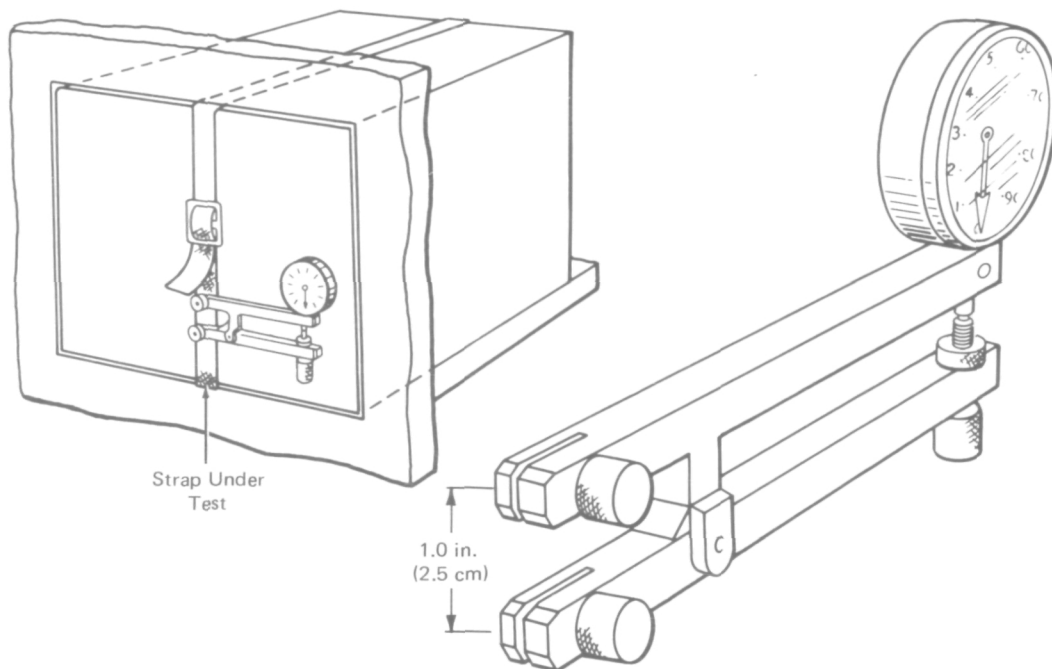

Strap-Tension Meter

In some applications it may be necessary to adjust the tension in a fabric restraining strap to a specific range. This tension is usually measured between the strap buckle and one end which is fastened to a wall, a floor or other structure.

The strap-tension meter shown in the figure indicates the actual elongation of a fabric strap over a 1.0-in. (2.5-cm) span, measured between pins in the ends of the arms. Tests may be run to determine the amount of elongation for various loads, and a curve then can be plotted of stretch versus load. Because there is a three-to-one multiplication factor in the meter arms,

the dial indicator reads three times the actual displacement. Such a device could be used in the furniture-upholstering industry, or it could be used to measure the tension in metal straps when test holes in the strap could be tolerated.

Source: G. V. Buhler and D. E. Havens of
McDonnell Douglas Corp.
under contract to
Marshall Space Flight Center
(MFS-22189)

Circle 22 on Reader Service Card.

Patent Information

The following innovations, described in this Compilation, have been patented or are being considered for patent action as indicated below:

Multiplate Focusing Collimator (Page 1) MFS-20932

and

A Compton Scatter Attenuation Gamma Ray Spectrometer (Page 6) MFS-21441

and

Sample Insertion Method for Continuous Electrophoresis Apparatus (Page 20) MFS-21395

and

Testing Electrostatic Properties of Dielectric Film (Page 25) MFS-22129

and

Strap-Tension Meter (Page 27) MFS-22189

These inventions are owned by NASA, and patent applications have been filed. Inquiries concerning nonexclusive or exclusive license for their commercial development should be addressed to:

Patent Counsel
Marshall Space Flight Center
Code CC01
Marshall Space Flight Center, Alabama 35812

A Heat-Flow Calorimeter (Page 14) GSC-11434

This invention has been patented by NASA (U.S. Patent No. 3,813,937). Inquiries concerning nonexclusive or exclusive license for its commercial development should be addressed to:

Patent Counsel
Goddard Space Flight Center
Code 204
Greenbelt, Maryland 20771

Ion-Tracer Anemometer (Page 17) MFS-22534

Inquiries concerning rights for the commercial use of this invention should be addressed to:

Patent Counsel
Marshall Space Flight Center
Code CC01
Marshall Space Flight Center, Alabama 35812



079 001 TB-ALL 750820 T19649
THE CONGRESS
COMMITTEE ON AERONAUTICAL & SPACE SCIEN
ATTN: MR JAMES GEHRIG
231 SENATE OFFICE BUILDING
WASHINGTON DC 20510

POSTMASTER: If Undeliverable (Section 158
Postal Manual) Do Not Return

"The aeronautical and space activities of the United States shall be conducted so as to contribute . . . to the expansion of human knowledge of phenomena in the atmosphere and space. The Administration shall provide for the widest practicable and appropriate dissemination of information concerning its activities and the results thereof."

— NATIONAL AERONAUTICS AND SPACE ACT OF 1958

NASA TECHNOLOGY UTILIZATION PUBLICATIONS

These describe science or technology derived from NASA's activities that may be of particular interest in commercial and other non-aerospace applications. Publications include:

TECH BRIEFS: Single-page descriptions of individual innovations, devices, methods, or concepts.

TECHNOLOGY SURVEYS: Selected surveys of NASA contributions to entire areas of technology.

OTHER TU PUBLICATIONS: These include handbooks, reports, conference proceedings, special studies, and selected bibliographies.

Technology Utilization publications are part of NASA's formal series of scientific and technical publications. Others include Technical Reports, Technical Notes, Technical Memorandums, Contractor Reports, Technical Translations, and Special Publications.

Details on their availability may be obtained from:

Details on the availability of these publications may be obtained from:

National Aeronautics and
Space Administration
Code KT
Washington, D.C. 20546

National Aeronautics and
Space Administration
Code KS
Washington, D.C. 20546