

General Disclaimer

One or more of the Following Statements may affect this Document

- This document has been reproduced from the best copy furnished by the organizational source. It is being released in the interest of making available as much information as possible.
- This document may contain data, which exceeds the sheet parameters. It was furnished in this condition by the organizational source and is the best copy available.
- This document may contain tone-on-tone or color graphs, charts and/or pictures, which have been reproduced in black and white.
- This document is paginated as submitted by the original source.
- Portions of this document are not fully legible due to the historical nature of some of the material. However, it is the best reproduction available from the original submission.

EX

VOL. I

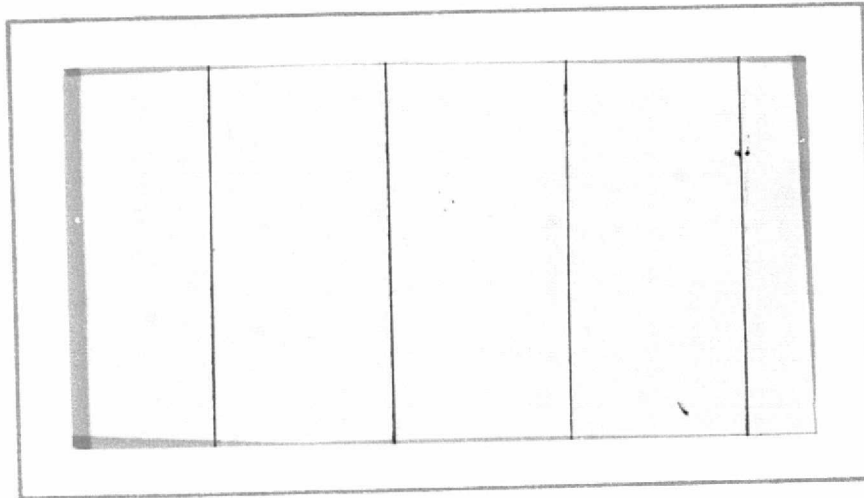

(NASA-CR-143967) TRACK/TRAIN DYNAMICS TEST
 REPORT TRANSFER FUNCTION TEST. VOLUME 1:
 TEST (Martin Marietta Corp.) 130 p HC \$5.75
 CSCL 14B

N75-33401

Unclas
 42660
 G3/37

MARTIN MARIETTA

POST OFFICE BOX 179, DENVER, COLORADO 80201



TB-005-TF

30 May 1975

TRACK/TRAIN DYNAMICS

TEST REPORT

TRANSFER FUNCTION TEST

Volume I

TEXT

TR-005-TF
30 May 1975

TRACK/TRAIN DYNAMICS
TEST REPORT
TRANSFER FUNCTION TEST

Contract NAS8-29882

Prepared by:

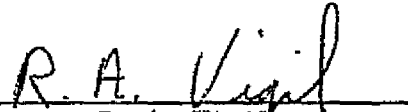

R. A. Vigil
Staff Engineer
Space Systems Dynamics

Approved by:

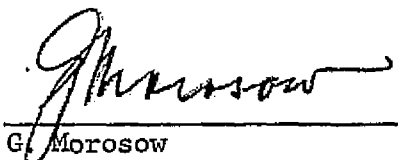

G. Morosow
Program Manager
Track/Train Dynamics

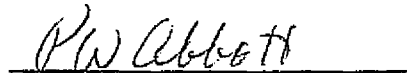

P. W. Abbott
Technical Director
Track/Train Dynamics

MARTIN MARIETTA CORPORATION
Denver Division
Denver, Colorado 80201

FOREWORD

This document is submitted in accordance with the requirements for Technical Reports as specified by NASA Contract NAS8-29882.

CONTENTS

	<u>Page</u>
Title Page	i
Foreword	ii
Contents	iii, iv
1.0 SCOPE	1
1.1 Purpose	1
1.2 Summary	1
2.0 APPLICABLE DOCUMENTS	1,2
3.0 TRANSFER FUNCTION TEST DESCRIPTION	2
3.1 Test Objective	2
3.2 Specimen/Test Configurations	2
3.3 Facility Description	2,3
3.3.1 Handling Equipment	3
3.3.2 Fixturing	3
3.3.3 Hydraulic System	3
3.3.4 Control System	3
3.3.5 Data Acquisition/Reduction System	3
3.4 Test Summary	3,4
3.4.1 Test Procedure	4
3.4.2 Instrumentation Summary	4
3.4.3 Data Summary	4
3.4.4 Detailed Test Description	4,5
4.0 SUMMARY OF RESULTS	5
5.0 ABBREVIATIONS AND ACRONYMS	6

Figures

1-3	Y-Axis Test Configuration	7-9
4,5	X-Axis Test Configuration	10,11
6	Z-Axis Test Configuration	12
7,8	Slide Plate Assembly	13,14
9	Stationary Truck Support	15

	<u>Page</u>
10	Annin Bypass Control Valve 16
11	Remote Control Console 17
12	Time Data Digital Computer 18
13	100 Channel Tape Recorder System 19
14	Crystal Accelerometer Charge Amplifiers 20
15	Displacement Transducer Signal Condi- tioning System 21
16	Strain Gage Signal Conditioning System 22

Tables

I	Track/Train Transfer Function Test Summary 23,24
II	Data Summary 25-43

Appendices

A	Transfer Function Test Requirements Document, Post-Test Update A1-A14
B	Transfer Function Test Procedure Document, Post-Test Update B1-B67

Enclosures

Volume II	Data Book, Y-Axis Tests, Actuators 180° Out of Phase, Runs: 6, 9, 13, 14 and 23 1-268
Volume III	Data Book, Y-Axis Tests, Actuators In Phase, Runs: 15, 18, 19 and 20 1-211
Volume IV	Data Book, X-Axis Test, Actuators 180° Out of Phase, Run 30 and Z-Axis Test, Single Actuator, Run 46 1-127

1.0 SCOPE

1.1 Purpose - This report presents a description of the transfer function test performed on an open hopper freight car loaded with 80 tons of coal. Also presented are the test data and a post-test update of the requirements document and test procedure. Included in the text is a statement of the test objective, a description of the test configurations, test facilities, test methods, data acquisition/reduction operations and a chronological test summary.

1.2 Summary - The transfer function test was conducted during the period extending from 12 March through 31 March 1975. Control system evaluation was performed prior to 12 March 1975 and data reduction continued beyond 31 March 1975. The test program was conducted at the Martin Marietta Corporation Structures Test Facility in Denver, Colorado.

An index to the data for the three test configurations (X, Y and Z-axis tests) is presented in Table I. Also, contained in Table I is the test sequence, run number, test reference and input parameters. Y-axis data are presented in Volumes II and III. Volume IV contains X and Z-axis data. A detailed index to the data is contained in each volume. Appendix A and B contain a post-test update of the requirements document and test procedure. The procedure contains photographs of transducer locations and the test historical log.

The data is currently being compared with analytical model data for model validation.

2.0 APPLICABLE DOCUMENTS

The following documents of exact issue shown, form a part of this document to the extent specified herein. This document shall govern where differences occur in presented material.

P74-48338-1, "Track-Train Dynamics Analysis and Test Program"

TS-005-TF, "Track/Train Dynamics, Test Requirements Document, Transfer Function Test," dated 16 May 1975

TP-005-TF, "Track/Train Dynamics, Test Procedure, Transfer Function Test," dated 16 May 1975

LAB 1007302, "Track-Dynamic Analysis GVS and Transfer Function Test," Test Fixture Drawings

1923-010000, Time Data Operations Manual

LAB 0212205, "Time Data 1923 Sinusoidal Vibration Control System"
1923-5017, "Time/Data Sinusoidal Vibration Control Manual"

3.0 TRANSFER FUNCTION TEST DESCRIPTION

3.1 Test Objective - The objective of the transfer function test was to obtain data for the validation of the freight car nonlinear elastic model.

3.2 Specimen/Test Configurations - The test specimen consisted of an L&N RR model M-042-174 80 ton open hopper freight car with ASF-11 trucks. Details concerning the test article general arrangement can be found in Appendix A, Figure 1.

The first test configuration was the fully loaded car containing approximately 162,000 lbs of coal supported on ASF-11 trucks. The wheel/axle sets of the test truck (the same one used for static tests) were supported on slide plate assemblies, two of which were equipped with load cells for measuring vertical forces. These load cells were positioned underneath the wheels where the force input was applied. The wheel/axle assemblies of the other truck were supported on spacer assemblies which brought the car to a level position. Two hydraulic actuators were rigidly coupled to the axles of the test truck for Y-axis testing and actuator forces were reacted by a support fixture rigidly coupled to the test facility floor. A hydraulic power supply was placed in the proximity of the actuators. The freight car and truck assemblies were in a standard operational configuration.

In the second test configuration, the car was supported the same way as the first; however, the actuators were positioned for X-axis testing and were rigidly attached to the front axle of the truck assembly. The slide plate assemblies with the load cells were positioned beneath the wheels with the actuator attachment.

The third configuration involved the use of a single actuator positioned at one side of the middle of the car for Z-axis testing. All other conditions were the same as test configurations 1 and 2. Each of the above test configurations are depicted in Figures 1 through 6 respectively.

3.3 Facilities Description - The tests described in this document were conducted at the Martin Marietta Corporation Structures Laboratory located in Denver, Colorado. All the test equipment used during this test was in current calibration throughout the test program except for 10 charge amplifiers which required an extension beyond 24 March 1975.

3.3.1 Handling Equipment - Two 100 ton Regent hydraulic jacks and four 50 ton Merrill hydraulic jacks were used to raise the freight car and truck assembly during setup operations. A rented conveyor system was used to unload the coal via the hopper hatches which were opened and closed with the aid of a hydraulic jack.

3.3.2 Fixturing - The test truck assembly was supported on four MMC slide plates and the actuator forces were reacted by support fixtures as shown in Appendix B, Figure 7.5.

3.3.3 Hydraulic System - Forces were applied to the wheel axles by two hydraulic Moog actuators for the Y and X axis tests and by a single actuator for the Z axis tests. The deliverable force rating of an actuator is 14,040 pounds-peak with a 3000 psi differential pressure across the actuator piston. The hydraulic power supply pressure was maintained at 3000 psi by a 30 gpm Denison hydraulic pump during testing. An Annin control valve was used as a hydraulic oil safety bypass during Z axis testing to preclude the possibility of damage if motion were abruptly terminated (see Figure 7).

3.3.4 Control System - The force input to the test specimen was automatically controlled by a Time Data 1923 digital control system with the master gain located in a remote control console. The control system was programmed to control the highest of two forces or a single force within a selectable amplitude window. Manual operation was optionally selectable with the use of an analog oscillator in the remote control console or the synthesizer used with the digital system. Computer instructions and post-test printout were provided by a remote TTY. Input force signals, the drive signal and the servo-valve drive amplifier signals were monitored on a multiplexed scope during testing. Actuator phasing (0° or 180°) was accomplished by reversing the output of one of the valve drive amplifiers. The systems described in this section are shown in Figures 8 and 9.

3.3.5 Data Acquisition/Reduction System - The data from each run was recorded on a Honeywell magnetic tape recorder system equipped with a Vidar 100 channel FM multiplex system. Signal conditioning was accomplished with the use of charge amplifiers, LVDT balance amplifiers, and bridge balance amplifiers. Standard accelerometers, displacement transducers, and strain gage transducers were used to measure the motion of the test specimen. A block diagram of the control and data acquisition/reduction systems is presented in Appendix B, Figure 7.4. In addition, photographs of these systems are presented in Figures 10 through 13.

3.4 Test Summary - In order to accomplish the stated objective of the test, it was conducted in accordance with the requirements specified in the test requirements document (TS-005-TF, Appendix A). A chronological test sequence, along with run numbers, test reference, input parameters, and data reference is presented in Table I. Test modifications were generated by the test control board and were implemented during the course of the test.

3.4.1 Test Procedure - The performance of each vibration test, identified by run numbers in Table I, was implemented by following the steps described in the test procedure (TP-005-TF, Appendix B). The historical log of daily activities is included with the test procedure.

3.4.2 Instrumentation Summary - A maximum of 44 measurements were recorded for a given test run as reflected by the data in Volumes II, III and IV. Instrumentation locations are identified in Appendix B, Figures 7.2 and 7.3. Coordinates of displacement transducers are presented in Appendix B, Table 8.0; also presented are photographs of instrumentation locations in Figures 7.2a through 7.2f and 7.3a through 7.3t.

3.4.3 Data Summary - Selected test data are presented in Volumes II, III and IV in the form of transfer function plots. Also presented is a listing of controlling force and associated frequency interval for the two actuator tests along with a listing of transducer sensitivities. Quick look oscillograph data, computer printout, and magnetic tapes generated during the test are available and are being maintained in data retention files.

3.4.4 Detailed Test Description - The following test descriptions provide information concerning the performance of each major test sequence. In general, control system limitations were experienced during testing which resulted in premature test run termination (aborts). These aborts were related to fixture resonances, fixture cross coupling and specimen/actuator interaction. Typically, a test input spectrum and tolerance was entered into the computer program based on hydraulic system limitations. Data from test attempts and manual excitation at discrete frequencies optimized this spectrum which resulted in maximum input force and truck member relative motion. Low level tests preceded maximum input tests to preclude the possibility of over testing the specimen. The above approach produced the desired result below 20 Hz where motion was significant; however, aborts were still experienced above 20 Hz primarily from fixture resonances. These aborts were identified by computer post-test printout messages, i.e. "maximum drive limit exceeded" and "control limit exceeded".

Runs 1 through 5 - Precursor tests at three force levels were conducted in the Y-axis with the actuators 180° out-of-phase. Insufficient motion was observed during these tests and the following configuration changes were made. The actuator reaction fixture was stiffened by boxing in "I" beam sections and adding additional gussets. The layer of polychor tape was removed from the bearing surface of the slide plates and molydisulfide lubricant was used between the movable plate which contained polychor tape and the bearing plate. Finally, shims were added between the spherical bearing end pins of the actuators and the fixture clevis holes.

Runs 6 through 46 - Force input spectrums were optimized and test runs conducted in the Y, X and Z axes. Tests with the actuators

both in and out of phase were conducted in the Y and X axes. Z axis tests utilized a single actuator. Maximum relative motion of the truck members and the car was achieved while staying within the shaker system capability. Slide plates were inspected and lubricated between the Y and X axes tests. Longitudinal X motion was kept to a safe limit to insure that the specimen would remain on its supports. Low frequency control limits were set to ± 8 dB in order to accomplish Z axis testing (runs 44 through 46). Previous test limits were generally a maximum of ± 4 dB. Further details concerning each run are delineated in Table I.

4.0 SUMMARY OF RESULTS

The transfer function test of the loaded 80 ton open hopper freight car was successfully completed in accordance with the requirements specified in Appendix A. The transfer function data obtained is currently being compared with analytical data. The results of this comparison will be submitted in a subsequent report. A summary of the test transfer function data is presented in Table II which lists the maximum motion and frequency of selected runs for each measurement.

5.0 ABBREVIATIONS AND ACRONYMS

Btwn.	Between
Bol.	Bolster
Calib.	Calibration
Cap.	Capacity
CDC	Control Data Corporation
Ch.	Channel
Ck.	Check
Displ.	Displacement
ET	Electronic Technician
FS	Full Scale
Fwd	Forward
L.	Left
Lat.	Lateral
LVDT	Linear Variable Differential Transformer
Meas.	Measurement
Mfg.	Manufacturer
MMC	Martin Marietta Corporation
MSFC	Marshall Space Flight Center
MT	Mechanical Technician
NASA	National Aeronautics and Space Administration
No.	Number
O-Graph	Oscillograph
Osc.	Oscillator
Opp.	Opposite
Qty.	Quantity
Rel.	Relative
Rt.	Right
Sens.	Sensitivity
S. Fr.	Side Frame
SF	Safety
S.G.	Strain Gage
SW	Switch

TCB	Test Control Board
TD	Technical Director
TE	Test Engineer
TTY	Teletype Terminal
Typ.	Typical
TX, Y, Z	Theta X, Y or Z
U-D	Unholtz-Dickie Corporation
Vert.	Vertical
XDCR	Transducer

ORIGINAL PAGE IS
OF POOR QUALITY

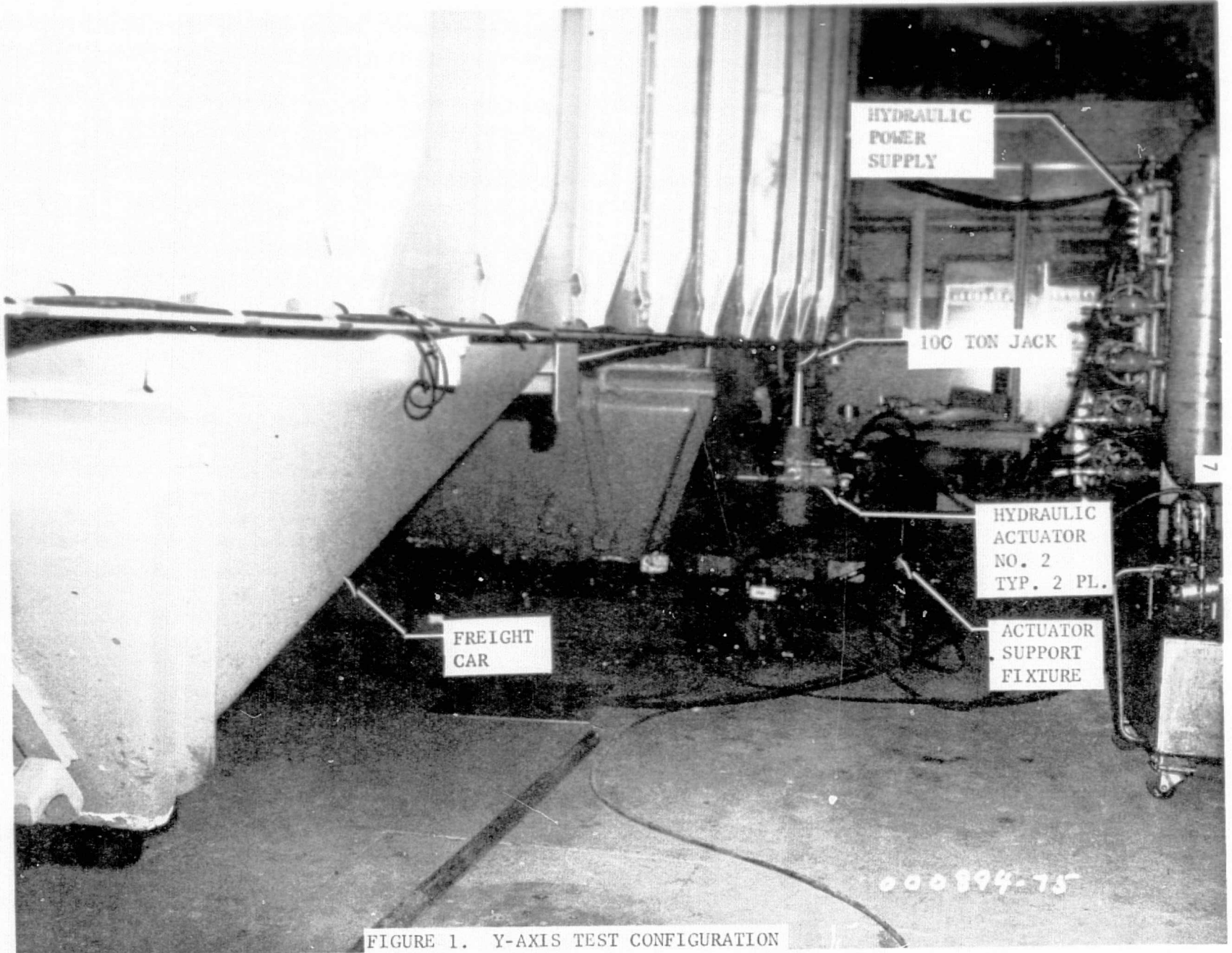

FIGURE 1. Y-AXIS TEST CONFIGURATION

ORIGINAL PAGE IS
POOR QUALITY

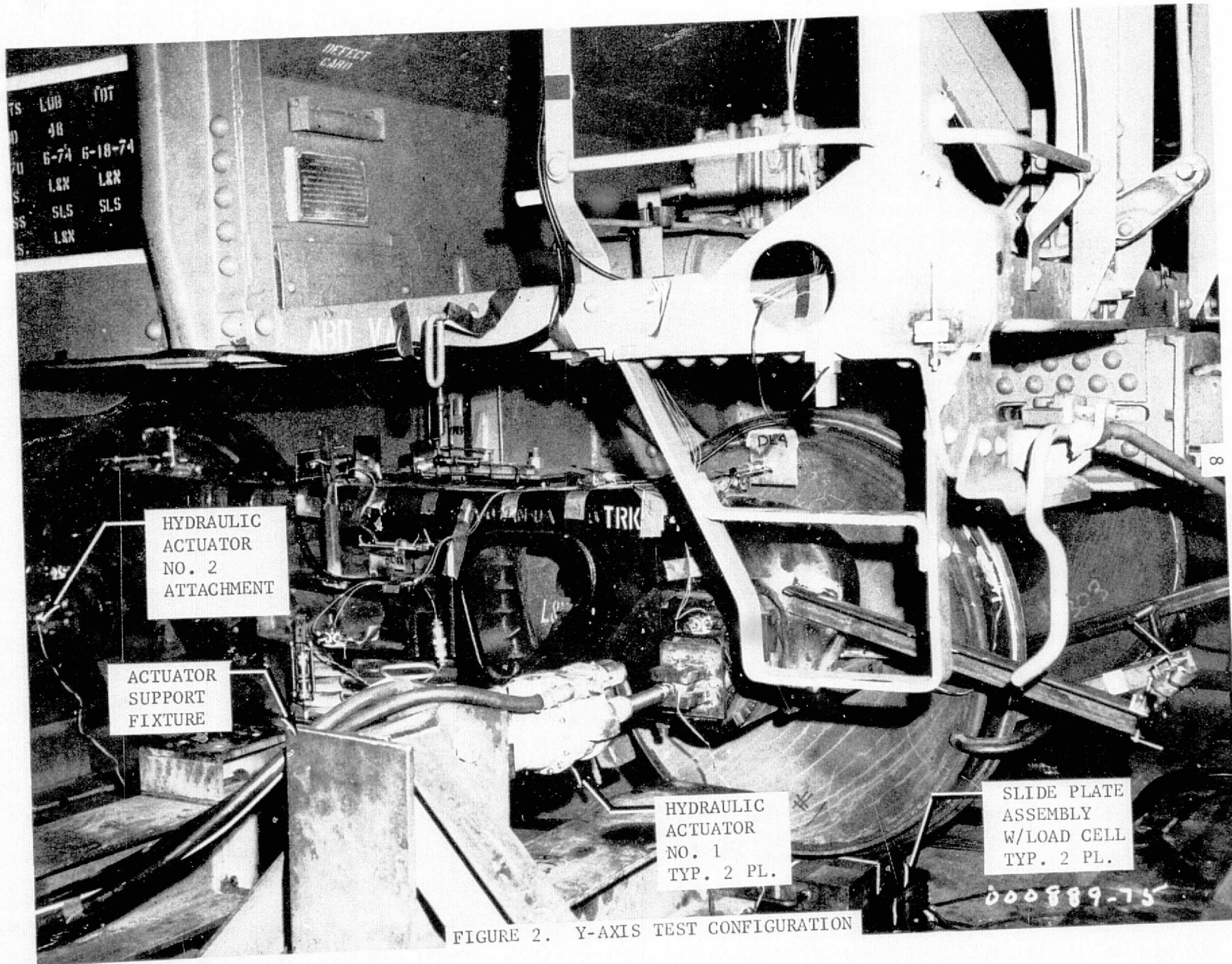

FIGURE 2. Y-AXIS TEST CONFIGURATION

ASTRONAUT PAGE 13
OF 100 QUALITY

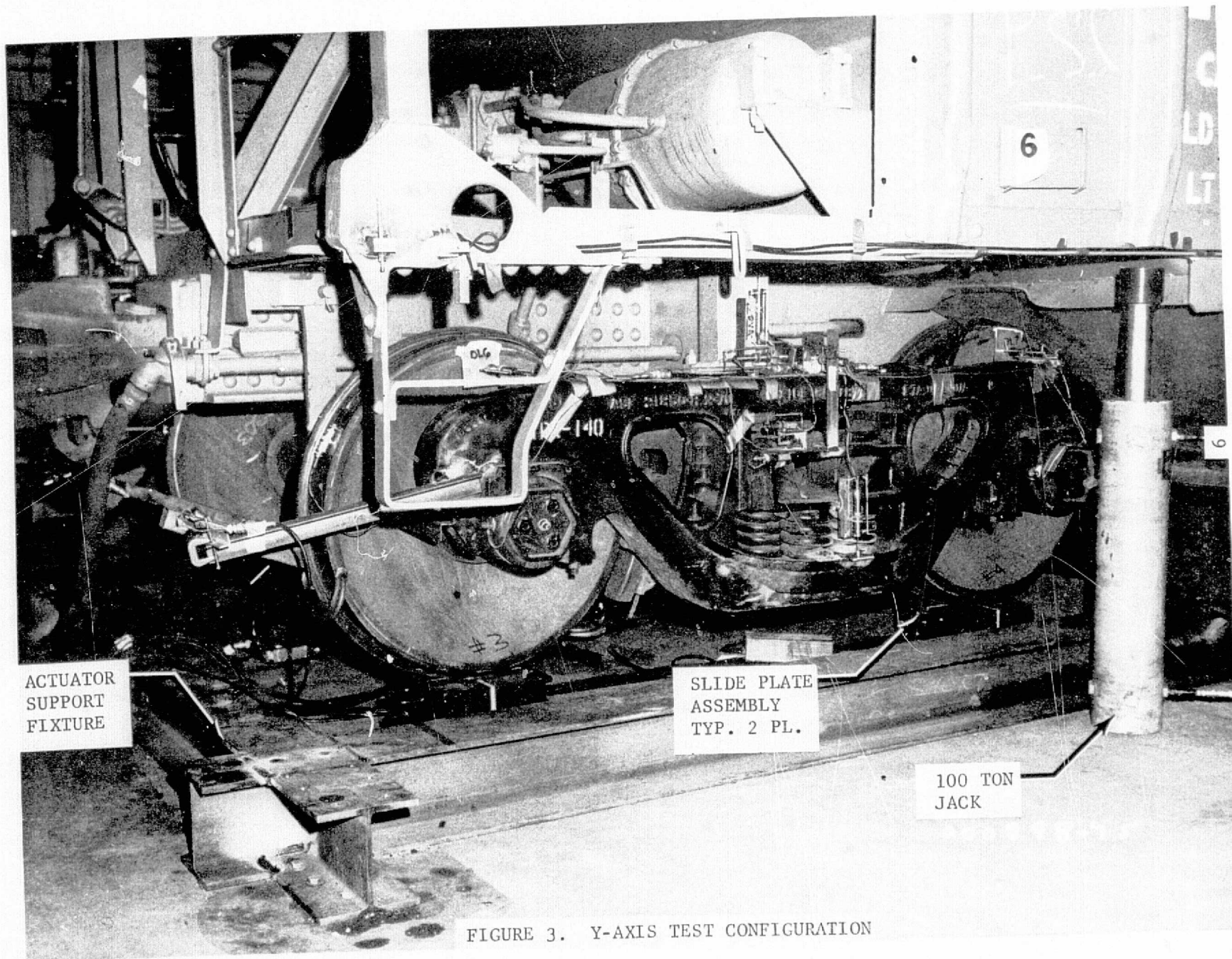

FIGURE 3. Y-AXIS TEST CONFIGURATION

ORIGINAL PAGE IS
OF POOR QUALITY

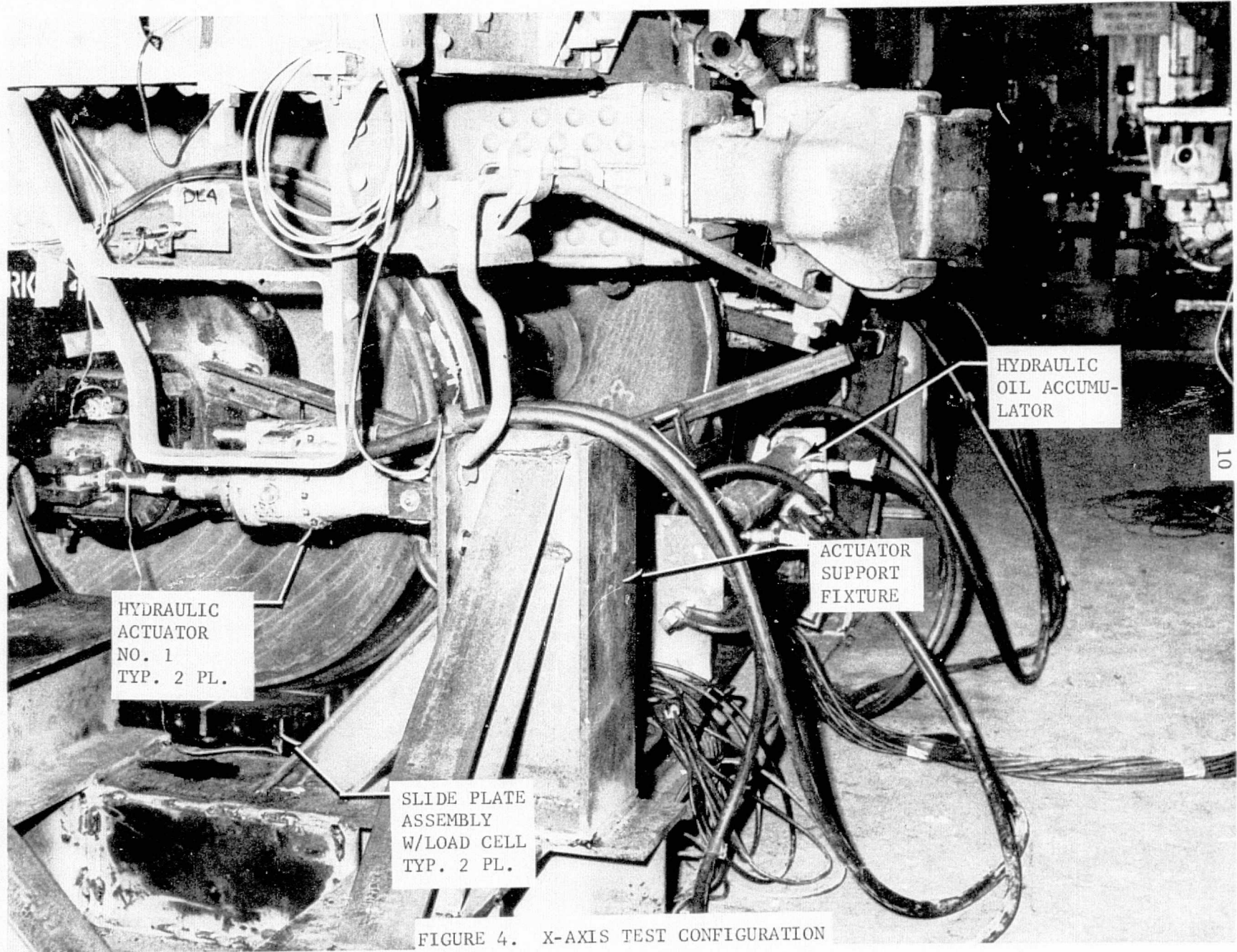
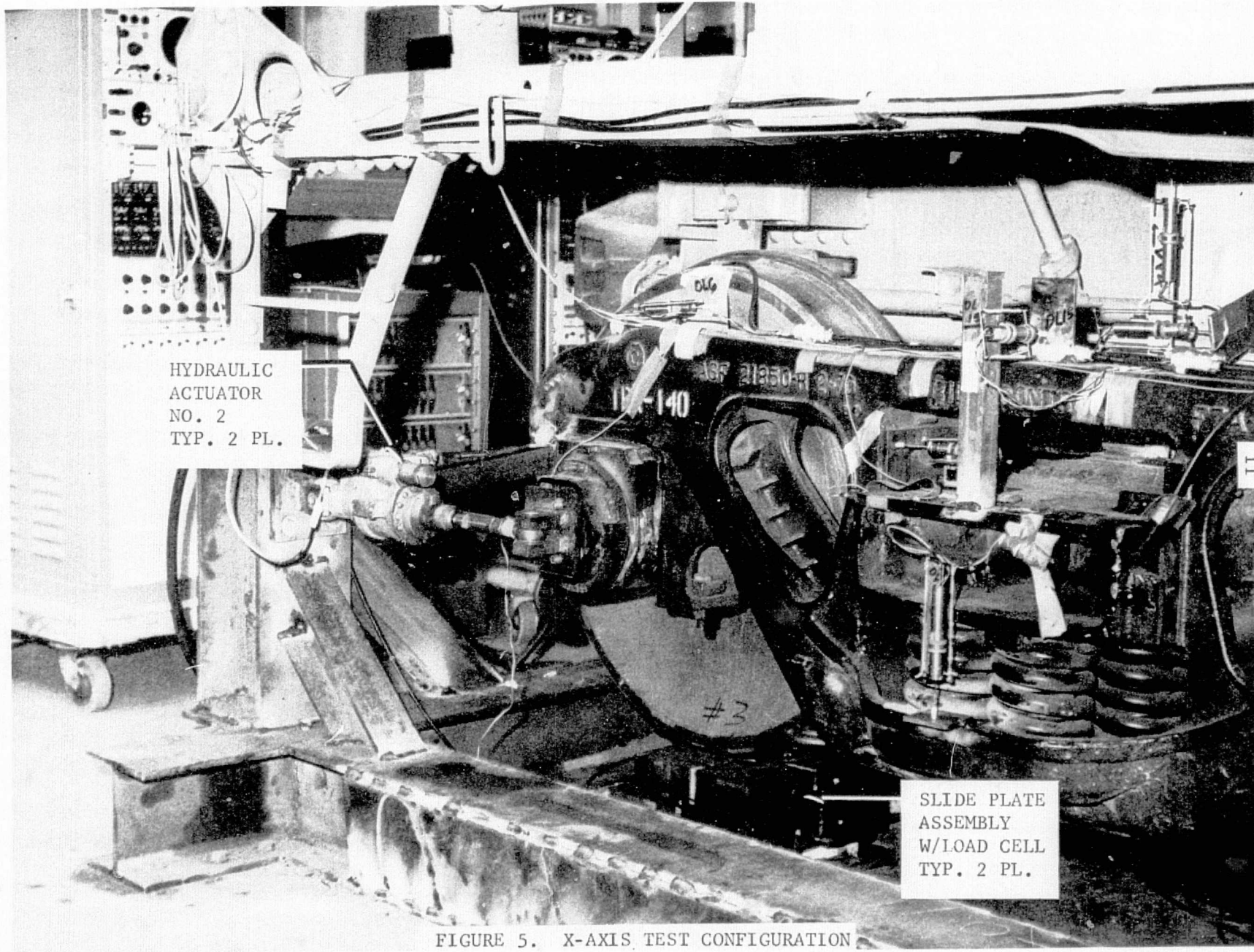

FIGURE 4. X-AXIS TEST CONFIGURATION

ORIGINAL PAGE IS
OF POOR QUALITY



HYDRAULIC
ACTUATOR
NO. 2
TYP. 2 PL.

SLIDE PLATE
ASSEMBLY
W/LOAD CELL
TYP. 2 PL.

FIGURE 5. X-AXIS TEST CONFIGURATION

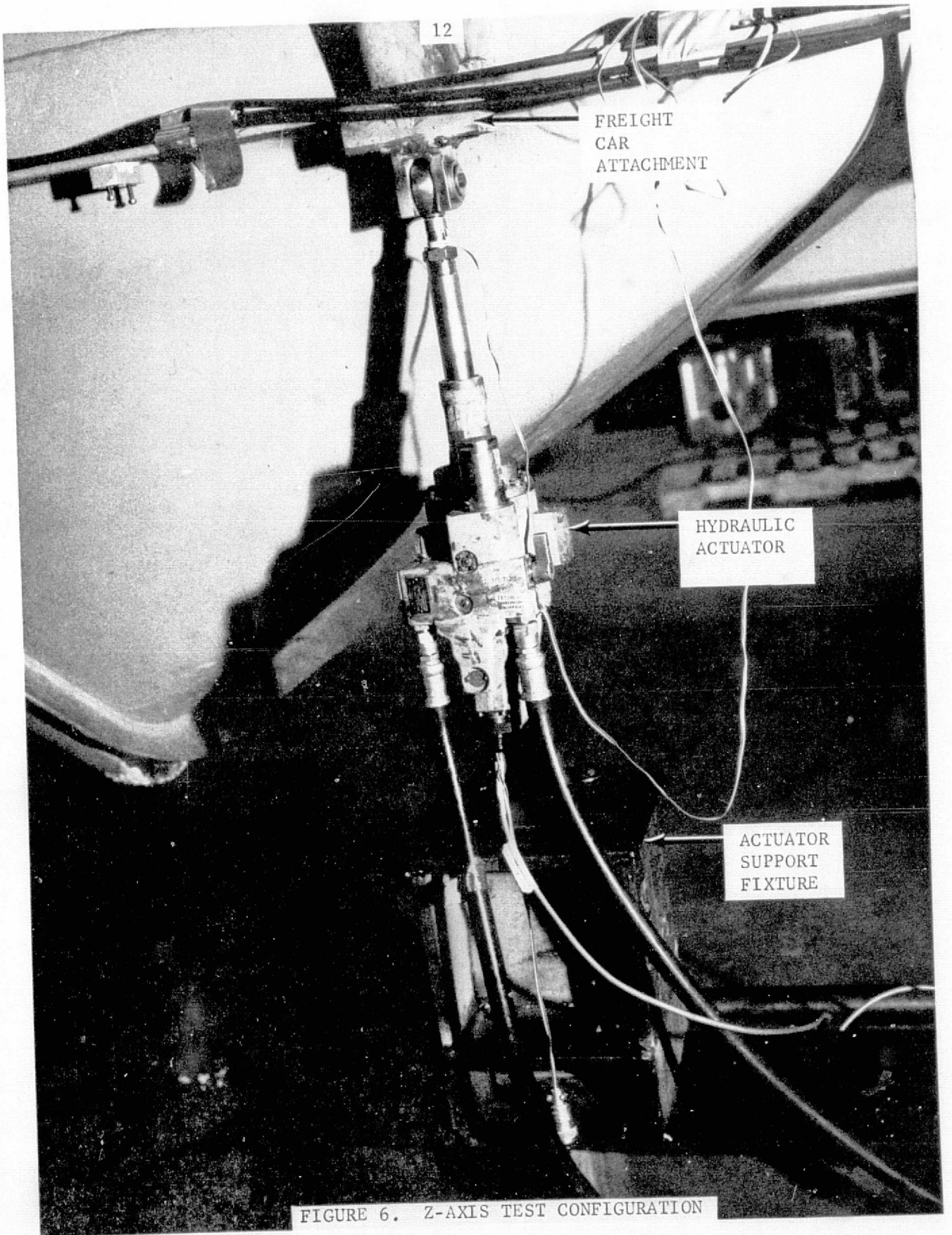

FIGURE 6. Z-AXIS TEST CONFIGURATION

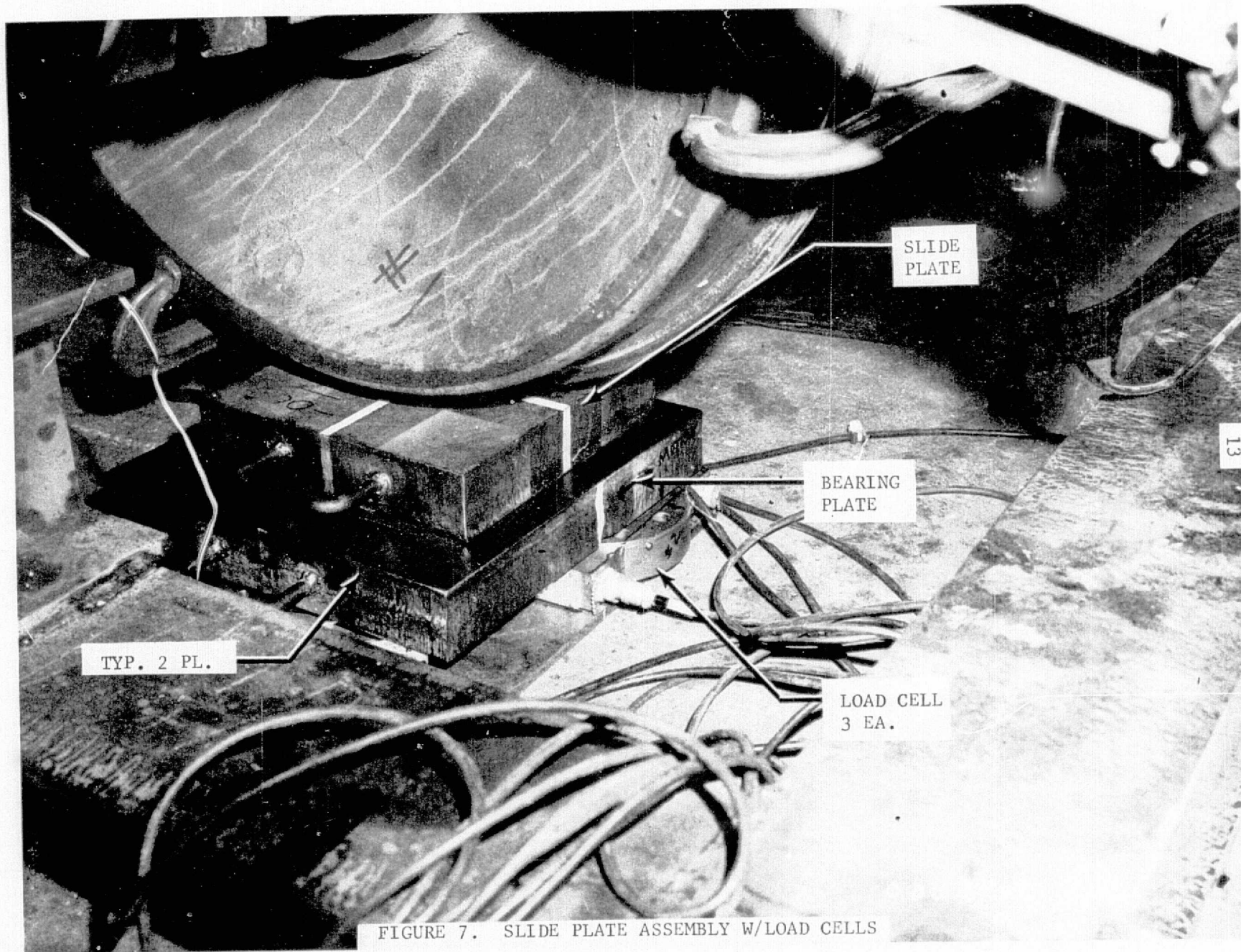

FIGURE 7. SLIDE PLATE ASSEMBLY W/LOAD CELLS

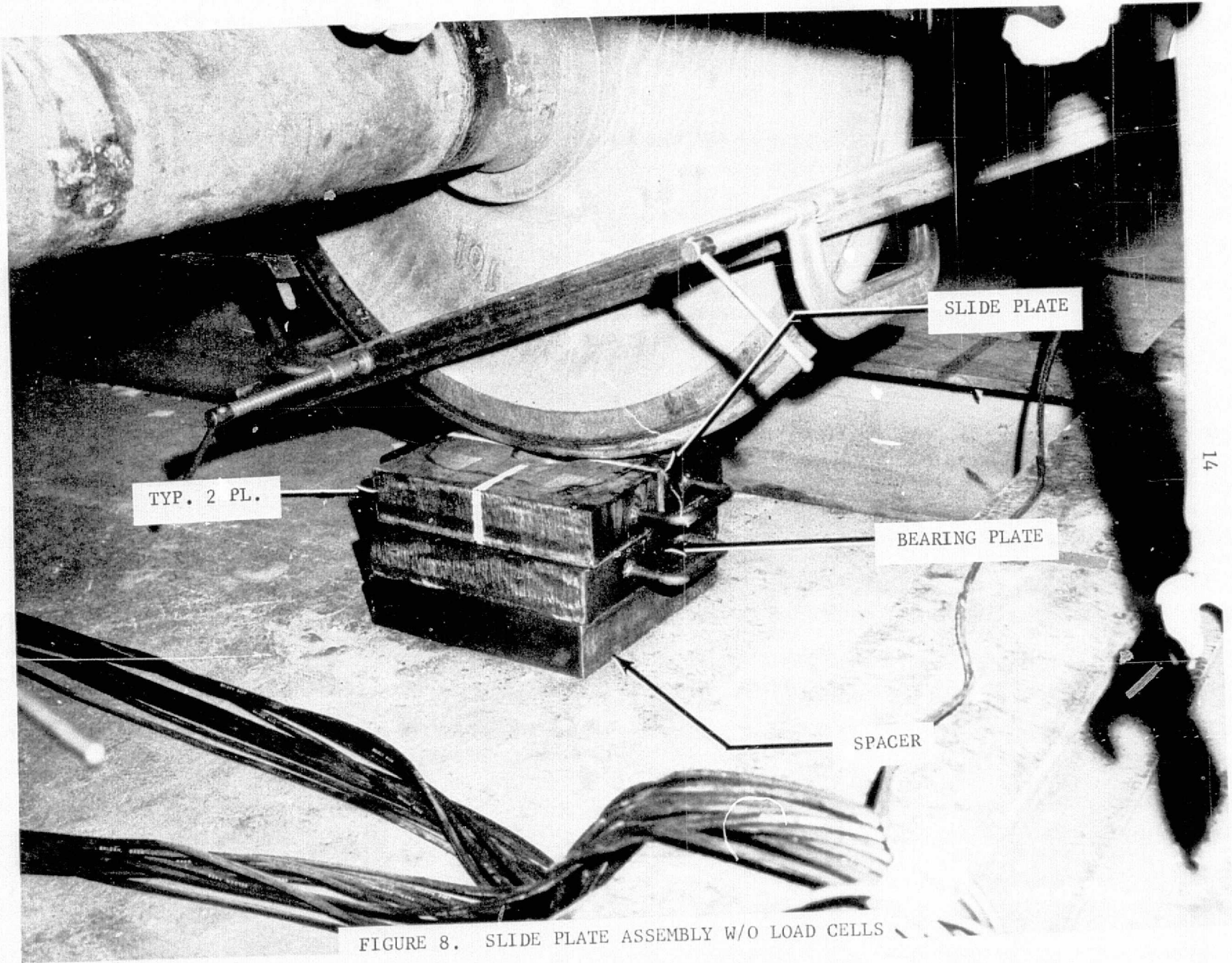

FIGURE 8. SLIDE PLATE ASSEMBLY W/O LOAD CELLS

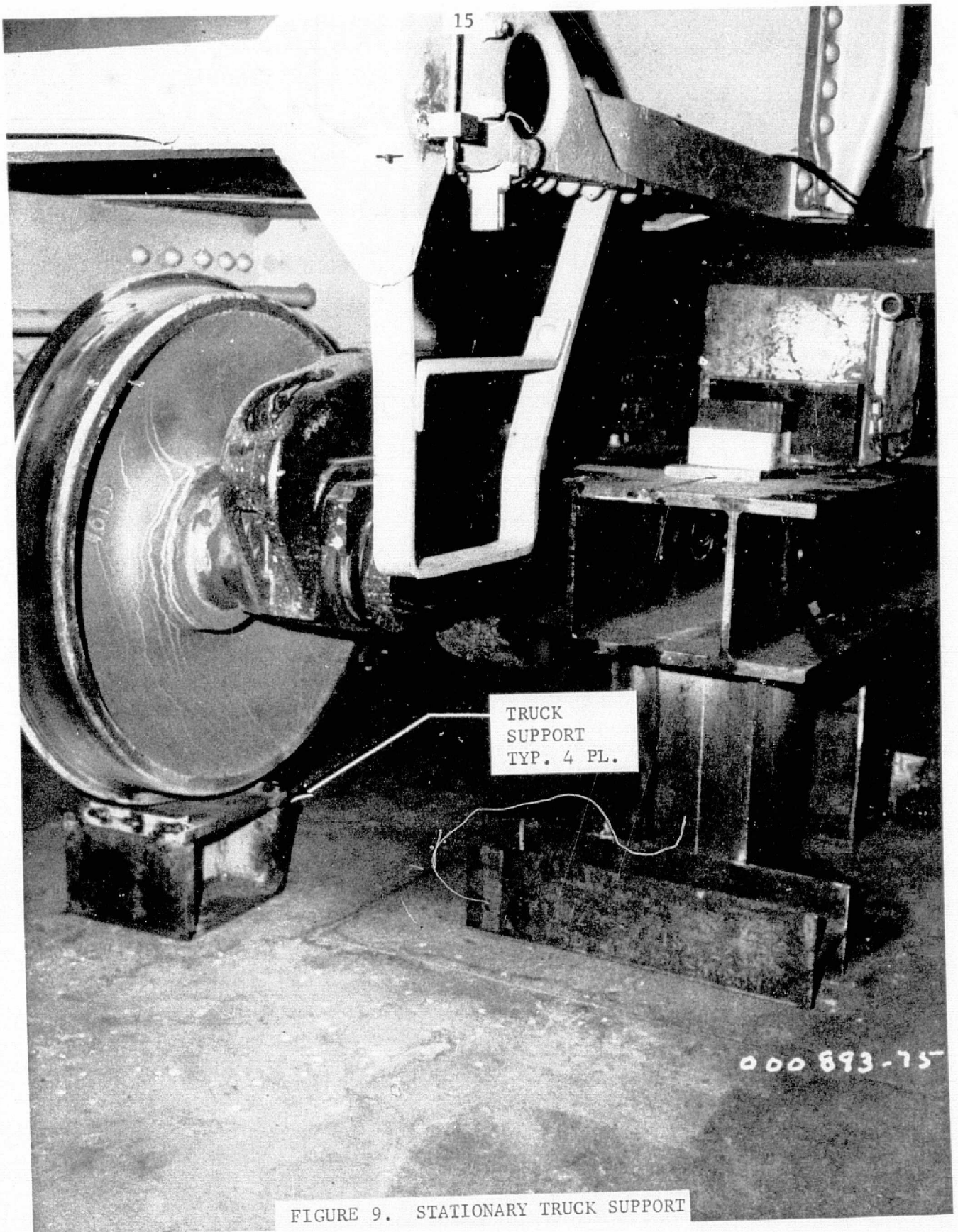

FIGURE 9. STATIONARY TRUCK SUPPORT

ORIGINAL PAGE IS
OF POOR QUALITY

ORIGINAL PAGE IS
OF POOR QUALITY

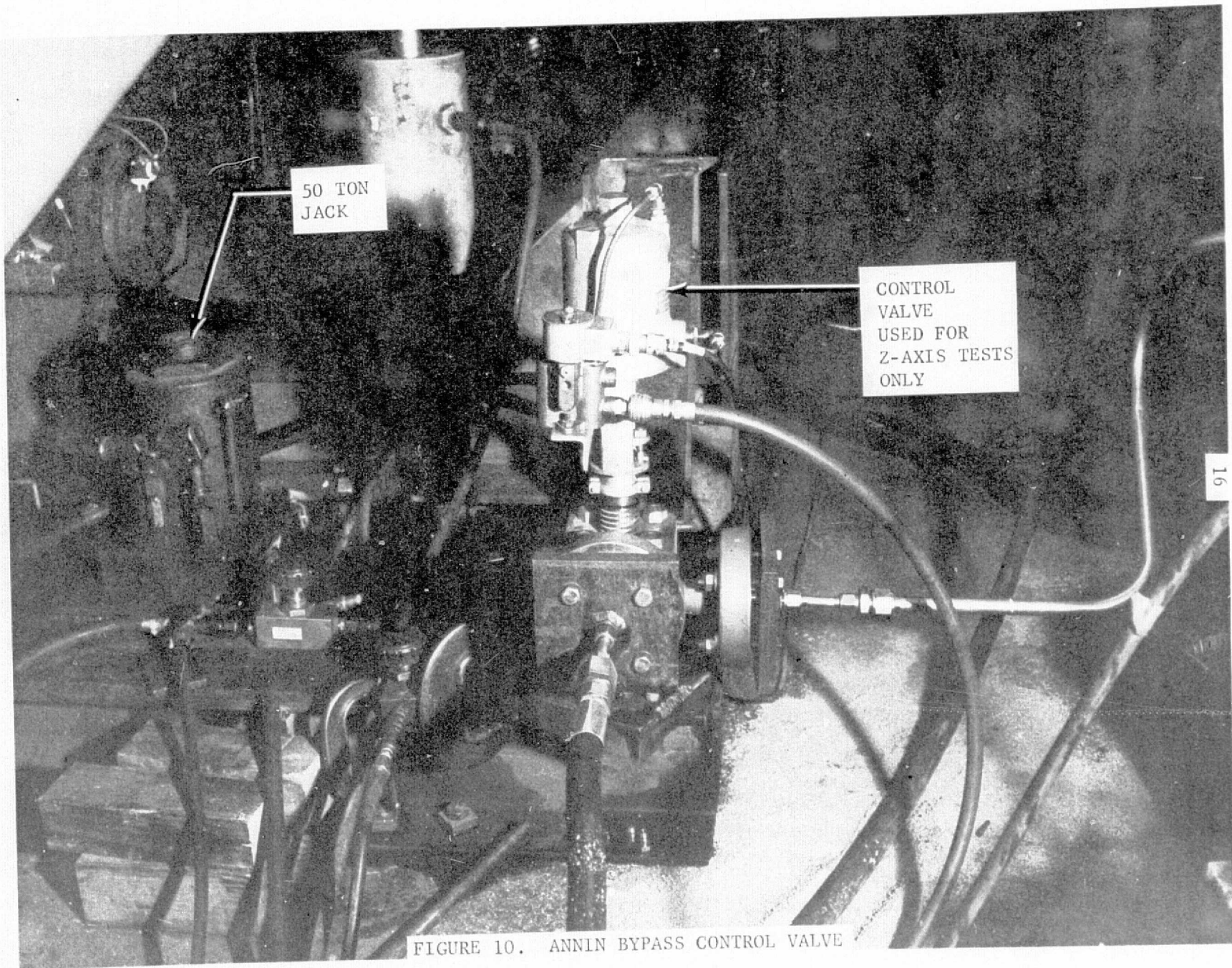

FIGURE 10. ANNIN BYPASS CONTROL VALVE

ORIGINAL PAGE IS
OF POOR QUALITY

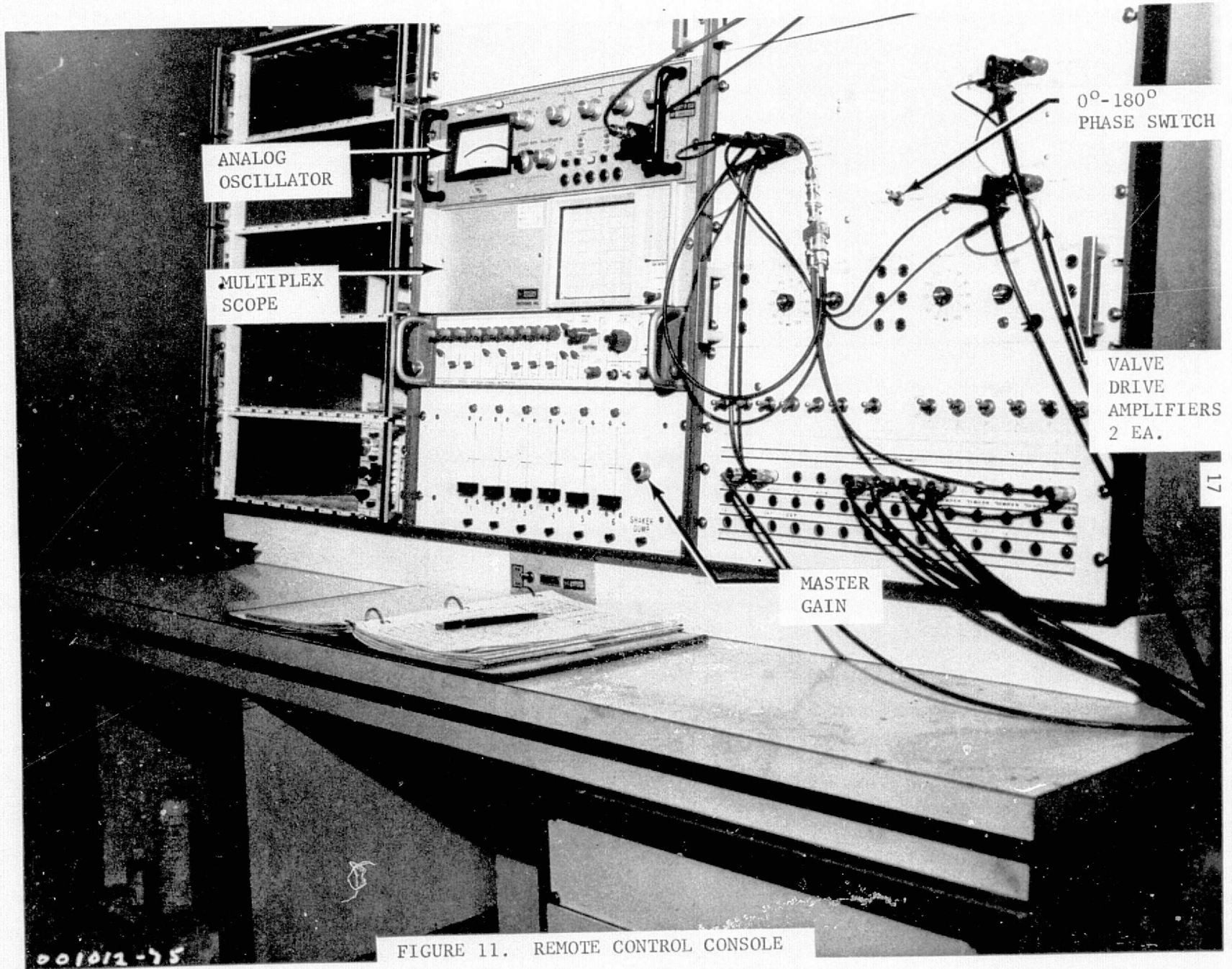
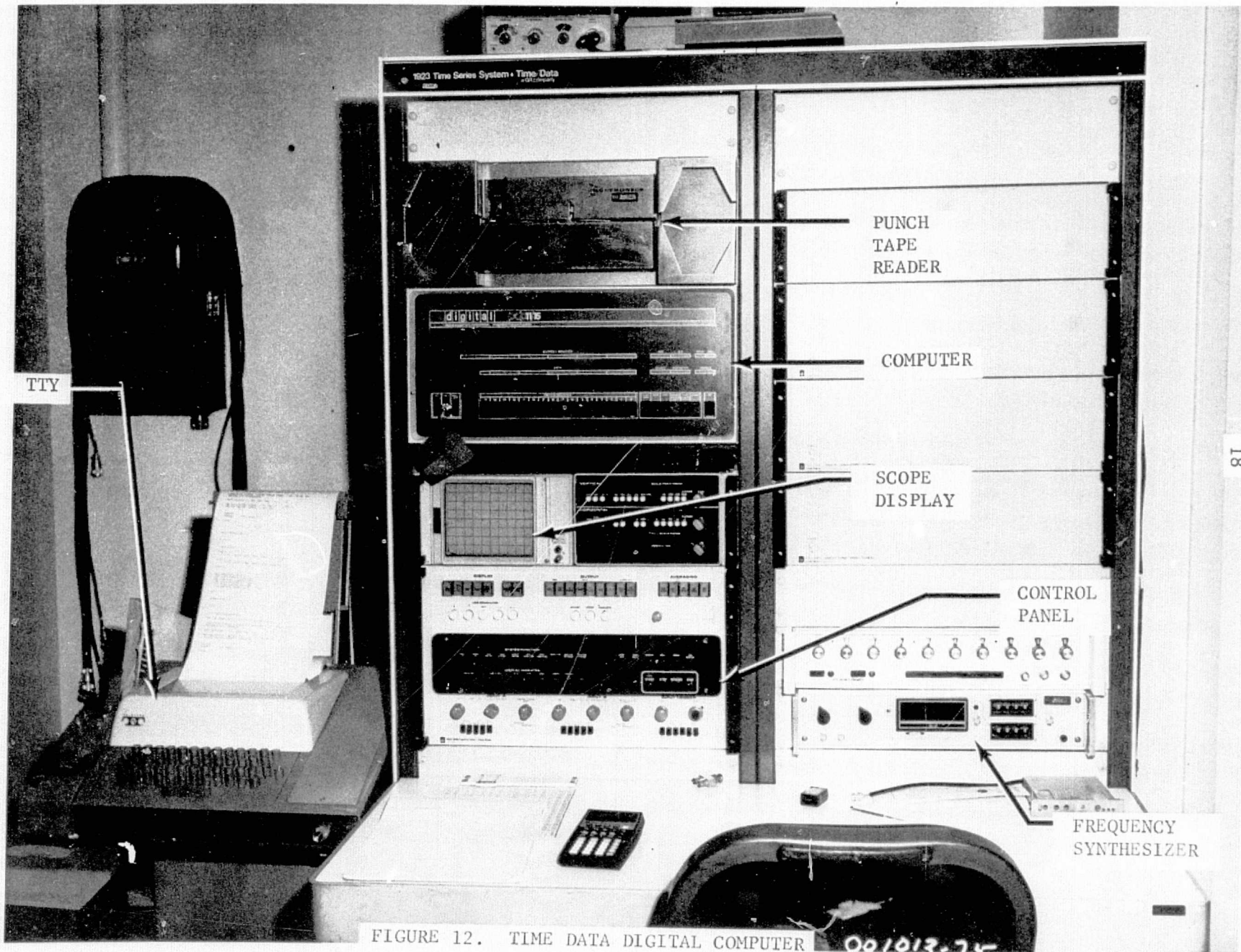

FIGURE 11. REMOTE CONTROL CONSOLE



DE-MUX
SYSTEM

MULTI PLEX
SYSTEM

TAPE DECK

TAPE DECK FIGURE 13. 100 CHANNEL TAPE RECORDER SYSTEM

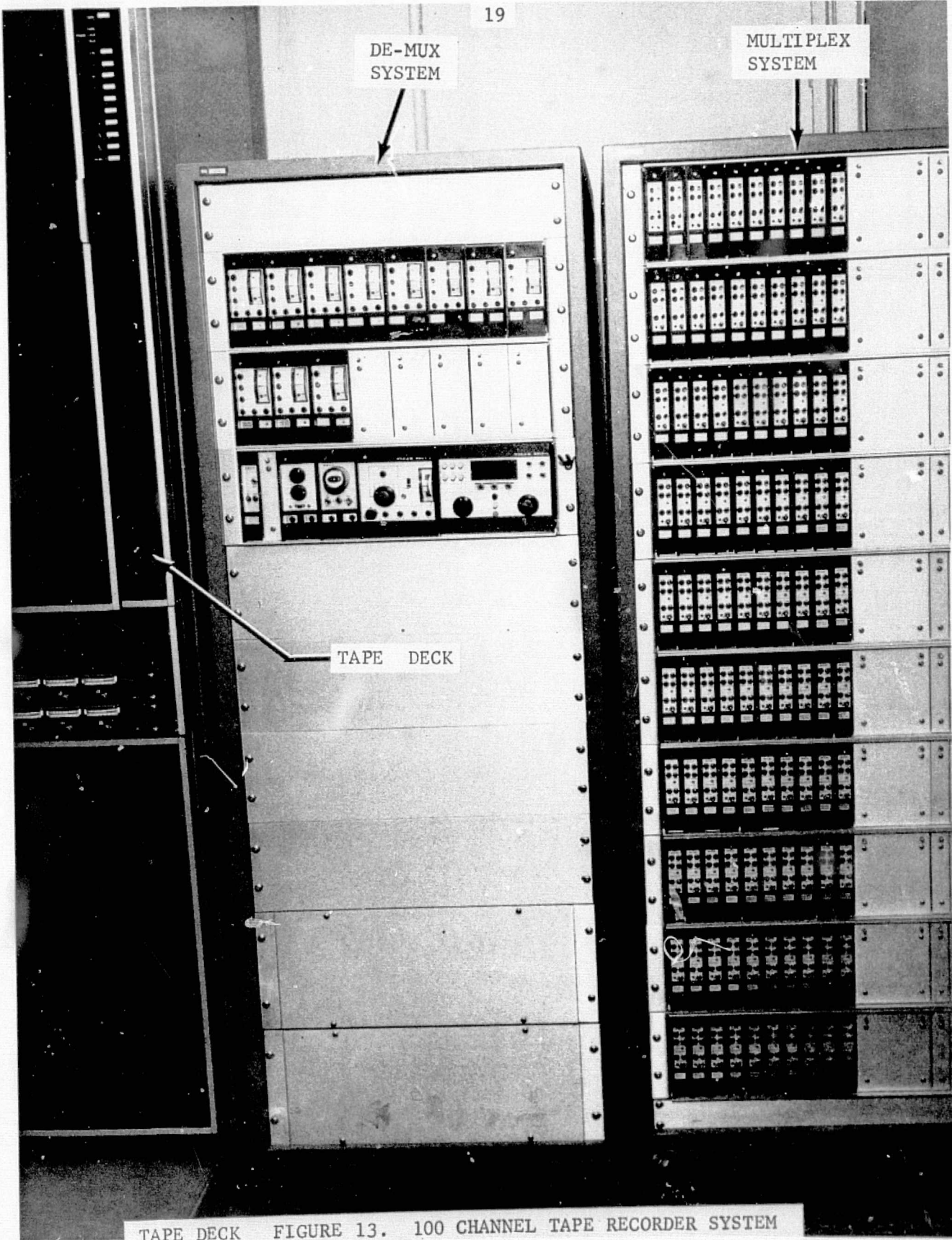

ORIGINAL PAGE IS
OF POOR QUALITY

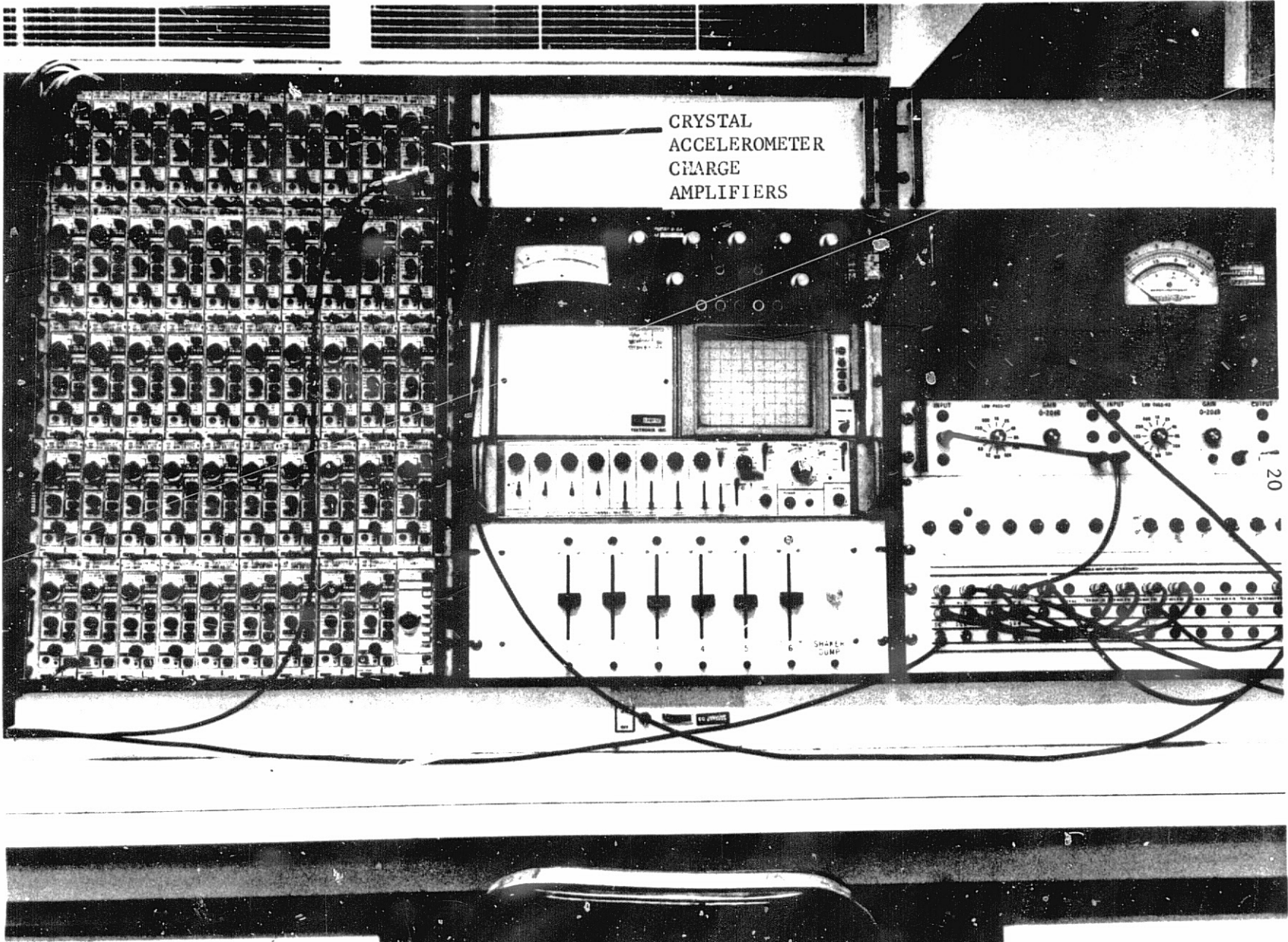

FIGURE 14. CRYSTAL ACCELEROMETER CHARGE AMPLIFIERS

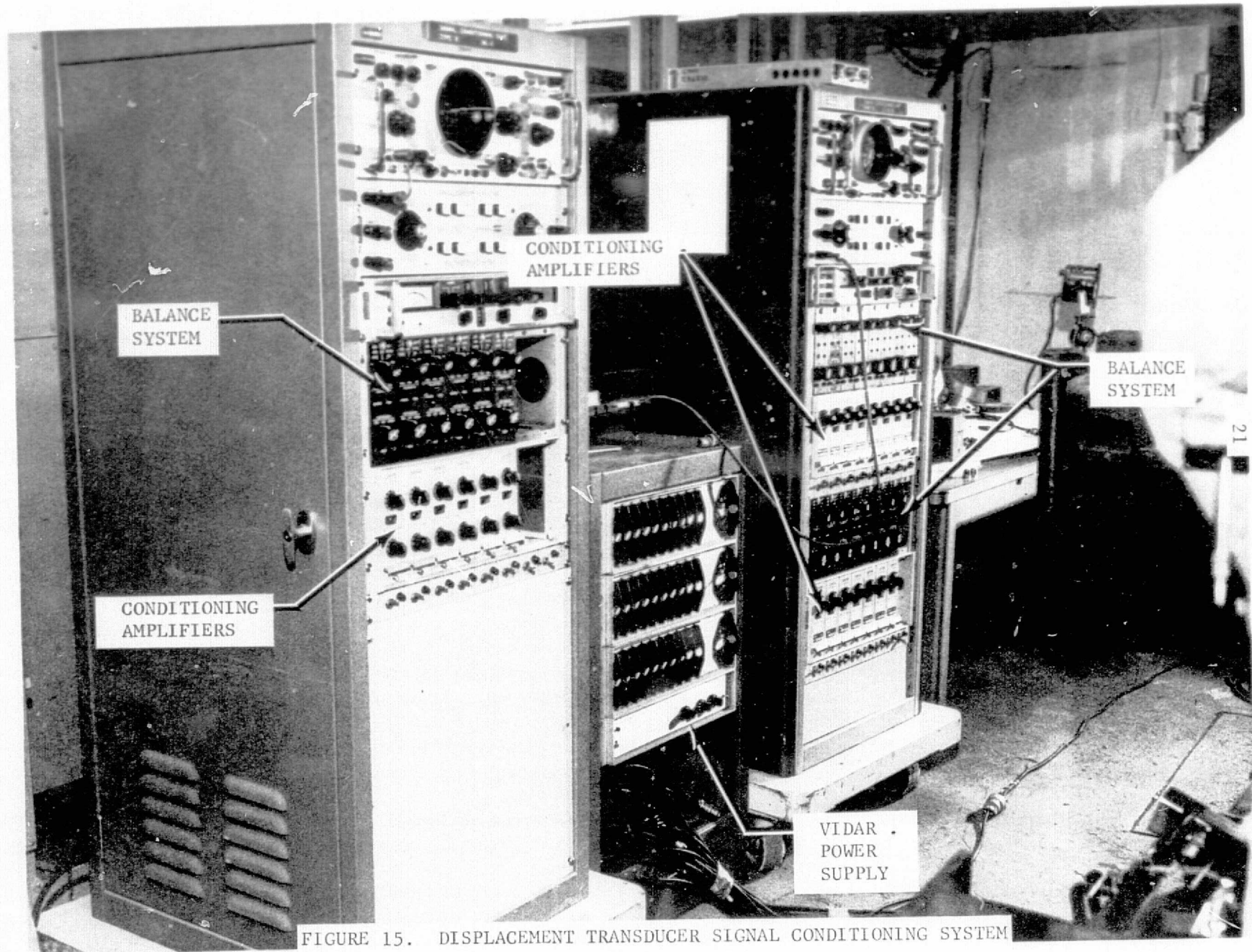
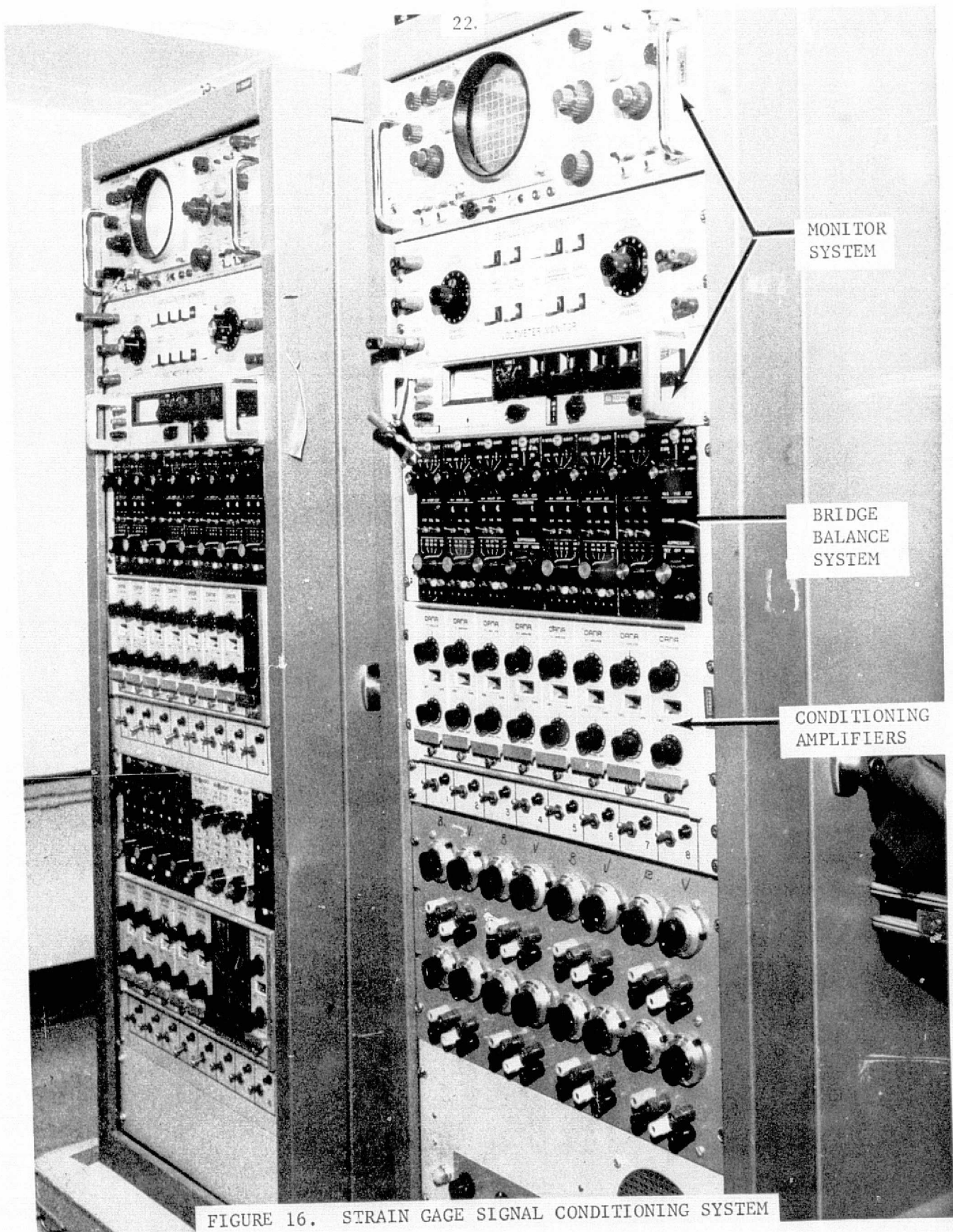

FIGURE 15. DISPLACEMENT TRANSDUCER SIGNAL CONDITIONING SYSTEM



22.

MONITOR SYSTEM

BRIDGE BALANCE SYSTEM

CONDITIONING AMPLIFIERS

FIGURE 16. STRAIN GAGE SIGNAL CONDITIONING SYSTEM

ORIGINAL PAGE IS
OF POOR QUALITY

67

ERRATA

MARTIN MARIETTA Test Report TR-005-TF

TRACK/TRAIN DYNAMICS TEST REPORT
TRANSFER FUNCTION TEST

Volume I

Text

By: R. A. Vigil

30 May 1975

Volume I: The last paragraph in section 3.2 should refer the reader
Page 2 to Figures 1 through 9 instead of 1 through 6.

Volume I: Sections 3.3.3, 3.3.4 and 3.3.5 should refer the reader to
Page 3 figures 10, 11 and 12, and 13 through 16 respectively
instead of 7, 8 and 9, and 10 through 13.

Volume I: Section 3.4.2 should refer the reader to Appendix B, Table
Page 4 8.6 instead of Appendix B, Table 8.0.

Issue date: 6/27/75

TABLE I. TRACK/TRAIN TRANSFER FUNCTION TEST SUMMARY

TEST SEQUENCE	RUN NO.	TEST REFERENCE	TEST INPUT SPECTRUM	TEST FREQ. (HZ)	SWEEP RATE (CT/MIN)	ACTUATOR PHASE (°)	TEST DATE	DATA REFERENCE	REMARKS
1) Y-Axis Tests	1) 1	1) Reqmts. Doc. IS-005-TF Test Procedure TP-005-TF	1) 6 dB/Oct 0.5-1.98 Hz, 2000 lbs-pk 1.98-35 Hz	1) 0.5-35	1) 2	1) 180°	1) 3/12/75	1) Data Not Included	1) Tests Conducted to Normal Completion.
2)	2) 2,3	2)	2) 6 dB/Oct 0.5-1.98 Hz 5000 lbs-pk 1.98-35 Hz	2)	2)	2)	2)	2)	2) Lost Data On Meas. AL3-AL12 During Run No. 2; Tests Conducted to Normal Completion.
3)	3) 4,5	3)	3) 6 dB/Oct 0.5-1.98 Hz, 10,000 lbs-pk 1.98-35 Hz	3) 0.5-21.756 0.5-23.27	3)	3)	3)	3)	3) Runs 4&5 Aborted @ 21.756&23.27 Hz On Max. Drive Limit; Stiffened Fix. Following Run 5.
4)	4) 6	4)	4) 5000 lbs-pk 0.5-50 Hz	4) 0.5-26.15	4)	4)	4) 3/18/75	4) Data In Vol. II	4) Aborted @ 26.15 Hz On 3 dB Control Limit.
5)	5) 7	5)	5) 10,000 lbs-pk 0.5-50 Hz	5) 0.5	5)	5)	5)	5) Data Not Included	5) Aborted @ 0.5 Hz On Max. Drive Limit.
6)	6) 8	6)	6) 6 dB/Oct 0.5-1.98 Hz, 10,000 lbs-pk 1.98-50 Hz	6) 0.5-2.361	6)	6)	6)	6)	6) Aborted @ 2.361 Hz On Max. Drive Limit.
7)	7) 9	7)	7) 6 dB/Oct 0.5-1.98 Hz, 7070 lbs-pk 1.89-50 Hz	7) 0.5-23.75	7)	7)	7)	7) Data In Vol. II	7) Aborted @ 23.75 Hz On 3 dB Control Limit.
8)	8) 10	8)	8) 12 dB/Oct 0.5-1.3 Hz, 9000 lbs-pk 1.3-50 Hz	8) 0.5-0.704	8)	8)	8) 3/19/75	8) Data Not Included	8) Aborted @ 0.704 Hz On 3 dB Control Limit.
9)	9) 11,12	9)	9) 4500 lbs-pk 0.5-0.919 Hz, 12 dB/Oct 0.919-1.3 Hz, 9000 lbs-pk 1.3-50 Hz	9) 0.5-1.209& 0.5-1.328	9)	9)	9)	9)	9) Run 11&12 Aborted @ 1.209&1.328 Hz On 3 dB Control Limit.
10)	10) 13	10)	10) 6000 lbs-pk @ 0.5 Hz, Linear Rise to 1.3 Hz, 9000 lbs-pk 1.3-50 Hz	10) 0.5-37.95	10)	10)	10)	10) Data in Vol. II	10) Aborted @ 37.95 Hz On Max. Drive Limit.
11)	11) 14	11)	11) 3010 lbs-pk @ 0.5 Hz, Linear Rise to 1.3 Hz, 4510 lbs-pk 1.3-50 Hz	11) 0.5-26.68	11)	11)	11)	11)	11) Aborted @ 26.68 Hz On 4 dB Control Limit.
12)	12) 15	12)	12) Same as Run 14	12) 0.5-25.79	12)	12) 0°	12)	12) Data In Vol. III	12) Aborted @ 25.79 Hz On 4 dB Control Limit.
13)	13) 16,17	13)	13) Same as Run 13	13) 0.5-0.6336 0.5-1.254	13)	13)	13)	13) Data Not Included	13) Run 16&17 Aborted @ 0.6336&1.254 Hz On 4 dB Control Limit & Stop Button Respectively.
14)	14) 18	14)	14) 4250 lbs-pk @ 0.5 Hz, Linear Rise to 1.3 Hz, 6370 lbs-pk 1.3-50 Hz	14) 0.5-32.14	14)	14)	14)	14) Data In Vol. III	14) Aborted @ 32.14 Hz On Max. Drive Limit.
15)	15) 19	15)	15) 5350 lbs-pk @ 0.5 Hz, Linear Rise to 1.3 Hz, 8020 lbs-pk 1.3-50 Hz	15) 0.5-26.9	15)	15)	15)	15)	15) Aborted @ 26.9 Hz On Max. Drive Limit.
16)	16) 20,21	16)	16) Same as Run 19	16) 0.5-27.396 0.5-27.34	16)	16)	16) 3/20/75	16) Run 20 Data In Vol. III	16) Run 20&21 Aborted @ 27.396&27.34 On Max. Drive Limit.
17)	17) 22	17)	17) Same as Run 13	17) 0.5-2.104	17)	17) 180°	17)	17) Data Not Included	17) Aborted @ 2.104 Hz On Max. Drive Limit.
18)	18) 23	18)	18) Same as Run 19	18) 0.5-34.93	18)	18)	18)	18) Data In Vol. II	18) Aborted @ 34.93 Hz On Max. Drive Limit.
19)	19) 24	19)	19) Same as Run 19	19) 0.5-1.403	19)	19) 0°	19)	19) Data Not Included	19) Aborted @ 1.403 Hz On Max. Drive Limit.
20)	20) 25	20)	20) Same as Run 18	20) 0.5-7.844	20)	20)	20)	20)	20) Aborted @ 7.844 Hz On Stop Button.

CONTINUED

ORIGINAL PAGE IS OF POOR QUALITY

TABLE I. TRACK/TRAIN TRANSFER FUNCTION TEST SUMMARY (CONTINUED)

TEST SEQUENCE	RUN NO.	TEST REFERENCE	TEST INPUT SPECTRUM	TEST FREQ. (HZ)	SWEEP RATE (OCT/MIN)	ACTILATOR PHASE (°)	TEST DATE	DATA REFERENCE	REMARKS
21) X-Axis Tests	21) 26	21) Reqmts. Doc. TS-005-TF Test Procedure TP-005-TF	21) 3010 lbs-pk @ 0.5 Hz, Linear Rise to 1.3 Hz, 4510 lbs-pk 1.3-50 Hz	21) 0.5-50	21) 2	21) 180°	21) 3/25/75	21) Data Not Included	21) Test Conducted to Normal Completion.
	22) 27	22)	22) 4760 lbs-pk @ 0.5 Hz, Linear Rise to 1.3 Hz, 7150 lbs-pk 1.3-50 Hz	22) 0.5-1.606	22)	22)	22)	22)	22) Aborted @ 1.606 Hz On Max. Drive Limit.
	23) 28	23)	23) 4500 lbs-pk @ 0.5 Hz, Linear Rise to 1.3 Hz, 6750 lbs-pk 1.3-50 Hz	23) 0.5-3.226	23)	23)	23)	23)	23) Aborted @ 3.226 Hz On Max. Drive Limit.
	24) 29	24)	24) Same as Run 18	24) 0.5-21.59	24)	24)	24)	24)	24) Aborted @ 21.59 Hz On Max. Drive Limit.
	25) 30	25)	25) 4610 lbs-pk @ 0.5 Hz, Linear Rise to 1.3 Hz, 6010 lbs-pk 1.3-50 Hz	25) 0.5-36.99	25)	25)	25) 3/26/75	25) Data In Vol. IV	25) Aborted @ 36.99 Hz On Max. Drive Limit.
	26) 31	26)	26) Same as Run 26	26) 0.5-2.088	26)	26) 0°	26)	26) Data Not Included	26) Aborted @ 2.088 Hz On 6 dB Control Limit.
	27) 32	27)	27) 2680 lbs-pk @ 0.5 Hz, Linear Rise to 1.3 Hz, 4020 lbs-pk 1.3-50 Hz	27) 0.5-2.026	27)	27)	27)	27)	27) Aborted @ 2.026 Hz On 4 dB Control Limit.
	28) 33	28)	28) 1691 lbs-pk @ 0.5 Hz, Linear Rise to 1.3 Hz, 2540 lbs-pk 1.3-50 Hz	28) 0.5-25.98	28)	28)	28)	28)	28) Aborted @ 25.98 Hz On 3 dB Control Limit.
29) Z-Axis Tests	29) 34, 35	29)	29) 5010 lbs-pk 0.5-50 Hz	29) 0.5 & 0.5-1.244	29)	29) N/A	29) 3/28/75	29)	29) Run 34&35 Aborted @ 0.5&1.244 Hz On Max. Drive Limit & 3 dB Control Limit Respectively.
	30) 36	30)	30) 2500 lbs-pk 0.5-3 Hz, 12 dB/Oct 3-4.2 Hz, 5000 lbs-pk 4.2-50 Hz	30) 0.5-1.411	30)	30)	30)	30)	30) Aborted @ 1.411 Hz On 3 dB Control Limit.
	31) 37	31)	31) 1990 lbs-pk 0.5-3 Hz, 12 dB/Oct 3-4.76 Hz, 5000 lbs-pk 4.76-50 Hz	31) 0.5-1.425	31)	31)	31)	31)	31) Aborted @ 1.425 Hz On 3 dB Control Limit.
	32) 38-40	32)	32) 500 lbs-pk 0.5-3 Hz, 12 dB/Oct 3-9.49 Hz, 5000 lbs-pk 9.49-50 Hz	32) 0.5-0.737, 0.5-4.014& 0.5-3.864	32)	32)	32)	32)	32) Run 38, 39&40 Aborted @ 0.737, 4.014&3.864 Hz On 3 dB Control Limit. Force Was Zeroed Prior to Run 39 & Force Sensitivity Was Changed Prior to Run 40.
	33) 41	33)	33) 2000 lbs-pk 0.5-50 Hz	33) 0.5-1.318	33)	33)	33)	33)	33) Aborted @ 1.318 Hz On 3 dB Control Limit.
	34) 42, 43	34)	34) 1000 lbs-pk 0.5-50 Hz	34) 0.5-0.542& 0.5-0.986	34)	34)	34)	34)	34) Run 42&43 Aborted @ 0.542&0.986 Hz On 3 dB Control Limit.
	35) 44	35)	35) 2000 lbs-pk 0.5 Hz, Linear Rise to 5 Hz, 3980 lbs-pk 5-50 Hz	35) 0.5-32.26	35)	35)	35) 3/31/75	35)	35) Aborted @ 32.26 Hz On 4 dB Control Limit.
	36) 45	36)	36) 3540 lbs-pk 0.5 Hz, Linear Rise to 5 Hz, 5010 lbs-pk 5-50 Hz	36) 0.5-27.29	36)	36)	36)	36)	36) Aborted @ 27.29 Hz On 4 dB Control Limit.
	37) 46	37)	37) 5010 lbs-pk 0.5-50 Hz	37) 0.5-27.58	37)	37)	37)	37) Data In Vol. IV	37) Aborted @ 27.58 Hz On 4 dB Control Limit.

ORIGINAL PAGE IS OF POOR QUALITY

TABLE II. DATA SUMMARY

Meas. No.	Units	Run No. 9									
		1.4 HZ	2.1 HZ	2.3 HZ	2.9 HZ	3.3 HZ	3.7 HZ	4.6 HZ	5.2 HZ		
FL1/OSC	lbs	4,394	5,371	5,859	6,347	7,324	7,324	6,347	6,347	E + 00	
FL2	↓	4,882	6,347	7,324	7,324	6,347	5,371	5,859	6,347		
FL2/FL1	lbs/lb	1.04	1.22	1.15	1.2	.92	.8	.9	.9		
FV2	↓					0.49	0.49				
FV3	↓	1.12							0.65	↓	
DV1	in/lb			1.7			1.2			E - 06	
DV2	↓			0.5			0.8				
DV3	↓	2.2	1.3			1.2			2.7		
DV4	↓	2.5	0.8			1.7			2.2		
AV3	G/lb				11.3						
AV5	↓				8.0						
AL3	↓				4.3	4.7					
AL6	↓	33.3	53.3	66.7	66.7	46.7	43.3	80.0	66.7		
AL11	↓	33.3	40.0	66.7	53.3	20.0	46.7	53.3	66.7		
AL4	↓	26.7	33.3	46.7	53.3	46.7	33.3	53.3			
AL5	↓	73.3	66.7		66.7		93.3	80.0	146.7		
AL8	↓	40.0	73.3	73.3	66.7	66.7	66.7	60.0	80.0		
AL9	↓			60.0	86.7	93.3		106.7	86.7		
AL10	↓	16.7	13.3		36.7	30.0	33.3				
AL12	↓	40.0		40.0	50.0	40.0	53.3	60.0	53.3		
DL1	in/lb				28.0			11.3			
DL2	↓				31.7			11.7			
DL3	↓				12.3			4.3			
DL4	↓			1.7	1.7				0.7		
DL5	↓				0.7		1.3				
DL6	↓			1.3	1.0						
DL7	↓						0.7				
DL8	↓	2.0	5.3	5.3	5.0	5.0	4.7	4.3	3.0		
DL9	↓	1.7	6.3	7.3	6.7	6.7	5.7	5.0	5.0		
DL10	↓		3.3	4.3	4.7	4.3	3.3	3.0	2.3		
DL11	↓	2.0	5.0	5.3	5.0	5.0	4.3	4.0	3.0		
DL12	↓		2.3				2.0				
DL13	↓			2.0							
DL14	↓		7.3	7.3	6.7				4.7		
DL15	↓		6.0	5.3	5.7				4.0		
DL16	↓		17.7	19.0		17.3		14.7			
DL17	↓		21.6	22.3		20.3		17.7		↓	

TABLE II. DATA SUMMARY

MEAS. NO.	UNITS	RUN NO. 13									
		1.28 Hz	2.08 Hz	2.72 Hz	3.2 Hz	4.8 Hz	5.76Hz	6.4 Hz	6.72Hz		
FL1/OSC	lbs	6,152	5,859	5,664	7,812	6,836	7,324	6,250	8,007	E+00	
FL2	↓	5,859	7,031	8,007	6,836	5,859	5,468	4,687	5,664		
FL2/FL1	lbs/lb	1.03	1.26	1.24	0.8	0.82	0.7	0.7	0.6		
FV2	↓	0.8			0.53			0.53			
FV3	↓	0.73								↓	
DV3	in/lb	2.7				1.3				E-06	
DV4	↓	3.0			1.0	1.0					
AV1	G/lb					9.3	12.7		14.7		
AV2					2.0		6.0		10.0		
AV3					6.7				7.3		
AV4					3.3	10.0	13.3		14.0		
AV5					3.3		6.7		6.7		
AV6					6.7						
AL1					9.3		12.0		9.3		
AL2					2.7		8.7		16.0		
AL3					3.3						
AL6							66.7				
AL7					8.0		13.3		13.3		
AL11	↓		40.0	46.7						↓	
Δ P	psi/lb	0.21	0.21	0.2	0.21	0.21	0.12	0.16	0.23	E+00	
AL4	G/lb		33.3	53.3		46.7	53.3	53.3		E-06	
AL8	↓		46.7	53.3				80.0			
AL9	↓			53.3							
AL10	↓			46.7							
DL1	in/lb			36.7							
DL2	↓			40.0							
DL3	↓			15.7							
DL4	↓		1.0					1.2			
DL5	↓			1.3		1.3	1.0	1.3			
DL6	↓		1.0								
DL7	↓						0.5				
DL8	↓			5.0							
DL9	↓			6.7							
DL10	↓			4.0							
DL11	↓			5.3							
DL12	↓			1.7							
DL13	↓			2.0						↓	

TABLE II DATA SUMMARY

MEAS. NO.	UNITS	RUN NO. 14									
		1.25 Hz	2.12 Hz	2.75 Hz	3.25 Hz	4.75 Hz	5.75 Hz	6.38 Hz	6.75 Hz		
FL1/OSC	lbs	4,394	4,394	3,906	3,906	3,906	4,394	3,418	4,394	E+00	
FL2	↓	4,394	4,882	4,394	4,394	3,906	4,394	3,906	4,394		
FL2/FL1	lbs/lb	1.0	1.1	1.1	1.2	1.0	0.95	1.2	1.26		
FV2	↓	0.8			0.6			0.7	0.8		
FV3	↓	0.9			1.0	1.0					↓
DV3	in/lb	2.0				.07			.07	E-06	
DV4	↓	2.7			0.3	.07			.07		
AV1	G/lb					3.3	3.3	6.0	4.0		
AV2					0.7		0.7		0.7		
AV3					2.7				3.3		
AV4					0.7	4.0	4.0		8.7		
AV5					0.7		0.7		3.3		
AV6					2.0						
AL1					2.7		5.3		6.7		
AL2					0.7		1.3		4.0		
AL3					1.3						
AL6							13.3				
AL7					2.7		3.3		6.0		
AL11	↓	3.3	6.7					20.0	23.3		↓
Δ P	psi/lb	0.25	0.27	0.27	0.27	0.23	0.23	0.27	0.28	E+00	
AL4	G/lb		6.7	6.7		13.3	13.3	20.0		E-06	
AL5		13.3				13.3		20.0	20.0		
AL8		13.3	20.0			13.3		26.7	23.3		
AL9		6.7	6.7	6.7	6.7				20.0		
AL10	↓			6.7							
DL1	in/lb		6.7	6.7							
DL2			0.5	1.0							
DL3			0.2	0.3							
DL4			0.3		0.7			0.3			
DL5				0.3		0.3	0.7	0.3			
DL6			0.3			0.3					
DL7							0.7				
DL8			0.8	0.67							
DL9				1.0				1.7			
DL10				0.2							
DL11				1.0					1.0		
DL12	↓			0.2							↓

31
TABLE II. DATA SUMMARY

MEAS. NO.	UNITS	RUN NO. 23							
		1.28 Hz	1.76Hz	2.08 Hz	2.4 Hz	3.84 Hz	4.96 Hz		
FL1/OSG	lbs	5,664	6,836	7,226	8,593	9,179	9,960	E+00	
FL2	↓	6,836	7,812	6,445	7,812	5,859	8,007		
FL2/FL1	lbs/lb	1.1	1.1	1.15	1.0	0.75	0.8		
FV2	↓	.61							
FV3	↓						0.8	↓	
DV1	in/lb		0.7			0.7		E-06	
DV2	↓	1.0							
DV3	↓	2.3				2.3	2.3		
DV4	↓	2.7				2.0	2.3		
AV1	G/lb						13.3		
AV2	↓						6.7		
AV3	↓					6.7			
AV4	↓						26.7		
AV5	↓				2.0		6.0		
AV6	↓					7.3			
AL1	↓				5.3		13.3		
AL2	↓						9.3		
AL3	↓					4.0			
AL6	↓				53.3				
AL7	↓				6.0		14.7		
AL11	↓				53.3			↓	
ΔP	psi/lb	0.26	0.26	0.27	0.24	0.2	0.19	E+00	
AL4	G/lb				53.3		46.7	E-06	
AL5	↓			46.7			113.3		
AL8	↓		73.3	66.7	60				
AL9	↓		53.3	60			86.7		
AL10	↓				93.3				
AL12	↓				86.7				
DL1	in/lb				50				
DL2	↓				60				
DL3	↓				46				
DL4	↓						0.7		
DL5	↓			1.7		1.3			
DL6	↓			1.0			1.0		
DL7	↓				1.0				
DL8	↓			5.0					
DL9	↓			7.0				↓	

TABLE II. DATA SUMMARY

MEAS. NO.	UNITS	RUN NO. 15									
		1.25 Hz	1.5 Hz	2.0 Hz	2.5 Hz	2.75 Hz	3.25 Hz	3.75 Hz	5.25 Hz	7.25 Hz	
FL1/OSC	lbs	4,882	4,687	3,711	5,175	4,882	4,297	4,882	4,004	2,441	E+00
FL2	↓	4,687	4,297	3,906	4,882	4,687	4,199	5,664	3,711	2,441	
FL2/FL1	lbs/lb	1.0	1.08	1.0	0.92	0.92	0.98	0.98	1.12	1.05	
FV2	↓		1.2	1.2		0.69	0.65		0.61	1.51	
FV3	↓		1.47	1.44		0.73	0.77		0.85	1.89	↓
DV1	in/lb	1.0			1.0						E-06
DV2	↓	7.0				2.2	2.2				
DV3	↓	8.8					3.7	3.7	7.0	4.0	
DV4	↓	9.8					4.0	4.0	7.5	8.2	
AV1	G/lb			5.3					53.3	56.0	
AV2	↓			8.7					22.7		
AV3	↓					17.3					
AV4	↓			5.3				17.3	53.3	46.7	
AV5	↓			15.3					52.0	56.0	
AV6	↓					18.0					
AL1	↓			20.0	20.0	20.0			46.7	33.3	
AL2	↓			6.7	6.7	6.7			37.3	71.3	
AL3	↓					8.7			6.7	10.7	
AL6	↓					-				-	
AL7	↓			16.7	16.7	16.7			50.0	50.0	↓
Δ P	psi/lb	0.24	0.25	0.23	0.22	0.24	0.23	0.25	0.26	0.23	E+00
AL4	G/lb					-				-	E-06
AL5	↓			16.7	16.7	16.7			46.7	49.3	
AL8	↓					16.7				28.7	
AL9	↓			13.3	13.3	13.3			42.0	30.0	
DL1	in/lb			1.0							
DL2	↓			0.7							
DL3	↓			0.7							
DL4	↓				1.0						
DL5	↓				1.0						
DL6	↓				0.7						
DL7	↓				0.7						
DL8	↓			0.3	0.3						
DL14	↓	1.2			2.0						
DL15	↓	2.2			1.8						
DL16	↓		0.5		0.8						
DL17	↓		0.5		0.7						↓

TABLE II. DATA SUMMARY

MEAS. NO.	UNITS	RUN NO. 19									
		0.75 Hz	1.0 Hz	1.25 Hz	1.5 Hz	1.75 Hz	2.0 Hz	2.25 Hz	2.5 Hz	2.75 Hz	
FL1/OSC	lbs	3,515	4,687	7,519	8,983	8,983	9,277	7,617	9,374	11,132	E+00
FL2	↓	3,906	5,371	6,836	9,081	9,179	8,788	7,128	9,081	11,132	
FL2/FL1	lbs/lb	1.13	1.15	.98	1.08	1.0	1.2	.91	.93	.98	
FV2		1.81		1.33			0.77	0.8		0.75	
FV3	↓	1.16		0.88			0.53	0.53		0.53	↓
DV1	in/lb		17.7	18.8				21.7			E-06
DV2	↓		36.7					36.7			
DV3		18.7	21.7				16.0				
DV4	↓	21.3	25.0				19.7				
AV1	G/lb			11.3							
AV2				14.7			16.0				
AV3						24.0		25.0			
AV4				12.7				35.3			
AV5				11.3				22.0			
AV6							21.3	24.0			
AL1											
AL2		6.7									
AL3											
AL6											
AL7	↓				28.0						↓
Δ P	psi/lb	0.23	0.18	0.26	0.22	0.14	0.21	0.18	0.23	0.21	E+00
AL4	G/lb	13.3		7.3			7.3				E-06
AL5	↓			26.7					43.3		
AL8	↓		38.7		26.7						
AL9	↓			25.3					43.3		
DL1	in/lb	3.3	3.0		3.3						
DL2		3.0			3.7						
DL3				2.2	2.2		1.7		1.2	0.83	
DL4			2.5				8.7				
DL5			2.0				9.0				
DL6		0.7					9.5			6.2	
DL7		1.0					9.8			6.3	
DL8		.7		2.0							
DL9				2.3							
DL10						2.2					
DL11				1.5							
DL12	↓			0.8							↓

39
TABLE II. DATA SUMMARY

MEAS. NO.	UNITS	RUN NO. 20									
		0.75 Hz	1.0 Hz	1.25 Hz	1.5 Hz	1.75 Hz	2.0 Hz	2.25 Hz	2.5 Hz	2.75 Hz	
FL1/OSC	lbs	3,711	4,590	5,859	7,421	9,960	10,448	7,519	7,031	9,960	E+00
FL2		4,687	5,859	8,203	7,714	10,546	9,765	5,859	7,031	9,765	
FL2/FL1	lbs/lbs	1.25	1.1	1.2	1.0	1.0	0.95	0.85	0.95	0.95	
FV2		1.57		1.63					0.93		
FV3		2.93		2.64					1.47		
DV1	in/lb		24.7					25.3	26.7		E-06
DV2			36				26.7		27.3	28	
DV3		15.3		22.5			10.3		10		
DV4		17.3		26.3			12.3		13		
AV1	G/lb	10		13.3						43.3	
AV2				16.7						20	
AV3				16.7			23.3				
AV4		16.7		16.7			26.7		36.7		
AV5				16.7			16.7		20	23.3	
AV6				20					26.7		
AL1		16.7		40		36.7	36.7	30		40	
AL2		6.7				10	10			23.3	
AL3						10		13.3			
AL6			6.7	6.7							
AL7		16.7				36.7					
ΔP	psi/lb	0.29	0.23	0.24	0.22	0.21	0.22	0.22	0.23	0.22	E+00
AL4	G/lb	10	10		10			6.7			E-06
AL5		33.3			33.3					43.3	
AL8		16.7			13.3			13.3			
AL9			53.3		40			56.7			
DL1	in/lb	1.7			2.0						
DL2		1.3			2.3						
DL3				2.0					1.0	1.0	
DL4		2.2			7.0	7.5				8.3	
DL5		1.7			7.5	7.5				8.0	
DL6		1.0			8.3	8.0				7.7	
DL7		1.0			8.7	8.7				7.5	
DL8				2.2							
DL9				2.3							
DL10				2.3		1.7					
DL11				2.0							
DL12		0.7			0.7					0.7	

APPENDIX A

TRANSFER FUNCTION TEST REQUIREMENTS DOCUMENT
POST-TEST UPDATE*

*NOTE: paragraphs denoted with an "R" have been revised from the initial document release.

PRECEDING PAGE BLANK NOT FILMED

TS-005-TF
30 May 1975

TRACK/TRAIN DYNAMICS
TEST REQUIREMENTS DOCUMENT
TRANSFER FUNCTION TEST

Contract NAS8-29882

Prepared by:

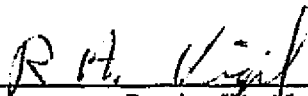

R. A. Vigil
Staff Engineer
Space Systems Dynamics

Approved by:



P. W. Abbott
Technical Director
Track/Train Dynamics

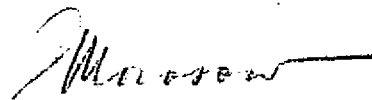

G. Morosow
Program Manager
Track/Train Dynamics

MARTIN MARIETTA CORPORATION
Denver Division
Denver, Colorado 80201

FOREWORD

This document is submitted in accordance with the requirements of NASA Contract NAS8-29882.

CONTENTS

	<u>Page</u>
Foreword	A3
Contents	A4, A5
1.0 INTRODUCTION	A6
1.1 Test Objectives	A6
2.0 DESCRIPTION OF TEST ARTICLE	A6
2.1 Test Configuration	A6
3.0 TEST LOCATION AND FACILITY DEFINITION	A6
4.0 RESPONSIBILITIES AND SUPPORT REQUIREMENTS	A7
4.1 Environmental Laboratory	A7
4.2 Structures Laboratory	A7
4.3 Dynamics	A7
4.4 Safety	A7
5.0 TEST REQUIREMENTS	A7
5.1 Test Description	A7
5.1.1 Lateral Tests	A8
5.1.2 Vertical Tests	A8
5.2 Instrumentation and Data Acquisition	A8
5.3 Data Reduction	A8
6.0 RESULTS	A9
6.1 Test Data Report	A9
6.2 Data Retention	A9

CONTENTS (continued)

	<u>Page</u>
<u>Figures</u>	
1 Test Article General Configuration	A10
2 Test Setup and Configuration	A11
3 Car Instrumentation Locations and Measurement Numbers	A12
4 Truck Instrumentation Locations and Measurement Numbers	A13
<u>Tables</u>	
I Test Measurement Summary	A14

1.0 INTRODUCTION

This document defines the detailed requirements for conducting sinusoidal vibration tests on an 80 ton open hopper railroad freight car. The test program consists of obtaining transfer function data from vertical and lateral excitation of the test article for comparison with analytical data.

1.1 Test Objective - The objective of the transfer function test is to obtain data for the validation of the freight car nonlinear elastic model.

2.0 DESCRIPTION OF TEST ARTICLE

The test article is an L&N RR model M-042-174 freight car with ASF 11 trucks. Details concerning the test article general arrangement can be found in Figure 1.

2.1 Test Configuration - The test specimen will be loaded with 80 ton of coal. One truck assembly will be supported by four individual lateral slide plates at each wheel location which will be coupled to the test floor through load cells or spacers as required. The other truck assembly will be supported such that the entire assembly is parallel with the facility floor. This test setup is illustrated in Figure 2.

3.0 TEST LOCATION AND FACILITY DEFINITION

The test will be conducted in the structural Laboratory Low Bay area

of the General Purpose Laboratory. Test support equipment will be located in the enclosure near the test setup to afford this equipment maximum protection. The necessary utilities to accommodate the test support equipment will be furnished by the test facility.

4.0 RESPONSIBILITIES AND SUPPORT REQUIREMENTS

4.1 Environmental Laboratory (0434) - Provide two hydraulic shaker systems, instrumentation, data acquisition/reduction equipment, test procedure, data report and post-test procedure update.

4.2 Structures Laboratory (0436) - Provide facility, hydraulic pump and plumbing, shaker supports, truck support and slide plates, wheel load cells, shaker load cells and attachment and displacement transducers and installation.

4.3 Dynamics (0433) - Provide pre-test analysis, test requirements document, post-test requirements document update, final test report, and analytical model validation.

4.4 Safety - Insure personnel safety.

5.0 TEST REQUIREMENTS

5.1 Test Description - Lateral excitation will be applied to the test specimen simultaneously by two 10,000 force-pound hydraulic actuators. Input force levels will be automatically controlled by peak selection between each actuator. Vertical excitation will be applied using a single actuator. Sinewave sweep tests will be conducted from

R 0.5 to 50 Hz at 2 octave/minute and at three peak force levels, 2000, 5000 and 10,000 pounds respectively. The above force levels will be limited by actuator maximum displacement and force capability (max. displ. 2" d.a., max. force approx. 10,000 pounds-peak).

R 5.1.1 Lateral Tests - Excitation will be applied separately in the (Y) direction at the axles of each wheel set and in the (X) direction at the forward axle of one truck as shown in Figure 2. Tests will be conducted with the actuators both in phase and 180° out of phase for the (Y) and (X) direction tests. During these tests, vertical wheel forces will be measured at wheel positions 1 and 2 for (Y) and 1 and 3 for (X) direction tests as shown in Figure 4.

R 5.1.2 Vertical Tests - Excitation will be applied vertically at the freight car side frame in the middle of the car body as shown in Figure 2. Tests will be conducted while monitoring vertical wheel forces at wheel positions 1 and 3, respectively (see Figure 4).

R 5.2 Instrumentation and Data Acquisition - Instrumentation locations and measurement numbers are illustrated in Figures 3 and 4 and listed in Table I. The total number of transducers which will be recorded on magnetic tape are as follows:

Force Gages (Load Cells)	4
Accelerometers	18
Displacement Transducers	21
Differential Pressure	1

In addition, movie camera coverage of truck/car motions will be required.

R 5.3 Data Reduction - Data reduction will consist of obtaining transfer function plots as required using the input force at one actuator position as a reference. Selected oscillograph data will also be required.

6.0 RESULTS

R 6.1 Test Data Report - A test data report will be issued 30 days after the completion of the data reduction. This report shall include, but not be limited to, the following:

- a. Transfer Function Plots,
- b. Photographs of the test setup and instrumentation locations,
- c. Movies of car/truck motions,
- d. Test log,
- e. Instrumentation Log Sheets (calibrations, channel and trace identification, etc.).

6.2 Data Retention - All quick look data, tapes and logs will be retained for 18 months after test completion.

ORIGINAL PAGE IS
OF POOR QUALITY

80-TON HOPPER CARS

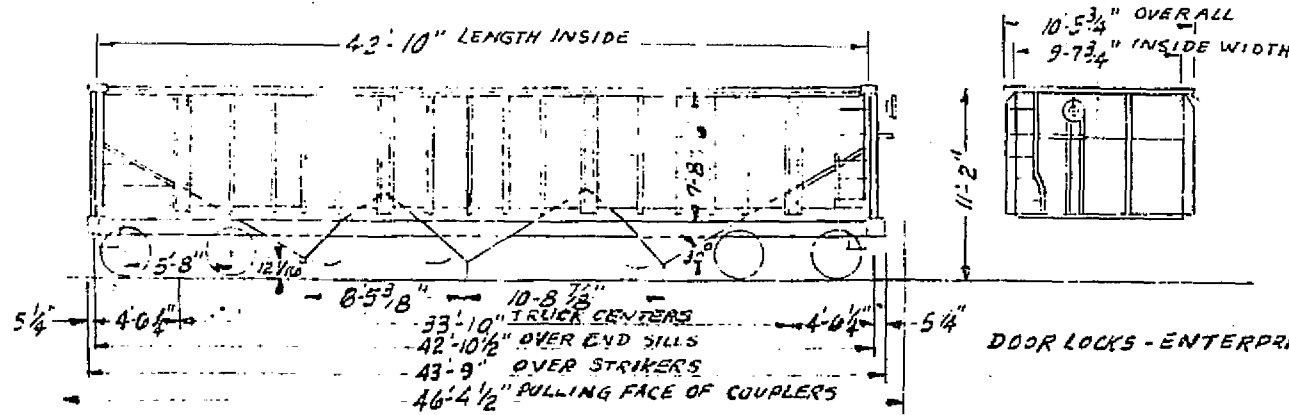

GENERAL CAR DATA		80-TON TRUCK DATA	
Gen. Arrangement M-042-174	Cap. Cu. Ft. 2960	No. 140	Type A-3
End Arrangement B-003-171	With 10' Hoop Cu. Ft. 3200	Dwg. Copy 6" x 11"	Side Bearing 650-C STOCK
AAR Class HT	Total Cap. Cu. Ft.	Wt. 8860#	Journals ROLLEP BEARINGS
LSN Equip. Code 218	Eq. End Hopper Cu. Ft.	Bowl Dia. 44"	Ped. Adapter FS-4282, E-21744
Built By P-5	Center Hopper Cu. Ft.	Wheels 33" 1-W CAST STL.	Axles 6" x 11"
Lot 9535	Floor	Side Frame FS-4294	Brake Beams #18 R.S.F. UNIT
Built or Rebr. OCT, NOV., 1971	Floor Copy	Bolster FS-4416	Brake Shoes AAR H-4-A
Taken from	Lining S. or Interior	Bowl Wear Plate	Trk. Mounted Brakes
Clearance Plate B	Lining End	Brake Wear Ring	
Curve Negotiability—with 40.5' car	No. DF Belts	Live Lever 8" x 14" 1185*	
Average H. Wt. 53,200#	No. Lading Anchors	Dead Lever 8" x 14" 1185*	
Average Ld. Lmt. 166,800#	Movable Bulkheads	Bottom Rod (UNDER) 1201-380-BX	
Center of Gravity E-46-8" L-73 9"	No. Chain Tie Downs	TRUCK SPRINGS PER TRUCK	
Air Brakes ADD-1012	Stake Pockets Per Side	Outer 10 D-5	MISCELLANEOUS
Brake Regulator UNIVERSAL 1900-G	Gates or Draw P-5	Inner 6 D-5	1. UNIVERSAL 186200-186399
Hand Brake SEE NOTE 1.	Running Bolsters	Shocks 0-0 AND D-5	KLASING 186400-186499
Chimney	Master Attachment	Shock Absorber	2. 50 CARS EQUIPPED WITH
Coupler B-EGOB-HT	Feet	Slide Control Sprgs. per Trk.	INVERTED TRUCK BOLSTERS
Eye B-YAO-HT	Roller	4 ASF DWG 54222	LETTER 1-12-73 FILE 30-2 F 208
Gate C-W MK-50	Roller Cover	Door	PATT. FS-4432.
Strake FS-4372	Drop Ends	Side	
Rack Stop & T. FS-4384	Coiled End Cradles	Friction Casting	

300 186200-186499

NO. CAPS CAP SERIES

L & N R. R. CO.
MECH. ENGINEERS OFFICE
LOUISVILLE, KY.
David Orr, Eng. Mech. Systems Dept.
L-5122, 408 W. Broadway, Louisville 40201

REVISION SHEET NO.
H-42-1

FIGURE 1. TEST ARTICLE GENERAL CONFIGURATION

A10

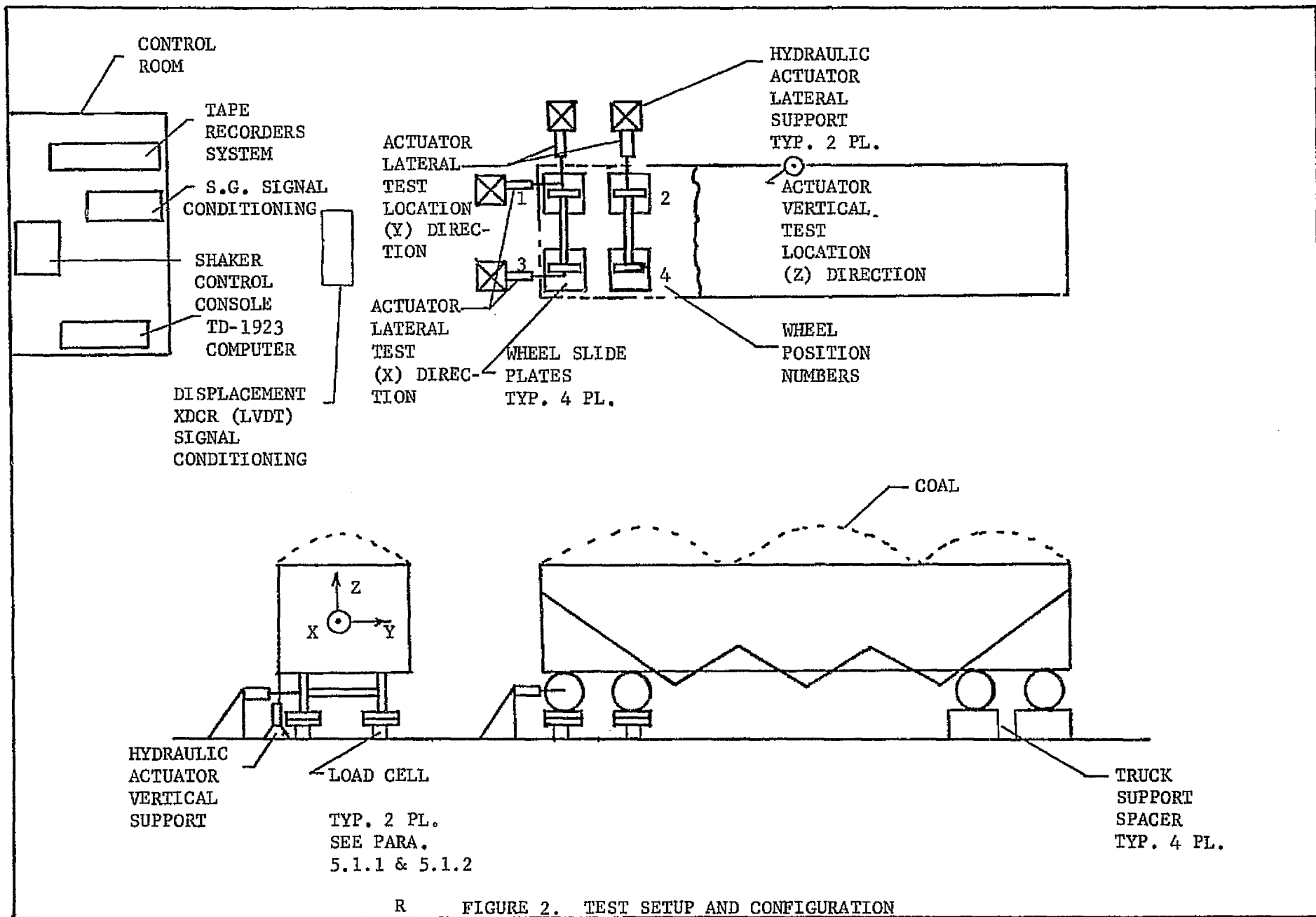

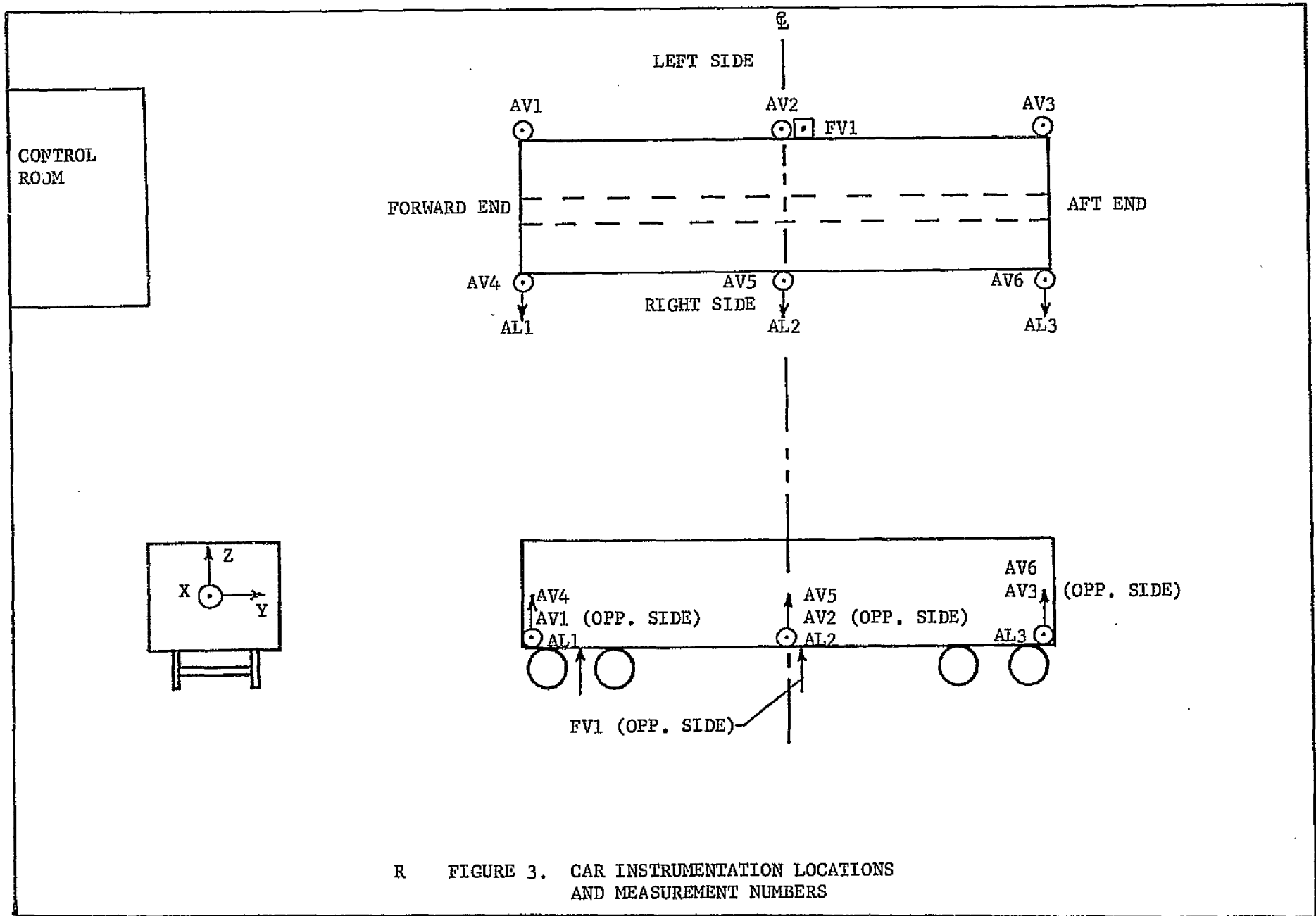

A13

FORWARD
TRUCK
ASSEMBLY

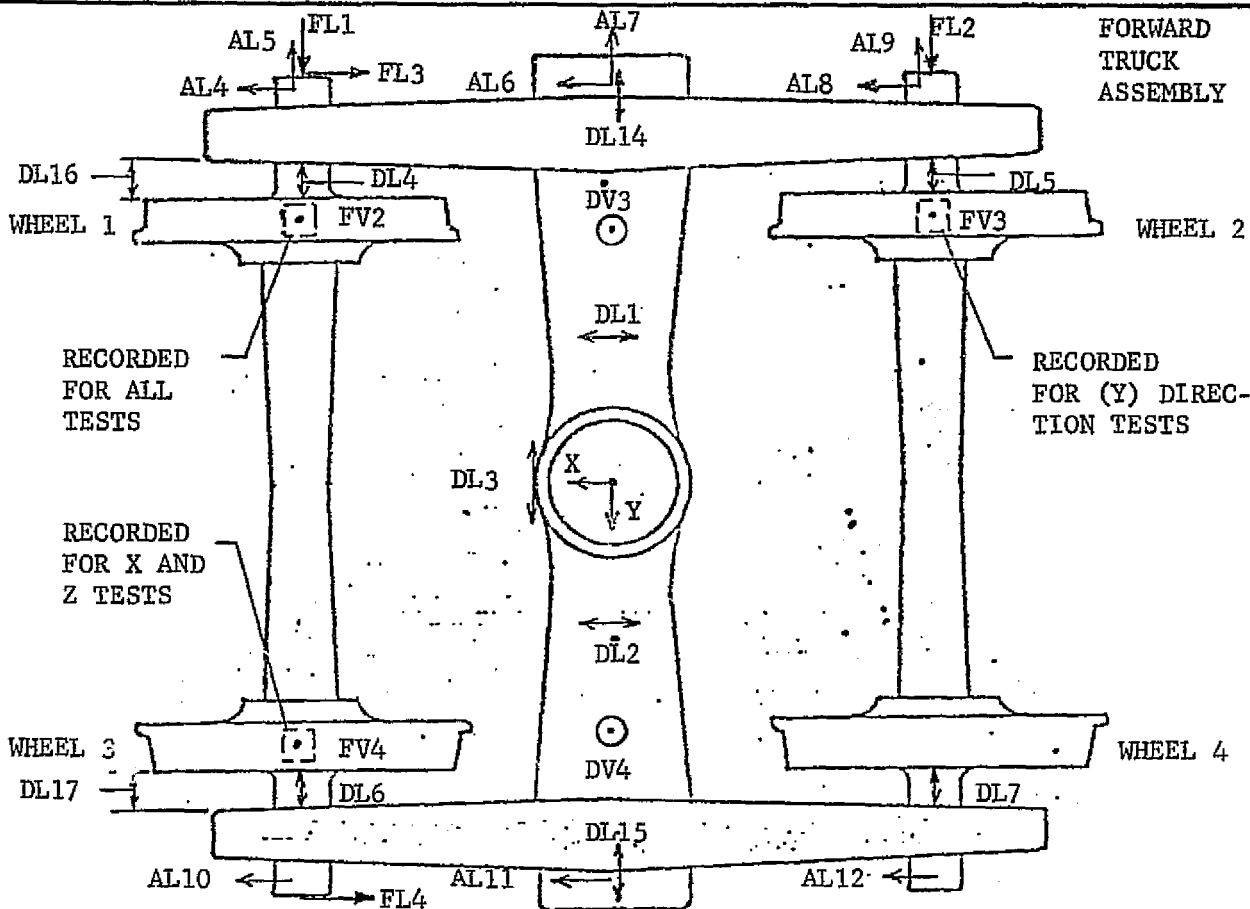

RECORDED
FOR ALL
TESTS

RECORDED
FOR (Y) DIRECTION
TESTS

RECORDED
FOR X AND
Z TESTS

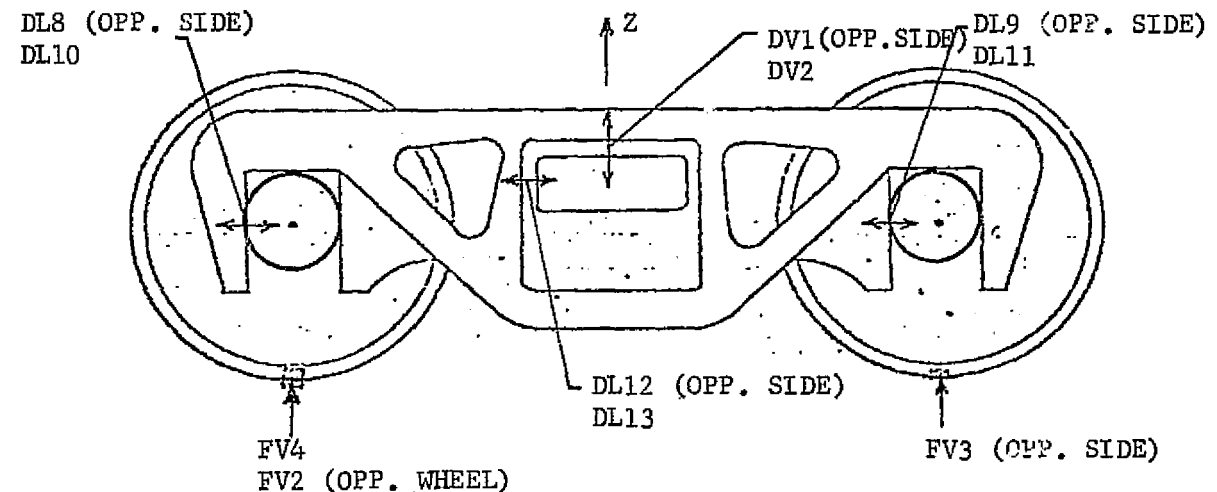

NOTES: DL1,2&3 ARE RELATIVE DISPL. OF BOLSTER WRT CAR, ALSO DV3 & DV4.
DL4 THROUGH DL11 ARE RELATIVE DISPL. OF SIDE FRAMES WRT AXLE.
DV1, DV2, DL12 & DL13 ARE RELATIVE DISPL. OF BOLSTER WRT SIDE FRAMES,
ALSO DL14 & DL15.
DL16 & DL17 ARE RELATIVE DISPL. OF SIDE FRAMES WRT WHEELS 1 & 3
RESPECTIVELY.

R FIGURE 4. TRUCK INSTRUMENTATION LOCATIONS
AND MEASUREMENT NUMBERS

APPENDIX B

TRANSFER FUNCTION TEST PROCEDURE DOCUMENT
POST-TEST UPDATE*

*NOTE: paragraphs denoted with an "R" have been revised from the initial document release.

TRACK/TRAIN DYNAMICS
TEST PROCEDURE
TRANSFER FUNCTION TEST

Contract NAS8-29882

Prepared by:

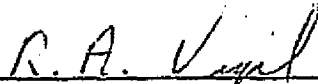

R. A. Vigil
Staff Engineer
Space Systems Dynamics

Approved by:



P. W. Abbott
Technical Director
Track/Train Dynamics



J. T. Osmanski
Section Chief
Test Data & Environmental Labs

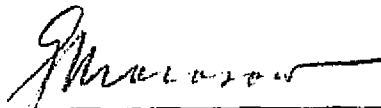

G. Morosow
Program Manager
Track/Train Dynamics

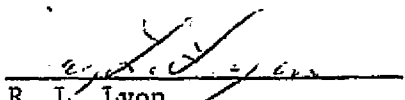

R. L. Lyon
Unit Head
Structures Laboratory

MARTIN MARIETTA CORPORATION
Denver Division
Denver, Colorado 80201

FOREWORD

This document is submitted in accordance with the requirements of NASA Contract NAS8-29882.

CONTENTS

	<u>Page</u>
Title Page	B2
Foreword	B3
Contents	B4, B5
1.0 SCOPE	B6
1.1 Objective	B6
1.2 Summary	B6
2.0 TEST CONFIGURATION	B6
3.0 SUPPORT REQUIREMENTS	B6
3.1 Handling Equipment	B6
3.2 Test Equipment	B6
3.3 Reference Documents	B6, B7
3.4 Facility Requirements	B7
4.0 SPECIAL CONSIDERATIONS	B7
4.1 Cautions and Warnings	B7
4.2 Test Discrepancies	B7
4.3 Safety	B7, B8
4.4 Procedure Changes	B8
4.5 Test Personnel	B8
4.6 Test Log	B8
4.7 Test Data	B8
4.8 Test Control Board	B8
5.0 OPERATIONS	B9
5.1 Preparations	B9,
5.2 Detailed Operations	B9, B10
5.3 Post-Test Review	B10
5.4 Post-Test Disassembly	B11
6.0 ABBREVIATIONS AND ACRONYMS	B12, B13
7.0 FIGURES	
7.1 Test Setup and Configuration	B14
7.2 Car Instrumentation Locations and Measurement Numbers	B15-B21
7.3 Truck Instrumentation Locations and Measurement Numbers	B22-B42
7.4 Test Instrumentation and Control System Block Diagram	B43
7.5 Test Fixtures	B44-B52

CONTENTS (continued)

8.0	TABLES	
8.1	Handling Equipment	B53
8.2	Test Equipment	B54
8.3	Test Measurement Summary	B55
8.4	Instrumentation Setup Sheet	B56-B58
8.5	Test Historical Log	B59-B66
8.6	Transfer Function-Deflection Coordinates	B67

1.0 SCOPE

This procedure provides the necessary information and detailed operations required to conduct the transfer function vibration test on an 80 ton open hopper freight car.

1.1 Objective - The objective of the transfer function test is to obtain data for the validation of the freight car nonlinear elastic model.

1.2 Summary - The test configuration, handling, test facilities, test operations, and data acquisition/reduction activities necessary to meet the conditions of the test requirements document (TS-005-TF) are delineated herein.

2.0 TEST CONFIGURATION

The test article will be setup as illustrated in Figure 7.1.

3.0 SUPPORT REQUIREMENTS

3.1 Handling Equipment - The support equipment necessary to move the freight car, shakers, and coal is listed in Table 8.1.

3.2 Test Equipment - The support equipment necessary to conduct the test is listed in Table 8.2.

3.3 Reference Documents -

3.3.1 P74-48338-1, "Track-Train Dynamics Analysis and Test Program," Update

3.3.2 TS-005-TF, "Track/Train Dynamics Test Requirements Document, Transfer Function Test"

3.3.3 LAB 1007302, "Track-Dynamic Analysis GVS and Transfer Function Test"

3.3.4 LAB 0212205, Sinewave Vibration Control Standard
Operating Procedure

3.3.5 1923-5017, Time/Data Sinusoidal Vibration Control
Manual

3.4 Facility Requirements -

3.4.1 115 VAC, 60 Hz, 1 \emptyset

3.4.2 440 VAC, 60 Hz, 3 \emptyset

3.4.3 Hydraulic Power Supply

4.0 SPECIAL CONSIDERATIONS

4.1 Cautions and Warnings - The description appearing within a CAUTION or WARNING precedes the information that it is intended to emphasize. A CAUTION is used to prevent personnel from damaging equipment. A WARNING is used to prevent test personnel from endangering their safety or that of others. Each step of this procedure shall be read completely before proceeding with the action.

4.2 Test Discrepancies - A test discrepancy shall be logged and reported when test performance and/or results are affected.

4.3 Safety - MMC supervision are directly responsible for the safety of all personnel, safe working conditions and the implementation of all safety requirements applicable to this procedure.

4.3.1 All test team members are responsible for adhering to normal safety standards and procedures. They are also responsible for advising of any unsafe acts or conditions observed during preparation for or during conduct of this procedure.

4.3.2 Personnel safety will be notified 24 hours prior to the official test start date. This test is classified as having non-destructive potential.

4.4 Procedure Changes - All changes to this procedure will be documented and added to a post-test procedure update.

4.5 Test Personnel

<u>Code</u>	<u>Description</u>	<u>Quantity</u>
TD	Technical Director	1
TE	Test Engineer	1
MT	Mechanical Technician	1
ET	Electronic Technician	1
SF	Safety	1

4.6 Test Log - A test log shall be maintained during the test and shall contain information for a complete historical chronological description of test activities.

4.6.1 Instrumentation setup sheets shall be maintained and form part of the test log.

4.7 Test Data - Provision shall be made to retain all test data for a period of 18 months after the test completion.

4.8 Test Control Board - A test control board (TCB) shall periodically monitor test activities and shall consist of the following personnel:

<u>Name</u>	<u>Title</u>	<u>Function</u>
G. Morosow	Project Manager (MMC)	Chairman
P. Abbott	Technical Director (MMC)	Member
J. Macpherson	Technical Representative (NASA/MSFC)	Member

STEP NO.	RESPONSIBILITY	CK	ACTION	REMARKS
5.0			OPERATIONS	
5.1			<u>Preparations</u>	
5.1.1	MT	—	Position the freight car in the facility per drawing LAB 1007302.	
5.1.2	MT	—	Install hydraulic power supply near actuator test positions.	
5.1.3	MT,ET	—	Install aft truck support, forward slide plates and load cell/spacer assemblies per LAB 1007302. Locate load cells under wheel 1 and 2 per Figure 7.3 and measure static load.	Wh. 1 - 25,939 lbs Wh. 2 - 25,755 lbs
5.1.4	MT	—	Install actuator support fixture per LAB 1007302.	
5.1.5	MT	—	Install actuators for (Y) direction tests per Figure 7.1.	
5.1.6	ET	—	Install instrumentation in the locations identified by Figures 7.2, 7.3 and Table 8.3. Record data in Table 8.4.	
5.1.7	ET/MT	—	Setup actuator system and data acquisition/reduction equipment as shown in Figure 7.1.	
5.1.8	ET/MT	—	Connect and route all interconnecting cables and plumbing per Figure 7.4.	
5.1.9	ET	—	Verify data acquisition equipment operation, tap check transducers, record full scale calibrations and log information in Table 8.4.	
5.1.10	ET	—	Load sine control program in computer and verify operation per Time/Data manual.	
5.2			<u>Detailed Operations</u>	
R 5.2.1	TE/et al	—	Perform a 2000 lb-pk sinewave sweep from 0.5 to 50 Hz controlling FL1 and FL2 per LAB 0212205 and record all data channels.	Control Abort Tol. \pm 3dB

STEP NO.	RESPONSIBILITY	CK	ACTION	REMARKS
R 5.2.2	TE/et al	—	Perform a 5000 lb-pk sine sweep from 0.5 to 50 Hz controlling FL1 and FL2 per LAB 0212205 and record data.	Limit Actuator Displ. to $\pm 2''$ D.A. & Vel. to 8.3 "/sec.
R 5.2.3	TE/et al	—	Perform a 10,000 lb-pk sine sweep from 0.5 to 50 Hz controlling FL1 and FL2 per LAB 0212205 and record data. Also, take movies of car/truck motion.	Limit Actuator Displ. to $\pm 2''$ D.A. & Vel. to 8.3 "/sec.
R 5.2.4	TE	—	Load transfer function program and plot selected data per TD.	
R 5.2.5	TE/et al	—	Load sine program and repeat steps 5.2.1 through 5.2.4 with the actuators in phase.	
5.2.6	MT	—	Photograph test setup and actuator/transducer locations.	
5.2.7	MT	—	Install actuators for (X) direction tests and vertical load cells per Figures 7.1 and 7.3.	
R 5.2.8	TE/et al	—	Repeat steps 5.2.1 through 5.2.6, except control measurements FL3 & FL4.	
5.2.9	MT	—	Photograph new actuator locations	
5.2.10	MT	—	Install a single actuator for (Z) direction tests per Figure 7.1.	
R 5.2.11	TE/et al	—	Load sine program and perform steps 5.2.1 through 5.2.4, except control measurement FV1.	
5.2.12	MT	—	Photograph actuator location.	
5.2.13	ET	—	Complete data reduction per TD.	
5.3			<u>Post-Test Review</u>	
5.3.1	TCB	—	Perform post-test review to verify test objectives & terminate test.	

STEP NO.	RESPONSIBILITY	CK	ACTION	REMARKS
5.4			<u>Post-Test Disassembly</u>	
5.4.1	MT/ET	—	Remove all instrumentation, actuators and fixturing.	
5.4.2	MT	—	Unload coal	
5.4.3	TE	—	Prepare data package containing logs, setup sheets, photographs and data.	

6.0 ABBREVIATION AND ACRONYMS

Calib.	Calibration
Cap.	Capacity
CDC	Control Data Corporation
Ch.	Channel
Ck.	Check
CO	Coincidence Component
ET	Electronic Technician
FS	Full Scale
Meas.	Measurement
Mfg.	Manufacturer
MMC	Martin Marietta Corporation
MSFC	Marshall Space Flight Center
MT	Mechanical Technician
NASA	National Aeronautics and Space Administration
No.	Number
O-Graph	Oscillograph
Osc.	Oscillator
Qty.	Quantity
QUAD	Quadrature Component
Sens.	Sensitivity
SF	Safety
SW	Switch
TCB	Test Control Board
TD	Technical Director

TE	Test Engineer
TTY	Teletype Terminal
Typ.	Typical
U-D	Unholtz-Dickie Corporation
XDCR	Transducer

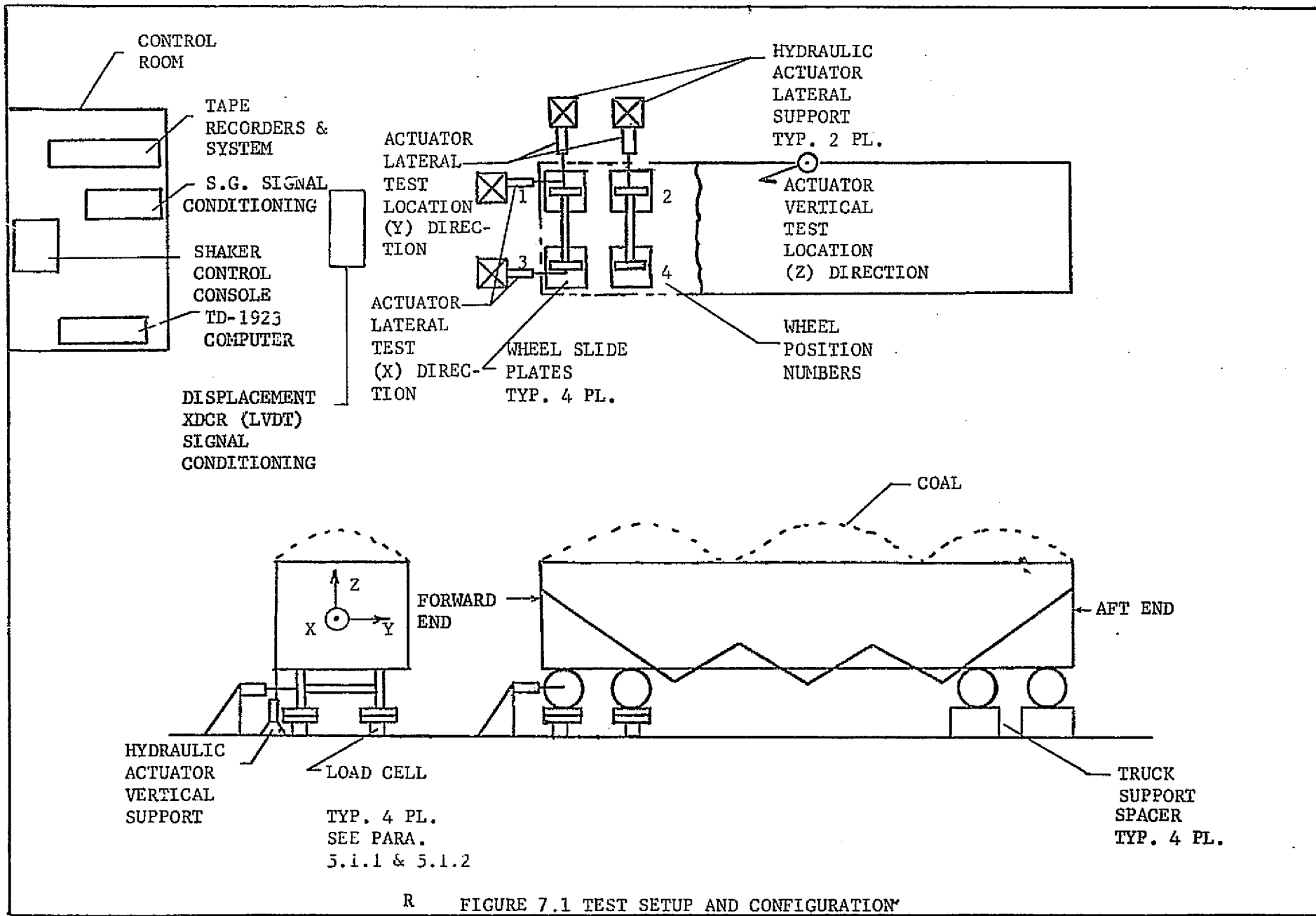

R FIGURE 7.1 TEST SETUP AND CONFIGURATION

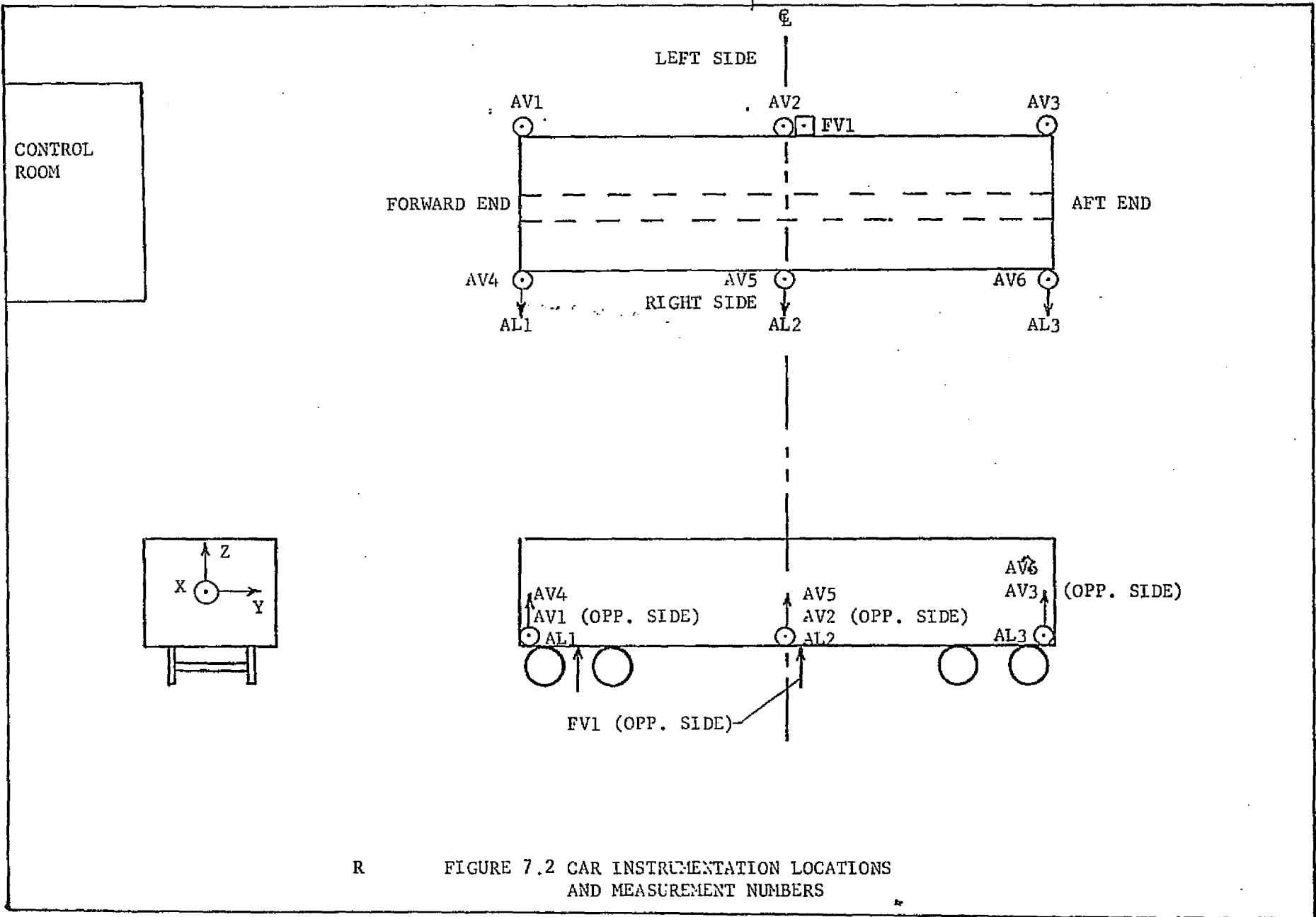

B15

R FIGURE 7.2 CAR INSTRUMENTATION LOCATIONS AND MEASUREMENT NUMBERS

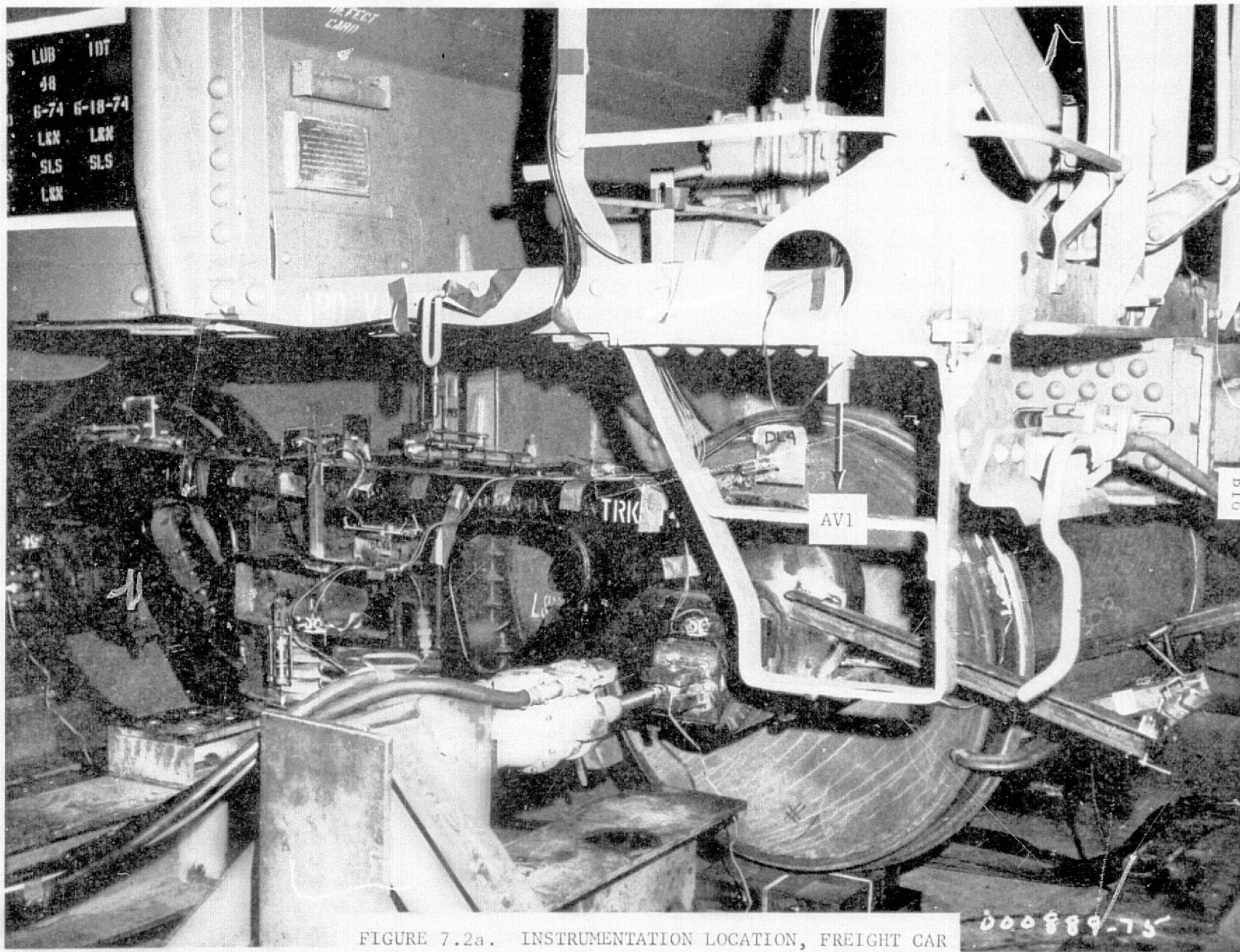

FIGURE 7.2a. INSTRUMENTATION LOCATION, FREIGHT CAR

ORIGINAL PAGE IS
OF POOR QUALITY

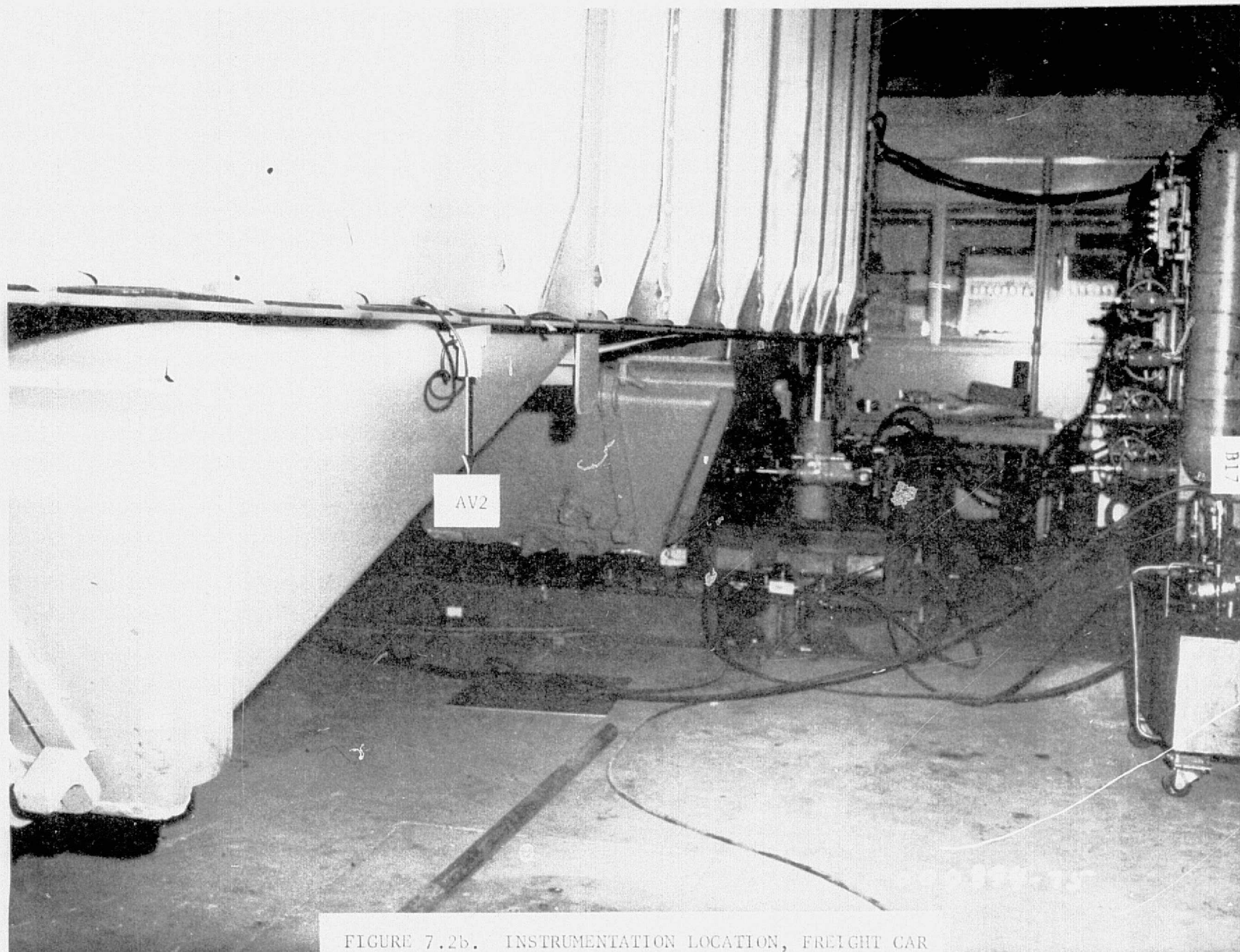

FIGURE 7.2b. INSTRUMENTATION LOCATION, FREIGHT CAR

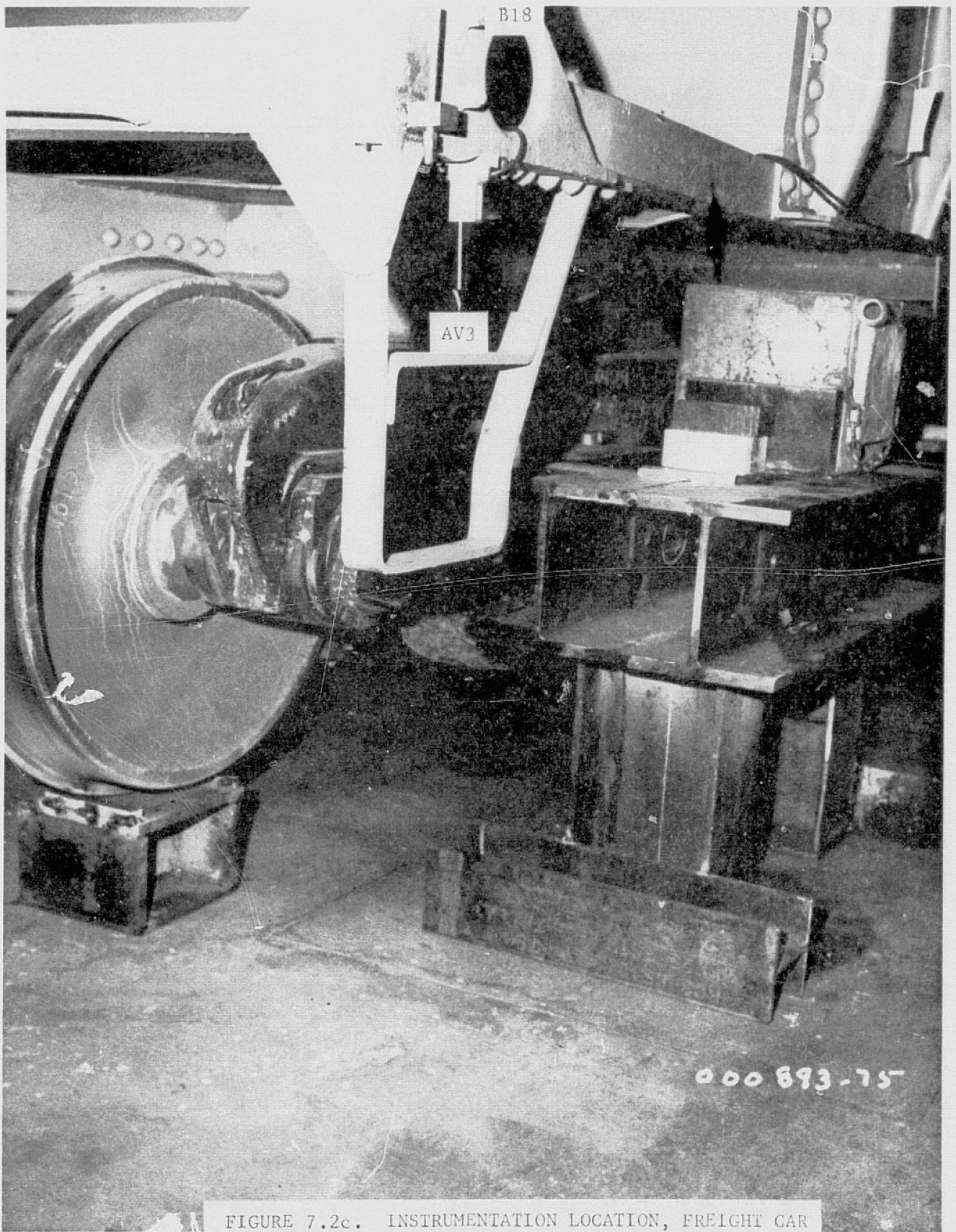

FIGURE 7.2c. INSTRUMENTATION LOCATION, FREIGHT CAR

ORIGINAL PAGE IS
OF POOR QUALITY

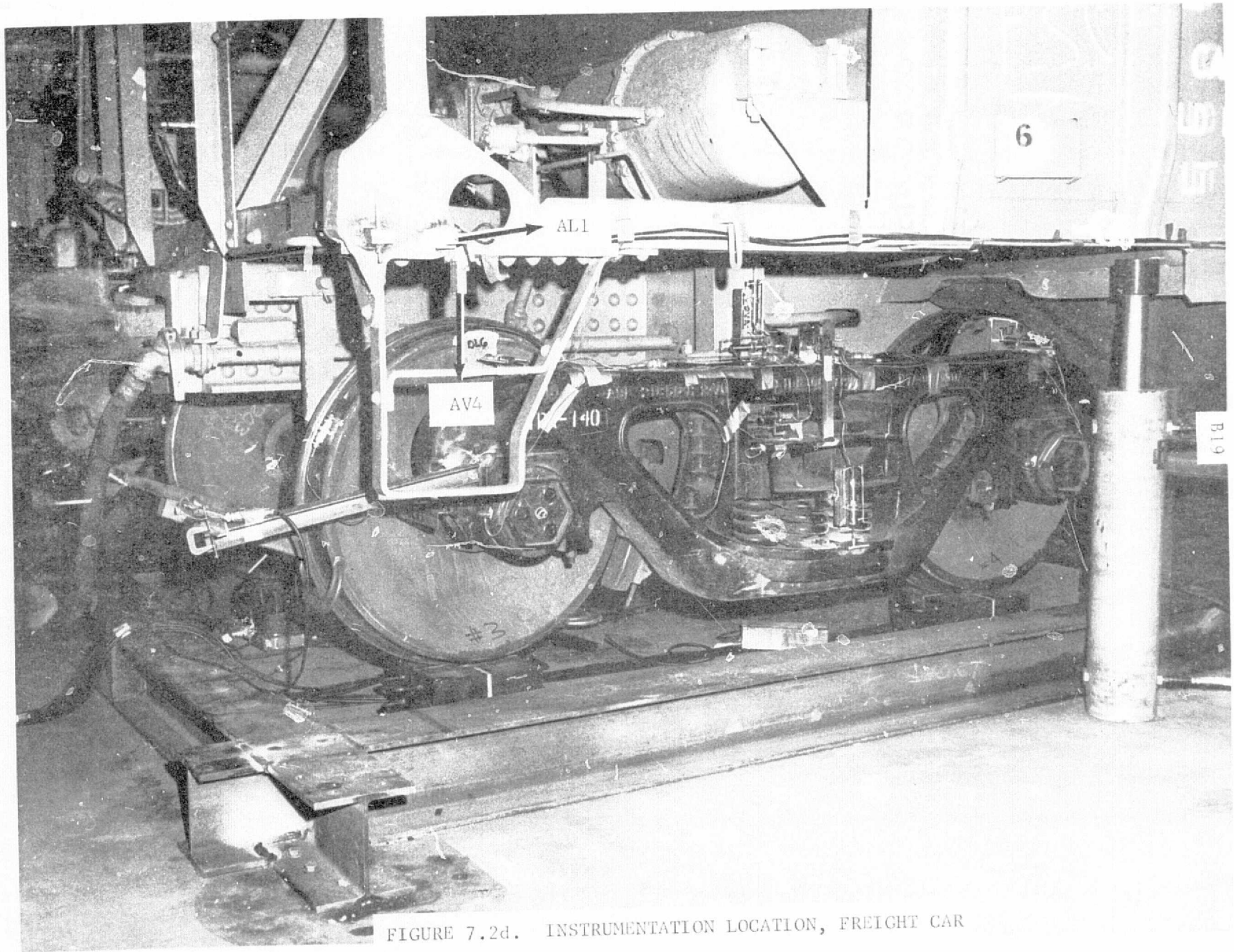

FIGURE 7.2d. INSTRUMENTATION LOCATION, FREIGHT CAR

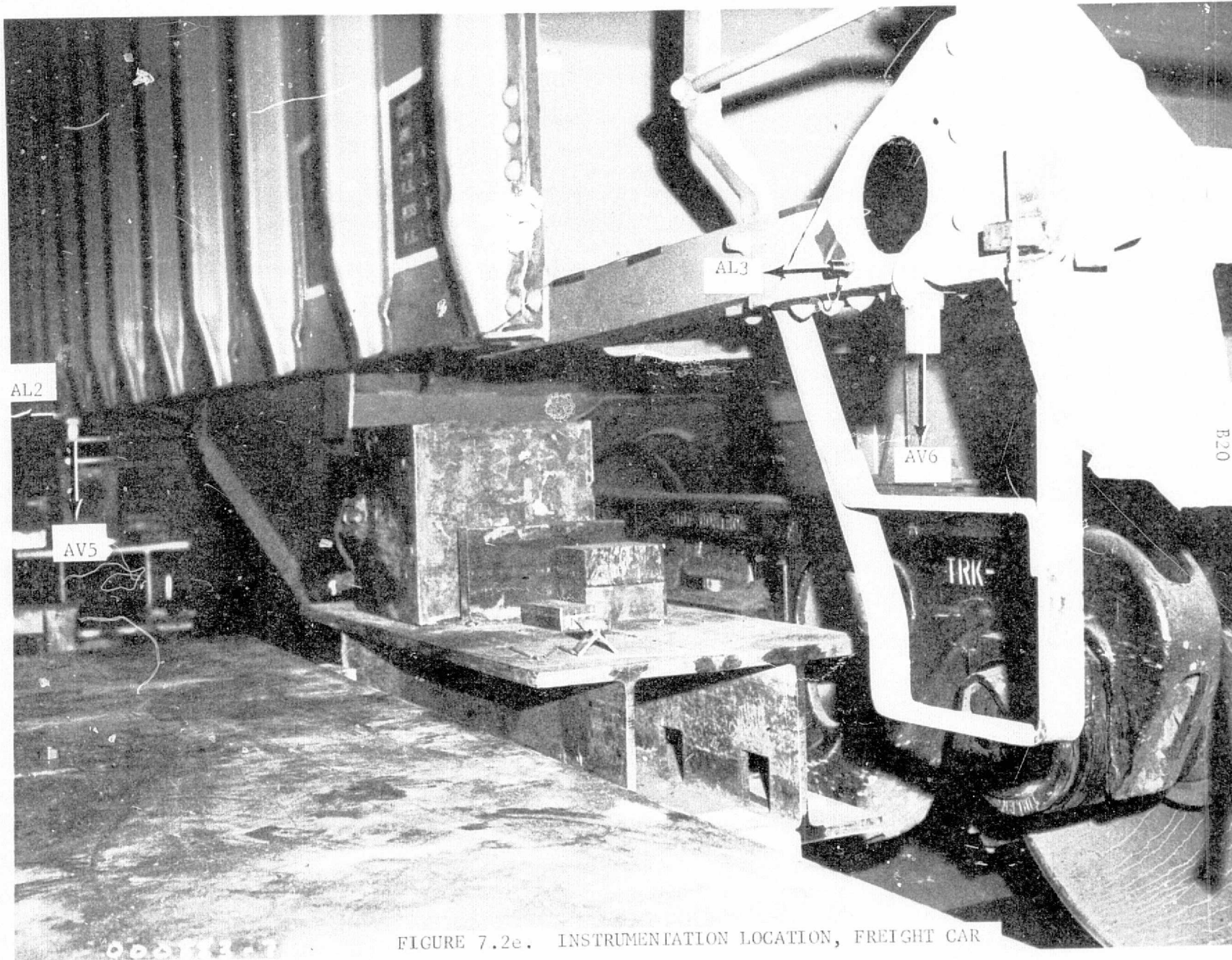

FIGURE 7.2e. INSTRUMENTATION LOCATION, FREIGHT CAR

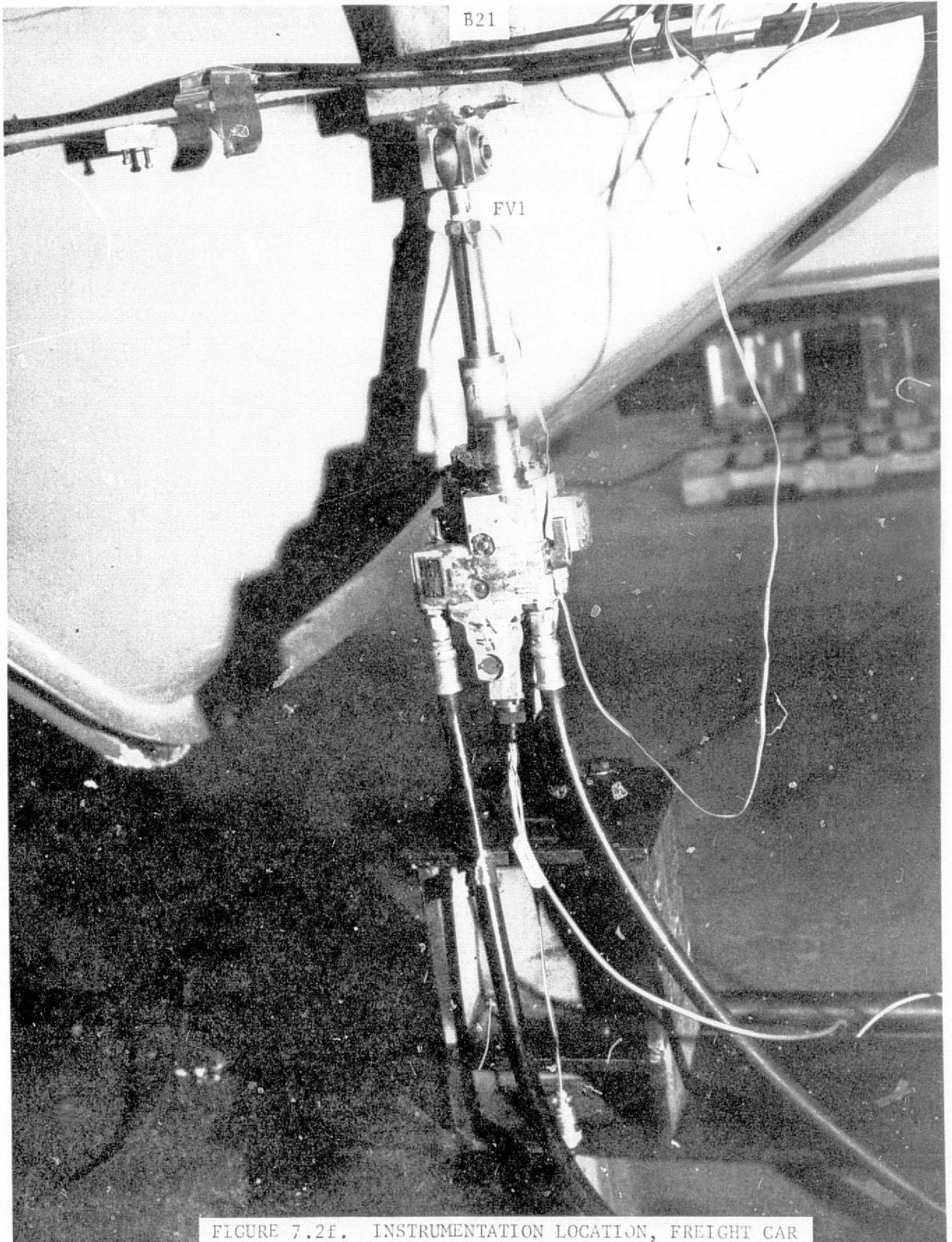
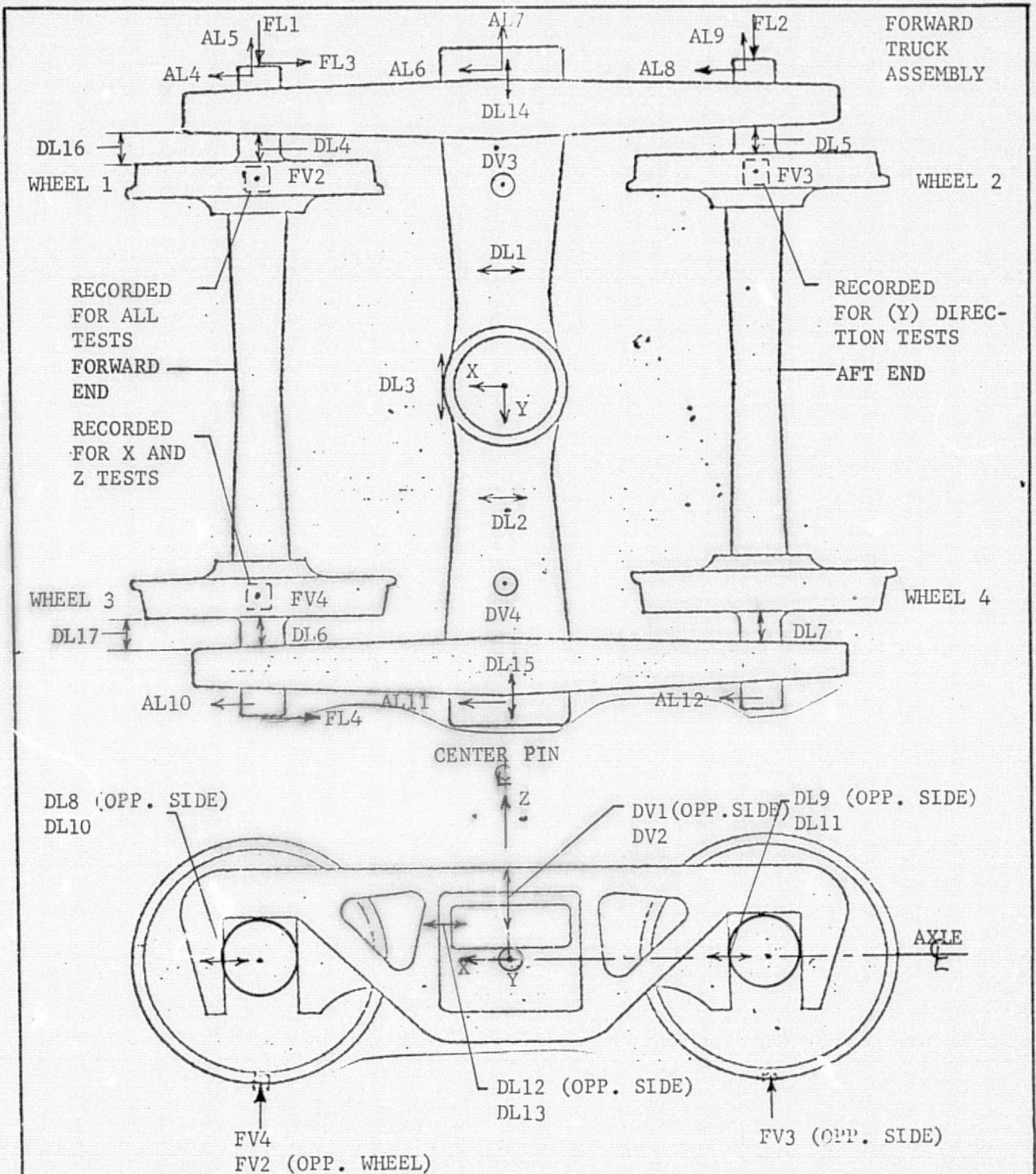

FIGURE 7.2f. INSTRUMENTATION LOCATION, FREIGHT CAR

ORIGINAL PAGE IS
OF POOR QUALITY



NOTES: DL1,2&3 ARE RELATIVE DISPL. OF BOLSTER WRT CAR, ALSO DV3 & DV4
 DL4 THROUGH DL11 ARE RELATIVE DISPL. OF SIDE FRAMES WRT AXLE
 DV1, DV2, DL12 & DL13 ARE RELATIVE DISPL. OF BOLSTER WRT SIDE FRAMES,
 ALSO DL14 & DL15
 DL16 & DL17 ARE RELATIVE DISPL. OF SIDE FRAMES WRT WHEELS 1 & 3
 RESPECTIVELY.

R FIGURE 7.3 TRUCK INSTRUMENTATION LOCATIONS AND MEASUREMENT NUMBERS

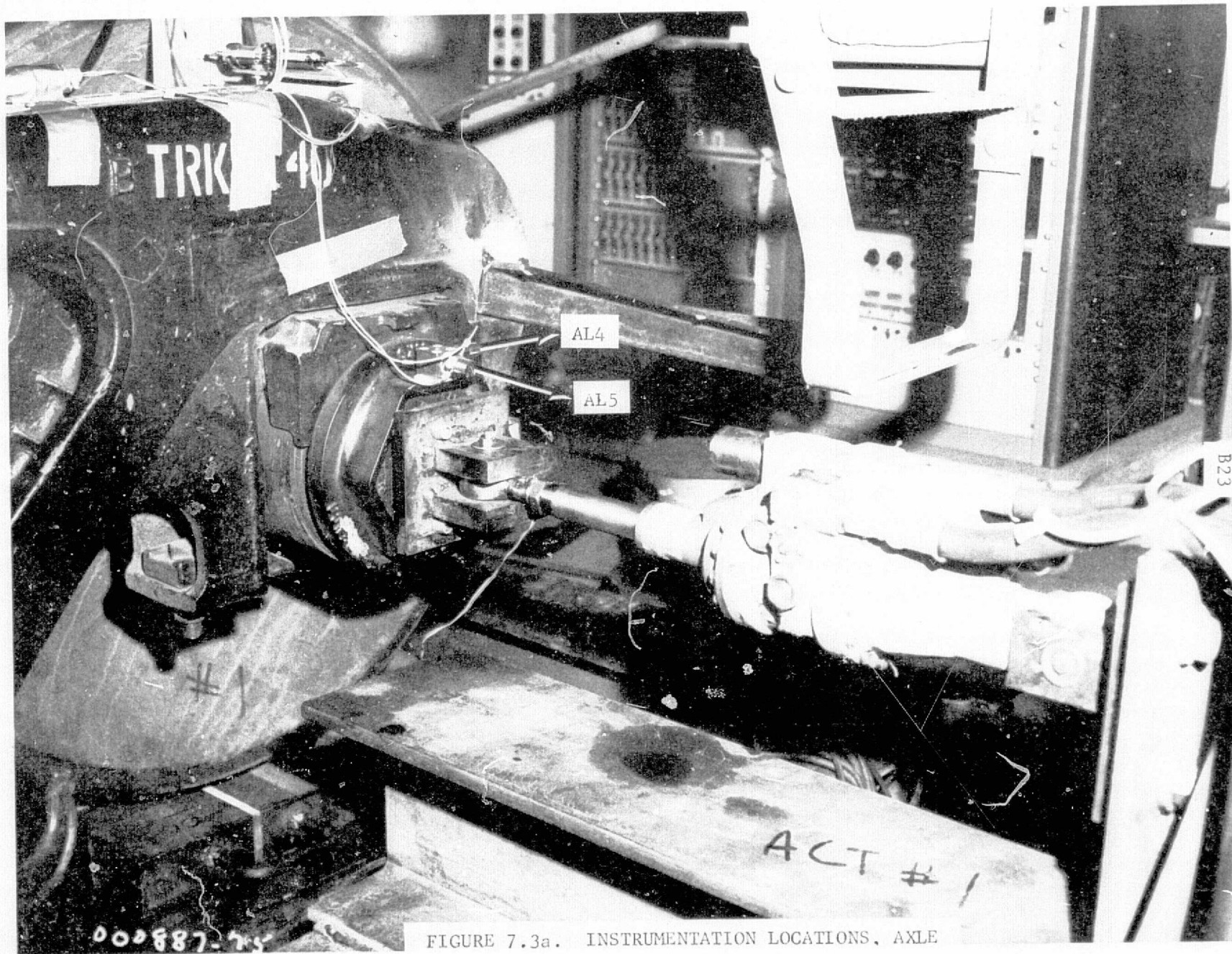

FIGURE 7.3a. INSTRUMENTATION LOCATIONS, AXLE

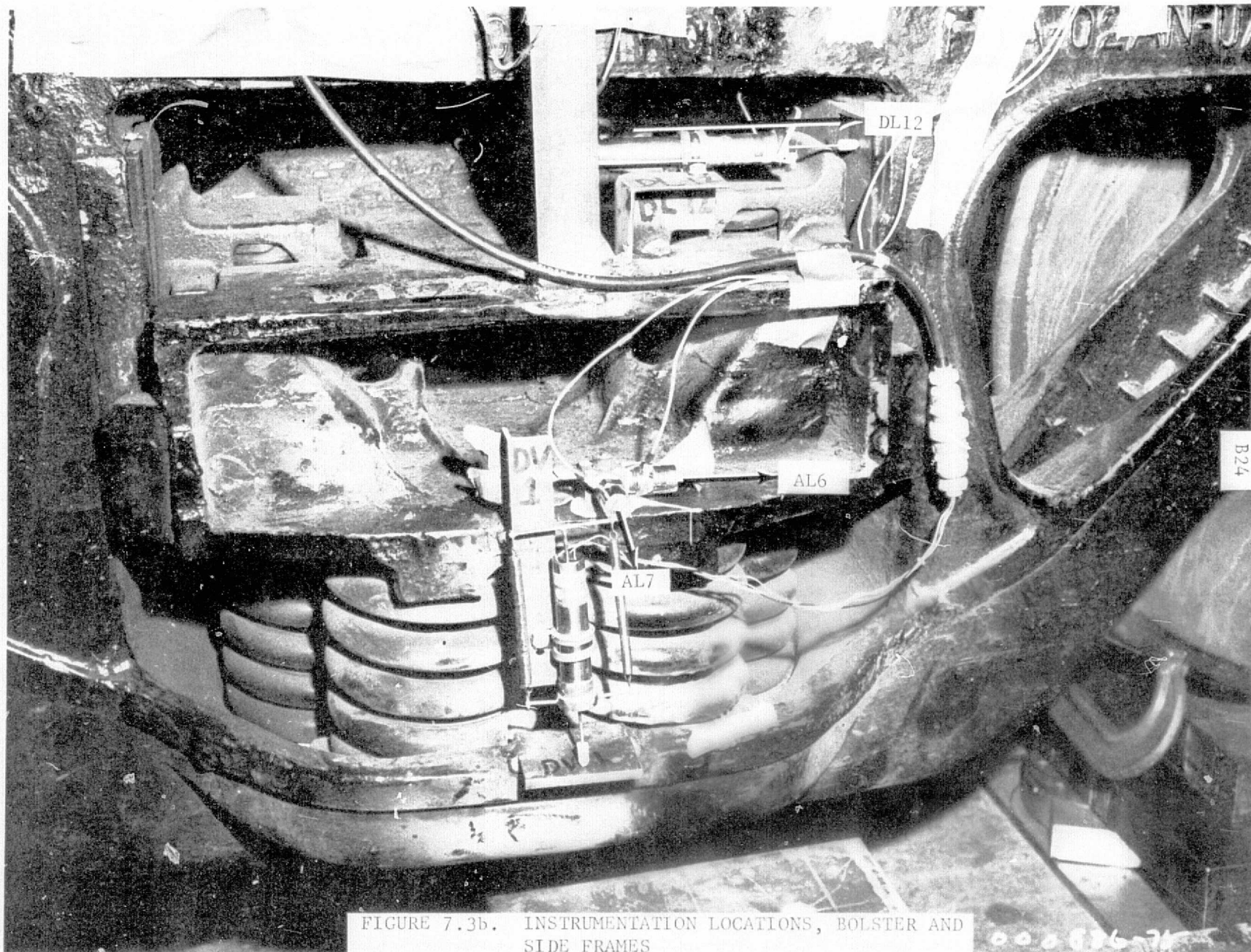

FIGURE 7.3b. INSTRUMENTATION LOCATIONS, BOLSTER AND SIDE FRAMES

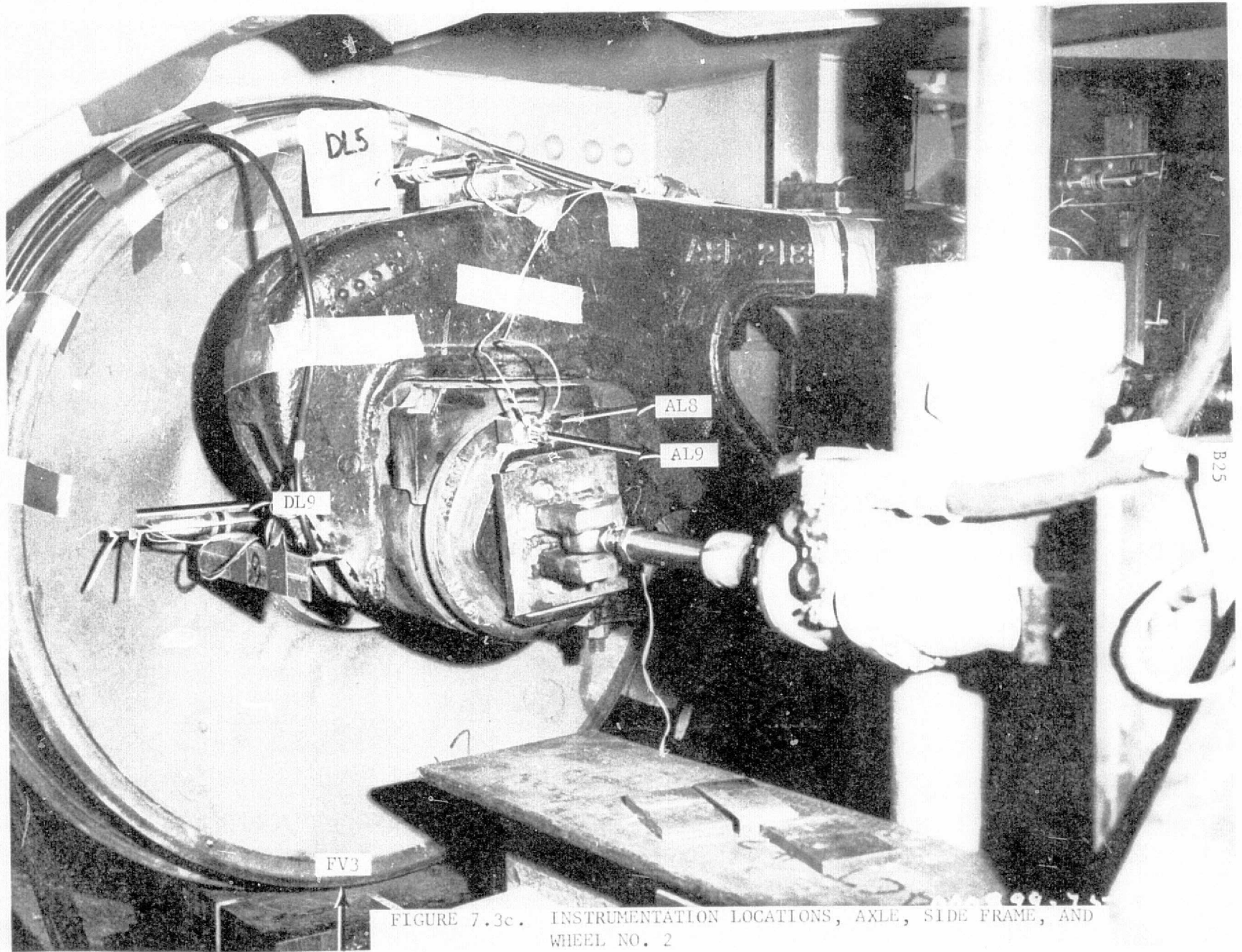
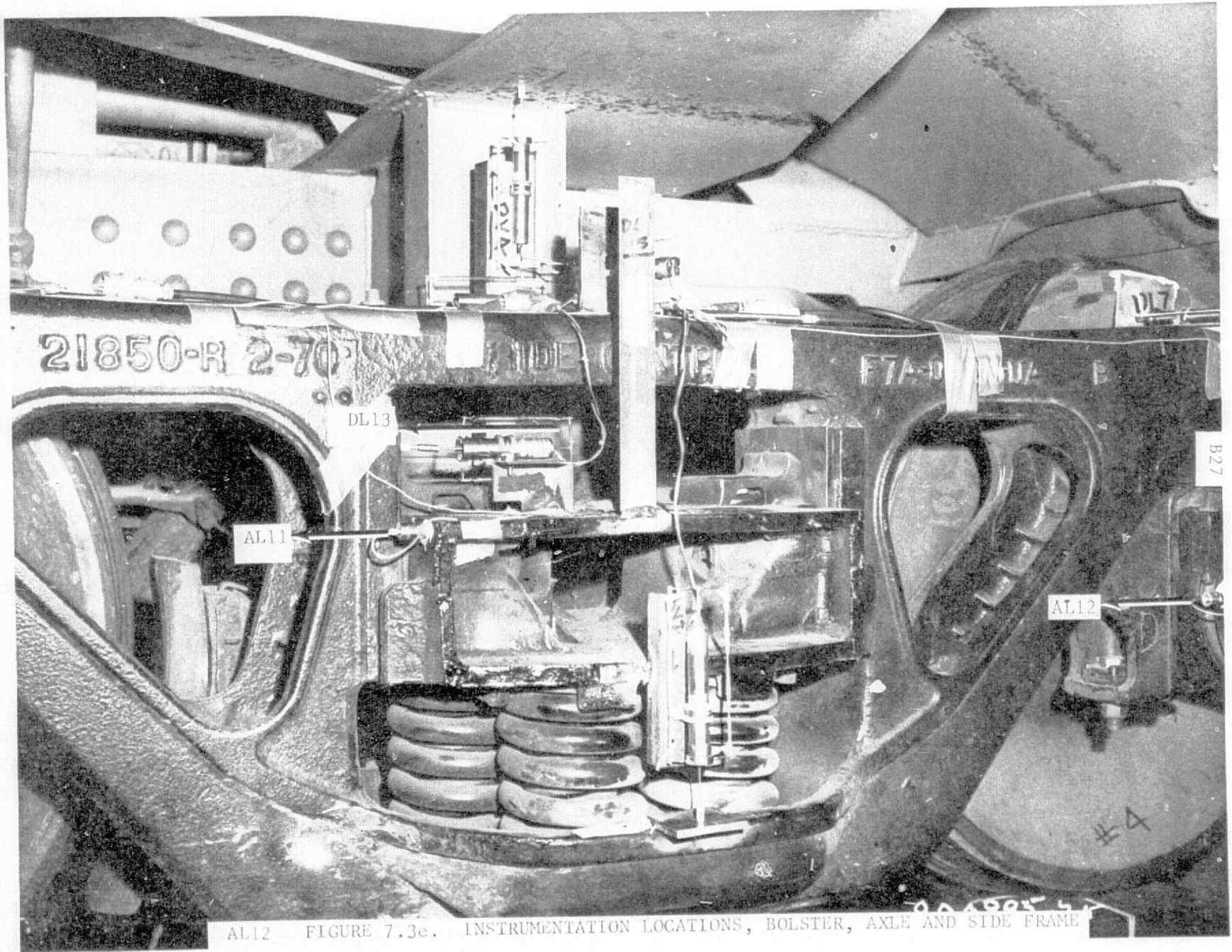

FIGURE 7.3c. INSTRUMENTATION LOCATIONS, AXLE, SIDE FRAME, AND WHEEL NO. 2

ORIGINAL PAGE IS
OF POOR QUALITY



AL12 FIGURE 7.3e. INSTRUMENTATION LOCATIONS, BOLSTER, AXLE AND SIDE FRAME

ORIGINAL PAGE IS
OF POOR QUALITY

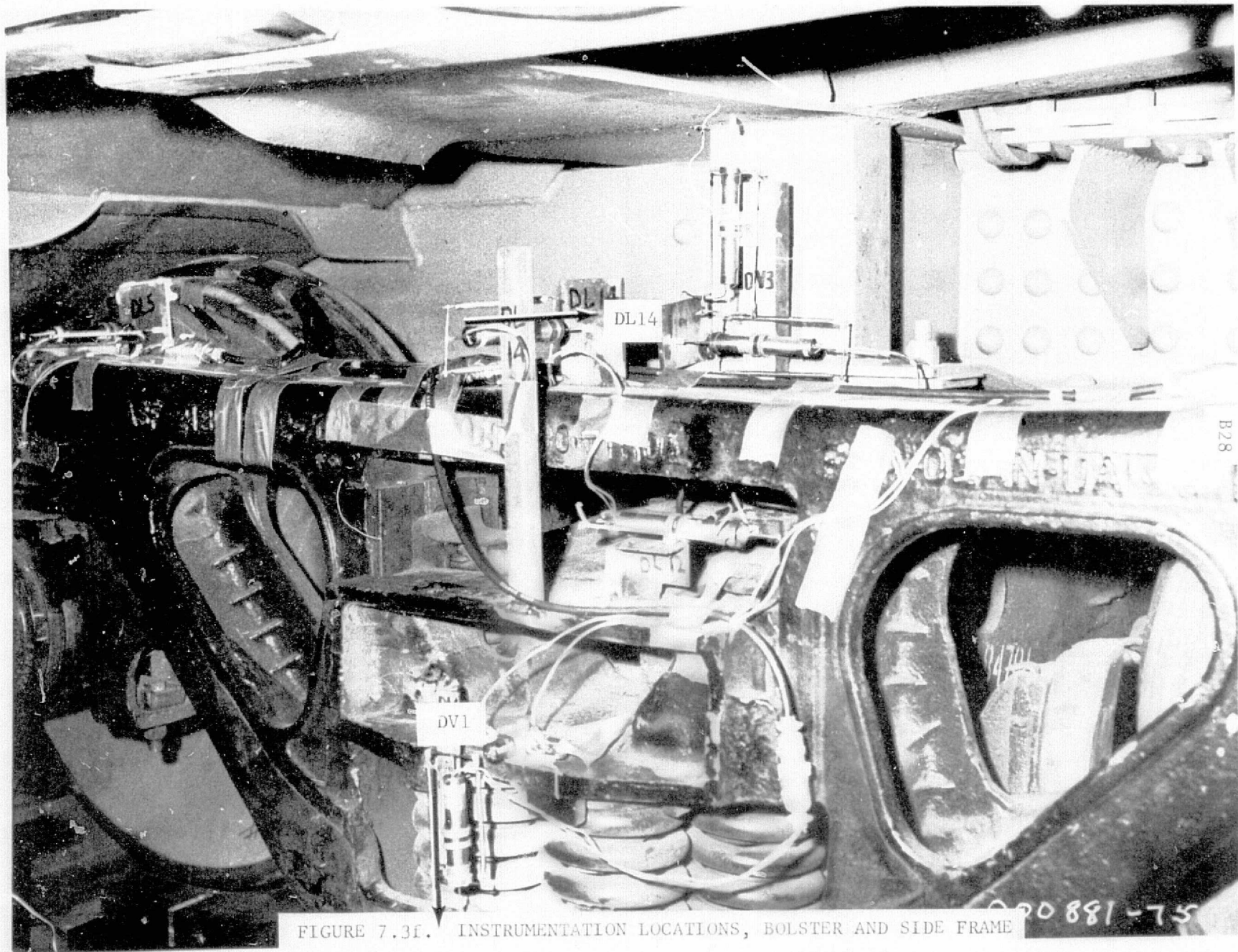
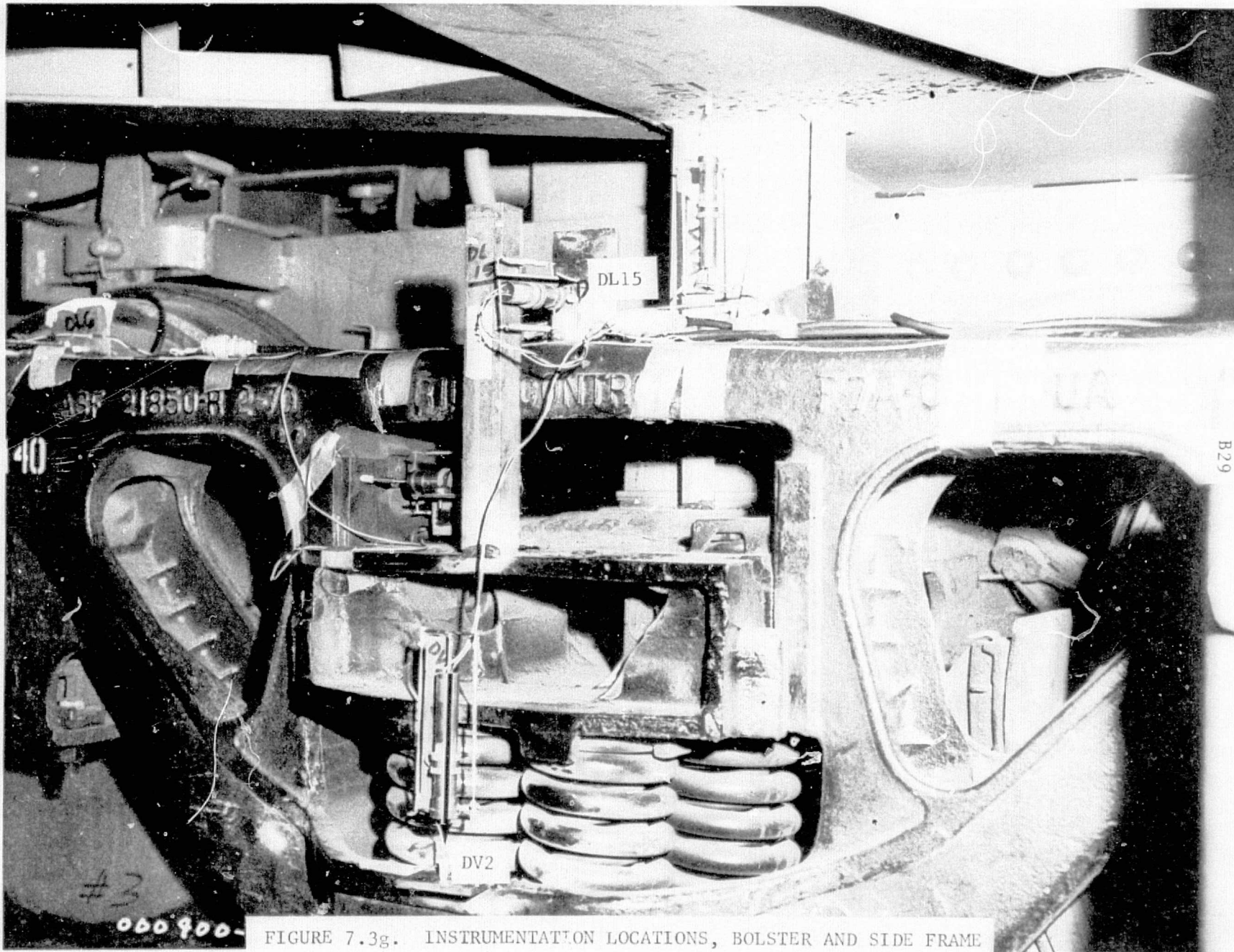

FIGURE 7.3f. INSTRUMENTATION LOCATIONS, BOLSTER AND SIDE FRAME

ORIGINAL PAGE IS
OF POOR QUALITY



B29

FIGURE 7.3g. INSTRUMENTATION LOCATIONS, BOLSTER AND SIDE FRAME

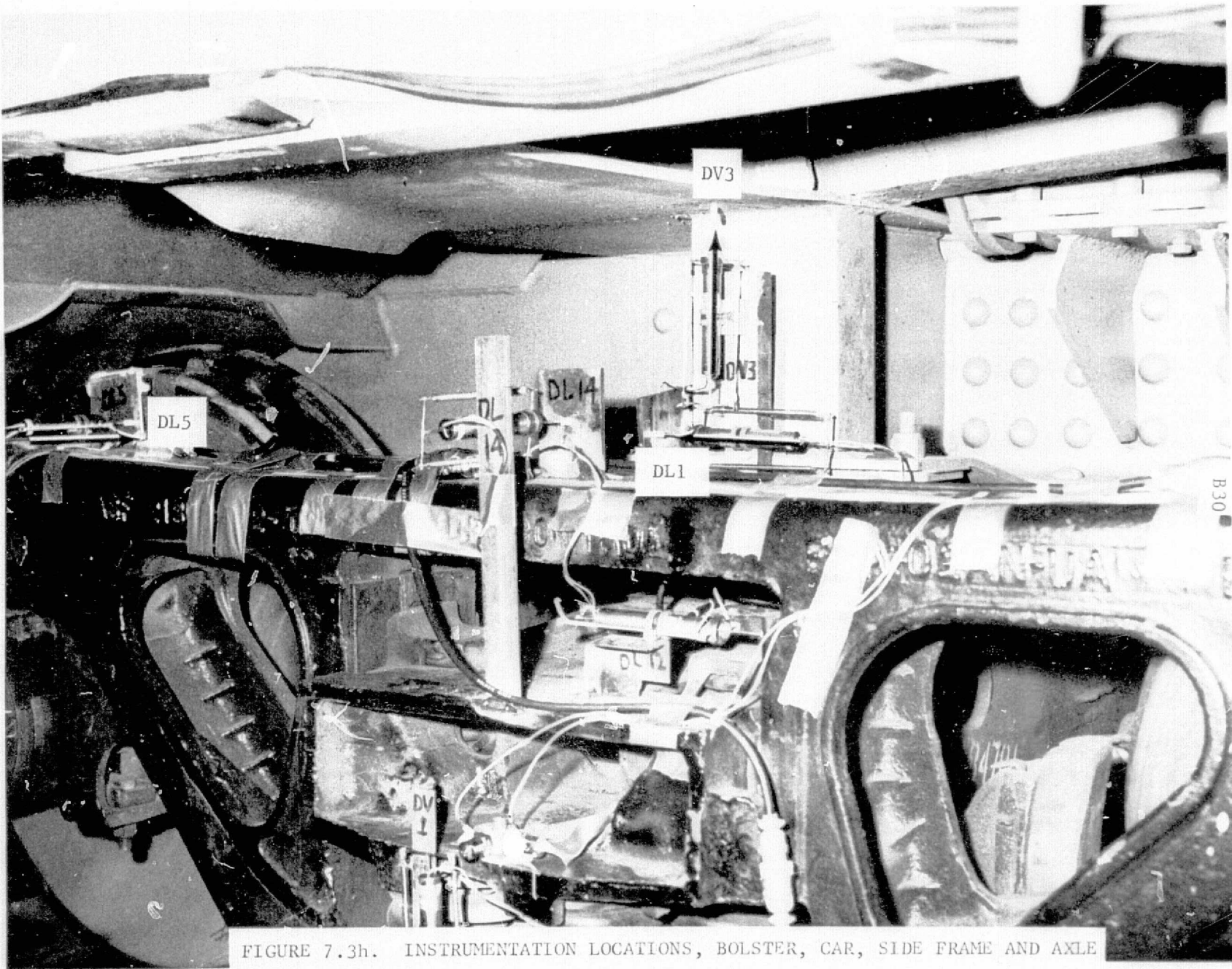

FIGURE 7.3h. INSTRUMENTATION LOCATIONS, BOLSTER, CAR, SIDE FRAME AND AXLE

ORIGINAL PAGE IS
OF POOR QUALITY

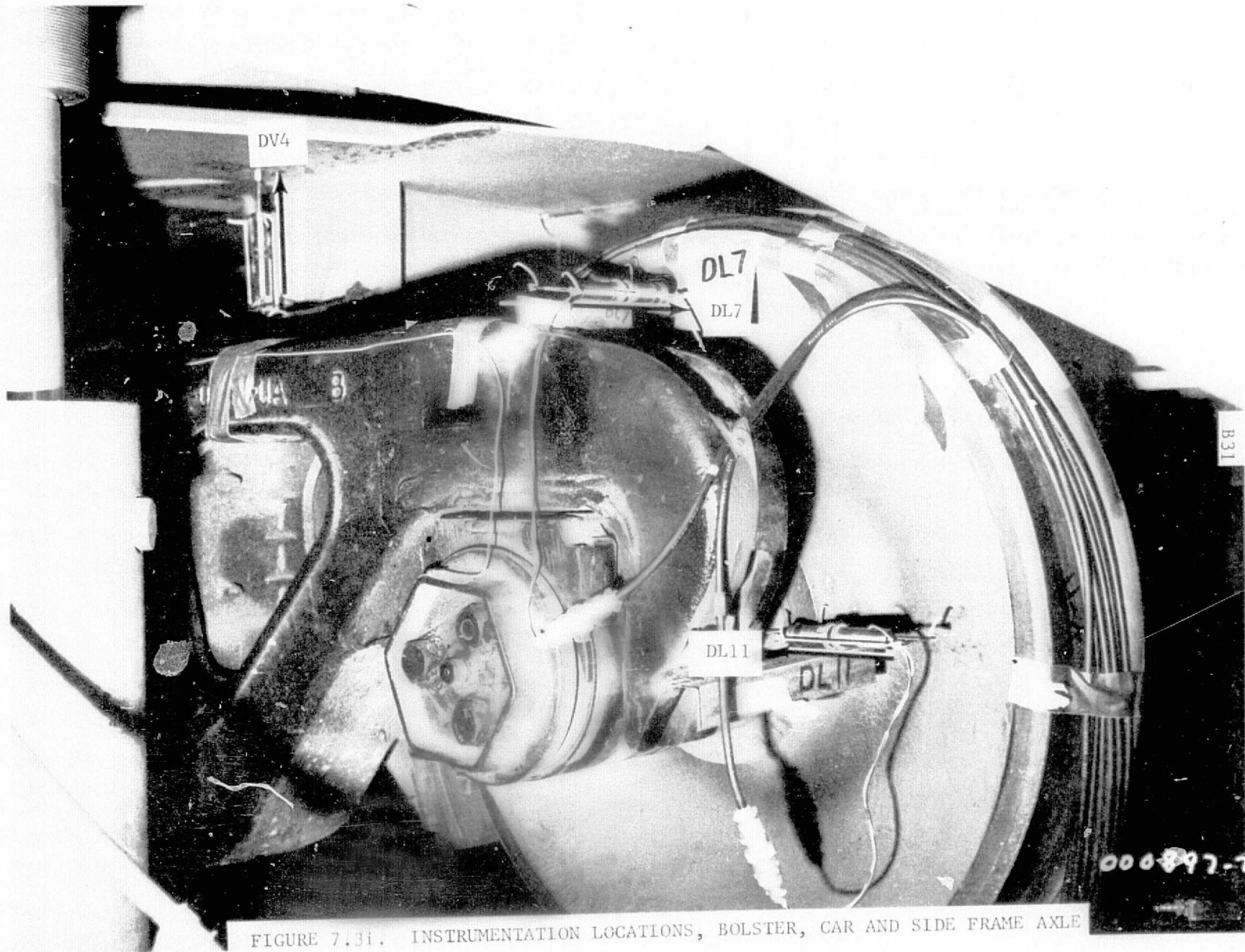

FIGURE 7.31. INSTRUMENTATION LOCATIONS, BOLSTER, CAR AND SIDE FRAME AXLE

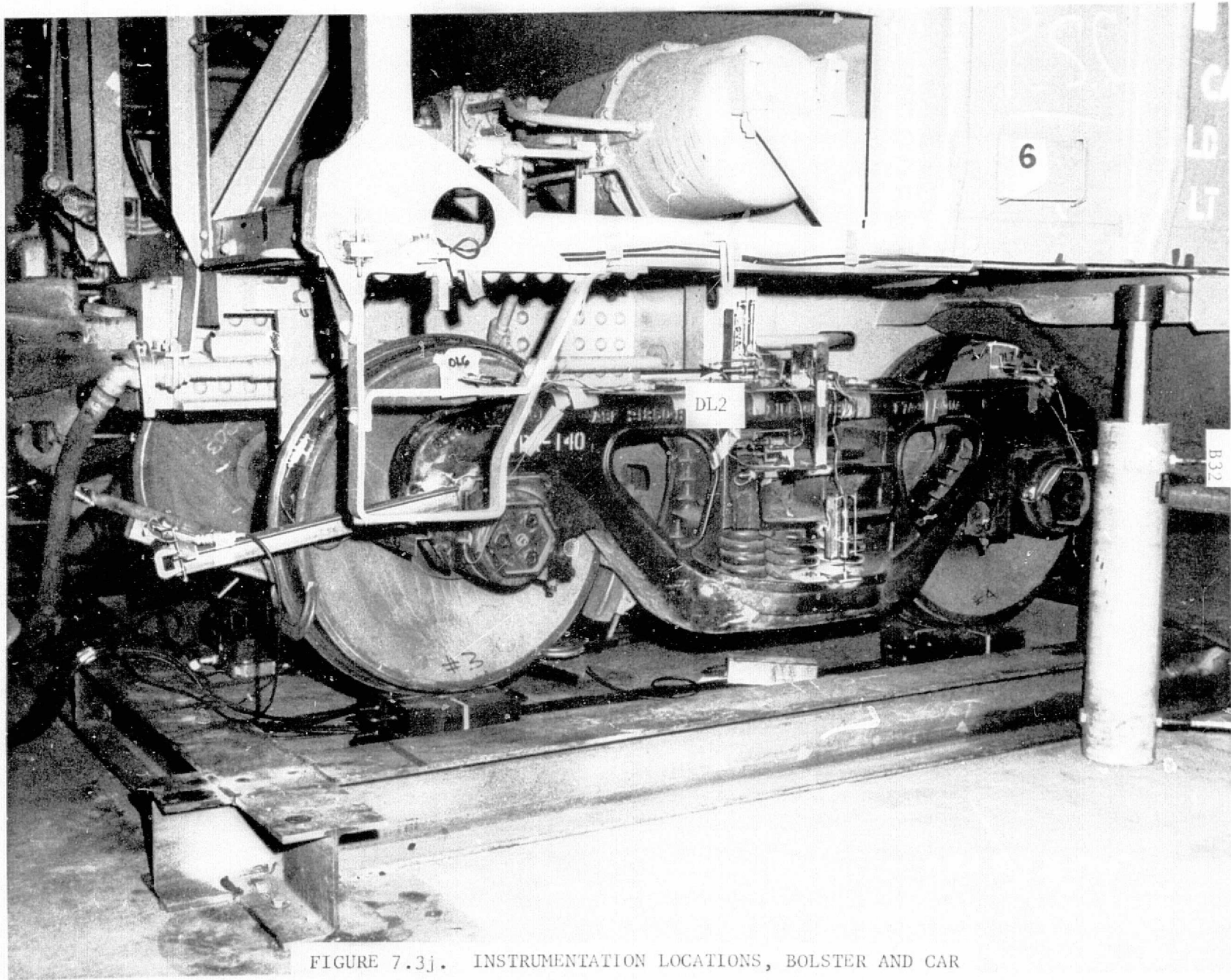

FIGURE 7.3j. INSTRUMENTATION LOCATIONS, BOLSTER AND CAR

C-2

ORIGINAL PAGE IS
OF BETTER QUALITY

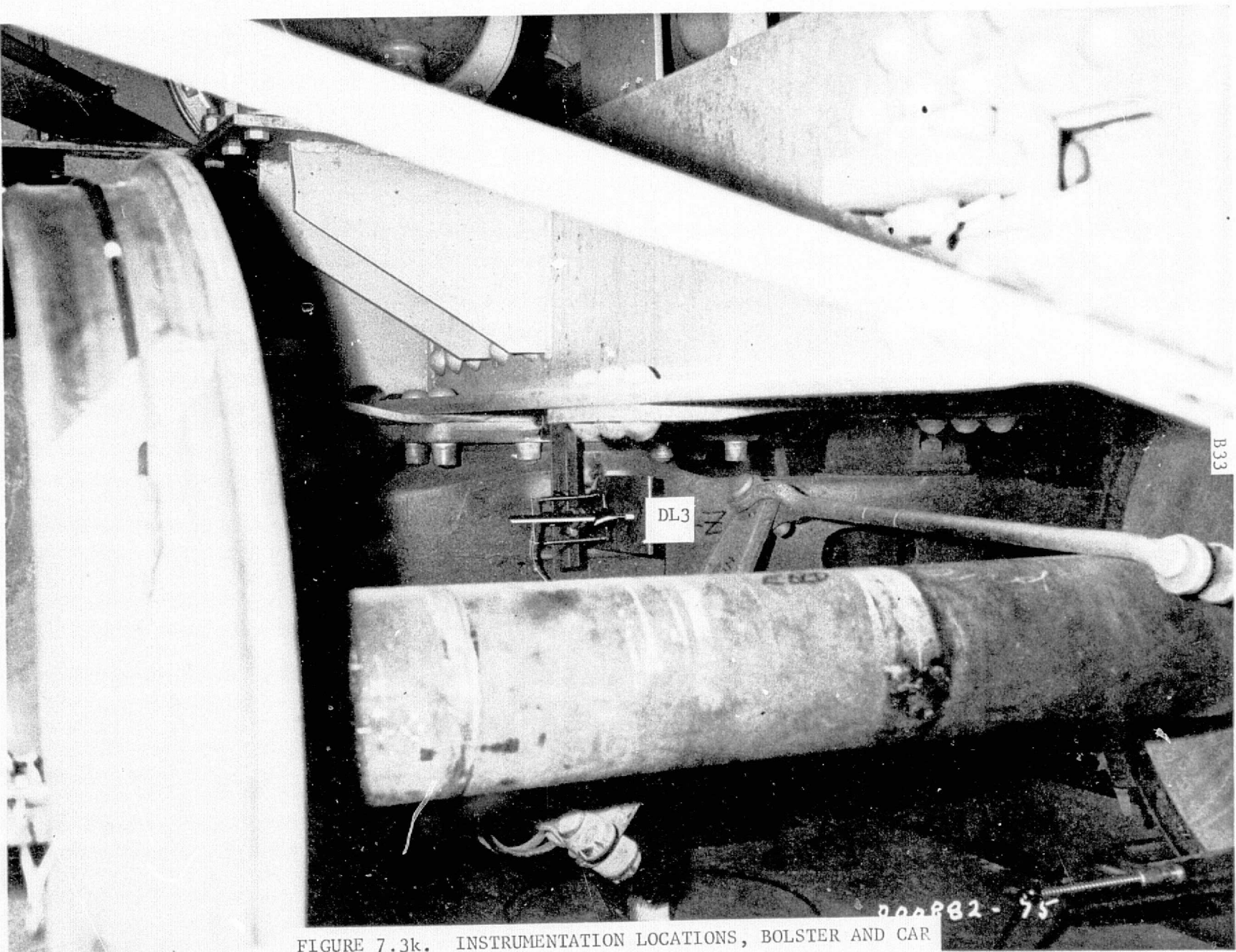

FIGURE 7.3k. INSTRUMENTATION LOCATIONS, BOLSTER AND CAR

ORIGINAL PAGE IS
OF POOR QUALITY

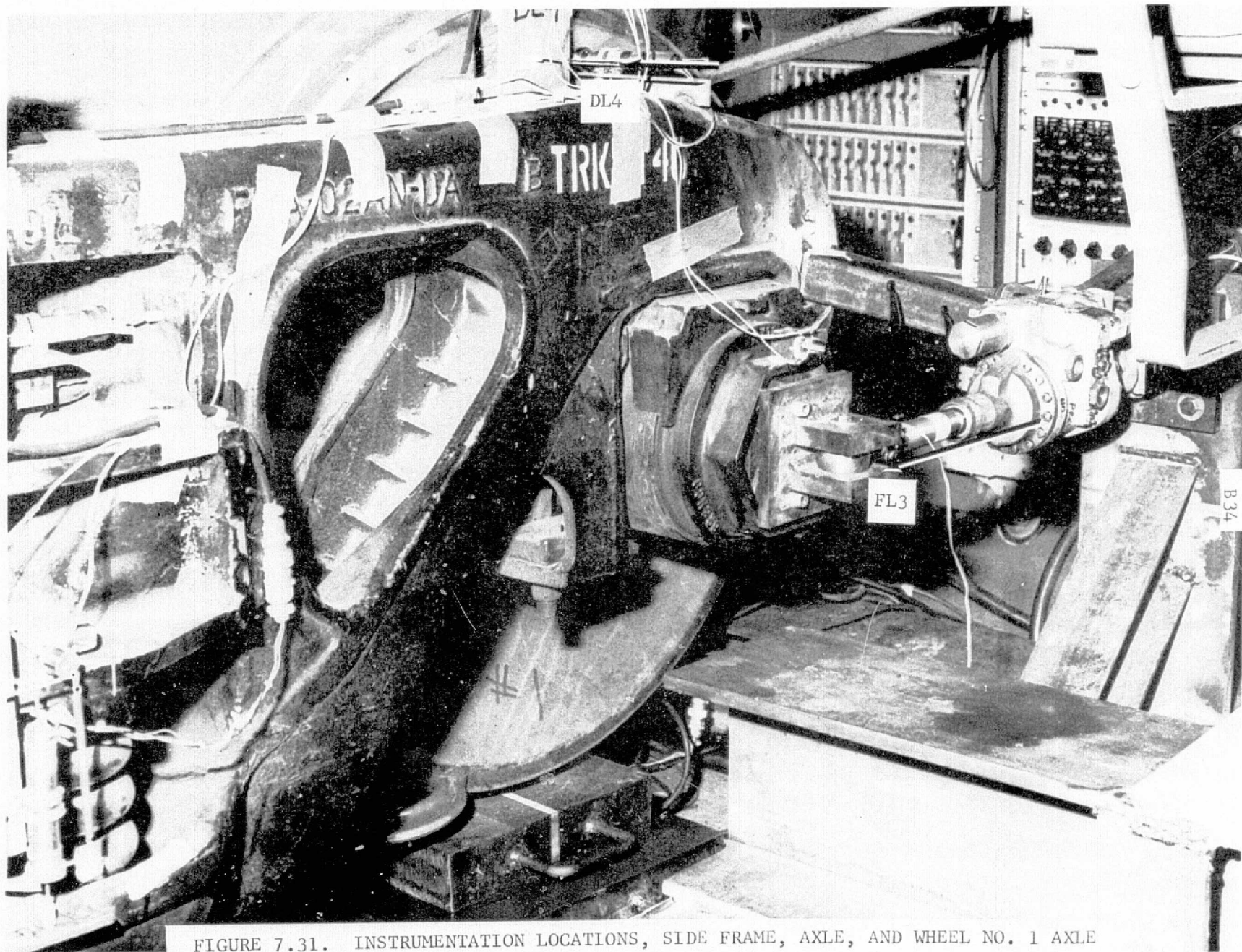

FIGURE 7.31. INSTRUMENTATION LOCATIONS, SIDE FRAME, AXLE, AND WHEEL NO. 1 AXLE

ORIGINAL PAGE IS
OF POOR QUALITY

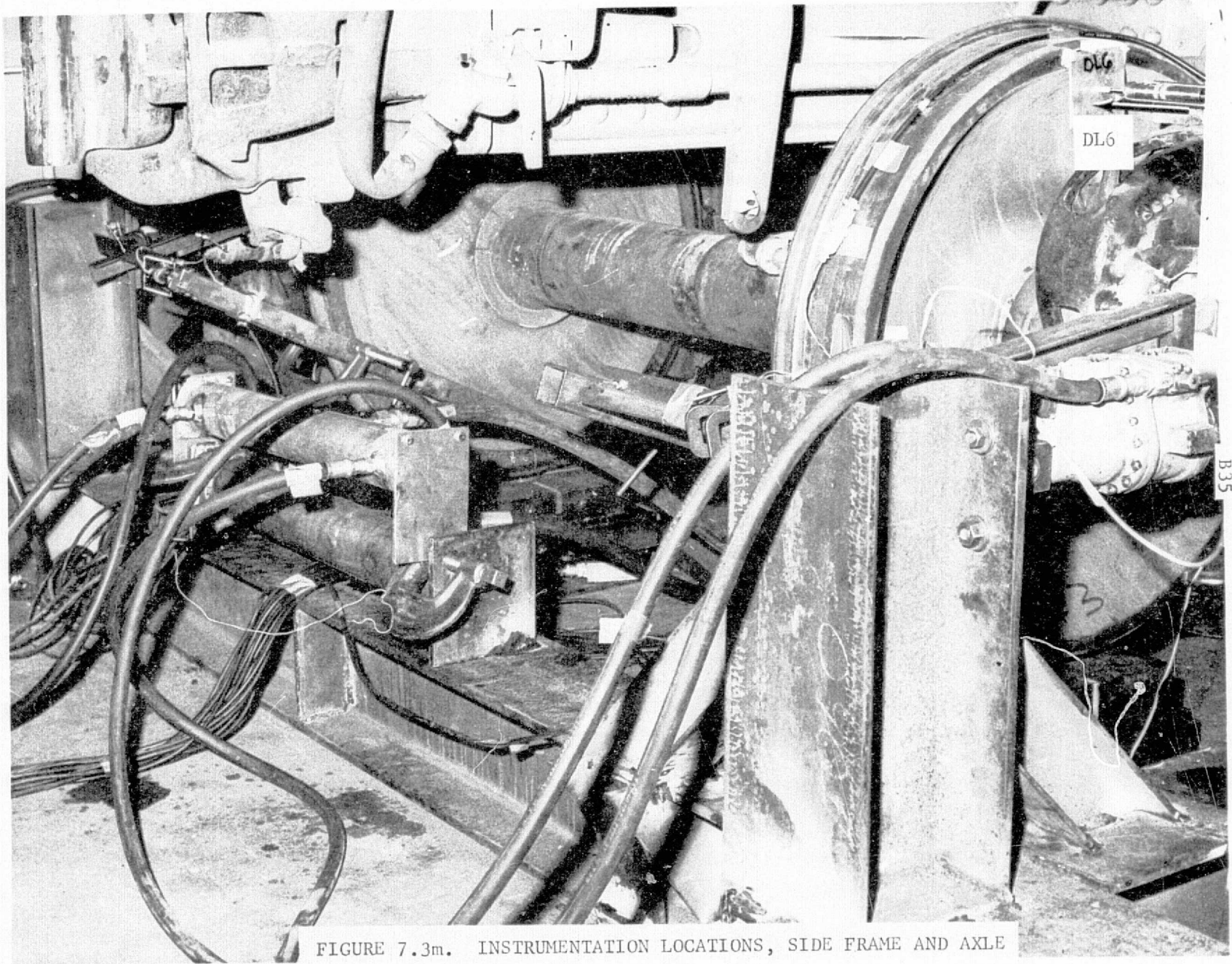

FIGURE 7.3m. INSTRUMENTATION LOCATIONS, SIDE FRAME AND AXLE

B35

ORIGINAL PAGE IS
OF POOR QUALITY

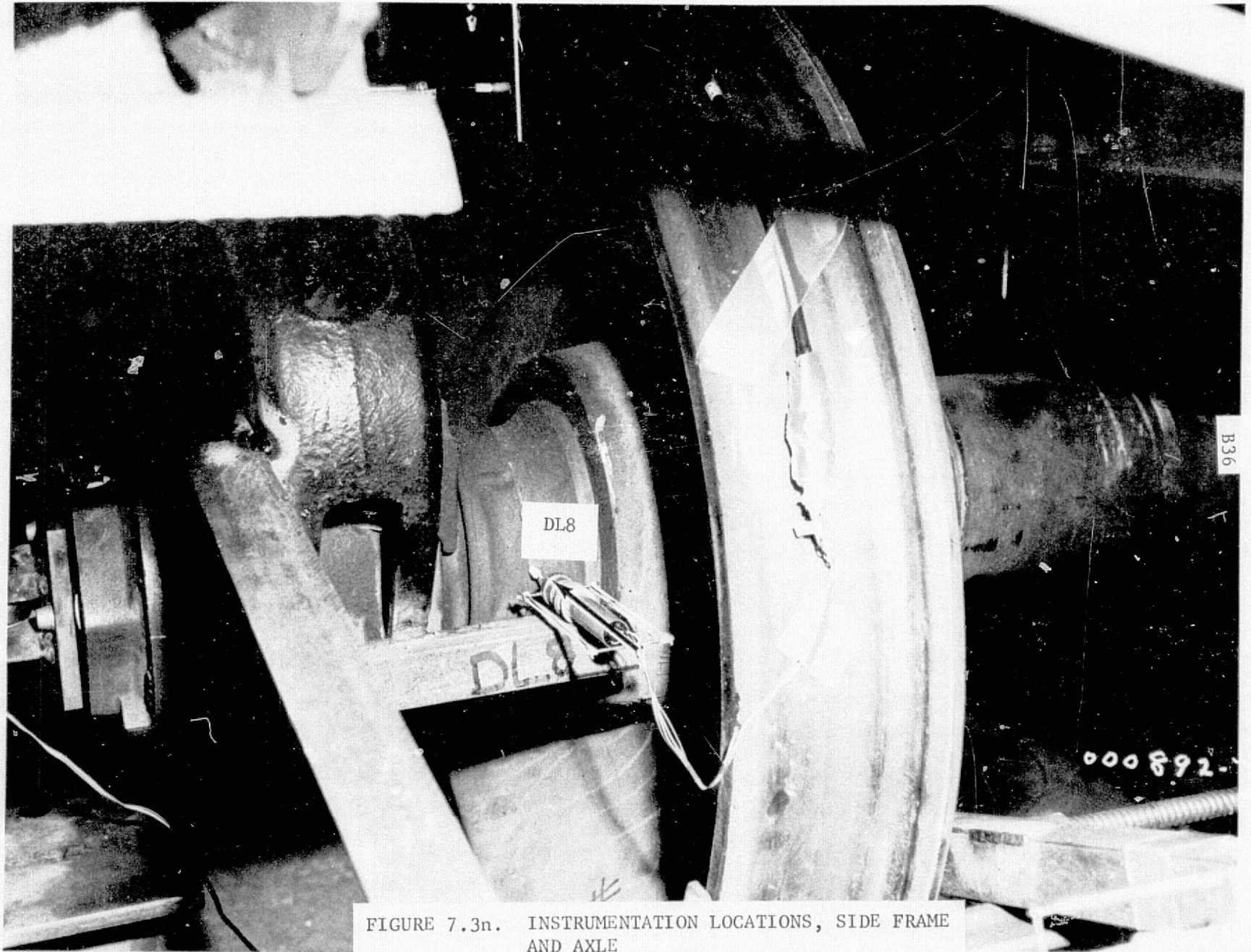

FIGURE 7.3n. INSTRUMENTATION LOCATIONS, SIDE FRAME AND AXLE

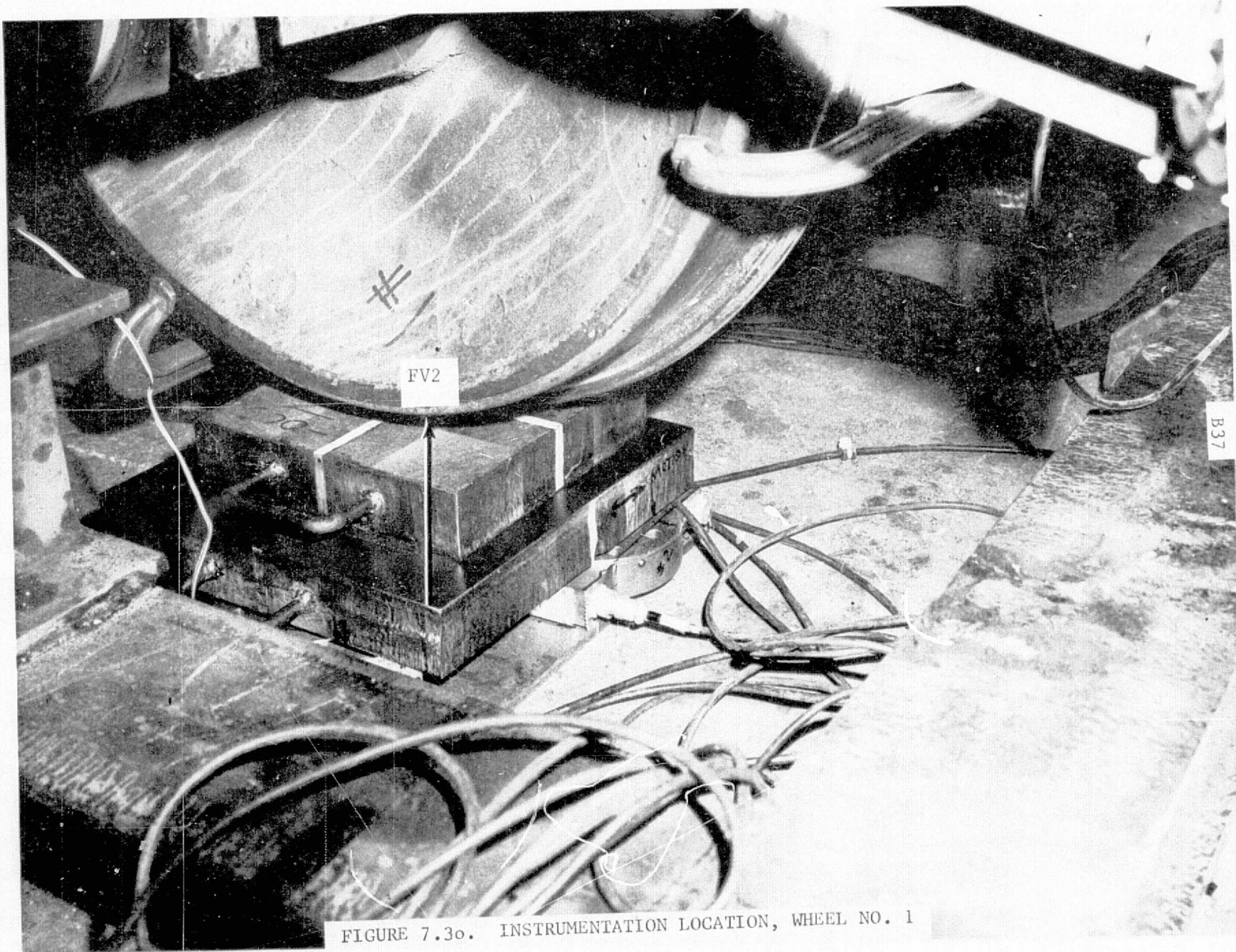

FIGURE 7.30. INSTRUMENTATION LOCATION, WHEEL NO. 1

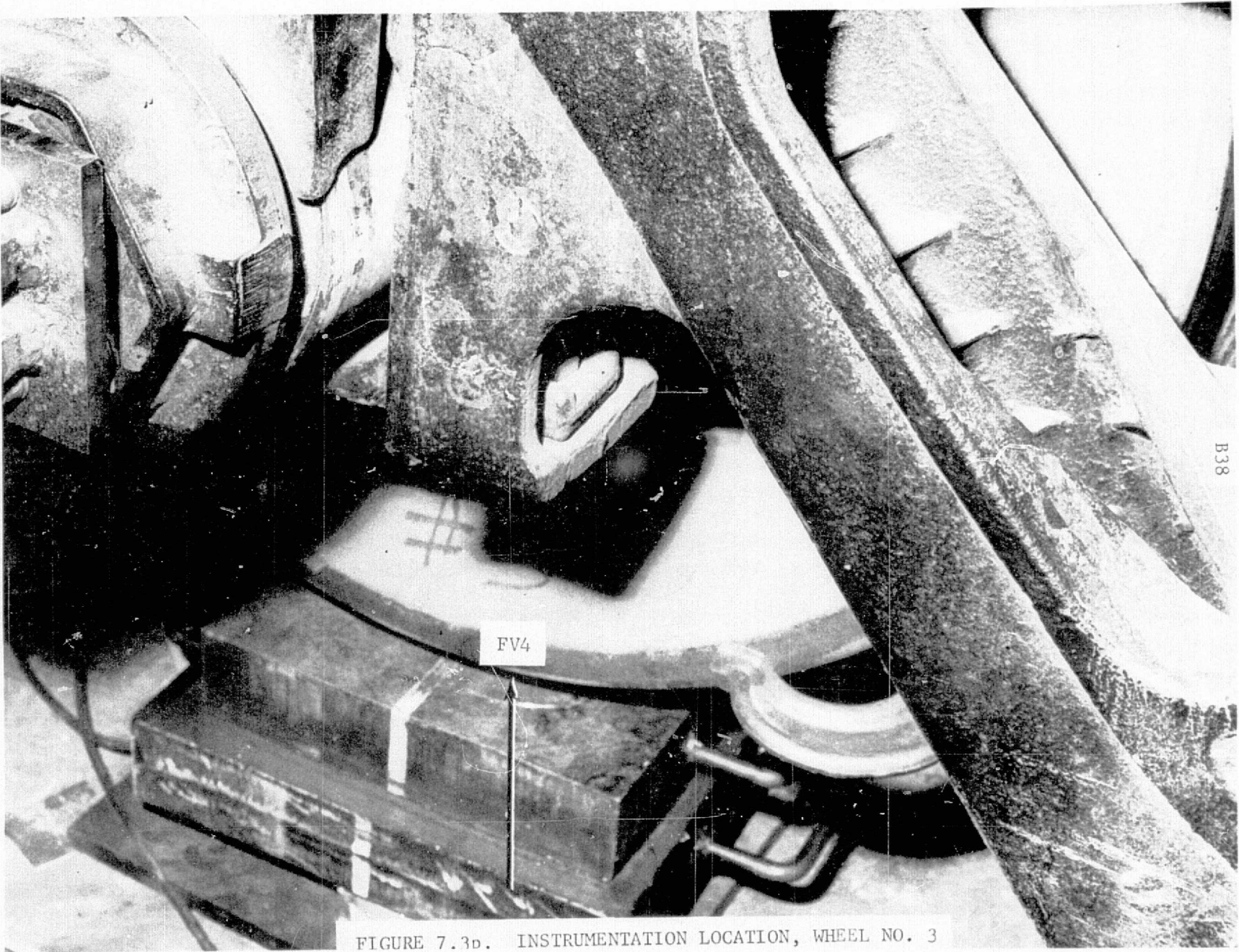

FIGURE 7.3D. INSTRUMENTATION LOCATION, WHEEL NO. 3

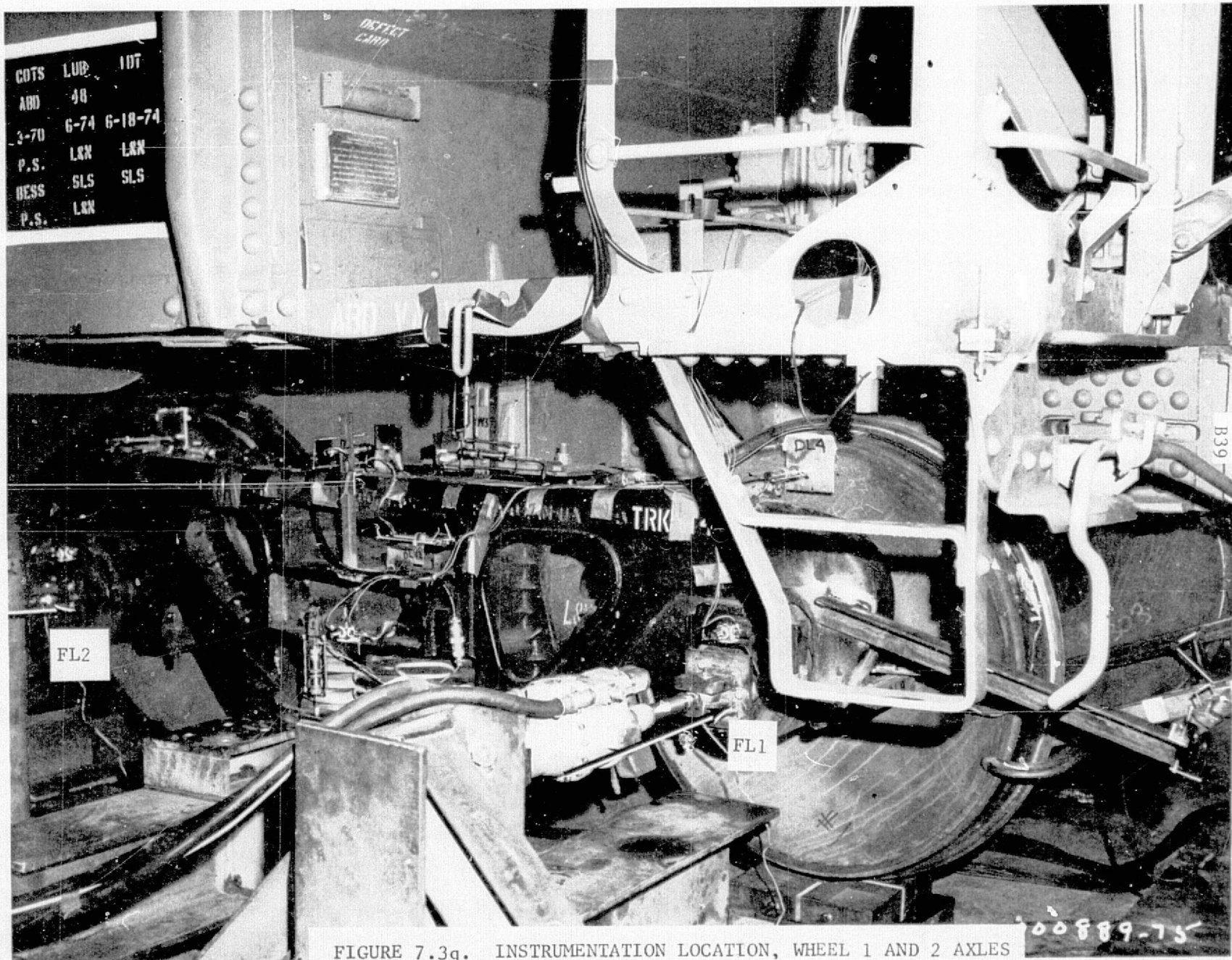

FIGURE 7.3a. INSTRUMENTATION LOCATION, WHEEL 1 AND 2 AXLES

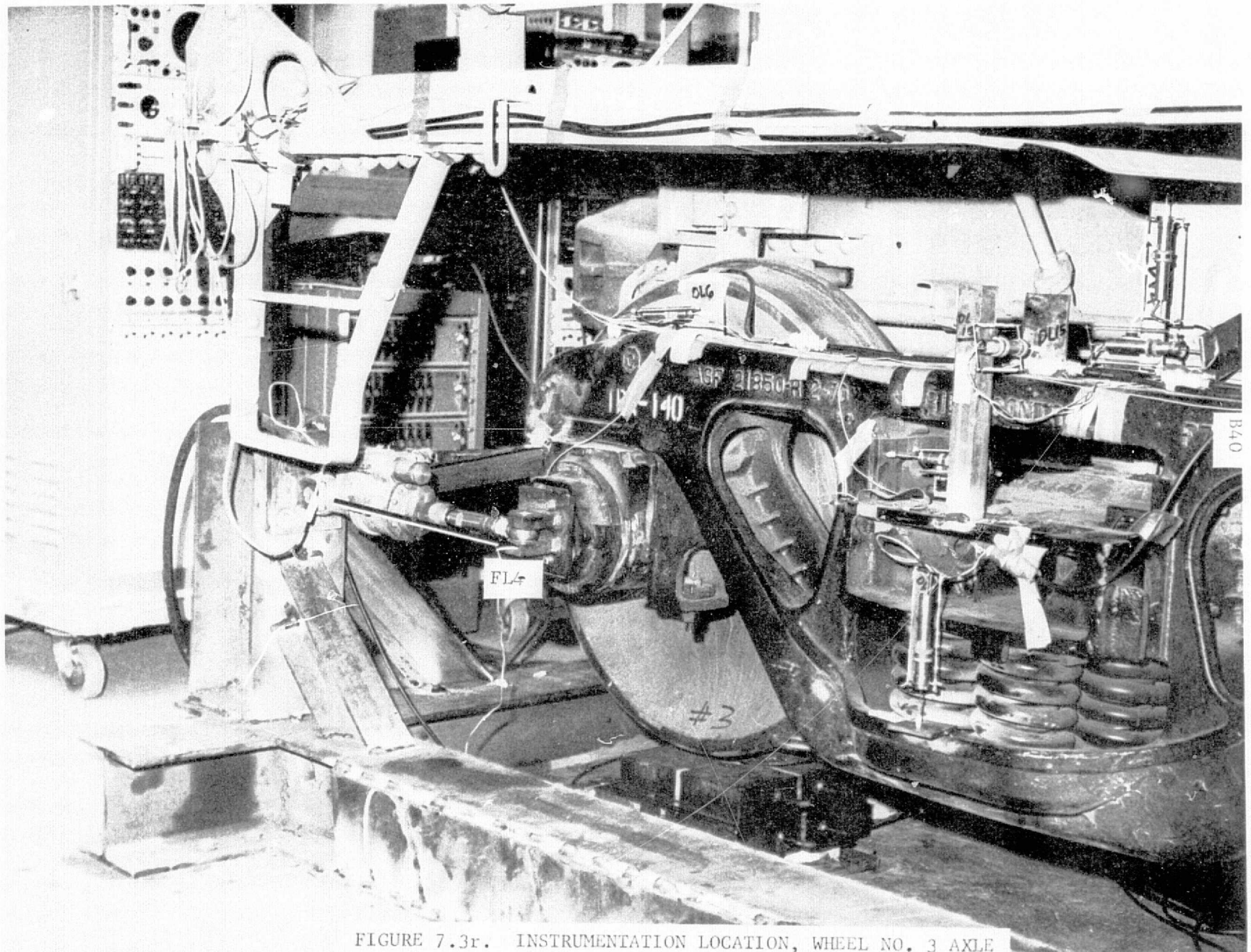
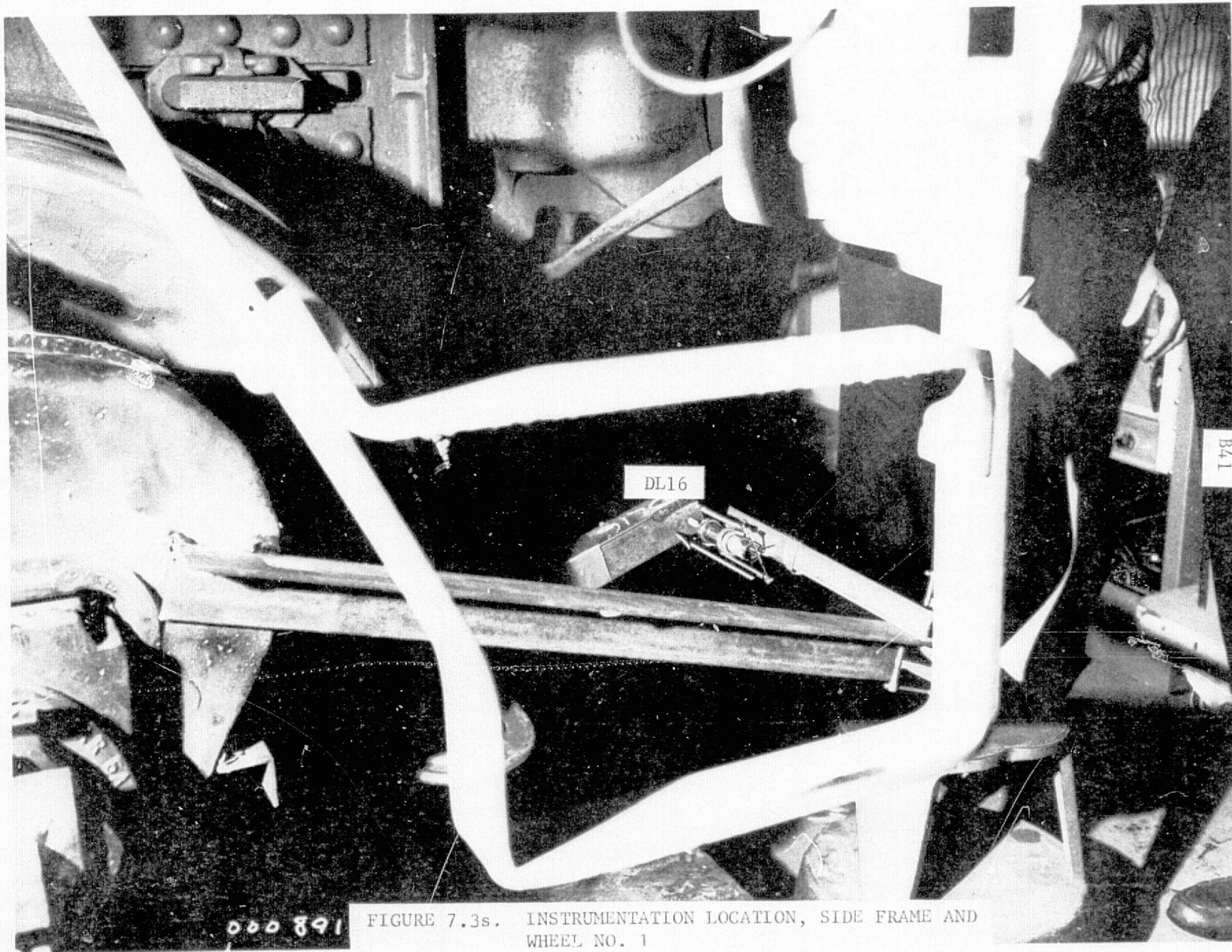

FIGURE 7.3r. INSTRUMENTATION LOCATION, WHEEL NO. 3 AXLE



000 891

FIGURE 7.3s. INSTRUMENTATION LOCATION, SIDE FRAME AND WHEEL NO. 1

ORIGINAL PAGE IS
OF POOR QUALITY

B42

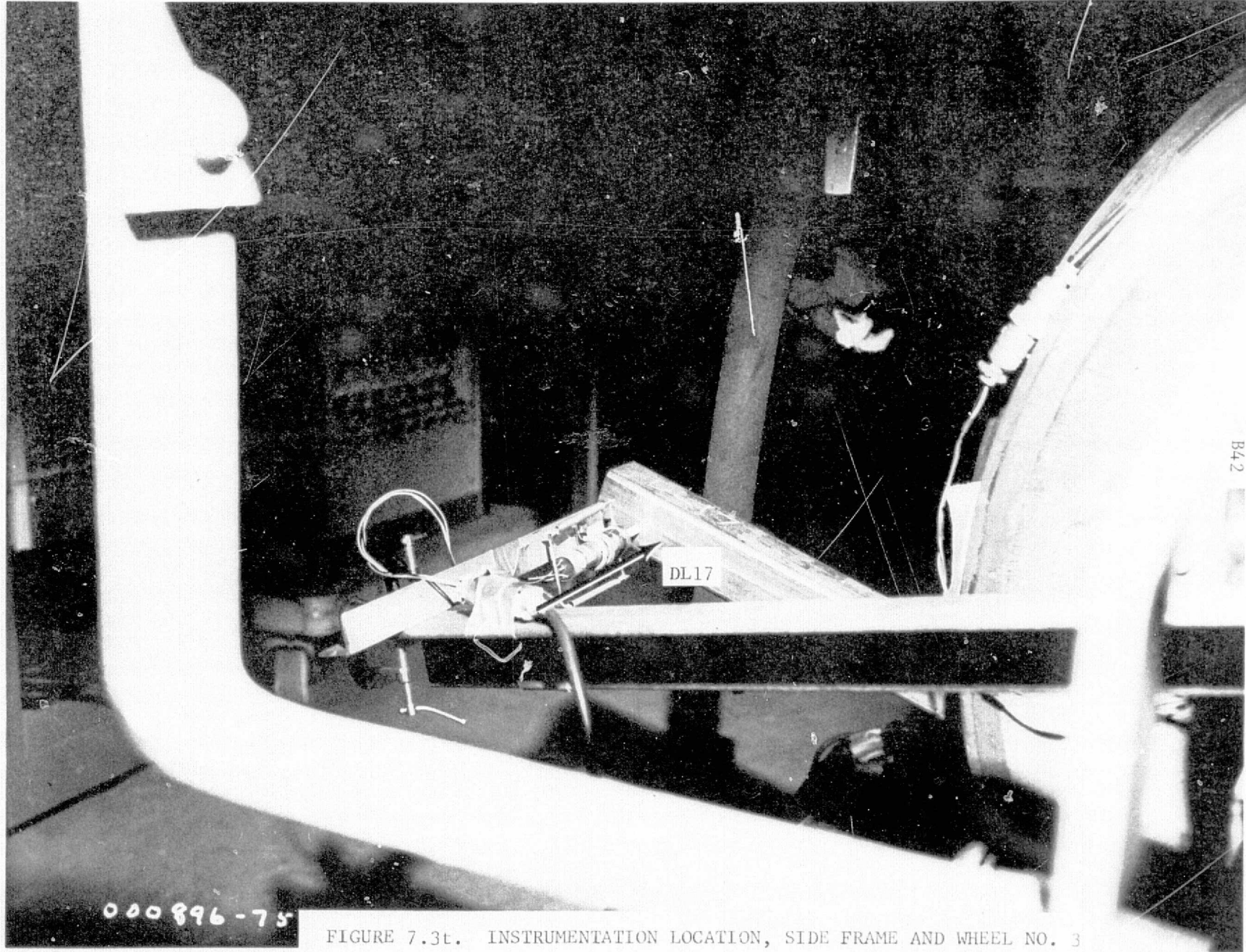

000896-75

FIGURE 7.3t. INSTRUMENTATION LOCATION, SIDE FRAME AND WHEEL NO. 3

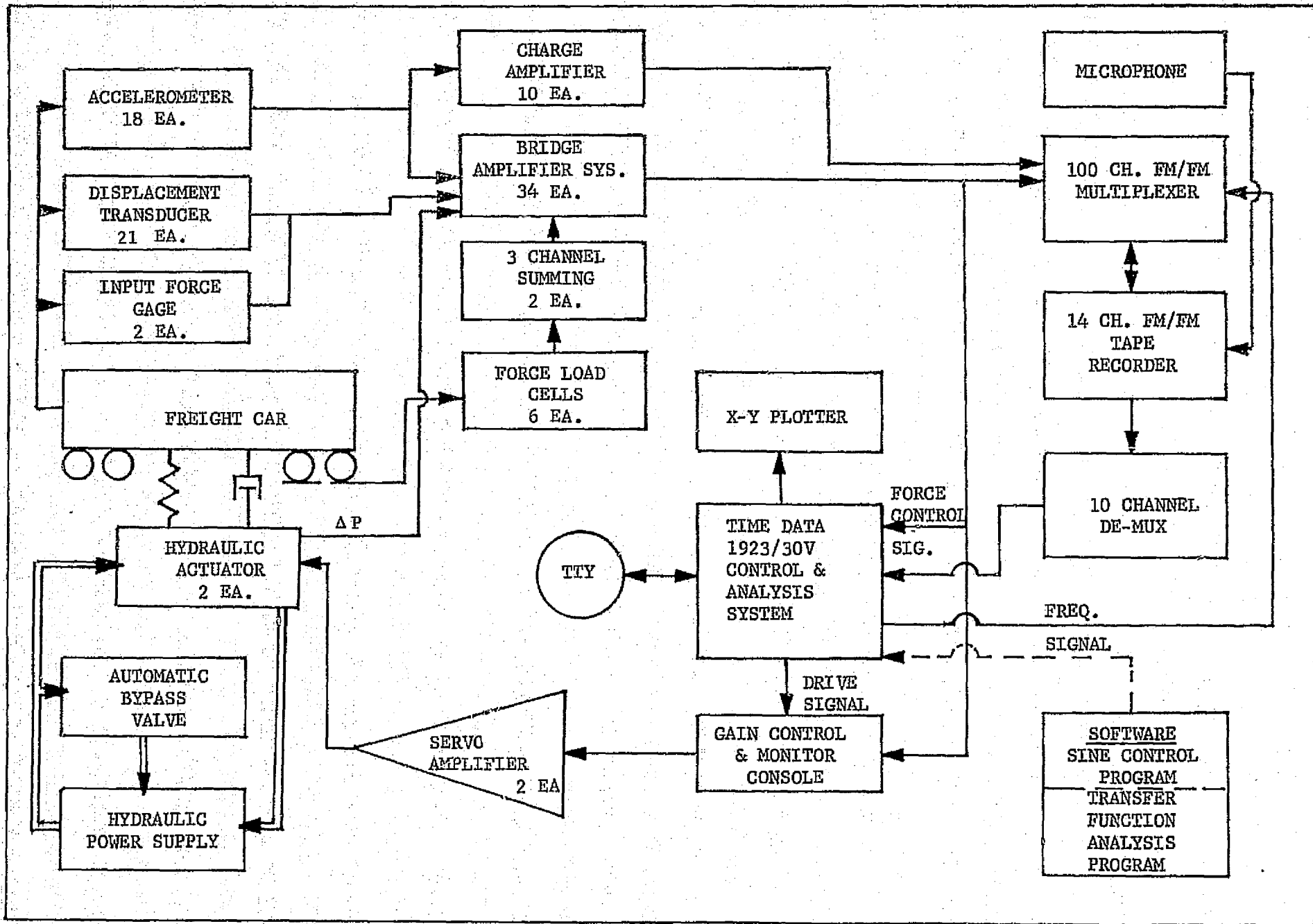

B43

R FIGURE 7.4 TEST INSTRUMENTATION & CONTROL SYSTEM BLOCK DIAGRAM

PRECEDING PAGE BLANK NOT FILMED

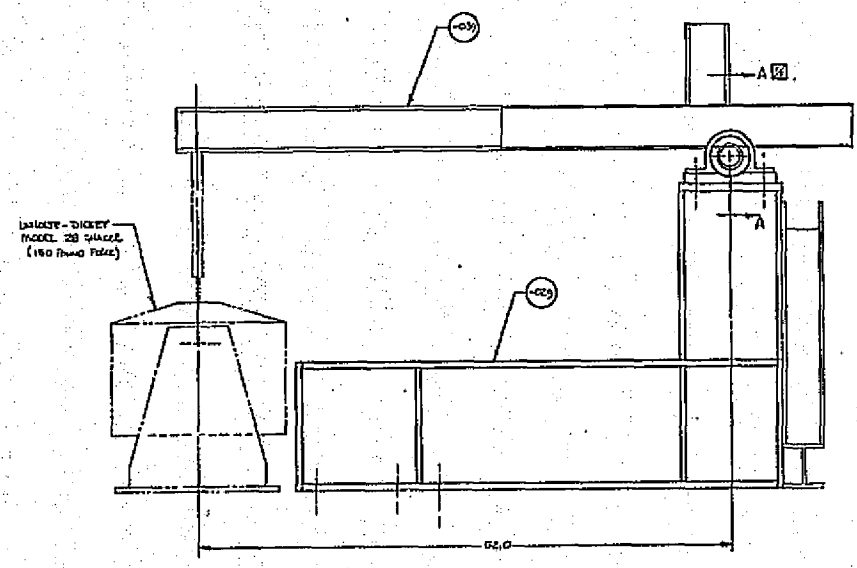
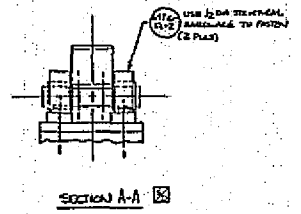

-049 ASSY 4REQ
SCALE 1/4"

NOTES:

1. BOND ALL SHARP EDGES AND CORNERS.
2. ALL WELDS MIN 1/16" MINIMUM.
3. LVDT DEFLECTION TRANSDUCERS ARE LOCATED PER TEST REQUIREMENTS DOCUMENT TR-005-17.
4. TWO NEW WIRE BONDS OF FRENCH GSI ANTISTATIC TINE ARE APPLIED TO #005 DOWEL GROUND THE WIRE TO FACILITY. THE LENGTH DIRECTION OF THE WIRE SHOULD BE PARALLEL TO TESTING DIRECTION. ALSO, ANTIWELD LUBE IS APPLIED BETWEEN SUBS PLATES (-005) AND STATIONARY BASE (-006, -005, -00)

REV	DESCRIPTION	DATE	BY	CHKD
1	ISSUED FOR FABRICATION			
2	REVISION			
3	REVISION			
4	REVISION			
5	REVISION			
6	REVISION			
7	REVISION			
8	REVISION			
9	REVISION			
10	REVISION			
11	REVISION			
12	REVISION			
13	REVISION			
14	REVISION			
15	REVISION			
16	REVISION			
17	REVISION			
18	REVISION			
19	REVISION			
20	REVISION			
21	REVISION			
22	REVISION			
23	REVISION			
24	REVISION			
25	REVISION			
26	REVISION			
27	REVISION			
28	REVISION			
29	REVISION			
30	REVISION			
31	REVISION			
32	REVISION			
33	REVISION			
34	REVISION			
35	REVISION			
36	REVISION			
37	REVISION			
38	REVISION			
39	REVISION			
40	REVISION			
41	REVISION			
42	REVISION			
43	REVISION			
44	REVISION			
45	REVISION			
46	REVISION			
47	REVISION			
48	REVISION			
49	REVISION			
50	REVISION			
51	REVISION			
52	REVISION			
53	REVISION			
54	REVISION			
55	REVISION			
56	REVISION			
57	REVISION			
58	REVISION			
59	REVISION			
60	REVISION			
61	REVISION			
62	REVISION			
63	REVISION			
64	REVISION			
65	REVISION			
66	REVISION			
67	REVISION			
68	REVISION			
69	REVISION			
70	REVISION			
71	REVISION			
72	REVISION			
73	REVISION			
74	REVISION			
75	REVISION			
76	REVISION			
77	REVISION			
78	REVISION			
79	REVISION			
80	REVISION			
81	REVISION			
82	REVISION			
83	REVISION			
84	REVISION			
85	REVISION			
86	REVISION			
87	REVISION			
88	REVISION			
89	REVISION			
90	REVISION			
91	REVISION			
92	REVISION			
93	REVISION			
94	REVISION			
95	REVISION			
96	REVISION			
97	REVISION			
98	REVISION			
99	REVISION			
100	REVISION			

<p>FIGURE 7.3 TEST FEATURES</p>	<p>04310</p> <p>LAB 1007302</p>	<p>TRACE - DYNAMIC ANALYSIS GUS & TENSILE FUNCTION</p>
---------------------------------	---------------------------------	--



-COIL DETAIL - 4 REQD
MATERIAL: ASTM A 36 STEEL

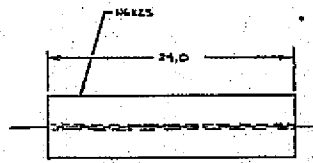

-COIL DETAIL - 8 REQD
MATERIAL: ASTM A 36 STEEL

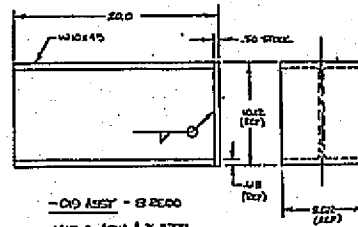

-COIL ASSY - 8 REQD
MATERIAL: ASTM A 36 STEEL

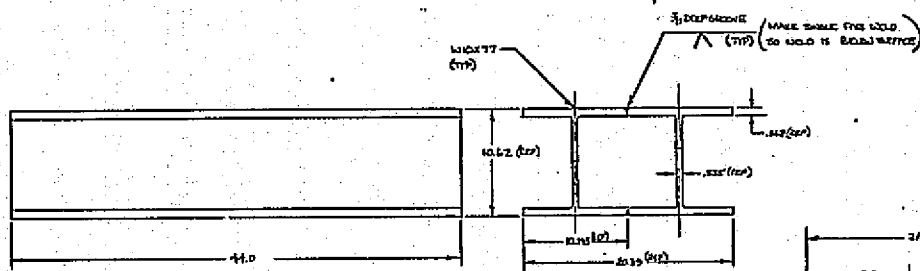

-COIL ASSY - 4 REQD
MATERIAL: ASTM A 36 STEEL

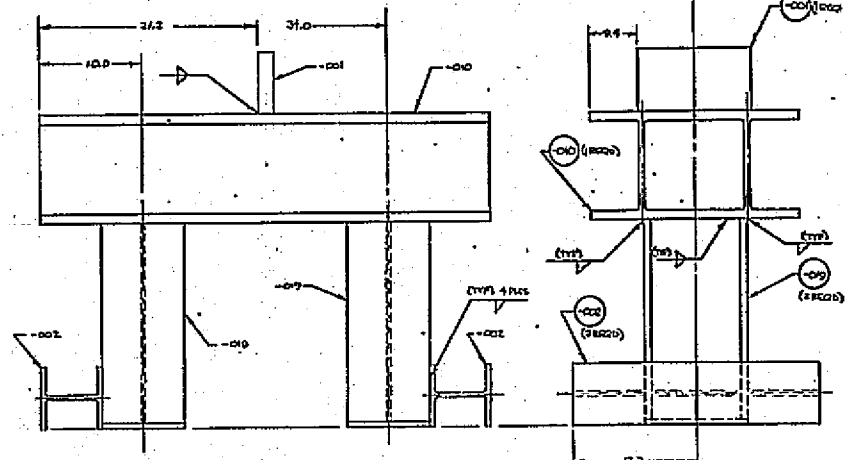

-COIL ASSY - 4 REQD

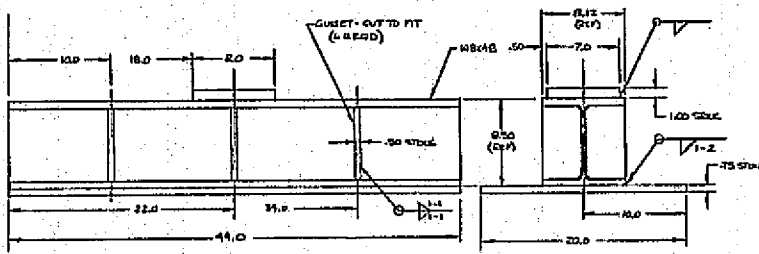

-COIL ASSY - 4 REQD
MATERIAL: ASTM A 36 STEEL

FIGURE 7.5 TEST FIXTURES
LAB 1001302

ORIGINAL PAGE IS
OF POOR QUALITY

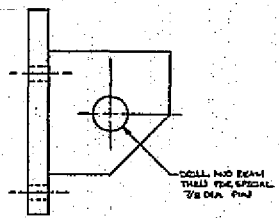

-040 ASSY (2 REQD)
MAKE FROM LAB100101-049
SCALE: FULL

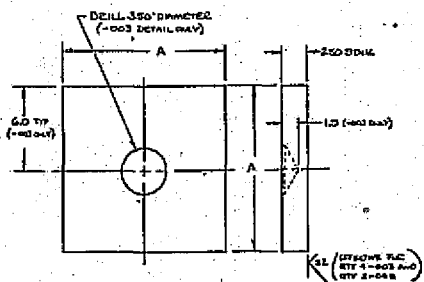

-003 DETAIL A = 12.0 (4 REQD)
-004 DETAIL A = 15.0 (1 REQD)
-007 DETAIL A = 16.0 (1 REQD)
-008 DETAIL A = 12.0 (4 REQD)

MATL: ASTM A36 STEEL
SCALE: NONE

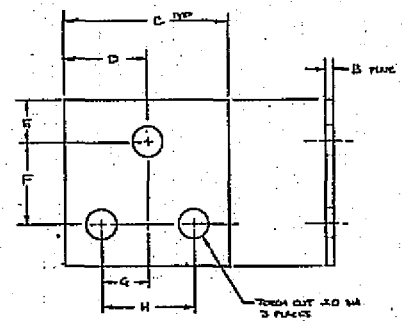

DETAIL	REQ	B	C	D	E	F	G	H
-005	1	1.50	1.80	9.0	3.0	5.87	5.70	8.40
-006	1	1.75	2.0	9.0	3.0	2.60	4.50	8.80

MATL: ASTM A36 STEEL
SCALE: NONE

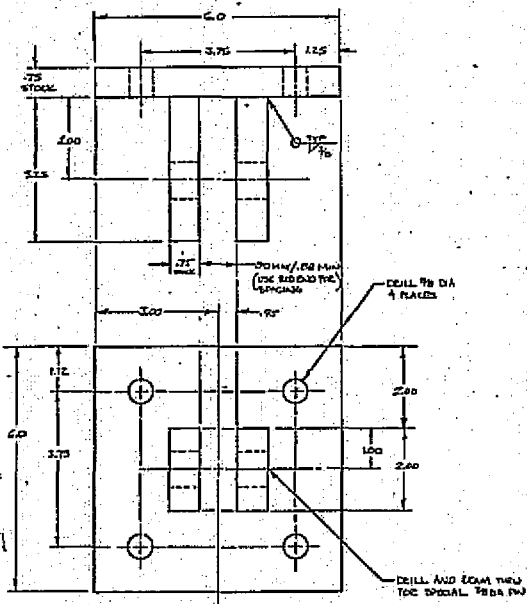

-050 ASSY 2 REQD
MATL: ASTM A36 STEEL
SCALE: FULL

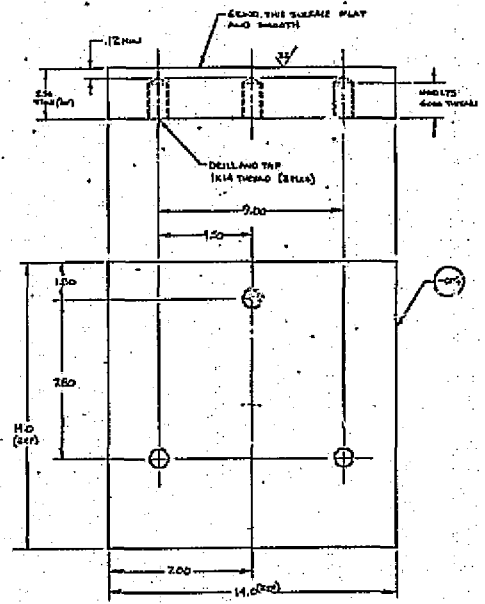

-060 ASSY (1 REQD)
SCALE: 1/2

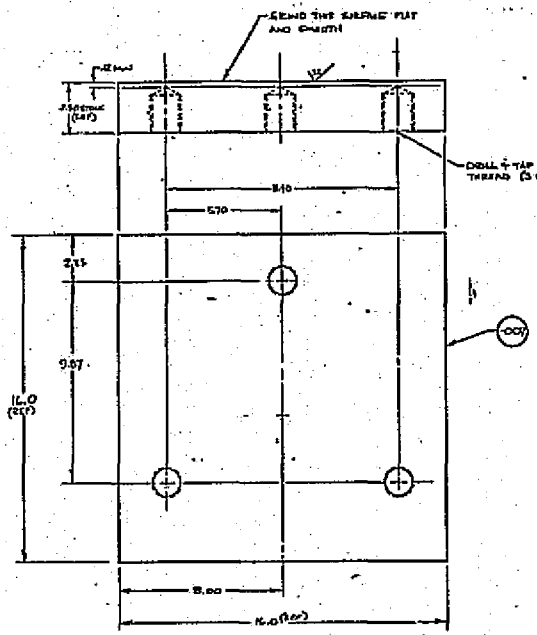

-070 ASSY (1 REQD)
SCALE: 1/2

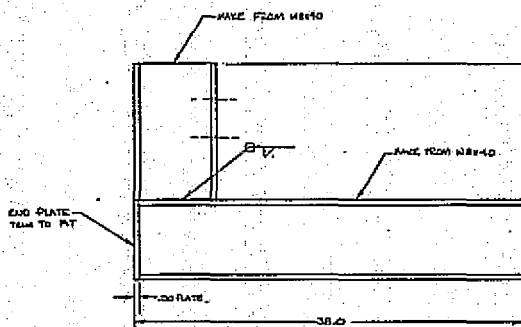

-080 ASSY (2 REQD)
MATERIAL ASTM A36 STEEL

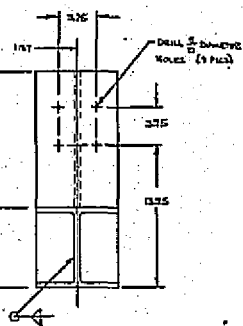

-059 ASSY (2 REQD)
MATERIAL ASTM A36 STEEL -WORK

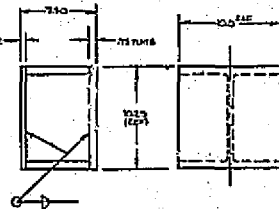
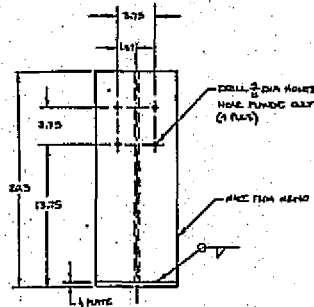

-016 DETAIL (4 REQD)
MATERIAL ASTM A36 STEEL

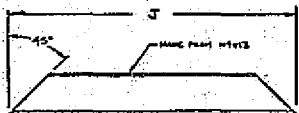

-012 DETAIL (6 REQD) J=11.0
-013 DETAIL (2 REQD) J=17.0
MATERIAL ASTM A36 STEEL -WORK

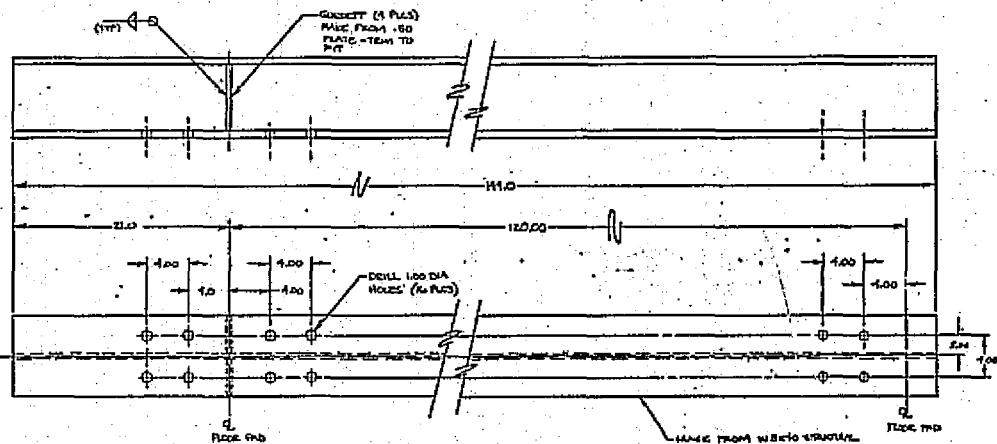

-079 ASSY (2 REQD)
MATERIAL ASTM A36 W8x40

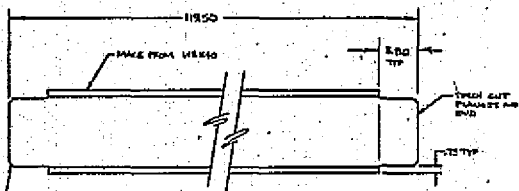

-011 DETAIL (5 REQD)
MATERIAL ASTM A36 STEEL -W8x40

ORIGINAL PAGE IS
OF POOR QUALITY

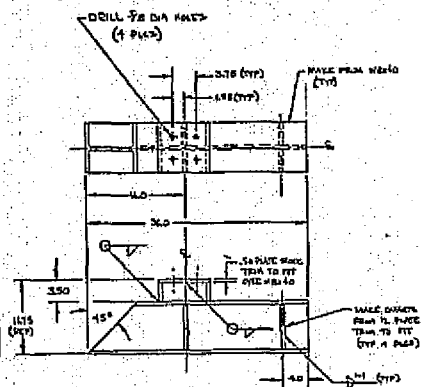

-DIT DETAIL (1 STEP)
MATERIAL: ASTM A53 STRUCTURAL

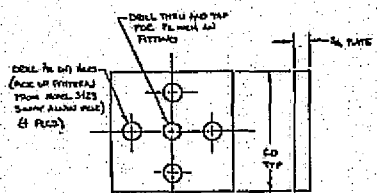

-DIB DETAIL (3 STEPS)
MATERIAL: 79 STRUCTURAL PLATE-A-16

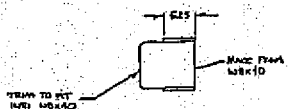

-DII DETAIL (2 STEPS)
MATERIAL: ASTM A53 STEEL

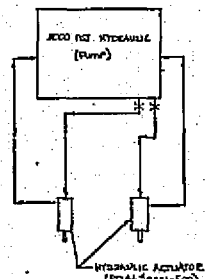

HYDRAULIC SCHEMATIC
Y AXIS TESTING (LATERAL)

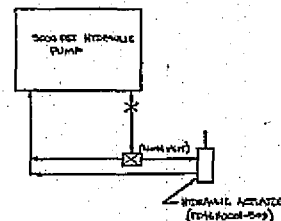

HYDRAULIC SCHEMATIC
Z AXIS TESTING (VERTICAL)

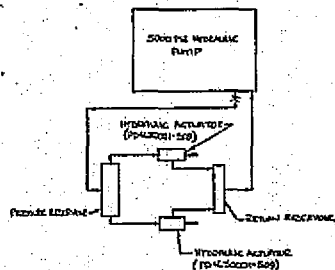

HYDRAULIC SCHEMATIC
X AXIS TESTING (LONGITUDINAL)

FIGURE 7.5 TEST FIXTURES

LAB1067302

B19

P. ENGINEERING

REV	DATE	BY	CHKD

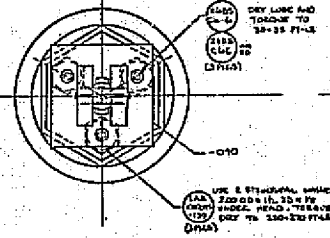

SPLIT B-B (TYPICAL FOR EACH ACTUATOR APPLICATION)

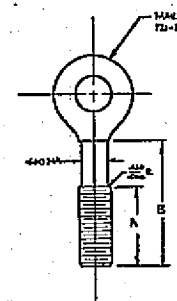
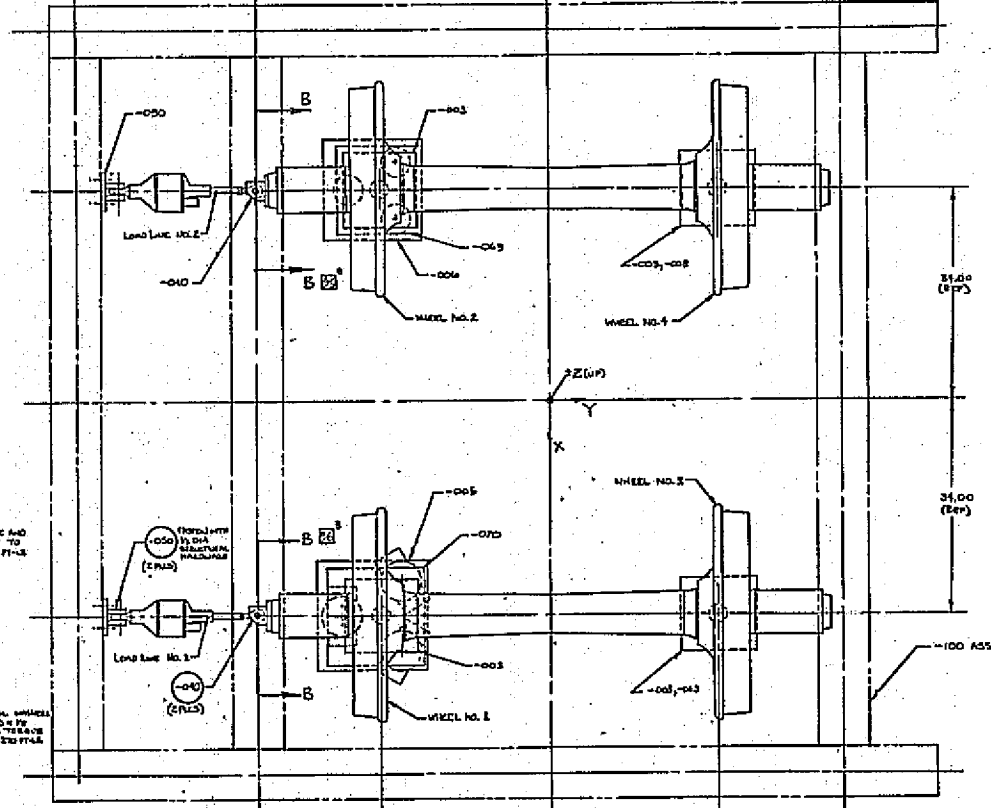

DEY	A	Z
-014	1.88	3.00
-015	2.00	2.70

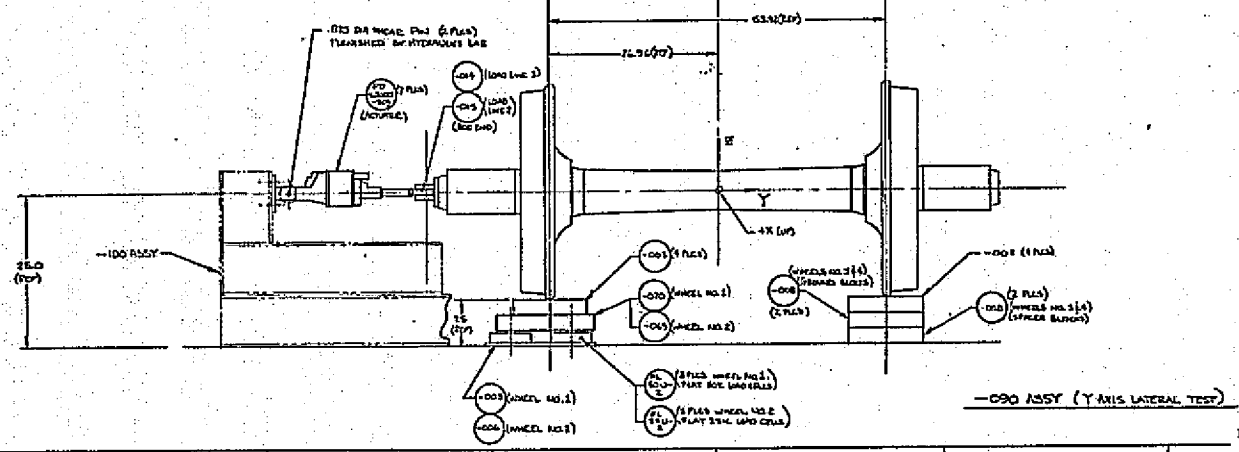

-090 ASSY (Y AXIS LATERAL TEST)

FIGURE 7.5 TEST FIXTURES

REV	DATE	BY	CHKD

LWS 100750 Z
 DATE: 10/11/01

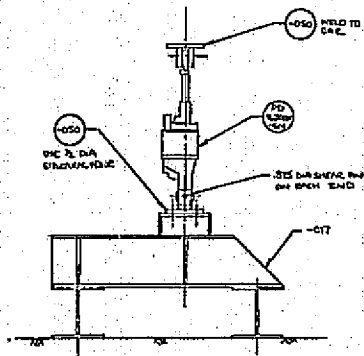

SECTION C-C (099 Assy ONLY)

NOTE: THIS FIXTURE WAS MOVED TO CENTER OF CAG SIDE ANGLE AND BOLTED TO FLOOR PLD.

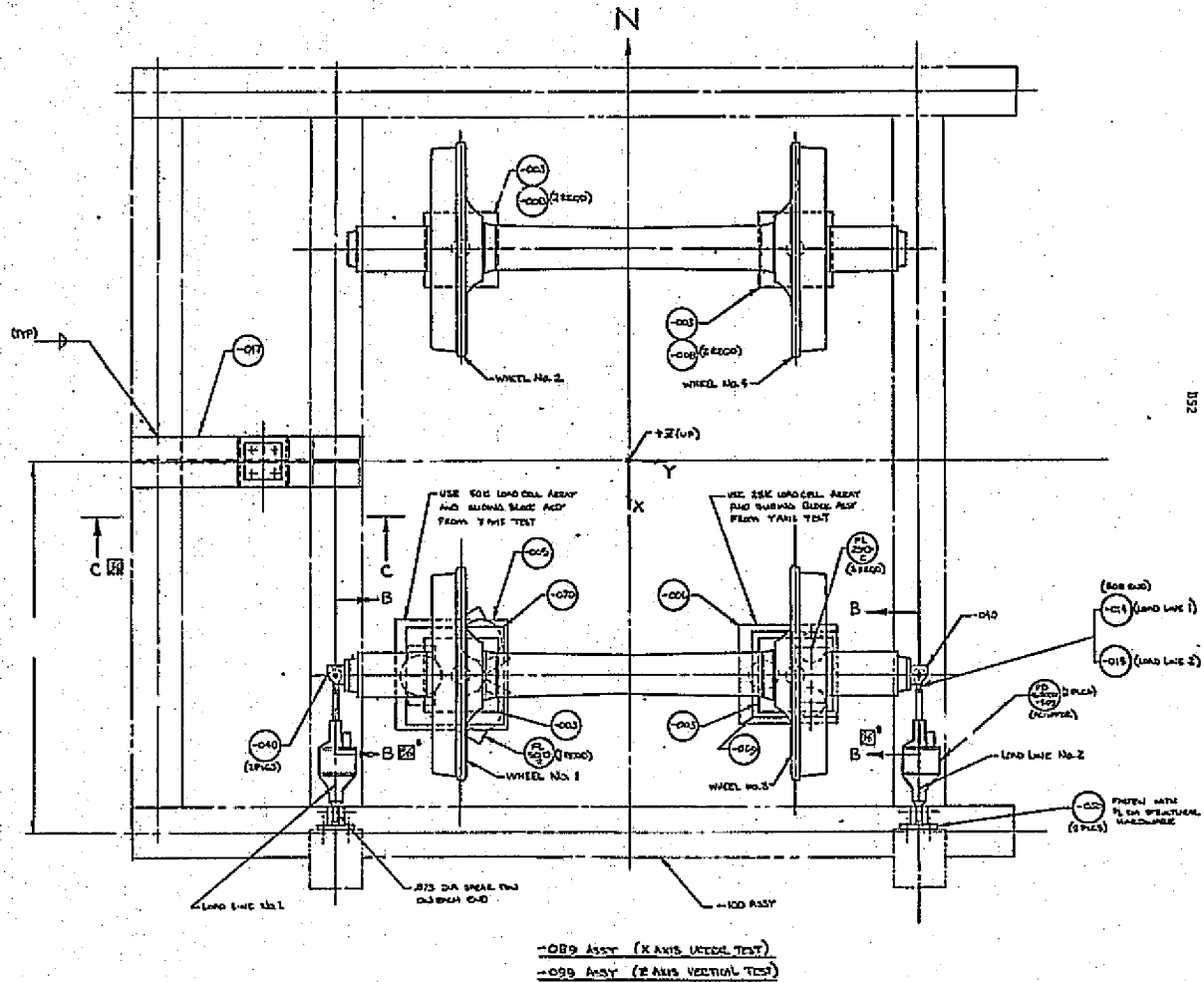

FIGURE 7.5 TEST FIXTURES

REV	DATE	LABIC07502

R Table 8.1 HANDLING EQUIPMENT

ITEM NO.	DESCRIPTION	MFG/MODEL NO.	QTY.
1	Facility Crane (20,000 lb. Cap.)	P&H	1
2	Facility Handling Slings and Harnesses	MMC	As Req'd
3	Hydraulic Jacks (100 Ton)	Regent	2
4	Coal Conveyor System	P&D	2
5	Coal Trucks		2
6	Hydraulic Jack (50 Ton)	Merrill	4

R Table 8.2 TEST EQUIPMENT

ITEM NO.	DESCRIPTION	MFG./MODEL NO.	QTY.
1	Computer (Shaker Control & Data Analysis)	Time Data/1923 30V	1
2	Shaker Gain Control & Monitor Console	MMC	1
3	Servo Amplifier	MMC	1
4	Hydraulic Actuator	Moog	2
5	Hydraulic Power Supply	Dennison	1
6	Actuator Support, Slide Plates & Truck Support Assemblies	MMC/LAB 1007302	1
7	Automatic Bypass Valve	Annin	1
8	Accelerometer	U-D/75 D 21	2
9	Accelerometer	Columbia/302-2	8
10	Accelerometer	Statham/A5a-2.0, 5.0,10.0-350	8
11	Displacement Transducers	SS-107 G.L.Collins SS-105	21
12	Load Cell	Strain sent Universal	6
13	Force Gage	MMC	2
14	Charge Amplifier	Kistler/505M111	10
15	Bridge Amplifier	Dana	34
16	Summing Amplifier	Dana	2
17	Tape Recorder (FM/FM)	Honeywell	1
18	Multiplexer	Vidar	1
19	De-Mux	Vidar	1
20	Cable (100 foot mini-noise)	Microdot	10
21	Equipment Interconnecting & Power Cables		As Req'd
22	Hydraulic Plumbing		As Req'd

R TABLE 8.3 TEST MEASUREMENT SUMMARY

MEAS. NO.	TRANSDUCER LOCATION	PURPOSE OF MEASUREMENT	SENS. AXIS
AV1	Car Left Side, Fwd. End	To Meas. Car Vert. (Z) & Roll (TX) Acceleration	Z
AV2	, Middle		
AV3	, Aft End		
AV4	Car Right Side, Fwd. End	↓	↓
AV5	, Middle		
AV6	, Aft End		
AL1	, Fwd. End	To Meas. Car Lateral (Y) Accelerations	Y
AL2	, Middle		
AL3	, Aft End		
AL4	Axle, Opposite Wheel 1	To Meas. Axle, (X) & (TZ) Accel.	X
AL5		, (Y) Accel.	-Y
AL6	Bolster, Left Side	To Meas. Bol., (X) & (TZ) Accel.	X
AL7		, (Y) Accel.	-Y
AL8	Axle, Opposite Wheel 2	To Meas. Axle, (X) & (TZ) Accel.	X
AL9		, (Y) Accel.	-Y
AL10	Axle, Opposite Wheel 3	, (X) & (TZ) Accel.	X
AL11	Bolster, Right Side	To Meas. Bol., (X) & (TZ) Accel.	↓
AL12	Axle, Opposite Wheel 4	To Meas. Axle, (X) & (TZ) Accel.	↓
DV1	Btwn. Bol. & Side Frame L. Side	To Meas. Rel. Displ. (Z)&(TX) of Bolster WRT Side Frame	Z
DV2	, Rt. Side		
DV3	Btwn. Bol. & Car Left Side		
DV4	, Rt. Side	To Meas. Rel. Displ. (Z) & (TX) of Bol. WRT Car	↓
DL1	Btwn. Bol. & Car Left Side	To Meas. Rel. Displ. (X) & (TZ) of Bol. WRT Car	X
DL2	, Rt. Side		
DL3	Center		
DL4	Btwn. S. Fr. & Axle, Wheel 1	To Meas. Rel. Displ. (Y) of Side Frame WRT Axle	↓
DL5	2	↓	↓
DL6	3		
DL7	4		
DL8	1	To Meas. Rel. Displ. (X) of Side Frame WRT Axle	X
DL9	2	↓	↓
DL10	3		
DL11	4		
DL12	Btwn. Bol. & Side Fr. L. Side	To Meas. Rel. Displ. (X) & (TZ) of Bol. WRT Side Frame	↓
DL13	, Rt. Side	To Meas. Rel. Displ. (Y) of Bol. WRT Side Frame	Y
DL14	, L. Side		
DL15	, Rt. Side		
FV1	Btwn. Actuator & Car L. Side	To Meas. Vert. (Z) Input Force	Z
FV2	Btwn. Wheel 1 & Facility Floor	To Meas. Vert. Force @ Wh. 1	↓
FV3	2	2	↓
FV4	3	3	↓
FL1	Btwn. Actuator & Axle, Opp. Wh. 1	To Meas. Lat. (Y) Input Force	Y
FL2	2	↓	↓
FL3	1		
FL4	3		
DL16	Btwn. S. Fr. & Wheel 1	To Meas. Rel. Displ. (Y) & (TZ) of S. Fr. WRT Wheel	Y
DL17	Wheel 3		
Δ P	Actuator No. 2	To meas. Diff. Press. Across Act. Piston	

R

Table 8.4 INSTRUMENTATION SETUP SHEET

MEAS. NO.	XDUCR MODEL NO.	XDUCR SENS.	SIG. COND. CH. NO.	TAPE CH. NO.	TAPE FS CALIB.	XDUCR S/N	CABLE NO.				
AV1	A5a-5-350	9.86mv/g	M1-3	2/14	1 g/v	7083	AV1				
AV2		9.66mv/g	M1-5	2/15		7077	AV2				
AV3		9.5 mv/g	M1-6	2/16		6467	AV3				
AV4		9.54mv/g	M1-7	2/17		7079	AV4				
AV5	A5a-2-350	23.9mv/g	M1-8	2/18		6587	AV5				
AV6		26.4mv/g	M1-9	2/19		4703	AV6				
AL1	A5a-5-350	9.2 mv/g	M1-10	3/24		7081	AL1				
AL2	A5a-10-350	4.8mv/g	M1-11	3/25		5732	AL2				
AL3	302-2	64.2mv/g	CA-1	3/26		3138	93/97				
AL4		77.8mv/g	CA-2	4/34		3248	178				
AL5		62 mv/g	CA-3	4/35		3136	177				
AL6		55.9mv/g	CA-4	3/27		3137	174				
AL7		81.7mv/g	CA-5	3/28		3249	179				
AL8		82.3mv/g	CA-6	4/36		3251	176				
AL9		63.2mv/g	CA-7	4/37		3135	119				
AL10		61 mv/g	CA-8	4/38		3139	91				
AL11	75D21	79.38mv/g	CA-9	3/29		421	92				
AL12	75D21	81.37mv/g	CA-10	4/39		423	171				

B56

R

Table 8.4 INSTRUMENTATION SETUP SHEET

MEAS.	XDUCR. MODEL NO.	XDUCR. SENS.	SIG. COND. CH. NO.	TAPE CH. NO.	TAPE FS CALIB.	XDUCR. S/N	CABLE NO.				
			Vidar/M-Cart		-						
DV1	SS-105	0.5 in/V	1/3-1	1/6	0.5 in/V	9692	1				
DV2	SS-107		2/3-2	1/7		19774	2				
DV3	SS-105		3/3-3	1/8		19647	3				
DV4	SS-107		4/3-4	1/9		19775	4				
DL1	SS-107		5/3-5	6/44		19639	5				
DL2	SS-107		6/3-6	6/45		19641	6				
DL3	SS-105		7/3-7	6/46		7850	7				
DL4	SS-107		8/3-8	6/47		19643	8				
DL5	SS-107		9/3-9	6/48		19771	9				
DL6	SS-107		10/3-10	6/49		19642	11				
DL7	SS-107		11/3-11	6/50		19772	10				
DL8	SS-107		12/3-12	7/54		19648	12				
DL9	SS-107		13/3-13	7/55		19646	13				
DL10	SS-107		14/3-14	7/56		19773	14				
DL11	SS-107		15/3-15	7/57		19640	15				
DL12	SS-107		16/4-1	8/64		19776	16				
DL13	SS-105		17/4-2	8/65		9304	17				
DL14	SS-107		18/4-3	8/66		19645	18				
DL15	SS-105		19/4-4	8/67		7847	19				
DL16	SS-105		20/4-5	8/68		7843	-				
DL17	SS-105		21/4-6	8/69		9305	-				

B57

R Table 8.4 INSTRUMENTATION SETUP SHEET

MEAS. NO.	XDUCR. MODEL NO.	XDUCR. SENS.	SIG. COND. CH. NO.	TAPE CH. NO.	TAPE FS CALIB.	XDUCR. S/N	CABLE NO.				
*FV1	MMC	15k #/V	1-1	1/1	15k #/V	F1	7				
FV2	Universal	20k #/V	2-4	1/4	20k #/V	671,672 673	1,2,3				
FV3	↓	↓	2-8	1/5	↓	665,666 667	4,5,6				
FV4	↓	↓	2-8	1/5	↓	665,666 667	4,5,6				
*FL1	MMC	15k #/V	1-1	1/1	15k #/V	F1	7				
*FL2	↓	↓	1-2	1/2	↓	F2	8				
*FL3	↓	↓	1-1	1/1	↓	F1	7				
*FL4	↓	↓	1-2	1/2	↓	F2	8				
Δ P	Moog	3500psi/V	1-12	3/30	3500psi/V	Actuator 2	-				
*OSC.	Rockland	.651V	-	1/3	.651V	-	-				
VOICE				14							
* These measurements were redundant on each tape track of each Mix Group											

Table 8.5 TEST HISTORICAL LOG

TIME	DATE	RUN NO.	TEST DESCRIPTION	REMARKS
			<u>Y-Axis Tests</u>	
	2/6/75		Test setup and system checkout	
	2/7/75		Moved wheel no. 1, 0.035" D.A. @ 0.5 Hz. Moved fixture opposite wheel no. 1, 0.050" D.A.	10,000 lbs-pk/actuator
	2/10/75		Lifted train and setup slide plates with one layer of tape. The tape was cut to eliminate cold flow ridges. Molydisulfide lubricant used.	
	2/11/75		Continued system checkout. Moved wheel no. 1 - 0.25" D.A. @ 0.5 Hz.	4,000 lbs-pk/actuator
	2/12/75		Continued computer closed loop operation. System not compatible with low frequency 0.5 Hz requirement.	Had low freq. and amp. control prob.
	2/13/75		DC coupled computer and completed setup and closed loop operation. Conducted sweeps with computer in test control loop. Raised freight car load off of wheel slide plate assemblies. Test discontinued pending instrumentation support.	2,000 lbs-pk/actuator 1-30 Hz. Single actuator control
	3/5/75		Instrumentation setup and checkout	Added DL16 and DL17
	3/6/75			
	3/7/75			
	3/10/75			
	3/11/75			

B59

Table 8.5 TEST HISTORICAL LOG

TIME	DATE	RUN NO.	TEST DESCRIPTION	REMARKS
			<u>Y-Axis Tests</u>	
1245	3/12/75	1	Sinewave Sweep: 0.5-35 Hz Test Level: 1995 lbs-pk, 6 db/oct below 1.98 Hz Actuator Phase: 180° ∅	Normal completion
1315		2	Sinewave Sweep (SS): 0.5-35 Hz Test Level (TL): 5010 lbs-pk, 6 db/oct below 1.98 Hz Actuator Phase (AP): 180° ∅	Normal completion accels. AL3-AL12 in cal. position
1400		3	Repeat Run 2	Normal completion
1415		4	SS: 0.5-35 Hz TL: 10,000 lbs-pk, 6 db/oct below 1.98 Hz AP: 180° ∅	Aborted @ 21.75 Hz
1450		5	Repeat Run 4	Aborted @ 23.27 Hz; reduced data on O-graphs
	3/13/75 & 3/14/75		Evaluated slide plate motion. Stiffened actuator fixture. Shimmed actuator rod ends.	
1515	3/18/75	6	SS: 0.5-50 Hz TL: 5000 lbs-pk AP: 180° ∅	Aborted @ 26.15 Hz
1530		7	SS: 0.5-50 Hz TL: 10,000 lbs-pk AP: 180° ∅	Aborted @ 0.5 Hz
1545		8	SS: 0.5-50 Hz TL: 10,000 lbs-pk, 6 db/oct below 1.98 Hz AP: 180° ∅	Aborted @ 2.361 Hz

Table 8.5 TEST HISTORICAL LOG

TIME	DATE	RUN NO.	TEST DESCRIPTION	REMARKS
			<u>Y-Axis Tests</u>	
1600	3/18/75	9	SS: 0.5-50 Hz TL: 7079.5 lbs-pk, 6 db/oct below 1.98 Hz AP: 180° \emptyset	Aborted @ 23.75 Hz
1000	3/19/75	10	Established max. force within actuator limits, i.e., 2" D.A., 8 "/sec, and 14,000 lbs-pk. SS: 0.5-50 Hz TL: 9000 lb-pk, 12 db/oct below 1.3 Hz AP: 180° \emptyset	Aborted @ 0.704 Hz
1005		11	SS: 0.5-50 Hz TL: 9000 lbs-pk, 12 db/oct below 1.3 Hz, 4495 lb-pk below 0.919 Hz AP: 180° \emptyset	Aborted @ 1.209 Hz
1015		12	Repeat Run 11 with 5 db tol. window.	Aborted @ 1.328 Hz
1245		13	SS: 0.5-50 Hz TL: 9000 lb-pk, linear below 1.3 Hz to 6000 lb-pk @ 0.5 Hz AP: 180° \emptyset	Aborted @ 37.95 Hz
1300		14	SS: 0.5-50 Hz TL: 4510.9 lb-pk, linear roll-off from 1.3 Hz to 3007.1 lb-pk @ 0.5 Hz AP: 180° \emptyset	Aborted @ 26.68 Hz; attempted to use dither on side frames prior to this test
1325		15	SS: 0.5-50 Hz TL: 4510.9 lb-pk, linear roll-off from 1.3 Hz to 3007.1 lb-pk @ 0.5 Hz AP: 0° \emptyset	Aborted @ 25.79 Hz
1335		16	Repeat Run 13 except AP = 0°	Aborted @ 0.633 Hz

Table 8.5 TEST HISTORICAL LOG

TIME	DATE	RUN NO.	TEST DESCRIPTION	REMARKS
			<u>Y-Axis Tests</u>	
1345	3/19/75	17	Repeat Run 16 with 6 db tol. window.	Aborted @ 1.254 Hz
1400		18	SS: 0.5-50 Hz TL: 6371.5 lbs-pk, linear roll-off from 1.3 Hz to 4247.7 lb-pk @ 0.5 Hz AP: 0° ∅	Aborted @ 32.14 Hz
1410		19	SS: 0.5-50 Hz TL: 8021.3 lbs-pk, linear roll-off from 1.3 Hz to 5347.5 lbs-pk @ 0.5 Hz AP: 0° ∅	Aborted @ 26.9 Hz
950	3/20/75	20	SS: 0.5-50 Hz TL: 8021.3 lbs-pk, linear roll-off from 1.3 Hz to 5347.5 lbs-pk @ 0.5 Hz AP: 0° ∅	Aborted @ 27.39 Hz; reduced ΔP gain by a factor of 2 for this test and subs; movies taken.
1010		21	Repeat of Run No. 20; AP = 0° ∅	Aborted @ 27.34 Hz
1030		22	Repeat of Run No. 13; AP = 180° ∅; 9000 lbs	Aborted @ 2.104 Hz
1050		23	SS: 0.5-50 Hz TL: 8021.3 lbs-pk, linear roll-off from 1.3 Hz to 5347.5 lbs-pk @ 0.5 Hz AP: 180° ∅	Aborted @ 34.93 Hz
1105		24	Repeat of Run No. 20; AP = 0° ∅	Aborted @ 1.403 Hz
1120		25	SS: 0.5-50 Hz TL: 6370 lbs-pk, linear roll-off from 1.3 Hz to 4250 lbs-pk @ 0.5 Hz AP: 0° ∅	Aborted @ 7.844 Hz; abort initiated; ran manual levels @ 1.3 & 1.8 Hz @ 10K lbs & 12K lbs to demonstrate motion

Table 8.5 TEST HISTORICAL LOG

TIME	DATE	RUN NO.	TEST DESCRIPTION	REMARKS
			<u>Y-Axis Tests</u>	
1120	3/20/75	25	Repeat of Run 20; AP = 0° ∅; Test abort initiated 20 Hz	Data not recorded; demonstration test
1322			SS: 0.5-50 Hz TL: 7140 lbs-pk, linear roll-off from 1.3 Hz to 4770 lbs-pk @ 0.5 Hz AP: 0° ∅	Aborted @ 22.04 Hz; data not recorded; abort ini- tiated; demonstration test
			<u>X-Axis Tests</u>	
1345	3/25/75	26	SS: 0.5-50 Hz TL: 4510 lbs-pk, linear roll-off from 1.2 Hz to 3050 lbs-pk @ 0.5 Hz AP: 180° ∅	During manual operation FL3 was found to be intermittant & traced to a shorted wire. Normal completion
1437		27	SS: 0.5-50 Hz TL: 7150 lbs-pk, linear roll-off from 1.3 Hz to 4760 lbs-pk @ 0.5 Hz AP: 180° ∅	Aborted @ 1.606 Hz
1445		28	SS: 0.5-50 Hz TL: 6750 lbs-pk, linear roll-off from 1.3 Hz to 4500 lbs-pk @ 0.5 Hz AP: 180° ∅	Aborted @ 3.226 Hz
1505		29	SS: 0.5-50 Hz TL: 6360 lbs-pk, linear roll-off from 1.3 Hz to 4250 lbs-pk @ 0.5 Hz AP: 180° ∅	Aborted @ 21.59 Hz
1000	3/26/75	30	SS: 0.5-50 Hz TL: 6010 lbs-pk linear roll-off below 1.3 Hz to 4010 lbs-pk @ 0.5 Hz AP: 180° ∅	Aborted @ 36.99 Hz; FL3 = 272 mvrms; FL4 = 290 mvrms; Levels below clip

Table 8.5 TEST HISTORICAL LOG

TIME	DATE	RUN NO.	TEST DESCRIPTION	REMARKS
			<u>X-Axis Tests</u>	
1020	3/26/75	31	SS: 0.5-50 Hz TL: 4510 lbs-pk, linear roll-off below 1.3 Hz to 3010 lbs-pk @ 0.5 Hz AP: 0° ∅	Aborted @ 2.088 Hz
1030		32	SS: 0.5-50 Hz TL: 4020 lbs-pk, linear roll-off below 1.3 Hz to 2680 lbs-pk @ 0.5 Hz AP: 0° ∅	Aborted @ 2.026 Hz
1100		33	SS: 0.5-50 Hz TL: 2540 lbs-pk, linear roll-off below 1.3 Hz to 1691 lbs-pk @ 0.5 Hz AP: 0° ∅	Aborted @ 25.98 Hz
			<u>Z-Axis Tests</u>	
1030	3/28/75	34	SS: 0.5-50 Hz TL: 5010 lb-pk	Aborted @ 0.5 Hz; abort initiated 1923 was AC coupled
1045		35	Repeat of Run 34	Aborted @ 1.244 Hz
1250		36	SS: 0.5-50 Hz TL: 5000 lb-pk, 12 db/oct below 4.2 Hz to 3 Hz, 2500 lb-pk below 3 Hz	Aborted @ 1.411 Hz
1300		37	SS: 0.5-50 Hz TL: 5000 lb-pk, 12 db/oct below 4.76 Hz to 3 Hz, 1990 lb-pk below 3 Hz	Aborted @ 1.425 Hz
1310		38	SS: 0.5-50 Hz TL: 5000 lb-pk, 12 db/oct below 9.49 Hz, 500 lb-pk below 3 Hz	Aborted @ 0.737 Hz

Table 8.5 TEST HISTORICAL LOG

TIME	DATE	RUN NO.	TEST DESCRIPTION	REMARKS
			<u>Z-Axis Tests</u>	
1315	3/28/75	39	Repeat of Run 38; zeroed force	Aborted @ 4.014 Hz
1400		40	Repeat of Run 39; changed force sensitivity to .7500 lb/V	Aborted @ 3.864 Hz
1440		41	SS: 0.5-50 Hz TL: 1995 lb-pk Changed force sensitivity to 4000 lb/V	Aborted @ 1.318 Hz
1450		42	Repeat of Run 41 @ 1000 lb-pk	Aborted @ 0.542 Hz
1500		43	Repeat of Run 42, 1000 lb-pk	Aborted @ 0.986 Hz
1515			Repeat of Run 43; <u>test not recorded</u>	Aborted @ 0.644 Hz
1000	3/31/75	44	SS: 0.5-50 Hz TL: 3980 lbs-pk, linear roll-off from 5 Hz to 1999 lbs-pk @ 0.5 Hz Changed force sens. to 15,000 lb/V	Aborted @ 32.26 Hz
1015		45	SS: 0.5-50 Hz TL: 5010 lbs-pk, linear roll-off from 5 Hz to 3540 lbs-pk @ 0.5 Hz	Aborted @ 27.29 Hz
1045		46	SS: 0.5-50 Hz TL: 5010 lbs-pk	Aborted @ 27.58 Hz
	4/1/75		Movies taken for Z and X axis tests. Constant voltage input	
	4/2/75 4/3/75		Completed data reduction on Run 20 and Run 46	
	4/4/75		Started data reduction on Run 23	

Table 8.5 TEST HISTORICAL LOG

TIME	DATE	RUN NO.	TEST DESCRIPTION	REMARKS
	4/7/75		<u>Post-Test</u> Began disassembly of test setup. Completed data reduction of Run 23. Started data reduction on Run 6	
	4/8/75		Completed data reduction of Run 6. Started data reduction of Run 9. Finished test disassembly-instrumentation	
	4/10/75		Completed data reduction of Run 9. Started data reduction of Run 13	
	4/11/75		Completed data reduction on Run 13 60 Hz fold-over problem Started data reduction of Run 14	
	4/14/75		Completed data reduction on Run 14. Started data reduction on Run 15	
	4/15/75		Completed data reduction on Run 15. Started data reduction on Run 18	
	4/16/75		Completed data reduction on Run 18. Started data reduction on Run 19	
	4/17/75		Completed data reduction on Run 19. Started O-graph data reduction on 20 and 23	
	4/18/75		Completed O-graph data reduction on Runs 20 and 23	
	5/19/75		Started unloading coal	
	5/22/75		Completed unloading coal	

TABLE 8.6

TRANSFER FUNCTION-DEFLECTION COORDINATES

<u>Meas.</u> <u>No.</u>	<u>X</u>	<u>Y</u>	<u>Z</u>
DV1	0.	-48 3/4	-
DV2	0.	48 3/4	-
DV3	0.	-30 3/8	-
DV4	0.	30 3/8	-
DL1	-	-30.0	13 5/8
DL2	-	30 3/8	13 3/8
DL3	12 7/8	-	4 5/8
DL4	34.0	-	13 5/8
DL5	-34.0	-	13 5/8
DL6	34.0	-	13 5/8
DL7	-34.0	-	13 5/8
DL8	-	-32 1/2	0.
DL9	-	-32 11/16	0.
DL10	-	32 1/4	0.
DL11	-	32 11/16	0.
DL12	-	-41 3/8	7 1/2
DL13	-	41 5/8	7 3/8
DL14	-	0.	14 5/8
DL15	-	0.	13 7/8
DL16	62 3/4	-	0.0
DL17	61 5/8	-	3/8

NOTE: FOR (0,0,0) SEE FIGURE 7.3