

General Disclaimer

One or more of the Following Statements may affect this Document

- This document has been reproduced from the best copy furnished by the organizational source. It is being released in the interest of making available as much information as possible.
- This document may contain data, which exceeds the sheet parameters. It was furnished in this condition by the organizational source and is the best copy available.
- This document may contain tone-on-tone or color graphs, charts and/or pictures, which have been reproduced in black and white.
- This document is paginated as submitted by the original source.
- Portions of this document are not fully legible due to the historical nature of some of the material. However, it is the best reproduction available from the original submission.

NASA CR-144007

(NASA-CR-144007) MULTIPURPOSE PANEL, PHASE
1, STUDY REPORT (Bendix Corp.) 23 P CSCL 14B
HC \$3.25

Unclas
G3/19 39976



Flight Systems
Division

1.0 SUMMARY

There is presently a need for a flexible control panel that can be programmed to satisfy the requirements of many unrelated but similar systems. In this report a practical approach to this problem is presented as are the results of an investigation into the present and anticipated developments in the field of electronic displays that make such a concept now possible.

MULTI PURPOSE
PANEL

PHASE I

STUDY REPORT

PREPARED FOR
GEORGE C. MARSHALL
SPACE FLIGHT CENTER
NATIONAL
AERONAUTICS AND
SPACE ADMINISTRATION

CONTRACT NUMBER
NAS8-31286

DCN NUMBER
1-5-57-5302

PREPARED BY
THE BENDIX
CORPORATION
FLIGHT SYSTEMS
DIVISION
TETERBORO,
NEW JERSEY

DOCUMENT NUMBER
7411-006-75-18

MAY 1975

MULTIPURPOSE PANEL

PHASE I

STUDY REPORT

CONTRACT NUMBER

NAS8-31286

DCN NUMBER

1-5-57-53021

PREPARED FOR

GEORGE C. MARSHALL SPACE FLIGHT CENTER
NATIONAL AERONAUTICS AND SPACE ADMINISTRATION
HUNTSVILLE, ALABAMA

PREPARED BY

THE BENDIX CORPORATION
FLIGHT SYSTEMS DIVISION
TETERBORO, NEW JERSEY

DOCUMENT NUMBER

7411-006-75-18

William Parkin

William Parkin
Senior Staff Engineer

Kenneth Kendall

Kenneth Kendall
Supervisory Engineer
Flight Data and Displays

FOREWORD

This report is submitted to the Marshall Space Flight Center by The Bendix Corporation, Flight Systems Division in response to Phase I of Contract NAS8-31286.

TABLE OF CONTENTS

SECTION	TITLE	PAGE
1.0	SUMMARY	1-1
2.0	MULTIPURPOSE PANEL PROGRAM	2-1
3.0	MULTIPURPOSE PANEL CONCEPT	3-1
3.1	MEMORY	3-3
3.2	SUBSYSTEM SELECTOR	3-5
3.3	ALPHANUMERIC DISPLAYS	3-5
4.0	ALPHANUMERIC DISPLAY DEVICES	4-1
4.1	CURRENT DISPLAY TECHNOLOGY TECHNOLOGY	4-2
4.1.1	Light Emitting Diodes	4-2
4.1.2	Plasma Displays	4-4
4.1.2.1	DC Plasma Displays	4-5
4.1.2.2	AC Plasma Displays	4-6
4.1.3	Other Devices	4-7
4.1.3.1	Flat Panel CRT	4-7
4.1.3.2	Incandescent Displays	4-8
4.1.3.3	Liquid Crystal	4-8
4.2	FUTURE DEVELOPMENTS	4-8
4.2.1	Improved Plasma Displays	4-9
4.2.2	Electroluminescent Displays	4-9
4.2.3	Ferroelectric Ceramic Displays	4-10
4.3	CONCLUSIONS AND RECOMMENDATIONS	4-10

1.0 **SUMMARY**

There is presently a need for a flexible control panel that can be programmed to satisfy the requirements of many unrelated but similar systems. In this report a practical approach to this problem is presented as are the results of an investigation into the present and anticipated developments in the field of electronic displays that make such a concept now possible.

2.0 MULTIPURPOSE PANEL PROGRAM

During the ATM Control and Display effort in the Skylab Program, some shortcomings of a large scale dedicated C and D panel were encountered. The impact of panel changes resulting from refinements of the various subsystems was of primary concern. The modification of panel wiring and nomenclature at the many system development stages was both time consuming and costly. Another significant problem was human error created by grouping many similar experiments together. The operator would tend to be confused by nearly identical controls located near each other.

To overcome these problems, a Multipurpose Panel is being considered. Under this concept, a large scale control and display panel for a number of similar subsystems or experiments would be replaced by a single small scale panel capable of being programmed to provide the control and display requirements of each subsystem upon request. The basic functions of the Multipurpose Panel would be to provide a programmable electronic display for changeable panel nomenclature, to multiplex similar indicator display signals to the single display, and to demultiplex command signals.

The development of a field programmable Multipurpose Panel will reduce panel nomenclature and functional changes to the replacement of memory devices. The Multipurpose Panel will also eliminate confusion among similar controls and displays, since only one subsystem will be activated at a time. It will also result in space savings, and will reduce the panel operator's viewing area.

The fabrication of a Multipurpose Panel is made practical at this time by a number of recent developments. The evolution of electronic display technology in recent years now allows us to seriously consider the concept of changeable panel nomenclature. The maturation of miniaturized electronic and memory devices gives us the flexibility, compactness, and economy required to consider the Multipurpose Panel as a viable alternative to dedicated control and display panels. The Multipurpose Panel is compatible with the trend toward sophisticated Data Management Systems where digital address and multiplexing are central features. Finally, projected as a concept to be applied in the Space Shuttle Payload Station, the Multipurpose Panel would provide the flexibility required for such a mission.

The Multipurpose Panel Program is an effort to determine the feasibility of such a concept. The program is divided into four phases. The initial phase, which is the subject of this report, is a study phase to investigate the possibility of constructing such a panel. Activity during this part of the program is focused on developing the Multipurpose Panel concept and determining the availability of the display devices necessary to meet the program requirements. The study phase will be followed by a design effort and a fabrication effort toward providing a demonstration model, and the program will be concluded by a period of demonstration.

3.0 MULTIPURPOSE PANEL CONCEPT

As mentioned previously, the three basic functions to be provided by the Multipurpose Panel are changeable panel nomenclature, the multiplexing of display signals, and the demultiplexing of switch commands. Due to the similarity between the multiplexing and demultiplexing operations, and since display signal sources will usually not be available during demonstration, the switch panel shown in Figure 1 will serve to verify the Multipurpose Panel concept.

The panel layout has been arranged to duplicate an actual control panel situation. The upper portion of the panel is the actual Multipurpose Display. The block of toggle switches was selected to simulate close component positioning. The rotary switch was included to present the nomenclature spacing unique to that component. Two sizes of displays have been provided for the addressable nomenclature, .27 inch high characters for panel component groupings, and .15 inch high characters for individual component nomenclature. The lower portion of the panel is the manual control section for activating the Multipurpose Display. It has been included on the front panel face to provide a comparison between the Multipurpose Panel and conventional control panel appearance.

The panel color will be gray to be consistent with MSFC crew station requirements. For reasons that will be explained in the next section of the report, the addressable panel nomenclature located on the upper portion will be provided by red light emitting diode matrix arrays. The controls on the lower portion of the panel will be labeled with white nomenclature in accordance with MSFC standards.



MULTI-PURPOSE PANEL

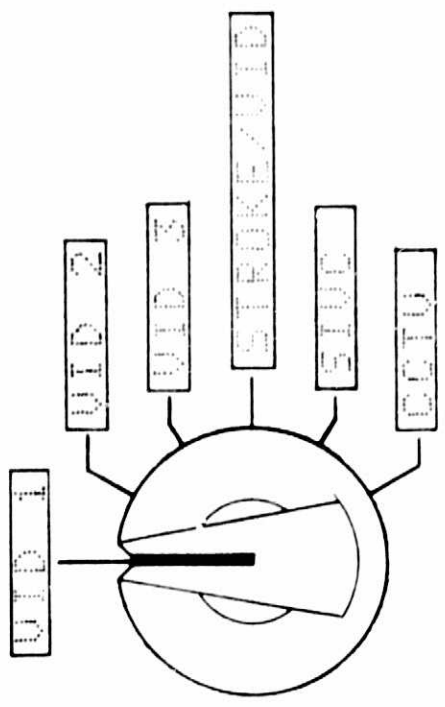
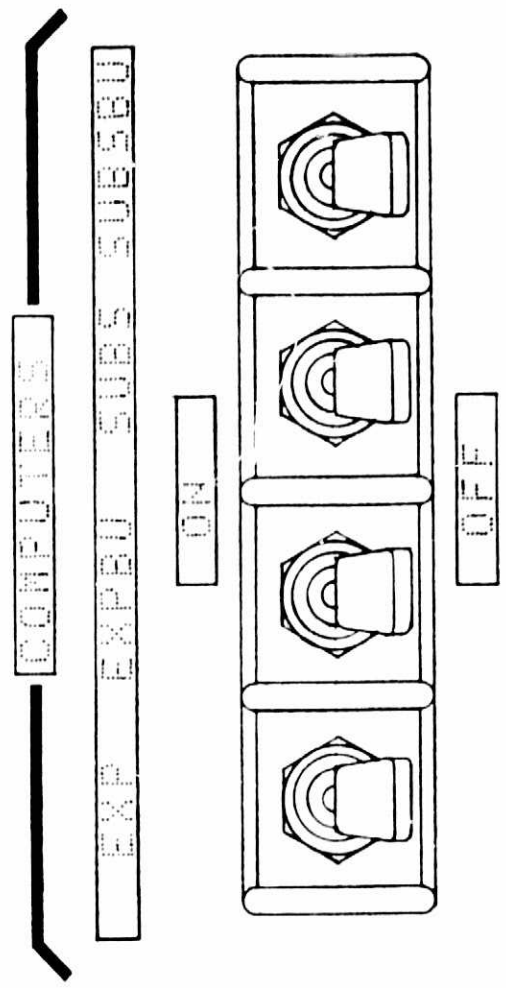

DISPLAY PANEL CONTROLS

DISPLAY SELECT

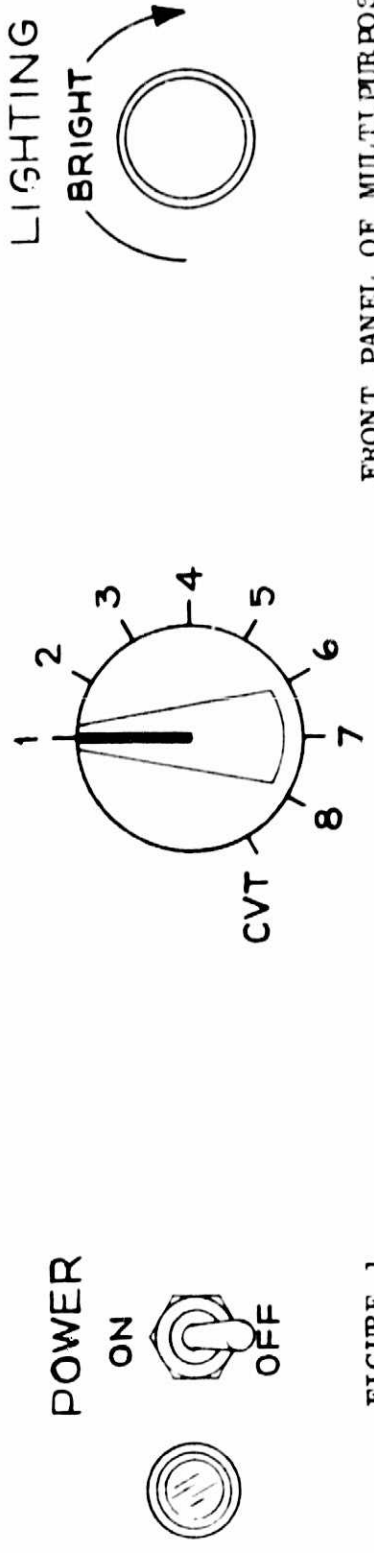

FRONT PANEL OF MULTI-PURPOSE PANEL

FIGURE 1

Figure 2 is a block diagram of the electronics section of the Multipurpose Panel. Information pertaining to panel nomenclature and command switch outputs is stored in PROM's 1 through 8. Each PROM contains all the information required for a particular subsystems. Thus an entire subsystem may be changed or parts of any subsystem can be changed simply by replacing a PROM. The subsystem to be controlled is selected by either a manual selector switch or by an address from the Digital Interface Unit of the MSFC CVT System. The respective panel nomenclature and command signal lines for that system will then be activated. The interface with the CVT system will consist of a 3 parallel line digital command for display selection, and a number of discrete switch command outputs. A more detailed description of the functional blocks follows.

3.1 MEMORY

The eight replaceable PROM's will each be 1048 by 1 bit memories. This will provide enough capability to store data for 100 characters in ASCII format and to enable or disable the appropriate command switches. This configuration is necessary for a demonstration model of the Multipurpose Panel since a tie in to the CVT System may not be feasible for demonstrations. It is also a much more practical alternative than obtaining the required data via digital word transmission from the CVT Systems directly since it would simplify the DIU interface considerably. It would also free the CVT System from needlessly being loaded with repetitive routine data, or it would prevent power interrupt problems that would result if CVT System data were stored in a RAM.

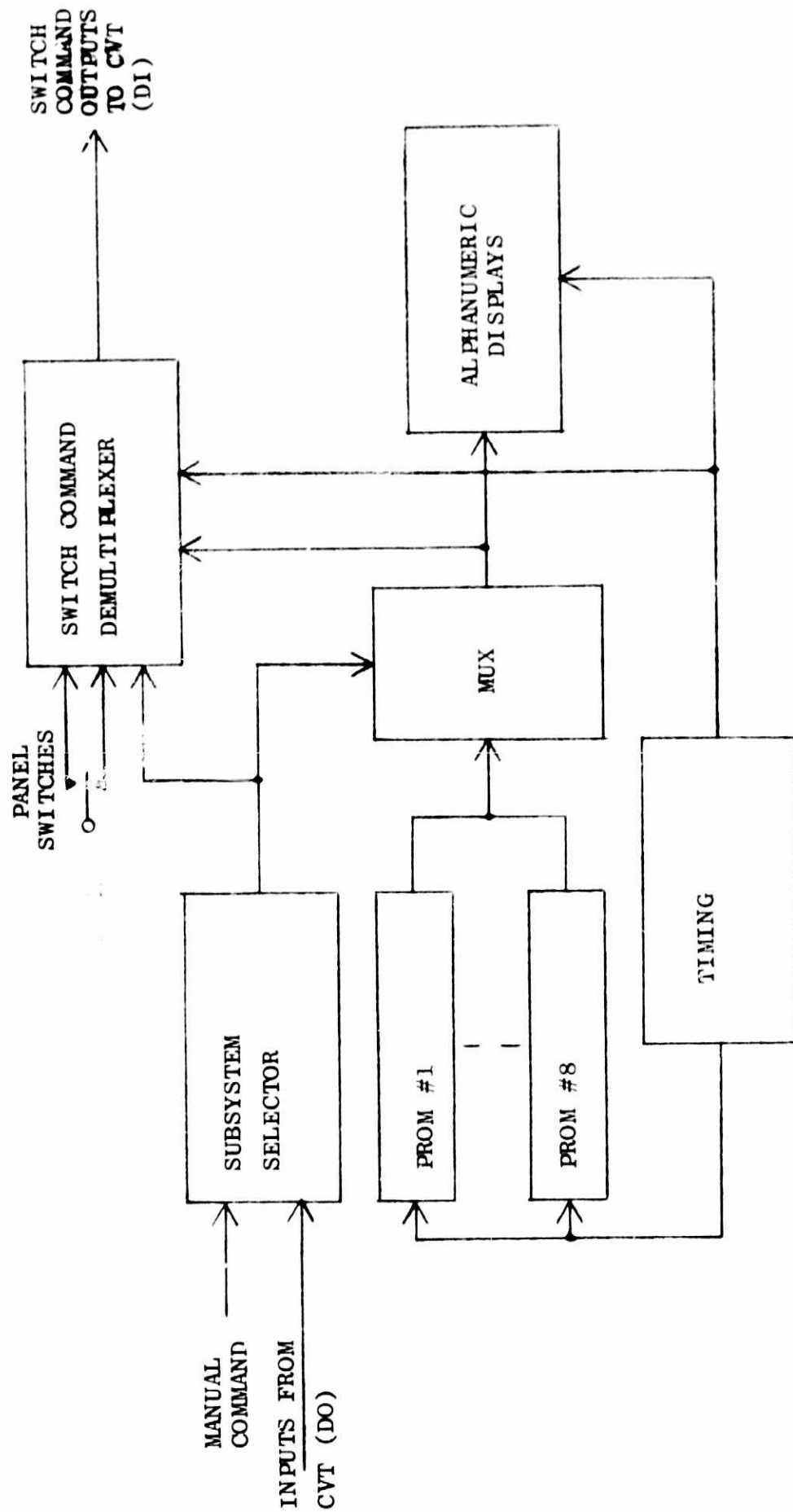

FIGURE 2
BLOCK DIAGRAM OF MULTIPURPOSE PANEL

3.2 SUBSYSTEM SELECTOR

The Subsystem Selector decodes manual selector switch commands and a 3 bit digital signal from the CVT System. It then addresses the memory multiplexer and the command switch demultiplexer to select one of the eight subsystems to be controlled. The choice of a capacity of 8 subsystems is arbitrary and has been selected to minimize hardware cost and complexity. Eight subsystems should be adequate for any foreseeable applications, but should the need for more capacity arise, the Multipurpose Panel can be readily expanded.

3.3 ALPHANUMERIC DISPLAYS

The alphanumeric displays will be examined in detail in the following section, but for the purposes of this discussion, the displays can be briefly described as 5 X 7 LED matrices. There will be a mix of approximately 100 characters with heights of .15 inch and .27 inch. The characters will be red in color in order to make use of existing devices. The LED address data will be multiplexed in order to simplify the decoding and driver circuitry and to obtain more efficient LED light output.

The multiplexing scheme to be used is shown in Figure 3. The characters will be divided into two groups of 50 characters, and each row of these groups will be addressed in sequence. This will require cycling through 14 different rows of diodes, or multiplexing at a duty cycle of 1/14. Display information for each of these rows will be provided by clocking the ASCII data from the selected PROM, decoding this information by means of a 2240 bit ROM into a 5 bit word for each row of each character, and accumulating the 250 bits of column data for each row. This information is then transferred to a storage register for display.

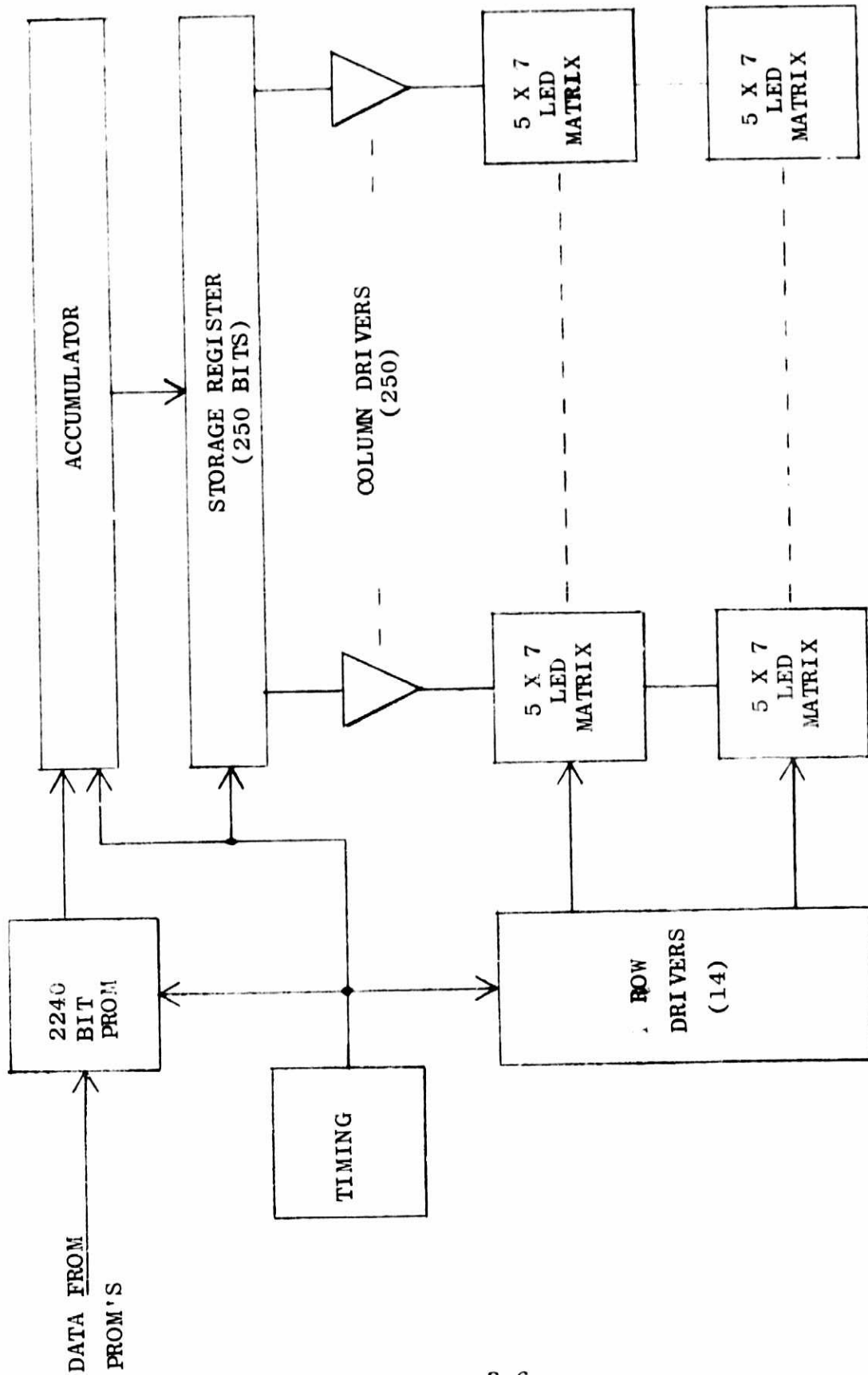

MULTIPLYING OF LED'S

FIGURE 3

4.0 ALPHANUMERIC DISPLAY DEVICES

Perhaps the most critical factor in determining the feasibility of the Multipurpose Panel is the ability to change panel nomenclature on command. In order to be consistent with existing human factors standards, and in order to maintain relatively compact control and display densities, size becomes the limiting factor. Character height must be between 1/8 and 1/4 of an inch, and character spacing must provide for good legend legibility. Other important factors which will determine the success or failure of the Multipurpose Panel concept are contrast ratio, color, brightness and uniformity.

There are also a number of constraints placed on the display devices by the anticipated Space Shuttle application. These include reliability, life, ruggedness, and safety which, as expected, impose somewhat severe conditions on hardware. The normal operating environment will be normal room temperature, atmospheric pressure and ambient lighting conditions.

In the search for alphanumeric devices to fulfill the program requirements, an exhaustive study of current display technology was conducted. The significant results of this survey will be presented here and recommendations for the most practical device or devices for this application will be discussed. Some important trends in display developments with respect to this program will also be shown.

4.1 CURRENT ALPHANUMERIC DISPLAY TECHNOLOGY

4.1.1 Light Emitting Diodes

LED's are the most widely used displays today because of their long life, reliability, ruggedness, and compatibility with integrated circuits. The high volume of LED's for the calculator and display markets, and competition from other display devices has resulted in rapid technological development, low cost, and improved manufacturing techniques. There are now many standard devices available to meet almost any small scale display application.

There are several 5 X 7 LED matrix arrays available which can be used to display alphanumeric information on the Multipurpose Panel and offer several advantages over other available devices. Their reliability and ruggedness are in line with the requirements of space flight. They are also safe for space applications since they do not contain harmful materials and are not subject to catastrophic failure. Finally, this application calls for small display sizes, an area where LED's are the most developed and competitive, since the major cost element of LED devices is the material cost which is directly related to display size.

LED's also offer several important advantages when we consider the electronic circuitry required to drive a large number of alphanumeric displays. They are the most compatible devices to interface with logic circuitry, and they can be multiplexed to great advantage. The scale of the Multipurpose

Display dictates multiplexing display elements in order to reduce the bulk of the decoding and driver electronics. LED's are particularly well suited for multiplexing because of their fast response time and because they operate more efficiently at the high drive currents that are required. When multiplexing or strobing N display elements, each element is excited for $1/N$ th of the total time period, but must emit N times the required average light intensity.

There are also several disadvantages to using LED's in the Multipurpose Panel. The small character sizes present a problem. The smallest commercially available alphanumeric character is .27 inch high. But high density LED arrays have been developed for special applications, so the development of a 1/8 inch high character is within the realm of possibility. Hewlett Packard is presently developing a .15 inch 5 X 7 matrix array for the commercial market which is scheduled to be available before the fabrication phase of the Multipurpose Panel Program. If these devices do not materialize, the development cost of such a device could be incurred.

Another disadvantage of LED's is the limited colors available. Only red LED alphanumeric devices are presently available, although other LED devices are available in green and yellow. Red panel nomenclature may be displeasing to the eye and fatiguing to the panel operator because of poor eye response to the color red. Green and yellow LED alphanumeric displays, which are near the peak eye response area of the visual spectrum, can be developed, but at the cost of reduced light output efficiency. The impact on driver circuitry is somewhat minimized because of more efficient eye response.

Finally, power consumption poses a significant problem in using a large number of LED devices. The recommended average forward current to operate one element of an LED array is approximately 5 ma. If we consider the statistical average of a third of the elements of each array excited and multiply this by 100 arrays, which does not constitute an overly large panel area, we can conclude that by specification, up to 6 amps of current would be required to drive the Multipurpose Panel shown in Figure 1.

A laboratory evaluation of the light output of a 4 X 7 diode array was performed to better estimate the power requirements for this program. The test consisted of a subjective evaluation by a number of technical people of the visual quality of a group of 5 arrays. The test was conducted under normal room ambient lighting level, and the brightness of the arrays was varied by maintaining a 5 ma current through each addressed element and varying the duty cycle of the diode excitation. It was unanimously agreed that adequate brightness levels could be obtained at duty cycles below 50% and that as a panel nomenclature display, the LED array would be more pleasing at a reduced lighting level. If we also consider the improved efficiency of LED devices when operated at higher current levels, we can conclude that 100 5 X 7 alphanumeric display configurations under consideration will require as low as 2 amps for a good visual display.

4.1.2 Plasma Displays

Plasma display panels produce lighted alphanumeric characters by the high voltage ionization of gas in the selected cells of a large array of such cells. The development

of plasma panels was motivated by the need for displays with a capacity for a number of characters fitting somewhere between single character readouts and large scale CRT displays. These devices are capable of displaying large numbers of small alphanumeric characters via a series of 5 X 7 matrices, and as such deserve serious consideration for use in a Multipurpose Panel. The most serious obstacle to this application is their limited flexibility since control panel nomenclature is usually distributed over the viewing area in a somewhat random manner, and plasma displays generally have concentrated display areas.

4.1.2.1 DC Plasma Displays

DC Plasma Displays can be best represented by the Burrough's Self Scan System. Standard displays include .2 inch high characters in lines of 32 and 80 characters, and .28 inch high characters in a line of 16 characters or a block of 256 characters. Other configurations can be produced, but are relatively expensive because of the associated development costs.

The Self Scan System includes both an alphanumeric display and the display decoding and driving circuitry. The panels require simply a 6 bit data input and a clock signal, and it interfaces directly with standard IC digital logic level signals, thereby eliminating the need for directly driving high voltage displays. The display is neon orange in color, and it is uniform. Good brightness can be obtained, and the brightness can be adjusted by varying the current to the drivers. Considered as a complete system, power consumption and cost are relatively low. Accurate lifetime estimates are not available, but based on past gas discharge display performance, DC

plasma displays have a potential for long life.

There are some serious drawbacks to using DC plasma panels in space applications. These devices do contain small amounts of mercury to extend life, and this poses a serious threat to crew safety because of their confined station. Secondly, because of the construction of these devices they may not be rugged enough to meet spacecraft requirements without special handling. Finally, the limited flexibility of the display because of the transfer of charge from cell to cell would prevent the DC plasma display from meeting the total needs of a Multipurpose Panel.

4.1.2.2 AC Plasma Display

The AC plasma displays also emit light from the ionization of gas in an array of cells. But unlike the DC plasma panels where a priming charge is shifted from cell to cell, the AC plasma panel operates by creating an initial discharge in a particular cell, and then sustaining that discharge by continually reversing the voltage applied between the cell electrodes.

The principal advantages of this scheme over DC plasma displays are increased flexibility in locating cells since each cell is excited independently, inherent memory, since information is sustained in the display until it is erased, and the absence of mercury. The major drawback of this display is the degree of difficulty involved in addressing the display. The inherent problems of addressing each cell individually, and interfacing with high voltage signals lead to high power consumption and an expensive system overall.

The Owens-Illinois Digivue system is presently the most developed AC plasma display available in line with the requirements of the Multipurpose Panel. This system is capable of displaying alphanumeric characters in a 5 X 7 matrix format as small as 1/8 inch high. The display is neon orange in color and exhibits a high brightness level, although brightness variation is somewhat limited since it is controlled by adjusting the sustaining voltage frequency. As in the case of the DC plasma display, life expectancy is good. The Digivue System has been developed for data terminal applications, and is designed to display multiline blocks of data. As a result, the use of an AC plasma panel in the Multipurpose Panel would involve a further development of the display.

4.1.3 Other Display Devices

In this section we will treat the other display devices available, which while they do not appear to offer practical solutions to the Multipurpose Panel concept, are included here for a complete view of present display technology.

4.1.3.1 Flat Panel CRT

The Digisplay System, developed by Northrop, is a flat panel CRT system intended for use in small data terminal applications similar to the Plasma panels. The only significant advantage of this system over plasma systems is the pleasing colors that can be obtained from CRT phosphors. On the negative side, the flat panel CRT is a relatively expensive system and lacks the flexibility needed for a Multipurpose Display, and more importantly, the flat panel CRT has stirred little interest in its most promising applications and would be a

risky alternative to pursue in the development of the Multipurpose Panel.

4.1.3.2 Incandescent Displays

There are a number of small incandescent displays available today. They operate by projecting incandescent light sources to a small front panel display via fiber optics or light pipes. These displays offer a wide range of colors, high brightness and excellent contrast. Unfortunately, these devices are practical only for small scale displays because of their price, and the rear panel volume consumed by these devices prohibit their use in the Multipurpose Panel.

4.1.3.3 Liquid Crystal

Recent interest in liquid crystal devices has been overwhelming, so the subject demands at least a cursory mention in this report. To date, there is no evidence of the potential for developing a small liquid crystal alphanumeric device. The close spacing of electrodes and the small surface area for light reflection or transmission make such a device impractical at present. Even if these problems could be overcome, liquid crystals are inherently slow devices in changing state and can not be multiplexed to any effective degree, and would therefore require a considerable amount of driving electronics.

4.2 FUTURE DEVELOPMENTS

The electronic display industry is still in the growth stage. The sudden popularity of hand calculators and

other consumer products has been an impetus to the development of display devices. The increasing emphasis on data terminals and the microminiaturization of electronics are providing incentive for the improvement of display technology. Among the many research projects in progress, there are several ideas which may prove beneficial to the Multipurpose Panel.

4.2.1 Improved Plasma Displays

At the present time, there are a number of seemingly unrelated projects underway in this area. National Electronics is marketing an AC plasma display, Plasmac, which is custom made to a buyers specifications by a process of silk screening electrodes. Plasmac is currently designed to meet large size display requirements, but National is now investigating the possibility of achieving high resolution from its process. Other companies are also experimenting with improving the drive requirements of AC plasma displays and depositing the drive electronics on the display package to reduce volume. If interest continues in these areas, the end result may be an extremely flexible display system with good visual characteristics at low cost.

4.2.2 Electroluminescent Displays

Electroluminescent displays have been disappointing in the past. Their potential advantages have been almost completely negated by usable life and reliability problems. Research for better materials and processes continues. In addition, efforts to combine microelectronics and electroluminescent materials on the same substrate are in progress. While the future of these displays does not appear optimistic, they should

not be overlooked in future applications.

4.2.3 Ferroelectric Ceramic Displays

PZLT ceramic, an electro-optic material which can be operated as a light valve when controlled by an electric field, is presently being developed for use in many displays and optical devices. This material offers many advantages including high contrast ratio, fast switching speeds, good resolution, long life, and inherent memory. The major problem confronting development efforts is the high voltage and elaborate configurations required to activate this material.

Progress is being made in this area and in fact Sandia Laboratories, a leader in this technology, is approaching the point of making a numeric display commercially available. If the potential of this material is realized, it would provide an ideal display for the Multipurpose Panel. It could be used to control light transmission from a back panel light source, and it would provide high resolution, good visual quality and flexibility.

4.3 CONCLUSIONS AND RECOMMENDATIONS

To summarize, today there are a number of alphanumeric devices available which meet or can be modified to meet the requirements of the Multipurpose Panel. However, because of space, power and drive requirements, no one device would be adequate for use in a moderately sized control panel. Therefore, we recommend that a combination of LED and Plasma devices be used in any Multipurpose Panel application in the near future. The LED's would provide the flexibility required for

small spaces, and the Plasma display would be used in areas where large blocks of alphanumeric information are required. Uniform color can be obtained by the proper selection of optical filters. The plasma devices emit light over a wide range of the visual spectrum, making it possible to match light output from these devices to the narrow range of light output emitted by LED's.

Since the primary purpose of this program is to demonstrate the feasibility of a Multipurpose Panel, and since the scale of the demonstration model and limited budget to develop the model dictate it, LED's will be used to display panel nomenclature. Red LED devices will be employed because of their availability. We propose that LED's will provide the good visual display necessary to demonstrate the feasibility of the Multipurpose Panel, and that the use of LED's for this development program will result in savings in cost and time.

Finally, in light of the development programs presently in progress in the display industry, the concept of a Multipurpose Panel is very practical. While the main emphasis in displays is directed toward the mass market, the spinoffs from technological innovation are creating many alternatives and opportunities for the refinement of a programmable control and display panel toward the quality of present day dedicated panels.