

General Disclaimer

One or more of the Following Statements may affect this Document

- This document has been reproduced from the best copy furnished by the organizational source. It is being released in the interest of making available as much information as possible.
- This document may contain data, which exceeds the sheet parameters. It was furnished in this condition by the organizational source and is the best copy available.
- This document may contain tone-on-tone or color graphs, charts and/or pictures, which have been reproduced in black and white.
- This document is paginated as submitted by the original source.
- Portions of this document are not fully legible due to the historical nature of some of the material. However, it is the best reproduction available from the original submission.

MCDONNELL DOUGLAS TECHNICAL SERVICES COMPANY, INC.
HOUSTON ASTRONAUTICS DIVISION

ADVANCED CREW PROCEDURES DEVELOPMENT TECHNIQUES
DESIGN NOTE NO. 12

PROCEDURES AND PERFORMANCE PROGRAM DESCRIPTION

26 SEPTEMBER 1975

This Design Note is submitted to NASA in Partial Fulfillment
of Contract NAS 9-14354

(NASA-CR-144517) ADVANCED CREW PROCEDURES
DEVELOPMENT TECHNIQUES: PROCEDURES AND
PERFORMANCE PROGRAM DESCRIPTION

N76-10734

(McDonnell-Douglas Technical Services)
110 p HC \$5.25

Unclas

CSCL 05H G3/54 39634

PREPARED BY:

James D. Arbet
D. Arbet
Requirements and Operations
Group Leader
Advanced Crew Procedures
Development Techniques
483-2541

PREPARED BY:

A. A. Mangiaracina
A. A. Mangiaracina
Software Group Leader
Advanced Crew Procedures
Development Techniques
483-2541

APPROVED BY:

Robert L. Benbow
R. L. Benbow
Principal Investigator
Advanced Crew Procedures
Development Techniques
483-4271

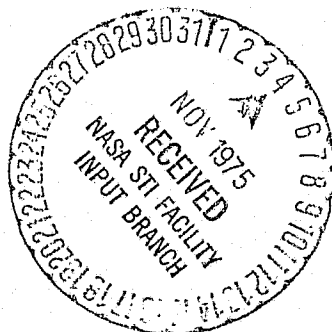

1.0 SUMMARY

This design note describes the Procedures and Performance Program (PPP) (formerly referred to as the Procedures Generation Program (PGP)) as designed to operate in conjunction with the Shuttle Procedures Simulator (SPS). Included is a description of the PPP user interface, the SPS/PPP interface, and the PPP applications software. This document supercedes Crew Procedures Development Techniques Design Note No. 7 (ACPDT DN: No. 7) dated 20 September 1974.

2.0 INTRODUCTION

The PPP is an automated procedures recording and crew/vehicle performance monitoring system. Initial development and demonstration of the feasibility of this system was performed under NASA contract NAS 9-13660. The purpose of this follow-on contract, NAS 9-14354, is to expand the initial system development by incorporation of the necessary changes to stay current with the SPS development and by incorporation of additional user interface terminals: (1) the CDC 243 - Graphics Terminal - an advanced interactive graphics terminal, and (2) the Hazeltine 4000 G Terminal currently in use with the Generalized Document Processor (GDP).

The ACPDT Design Note No. 7, dated 20 September 1974, Reference 1, presented the initial program description. Since publication of that design note major program modifications and additional capabilities have been incorporated in the PPP. This design note presents the complete program description of the current PPP capability.

3.0 DISCUSSION

The heart of the PPP system is a digital computer program which translates SPS data inputs into crew procedures. These procedures may be compared with a stored reference, thus providing a difference procedures capability. The program also monitors and records selected crew and vehicle performance parameters. These performance parameters may be compared to a set of established criterion, thus providing a performance evaluation capability. These procedures and performance data are available for CRT display according to user specified format in real-time, post-run, and on hardcopy output. The data may be transferred to the Generalized Document Processor (GDP) for formal documentation and distribution.

The current PPP is designed to utilize either the CDC 211 terminal or the CDC 243 terminal as the user interface device for control and monitoring. The CDC 211 terminal provides a display of alphanumeric data, while the CDC 243 terminal provides graphical data displays. Because of core limitations of the SPS/PPP system, the user has access to only one terminal at a time.

Figure 3.0-1 provides a pictorial view of the interface between the GDP, PPP, and the SPS computer complex. This figure shows the system in its planned form. The shaded items are not yet implemented.

PPP/SPS/GDP INTERFACE

FIGURE 3.0-1

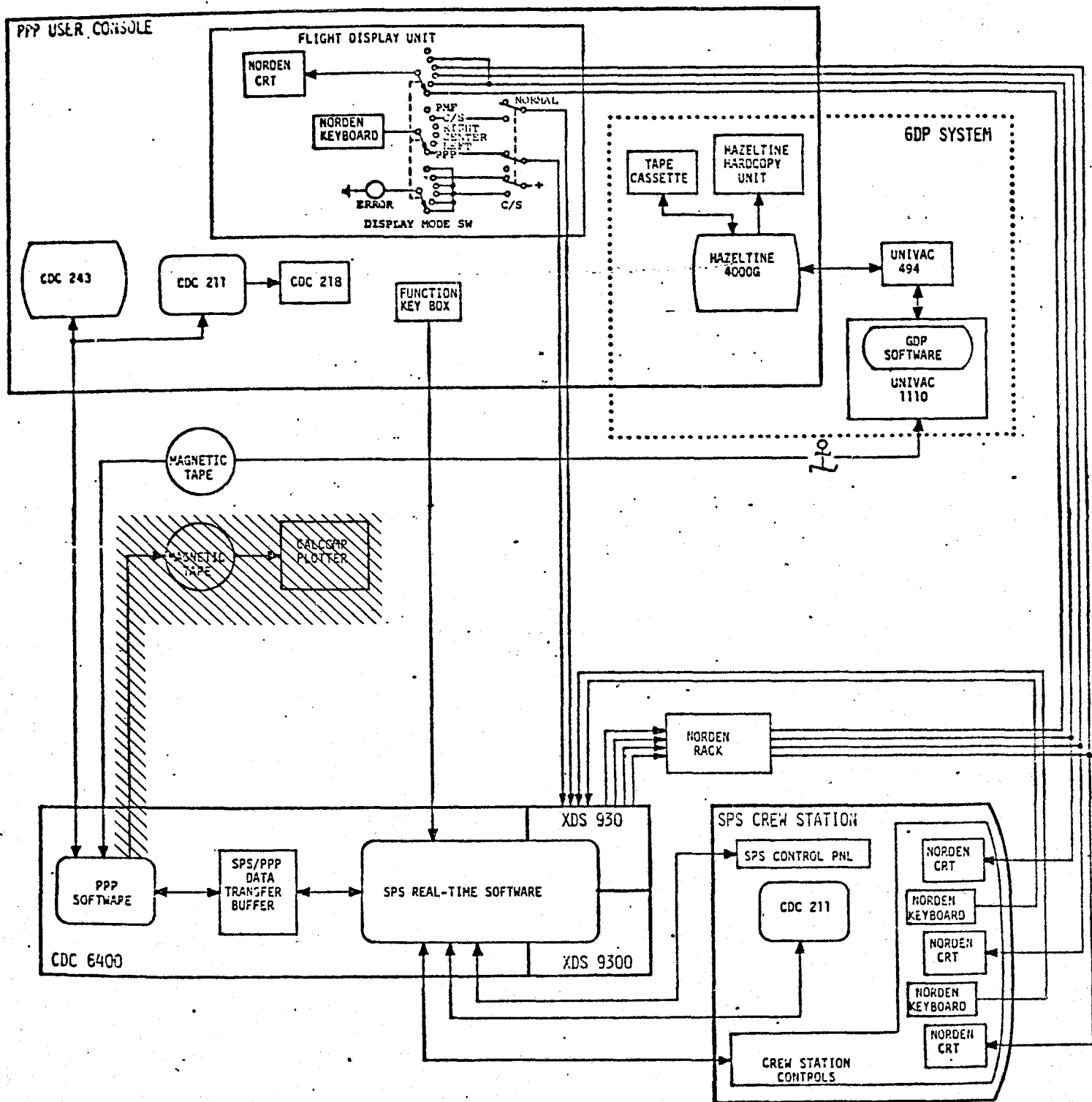

The PPP capabilities provide real-time CRT outputs and post-run hardcopy outputs of various data associated with SPS operations. These outputs provide valuable information to simulation, training, and procedures development personnel. The following highlights information available and possible usage for each group.

Using the PPP, simulation personnel can verify crew station control inputs and corresponding hardware and software output responses. Alphanumeric procedures data generated by the PPP, provide a record of crew station input/output discrete interaction. These data are time tagged and therefore provide an indication of the reaction time between input and output. Alphanumeric and graphical performance data generated by the PPP, provide a record of the simulated vehicle dynamic characteristics. These data, also time tagged, when combined with the procedures data, represent vital documentation for SPS hardware and software verification. The recording and subsequent hardcopy output of PPP generated data also provide maintenance personnel firm documentation of simulator problems. Problems during simulator operations can be easily duplicated without guessing what prior operations occurred. Finally the PPP recording of simulator operations provides documentation on SPS utilization.

Training personnel can utilize the PPP in many different ways. Prior to each training exercise, the instructor can verify the proper initial SPS crew station configuration. During an exercise, crew operations and vehicle responses are monitored and, if desired, may be compared against an established reference. The reference procedures data provide a check on how closely the crew is following the established operating procedures and the performance evaluation data provide an indication of

whether the run is within perestablished criterion for various vehicle parameters. PPP data are available which indicate the crews responsiveness to vehicle malfunction indications. This realtime data give the training personnel the ability to closely control training sessions, thus allowing early termination of sessions which do not appear constructive. The post-run output provides documentation for crew debriefings and subsequent reviews of a training exercise. Here again, recording simulator operation provides documentation on SPS utilization and also of crew training activities.

Procedures development personnel can utilize the PPP for procedural techniques development and procedures development. Using an abbreviated timeline the procedures developer operates the SPS and then uses the performance data to check and verify the response to new techniques. The PPP recorded procedures data then provide the initial procedures documentation. Subsequent runs may be made to refine the newly developed procedures with the updated procedures immediately documented. Magnetic tape output of the procedures data also provide for direct transfer to the Generalized Documentation Processor (GDP). The GDP then provides the capability to finalize the procedures for FDF documentation. Another item worth noting is the consistency of FDF document nomenclature; since all nomenclature is generated from one source, the PPP data base.

3.1 PPP User Interface

The user interface for control of PPP operations and for monitoring onboard systems is the PPP user console. The console contains hardware to input PPP commands, display PPP alphanumeric and graphical data, monitor SPS

crew station CRT displays, and transfer procedures data between the PPP and GDP. The functional connection of the user console hardware is shown in Figure 3.0-1. The following provides a list of the console hardware within a description of the functions performed by each.

1. CDC 211 Display and Entry Station

One of the user input and display stations. The CDC 211 keyboard provides input capability to direct PPP operations and access PPP data. The CRT provides an alphanumeric display of procedures and performance data on the established PPP formats. The contents of the CRT can be printed out on the CDC 218 when the PRINT key on the CDC 211 keyboard is depressed.

2. CDC 243 Graphics Terminal

Another user input and display station. This station also provides input capabilities to direct PPP operations and access data. Inputs may be made either from the CDC 243 keyboard or by a light pen directed at the CDC 243 CRT. The CRT provides graphical displays of SPS performance data. Because of core limitations of the SPS/PPP system, the user has access to either the CDC 211 or CDC 243 input and display station, but not both at the same time.

3. PPP Function Keys

The PPP function keys are five momentary, press to activate, switches. The keys are available to perform various PPP functions. One function, presently defined, inserts cues into the PPP data stream to facilitate returning to a specific data point at a later time. Another freezes the CDC 211 CRT display to allow command inputs from the PPP input stations.

4. Hazeltine 4000G Terminal, Keyboards & Tape Unit

This terminal is used to monitor PPP developed procedures and to transfer procedures data between the PPP and GDP. PPP procedures data is output by the PPP to the Hazeltine CRT on a page by page basis. After each page is displayed on the CRT, the PPP user may transfer the CRT page to the Generalized Documentation Processor (GDP).

GDP text editing capabilities allow the procedures developer to finalize the procedures on the GDP system. Then the Hazeltine CRT may display either GDP data and direct data storage to either system. Mechanically switching between PPP and GDP does not change the data displayed on the Hazeltine CRT.

5. Norden CRT, Keyboard, Keyboard Monitors and Selector Switch

The Norden CRT's on the PPP user console allow the user to monitor each of the SPS simulated onboard CRT's. Also the selector switch provides the capability to activate the console Norden keyboard and reconfigure one CRT to PPP user control. This allows the user to call up any desired SPS flight display at the PPP user console.

3.1.1 PPP User Commands And Displays

The PPP user must input various commands during PPP operations to obtain the desired PPP results. Prior to processing SPS run data the user must

input required data for PPP initialization. During the run, various commands are input to allow the user to monitor the desired data display. After completion of the run, the user is required to input more commands to obtain the desired hardcopy data outputs and to either initialize for another run or terminate PPP operations. The following discussion presents the PPP user commands and a description of the available displays. Reference 2 provides more information on user operations and displays.

The PPP displays are grouped in three levels, each level corresponding to a command step taken in the callup sequence. The structure, called a display tree, is shown on Figure 3.1.1-1. and 3.1.1-2 (i.e., the PPP Alphanumeric Display Tree and PPP Graphical Display Tree).

Figure 3.1.1-3 presents the two alphanumeric display pages which list the valid PPP user commands. When the user inputs COMMAND, the first page of the user commands is displayed on the CDC 211 CRT. The ↑ (up arrow) provides the capability to display the other page of the format.

Figure 3.1.1-1 PPP Alphanumeric Display Tree

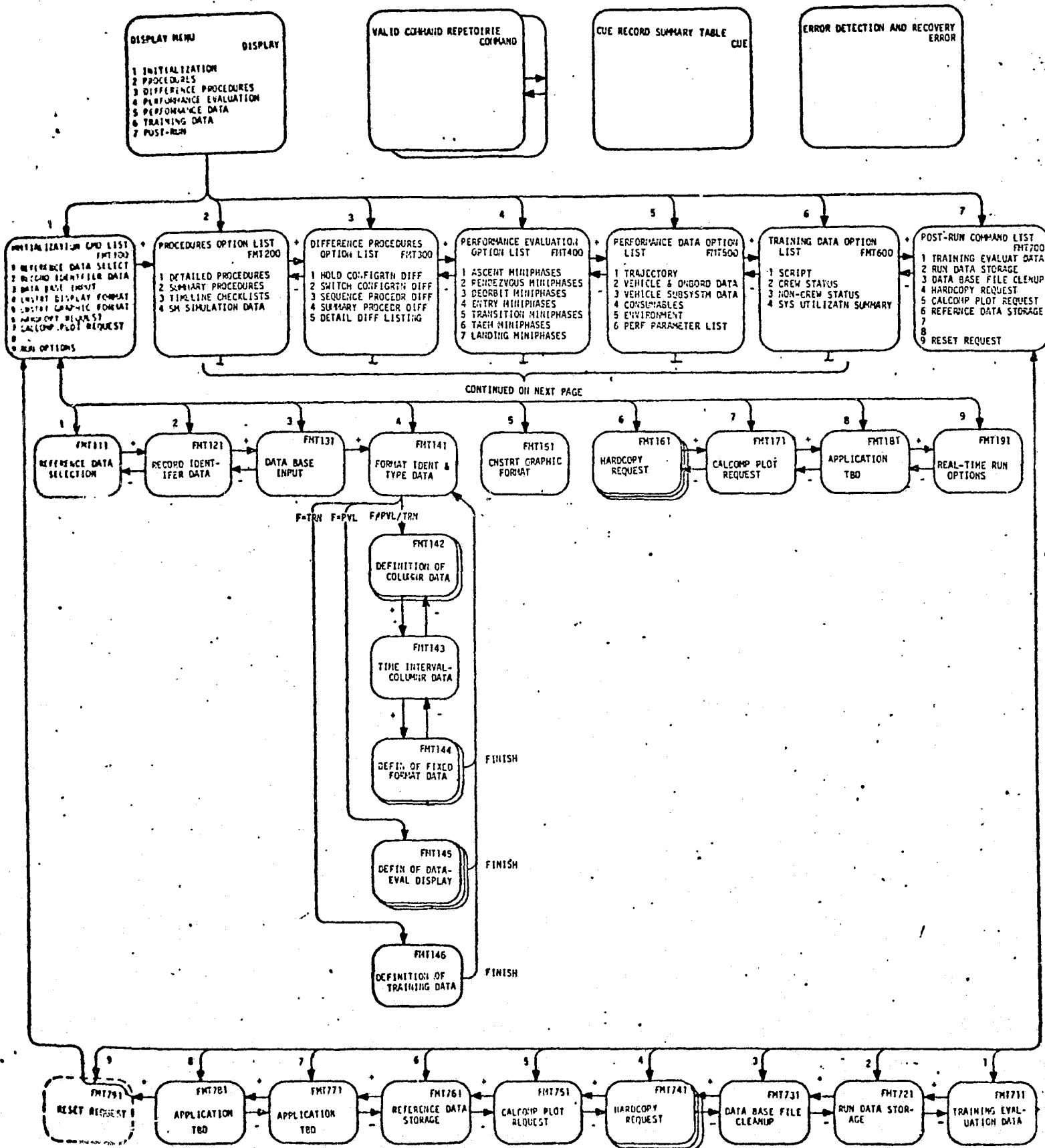
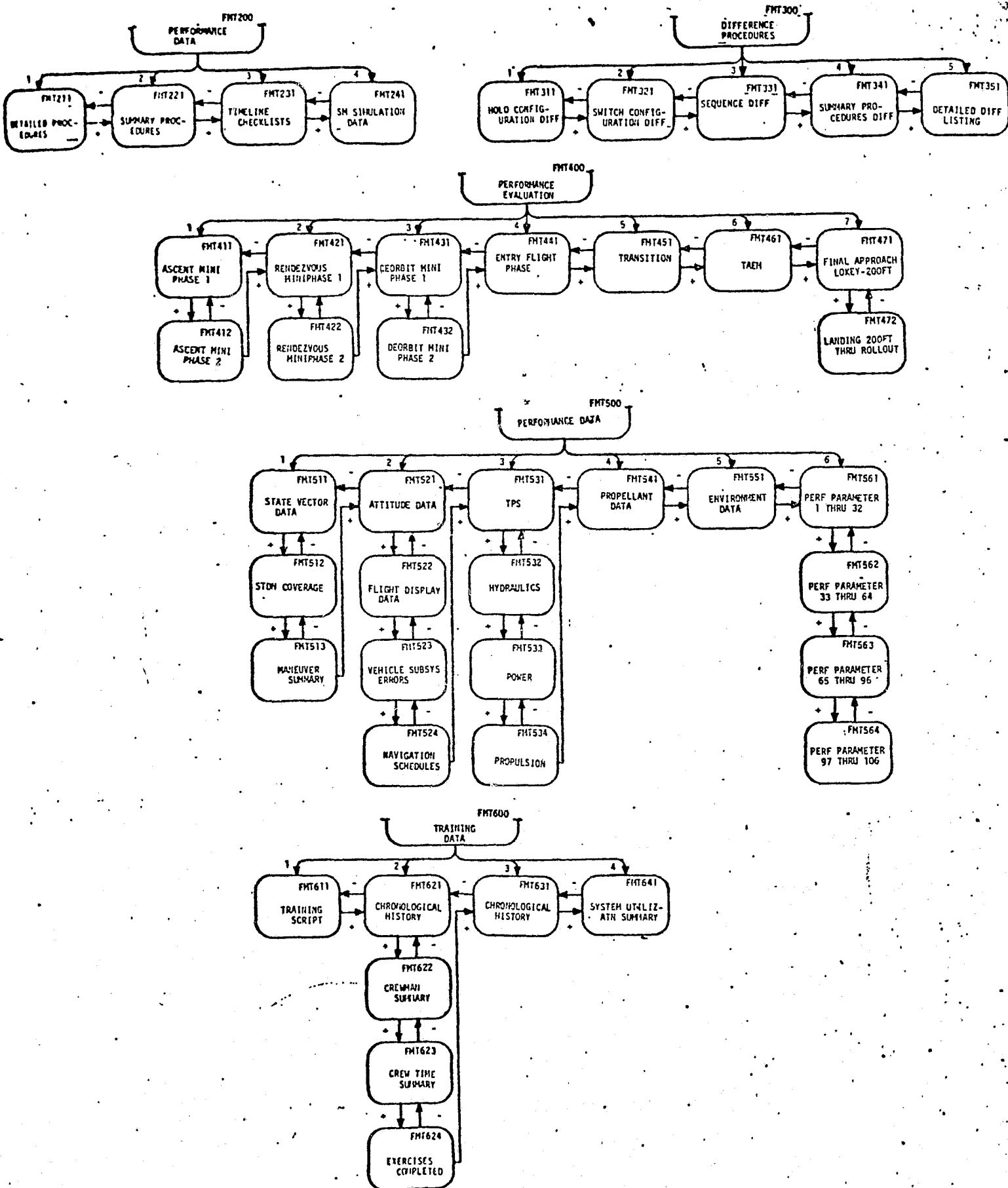

Figure 3.1.1-1 PPP Alphanumeric Display Tree (Cont.)



SPACE SHUTTLE PROGRAM OFFICE
SPACE SHUTTLE ENGINEERING AND OPERATIONS SUPPORT
NAS 9-13970
TASK ORDER NO. C0403

TASK TITLE: FCS INTEGRATION SUPPORT

DATE: NOVEMBER 1, 1975

MDC TASK MANAGER: W. H. Geissler

JSC TASK MONITOR: K. J. Cox

APPROVED:

J. F. Hanaway
Manager, Avionics Systems Engineering Support
NASA Johnson Space Center

APPROVED:

Owen G. Morris
Systems Integration Manager
NASA Johnson Space Center

APPROVED:

A. Cohen
Manager, Orbiter Project
NASA Johnson Space Center

APPROVED:

R. M. Machell
SSEOS Technical Manager
NASA Johnson Space Center

APPROVED:

R. A. Law
Contracting Officer
NASA Johnson Space Center

ACCEPTED:

C. Jacobson
Program Manager
McDonnell Douglas

Figure 3.1.1-2 PPP Graphical Display Tree.

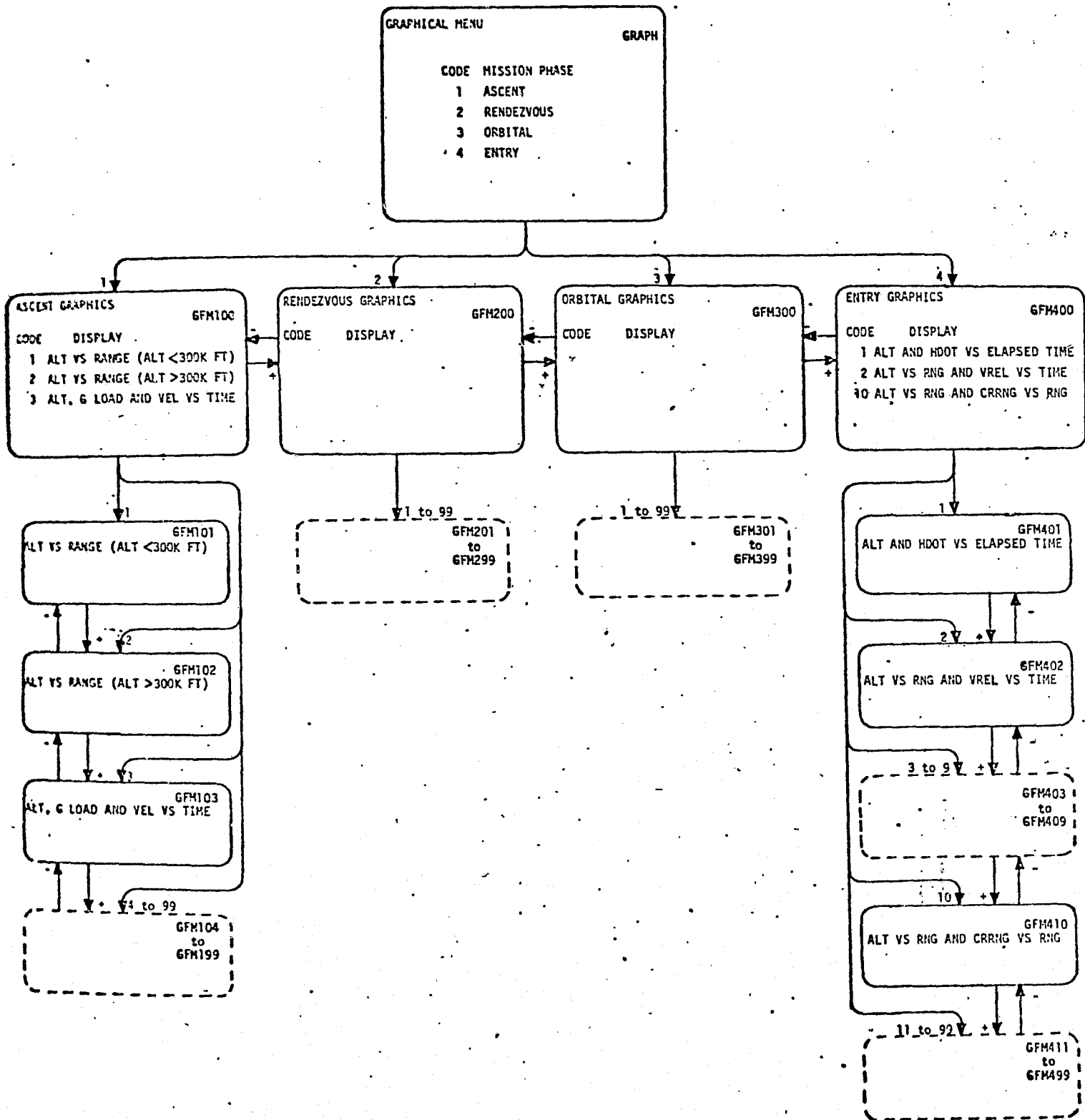

Figure 3.1.1-3 Valid Command Repertoire

VALID COMMAND REPETOIRE	ACTUAL
RO0DE000N001C000P000I000	BATCH 08/28/75 COMMAND
COMMAND	PRESENTS VALID COMMAND REPETOIRE (211)
CUE	PRESENTS CUE RECORD SUMMARY TABLE (211)
DISPLAY	PRESENTS DISPLAY MENU AND INITIATES FORMAT CALLING SEQUENCE (211)
GRAPH	PRESENTS GRAPHIC MENU AND INITIATES FORMAT CALLING SEQUENCE (243)
N	PRESENTS N-TH FORMAT AT NEXT LEVEL
DISPLAY=L,	PRESENTS SPECIFIC FCRMAT (211)
M,N	L= LEVEL 1, M= LEVEL 2, N= LEVEL 3
GRAPH=L,	PRESENTS SPECIFIC FCRMAT (243)
M,N	L= LEVEL 1, M,N= LEVEL 2
+-----	ADVANCE ONE DISPLAY FORMAT
------	MOVE BACK ONE DISPLAY FORMAT
↑-----	ADVANCE ONE DISPLAY PAGE
↓-----	MOVE BACK ONE DISPLAY PAGE
^-----	ADVANCE ONE DISPLAY LINE
∨-----	MOVE BACK ONE DISPLAY LINE

VALID COMMAND REPETOIRE	ACTUAL
RO0DE000N001C000P000I000	BATCH 08/28/75 COMMAND
*	SELECT NEXT DISPLAY FROM ROTATION ARRAY
CLEAR	CLEAR DISPLAY ROTATION ARRAY
REPEAT=L	CONSTRUCT CURRENT DISPLAY AT INPUT TIME
M,N	L=TIME REF CODE, OR MAJOR EVENT M=TIME (HHH/MM/SS), OR DELTA TIME (MM/SS) N=PERFORMANCE DATA STEP INTERVAL
CONTINUE	RETURN DISPLAY TIME TO CURRENT TIME
/	CHANGE DATA SOURCE BETWEEN ACTUAL DATA AND REFERENCE DATA
COPY=L	COPY DISPLAY TO: L=LP PRINTER L=MT MAGNETIC TAPE L=CP CALCOMP PLOTTER
COMPARE	REQUEST COMPARISON OF CREW STATION
SWITCH	CHANGE CARD/TERMINAL INPUT SOURCE
RUNRT	INITIATE REAL-TIME SPS XFER
ENDRT	END REAL-TIME SPS XFER-BEGIN NON R/T
TERMINATE	TERMINATE PPP EXECUTION

Figure 3.1.1-4 is displayed when the user inputs CUE, the second command on the user command list. This format provides a list of the cues input into the data stream during the simulation run. Using the sequence number or the GET time the user can return to the specific data desired. This format would be used after a run or while the simulation is in hold.

Figure 3.1.1-4
Cue Record Summary Table

CUE RECORD SUMMARY TABLE				ACTUAL	
R000E000N001C000P000I000 BATCH 08/28/75				CUE	
SN	GET	SN	GET	SN	
1	XXX/XX/XX	11	XXX/XX/XX	21	XXX/XX/XX
2	XXX/XX/XX	12	XXX/XX/XX	22	XXX/XX/XX
3	XXX/XX/XX	13	XXX/XX/XX	23	XXX/XX/XX
4	XXX/XX/XX	14	XXX/XX/XX	24	XXX/XX/XX
5	XXX/XX/XX	15	XXX/XX/XX	25	XXX/XX/XX
6	XXX/XX/XX	16	XXX/XX/XX	26	XXX/XX/XX
7	XXX/XX/XX	17	XXX/XX/XX	27	XXX/XX/XX
8	XXX/XX/XX	18	XXX/XX/XX	28	XXX/XX/XX
9	XXX/XX/XX	19	XXX/XX/XX	29	XXX/XX/XX
10	XXX/XX/XX	20	XXX/XX/XX	30	XXX/XX/XX

USAGE - TO RETURN TO A SPECIFIED CUE TIME,
PLACE SPS IN HOLD AND DO ONE OF THE FOLLOWING
(1) SELECT AND KEY IN SN- THIS DISPLAY MUST BE UP
(2) USE REPEAT=L,M COMMAND

GET 0/00

Figure 3.1.1-5 is displayed when the user inputs an erroneous command. The format informs the user what the command input was, describes the error and instructs the user how to recover.

Figure 3.1.1-5 Error Detection and Recovery

ERROR DESCRIPTION AND RECOVERY	ACTUAL
R000E000N001C000P000I000 BATCH 08/28/75	ERROR
USER COMMAND WAS	
DSPLY	
DESCRIPTION OF ERROR MESSAGE	
COMMAND NOT IN COMMAND REPETOIRE	
DESCRIPTION OF HOW TO RECOVER	
CHOOSE ONE OF THE FOLLOWING	
(1) REVIEW VALID USER COMMANDS-KEY IN- COMMAND	
(2) RETURN TO PREVIOUS DISPLAY-KEY IN- *	
(3) CONTINUE WITH USER SUPPLIED COMMAND	
GET	0/00

Figure 3.1.1-6 is displayed when DISPLAY, the third command on the user command list, is input. The format is the top level display in the display tree logic and presents a menu of PPP second level categories. An input of a number N(N=1 through 7 corresponding to second level category numbers), allows the user to advance the display to second level formats. Each second level displays presents a menu of associated third level categories. Another N(N corresponding to third level category numbers) input advances the display to the third level category. Formats may also be displayed by direct input of the format number using the DISPLAY=L,M,N command.

Figure 3.1.1-6 PPP Alphanumeric Display Menu

DISPLAY MENU		ACTUAL
R000E000N001C000P000I000 BATCH 08/28/75		DISPLAY
1	INITIALIZATION	
2	PROCEDURES	
3	DIFFERENCE PROCEDURES	
4	PERFORMANCE EVALUATION	
5	PERFORMANCE DATA	
6	TRAINING DATA	
7	POST-RUN	

Following is a sample of each of the categories as listed on the PPP display menu.

Initialization

The initialization of the PPP requires a basic set of data input prior to starting the simulation run, such as specifying the reference data for difference procedures comparisons. In addition, optional inputs are available such as construction of display formats. Figure 3.1.1-7, the PPP INITIALIZATION COMMAND LIST, presents the menu of the required and optional categories. All inputs are made in accordance with the tutorial displays which are initiated by selecting the appropriate code number.

Figure 3.1.1-7 PPP Initialization Command List

INITIALIZATION COMMAND LIST			ACTUAL
			BATCH 08/28/75 FMT100
CODE	OPERATION	CATEGORY	STATUS
1	REFERENCE DATA SELECTION	REQUIRED	
2	RECORD IDENTIFIER DATA	REQUIRED	
3	DATA BASE INPUT	OPTIONAL	
4	CONSTRUCT DISPLAY FORMATS	OPTIONAL	
5	CONSTRUCT GRAPHIC FORMATS	OPTIONAL	
6	HARDCOPY REQUEST	OPTIONAL	
7	CALCOMP PLOT REQUEST	OPTIONAL	
8	HISTORICAL LOG REQUEST	OPTIONAL	
9	REAL-TIME RUN OPTIONS	REQ/OPT	

Procedures

When Procedures formats are displayed with the SPS in RUN or HOLD, the option to display actual or reference data exists. The command "/" transfers the data display from one source to the other. Returning to the original source requires another "/" command. The source is noted by ACTUAL or REFERENCE in the format header. Actual data is automatically selected as the display source during each PPP initialization or SPS reset. Format 200, shown in Figure 3.1.1-1, is the menu of Procedures level 3 categories. Figure 3.1.1-8 presents the format for detailed procedures. This is one of four available procedures formats.

Figure 3.1.1-8 Detailed Procedures Format

DETAILED PROCEDURES TIMELINE				ACTUAL
RSM2E000M0010000P000T000	RUN	09/23/75	FMT211	
GET LT	OPERATIONS		PNL	
INV 2	POWER R-OUT			03
INV 2	POWER C-IN			03
INV 2	POWER C-OUT			03
INV 3	POWER A-IN			03
INV 3	POWER A-OUT			03
INV 3	POWER B-IN			03
INV 3	POWER B-OUT			03
INV 3	POWER C-IN			03
INV 3	POWER C-OUT			03
AC1	BUS A-IN			03
AC1	BUS A-OUT			03
AC1	BUS B-IN			03
AC1	BUS B-OUT			03
AC1	BUS C-IN			03
AC1	BUS C-OUT			03
AC2	BUS A-IN			03

Difference Procedures

During a run, difference comparisons are performed regardless of whether Difference Procedures formats are displayed. The user is notified of a detected difference by a flashing message (1 second rate-15 second duration) on the user command line. The display contains the appropriate command for selecting the proper difference format and the words "SWITCH or SEQUENCE DIFFERENCE DETECTED." Format 300, shown in Figure 3.1.1-1, presents the menu of the five available Difference Procedures formats.

The SEQUENCE DIFFERENCE, Figure 3.1.1-9, presents crew station operation and major mission event sequence differences between the current and reference run. The PPP data base contains the mission event related time when a sequence test starts and the switch groups and mission events to be considered in the test. The reference procedure provides the proper sequence for the selected switches and events. When a sequence is detected the user is notified by a flashing message on the user command line and the sequence difference data is stored. The format identifies the event related COMPARISON START time, the ACTUAL SEQUENCE, and REFERENCE SEQUENCE. The GET corresponding to the event comparison start time is included on the last line of the display.

Figure 3.1.1-9 Difference Procedures (SEQUENCE) Format

SEQUENCE DIFFERENCE				ACTUAL	
PSM2E000N0010000P000T000				RUN 09/23/75 FMT331	
COMPARISON START- .05 G				+ 0/00	
ACTUAL SEQUENCE	PML	REF SEQUENCE	PML		
H2O PUMP SEC-ON	L1	H2O PUMP SEC-ON	L1		
H2O PUMP SEC-OFF	L1	H2O PUMP SEC-OFF	L1		
H2O BYPASS SEC-MAN	L1	H2O BYPASS SEC-MAN	L1		
H2O BYPASS SEC-OFF	L1	H2O BYPASS SEC-OFF	L1		
NH3 RLR F CON A-SEC	L1	H2O BYPASS SEC-AUTO	L1		
NH3 RLR F CON A-PRI	L1	H2O BYPASS SEC-OFF	L1		
		NH3 RLR F CON A-SEC	L1		
		NH3 RLR F CON A-PRI	L1		
		NH3 RLR F CON A-OFF	L1		
GET 0/19/07					

Performance Evaluation

When the SPS is in RUN or HOLD, performance evaluation formats are displayable. These formats compare selected SPS performance parameters with the performance criteria located on the PPP performance evaluation format. Parameter excursions beyond the criterion values result in the display of the deviations. The formats cover various mission miniphases (i.e., Entry, Transition, etc.) and automatically cycle to the proper format when that miniphase is initiated. Format 400, shown in Figure 3.1.1-1, provides a menu of available formats. Figure 3.1.1-10 shows a typical display of the entry miniphase performance evaluation format. This display provides a column of the evaluation parameters and the associated criterion. Actual values may reflect one time occurrences such as the attitude at 0.05g or maximum values such as the max g-load experienced during the miniphase. When a performance parameter exceeds the established criterion the deviation is displayed in the last column.

Figure 3.1.1-10 Performance Evaluation Format

ENTRY FLIGHT PHASE		ACTUAL	
RSM2E000N001C000P000T100		RUN 09/23/75 FMT441	
GET		0/03/21	
		0.	
PARAMETER	CRITERION	ACTUAL	DEVIATIONS
ATT. AT .05G			
ALPHA	30. +/- 3.	29.	
BANK	0. +/- 3.	0.	
SIDESLIP	0. +/- 2.	0.	
MAX G-LOAD	< 2.	0.	
MAX QDOT	< 100.	73.	
MAX HEADING	0. +/- 20.	22.	49. 29.
MAX TEMP	< 2300.		
RANGE NMTLES	+300. +370.		
MAX HDOT	-700. +200.	-508.	-83.
MAX EL HNG M	0. +/- 1000.		
MAX BANK ANG	0. +/- 120.	-28.	1.

Performance Data

When the SPS is in RUN or HOLD, performance data formats are available for display. These formats present various parameters associated with vehicle and mission status. Format 500, shown in Figure 3.1.1-1, provides the menu of the available formats. Figure 3.1.1-11 shows a typical display of the performance data format. This particular display (FMT561) represents the first 32 parameters of the performance data file transferred from the SPS to the PPP.

Figure 3.1.1-11 Performance Data Format

PERFORMANCE PARAMETERS 1 THRU 32		ACTUAL
RSM2E000N0001003000000000		RUN 09/23/75 FMT561
0/02/27		
TIME 146.29	LOC. ZR ERR 0.	
CR RANGE -544732.	GLDRLP ERR 0.	
DN RANGE 16778196.	FLV DEFLECT 0.	
RANGE 4105.	R F DEFLECT 0.	
QDOT 41.	ALTITUDE 277247.	
HDOT -413.	BANK CMDDED 0.	
REL VEL 25163.	MACH NO 29.	
G LOAD 0.	A71 0.	
G X-AXIS 0.	EL1 0.	
G Z-AXIS 0.	A72 0.	
HDOT CMDDED -28.	EL2 0.	
ICORD 0	A73 0.	
BANK 0.16	EL3 0.	
ANG OF ATT 29.	THETADOT 0.	
LATITUDE 0.	PHIDOT 0.	
LONGITUDE 2.	PSIDOT 0.	

Training Data

When the SPS is in HOLD or when the PPP is in the BATCH mode, training data formats are accessible to the user. These formats present various data concerning crew and non-crew training, system utilization and PPP and SPS user console operations. Figure 3.1.1-12 shows format FMT600 containing the menu of available training data formats.

Figure 3.1.1-12 Training Data Menu

TRAINING DATA	ACTUAL
RSM2E000N001C0000000I000	BATCH 09/23/75 FMT600
CODE	OPERATION
1	SCRIPT
2	CREW STATUS
3	NON-CREW STATUS
4	SYSTEM UTILIZATION SUMMARY

Figure 3.1.1-13 shows an example of format FMT611, TRAINING SCRIPT data. Displayed here are all the operations, including erroneous inputs and associated error messages, made at the PPP users' console, all those SPS operator actions which are transferred to the PPP (e.g., 930-ON, COMPUTER HOLD, malfunction inputs, etc.), and the twenty-four words of SPS initial switch configuration data.

Figure 3.1.1-13. Training Script Format

TRAINING SCRIPT		ACTUAL
PSM2E000N001C000P000T000		BATCH 09/23/75 FMT611- 1
TIME	PPP OPERATIONS	SPS OPERATIONS
0/00/00	SWTCH	
0/00/00	1	
0/00/00	5	
0/00/00	ACCEPT	
0/00/00	2	
0/00/00	M=ENT	
0/00/00	P=SM2	
0/00/00	ACCEPT	
0/00/00	9	
0/00/00	1	
0/00/00	ACCEPT	
0/00/00	DISPLAY=2,1,1	
0/00/00	CLEAR	
0/00/00	RUN	
0/00/00		COMPUTER OPERATE

Figure 3.1.1-14 shows a typical display of format FMT621, the crew chronological history display. FMT621 lists each SPS crew training activity in chronological order with the most recent activity first. For each date the data shown includes: the participating crewman's name, the crewstation position he occupied during the run (pilot, mission specialist, etc.), the number and description of the exercise performed during a simulator run and the length of the run.

Figure 3.1.1-14 Typical Training Statistics Format

CHRONOLOGICAL HISTORY				ACTUAL
PSM2E000N001C000P00ST000 BATCH 09/23/75 FMT621-				1
DATE	CREWMFN	EXERCISE	DESCRIPTION	TIME
5/5/85	DAM	P	997 FUEL CELL FAILURE	0/20
4/05/81	ACS	C	998 OMS FAILURE	0/15
4/05/81	PLR	C	998 OMS FAILURE	0/33
8/23/79	DFG	L	785 MODE I, II ABORTS	0/55
8/23/79	HYT	L	503 EPS MALFUNCTIONS	1/14
2/03/79	DFA	L	789 ONCE AROUND ABORT	1/32
9/9/78	TCT	M	507 ECS MALFUNCTIONS	1/51
10/11/77	WCE	L	546 ECS SYSTEM MGMT	2/09
8/10/77	TCT	M	105 RENDEZVOUS	0/18
7/09/76	RFC	P	103 ORBITAL	0/37
5/05/76	TCT	C	997 FUEL CELL FAILURE	0/55
7/27/75	CMS	L	507 ECS MALFUNCTIONS	1/14
7/27/75	CMS	L	507 ECS MALFUNCTIONS	0/13
7/05/75	YTP	P	786 MODE III ABORTS	0/12
7/05/75	EDS	P	105 RENDEZVOUS	0/11
7/05/75	ARC	C	111 TERMINAL ARFA ENERGY	0/02

Post Run

The Post Run formats require a basic set of data input prior to a subsequent run or termination of operations. Also optional inputs are available. All Post Run formats present the inputs by means of tutorial display. Format 700, Figure 3.1.1-15, the PPP POST RUN COMMAND LIST, presents a menu of required and optional categories. The user selects the desired code for display and then inputs the specified data per the resulting tutorial display.

Figure 3.1.1-15 Post Run Tutorial Display

POST-RUN COMMAND LIST			ACTUAL
R000E000N001C000P000I000			BATCH 08/28/75 FMT700
CODE	OPERATION	CATEGORY	STATUS
1	TRAINING EVALUATION DATA	REQ/OPT	
2	RUN DATA STORAGE	REQUIRED	
3	DATA BASE FILE CLEANUP	OPTIONAL	
4	HARDCOPY REQUEST	OPTIONAL	
5	CALCOMP PLOT REQUEST	OPTIONAL	
6	MERGE RUN DATA	OPTIONAL	
7	HISTORICAL LOG OF REC.ID	OPTIONAL	
8	EQUIPMENT SHUTDOWN INSTR	OPTIONAL	
9	RESET REQUEST	REQ/OPT	

Graphical Displays

When the SPS is in RUN or HOLD, graphical formats are available for display. These formats provide graphical outputs of SPS performance data. Each format may contain up to three separate grids with three traces per grid. The formats may also contain criterion plots. Thus, graphical formats are a combination performance evaluation and performance data display in graphical form. Figure 3.1.1-16 presents a typical graphical format. This particular display (GFM 410) contains two grids with one trace per grid. Both grids contain criterion data plots; the crossrange plot identifies boundary limits and the altitude plot identifies nominal conditions.

Figure 3.1.1-16 Graphical Display

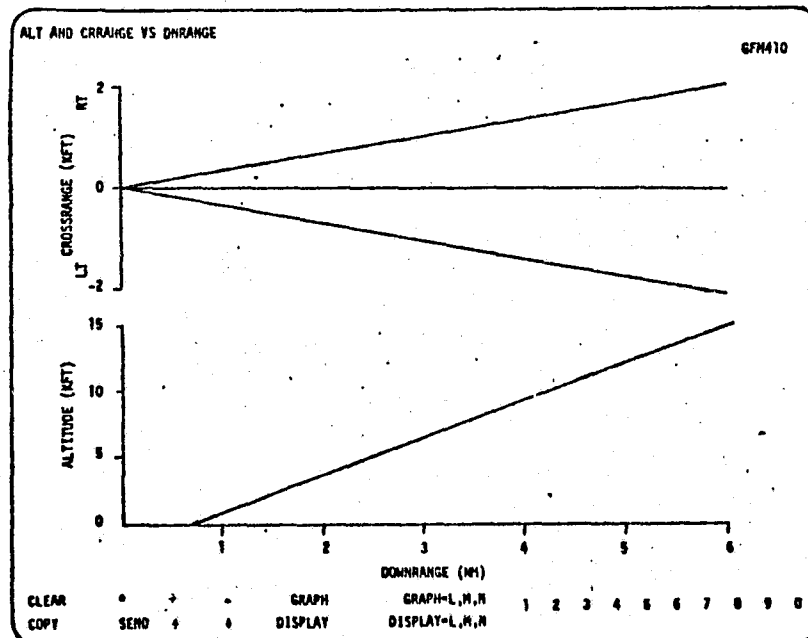

3.2 SPS/PPP Interface

PPP inputs from the SPS are transferred through a common CDC 6400 computer buffer. Reference 3 documents the agreements on the SPS/PPP interface. Figure 3.2-1 illustrates the transfer buffer, which is 59 words long, for the initialization data case and run data case.

For each reset selection, this buffer is first loaded with appropriate initialization data. Table 3.2-1 defines the initialization data parameters.

FIGURE 3.2-1
SPS DATA TRANSFER BUFFER

1	(-1)	INITIALIZATION FLAG	(0)
2			1
3			2
4			3
5			4
6		INITIALIZATION DATA	5
7			6
8			7
9		(A)	8
10			9
11			10
12			11
13			12
14			13
15			14
16			15
17			16
18			1
19			2
20			3
21			4
22		INITIALIZATION DATA	5
23			6
24			7
25		(B)	8
26			9
27			10
28			11
29			12
30			13
31			14
32			15
33			16
34			17
35			18
36			19
37			20
38		INITIALIZATION DATA	21
39			22
40			23
41		(C)	24
42			25
43			26
44			27
45			28
46			29
47			30
48			31
49			32
50			33
51		NOT USED	34
52			35
53			36
54			37
55			38
56			39
57			40
58			41
59			42

TABLE 3.2-1 DEFINITION OF INITIALIZATION DATA TRANSFER FROM SPS

FRAME #	DATA BLOCK RATE	LOCATION #	PARAMETER NAME	PARAMETER DEFINITION,	UNITS	
1-A (1)	--	1	IDATA	-1 INITIALIZATION 0 RUN DATA	-	
		2	PAR 333	LATE START	-	
		3	PAR 334	MISSION PHASE	-	
		4	PAR 367	WIND RANDOM GUST GAIN	-	
		5	PAR 368	WIND PROFILE (1-5)	-	
		6	PAR 369	WIND PEAK SPEED	FT/SEC	
		7	PAR 370	WIND AZIMUTH WRT NORTH	DEG	
		8	PAR 371	-1 SPHERICAL GRAVITY 0	-	
		9	PAR 377	-1 RENDEZVOUS EQUA. 0	-	
		10	PAR 398	GLIDE SLOPE (3.)	DEG	
		11	PAR 399	GLIDE SLOPE DISPLAY RANGE (+.5)	DEG	
		12	PAR 400	LOCALIZER DISPLAY RANGE (+2.5)	DEG	
		13	PAR 401	GLIDE SLOPE ORIGIN (X-RUNWAY = 1200)	FT	
		14	PAR 402	LOCALIZER ORIGIN (X-RUNWAY = 10,000)	FT	
		15	PAR 403	OUTER MARKER ORIGIN (X-RUNWAY = -7)	NM	
		16	PAR 404	MIDDLE MARKER ORIGIN (X RUNWAY = -3500)	FT	
1-B (2)	--	17	PAR 405	X BODY AXIS C.G.	FT	
		18	PAR 406	Y BODY AXIS C.G.	FT	
		19	PAR 407	Z BODY AXIS C.G.	FT	
		20	PAR 408	CN _B WRT CG (NON-NOMINAL)	1/RAD	
		21	PAR 409	CN _B WRT CG (NON-NOMINAL)	1/RAD	
		22	PAR 410	CN _B WRT CG (NON-NOMINAL)	1/RAD	
		23	PAR 411	DESIRED INITIAL GLIDE SLOPE ANGLE	DEG	
		24	PAR 412	ALTITUDE FOR GLIDE SLOPE TRANSITION	FT	
		25	PAR 413	CN DELTA GAIN	-	
		26	PAR 414	CA DELTA GAIN	-	
		27	PAR 415	ROLL - MAX. RHC RANGE	DEG	
		28	PAR 416	PITCH - MAX. RHC RANGE	DEG	
		29	PAR 417	YAW-MAX. RHC RANGE	DEG	
		30	PAR 418	RHC THRESHOLD	DEG	
		31	PAR 419	ROLL RHC GAIN RATIO	-	
		32	PAR 420	PITCH RHC GAIN RATIO	-	
1-C	--	33	PAR 421	YAW RHC GAIN RATIO	-	
		34	PAR 422	DENSITY RATIO	-	
		35	PAR 423	MAX. BANK ACCELERATION (1.5)	DEG/SEC ²	
		36	PAR 424	MAX. BANK RATE (8.)	DEG/SEC	
		37	PAR 435	LONGITUDE BLACKOUT ERROR	DEG	
		38	PAR 436	LATITUDE BLACKOUT ERROR	DEG	
		39	PAR 491	DU #1 INITIAL DISPLAY	-	
		40	PAR 492	DU #2 INITIAL DISPLAY	-	
		41	PAR 493	DU #3 INITIAL DISPLAY	-	
		42	PAR 498	≠0 CALCOMP DATA TAPE =0 NO TAPE	-	
		43	PAR 499	PRINT ID NUMBER	-	
		44				
		thru	NONE			
		48				

NOTE: (1) LOCATION 1 OF PERFORMANCE DATA
(2) LOCATION 1 OF PROCEDURES DATA

As the simulation goes to run, the transfer buffer is loaded with run data by the SPS each comp cycle. A comp cycle is that period of time during which the basic PPP and SPS equations are processed. The transferred data is maximized by packing of discrete parameters (maximum of 60 per word) and through multiplexing techniques.

Table 3.2-2 defines the procedures data transfer. During a simulation run, the transfer buffer (Figure 3.2-1) is loaded by the SPS and contains alternately odd and even frame procedures data. This provides discrete procedural data every comp cycle, and a complete set of procedures data (analog and discrete) every 2 comp cycles. Tables 3.2-3, 3.2-4, 3.2-5, and 3.2-6 present a detailed description of the SPS discrete data words transferred from the SPS. Table 3.2-3 describes the ADLC 1 INPUT discrete words, Table 3.2-4 describes the ADLC 2 INPUT discrete words, Table 3.2-5 describes the ADLC 1 OUTPUT discrete words, and finally Table 3.2-6 describes the ADLC 2 OUTPUT discrete word. Each bit within these words represents the status (BIT=1 for on, and BIT=0 for off) of all the switches, circuit breakers, talkback, and status indicators currently activated in the SPS.

Table 3.2-7 defines the performance data transfer. During the simulation run, the transfer buffer contains one of the 20 frames of performance data. Each comp cycle the transfer buffer is loaded by the SPS with a new frame of data which the PPP reads and processes. A complete set of performance data is transferred in 20 comp cycles.

TABLE 3.2-2 DEFINITION OF PROCEDURES DATA TRANSFER FROM SPS

INBUF LOCATION	PARAMETER NAME	PARAMETER DESCRIPTION
1	TIME	SIMULATION RUN TIME
2 3 4 5 6 7	IDISIN1 (1) IDISIN1 (2) IDISIN1 (3) IDISIN1 (4) IDISIN1 (5) IDISIN1 (6)	ADLC#1 INPUT DISCRETES (SEE TABLE 3.2-3)
8 9 10 11		SPARE SPARE SPARE SPARE RESERVED FOR A TO D VARIABLES
12 13 14	RHC (1) RHC (2) RHC (3)	ROTATIONAL HAND CONTROLLER - PITCH ROTATIONAL HAND CONTROLLER - ROLL ROTATIONAL HAND CONTROLLER - YAW
15	MODESPS	SPS MODE FLAG 1 = HOLD 3 = OPERATE 2 = RESET 10 = ERROR
16 17 18 19 20 21	IDISIN2 (1) IDISIN2 (2) IDISIN2 (3) IDISIN2 (4) IDISIN2 (5) IDISIN2 (6)	ADLC#2 INPUT DISCRETES (SEE TABLE 3.2-4)
22 23 24 25 26 27	IDISOT2 (1) IDISOT2 (2) IDISOT2 (3) IDISOT2 (4) IDISOT2 (5) IDISOT2 (6)	ADLC#2 OUTPUT DISCRETES (SEE TABLE 3.2-5)
28 29	MAL (1) MAL (2)	MALFUNCTION CODE WORD
30 31 32 33 34	NCRT (1) NCRT (2) NCRT (3) NCRT (4) NCRT (5)	CRT FORMAT NUMBER - LEFT CRT FORMAT NUMBER - CENTER CRT FORMAT NUMBER - RIGHT CRT FORMAT NUMBER - MISSION SPECIALIST CRT FORMAT NUMBER - PGP
35 36 37	IDISOT1 (1) IDISOT1 (2) IDISOT1 (3)	ADLC#1 OUTPUT DISCRETES (SEE TABLE 3.2-6)

ODD FRAMES

TABLE 3.2-2 DEFINITION OF PROCEDURES DATA TRANSFER FROM SPS (Cont'd)

EVEN FRAME CONTINUED	INBUF LOCATION	PARAMETER NAME	PARAMETER DESCRIPTION
	30	NCRT (1)	CRT FORMAT NUMBER - LEFT
	31	NCRT (2)	CRT FORMAT NUMBER - CENTER
	32	NCRT (3)	CRT FORMAT NUMBER - RIGHT
	33	NCRT (4)	CRT FORMAT NUMBER - MISSION SPECIALIST
	34	NCRT (5)	CRT FORMAT NUMBER - PGP
	35	IDISOT1 (1)	ADLC#1 OUTPUT DISCRETES (SEE TABLE 3.2-6)
36	IDISOT1 (2)		
37	IDISOT1 (3)		
38	IDISOT1 (4)		
39	IDISOT1 (5)		
40	IDISOT1 (6)		
41		SPARE	
42	IFRAME	FRAME COUNTER	

TABLE 3.2-3
ADLC1 INPUT DISCRETE LIST (1 OF 6)

BUFFER PARAMETER		DESCRIPTION	PANEL	POSITION	6400-ADLC1 DISCRETE CHANNEL
VARIABLE NAME	BIT				
IDISINI (1)	60	KB1 ROW 0	C2L ↑ ↓		1
	59	KB1 ROW 1			2
	58	KB1 ROW 2			3
	57	KB1 ROW 3			4
	56	KB1 ROW 4			5
	55	KB1 ROW 5			6
	54	KB1 ROW 6			7
	53	KB1 ROW 7			8
	52	KB1 COL 1			9
	51	KB1 COL 2			10
	50	KB1 COL 3	11		
	49	KB1 COL 4	C2L PPP		12
	48	KB2 ROW 0	PPP ↑ ↓		13
	47	KB2 ROW 1			14
	46	KB2 ROW 2			15
	45	KB2 ROW 3			16
	44	KB2 ROW 4			17
	43	KB2 ROW 5			18
	42	KB2 ROW 6			19
	41	KB2 ROW 7			20
	40	KB2 COL 1			21
	39	KB2 COL 2			22
	38	KB2 COL 3	PPP C2R ↑ ↓		23
	37	KB2 COL 4			24
	36	KB3 ROW 0			25
	35	KB3 ROW 1			26
	34	KB3 ROW 2			27
	33	KB3 ROW 3			28
	32	KB3 ROW 4			29
	31	KB3 ROW 5			30
	30	KB3 ROW 6			31
	29	KB3 ROW 7			32
	28	KB3 COL 1	C2R		33
	27	KB3 COL 2			34
	26	KB3 COL 3			35
	25	KB3 COL 4			36
	24	KB4			37
	23	KB4			38
	22	KB4			39
	21	KB4			40
	20	KB4			41
	19	KB4			42
	18	KB4	C2 ↑ ↓		43
	17	KB4			44
	16	KB4			45
	15	KB4			46
	14	KB4			47
	13	KB4			48
	12	CRT1-GNC			49
	11	CRT1-SM			50
	10	CRT1-PL			51
	9	CRT3-GNC			52
	8	CRT3-SM	53		
	7	CRT3-PL	54		
	6	CRT2-GNC	55		
	5	CRT2-SM	56		
	4	CRT2-PL	57		
	3	KB SEL-LEFT	58		
	2	KB SEL-OFF	59		
	1	KB SEL-RIGHT	C2		60

TABLE 3.2-3

ADLC1 INPUT DISCRETE LIST (2 OF 6)

BUFFER PARAMETER		DESCRIPTION	PANEL	POSITION	6400-ADLC1 DISCRETE CHANNEL	
VARIABLE NAME	BIT					
IDISIN1 (2)	60	BFC ENGAGE		DEPRESS	61	
	59	BODY FLAP		DEPRESS	62	
	58	ROLL/YAW DIR		DEPRESS	63	
	57	ROLL/YAW CSS		DEPRESS	64	
	56	ROLL/YAW AUTO		DEPRESS	65	
	55	PITCH DIR		DEPRESS	66	
	54	PITCH CSS		DEPRESS	67	
	53	PITCH AUTO		DEPRESS	68	
	52					69
	51	QTY IND SEL		07	OMS L	70
	50	QTY IND SEL		07	OMS R	71
	49	QTY IND SEL		07	RCS L	72
	48	QTY IND SEL		07	RCS FWD	73
	47	QTY IND SEL		07	RCS R	74
	46	TACAN 1		C3	AUTO	75
	45	TACAN 1		C3	T/R	76
	44	TACAN 1		C3	RCV	77
	43	TACAN 2		C3	AUTO	78
	42	TACAN 2		C3	T/R	79
	41	TACAN 2		C3	RCV	80
	40	TACAN 3		C3	AUTO	81
	39	TACAN 3		C3	T/R	82
	38	TACAN 3		C3	RCV	83
	37	FDAI SEL		L2	EULER	84
	36	ADI RATE		F6	1	85
	35	ADI RATE		F6	10	86
	34	ADI ERROR		F6	1	87
	33	ADI ERROR		F6	20	88
	32	HIGH RATE TRIM ROLL		L2	L	89
	31	HIGH RATE TRIM ROLL		L2	R	90
	30	HIGH RATE TRIM ROLL		C3	L	91
	29	HIGH RATE TRIM ROLL		C3	R	92
	28	FDAI MODE		L2	ARTIF HORIZ	93
	27					94
	26	PRI FCS		F6	RESET	95
	25	SPEED BRAKE THRUST CNTRL		C3	TAKEOVER	96
	24	HSI SELECT SOURCE		F6	TACAN	97
	23	HSI SELECT SOURCE		F6	MLS	98
	22	HSI SELECT SOURCE		F6	1	99
	21	HSI SELECT SOURCE		F6	3	100
	20	ANTI-SKID		L2	ON	101
	19	NWS		L2	CMPTR	102
	18	NWS		L2	DIRECT	103
	17	TRIM PITCH		C3	UP	104
	16	TRIM PITCH		C3	DWN	105
15	RIGHT CNTRL POWER		F9	ON	106	
14	BODY FLAP		C3	UP	107	
13	YAW TRIM		L2	L	108	
12	YAW TRIM		L2	R	109	
11	BODY FLAP		L2	UP	110	
10	BODY FLAP		L2	DWN	111	
9	MAN TRIM ROLL		F8	ENABLE	112	
8	MAN TRIM PITCH		F8	ENABLE	113	
7	MAN TRIM YAW		F8	POWER-OFF	114	
6	YAW TRIM		C3	L	115	
5	YAW TRIM		C3	R	116	
4	RDR ALT		F8	1	117	
3	ADI ERROR		F8	1	118	
2	ADI ERROR		F8	20	119	
1	ADI RATE		F8	1	120	

TABLE 3.2-3

ADLC1 INPUT DISCRETE LIST (3 OF 6) (Cont'd)

BUFFER PARAMETER		DESCRIPTION	PANEL	POSITION	6400-ADLC1 DISCRETE CHANNEL
VARIABLE NAME	BIT				
IDISIN1 (3)	60	ADI RATE	F8	10	121
	59	TRIM PITCH	L2	UP	122
	58	TRIM PITCH	L2	DWN	123
	57	HSI SELECT SOURCE	F8	TACAN	124
	56	HSI SELECT SOURCE	F8	MLS	125
	55	HSI SELECT SOURCE	F8	1	126
	54	HSI SELECT SOURCE	F8	3	127
	53	LEFT CONT PWR	L1	OM	128
	52	RDR ALTM	F6	1	129
	51	BODY FLAP	C3	DOWN	130
	50	HSI SELECT MODE	F6	ENTRY	131
	49	HSI SELECT MODE	F6	APPROACH	132
	48	AIR DATA SELECT	F6	RIGHT	133
	47	AIR DATA SELECT	F6	LEFT	134
	46	MAN TRIM ROLL	F6	ENABLE	135
	45	MAN TRIM PITCH	F6	ENABLE	136
	44	MAN TRIM YAW	F6	PWR-ON	137
	43	LANDING GEAR		DWN	138
	42	LANDING GEAR		ARM	139
	41	SPEED BRAKE THRUST	L2	TAKEOVER	140
	40	COMPUTER OPERATE		OPERATE	141
	39	COMPUTER HOLD			142
	38	PPP ROTARY SW		PPP	143
	37	PPP ROTARY SW		LEFT CRT	144
	36	PPP ROTARY SW		CENTER CRT	145
	35	PPP ROTARY SW		RIGHT CRT	146
	34	PPP ROTARY SW		PMF	147
	33	PPP ROTARY SW		C/S	148
	32	PPP DISPLAY FREEZE			149
	31	PPP QUE			150
	30	PPP SPARE			151
	29	PPP SPARE			152
	28	PPP SPARE			153
	27	PPP SPARE			154
	26	PPP (TRUE-WITH, FALSE-WITHOUT PGP)			155
	25	930 (TRUE-CONNECTED)			156
	24	9300 (TRUE-CONNECTED)			157
	23	REAL TIME ROLLOUT			158
	22	NEW IC			159
	21	PPP TAPE PUMP			160
	20	CALCOMP DATA PUMP			161
	19	DUMP DATA TO TAPE			162
	18	INITIALIZE DATA LOG			163
	17	UNLOAD DATA TAPE			164
	16	ZERO DTOAS			165
	15	DATA LOG ON/OFF			166
	14	6400 LINE PRINTER REQ			167
	13				168
	12				169
	11				170
	10				171
	9				172
	8				173
	7				172
	6	MINIMUM ENERGY			175
	5	PENICANCE FOR 6400			176
	4	PEN IC ON			177
	3	PEN OUTPUT ON			178
	2	XYZ PLOTTER IC ON			179
	1	XYZ PLOTTER OUTPUT ON			180

TABLE 3.2-3

ADLC1 INPUT DISCRETE LIST (4 OF 6) (Cont'd)

BUFFER PARAMETER		DESCRIPTION	PANEL	POSITION	6400-ADLC1 DISCRETE CHANNEL
VARIABLE NAME	BIT				
IDISIN1 (4)	60	HSI SELECT MODE	F8	ENTRY	181
	59	HSI SELECT MODE	F8	APPROACH	182
	58	AIR DATA SELECT	F8	RIGHT	183
	57	AIR DATA SELECT	F8	LEFT	184
	56	BFC ENGAGE	F2	DEPRESS	185
	55	BODY FLAP	F2	DEPRESS	186
	54	SPEED BRAKE	F2	DEPRESS	187
	53	SPEED BRAKE	F4	DEPRESS	188
	52	ROLL/YAW DIR	F2	DEPRESS	189
	51	ROLL/YAW CSS	F2	DEPRESS	190
	50	ROLL/YAW AUTO	F2	DEPRESS	191
	49	PITCH DIR	F2	DEPRESS	192
	48	PITCH CSS	F2	DEPRESS	193
	47	PITCH AUTO	F2	DEPRESS	194
	46	ROLL TRIM	HCL	RIGHT	195
	45	ROLL TRIM	HCL	LEFT	196
	44	PITCH TRIM	HCL	UP	197
	43	PITCH TRIM	HCL	DOWN	198
	42	COMM SW	HCL	ON	199
	41	ROLL H/C BREAKOUT	HCL	ON	200
	40	PITCH H/C BREAKOUT	HCL	ON	201
	39	YAW H/C BREAKOUT	HCL	ON	202
	38	MANUAL OVERRIDE	HCL	ON	203
	37	ACTUATOR BYPASS (VISUAL SW1)			204
	36	PITCH STEP (VISUAL SW2)			205
	35	YAW STEP (VISUAL SW3)			206
	34	SPEED BRAKE STEP (VISUAL SW4)			207
	33	NEW RANDOM NUMBERS (VISUAL SW5)			208
	32	BATCH 211 TERMINAL DISCRETE			209
	31	C/S 211 TERMINAL DISCRETE			210
	30	TACAN CHANNEL 1		HUND 1	211
	29	TACAN CHANNEL 2		HUND 1	212
	28	TACAN CHANNEL 3		HUND 1	213
	27	TACAN CHANNEL 1		TENS 1	214
	26	TACAN CHANNEL 1		TENS 2	215
	25	TACAN CHANNEL 1		TENS 4	216
	24	2		TENS 8	217
	23	2		TENS 1	218
	22	2		TENS 2	219
	21	2		TENS 4	220
	20	2		TENS 8	221
	19	3		TENS 1	222
	18	3		TENS 2	223
	17	3		TENS 4	224
	16	3		TENS 8	225
	15	1		UNIT 1	226
	14	1		UNIT 2	227
13	1		UNIT 4	228	
12	1		UNIT 8	229	
11	2		UNIT 1	230	
10	2		UNIT 2	231	
9	2		UNIT 4	232	
8	2		UNIT 8	233	
7	3		UNIT 1	234	
6	3		UNIT 2	235	
5	3		UNIT 4	236	
4	3		UNIT 8	237	
3	1		XORY X	238	
2	2		XORY X	239	
1	3	TACAN CHANNEL 3		XORY X	240

TABLE 3.2-3

ADLC1 INPUT DISCRETE (5 OF 6) (Cont'd)

BUFFER PARAMETER		DESCRIPTION	PANEL	POSITION	6400-ADLC1 DISCRETE CHANNEL
VARIABLE NAME	BIT				
IDISIN1 (5)	60	ROLL TRIM	HCR	RIGHT	241
	59	ROLL TRIM	HCR	LEFT	242
	58	PITCH TRIM	HCR	UP	243
	57	PITCH TRIM	HCR	DOWN	244
	56	RHC ROLL	HCR		245
	55	RHC PITCH	HCR		246
	54	RHC YAW	HCR		247
	53	COMM	HCR	ON	248
	52	MANUAL OVERRIDE	HCR	ON	249
	51				250
	50				251
	49				252
	48				253
	47				254
	46				255
	45				256
	44				257
	43				258
	42				259
	41				260
	40				261
	39				262
	38				263
	37				264
	36				265
	35				266
	34				267
	33				268
	32				269
	31				270
30				271	
29				272	
28				273	
27				274	
26				275	
25				276	
24				277	
23				278	
22				279	
21				280	
20				281	
19				282	
18				283	
17				284	
16				285	
15				286	
14				287	
13				288	
12				289	
11				290	
10				291	
9				292	
8				293	
7				294	
6				295	
5				296	
4				297	
3				298	
2				299	
1				300	

TABLE 3.2-3

ADLC1 INPUT DISCRETE LIST (6 OF 6) (Cont'd)

BUFFER PARAMETER		DESCRIPTION	6400-ADLC1 DISCRETE CHANNEL
VARIABLE NAME	BIT		
IDISIN1 (6)	60		301
	59		302
	58		303
	57		304
	56		305
	55		306
	54		307
	53		308
	52		309
	51		310
	50		311
	49		312
	48		313
	47		314
	46		315
	45		316
	44		317
	43		318
	42		319
	41		320
	40		321
	39		322
	38		323
	37		324
	36		325
	35		326
	34		327
	33		328
	32		329
	31		330
	30		331
	29		332
	28		333
	27		334
	26		335
	25		336
	24		337
	23		338
	22		339
	21		340
	20		341
	19		342
	18		343
	17		344
	16		345
	15		346
	14		347
	13		348
	12		349
	11		350
	10		351
	9		352
	8		353
	7		354
	6		355
	5		356
	4		357
	3		358
	2		359
	1		360

TABLE 3.2-4

ADLC2 INPUT DISCRETE LIST (1 OF 6)

BUFFER PARAMETER		DESCRIPTION	PANEL	POSITION	6400-ADLC2 DISCRETE CHANNEL
VARIABLE NAME	BIT				
IDISIN2 (1)	60	IMU POWER 2	07	ON	1
	59	INV 1 POWER OA-CB	C3	IN	2
	58	INV 1 POWER OB-CB	C3	IN	3
	57	INV 1 POWER OC-CB	C3	IN	4
	56	INV 2 POWER OA-CB	C3	IN	5
	55	INV 2 POWER OB-CB		IN	6
	54	INV 2 POWER OC-CB		IN	7
	53	INV 3 POWER OA-CB		IN	8
	52	INV 3 POWER OB-CB		IN	9
	51	INV 3 POWER OC-CB		IN	10
	50	AC1 BUS OA-CB		IN	11
	49	AC1 BUS OB-CB		IN	12
	48	AC1 BUS OC-CB		IN	13
	47	AC2 BUS OA-CB		IN	14
	46	AC2 BUS OB-CB		IN	15
	45	AC2 BUS OC-CB		IN	16
	44	AC3 BUS OA-CB		IN	17
	43	AC3 BUS OB-CB		IN	18
	42	AC3 BUS OC-CB		IN	19
	41	FUEL CELL 1 PUMP AC10A-CB		IN	20
	40	FUEL CELL 2 PUMP AC20A-CB		IN	21
	39	FUEL CELL 3 PUMP AC30A-CB	C3	IN	22
	38	APU SPEED SELECT 1-SW	R2	HIGH	23
	37	APU SPEED SELECT 2-SW	R2	HIGH	24
	36	APU SPEED SELECT 3-SW	R2	HIGH	25
	35	UHF 1 PWR-SW	C3	OFF	26
	34	UHF 2 PWR-SW	C3	OFF	27
	33	MLS 1 SW	C3	ON	28
	32	MLS 2 SW	C3	ON	29
	31	MLS 3 SW	C3	ON	30
	30	FUEL CELL CONTROL 1 SW	R2	STOP	31
	29	FUEL CELL CONTROL 2 SW	R2	STOP	32
	28	FUEL CELL CONTROL 3 SW	R2	STOP	33
	27	APU CONTROL PWR 1 SW	R2	ON	34
	26	APU CONTROL PWR 2 SW	R2	ON	35
	25	APU CONTROL PWR 3 SW	R2	ON	36
	24	APU SPEED SEL 1 SW	R2	LOW	37
	23	APU SPEED SEL 2 SW	R2	LOW	38
	22	APU SPEED SEL 3 SW	R2	LOW	39
	21	APU AUTO SHUTDOWN SW	R2	ENABLE	40
	20	APU CONTROL 1	R2	START/RUN	41
	19	APU CONTROL 2	R2	START/RUN	42
	18	APU CONTROL 3	R2	START/RUN	43
	17	FUEL TANK VALVE 1	R2	OPEN	44
	16	FUEL TANK VALVE 2	R2	OPEN	45
	15	FUEL TANK VALVE 3	R2	OPEN	46
	14	HYD H2O BOILER X-FER VALVE 1 SW	R2	OPEN	47
	13	HYD H2O BOILER X-FER VALVE 2 SW	R2	OPEN	48
	12	HYD BOILER X-FER VALVE 3 SW	R2	OPEN	49
	11	IMU PWR 3 SW	07	ON	50
	10	HPG TANK VLV H2 TK 1 SW	R2	OPEN	51
	9	HPG TANK VLV H2 TK 2 SW	R2	OPEN	52
	8	HPG TANK VLV O2 TK 1 SW	R2	OPEN	53
	7	HPG TANK VLV O2 TK 2 SW	R2	OPEN	54
	6	HPG TANK VLV H2 TK 1 SW	R2	CLOSED	55
	5	HPG TANK VLV H2 TK 2 SW	R2	CLOSED	56
	4	HPG TANK VLV O2 TK 1 SW	R2	CLOSED	57
	3	HPG TANK VLV O2 TK 2 SW	R2	CLOSED	58
	2	HPG MANE ISOL/CRSFD VLV H2 TK 1 SW	R2	OPEN	59
	1	HPG MANE ISOL/CRSFD VLV H2 TK 2 SW	R2	OPEN	60

* DUPLICATE DATA TRANSFERRED IN ADLC1. USE ADLC1 INPUTS PER ART NOLTING (2/5/75)

TABLE 3.2-4.

ADLC2 INPUT DISCRETE LIST (2 OF 6) (Cont'd)

BUFFER PARAMETER		DESCRIPTION	PANEL	POSITION	6400-ADLC DISCRETE CHANNEL
VARIABLE NAME	BIT				
IDISIN2 (2)	60	HGP MANF ISOL/CRSFD VLV O2 TK 1 SW	R2	OPEN	61
	59	HPG MANF ISOL/CRSFD VLV O2 TK 2 SW	R2	OPEN	62
	58	HPG MANF ISOL/CRSFD VLV H2 TK 1 SW	R2	CLOSED	63
	57	HGP MANF ISOL/CRSFD VLV H2 TK 2 SW	R2	CLOSED	64
	56	HGP MANF ISOL/CRSFD VLV O2 TK 1 SW	R2	CLOSED	65
	55	HPG MANF ISOL/CRSFD VLV O2 TK 2 SW	R2	CLOSED	66
	54	FUEL CELL REACTANTS 1 SW	R2	OPEN	67
	53	FUEL CELL REACTANTS 2 SW	R2	OPEN	68
	52	FUEL CELL REACTANTS 3 SW	R2	OPEN	69
	51	FUEL CELL CONTROL 1 SW	R2	START	70
	50	FUEL CELL CONTROL 2 SW	R2	START	71
	49	FUEL CELL CONTROL 3 SW	R2	START	72
	48	FUEL CELL REACTANTS 1 SW	R2	CLOSED	73
	47	FUEL CELL REACTANTS 2 SW	R2	CLOSED	74
	46	FUEL CELL REACTANTS 3 SW	R2	CLOSED	75
	45	APU CONTROL 1 SW	R2	START OVER- RIDE/RUN	76
	44	APU CONTROL 2 SW	R2	START OVER- RIDE/RUN	77
	43	APU CONTROL 3 SW	R2	START OVER- RIDE/RUN	78
	42	NWS *	L2	CMPTR	79
	41	ANTI SKID *	L2	ON	80
	40	CABIN TEMP CONT	L2	PRI	81
	39	CABIN TEMP CONT	L2	SEC	82
	38	LEFT CONTROLLER PWR*	L1	ON	83
	37	LEFT AIR DATA PROBE	C3	DEPLOY	84
	36	LEFT AIR DATA PROBE	C3	STOW	85
	35	RIGHT AIR DATA PROBE	C3	DEPLOY	86
	34	RIGHT AIR DATA PROBE	C3	STOW	87
	33	HYD MAIN PUMP PRESS 1 SW	R2	NORMAL	88
	32	HYD MAIN PUMP PRESS 2 SW	R2	NORMAL	89
	31	HYD MAIN PUMP PRESS 3 SW	R2	NORMAL	90
	30	C&W LIMIT SET VALUE HUNDRTH THWL	R12	1	91
	29	C&W LIMIT SET VALUE TENTHS THWL	R12	1	92
	28	C&W LIMIT SET VALUE TENTHS THWL	R12	2	93
	27	C&W LIMIT SET VALUE TENTHS THWL	R12	4	94
	26	C&W LIMIT SET VALUE TENTHS THWL	R12	8	95
	25	C&W LIMIT SET VALUE UNITS THWL	R12	1	96
	24	C&W LIMIT SET VALUE UNITS THWL	R12	2	97
	23	C&W LIMIT SET VALUE UNITS THWL	R12	4	98
	22	RDR ALTM PWR 1 SW	C3	ON	99
	21	RDR ALTM PWR 2 SW	C3	ON	100
	20	H2O PUMP SEC SW	L1	ON	101
	19	IMU FAN A	L1	ON	102
	18	IMU FAN B	L1	ON	103
	17	H2O BYPASS SEC SW	L1	DECR	104
	16	H2O BYPASS SEC SW	L1	INCR	105
	15	H2O BYPASS SEC SW	L1	MANUAL	106
	14				107
	13	FREON PUMP LOOP 1 SW	L1	ON	108
	12	H2O BYPASS SEC SW	L1	AUTO	109
	11	H2O BYPASS PRI SW	L1	DECR	110

* DUPLICATE DATA TRANSFERRED IN ADLC1. USE ADLC1 INPUTS PFR ART NOLTING (2/5/75)

TABLE 3.2-4

ADLC2 INPUT DISCRETE LIST (2 OF 6) (Cont'd)

BUFFER PARAMETER		DESCRIPTION	PANEL	POSITION	6400-ADLC2 DISCRETE CHANNEL
VARIABLE NAME	BIT				
IDISIN2 (2) (CONTINUED)	10	NH3 TANK VLV 1	L1	OPEN	111
	9	NH3 TANK VLV 2	L1	OPEN	112
	8	H2O BYPASS PRI SW	L1	AUTO	113
	7	NH 3 BOILER FLOW CONTROL B SW	L1	PRI	114
	6	NH 3 BOILER FLOW CONTROL A SW	L1	SEC	115
	5	NH 3 BOILER FLOW CONTROL A SW	L1	PRI	116
	4				117
	3				118
	2				119
	1	FREON PUMP LOOP 2 A SW	L1	ON	120

* DUPLICATE DATA TRANSFERRED IN ADLC1. USE ADLC1 INPUTS PER ART NOLTING (2/5/75)

TABLE 3.2-4

ADLC2 INPUT DISCRETE LIST (3 OF 6) (Cont'd)

BUFFER PARAMETER		DESCRIPTION	PANEL	POSITION	6400-ADLC2 DISCRETE CHANNEL
VARIABLE NAME	BIT				
IDISIN2 (3)	60	AVIONICS BAY 1 FAN A	L1	ON	121
	59	AVIONICS BAY 2 FAN A	L1	ON	122
	58	AVIONICS BAY 3 FAN A	L1	ON	123
	57	CABIN FAN 1 SW	L1	ON	124
	56	CABIN FAN 2 SW	L1	ON	125
	55	NH 3 BOILERS FLOW CONTROL B SW	L1	SEC	126
	54	FCS CHANNEL MONITOR 1 SW	C3	RESET	127
	53	FCS CHANNEL MONITOR 2 SW	C3	RESET	128
	52	FCS CHANNEL MONITOR 3 SW	C3	RESET	129
	51	FCS CHANNEL MONITOR 4 SW	C3	RESET	130
	50	H2O BYPASS PRI SW	L1	MANUAL	131
	49	MASTER ALARM	F2	ON	132
	48	H2O BYPASS PRI SW	L1	INCR	133
	47	AVIONICS BAY 3 FAN B SW	L1	ON	134
	46	AVIONICS BAY 2 FAN B SW	L1	ON	135
	45	AVIONICS BAY 1 FAN B SW	L1	ON	136
	44	H2O PUMP PRI B SW	L1	ON	137
	43	H2O PUMP PRI A SW	L1	ON	138
	42	FCS CHANNEL MONITOR 1 SW	C3	OVERRIDE	139
	41	FCS CHANNEL MONITOR 2 SW	C3	OVERRIDE	140
	40	FCS CHANNEL MONITOR 3 SW	C3	OVERRIDE	141
	39	FCS CHANNEL MONITOR 4 SW	C3	OVERRIDE	142
	38	MASTER ALARM	F4	ON	143
	37	INVERTER PWR 1 SW	R1	ON	144
	36	INVERTER PWR 2 SW		ON	145
	35	INVERTER PWR 3 SW		ON	146
	34	AC BUS 1 SW		ON	147
	33	AC BUS 2 SW		ON	148
	32	AC BUS 3 SW		ON	149
	31	AC BUS 1 SW		OFF	150
	30	AC BUS 2 SW		OFF	151
	29	AC BUS 3 SW		OFF	152
	28	MAIN DC BUS A SW		ON	153
	27	MAIN DC BUS B SW		ON	154
	26	MAIN DC BUS C SW		ON	155
25	MAIN DC BUS A SW		OFF	156	
24	MAIN DC BUS B SW		OFF	157	
23	MAIN DC BUS C SW		OFF	158	
22	DC TIE BUS MN A SW	R1	ON	159	
21	DC TIE BUS MN B SW		ON	160	
20	DC TIE BUS MN C SW		ON	161	
19	DC TIE BUS MN A SW		OFF	162	
18	DC TIE BUS MN B SW		OFF	163	
17	DC TIE BUS MN C SW		OFF	164	
16	E SS BUS SOURCE 1 BC FC SW		ON	165	
15	E SS BUS SOURCE 2 AC FC SW		ON	166	
14	E SS BUS SOURCE 3 AB FC SW		ON	167	
13	E SS BUS SOURCE 1 BC MN SW		ON	168	
12	E SS BUS SOURCE 2 AC MN SW		ON	169	
11	E SS BUS SOURCE 3 AB MN SW		ON	170	
10	AC BUS SENSOR 1 SW		AUTO TRIP	171	
9	AC BUS SENSOR 2 SW		AUTO TRIP	172	
8	AC BUS SENSOR 3 SW		AUTO TRIP	173	
7	AC BUS SENSOR 1 SW		MONITOR	174	

* DUPLICATE DATA TRANSFERRED IN ADLC1. USE ADLC1 INPUTS PER ART NOLTING (2/5/75)

TABLE 3.2-4

ADLC2 INPUT DISCRETE LIST (3 OF 6) (Cont'd)

BUFFER PARAMETER		DESCRIPTION	PANEL	POSITION	6400-ADLC DISCRETE CHANNEL
VARIABLE NAME	BIT				
IDISIN2 (3) (CONTINUED)	6	AC BUS SENSOR 2 SW	R1	MONITOR	175
	5	AC BUS SENSOR 3 SW		MONITOR	176
	4	AC DISPLAY SW		BUS 1 OB	177
	3	AC DISPLAY SW		BUS 1 OC	178
	2	AC DISPLAY SW		BUS 2 OA	179
	1	AC DISPLAY SW		BUS 2 OB	180

* DUPLICATE DATA TRANSFERRED IN ADLC1. USE ADLC1 INPUTS PER ART NOLTING (2/5/75)

TABLE 3.2-4

ADLC2 INPUT DISCRETE LIST (4 OF 6)

BUFFER PARAMETER VARIABLE NAME	BIT	DESCRIPTION	PANEL	POSITION	6400-ADLC2 DISCRETE CHANNEL
IDISIN2 (4)	60	AC DISPLAY SW	R1	BUS 2 OC	181
	59	AC DISPLAY SW	↑ R1 ↓ R12 ↓ R12	BUS 3 OA	182
	58	AC DISPLAY SW		BUS 3 OB	183
	57	AC DISPLAY SW		BUS 3 OC	184
	56	DC DISPLAY E SS BUS SW		2 CA	185
	55	DC DISPLAY E SS BUS SW		3 AB	186
	54	DC DISPLAY MN BUS SW		A	187
	53	DC DISPLAY MN BUS SW		B	188
	52	DC DISPLAY MN BUS SW		C	189
	51	DC DISPLAY FUEL CELL SW		1	190
	50	DC DISPLAY FUEL CELL SW		2	191
	49	DC DISPLAY FUEL CELL SW		3	192
	48	PARAMETER SELECT DIG UNITS		R12	ONE
	47	PARAMETER SELECT DIG UNITS		TWO	194
	46	PARAMETER SELECT DIG UNITS		FOUR	195
	45	PARAMETER SELECT DIG UNITS		EIGHT	196
	44	PARAMETER SELECT DIG TENS		ONE	197
	43	PARAMETER SELECT DIG TENS		TWO	198
	42	PARAMETER SELECT DIG TENS		FOUR	199
	41	PARAMETER SELECT DIG TENS		EIGHT	200
	40	PARAMETER SELECT DIG HUNDREDS	R12	ONE	201
	39	CABIN PRESS MNA SW	L4	IN	202
	38	SIGNAL COND CAB AIR AC 1 OC CB	L4	IN	203
	37	STATUS LAMP TEST	R12	LEFT	204
	36	STATUS LAMP TEST	R12	RIGHT	205
	35	RATE GYRO 1 MNA SW	R4	ON	206
	34	RATE GYRO 2 MNB SW	R4	ON	207
	33	RATE GYRO 3 MNC SW	R4	ON	208
	32	ACCELEROMETERS 1 MNA CB	R4	IN	209
	31	ACCELEROMETERS 2 MNB CB	R4	IN	210
	30	ACCELEROMETERS 3 MNC CB	R4	IN	211
	29	SIGNAL COND A/B 2 OB CB	L4	IN	212
	28	SIGNAL COND A/B 1 AC 1 OB CB	L4	IN	213
	27	H2O PUMP SEC AC 3 OA CB	L4	IN	214
	26	H2O PUMP PRI B AC OA CB	L4	IN	215
	25	H2O PUMP PRI A AC 1 OA CB	L4	IN	216
	24	NH3 TK VLV MN A CB	L4	IN	217
	23	AIR DATA TRANSOURCER LEFT 3 MNC	R4	IN	218
	22	FREON PUMP LOOP 1 AC OA CB	L4	IN	219
	21	MTN 1 ESS 2 CA CB	L4	IN	220
	20	MTN 1 ESS 1 AB CB	L4	IN	221
	19	CW ESS 1 BC SW	R4	ON	222
	18	SIGNAL COND A/B 3 AC 3 OB CB	L4	IN	223
	17	CABIN FAN 2 AC 2 OA CB	L4	IN	224
	16	H2O BYPASS CONTROL SEC AC 3 OC CB	L4	IN	225
	15	H2O BYPASS CONTROL PRI AC 2 OC CB	L4	IN	226
	14	AIR DATA TRANSDUCER RIGHT 4 MNC CB	R4	IN	227
	13	FREON LOOP 2 PUMP A AC 2 OA CB	L4	IN	228

* DUPLICATE DATA TRANSFERRED IN ADLC1. USE ADLC1 INPUTS PER ART NOLTING (2/5/75)

TABLE 3.2-4

ADLC2 INPUT DISCRETE LIST (4 OF 6) (Cont'd)

BUFFER PARAMETER		DESCRIPTION	PANEL	POSITION	6400-ADLC DISCRETE CHANNEL
VARIABLE NAME	BIT				
IDISIN2 (4) (CONTINUED)	12	NH3 TK VLV MN C CB	L4	IN	229
	11	NH3 TK VLV MN B CB	L4	IN	230
	10	AERO SURFACE AMP 1 SW	R4	ON	231
	9	AIR DATA TRANSDUCERS LEFT 1 MNA	R4	IN	232
	8	CW ESS 2 CA SW	R4	ON	233
	7	CABIN TEMP CONTROL SEC AC 2 OC CB	L4	IN	234
	6	CABIN TEMP CONTROL PRI AC1 OA CB	L4	IN	235
	5	CABIN FAN 1 AC OA CB	L4	IN	236
	4	NH3 TANK VLV TK1 SW B	L1	OPEN	237
	3	NH3 TANK VLV TK2 SW C	L1	OPEN	238
	2				239
	1				240

* DUPLICATE DATA TRANSFERRED IN ADLC1. USE ADLC1 INPUTS PER ART NOLTING (2/5/75)

TABLE 3.2-4

ADLC2 INPUT DISCRETE LIST (5 OF 6) (Cont'd)

BUFFER PARAMETER		DESCRIPTION	PANEL	POSITION	6400-ADLC DISCRETE CHANNEL
VARIABLE NAME	BIT				
IDISIN2 (5)	60	AERO SURFACE AMP 2 SW	R4	ON	241
	59	DISPLAY SEL SW	O2	1	242
	58	AVIONICS BAY 3 FAN B AC 2 OA CB	L4	IN	243
	57	DISPLAY SEL SW	O2	3	244
	56	AVIONICS BAY 2 FAN B AC 3 OA CB	L4	IN	245
	55	AVIONICS BAY 1 FAN B AC 3 OA CB	L4	IN	246
	54	EPD FWD LOAD CNTRL ESS 1 BC CB	R4	IN	247
	53	EPD FWD LOAD CNTRL ESS 2 CA CB	R4	IN	248
	52	EPD FWD LOAD CNTRL ESS 3 AB CB	R4	IN	249
	51	EPD FWD LOAD CNTRL NO 1 MNA SW	R4	ON	250
	50	EPD FWD LOAD CNTRL NO 2 MNB SW	R4	ON	251
	49	EPD FWD LOAD CNTRL NO 3 MNC SW	R4	ON	252
	48	EPD AFT LOAD CNTRL NO 1 MNA SW	R4	ON	253
	47	EPD AFT LOAD CNTRL NO 2 MNB SW	R4	ON	254
	46	EPD AFT LOAD CNTRL NO 3 MNC SW	R4	ON	255
	45	DC TIE BUS CONTROL ESS 1 BC CB	R4	IN	256
	44	DC TIE BUS CONTROL ESS 2 CA CB	R4	IN	257
	43	DC TIE BUS CONTROL ESS 3 AB CB	R4	IN	258
	42	AC BUS SENSOR 1 MNA CB	R4	IN	259
	41	AC BUS SENSOR 2 MNB CB	R4	IN	260
	40	AC BUS SENSOR 3 MNC CB			261
	39	FUEL CELL CONTROL ESS 1 BC CB	R4	IN	262
	38	FUEL CELL CONTROL ESS 2 CA CB	R4	IN	263
	37	FUEL CELL CONTROL ESS 3 AB CB	R4	IN	264
	36	NWS MNA CB	R4	IN	265
	35	HYD H2O BOILER 1 AC1 OA CB	R4	IN	266
	34	HYD H2O BOILER 2 AC2 OA CB	R4	IN	267
	33	HYD H2O BOILER 3 AC3 OA CB	R4	IN	268
	32	HSI SOURCE*	F6	TACAN	269
	31	HSI SOURCE*	F8	TACAN	270
	30	HSI SOURCE*	F6	MLS	271
	29	HSI SOURCE*	F8	MLS	272
	28	HSI SOURCE*	F6	1	273
	27	HSI SOURCE*	F8	1	274
26	HSI SOURCE*	F6	3	275	
25	HSI SOURCE*	F8	3	276	
24	AIR DATA TRANSOURCER RIGHT MNB CB	R4	IN	277	
23				278	
22	MASTER TIMING OSCILLATOR SW	L1	1	279	
21	MASTER TRAINING OSCILLATOR SW	L1	2	280	
20	FUEL CELL H2O VENT HTR A	O3	ON	281	
19	FUEL CELL H2O VENT HTR B	O3	ON	282	

* DUPLICATE DATA TRANSFERRED IN ADLC1. USE ADLC1 INPUTS PER ART NOLTING (2/5/75)

TABLE 3.2-4

ADLC2 INPUT DISCRETE LIST (5 OF 6) (Cont'd)

BUFFER PARAMETER		DESCRIPTION	PANEL	POSITION	6400-ADLC DISCRETE CHANNEL
VARIABLE NAME	BIT				
IDISIN2 (5) (CONTINUED)	18	SPEED BRAKE THRUST CONT SW *	L2	ON	283
	17	BODY FLAP SW*	L2	UP	284
	16	BODY FLAP SW*	L2	DOWN	285
	15	RDR ALTM *	F6	1	286
	14	AERO SURFACE AMP 4 SW	R4	ON	287
	13	AERO SURFACE AMP 3 SW	R4	ON	288
	12	NWS SW *	L2	DIRECT	289
	11				290
	10				291
	9				292
	8				293
	7				294
	6				295
	5				296
	4				297
	3				298
	2				299
	1				300

* DUPLICATE DATA TRANSFERRED IN ADLC1. USE ADLC1 INPUTS PER ART NOLTING (2/5/75)

TABLE 3.2-4

ADLC2 INPUT DISCRETE LIST (6 OF 6)

BUFFER PARAMETER		DESCRIPTION	PANEL	POSITION	6400-ADLC2 DISCRETE CHANNEL
VARIABLE NAME	BIT				
IDISIN2 (6)	60				301
	59	AIR DATA PROBE MOTORS AC1 OA - CB	R4	IN	302
	58	AIR DATA PROBE MOTOR AC2 OA - CB	R4	IN	303
	57	AIR DATA PROBE MOTOR AC3 OA - CB	R4	IN	304
	56				305
	55	LIMIT SET LIMIT SW	R12	UPPER	306
	54	LIMIT SET FUNC. SW	R12	READ	307
	53	APU LUBE OIL LINE 1 SW B	R12	AUTO	308
	52	APU LUBE OIL LINE 2 SW B	R12	AUTO	309
	51	APU LUBE OIL LINE 3 SW B	R12	AUTO	310
	50	C&W MEMORY	07	CLEAR	311
	49	C&W MEMORY	07	READ	312
	48	STEAM VENT HEATERS 1 SW	R12	ON	313
	47	STEAM VENT HEATERS 2 SW	R12	ON	314
	46	STEAM VENT HEATERS 3 SW	R12	ON	315
	45	C&W LIMIT SET PANEL	R12	SET	316
	44	C&W LAMP TEST	07	LEFT	317
	43	C&W MODE	07	ACK	318
	42	C&W LAMP TEST	07	RIGHT	319
	41	IMU 1 POWER	07	ON	320
	40	HYD/APU H2O BOILER HEATER 1	R12	AUTO	321
	39	HYD/APU H2O BOILER HEATER 2	R12	AUTO	322
	38	HYD/APU H2O BOILER HEATER 3	R12	AUTO	323
	37	HYD/APU H2O BOILER POWER 1	R12	ON	324
	36	HYD/APU H2O BOILER POWER 2	R12	ON	325
	35	HYD/APU H2O BOILER POWER 3	R12	ON	326
	34	APU LUBE OIL LINE 1 SW A	R12	AUTO	327
	33	APU LUBE OIL LINE 2 SW A	R12	AUTO	328
	32	APU LUBE OIL LINE 3 SW A	R12	AUTO	329
	31	CIRC PUMP 1 SW		MNA	330
	30	CIRC PUMP 2 SW	R12	MNB	331
	29	CIRC PUMP 3 SW	R12	MNC	332
	28	CIRC PUMP 1 SW	R12	MNB	333
	27	CIRC PUMP 2 SW	R12	MNC	334
	26	CIRC PUMP 3 SW	R12	MNA	335
	25	APU IND SEL	F8	QTY	336
	24	PARAM STATUS SWITCH	R12	TRIP	337
	23	PARAM STATUS SWITCH	R12	INHIBIT	338
	22	PARAM SW	R12	INHIBIT	339
	21	PARAM SW	R12	ENABLE	340
	20	APU TANK/FUEL LINE HEATERS 1 B SW	R12	AUTO	341
	19	APU TANK/FUEL LINE HEATERS 2 B SW	R12	AUTO	342
	18	APU TANK/FUEL LINE HEATERS 3 B SW	R12	AUTO	343
	17	APU TANK/FUEL LINE HEATERS 1 A SW	R12	AUTO	344
	16	APU TANK/FUEL LINE HEATERS 2 A SW	R12	AUTO	345
	15	APU TANK/FUEL LINE HEATERS 3 A SW	R12	AUTO	346
	14				247

* DUPLICATE DATA TRANSFERRED IN ADLC1. USE ADLC1 INPUTS PER ART NOLTING (2/5/75)

TABLE 3.2-4

ADLC2 INPUT DISCRETE LIST (6 OF 6) (Cont'd)

BUFFER PARAMETER		DESCRIPTION	PANEL	POSITION	6400-ADLC2 DISCRETE CHANNEL
VARIABLE NAME	BIT				
IDTSIN2 (6) (CONTINUED)	13	MEMORY SW	R12	READ	348
	12	MEMORY SW	R12	CLEAR	349
	11	MEMORY SW	R12	CLEAR	350
	10	MASTER ALARM SW	R12	IN	351
	9	APU GAS GEN/FUEL PUMP 1 SW A	R12	AUTO	352
	8	APU GAS GEN/FUEL PUMP 2 SW A	R12	AUTO	353
	7	APU GAS GEN/FUEL PUMP 3 SW A	R12	AUTO	354
	6				355
	5	APU IND SEL	F8	1	356
	4	APU IND SEL	F8	3	357
	3	APU GAS GEN/FUEL PUMP 1 SW B	R12	AUTO	358
	2	APU GAS GEN/FUEL PUMP 2 SW B	R12	AUTO	359
	1	APU GAS GEN/FUEL PUMP 3 SW B	R12	AUTO	360

* DUPLICATE DATA TRANSFERRED IN ADLC1. USE ADLC1 INPUTS PER ART NOLTING (2/5/75)

TABLE 3.2-5

ADLC2 OUTPUT DISCRETE LIST (1 OF 6)

BUFFER PARAMETER		DESCRIPTION	PANEL	POSITION	6400-ADLC2 DISCRETE CHANNEL
VARIABLE NAME	BIT				
IDISOT2 (1)	60	STATUS BOARD ROC0	R12	ON	1
	59	STATUS BOARD ROC1	R12	ON	2
	58	STATUS BOARD ROC2	R12	ON	3
	57	STATUS BOARD ROC3	R12	ON	4
	56	STATUS BOARD ROC4	R12	ON	5
	55	STATUS BOARD ROC5	R12	ON	6
	54	STATUS BOARD ROC6	R12	ON	7
	53	STATUS BOARD ROC7	R12	ON	8
	52	STATUS BOARD ROC8	R12	ON	9
	51	STATUS BOARD ROC9	R12	ON	10
	50	STATUS BOARD R1C0	R12	ON	11
	49	STATUS BOARD R1C1	R12	ON	12
	48	STATUS BOARD R1C2	R12	ON	13
	47	STATUS BOARD R1C3	R12	ON	14
	46	STATUS BOARD R1C4	R12	ON	15
	45	STATUS BOARD R1C5	R12	ON	16
	44	STATUS BOARD R1C6	R12	ON	17
	43	STATUS BOARD R1C7	R12	ON	18
	42	STATUS BOARD R1C8	R12	ON	19
	41	STATUS BOARD R1C9	R12	ON	20
	40	STATUS BOARD R2C0	R12	ON	21
	39	STATUS BOARD R2C1	R12	ON	22
	38	STATUS BOARD R2C2	R12	ON	23
	37	STATUS BOARD R2C3	R12	ON	24
	36	STATUS BOARD R2C4	R12	ON	25
	35	STATUS BOARD R2C5	R12	ON	26
	34	STATUS BOARD R2C6	R12	ON	27
	33	STATUS BOARD R2C7	R12	ON	28
	32	STATUS BOARD R2C8	R12	ON	29
	31	STATUS BOARD R2C9	R12	ON	30
	30	STATUS BOARD R3C0	R12	ON	31
	29	STATUS BOARD R3C1	R12	ON	32
	28	STATUS BOARD R3C2	R12	ON	33
	27	STATUS BOARD R3C3	R12	ON	34
	26	STATUS BOARD R3C4	R12	ON	35
	25	STATUS BOARD R3C5	R12	ON	36
	24	STATUS BOARD R3C6	R12	ON	37
	23	STATUS BOARD R3C7	R12	ON	38
	22	STATUS BOARD R3C8	R12	ON	39
	21	STATUS BOARD R3C9	R12	ON	40
	20	STATUS BOARD R4C0	R12	ON	41
	19	STATUS BOARD R4C1	R12	ON	42
	18	STATUS BOARD R4C2	R12	ON	43
	17	STATUS BOARD R4C3	R12	ON	44
	16	STATUS BOARD R4C4	R12	ON	45
	15	STATUS BOARD R4C5	R12	ON	46
	14	STATUS BOARD R4C6	R12	ON	47
	13	STATUS BOARD R4C7	R12	ON	48
	12	STATUS BOARD R4C8	R12	ON	49
	11	STATUS BOARD R4C9	R12	ON	50
	10	STATUS BOARD R5C0	R12	ON	51
	9	STATUS BOARD R5C1	R12	ON	52
	8	STATUS BOARD R5C2	R12	ON	53
	7	STATUS BOARD R5C3	R12	ON	54
	6	STATUS BOARD R5C4	R12	ON	55
	5	STATUS BOARD R5C5	R12	ON	56
	4	STATUS BOARD R5C6	R12	ON	57
	3	STATUS BOARD R5C7	R12	ON	58
	2	STATUS BOARD R5C8	R12	ON	59
	1	STATUS BOARD R5C9	R12	ON	60

TABLE 3.2-5

ADLC2 OUTPUT DISCRETE LIST (2 OF 6)

BUFFER PARAMETER		DESCRIPTION	PANEL	POSITION	6400-ADLC2 DISCRETE CHANNEL
VARIABLE NAME	BIT				
IDISOT2 (2)	60	STATUS BOARD R6C0	R12	ON	61
	59	STATUS BOARD R6C1	R12	ON	62
	58	STATUS BOARD R6C2	R12	ON	63
	57	STATUS BOARD R6C3	R12	ON	64
	56	STATUS BOARD R6C4	R12	ON	65
	55	STATUS BOARD R6C5	R12	ON	66
	54	STATUS BOARD R6C6	R12	ON	67
	53	STATUS BOARD R6C7	R12	ON	68
	52	STATUS BOARD R6C8	R12	ON	69
	51	STATUS BOARD R6C9	R12	ON	70
	50	STATUS BOARD R7C0	R12	ON	71
	49	STATUS BOARD R7C1	R12	ON	72
	48	STATUS BOARD R7C2	R12	ON	73
	47	STATUS BOARD R7C3	R12	ON	74
	46	STATUS BOARD R7C4	R12	ON	75
	45	STATUS BOARD R7C5	R12	ON	76
	44	STATUS BOARD R7C6	R12	ON	77
	43	STATUS BOARD R7C7	R12	ON	78
	42	STATUS BOARD R7C8	R12	ON	79
	41	STATUS BOARD R7C9	R12	ON	80
	40	STATUS BOARD R8C0	R12	ON	81
	39	STATUS BOARD R8C1	R12	ON	82
	38	STATUS BOARD R8C2	R12	ON	83
	37	STATUS BOARD R8C3	R12	ON	84
	36	STATUS BOARD R8C4	R12	ON	85
	35	STATUS BOARD R8C5	R12	ON	86
	34	STATUS BOARD R8C6	R12	ON	87
	33	STATUS BOARD R8C7	R12	ON	88
	32	STATUS BOARD R8C8	R12	ON	89
	31	STATUS BOARD R8C9	R12	ON	90
	30	STATUS BOARD R9C0	R12	ON	91
	29	STATUS BOARD R9C1	R12	ON	92
	28	STATUS BOARD R9C2	R12	ON	93
	27	STATUS BOARD R9C3	R12	ON	94
	26	STATUS BOARD R9C4	R12	ON	95
	25	STATUS BOARD R9C5	R12	ON	96
	24	STATUS BOARD R9C6	R12	ON	97
23	STATUS BOARD R9C7	R12	ON	98	
22	STATUS BOARD R9C8	R12	ON	99	
21	STATUS BOARD R9C9	R12	ON	100	
20	STATUS BOARD R10C0	R12	ON	101	
19	STATUS BOARD R10C1	R12	ON	102	
18	STATUS BOARD R10C2	R12	ON	103	
17	STATUS BOARD R10C3	R12	ON	104	
16	STATUS BOARD R10C4	R12	ON	105	
15	C/W H2 PRESS LIGHT	F7	ON	106	
14	C/W O2 PRESS LIGHT	F7	ON	107	
13	C/W FUEL CELL 1 LIGHT	F7	ON	108	
12	C/W FUEL CELL 2 LIGHT	F7	ON	109	
11	C/W FUEL CELL 3 LIGHT	F7	ON	110	
10	C/W CABIN ATM LIGHT	F7	ON	111	
9				112	
8	C/W MAIN BUS UNDER VOLT LIGHT	F7	ON	113	
7	C/W AC VOLTAGE LIGHT	F7	ON	114	
6	C/W OVERLOAD LIGHT	F7	ON	115	
5				116	
4	C/W CABIN FLOW LIGHT	F7	ON	117	
3	C/W IMU LIGHT	F7	ON	118	
2				119	
1				120	

TABLE 3.2-5

ADLC2 OUTPUT DISCRETE LIST (3 OF 6)

BUFFER PARAMETER		DESCRIPTION	PANEL	POSITION	6400-ADLC2 DISCRETE CHANNEL
VARIABLE NAME	BIT				
IDISOT2 (3)	60	C/W GYRO/ACCEL LIGHT	F7	ON	121
	59		F7	ON	122
	58	C/W NAV SENSOR LIGHT			123
	57				124
	56				125
	55				126
	54	C/W LEFT RHC LIGHT	F7	ON	127
	53	C/W RIGHT RHC LIGHT	F7	ON	128
	52				129
	51				130
	50				131
	49	C/W COMPUTER LIGHT	F7	ON	132
	48	C/W CONTROL SYST. SATURATION LIGHT	F7	ON	133
	47				134
	46				135
	45				136
	44	C/W LIGHT	F7	ON	137
	43	C/W FLIGHT CONT CH LIGHT	F7	ON	138
	42				139
	41				140
	40	C/W BK UP C/W	F7	ON	141
	39	C/W APU TEMP LIGHT	F7	ON	142
	38	C/W APU OVER-SPEED LIGHT	F7	ON	143
	37	C/W APU UNDER SPEED LIGHT	F7	ON	144
	36	C/W HYD PRESS LIGHT	F7	ON	145
	35	SM ALERT LIGHT	F7	ON	146
	34				147
	33				148
	32				149
	31				150
	30				151
	29				152
28				153	
27				154	
26				155	
25				156	
24				157	
23				158	
22				159	
21				160	
20				161	
19				162	
18				163	
17				164	
16				165	
15				166	
14				167	
13				168	
12				169	
11				170	
10				171	
9				172	
8				173	
7				174	
6				175	
5				176	
4				177	
3				178	
2				179	
1				180	

TABLE 3.2-5

ADLC2 OUTPUT DISCRETE LIST (4 OF 6)

BUFFER PARAMETER		DESCRIPTION	PANEL	POSITION	6400-ADLC2 DISCRETE CHANNEL	
VARIABLE NAME	BIT					
IDISOT2 (4)	60	STATUS BOARD R10C5	R12	ON	181	
	59	STATUS BOARD R10C6	R12	ON	182	
	58	STATUS BOARD R10C7	R12	ON	183	
	57	STATUS BOARD R10C8	R12	ON	184	
	56	STATUS BOARD R10C9	R12	ON	185	
	55	STATUS BOARD R11C0	R12	ON	186	
	54	STATUS BOARD R11C1	R12	ON	187	
	53	STATUS BOARD R11C2	R12	ON	188	
	52	STATUS BOARD R11C3	R12	ON	189	
	51	STATUS BOARD R11C4	R12	ON	190	
	50	STATUS BOARD R11C5	R12	ON	191	
	49	STATUS BOARD R11C6	R12	ON	192	
	48	STATUS BOARD R11C7	R12	ON	193	
	47	STATUS BOARD R11C8	R12	ON	194	
	46	STATUS BOARD R11C9	R12	ON	195	
	45					196
	44					197
	43					198
	42					199
	41					200
	40					201
	39					202
	38					203
	37					204
36					205	
35					206	
34					207	
33					208	
32					209	
31					210	
30					211	
29					212	
28					213	
27					214	
26					215	
25					216	
24					217	
23					218	
22					219	
21					220	
20					221	
19					222	
18					223	
17					224	
16					225	
15					226	
14					227	
13					228	
12					229	
11					230	
10					231	
9					232	
8					233	
7					234	
6					235	
5					236	
4					237	
3					238	
2					239	
1					240	

ORIGINAL PAGE IS
OF POOR QUALITY

TABLE 3.2-5

ADLC2 OUTPUT DISCRETE LIST (5 OF 6)

BUFFER PARAMETER		DESCRIPTION	PANEL	POSITION	6400-ADLC2 DISCRETE CHANNEL			
VARIABLE NAME	BIT							
IDISOT2 (5)	60	SM ALARM	-	ON	241			
	59				242			
	58				243			
	57				244			
	56				245			
	55				246			
	54				247			
	53				248			
	52				249			
	51				250			
	50				251			
	49				252			
	48				253			
	47				254			
	46				255			
	45				256			
	44				257			
	43				258			
	42				259			
	41				260			
	40				261			
	39				262			
	38				263			
	37				264			
	36				265			
	35				266			
	34				C&W 400 CPS ALARM	-	ON	267
	33							268
	32							269
	31							270
	30							271
	29							272
28				273				
27				274				
26				275				
25				276				
24	C&W 1000 CPS ALARM	-	ON	277				
23				278				
22				279				
21				280				
20				281				
19				282				
18				283				
17				284				
16	MASTER ALARM LIGHT	R12	ON	285				
15				286				
14				287				
13				288				
12				289				
11				290				
10				291				
9	LEFT PROBE DEPLOYED TALKBACK	C3	GRAY	292				
8	RIGHT PROBE DEPLOYED TALKBACK	C3	GRAY	293				
7	LEFT PROBE STOWED TALKBACK	C3	GRAY	294				
6	RIGHT PROBE STOWED TALKBACK	C3	GRAY	295				
5	HPG TANK VLV H2 TK1 TALKBACK	R2	GRAY	296				
4	HPG TANK VLV H2 TK2 TALKBACK	R2	GRAY	297				
3	HPG TANK VLV O2 TK1 TALKBACK	R2	GRAY	298				
2	HPG TANK VLV O2 TK2 TALKBACK	R2	GRAY	299				
1	HPG MANIF. ISOL/CRSFD H2 TK1 TBK	R2	GRAY	300				

TABLE 3.2-5

ADLC2 OUTPUT DISCRETE LIST (6 OF 6)

BUFFER PARAMETER		DESCRIPTION	PANEL	POSITION	6400-ADLC DISCRETE CHANNEL	
VARIABLE NAME	BIT					
IDISOT2 (6)	60	WPG MANIF. ISOL/CRSFD H2 TK2 TBK	R2	GRAY	301	
	59	WGP MANIF. ISOL/CRSFD 02 TK1 TBK	R2	GRAY	302	
	58	WPG MANIF. ISOL/CRSFD 02 TK2 TBK	R2	GRAY	303	
	57	FUEL CELL REACTANTS 1H2 TBK	R2	GRAY	304	
	56	FUEL CELL REACTANTS 102 TBK	R2	GRAY	305	
	55	FUEL CELL REACTANTS 2H2 TBK	R2	GRAY	306	
	54	FUEL CELL REACTANTS 202 TBK	R2	GRAY	307	
	53	FUEL CELL REACTANTS 3H2 TBK	R2	GRAY	308	
	52	FUEL CELL REACTANTS 302 TBK	R2	GRAY	309	
	51				310	
	50				311	
	49				312	
	48				313	
	47				314	
	46				315	
	45				316	
	44				317	
	43				318	
	42		FUEL TANK VALVE 1 TBK	R2	GRAY	319
	41		FUEL TANK VALVE 2 TBK	R2	GRAY	320
	40		FUEL TANK VALVE 3 TBK	R2	GRAY	321
	39		HYD READY FOR APU START 1 TBK	R2	GRAY	322
	38		HYD READY FOR APU START 2 TBK	R2	GRAY	323
	37		HYD READY FOR APU START 3 TBK	R2	GRAY	324
	36		COOLANT PUMP SP 1 TBK	R2	GRAY	325
	35		COOLANT PUMP SP 2 TBK	R2	GRAY	326
	34		COOLANT PUMP SP 3 TBK	R2	GRAY	327
	33				328	
	32				329	
	31		NWS FAIL LIGHT	F3	ON	330
	30		APU READY FOR START 1 TBK	R2	GRAY	331
	29		APU READY FOR START 2 TBK	R2	GRAY	332
	28		APU READY FOR START 3 TBK	R2	GRAY	333
	27				334	
	26				335	
	25		MASTER ALARM LIGHT	F2	ON	336
	24		DC TIE BUS MNA TBK	R1	GRAY	337
	23		DC TIE BUS MNB TBK	R1	GRAY	338
	22		DC TIE BUS MNC TBK	R1	GRAY	339
	21		ANTI SKID FAIL LIGHT	F3	ON	340
	20				341	
	19		MAIN DC BUS A TBK	R1	GRAY	342
18		MAIN DC BUS B TBK	R1	GRAY	343	
17		MAIN DC BUS C TBK	R1	GRAY	344	
16		AC BUS 1 TBK	R1	GRAY	345	
15		AC BUS 2 TBK	R1	GRAY	346	
14		AC BUS 3 TBK	R1	GRAY	347	
13				348		
12				349		
11		MASTER ALARM LIGHT	F4	ON	350	
10				351		

TABLE 3.2-5

ADLC2 OUTPUT DISCRETE LIST (6 OF 6) (Cont'd)

BUFFER PARAMETER		DESCRIPTION	PANEL	POSITION	6400-ADLC1 DISCRETE CHANNEL
VARIABLE NAME	BIT				
IDISOT2 (6) (CONTINUED)	9	FUEL CELL READY 1 TBK	02	GRAY	352
	8	FUEL CELL READY 2 TBK	02	GRAY	353
	7	FUEL CELL READY 3 TBK	02	GRAY	354
	6				355
	5				356
	4	MASTER ALARM LIGHT	R12	ON	357
	3				358
	2				359
	1				360

TABLE 3.2-6

ADLC1 OUTPUT DISCRETE LIST (1 OF 6)

BUFFER PARAMETER		DESCRIPTION	PANEL	POSITION	6400-ADLC1 DISCRETE CHANNEL
VARIABLE NAME	BIT				
IDISOT2 (1)	60				1
	59				2
	58				3
	57				4
	56				5
	55				6
	54				7
	53				8
	52				9
	51				10
	50				11
	49				12
	48				13
	47				14
	46				15
	45				16
	44				17
	43				18
	42				19
	41				20
	40				21
	39				22
	38				23
	37				24
	36				25
	35				26
	34				27
	33				28
	32				29
	31				30
	30				31
	29				32
	28				33
	27				34
	26				35
	25				36
	24				37
	23				38
	22				39
	21				40
	20				41
	19				42
	18				43
	17				44
	16				45
	15				46
	14				47
	13				48
	12				49
	11				50
	10				51
	9				52
	8				53
	7				54
	6				55
	5				56
	4				57
	3				58
	2				59
	1				60

TABLE 3,2-6

ADLC2 OUTPUT DISCRETE LIST (2 OF 6)

BUFFER PARAMETER		DESCRIPTION	PANEL	POSITION	6400-ADLC1 DISCRETE CHANNEL
VARIABLE NAME	BIT				
IDISOT2 (2)	60				61
	59				62
	58				63
	57				64
	56				65
	55				66
	54				67
	53				68
	52				69
	51				70
	50				71
	49				72
	48				73
	47				74
	46				75
	45				76
	44				77
	43				78
	42				79
	41				80
40				81	
39				82	
38				83	
37				84	
36				85	
35				86	
34				87	
33				88	
32				89	
31				90	
30				91	
29				92	
28				93	
27				94	
26				95	
25				96	
24				97	
23				98	
22				99	
21				100	
20				101	
19				102	
18				103	
17				104	
16				105	
15				106	
14				107	
13				108	
12				109	
11				110	
10				111	
9				112	
8				113	
7				114	
6				115	
5				116	
4				117	
3				118	
2				119	
1				120	

TABLE 3.2-6

ADLC1 OUTPUT DISCRETE LIST (3 OF 6)

BUFFER PARAMETER		DESCRIPTION	PANEL	POSITION	6400-ADLC1 DISCRETE CHANNEL
VARIABLE NAME	BIT				
IDISOT2 (3)	60				121
	59				122
	58				123
	57				124
	56				125
	55				126
	54				127
	53				128
	52				129
	51				130
	50				131
	49				132
	48				133
	47				134
	46				135
	45				136
	44				137
	43				138
	42				139
	41				140
	40				141
	39				142
	38				143
	37				144
	36				145
	35				146
	34				147
	33				148
	32				149
	31				150
	30				151
	29				152
28				153	
27				154	
26				155	
25				156	
24				157	
23				158	
22				159	
21				160	
20				161	
19				162	
18				163	
17				164	
16				165	
15				166	
14				167	
13				168	
12				169	
11				170	
10				171	
9				172	
8				173	
7				174	
6				175	
5				176	
4				177	
3				178	
2				179	
1				180	

TABLE 3.2-6
ADLC1 OUTPUT DISCRETE LIST (4 OF 6)

BUFFER PARAMETER VARIABLE NAME	BIT	DESCRIPTION	PANEL	POSITION	6400-ADLC1 DISCRETE CHANNEL
IDISOT2 (4)	60				181
	59				182
	58				183
	57				184
	56				185
	55				186
	54				187
	53				188
	52				189
	51				190
	50				191
	49				192
	48				193
	47				194
	46				195
	45				196
	44				197
	43				198
	42				199
	41				200
	40				201
	39				202
	38				203
	37				204
	36				205
	35				206
	34				207
	33				208
	32				209
	31				210
	30				211
	29				212
	28				213
	27				214
	26				215
	25				216
	24				217
	23				218
	22				219
	21				220
	20				221
	19				222
	18				223
	17				224
	16				225
	15				226
	14				227
	13				228
	12				229
	11				230
	10				231
	9				232
	8				233
	7				234
	6				235
	5				236
	4				237
	3				238
	2				239
	1				240

TABLE 3.2-6

ADLC1 OUTPUT DISCRETE LIST (5 OF 6)

BUFFER PARAMETER		DESCRIPTION	PANEL	POSITION	6400-ADLC1 DISCRETE CHANNEL
VARIABLE NAME	BIT				
~ IDISOT2 (5)	60				241
	59				242
	58				243
	57				244
	56				245
	55				246
	54				247
	53				248
	52				249
	51				250
	50				251
	49				252
	48				253
	47				254
	46				255
	45				256
	44				257
	43				258
	42				259
	41				260
	40				261
	39				262
	38				263
	37				264
	36				265
	35				266
	34				267
	33				268
	32				269
	31				270
	30				271
29				272	
28				273	
27				274	
26				275	
25				276	
24				277	
23				278	
22				279	
21				280	
20				281	
19				282	
18				283	
17				284	
16				285	
15				286	
14		LANDING GEAR DOWN LIGHT	F6	ON	287
13		LANDING GEAR ARM LIGHT	F6	ON	288
12		LANDING GEAR LEFT TBK	F6	UP	289
11		LANDING GEAR LEFT TBK	F6	DOWN	290
10		LANDING GEAR RIGHT TBK	F6	UP	291
9		LANDING GEAR RIGHT TBK	F6	DOWN	292
8		LANDING GEAR NOSE TBK	F6	UP	293
7		LANDING GEAR NOSE TBK	F6	DOWN	294
6		LANDING GEAR ARM LT	F8	ON	295
5		LANDING GEAR DOWN LT	F8	ON	296
4		BFC ENGAGE LT		ON	297
3		BODY FLAP AUTO LIGHT		ON	298
2		SPEED BRAKE AUTO LIGHT	F2	ON	299
1		SPEED BRAKE AUTO LIGHT	F4	ON	300

TABLE 3.2-6

ADLC1 OUTPUT DISCRETE LIST (6 OF 6)

BUFFER PARAMETER		DESCRIPTION	PANEL	POSITION	6400-ADLC1 DISCRETE CHANNEL
VARIABLE NAME	BIT				
IDISOT2 (6)	60	ROLL/YAW DIR LIGHT		ON	301
	59	ROLL/YAW CSS LIGHT		ON	302
	58	ROLL/YAW AUTO LIGHT		ON	303
	57	PITCH DIR LIGHT		ON	304
	56	PITCH CSS LIGHT		ON	305
	55	PITCH AUTO LIGHT		ON	306
	54	EVENT SEQ 1 LIGHT		ON	307
	53	EVENT SEQ 2 LIGHT		ON	308
	52	EVENT SEQ 3 LIGHT		ON	309
	51	EVENT SEQ 4 LIGHT		ON	310
	50	EVENT SEQ 5 LIGHT		ON	311
	49	LANDING GEAR LEFT TBK	F8	UP	312
	48	LANDING GEAR LEFT TBK	F8	DOWN	313
	47	LANDING GEAR RIGHT TBK	F8	UP	314
	46	LANDING GEAR RIGHT TBK	F8	DOWN	315
	45	LANDING GEAR NOSE TBK	F8	UP	316
	44	LANDING GEAR NOSE TBK		DOWN	317
	43				318
	42	BODY FLAP MAN LIGHT		ON	319
	41	SPEED BRAKE MAN LIGHT	F2	ON	320
	40				321
	39				322
	38				323
	37				324
	36				325
	35				326
	34				327
	33				328
	32				329
	31	SPEED BRAKE MAN LIGHT	F4	ON	330
	30				331
	29				332
	28				333
	27				334
	26				335
	25				336
	24				337
	23				338
	22				339
	21				340
20				341	
19				342	
18				343	
17				344	
16				345	
15				346	
14				347	
13				348	
12				349	
11				350	
10				351	
9				352	
8				353	
7				354	
6				355	
5				356	
4				357	
3				358	
2				359	
1				360	

TABLE 3.2-7. DEFINITION OF PERFORMANCE DATA TRANSFER FROM SPS

FRAME #	DATA BLOCK RATE	LOCATION #	PARAMETER NAME	PARAMETER DEFINITION	UNITS
1	20/SEC 5/SEC #1	1	TIME	GROUND ELAPSED TIME	SEC
		2	CR	CROSS RANGE	NM
		3	DR	DOWN RANGE	NM
		4	R	RANGE	FT
		5	QDOT	HEATING RATE	BTU/FT ² -SEC
		6	HDOT	ALTITUDE RATE	FPS
		7	VRÉL	RELATIVE VELOCITY	FPS
		8	G	G LOAD	G
	1/SEC #1	9	GX	ACCELERATION IN X-AXIS	G
		10	GZ	ACCELERATION IN Z-AXIS	G
		11	HDTG	COMMANDED ALTITUDE RATE	FPS
		12	ICCOORD	COORDINATE FLAG	--
		13		NONE	--
		14	GMODE	GUIDANCE MODE CHANGES	--
		15		NONE	--
		16	IFRAME	FRAME COUNTER	
2	20/SEC 5/SEC	1	TIME	GROUND ELAPSED TIME	SEC
		2	BANK	BANK ANGLE	DEG
		3	ALPHA	ANGLE OF ATTACK	DEG
		4	LATITUDE	VEHICLE GROUND TRACK LATITUDE	DEG
		5	LONGITUDE	VEHICLE GROUND TRACK LONGITUDE	DEG
		6	DELTAL	LOCALIZER ERROR	DOTS
		7	DELTAG	GLIDESLOPE ERROR	DOTS
		8	ELEV	ELEVON DEFLECTION	DEG
	1/SEC #2	9	DEFLEC	BODY FLAP DEFLECTION	DEG
		10	ALT	ALTITUDE	FT
		11	BCMD	COMMANDED BANK ANGLE	DEG
		12	MACHNO	MACH NUMBER	
		13		X	FPS
		14		Y MANEUVER VELOCITY COMPONENTS	FPS
		15		Z	FPS
		16	IFRAME	FRAME COUNTER	SEC
3	20/SEC 5/SEC #3	1	TIME	GROUND ELAPSED TIME	SEC
		2		MAIN ENGINE GIMBAL ANGLE	DEG
		3		MAIN ENGINE GIMBAL ANGLE	DEG
		4		MAIN ENGINE GIMBAL ANGLE	DEG
		5		MAIN ENGINE GIMBAL ANGLE	DEG
		6		MAIN ENGINE GIMBAL ANGLE	DEG
		7		MAIN ENGINE GIMBAL ANGLE	DEG
		8	PBODY	ROLL RATE	DEG/SEC
	1/SEC #3	9	QBODY	PITCH RATE	DEG/SEC
		10	RBODY	YAW RATE	DEG/SEC
		11	GCMD	COMMANDED G LOAD	G
		12	VIAS	INDICATED AIRSPEED	KNOTS
		13		NONE	
		14		NONE	
		15		NONE	
		16	IFRAME	FRAME COUNTER	

TABLE 3.2-7 DEFINITION OF PERFORMANCE DATA TRANSFER FROM SPS (continued)

FRAME #	DATA BLOCK RATE	LOCATION #	PARAMETER NAME	PARAMETER DEFINITION	UNITS
4	20/SEC 5/SEC #4	1	TIME	GROUND ELAPSED TIME	SEC
		2	THETAH	LOCAL HORIZONTAL ATTITUDE θ_{LH}	DEG
		3	PHIH	LOCAL HORIZONTAL ATTITUDE ϕ_{LH}	DEG
		4	PSIH	LOCAL HORIZONTAL ATTITUDE ψ_{LH}	DEG
		5	THETA I	INERTIAL ATTITUDE θ_I	DEG
		6	PHI I	INERTIAL ATTITUDE ϕ_I	DEG
		7	PHI I	INERTIAL ATTITUDE ψ_I	DEG
		8			COMMANDED ATTITUDE θ_C
	1/SEC #4	9		COMMANDED ATTITUDE ϕ_C	DEG
		10		COMMANDED ATTITUDE ψ_C	DEG
		11	RPOT	RANGE POTENTIAL	NM
		12	TLD	TOTAL LIFT TO DRAG RATIO	-
		13	RALT	ONBOARD RADAR ALTITUDE	FT
		14	GS	GROUND SPEED	FPS
		15		NONE	
		16	IFRAME	FRAME COUNTER	
5	20/SEC 5/SEC #1 1/SEC #5	1	TIME	GROUND ELAPSED TIME	SEC
		2-12		SAME AS 5/SEC PARAMETERS OF FRAME 1	
		13		NONE	
		14		NONE	
	15		NONE		
20/SEC	16	IFRAME	FRAME COUNTER		
6	20/SEC 5/SEC #2 1/SEC #6	1	TIME	GROUND ELAPSED TIME	SEC
		2-12		SAME AS 5/SEC PARAMETERS OF FRAME 2	
		13			DEG
		14		IMU ERRORS	DEG
	20/SEC	15			DEG
	16	IFRAME	FRAME COUNTER		
7	20/SEC 5/SEC #3 1/SEC #7	1	TIME	GROUND ELAPSED TIME	SEC
		2-12		SAME AS 5/SEC PARAMETERS OF FRAME 3	
		13		ALTITUDE AT VEHICLE APOGEE	NM
		14		ALTITUDE AT VEHICLE PERIGEE	NM
	20/SEC	15		NONE	
	16	IFRAME	FRAME COUNTER		
8	20/SEC 5/SEC #4 1/SEC #8	1	TIME	GROUND ELAPSED TIME	SEC
		2-12		SAME AS 5/SEC PARAMETERS OF FRAME 4	
		13			FT
		14		ONBOARD POSITION ERROR	FT
	20/SEC	15			FT
	16	IFRAME	FRAME COUNTER	FT	
9	20/SEC 5/SEC #1 1/SEC #9	1	TIME	GROUND ELAPSED TIME	SEC
		2-12		SAME AS 5/SEC PARAMETERS OF FRAME 1	
		13			FPS
		14		ONBOARD VELOCITY ERROR	FPS
	20/SEC	15			FPS
	16	IFRAME	FRAME COUNTER		

TABLE 3.2-7 DEFINITION OF PERFORMANCE DATA TRANSFER FROM SPS (continued)

FRAME #	DATA BLOCK RATE	LOCATION #	PARAMETER NAME	PARAMETER DEFINITION	UNITS
10	20/SEC 5/SEC #2 1/SEC #10	1	TIME	GROUND ELAPSED TIME	SEC
		2-12	SAME AS 5/SEC PARAMETERS OF FRAME 2		
		13		HORIZON SENSOR 1 ANGLES	DEG
		14			DEG
	15		NONE		
	20/SEC	16	IFRAME	FRAME COUNTER	
11	20/SEC 5/SEC #3 1/SEC #11	1	TIME	GROUND ELAPSED TIME	SEC
		2-12	SAME AS 5/SEC PARAMETERS OF FRAME 3		
		13		HORIZON SENSOR 2 ANGLES	DEG
		14			DEG
	15		NONE		
	20/SEC	16	IFRAME	FRAME COUNTER	
12	20/SEC 5/SEC #4 1/SEC #12	1	TIME	GROUND ELAPSED TIME	SEC
		2-12	SAME AS 5/SEC PARAMETERS OF FRAME 4		
		13		INCLINATION ANGLE	DEG
		14	GAMMA	FLIGHT PATH ANGLE	DEG
	15		NONE		
	20/SEC	16	IFRAME	FRAME COUNTER	
13	20/SEC 5/SEC #1 1/SEC #13	1	TIME	GROUND ELAPSED TIME	SEC
		2-12	SAME AS 5/SEC PARAMETERS OF FRAME 1		
		13	HEAD	HSI MAGNETIC HEADING	DEG
		14	DEV	HSI DEVIATION	DOTS
	15	RI	HSI DISTANCE	NM	
	20/SEC	16	IFRAME	FRAME COUNTER	
14	20/SEC 5/SEC #2 1/SEC #14	1	TIME	GROUND ELAPSED TIME	SEC
		2-12	SAME AS 5/SEC PARAMETERS OF FRAME 2		
		13	X	VEHICLE POSITION VECTOR	FT
		14	Y		FT
	15	Z	FT		
	20/SEC	16	IFRAME	FRAME COUNTER	
15	20/SEC 5/SEC #3 1/SEC #15	1	TIME	GROUND ELAPSED TIME	SEC
		2-12	SAME AS 5/SEC PARAMETERS OF FRAME 3		
		13	XDT	VELOCITY VECTOR	FPS
		14	YDT		FPS
	15	ZDT	FPS		
	20/SEC	16	IFRAME	FRAME COUNTER	
16	20/SEC 5/SEC #4 1/SEC #16	1	TIME	GROUND ELAPSED TIME	SEC
		2-12	SAME AS 5/SEC PARAMETERS OF FRAME 4		
		13		STAR IDENTIFIER	-
		14		AZIMUTH ANGLE TO STAR	DEG
	15		ELEVATION ANGLE TO STAR	DEG	
	20/SEC	16	IFRAME	FRAME COUNTER	
17	20/SEC 5/SEC #1 1/SEC #17	1	TIME	GROUND ELAPSED TIME	SEC
		2-12	SAME AS 5/SEC PARAMETERS OF FRAME 1		
		13	BALT	BARO ALTIMETER READING	FT
		14		BAROMETRIC PRESSURE	IN. HG.
	15		HORIZON SENSOR ERROR	DEG	
	20/SEC	16	IFRAME	FRAME COUNTER	

TABLE 3.2-7 DEFINITION OF PERFORMANCE DATA TRANSFER FROM SPS (continued)

FRAME #	DATA BLOCK RATE	LOCATION #	PARAMETER NAME	PARAMETER DEFINITION	UNITS	
18	20/SEC	1	TIME	GROUND ELAPSED TIME	SEC	
	5/SEC #2	2-12	SAME AS 5/SEC	PARAMETERS OF FRAME 2		
	1/SEC #18	13				DEG
		14			HORIZON SENSOR ERRORS	DEG
		15				DEG
20/SEC	16	IFRAME	FRAME COUNTER			
19	20/SEC	1	TIME	GROUND ELAPSED TIME	SEC	
	5/SEC #3	2-12	SAME AS 5/SEC	PARAMETERS OF FRAME 3		
	1/SEC #19	13	RCS	RCS PROPELLANT USED	LBS	
		14		OMS PROPELLANT USED	LBS	
		15		ORB PROPELLANT REMAINING	LBS	
20/SEC	16	IFRAME	FRAME COUNTER			
20	20/SEC	1	TIME	GROUND ELAPSED TIME	SEC	
	5/SEC #4	2-12	SAME AS 5/SEC	PARAMETERS OF FRAME 4		
	1/SEC #20	13		STDN STATION I.O. NUMBER	-	
		14		STDN COVERAGE AOS TIME	SEC	
		15		STDN COVERAGE LOS TIME	SEC	
20/SEC	16	IFRAME	FRAME COUNTER			

3.3 PPP Software Description

The PPP is an all digital computer program which uses state-of-the-art programming techniques utilizing standard Fortran IV language except for several subroutines which are coded in Compass.

PPP is required, due to interface constraints with the SPS and its functional requirements, to execute within 47777_8 ($20K_{10}$) words of core. The program design makes use of overlays where practical in order to stay within this core limitation. Those requirements which must be satisfied continually have been assigned to the main overlay. Those requirements which are satisfied on an as-requested basis are assigned to primary or secondary overlays.

The design of the PGP incorporates four basic features:

- 1) Modular design to simplify identification of necessary program structures,
- 2) Real-time processing to provide the interface between the PPP and the SPS,
- 3) Multi-computational-loops to ensure integrity of required data processing, and
- 4) Data driven design to allow user definition of critical parameters which define the format of the procedures data and evaluation data.

The PPP has been designed to operate in real-time and non-real time, and to accept user inputs via punch cards or interactive terminals. The following sections of this report present a summary discussion of the PPP software. Section 3.3.1 summarizes the top-level design and program flow of PPP while Section 3.3.2 discusses the unique details of the PPP design.

3.3.1 PPP Design and Program Flow

PPP Module Design and Subroutine Definition

The design of the Procedures and Performance Program has been accomplished by assigning the requirements specified in Reference 4 and Reference 5 to nineteen software modules, and by further assignment of the requirements to subroutine and subroutine entry points within each module. Reference 6 and Reference 7 presents the details of the PPP top-level design. Functional flow diagrams, and requirements traceability matrices, presented in these references, identify the specific requirements satisfied by the different sub-routines within a module.

The nineteen PPP modules are:

1. Initialization (INITIAL),
2. Sequence Control (SEQCON),
3. Real-time Interface (RTFACE),
4. Input/Output (INOUT),
5. Procedures Processor (PROCPR),
6. Difference Procedures Processor (DIFPPR),
7. Performance Processor (PERFPR),
8. Performance Evaluation Processor (EVALPR),
9. Procedures Formatter (PROCFM),
10. Difference Procedures Formatter (DIFPFM),
11. Performance Data Formatter (PERFFM),
12. Performance Evaluation Formatter (EVALFM),
13. Training Formatter (TRAINFM),
14. Post-Run (POSTRUN),
15. Real-Time Input/Output (RTIO),

16. Graphics Formatter Module
17. GDP to PPP Transfer Processor (GDPPGP)
18. PPP Support Subroutines (SUPSUB)
19. PPP Support Function Routine (SUPFUNC).

A functional description of each element of the PPP software is presented in Table 3.3-1.

TABLE 3.3-1 PPP Software Functions Description

MODULE	PROGRAM	SUBROUTINE	ENTRY POINT	DESCRIPTION
INITIAL	INITIAL	SPSLOAD INERROR	INERRS	INITIALIZATION MODULE MAIN INITIALIZATION ROUTINE PROCESS INITIAL SPS LOAD INITIALIZATION ERROR DISPLAY SPSLOAD ERRORS
		FMTS	INEFMT INEREA INRECEP	FORMAT DESCRIPTOR ERRORS READER ERRORS RECORD ERRORS
		FMTSRTN		CONSTRUCT ALPHANUMERIC FORMAT DESCRIPTOR
		FMTCMDS	FMTSRTN	PROCESS COMMANDS FOR FMTS
			FMTCMDE	ERROR PROCESSING FOR FMTS COMMANDS
	REFDATA RECORD READIN			SELECT REFERENCE RUN DATA CONSTRUCT RUN IDENTIFIER DATA BASE INPUT DRIVER
	INDTREE HARD	READER		PROCESS DATA BASE INPUT TUTORIAL INITIALIZATION DISPLAY HARDCOPY REQUEST PROCESSOR
		HARDKMD HRDSPLY		PROCESS HARDCOPY COMMANDS PROCESS HARDCOPY DISPLAYS
	PLOT GRAFMT			CALCOMP PLOT REQUEST PROCESSOR CONSTRUCT GRAPHICS FORMAT DESCRIPTOR
		COMP		SET COMPLETE STATUS FOR USER INPUT
		HOLPAK		UTILITY SOFTWARE-PACK HOLLERITH WORD
		NUMSPLT		UTILITY SOFTWARE-DECODE SPLIT NO. (2/4)
		NUMPAK		UTILITY SOFTWARE-PACK NUMBER IN WORD
		MASKSET		UTILITY SOFTWARE-SET MASK CODES FOR IGS
		LPCMD SCALE		PROCESS LIGHT PEN COMMANDS DEVELOP SCALE DATA
	LOG REQUEST			RECORD IDENTIFIER LOG PROCESS USER REQUEST OF REAL-TIME INITIATION
	FMTSD1	RTINTAL		INITIALIZE PPP REAL TIME FORMAT IDENTIFICATION AND TYPE DATA
	FMTSD2 FMTSD3 FMTSD4 FMTSD5			DEFINITION OF COLUMINAR DATA DEFINITION OF TIME INTERNAL DEFINITION OF FIXED FORMAT DATA DEFINITION OF DATA EVALUATION DISPLAY
	FMTSD6			DEFINITION OF TRAINING FORMAT

TABLE 3.3-1 PPP Software Functions Description (Cont'd)

MODULE	PROGRAM	SUBROUTINE	ENTRY POINT	DESCRIPTION	
SEQCON	PGPPRG	SEQUENC RESPOND		SEQUENCE CONTROL MODULE PPP MAIN PROGRAM CENTRAL PPP CONTROL PROGRAM DETERMINE/EXECUTIVE S/W FOR COMMAND	
		ACCESS		PROCESS COPY COMMAND	
			ACCRUN	PROCESS RUN COMMAND	
			ACCBTCH	PROCESS BATCH COMMAND	
			ACCTERM	PROCESS TERMINATE COMMAND	
			SOURCE	PROCESS SLASH (/) COMMAND	
			COMPARE	PROCESS COMPARE COMMAND	
			ACCSWTH	PROCESS SWITCH COMMAND	
			PRESENT	PROCESS COMMAND COMMAND	
			PRESCUE	PROCESS CUE COMMAND	
			PRESERR	PROCESS ERROR COMMAND	
			SYNCTMP	PROCESS REPEAT COMMAND	
			CONTEMP	PROCESS CONTINUE COMMAND	
			PRESMNU	PROCESS DISPLAY COMMAND	
			ACCGRPH	PROCESS GRAPH COMMAND	
			GRAPHLMN	PROCESS GRAPH = L,M,N COMMAND	
			ACCOMP	PROCESS ICOMPARE COMMAND	
			SELECT	PROCESS DISPLAY = L,M,N COMMAND	
				SELNO	PROCESS NUMBER COMMAND
				SELPLS	PROCESS PLUS (+) COMMAND
				SELMNS	PROCESS MINUS (-) COMMAND
				SELBAK	LIMIT TESTING FOR NEW FORMATTER
			JOBLOAD		LOAD/EXECUTE JOB (OVERLAY)
		AMESSAGE		DISPLAY USER SUPPLIED MESSAGE	
		CUECK		UPDATE CUE RECORD SUMMARY	
		ERROR		PROCESS ERROR DESCRIPTIONS	
			ERRSPEC	DIRECT RETURN FOR ERROR ROUTINE	
	JOBLIST		CONSTRUCT DISPLAY COMMAND TABLE		
		JOBSTAR	PROCESS * COMMAND		
		JOBOLD	EXECUTE OLD JOB		
		JOBCLR	PROCESS CLEAR COMMAND		
	HARDPRO		HARDCOPY REQUEST PROCESSOR		
	OLDTIME		PROCESS REPEAT COMMAND		
	SYNCRO		DATA FILE POSITIONING-REPEAT		
	TPRESENT		REPOSITION DATA FILES-CONTINUE PRESENT LEVEL 1 DISPLAYS		

TABLE 3.3-1 PPP Software Functions Description (Cont'd)

MODULE	PROGRAM	SUBROUTINE	ENTRY POINT	DESCRIPTION
RTFACE		RELTIM		REAL TIME INTERFACE MODULE REAL TIME EXECUTOR
INOUT		CMDIN CMDPAK DSPLIT	DSPHRD	MAJOR CYCLE INPUT/OUTPUT MODULE READ USER COMMAND INPUT DATA CONSTRUCT COMMAND BUFFERS CONSTRUCT/WRITE DISPLAY OUTPUT CONSTRUCT DISPLAY OUTPUT FOR POST-RUN HARDCOPY RECONSTRUCTION
		INBUF OUTBUF IOSERV		MASS STORAGE/RANDOM ACCESS INPUT MASS STORAGE/RANDOM ACCESS OUTPUT I/O MODULE EXECUTIVE
		PAGEIT PRNTIT STPLINE CBUFIN CBUFOUT	IOSPEC IOBUF	I/O PROCESSING-RETURN INPUT OUTPUT ONLY PROCESSING PROCESS UP/DOWN PAGE COMMANDS HARDCOPY OUTPUT PROCESS UP/DOWN LINE COMMANDS PROCESS/WAIT FOR BUFFER IN PROCESS/WAIT FOR BUFFER OUT
RTIO		RTIO RTINBUF RTOUTBF READMT		REAL TIME INPUT/OUTPUT MODULE R. T. INPUT/OUTPUT EXECUTIVE R. T. BUFFER IN PROCESSING R. T. BUFFER OUT PROCESSING
POSTRUN	CPLQT DBASE EVLUATE HRDCPY			READ MAG. TAPE-SIMULATE SPS POST RUN MODULE CALCOMP PLOT REQUEST DATA BASE MAINTENANCE SUPPORT TRAINING EVALUATION SUPPORT POST RUN HARDCOPY REQUEST PROCESS HARDCOPY COMMANDS PROCESS HARDCOPY DISPLAYS
	MERGE PEQUIP PRCNTRL RECLOG STORAGE	HRDKMD HRDSPLY		MERGE REFERENCE RUN DATA POST RUN EQUIP. SHUTDOWN POST RUN EXECUTOR RECORD LOG DATA RUN DATA STORAGE
PROCR		PROCR		PROCEDURES PROCESSOR MODULE MONITOR/PROCESS SPS PRO DATA
			PROHOLD	HOLD PROCEDURE DATA PROCESSING
			PRORAND	RANDOM PROCEDURES COMPARISON
			PROT1	UTILITY ROUTINE FOR PROCEDURE PROCESSING
			PROT2	UTILITY ROUTINE FOR PROCEDURE PROCESSING
			PROT3	UTILITY ROUTINE FOR PROCEDURE PROCESSING
			PROT4	UTILITY ROUTINE FOR PROCEDURE PROCESSING
			PROT5	UTILITY ROUTINE FOR PROCEDURE PROCESSING
			PROT6	UTILITY ROUTINE FOR PROCEDURE PROCESSING
		PROCOUT		UTILITY ROUTINE FOR PROCEDURE PROCESSING

TABLE 3.3-1 PPP Software Functions Description (Cont'd)

MODULE	PROGRAM	SUBROUTINE	ENTRY POINT	DESCRIPTION
DIFPPR		BUFCHK	BUFCHKT	CHECK STATUS OF PRO RUN BUFFER
		SPSKBRD		CHECK STATUS OF TRN RUN BUFFER
		DIFPPR	HLDKLEN	MON/INTERP/STOR SPS KBRD ENTRY
		DIFPRUN		DIFFERENCE PROCEDURES PROCESS
		CSSEQD		DIFF. PROC. PROC. EXEC
		DIFPHLD		RUN DIFFERENCE PROCESSOR
		DIFSW		CLEAN UP PROCEDURES AFTER HOLD
PERFPR		REFPROD	RMSWHL	SEQUENCE DIFFERENCE
		SDETP		PERFORM SEQUENCE CHECK
		EVENT		HOLD DIFFERENCE PROCESSOR
EVALPR		GRAPH	PERKLEN	SWITCH DIFFERENCE PROCESSOR
		PERFPR		PROCESS COMPARE COMMAND IN HOLD
EVALPR		PERFSTR	MINSET	REFERENCE PROCEDURES DATA
		MINPHA		STORE PROCEDURES DIFFERENCES
PROCFCM	PROCFCM	MINSTR	PERFCUE	PERFORMANCE PROCESSOR MODULE
		PROGEN		DETECT/RECORD MAJOR EVENTS
PERFFM	PERFFM	TIMTIC		CONSTRUCT GRAPHICS DATA
		FIXED		MONITOR/PROCESS SPS PERF DATA
DIFPFM	DIFPRM	DISGEN		PERFORMANCE DATA FILE CLEANUP
		DISGEN		PERF. DATA BUFFER MAINTENANCE
EVALFM	EVALFM	FIXED	EVALFIX	EVAL. PROCESSOR MODULE
		FIXED		COMPUTE PERF. EVAL. DATA
TRAINFM	TRANFM	BUFTRAN		INPUT/OUTPUT MINIPHASE FILES
		UPBACK		INITIALIZE MINIPHASE CODED WORDS
		TSCRIPT		STORE DATA AT CUE TIME
	TRSTATS			PROCEDURES FORMATTER MODULE
				PROC. FORMATTER EXECUTIVE
				GENERATE PROCEDURES
				GENERATE TIME SCALE
				CONSTRUCT FIXED FORMAT DATA
				PERFORMANCE DATA FORMATTER
				PERF. FORMATTER EXECUTIVE
				CONSTRUCT FIXED FORMAT DATA
				DIFFERENCE PROCEDURES FORMATTER
				DIFP. FORMATTER EXECUTIVE
				DIFP. FORMATTER GENERATOR
				PERF. EVAL. FORMATTER MODULE
				PERF. EVAL. FORMATTER EXECUTIVE
				CONSTRUCT FIXED FORMAT DISPLAY
				DATA
				PROCESS PERF. EVALUATION UNIQUE
				FIXED FORMAT DATA
				TRAINING FORMATTER MODULE
				MANAGE TRAINING SCRIPT DATA FILE
				TRAINING FORMATTER EXECUTOR
				PROCESS "↑" AND "↓" COMMANDS
				UNIQUE TO TRAINING DATA ~
				TRAINING SCRIPT FORMATTER
				TRAINING STATISTICS FORMATTER

TABLE 3.3-1 PPP Software Functions Description (Cont'd)

MODULE	PROGRAM	SUBROUTINE	ENTRY POINT	DESCRIPTION
GRAPH	GRAPH	GDI		GRAPHICS FORMATTER MODULE
		GD2		GRAPHICS FORMATTER EXECUTOR
GDPPGP	GDPPGP	INITIAL		LIGHT PEN COMMAND-DISPLAY
		PREPROC		PROCESSING
SPPSUBS	SPPSUBS	READTP		CONSTRUCT ACTIVE MASKS FOR
		HEADFND		LIGHT PEN
SPPSUBS	SPPSUBS	USEROPT		GDP TO PPP DATA TRANSFER MODULE
		BMESSAGE		GDP TO PPP DATA TRANSFER EXECUTIVE
SPPSUBS	SPPSUBS	FILEIN		INITIALIZE GDP/PPP PARAMETERS
		PATMAT		PREPROCESSOR
SPPSUBS	SPPSUBS	GEVENT		READ DATA TAPE (1 FULL RECORD)
		GTIMTIC		READ DATA TAPE (1/2 RECORD)
SPPSUBS	SPPSUBS	GDISCRT		DETERMINE HEADER INFORMATION
		GSPSKBD		INTERPRET USER COMMANDS
SPPSUBS	SPPSUBS	GBUFCHK		DISPLAY MESSAGES ON 211
		FNUMBR		PROCESS FILE INFORMATION DISPLAYS
SPPSUBS	SPPSUBS	HMS		PATERN MATCH LOGIC
		HOLINS		CONSTRUCT MAJOR EVENT CODE WORDS
SPPSUBS	SPPSUBS	SECN.		DETERMINE TIME OF PROCEDURE
		WSHIFT		CONSTRUCT DISCRETE CODE WORDS
SPPSUBS	SPPSUBS	WRDSHFT		CONSTRUCT SPS KEYBOARD CODE WORDS
		WORDSIN		MANAGE REFERENCE DATA FILE OUTPUT
SPPSUBS	SPPSUBS	FASTBUF		FORCE OUTPUT OF LAST BUFFER HALF
		BFOUTRT		PPP SUPPORT SUBROUTINES
SPPSUBS	SPPSUBS	BMARKRT		CONVERT HOLL. TO FLOAT NO.
		BUFINRT		COMPUTE HOLL. HR/MIN/SEC
SPPSUBS	SPPSUBS	BUFMARK		COMPUTE HOLL. MIN/SEC
		BUFOUT		INSERT HOLL. WORDS
SPPSUBS	SPPSUBS	CKBUF		TOTAL SEC. FROM HOLLERITH
		CKBUFRT		WORD SHIFT-MAJOR CYCLE
SPPSUBS	SPPSUBS	IOTESTB		WORD SHIFT-REALTIME CYCLE
		REWIND		TRANSFER HOLL. TO NEW WORD
SPPSUBS	SPPSUBS	REWINDR		FAST BUFFER INPUT/OUTPUT
		SKIPREC		OUTPUT DATA-RT CYCLE
SPPSUBS	SPPSUBS	SKIPRT		PLACE EOR MARK ON FILE-RT CYCLE
		IHMS		INPUT DATA-RT CYCLE
SPPSUBS	SPPSUBS	NUMBR		PLACE EOR MARK ON FILE-MC CYCLE
		NUMERIC		OUTPUT DATA-MC CYCLE
SPPSUBS	SPPSUBS			STATUS CHECK FILE-MC CYCLE
				STATUS CHECK FILE-RT CYCLE
SPPSUBS	SPPSUBS			211 ACTIVITY STATUS CHECK
				REWIND FILE-MC CYCLE
SPPSUBS	SPPSUBS			REWIND FILE-RT CYCLE
				SKIP RECORD ON FILE-MC CYCLE
SPPSUBS	SPPSUBS			SKIP RECORD ON FILE-RT CYCLE
				PPP SUPPORT FUNCTIONS ROUTINES
SPPSUBS	SPPSUBS			COMPUTE INT. SEC. FROM HOLL.
				COMPUTE INT. SEC. FROM HOLL.
SPPSUBS	SPPSUBS			COMPUTE INT. SEC. FROM HOLL.
				INTEGER NUMBER FROM HOLLERITH
SPPSUBS	SPPSUBS			HOLLERITH DATA FROM INTEGER

PPP Program Flow

The PPP program design may be summarized by three computation loops: (1) Real-Time Cycle (RTC), (2) Real-Time Input/Output Cycle (RTIOC), and (3) Major Cycle (MC). The RTC provides the interface with the SPS and the processing required to assemble the run data. The RTIOC processes mass storage data transfer of run data. The MC processes user commands, run data selected for display, and data base input/output. The purpose of this multi-loop design is to insure that (1) processing of the SPS data to run data in the RTC is accomplished and (2) processing of the run data transfer to mass storage in the RTIOC is accomplished regardless of any user intervention within the MC.

Figure 3.3-1 describes the real-time program flow of processing and data exchange of the PPP. The basic data flow starts with the transfer of SPS data (actual or simulated) to the PPP through a common CDC 6400 computer buffer. This buffer consists of two blocks of data (procedures data and performance data) which are transferred each computation cycle. A total of 58 words are transferred each computation cycle. The procedures data block consists of 42 words, and the performance data block consists of 16 words. The amount of data transferred is further maximized by packing of discrete parameters (a maximum of 60 discrettes per word) and through multiplexing techniques.

The PPP Real-Time Interface Module (RTFACE) validates the data and calls the appropriate processor modules to operate on the data. The processor modules transform the data in the transfer buffers into run data (procedures run data and performance run data). The Procedures Processor (PROCPR) interprets the changes in the procedures data from the previous computation cycle and correlates these changes with the Hollerith statements which describe the procedural event. The Performance Processor (PERFPR) decommutates the multiplexed performance data from the SPS transfer buffer and loads it into the appropriate location with a 106

REAL-TIME PROGRAM FLOW
FIGURE 3.3-1

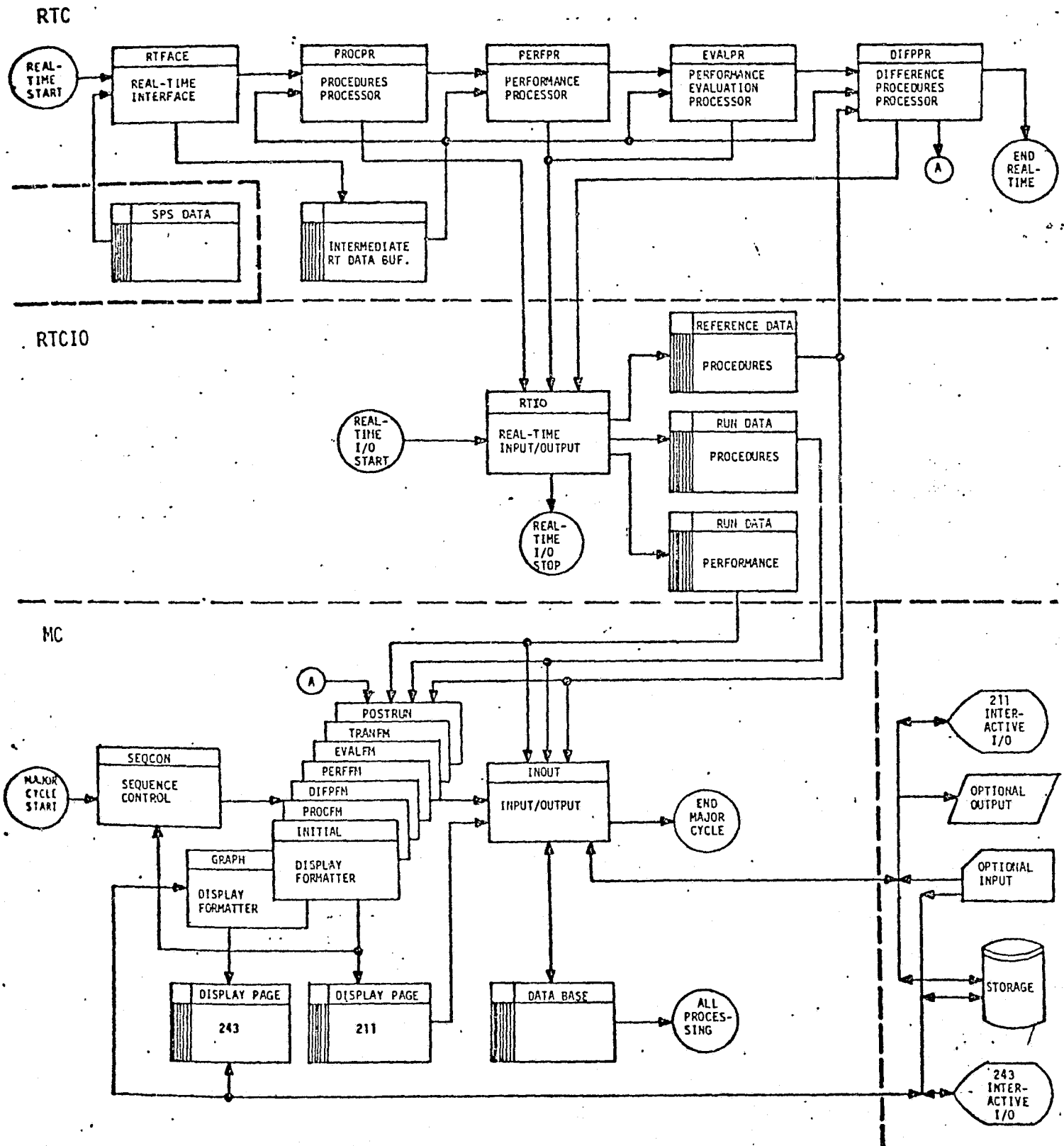

word storage array resident in PPP. The Performance Evaluation Processor (EVALPR), is then executed. Its functions are to (1) compute performance evaluation parameters, (2) maintain maximum, minimum, and deviation values for the user specified miniphase, and (3) detect end of miniphase and process automatic advance to the next successive miniphase.

Following successful completion of the SPS data transfers and execution of the processor modules as described above, the Difference Procedures Processor (DIFPPR) is executed. Procedures run data, along with reference procedures data are compared to determine if procedural difference exist. Completion of the Difference Procedures Processor terminates the RTC and initiates processing within the RTIOC.

Periodically during the RTC loop, requests are initiated to output run data to mass storage, and to input reference procedures data from mass storage. The function of the RTIOC loop is to process these requests and to guarantee immediate response. Depending on the time remaining within the real-time frame, termination of the RTIOC loop initiates processing either in the RTC or MC loop.

The MC loop is processed after completion of the RTC and RTIOC loop during the time remaining in a real-time frame. The MC loop, when reentered, continues processing from the point at which it was terminated to perform the required processing of the real-time frame. The MC processing interprets the user command request for a display output; encodes into the display page data from the run data, internal data, or the data base to satisfy the request; and outputs the display page data to the user interface unit (CDC 211 or CDC 243 Display and Entry Stations).

Other data processing includes PPP Initialization by the Initialization module, reading reference data and data base data from mass storage by the Input/Output module, and processing run termination requests by the Post-Run module.

Figure 3.3-2 indicates a generalized flow of processing and data exchange for the PPP nonreal-time program flow. In this case, the Real-Time module is not used. The Sequence Control module interfaces with selected processors required for display reconstruction. The run data is obtained from mass storage, and all subsequent display processing and data interface stay the same.

3.3.2 PGP Detailed Design

The intent of this section is to highlight the major design features or unique programming features of the PPP. Specific details about the logic for each routine within PPP is addressed in Reference 8. The following paragraphs discuss those features of the PPP program design which may make the design unique to the CDC 6400 computer system on which PPP is operational. Discussions are included for the following: (1) Common Block Description, (2) Overlay Structure and Support Software, (3) CDC 6400 System Software, (4) Real-time Software Routines, (5) Graphics Software Routines, (6) Machine Language Routines.

Common Block Description

Transfer of data between subroutines within PPP is performed via common data blocks. Argument lists are used on support subroutines only. The PPP common blocks and their size are shown in Table 3.3-2. A controlled dictionary of parameters within each common block has been maintained.

The unique features that should be noted about the common blocks design are: (1) the division of parameters into major cycle and real-time cycle data blocks, (2) the allocation of distinct data blocks for procedures (Reference and Run) and performance data, and (3) the allocation of common blocks unique to all the primary overlays.

TABLE 3.3-2 Common Block Description

	COMMON BLOCK NAME	MASTER VARIABLE NAME	DESCRIPTION	SIZE- DECIMAL WORD
MAIN OVERLAYS	REFRUN	REF	REFERENCE PROCEDURES DATA	200
	PRORUN	PRO	PROCEDURES RUN DATA	200
	PERRUN	PER	PERFORMANCE RUN DATA	860
	TRNRUN	TRN	TRAINING RUN DATA	200
	RMCPGP	RMC	PPP MAJOR CYCLE REAL PARAMETERS	400
	RUNDATA	INBUFF	SPS TO PPP DATA TRANSFER BUFFER	42
	IMCPGP	IMC	PPP MAJOR CYCLE INTEGER PARA- METERS	1200
	IRTPGP	IRT	PPP R/T CYCLE INTEGER PARA- METERS	1300
	RRTPGP	RRT	PPP R/T CYCLE REAL PARAMETERS	200
	RUNMT	RMT	MAGNETIC TAPE SPS DATA TRANSFERS	1160
	SUBTOTAL			5762
PRIMARY OVERLAYS		ITM	INTEGER PARAMETERS	955
	ITEMP			
	RTEMP	RTM	REAL PARAMETERS	10
	SUBTOTAL			965
			TOTAL	6727

NOTE: (1) The common block statistics presented for the Primary Overlay represent the largest requested size for all existing overlays.

Overlay Structure and Support Software

As previously discussed, the PPP design makes use of overlays where practical in order to save core and to stay within the 20K₁₀ words limitation requirement. Those modules which are required to be in core at all times have been assigned to the main (0,0) overlay. Those modules which are required in core only on an as-requested basis are assigned to primary (I,0) overlays. Further breakdown of requirements has resulted in the assignment of secondary (I,J) overlays within some primary overlays. The overlays are numbered with an ordered pair of numbers (I,J), where I denotes the primary level and J the secondary level. Table 3.3-3 summarizes the structure of the PPP overlay design.

An overlay is a program combined with its subprograms which is converted to absolute form and written to mass storage prior to execution. During execution, overlays are called into memory and executed as requested. PPP has been designed to take advantage of several NASA Program Library Routines (unique to the Building 35 facility) to process Overlays, see Reference 9. Specifically the following control card operations are used to assign the absolute form of the overlays to mass storage.

1. Select - This control card is used to assign multifiles (overlays) to the specified mass storage device.

Format of Control Card - /SELECT (devtype, lfn1, lfn2, lfn3,...etc)

The device type being requested is specified as the 'devtype' parameter. For PPP application, it must be one of the following:

844 - for assignment of the 844 high speed disk pack

854 - for assignment of any 854 disk pack

The file names (lfn1,...) specify the overlay file names.

TABLE 3.3-3 PPP Overlay Structure

OVERLAY		FUNCTIONAL DESCRIPTION/MODULE ASSIGNMENT
PRIMARY	SECONDARY	
0	0	Sequence Control Module (SEQCON) Input/Output Module (INOUT) Real-Time Interface Module (RTFACE) Real-Time Input/Output Module (RTIO) Procedures Processor Module (PROCPR) Performance Processor Module (PERFPR) Support Functions/Subroutines
1	0	Initialization Module (INITIAL)
1	1	Reference Procedures Data Submodule (REFDATA)
1	2	Initialization Identification Data Display Submodule (RECORD)
1	3	Data Base Input Submodule. Including routines READIN And READER
1	4	Initialization Tutorial Display Submodule. (INDTREE)
1	5	Graphical Format Descriptor Submodule. (GRAFMT)
1	6	Initialization Hardcopy Tutorial Display Submodule (HARD)
1	7	Calcomp Plot Tutorial Display Submodule (PLOT)
1	10	Initialization Record Identifier Log Submodule (LOG)
1	11	Real Time Select Submodule (Request)
1	12	Alphanumeric Format Descriptor Submodule (FMTSD1)
1	13	Alphanumeric Format Descriptor Submodule (FMTSD2)
1	14	Alphanumeric Format Descriptor Submodule (FMTSD3)
1	15	Alphanumeric Format Descriptor Submodule (FMTSD4)
1	16	Alphanumeric Format Descriptor Submodule (FMTSD5)
1	17	Alphanumeric Format Descriptor Submodule (FMTSD6)
2	0	Procedures Formatter Module (PROCFM)

TABLE 3.3-3 PPP Overlay Structure (Cont'd)

OVERLAY		FUNCTIONAL DESCRIPTION/MODULE ASSIGNMENT
PRIMARY	SECONDARY	
3	0	Difference Procedures Formatter Module (DIFPFM)
4	0	Performance Evaluation Formatter Module (EVALF)
5	0	Performance Formatter Module (PERFFM)
6	0	Training Formatter Module (TRANFM)
6	1	Training Script Formatter Submodule (TSCRIPT)
6	2	Training Statistics Formatter Submodule (TRSTATS)
6	3	System Utilization Submodule (UTILSUM)
7	0	Post-Run Module (PRCNTRL)
7	1	Training Evaluation Data Submodules (EVLUATE)
7	2	Run Data Storage Submodule (STORAGE)
7	3	Data Base File Clean-up Submodule (DBASE)
7	4	Post-Run Hardcopy Request Submodule (HRDCPY)
7	5	Post-Run Calcomp Plot Request Submodule (CPLOT)
7	6	PPP Run Data Merge Submodule (MERGE)
7	7	Post-Run Record Identifier Log Submodule (RECLOG)
7	10	Post-Run Equipment Shutdown Submodule (PEQUIP)
10	0	Command, Display, Cue And Display Processor Module (TPRESENT)
11	0	Reconstruction Processor Module (OLDTIME)
12	0	Graphical Formatter Module (GRAPH)
13	0	GDP Data Transfer Processor Module (GDP)

2. COPYOVL - This control card is used to copy into mass storage the overlay files in absolute form so that the overlays may be read directly into memory and executed, bypassing the system loader. To accomplish the loading and execution, see calls to OVSET, OVTEST, and OVEC that follow Control Card format.

COPYOVL(IN, OUT1, OUT2, OUT3, ... OUTN)

Copies from IN to OUTN, one record per OUTN

The following FORTRAN-callable routines, maintained on the NASA Program Library are used by PPP to process the requested overlays. The routines allow the user to monitor the loading and execution of overlays. The following example is presented as an explanation of these routines. Each call should be made in order listed in the example.

1. CALL OVSET (LIST,SCRATCH)

LIST is an array of job names assigned to each overlay. The list is left justified, zero fill, and is terminated by a zero name.

```
EXAMPLE
DIMENSION NAMES(6)
DATA NAMES/3LABC, 3LDEF, 3LIJK, 3LLMN, 3LOPQ,0/
DIMENSION SCRATCH(100)
CALL OVSET(NAMES,SCRATCH)
```

SCRATCH is the area to be used by OVSET as a buffer, must be at least 64 words in length (one pru). OVSET is an initialization routine to prepare for loading. This routine need only be called once each time the job is executed.

2. CALL OVLOAD(LIST(I))

LIST(I) is pointer to name of overlay to be loaded.

```
EXAMPLE
I=3
CALL OVLOAD(NAMES(I))
```

This will load IJK in above example. OVLOAD will begin reading specific overlay, but return immediately to calling program.

3. OVTEST(LIST(I))

OVTEST will return a zero if the overlay file LIST(I) has not yet completed its load, otherwise it rewinds the file and returns a one.

```
EXAMPLE  
IF(OVTEST(NAMES(I)) 10,20
```

4. CALL OVXEC(LIST(I))

OVXEC will begin execution of the overlay that was loaded from file LIST(I).

```
EXAMPLE  
CALL OVXEC(NAMES(I))
```

The program recycles to step 2 each time a new overlay is requested.

CDC 6400 System Software

Since the PPP has been developed using the CDC 6400 computer, and the FORTRAN IV program language, the PPP software has taken advantage of several system software routines. Table 3.3-4 presents the FORTRAN callable system software functions and subroutines used in PPP. A description of the routine and its usage is presented in the table; additional information may be obtained from Reference 10

Table 3.3-4

Description of CDC 6400 System Software Used in the PPP Design

ROUTINE	TYPE	DEFINITION	EXAMPLE USAGE	PARAMETER DEFINITION
ABS	Intrinsic function	Compute absolute value of real number	Y=ABS(X)	
AND	Intrinsic function	Compute logical product	C=AND(A1,A2) or C=A1.AND.A2	
COMPL	Intrinsic function	Compute compliment of octal word	B=COMPL(A)	
DATE	External function	Compute date (MM.DD.YY)	WHEN=DATE(D) or CALL DATE(WHEN)	
LOCF	External function	Compute control memory address of argument	I=LOCF(X)	
IABS	Intrinsic function	Compute absolute value of integer number	J=IABS(I)	
MASK	Intrinsic function	Generate a left justified bit mask of 1 bits	J=MASK(I)	
MAXO	Intrinsic function	Choose largest value from argument list of Integer parameters	L=MAXO(I1,I2,..,IN)	
MINO	Intrinsic function	Choose smallest value from argument list of Integer parameters	L=MINO(I1,I2,I3,..,IN)	
MOD	Intrinsic function	Perform module arithmetic for Integer parameters	J=MOD(I1,I2)	
OPENMS	Subroutine	Open mass storage random access files	CALL OPENMS(U,IX, L,P)	U=logical unit no. IX=first word address of file index in core L=index length P=indicates how file is referenced (=1 for name index)
OR	Intrinsic function	Compute logical sum	D=OR(A1,A2)	
READMS	Subroutine	Read mass storage random access file	CALL READMS(u, fwa,n,i)	u=logical unit no. fwa=central memory address of where to plan the file n=number of words i=file name
SHIFT	Intrinsic function	Shift a_1 by a_2 bit positions: left circular if a_2 is positive; right with sign extension if a_2 is negative	B=SHIFT(A1,A2)	
TIME	External function	Determine current reading of system clock (HH.MM.SS)	C=TIME(A) or CALL TIME(C)	
WRITMS	Subroutine	Write random access files to mass storage	CALL WRITMS(u,fwa, n,i)	See description under READMS

Real-Time Software Routines

The CDC Scope 3.4.1 Real-Time System has been designed as an addition to the standard 6000 series SCOPE operating system to provide users of hybrid equipment with time-critical operating capability. The PPP as a real-time program takes advantage of this capability. Specifically FORTRAN callable subroutines in the Scope 3.4 are used by PPP to perform the real-time task.

Table 3.3-5 presents a synopsis of the Scope 3.4.1 Real-Time System routines used in the design of the PPP. Further description of these routine and the Scope 3.4.1 Real-Time System may be found in Reference 11.

TABLE 3.3-5 SCOPE 3.4 REAL TIME SOFTWARE ROUTINES USED BY PPP

ROUTINE	DESCRIPTION	CALL FORMAT	ARGUMENT LIST DESCRIPTION	
			PARAMETER	DEFINITION
ITRANH	This routine initializes the transfer table from the PPP to the SPS	CALL ITRANH (OUTBUF, ISIZE)	OUTBUF	First word address of the output buffer in the PPP.
			ISIZE	Maximum number of words in the output buffer
RTCON	This routine is used to initially define the PPP Software interrupts	CALL RTCON (INT, ITIME, SUBROUTINE, ICOUNT, IRESET)	INT	Software interrupt number
			ITIME	Compute time of the software interrupt in 256 microsecond units
			SUBROUTINE	The name of the PPP subroutine to be processed when the interrupt occurs.
			ICOUNT	Address of the computer time overrun counter
			IRESET	Reset program address register flag 0 - Do not reset register 1 - Reset to subroutine first executable instruction after overrun occurs
RTRUN	RTRUN is used to bring all currently defined frame jobs and software interrupts into real time	CALL RTRUN (IMODE, IERR)	IMODE	Mode of operation 1* start internal timers and enter real-time mode
			IERR	Integer variable word which will receive an error code when the program leaves real-time mode incorrectly

TABLE 3.3-5 SCOPE 3.4 REAL TIME SOFTWARE ROUTINES USED BY PPP (Cont.)

ROUTINE	DESCRIPTION	CALL FORMAT	ARGUMENT LIST DESCRIPTION	
			PARAMETER	DEFINITION
RTINT	This routine activates the specified software interrupt(s) in the real time job. Software interrupts are processed on a priority basis using the unused RCT (Required compute time of the frame job(s))	CALL RTINT (IND, INT, INT ₂ , ... INT _n)	IND	Global parameter indicator 0 - All previously defined software interrupts (via RTCON) are to be affected. The remaining parameters in calling sequence are ignored. NONZERO - Only those software interrupts specified in the remainder of the calling sequence are to be affected
RTID	RTID is used to establish a control point identifier used for synchronization and integrated run data transfer between the PPP and SPS	CALL RTID (2HID)	ID	An alphanumeric two character control point identifier
RTIDLE	This routine allows the real time PPP program to enter real time idle mode thus relinquishing the remainder of its RCT (Required Computer time) for the frame for use by the system.	CALL RTIDLE (LOC)	LOC	An integer variable address which will contain the unused time (16 microsecond units) of the frame job/software interrupt.

TABLE 3.3-5 SCOPE 3.4 REAL TIME SOFTWARE ROUTINES USED BY PPP (Cont.)

ROUTINE	DESCRIPTION	CALL FORMAT	ARGUMENT LIST DESCRIPTION	
			PARAMETER	DEFINITION
RTEND	The real time end routine (RTEND) puts a job into batch (non-real time) mode and program control is returned to the point at which RTRUN is called	CALL RTEND		
BHOLD	The routine BHOLD suspends the batch (non-real time) background job. The routine is processed after entering real time mode (after a call to RTRUN)	CALL BHOLD		
RTIME	This routine is used to initially define a frame job.	CAU RTIME (IFJ, IFRCT, IFFT, SUBROUTINE, ICOUNT, IRESET)	IFJ	Frame job number
			IFRCT	Required computer time for the frame job in 256 microsecond units
			IFFT	Required frame time for this frame job in 10 microsecond units
			SUBROUTINE	The name of the PPP subroutine to be processed when the frame job interrupt occurs
			ICOUNT	Address of the computer time overrun counter
			IRESET	Reset program address register flag 0 - Don't reset 1,- Reset register to subroutine first executeable instruction after an interrupt occurs.

TABLE 3.3-5 SCOPE 3.4 REAL TIME SOFTWARE ROUTINES USED BY PPP (Cont.)

ROUTINE	DESCRIPTION	CALL FORMAT	ARGUMENT LIST DESCRIPTION	
			PARAMETER	DEFINITION
TRANSH	This routine is used to read data from the SPS control point	CALL TRANSH (2HID, INBUF, NWORDS, INDEX, IND, NREC)	ID	Two character identifier of the control point from which to read data
			INBUF	Address of the buffer area into which data from the other job is to be transferred
			NWORDS	Number of words to be transferred
			INDEX	Integer offset from the sending program's base address
			IND	Indicator of the status of the recieved transfer
			NREC	Number of words actually transferred
RTMOVE	This routine allows a storage move to take place for the real time control point if such a move has been requested by the monitor system. The routine is called periodically to allow relocation of the PPP program in central memory for more efficient system utilization	CALL RTMOVE (MOVE)	MOVE	Storage move occurrence flag: 0 - No storage move occurred NONZERO - A storage move took place

TABLE 3.3-5 SCOPE 3.4 REAL TIME SOFTWARE ROUTINES USED BY PPP (Cont.)

ROUTINE	DESCRIPTION	CALL FORMAT	ARGUMENT LIST DESCRIPTION	
			PARAMETER	DEFINITION
RTPFJ	Establishes a previously defined frame job as the primary frame job	CALL RTPFJ (IFJ, IFLAG, ITYPE)	IFJ	Number of the frame job defined by RTIME that will be designated as the primary frame job
			IFLAG	If non-zero, the primary frame job will begin processing prior to the completion of hybrid input at start of frame
			ITYPE	Timer type 1- ADLC internal timer 2- software clock 3- 930/930D External clock 4- External frame job at another control point, establishes this job as a slave job

Graphics Software Routines

The PPP has been designed to operate in conjunction with the CDC 243 Interactive Graphics System. Use of this system by the PPP requires access to Grid Resident software. The 243 Graphics software routines utilized by the PPP are described in Table 3.3-6. Further description of these routines and the CDC 243 system may be found in Reference 12 and 13.

Utilization of the Graphics system requires that these routines be assembled within the allocated field length of the PPP. Since core resource allocation of the PPP is so limited, all graphics software was implemented in primary and secondary overlays. Primary Overlay (12,0) contains the graphics display software, and secondary overlay (1,5) contains the graphics format construction software.

Machine Language (COMPASS) Software Routines

The basic design philosophy of the PPP was to utilize FORTRAN programming techniques for all PPP applications software. With the exception of two routines, RESPOND and FASTBUF, this goal has been satisfied.

TABLE 3.3-6 GRAPHICS SOFTWARE ROUTINES ACCESSED BY PPP

ROUTINE	DESCRIPTION	CALL FORMAT	ARGUMENT LIST DESCRIPTION	
			PARAMETER	DEFINITION
GIMASK	Sets masks used by the queue handler to screen the type codes of picked ID blocks.	CALL GDMASK (NCON, IDDTC, IDDTs, IMASK)	NCON	Number of the console for which the mask is used
			IDDTc	Value of the bit pattern to be cleared from the pick processing mask
			IDDTs	Value of the bit pattern to be set in the pick processing mask
			IMASK	Mask indicator
GIANS	Enables the terminal keyboard and processes keyboard inputs.	CALL GIANS (NCON, NC, IH, IV)	NCON	Number of console on which keyboard inputs are made
			NC	Maximum number of characters to be input by keyboard
			IH, IV	Coordinate of the starting point of the displayed characters
GIANE	Disables the keyboard and erases the display	CALL GIANE (NCON, NC, IBUF)	NCON	Number of the console on which alphanumeric inputs may be entered
			NC	Maximum number of characters that may be transferred to IBUF
			IBUF	Output display buffer

TABLE 3.3-6 GRAPHICS SOFTWARE ROUTINES ACCESSED BY ppp (Cont.)

ROUTINE	DESCRIPTION	CALL FORMAT	ARGUMENT LIST DESCRIPTION	
			PARAMETER	DEFINITION
GICNJB	Initialize the GRID console and clears the display screen.	CALL GICNJB (NCON, IEDIT)	NCON	Number of console to which the job is assigned NCON = 1
			IEDIT	Optional parameter not used by ppp
GICNRL	Release the GRID console from the applications job	CALL GICNRL (NCON)	NCON	Number of console to which the job is assigned NCON = 1
GIDISP	Transfer a byte-stream from the user's buffer to the GRID display buffer causing an item to be displayed	CALL GIDISP (NCON, IBUF, NBYTE, IDDAD, IDDT, IDDC, IDWA, IDWB)	NCON	Number of console to which item is displayed
			IBUF	Byte-stream input buffer
			NBYTE	Number of bytes in bytes stream
			IDDAD	Associative address of byte stream
			IDDT IDDC IDWA IDWB	Optimal parameters specifying ID parameter

TABLE 3.3-6 GRAPHICS SOFTWARE ROUTINES ACCESSED BY PPP (Cont.)

ROUTINE	DESCRIPTION	CALL FORMAT	ARGUMENT LIST DESCRIPTION	
			PARAMETER	DEFINITION
GIBUT	Fetches button pick ID blocks	CALL GIBUT (IR, NCON, IDDT, IDDC, IDWA, IDWB, IH, IV)	IR	Code specifying to wait/not wait for button pick
			NCON	Number of console
			IDDT, IDDC, IDWA, IDWB	ID BLOCK INFORMATION
			IH, IV	Light pen coordinates at time of light pen strike
GUSEGS	Generates a line segment	CALL GUSEGS (IH1, IV1, IH2, IV2, IBEAM, ISTYLE, IBUF, NBYTE, MBYTE)	IH1, IH2,	Horizontal and vertical coordinate increments for the line segment, in grid units
			IBEAM	Beam control parameter = 0, off = 1, on
			ISTYLE	Line style parameter = +0, solid line = +1, dashed line
			IBUF	Output buffer containing display byte stream
			NBYTE	Number of byte in buffer upper limit of NBYTE
GURSET	Causes beam to be turned off and moved to a new location on the screen.	CALL GURSET (IH, IV, ICODE, IBUF, NBYTE, MBYTE)	IH, IV	New location of the CRT beam in grid units
			ICODE	Bit pattern describing beam control
			IBUF	Output buffer containing display byte stream
			NBYTE	Number of bytes in stream
			MBYTE	Upper limit by NBYTE

TABLE 3.3-6 GRAPHICS SOFTWARE ROUTINES ACCESSED BY PPP

ROUTINE	DESCRIPTION	CALL FORMAT	ARGUMENT LIST DESCRIPTION	
			PARAMETER	DEFINITION
GUAN	Generate alphanumeric characters	CALL GUAN (ICHR, NC, IBUF, NBYTE, MBYTE, IFONT)	ICHR	Input buffer of display code word
			NC	Number of characters from ICHAR to be displayed
			IBUF	Output buffer containing display byte stream
			NBYTE	Number of bytes in stream
			MBYTE	Upper limit of NBYTE
			IFONT	Specifies size and orientation of the characters

3.4 PPP Support Data

PPP Support Data includes the PPP Data Base, PPP Data Base Support Programs, and PPP Data Files. The following summarizes each of these elements.

3.4.1 PPP Data Base

The PPP data base is divided into six sections. The following describes the content of each of these sections.

1. Hollerith Statements Data - This section contains the English language data used by the PPP to translate simulator data to procedures and difference procedures.
2. Format Descriptor Data - This section contains the user oriented PPP recognizable, instructions that define the alphanumeric and graphical display formats. Format descriptors are maintained as random access files which are accessed on user display request. Current design provides a maximum of 100 alphanumeric and 100 graphical format descriptors.
3. Difference Procedures Data - This section contains the criteria data which determines when the PPP will perform configuration difference and sequential difference tests and the switch groups and events included in the automatic difference tests.
4. Reference Procedures Data - This section contains the procedures data from previous runs which may be used as the nominal time history reference for difference comparison.
5. Training Statistics Data - This section contains the training statistics labels which define the exercise descriptions, mission descriptions, and crew/non crew names.
6. Error Detection Labels - This section contains the Hollerith label describing user errors.

3.4.2 PPP Data Base Support Programs

The following defines the digital computer programs that are necessary to maintain the PPP Data Base.

Program PGPSTOR - The alphanumeric display format descriptors in the PPP data base are stored permanently as a sequential data file on magnetic tape. PGPSTOR reads this magnetic tape and loads the PPP data base and file index table as random data files within the PPP computer system.

Program PGPRTOS - This program reads the random data files and file index table for the alphanumeric display formats descriptors within the PPP computer system and creates a new permanent sequential data file on magnetic tape.

Program GRSTOR - The graphical display format descriptors in the PPP data base are stored permanently as sequential data file on magnetic tape. GRSTOR reads this magnetic tape and loads the PPP data base and file index table as random data files within the PPP computer system.

Program GRRTOS - This program reads the random data files and file index table for the graphical display formats descriptors within the PPP computer system and creates a new sequential data file on magnetic tape.

Program PGPFIL - The original design of the hollerith statements data and difference procedures criterion data provided for the maintenance and PPP access to the data as part of the random data files. This data was maintained with the random data files for the alphanumeric display format descriptors. This design required the allocation of a large common block within the PPP software to have access to the data. This design was not feasible because of the core limitations under which the PPP is constrained.

The digital support program, PGPFILE, was designed to convert the original design to a less restrictive design. The resulting design is discussed in the following section, PPP Data Files Description, of this design note. The program also provide the capability to redefine and update the hollerith statements and difference procedures criterion data. The capability to maintain this data is being incorporated into the PPP software; therefore, eliminating the need for the support program in near future.

Program CNREF - Reference Procedures: Data for the PPP difference procedures capability are maintained on magnetic tape and loaded each morning into the reference data file as part of the PPP initial start deck capability. Program CNREF provides the capability to update the existing reference procedures data tape. The program update the Record Identifier file on the tape and incorporate the new file of reference procedures data. This capability will eventually be incorporated as part of the PPP software.

3.4.3 PPP Data Files Description

The data transferred from the SPS to the PPP is operated on and recorded in data file maintained by the PPP. Other data files are maintained by the PPP which contain display, statistics, and reference data. A brief description of the format and content of each of these data files is presented below:

1. Procedures Run Data File (PRODATA) - This file contains the time tagged coded data parameters describing the procedures, procedural events, and resulting difference procedures for the current SPS/PPP run. A unique set of coded words is used for each entry into the PRODATA file. Figure 3.4-1 presents a typical snapshot summary of a procedures data file record. It should be noted that the current design of PPP uses the maximum word size (60 BITS) of the CDC 6400 to code the procedures data.

Figure 3.4-1

TYPICAL PROCEDURES DATA FILE
Structure and Content

4	0	1	(RUN I.D. DATA)	(IWOUT)	1
= TIME (=0.0)					
= IDISPLY (11)					
= IDISPLY (12)					
= IDISPLY (13)					
= INBUFF (2)					
= INBUFF (3)					
= INBUFF (4)					
= INBUFF (5)					
= INBUFF (6)					
= INBUFF (7)					
4	0	3	(EVENT (A))	(IWOUT)	9
= TIME (I)					
= EVENT (A) I.D.# (DATA BASE I.D.#)					
= ISPSDB (1,2)					
= ISPSDB (2,2)					
= ISPSDB (3,2)					
= ISPSDB (4,2)					
= ISPSDB (5,2)					
= ISPSDB (6,2)					
0	0	4	(DISCRETE CHANGE)	DATA BASE I.D.# (INTEGER)	
= TIME					
0	0	4	(DISCRETE CHANGE)	DATA BASE I.D.# (INTEGER)	
= TIME					
4	1	6	(HOLD CONFIGURATION DIFFERENCES)	(IWOUT)	6
= TIME					
ACTUAL (DATA BASE I.D.#)			REFERENCE (DATA BASE I.D.#)		
ACTUAL (DATA BASE I.D.#)			REFERENCE (DATA BASE I.D.#)		
ACTUAL (DATA BASE I.D.#)			REFERENCE (DATA BASE I.D.#)		
ACTUAL (DATA BASE I.D.#)			REFERENCE (DATA BASE I.D.#)		
4	2	6	(EVENT (A) + ΔTIME) PET	(IWOUT)	7
= TIME					
= EVENT (A) (DATA BASE I.D.#)					
= DT (+ ΔTIME)					
ACTUAL (DATA BASE I.D.#)			REFERENCE (DATA BASE I.D.#)		
ACTUAL (DATA BASE I.D.#)			REFERENCE (DATA BASE I.D.#)		
ACTUAL (DATA BASE I.D.#)			REFERENCE (DATA BASE I.D.#)		
0	0	4	(DISCRETE CHANGE)	DATA BASE I.D.# (INTEGER)	
= TIME					
4	4	6	(SEQUENCE DIFFERENCE LIST) = A	(IWOUT)	6
= TIME					
= EVENT (A) (DATA BASE I.D.#)					
= DT (+ ΔTIME)					

The PRODATA file consists of multiple records (each record = 100 words) of recorded data from the start to the end of a run. A double buffer array (two 100 word blocks) representing the PRODATA file is allocated within the PPP program field length for recording the run procedures as they occur. As these arrays are filled, they are buffered out to mass storage and saved until the end of the simulation exercise. Double buffering techniques (recording in one buffer half while copying the other buffer half to mass storage) are used to maintain the PRODATA File.

2. Performance Run Data File (PERDATA) - During a run the performance data processor maintains for display processing current performance parameters transferred from the SPS and performs the necessary computation of desired performance parameters not included in the SPS transfer. The current value of 106 performance parameters is maintained by the PPP. At a user specified frequency this block of 106 parameters is transferred into a double buffer array (two word blocks) internal to PPP. As these arrays are filled they are buffered out to mass storage (PERDATA) and saved until the end of the simulation exercise. Double buffer output techniques are used to maintain the PERDATA file.
3. Reference Procedures Data File (REFDATA) - This file contains the coded word parameters describing the procedures, procedural events, and resulting difference procedures from a previous SPS/PPP run. The format of data and structure of the REFDATA file is identical to that of PRODATA. The user has the option to select from the available set of reference data files during program initialization.
4. Statements and Criteria Data File (PGPSTMT) - This file contains the Hollerith statements and difference procedures criteria data. The file consists of 1916 records. Each record contains 6 words. The data base structure is shown in Table 3.4-1.

Table 3.4-1 PPP Data Base

RECORD NO.	DESCRIPTION	
1-360	ADLC1 Input Discrete Labels	WORDS 1-3 OFF STATEMENT
361-720	ADLC2 Input Discrete Labels	WORDS 4-6 ON STATEMENT
721-1080	ADLC1 Output Discrete Labels	
1081-1440	ADLC2 Output Discrete Labels	
1441-1540	SPARE	
1541-1640	Major Events Labels	
1641-1674	Difference Procedures-Switch Group Table	
1675-1691	Difference Procedures-Pre-Established Comparison Time	
1692-1708	Difference Procedures-Sequence Comparison Table	
1701-1748	A to D Signal Labels	
1749-1769	Miscellaneous Labels-Single Word Labels	
1770-1800	Miscellaneous Labels-Three Word Labels	
1801-1850	Error Description and Recovery Messages	
1851-1856	Training Data-Mission Code Identifiers	
1857-1866	Training Data-Crewman Codes	
1867-1916	Training Data-Exercise Descriptions	

5. Training Script Data File (TRNDATA) - This file contains the time tagged coded word parameters describing the simulation characteristics (I.C data) and SPS instructor and PPP user for the current SPS/PPP run. A unique set of coded words is used for each entry into the TRNDATA file. The coded words are designed consistent with one ground rules of the PRODATA file. Specific details of the coded word descriptions recorded in the TRNDATA file are documented in PPP Working Paper No. 33, Reference 14.

A double buffer array (two 100 word blocks) representing the TRNDATA file is allocated within the PPP program field length for recording the run operations as they occur. As these arrays are filled, they are buffered out to mass storage and saved until the end of the simulation exercise. Double buffering techniques are used to maintain the TRNDATA file.

6. Crew Training Statistics Data File (TCREW) - File TCREW consists of ten-word records, one record per crewman, containing relevant data concerning a crewman's participation in an SPS training session. Inputs to this file are made in the POST-RUN module at display FMT711. This is the only point when crew training data may be recorded. The first record is unique in that only the first word contains usable data. The first word contains the total number of crew training records contained in the file. This record is automatically updated by the software when new inputs are made to the file. The second and succeeding records are in the following format:

WORD	1	DATE-OF-RUN
	2	CREWMAN'S NAME
	3	CREWMAN'S POSITION (PILOT, ETC.)
	4	LENGTH OF RUN (TOTAL SECONDS)
	5	COMPLETION CODE
	6	TRAINING EXERCISE NUMBER
	7	CREW/NON-CREW FLAG
	8	PRIME/BACK-UP CREW FLAG
	9	TRAINING MISSION I.D.
	10	SPS I.C. NUMBER

7. Non-Crew Training Statistics Data File (TNON) - This file contains relevant data concerning a non-crewmember's (i.e., instructor, SPS personnel or anyone other than designated crewmembers) participation in an SPS training activity. Each record in this file is ten-words long with one record allocated per participant in the run. The first record of the file contains only one word of relevant data, the number of non-crewmember training records in the file. The other nine words are ignored. The second and succeeding records are in the following format:

WORD	1	DATE-OF-RUN
	2	PARTICIPANT'S NAME
	3	POSITION-IN-RUN (PILOT, COMMANDER, ETC.)
	4	LENGTH OF RUN (TOTAL SECONDS)
	5	COMPLETION CODE
	6	TRAINING EXERCISE NUMBER
	7	CREW/NON-CREW FLAG
	8	PRIME/BACK-UP CREW FLAG
	9	TRAINING MISSION I.D. NUMBER
	10	SPS I.C. NUMBER

8. System Utilization Data File (TSYS) - File TSYS contains an accounting of the time that the SPS was used for training activities. This file contains three one-word records. Record one contains the total time (in seconds) that the SPS was used for crew training activities. Record two contains the total time (in seconds) that the SPS was engaged for non-crew related training or usage. Record three contains the sum of records one and two, the total time that the SPS was utilized. The format of this file is summarized below:

RECORD 1: TOTAL CREW RELATED USAGE TIME
RECORD 2: TOTAL NON-CREW RELATED USAGE TIME
RECORD 3: TIME OF SPS UTILIZATION

4.0 REFERENCES

1. McDonnell Douglas ACPDT Design Note No. 7, "Procedures Generation Program Description," dated 20 September 1974.
2. McDonnell Douglas Report MDC W0009, "Procedures and Performance Program - Users Guide," dated 29 August 1975.
3. McDonnell Douglas CPDT Design Note No. 4, "SPS Modification Requirements for Data Transfer," dated 7 May 1974.
4. McDonnell Douglas Report MDC E1006, "Procedures Generation Program Requirements Document," dated 31 January 1974.
5. McDonnell Douglas Report MDC W1006, "Procedures Generation Program Requirements Document," dated 20 December 1974.
6. McDonnell Douglas Report MDC E1043, "Procedures Generation Program Equations Document," dated 15 March 1974.
7. Procedures and Performance Program Working Paper No. 31, "ACPD Requirements Traceability and Top-Level Software Identification," dated 8 May 1975.
8. McDonnell Douglas Report MDC E1195, "Procedures Generation Program Math Flow Charts," dated 3 January 1975.
9. NASA 6400 Program Library - Users Guide
10. Control Data Corporation CYBER 170 Series, CYBER 70 Series, 6000 Series, 7000 Series Computer Systems, "FORTRAN Extended Version 4, Reference Manual," Revision F, dated 5 October 1974.
11. Control Data Corporation, "Scope 3.4.1 Real-Time Reference Manual and Users Guide," dated 6 September 1974.
12. Control Data Corporation, 6000 Computer Systems, "240 Series Interactive Graphics System Reference Manual," Revision F, dated 15 February 1974.
13. Control Data Corporation, 243-1 Grid Display Subsystem, "Operating and Programming Guide," Revision B, dated 18 October 1974.
14. Procedures and Performance Program Working Paper No. 33, "Top Level Design of PPP Training Data Capability," dated 13 June 1975.