

General Disclaimer

One or more of the Following Statements may affect this Document

- This document has been reproduced from the best copy furnished by the organizational source. It is being released in the interest of making available as much information as possible.
- This document may contain data, which exceeds the sheet parameters. It was furnished in this condition by the organizational source and is the best copy available.
- This document may contain tone-on-tone or color graphs, charts and/or pictures, which have been reproduced in black and white.
- This document is paginated as submitted by the original source.
- Portions of this document are not fully legible due to the historical nature of some of the material. However, it is the best reproduction available from the original submission.

**NASA TECHNICAL
MEMORANDUM**

NASA TM X-72796

NASA TM X- 72796

AN OUTLOOK FOR CARGO AIRCRAFT OF THE FUTURE

by Oran W. Nicks, Allen H. Whitehead, Jr.
and William J. Alford, Jr.

November 14, 1975

(NASA-TM-X-72796) AN OUTLOOK FOR CARGO
AIRCRAFT OF THE FUTURE (NASA) 42 P HC \$4.00
CSCI 01C

N76-13038

Unclas
G3/03 04745



This Informal documentation medium is used to provide accelerated or special release of technical information to selected users. The contents may not meet NASA formal editing and publication standards, may be revised, or may be incorporated in another publication.

**NATIONAL AERONAUTICS AND SPACE ADMINISTRATION
LANGLEY RESEARCH CENTER, HAMPTON, VIRGINIA 23665**

| | | | | | |
|--|--|--|--|---|----------------------|
| 1. Report No. NASA TM X-72796 | | 2. Government Accession No. | | 3. Recipient's Catalog No. | |
| 4. Title and Subtitle AN OUTLOOK FOR CARGO AIRCRAFT OF THE FUTURE | | | | 5. Report Date October 17, 1975 | |
| | | | | 6. Performing Organization Code | |
| 7. Author(s) Oran W. Nicks, Allen H. Whitehead, Jr., and William J. Alford, Jr. | | | | 8. Performing Organization Report No. | |
| 9. Performing Organization Name and Address NASA Langley Research Center Hampton, Virginia 23665 | | | | 10. Work Unit No. | |
| | | | | 11. Contract or Grant No. | |
| 12. Sponsoring Agency Name and Address National Aeronautics & Space Administration Washington, DC 20546 | | | | 13. Type of Report and Period Covered Technical Memorandum | |
| | | | | 14. Sponsoring Agency Code | |
| 15. Supplementary Notes | | | | | |
| 16. Abstract This paper provides an assessment of the future of air cargo by analyzing air cargo statistics and trends, by noting air cargo system problems and inefficiencies, by analyzing characteristics of "air-eligible" commodities, and by showing the promise of new technology for future cargo aircraft with significant improvements in costs and efficiency. NASA's proposed program is reviewed which would sponsor the research needed to provide for development of advanced designs by 1985. | | | | | |
| 17. Key Words (Suggested by Author(s)) (STAR category underlined) AIR CARGO SYSTEMS MARKET ANALYSIS FREIGHTER AIRCRAFT DESIGN | | | 18. Distribution Statement UNCLASSIFIED - UNLIMITED | | |
| 19. Security Classif. (of this report) Unclassified | | 20. Security Classif. (of this page) Unclassified | | 21. No. of Pages 41 | 22. Price* \$3.75 |

* Available from { For sale by the National Technical Information Service, Springfield, Virginia 22161
STIF/NASA Scientific and Technical Information Facility, P.O. Box 33, College Park, MD 20740

AN OUTLOOK FOR CARGO AIRCRAFT OF THE FUTURE*

by Oran W. Nicks, Allen H. Whitehead, Jr.
and William J. Alford, Jr.

Langley Research Center

SUMMARY

A review and study of the history, current state-of-the-art, and prospects for future cargo aircraft systems indicate that the advantages of air transport relative to surface modes can be characterized by rapid delivery, bridging of geographical barriers, and flexible market response.

Air cargo demand is forecasted to increase in a dynamic manner. Estimates vary between 11 to 16 percent per year between now and the 1990's. Forecasts indicate a fivefold increase in air cargo traffic from 1975 to 1985.

Dedicated, advanced terminals will be required to support the air cargo system of the future. Intermodal containers and handling systems and computerized control and billing may be key ingredients. Farsighted communities such as Coalinga, California, are already studying the potential benefit of serving as a worldwide aerial trade center. Other nations, particularly in Europe, are seriously considering a network of such dedicated freighters.

Preliminary NASA and industry studies indicate that large gains in aircraft payload and fuel efficiency are possible from the application of advanced technologies and configuration concepts. NASA, working in cooperation with elements of DOD and DOT, has defined and proposed a Very Large Aircraft System Technology Program which includes systems studies, R&T, and the determination of the need for individual flight experiments to demonstrate and validate the promises of advanced technology.

The outlook for Air Cargo Aircraft of the future appears bright but will require extensive research and technology activity to realize the forecasted potential.

INTRODUCTION

Compared to the cargo volume transported by the surface modes, air cargo is still in its infancy. Air cargo service was initiated in the United States in the late 1920's with the airmail service, and experienced significant growth

*Presented by Senior Author at The Aero Club of Buffalo, NY, Oct. 17, 1975

during World War II with the transport of critical military supplies. Military airlift accomplished a truly heroic task in the Berlin airlift in 1949. With the advent of efficient high-speed turbine powered aircraft in the late 1950's and 1960's, the future of air cargo appeared bright.

Indeed, the United States airfreight volume has increased from around 0.3 billion ton-miles in 1950 to 3.4 billion ton-miles in 1972 (ref. 1). Even with this growth, however, the volume of goods transported by air between the U.S. and Europe in 1973 represented less than 0.2 percent of the total carriage (ref. 2). Some aspects of the current environment are illustrated in figure 1. A significant feature of this transatlantic trade is that of the total \$9 billion value of the cargo transported by all modes, the air share is around 25 percent by value. Air carriage is thus already an important factor in the balance of trade. As the photograph suggests in figure 1, considerable improvement can be realized by improved handling techniques.

The purpose of this paper is to provide an assessment of the future of air cargo by analyzing air cargo statistics and trends, by noting air cargo system problems and inefficiencies, by analyzing characteristics of "air-eligible" commodities, and by showing the promise of new technology for future cargo aircraft with significant improvements in costs and efficiency. NASA's proposed program is reviewed which would sponsor the research needed to provide for development of advanced designs by 1985.

The paper will address the following topics:

- o Advantages and Disadvantages of Air Cargo Transportation
- o Air Cargo Demand Forecasts (Civil and Military)
- o Economics of Air Cargo Transport
- o Intermodal Demonstration and Community Planning
- o Airfreighter Evolution and Integration with Future Terminal Systems
- o Proposed NASA Very Large Aircraft Systems Technology Program

DISCUSSION

Advantages and Disadvantages

Compared to surface modes, air-transportation offers three main advantages as illustrated in figure 2. These are: (1) rapid delivery, (2) ability to bridge geographical barriers, and (3) flexible market response.

Rapid delivery is required for perishables (lettuce, livestock, etc.) and seasonal commodities (wearing apparel). Time saved by air transport can reduce costly inventories and warehouse requirements (ref. 3 and 4).

The air system can bridge geographical barriers since aircraft can travel essentially straight-line courses and are not constrained by mountains, streams or oceans. An inherent advantage is elimination of the requirement to change transportation modes at the land-water interface.

A more flexible market response is available since the aircraft speed makes it possible to serve changing market requirements set by consumer demand. A rapid response to volatile seasonal demands, for example, can best be fulfilled by the air mode. The air mode is also adaptable to shifting population centers; in contrast, a rail system involves heavy investment in equipment tied to a fixed network. Because of its adaptability to varied terrain, air transport has a significant potential for accelerating the growth of developing countries (ref. 5). The construction of a network of rail and highways is both expensive and time consuming; airplanes can provide transportation until a complementary ground system can be planned and developed.

The impact of marketing and production errors can be reduced and the cargo is less susceptible to pilferage because of its reduced exposure time.

The principal disadvantages of air are the higher freight rates and the necessity of developing adequate backhaul. In this paper, it will be shown that air cargo can reduce the total distribution cost of many items, even when the air freight rate is significantly higher than the ground mode. A second area involves temporal problems that appear amenable to solution. In that category is included the complex rate structure that is applied to international air transportation. For example, the International Air Transport Association requires unanimous agreement from its carrier members for a commodity rate decision. On the North Atlantic Zone, there are 185 commodity groupings and 19,000 separate rates. To illustrate the confusion, there are different rates for shoes and footwear, cloth and textiles, motorcycle parts and disassembled motorcycles (ref. 2). In today's air cargo network, a large fraction of the system costs are attributed to ground operations. Reductions in costs are possible through more efficient cargo handling, loading, storage and security (refs. 6 and 7). Cargo traffic tends to suffer when accommodated by airlines whose prime focus is on passenger travel; as a result, innovative management and proper equipment are often lacking for air cargo (ref. 8).

Air Cargo Demand Forecasts

To maximize the future growth of air cargo most of these problems must be resolved. Projections based on past air cargo traffic are optimistic. The demand for commercial air cargo is increasing as illustrated in figure 3 (ref. 9). The history and forecasts of demand in terms of revenue ton-miles indicates that the current market demand was preceded by an annual growth rate of approximately 13-1/2 percent since 1960. This market is characterized by high value, unplanned, and perishable goods which could maintain an 11 percent growth rate constituting 0.2 percent of the total world trade. As indicated, about half of this volume would continue to be carried as belly cargo on passenger aircraft and half in dedicated freighters.

Attractive new market opportunities exist for expansion into a much broader spectrum of commodities. A significant increase in scheduled airfreight traffic is forecasted to supplement unplanned shipments. Only moderate cost improvements are required to constitute a breakthrough for air cargo operations. These cost reductions can be achieved by improvements in ground operations or

by more efficient aircraft designs, or both. In 1970, it was shown from available data that a product value of around \$1.00 per pound defined a "threshold" for delineating air-eligible commodities (ref. 6). If reduced air transportation costs allowed that product value to be lowered 25 percent, then an impressive array of major consumer lines would be attractive for air cargo transport (refrigerators, washers, automobiles, etc.). The new market objective shown in figure 3 represents a 16 percent growth rate beyond 1975 and would result in an additional 0.1 percent of the forecasted world trade. This modest stimulation of the market will require a substantial number of new cargo aircraft to meet the projected traffic. For example, the requirement in 1985 equates to about 240 747-F aircraft, or a fewer number of very large aircraft of the multiton gross weight category.

It is well known that the military requires fast-response large airlift capability. This has been demonstrated repeatedly since World War II in Korea, Viet Nam, and several times in the Middle East. Details of one such recent airlift exercise is presented in figure 4 (ref. 10) which deals with the 1973 resupply to Israel during its conflict with the Arab nations. This airlift required 566 total flights over a period of 33 days to transport 22,300 tons over a distance of 6,450 nautical miles, with an intermediate stopover at the Azores. The primary aircraft used in this airlift were the C-141 and C-5A. Other large aircraft such as the Boeing 747 were also utilized but are not included in the statistics of this figure. A wide variety of cargo was transported including pallets containing ammunition, missiles, electronics, etc.; helicopters; cannon; and tanks. Only the C-5A with its massive cargo bay dimensions could carry the M-60 tank and the CH-53 helicopter.

A recent Air Force document (ref. 11) outlines the future requirements for logistic missions that could be served by large freighter aircraft. With existing and ever increasing economic and political pressures such as balance-of-payments and sensitive international political situations, there is a trend to reduce overseas bases and personnel. However, since the Warsaw Pact Nations are planning extremely mobile military force structures, the U.S. must be able to respond quickly by having the capability to move large numbers of troops and materiel to any point in the world. Without adequate intermediate stopover or staging bases, a requirement is seen to exist for aircraft with large payloads and long-range capabilities. One possibility currently under evaluation would consider a common aircraft design for both civil and military airlift.

Economics of Air Cargo Transport

An increase in the air freight share of the market is predicted on an increase in carriage of traditional "air-eligible" commodities as well as some penetration into commodities currently transported solely by surface modes. For this reason, shippers, airlines, and aircraft manufacturers need a clear understanding of the economics of cargo transportation as dictated by the marketplace.

A comparison of 1973 transportation operating costs and marketing characteristics associated with surface and air modes is presented in figure 5 (ref. 12). The long-haul, low value goods are carried primarily by ships and railroads with costs of 0.8 and 1.8 cents-per-ton-mile, respectively. The short-haul, low and medium value goods are carried primarily by trucks at about 4.9 cents-per-ton-mile. For the air mode the goods are characteristically those of the long-haul, high value category. The early airfreighters had relatively high-costs (8- to 9-cents-per-ton-mile) but large improvements have been accomplished by more recent aircraft, such as the Boeing 747 which has a cost of approximately 5-cents-per-ton-mile. As will be shown subsequently, it appears that advanced concepts can further reduce the costs, possibly to values below 4 cents-per-ton-mile.

Even though air transportation rates are generally higher than surface rates, other economic factors must be considered before a manufacturer selects the transportation mode for his product. The concept of "Total Distribution Cost" is introduced in figure 6 and is useful in determining the economic value of time saved by air. For a case typical of the appliance industry, the business dollar is divided into manufacturing, marketing, distribution and profit (ref. 13). The distribution costs for surface and air modes are shown and include transportation, inventory and warehousing costs. Because of the speed advantage of the air mode, warehousing and inventory costs are minimized. As the figure illustrates, while air transportation costs are over 20 percent higher, the total distribution costs are reduced, producing a net cost savings of 3 cents. For a company whose distribution system is built around surface transportation, the change to the air mode can be complex. To derive optimum benefit from air carriage, changes may be necessary in warehousing, production, accounting systems, and even changes in organization. The conversion to air distribution may well be an evolutionary process.

A list of the "top-ten" airfreight commodities is presented in figure 7 (ref. 14), and is representative of the items transported by five U.S. Trunk Carriers (United, American, TWA, Eastern, and Delta). Wearing apparel, particularly women's wear, heads the list because of the time-sensitive, "perishable" consumer demand. Another characteristic of clothing that makes it an attractive air commodity is its high value. The high-value item is more able to absorb the higher air freight rates. The top-ten commodities shown here represent only 37 percent of the total value of \$339 million for these five domestic carriers in 1971. This observation illustrates the wide diversity of products carried by air. Perishables represented only about 15 percent of the revenue produced by the top-ten.

In addition to high-value products, two other product characteristics that lead to "air-eligibility" are fragility and perishability. Television sets are a commodity which are both high-value and fragile. The analysis shown in figure 8 taken from reference 15 illustrates the potential savings in transportation costs for sets manufactured in Japan for distribution through Atlanta, Georgia. The surface mode is characterized by slow-moving conveyances, numerous steps involving considerable handling of the cargo, and highly circuitous routing. Delivery time is three to four months at a per unit cost of \$52. Because the air mode reduces this delivery time to four to five days,

unit cost drops to \$36. This 30 percent savings by air transport is determined by consideration of the capital loss associated with the large inventory tied up in the ground mode "pipeline." Additional savings should also be realized in reduced warehousing costs.

Even for the air mode, considerable additional time and savings could be attained if a "direct-origin-to-destination" pick up and delivery service could be structured to reduce the number of transfers of the cargo between modes. Damage and pilferage would also be reduced. To accomplish this objective, airports would have to be located close to both the supplier and customer or advanced landing systems such as air-cushion systems might be employed to provide an austere or minimum developed field capability near the end points. As will be shown later, such advanced concepts are being studied.

The transport from California to the East Coast of a typical time-sensitive product such as lettuce is illustrated in figure 9 (ref. 16). Presented at the top of the figure is the lettuce freshness condition as a function of transport time, from harvest to delivery, for two values of constant temperature and a temperature variation typical of surface modes. Note that after about ten days, the quality has degraded to a fair condition. Shown at the bottom of the figure are the total distribution costs of both surface and air modes. Although the air fare is about 40 percent higher, the spoilage is reduced from about 25 percent to 1 percent with a resultant net savings of approximately 30 percent. Not considered in this saving is the additional shelf life of the product provided by the rapid delivery with the air mode.

As a final commodity example, figure 10 presents a photograph of a rather unique air cargo - breeding stock cattle transported by the Flying-Tiger Line (ref. 17). Livestock of all types have been air transported from the U.S. to many diverse markets-such as the Philippines, the Far East, Brazil, Hungary, Spain, and Russia. Most of this traffic in live animals is for breeding. In 1972, Flying-Tiger alone delivered 1,500,000 pounds of livestock to international markets. Direct transportation cost from U.S. to Japan is three times higher than surface rates, but the overall distribution cost is only 5 to 10 percent greater. Three factors have encouraged this type of trade: the efficiency of the modern jet freighter; the improvement in the economies of both developed and developing countries (sirloin brings \$11.80 per pound in Japan); and American expertise in raising and breeding livestock.

Intermodal Demonstration and Community Planning

From the type of analysis just considered, it may appear advantageous to ship a certain product by air when the "total cost of distribution" is considered; however, if an efficient ground-support system is lacking, the potential benefits can evaporate. The current problem of excessive cost of ground operations has already been cited (ref. 7). A fresh approach may be needed to reduce these costs which considers the entire transportation system, surface and air. What may be required is an intermodal network dedicated to increasing the total transportation efficiency and capability of the nation, both for military and commercial sectors.

A privately-funded joint venture dedicated to defining the most efficient and cost-effective transfer of cargo between modes is now underway (ref. 18). The Intermodal Air Cargo Test (INTACT) Project has over 40 participants including aircraft manufacturers, airlines, shippers, air forwarders, airports, the Department of Transportation and the U.S. Air Force. The purpose of this project is to prototype test and demonstrate a multimodal systems concept employing the U.S. Air Force Lockheed C-5A "Galaxy" aircraft, various land and sea containers, and unique automated handling and loading concepts. Specific objectives are to: (1) establish a basis for determining specifications for cargo handling equipment, (2) define operational interfaces with surface transportation, and (3) develop an operational data base for projection of systems economics and analyses of total cost distribution. Figures 11 and 12 present aerial and close-up views of recent Project INTACT handling and loading tests. Transcontinental flights and unloading demonstrations have recently been completed between Oakland, California, and Nashville, Tennessee (October 1975). An efficient intermodal air segment linked directly to surface transportation modes is seen as one of the keys to large-volume air cargo operations, however, so it is crucial that this approach be thoroughly evaluated.

Another critical requirement for an efficient air cargo system may be the development of dedicated cargo airports. An example of a farsighted community planning for the future, with prime consideration of aerial trade as a focal point, is illustrated in figure 13 (ref. 19). Coalinga, California, located inland between San Francisco and Los Angeles adjacent to the fertile San Joaquin Valley, has done considerable planning to become a worldwide aerial trade center. With ready access to railroad and interstate highways to facilitate delivery of agricultural goods grown in the valley, the products would be flown to markets all over the world. In this case there is not likely to be a "backhaul" problem since California is a heavy importer of industrial and machine products. The planning and development represented by Coalinga's approach emphasizes the systems analysis methodology in which all elements of the system are considered before committing major resources. As such, Coalinga could serve as the progenitor of tomorrow's aerial trade center. Several references from the transport industry can be cited which allude to the future need for such centers, often referred to as "gateway" centers (ref. 20 for example).

Airfreighter Evolution and Integration with Future Terminal Systems

A brief evolutionary synopsis of airfreighter designs and potential future concepts is presented in figure 14 for both civil and military applications. Although there were earlier aircraft, the real genesis is generally accepted as the Douglas C-47 Skytrain, which had its first flight in 1935. The Douglas C-54 Skymaster, which served both civil and military roles, had its first flight in 1942. The Lockheed C-130 Hercules, a current military workhorse, had its first flight in 1954. The Boeing 747 had its first flight in 1954 and the Douglas DC-8 (series 10) in 1958. The Lockheed C-141 first flew in 1963 and the C-5 in 1968. The Boeing 747 was introduced in 1969. In this 34-year period, the gross weights have increased from 26,000 pounds for the

C-47 to nearly 800,000 pounds for the 747 and C-5 aircraft. During this evolution, the direct operating costs have been reduced from approximately 20 cents per ton-mile for the C-54 to approximately 5.4 cents per ton-mile for the B-747 (based on 1975 costs).

A glimpse at what future large cargo aircraft might look like and weigh is illustrated by the distributed-load aircraft concept and a high aspect ratio, laminar-flow control aircraft. The laminar-flow concept is being studied under an Air Force contract. Other countries, particularly Russia and Germany, are actively planning and even flying prototypes of large aircraft concepts (refs. 21 and 22).

A measure of the payload and fuel efficiency representative of current wide-body commercial and military aircraft and what may be achieved with advanced concepts such as the span-distributed load design is presented in figure 15 (refs. 23-25). NASA and several aircraft manufacturers are investigating the distributed-load concept in which the payload is placed within the wing to partially offset the aerodynamic load. As a result, the net wing bending moment, and thus the structural weight, is significantly reduced. A preliminary NASA analysis (ref. 24) shows the potential benefits and the influence of critical design variables. The application of this concept to the 1990 market is analyzed in reference 25. Critical research and technology is defined in reference 25 that would be required for development of these airplanes in that time period. Other advanced concepts under study include nuclear-powered and hydrogen-fueled configurations. In-flight coupling and decoupling of aircraft and towed systems may provide operational advantages.

The efficiency yardstick of figure 15 is given in the form of revenue-ton-miles per pound of fuel, which is a function of aircraft speed, lift-to-drag ratio, payload-to-gross weight ratio, operating weight-to-gross weight ratio, and specific fuel consumption. The efficiency ratio is plotted as a function of range. The current aircraft have efficiency levels of from two ton-nautical miles per pound of fuel at 2,000 nautical miles to 1.5 at about 7,000 nautical miles. The levels of efficiency estimated to be possible for advanced designs such as the distributed-load flying wing are indicated to be from 70- to 100-percent higher than for current aircraft. As an example to illustrate the benefit of such improved efficiency, the advanced designs could have reduced the number of missions on the Israeli airlift by 77 percent and could have saved 56 percent on total fuel. It should also be noted that the ranges of the advanced aircraft are essentially double that of the current aircraft. Representative estimates of speed, L/D, payload and operating weight ratios are presented in tabular form. A comparison of these values indicates that, relative to current aircraft, the advanced aircraft would probably be somewhat slower because of its thicker airfoil, would have an aerodynamic efficiency about 30 percent higher, have a payload ratio 2.3 times higher, and have an operating weight ratio 50 percent lower.

A multimission air freighter concept which employs a very thick unswept wing (thickness of approximately 20 percent of the wing chord) is shown in figure 16. This version of the distributed-load concept would probably require a small horizontal tail to provide acceptable stability and control. Swept

wing versions of the distributed load concept may not require separate horizontal stabilizing and control surfaces since the wing control surfaces, which would act as elevons, have greater lever arms. Such configurations closely approach "flying-wings" with attendant higher-Mach number capability and higher aerodynamic efficiencies. The straight wing configuration shown in figure 16 utilizes constant-thickness wing sections which would reduce the tooling and manufacturing costs.

Also shown in figure 16 is a cargo loading system to efficiently handle intermodal containers delivered by truck. The loading platform would incorporate multiple-rollers or an advanced air-bearing system demonstrated in a preliminary design concept in Project INTACT (ref. 18).

A large fraction of current operating costs is associated with ground operations (ref. 7). A terminal area concept for the future must be designed to facilitate cargo disposition at minimum overall cost. A dedicated cargo terminal concept which could meet this objective is depicted in figure 17 (ref. 26).

Such a system would be fully mechanized and computer-controlled, with emphasis on high volume, high-speed processing and minimum manpower. Cargo is delivered by truck, sorted and unitized for efficient air shipment, then the palletized or containerized units are sequenced for optimum loading onto the proper aircraft. These operations would all be computer-controlled, including the mechanical operations. The computer system would automatically weight and price each item, provide the proper sequencing, and bill the customer. The computer could be queried for determining the status of any item in the system and to provide data and data analysis for management. The reduced operating costs and efficiencies attributed to higher level of mechanization must be traded off against the increased investment cost of such a system.

The proposed advanced freighters such as depicted in figures 16 and 17 would not be adequately supported by today's air cargo handling system because of their massive payload capacities. The development of efficient cargo terminals and cargo handling systems is an essential ingredient for optimizing tomorrow's air cargo system.

Proposed NASA Very Large Aircraft Systems Technology Program

NASA, in cooperation with the Departments of Defense and Transportation, and the National Science Foundation, is currently involved in a number of activities that are expected to evolve into a Very Large Aircraft Systems Technology Program. Some of the major elements of such a program are shown in figures 18 and 19 with specific examples of various disciplinary activities illustrated in figures 20 through 25.

The program elements are illustrated pictorially in figure 18 and are shown in a proposed schedule in figure 19. These elements consist of systems and design studies, advanced concept development, research and technology

investigations, simulation, and the determination of the need for possible flight experiments or demonstration. Currently, a technology impact assessment of large cargo aircraft is under way with Gellman Research Associates under joint sponsorship of the National Science Foundation and NASA. Preliminary survey systems studies of advanced concepts and capabilities are under way with Boeing, Douglas, and Lockheed Aircraft Companies. Market systems studies are scheduled to be initiated in the near future.

The necessary research and technology elements, some of which are illustrated pictorially in figure 18, include advanced concept development, composite structures, landing systems, flight-controls, propulsive lift, and thick airfoil analysis and experimental development.

Advanced transports will make extensive use of composite materials to reduce structural weight - about 40 percent of the conventional metal structure might be replaced by composites. An illustration of the Advanced Composites Program, under the direction of NASA Langley is presented in figure 20. A recent survey of the NASA program is found in reference 27. Advanced composites are made from thin, high strength fibers such as special glasses, graphite, and boron imbedded in a plastic or, in some cases, metal matrix material. The program will provide design, durability, and maintainability data for composite materials in airline service. This figure shows several pieces of secondary structure that are being evaluated on commercial transports. Some of the parts have been flying for more than 4000 hours and are functioning better than the part they replaced. The sketch at the lower right shows the next step in NASA Langley's Advanced Composites Program. The main load-carrying sections of the wings will be constructed of composites and installed on a commercial transport beginning in the latter part of the decade.

Figure 21 presents a photograph of a 1/90th scale model of a NASA span-distributed load configuration in the Langley 7- by 10-foot wind tunnel. The purpose of these tests is to provide preliminary performance, stability, and control characteristics on three-dimensional models incorporating very thick airfoils (streamwise $t/c = 0.20$), and flying wing concepts. This model is representative of a concept that would have a span of approximately 375 feet and payload of over a million pounds, and a gross weight of approximately 2.5 million pounds. It would employ eight high bypass ratio engines ($BPR = 10$), each having 75,000-pound thrust at sea level.

The iterative process employed in the design of advanced thick airfoils is illustrated in figure 22. Analytic methods, depicted by use of the high-speed computer, account for both compressibility and boundary-layer effects and are used to parametrically determine the best airfoil sections to meet design constraints. Typical results such as pressure coefficient and drag which characterize the airfoil are shown in the figure. Two-dimensional wind-tunnel tests are then conducted to verify the analytic results and to further optimize the performance. For thick airfoils, it is important to test at as high a test Reynolds number as possible in order to adequately simulate flight conditions. Recent surveys of the NASA Langley program in airfoil design are presented in references 28 and 29.

The use of active controls on a large aircraft is illustrated in figure 23. Active Controls Technology (ACT) is the extension of automatic control techniques beyond the usual stability and control functions. The advantages offered by ACT stem from the removal of limitations imposed by the traditional passive methods associated with a fixed-geometry configuration. ACT concepts involve continuously operating control surfaces in one or more feedback loops. Digital computers and fly-by-wire systems would be an integral part of the ACT system (refs. 30 and 31). Active controls may be utilized to reduce trim drag through the use of relaxed static stability (rearward c.g. location) resulting in reduced tail sizes. Wing weight can be reduced with active controls through tailoring the wing span-load distribution to reduce the wing bending moments experienced in maneuvers and gusts. Further gains may be possible through flutter suppression, but this application represents a greater dependence on ACT for safety-of-flight. Finally, active controls can provide better ride quality and handling qualities associated with the large moments of inertia characteristic of very large aircraft. The reliability and maintainability of active controls will require advanced avionics concepts such as fault-tolerant (i.e., "self-healing") computers.

The landing gear systems of large aircraft, particularly the flying-wing type, will pose a difficult and challenging problem. Unless the landing gear loads can be suitably distributed, the advantage of distributing the cargo load can be lost. For conventional wheeled systems - if they are even practical - a large number of multiple bogey's will be required to provide acceptable flotation or surface footprints. The lower sketch in figure 24 illustrates the Air Cushion Landing System (ACLS) concept which has the potential for considerable weight savings and flexibility for use on unprepared or austere fields and for water-based aircraft. While an ACLS system has been demonstrated on current aircraft (see figure 18), the application to large cargo aircraft will require considerable technology development. The experimental methods employed at Langley Research Center for evaluating a typical ACLS application are discussed in reference 32.

NASA Langley's Landing Loads Facility (ref. 33) has been used to test several dynamic models of air cushion equipped aircraft for the Air Force and Navy - including RPV's, fighters, and transport aircraft. Shown in figure 25 is a one-quarter scale (610 pound) model of the 40,000-pound Buffalo Aircraft which is currently undergoing flight test evaluation by the USAF and the Canadian government. The modified Buffalo is shown in figure 18. The track can also be used to verify analytical and empirical techniques for predicting the characteristics of ACLS designs.

CONCLUDING REMARKS

The key elements for future expansion of air cargo are summarized in figure 26. A review and study of the history, current state-of-the-art, and future prospects for cargo aircraft systems indicates that three of the major advantages of air cargo are rapid delivery, the ability to bridge geographical boundaries, and the capability to provide a flexible market response. The main disadvantage

is a higher transportation cost relative to surface modes. However, when other distribution elements are considered such as warehouse, inventory, and spoilage costs, the reduction in those factors associated with the air mode can often provide a net savings by air. Foreseeable advances in large aircraft development offer even greater profit potential by increasing the payload ton-miles per pound of fuel.

Air cargo demand is forecasted to increase in a dynamic manner with estimates of ton-mile growth varying from 11 to 16 percent per year between 1975 and 1985, the higher rate equating to an approximate fivefold increase (15 to 75 billion ton-miles). Stimulation of this demand will result from the development of advanced cargo systems incorporating both innovative and efficient cargo airplanes and dedicated cargo terminals. Consideration of future air cargo systems requirements is being pursued in Project INTACT (Intermodal Air Cargo Test), which is a privately funded joint venture involving over forty participants representing aircraft manufacturers, airlines, air forwarders, airports, DOT, and the Air Force. The community of Coalinga, California, is considering plans which would transform the city to a worldwide aerial trade center, exporting produce from the fertile San Joaquin Valley.

Preliminary NASA and industry studies indicate that large gains in aircraft payload and fuel efficiencies and reductions in development and operational costs are possible from the development and application of innovative advanced technologies and configuration concepts. NASA, in cooperation with elements of DOD and DOT, has work under way and has defined a Very Large Aircraft Systems Technology Program which includes systems studies, research and technology investigations, and a determination of the need for critical flight experiments.

The outlook for Air Cargo Aircraft of the future appears bright and the extensive R&T activity required to realize the forecasted potential has begun.

REFERENCES

1. Handbook of Airline Statistics - 1973 Edition, Civil Aeronautics Board.
2. Jackson, Richard M.: Important Aspects of International Air Cargo. Astronautics and Aeronautics, April 1975, pp. 50-53.
3. Aschenbeck, Lloyd B.: Air Freighters of the Future. Douglas Aircraft Company, Third Intersociety Conference on Transportation, Atlanta, Georgia, July 14-18, 1975.
4. Herron, D. P.: Expanding Air Freight Horizons by Use of the Air Freight Probability Factor. Conference Proceedings of the Seventh International Forum for Air Cargo, October 1-3, 1974.
5. Farris, Edsel S.: The C-14 as a Transportation Link in Developing Nations. Boeing Aerospace Company, Third Intersociety Conference on Transportation, Atlanta, Georgia, July 14-18, 1975.
6. Smick, A. Edward: Cargo Handling: Needed - A Marketing Systems Approach. Trans World Airlines, Inc., Astronautics and Aeronautics, January 1970.
7. Goodmanson, L. T.; and Bower, G. N.: Cargo Aircraft - A Look Toward the Future. Exxon Air World, vol. 27, No. 3, 1975.
8. Sletmo, Gunnar K.: Air Freight: A Growth Industry with Problems. Columbia University, Columbia Journal of World Business, September-October 1971.
9. Goodmanson, Lloyd T.: Development of the Dedicated Air Freighter. Boeing Commercial Airplane Company, presentation to Third Intersociety Conference on Transportation, Atlanta, Georgia, July 18, 1975.
10. Aerospace Daily, November 23, 1973.
11. New Horizons II, U.S. Air Force (HQ/XO), June 1975.
12. Schneider, L. M.: The Future of the U. S. Domestic Air Freight Industry. Harvard University, 1973.
13. Jackson, Paul; and Breckenridge, William: Air Cargo Distribution, Gower Press Ltd., London, 1971.
14. Frost and Sullivan: The Air Cargo Market. Frost and Sullivan, Inc., New York, New York, December 1972.

PRECEDING PAGE BLANK NOT FILMED

15. Electronic Equipment - A Brief Total Cost of Distribution Analysis. ER 10517, The Lockheed-Georgia Company, June, 1969.
16. California Lettuce - A Brief Total Cost of Distribution Analysis. ER 10518, The Lockheed-Georgia Company, June, 1969.
17. Flying Tigers Fly 212 Cattle to Philippines: Western Livestock Journal, September 9, 1974.
18. Norris, John T.: The Facts About Project INTACT (Intermodal Air Cargo Test). Department of Transportation, October 1974.
19. Coalinga Cargo Port - West Side City's Leaders Launch Plans to Become Worldwide Aerial Trade Center. The Fresno Bee, April 24, 1975.
20. McNulty, J. J.: Intermodality and the Freight Forwarder. Proceedings of the Seventh International Forum for Air Cargo, October 1-3, 1974.
21. Air Cushion Vehicles, USSR; Jane's Surface Skimmers, 1974-75, pp. 120-121.
22. Dornier, C., Jr.: Considerations on the Future Tasks of the European Aeronautical Industry in the Field of Civil Aviation. L'Aeronautique et L'Astronautique, No. 51, 1975, pp. 2-13.
23. Lange, R. H.: Design Concepts for Future Cargo Aircraft. Lockheed-Georgia Company, AIAA Paper 75-306, AIAA 11th Annual Meeting and Technical Display, Washington, DC, February 24-26, 1975.
24. Whitehead, A. H., Jr.: Preliminary Analysis of the Span-Distributed Load Concept for Cargo Aircraft Design. NASA Langley Research Center, NASA TM X-3319, 1976.
25. Whitehead, A. H., Jr.: Perspective on the Span-Distributed Load Concept for Application to Large Cargo Aircraft Design. NASA Langley Research Center, NASA TM X-3320, 1976.
26. Levin, Stuart M.: Uncompromised Cargo - the Mach .9 Box. Space/Aeronautics, October 1969, pp. 34-44.
27. Heldenfels, R. R.: Recent NASA Progress in Composites. NASA Langley Research Center, NASA TM X-72713.
28. Pierpont, P. Kenneth: Bringing Wings of Change. NASA Langley Research Center, Astronautics and Aeronautics, October 1975.
29. Whitcomb, Richard T.: Review of NASA Supercritical Airfoils. Paper No. 74-10, The Ninth Congress of the International Council of the Aeronautical Sciences, Haifa, Israel, August 1974.

30. Kurzhals, Peter R.: NASA Advanced Control Technology: An Overview. Presented at the NASA Symposium on Advanced Control Technology and Its Potential for Future Transport Aircraft, Los Angeles, California, July 9-11, 1974.
31. Nagel, A. L.; and Alford, W. J., Jr., Langley Research Center; and Dugan, J. F., Jr., Lewis Research Center: Future Long-Range Transports-Prospects for Improved Fuel Efficiency. Presented at the AIAA 11th Annual Meeting and Technical Display, Washington, D.C., February 24-26, 1975.
32. Thompson, William C.: Landing Performance of An Air-Cushion Landing System Installed on a 1/10-Scale Dynamic Model of the C-8 Buffalo Airplane. Langley Research Center, NASA TN D-7295, September 1973.
33. Leland, Trafford J. W.; and Thompson, William C.: Landing-Impact Studies of a 0.3-Scale Model Air Cushion Landing System for a Navy Fighter Airplane. Langley Research Center, NASA TN D-7875, March 1975.

U.S.-EUROPEAN TRADE - 1973

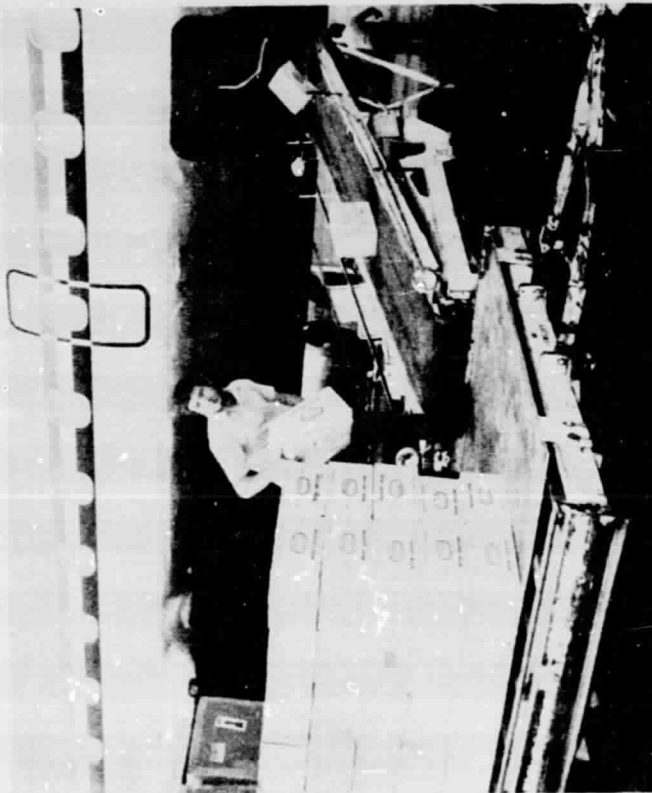
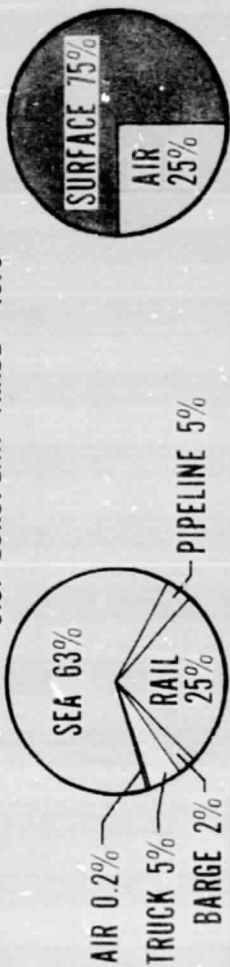

Figure 1. - Some aspects of current air cargo environment

PRECEDING PAGE BLANK NOT FILMED

RAPID DELIVERY

BLOCK SPEED,
MILES/HOUR



500

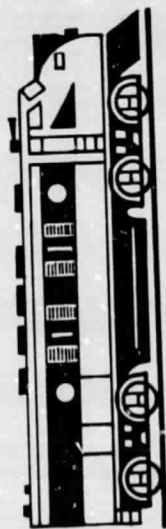

20

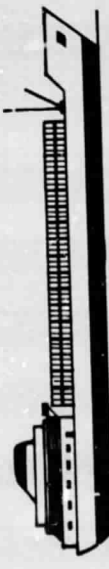

20



40

NO GEOGRAPHICAL BARRIERS

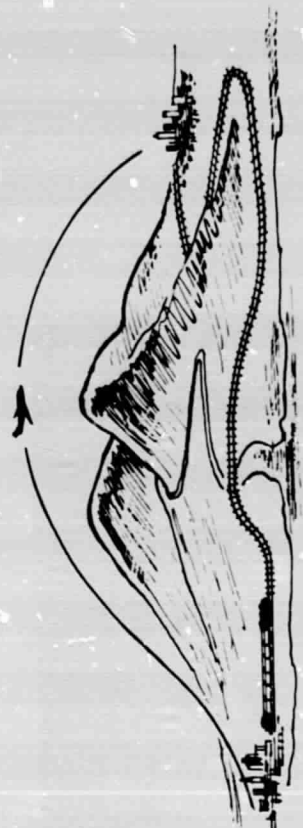

FLEXIBLE MARKET RESPONSE

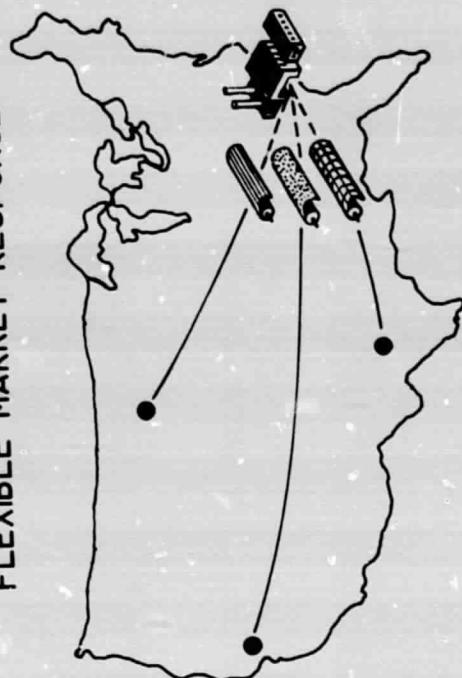

Figure 2. - Advantages of air cargo

NEW MARKET OBJECTIVE

- 16% GROWTH FROM 1975
- ADDITIONAL TRAFFIC EQUIVALENT TO 240 747 F'S IN 1985

CURRENT MARKET

- 11% GROWTH FROM 1975

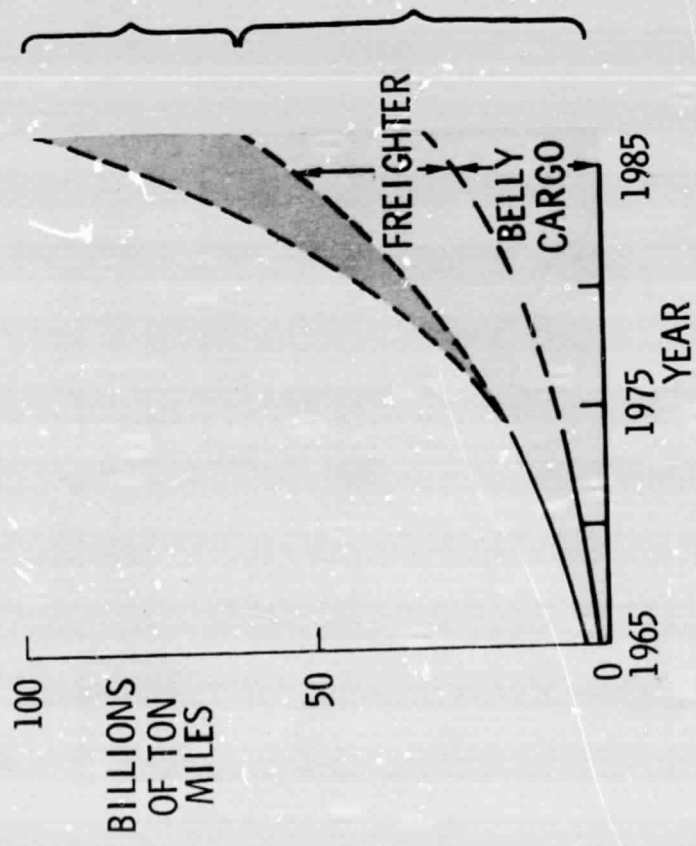
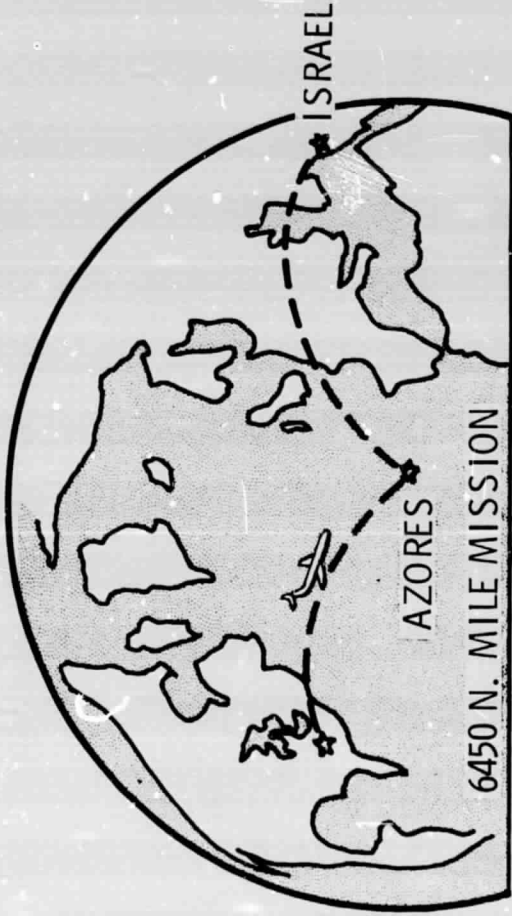

Figure 3. - History and forecast of air cargo growth



421 MISSIONS WITH C-141..... 11 500 TONS
 145 MISSIONS WITH C-5 10800 TONS
 33 DAYS TO TRANSPORT..... 22300 TONS



PALLETS
 CONTAINING AMMUNITION,
 MISSILES, ELECTRONICS, ETC.



CH-53
 (23 000 lb)

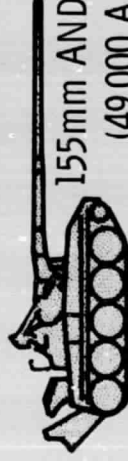

155mm AND 175mm CANNON
 (49 000 AND 56 000 lb)

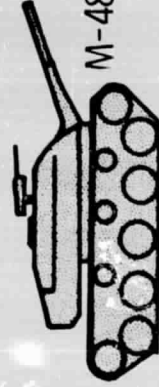

M-48 AND M-60 TANKS
 (100 000 lb)

Figure 4. - The USAF 1973 resupply to Israel illustrating military airlift requirements.

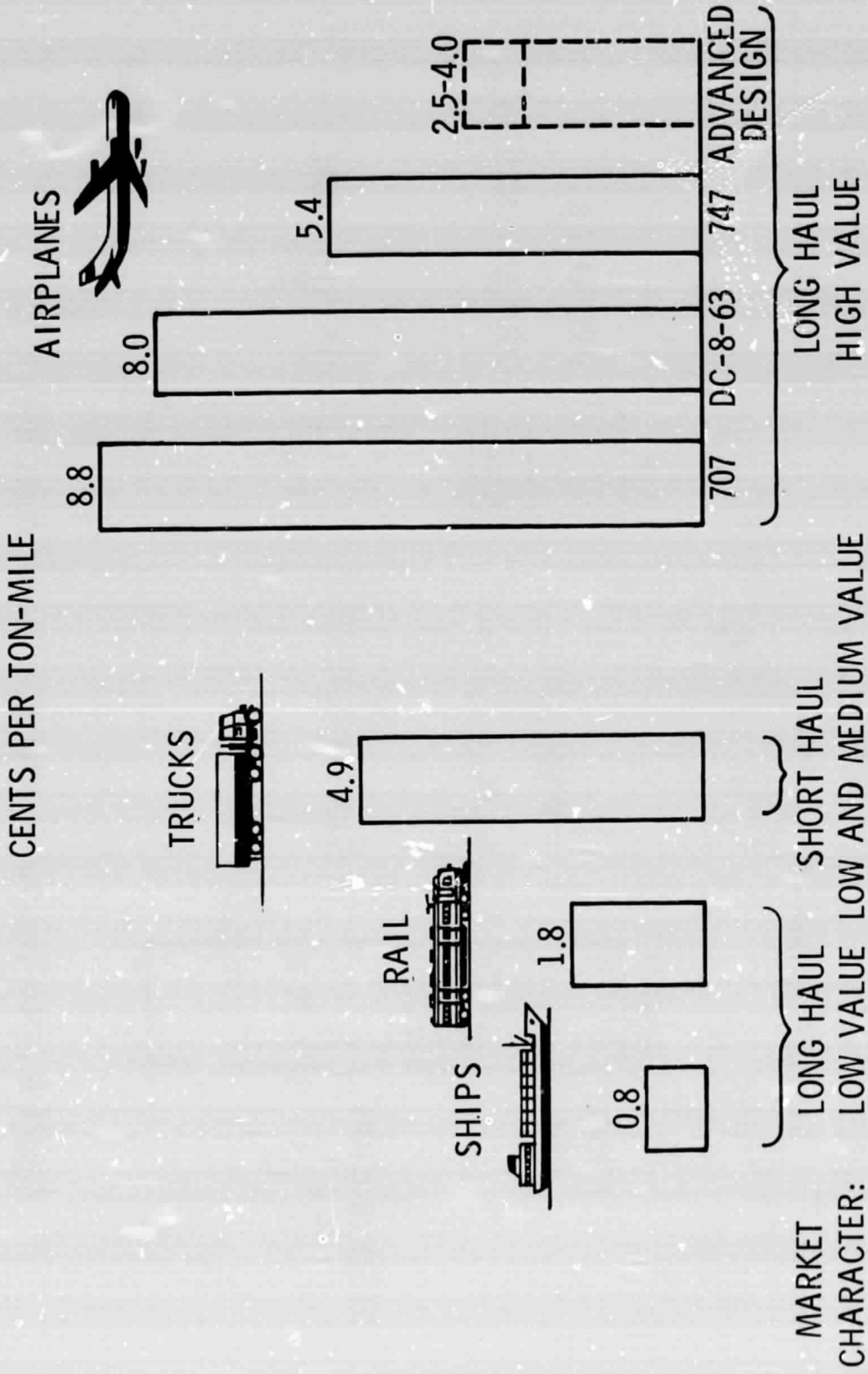

Figure 5. - Comparison of operating costs and market characteristics for various transportation modes.

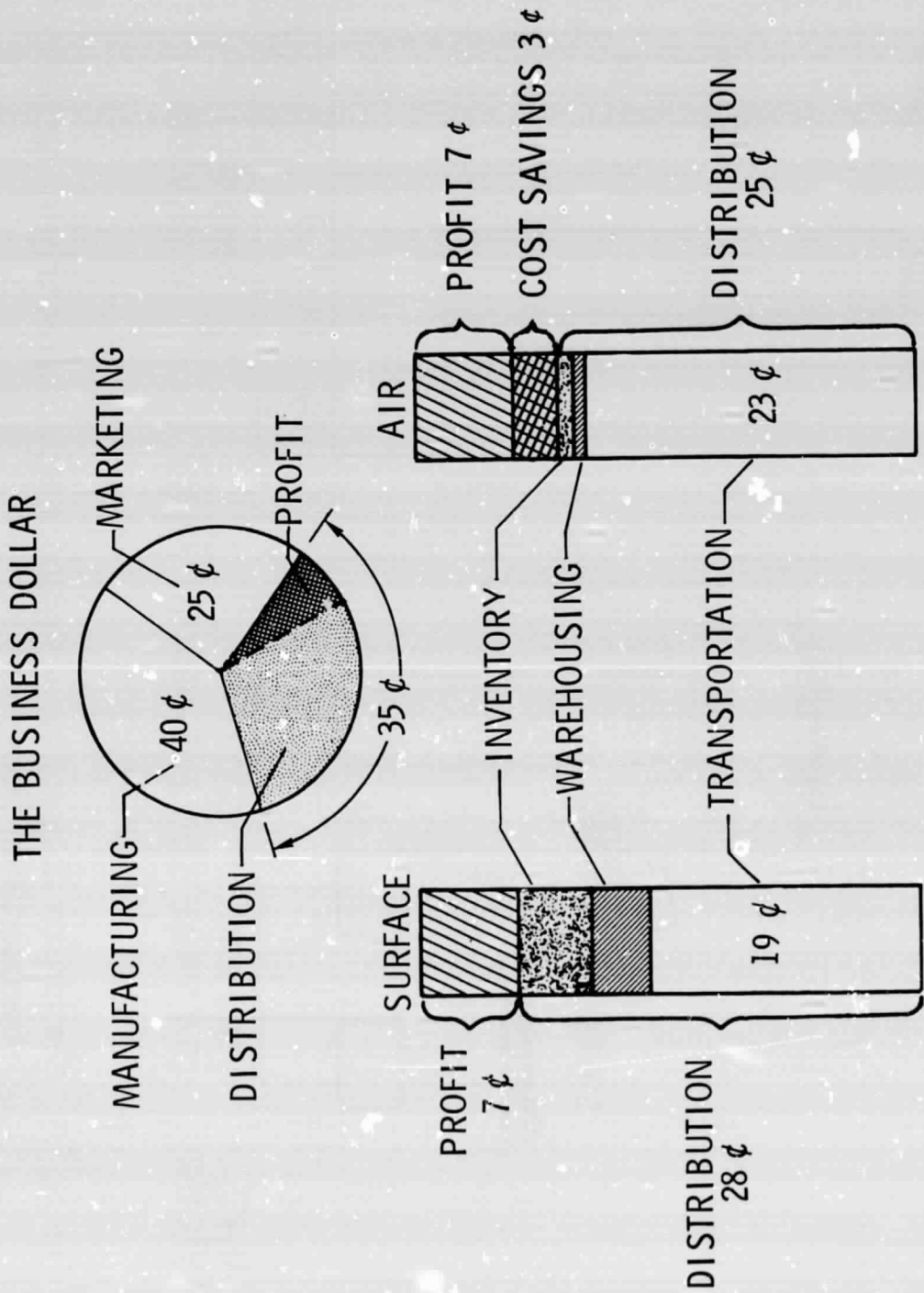

Figure 6. - The concept of total distribution costs (typical of the appliance industry)

FIVE U. S. TRUNK CARRIERS

| RANK | COMMODITY | GROSS FREIGHT REVENUE (\$ MILLIONS) | % OF TOTAL |
|------|--|--|------------|
| 1 | WEARING APPAREL | 22.3 | 6.6 |
| 2 | ELECTRONIC AND ELEC. EQUIPMENT; APPLIANCES | 19.7 | 5.8 |
| 3 | MACHINERY AND PARTS | 18.0 | 5.3 |
| 4 | PRINTED MATTER | 16.4 | 4.8 |
| 5 | CUT FLOWERS, NURSERY STOCK, HORTICULTURE | 10.7 | 3.2 |
| 6 | AUTO PARTS AND ACCESSORIES | 9.7 | 2.9 |
| 7 | PHONOGRAPH RECORDS, TAPES, TV, RADIOS | 9.3 | 2.7 |
| 8 | FRUITS AND VEGETABLES | 7.2 | 2.1 |
| 9 | BAGGAGE AND PERSONAL EFFECTS | 6.3 | 1.9 |
| 10 | RETAIL PRODUCTS | <u>5.2</u> | <u>1.5</u> |
| | SUBTOTAL | 124.8 | 36.8 |
| | TOTAL FOR ALL SHIPMENTS | 339.6 | |

Figure 7. - Ranking of top-ten air freight commodities (1971).

CURRENT SYSTEM

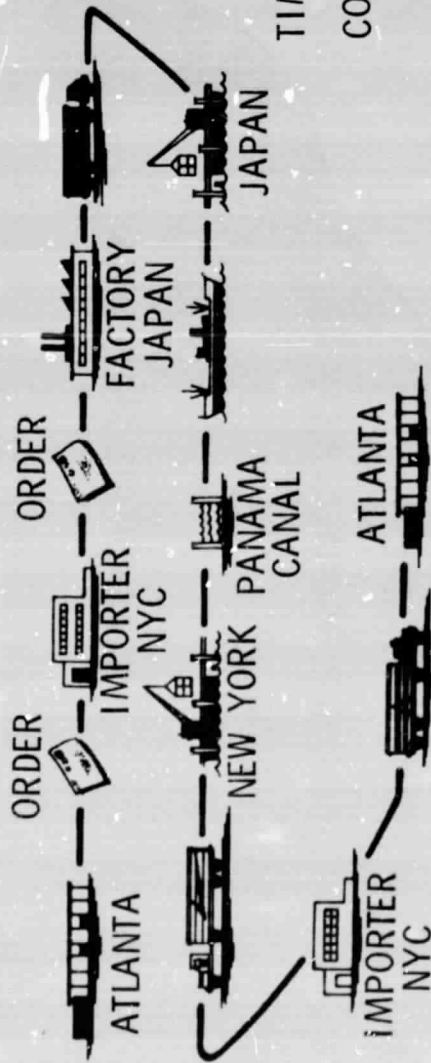

| | CURRENT SYSTEM | AIR CARGO SYSTEM |
|------------|----------------|------------------|
| TIME, days | 100 | 4 |
| COST/UNIT | \$52 | \$36 |

AIR MODE PROVIDES A
2500% TIME SAVINGS
AND A 30% NET COST
SAVINGS

AIR CARGO SYSTEM

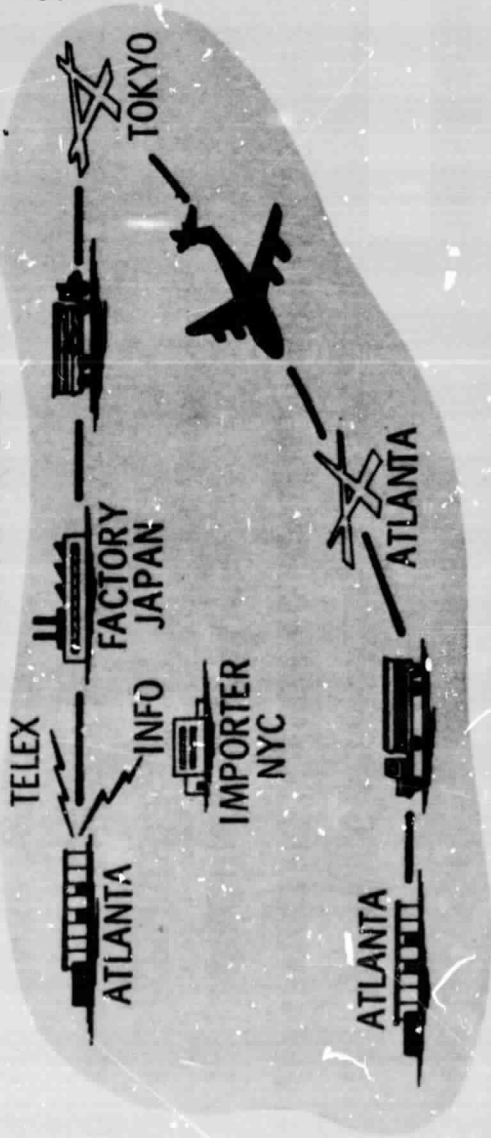

Figure 8. - Transportation of TV sets from Japan to Atlanta - air vs. surface mode

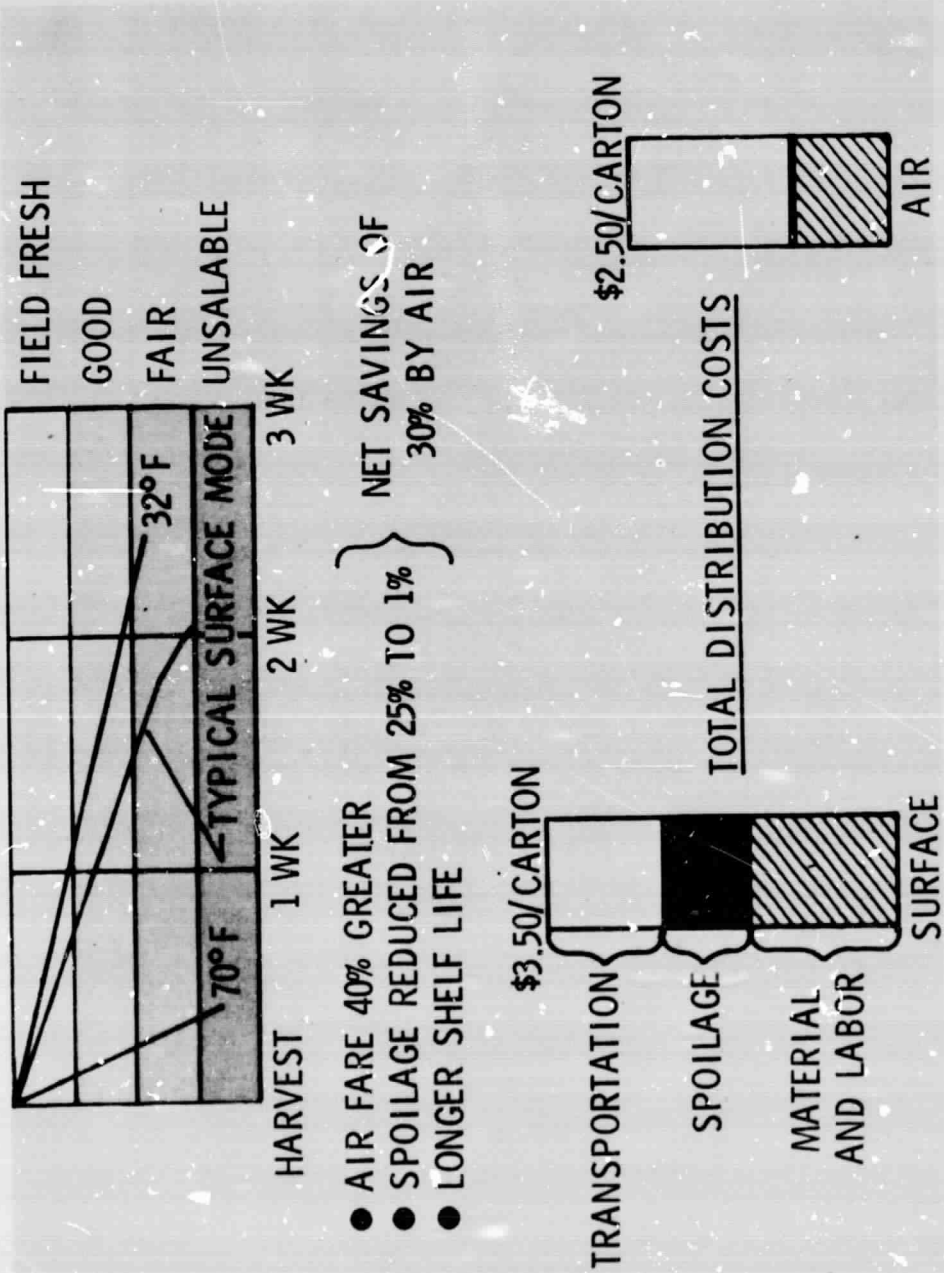

Figure 9. Transportation of California lettuce to East Coast - air vs. surface mode



Figure 10. - Photograph of livestock aboard Flying-Tiger DC-8 freighter

ORIGINAL PAGE IS
OF POOR QUALITY

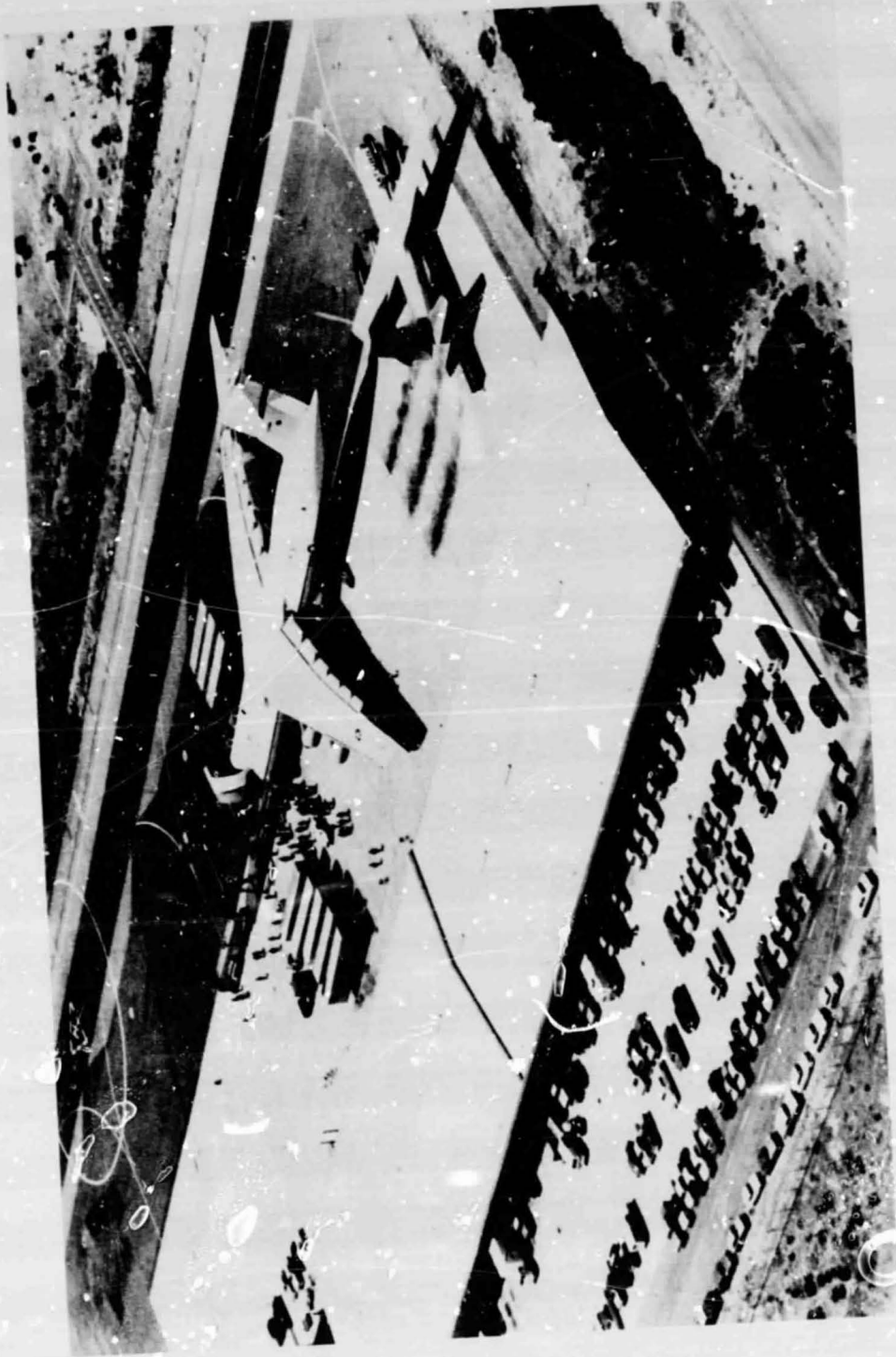

Figure II. - Aerial photograph of Lockheed C-5A being loaded during project "INTACT" demonstration at Oakland International Airport

ORIGINAL PAGE IS
OF POOR QUALITY

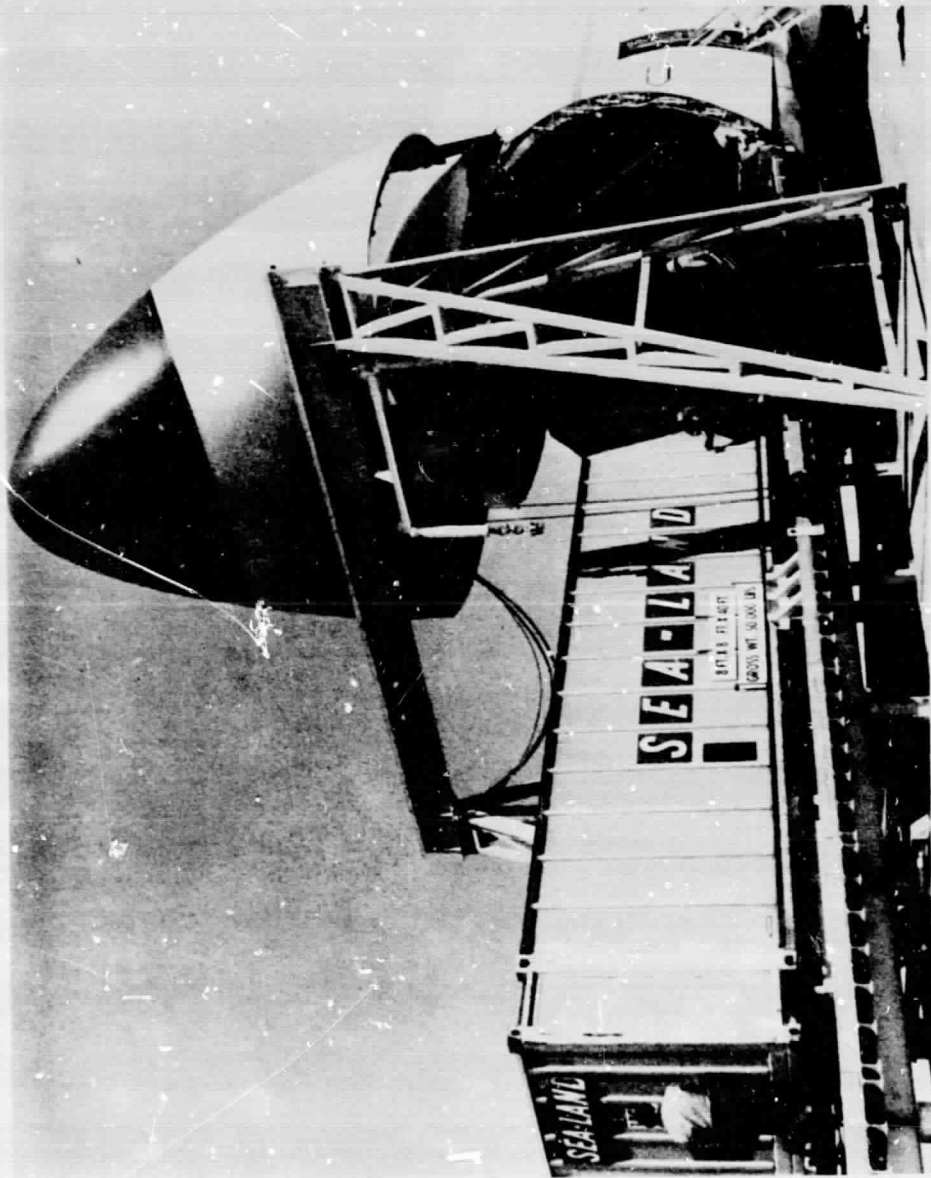

Figure 12. - Close-up photograph of 50,000 pound container moving into Lockheed C-5A on air-bearing shuttle during project "INTACT" demonstration.

FRESNO BEE April 24, 1975

Coalinga Cargo Port

West Side City's Leaders Launch Plans To Become Worldwide Aerial Trade Center

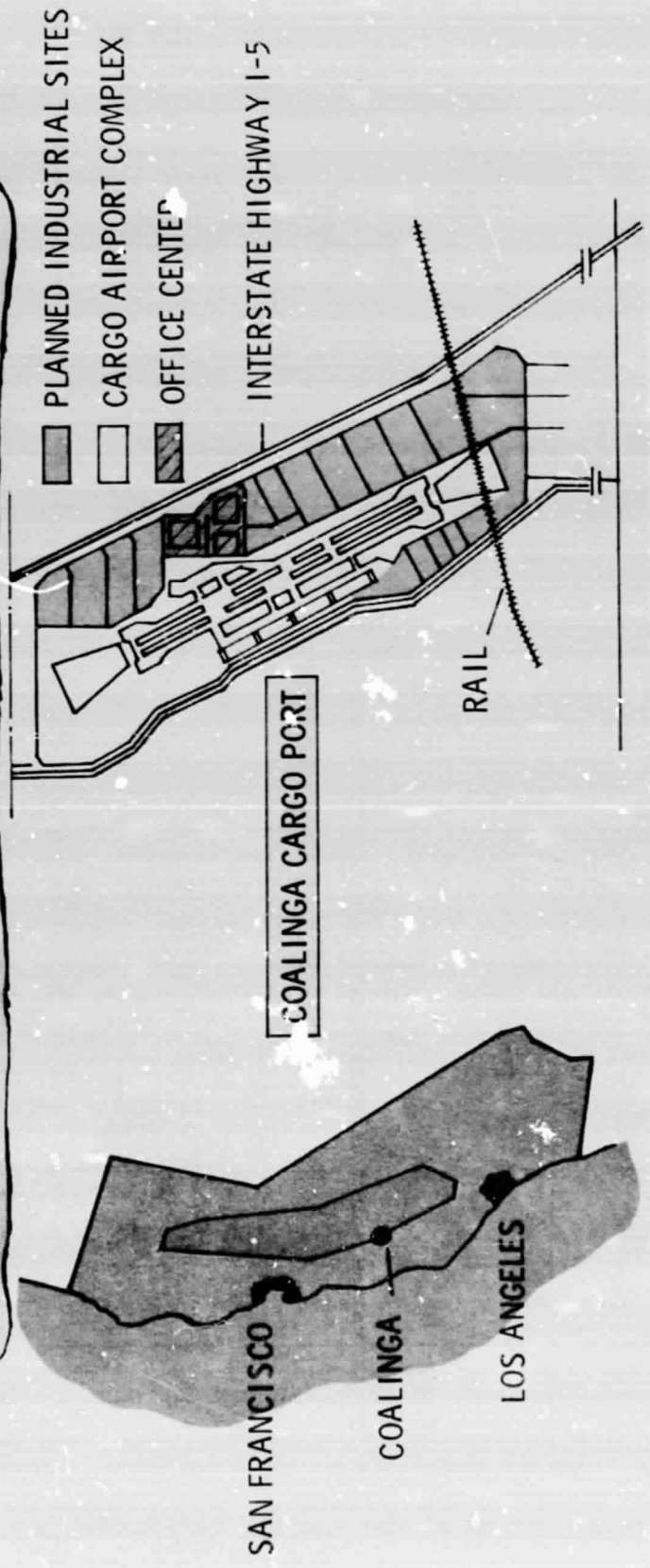

Figure 13. - Illustration of future cargo-port planning.

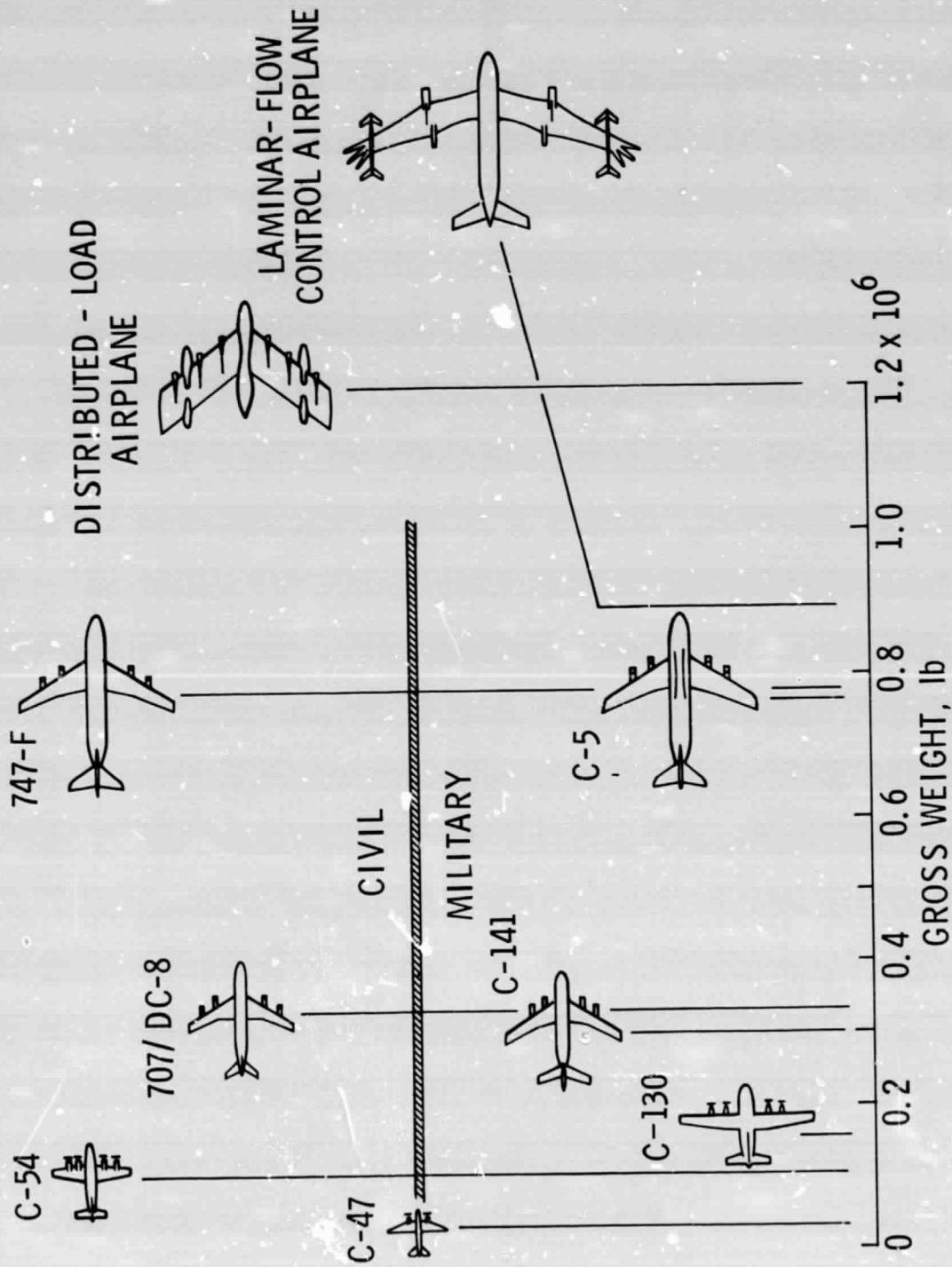

Figure 14. - Key aircraft in the evolution of air freighter design.

$\frac{\text{ton} - \text{n. mi.}}{\text{lb of fuel}}$ = f(SPEED, L/D, PAYLOAD FRACTION, OPERATING WEIGHT FRACTION, SFC)

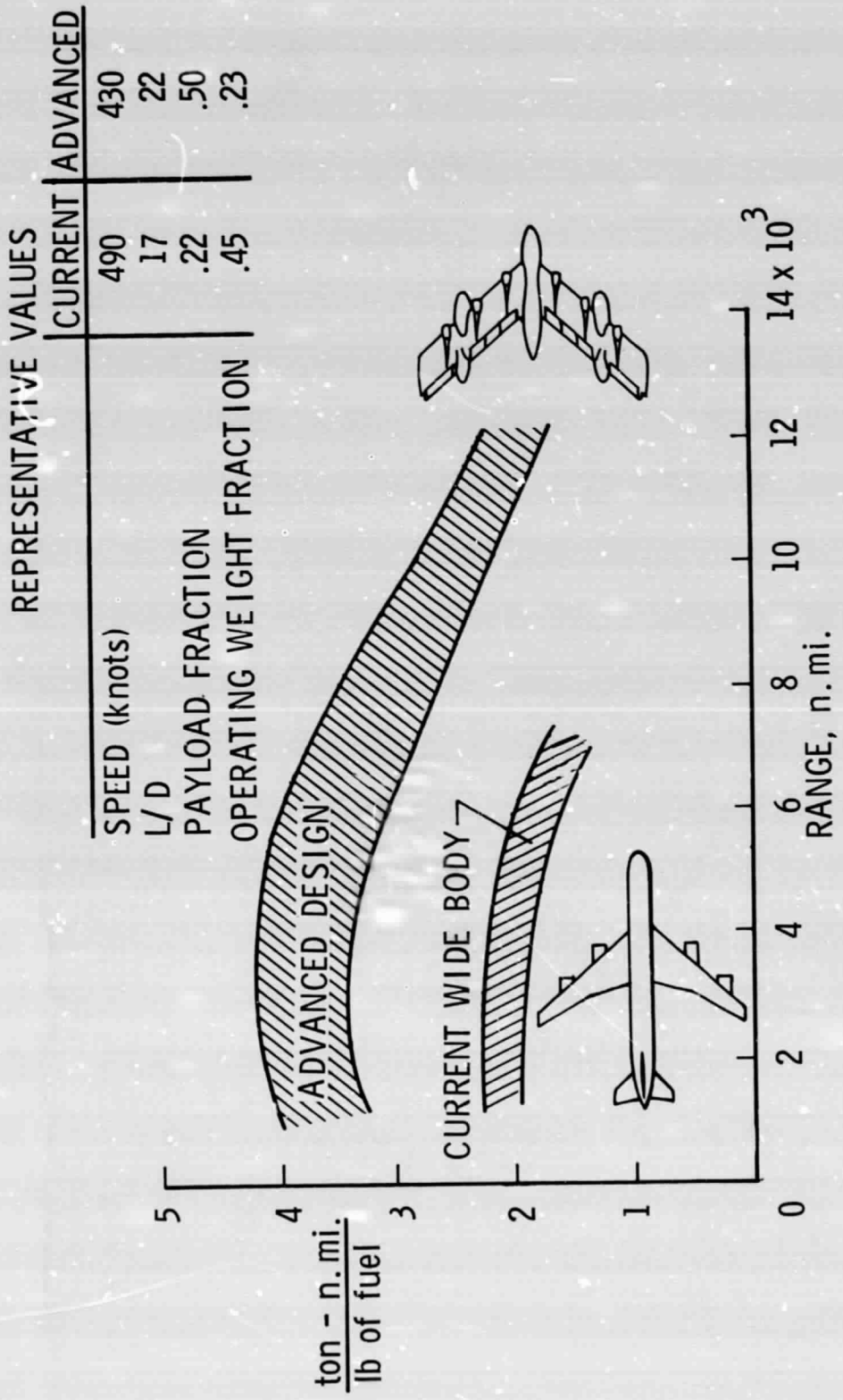
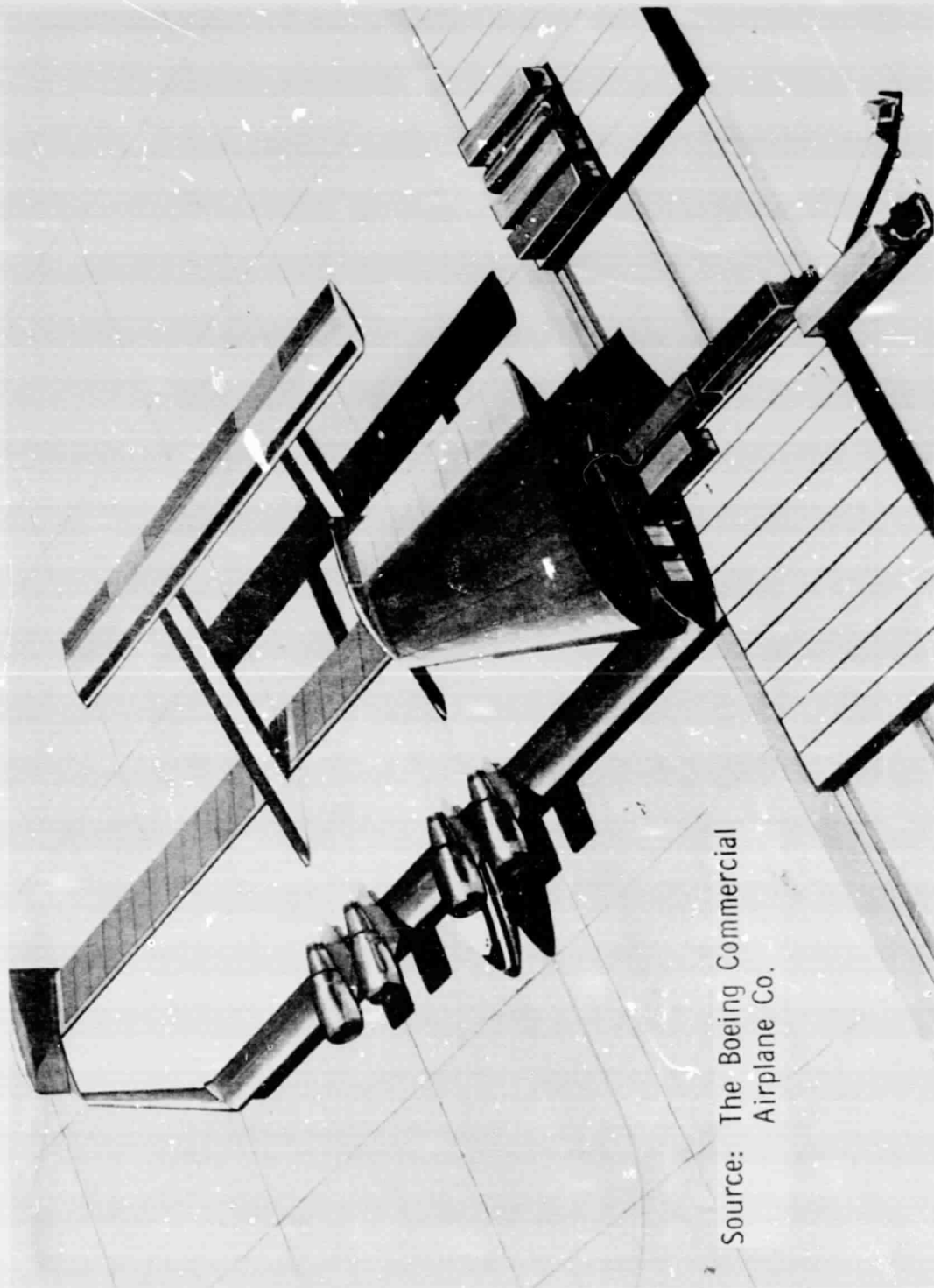

Figure 15. - Comparison of payload and fuel efficiency of current and advanced air cargo concepts.



Source: The Boeing Commercial Airplane Co.

Figure 16. - Illustration of multimission freighter concept

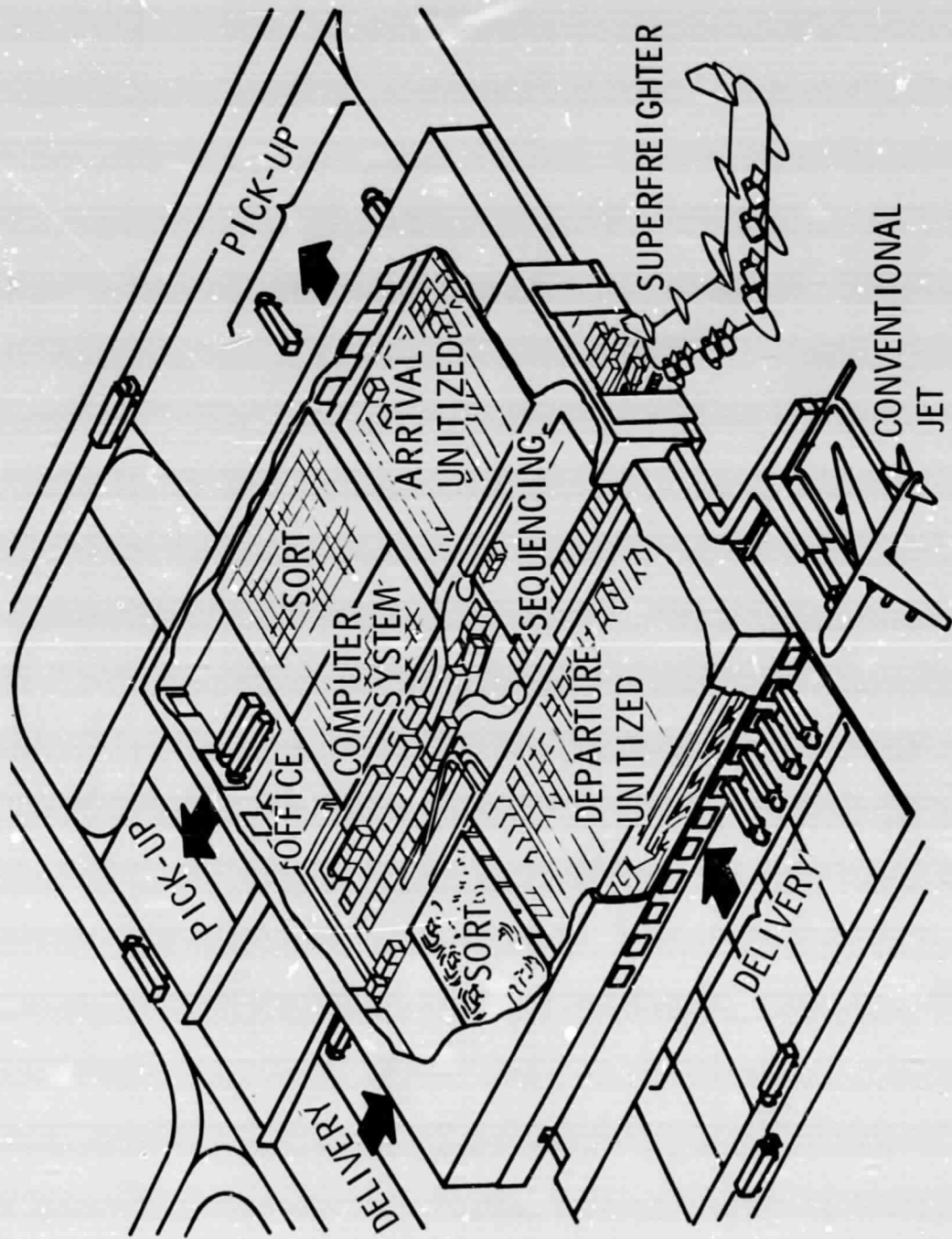

Figure 17 - Conceptual illustration of a future air cargo terminal area system

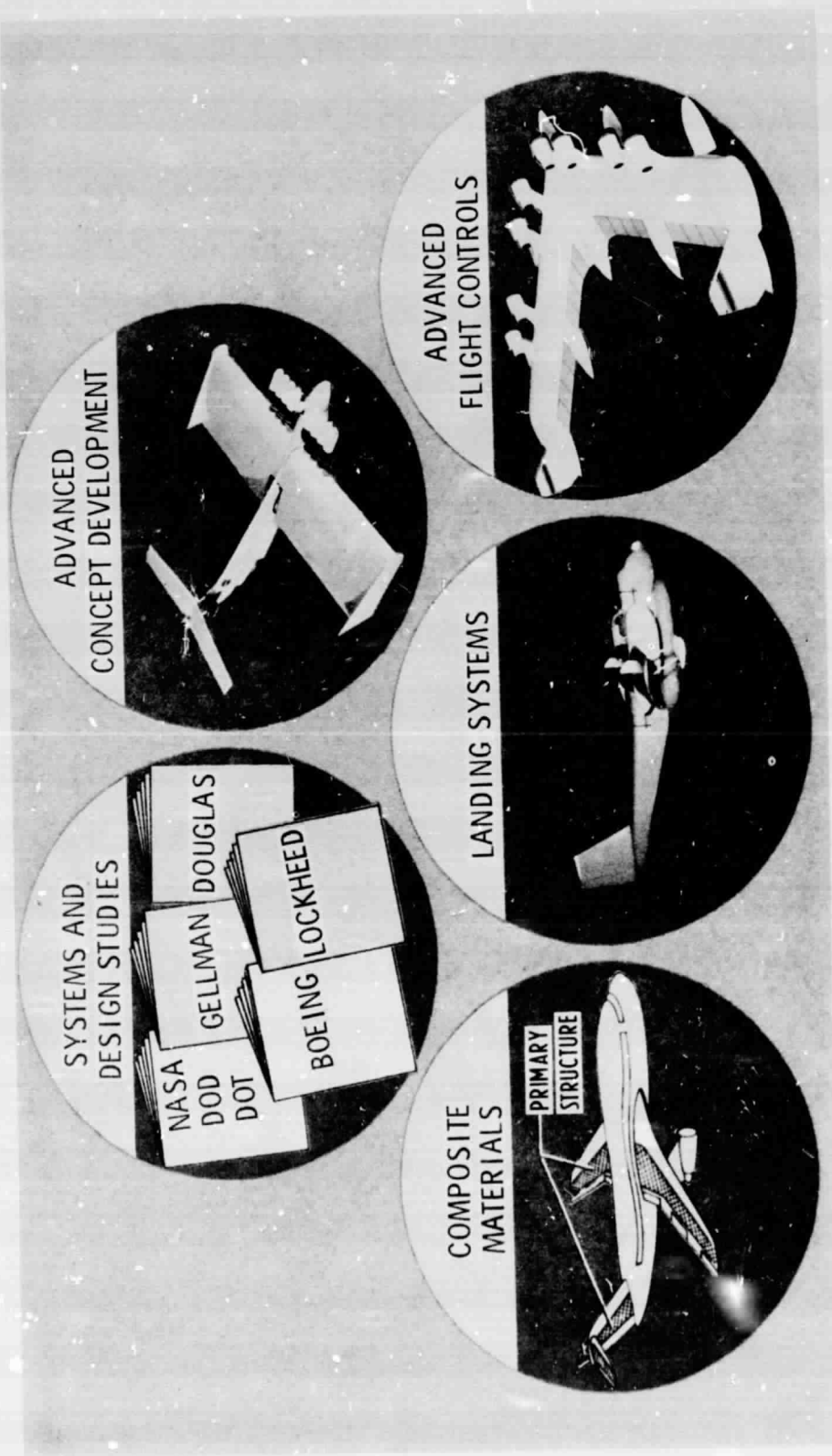

Figure 18. - Representative elements of NASA proposed Very Large Aircraft Systems Technology Program (in cooperation with DOD and DOT).

ORIGINAL PAGE IS
OF POOR QUALITY

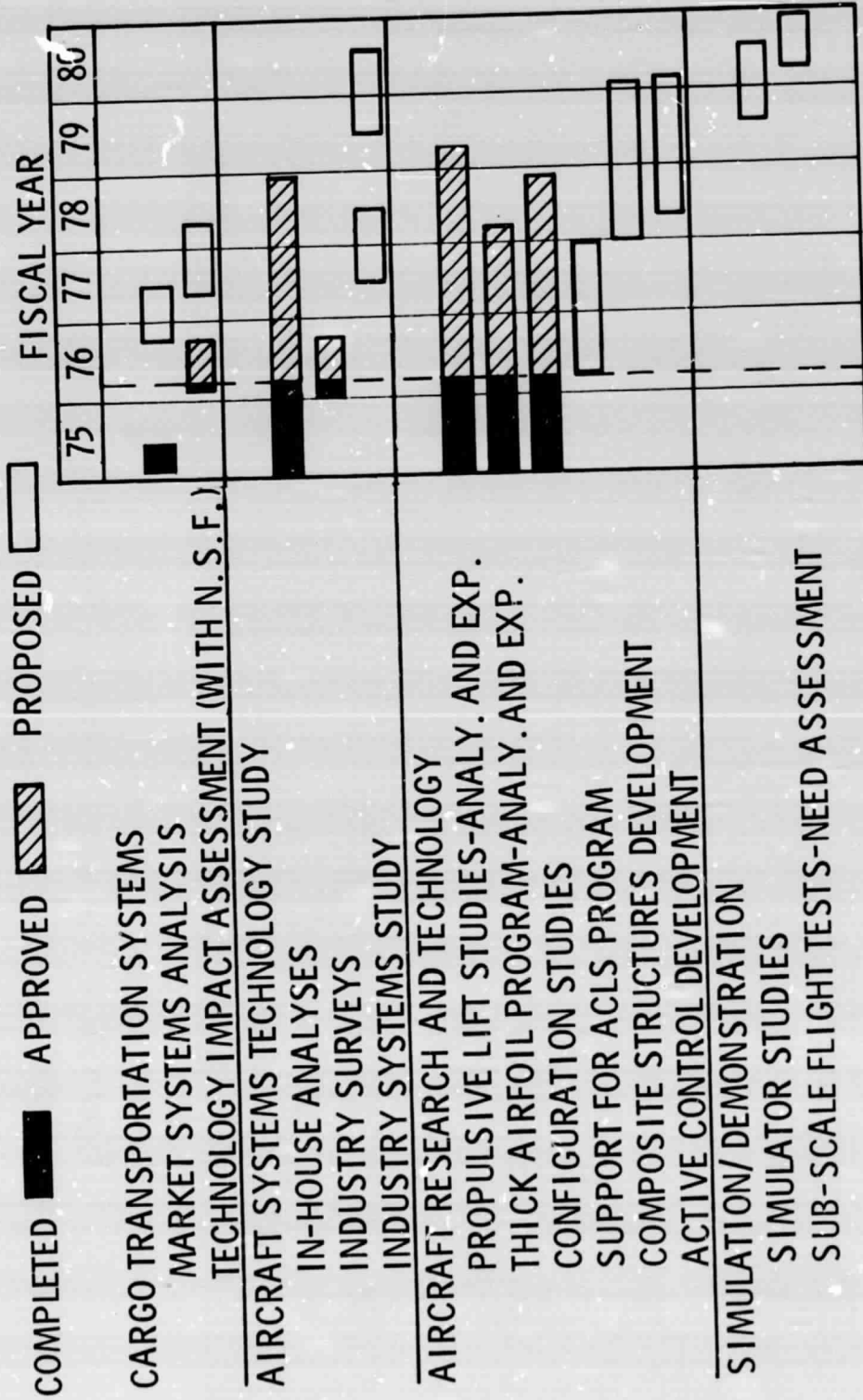

Figure 19. - Representative elements and milestones of NASA proposed Very Large Aircraft Systems Technology Program (in cooperation with D. O. D. and D. O. T.)

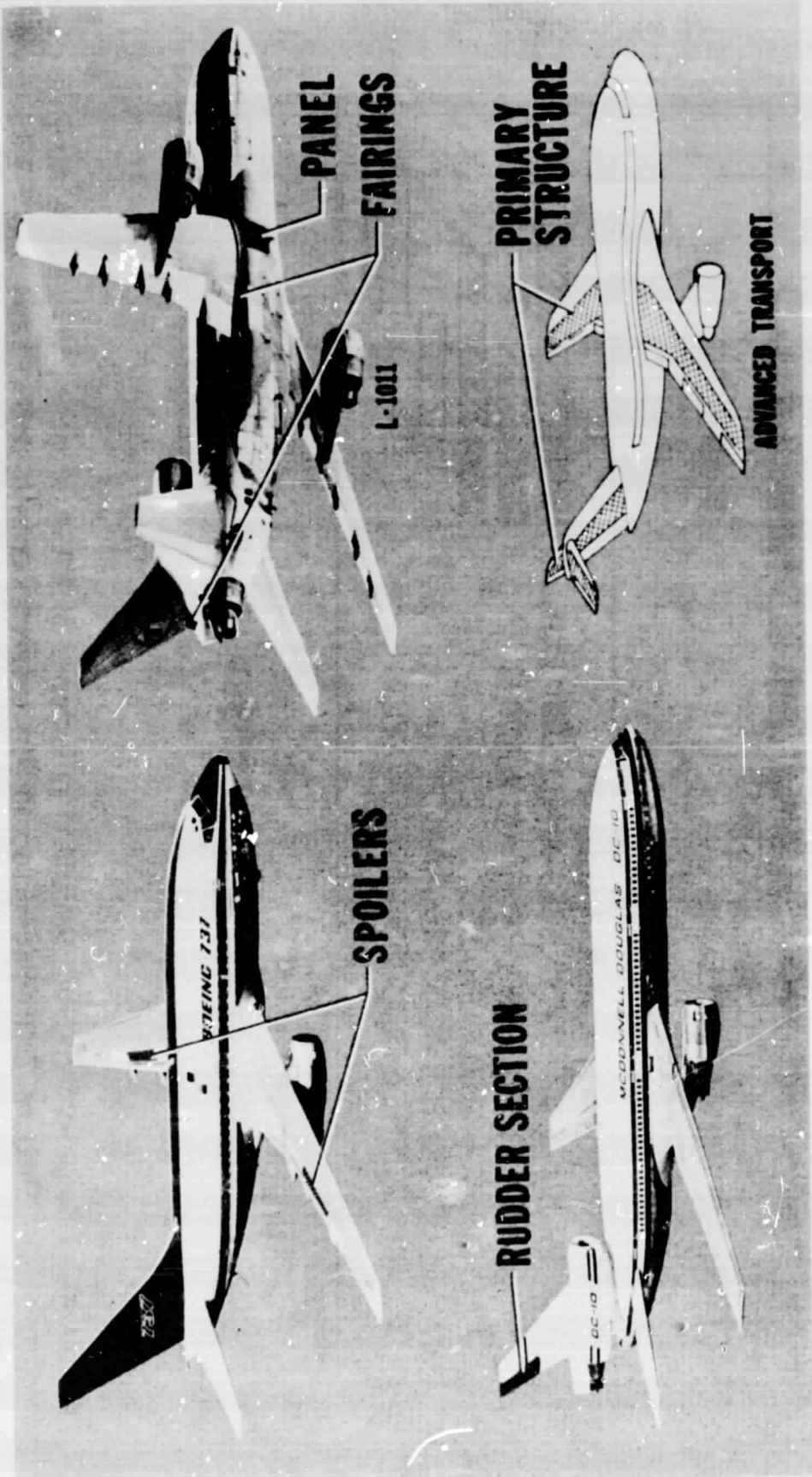

Figure 20. - The NASA Advanced Composites Program.

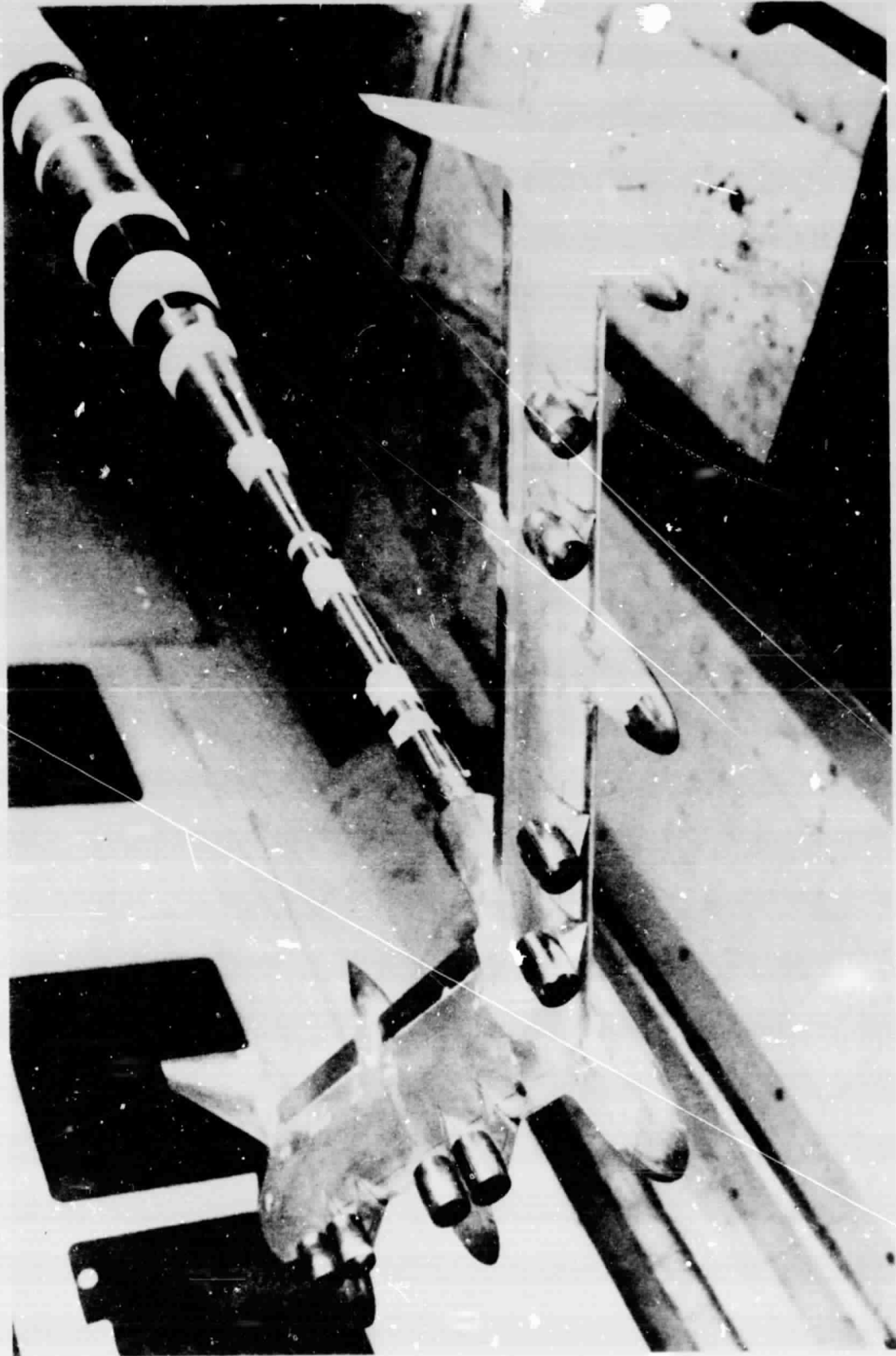

Figure 21. - Photograph of advanced distributed-load aircraft model mounted in Langley High-Speed 7-by-10-Foot Wind-Tunnel.

ORIGINAL PAGE IS
OF POOR QUALITY

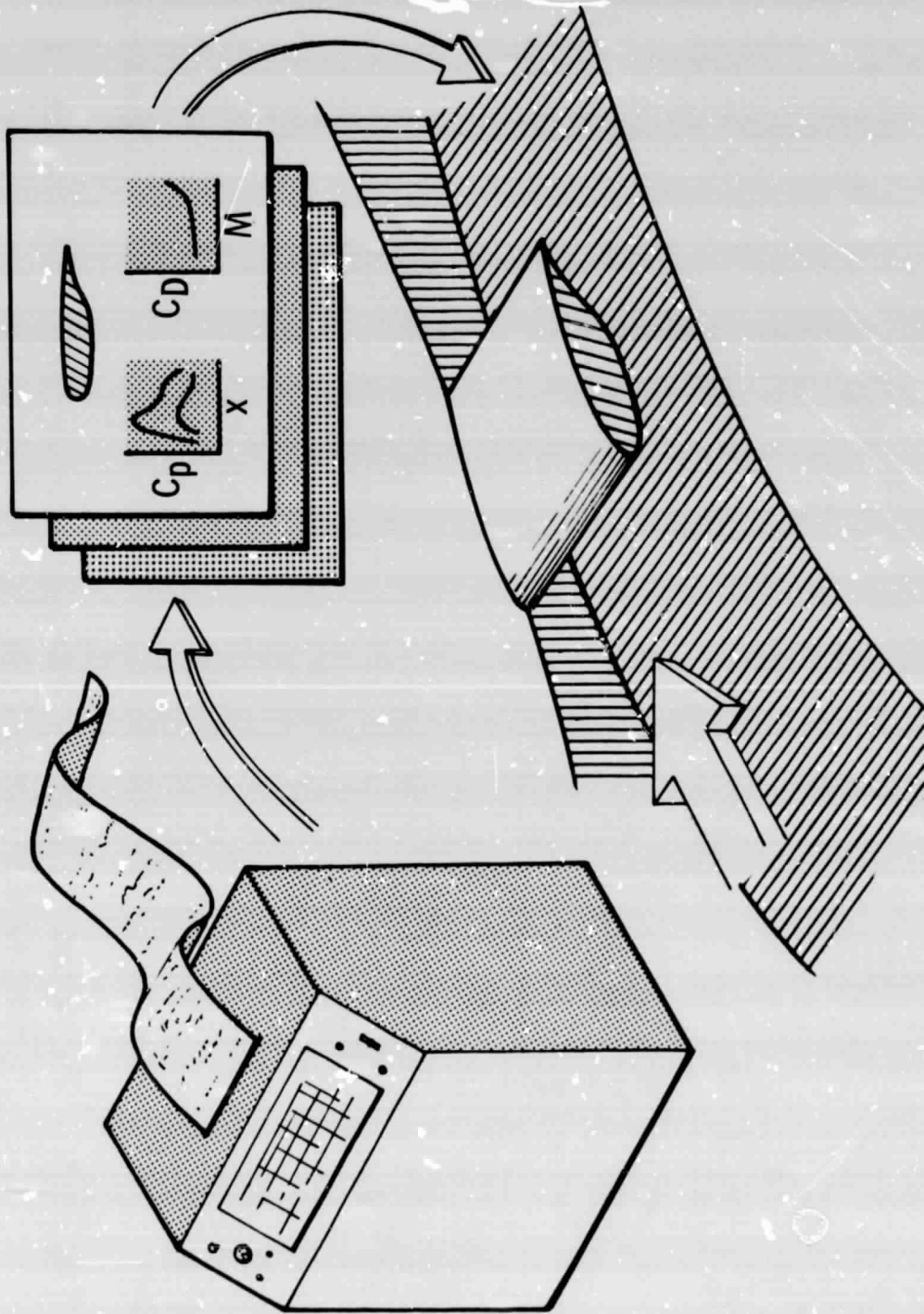

Figure 22. - Illustration of advanced airfoil development process.

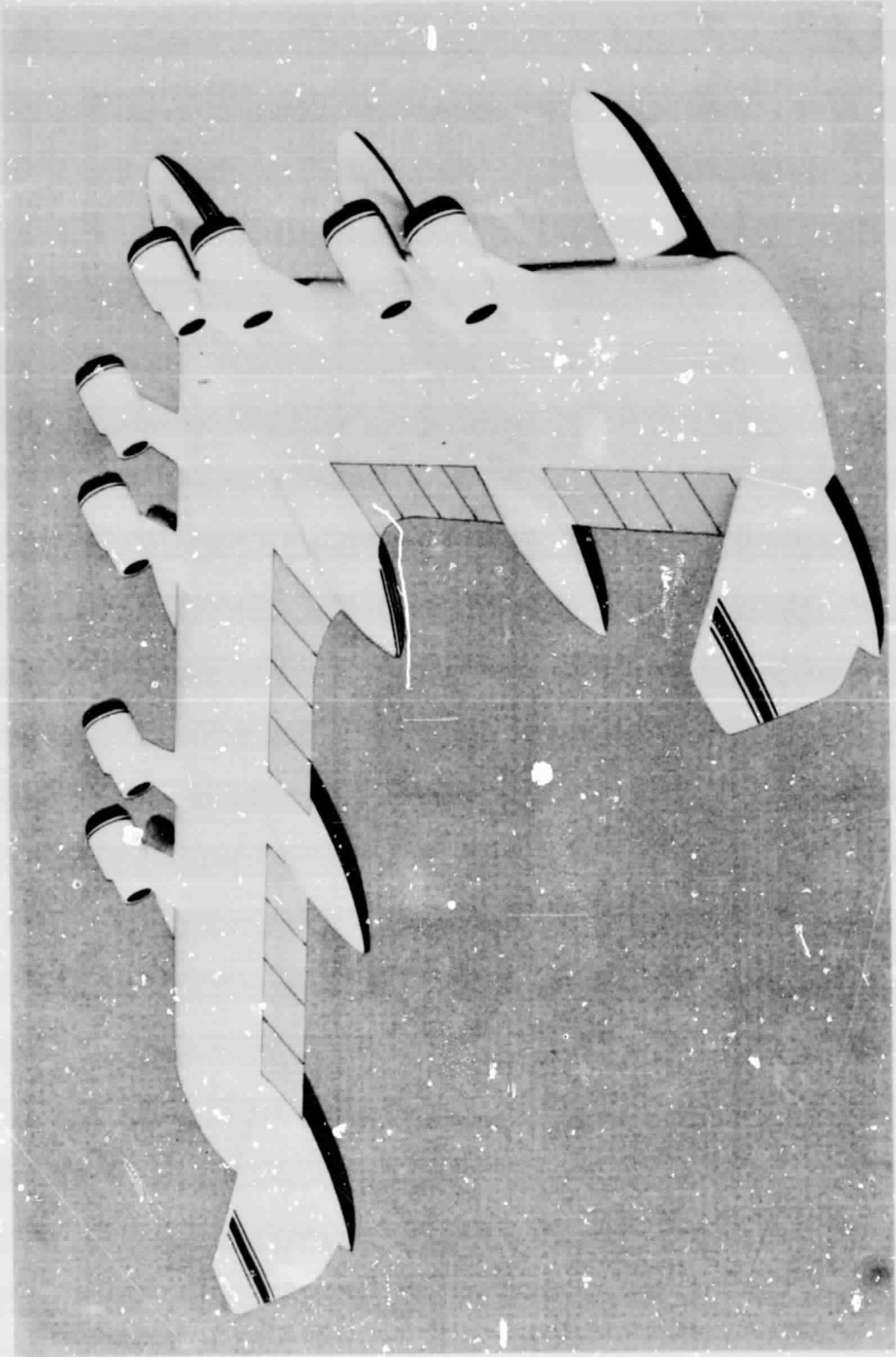

Figure 23. - Illustration of control surfaces being considered in advanced active control technology studies

ORIGINAL PAGE IS
OF POOR QUALITY



CONVENTIONAL



AIR CUSHION

Figure 24. - Illustration of potential landing systems for large distributed-load aircraft concepts.

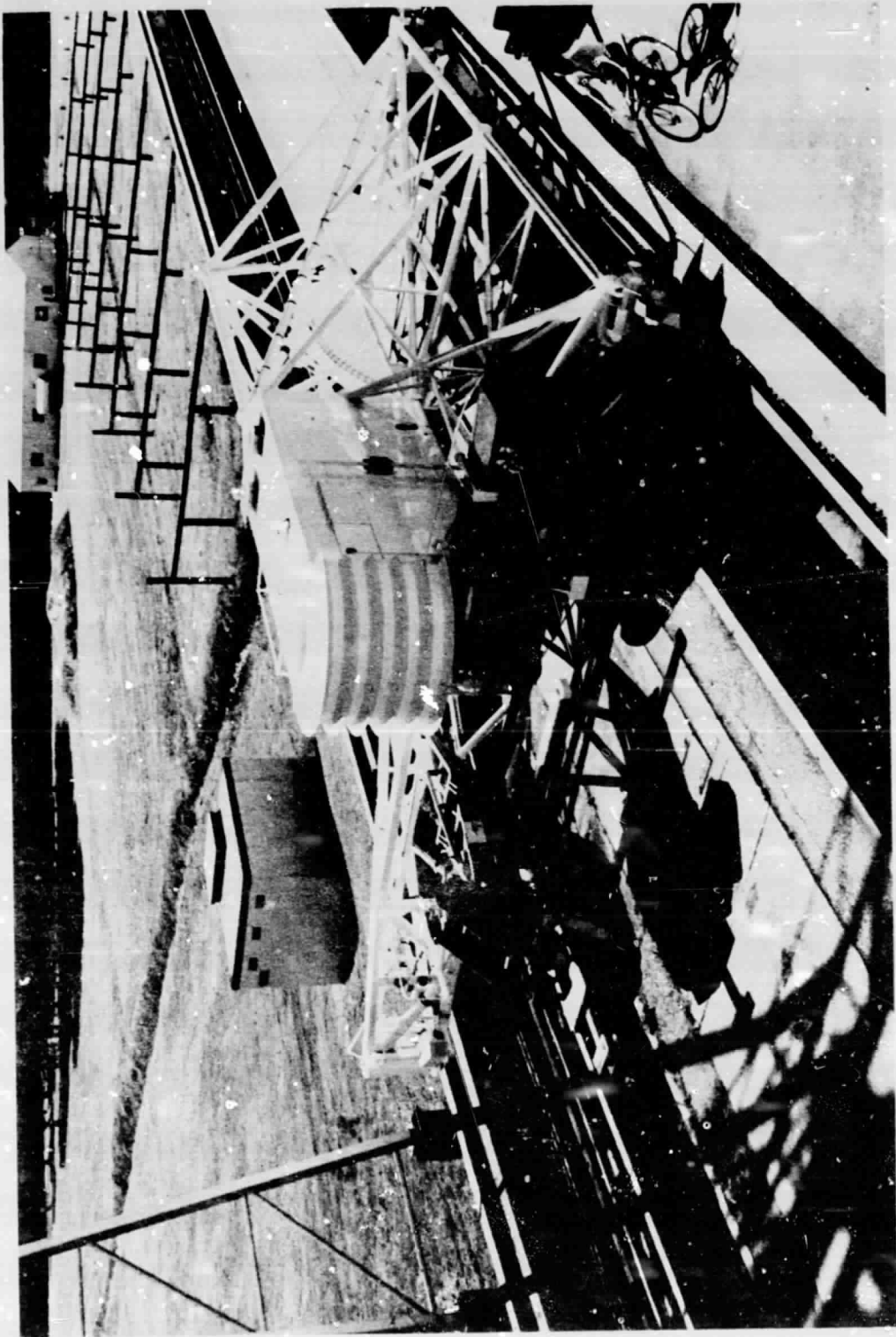

Figure 25. - Photograph of air-cushion landing system installed in Langley Landing Loads Track.

ORIGINAL PAGE IS
OF POOR QUALITY

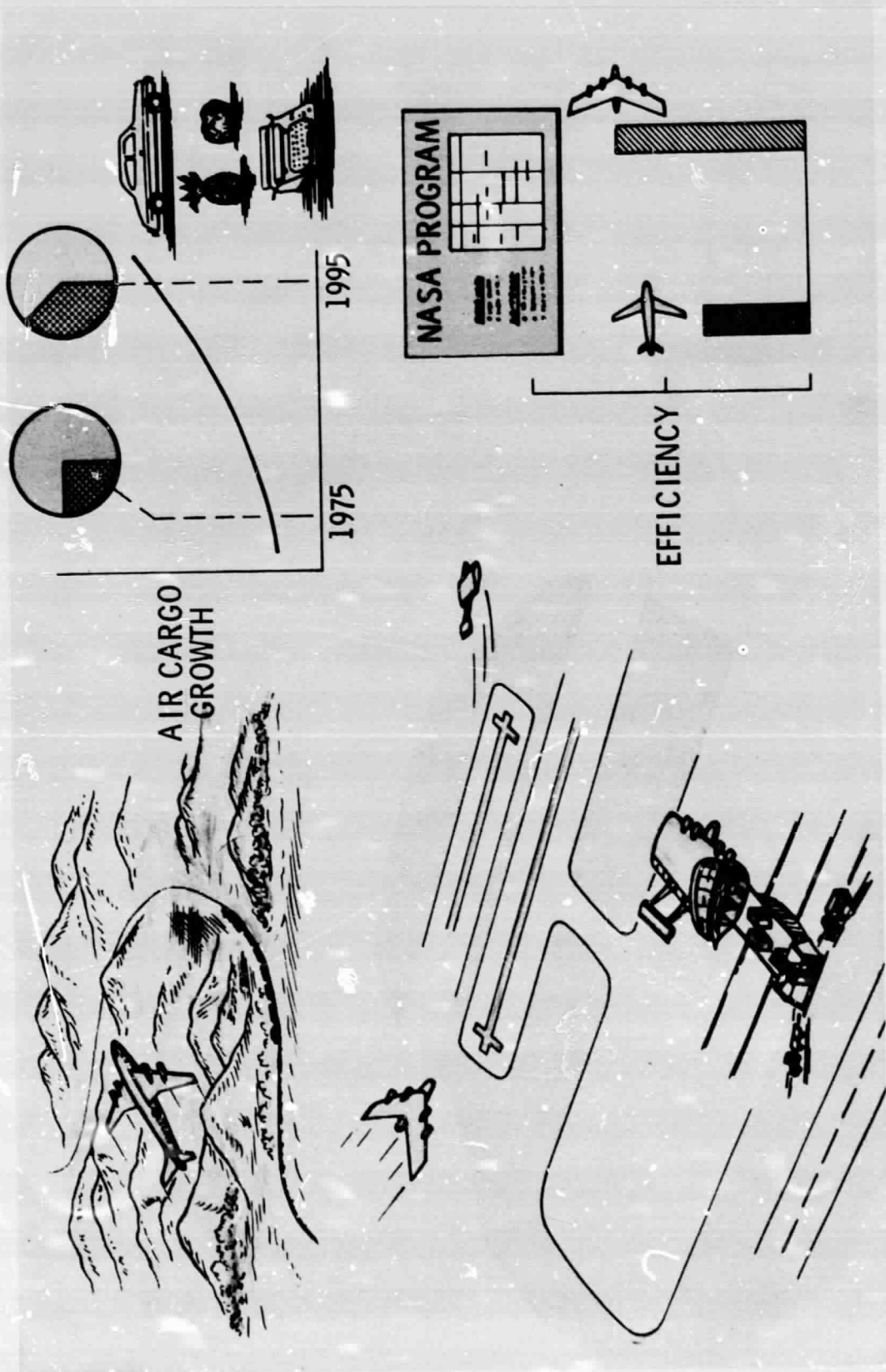

Figure 26 - Summary of some key elements required to develop future air cargo systems.