

DTCO-19190-1

CONTRACT NAS8-30745

DCN 1-4-50-42562(2F)

(NASA-CR-144082)	SHUTTLE LOX LOADING	N76-13151
TRANSIENT STUDY	Final Report (Boeing	
Aerospace Co., Huntsville, Ala.)	93 F HC	
\$5.00	CSCI 22D	Unclas
	G3/14	05333

FINAL REPORT

SHUTTLE LOX LOADING TRANSIENT STUDY

PREPARED BY
V. L. GLASGOW

BOEING AEROSPACE COMPANY
(A DIVISION OF THE BOEING COMPANY)
HUNTSVILLE, ALABAMA

C. R. CARTER - PROJECT SUPERVISOR

DECEMBER 1, 1975



PREPARED FOR
NATIONAL AERONAUTICS AND SPACE ADMINISTRATION
GEORGE C. MARSHALL SPACE FLIGHT CENTER
HUNTSVILLE, ALABAMA

D180-19190-1

TABLE OF CONTENTS

<u>SECTION</u>		<u>PAGE</u>
	CONTENTS	ii
	ACKNOWLEDGEMENTS	iii
1.0	INTRODUCTION	1-1
2.0	COMPUTER PROGRAM DEVELOPMENT AND VERIFICATION	2-1
3.0	SUMMARY AND COMPARISON OF RESULTS	3-1
4.0	CONCLUSIONS AND RECOMMENDATIONS	4-1
5.0	REFERENCES	5-1
	APPENDIX A - ENGINEERING DESCRIPTION AND USERS GUIDE FOR THE CRYOGEN TRANSFER PROGRAMS	A-1
	APPENDIX B - TRANSIENT CRYOGEN TRANSFER PROGRAM VERIFICATION PRESENTATION	B-1

D180-19190-1

ACKNOWLEDGEMENTS

Contributions to the LOX loading facility and Space Shuttle system configuration and operational input data for the Shuttle LOX Loading Transient Study were made by:

Dwight Garrison (Global Associates)
Boyce Mix (NASA, NSTL)
Tom Winstead (NASA, MSFC)
Sterling Walker (NASA, KSC)
Roy Johanson (NASA, KSC)

Contributions to modifications of the Transient Cryogen Transfer Program (TCTP) and documentation of the study results were made by the following Boeing personnel:

John R. Colson
James S. Richards
Ray Torstenson
Charlotte Wiser

Any questions concerning this document should be directed to the responsible Project Supervisor.

Charles R. Carter
JD-13
(205) 837-3748

1.0 INTRODUCTION

The purpose of the Shuttle LOX Loading Transient Study is to provide a technical basis for configuration and operation of the LOX loading facilities to be used for the Space Shuttle Main Propulsion Test Article (MPTA) at the National Space and Technology Laboratories (NSTL), and for the Space Shuttle launch facilities at the John F. Kennedy Space Center (KSC). The principal objectives of this study are to determine the acceptability of these LOX loading facilities for each proposed application and to determine the degree of similarity between the systems with respect to the applicability of data developed during operations at NSTL to the launch site operations at KSC. Further objectives are to determine facility modifications which would improve the similarity.

This study was divided into three major tasks:

- (1) Cryogen Transfer Computer Program Development and Verification, Reference 1.
- (2) National Space and Technology Laboratories (NSTL) LOX Loading Facility Analyses, Reference 2.
- (3) Kennedy Space Center (KSC) LOX Loading Facility Analyses, Reference 3.

During the course of the NSTL and KSC facility analyses, alternate facility configurations and operations were considered and evaluated. This report presents a summary of the overall Shuttle LOX Loading Transient Study results, final data comparisons, conclusions, and recommendations.

Contract NAS8-30745 was modified for an additional major task to investigate the feasibility of Transient Cryogen Transfer Program" (TCTP) application to the Space Shuttle Main Engine (SSME) hydrogen system analysis. The results and conclusions from this task are being published in a separate report.

2.0 COMPUTER PROGRAM DEVELOPMENT AND VERIFICATION

The Shuttle LOX Loading Transient Study was based upon further development and verification of the "Transient Cryogen Transfer Program" (TCTP) and "Steady State Cryogen Transfer Program" (SSCTP) as documented in Reference 1. During the NSTL and KSC facility analyses, extensive TCTP modification and development was required to simulate the proposed system configurations and operations. These modifications were incorporated into the up-dated program user's manual presented in Appendix A. The TCTP modifications provide a more generalized capability to perform transient analyses of various cryogen transfer system configurations and operations with various known boundary conditions.

During the NSTL facility analyses, the TCTP was improved to include the following capabilities:

- (1) Throttlable flow control valves.
- (2) Storage tank bottom pressure as a function of storage tank ullage pressure, liquid level, and suction line flow rate.
- (3) Pump inlet pressure and NPSH as a function of storage tank bottom pressure and suction line flowrate.
- (4) Pump by-pass flow as a function of pump discharge and storage tank pressures.
- (5) Tank head flow simulation starting from zero flow rate into hot (ambient temperature) lines.

These TCTP improvements are discussed in Reference 2. The tank head flow capability was verified by analyzing the Skylab S-IB Stage LOX loading system initial tank head flow chill-down and comparing analytical results to available measured data. A comparison of analytical and existing measured data is shown in the Appendix B presentation. Considering the accuracy that the available strip chart data can be read (± 2 psi and ± 1.5 LB/SEC) and the spread

2.0 (Continued)

between the two redundant pump discharge flow rate transducers (33G01 and 33G08) the analytical results agree well with measured data. This analysis also revealed that transient quality and flow rate gradients exist in the system at the end of the tank head flow portion of line chill-down just prior to the initial 1,000 GPM pump RPM ramp. Using the transient flow rate, quality, pressure, and temperature gradients at the end of tank head flow as input, the pump flow portion of the system chill-down was reanalyzed. Results of this additional program verification are shown in Appendix B. The resulting transient flow rate and pressure gradients were approximately the same as those reported in Reference 1. The analytical time at which the vapor volume fraction goes to zero at the LOX mast measurement location is 212 seconds from the initial RPM ramp, while the measured data indicates that the transition to liquid flow occurs at approximately 203 to 224 seconds, as reported in Reference 1.

During the KSC facility analyses, Reference 3, additional improvements were made to the TCTP to include the following capabilities:

- (1) Throttlable branch flow to the supply tank reservoir (KSC LOX by-pass).
- (2) Check valve downstream of pump chill-down drain line.
- (3) Improved system bleed flow simulation to compute bleed flow rate as a function of system node pressure and density and bleed system exit pressure.
- (4) Option to compute required pump speed as a function of input system entrance flow rate and computed pump discharge pressure instead of system entrance flow rate as a function of input pump speed and computed pump discharge pressure.

3.0 SUMMARY AND COMPARISON OF RESULTS

The suggested tank head flow facility chill-down period is 4 minutes for the NSTL facility, Reference 2, and 10 minutes for the KSC facility, Reference 3. The chill-down times are expected to be different for the two facilities due to differences in system configurations, system operations, heat loads, and supply tank conditions. However, the transient conditions in the Orbiter and 17 inch ET fill duct are very similar over the facility chill-down period. From Reference 2, Figure 2-3, and Reference 3, Figure 3-2, the Orbiter (ORB)/Ground Service Equipment (GSE) interface flow rates are between 2 and 4 LB_M/SEC over most of the chill-down period at both facilities. At the end of the tank head flow chill-down period, the ORB/GSE flow rates are 3.6 and 2.9 LB_M/SEC for the NSTL and KSC facilities. During this period the maximum, or peak, gas flow rate to the ET is 3.0 and 8.5 LB_M/SEC at NSTL and KSC respectively. Comparison of Reference 2, Figure 2-4 and Reference 3, Figure 3-3 shows that the percent vapor by mass (quality) decreases slightly more at NSTL than at KSC during the facility chill-down. At the end of this period the NSTL ORB/GSE quality is 0.14 and the KSC ORB/GSE quality is 0.26. From Reference 2, Figures 2-5 and 2-6, and Reference 3, Figures 3-4 and 3-5, the ORB/GSE interface and vehicle fluid and duct wall temperatures are essentially the same for both facilities at the end of tank head flow chill-down.

Reference 2, Figure 2-9, shows that the NSTL facility is filled with liquid with 100 percent liquid flow at the ORB/GSE interface at 1.9 minutes after the pump flow slow fill initiation and the 17 inch duct is filled to the upper aluminum/stainless steel joint at 16.5 minutes after slow fill initiation. Reference 3, Figures 4-4 and 4-11, show that the KSC facility is filled with liquid at 2.8 minutes after slow fill initiation and the 17 inch duct is filled to the upper aluminum/stainless steel joint after a total of 24.7 minutes of slow fill time. The longer required fill time for the KSC facility is due to the higher overall heat load for the facility. Alternate

3.0 (Continued)

KSC Orbiter chill down and vehicle slow fill analyses with various flow rates showed that the required fill times may be changed significantly with different controlled flow rates. At the end of the slow fill periods evaluated, Reference 2, Figures 2-10 through 2-12, and Reference 3, Figures 4-12 through 4-14 show that the ORB/GSE interface and vehicle pressures, fluid temperatures, and duct wall temperatures are all very similar.

Results of these analyses show that the facility and Orbiter chill-down and slow fill can be accomplished within the target time of 43 minutes at both facilities provided that the SSME engine chill-down can be accomplished simultaneously with the Orbiter chill-down and vehicle slow fill, and no engine chill hold time is required at KSC.

4.0 CONCLUSIONS AND RECOMMENDATIONS

The results of the NSTL and KSC facility analyses, References 2 and 3, lead to the following major conclusions:

- (1) Shuttle vehicle interface conditions at both facilities will be approximately the same after the tank head flow facility chill-down period.
- (2) Similar vehicle interface conditions can be maintained at both facilities during and after the pump flow slow fill initiation with flow control valve or pump RPM adjustments at either facility.
- (3) The facility/vehicle chill-down and slow fill to the ET (tank bottom) can be accomplished within the target time of 43 minutes at both facilities.
- (4) Desired flow control or operational procedure adjustments and accurate system performance predictions for KSC launch operations can be derived from NSTL test results coupled with further TCTP analyses.

Results of the NSTL facility analyses, Reference 2, indicate that a sudden increase in flow control valve upstream and pump discharge pressures will occur when 100 percent liquid flow reaches the flow control valve (LCV-114). At this time, the flow downstream of LCV-114 will be choked. This sudden increase in pressures and choked flow condition could be avoided by one or more of the following changes to the planned system configuration or operation:

- (1) Increase the barge tank ullage pressure, system flowrate, and tank head flow period to achieve 100 percent liquid at LCV-114 prior to pump start.
- (2) Increase the replenish pump RPM slowly with LCV-114 held open until 100 percent liquid reaches the valve at a low flowrate.

4.0 (Continued)

- (3) Use a larger flow control valve and downstream line size.

Results of both facility analyses indicate that after the 17 inch Shuttle ET fill duct is filled with liquid to the aluminum/stainless steel joint (10 feet below the ET) steady state conditions will be approached with the liquid mass flow rate approaching the total mass flow rate (low quality) at the ET entrance. However, the 2-phase fluid will be approximately 60 percent vapor by volume at the ET entrance. If it is desired to guarantee 100 percent liquid flow at the ET entrance at the end of the system chill-down and slow fill, one or more of the following changes should be considered for the planned system configuration or operation:

- (1) Decrease the system inlet or vehicle interface LOX temperature.
- (2) Decrease the external heat load (improve the system insulation).
- (3) Increase the system flow rate during the 17 inch duct fill.
- (4) Maintain a higher ullage pressure (approximately 19.5 PSIA) in the ET to increase the tank bottom pressure above saturation pressure.

D180-19190-1

5.0 REFERENCES

1. Boeing Letter Report 5-9030-HT-158, "Cryogen Transfer Computer Program Development and Verification," dated September 3, 1974.
2. Boeing Letter Report 2-1056-HT-082, "National Space and Technology Laboratories (NSTL) LOX Loading Facility Analyses," dated May 8, 1975.
3. Boeing Letter Report 2-1056-HT-164, "Kennedy Space Center (KSC) LOX Loading Facility Analyses," dated December 1, 1975.

D180-19190-1

APPENDIX A

ENGINEERING DESCRIPTION AND USERS GUIDE
FOR THE CRYOGEN TRANSFER PROGRAMS

This Appendix presents an up-date to Boeing Letter Report 5-9030-HT-158, "Cryogen Transfer Computer Program Development and Verification", Appendix B, dated September 3, 1974. Contents of this Appendix represent the latest Cryogen Transfer Program theory and input data format for both the TCTP and SSCTP.

TRANSIENT CRYOGEN TRANSFER SYSTEM ANALYSIS

1.0 CONTROLLING EQUATIONS

1.1 MASS

From Reference 1, the equation of continuity for one-dimensional transient flow is,

$$\frac{\partial}{\partial t} M = \dot{M}_{IN} - \dot{M}_{OUT}$$

or in finite difference notation for constant flow rates over Δt ,

$$\frac{M_{NF} - M_{NI}}{\Delta t} = (\dot{M}_{N-1} - \dot{M}_N) \quad (1)$$

where at any instant the mass contained within the control volume or line node is,

$$M_N = \rho_N V_N = \rho_N A_N \ell_N \quad (2)$$

and the flow rate leaving a node during a time step is,

$$\dot{M}_N = \rho'_N V_N A_N \quad (3)$$

where ρ'_N is the effective average density over the time step, and for the finite difference integration, assumed to equal the final value for the time step.

$$\rho'_N = \rho_{FN} \quad (4)$$

1.2 ENERGY

The thermodynamic system boundary prior to a time step, dt , is considered to include the fluid within the control volume, or line node, plus the increment of fluid which will enter the node during the time step. The same system at the end of the time step includes the fluid within the line node plus the increment of fluid which left the node during the time step. In the limit as dt approaches zero, the system boundary coincides with the control volume, or line node.

The energy added to the system during the process is,

$$(\dot{M}_{N-1} dt) \left(\frac{P_{N-1}}{\rho_{N-1} J} \right) + q_N dt$$

where $(P_{N-1}/\rho_{N-1} J)$ is the flow work done on the fluid within the node per pound of fluid forced past the entrance, and q_N is the rate of heat transfer from the wall to the fluid.

1.2 (Continued)

The energy removed from the system during the process is the flow work done by the fluid within the node to force $\dot{M}_N dt$ pounds of fluid past the node exit,

$$(\dot{M}_N dt) \left(\frac{P_N}{\rho_N J} \right)$$

The energy possessed by the system in its initial state is,

$$M_I U_I + (\dot{M}_{N-1} dt) \left(U + \frac{gZ}{g_C J} + \frac{v^2}{2g_C J} \right)_{N-1}$$

and in its final state,

$$M_F U_F + (\dot{M}_N dt) \left(U + \frac{gZ}{g_C J} + \frac{v^2}{2g_C J} \right)_N$$

Equating the difference between the energy added and removed to the change in energy possessed by the system gives,

$$\begin{aligned} & (\dot{M}_{N-1} dt) \left(\frac{P_{N-1}}{\rho_{N-1} J} \right) + q_N dt - (\dot{M}_N dt) \left(\frac{P_N}{\rho_N J} \right) \\ & = M_F U_F - M_I U_I + (\dot{M}_N dt) \left(U + \frac{gZ}{g_C J} + \frac{v^2}{2g_C J} \right)_N - (\dot{M}_{N-1} dt) \left(U + \frac{gZ}{g_C J} + \frac{v^2}{2g_C J} \right)_{N-1} \end{aligned}$$

By definition the enthalpy is,

$$h \equiv \left(U + \frac{P}{\rho J} \right)$$

and the final mass from equation (1) is:

$$M_F = (\dot{M}_{N-1} - \dot{M}_N) \Delta t + M_I$$

By combining terms and substituting the above expressions for enthalpy and final mass, the energy equation may be solved in finite difference form for the final internal energy,

$$\begin{aligned} U_{NF} = & \frac{[\dot{M}_{N-1} (h' + \frac{gZ}{g_C J} + \frac{v^2}{2g_C J})_{N-1} - \dot{M}_N (h' + \frac{gZ}{g_C J} + \frac{v^2}{2g_C J})_N] \Delta t}{[\dot{M}_I + (\dot{M}_{N-1} - \dot{M}_N) \Delta t]} \\ & + \frac{(h_{CN} A_{NW} (T_W - T)_N \Delta t / 3600) + (MU)_{NI}}{[\dot{M}_I + (\dot{M}_{N-1} - \dot{M}_N) \Delta t]} \end{aligned} \quad (5)$$

1.2 (Continued)

where

$$q_N = \frac{h_{CN} A_{NW} (T_W - T)_N}{3600}$$

1.3 MOMENTUM

1.3.1 Constant Area

For a constant area control volume or line segment and one-dimensional transient flow, the momentum theorem, Reference 1, becomes

$$\Sigma F_N = \frac{1}{g_C} \left[\frac{\partial}{\partial t} (\rho v)_{N-1} dV_N + (\rho_N v_N^2 A_N) - (\rho_{N-1} v_{N-1}^2 A_N) \right]$$

where the time rate of change in momentum for node, n, is evaluated at the node entrance conditions. The partial derivative of (ρv) with respect to time is,

$$\frac{\partial}{\partial t} (\rho v) = \rho \frac{\partial v}{\partial t} + v \frac{\partial \rho}{\partial t}$$

where ρ and v are instantaneous local values. For finite time steps, the partial derivative of ρv with respect to time becomes,

$$\begin{aligned} & \left[\frac{\rho_F + \rho_I}{2} (v_F - v_I) + \frac{v_F + v_I}{2} (\rho_F - \rho_I) \right] \frac{1}{\Delta t} \\ & = (\rho_F v_F - \rho_I v_I) \frac{1}{\Delta t} \end{aligned}$$

The line element or node volume is defined as,

$$V_N = A_N \ell_N$$

The momentum theorem may then be written in finite difference form as,

$$\begin{aligned} \Sigma F_N &= \frac{1}{g_C \Delta t} \left[(\rho_{(N-1)F} v_{(N-1)F} - \rho_{(N-1)I} v_{(N-1)I}) A_N \ell_N \right. \\ & \left. + (\rho_N v_N^2) A_N \Delta t - (\rho_{N-1} v_{N-1}^2) A_N \Delta t \right] \end{aligned}$$

The summation of forces in the direction of flow on a constant area line increment is,

$$\begin{aligned} \Sigma F_N &= (p_{N-1} A_N)_F - \left[(p_{N-1} A_N + \frac{\partial p A}{\partial x} dx)_F + \tau \pi D_N d\ell_N \right. \\ & \left. + (\rho_{NF} \frac{g}{g_C}) A_N dZ \right] \end{aligned}$$

1.3.1 (Continued)

For a finite line node length, the shear force ($\tau \pi D_N \Delta \ell_N$) is balanced by the pressure drop due to friction along the constant area pipe wall, i.e.,

$$(\tau \pi D_N \Delta \ell_N) - (P'_{N-1} - P_N) F A_N = 0$$

$$\text{or } \Delta P_{FN} = (P'_{N-1} - P_N) F = \frac{\tau \pi D_N \Delta \ell_N}{A_N}$$

where the subscript, F, denotes frictional pressure drop.

The summation of forces over a finite line length may now be written,

$$\Sigma F_N = -A_N [(P_N - P'_{N-1}) + \Delta P_{FN} + \rho \left(\frac{g}{g_C}\right) (Z_N - Z_{N-1})]$$

By combining terms and rearranging, the momentum of equation may now be solved for the change in pressure across a constant area line length,

$$(P_N - P'_{N-1}) = \frac{\rho \Delta \ell_N}{g_C} (\rho (N-1) I V'_{(N-1)I} - \rho (N-1) F V'_{(N-1)F})$$

$$+ (\rho_{N-1} v_{N-1}^2 / g_C) - (\rho_{NI} v_{NI}^2 / g_C)$$

$$- \Delta P_{FN} - \rho \left(\frac{g}{g_C}\right) (Z_N - Z_{N-1}) \quad (6)$$

1.3.2 Area Change

If a constant area node is preceded by an area change, the velocity and pressure entering the node must be corrected. It is assumed that the mass flow rate entering the area change interface is equal to the mass flow leaving, and that negligible change in density occurs across the thin interface. The flow conditions across an area change may be approximated by the Bernoulli equation modified to account for frictional pressure drop due to abrupt area changes,

$$(P_{N-1} - P'_{N-1}) + \frac{\rho_{N-1} (v_{N-1}^2 - v_{N-1}'^2)}{2g_C} = \Delta P'_{FN}$$

144

$$\text{and } v_{N-1} A_{N-1} = v_{N-1}' A_N$$

The velocity entering node, n, is then

$$v_{N-1}' = v_{N-1} (A_{N-1} / A_N) \quad (7)$$

D180-19190-1

1.3.2 (Continued)

and by substitution into the modified Bernouli equation, the change in pressure across an area change just upstream of node, n, is

$$(P_{N-1}' - P_{N-1}) = \frac{[1 - (A_{N-1}/A_N)^2] \left(\frac{\rho}{2} \frac{V^2}{C^2}\right)}{144} - \Delta P_{FN} \quad (8)$$

TRANSIENT CRYOGEN TRANSFER SYSTEM ANALYSIS

2.0 SUBSIDIARY EQUATIONS

2.1 HEAT TRANSFER

2.1.1 Heat Balance

The heat transfer rate from the external environment to the wall minus the heat transfer rate from the wall to the fluid is equal to the rate heat is stored by the wall:

$$q_{EXT} - q = \frac{M_W C_W (T_{WF} - T_{WI})}{\Delta t}$$

Solving for the final node wall temperature,

$$T_{WNF} = T_{WNI} + \left(\frac{q_{EXT} \Delta t}{M_W C_W} \right)_N - \frac{h_{CN} A_{NW} (T_{WNI} - T_{NI}) \Delta t}{3600 M_W C_W} \quad (9)$$

The transient heat transfer rate q_{EXT} is determined as a function of the initial wall temperature for q_{EXT} the time step by the following equation:

$$q_{EXT_N} = q_{EXT(MAX)_N} (520 - T_{WNI}) / (520 - T_{1F}) \quad (9a)$$

where $q_{EXT(MAX)}$ is the maximum steady state external heat transfer rate with cold liquid in the line and with the wall temperature, T_W , approximately equal to the pump discharge temperature, T_{1F} . $q_{EXT(MAX)}$ is input to the computer program.

2.1.2 Two Phase Flow Heat Transfer Coefficient

For this problem, heat transfer from the wall may take place to a single phase (liquid or gas) or a two phase fluid. Also, the quality of the fluid in a line mode may vary with time. Since the available two phase correlations do not reduce to the single phase liquid correlation as the quality approaches zero, a linearization between the two correlations will be used. The selected two phase correlation does, however, roughly approximate the single phase correlation at high quality.

The two phase heat transfer correlation from Reference 2 was selected as the correlation most applicable to the cryogen transfer system with initial chill-down and significant variations in hydrostatic head which cause liquid vaporization. Although the system being analyzed will have relatively low wall to fluid temperature differences, it is reasoned that the two phase flow model will be similar to that envisioned by the authors of Reference 2 due to the relatively high liquid velocity at significant vapor volume fractions. The flow model is assumed to have

2.1.2 (Continued)

a vapor film at the wall with liquid droplet impingement on the wall at higher values of vapor volume fraction. The following Nusselt number correction factor for two-phase flow at qualities between 0.010 and 1.0 was obtained from Reference 2 and a telephone conversation with Mr. R. C. Hendricks correcting a printing error in Reference 2:

$$\left(\frac{NU_E}{NU_C}\right)_N = \frac{1}{0.611 + 1.93\psi_{TT}} + 0.15^* \quad (10)$$

where ψ_{TT} is the Martinelli two-phase flow parameter,

$$\psi_{TT} = \left(\frac{1-X}{X}\right)_N^{0.9} \left(\frac{\mu_V}{\rho_L}\right)_N^{0.5} \left(\frac{\mu_L}{\mu_V}\right)_N^{0.1} \quad (11)$$

*The above constant (0.15) was changed to 0.221 to improve correlation with S-IB Stage LOX loading system two-phase heat transfer.

The reference or calculated Nusselt number used in the Reference 2 correlation is evaluated with a Dittus-Boelter equation using the two phase bulk density and the vapor film viscosity, specific heat, and conductivity. For qualities between 0.010 and 1.0, the two-phase flow film coefficient is then given by:

$$h_{CN} = h_{CLVN} = 0.021 \frac{K_V}{D_N} \left[\frac{(\rho VD)_N}{\mu_V}\right]^{0.8} (P_{RV})^{0.4} \left(\frac{NU_E}{NU_C}\right)_N \quad (12)$$

using average vapor film properties over the expected temperature range. Additional discussions of this two-phase flow heat transfer correlation are given in References 3 and 4.

For $X_N = 0$, the single phase liquid film coefficient is given by:

$$h_{CN} = h_{CLN} = 0.021 \frac{K_L}{D_N} \left(\frac{\rho_L V_N D_N}{\mu_L}\right)^{0.8} (P_{RL})^{0.4} \quad (13)$$

using the average liquid properties over the expected temperature range.

For X_N between 0 and 0.010, a straight line interpolation between the single phase liquid film coefficient and the 2-phase value is assumed to be approximately correct.

2.2 FRICTIONAL PRESSURE DROP

2.2.1 Two-Phase Flow Line Losses

The selected two-phase flow line frictional pressure drop correlation was taken from Reference 5 which uses a two-phase flow friction factor correlation from Reference 6. No-slip homogeneous bubble or froth flow is assumed due to the relatively high anticipated liquid velocities. For no-slip flow, the vapor volume fraction is:

$$\alpha_N = \frac{1}{1 + \frac{\rho_V}{\rho_L} \left(\frac{1 - X_N}{X_N} \right)} \quad (14)$$

The two-phase fluid viscosity is:

$$\mu_N = \mu_V \alpha_N + \mu_L (1 - \alpha_N)$$

where average values of liquid and vapor viscosities may be used over the expected temperature range. As suggested by Reference 5, a single phase friction factor is determined from an existing single phase correlation as a function of the two-phase Reynolds number:

$$f_{ON} = 0.0014 + \frac{0.125}{\left(\frac{\rho_V D}{\mu} \right)_N^{0.32}} \quad (15)$$

This single phase correlation is for smooth pipes. Other existing correlations may be substituted for other than smooth pipes. The two-phase flow friction factor correction from Reference 6 is:

$$\left(\frac{f_{TP}}{f_0} \right)_N = \left(\frac{1/2 Eu_{TP}}{f_0} \right) = \left[1 - \frac{\ln(1-\alpha)}{1.281 + .478 \ln(1-\alpha) + .444 \ln^2(1-\alpha) + .094 \ln^3(1-\alpha) + .00843 \ln^4(1-\alpha)} \right]_N^* \quad (16)$$

The friction pressure loss in each constant area node is:

$$\Delta P_{FN} = \left(\frac{f_{TP}}{f_0} \right)_N \left[K_E + \frac{4 f_0 l}{D} \right]_N \left(\frac{\rho_N - 1 V_N^2}{288 g_C} \right)_N \quad (17)$$

where K_E is the loss coefficients for hardware elements in each node.

*Multiplying $(f_{TP}/f_0) - 1$ by a factor of 3.25 resulted in a slight improvement of analytical correlation with measured S-IB Stage LOX loading system two-phase flow pressures.

2.2.2 Line Area Change Losses

Reference 7 suggests that for homogeneous two-phase flow, head losses across abrupt expansions and contractions can be predicted using coefficients for single phase flow. For contractions:

$$\Delta P'_{FN} = \frac{K_{AN}}{144} \left(\frac{\rho_{N-1} v_{N-1}^2}{2g_C} \right) \quad (18)$$

From Reference 8, the contraction loss coefficient as a function of diameter ratio is:

TABLE 2-1

$\frac{D_N}{D_{N-1}}$	0.1	0.2	0.3	0.4	0.5	0.6	0.7	0.8	0.9
K_{AN}	0.45	0.42	0.39	0.36	0.33	0.28	0.22	0.15	0.06

For Expansions:

$$\Delta P'_{FN} = \frac{K_{AN}}{144} \left(\frac{\rho_{N-1} v_{N-1}^2}{2g_C} \right) \quad (19)$$

where the expansion loss coefficient from Reference 8 is:

$$K_{AN} = \left(1 - \frac{A_{N-1}}{A_N} \right) \quad (20)$$

2.3 SYSTEM PRESSURES

The total change in pressure across each node and an area change just upstream may be determined by adding equations (5) and (7):

$$\Delta P_N \equiv (P_N - P_{N-1}) = (P_N - P'_{N-1}) + (P'_{N-1} - P_{N-1}) \quad (24)$$

The pressure leaving each node, n, is then

$$P_N = P_K + \sum_{N+1}^K (-\Delta P)_N \quad (25)$$

where P_K is the known final node discharge pressure.

2.4 SYSTEM FLOW RATES

2.4.1 System Entrance Flow Rates

In addition to the above flow controlling equations, a relationship for flow rate entering the system is required to complete the solution for system flow rates. This analysis considers the incoming flow to be controlled by the flow rate characteristics for a given pump as a function of outlet pressure and RPM. For a pressure transfer system, a suitable flow rate equation for a known flow controlling valve, orifice, or system entrance loss may be substituted. The pump performance characteristics may be normalized to give:

$$\left(\frac{\dot{M}_1}{N}\right) = f\left(\frac{P_1 - P_{IN}}{N^2}\right) \quad (26)$$

The pump flow rate is then:

$$\dot{M}_1 = N (\dot{M}_1/N) \quad (27)$$

where N is the known pump RPM as a function of time. The flow rate leaving each node is determined by a simultaneous solution of the energy, mass and fluid property equations.

2.4.2 System Branch or Bleed Exit Flow Rate

For special problems where branches or bleed flow leaves a given system node as a known function of the system node exit pressure, the bleed flow rate may be subtracted from the system node exit flow rate. The bleed flow rate may be calculated by the following equation:

$$\dot{m} = \sqrt{(288g_c) \rho_N A_{BL}^2 [P_N - P_{EX} - \rho_N (Z_{EX} - Z_N)/144] / K_E}$$

where A_{BL} is the branch or bleed equivalent flow area, P_{EX} is the branch line or bleed system exit pressure, Z_{EX} is the branch line or bleed system exit elevation, and K_E is the equivalent friction loss coefficient.

Combining constants, this equation becomes,

$$\dot{m} = \sqrt{C_{BP1} \rho_N [P_N - P_{EX} - C_{BP2} \rho_N]}$$

$$\text{where } C_{BP1} = (288g_c A_{BL}^2 / K_E)$$

$$\text{and } C_{BP2} = (Z_{EX} - Z_{IN}) / 144$$

2.4.3 Two-Phase Choked Flow

Relations were derived to check for two-phase choked flow and to adjust the flow rates if necessary. However, due to the many other numerical sensitivity problems encountered during program development insufficient time was available to develop an operational program routine to automatically adjust system flow rates to prevent exceeding choked flow at any node. The current program does limit node entrance and exit velocities to computed choked flow values for the purpose of calculating node pressure drops. If choked flow is exceeded at a system node exit, choked flow conditions can be simulated by controlling the flow with a flow control valve input as discussed in Reference 10.

For a unit volume, the compressibility is by definition:

$$K = \frac{1}{V} \frac{dV}{dP}$$

The mixture volume is,

$$V_M = V_L + V_V$$

Therefore, for the mixture, the compressibility is:

$$K_M = -\frac{1}{V_M} \left(\frac{dV_L + dV_V}{dP} \right) = -\frac{1}{V_M} (V_L K_L + V_V K_V)$$

The vapor volume fraction is by definition

$$\alpha = \frac{V_V}{V_M} \quad \text{and} \quad \frac{V_L}{V_M} = (1 - \alpha)$$

Substituting into the above expression for compressibility yields:

$$K_M = K_L (1 - \alpha) + K_V \alpha$$

The bulk modulus is defined as the reciprocal of compressibility. Therefore,

$$K = \frac{1}{\beta}$$

and,

$$\frac{1}{\beta_M} = \frac{(1 - \alpha)}{\beta_L} + \frac{\alpha}{\beta_V}$$

2.4.3 (Continued)

From the above definitions of compressibility, and bulk modulus it may be shown that

$$c = \sqrt{\frac{dP}{d\rho}}$$

and from Reference 1, the speed of sound is,

$$c = \sqrt{\frac{dP}{d\rho} gc(144)} = \sqrt{\frac{\beta_M}{\rho_M} gc(144)}$$

The choked flow rate per unit area at Mach No. equals 1 is then,

$$\frac{\dot{M}^*}{A} = \rho_M c = \sqrt{\rho_M \beta_M gc(144)}$$

and substituting the above expression for the mixture bulk modulus gives the two-phase choked flow rate as a function of the vapor bulk modulus or pressure,

$$\dot{M}_N^* = A_N \sqrt{\frac{\rho_{MN} gc(144)}{\frac{1-\alpha_N}{\beta_L} + \frac{\alpha_N}{\beta_{VN}}}}$$

where the node vapor isentropic bulk modulus is,

$$\beta_{VN} = \rho_{VN} \gamma_V (RT_N)/144 = \gamma_V P_N$$

The results of the above equations are shown in Figures 1 - 4.

2.5 FLUID PROPERTY RELATIONS

In order to complete the solution of the above equations, several additional state point property relationships or thermodynamic tables are required.

For the simultaneous energy and mass balance, the vapor density and the saturated liquid and vapor internal energy are determined from thermodynamic tables at the current assumed node pressure ($P_{FN} = P_{AN}$).

The node quality at the beginning or end of a time step is determined from the internal energy at the current pressure,

$$X_N = \frac{U_N - U_{LSN}}{U_{VSN} - U_{LSN}} \quad (28)$$

2.5 (Continued)

For the finite difference integration, the effective average quality for the time step is assumed equal to the final value for the time step,

$$\bar{X}_N = X_N \quad (29)$$

The density at the beginning or end of a time step is determined from the quality at the current pressure,

$$\rho_N = \frac{1}{\frac{1 - X_N}{\rho_{LN}} + \frac{X_N}{\rho_{VSN}}} \quad (30)$$

If the final quality is between 0 and 1, the final temperature is the saturated temperature, T_{SN} , at the assumed final pressure. If the final state is subcooled ($X_{NF} = 0$) or superheated, ($X_F = 1$) the final temperature is determined from

$$T_N = T_{SN} - \frac{U_S - U_N}{C} \quad (31)$$

where $U_S = U_{VS}$ and $C = C_{VV}$ for $X_N = 1$

and $U_S = U_{LS}$ and $C = C_{PL}$ for $X_N = 0$

Also, the enthalpy leaving the node during the time step is determined from

$$h'_N = U_{FN} + \frac{\dot{F}_{FN}}{\rho'_N J} \quad (32)$$

TRANSIENT CRYOGEN TRANSFER SYSTEM ANALYSIS

3.0 SYSTEM ANALYSIS

3.1 FIRST TIME STEP INITIAL VALUES

3.1.1 Initial Node Properties

The initial node pressures, temperatures, and qualities must be input to the program. Originally, the node bulk average quality, X_N , and the local quality leaving the node, X'_N , were input to the program. The current program requires only the initial node exit quality input, and the node bulk and exit qualities are considered to be equal. In the current program solution flow, the effective average quality over a time step is designated by X^*_N and is equal to X_N at initial conditions. If the node quality is between 0 and 1, the temperature may be input as zero and the program will determine the saturated node temperature from a table as a function of the input pressure. The initial temperature entering the first line node, T_{1I} , is the known pump outlet temperature.

The initial density, ρ_{NI} , is determined for each node from equation (30), where X_N is the known or assumed initial node bulk quality and the vapor density, ρ_{VSN} , is evaluated from a thermodynamic table as a function of the node initial temperature and pressure. The liquid density, ρ_{LN} , is calculated from curve fit data for the specified cryogen. The initial node internal energy U_{NI} , may be determined for each node from equation (28), where X_N is the known or assumed initial node bulk quality and U_{VSN} and U_{LSN} are the vapor and liquid internal energies of the specified cryogen evaluated from thermodynamic tables at the node saturation conditions, P_{NI} and T_{SNI} . If the node is subcooled or superheated, the initial internal energy is determined from equation (31) at the input initial temperature.

3.1.2 Initial Node Mass, Flow Rate and Velocities

With the initial node density from equation (30) and the known system geometry, the initial mass in each line node may be determined from equation (2). The initial pump flow rate is determined from the known pump performance function, equation (26) and equation (27), using the initial pump outlet pressure, P_{1I} , in PSIG and the known initial RPM.

For initial flow at steady state, the flow rate out of each node is equal to the pump flow rate,

$$\dot{M}_{NI} = \dot{M}_{1I}$$

and the initial velocity leaving each node is determined from equation (3).

If there is an area change at a node entrance, the entering initial velocity is determined from equation (7).

3.1.3 Initial External Heat Transfer

If the system is initially at a non-steady condition, the initial external heat transfer rate is calculated with equation (9a). If the system is initially at a steady state condition, e.g. zero flow, the external heat transfer is:

$$q_{EXT_N} = h_{CNI} q_{EXT(MAX)_N} (520 - T_{NI}) / [(520 - T_{1F}) h_{CNI} + q_{EXT(MAX)_N}]$$

where $q_{EXT(MAX)}$ is the maximum steady state external heat transfer program input.

3.1.4 Initial Wall Temperature

If the system is initially at a non-steady condition the initial node wall temperatures must be input to the program. The initial wall heat transfer coefficient is determined from equation (12), (13), or (14) depending on the initial quality, and at steady state the initial wall temperature is

$$T_{WNI} = T_{NI} + \frac{q_{EXT}}{h_{CNI} A_{NW}}$$

3.2 SYSTEM SOLUTION FLOW

After the first time step initial values have been determined, the procedure outlined on Figure 5 is utilized to determine the pump outlet and line node conditions for subsequent time steps.

A "DO LOOP" is used for consecutive nodes, 2 through K where K is the system exit node, to determine the initial vapor volume fraction, α_{NI} , wall film coefficient, h_{CN} , and wall temperature T_{WNI} . The initial vapor volume fraction is determined from equation (14) at the beginning of each time step as a function of final quality and vapor density from the previous time step. The wall film coefficient is assumed constant over the time step and based on initial flow conditions.

If the initial node quality is zero (single phase liquid) or less than 0.01, the heat transfer film coefficient is determined from equation (13). If the initial node quality is between 0.01 and 1.0, the heat transfer film coefficient is determined from equations (10), (11) and (12).

3.2 (Continued)

The pump RPM (or flow rate) and exit temperature, T_{FI} , are determined from input data tables as a function time. If the pump RPM is input, the pump flow rate is a function of pump outlet pressure, and the pump outlet pressure is a function of system flow rates and pressure drop, an iterative solution is required to determine the final pump pressure for each time step. For the first assumed pump pressure, the pump pressure rise divided by the RPM squared is assumed to be approximately constant from one time step to the next. Therefore, the first assumed pump pressure is:

$$P_{FA1} = (P_{I1} - P_{IN}) \left(\frac{RPM}{PPM_I} \right)^2 + P_{IN}$$

For each assumed pump pressure, the pump flow rate is determined from an input data table, equation (26) and equation (27). The pump outlet velocity is then determined from equation (3).

For each pump flow rate, the quality and flow rate out of each consecutive node is a function of the current node pressure, and the node pressure is a function of the system pressure drop at the current flow conditions. Therefore, for each assumed pump flow condition, an iterative solution is required for the system pressure distribution. For the first assumed node pressures, P_{AN} , each node pressure is assumed to be the last assumed value for the previous time step.

A "DO LOOP" is used for consecutive nodes from the pump to the system exit to determine the energy and mass balance for each consecutive node. Therefore, when entering the "DO LOOP" for a given node, the flow conditions and enthalpy leaving the upstream node are known. If the flow area changes at the node entrance, the velocity entering the node is determined from equation (7). The current vapor volume fraction for the upstream node is determined from equation (14) as a function of the current quality and vapor density where the vapor density is determined from a thermodynamic table as a function of pressure and temperature. The node friction pressure drop is then determined from the equations given in paragraph 2.2.1 as a function of entering flow conditions. If the flow area changes at the node entrance, the entrance pressure loss is determined from equation (18) or (19) and equation (8).

For the energy and mass balance, the final state is first assumed to be two-phase (X_{FN} between 0 and 1) at the current assumed node pressure. The fluid temperature is equal to saturation temperature and the wall temperature is determined from equation (9). Equations (1), (3), (28), (30), (5), (32), and (2) are then solved simultaneously in terms of the final mass. This equation is a cubic polynomial. The first real, positive root is selected for the final mass, and if no real, positive root exists, a real, negative root is selected. After the final mass has been determined, the final internal energy, and quality are deter-

3.2 (Continued)

mined from equations (2), (30), and (28). If the final quality from the two-phase solution is less than 0, it is set equal to 0, and if the final quality is greater than 1, it is set equal to 1. The final density is then determined from equation (30).

If the final quality from the two-phase solution is 0 or 1, the above solution for final mass and internal energy is invalid. If the final quality is 0, the final one-phase density is the liquid density, or if the final quality is 1, the final one-phase density is the vapor density. The final vapor density is approximated here from the vapor density table as a function of the current assumed pressure and initial temperature. The one-phase final mass is then determined from equation (2).

After the final density has been determined for either the two-phase or one-phase case, the effective average values of density, node exit flow rate, exit velocity, and quality are determined from equations (4), (1), (3), and (29) respectively.

For the one-phase case ($X_{FN} = 0$ or 1) the final internal energy, effective average enthalpy, final temperature, and final wall temperature are determined from a simultaneous solution of equations (5), (32), (31) and (8).

For both the 2-phase and the 1-phase solutions the effective average enthalpy is determined from equation (32).

After the energy and mass balance has been completed for all the system nodes at the assumed current pressures, the current system pressure distribution is determined from equations (5), (24) and (25). Each calculated node pressure is compared to the assumed value, and if necessary, a new system pressure profile is assumed. The energy and mass balance is repeated at the new assumed pressures until the resulting calculated pressures approach the assumed values.

After the line node pressure iteration is complete, the calculated pump back pressure is compared to the assumed value. If necessary, a new pump exit pressure is assumed and the above system energy and mass balance and system pressure iteration is repeated at the new pump flow rate. After the calculated pump pressure converges with the assumed values, the calculations for the time step are concluded.

3.3 ALTERNATE BRANCH FLOW

The program has a provision to switch branches of flow to the system exit at any prescribed time, e.g. close the vent line and open the receiver tank fill line.

FIGURE 1
SATURATED LOX/GOX MIXTURE
DENSITY VS VAPOR VOLUME FRACTION

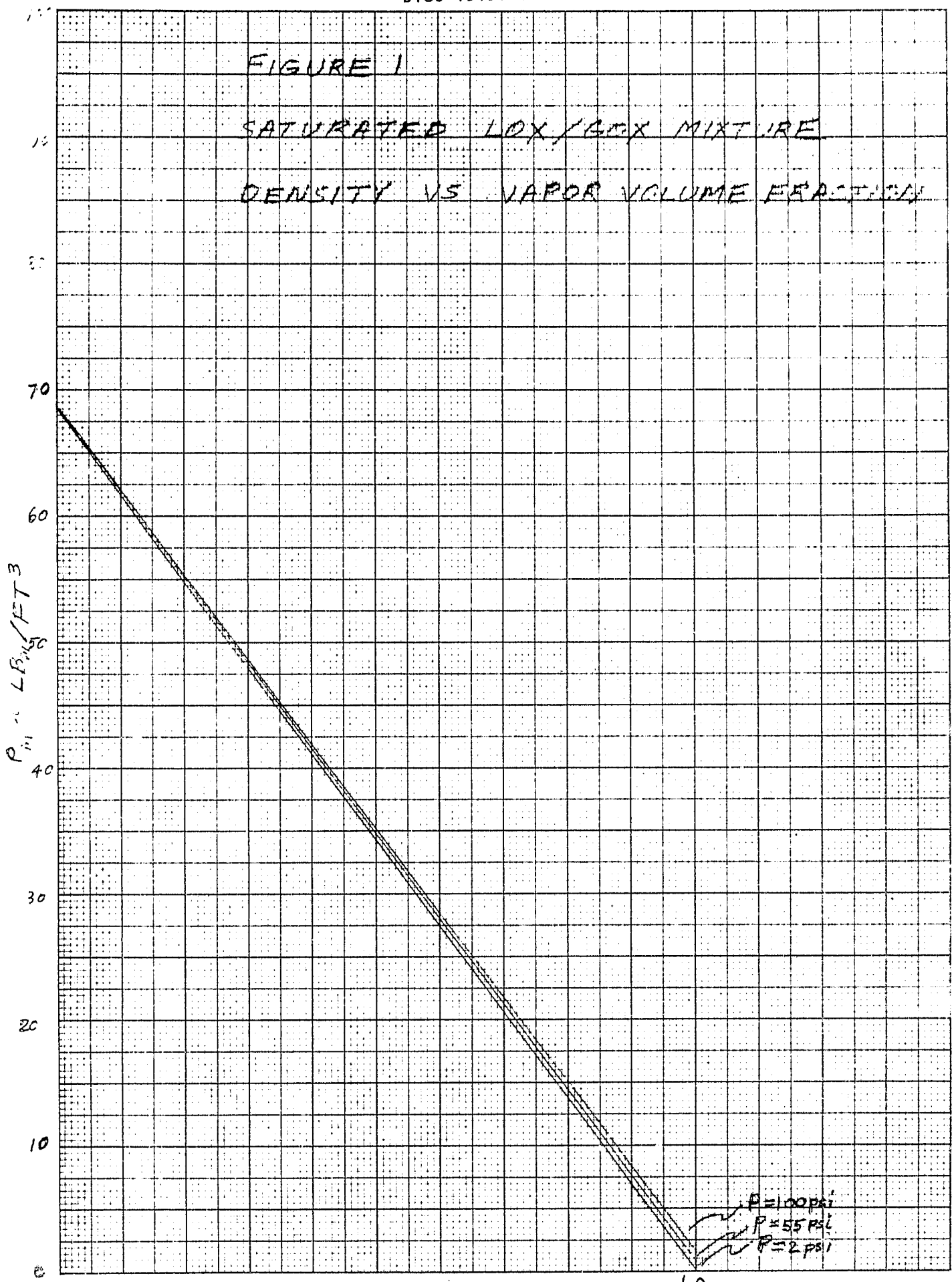

KE 10 X 10 TO 1/2 INCH 46 1323
7 X 10 INCHES MADE IN U.S.A.
KEUFFEL & ESSER CO.

$\alpha = (V_v/V_m)$

NOTE: AT $\alpha = 0$ $\beta_m = 132,000 \text{ psi}$ AT $\alpha = 1.0$ $\beta_v = 166 \text{ PR}$

FIGURE 2
BULK MODULUS FOR SATURATED
LOX/GOX MIXTURE VS
VAPOR VOLUME FRACTION ($\frac{V_v}{V_m}$)

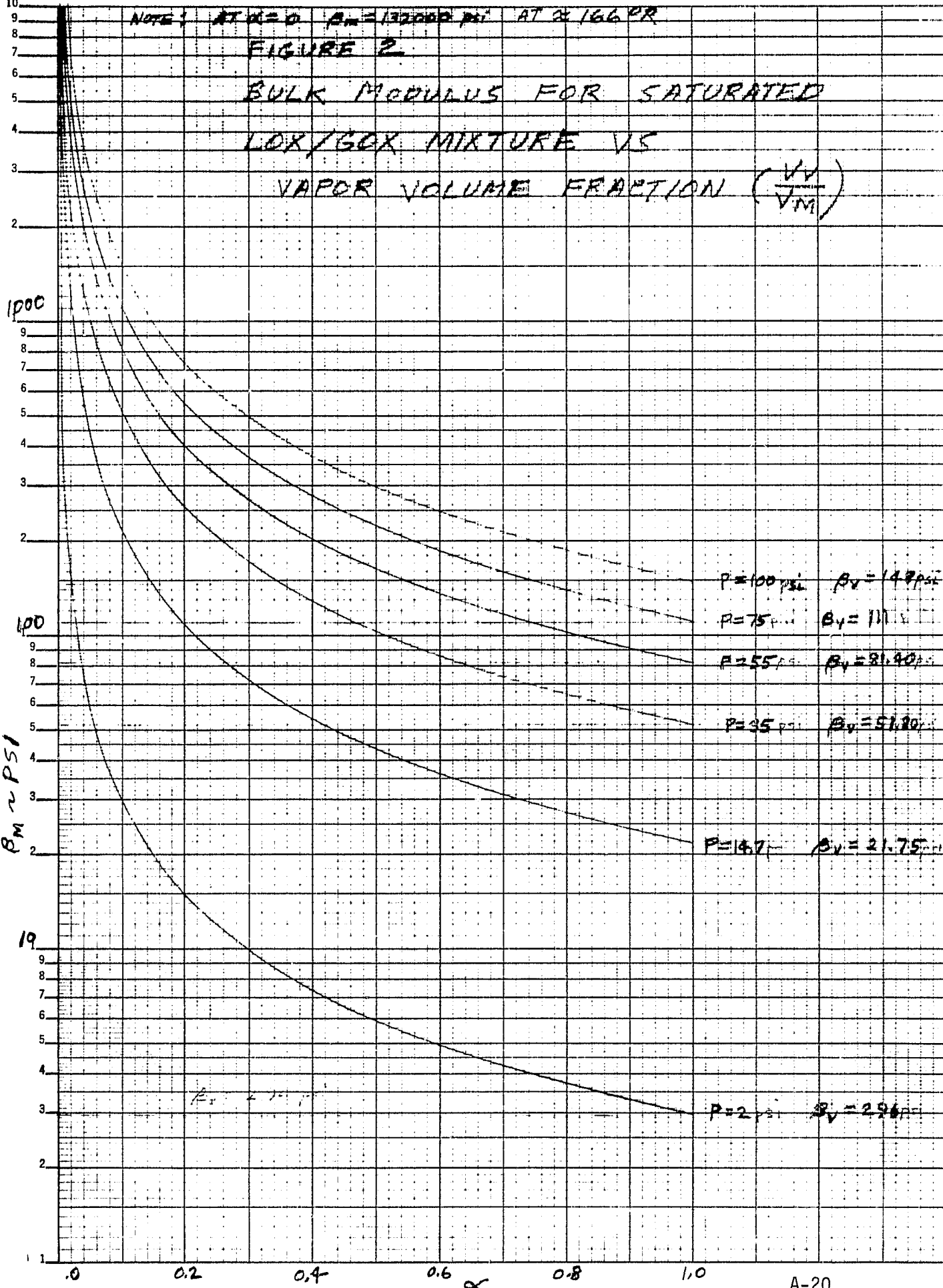

KE SEMI-LOGARITHMIC 46 6013
4 CYCLES X 70 DIVISIONS
MADE IN U.S.A.
KEUFFEL & ESSER CO.

$\beta_m \sim \text{PSI}$

$\beta_m \sim \alpha$

FIGURE 3
 SPEED OF SOUND FOR SATURATED
 LOX/EOX MIXTURE AS A FUNCTION
 OF VAPOR VOLUME FRACTION (V_v/V_g)

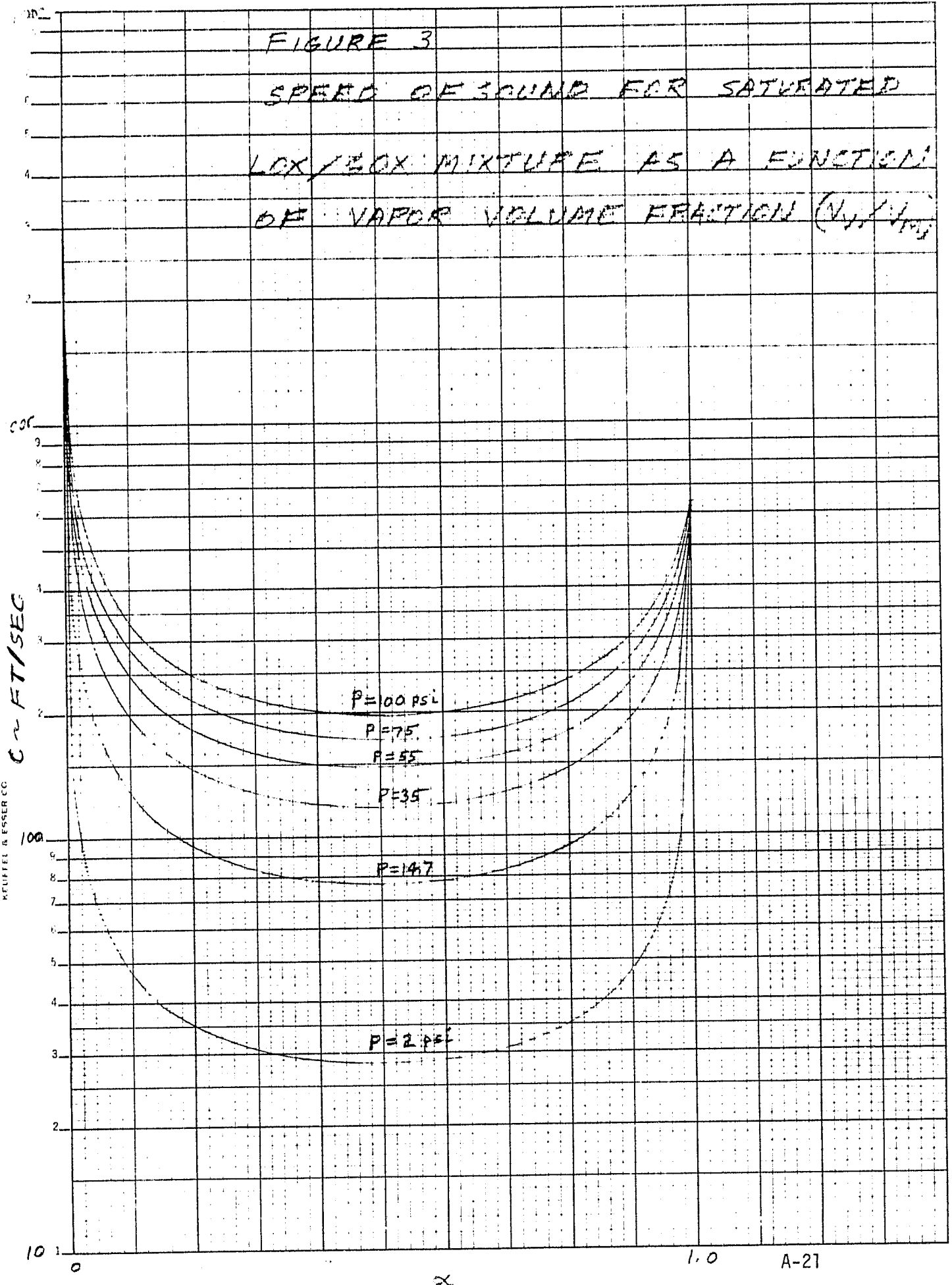

K&E SEMI-LOGARITHMIC 46 5493
 CYCLE, 100 DIVISIONS MADE IN U.S.A.
 KEUFFEL & ESSER CO.

NOTE: at $x=0$, $\frac{m}{A} = 0.0007$ for all pressures

FIGURE 4

CHOKED FLOW RATE PER UNIT AREA
VS VAPOR VOLUME FRACTION (V_v/V_m)
FOR SATURATED LOX/²OX MIXTURE

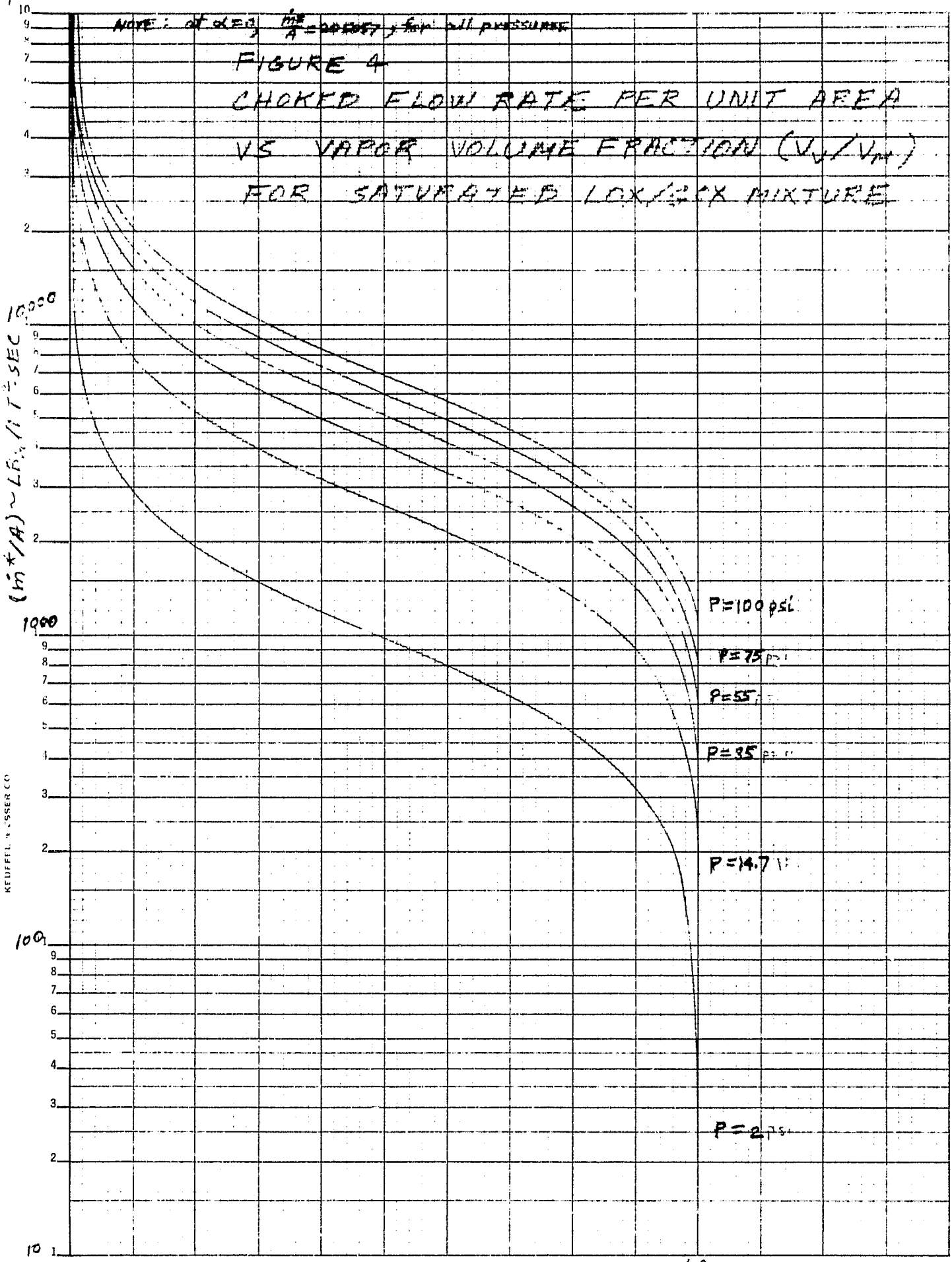

SEMI-LOGARITHMIC 46 6013
4 1/2 x 11 1/2 IN. GRAPH
KIEFFEL & COSSER CO.

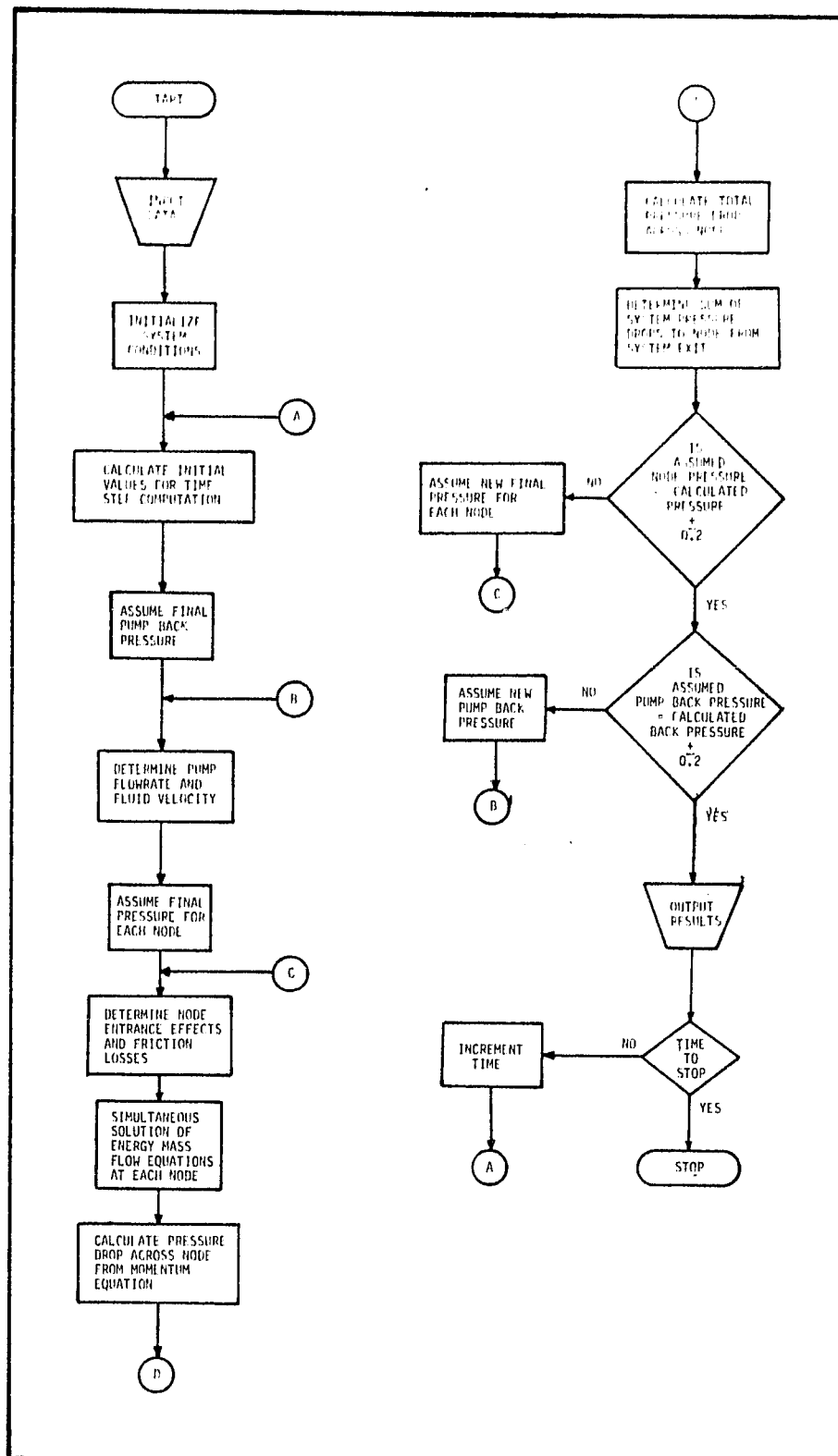

FIGURE 5 TRANSIENT CRYOGEN TRANSFER PROGRAM LOGIC

TRANSIENT CRYOGEN TRANSFER SYSTEM ANALYSIS

4.0 INPUT DATA

The Transient Cryogen Transfer Program (TCTP) requires three sets of card input data. The first two sets of data are in NAMELIST format and the last data set is fixed format input. TCTP also requires a data tape (Internal I/O Unit 10) and scratch disk space (Internal I/O Unit 11) for cases where the restart capability are exercised.

4.1 RESTART DATA TAPE INITIALIZATION

The cryogen transient restart data tape is initialized by writing a single 80 byte record containing the integer value - 1000 as the first word (4 bytes) in the record. Each of the remaining 19 words (76 bytes) should be initialized to zero (or any dummy integer value).

4.2 NAMELIST INPUT DATA

The first data set required for TCTP input is the NAMELIST REST1. REST1 contains the indicators, flags and data required to generate a restart record on the data tape, and/or to restart a case from the data recorded on tape (Restart capability is discussed in Reference 9).

Variables contained in NAMELIST REST1 are:

1. RSTFLG - Logical variable used to indicate whether a restart run is desired. .FALSE. - Nominal run, no restart from existing data. .TRUE. - This run is to be started from data stored on tape.
2. WRSTD - Logical variable used to indicate whether or not a restart data file should be written in this run. .FALSE. - No data is to be written into the library on tape. .TRUE. - Write data into the library on tape.
3. KEYST - Identification integer for data to be used for a restart. Any positive integer is allowed but it is advised that the word be built as follows:

KEYST = NMMIIJJ

where N = Record Number for the data (N = 1-9)

MM = Month (MM = 01-12)

II = Day (II = 01-31)

JJ = Year (JJ = 74)

Thus the third run of June 10, 1974 would have an identification integer

KEYST = 3061074

NOTE: KEYST card not necessary if RSTFLG = FALSE

4.2 (Continued)

4. KEYWR - Identification integer for data to be written into the library on tape. Any positive integer is allowed but it is advised that the word be built as shown in the definition of KEYST.
5. TIMWR - Time to write the data file for this case into the library on tape (SEC).
6. FTIME - Stop time for the current case (SEC). If starting from cards, FTIME is overridden by t_F in fixed format data.
7. VTIME - Time to switch from vent lines to fill lines in the current case (SEC).

The second data set required by TCTP is NAMELIST INPUT. INPUT contains variables required to simulate modulating values, pump inlet pressures, and storage tank mass levels. The variables in NAMELIST INPUT are:

PUMP/INLET PRESSURE

- APIN(I)* - Array of pump inlet pressures for times given in ATPIN, PSIA (maximum of 20 points).
- ATPIN(I)* - Array of times which correspond to the pressures in APIN, SEC (maximum of 20 points).

STORAGE TANK SIMULATION

- AZU(I) - Array of heights in the storage tank referenced to $z=0$. AZU table points correspond to tank volumes in AVZU, FT (maximum of 20 points).
- AVZU(I) - Array of volumes in the storage tank. AVZU table points correspond to tank heights in AZU, FT**3 (maximum of 20 points).
- APU(I) - Array of tank ullage pressures. APU table points correspond to times given in ATPU, PSIA (maximum of 20 points).
- ATPU(I) - Array of times which correspond to ullage pressures given in APU, SEC (maximum of 20 points).
- ATBULK(I) - Array of average bulk temperatures in the storage tank. ATBULK table points correspond to times given in ATTBLK, DEG R (maximum of 20 points).

*TCTP gives the user an option of either direct input of pump inlet pressure or simulation of the storage tank and feedlines. If data for both simulations are included in the NAMELIST data, TCTP automatically defaults to the input values of pump inlet pressure versus time.

4.2 (Continued)

- ATTBLK - Array of times which correspond to bulk temperatures given in ATBULK; SEC (maximum of 20 points).
- NPVZ - Number of table points in AZU.
- ZUI - Initial liquid height in the storage tank referenced to $z=0$ at time zero in the simulation, FT.
- ZTB - Reference elevation of the storage tank exit, FT.

MODULATING VALVE SIMULATION

- NVALVE(I) - Array of external node numbers in which modulating valves are located (maximum of 5 valves per system simulation).
- AVPØS(J,I) - Array of valve positions for each valve corresponding to the times given in ATVPØS. J specifies the table point, I specifies the valve such that NVALVE(I) is the external node number for that valve whose position versus time is given in AVPØS(J,I). The range of AVPØS must correspond to positions given APLØDE. (Maximum J=20, maximum I=5).
- ATVPØS(J,I) - Array of times corresponding to the valve positions given in AVPØS (maximum J=20, maximum I=5).
- APLØDE(J,I) - Array of valve positions which correspond to the $(L/D)_e$ given in ALØDE (maximum J=20, maximum I=5).
- ALØDE(J,I) - Array of equivalent length to diameter ratio for the valve positions given in APLØDE (maximum J=20, maximum I=5).

WINDMILLING PUMP AND SUCTION LINE SIMULATION

- APMDP(I) - Array of differential pressures ($P_{OUT}-P_{IN}$) for pump flowrate calculation during windmilling operation. Pressure data must be input in ascending order (PSID) (Maximum of 20 points)
- APMMDF(I)- Array of pump flowrates corresponding to the differential pressures given in APMDP (LBM/SEC) (Maximum of 20 points)
- NPPMDF - Number of table points in APMDP and APMMDF.
- DPMPIN - Diameter of the pump inlet node (FT).

4.2 (Continued)

- LPMPIN - Length of the pump inlet node (FT).
- ZMPIN - Elevation of the pump inlet (FT).
- FPMPIN - $\Sigma(L/D)_e$ for pump inlet node (actual length/diameter + component $(L/D)_e$ but not including programmable valve).
- AVPPIN(I)- Array of valve positions corresponding to the times given in ATPIN for valve in the pump inlet node. The range of AVPPIN must correspond in magnitude to positions given in APLDPN (Maximum of 20 points).
- ATPIN(I)- Array of times which correspond to valve positions given in AVPPIN (SEC) (Maximum of 20 points).
- APLDPN(I)- Array of valve positions which correspond to the $(L/D)_e$ given in ALDPIN (Maximum of 20 points).
- ALDPIN(I)- Array of equivalent length to diameter ratio for the valve positions given in APLDPN (Maximum of 20 points).

PUMP BY-PASS OR DRAIN LINE FLOW SIMULATION

- BPLODE - $\Sigma 4f_0(L/D)_e$, friction loss coefficient, K_E , for hardware elements and actual line length in the BY-PASS line.
- BPA - Area of the BY-PASS line (FT²).
- BPDZ - Differential height ($Z_{EXIT} - Z_{IN}$) for the BY-PASS line (FT).
- BPPK - BY-PASS line exit static pressure (PSIA).

SPECIAL THROTTLEABLE BY-PASS LINE SIMULATION

Special equations were inserted in the TCTP to simulate throttleable branch flow from a system node to the supply tank reservoir (KSC LOX by-pass) as a function of the system node exit pressure. These equations are labeled "KSC BY-PASS FLOW" in the program, subroutine CALQL8, listing with comment cards. If this simulation is not used, these equations should be removed from the program, or the input data should be set such that the calculated by-pass flow is zero. The required NAMELIST data input for this simulation are:

4.2 (Continued)

ACBP1 - Array of by-pass line flow coefficients ($288g_c A_{BP}^2 / K_E$) corresponding to the times given in ATCBP1 (Maximum of 20 points).

ATCBP1 - Array of times corresponding to the by-pass line flow coefficients (Maximum of 20 points).

NPCBP1 - Number of table points in ACBP1.

If this simulation is used, the internal node numbers at the by-pass exit and the next two downstream nodes and the differential height ($Z_{EXIT} - Z_{IN}$) for the by-pass line must be inserted directly in Subroutine CALQL8 code to calculate the by-pass flow as discussed in paragraph 2.4.2.

SPECIAL SYSTEM BLEED FLOW SIMULATION

Special equations were inserted in the TCTP to simulate a bleed flow from the system at a given node exit as a function of the mode exit pressure. These equations are labeled "KSC BLEED FLOW", "SPECIAL EQUATIONS TO SIMULATE ENGINE BLEED", "BLEED FLOW", and "KSC BLEED FLOW" in the program listing (Subroutine CALQL8). If this simulation is not used, these cards should be removed from the program, or by-passed with bleed flow set to zero. If this simulation is used, the following must be inserted directly into Subroutine CALQL8 code to calculate the bleed flow as discussed in paragraph 2.4.2.

- (1) Internal node numbers at the bleed flow exit and the next two downstream nodes.
- (2) Bleed flow exit (vent line) pressure.
- (3) Bleed flow system differential height constant ($Z_{EXIT} - Z_{IN}$)/144.
- (4) Bleed flow system flow coefficient ($288 g_c A_{BL}^2 / K_E$).

PUMP PERFORMANCE SIMULATION OPTION

An option has been incorporated in the program to compute required pump speed as a function of input system entrance flow rate and computed pump discharge pressure instead of computing system entrance flow rate as a function of input pump speed and computed pump discharge pressure (paragraph 2.4.1). In order to exercise the option to input pump flow rate instead of pump speed, the required NAMELIST data are:

4.2 (Continued)

- MDPUMP = 1 Option to input pump discharge flow rate as a function of time. The program will determine required pump speed as a function of pump flow rate and pressure rise.
- MDPUMP = 0 Option to input pump speed (RPM) as a function of time. The program will determine pump flow rate as a function of pump speed and pressure rise.
- AMDF1 Array of pump discharge flow rates corresponding to the times given in ATMDF1 (Maximum of 20 points).
- ATMDF1 Array of times corresponding to the pump flow rates (maximum of 20 points).

If no values of pump flow rate are input, the program will default to MDPUMP = 0.

4.3 FIXED FORMAT INPUT DATA

The fixed format input data are given in three logical sections and set up in the following order:

Section 1	System Constants
Section 2	Nodal Data
Section 3	Tables

Unless otherwise noted, all values are floating point values and may be keypunched anywhere in the indicated card field (columns).

Integer values must be right adjusted in their fields.

A blank field (no punches in the field) is equivalent to a zero (integer or floating point).

4.3.1 Section 1 - System Constants

<u>CARD</u>	<u>COLUMNS</u>	<u>CONTENTS</u>
1	1-70	Title - one to seventy alphanumeric characters (including blanks) to be used as a print title

4.3.1 (Continued)

<u>CARD</u>	<u>COLUMNS</u>	<u>CONTENTS</u>
2	1-10	Δt - time increment (sec)
	11-20	t_F - final time (sec). If restarting from tape, t_F is overridden by FTIME NAMELIST data.
	21-30	t_v - vent close time (sec)
	31-40	Δt_p - print time increment (sec)
	41-50	print option (integer) = 0 - do not print optional data = 1 - print optional data
3	1-10	BLANK SPACE - NOT USED
	11-20	g - system acceleration (ft/sec ²)
	21-30	μ_V - vapor viscosity (lb(mass)/ft-hr)
	31-40	μ_L - liquid viscosity (lb(mass)/ft-hr)
	41-50	K_V - vapor thermal conductivity (BTU/ft-hr-°R)
	51-60	K_L - liquid thermal conductivity (BTU/ft-hr-°R)
4	1-10	β_L - liquid bulk modulus (psi)
	11-20	P_{RV} - vapor Prandtl number
	21-30	P_{RL} - liquid Prandtl number
	31-40	C_{pL} - liquid specific heat (BTU/LB(Mass)°R)
	41-50	C_{pV} - vapor specific heat at constant pressure (BTU/Lb(Mass)°R)
	51-60	C_{vV} - vapor specific heat at constant volume (BTU/lb(mass)°R)
5	1-10	N_p - pump external node number (integer)
	11-20	N_T - transfer line low and high external node numbers (integers)
	21-30	
	31-40	N_V - vent line low and high external node numbers (integers)
	41-50	
	51-60	N_F - fill line low and high external node numbers (integers)
61-70		

4.3.1 (Continued)

<u>CARD</u>	<u>COLUMNS</u>	<u>CONTENTS</u>
6	1-10 11-20 21-30 31-40 41-50 51-60 61-70	external node numbers (integers) of the nodes for which print is desired. One to seven node numbers per card (zero node numbers are ignored). Repeat this card until all nodes are given. To print all nodes omit this card(s). (Maximum of 50 input values).
7	1-70	Blank - a blank card to signal the end of print nodes input.

4.3.2 Section 2 - Nodal Data

<u>CARD</u>	<u>COLUMNS</u>	<u>CONTENTS</u>
1	1-10 11-20 21-30 31-40 41-50 51-60 61-70	N - external node number (integer) D_N - diameter (ft) L_N - length (ft) Z_N - elevation (ft) q_{EXT_N} - external heat rate (BTU/ft ² sec) at $T_N - T_1$ K_{AN} - Loss coefficient for area change T_{NI} - initial temperature (°R) if a zero or negative value is given, the program will calculate saturated T_{NI} as a function of p_{wi} using Table 2
2	1-10 11-20 21-30 31-40 41-50 51-60 61-70	A_{NW} - Actual inside heat transfer surface area if different from $\pi D_N L_N$. P_{NI} - initial pressure (psi(abs)) X_{NI} - initial bulk quality $\Sigma(L/D)$ for node(actual length/diameter + component (L/D)e $M_{WN} * C_{WN}$ - wall mass * wall specific heat MDF_N - initial flow rate, Input -1 if program calculation is desired. TW_{NI} - Initial wall temperature. Input (-1) if program calculation is desired for steady state initial conditions.
3	1-70	blank - a blank card to signal the end of nodal data

ORIGINAL PAGE IS
OF POOR QUALITY

4.3.2 (Continued)

Cards 1 and 2 are repeated for each node. Card 3 follows card 2 of the last node.

The nodes do not have to be given in any order. The program will sort them by line section, and by node number, and assign internal node sequencing.

No external node number may be zero or negative.

4.3.3 Section 3 - Tables

The following tables are used in the TRANSIENT CRYOGEN TRANSFER PROGRAM.

Table #1 Vapor density as a function of pressure and temperature

$$\rho_V = f_1(p, T)$$

Table #2 Saturation temperature as a function of pressure

$$T_S = f_2(p)$$

Table #3 Vapor saturation internal energy as a function of temperature

$$U_{VS} = f_3(T_S)$$

Table #4 Saturated liquid internal energy as a function of temperature

$$U_{LS} = f_4(T)$$

Table #5 Friction factor correction as a function of vapor volume

$$\left(\frac{f_{TP}}{f_0}\right) = f_5(1-\alpha)$$

Table #6 Single phase friction factor as a function of two phase Reynolds' number

$$(f_{0F}) = f_6\left(\frac{\rho V D}{\mu}\right)$$

Table #8 Exit node pressure as a function of time

$$p_K = f_8(t)$$

4.3.3 (Continued)

Table #9 (Pump flow rate/RPM) as a function of (pressure, RPM²)

$$\left(\frac{\dot{M}}{\text{RPM}}\right) = f_9 \left(\frac{P_{\text{OUT}} - P_{\text{IN}}}{\text{RPM}^2}\right)$$

Table #10 Pump RPM as a function of time

$$\text{RPM} = f_{10}(t)$$

Table #11 Pump discharge temperature as a function of time - Input 1 if pump is "windmilling"

$$T = f_{11}(t)$$

The table input cards have the following columns and content.

<u>CARD</u>	<u>COLUMNS</u>	<u>DATA</u>
3.1	1-10	Table numbers
	11-20	<p>T_B - Built in table type - Tables #1 to #4 have been built into the program for various types of fluid. Tables #5 and #6 have been built in also. When a built in table is to be used, T_B is a number defining the types of fluid. (Tables #1 to 4)</p> <p>$T_B = 1$ - LOX</p> <p>$T_B = 2$ - Liquid H₂ (future addition)</p> <p>For tables #5 and #6 $T_B = 1$</p> <p>NOTE: set $T_B = 0$ to read the table from cards.</p>
	21-30	N_M - BLANK SPACE - NOT USED
	31-40	N' - BLANK SPACE - NOT USED
	41-50	X values scale factor

4.3.3 (Continued)

<u>CARD</u>	<u>COLUMNS</u>	<u>DATA</u>
	51-60	Y values scale factor
	61-70	Z values scale factor

When the table is given on cards, it may be convenient to scale the values for two dimensional tables, the X scale factor scales the independent values and the Y scale factor the dependant variables. For three dimensional the X and Y scale factors scale the independent variables, the Z scale factor the dependent variable. In all cases the scaling is (desired value) = (scale factor) times (input value). For tables #1 to #6 when T_B is given, Card 3.1 is all that is required as input.

3.2 For two dimensional tables only (tables #2, #4, #5, #6, #7 (all nodes), #8, #9, #10, and #11)

11-20	X_1 - the independent value
21-30	Y_1 - the dependent value at X_i
31-40	X_2
41-50	Y_2
51-60	X_3
61-70	Y_3

NOTE: The values are given in pairs. If the card columns for any pair are left blank, or both values are zero, then the pair is discarded. To obtain a true zero-zero pair, input one value very small (i.e. $1.0E - 60$). At least one pair must be given on each card.

3.3 to 3.K-1 Repeat card 3.2 as necessary to input the full table

D180-19190-1

4.3.3 (Continued)

<u>CARD</u>	<u>COLUMNS</u>	<u>DATA</u>
3.K		One blank card
3.2		For three dimensional tables only (tables #1 and #3)
	11-20	X_1 - first independent value
	21-30	Y_1 - second independent value
	31-40	Z_1 - dependent values at X_1, Y_1
	41-50	X_2
	51-60	Y_2
	61-70	Z_2

NOTE: The values are given in sets of three. If the card columns for any set are left blank or all values of the set are zero then the set is discarded. To obtain a true zero-zero-zero set, input one value very small (i.e., $1.0 \text{ E-}60$). At least one set must be given on each card.

3.3 Repeat card 3.2 as necessary to input the full table to K

3K One blank card

Card 3.1 must be given for each table. If not given for tables #1, #2, #3, #4, #5, or #6 the built-in table(s) will be used. To default to a fluid other than LOX, use a card 3.1 with the table numbers = 0, and the types of fluid (T_B) set for the fluid desired. Table #7 is not needed for all nodes. For the nodes for which a table #7 is not given a value of $K_E = 0$ will be used at computation time.

Cards 3.2 to 3.K must be given for each table unless the value of T_B (tables #1 to 6 and #12) or the value of N' (table #7 only) indicate otherwise in which case cards 3.2 to 3.K must be omitted.

Card 3.K is required for all tables when the values are given as input (card 3.2 etc.). Tables may be given in any order.

4.3.4 Deck Sequencing

Card Columns 71 to 80 are not used by the program, and therefore can be used for deck sequencing. A suggested method of sequencing is as follows:

<u>COLUMNS</u>	<u>VALUE</u>
72	Section number
74-75	Table number (section 3 only)
77-79	Node numbers (section 2)
80	Card number

4.4 PARALLEL AND BRANCH FLOW VERSION OF TCTP

During the SSME Feasibility Study (Reference 11), a special version of TCTP was developed to simulate systems with multiple flow paths. This version of TCTP will incorporate either oxygen or hydrogen as the working fluid by setting the fluid type indicator to one or two, respectively, and automatically processes multiple flow paths if the input data are arranged according to the rules set forth in this section.

The following definitions are basic to the multiple flow path version of TCTP:

Main Flow Leg	An arbitrarily chosen flow path through a system. This path must start at the system supply point (usually a pump) and terminate at a plenum which is outside the system. The pressure in the plenum may be constant or time variant.
Parallel Flow Leg	A flow path which emanates from a point in the main flow leg and terminates into a different point in the main flow leg.
Branch Flow Leg	A flow path which emanates from a point in the main flow leg and terminates into a plenum. The pressure in the plenum may be constant or time variant, but the plenum must be external to the system.

4.4 (Continued)

Mixing Region Junction points of the main flow leg and branch leg entrances and/or parallel leg entrances and exits. Mixing regions are always located at the downstream (away from the system supply node) end of a main flow leg node. One mixing region may contain one or a combination of entrances and/or exits.

The following rules must be adhered to in formulation of the system description for input to TCTP:

- 1) The maximum number of legs will be six per system: one main flow leg and any combination of five (or less) parallel and branch legs. The minimum system description shall contain at least one leg: the main flow leg.
- 2) All branch and parallel flow legs will emanate from the main flow leg; parallel legs will terminate into the main leg.
- 3) No nested parallel flow paths are allowed; each parallel leg must be terminated before another parallel leg is initiated along the main leg.
- 4) Branch and parallel legs may be initiated at any node in the main flow leg with the exception of the system supply node and the system exit node (first and last nodes).
- 5) A minimum of two nodes shall be placed in each parallel or branch leg.

The nodal data required for the physical description of each node in the system are identical to those given in Section 2 (cards 2.1 and 2.2). However special instructions are required in assigning node numbers for the system. The node numbers must be assigned in ascending order from the system supply node to the main leg exit, then node numbers for the first leg in ascending order, node numbers for the second leg, etc. All numerical values assigned as node numbers are arbitrary but must be assigned in ascending values. Leg node numbers must always be larger than the main leg exit node numbers and must be grouped by legs. Numerical values for leg node numbers must fall within the "vent" range as identified by card 1.5.

The following variables are input in NAMELIST format using NAMELIST INPUT:

NLEGS Number of flow legs in the system including the main flow leg. (NLEGS.GE.1)

4.4 (Continued)

- LENT(I) Node number for the main flow leg node which is the supply node for a parallel or branch leg. (NOTE: legs always exit from the downstream end of a main flow leg node). LENT(1)=the pump node number, I=leg number.
- LEXT(I) Node number for the main flow leg node into which a parallel leg terminates. LEXT(1)=the last node in the main flow leg. LEXT(I) is input .LE.0 for branch flow legs. I=leg number.
- LEG(I) Node number of the first node in each leg of a system. LEG(1) = pump node number. LEG(I), I.GT.1, should always be greater than LEXT(1) and all node numbers for leg I should be less than LEG(I+1); node numbers in the last leg node should be less than NVENT(2) (card 1.5). All LEG(I) values must fall into the range $NVENT(1) < LEG(I) < NVENT(2)$ for $I > 1$. I=leg number.
- ATPK(J,I) Array of times corresponding to pressures given in APK(J,I) (seconds). I=leg number, J=table point number (maximum of 20 points per leg).
- APK(J,I) Array of plenum pressures for the main leg and all branch legs corresponding to the times given in ATPK (J,I). (PSIA) I=leg number, J=table point number (maximum of 20 points per leg).
- NPPK(I) Number of points in the APK(J,I) array. I=leg number.

Mixing regions are automatically assigned for each leg entrance and exit. (No mixing region is assigned for leg one). Three coordinates are defined at each mixing region as follows:

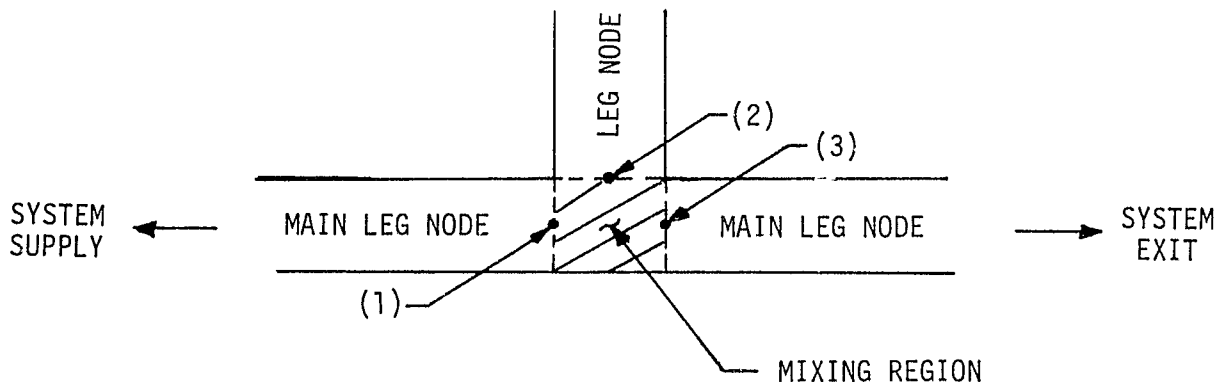

4.4 (Continued)

These coordinates are used to identify flowrate, enthalpy and density crossing the boundaries of the mixing region at a leg entrance or exit. When combinations of entrances and/or exits exist at mixing region, initial values for flowrate at boundaries (1) and (3) are input as total values for each leg. The following variables are input via NAMELIST INPUT and conform to this coordinate convention:

- MDFSP(K,I) - Initial flowrates crossing boundaries of a mixing region for a parallel or branch leg entrance. Flows are positive left to right for main leg nodes. Flows are positive entering a leg; negative if they are being expelled from the leg at the entrance. (LB_M/SEC). I=leg number, K=coordinate.
- HPTSP(K,I)* - Initial Enthalpy of fluid crossing boundaries of a mixing region for a parallel or branch leg entrance (BTU/LB_M). I=leg number, K=coordinate.
- RHØSP(K,I) - Initial density of fluid crossing boundaries of a mixing region for a parallel or branch leg entrance (LB_M/FT^3). I=leg number, K=coordinate.
- MDFSPI(K,I) - Initial flowrates crossing the boundaries of a mixing region for a parallel leg exit. Main leg node flows are positive left to right. Flow being expelled from a parallel leg into the mixing region is positive. (LB_M/SEC). I=leg number, K=coordinate.
- HPTSPI(K,I)* - Enthalpy of fluid crossing boundaries of a mixing region for a parallel leg exit (BTU/LB_M). I=leg number, K=coordinate.
- RHØSPI(K,I) - Density of fluid crossing boundaries of a mixing region for a parallel leg exit (LB_M/FT^3). I=leg number, K=coordinate.

*Enthalpy for hydrogen must be defined in a manner consistent with NBS-TN-617 (Reference 12). Oxygen enthalpy must be defined on a base consistent with NASA SP-3071 (Reference 13).

D180-19190-1

4.4 (Continued)

An example of a system with parallel and branch legs is shown schematically in Figure 6. A card image of the input data deck is given in Figure 7.

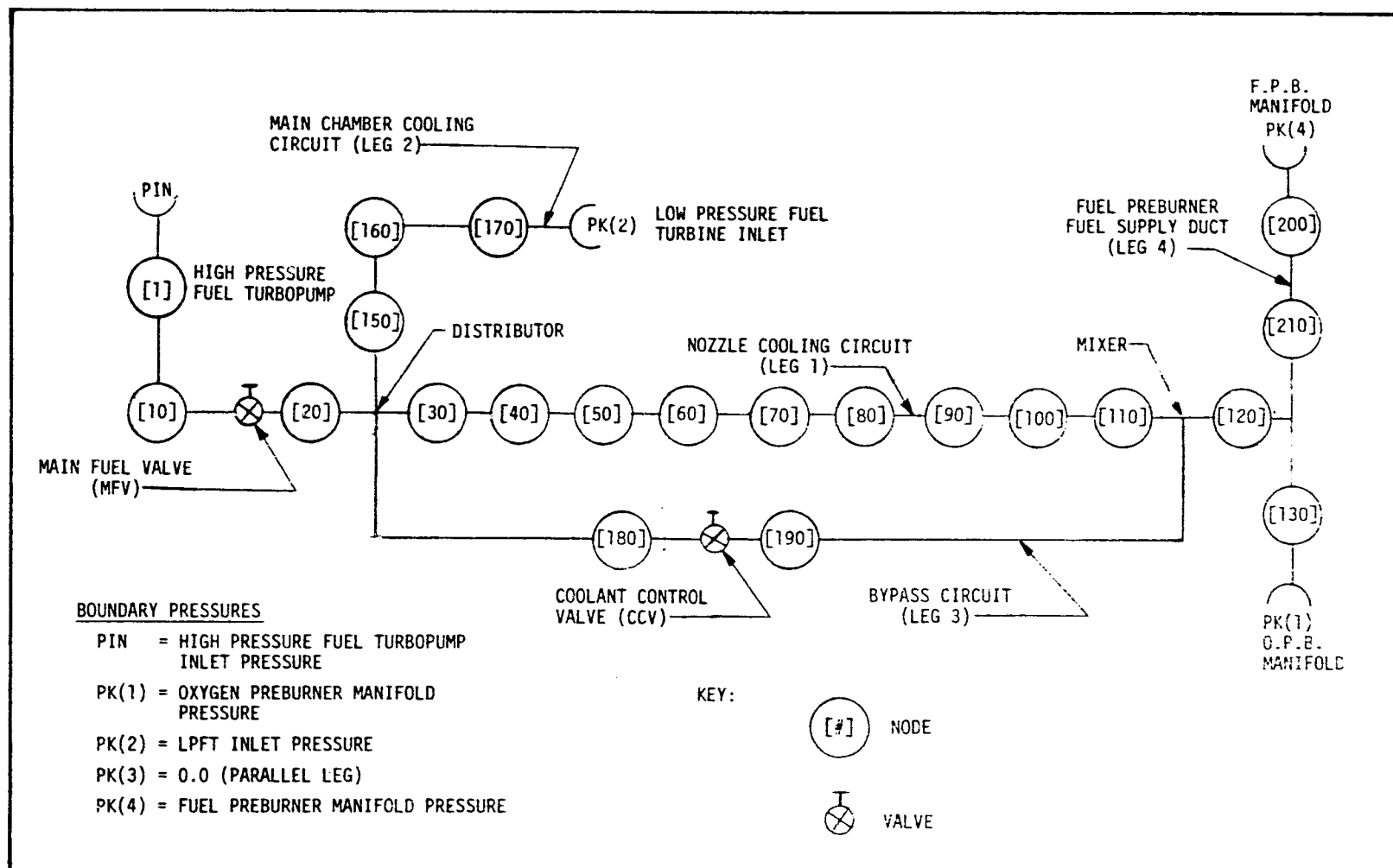

FIGURE 6 SSME HYDROGEN SYSTEM SCHEMATIC WITH TCTP NODES IDENTIFIED

```

CARD IMAGE OF INPUT DATA

CHEST1
RSTPLG=.FALSC.,
PKSTP=.TRUP.,
TIMPK=.400/50.,
KEYPK=1111475.,
FTIME=600.,
VTIME=10000.,
LENG
LINPUT
ATPK(1,1)=0.0, .1, .2, .3, .4, .5, .6, .7, .8, .9, 1.1, 1.1, 1.2, 1.3, 1.4, 1.5, 1.6, 1.7, 1.8,
ATPK(1,2)=0.0, .1, .2, .3, .4, .5, .6, .7, .8, .9, 1.1, 1.1, 1.2, 1.3, 1.4, 1.5, 1.6, 1.7, 1.8,
ATPK(1,4)=0.0, .1, .2, .3, .4, .5, .6, .7, .8, .9, 1.1, 1.1, 1.2, 1.3, 1.4, 1.5, 1.6, 1.7, 1.8,
APK(1,1)=2414.7, 14.9, 18.8, 26.3, 35.4, 44.1, 50.0, 40.7, 37.0, 59.2, 92.1, 103.1, 145.2,
179.9, 206.0, 404.2, 715.4, 1729.4,
APK(1,2)=14.7, 14.70, 14.70, 18.90, 21.40, 24.02, 29.00, 32.09, 28.87, 28.66, 40.30,
60.13, 64.21, 94.32, 122.40, 178.73, 274.75, 603.33, 1219.70,
APK(1,4)=2414.7, 14.9, 18.8, 26.3, 35.4, 44.1, 50.0, 40.7, 37.0, 59.2, 92.1, 103.1, 145.2,
182.2, 271.1, 420.9, 911.4, 1720.6,
NPPK(1)=14,
NPPK(2)=14,
NPPK(4)=14,
NVALVC(1)=20, 190,
APLDE(1,1)=0.0, 35.714, 30.095, 40.475, 42.057, 45.238, 47.619, 52.301, 59.524, 66.667,
APLDE(1,1)=76.190, 83.333, 88.095, 92.857, 97.619, 100.0,
ALRDE(1,1)=242380210., 545053., 218186., 104093., 14877., 38678., 16248., 5554.,
ALRDE(10,1)=3570., 1190., 436., 194., 75., 28., 12.,
APLDE(1,2)=0.0, 3.2, 12.5, 20.625, 30., 42.5, 52.5, 62.5, 75., 80., 85., 90., 97.5, 100.,
ALRDE(1,2)=47467., 234234., 105263., 47847., 20574., 7895., 3349., 1579., 622., 359.,
201., 115., 43., 31.,
ATVPS(1,1)=0.0, 0.34, 0.65, 0.66, 10.0,
AVPDS(1,1)=0.0, 49., 94.7, 295.7,
ATVPS(1,2)=0.0, 10.0,
AVPDS(1,2)=2492.5,
ATPIN(1)=0.0, .1, .2, .3, .4, .5, .6, .7, .8, .9, 1.1, 1.1, 1.2, 1.3, 1.4, 1.5, 1.6, 1.7, 1.8,
ATPIN(1)=241.34, 41.65, 41.24, 41.20, 2.06, 3.53, 43.31, 36.50, 37.12, 42.06, 48.37,
35.17, 34.48, 32.31, 39.20, 29.17, 20.64, 37.73,
NLEGS=4,
LENT(1)=1, 20, 20, 120,
LEXT(1)=130, 0, 110, 0,
LEG(1)=1, 150, 180, 200,
MHSP(1,1)=180.0,
HPTSP(1,1)=6*1735.408,
HPTSP(1,2)=6*1735.466,
HPTSP(1,3)=6*1735.408,
MHSP(1,1)=6*0.00531,
MHSP(1,2)=6*0.00531,
MHSP(1,3)=6*0.00531,
MHSP(1,1)=1300.0,
HPTSP(1,1)=13*1735.466,
MHSP(1,1)=180.00531,
BPA=0.0,
BPPK=1000000.,
BPPIN=0.0,
BPDZ=0.0,

END
SSHE H2 SYSTEM FEASIBILITY STUDY CASE 1 11/18/75
    
```

FIGURE 7 CARD IMAGE OF INPUT DATA FOR SSME HYDROGEN SYSTEM

ORIGINAL PAGE IS
OF POOR QUALITY

D180-19190-1

0.15023	1.0	100000.0	0.015625	0.01539	0.05616	1	2
	32.174	0.03116	0.02020	0.01539	0.05616	1	3
0.00000	1.00000	1.00000	0.772	0.30	1.000	1	6
	1	2	25	50	220	230	250
	1	2	25	50	220	230	250
	1	2	25	50	220	230	250
0.0	14.7	0.0	0.0	0.0	0.0	34.66	2
	42.53	0.0	0.0	0.0	0.0	34.66	2
0.0	13	0.2833	2.56	0.0	0.0245	0.0	2
	14.7	1.0	229.21	0.774	0.0	-1.0	2
0.840	20	0.2729	0.7723	0.0	1.342	0.0	2
	14.7	1.0	229.21	0.774	0.0	-1.0	2
5.770	30	0.1375	4.009	0.0	1.342	0.0	2
	14.7	1.0	47.97	1.464	0.0	-1.0	2
5.770	40	0.1375	4.009	0.0	1.342	0.0	2
	14.7	1.0	47.97	1.464	0.0	-1.0	2
6.521	50	0.2053	3.43	0.0	1.342	0.0	2
	14.7	1.0	24.72	5.919	0.0	-1.0	2
6.521	60	0.2053	3.43	0.0	1.342	0.0	2
	14.7	1.0	24.72	5.919	0.0	-1.0	2
101.63	70	0.33702	2.5435	0.0	1.342	0.0	2
	14.7	1.0	962.54	2.913	0.0	-1.0	2
101.63	80	0.33702	2.5435	0.0	1.342	0.0	2
	14.7	1.0	962.54	2.913	0.0	-1.0	2
101.63	90	0.33702	2.5435	0.0	1.342	0.0	2
	14.7	1.0	962.54	2.913	0.0	-1.0	2
2.934	100	0.25	3.6979	0.0	1.342	0.0	2
	14.7	1.0	52.595	4.780	0.0	-1.0	2
3.33	110	0.25	4.0665	0.0	1.342	0.0	2
	14.7	1.0	56.89	4.997	0.0	-1.0	2
0.0	120	0.30	1.539	0.0	1.342	0.0	2
	14.7	1.0	20.50	0.540	0.0	-1.0	2
0.0	130	0.1667	4.43	0.0	1.342	0.0	2
	14.7	1.0	54.62	0.970	0.0	-1.0	2
0.0	150	0.12405	11.0793	0.0	1.342	0.0	2
	14.7	1.0	303.1154	3.36294	0.0	-1.0	2
0.0	160	0.166667	6.449	0.0	1.342	0.0	2
	14.7	1.0	1801.32	5.7186	0.0	-1.0	2
0.0	170	0.16667	5.8788	0.0	1.342	0.0	2
	14.7	1.0	65.6835	6.6334	0.0	-1.0	2
0.0	180	0.20575	6.2959	0.0	1.342	0.0	2
	14.7	1.0	28.1642	1.1082	0.0	-1.0	2
1.51951	190	0.191266	1.98244	0.0	1.342	0.0	2
	14.7	1.0	55.153	0.8410	0.0	-1.0	2
0.0	200	0.3107	1.806	0.0	1.342	0.0	2
	14.7	1.0	42.42	0.7003	0.0	-1.0	2
0.0	210	0.3167	1.227	0.0	1.342	0.0	2
	14.7	1.0	42.42	1.0773	0.0	-1.0	2
0.0	240	0.3167	1.227	0.0	1.342	0.0	2
	14.7	1.0	42.42	1.0773	0.0	-1.0	2
							3
							5
							1
							3
							5
							1
							3
							5
							1
							3
							5
							1
							3
							5
							1
							3
							5
							1
							3
							5

FIGURE 7 CARD IMAGE OF INPUT DATA FOR SSME HYDROGEN SYSTEM (CONTINUED)

8							3 8	7
	14.7	1000.0	14.7				3 8	1
							3 8	2
9				1.0E-6	1.0E-4		3 9	1
	0.00	-100.0	0.00	0.0	4.00	14.0	3 9	2
	4.01	20.0	4.00	0.0	4.01	30.0	3 9	3
	0.00	40.0	0.00	0.0	2.00	10.0	3 9	4
	1.00	0.00	1.00	0.0	1.00	57.0	3 9	5
	1.00	0.00	1.10	0.0	0.70	00.0	3 9	6
	0.00	01.0	0.00	01.0			3 9	7
10							3 9	8
	0.0	0.1	0.521	01.00	0.01	650.5	3 10	1
	0.71	1102.0	0.71	1000.0	0.71	1930.0	3 10	2
	1.01	2000.0	1.01	3000.0	1.21	4192.0	3 10	3
	1.31	5000.0	1.41	0400.0	1.51	7513.0	3 10	4
	1.61	10244.0	1.71	17000.0	1.81	24535.0	3 10	5
							3 10	6
							3 10	7
11							3 11	1
	0.50	30.00	0.50	30.00	0.40	30.50	3 11	2
	0.50	30.19	0.62	30.00	0.70	30.50	3 11	3
	0.70	30.90	0.90	30.11	1.20	30.90	3 11	4
	1.20	30.00	1.30	39.14	1.40	39.14	3 11	5
	1.50	30.90	1.61	39.40	1.70	42.00	3 11	6
	1.70	40.54	1.80	55.20			3 11	7
							3 11	8

FIGURE 7 CARD IMAGE OF INPUT DATA FOR SSME HYDROGEN SYSTEM (CONTINUED)

ORIGINAL PAGE IS
OF POOR QUALITY

D180-19190-1

STEADY STATE CRYOGEN TRANSFER SYSTEM ANALYSIS

1.0 CONTROLLING EQUATIONS

Many of the equations used in the steady state program are identical to those given in Attachment 1 for the transient program. Therefore, for convenience the additional steady state equations will be numbered consecutively with the equations in Attachment 1.

For steady state conservation of energy, equation (4) reduces to,

$$h'_N = h'_{N-1} + \frac{gz_{N-1}}{gcJ} + \frac{v_{N-1}^2}{2gcJ} + \frac{q_{EXT}}{M} - \frac{gz_N}{gcJ} + \frac{v_N^2}{2gcJ} \quad (33)$$

For conservation of momentum, equation (5) reduces to,

$$P_N - P_{N-1} = \frac{\rho_{N-1} v_{N-1}^2 - \rho_N v_N^2}{144 gc} - \rho_N \left[\frac{g}{144 gc} (Z_N - Z_{N-1}) \right] - \Delta P_{FN}. \quad (34)$$

STEADY STATE CRYOGEN TRANSFER SYSTEM ANALYSIS

2.0 SUBSIDIARY EQUATIONS

In addition to the fluid property equations given in Attachment 1, the one-phase ($X_N = 0$ or 1) node temperature is determined as a function of enthalpy,

$$T_N = T_{SN} - \frac{h_S - h'_N}{C} \quad (35)$$

where $h_S = h_{VS}$ and $C = C_{PV}$ for $X_N = 1$

and $h_S = h_{LS}$ and $C = C_{PL}$ for $X_N = 0$

The node quality is determined as a function of the exit enthalpy at the assumed node pressure. If the node exit enthalpy is between the saturated liquid and vapor values ($h_{LS} < h'_N < h_{VS}$)

$$X_N = \frac{h'_N - h_{LS}}{h_{VS} - h_{LS}} \quad (36)$$

$$\text{if } h'_N < h_{LS}, X_N = 0 \quad (37)$$

$$\text{and if } h'_N > h_{VS}, X_N = 1.0 \quad (38)$$

STEADY STATE CRYOGEN TRANSFER SYSTEM ANALYSIS

3.0 SYSTEM ANALYSIS

After the known system conditions and geometry are established, the procedure outlined on Figure 8 is utilized to determine the steady state flow rate corresponding pump RPM, node properties and pressure gradient. Originally, the program computed both the node bulk average quality, X_N , and the local quality leaving the node, X'_N , and corresponding values of density and vapor volume fraction. However, in the current program, the node bulk and exit qualities are considered to be equal. Therefore, the redundant equations for bulk and local values of density and vapor volume fraction could be eliminated with some program nomenclature changes.

The pump discharge flow entering the transfer system is assumed to be subcooled at the input values of temperature and pressure.

The pump exit density is set equal to the saturated liquid density for the given cryogen, and the saturated internal energy is determined from an input table as a function of input temperature. The pump exit enthalpy is determined from equation (32). The quality and vapor volume fraction entering the transfer system are set equal to zero, and the velocity is determined from equation (3) for the assumed flow rate.

Since the hydrostatic head, two-phase frictional pressure drop, and momentum flux are functions of the fluid quality and the quality is a function of flow rate, an iterative solution is required to determine the steady state flow rate for the known entering and exit node pressures and system external heat flux.

A "DO LOOP" is used for consecutive nodes, 2 through K where K is the system exit node, to determine each node pressure, thermodynamic state, and exit velocity. Therefore, when entering the "DO LOOP" for a given node, the flow conditions and enthalpy leaving the upstream node are known. If the flow area changes at the node entrance, the velocity entering the node is determined from equation (6) and the entrance pressure loss ($P'_{N-1} - P_{N-1}$) is determined from equation (18) or (19) and equation (8). The vapor volume fraction for the upstream node is determined from equation (14) as a function of the quality and vapor density where the vapor density is determined from an input table as a function of pressure and temperature. The node friction pressure drop is then determined as a function of entering flow conditions from the equations given in paragraph 2.2.1, Attachment 1.

Since the energy balance and pressure gradient across each node is a function of the node pressure and density, an iterative solution is used to determine the pressure and density. For the first assumption, the node density and pressure are set equal to the upstream node values. The saturated values of temperature, liquid internal energy, and vapor enthalpy are determined from input thermodynamic tables at the assumed node pressure. The saturated liquid enthalpy is determined from

3.0 (Continued)

equation (32) and the node exit velocity is determined from equation (3) for the assumed flow rate and node density. The node exit enthalpy is then determined from equation (33).

The node quality and temperature are determined as a function of the node exit enthalpy at the assumed pressure. The quality is determined from equation (36), (37) or (38). If the node exit enthalpy is between the saturated liquid and vapor values, the node temperature is equal to the saturation value at the assumed pressure. If the node is superheated or subcooled, the temperature is determined from equation (35). The vapor density is determined from an input table as a function of temperature at the assumed pressure, and the node density is determined from equation (30). If the assumed density is not within 5 percent of this calculated value, a new value is assumed and the above node velocity and energy calculations are repeated. If the assumed and calculated densities converge, the velocity is corrected to the last calculated density, and the pressure change across the constant area node is determined from equation (34). The node exit pressure is then determined from,

$$P_N = P_{N-1} + (P_N - P'_{N-1}) + (P'_{N-1} - P_{N-1})$$

If the calculated node pressure is not within 0.01 psi of the assumed value, a new pressure is assumed and the above energy/momentum balance is repeated. After the "DO LOOP" is completed through the system exit node, the calculated system exit node pressure is compared to the known exit pressure. If the calculated system exit pressure is not within 0.01 psi of the known system exit pressure a new flow rate is assumed. The above pump velocity calculation and "DO LOOP" is repeated for the entire system with new flow rate assumptions until the calculated system exit pressure converges with the known value.

After the system flow rate is determined for the known system entrance and exit pressures, the two-phase choked flow relation derived in paragraph 4.2, Attachment 1, is used to determine the choked flow rate for each node. If the previously calculated flow rate exceeds the choked flow rate for any node, the node "NC" with the highest positive value of $(\dot{M} - \dot{M}^*)$ is identified. The system flow rate and pressures are then adjusted according to the procedure outlined in Figure 8. For the selected example problem, choked flow was not encountered. Therefore, the choked flow portion of the program has not been checked out.

After the steady state flow rate is determined, an iterative procedure is used to determine the corresponding pump RPM at the known pump discharge pressure. This RPM is a required input for the transient program to determine the initial flow rate. The first assumption for RPM must be input to the steady state program. For each assumed RPM, the pump flow rate, \dot{M}_C , is computed from the input pump performance table (equation(26) and equation (27)). If the computed pump flow rate is not

D180-19190-1

3.0 (Continued)

within 0.01 LBS/SEC of the system flow rate, a new RPM value is assumed and the pump flow rate calculation is repeated. After the pump RPM corresponding to the steady state system flow rate is determined the steady state program calculations are terminated.

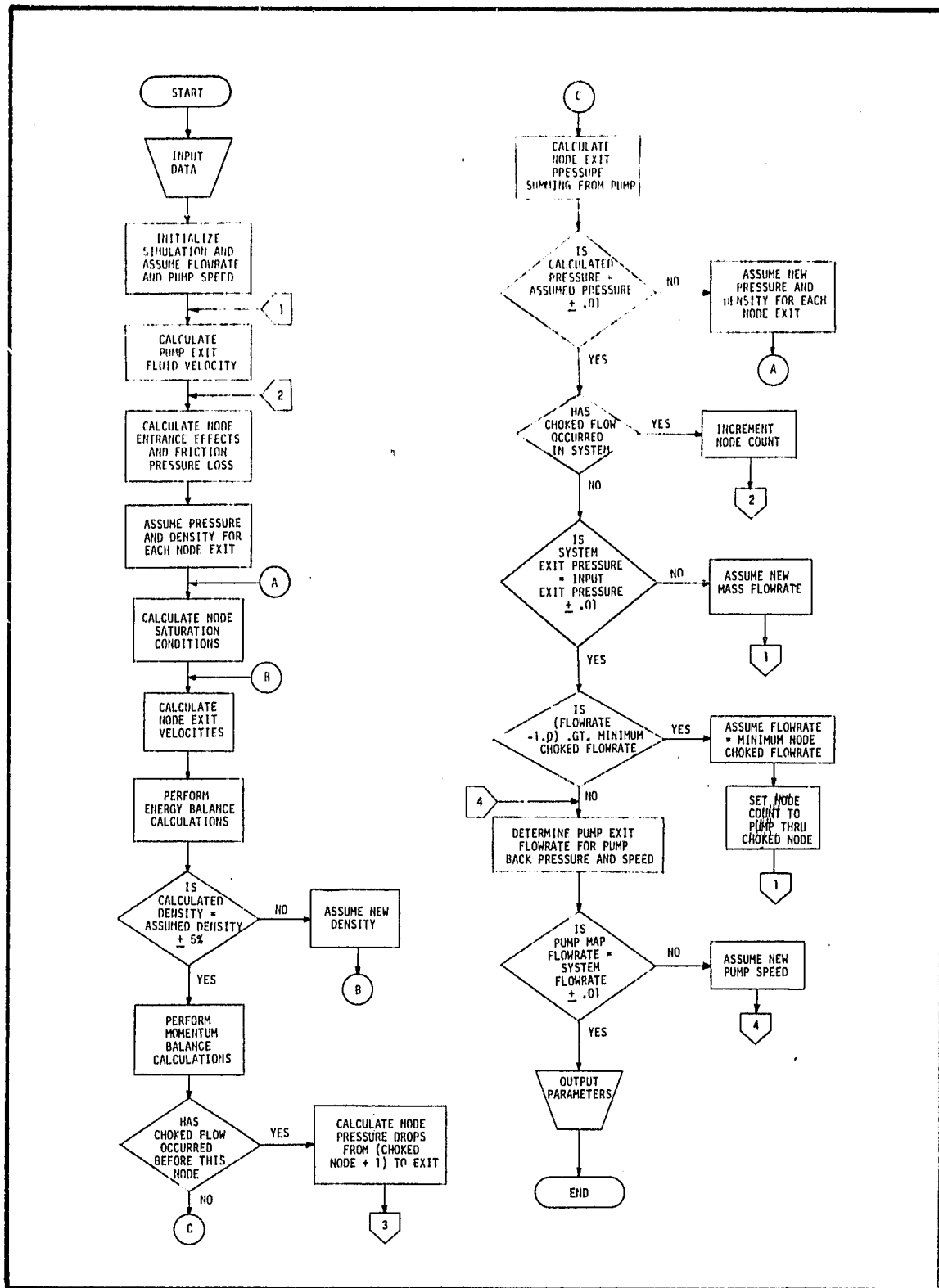

ORIGINAL PAGE IS OF POOR QUALITY

FIGURE 8 STEADY STATE CRYOGEN TRANSFER PROGRAM LOGIC

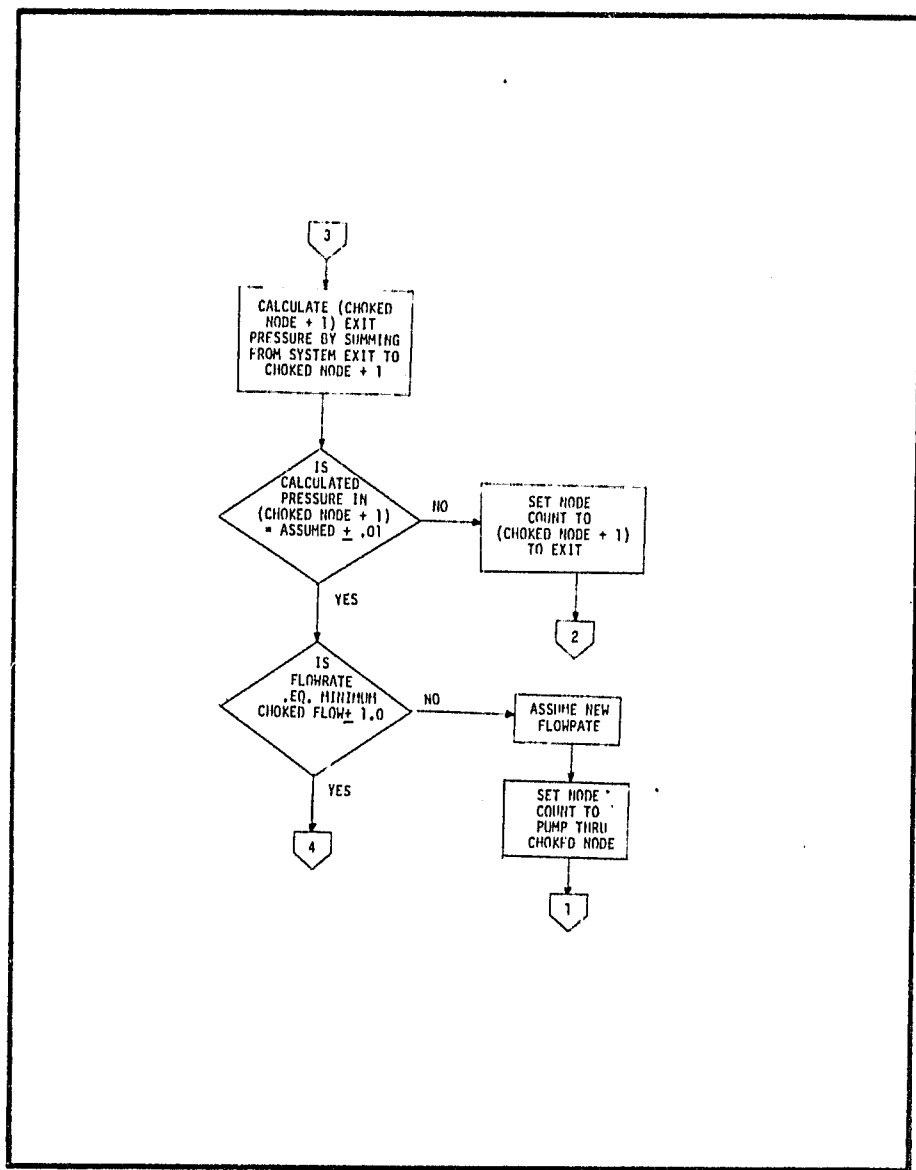

FIGURE 8 STEADY STATE CRYOGEN TRANSFER PROGRAM LOGIC (Continued)

STEADY STATE CRYOGEN TRANSFER SYSTEM ANALYSIS

4.0 INPUT DATA

The Steady State Cryogen Transfer Program (SSCTP) requires two sets of card input data. The first data set is in NAMELIST format and the second set is fixed format input. SSCTP requires no tape or disk allocations.

4.1 NAMELIST INPUT DATA

The first data set required for SSCTP input is NAMELIST WALCØN. WALCØN contains data which is punched out for use in the TCTP. The variables contained in NAMELIST WALCØN are:

- WALLM(N) - node wall mass (LB(MASS))
- WALLH(N) - node wall specific heat (BTU/LB(MASS)°R)
- MDF(N) - mass flowrate out of node N (LB(MASS)/SEC)
- P(N) - pressure at exit of node N (PSIA)
- X(N) - bulk quality in node N
- XP(N) - local quality in node N
- T(N) - temperature in node N (°R)

4.2 FIXED FORMAT INPUT DATA

The fixed format input data are given in three logical sections and set up in the following order.

- Section 1 - System Constants
- Section 2 - Nodal Data
- Section 3 - Tables

Unless otherwise noted, all values are floating point values and may be key-punched anywhere in the indicated card field (columns). Integer values must be right adjusted in their fields. A blank field (no punches in the field) is equivalent to a zero (integer or floating point).

D180-19190-1

4.2.1 System Constants

<u>CARD</u>	<u>COLUMNS</u>	<u>CONTENTS</u>
1	1-70	title to be used as print title
2	1-10	print option (Integer) = 0 do not print optional data = 1 print optional data
3	1-10	Pamb - ambient pressure (PSIA)
	11-20	g - system acceleration (FT/SEC ²)
	21-30	ρ_L - liquid density (LB(MASS)/FT ³)
	31-40	μ_V - vapor viscosity (LB(MASS)/FT-HR)
	41-50	μ_L - liquid viscosity (LB(MASS)/FT-HR)
4	1-10	β_L - liquid bulk modulus (PSI)
	11-20	C _{PL} - liquid specific heat BTU/LB(MASS)°R
	21-30	C _{PV} - vapor specific heat at constant pressure (BTU/LB(MASS)°R)
	31-40	C _{VV} - vapor specific heat at constant volume (BTU/LB(MASS)°R)
5	1-10	T ₁ - pump outlet temperature (°R)
	11-21	P _{KI} - exit node pressure (PSIA)
	21-30	\dot{M} - assumed system flow rate
	31-40	P(1) - pump discharge pressure (PSIA)
	41-50	RPM - Pump RPM Assumption (RPM)
6	1-10	N _p - pump external node number (integer)
	11-20	N _T - transfer line low and high
	21-30	external node numbers (integer)
	31-40	N _V - vent line low and high
	41-50	external node numbers (integer)

4.2.1 (Continued)

<u>CARD</u>	<u>COLUMNS</u>	<u>CONTENTS</u>
	51-60	N_F - fill line low and high
	61-70	external node numbers (integer)
7	1-10 11-20 21-30 31-40 41-50 51-60 61-70	(N_P) - external node numbers (integer) of the nodes for which print is desired. One to seven node numbers per card (zero node numbers are ignored). Repeat the card until all nodes are given. To print all nodes, omit this card(s).
8	1-70	Blank - a blank card to signal the end of print nodes input.

4.2.2 Section 2 - Nodal Data

<u>CARD</u>	<u>COLUMNS</u>	<u>CONTENTS</u>
1	1-10 11-20 21-30 31-40 41-50 51-60 61-70	N_N - external node number D_N - diameter (FT) L_N - length (FT) Z_N - elevation (FT) q_{EXT} - external heat flux (BTU/FT ² SEC) K_{AN} - loss coefficient for area change Option Constant (integer) = 0 use V_{N-1} to calculate friction pressure loss = 1 use V_{N-1}
2	11-20	$\Sigma(L/D)$ for node (actual length/diameter + component (L/D)e)
3	1-70	Blank - a blank card to signal the end of nodal data.

4.2.2 (Continued)

Card 1 is repeated for each node. Card 2 follows the definition of the last node.

The nodes do not have to be given in any particular order. The program will sort them by line section and node number and assign internal node sequencing.

No external node number may be zero or negative.

4.2.3 Section 3 - Tables

Table #1	Vapor density as a function of pressure and temperature $\rho v = f_1 (P, T)$
Table #2	Saturation temperature as a function of pressure $T_S = f_2 (P)$
Table #3	Liquid saturated internal energy as a function of temperature (Table #4 in transient program) $U_{LS} = f_3 (T)$
Table #4	Friction factor correction as a function of vapor volume (Table #5, transient program) $(f_{TP}/f_0) = f_4 (1 - \alpha)$
Table #5	Single phase friction factor as a function of Reynolds number (Table #6 in transient program) $(f_0) = f_5 \left(\frac{\rho v D}{\mu} \right)$
Table #7	(Pump flow rate/RPM) as a function of (Pressure/RPM ²) (Table #9 in transient program) $\left(\frac{\dot{M}}{RPM} \right) = f_7 \left(\frac{P - P_{amb}}{RPM^2} \right)$

4.2.3 (Continued)

Table #8 Saturation vapor enthalpy as a function of temperature
(Table #12 in transient program)

$$h_{VS} = f_g(T)$$

The table input cards have the following columns and content.

<u>CARD</u>	<u>COLUMN</u>	<u>CONTENTS</u>
3.1	1-10	N_T - table number (integer)
	11-20	NT_{β} - Built in table type (integer) - Tables #1, #2, #3 and #8 have been built into the program for various types of fluid. Tables #4 and #5 have been built in also. When a built in table is to be used, NT_{β} is a number defining the type of fluid (Tables #1, #2, #3, and #8). $NT_{\beta} = 1$ - LOX $NT_{\beta} = 2$ - LH ₂ (a future addition) For Tables #4 and #5 $NT_{\beta} = 1$
	21-30	N_N - Used for input of Table #6 and is the node number for this Table #6 (integer)
	31-40	N'_N - (Used for Table #6 only. Table #6 for node N'_N (see columns 21-30 above) is identical to Table #6 for node N_N .)
	41-50	X values scale factor
	51-60	Y values scale factor
	61-70	Z values scale factor

NOTE: Set $NT_{\beta} = 0$ to read the value from cards.

NOTE: Right adjust exponential scale factor.

When the table is given on cards, it may be convenient to scale the values. For two dimensional tables, the X scale factor scales the independent variables. For three dimensional tables, the X and Y scale factors scale the independent variables, and the Z scale factor the dependent variable. In all cases the scaling is (desired value) = (scale factor) times (input value).

NOTE: For Tables #1 - #5 and #8, when NT_{β} is given, and for Table #6 when N'_N is given (non-zero), Card 3.1 is all that is required as input.

4.2.3 (Continued)

<u>CARD</u>	<u>COLUMNS</u>	<u>CONTENTS</u>
3.2	--	For two dimensional tables only (Tables #2, #3, #4, #5, #6 (all nodes), #7 and #8)
	11-20	X_1 - the independent value
	21-30	Y_1 - the dependent values at X_1
	31-40	X_2
	41-50	Y_2
	51-60	X_3
	61-70	Y_3

NOTE: The values are given in pairs. If the card columns for any pair are left blank, or both values are zero, then the pair is discarded. To obtain a true zero-zero pair, input one value very small (i.e. 1.0 E -6.0). At least one pair must be given on each card.

3.3 to 3.K-1		- Repeat card 3.2 as necessary to input the complete table.
3.K		- One blank card to signal the end of the table.
3.2	--	For three dimensional tables only (Table #1)
	11-20	X_1 - first independent value
	21-30	Y_1 - second independent value
	31-40	Z_1 - dependent value at X_1, Y_1
	41-50	Y_2
	51-60	Y_2
	61-70	Z_2

NOTE: The values are given in sets of three. If the card columns for any set are zero, the set is discarded. To obtain a true zero-zero-zero-set, input one value very small (1.0E-6.0). At least one set must be given on each card.

4.2.3 (Continued)

<u>CARD</u>	<u>COLUMNS</u>	<u>CONTENTS</u>
3.3 to 3.K-1		- Repeat card 3.2 as necessary to input complete table.
3.K		- One blank card to signal the end of the table.

Card 3.1 must be given for each table. If not given for Tables #1, #2, #3, #4, #5, or #8, the built-in table(s) will be used. To default to a fluid other than LOX, use a card 3.1 with the table number = 0, and the type of fluid (NT_{β}) set for the fluid desired. Table #6 is not needed for all nodes. For the nodes for which a table #6 is not given, a value of $Ke = 0.0$ will be used.

Cards 3.2 to 3.K must be given for each table unless the value of NT_{β} (tables #1 to #5 and #8) or the value of N_N (table #6 only) indicate otherwise, in which case cards 3.2 to 3.K must be omitted.

Card 3.K is required for all tables when the values are given as input (card 3.2 etc.).

Tables may be input in any order.

4.2.4 Deck Sequencing

Card columns 71 to 80 are not used by the program, and therefore can be used for deck sequencing. A suggested method of sequencing is as follows:

<u>COLUMNS</u>	<u>VALUE</u>
72	Section number
73-74	Table number (Section 3.0 only)
75-78	Node number (Section 2.0 and Section 3.0 tables #6 only)
79-80	Card number

1.0 CRYOGEN TRANSFER NOMENCLATURE

SYMBOL	DEFINITION	UNITS
A	Area	Ft^2
C	Specific Heat	$\text{BTU}/\text{LB}_M^{\circ}\text{P}$
D	Diameter	Ft
Eu	Euler Number	Dimensionless
F	Force	LB_F
f_0	Single Phase Friction Factor Evaluated at the Mixture Reynolds Number	Dimensionless
f_{TP}	Two - Phase Friction Factor	Dimensionless
g	Gravitational Acceleration or Orbital Transfer System Acceleration	Ft/Sec^2
g_C	Constant of Proportionality	$\frac{\text{LB}_M\text{-FT}}{\text{LB}_F\text{-SEC}^2}$
h	Node Bulk Enthalpy	BTU/LB_M
h'	Average Enthalpy at a Node Exit	BTU/LB_M
h_C	Heat Transfer Film Coefficient	$\text{BTU}/\text{FT}^2\text{-HR-}^{\circ}\text{R}$
J	Conversion Factor	$\frac{\text{FT-LB}_F}{\text{BTU}}$
K	Friction Loss Factor	Dimensionless
k	Thermal Conductivity	$\frac{\text{BTU}}{\text{FT-HR-}^{\circ}\text{R}}$
l	Line Segment(or node) length	FT
M	Mass in the Control Volume or Node	LB_M
\dot{M}	Mass Flow Rate	LB_M/SEC
N	Pump Speed	RPM
N_U	Nusselt Number	Dimensionless

D180-19190-1

1.0 (Continued)

SYMBOL	DEFINITION	UNITS
P	Static Pressure	PSIA
P'	Static Pressure Downstream of an Area Change	PSIA
P _R	Prandtle Number	Dimensionless
q	Heat Transfer Rate (BTU/FT ² -SEC in computer program)	BTU/SEC
T	Temperature	°R
t	Time	SEC
U	Internal Energy	BTU/LB _M
V	Volume	FT ³
v	Velocity	FT/SEC
X	Node Bulk Quality	Dimensionless
X'	Average Quality at a Node Exit	Dimensionless
Z	Elevation at a Node Exit	FT
α	Node Bulk Vapor Volume Fraction	Dimensionless
α'	Average Vapor Volume Fraction at a Node Exit	Dimensionless
μ	Viscosity	LB _M /FT-SEC
ρ	Node Bulk Density	LB _M /FT ³
ρ'	Average Density at a Node Exit	LB _M /FT ³
Ψ _{TT}	Martinelli Two Phase Parameter	Dimensionless

SUBSCRIPTS DEFINITION

I	Pump Discharge
A	Area Change
C	Calculated
EXP	Experimental
E	Equivalent Value

D180-19190-1

1.0 (Continued)

SUBSCRIPTS	DEFINITION
F	Friction or Final Value
I	Initial Value
IN	Inlet
L	Liquid
N	Node Number
O	Single Phase Value
S	Saturated
TP	Two-Phase Value
V	Vapor
W	Wall

2.0 REFERENCES

1. A. H. Shapiro, The Dynamics and Thermodynamics of Compressible Fluid Flow, Volume I, 1953.
2. R. W. Graham, R. C. Hendricks and R. J. Simoneau, NASA Lewis Research Center, "A Survey of Heat Transfer to Low-Temperature Fluids," Space Institute, University of Tennessee, January 1970.
3. R. C. Hendricks, R. W. Graham, Y. Y. Hsu, and R. Friedman, "Experimental Heat Transfer and Pressure Drop of Liquid Hydrogen Flowing Through a Heated Tube," NASA TN D-765, May 1961.
4. R. C. Hendricks, R. W. Graham, Y. Y. Hsu, and R. Friedman, "Experimental Heat Transfer Results for Cryogenic Hydrogen Flowing in Tubes at Subcritical and Supercritical Pressures to 800 Pounds Per Square Inch Absolute," NASA TN D-3095, 1966.
5. S. Ranatza and W. J. Phares, "Two-Phase (gas-liquid) Flow Analysis," Boeing Document, D5-12218, November 1966.
6. A. E. Dukler, M. Wicks III, and R. G. Cleveland, "Frictional Pressure Drop in Two Phase Flow: B. An Approach Through Similarity Analysis," AIChE Journal, Vol. 10, No. 1, p.p. 45-51, January 1964.
7. Dr. W. Frost, "Two-Phase Flow Through Abrupt Expansions and Contractions," Two-Phase Flow and Low Temperature Heat Transfer Short Course, University of Tennessee Space Institute, January 1970.
8. R. L. Daugherty and A. C. Ingersoll, Fluid Mechanics with Engineering Applications, 1954
9. Boeing Memorandum 5-9030-HT-116, B. L. Osborne to T. W. Winstead, "Submittal of Monthly Progress Report Number 1", dated June 10, 1974.
10. Boeing Letter Report 2-1056-HT-082, "National Space and Technology Laboratories (NSTL) LOX Loading Facility Analyses," dated May 8, 1975.
11. Boeing Letter Report 2-1056-HT-165, "TCTP Application to the SSME Hydrogen System Analysis," dated December 1, 1975.

D180-19190-1

2.0 (Continued)

12. NBS Technical Note 617, "Thermophysical Properties of Parahydrogen from the Freezing Liquid Line to 5000 R for Pressures to 10,000 Psia", dated April 1972.
13. NASA SP-3071, "ASRDI Oxygen Technology Survey, Volume I: Thermophysical Properties", 1972.

D180-19190-1

APPENDIX B

TRANSIENT CRYOGEN TRANSFER PROGRAM
VERIFICATION PRESENTATION

The presentation in this Appendix gives the results of additional program verification analyses which were made due to program updates since the program development reported in Letter Report 5-9030-HT-158, "Cryogen Transfer Computer Program Development and Verification," dated September 3, 1974.

TRANSIENT

CRYOGEN*

TRANSFER

PROGRAM

*Applicable to any boiling fluid.

B-2

D180-19190-1

BOEING AEROSPACE COMPANY
SPACE SYSTEMS DIVISION
HUNTSVILLE, ALABAMA

CRYOGEN LOADING PROBLEM STATEMENT

V. L. GLASGOW
NOVEMBER 25, 1974

2

- GIVEN
 - TYPE OF FLUID (LOX, LH₂, ETC.)
 - SYSTEM DESCRIPTION
 - PUMP PERFORMANCE OR WINDMILLING PRESSURE DROP CHARACTERISTICS
 - LINE GEOMETRY AND COMPONENTS
 - STEADY STATE HEAT LEAK
 - BOUNDARY CONDITIONS VS. TIME
 - PUMP RPM OR FLOW RATE
 - INLET CONDITIONS (PUMP INLET OR STORAGE TANK)
 - FLOW CONTROL VALVE POSITIONS
 - SYSTEM EXIT PRESSURE
- REQUIRED
 - LOCAL TRANSIENT PROPERTIES AND FLOW CONDITIONS FOR ONE OR TWO-PHASE FLOW AT ANY POINT IN THE SYSTEM
- SOLUTION
 - INTEGRATED ANALYSIS OF PUMP AND SYSTEM PERFORMANCE; FINITE ELEMENT METHOD INCORPORATING UNSTEADY ENERGY, MASS AND MOMENTUM WITH TWO-PHASE PROPERTY, FRICTION LOSS, AND HEAT TRANSFER RELATIONS

B-3

D180-19190-1

**BOEING AEROSPACE COMPANY
SPACE SYSTEMS DIVISION
HUNTSVILLE, ALABAMA**

COMPUTER PROGRAM DEVELOPMENT AND VERIFICATION

V. L. GLASGOW
NOVEMBER 25, 1974

3

- TRANSIENT CRYOGEN TRANSFER PROGRAM (TCTP) DEVELOPED FOR SHUTTLE CRYOGEN LOADING ANALYSES

- TCTP VERIFIED BY S-IB STAGE LOX LOADING SYSTEM ANALYSIS
 - TANK HEAD FLOW
 - PUMP RAMP FLOW

- VERIFICATION ANALYSIS SAMPLE RESULTS
 - TANK HEAD FLOW TRANSIENTS
 - PUMP BUILD-UP FLOW AND BACK PRESSURE TRANSIENTS
 - THERMODYNAMIC STATE AS A FUNCTION OF TIME AND LOCATION
 - FLOW RATE AS A FUNCTION OF TIME AND LOCATION
 - SYSTEM TEMPERATURE AND PRESSURES AS A FUNCTION OF TIME AND LOCATION

B-4

D180-19190-1

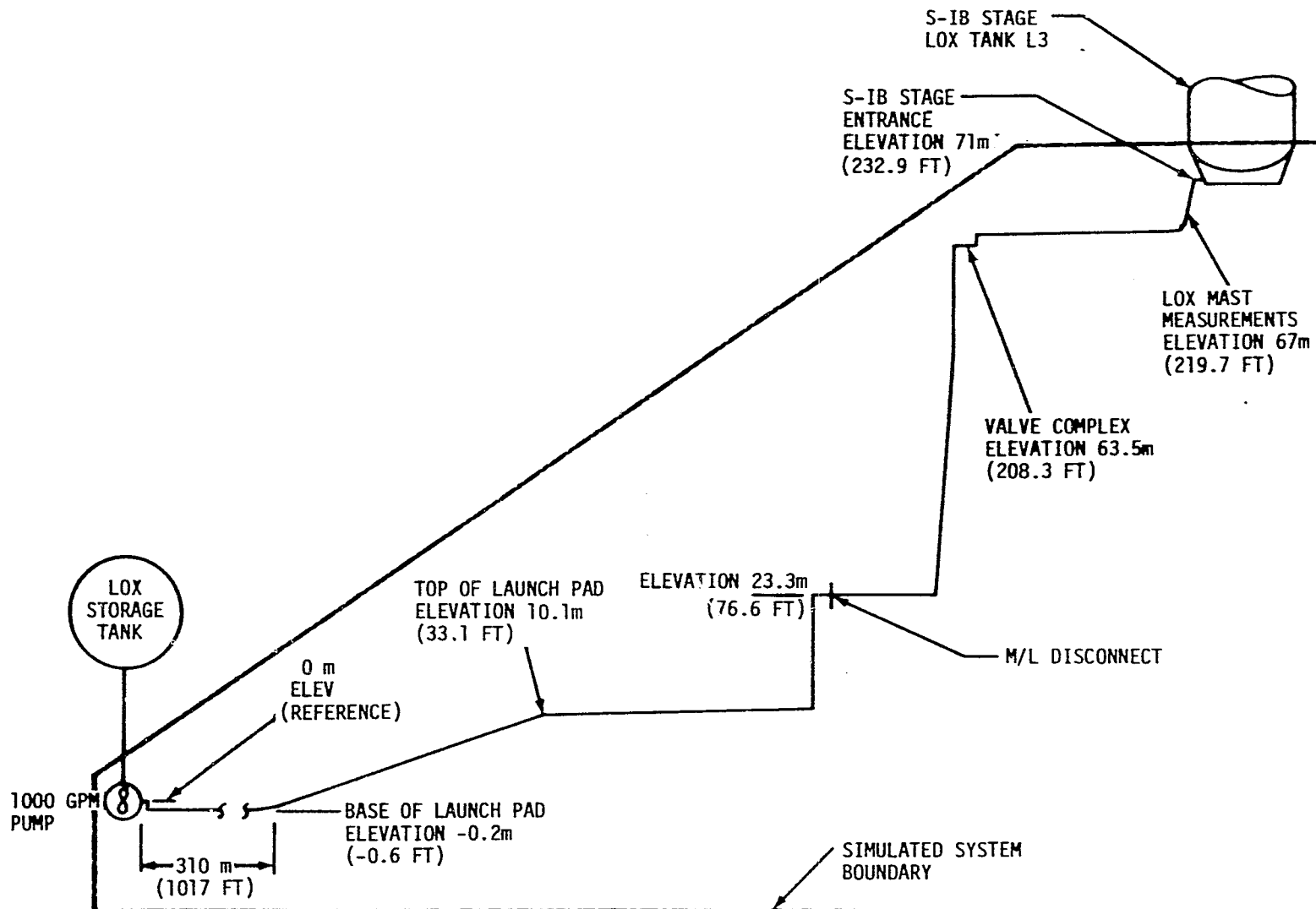

B-5

D180-19190-1

**BOEING AEROSPACE COMPANY
SPACE SYSTEMS DIVISION
HUNTSVILLE, ALABAMA**

S-IB TANK HEAD FLOW TRANSIENT

V. L. GLASGOW
NOVEMBER 25, 1974

5

- FLOW INITIALIZED BY OPENING VALVE A28750
- SYSTEM INITIAL TEMPERATURE DOWNSTREAM OF A28750: AMBIENT
- SYSTEM INITIAL PRESSURE DOWNSTREAM OF A28750: 1 PSIG
- QUALITY UPSTREAM OF A28750: 0.0
- QUALITY DOWNSTREAM OF A28750: 1.0
- INITIAL PUMP FLOW RATES: 0.0
- INITIAL SYSTEM EXIT FLOW RATE: 0.0
- AS-208 LCD DATA INPUT: PUMP INLET PRESSURE VS. TIME
PUMP DISCHARGE TEMPERATURE VS. TIME
SYSTEM EXIT PRESSURE VS. TIME

B-6

D180-19190-1

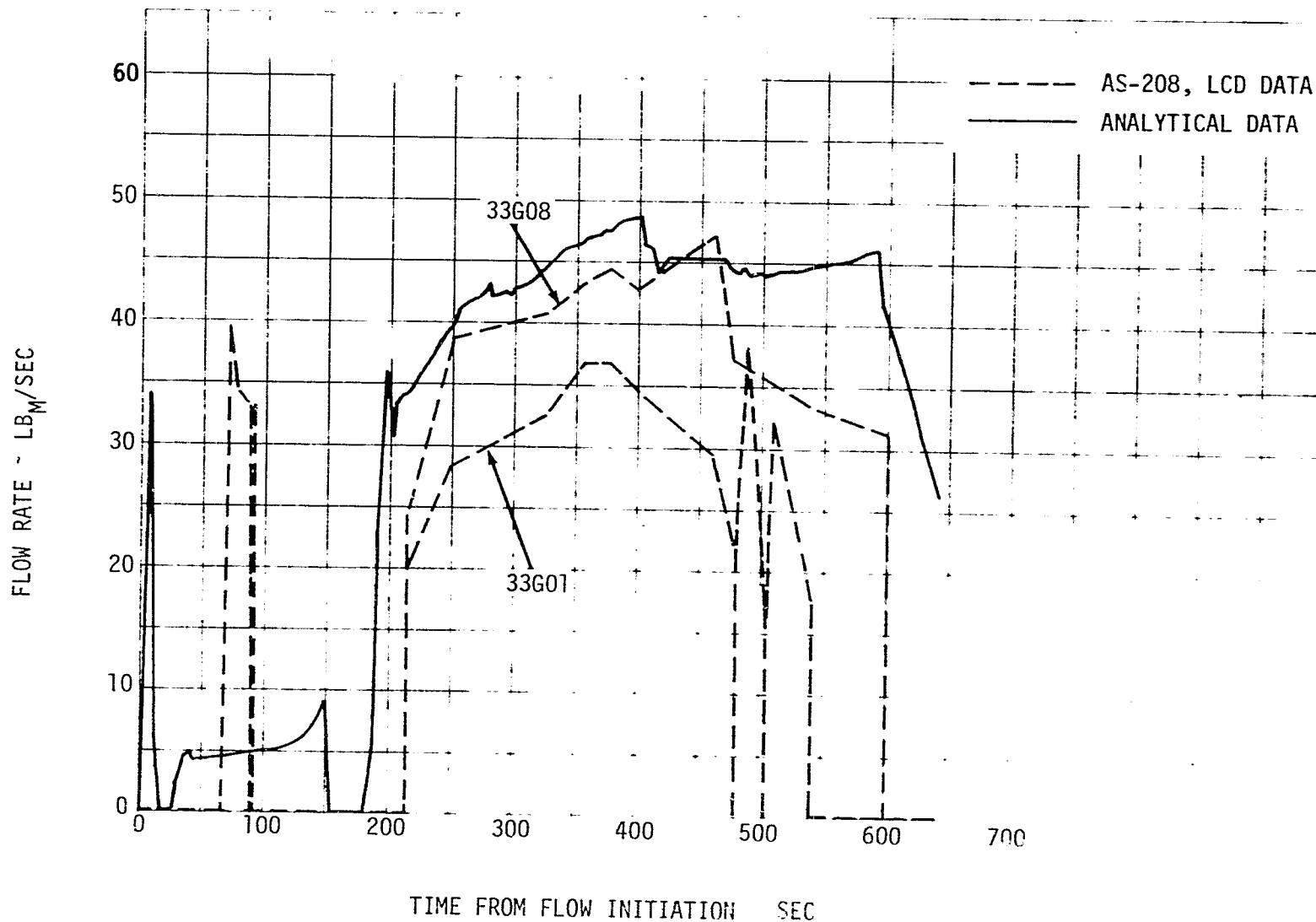

B-7

D180-19190-1

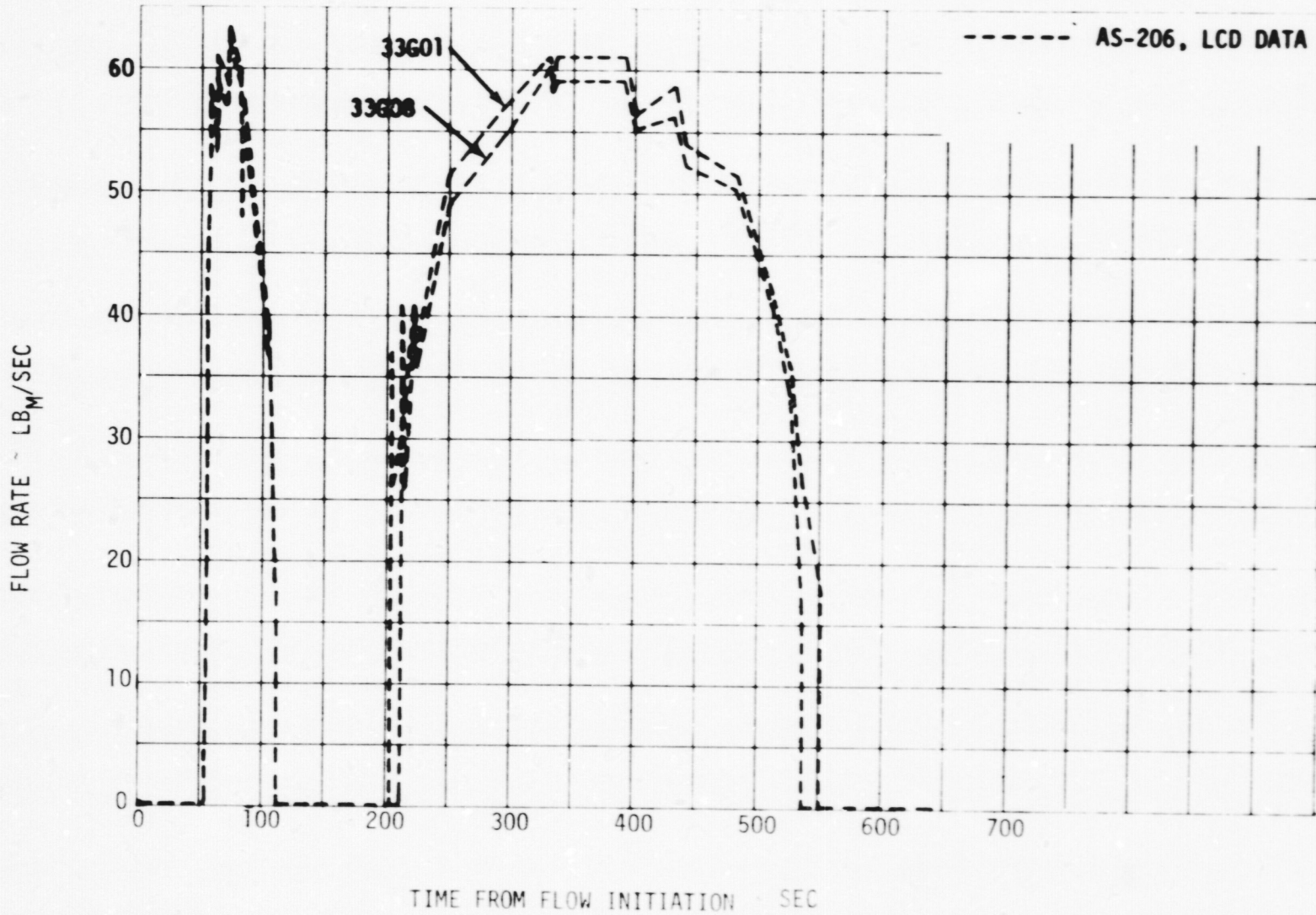

8-8

D180-19190-1

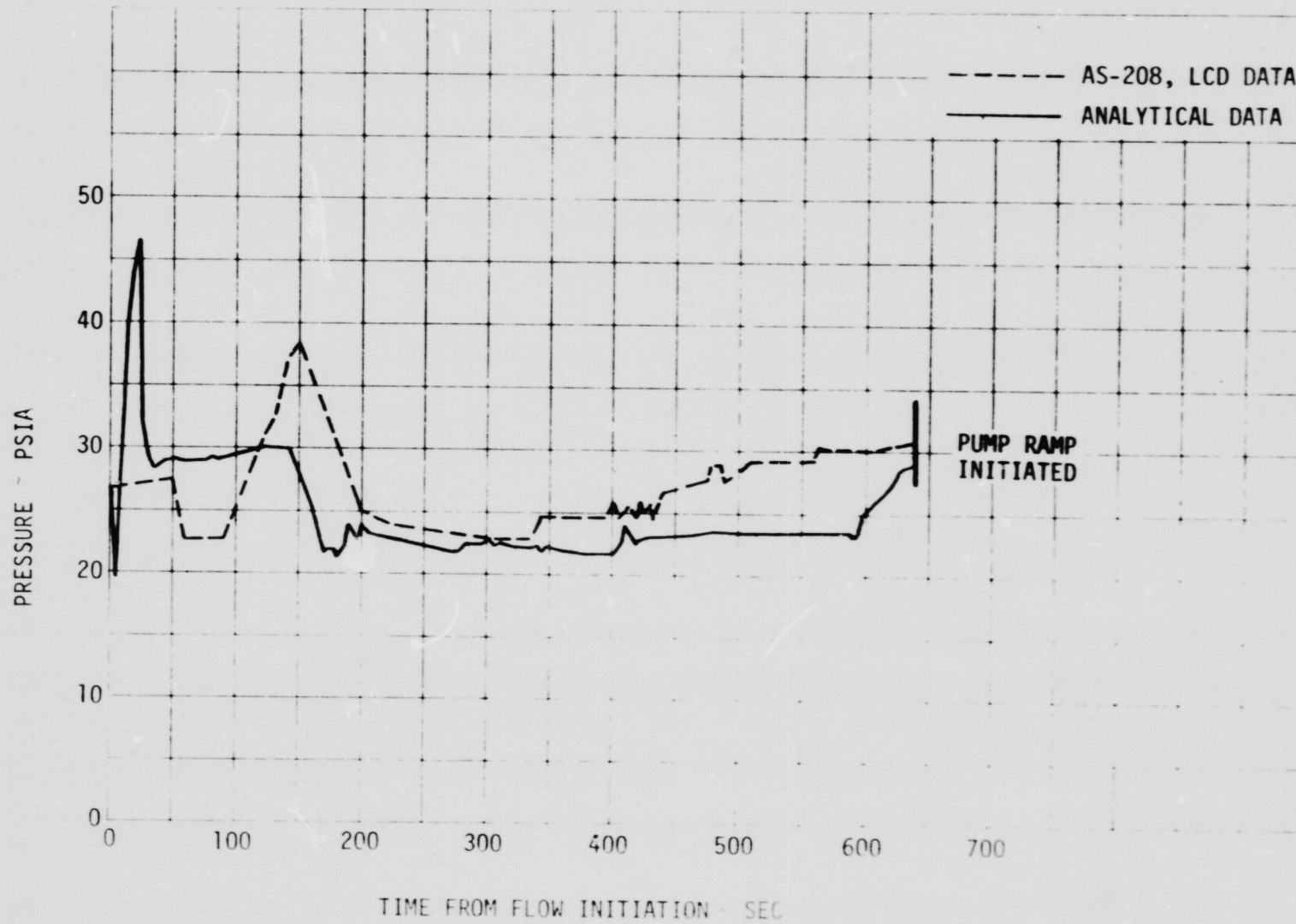

B-9

D180-19190-1

**BOEING AEROSPACE COMPANY
SPACE SYSTEMS DIVISION
HUNTSVILLE, ALABAMA**

TRANSIENT PUMP DISCHARGE PRESSURE
(TANK HEAD FLOW)

V. L. GLASGOW
NOVEMBER 25, 1974

7A

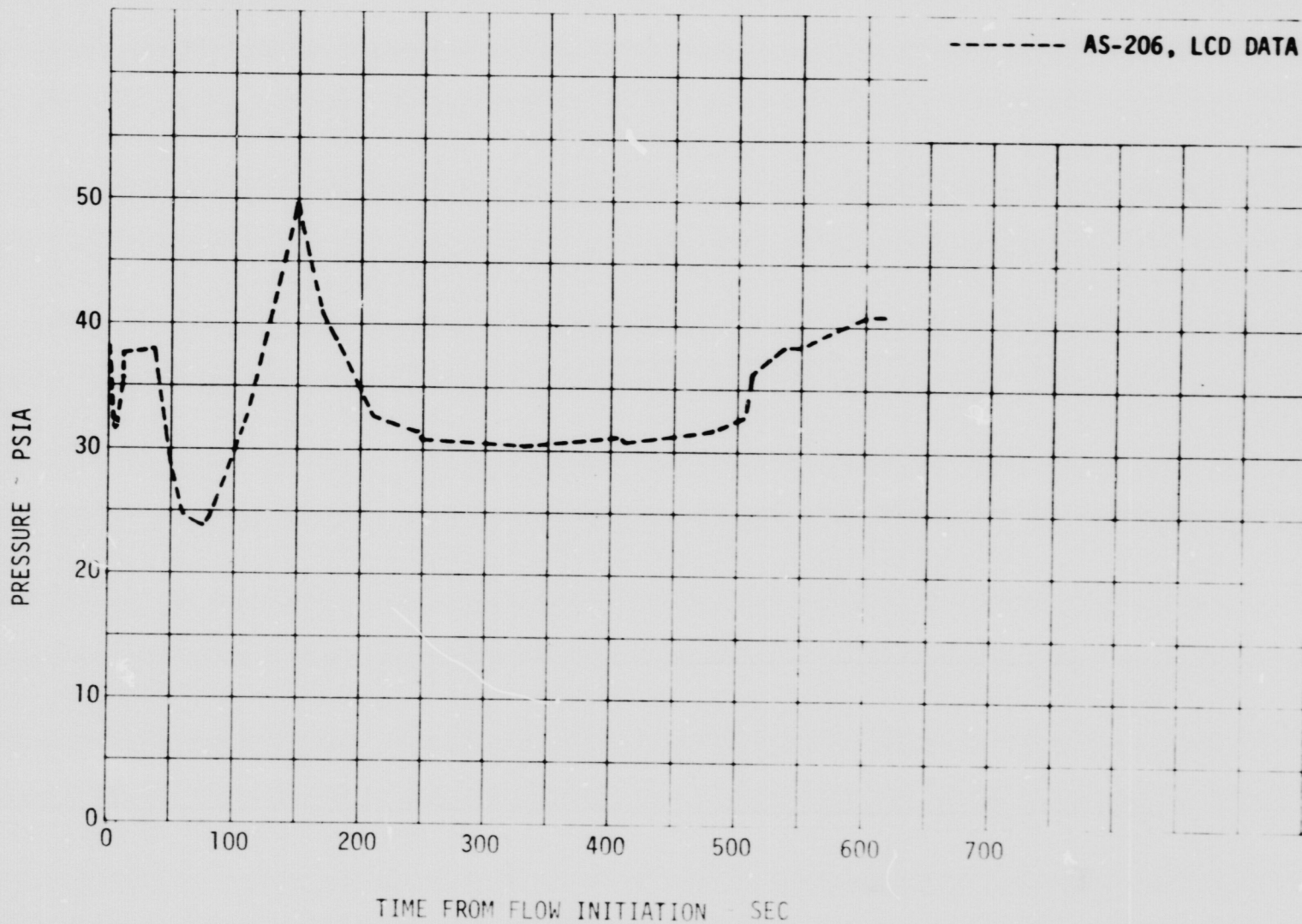

B-10

D180-19190-1

- FIRST PUMP RPM RAMP INITIATED 636 SECONDS AFTER OPENING VALVE A28750

- SYSTEM PRESSURES, TEMPERATURES, FLOW RATES, AND QUALITIES CALCULATED FROM TANK HEAD FLOW

- AS-208 LCD DATA INPUT:
 - PUMP RPM VS. TIME
 - PUMP INLET PRESSURE VS. TIME
 - PUMP DISCHARGE TEMPERATURE VS. TIME
 - SYSTEM EXIT PRESSURE VS. TIME

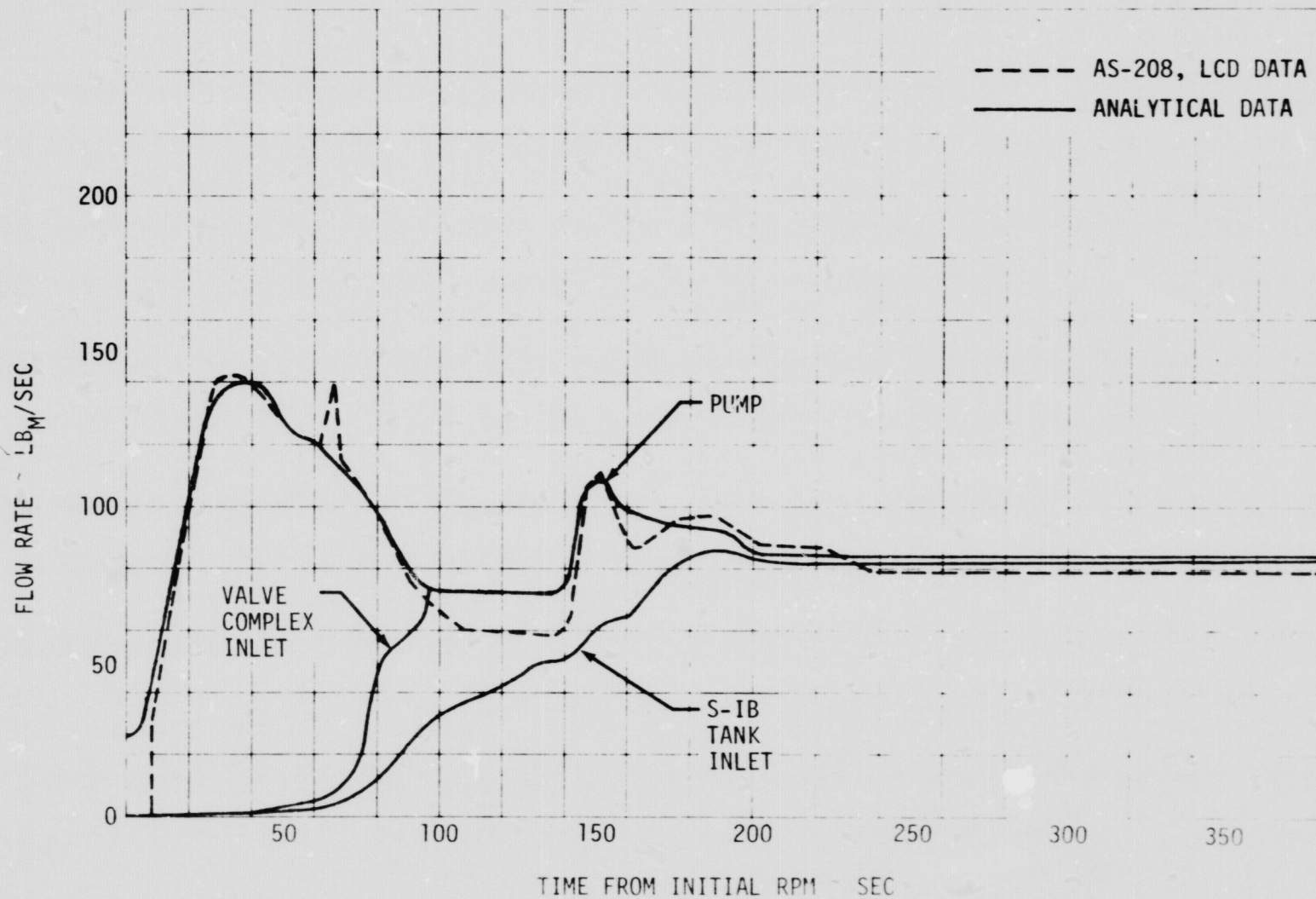

B-12

D180-19190-1

BOEING AEROSPACE COMPANY
SPACE SYSTEMS DIVISION
HUNTSVILLE, ALABAMA

TRANSIENT SYSTEM LIQUID FLOW RATES
(PUMP RAMP)

V. L. GLASGOW
NOVEMBER 25, 1974

9A

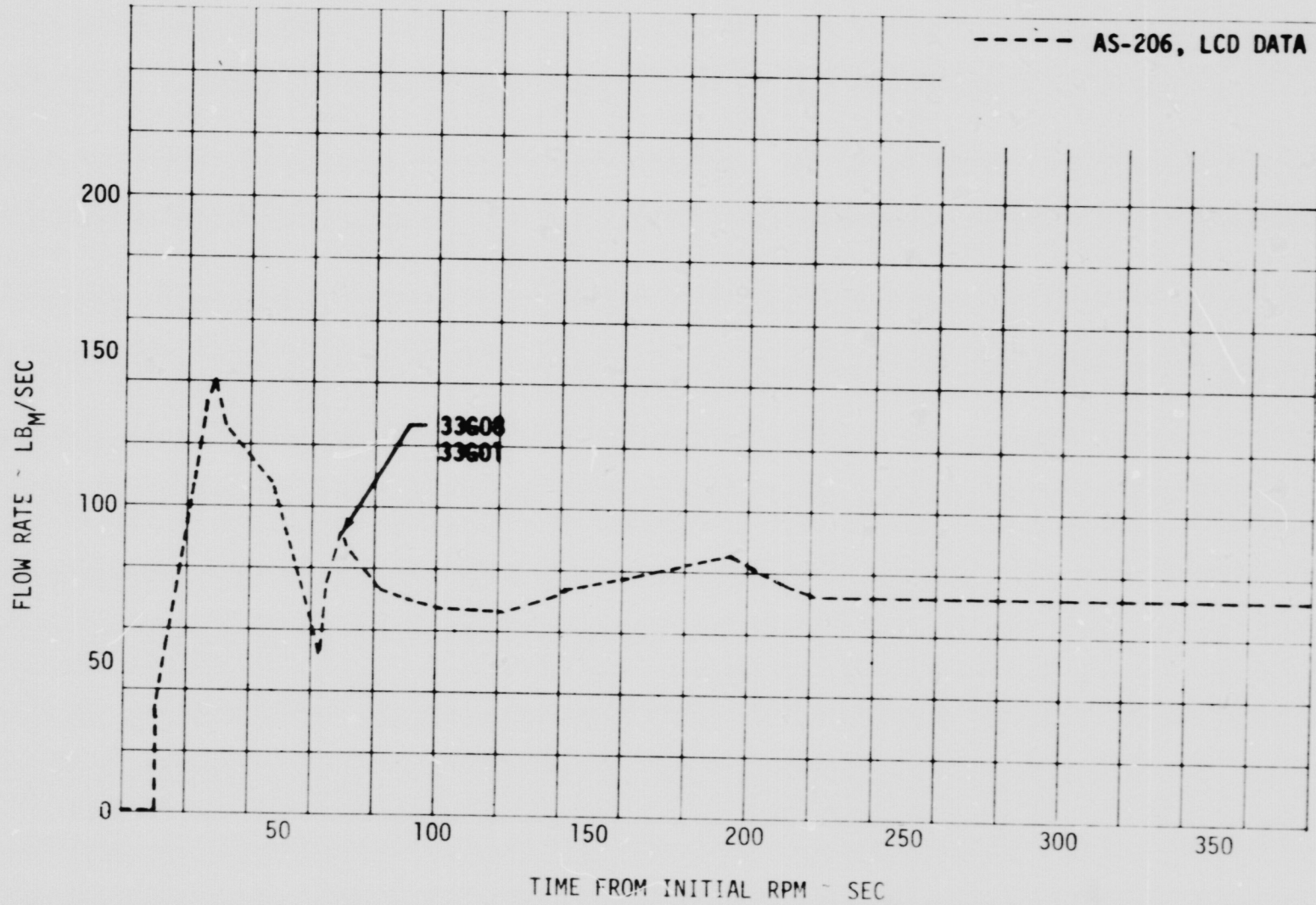

B-13

D180-19190-1

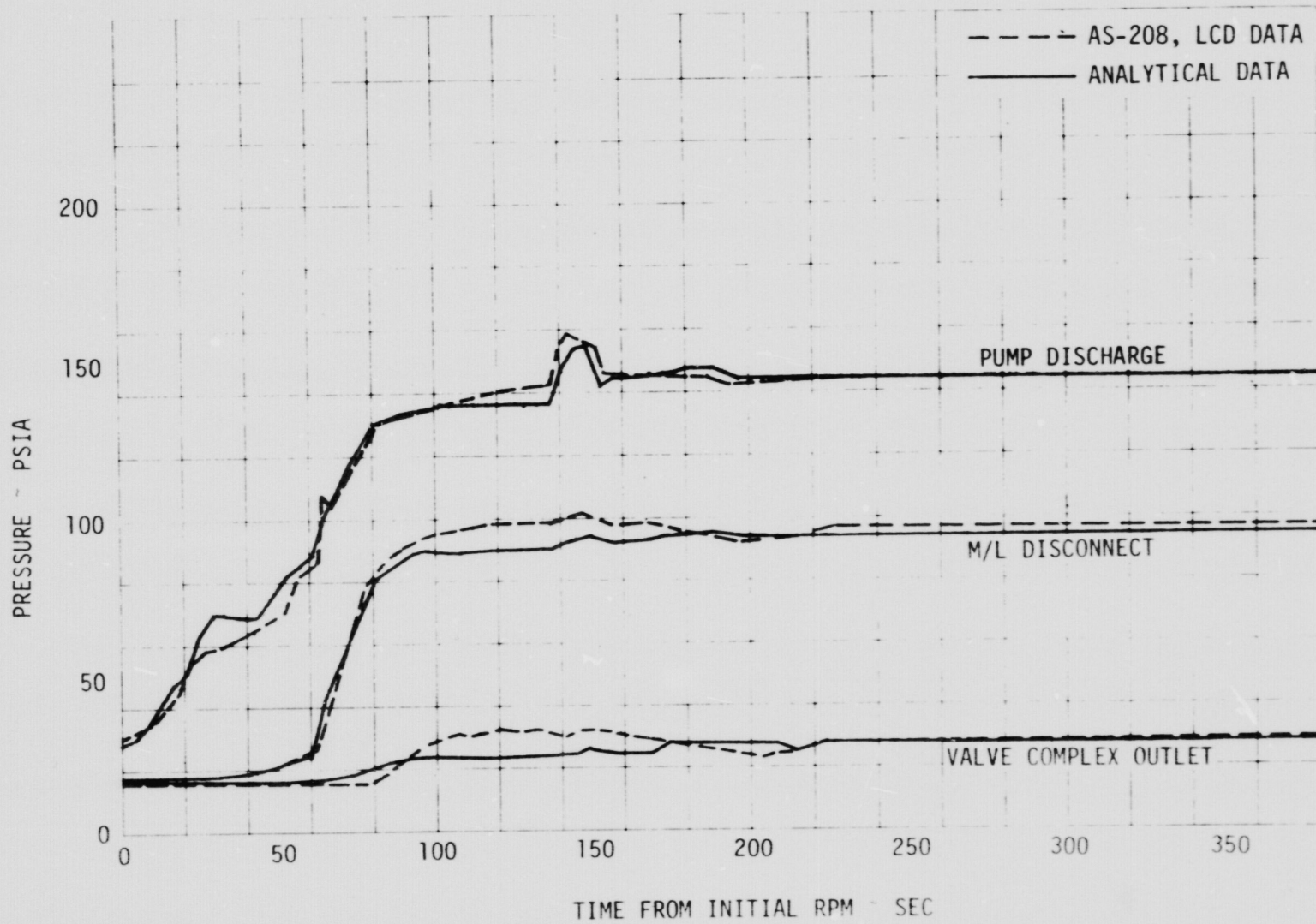

B-14

D180-19190-1

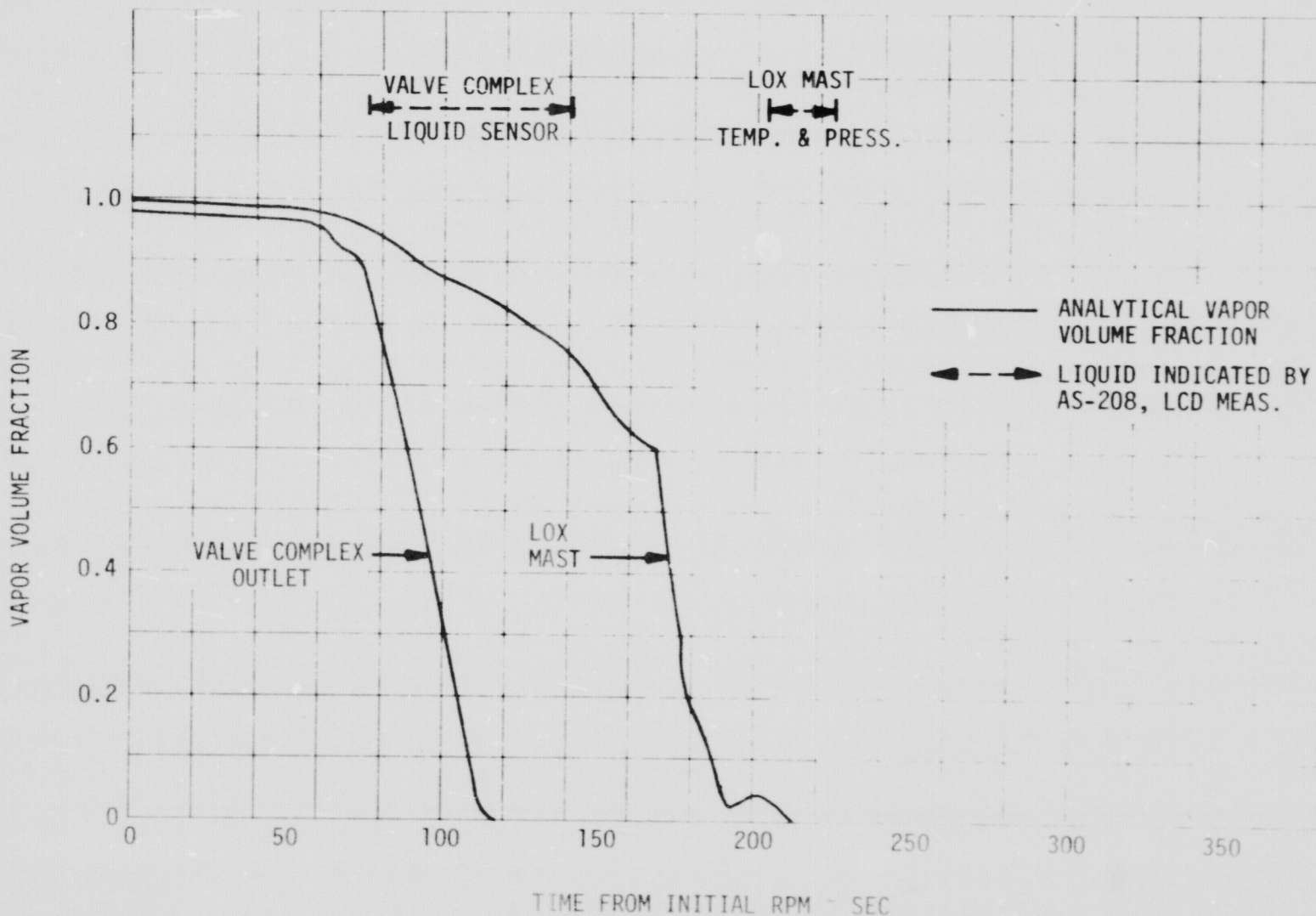

B-15

D180-19190-1

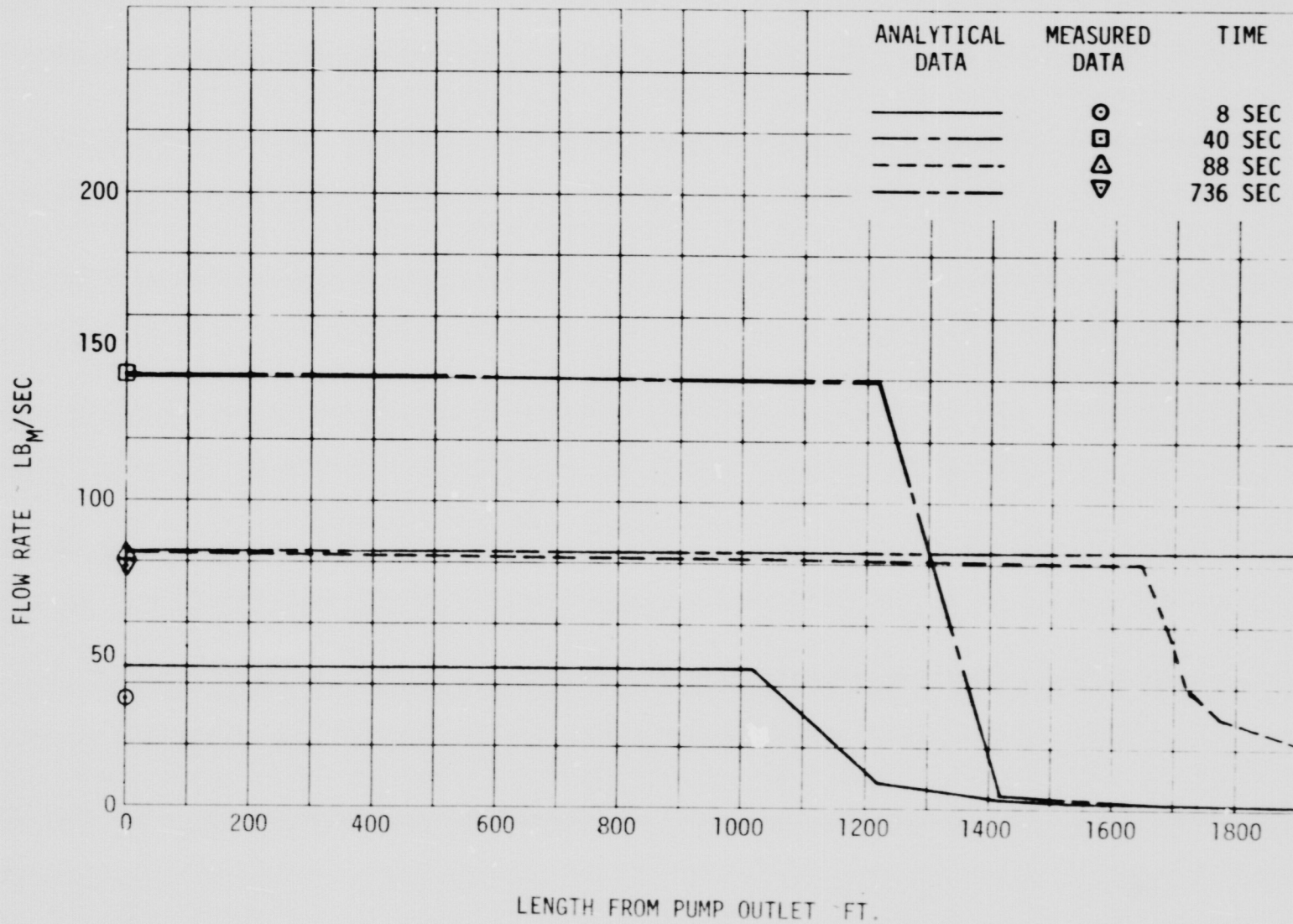

B-16

D180-19190-1

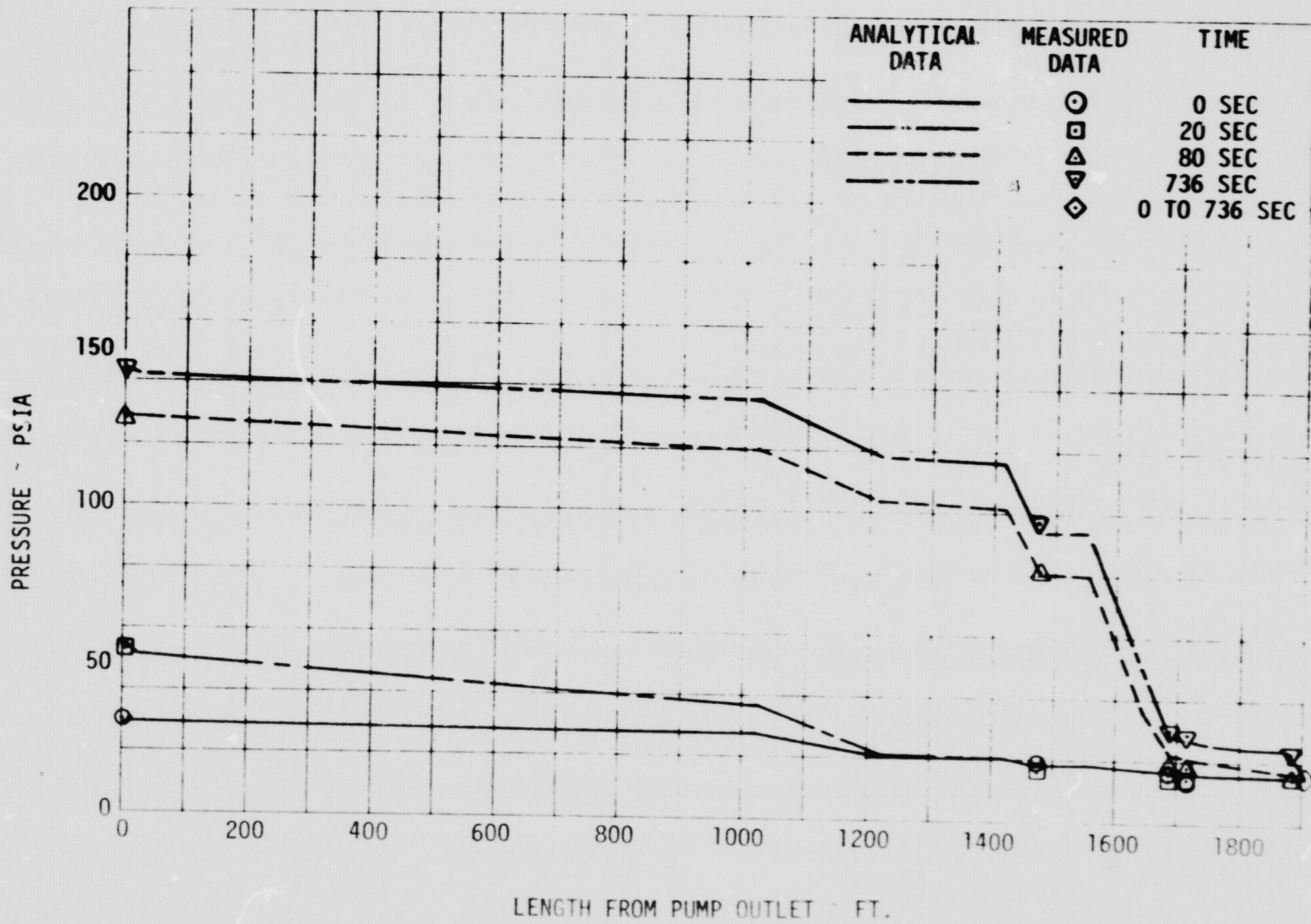

B-17

D180-19190-1

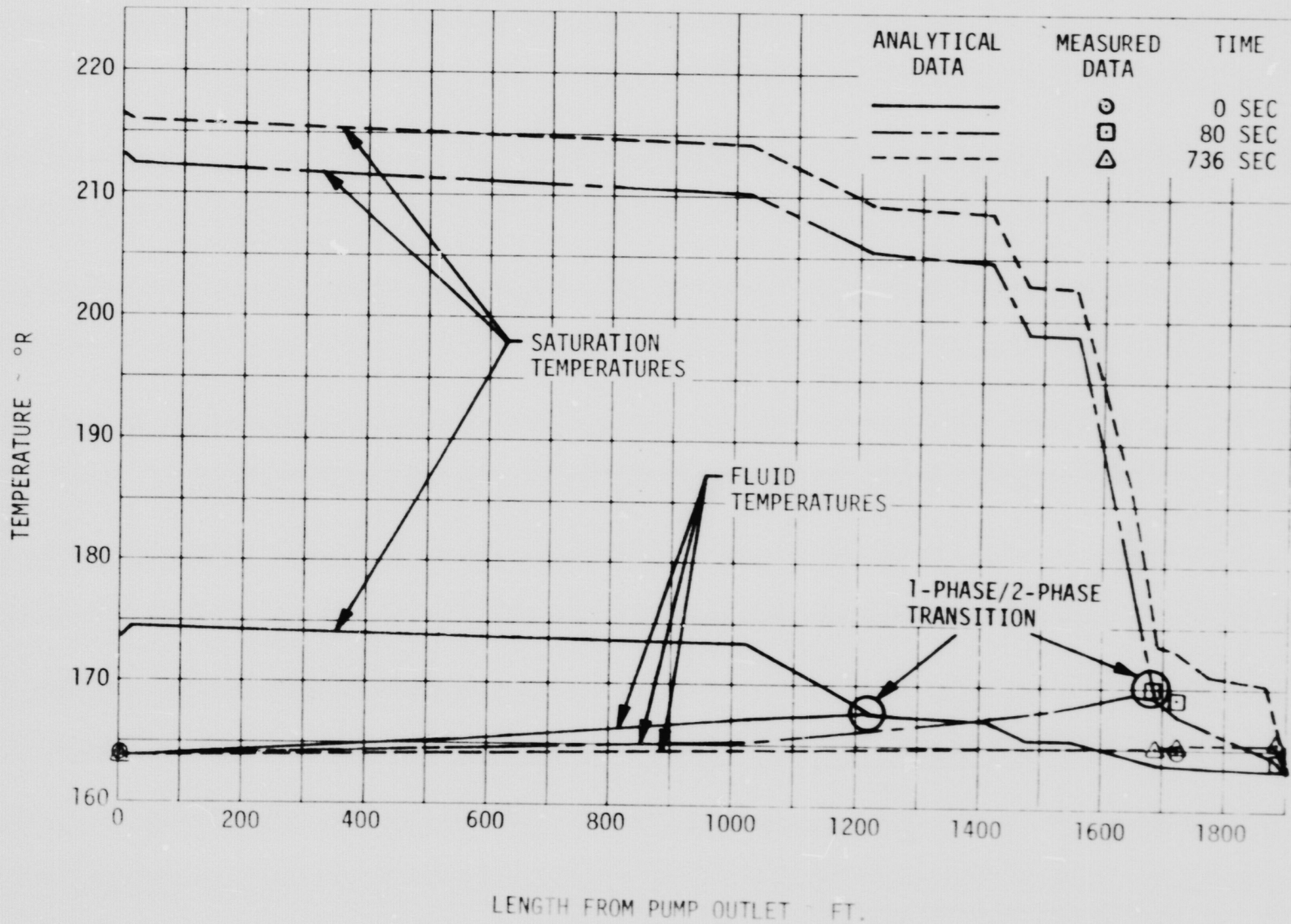

B-18

D180-19190-1

● CURRENT COMPUTER PROGRAM CAPABILITIES

- PREDICTS LOCAL TRANSIENT ONE OR TWO-PHASE PROPERTIES
- ANY FLUID FOR WHICH THERMODYNAMIC TABLES ARE PROVIDED
- VARIOUS LINE GEOMETRY, COMPONENTS AND HEAT LEAK
- TRANSIENT TANK HEAD FLOW (WINDMILLING PUMP)
- PUMP SPEED BUILD-UP TRANSIENTS
- TWO-PHASE FLOW PRESSURE DROP
- TWO-PHASE FLOW WALL HEAT TRANSFER
- VARIABLE SYSTEM ENTRANCE PROPERTIES, PUMP RPM, AND VALVE POSITIONS
- OPTION FOR STORAGE TANK OR PUMP INLET SYSTEM BOUNDARY