

General Disclaimer

One or more of the Following Statements may affect this Document

- This document has been reproduced from the best copy furnished by the organizational source. It is being released in the interest of making available as much information as possible.
- This document may contain data, which exceeds the sheet parameters. It was furnished in this condition by the organizational source and is the best copy available.
- This document may contain tone-on-tone or color graphs, charts and/or pictures, which have been reproduced in black and white.
- This document is paginated as submitted by the original source.
- Portions of this document are not fully legible due to the historical nature of some of the material. However, it is the best reproduction available from the original submission.

**NASA TECHNICAL
MEMORANDUM**

NASA TM X-71847

NASA TM X-71847

(NASA-TM-X-71847) IRRADIATION EFFECTS ON BETA
10.6 CF PURE AND EUROPIUM DOPED KCl (NASA)
12 p HC \$3.50 CSCI 11G

N76-13296

**Unclas
G3/27 05369**

**RADIATION EFFECTS ON $\beta_{10.6}$ OF
PURE AND EUROPIUM DOPED KCl**

by H. H. Grimes
NASA-Lewis Research Center
Cleveland, Ohio 44135

J. E. Maisel
Cleveland State University
Cleveland, Ohio 44115

and

R. H. Hartford
Shippensburg State College
Shippensburg, Pennsylvania 17257

**TECHNICAL PAPER to be presented at
Fifth Infrared Laser Window Materials Conference
Las Vegas, Nevada, December 1-5, 1975**



RADIATION EFFECTS ON $\beta_{10.6}$ OF PURE AND EUROPIUM DOPED KCl

H. H. Grimes
NASA-Lewis Research Center
Cleveland, Ohio 44135

J. E. Maisel
Cleveland State University
Cleveland, Ohio 44115

and

R. H. Hartford
Shippensburg State College
Shippensburg, Pennsylvania 17257

ABSTRACT

Strengthening of KCl for CO₂ laser window applications may be achieved by irradiation, polyvalent ion doping, recrystallization, or a combination of these methods. These strengthening methods, however, may increase the optical absorption of the material. In addition, hostile radiation environments of electrons, X-rays, or ions will be encountered in E-beam CO₂ lasers, or in space radiation belts.

In this investigation, we determined changes in the optical absorption coefficient as a result of X-ray and electron bombardment of pure KCl (monocrystalline and polycrystalline), and divalent europium doped polycrystalline KCl. The optical absorption coefficients were measured by a constant heat flow calorimetric method.

Both 300 KV X-irradiation and 2 MeV electron irradiation produced significant increases in $\beta_{10.6}$, measured at room temperature. X-irradiation of pure monocrystalline KCl increased $\beta_{10.6}$ by 0.005 cm^{-1} for a 113 MR dose. For an equivalent dose, 2 MeV electrons were found less efficient in changing $\beta_{10.6}$. However, electron irradiation of pure and Eu-doped polycrystalline KCl produced marked increases in adsorption. β increased to over 0.025 cm^{-1} in Eu-doped material for a $30 \times 10^{14} \text{ e}^-/\text{cm}^2$ dose, a factor of 20 increase over unirradiated material. Moreover, bleaching the electron irradiated doped KCl with 649 m μ light produced an additional factor of 1.5 increase. These findings will be discussed in light of known defect-center properties in KCl.

INTRODUCTION

A window material for high power CO₂ lasers must have sufficient strength and an optical absorption coefficient ($\beta_{10.6}$) low enough to permit transmission of the laser beam without heating the material to the point of optical or mechanical failure. These parameters are included in a figure-of-merit for materials for window applications.¹ On this basis, potassium chloride is considered a prime candidate for near-term use despite its low flow stress.

It is known that KCl may be strengthened by irradiation, polyvalent ion doping, recrystallization, or a combination of these methods. However, these same strengthening methods may lead to increased optical absorption in the material. In this investigation, we determined changes in $\beta_{10.6}$ resulting from X-ray and electron irradiation of pure, monocrystalline and polycrystalline KCl, and divalent doped, polycrystalline KCl. In addition to the application to hardening technology, the results from these studies will also bear on the design of E-beam CO₂ lasers, and on the use of high power CO₂ lasers in other radiation environments such as the space radiation belts. The electron doses used in this study were typical of those indicated for hardening. They are also comparable to those which would be achieved in synchronous orbit in a few months. The electron and X-ray levels at the windows in the E-beam laser are undefined, depending strongly on design considerations.

The optical absorption coefficients were measured with a unique, constant heat-flow calorimeter which will be described in the Experimental Section. This device measures the steady state heat loss from a laser irradiated window. The problem associated with window temperature measurement in the adiabatic calorimeter is thus eliminated.

With this device, radiation induced optical absorption was measured in Harshaw laser grade KCl windows. The increased absorption is discussed in light of previous work on color centers in KCl.

EXPERIMENTAL

Figure 1 shows a schematic diagram of the calorimeter system used in this experiment. The beam from a Coherent Radiation 300 watt, CO₂ laser was expanded, collimated, and directed into an isothermal, aluminum vacuum chamber containing a germanium lens, additional collimating irises, the calorimeter, and a beam power meter. The germanium port window, lens, and power meter were all cooled with water circulated from an external reservoir. All elements except the test calorimeter, therefore, were maintained at constant temperature.

The calorimeter which contained the test window was OFHC copper and is shown in Fig. 2. Indium gaskets were used to insure good thermal contact between the test

window and the calorimeter, and between the calorimeter base and the aluminum chamber which served as a constant temperature heat sink. The calorimeter assembly was polished and gold plated to minimize radiation losses, and the interior chamber surfaces were blackened to reduce errors from scattered light. A vacuum of 15μ was maintained in the chamber to prevent convective heat losses. At steady state, the power adsorbed by the test window equals the heat flow from the calorimeter to the heat sink. Calibration runs, using known electrical heating of the calorimeter head, confirmed this equality to within 6% of the measured value.

The heat flow is determined by measurement of the differential temperature between fixed points on the calorimeter support rod. This power is given by

$$P_a = \frac{\Delta T \sigma A}{l}$$

where σ is the thermal conductivity of the copper rod of cross sectional area A . The heat flow results in a temperature difference of ΔT^* between two thermocouples a distance, l , apart. For small absorptions, then, the coefficient, β , can be calculated from

$$\beta = \frac{P_a}{P_t \cdot x} \cdot \left(\frac{2N}{N^2 + 1} \right)$$

where P_t is the transmitted power, x is the window thickness, and N is its refractive index.

Typically, equilibrium was reached in about 90 minutes, approximately three time constants for the sample and calorimeter. In these studies, ΔT never exceeded 10° C for laser beam powers of about 100 watts.

The test windows, fabricated by the Harshaw Chemical Company included laser grade monocrystalline KCl, pure polycrystalline KCl prepared by hot forging, and polycrystalline KCl doped with 0.05 mol % Eu^{++} . The windows were in the form of discs either 5 or 10 mm thick, and either 3.8 or 6.35 cm in diameter. The faces were etched to remove scratches and mechanically polished to a $\lambda/10$ flatness.

Windows were irradiated with 300 KV tungsten X-rays at about 0.25 MR/hr, measured using a commercial r-meter. Only half of the window was irradiated to permit comparison with unirradiated material from the same sample. Electron irradiation at 2 MeV and about 3×10^{-8} amp/cm² was done in vacuum at -60° C. The windows were

* With the laser beam on, slight heating of the empty calorimeter was measured, arising from scattered light in the chamber. This is subtracted from ΔT .

scanned to achieve uniform dose over the irradiated half of the sample. At 2 MeV, electrons will penetrate KCl to approximately 5 mm. In 10 mm samples, β 's were determined on the basis of the first 5 mm penetration.

RESULTS AND DISCUSSION

Figure 3 shows the effect of X-ray irradiation on the absorption of laser light by monocrystalline KCl. The radiation induced change in $\beta_{10.6}$ is plotted as a function of accumulated X-ray dose to 113 MR. The initial value of $\beta_{10.6}$ for this sample was $3.3 \times 10^{-3} \text{ cm}^{-1}$. A linear fit to the data is shown.

Prior to irradiation to 113 MR, it appeared that $\Delta\beta$ was saturating at about $2 \times 10^{-3} \text{ cm}^{-1}$. However, in view of the scatter in $\Delta\beta$ and also by comparison with electron irradiated samples, we believe that a two-stage absorption argument is not justified.

The least squares fits of similar plots for electron irradiated monocrystalline KCl, and pure and Eu-doped polycrystalline KCl, are summarized in Fig. 4. The curve for X-irradiated monocrystalline KCl is included again for comparison. The X-ray dose in e/cm^2 was calculated from the X-ray dose in MR/hr on the basis of total energy deposited in the window for the specific X-ray and electron beams used.^{2,3} This conversion factor was confirmed by the similarity of F-center coloration for equivalent dose. We note that X-rays more efficiently raise β than do electrons for equivalent F-center coloration. This, then implies that the radiation induced increases in β is not simply the result of the F-center band "tail" absorption at 10.6μ .

The rate of β increase with electron dose for polycrystalline KCl is 4.7 times that for monocrystalline KCl. This is consistent with the 4.3-fold increase in F-centers in X-irradiated compressed KCl seen by Hersh and Markham.⁴ However, they also found radiation enhancement of other color centers in plastically deformed KCl. These centers were given as the Cl_2^- molecular-ion and unspecified electron centers which absorb between 0.6 and 1.0μ .

An even greater increase in $\beta_{10.6}$ is seen in Fig. 4 for electron irradiated Eu^{++} -doped polycrystalline KCl. For this material, $\Delta\beta$ was greater than that for pure monocrystalline KCl by as much as a factor of 10. β increases due to electron irradiation to 15 and $30 \times 10^{14} \text{ e/cm}^2$ in two samples were near $3 \times 10^{-2} \text{ cm}^{-1}$, an increase in β of nearly a factor of 20. This is shown in Fig. 5 for samples labeled 1-EPK and 2-EPK. In this figure, we see for sample 1-EPK an indication of saturation of the effect. However, the value of the saturation level observed here contrasts sharply with the saturation value claimed by Magee, Johnson, and Peng⁵. Theirs was more than an order of magnitude lower. If, instead, we assume a linear fit to the data of Fig. 4 in Ref. 5, the rate of increase of $\Delta\beta$ with dose is the same as that for our Fig. 5 within 20 percent. (Correction was made for the electron energy differ-

erence in the two experiments.)

In addition to the large difference in magnitude of the effect, we observe a marked enhancement of $\Delta\beta$ in Eu-doped material. This is contrary to the findings in Ref. 5 which indicate a smaller increase in doped samples. Our increase is consistent with the enhancement of radiation colorability in KCl doped with Ag, Tl, and Pb, found by Delbecq, Smaller, and Yuster.⁶ They attribute their enhancement to increased production of Cl_2^- ions, resulting from metal ions trapping the electrons which normally recombine to annihilate the radiation induced self-trapped holes. This mechanism, then, is similar to that of Ref. 4 for irradiated, plastically deformed material.

The Cl_2^- molecular ion is an effective e-trap and can, on recombination with an electron, produce interstitials and F-centers. It is not likely, however, that the F-centers thus formed are directly responsible for the enhanced β . This is indicated by the previously mentioned disparity between $\Delta\beta$ for KCl, X-ray, and electron irradiated to similar F-center absorptions. Additional evidence is seen in the data of Fig. 5. A 50% increase in $\Delta\beta$ is observed for Eu-doped KCl which was bleached with 649 μ light from a filtered Xenon source after irradiation to 30×10^{14} e/cm². This treatment markedly reduced the F-center coloration while increasing $\Delta\beta$. This effect has also been observed in γ -irradiated⁷ and electron irradiated⁵ pure and Rb doped KCl. More specifically, the data in Ref. 5 indicate a correlation with the F-aggregate, R_2 -center, absorption. Our data are not inconsistent with a F-aggregate mechanism, however, we cannot rule out other possible mechanisms involving, perhaps Z centers⁸, or ionized aggregate centers.⁹

It is also quite possible that the oxidation state of the Eu contributes indirectly to the $\Delta\beta$ mechanism. This is indicated by an annealing study on sample 1-EPK (fig. 5). Annealing this irradiated sample in air at 200° C for 3 hr, which removed all F-center coloration, only decreased $\Delta\beta$ to about 0.006 cm⁻¹. A similar anneal in H₂, however, returned β to near its unirradiated value. Eu⁺⁺ may oxidize in KCl to Eu⁺⁺⁺ state. This process could be reversed by H₂ annealing.

Regardless of the actual mechanism, from a practical viewpoint, the increases in β found in these studies are quite unsatisfactory for high power laser applications. Until we learn the source of the increased β absorption and how to avoid it, care must be exercised to protect KCl windows from excessive ionizing radiation.

REFERENCES

1. M. Sparks and H. C. Chow: High-Power 10.6 μ m Window-Material Figures of Merit with Edge Cooling and Surface Absorption Included. Third Conference on High Power Infrared Laser Window Materials, Nov. 12-14, 1973, AFCRL-TR-74-0085(III) 1973, pp 1083-98.

2. Radiological Health Handbook, Second Ed., Dept. of HEW, Public Health Service, 1970.
3. M. J. Berger and S. M. Seltzer: Tables of Energy Losses and Ranges of Electrons and Positrons. NASA SP-3012, 1964.
4. H. N. Hersh and J. J. Markham: Effects of Plastic Deformation at 300° K on the X-ray Production of Color Centers in KCl at 5° and 78° K. J. Phys. Chem. Sol., Vol. 12, 1960, pp. 207-8.
5. T. J. Magee, N. Johnson, and J. Peng: The Influence of High-Energy Electron Irradiation on the 10.6 μm Absorption of Mixed KCl Crystals. Phys. Stat. Sol. (a), Vol. 30, (1975), pp. 81-6.
6. C. J. Delbecq, B. Smaller, and P. H. Yuster: Optical Absorption of Cl_2^- Molecule-Ions in Irradiated Potassium Chloride. Phys. Rev., Vol. 111, 1958, pp. 1235-40.
7. H. G. Lipson, A. Kahan, and P. Ligor: Effect of Ionizing Radiation on the 10.6 μm Absorption of KCl. Fourth Conference on Infrared Laser Window Materials. Nov. 18-20, 1974. ARPA, 1975, pp. 589-99.
8. S. Radhakrishna and B. V. R. Chowdari: Z-Centers in Rare-Earth Doped Alkali Halides. Phys. Stat. Sol. (a), Vol. 12, 1972, pp. 557-62.
9. W. D. Compton and H. Rabin: F-Aggregate Centers in Alkali Halide Crystals. Solid State Physics. Vol. 16, Academic Press, 1974, pp. 121-226.

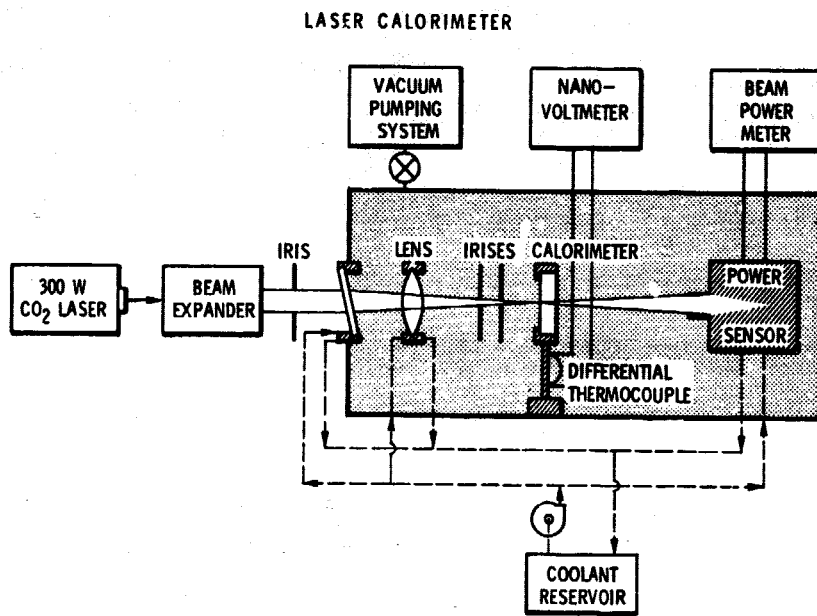

Figure 1. - Schematic of the laser calorimeter system.

PRECEDING PAGE BLANK NOT FILMED

**ORIGINAL PAGE IS
OF POOR QUALITY**

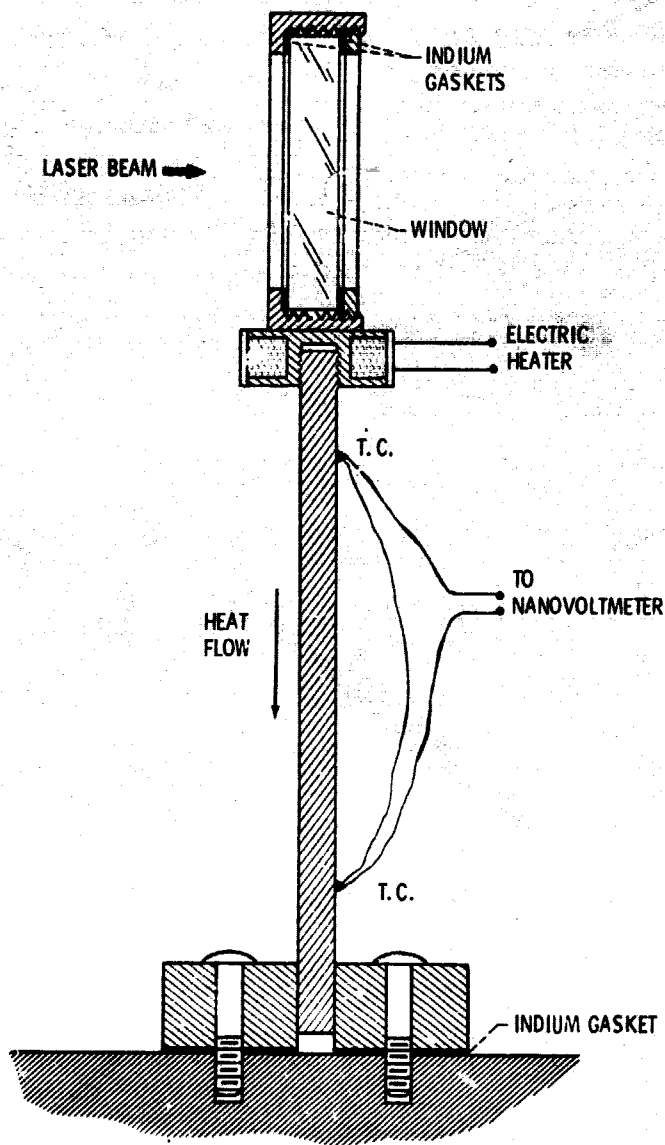

Figure 2 - Constant heat flow calorimeter.

ORIGINAL PAGE IS
OF POOR QUALITY

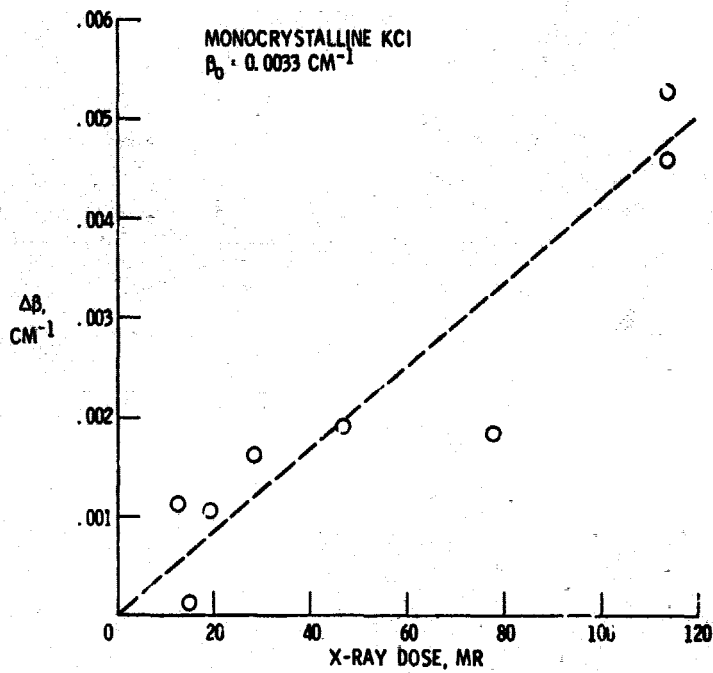

Figure 3 - Change in the optical absorption coefficient at 10.6 μ , $\Delta\beta_{10.6}$ as a function of x-ray dose in megaroentgens for pure, monocrystalline KCl.

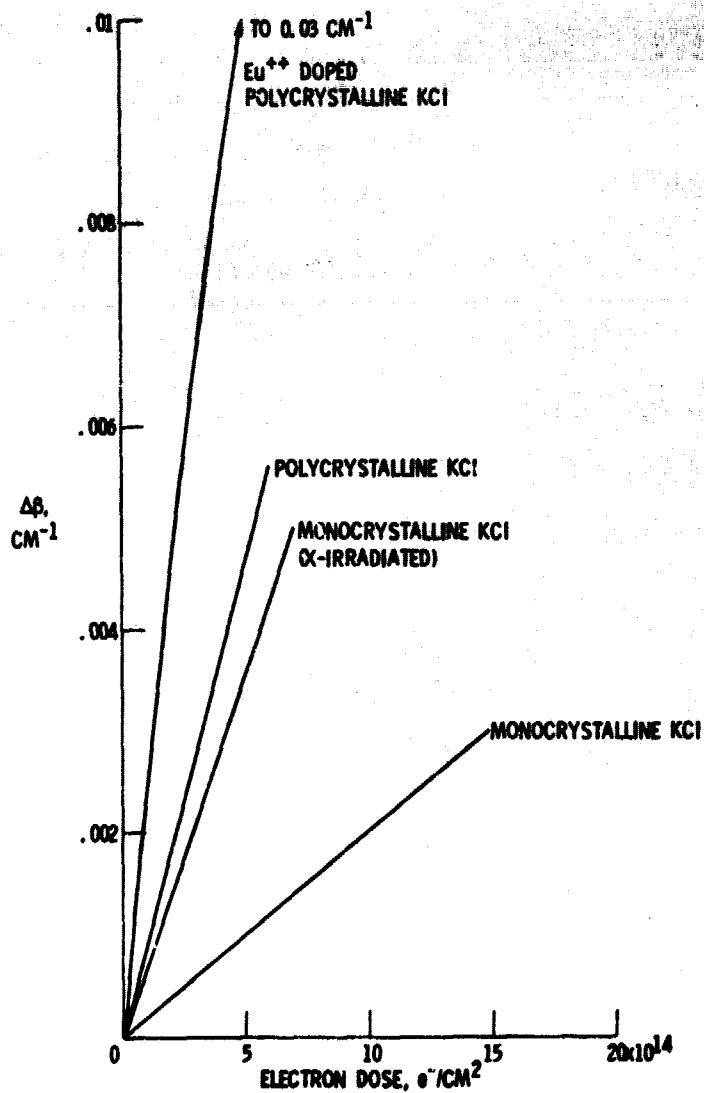

Figure 4 - $\Delta\beta_{106}$ as a function of electron dose for electron and x-irradiated monocrystalline KCl and for electron irradiated pure and Eu^{3+} -doped polycrystalline KCl.

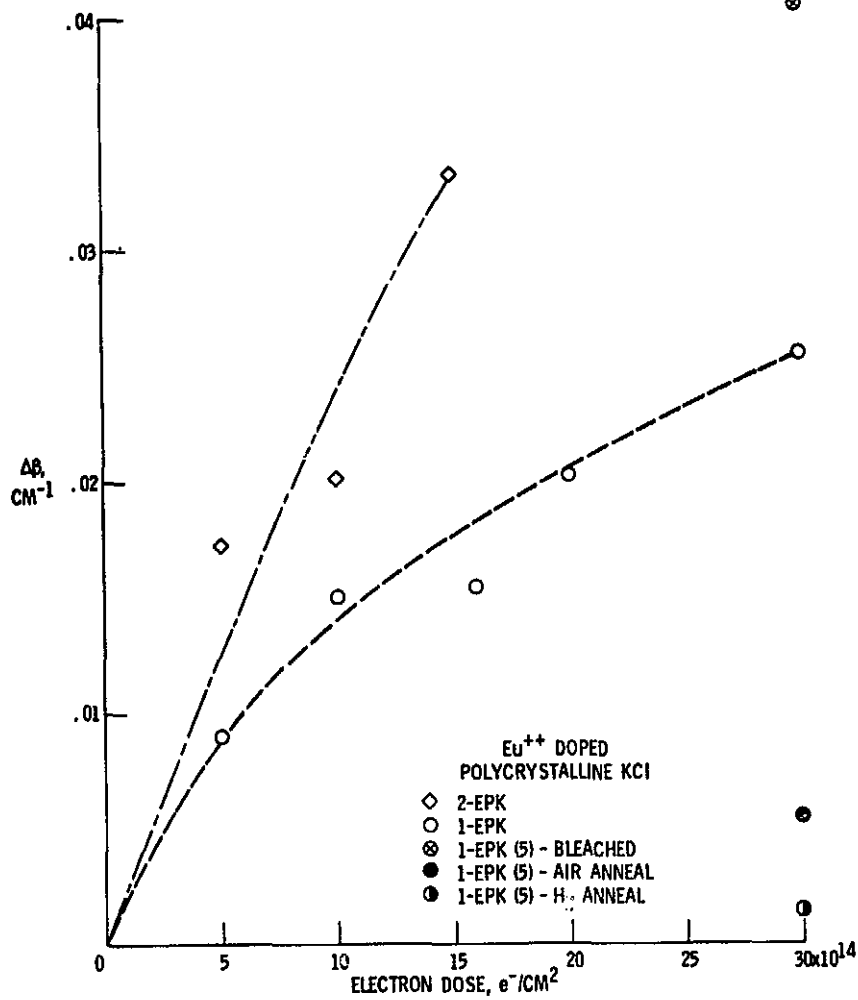

Figure 5. - $\Delta\beta_{10.6}$ as a function of electron dose for two Eu^{++} -doped polycrystalline KCl samples. Also shown is $\Delta\beta_{10.6}$ for sample 1-EPK after irradiation to $30 \times 10^{14} \text{ e/cm}^2$, then:
 ⊗ bleached with 649 mμ light; ● annealed in air;
 ● annealed in H₂.