

## **General Disclaimer**

### **One or more of the Following Statements may affect this Document**

- This document has been reproduced from the best copy furnished by the organizational source. It is being released in the interest of making available as much information as possible.
- This document may contain data, which exceeds the sheet parameters. It was furnished in this condition by the organizational source and is the best copy available.
- This document may contain tone-on-tone or color graphs, charts and/or pictures, which have been reproduced in black and white.
- This document is paginated as submitted by the original source.
- Portions of this document are not fully legible due to the historical nature of some of the material. However, it is the best reproduction available from the original submission.

7  
NGL-31-001-005

**Princeton University**

---

---



---

**Department of  
Aerospace and  
Mechanical Sciences**

(NASA-CR-145895) PULSED ELECTROMAGNETIC GAS  
ACCELERATION Semiannual Report, 1 Jan. - 30  
Jun. 1975 (Princeton Univ.) 79 p HC \$5.00

N76-13919

CSCI 201

Unclas

G3/75

05611

National Aeronautics and Space Administration  
NGL 31-001-005

PULSED ELECTROMAGNETIC GAS ACCELERATION

1 January 1975 to 30 June 1975

Semi-annual Report 634y

Prepared by:

Robert G. Jahf

Robert G. Jahf  
Dean, School of Engineering and  
Principal Investigator

and

W von Jaskowsky

Woldemar F. von Jaskowsky  
Sr. Research Engineer and  
Lecturer

Kenn E. Clark

Kenn E. Clark  
Research Engineer

Reproduction, translation, publication, use  
and disposal in whole, or in part, by or for  
the United States Government is permitted

July 1975

School of Engineering and Applied Science  
Department of Aerospace and Mechanical Sciences  
PRINCETON UNIVERSITY  
Princeton, N.J. 08540

## ABSTRACT

Terminal voltage measurements with various cathodes and anodes in a high power, quasi-steady MPD discharge show that the magnitude of the current at the onset of voltage fluctuations is an increasing function of cathode area and a weaker decreasing function of anode area. Tests with a fluted cathode indicate that the fluctuations originate in the plasma adjacent to the cathode rather than at the cathode surface.

Measurements of radiative output from an optical cavity aligned to examine the current-carrying portion of a two-dimensional, 56 kA MPD discharge reveal no lasing in that region, consistent with calculations of electron excitation and resonance radiation trapping. A voltage-swept double probe technique allows single-shot determination of electron temperature and electron number density in the recombining MPD exhaust flow.

Current distributions within the cavity of MPD hollow cathodes for various static prefills with no injected mass flow are found to replicate distributions measured with injected flows, yielding the important result that the dynamics of the injected flow does not play an important role in the hollow cathode emission process.

## TABLE OF CONTENTS

	Page
Title Page	i
Abstract	ii
Table of Contents	iii
List of Illustrations	iv
Current Student Participation	v
I. INTRODUCTION	1
II. QUASI-STEADY MPD DISCHARGES	2
III. PLASMADYNAMIC LASER STUDIES	11
A. MPD Discharge in a Laser Cavity	11
B. Electron Temperature Measurement	25
IV. HOLLOW CATHODE STUDIES	37
PROJECT REFERENCES	54
GENERAL REFERENCES	72
APPENDIX: Semi-annual Statement of Expenditures	73

## LIST OF ILLUSTRATIONS

	<u>Page</u>
1. MPD geometries	3
2. Onset current $J^*$ versus cathode area	5
3. Fluted cathode	7
4. Onset current for fluted cathode	9
5. Two-dimensional discharge apparatus	13
6. Magnetic field distribution	14
7. Terminal voltage and current	15
8. Current-voltage characteristic	16
9. Voltage-mass flow characteristic	17
10. $V-V_0$ vs. current	19
11. Typical spectra	22
12. Probe circuitry	27
13. Probe response	30
14. Swept probe response	31
15. Probe characteristic	34
16. Probe response with contamination	35
17. Current distribution in HC XII	39
18. Current density profiles, 0.25 kA	40
19. Current density profiles, 0.9 kA	42
20. Current density profiles, 4.7 kA	43
21. Active zone length	44
22. Current density distributions, 0.2 g/sec	46
23. Current density profiles, no flow, 0.25 kA	47
24. Current density distributions, $p = 5$ torr	49
25. Current and potential profiles, 0.25 kA	51
26. Power density profiles, 0.25 kA	53

CURRENT STUDENT PARTICIPATION

<u>Student</u>	<u>Period</u>	<u>Degree</u>	<u>Thesis Topic</u>
BARON, Henry C.	1975-		Hollow Cathode Studies
CAMPBELL, Edward M.	1972-	Ph.D. Cand.	Plasmadynamic Laser Studies
DUTT, Gautam S.	1971-	Ph.D. Cand.	Stimulated Emission of Argon Ion Lines in High Current Discharges
KRISHNAN, Mahadevan	1972-	Ph.D. Cand.	Hollow Cathode Dis- charges
NG, Charles	1974-	B.S.E. Cand.	Spectroscopic Study of Ionization in the MPD Exhaust Flow
PAULINE, Terri	1974-	B.S.E. Cand.	Cathode Emission Pro- cesses in MPD Discharges
RUDOLPH, L. Kevin	1973-	Ph.D. Cand.	Cathode Studies in MPD Discharges
VILLANI, Daniel D.	1969-	Ph.D. Cand.	Power Deposition in MPD Discharges

## I. INTRODUCTION

During the preceding six-month interval, technical papers summarizing our progress in all three areas of investigation, MPD discharges, plasmadynamic lasers and hollow cathodes, were presented at AIAA meetings. In the MPD portion of the program, a summary of the work on current-limiting phenomena was presented at the AIAA 11th Electric Propulsion Conference, March 19-21, 1975 at New Orleans, Louisiana. One graduate student is now working in this area of performance limitations in MPD accelerators. His recent work, included in this report, shows additional encouraging results for MPD devices using argon as a propellant.

In the plasmadynamic laser studies, our program of two complementary approaches continues. The principal results of the first of these, the study of the collisional-radiative recombination mechanism in a three-dimensional MPD exhaust, were reviewed in a paper presented at the AIAA 8th Fluid and Plasma Dynamics Conference, June 16-18, 1975 at Hartford, Connecticut. More recent work in this program has led to the development of a single shot electron temperature measurement technique to aid in determining the electron cooling rates in the recombining flow. The goal of the second plasmadynamic laser project is the direct demonstration of lasing in a unique two-dimensional discharge configuration. In this report, the results of a spectroscopic study of the current carrying portion of the discharge with a resonant optical cavity are detailed.

Like the MPD discharge work, the principal results of the hollow cathode program were presented at the AIAA Electric Propulsion Meeting at New Orleans. The approach outlined in that paper, namely the examination of the active zone length at low currents and mass flows, has been extended to even lower currents. The recent addition of a second graduate student in this program allows a broader examination of current conduction mechanisms in hollow cathodes.



## II. QUASI-STEADY MPD DISCHARGE

### Cathode Studies (Rudolph)

The terminal voltage of an MPD accelerator has been found to exhibit highly oscillatory behavior for discharge currents above a certain value. The onset of these oscillations correlates with the parameter,  $J^{*2}/\dot{m}$ , where  $J^*$  is the onset current at which the oscillations arise and  $\dot{m}$  is the propellant mass flow.<sup>A-1,166</sup> Although earlier investigations have shown that this parameter is a strong function of the cathode geometry,<sup>155</sup> the previous report showed preliminary data indicating that  $J^{*2}/\dot{m}$  also depends weakly on the anode geometry.<sup>166</sup> Recent results support this anode area dependence. The results show that for a 5.0-cm-long, stainless steel cathode, the onset current increases by less than a factor of two as the anode area is decreased by a factor of ten. For larger cathodes the effect becomes even weaker.

Earlier floating probe measurements on several cathodes revealed that the voltage fluctuations originate in the cathode region of the discharge.<sup>166</sup> Unfortunately, these studies were unable to distinguish between a cathode surface effect (related to the electron emission process) and a volume effect in the plasma surrounding the cathode. To differentiate between these two possibilities, the performance of a fluted cathode was investigated, and the results, presented herein, indicate a cathode plasma effect is responsible for the oscillations.

#### A. Discharge Configurations

Figure 1 shows the two anode geometries and examples of various cathode geometries used in this study. The small anode with a surface area of  $250 \text{ cm}^2$  is shown in Fig. 1a. It consists of a 1-cm-thick aluminum plate with an inner surface facing the 5.1-cm-deep discharge chamber, a lip region with a minimum diameter of 10.2 cm, and an outer face with a maximum diameter of 18.6 cm. The outer barrel of the anode, which is

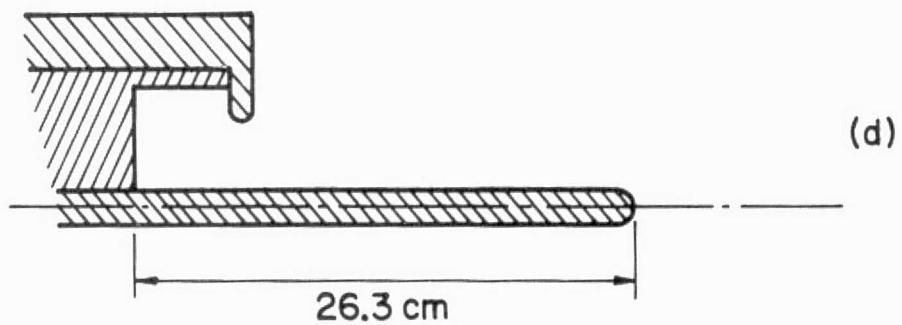
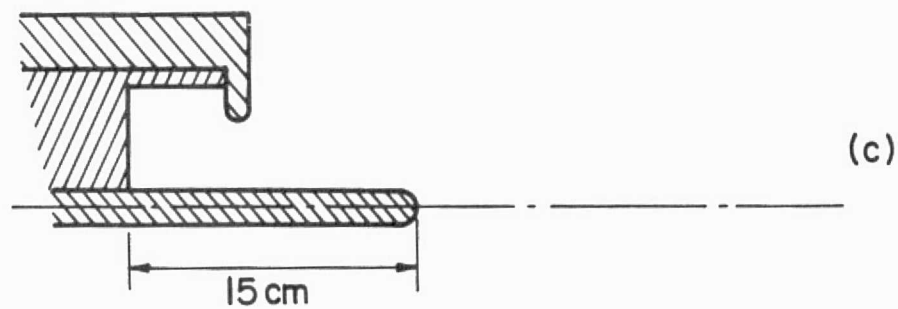
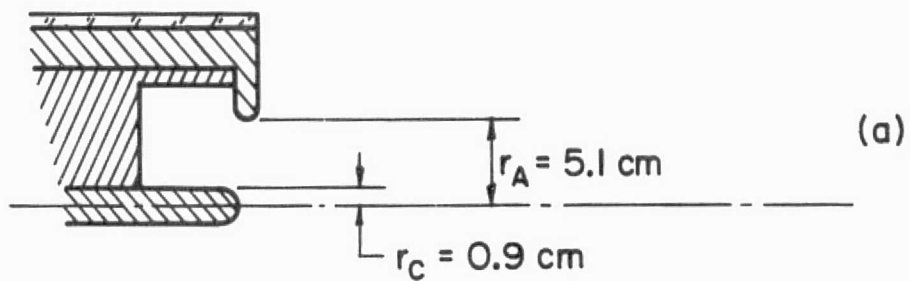

### MPD GEOMETRIES

approximately 34 cm long, is electrically insulated in this geometry. The larger anode has an area of about 2500 cm<sup>2</sup> and is shown in Figs. 1b, c, and d. It is identical to the small anode, with the exception that the outer barrel is no longer insulated. This larger anode has been used in all previous investigations of the voltage fluctuations.

The cathodes were all stainless steel cylinders of various lengths, each with a hemispherical tip. The radius was identical for all cathodes in order to maintain a constant geometric term in the electromagnetic thrust equation,<sup>61</sup> while the length was changed to vary the cathode area.

#### B. Onset Current

Figure 2 shows a graph of the onset current versus cathode area for the large and small anodes. The lower curve, measured with the large anode, has been discussed in previous reports.<sup>166</sup> The upper curve represents the results of the study using the small anode. For all of these data, the mass flow of argon propellant was 6 g/sec.

The results using the small anode are qualitatively similar to those using the large anode except that the entire curve has been displaced upwards. This relatively weak dependence of critical current on anode area is reasonable insofar as changes in the anode can be expected to affect the current and potential profiles throughout the discharge, including the region surrounding the cathode. Nevertheless, the inverse dependence of onset current on anode area presents a logical problem if taken to the extreme of zero anode area. Without further data, it is anticipated that additional current limiting phenomena would become manifest for very small anode areas.

It should be noted that the abscissa in Fig. 2 equivalently represents the cathode length since all data were obtained with cathodes of the same radius, i.e. these data do not allow discriminating between a cathode area effect and a cathode length effect.

FIGURE 2  
AP25-5120

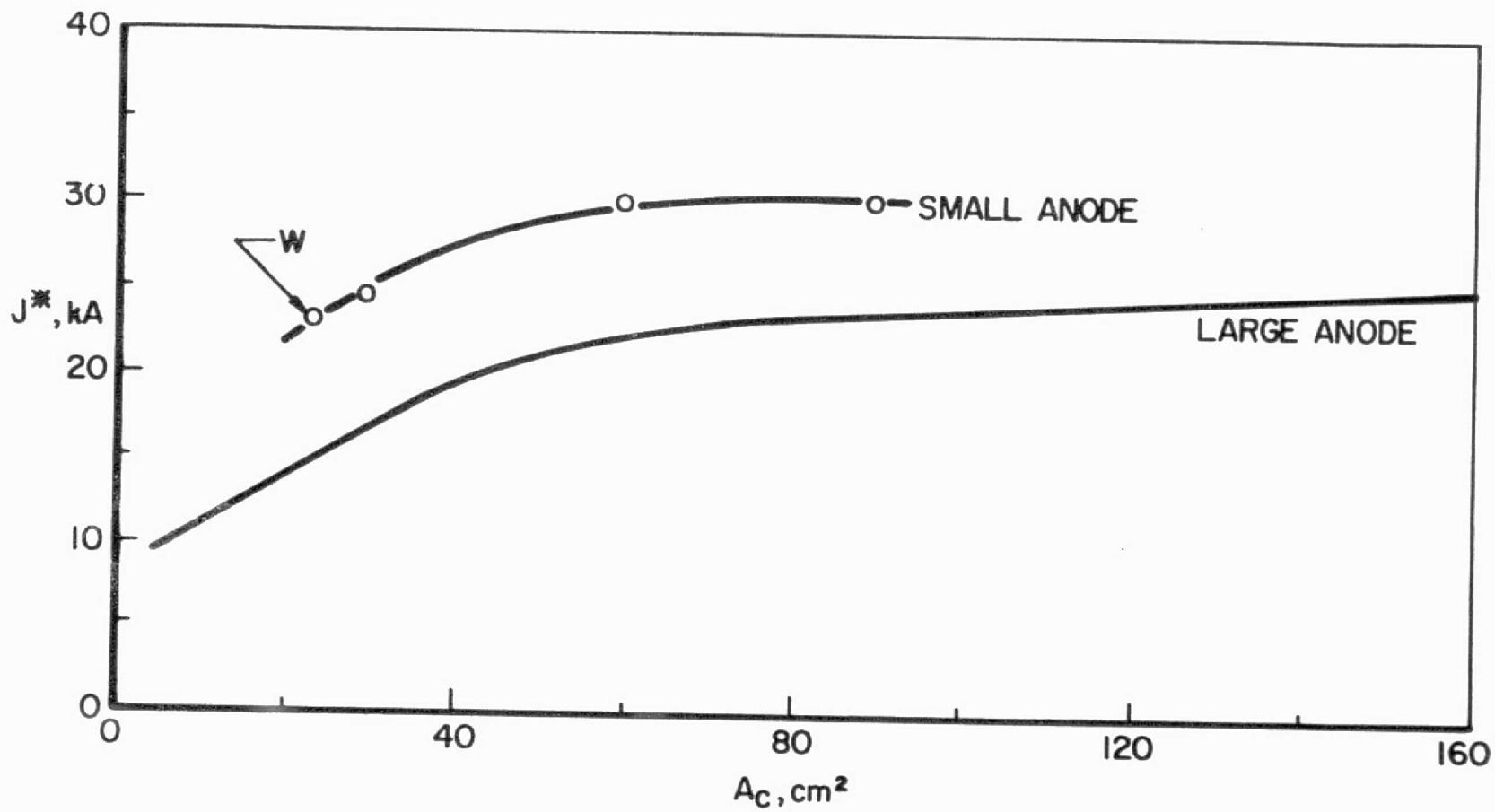

ONSET CURRENT  $J^*$  VERSUS CATHODE AREA

Another interesting implication of the data is that the largest value of the critical current found experimentally (30 kA) gives a value of  $J^{*2}/\dot{m}$  of  $150 \text{ kA}^2 \cdot \text{sec/g}$ . Using this value in the electromagnetic thrust equation yields a specific impulse of 2500 sec, which if achieved in practice provides a significant improvement over the 1250 sec value measured by Boyle<sup>168</sup> and the 850 sec limit originally proposed by Malliaris.<sup>A-1</sup>

Most of the previous data obtained during the study of the onset current dependence on cathode area was done using tungsten cathodes. The switch to stainless steel was made due to the relatively low cost and ease of machining. In addition, because the work functions of the two materials are comparable, it was felt that there would be no difference in the discharge characteristics. To confirm this expectation experimentally, a tungsten cathode was used with the small anode and the result is shown by the data point labelled W in Fig. 2. The critical current for the tungsten cathode falls on the curve generated by the stainless steel cathodes, thereby confirming the interchangeability of tungsten and stainless steel.

### C. Origin of Potential Fluctuations

While the previous floating probe measurements indicated that the voltage fluctuations originate in the cathode region, they did not allow differentiation between a cathode emission process and a plasmadynamic effect centered about the cathode. An experiment was subsequently designed to aid in this discrimination since a cathode emission mechanism would result in a surface area dependence while an effect originating in a plasma layer separated from the cathode surface would be independent of the fine details of the surface.

Figure 3 shows a stainless steel cathode with 12 flutes machined into its surface. The flutes were not carried to the upstream edge of the cathode in order to leave the injection

FIGURE 3  
AP25-5117

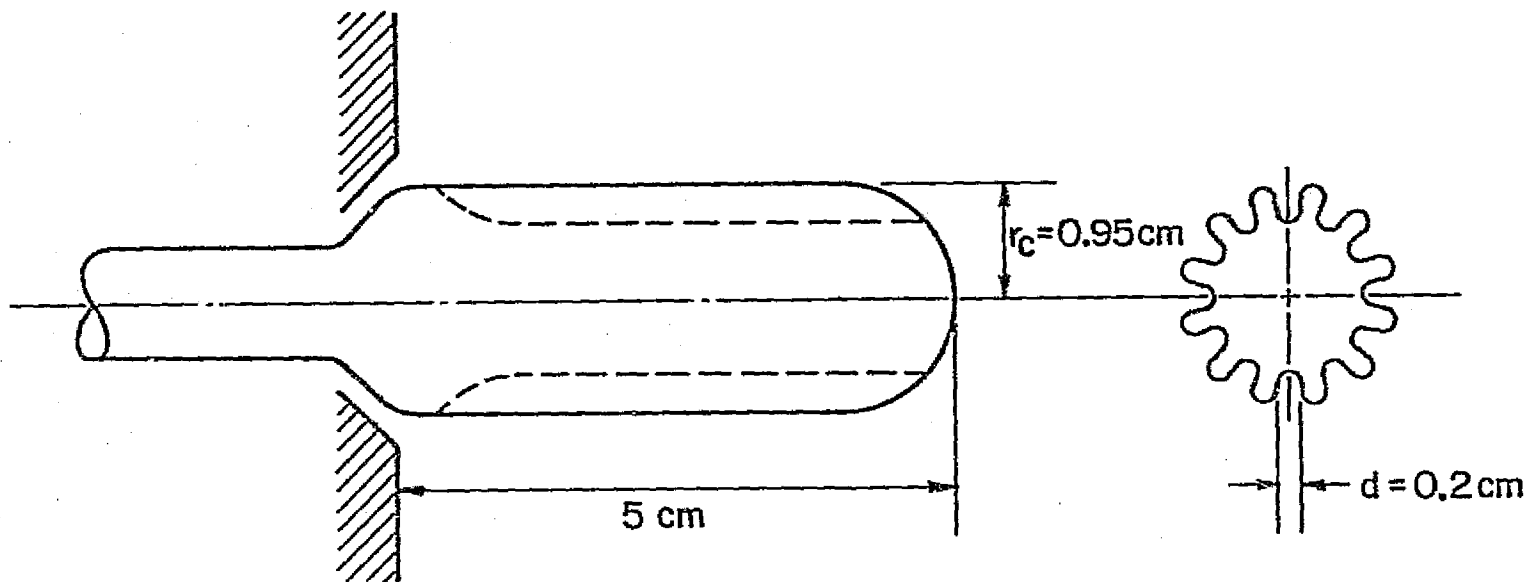

$$\begin{aligned}d &= 0.2 \text{ cm} \\ \lambda_D &= 10^{-3} \text{ cm} \\ \lambda_{e,i} &= 10^{-2} \text{ cm}\end{aligned}$$

FLUTED CATHODE

geometry (which depends on the base of the cathode as a channel wall) unchanged. The 12 flutes are each 0.3 cm deep with a spacing between flutes of 0.2 cm. The surface area of this fluted cathode is approximately  $48 \text{ cm}^2$ , as compared to a surface area of  $30 \text{ cm}^2$  for the previously studied cylindrical cathode of the same outer radius and length.

Estimates of the Debye length in the cathode region of the discharge give a value of  $10^{-3}$  cm. This shows that the emission process takes place essentially at the cathode surface, even within the 0.3 cm deep flutes. The electron-ion mean free path is estimated at  $10^{-2}$  cm, confirming the penetration of the plasma into the regions between the flutes. Any azimuthal variations in electron number density introduced by the fluted cathode should be attenuated over a radial distance of approximately  $10^{-2}$  cm since the random thermal velocity of the electrons is roughly 100 times their radial drift velocity. Thus the plasma conditions surrounding this cathode should be virtually unchanged from that of the standard cylindrical cathode at the same current. This implies that if the oscillatory process originates in the plasma surrounding the cathode, the critical current should be approximately the same for both the fluted cathode and the cylindrical cathode, whereas if the fluctuations originate at the cathode surface, the critical current for the fluted cathode may be up to 50% greater than that of the cylindrical cathode.

The results of the fluted cathode test, shown in Fig. 4, indicate that the critical current for the fluted cathode is the same as that for the cylindrical cathode. The arguments above then lead to the conclusion that the oscillatory process is based on an as yet unidentified plasma phenomena in the region just off the cathode surface and is independent of the cathode emission process. Having thus localized the source of the fluctuations, it follows that all of the onset current data to date, including that of the fluted cathode, can be

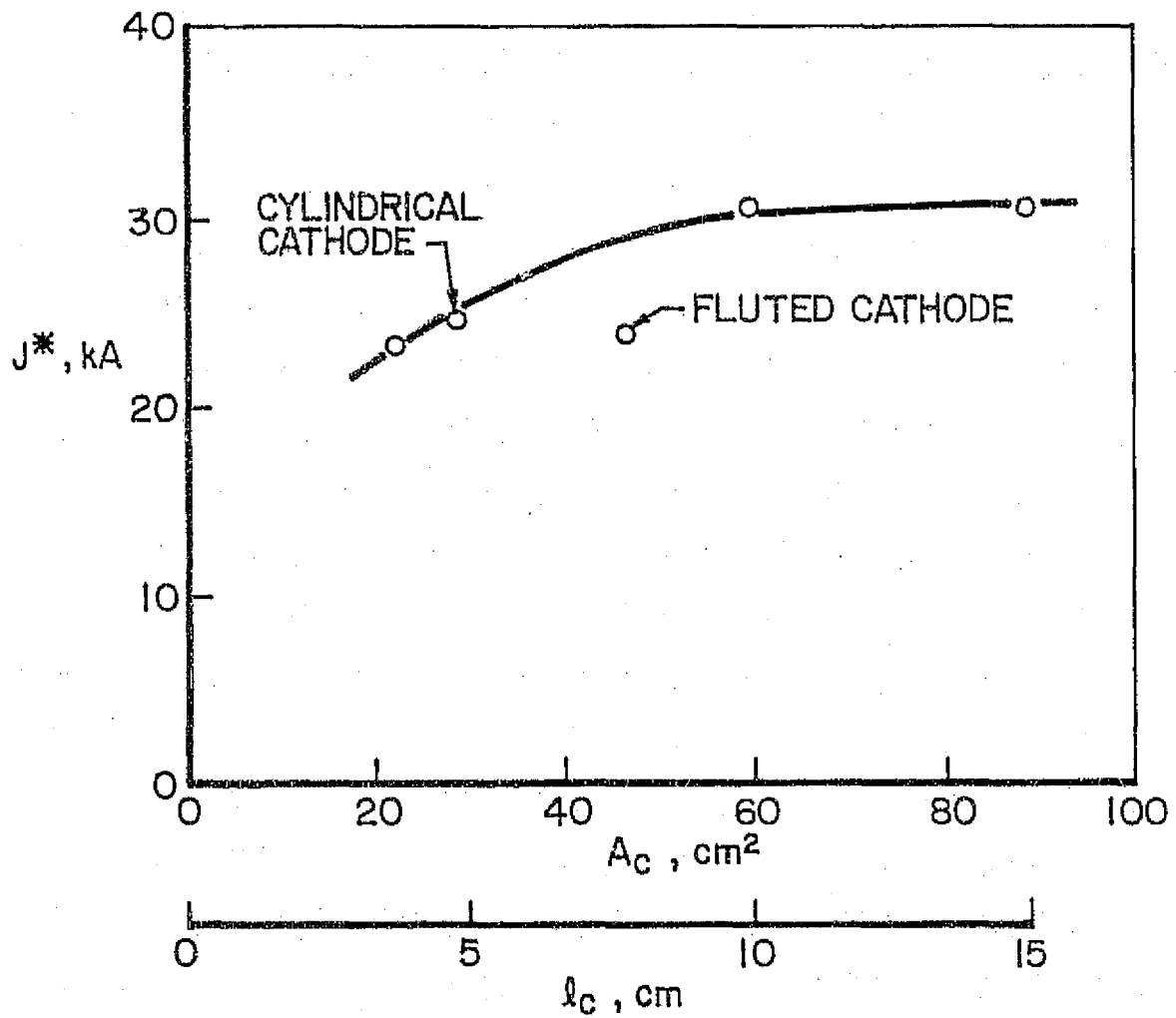

ONSET CURRENT FOR FLUTED CATHODE



reduced to a single graph (for a fixed anode area) by using cathode length rather than cathode surface area as the independent variable.

#### D. Summary

Since the previous report, several experiments have been conducted to improve our understanding of the physical nature and origin of the terminal voltage fluctuations which arise under certain operating conditions in the MPD arcjet. An unexpected result is that the onset current depends on the anode geometry as well as the cathode geometry, in the inverse direction, although the anode dependence is much weaker. Experiments with a fluted cathode have shown that the fluctuations originate in the plasma surrounding the cathode rather than at the cathode surface itself. Further studies are being pursued to delineate more sharply the region from which the oscillations first arise.

## III. PLASMADYNAMIC LASER STUDIES

## A. MPD Discharge in a Laser Cavity (Dutt)

Previous semi-annual reports<sup>159,166</sup> have followed the progress of a set of experiments intended to determine directly whether lasing can be sustained in the discharge and exhaust regions of an MPD accelerator. The discharge apparatus is a two-dimensional version of the conventional MPD accelerator with parallel plates as electrodes. A direct evaluation of lasing is possible by placing the plasma region under consideration within a resonant optical cavity. The use of a cavity avoids the experimental difficulties sometimes associated with the direct measurement of the small signal gain. Furthermore, the two-dimensional geometry, if sustaining a uniform discharge, can reduce to a minimum the effects of variation of plasma properties and emission coefficient along the optical axis of the cavity.

This report briefly describes the most recent configuration of the apparatus, and some of the operational characteristics of the discharge. A search for lasing was conducted in some parts of the discharge and the results are also summarized.

## 1. Resonant Cavity and Discharge Apparatus

The resonant optical cavity remained as described in the previous semi-annual report.<sup>166</sup> It consists of 2 concave mirrors of reflectivity 99.7% and 97% in the wavelength range 0.4 to 0.53  $\mu$ . Their separation is slightly larger than their radius of curvature, 147 cm. The cavity can be aligned externally using a He-Ne laser.

The discharge apparatus is a 45-cm-wide parallel plate configuration consisting of two 10-cm-long anodes on either side of a 5-cm-long cathode, all made from aluminum. In its present form, the lateral edges of the electrodes are recessed

into 40-cm-high by 56-cm-long insulating side plates coated with boron nitride as shown schematically in Fig. 5. In an earlier version of this device, these sidewalls were very small (10 cm x 5 cm) and extended only as far as the electrodes.

## 2. Experimental Results

### a. Discharge Characteristics

The discharge characteristics of this configuration were established earlier in the development of this program. The main concern was the achievement of a laterally uniform current distribution within the discharge. This is a prerequisite for lateral uniformity of the emission coefficient across the discharge. It has been demonstrated that for this electrode configuration, the discharge occupies the entire width of the electrodes only at currents above 40 kA. For these conditions, with the small insulating sidewalls, measurements using a magnetic probe indicated that the current density was a maximum near the center of the electrodes and decreased towards the edges. In the present discharge apparatus with the larger insulating sidewalls, the current distribution is more uniform than before, as shown in Fig. 6.

Another useful indicator of discharge behavior is the terminal voltage. Oscillograms of terminal voltage  $V$  were recorded for various total currents  $J$  and mass flows  $\dot{m}$ . The voltage was found to be quasi-steady in most cases, a typical trace of which is shown in Fig. 7 for a mass flow of 20 g/sec.

The variation of the quasi-steady voltage with current is shown in Fig. 8 for a mass flow of 11.4 g/sec, and the variation with mass flow is shown in Fig. 9 for a current of 56 kA. An extrapolation of the curve in Fig. 8 to  $J = 0$  indicates that  $V(J = 0) \equiv V_0 = 50$  V at 11.4 g/sec.  $V_0$  has been identified as the sum of the cathode and anode fall voltages,

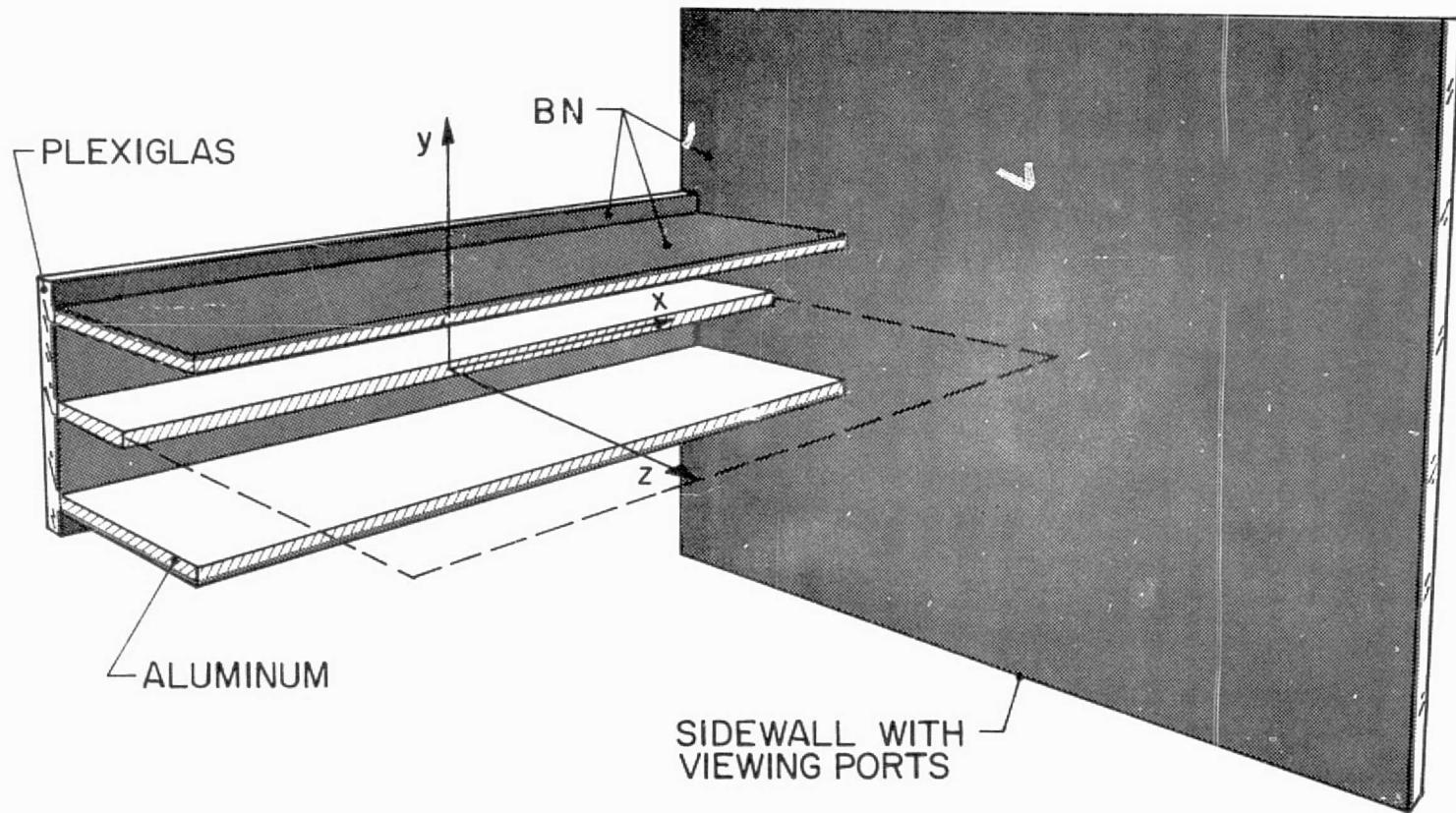
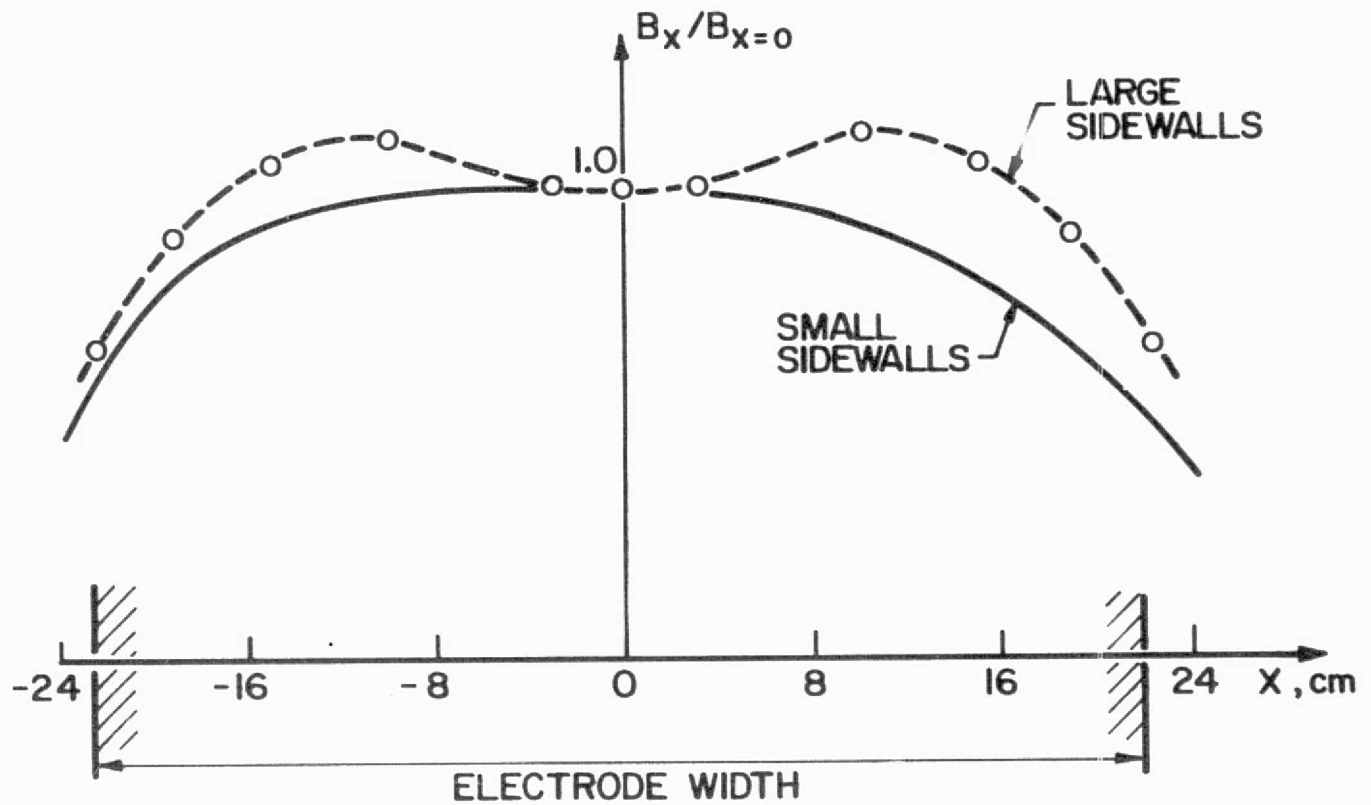
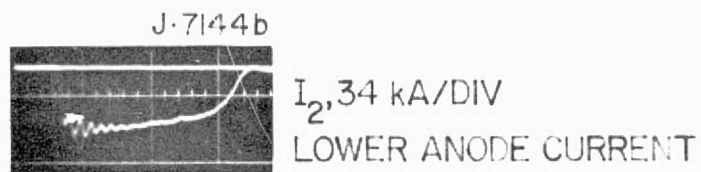
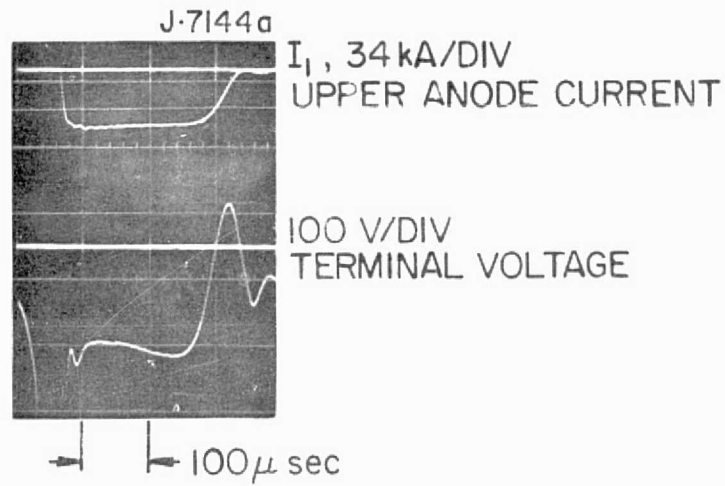

FIGURE 5  
AP 25-5133

TWO DIMENSIONAL DISCHARGE APPARATUS



MAGNETIC FIELD DISTRIBUTION  
 $J = 56 \text{ kA}$ ,  $y = 2 \text{ cm}$ ,  $Z = 5.1 \text{ cm}$



TERMINAL VOLTAGE AND CURRENT  
 $J = 56 \text{ kA}$ ,  $\dot{m} = 20 \text{ g/sec}$

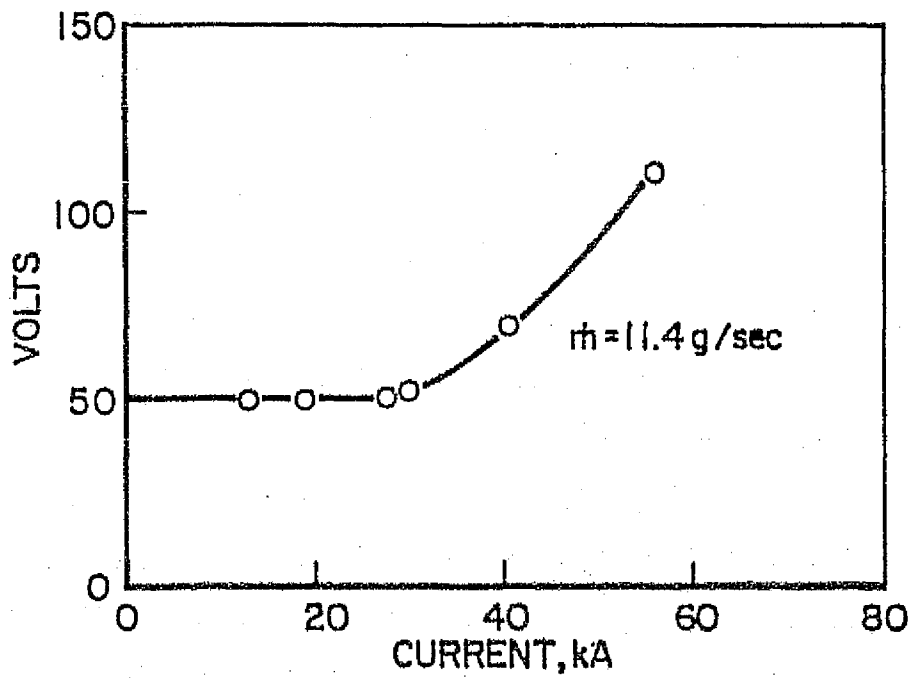

CURRENT-VOLTAGE CHARACTERISTIC

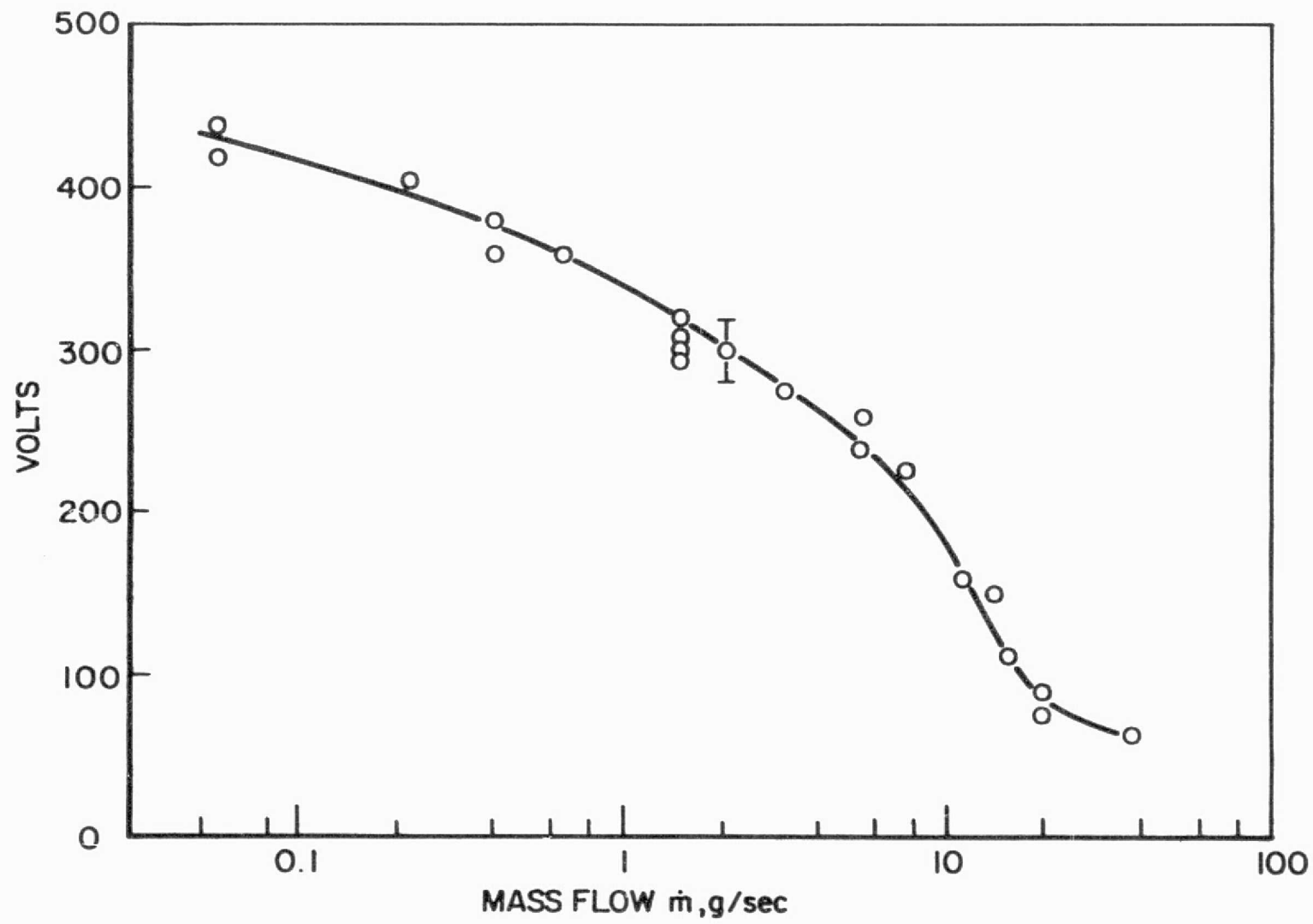

VOLTAGE-MASS FLOW CHARACTERISTIC, J = 56 kA

FIGURE 9  
AP25-5141



present even if the interelectrode space has zero resistance.<sup>163</sup> Log-log plots of  $V - V_0$  vs  $J$  are straight lines as shown in Fig. 10 for mass flows of 11.4 and 25.9 g/sec, and can therefore be represented in the form

$$(V - V_0) = k J^n \quad (1)$$

where the exponent  $n$  is dependent on the mass flow.

Magnetic field and terminal voltage measurements provide general information about the discharge characteristics. In order to gain further insight into the species distribution in succeeding levels of ionization, spectroscopic diagnostics were employed.

#### b. Spectroscopic Study

The insulating sidewalls of the discharge apparatus have openings with removable plugs which permit optical sighting of the plasma transverse to the discharge (along the  $x$  direction in Fig. 5). Using these openings, spectra can be recorded at several locations within the current conducting region and in the exhaust plume. In addition, the resonant cavity can be positioned to enclose these same locations, and spectra can be recorded through its output mirror, which transmits 3% of the light.

If lasing occurs, then the radiation intensity in the laser lines is much greater than in the non-lasing transitions. This would be immediately obvious in spectra photographed through the output mirror of the cavity. A spectrum photographed at the same location but without the cavity would produce a very different distribution of line radiances. Therefore the event of lasing can unambiguously be demonstrated by this comparison of emitted spectra.

To aid in the selection of suitable transitions where lasing may be expected, it is useful to review briefly the processes that can lead to overpopulation of the upper level

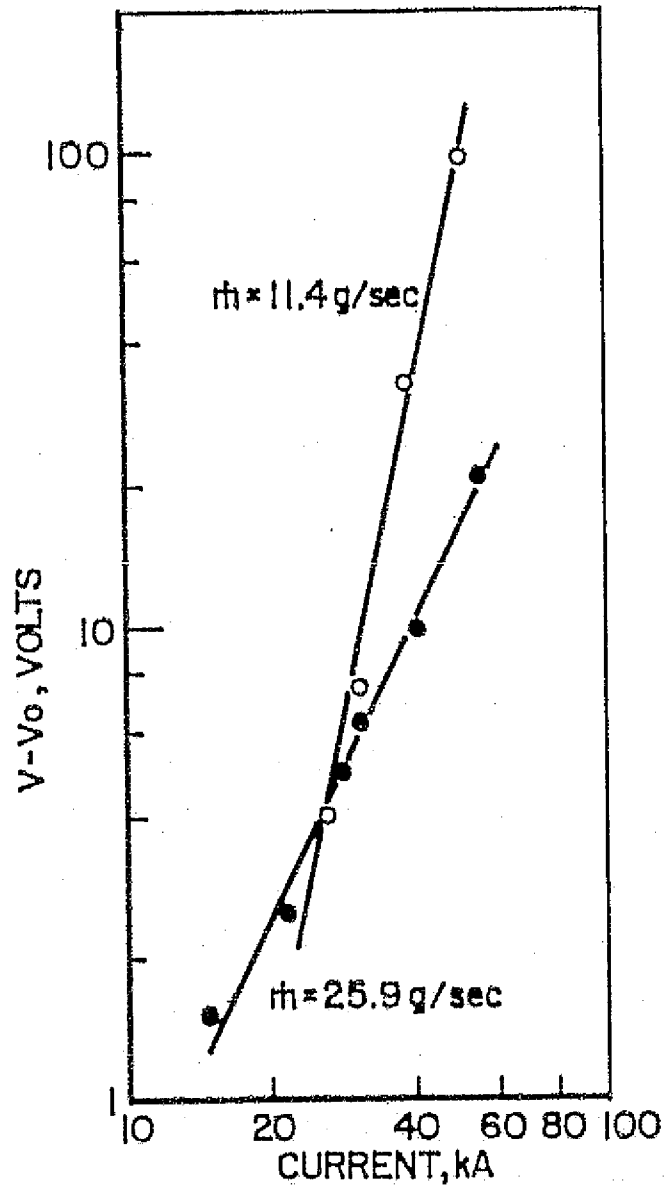
V-V<sub>0</sub> vs CURRENT

of a laser transition. One such process is the excitation mechanism postulated for the operation of conventional argon ion lasers.<sup>A-2</sup> In these devices, the upper level is populated by inelastic collisions between energetic electrons and argon atoms in their ground state. This process may proceed by either a one-step excitation directly to the upper laser level or by a two-step excitation with the ion ground level serving as an intermediate state. Theoretical estimates and some experiments indicate that the one-step excitation is significant only for current densities  $\geq 500 \text{ A/cm}^2$ , assuming an electron temperature sufficiently high to overcome the threshold energy for this process (35.5 eV).<sup>A-3</sup> At current densities in the neighborhood of the threshold current density for lasing,  $50 - 70 \text{ A/cm}^2$ , the two-step process is dominant, but even this mechanism requires a mean electron energy in excess of about 3 eV to sustain an adequate population inversion in conventional ion lasers.<sup>A-4</sup> Because the current density anticipated in the two-dimensional device is on the order of  $100 \text{ A/cm}^2$ , the two-step excitation process may be capable of producing inversions in the current carrying portion of the MPD discharge.

An alternate process for creating inversions is the recombination of a dense plasma of low electron temperature. In this case, the inversion is fed from higher lying levels of the same species or by recombination from the next higher state of ionization.<sup>A-5</sup> Although lasing in argon as a result of pumping by this process has not yet been successfully demonstrated, estimates of the inversion ratio made in this laboratory indicate that the requisite low electron temperature and the high electron density exist within the expanding plume of the MPD exhaust flow.<sup>166</sup>

The configuration of the discharge apparatus permits spectroscopic diagnosis of both the discharge region, where elevated electron temperatures may create inversions by

excitation from lower levels, and the exhaust flow where population inversion by recombination may predominate. During the period covered by this report, the possibility of lasing was investigated only within the discharge region.

Spectra were photographed both with and without the resonant cavity. The locations where spectra were taken through the resonant cavity are designated by their  $y, z$  coordinates as (0, 0.95 cm); (0, 3.81); (0, 10.8); (1.80, 6.90); (2.92, 2.16) and (4.05, 9.13). Reference spectra, photographed without the cavity, were also recorded at some of these locations. The  $y$  and  $z$  coordinates of the optical axis are defined in Fig. 5 where the origin of the coordinate system is the center of the front edge of the cathode.

The study was confined to a current level of 56 kA where the discharge is known to distribute itself uniformly across the width of the electrodes. The other variable in the control of the experimenter, the injected mass flow, was varied from 0.55 g/sec to 55 g/sec.

Two spectra, typical of those taken without the cavity, are shown in Fig. 11 for mass flows of 20 and 54 g/sec. Most of the lines in these spectra, which cover the range from 0.45 to 0.5  $\mu$ , correspond to 4s - 4p transitions in the argon ion, AII. Some weak lines of AI in this spectral region do not appear in Fig. 11, but since these lines are not generally prominent, a definite statement of the relative abundance of AI and AII cannot be made from these spectrograms.

Spectra taken through the output mirror of the cavity exhibit (at a considerably reduced intensity) about the same intensity distribution between different lines and between the different mass flow rates as observed without the cavity. It must therefore be concluded that no lasing was observed for these discharge conditions at these locations.

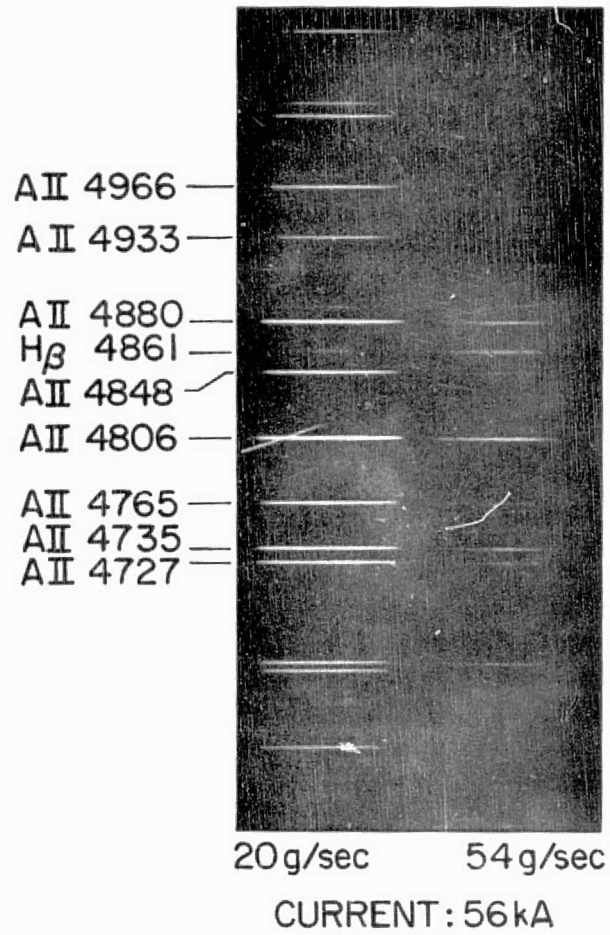
ORIGINAL PAGE IS  
ON MICROFILM

TYPICAL SPECTRA

FIGURE II  
AP25·P·567

### 3. Discussion

One explanation for the absence of lasing in the discharge region may be the excitation rates, which are based in turn on cross sections for electron impact excitation of ions. In order to correlate the results of the present investigations with conventional argon ion laser operations, the current density and the ratio of electric field to pressure,  $E/p$ , can be compared. It has been previously stated that the current densities calculated from magnetic field measurements are typically 50 to 100  $A/cm^2$  in the MPD discharge, as compared to threshold current densities for lasing of 50 to 70  $A/cm^2$  in conventional ion laser operation. The  $E/p$  parameter has been found useful in correlating argon ion laser operation and is therefore used here to compare the present work with known laser conditions. The pressure within the discharge region was estimated from known flow rates to be 0.3 to 5 torr, a range which overlaps typical ion laser pressures of 0.05 to 0.5 torr. However, the electric fields estimated from terminal voltage measurements indicate that for this discharge configuration  $E/p$  is usually less than 0.2  $V/cm \cdot torr$ , which is significantly lower than the  $E/p$  values observed in ion lasers of about 25  $V/cm \cdot torr$ .

The energy gained by an electron in an electric field is proportional both to  $E$  and to the mean free path between energy absorbing collisions. Since the mean free path is inversely proportional to gas pressure, the electron energy is proportional to  $E/p$ . Therefore, the low  $E/p$  in the present experiments may imply an electron temperature too small to sustain a significant population inversion.

The lower  $E/p$  in the MPD device results, in the first instance, from the low voltage in the MPD arc compared to the higher voltage of the glow discharges in conventional ion lasers. Figure 9 shows that it is possible to increase the terminal voltage in the MPD discharge by simply decreasing the mass flow. However, even the modest increases in  $E$  field that

might be realized by this procedure are counteracted by the measured trend for the current contours to bow further downstream as mass flow decreases, thus decreasing the E field by increasing the current path length.

A second possible cause of the absence of a population inversion is resonance trapping of the lower level of the transition. The lower level of the  $0.4880 \mu$  AII laser transition normally depopulates by radiative decay to the ion ground state. This resonance transition has a high probability,  $A_1 = 2.64 \times 10^9/\text{sec}$ , when compared to that of the laser transition itself,  $A_{21} = 6.59 \times 10^7/\text{sec}$ , a disparity which helps to maintain a population inversion even when excitation to the lower level is comparable to excitation to the upper level. However, if there are a large number of particles in the ground state, then the resonance radiation may become trapped, leading to a decreased effective probability of decay for the lower level and a consequent reduction or elimination of the inversion. The detrimental effects of resonance trapping can be expected to increase with plasma dimensions since the greater the distance that the resonance radiation has to travel before leaving the plasma, the greater is its probability of reabsorption and trapping.

Effects of resonance trapping in our discharge configuration can be expected to be severe compared to conventional ion lasers. The ion laser, usually maintaining the discharge in a thin tube, is of very small lateral extent ( $< 1$  cm typically) and there is consequently little resonance trapping in the active volume. The large dimensions (20 cm minimum) of the present discharge configuration precludes easy escape of resonance radiation before reabsorption.

In conclusion, a combination of low electron temperature and excessive resonance trapping offers a possible explanation for the absence of lasing in the current conducting region of the MPD discharge. Similar spectroscopic studies are presently

in progress in the expanding region of the MPD exhaust, where the collisional-radiative recombination model appears to be more promising for producing an inversion.

#### B. Electron Temperature Measurement (Campbell)

The goal of the plasmadynamic laser program is the understanding of the relaxation processes which occur in the exhaust plume of a high power, quasi-steady MPD arc. In a sufficiently rapid expansion, i.e. one in which the electron temperature relaxes in a distance short compared to the recombination length of the plasma, these processes can lead to population inversions between bound electronic states of the accelerated species.<sup>A-6</sup> Although theoretical studies for hydrogen have specified a range of electron density and temperature for which lasing is possible by this collisional-radiative recombination mechanism, similar calculations have not been performed for argon due to its complex internal structure. It is thus of interest to determine experimentally the electron temperature profile in the exhaust flow, from which the electron cooling rate can be deduced.

In the past the electron temperature in the quasi-steady MPD flow has been measured using a double Langmuir probe technique. The voltage-current characteristics for these probes were constructed point-by-point by applying a fixed voltage to the probe electrodes from a small capacitor bias circuit and then measuring the probe current during the discharge.<sup>163</sup> The determination of the electron temperature at a single location thus required many tens of shots in order to guarantee probe reproducibility and to establish the requisite accuracy of the characteristic.

For a complete mapping of the electron temperature distribution such as is planned in the plasmadynamic laser program, a new technique has been developed in which the voltage bias on the double probe is swept at a preselected time and



rate during the discharge. This method, discussed below, allows a complete characteristic to be generated with a single firing of the arc.

### 1. Probe and Circuit Description

The double probe used in this study consists of two equal-area tungsten wires,  $7.6 \times 10^{-3}$  cm in diameter, mounted in a quartz support. The wires have an aspect ratio of 100 to avoid end effects, and have a separation of 100 diameters to insure negligible interaction between the two electrodes.

A special voltage biasing unit has been developed for these measurements capable of providing either a free-running sawtooth waveform or just 1 to 4 segments of this waveform. The amplitude can be varied from -20 to +20 volts, the sweep time per segment can be as short as 50  $\mu$ sec (compared to a discharge time of  $\frac{1}{2}$  msec), and in the partial segment mode, the time of voltage sweep initiation can be delayed with respect to an initial timing mark.

A schematic illustration of the double probe circuitry is shown in Fig. 12. Probe current was monitored with a Tektronix type 6042 current probe, and probe bias was measured differentially using two Tektronix P-6013 (1000 x) voltage probes. The probe voltage sweep was triggered by a Hewlett-Packard pulse generator which was delayed several hundred microseconds with respect to discharge initiation to allow the development of steady plasma conditions at the probe location. For most of the data reported here, only one segment of the sawtooth (a linear ramp) was used, i.e. the bias circuit maintained a constant negative bias on the probes until triggered, at which time it swept to a bias of equal amplitude but opposite sign.

### 2. Data Reduction

Using the Debye length  $\lambda_D$ , the smallest mean-free-path  $\lambda$ , and the probe radius  $R$ , it is convenient to form the

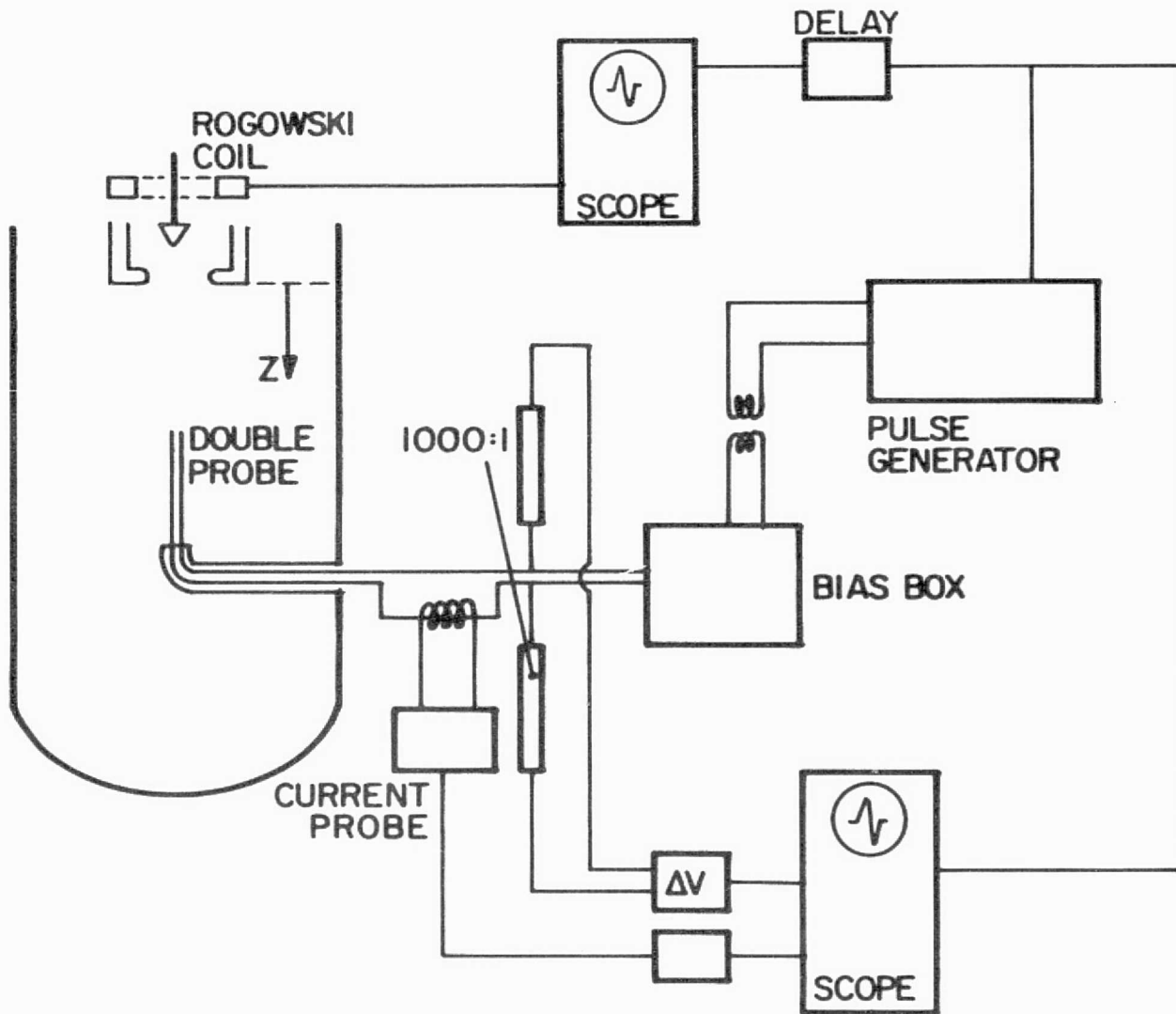

PROBE CIRCUITRY

FIGURE 12  
AP25-5143

dimensionless parameters  $\lambda_D/R$  and  $\lambda/R$  which serve to define the regimes where an electric probe can operate. Using values of the electron temperature and number density expected in the exhaust plume, upper and lower bounds of these ratios are:

$$8.7 \times 10^{-4} < \lambda_D/R < 8.7 \times 10^{-2} \text{ and } 0.25 < \lambda/R < 40.$$

From the bounds of  $\lambda_D/R$ , it can be concluded that the probe will be operating in the thin sheath regime. However, because the Knudsen number,  $\lambda/R$ , may be of the order 1, the shadowing effect of the probe must be considered, i.e., the probe does not subtend a negligible solid angle at the point of the last charged particle collision before absorption by the probe. When severe, this problem is manifest by the lack of a linear relation between the log of the electron current and the probe bias in the electron retarding region of the characteristic, thus prohibiting the determination of electron temperature in the conventional manner.

Talbot, et al, have shown that an accurate value for  $T_e$  can still be obtained from a double probe when operating in a transition regime.<sup>A-7</sup> From their results, the electron temperature can be found from the following relation

$$T_e \text{ (}^\circ\text{K)} = 11,600 \left\{ \left[ \begin{array}{cc} \frac{j_1 j_2}{j_1 + \left(\frac{A_2}{A_1}\right)} & j_2 \end{array} \right] \left( \frac{A_2}{A_1} \right) \left( \frac{\partial V}{\partial I} \Big|_{V=0} \right) (1 + \sigma) \right\} \quad (2)$$

where  $A_1$  and  $A_2$  are the areas of the two probes,  $j_1$  and  $j_2$  are the ion saturation currents,  $\partial V/\partial I$  is the inverse slope of the characteristic, and  $\sigma$  is a correction factor dependent on

$\lambda_D/R$ ,  $T_e/T_i$  and the probe aspect ratio. This relation is essentially the collisionless result obtained by Johnson and Malter<sup>A-8</sup> using the equivalent resistance method, modified by the correction factor  $1 + \sigma$ . For the entire range of plasma parameters expected in the plume,  $\sigma$  is of the order of  $10^{-2}$ , and thus the classical theory can be used while incurring an error of only a few percent.

The probe axis for all tests was aligned with the local velocity vector. The resulting V - J characteristic is identical to that which would be obtained in a stationary plasma provided that

$$\zeta = \frac{l}{\lambda_D} \frac{(kT_e/m_i)^{1/2}}{u} \gg 1 \quad (3)$$

where  $l$  is the probe length,  $m_i$  the ion mass, and  $u$  the plasma velocity. <sup>A-9, A-10</sup> For the present case,  $\zeta = \mathcal{O}(10^3)$  verifying that the characteristic measured in the flowing plasma is valid.

Figure 13a shows a record of the probe current (upper trace) and the arc current (lower trace). The probe bias for this case was fixed at a value sufficiently large to produce ion current saturation. It can be seen that following the passage of the initial plasma front, the probe current is steady for approximately 500  $\mu$ sec. Therefore, it was decided to trigger the voltage sweep approximately 600  $\mu$ sec after discharge initiation. Figure 13b shows an expanded trace of the arc current, with the region where the probe characteristic was measured highlighted by increased luminosity. The probe current, taken for a fixed bias on a 20-times expanded time scale during the highlighted portion of Fig. 13b and displayed in Fig. 13c, shows that the ion saturation current is steady over the interval in which the voltage is swept.

Figure 14 shows a typical record of the probe voltage and current over a 100  $\mu$ sec interval during which the bias was swept from -4 to +4 volts. Because the voltage increases linearly in time, the lower trace in Fig. 14 represents the current-voltage characteristic of the double probe multiplied by a scale factor which is constant and depends on the sweep rate. Thus the electron temperature can be obtained from Eqn. 2 (without the small correction), using the saturated current densities from the oscillogram and calculating the

ORIGINAL PAGE IS  
OF POOR QUALITY

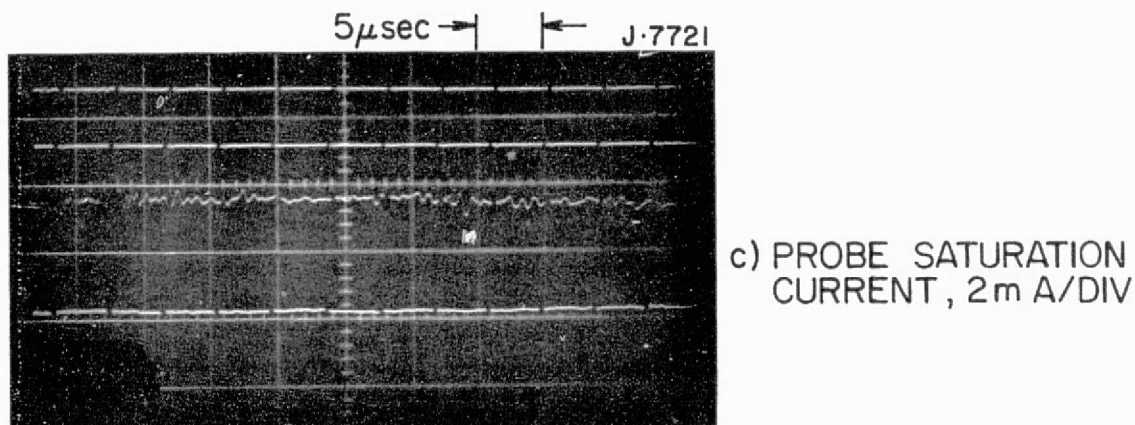
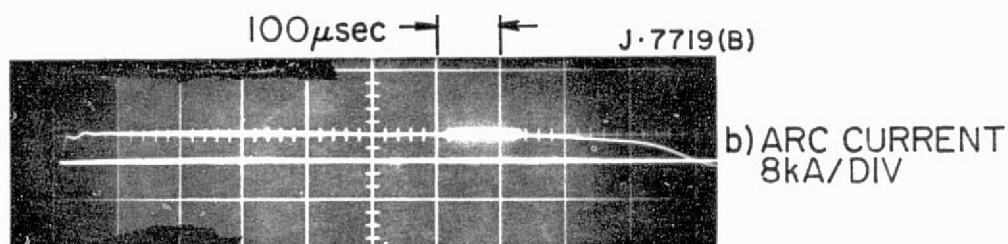
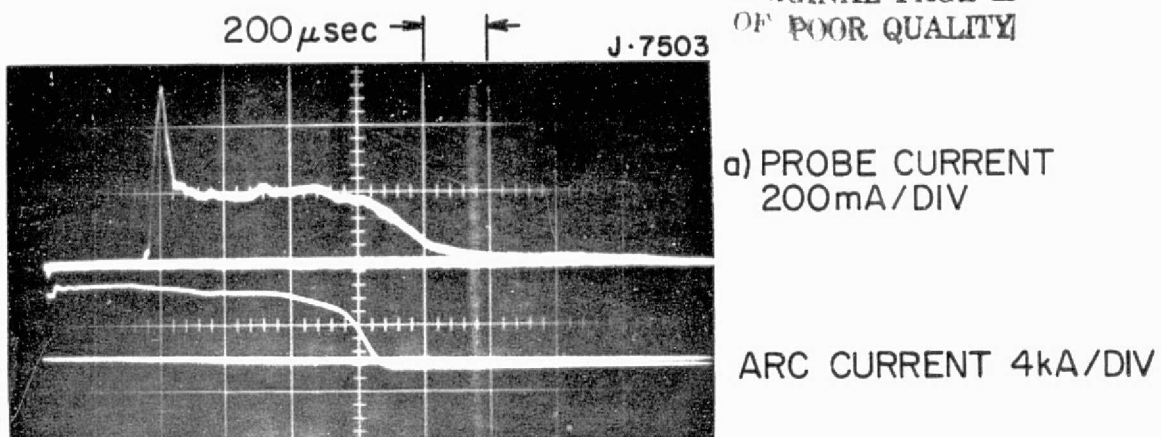

PROBE RESPONSE

ORIGINAL PAGE IS  
OF POOR QUALITY

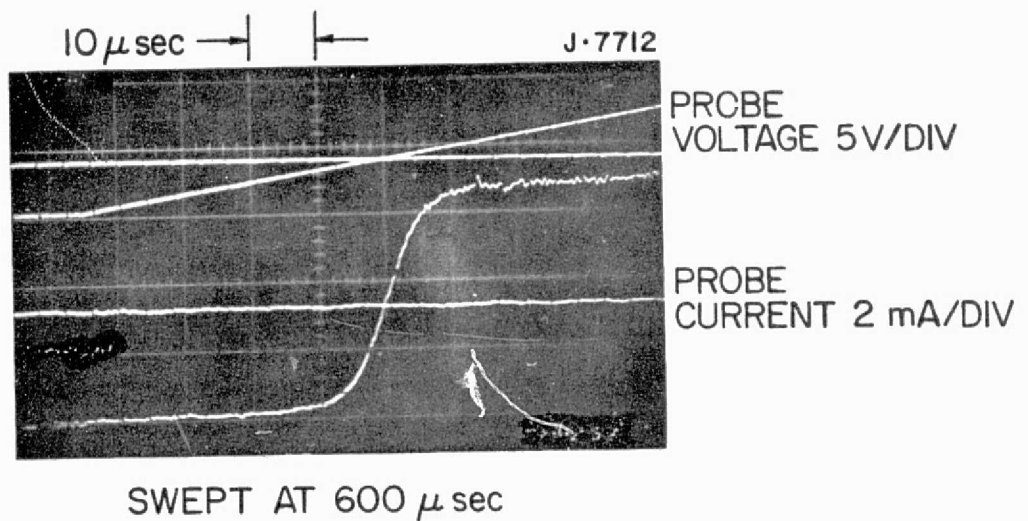

SWEPT PROBE RESPONSE

slope of the characteristic from

$$\left. \frac{dV}{dI} \right|_{V=0} = \left. \frac{dV}{dt} \right|_{V=0} / \left. \frac{dI}{dt} \right|_{V=0} \quad (4)$$

This procedure was used for all of the data reported in the next section.

### 3. Results of Probe Measurements

The experiments reported here were designed to verify that electron temperature measurements using the single shot, swept voltage technique are reliable. For all tests, the probe was mounted on the centerline, 32 cm downstream of the anode, and the arc current and mass flow were maintained at 4 kA and 12 g/sec respectively. This operating condition and probe location were chosen because previous optical depth measurements indicated a population inversion among the states of the 0.4880  $\mu$  argon ion transition for this case.

One of the principal concerns in determining a temperature by a voltage sweep technique is that the bias change will be too rapid to obtain the correct value of the temperature. Calculations show that the highest frequency associated with a bias change of the order of  $kT_e/e$  ( $8 \times 10^5 \text{ sec}^{-1}$ ) is small compared to the ion plasma frequency evaluated at the electron temperature ( $7 \times 10^8 \text{ sec}^{-1}$ ), i.e. the probe sheath is easily capable of adjusting to the changing probe bias.<sup>A-11</sup> Still, the ultimate test of the data lies in comparing the deduced temperatures over the maximum range of biasing rates.

To test the effect of frequency, the voltage sweep time and amplitude were varied from 50 to 400  $\mu\text{sec}$  and 5 to 20 volts respectively, corresponding to  $2.5 \times 10^4 < dV/dt < 8.5 \times 10^5 \text{ V/sec}$ . Over this entire range of sweep rates, the measured electron temperature was the same within 5% at a value of 2760  $^\circ\text{K}$ .

As an aside, this electron temperature measurement may help to explain the population inversion that has been indicated

by other data. The low temperature not only rules out collisional excitation from lower lying states, but also is necessary to explain the large recombination rates which result in a flux of electrons from the continuum into the bound states of AII to produce the inversion.

Further evidence that the plasma frequency response is not imposing any limitation on the acquisition of single shot temperatures is provided by the probe current-voltage characteristics in Fig. 15. These data were obtained using a voltage sweep rate of  $8.5 \times 10^4$  V/sec with a probe whose aspect ratio was 200. In this figure, the solid line represents the characteristic determined by plotting the instantaneous values of the swept probe bias and current from a single oscillogram; the superimposed data points were obtained by setting a fixed bias on the probe and measuring the probe current during the 500- $\mu$ sec quasi-steady phase of the discharge. Each data point represents the mean of several shots using the same bias. The fact that the curves are virtually identical is conclusive proof that the voltage sweep technique is reliable.

In the above experiments the probes were glow-cleaned after every firing of the arc to ensure that the electrode surfaces were not contaminated, thus producing a spurious current-voltage characteristic. In order to determine the influence of material deposited on the probes, characteristics were obtained from successive firings of the accelerator without cleaning the probes. Figures 16a, b and c show the probe current after 1, 4 and 7 discharges. Comparing Figs. 16a and b, the first effect observed is a reduction in the slope of the probe current at  $V = 0$ , which produces an incorrectly large  $(dV/dI)_{V=0}$ . Since the saturation currents aren't appreciably altered, use of this characteristic would result in an erroneously large value of electron temperature. This effect has been observed by others<sup>A-12</sup> and is apparently caused by charges in the probe contact potential due to the deposition of thin layers of for-



FIGURE 15  
AP25 · 5144

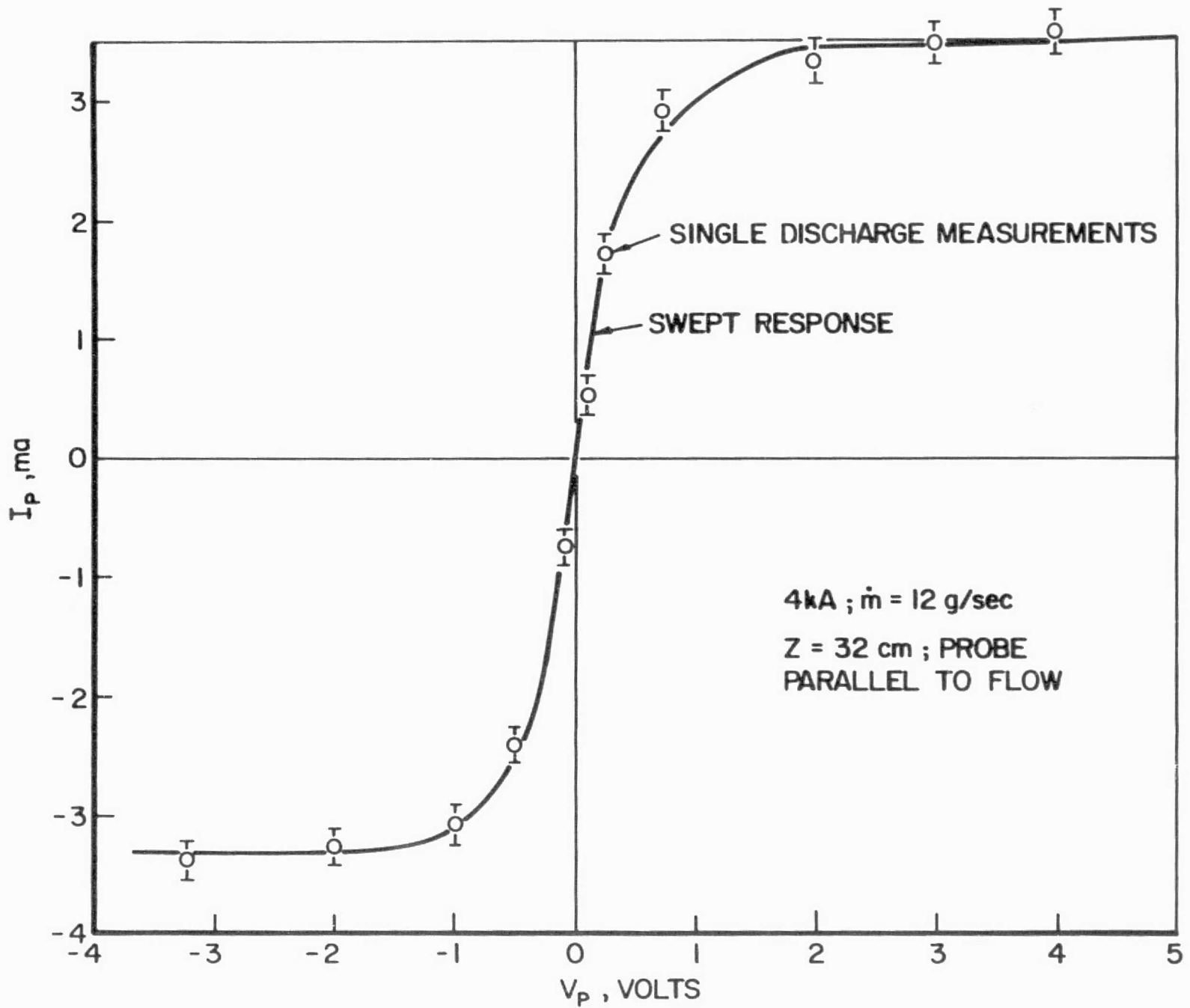

PROBE CHARACTERISTIC

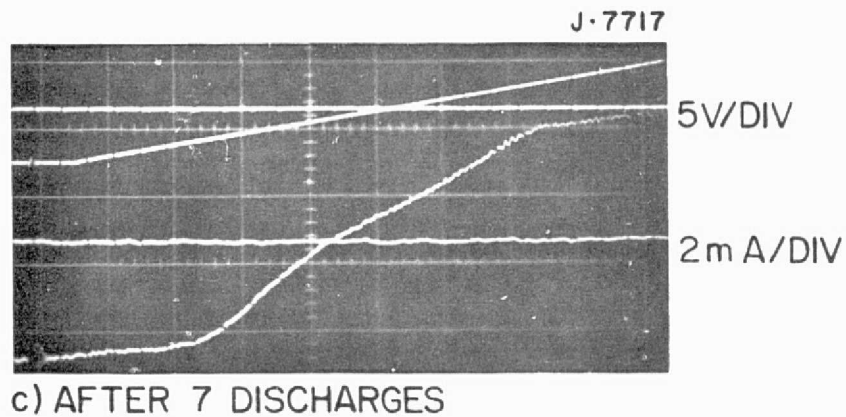
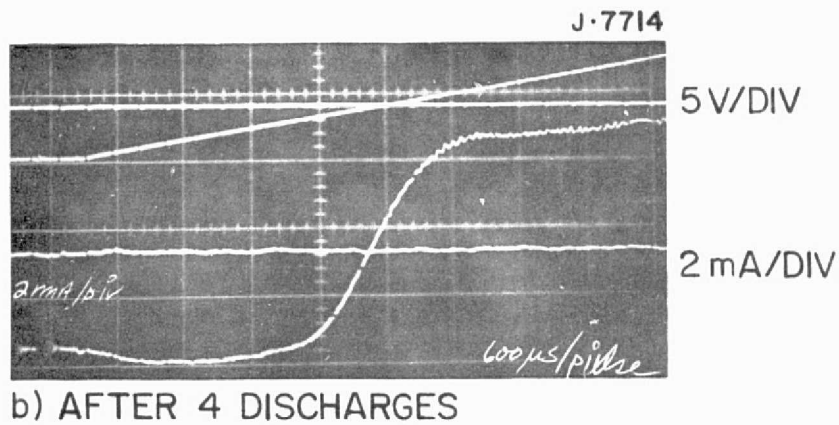
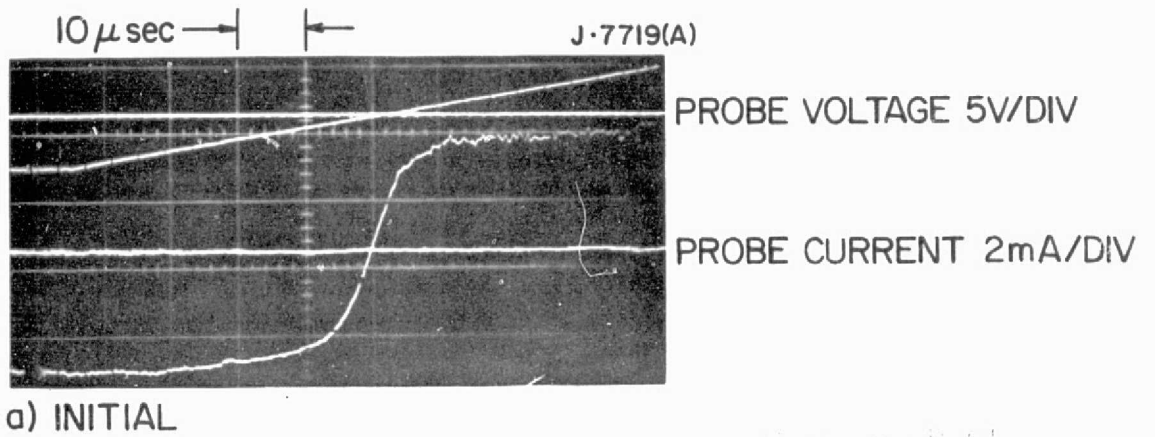

PROBE RESPONSE WITH CONTAMINATION

eign material. After many arc firings, the characteristic is considerably distorted (Fig. 16c). The hint of two saturation regions may be due to self-cleaning of the probe at higher voltages, exposing more of the electrode surface area.

In summary, the voltage sweep technique offers a rapid and reliable method for determining the current-voltage characteristic of a double probe. With this diagnostic, it is now possible to obtain spatial maps of electron temperature over a wide range of arc operation. These mappings have been initiated with the goal of a better understanding of the relaxation processes occurring in the exhaust flow of the accelerator.

## IV. HOLLOW CATHODE STUDIES (Krishnan)

In the preceding semi-annual report, a comprehensive picture of the Princeton hollow cathode program was presented.<sup>166</sup> In it were described experimental measurements of current and potential distributions in various large hollow cathodes for arc currents from 0.9 to 7 kA and argon mass flows from  $10^{-3}$  to 16 g/sec. These measurements showed that at the highest current the current distribution within the cavity is uninfluenced by changes in the cathode configuration, whereas varying the current and mass flow for a fixed cathode configuration produces significant changes in the current conduction pattern. For a given current, maximum current penetration into the cavity occurs at mass flows of approximately  $10^{-1}$  g/sec, decreasing for both higher mass flows, up to 10 g/sec, and lower mass flows, down to  $10^{-3}$  g/sec. For a fixed mass flow, the penetration monotonically increases as the current decreases. Spectroscopic measurements of AI and AII line radiation, and spectral photographs taken through a 4880 Å AII filter confirmed these attachment patterns.

In the most recent work, the current and potential distributions were measured at a still lower current of 0.25 kA for the range of argon mass flows from  $10^{-3}$  to 0.4 g/sec. When these results are compared with earlier results obtained with the same mass flows but with higher currents of 0.9 to 7 kA, a consistent picture emerges of the effects of current and mass flow on the current distribution within a large hollow cathode.

## A. Experiments

To determine first whether the maximum penetration of current into the cavity continues to increase as the current is decreased below 0.9 kA, the current distributions were measured for a current of 0.25 kA and several argon mass flows.

The current distributions were obtained by traversing a 0.3-cm-dia. magnetic field probe at a fixed radial position of 0.8 cm. Using standard passive integration techniques and the measured azimuthal symmetry of the cavity plasma, the probe directly yields the current enclosed in a circular cross section whose radius equals the probe radial position. Assuming purely radial current flow between the 0.8-cm radial position and the cavity wall ( $R = 0.95$  cm), the local slope of the enclosed current profile yields the surface current density.

Figure 17 shows a typical enclosed current profile and its associated radial current density profile for HC XII, shown for comparison at the top of the figure. The arc operating conditions for these data are a total current of 0.25 kA and a mass flow of 0.1 g/sec argon. As a check on the current density data, integration of the profile over the cavity surface gives a total current of 0.254 kA, well within the estimated 10% error bar for these data.

Figure 18 shows the surface current density profile from Fig. 17, along with several other profiles taken at various mass flows from  $5 \times 10^{-3}$  to 0.4 g/sec. The current was fixed at 0.25 kA and the cathode was again HC XII. From these distributions of surface current density, three characteristic features emerge:

1) As the argon mass flow is reduced from 0.4 g/sec to 0.1 g/sec, the peak in the surface current density moves from 0.3 cm to 1.9 cm upstream of the end of the cathode cavity.

2) At the same time, the current attachment at the surface becomes more diffuse, leading to a drop in the peak current density.

3) Further reduction in the mass flow from  $10^{-1}$  g/sec to  $5 \times 10^{-3}$  g/sec causes the peak in the current density distribution to move downstream towards the end of the cathode cavity.

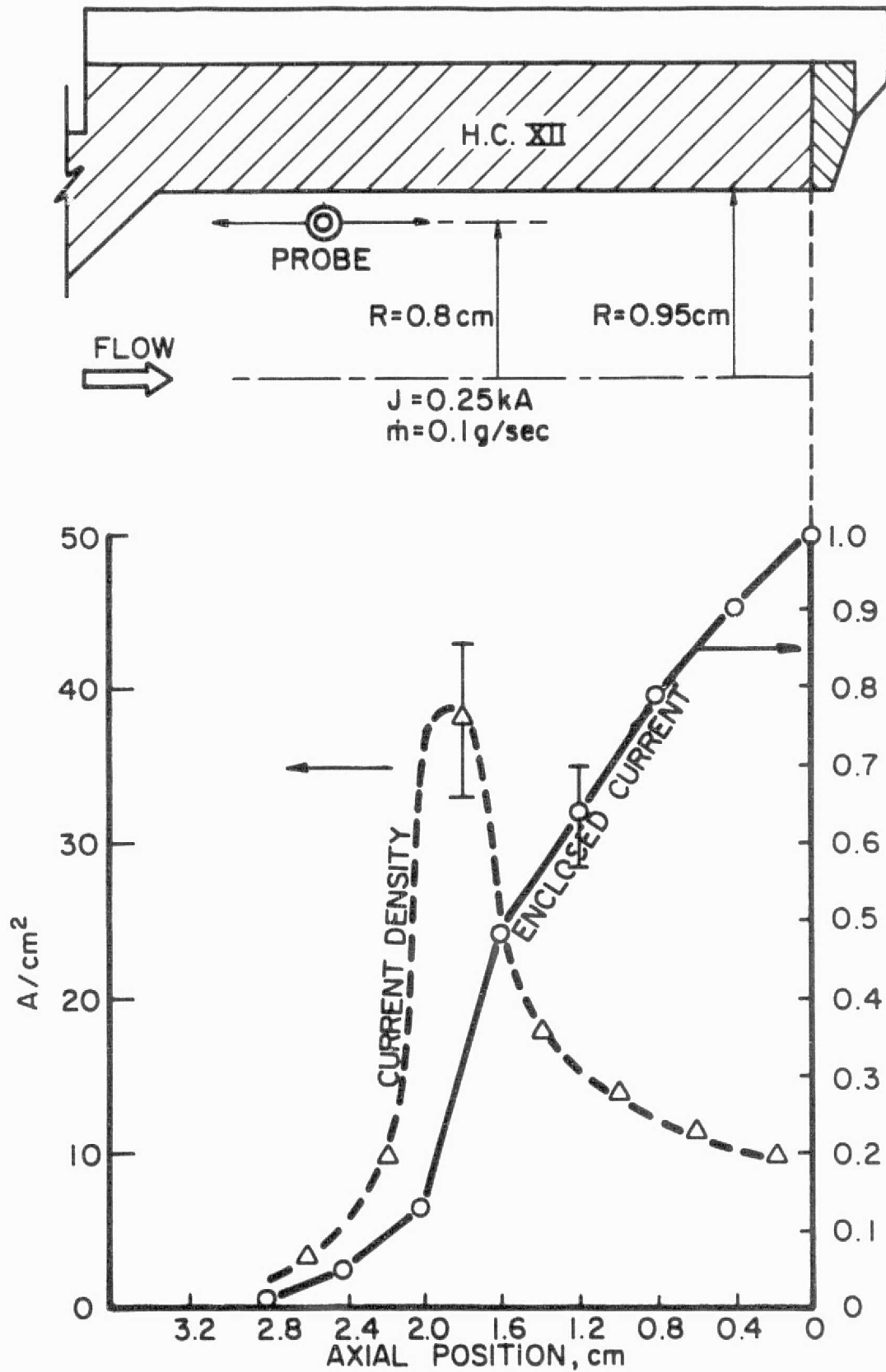

CURRENT DISTRIBUTION IN H.C. XII

FIGURE 17  
AP 25-5145

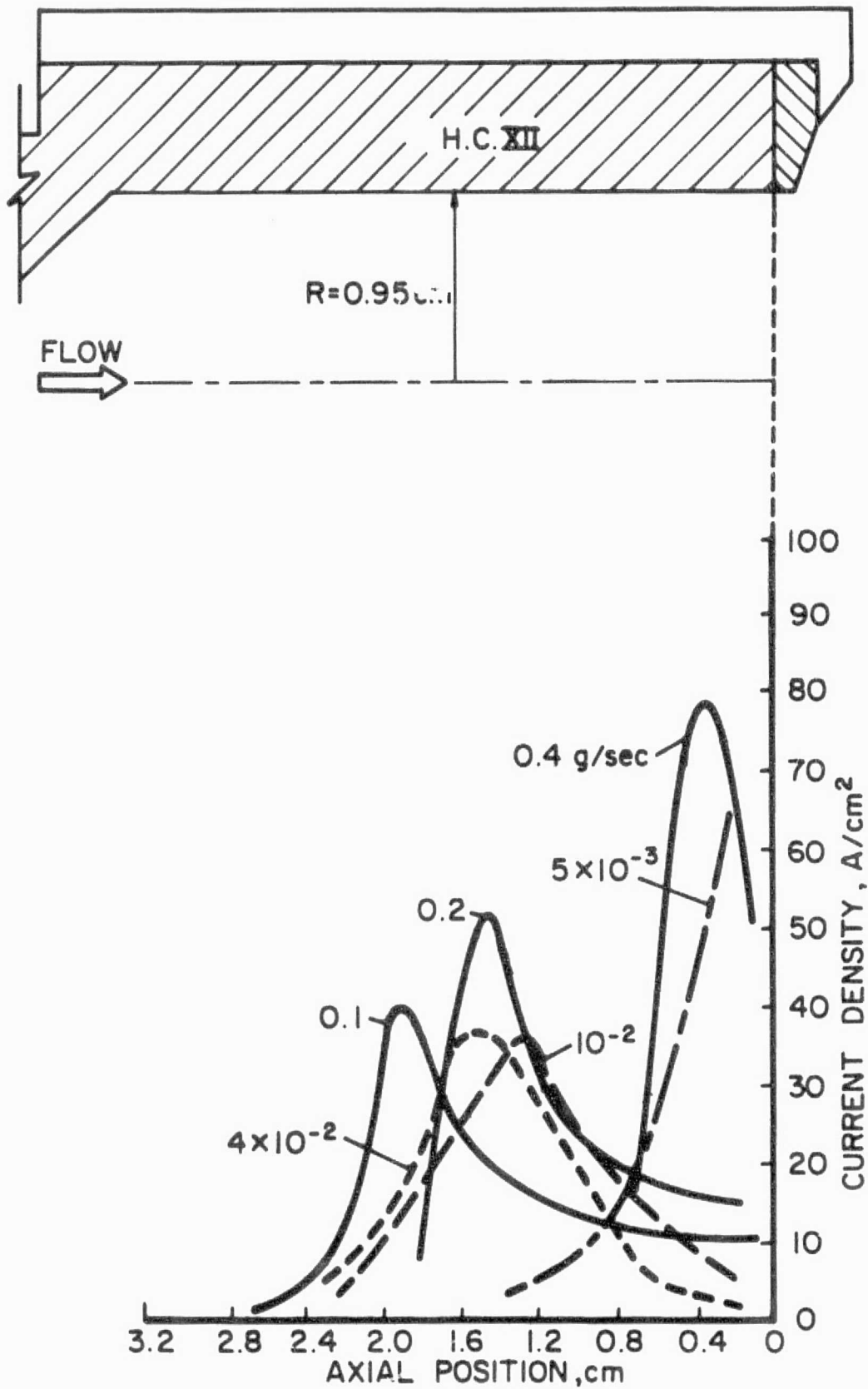

CURRENT DENSITY PROFILES, 0.25kA

FIGURE 18

To compare these data with previous measurements of enclosed current profiles at the higher currents of 0.9 and 4.7 kA, the enclosed current data at the higher currents were also reduced to yield surface current density distributions. Figure 19 shows the resulting current density profiles for a current of 0.9 kA and mass flows from  $5 \times 10^{-3}$  to 8 g/sec. Here, just as at 0.25 kA, the current density peak moves further upstream from the cavity end and the current attachment becomes more diffuse as the mass flow is reduced from 8 to  $6.6 \times 10^{-2}$  g/sec. Again, still further reduction in mass flow, from  $6.6 \times 10^{-2}$  to  $5 \times 10^{-3}$  g/sec, causes the peak in current density to move downstream towards the cavity end. However, the maximum penetration at the higher current is only 0.9 cm, compared to a maximum penetration of 1.0 cm at a current of 0.25 kA.

Figure 20 shows similar surface current density distribution for a current of 4.7 kA. At this current, unlike at the lower currents of 0.9 and 0.25 kA, the current density distribution for different mass flows are observed to be very similar. The peak current density occurs somewhere between zero and 0.2 cm from the cavity end, and in all cases, the current density falls to less than 10% of its peak value within 0.9 cm.

Figure 21 summarizes the current density measurements by graphing the active zone length, defined as the axial distance from the cavity end to the peak in current density, against the cathode mass flow, with discharge current as a parameter. The surface current density distributions are seen to be most sensitive to changes in mass flow rate at the lowest current of 0.25 kA, becoming least sensitive at the highest current of 4.7 kA. The maximum penetration of current into the hollow cathode cavity decreases as the current is increased, from one cathode diameter at 0.25 kA to approximately one-tenth of the cathode diameter at 4.7 kA.



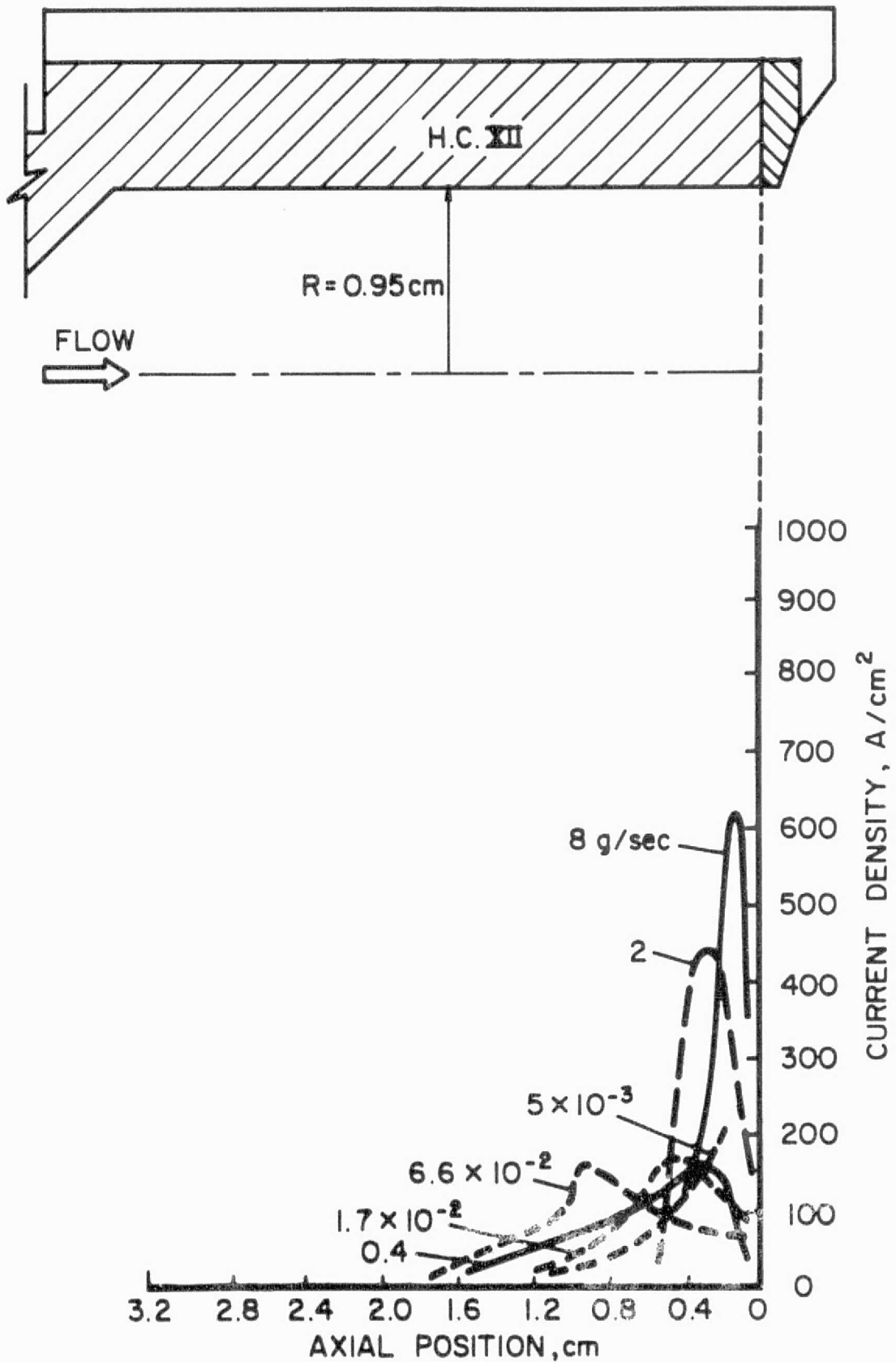

CURRENT DENSITY PROFILES, 0.9kA

FIGURE 19

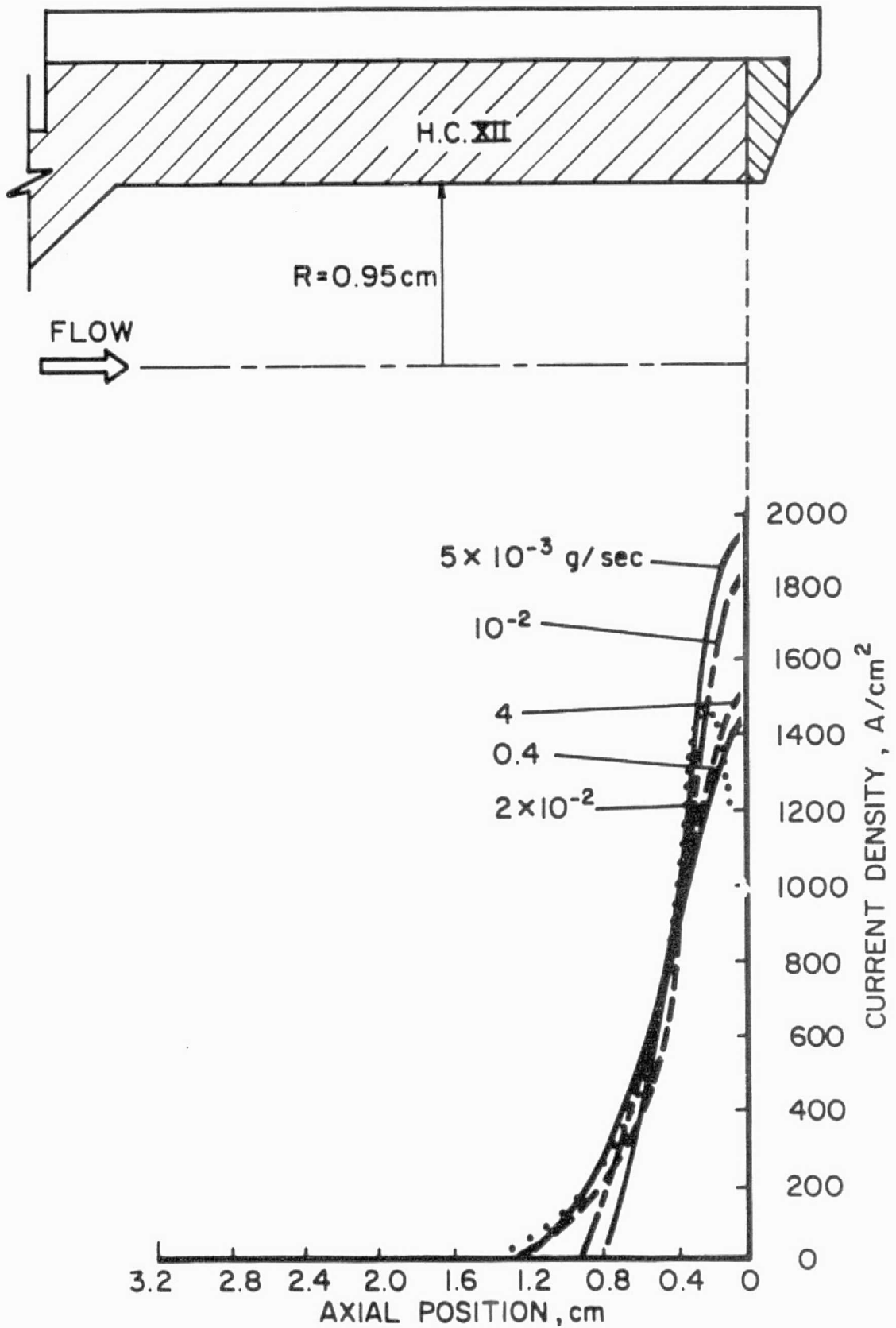

CURRENT DENSITY PROFILES, 4.7kA

FIGURE 20  
AP 25-5148

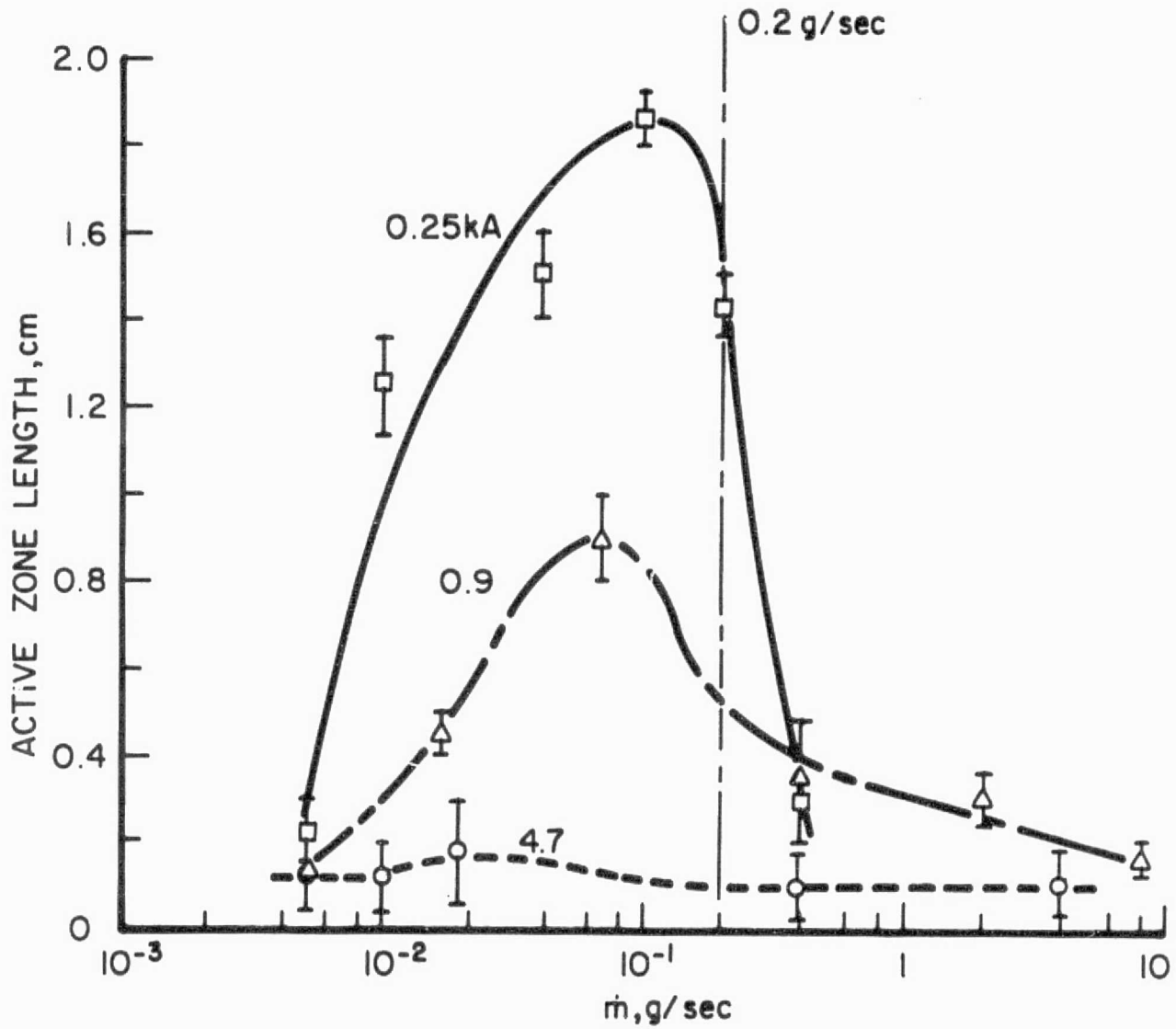

ACTIVE ZONE LENGTH

FIGURE 21  
AP 25 · 5149

It is important to note that this decrease of the current penetration into the cavity with increasing current proceeds despite the quadratically increasing  $\underline{j} \times \underline{B}$  force inside the cavity, which acts in the upstream direction opposing the gas flow.<sup>146</sup> To determine whether this dependence continues to even larger currents, the distribution of current was measured for a total current of 16.7 kA, where the electromagnetic force is known to dominate the acceleration process at these mass flows.<sup>138</sup> Figure 22 shows surface current density distributions for increasing currents of 0.25, 0.9, 4.7 and 16.7 kA, each drawn normalized to its peak value. It is observed that the trend continues to the higher currents, with the 16.7 kA current penetrating even less than the 4.7 kA current.

A more thorough understanding of the interaction between the electromagnetic forces and the gasdynamic forces could be obtained by a detailed analysis of the fluid flow processes occurring in the hollow cathode. However, such an analysis is complicated for two reasons. First, the initial cold flow field inside the hollow cathode involves oblique, curved shock waves whose patterns are difficult to compute. Second, with the initiation of the discharge, the cold gas flow field is perturbed by electron emission from the cathode wall, electromagnetic body forces, and heat addition via collisional and radiative processes.

Rather than attempt such an analysis, an experiment was performed to discriminate between the static and dynamic processes inside the hollow cathode. In this experiment, the mass flow to the hollow cathode was completely shut off, and the discharge vessel was prefilled to various static pressures of argon from  $5 \times 10^{-2}$  to 100 torr. At each ambient gas pressure, a surface current distribution was obtained for the fixed total current of 0.25 kA. These distributions are shown in Fig. 23.

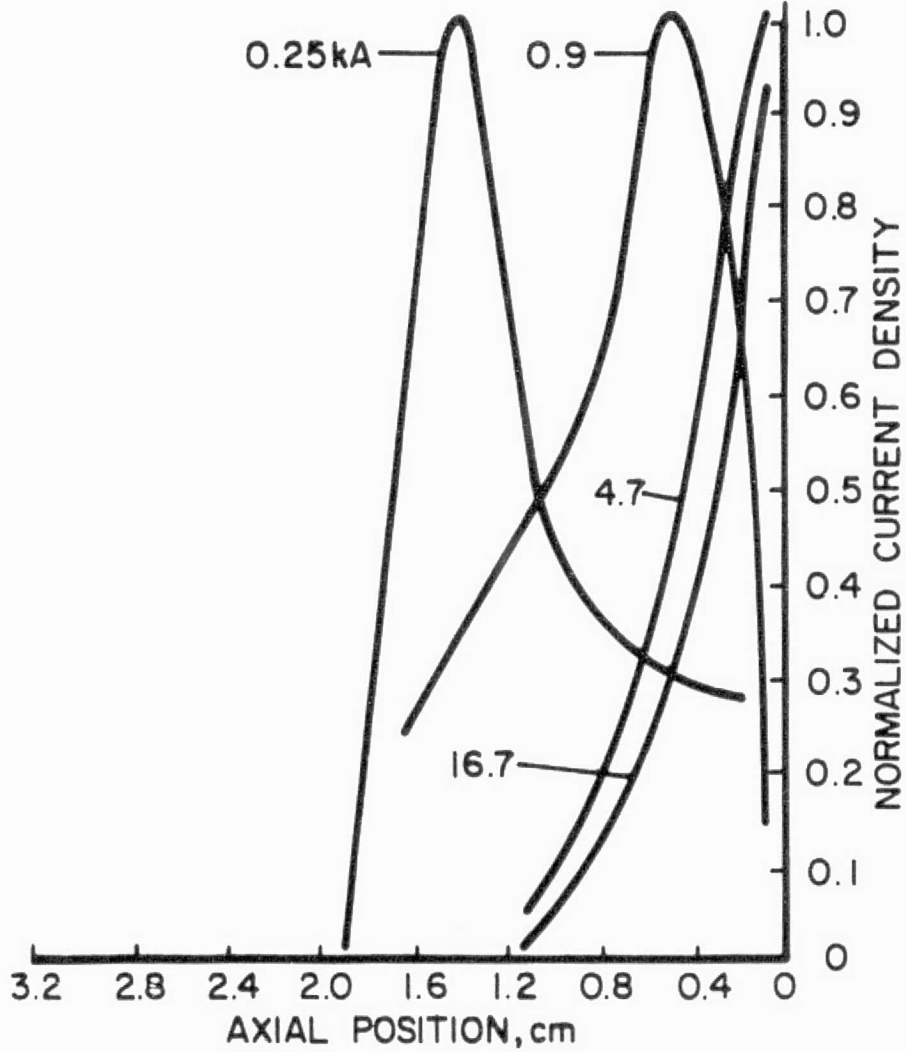
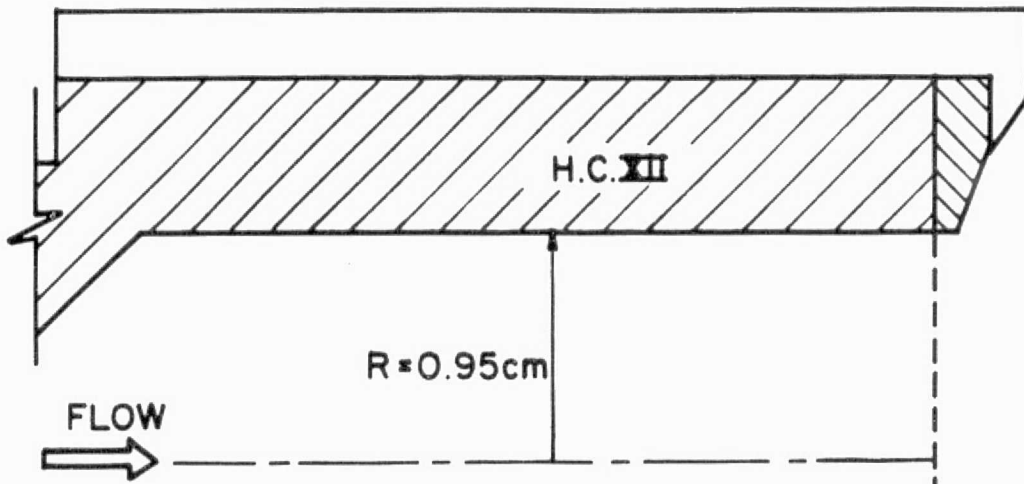

CURRENT DENSITY DISTRIBUTIONS, 0.2 g/sec

FIGURE 22

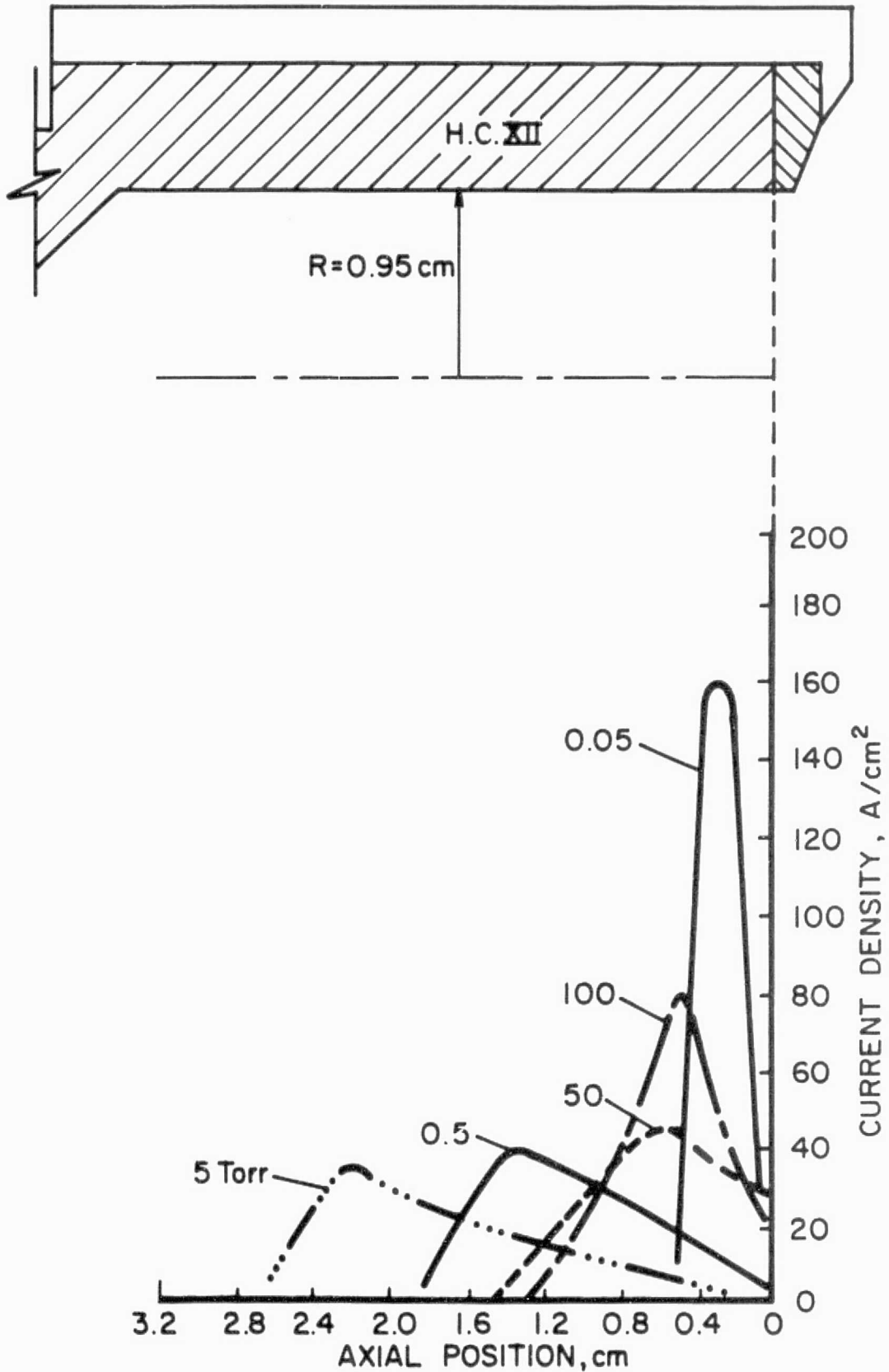

CURRENT DENSITY PROFILES, NO FLOW, 0.25 kA

Comparison of these data with Fig. 18 shows that the distributions obtained with various static prefills are closely similar to those obtained with mass flow through the hollow cathode. As the ambient pressure in the cathode is reduced from 100 torr to 5 torr, the surface current density distribution becomes more diffuse and the current density peak moves upstream to about one cathode diameter from the end of the cavity. Further reduction of the pressure from 5 torr to  $5 \times 10^{-2}$  torr causes the peak in the current distribution to move downstream towards the end of the cavity.

The effect of discharge current on the surface current density distributions at a fixed ambient pressure of 5 torr was also investigated. Figure 24 shows the surface current density distributions, normalized to the peak current density in each case, for currents of 0.25, 0.9, 4.7 and 16.7 kA, all for a fixed ambient pressure of 5 torr. It is observed that just as at a mass flow of 0.2 g/sec, Fig. 22, the effect of increased current is to move the current distributions further downstream towards the end of the cathode.

The similarity between the distributions of current for various mass flows or ambient pressures at fixed current, Figs. 18 and 23, and for various currents at fixed mass flow or ambient pressure, Figs. 22 and 24, suggests that the dynamics of the gas flow in the hollow cathode do not play a major role in establishing the surface current density patterns. Further experiments are planned to aid in discriminating between the static and dynamic components of the injected mass flow.

In all of the experiments described above, the variations of the surface current density distribution with mass flow, current and ambient pressure were determined by traversing axially a magnetic probe at a fixed radial position. In order to obtain a more comprehensive picture of the energy deposition patterns inside the hollow cathode cavity, these surface

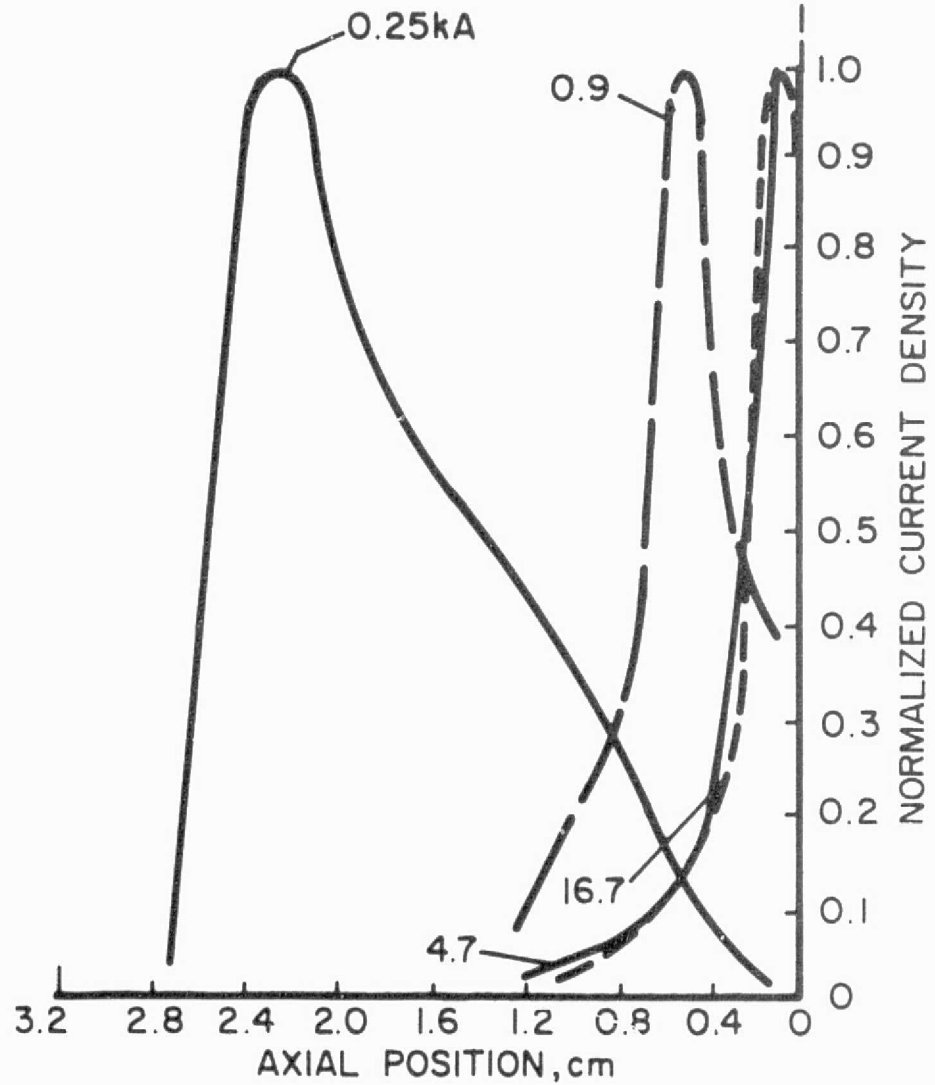
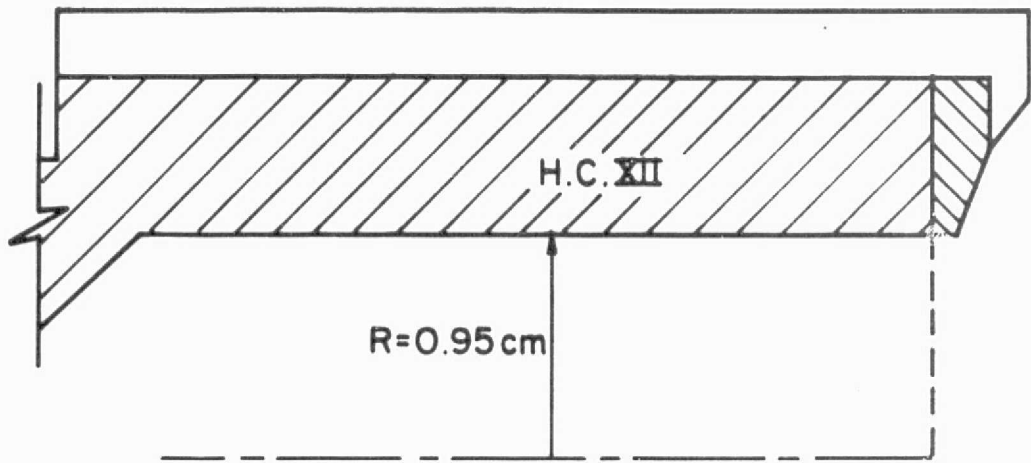

CURRENT DENSITY DISTRIBUTIONS,  $P=5\text{ Torr}$

FIGURE 24  
AP 25 · 5152



current density profiles were supplemented by magnetic field measurements throughout the cavity and by complete maps of plasma floating potential. The distributions were obtained for mass flows of 0.4 g/sec and 0.1 g/sec, both at a fixed current of 0.25 kA. Figure 18 shows that these two mass flows represent extremes in the penetration of the current into the hollow cathode cavity at 0.25 kA.

In both cases, the plasma floating potentials were measured using a single Langmuir probe consisting of an insulated 0.25-mm-diameter tungsten wire of which only the face is exposed. The probe output is connected through a 100 M $\Omega$  P-6013A voltage probe to one input of a differential amplifier at the oscilloscope. The other input is the cathode potential, measured relative to the anode ground with an identical P-6013A probe. Thus, the oscilloscope displays the floating potential relative to the cathode surface, and since electron temperature effects depress the floating potential below the true plasma potential, this differential signal is the minimum potential drop between the cathode and the probe tip.

Figure 25a shows, on a cross-sectional view of cathode HC-XII, contours of constant current and constant floating potential for a mass flow of 0.4 g/sec and a current of 0.25 kA. The lower half of the figure, Fig. 25b, shows a similar map of current and floating potential contours for the lower mass flow of 0.1 g/sec, at the same current.

For both mass flows, the equipotential lines are approximately radial in the bulk of the plasma, i.e. there is a negligible radial field in the volume of the cavity. In addition, the potentials show a weak axial electric field of less than 5 V/cm. Since the cathode itself is the zero volt equipotential in both cases, all the radial equipotentials must bend parallel to the cathode surface somewhere between the surface ( $R = 0.95$  cm) and the largest radial probe position ( $R = 0.8$  cm). If the potentials all bend within the Debye sheath separating

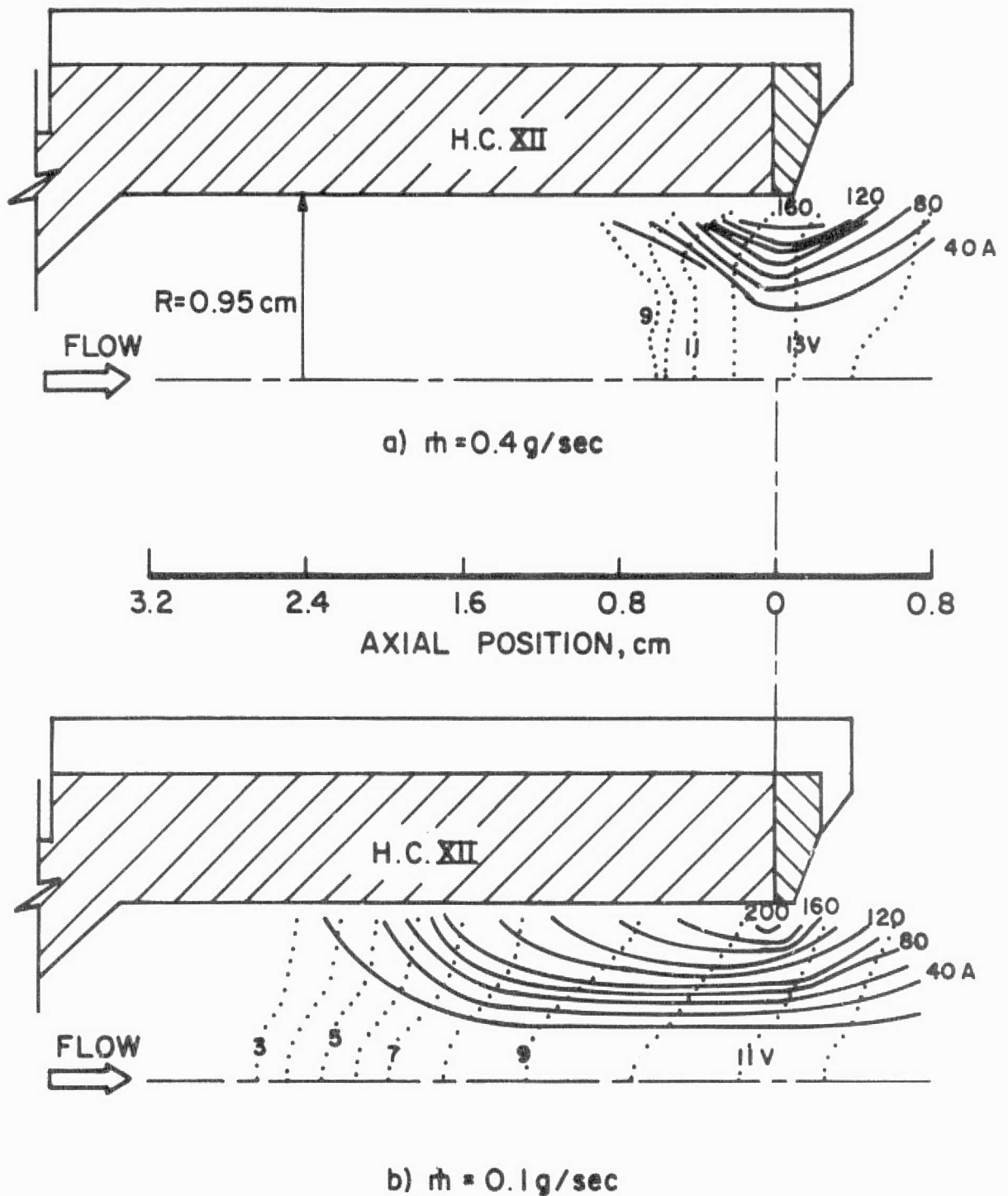

ENCLOSED CURRENT AND POTENTIAL PROFILES, 0.25 kA

FIGURE 25  
AP25-5153

the surface from the quasi neutral plasma, extremely high radial electric fields, of order  $10^7$  V/cm, would be produced at the surface of the hollow cathode.

From the intersecting grid of current and potential lines, the power density,  $\underline{j} \cdot \underline{E}$ , in any volume segment of the plasma can be easily determined. The results of this computation are graphed in Fig. 26a and b which show power density as a function of axial position inside the cavity, with radius as a parameter. For both mass flows, it is observed that the power density profile at a radius of 0.8 cm is qualitatively similar to the surface current density profile measured at this same radial position (Fig. 18). Furthermore, in both cases the power density profile retains its form well into the plasma, up to approximately half the radius. Thus, the detailed maps of current and potential inside the cathode cavity corroborate the significant difference in current penetration into the cavity inferred from surface current density measurements.

#### B. Summary

Current distributions measured for a range of mass flows at a total current of 0.25 kA display trends similar to previous measurements at 0.9 and 4.7 kA. At a fixed current, the penetration of the current into the cavity initially increases as the mass flow is decreased, but then decreases as mass flow is decreased further. The maximum penetration for a given mass flow increases as current is decreased from 16.7 to 0.25 kA, reaching approximately one cathode diameter at 0.25 kA. Floating potential maps show that the current penetration is accompanied by a weak axial electric field of less than 5 V/cm and a radial field which is negligible except near the cavity walls. Current distributions for various static prefills with no mass flow injected through the hollow cathode were found to replicate those distributions measured with only injected flows, yielding the important result that the dynamic head of the injected flow does not play an essential role in the hollow cathode emission process.

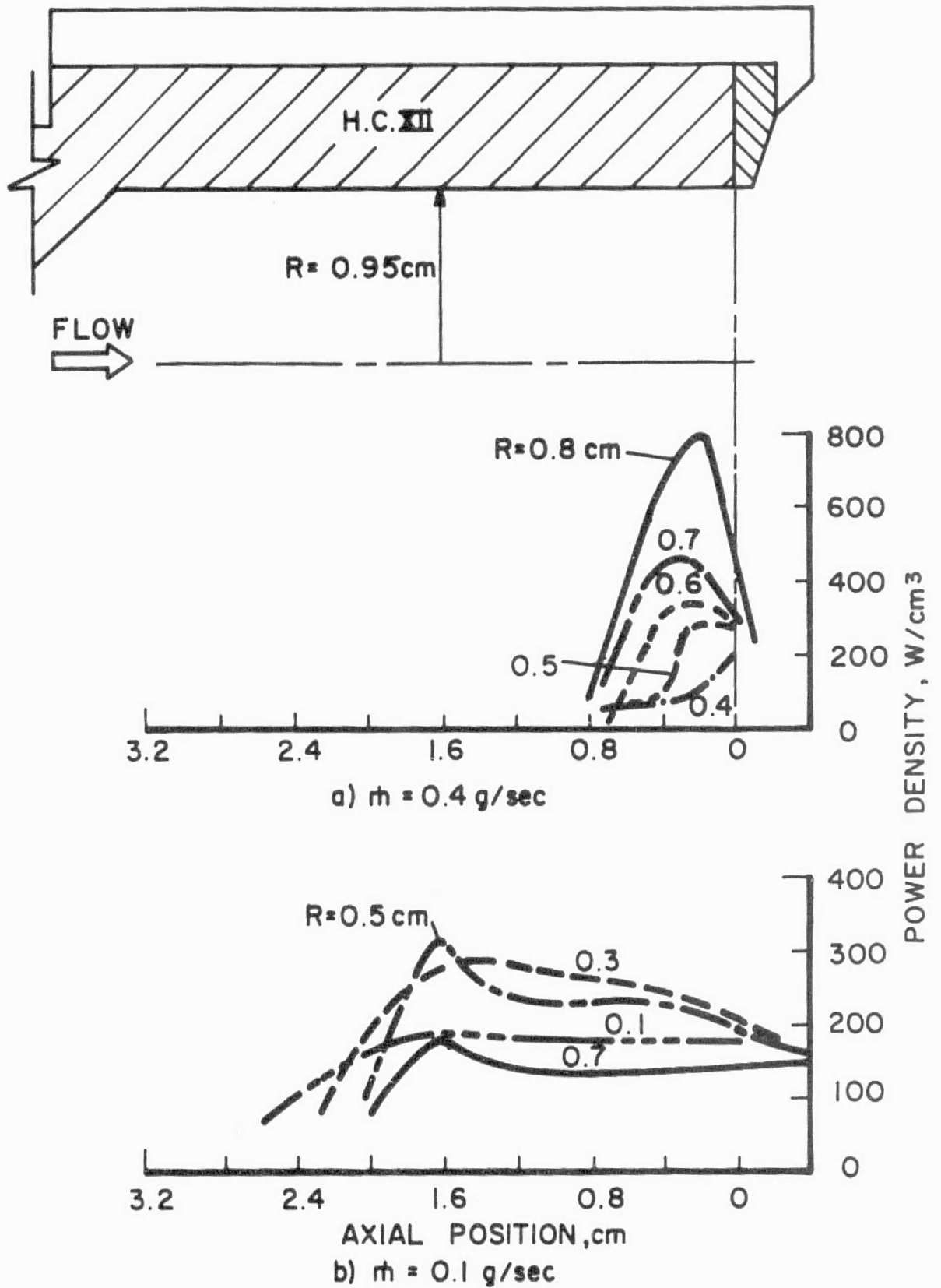

POWER DENSITY PROFILES, 0.25 kA

FIGURE 26

## PROJECT REFERENCES

- <sup>1</sup>Jahn, R. G., Bernstein, I. B. and Kunen, A. E., "Proposed Studies of the Formation and Stability of an Electromagnetic Boundary in a Pinch," Proposal for NASA Research Grant NsG-306-63, Mar. 5, 1962, Princeton Univ., Princeton, N. J.
- <sup>2</sup>Jahn, R. G. and von Jaskowsky, W. F., "Pulsed Electromagnetic Gas Acceleration," NASA NsG-306-63 progress report for the period 1 July 1962 to 31 December 1962, Aeron. Eng. Rept. No. 634, Jan. 1963, Princeton Univ., Princeton, N. J.
- <sup>3</sup>Jahn, R. G. and von Jaskowsky, W. F., "The Plasma Pinch as a Gas Accelerator," A.I.A.A. Preprint 63013, A.I.A.A. Electric Propulsion Conference, Colorado Springs, Colo., 11-13 Mar. 1963.
- <sup>4</sup>Jahn, R. G. and von Jaskowsky, W. F., "Pulsed Electromagnetic Gas Acceleration," NASA NsG-306-63 progress report for the period 1 January 1963 to 30 June 1963, Aeron. Eng. Report No. 634a, June 1963, Princeton Univ., Princeton, N. J.
- <sup>5</sup>Jahn, R. G. and von Jaskowsky, W. F., "Structure of a Large-radius Pinch Discharge," A.I.A.A. Journal, Vol. 1, No. 8, Aug. 1963, pp. 1809-1814.
- <sup>6</sup>Jahn, R. G., von Jaskowsky, W. F. and Casini, A. L., "A Gas-triggered Inverse Pinch Switch," NASA NsG-306-63, Aeron. Eng. Tech. Note No. 660, Aug. 1963, Princeton Univ., Princeton, N. J.
- <sup>7</sup>Jahn, R. G., von Jaskowsky, W. F. and Casini, A. L., "Gas triggered Inverse Pinch Switch," The Review of Scientific Instruments, Vol. 34, No. 12, Dec. 1963, pp. 1439-1440.
- <sup>8</sup>Jahn, R. G. and von Jaskowsky, W. F., "Pulsed Electromagnetic Gas Acceleration," (Paper delivered at the 4th NASA Intercenter Conference on Plasma Physics, Washington, D. C., 2-4 Dec. 1963), p. 8.
- <sup>9</sup>Jahn, R. G. and von Jaskowsky, W. F., "Pulsed Electromagnetic Gas Acceleration," NASA NsG-306-63 progress report for period 1 July 1963 to 31 December 1963, Aeron. Eng. Rept. No. 634b, Dec. 1963, Princeton Univ., Princeton, N. J.

## PROJECT REFERENCES

- <sup>10</sup>Jahn, R. G. and von Jaskowsky, W. F., "Current Distributions in Large-radius Pinch Discharges," A.I.A.A. Preprint 64-25, A.I.A.A. Aerospace Sciences Meeting, New York, N. Y., 20-22 Jan. 1964.
- <sup>11</sup>Jahn, R. G. and von Jaskowsky, W. F., "Current Distributions in Large-radius Pinch Discharges," A.I.A.A. Bulletin, Vol. 1, No. 1, Jan. 1964, p. 12.
- <sup>12</sup>Jahn, R. G. and von Jaskowsky, W. F., "Pulsed Electromagnetic Gas Acceleration," NASA NsG-306-63 renewal proposal for 15-months extension, Jan. 15, 1964, Princeton Univ., Princeton, N. J.
- <sup>13</sup>Jahn, R. G. and von Jaskowsky, W. F., "Pulsed Electromagnetic Gas Acceleration," NASA NsG-306-63 progress report for the period 1 January 1964 to 30 June 1964, Aeron. Eng. Rept. No. 634c, July 1964, Princeton Univ., Princeton, N. J.
- <sup>14</sup>Jahn, R. G., von Jaskowsky, W. F. and Casini, A. L., "Gas-triggered Pinch Discharge Switch," NASA NsG-306-63, Aerospace and Mechanical Sciences Tech. Note No. 101, July 1964, Princeton Univ., Princeton, N. J.
- <sup>15</sup>Corr, J. M., "Double Probe Studies in an 8" Pinch Discharge," M.S.E. thesis, Sept. 1964, Princeton Univ., Princeton, N. J.
- <sup>16</sup>Jahn, R. G. and von Jaskowsky, W. F., "Exhaust of a Pinched Plasma From an Axial Orifice," A.I.A.A. Bulletin, Vol. 1, No. 10, Oct. 1964, p. 570.
- <sup>17</sup>Jahn, R. G. and von Jaskowsky, W. F., "Current Distributions in Large-radius Pinch Discharges," A.I.A.A. Journal, Vol. 2, No. 10, Oct. 1964, pp. 1749-1753.
- <sup>18</sup>Jahn, R. G., von Jaskowsky, W. F. and Casini, A. L., "Gas-triggered Pinch Discharge Switch", The Review of Scientific Instruments, Vol. 36, No. 1, Jan. 1964, pp. 101-102.
- <sup>19</sup>Jahn, R. G. and von Jaskowsky, W. F., "Exhaust of a Pinched Plasma from an Axial Orifice," A.I.A.A. Paper 65-92, A.I.A.A. 2nd Aerospace Sciences Meeting, New York, N. Y., 25-27 Jan. 1964.

## PROJECT REFERENCES

- 20 Jahn, R. G. and von Jaskowsky, W. F., "Pulsed Electromagnetic Gas Acceleration," NASA NsG-306-63 progress report for the period 1 July 1964 to 31 December 1964, Aerospace and Mechanical Sciences Rept. No. 634d, Jan. 1965, Princeton Univ., Princeton, N. J.
- 21 Wright, E. S., "The Design and Development of Rogowski Coil Probes for Measurement of Current Density Distribution in a Plasma Pinch," M.S.E. thesis, May 1965, Princeton Univ., Princeton, N. J.
- 22 Jahn, R. G. and von Jaskowsky, W. F., "Pulsed Electromagnetic Gas Acceleration," NASA NsG-306-63 renewal proposal for 12-months extension, June 7, 1964, Princeton Univ., Princeton, N. J.
- 23 Jahn, R. G. and Black, N. A., "On the Dynamic Efficiency of Pulsed Plasma Accelerators," A.I.A.A. Journal, Vol. 3, No. 6, June 1965, pp. 1209-1210.
- 24 Black, N. A., "Linear Pinch Driven by a High-current Pulse-forming Network," A.I.A.A. Bulletin, Vol. 2, No. 6, June 1965, p. 309.
- 25 Wright, E. S. and Jahn, R. G., "The Design and Development of Rogowski Coil Probes for Measurement of Current Density Distribution in a Plasma Pinch," NASA NsG-306-63, Aerospace and Mechanical Sciences Rept. No. 740, June 1965, Princeton Univ., Princeton, N. J.
- 26 Rowell, G. A., "Cylindrical Shock Model of the Plasma Pinch," M.S.E. thesis, July 1965, Princeton Univ., Princeton, N. J.
- 27 Black, N. A., "Linear Pinch Driven by a High-current Pulse-forming Network," A.I.A.A. Paper 65-336, A.I.A.A. 2nd Annual Meeting, San Francisco, Calif., 26-29 July 1965.
- 28 Jahn, R. G. and von Jaskowsky, W. F., "Pulsed Electromagnetic Gas Acceleration," NASA NsG-306-63 progress report for the period 1 January 1965 to 30 June 1965, Aerospace and Mechanical Sciences Rept. No. 634e, July, 1965, Princeton Univ., Princeton, N. J.
- 29 Jahn, R. G. and Ducati, A. C., "Design and Development of a Thermo-Ionic Electric Thrustor," SQS 085-968 Interim Report, NASA Contract NASw-968, Aug. 1965, Giannini Scientific Corp., Santa Ana, Calif.

## PROJECT REFERENCES

- <sup>30</sup>Jahn, R. G., von Jaskowsky, W. F. and Burton, R. L., "Ejection of a Pinched Plasma From an Axial Orifice," A.I.A.A. Journal, Vol. 3, No. 10, Oct. 1965, pp. 1862-1866.
- <sup>31</sup>Jahn, R. G. and Wright, E. S., "Miniature Rogowski Coil Probes for Direct Measurement of Current Density Distribution in Transient Plasmas," The Review of Scientific Instruments, Vol. 36, No. 12, Dec. 1965, pp. 1891-1892.
- <sup>32</sup>Jahn, R. G. and von Jaskowsky, W. F., "Pulsed Electromagnetic Gas Acceleration," NASA NsG-306-63 progress report for the period 1 July 1965 to 31 December 1965, Aerospace and Mechanical Sciences Rept. No. 634f, Jan. 1966, Princeton Univ., Princeton, N. J.
- <sup>33</sup>Burton, R. L. and Jahn, R. G., "Electric and Magnetic Field Distributions in a Propagating Current Sheet," A.I.A.A. Bulletin, Vol. 3, No. 1, Jan. 1966, p. 35.
- <sup>34</sup>Rowell, G. A., Jahn, R. G. and von Jaskowsky, W. F., "Cylindrical Shock Model of the Plasma Pinch," NASA NsG-306-63, Aerospace and Mechanical Sciences Rept. No. 742, Feb. 1966, Princeton Univ., Princeton, N. J.
- <sup>35</sup>Burton, R. L. and Jahn, R. G., "Electric and Magnetic Field Distributions in a Propagating Current Sheet," A.I.A.A. Paper 66-200, A.I.A.A. 5th Electric Propulsion Conference, San Diego, Calif., 7-9 Mar. 1966.
- <sup>36</sup>Black, N. A., "Pulse-forming Networks for Propulsion Research," Proceedings of the 7th Symposium on Engineering Aspects of Magnetohydrodynamics, Princeton Univ., Princeton, N. J., Mar. 30-April 1, 1966, pp. 10-11.
- <sup>37</sup>Jahn, R. G., "Electromagnetic Propulsion," Astronautics and Aeronautics, Vol. 4, No. 2, February, 1966, pp. 73-75.
- <sup>38</sup>Black, N. A., "Dynamics of a Pinch Discharge Driven by a High-current Pulse-forming Network," Ph.D. thesis, May 1966, Princeton Univ., Princeton, N. J.
- <sup>39</sup>Black, N. A. and Jahn, R. G., "Dynamics of a Pinch Discharge Driven by a High-current Pulse-forming Network," NASA NsG-306-63, Aerospace and Mechanical Sciences Rept. No. 778, May 1966, Princeton Univ., Princeton, N. J.



## PROJECT REFERENCES

- <sup>40</sup>Jahn, R. G., "Pulsed Plasma Propulsion," Proceedings of the 5th NASA Intercenter and Contractors Conference on Plasma Physics, Washington, D. C., 24-26 May 1966, pt. V, pp. 75-81.
- <sup>41</sup>Jahn, R. G. and von Jaskowsky, W. F., "Pulsed Electromagnetic Gas Acceleration," NASA NsG-306-63 renewal proposal for 24-months extension, May 25, 1966, Princeton Univ., Princeton, N. J.
- <sup>42</sup>Ducati, A. C., Jahn, R. G., Muehlberger, E. and Treat, R. P., "Design and Development of a Thermo-Ionic Electric Thruster," FR-056-968 Final Report, NASA CR-54703, May 1966, Giannini Scientific Corp., Santa Ana, Calif.
- <sup>43</sup>Jahn, R. G. and Clark, K. E., "A Large Dielectric Vacuum Facility," A.I.A.A. Journal, Vol. 4, No. 6, June 1966, p. 1135.
- <sup>44</sup>John, R. R., Bennett, S. and Jahn, R. G., "Current Status of a Plasma Propulsion," A.I.A.A. Bulletin, Vol. 3, No. 5, May 1966, p. 264.
- <sup>45</sup>John, R. R., Bennett, S. and Jahn, R. G., "Current Status of a Plasma Propulsion," A.I.A.A. Paper 56-565, A.I.A.A. 2nd Propulsion Joint Specialist Conference, Colorado Springs, Colo., 13-17 June 1966.
- <sup>46</sup>Jahn, R. G. and von Jaskowsky, W. F., "Pulsed Electromagnetic Gas Acceleration," NASA NsG-306-63 progress report for the period 1 January 1966 to 30 June 1966, Aerospace and Mechanical Sciences Rept. No. 634g, July 1966, Princeton Univ., Princeton, N. J.
- <sup>47</sup>Burton, R. L., "Structure of the Current Sheet in a Pinch Discharge," Ph.D. thesis, Sept. 1966, Princeton Univ., Princeton, N. J.
- <sup>48</sup>Burton, R. L. and Jahn, R. G., "Structure of the Current Sheet in a Pinch Discharge," NASA NsG-306-63, Aerospace and Mechanical Sciences Rept. No. 783, Sept. 1966, Princeton Univ., Princeton, N. J.
- <sup>49</sup>Jahn, R. G. and von Jaskowsky, W. F., "Pulsed Electromagnetic Gas Acceleration," NASA NsG-306-63 progress report for the period 1 July 1966 to 31 December 1966, Aerospace and Mechanical Sciences Rept. No. 634h, Jan. 1967, Princeton Univ., Princeton, N. J.

## PROJECT REFERENCES

- 50 Burton, R. L. and Jahn, R. G., "Structure of the Current Sheet in a Pinch Discharge," Bulletin of the American Physical Society, Vol. 12, Ser. II, Paper L1, May 1967, p. 848.
- 51 Jahn, R. G., "Plasma Propulsion for Deep Space Flight," Bulletin of the American Physical Society, Vol. 12, Ser. II, Paper BC-1, May 1967, p. 646.
- 52 Ellis, W. R., Jr., "An Investigation of Current Sheet Structure in a Cylindrical Z-Pinch," Ph.D. thesis, July 1967, Princeton Univ., Princeton, N. J.
- 53 Ellis, W. R., Jr. and Jahn, R. G., "An Investigation of Current Sheet Structure in a Cylindrical Z-Pinch," NASA NsG-306-63, Aerospace and Mechanical Sciences Rept. No. 805, July 1967, Princeton Univ., Princeton, N. J.
- 54 Jahn, R. G. and von Jaskowsky, W. F., "Pulsed Electromagnetic Gas Acceleration," NASA NsG-306-63 progress report for the period 1 January 1967 to 30 June 1967, Aerospace and Mechanical Sciences Rept. No. 634i, July 1967, Princeton Univ., Princeton, N. J.
- 55 Clark, K. E. and Jahn, R. G., "The Magnetoplasma-dynamic Arc," Astronautica Acta, Vol. 13, No. 4, 1967, pp. 315-325.
- 56 Jahn, R. G., "The MPD Arc," NASA Contract NASw-1513, Aug. 1967, Giannini Scientific Corp., Santa Ana, Calif.
- 57 Eckbreth, A. C., Clark, K. E. and Jahn, R. G., "Current Pattern Stabilization in Pulsed Plasma Accelerators," A.I.A.A. Bulletin, Vol. 4, No. 9, Sept. 1967, p. 433.
- 58 Clark, K. E., Eckbreth, A. C. and Jahn, R. G., "Current Pattern Stabilization in Pulsed Plasma Accelerators," A.I.A.A. Paper 67-656, A.I.A.A. Electric Propulsion and Plasmadynamics Conference, Colorado Springs, Colo., 11-13 Sept. 1967.
- 59 Jahn, R. G. and von Jaskowsky, W. F., "Pulsed Electromagnetic Gas Acceleration," NASA NsG-306-63 progress report for the period 1 July 1967 to 31 December 1967, Aerospace and Mechanical Sciences Rept. No. 634j, Jan. 1968, Princeton Univ., Princeton, N. J.

## PROJECT REFERENCES

- <sup>60</sup> Ducati, A. C., Jahn, R. G., Muehlberger, E. and Treat, R. P., "Exploratory Electromagnetic Thruster Research," TR 117-1513 Annual Report, NASA CR 62047, Feb. 1968, Giannini Scientific Corp., Santa Ana, Calif.
- <sup>61</sup> Jahn, R. G., PHYSICS OF ELECTRIC PROPULSION, McGraw-Hill Book Company, New York, 1968.
- <sup>62</sup> Burton, R. L. and Jahn, R. G., "Acceleration of Plasma by a Propagating Current Sheet," The Physics of Fluids, Vol. 11, No. 6, June 1968, pp. 1231-1237.
- <sup>63</sup> Jahn, R. G. and von Jaskowsky, W. F., "Pulsed Electromagnetic Gas Acceleration," NASA NGR 31-001-005 step-funding renewal proposal for the period 1 October 1968 to 30 September 1971, June 1, 1968, Princeton Univ., Princeton, N. J.
- <sup>64</sup> Jahn, R. G. and von Jaskowsky, W. F., "Pulsed Electromagnetic Gas Acceleration," NASA Nsg-306/31-001-005 progress report for the period 1 January 1968 to 30 June 1968, Aerospace and Mechanical Sciences Rept. No. 634k, July 1968, Princeton Univ., Princeton, N. J.
- <sup>65</sup> Wilbur, P. J., "Energy Transfer from a Pulse Network to a Propagating Current Sheet," Ph.D. thesis, Sept. 1968, Princeton Univ., Princeton, N. J.
- <sup>66</sup> Wilbur, P. J. and Jahn, R. G., "Energy Transfer from a Pulse Network to a Propagating Current Sheet," NASA NGR 31-001-005, Aerospace and Mechanical Sciences Rept. No. 846, Sept. 1968, Princeton Univ., Princeton, N. J.
- <sup>67</sup> Ducati, A. C., Jahn, R. G., Muehlberger, E. and Treat, R. P., "Exploratory Electromagnetic Thruster Research, Phase II," 2SS108-1513 Interim Report, NASA Contract NASw-1513, Oct. 1968, Giannini Scientific Corp., Santa Ana, Calif.
- <sup>68</sup> Eckbreth, A. C., Clark, K. E. and Jahn, R. G., "Current Pattern Stabilization in Pulsed Plasma Accelerators," A.I.A.A. Journal, Vol. 6, No. 11, Nov. 1968, pp. 2125-2132.

## PROJECT REFERENCES

- <sup>69</sup> Eckbreth, A. C., "Current Pattern and Gas Flow Stabilization in Pulsed Plasma Accelerators," Ph.D. thesis, Dec. 1968, Princeton Univ., Princeton, N. J.
- <sup>70</sup> Eckbreth, A. C. and Jahn, R. G., "Current Pattern and Gas Flow Stabilization in Pulsed Plasma Accelerators," NASA NGL 31-001-005, Aerospace and Mechanical Sciences Rept. No. 857, Dec. 1968, Princeton Univ., Princeton, N. J.
- <sup>71</sup> York, T. M., "Pressure Distribution in the Structure of a Propagating Current Sheet," Ph.D. thesis, Dec. 1968, Princeton Univ., Princeton, N. J.
- <sup>72</sup> York, T. M. and Jahn, R. G., "Pressure Distribution in the Structure of a Propagating Current Sheet," NASA NGL 31-001-005, Aerospace and Mechanical Sciences Rept. No. 853, Dec. 1968, Princeton Univ., Princeton, N. J.
- <sup>73</sup> Eckbreth, A. C. and Jahn, R. G., "Current Pattern and Gas Flow Stabilization in Pulsed Plasma Accelerators," A.I.A.A. Bulletin, Vol. 5, No. 12, Dec. 1968, p. 730.
- <sup>74</sup> Wilbur, P. J. and Jahn, R. G., "Energy Transfer From a Pulse Network to a Propagating Current Sheet," A.I.A.A. Bulletin, Vol. 5, No. 12, Dec. 1968, p. 730.
- <sup>75</sup> Ellis, W. R. and Jahn, R. G., "Ion Density and Current Distributions in a Propagating Current Sheet, Determined by Microwave Reflection Technique," Rept. No. CLM-P-187, Dec. 1968, Culham Laboratory, Abingdon, Berkshire, Great Britain.
- <sup>76</sup> Jahn, R. G. and von Jaskowsky, W. F., "Pulsed Electromagnetic Gas Acceleration," NASA NGL 31-001-005 progress report for the period 1 July 1968 to 31 December 1968, Aerospace and Mechanical Sciences Rept. No. 634, Jan. 1969, Princeton Univ., Princeton, N. J.
- <sup>77</sup> Eckbreth, A. C. and Jahn, R. G., "Current Pattern and Gas Flow Stabilization in Pulsed Plasma Accelerators," A.I.A.A. Paper 69-112, A.I.A.A. 7th Aerospace Sciences Meeting, New York, N. Y., 20-22 Jan. 1969.

## PROJECT REFERENCES

- <sup>78</sup>Wilbur, P. J. and Jahn, R. G., "Energy Transfer From a Pulse Network to a Propagating Current Sheet," A.I.A.A. Paper 69-113, A.I.A.A. 7th Aerospace Sciences Meeting, New York, N. Y., 20-22 Jan. 1969.
- <sup>79</sup>Ellis, W. R. and Jahn, R. G., "Ion Density and Current Distributions in a Propagating Current Sheet, Determined by Microwave Reflection Technique," Journal of Plasma Physics, Vol. 3, Pt. 2, 1969, pp. 189-213.
- <sup>80</sup>York, T. M. and Jahn, R. G., "Pressure Distribution in the Structure of a Propagating Current Sheet," A.I.A.A. Bulletin, Vol. 6, No. 2, Feb. 1969, p. 75.
- <sup>81</sup>Clark, K. E. and Jahn, R. G., "Quasi-steady Plasma Acceleration," A.I.A.A. Bulletin, Vol. 6, No. 2, Feb. 1969, p. 75.
- <sup>82</sup>York, T. M. and Jahn, R. G., "Pressure Distribution in the Structure of a Propagating Current Sheet," A.I.A.A. Paper 69-264, A.I.A.A. 7th Electric Propulsion Conference, Williamsburg, Va., 3-5 Mar. 1969.
- <sup>83</sup>Clark, K. E. and Jahn, R. G., "Quasi-steady Plasma Acceleration," A.I.A.A. Paper 69-267, A.I.A.A. 7th Electric Propulsion Conference, Williamsburg, Va., 3-5 Mar. 1969.
- <sup>84</sup>Jahn, R. G. and Mickelsen, W. R., "Electric Propulsion Notebook," A.I.A.A. Professional Study Series, Williamsburg, Va., 1-2 Mar. 1969.
- <sup>85</sup>Boyle, M. J., "Plasma Velocity Measurements with Electric Probes," B.S.E. thesis, April 1969, Princeton Univ., Princeton, N. J.
- <sup>86</sup>Clark, K. E., "Quasi-steady Plasma Acceleration," Ph.D. thesis, May 1969, Princeton Univ., Princeton, N. J.
- <sup>87</sup>Clark, K. E. and Jahn, R. G., "Quasi-steady Plasma Acceleration," NASA NGL 31-001-005, Aerospace and Mechanical Sciences Rept. No. 859, May 1969, Princeton Univ., Princeton, N. J.

## PROJECT REFERENCES

- <sup>88</sup>Boyle, M. J., "Plasma Velocity Measurements with Electric Probes," Paper No. 4 (Paper presented at the North-eastern Regional Student Conference, Princeton Univ., Princeton, N. J., 9-10 May 1969).
- <sup>89</sup>Mickelsen, W. R. and Jahn, R. G., "Status of Electric Propulsion," A.I.A.A. Bulletin, Vol. 6, No. 6, June 1969, p. 257.
- <sup>90</sup>Mickelsen, W. R. and Jahn, R. G., "Status of Electric Propulsion," A.I.A.A. Paper 69-497, A.I.A.A. 5th Propulsion Joint Specialist Conference, U. S. Air Force Academy, Colo., 9-13 June 1969.
- <sup>91</sup>Ducati, A. C. and Jahn, R. G., "Electron Beam from a Magnetoplasma-dynamic Arc," The Physics of Fluids, Vol. 12, No. 6, June 1969, pp. 1177-1181.
- <sup>92</sup>Jahn, R. G. and von Jaskowsky, W. F., "Pulsed Electromagnetic Gas Acceleration," NASA NGL 31-001-005 progress report for the period 1 January 1969 to 30 June 1969, Aerospace and Mechanical Sciences Rept. No. 634m, July 1969, Princeton Univ., Princeton, N. J.
- <sup>93</sup>Jahn, R. G. and von Jaskowsky, W. F., "Pulsed Electromagnetic Gas Acceleration," NASA NGR 31-001-005 step-funding renewal proposal for the period 1 October 1969 to 30 September 1970, July 1, 1969, Princeton Univ., Princeton, N. J.
- <sup>94</sup>Jahn, R. G., Clark, K. E., Oberth, R. C. and Turchi, P. J., "Acceleration Patterns in Quasi-steady MPD Arcs," A.I.A.A. Bulletin, Vol. 6, No. 12, Dec. 1969, p. 701.
- <sup>95</sup>Ducati, A. C. and Jahn, R. G., "Repetitively Pulsed, Quasi-steady Vacuum MPD Arc," A.I.A.A. Bulletin, Vol. 6, No. 12, Dec. 1969, p. 701.
- <sup>96</sup>Jahn, R. G., von Jaskowsky, W. F. and Clark, K. E., "Pulsed Electromagnetic Gas Acceleration: Acceleration Processes in Quasi-steady Arcs," (Paper delivered at the 6th NASA Intercenter and Contractors Conference on Plasma Physics, NASA Langley Research Center, Hampton, Va., 8-10 Dec. 1969), pp. 8-15.

## PROJECT REFERENCES

- 97 Jahn, R. G., von Jaskowsky, W. F. and Clark, K. E., "Pulsed Electromagnetic Gas Acceleration," NASA NGL 31-001-005 progress report for the period 1 July 1969 to 31 December 1969, Aerospace and Mechanical Sciences Rept. No. 634n, Jan. 1970, Princeton Univ., Princeton, N. J.
- 98 Eckbreth, A. C. and Jahn, R. G., "Current Pattern and Gas Flow Stabilization in Pulsed Plasma Accelerators," A.I.A.A. Journal, Vol. 8, No. 1, Jan. 1970, pp. 138-143.
- 99 Jahn, R. G., Clark, K. E., Oberth, R. C. and Turchi, P. J., "Acceleration Patterns in Quasi-steady MPD Arcs," A.I.A.A. Paper 70-165, A.I.A.A. 8th Aerospace Sciences Meeting, New York, N. Y., 19-21 Jan. 1970.
- 100 Ducati, A. C. and Jahn, R. G., "Repetitively Pulsed, Quasi-steady Vacuum MPD Arc," A.I.A.A. Paper 70-167, A.I.A.A. 8th Aerospace Sciences Meeting, New York, N. Y., 19-21 Jan. 1970.
- 101 Wilbur, P. J. and Jahn, R. G., "Energy Transfer from a Pulse Network to a Propagating Current Sheet," A.I.A.A. Journal, Vol. 8, No. 1, Jan. 1970, pp. 144-149.
- 102 Clark, K. E. and Jahn, R. G., "Quasi-steady Plasma Acceleration," A.I.A.A. Journal, Vol. 8, No. 2, Feb. 1970, pp. 216-220.
- 103 York, T. M. and Jahn, R. G., "Pressure Distribution in the Structure of a Propagating Current Sheet," The Physics of Fluids, Vol. 13, No. 5, May 1970, pp. 1303-1309.
- 104 Jahn, R. G., "Pulsed Electromagnetic Gas Acceleration," NASA NGL 31-001-005 step-funding renewal proposal for period 1 October 1970 to 30 September 1971, June 11, 1970, Princeton Univ., Princeton, N. J.
- 105 Jahn, R. G., von Jaskowsky and Clark, K. E., "Pulsed Electromagnetic Gas Acceleration," NASA NGL 31-001-005, progress report for the period 1 January 1970 to 30 June 1970, Aerospace and Mechanical Sciences Rept. No. 634o, July 1970, Princeton Univ., Princeton, N. J.

## PROJECT REFERENCES

- 106 Turchi, P. J. and Jahn, R. G., "The Cathode Region of a Quasi-steady MPD Arcjet," A.I.A.A. Bulletin, Vol. 7, No. 9, Sept. 1970, p. 449.
- 107 Clark, K. E., DiCapua, M. S., Jahn, R. G. and von Jaskowsky, W. F., "Quasi-steady Magnetoplasma-dynamic Arc Characteristics," A.I.A.A. Bulletin, Vol. 7, No. 9, Sept. 1970, p. 449.
- 108 Turchi, P. J. and Jahn, R. G., "The Cathode Region of a Quasi-steady MPD Arcjet," A.I.A.A. Paper 70-1094, A.I.A.A. 8th Electric Propulsion Conference, Stanford, Calif., 31 Aug.-2 Sept. 1970.
- 109 Clark, K. E., DiCapua, M. S., Jahn, R. G. and von Jaskowsky, W. F., "Quasi-steady Magnetoplasma-dynamic Arc Characteristics," A.I.A.A. Paper 70-1095, A.I.A.A. 8th Electric Propulsion Conference, Stanford, Calif., 31 Aug.-2 Sept. 1970.
- 110 Turchi, P. J., "The Cathode Region of a Quasi-steady Magnetoplasma-dynamic Arcjet," Ph.D. thesis, Sept. 1970, Princeton Univ., Princeton, N. J.
- 111 Turchi, P. J. and Jahn, R. G., "The Cathode Region of a Quasi-steady Magnetoplasma-dynamic Arcjet," NASA NGL 31-001-005, Aerospace and Mechanical Sciences Rept. No. 940, Oct. 1970, Princeton Univ., Princeton, N. J.
- 112 Oberth, R. C., "Anode Phenomena in High-Current Discharges," Ph.D. thesis, Dec. 1970, Princeton Univ., Princeton, N. J.
- 113 Oberth, R. C. and Jahn, R. G., "Anode Phenomena in High-Current Discharges," NASA NGL 31-001-005, Aerospace and Mechanical Sciences Rept. No. 961, Dec. 1970, Princeton Univ., Princeton, N. J.
- 114 Di Capua, M. S. and Jahn, R. G., "Voltage-Current Characteristics of Parallel-Plate Plasma Accelerators," A.I.A.A. Bulletin, Vol. 8, No. 1, Jan. 1971, p. 40.
- 115 Oberth, R. C. and Jahn, R. G., "Anode Phenomena in High-Current Accelerators," A.I.A.A. Bulletin, Vol. 8, No. 1, Jan. 1971, p. 40.
- 116 Di Capua, M. S. and Jahn, R. G., "Energy Deposition in Parallel-Plate Plasma Accelerators," A.I.A.A. Paper 71-197, A.I.A.A. 9th Aerospace Sciences Meeting, New York, N. Y., 25-27 Jan. 1971.



## PROJECT REFERENCES

- 117 Oberth, R. C. and Jahn, R. G., "Anode Phenomena in High-Current Accelerators," A.I.A.A. Paper 71-198, A.I.A.A. 9th Aerospace Sciences Meeting, New York, N. Y., 25-27 Jan. 1971.
- 118 Jahn, R. G., Clark, K. E., Oberth, R. C. and Turchi, P. J., "Acceleration Patterns in Quasi-steady MPD Arcs," A.I.A.A. Journal, Vol. 9, No. 1, Jan. 1971, pp. 167-172.
- 119 Jahn, R. G., von Jaskowsky, W. F. and Clark, K. E., "Pulsed Electromagnetic Gas Acceleration," NASA NGL 31-001-005, semi-annual report for period 1 July 1970 to 31 December 1970, Aerospace and Mechanical Sciences Rept. No. 634p, January 1971, Princeton University, Princeton, N. J.
- 120 Jahn, R. G., von Jaskowsky, W. F. and Clark, K. E., "Pulsed Electromagnetic Gas Acceleration," NASA NGL 31-001-005 step-funding renewal proposal for the period 1 October 1971 to 30 September 1972, June 16, 1971, Princeton Univ., Princeton, N. J.
- 121 Clark, K. E., Jahn, R. G. and von Jaskowsky, W. F., "Exhaust Characteristics of a Quasi-steady MPD Accelerator," DGLR Symposium on Electric Space Thruster System, Braunschweig, Germany, June 22-23, 1971, DLR Mitt. 71-21, Teil 1, pp. 81-100.
- 122 Turchi, P. J. and Jahn, R. G., "Cathode Region of a Quasi-steady MPD Arcjet," A.I.A.A. Journal, Vol. 9, No. 7, July 1971, pp. 1372-1379.
- 123 Jahn, R. G., von Jaskowsky, W. F. and Clark, K. E., "Pulsed Electromagnetic Gas Acceleration," NASA NGL 31-001-005, semi-annual report for period 1 January 1971 to 30 June 1971, Aerospace and Mechanical Sciences Dept. No. 634q, July 1971, Princeton University, Princeton, N. J.
- 124 Cory, John S., "Mass, Momentum and Energy Flow from an MPD Accelerator," Ph.D. thesis, August 1971, Princeton University, Princeton, N. J.

## PROJECT REFERENCES

- 125 Cory, J. S. and Jahn, R. G., "Mass, Momentum and Energy Flow from an MPD Accelerator," NASA NGL 31-001-005, Aerospace and Mechanical Sciences Rept. No. 999, September 1971, Princeton University, Princeton, N. J.
- 126 Jahn, R. G., von Jaskowsky, W. F. and Clark, K. E., "Quasi-steady Plasma Acceleration," International Symposium on Dynamics of Ionized Gases, University of Tokyo, September 1971.
- 127 Di Capua, M. S., "Energy Deposition in the Parallel-Plate Plasma Accelerator," Ph.D. thesis, November 1971, Princeton University, Princeton, N. J.
- 128 Di Capua, M. S. and Jahn, R. G., "Energy Deposition in Parallel-Plate Plasma Accelerators," NASA 31-001-005, Aerospace and Mechanical Sciences Rept. No. 1015, December 1971, Princeton University, Princeton, N. J.
- 129 Parmentier, N., "Hollow Cathode, Quasi-steady MPD Arc," M.S.E. thesis, December 1971, Princeton University, Princeton, N. J.
- 130 Parmentier, N. and Jahn, R. G., "Hollow Cathode, Quasi-steady MPD Arc," NASA NGL 31-001-005, Aerospace and Mechanical Sciences Rept. No. 1023, December 1971, Princeton University, Princeton, N. J.
- 131 Jahn, R. G., von Jaskowsky, W. F. and Clark, K. E., "Pulsed Electromagnetic Gas Acceleration," NASA NGL 31-001-005, semi-annual report for period 1 July 1971 to 31 December 1971, Aerospace and Mechanical Sciences Report No. 634r, January 1972, Princeton University, Princeton, N. J.
- 132 Oberth, R. C. and Jahn, R. G., "Anode Phenomena in High-Current Accelerators," A.I.A.A. Journal, Vol. 10, No. 1, January 1972, pp. 86-91.
- 133 Clark, K. E., "Electric Propulsion," Astronautics and Aeronautics, Vol. 10, No. 2, February 1972, pp. 22-23.
- 134 Hixon, T. L., "Near-Ultraviolet Spectroscopic Studies of a Quasi-Steady Magnetoplasma Dynamic Arc," B.A. thesis, April 1972, Princeton University, Princeton, N. J.
- 135 Hixon, T. L., "Near-Ultraviolet Spectrographic Studies of AIII in an MPD Arc Discharge," Paper presented at the Northeastern Regional Student Conference, Rutgers University, New Brunswick, N. J., April 29, 1972.

## PROJECT REFERENCES

- 136 Clark, K. E., Jahn, R. G. and von Jaskowsky, W. F., "Distribution of Momentum and Propellant in a Quasi-Steady MPD Discharge," A.I.A.A. Bulletin, Vol. 9, No. 4, April 1972, p. 165.
- 137 Bruckner, A. P. and Jahn, R. G., "Exhaust Plume Structure in a Quasi-steady MPD Arc," A.I.A.A. Bulletin, Vol. 9, No. 4, April 1972, p. 166.
- 138 Clark, K. E., Jahn, R. G. and von Jaskowsky, W. F., "Measurements of Mass, Momentum and Energy Distributions in a Quasi-Steady MPD Discharge," A.I.A.A. Paper 72-497, A.I.A.A. 9th Electric Propulsion Conference, Bethesda, Md., 17-19 April 1972.
- 139 Bruckner, A. P. and Jahn, R. G., "Exhaust Plume Structure in a Quasi-Steady MPD Arc," A.I.A.A. Paper 72-499, A.I.A.A. 9th Electric Propulsion Conference, Bethesda, Md., 17-19 April, 1972.
- 140 Bruckner, A. P., "Spectroscopic Studies of the Exhaust Plume of a Quasi-steady MPD Accelerator," Ph.D. thesis, May 1972, Princeton University, Princeton, N. J.
- 141 Bruckner, A. P. and Jahn, R. G., "Spectroscopic Studies of the Exhaust Plume of a Quasi-steady MPD Accelerator," NASA NGL 31-001-005, Aerospace and Mechanical Sciences Rept. No. 1041, May, 1972, Princeton University, Princeton, N. J.
- 142 Jahn, R. G., von Jaskowsky, W. F. and Clark, K. E., "Pulsed Electromagnetic Gas Acceleration," NASA NGL 31-001-005 step-funding renewal proposal for the period 1 October 1972 to 30 September 1973, June 1972, Princeton University, Princeton, N. J.
- 143 Jahn, R. G., von Jaskowsky, W. F. and Clark, K. E., "Pulsed Electromagnetic Gas Acceleration," NASA NGL 31-001-005, semi-annual report for period 1 January 1972 to 30 June 1972, Aerospace and Mechanical Sciences Report No. 634s, July 1972, Princeton University, Princeton, N. J.
- 144 Kelly, A. J. and Clark, K. E., "Plasma Propulsion Systems," Aerospace and Mechanical Sciences Rept. No. 1074, September 1973, Princeton University, Princeton, N. J.
- 145 Greco, R. V., Bliss, J. R., Murch, C. K., Clark, K. E., and Kelly, A. J., "Resistojet and Plasma Propulsion System Technology," AIAA Paper 72-1124 (1972).

## PROJECT REFERENCES

- 146 Jahn, R. G., von Jaskowsky, W. F. and Clark, K. E., "Pulsed Electromagnetic Gas Acceleration," NASA NGL 31-001-005, semi-annual report for period 1 July 1972 to 31 December 1972, Aerospace and Mechanical Sciences Report No. 634t, January 1973, Princeton University, Princeton, N. J.
- 147 Fradkin, D. B., "Analysis of Acceleration Mechanisms and Performance of an Applied Field MPD Arcjet," Ph.D. thesis, March 1973, Princeton University, Princeton, N. J.
- 148 Jahn, R. G., von Jaskowsky, W. F. and Clark, K. E., "Quasi-Steady Plasma Acceleration," in Dynamics of Ionized Gases, Proceedings of the International Symposium on Dynamics of Ionized Gases sponsored by the International Union of Theoretical and Applied Mechanics, Tokyo, Japan, September 13-17, 1971, University of Tokyo Press, 1973, Edited by M. J. Lighthill, I. Imai and H. Sato.
- 149 von Jaskowsky, W. F., Jahn, R. G., Dutt, G. S. and Clark, K. E., "Impact Pressure Measurements in a Quasi-Steady MPD Discharge," Paper dedicated to Prof. H. Maecker, Technical University, Munich, Germany (April 1973).
- 150 Jahn, R. G., von Jaskowsky, W. F. and Clark, K. E., "Pulsed Electromagnetic Gas Acceleration," NASA NGL 31-001-005 step-funding renewal proposal for the period 1 October 1973 to 30 September 1974, June 1973, Princeton, New Jersey
- 151 Jahn, R. G., von Jaskowsky, W. F. and Clark, K. E., "Pulsed Electromagnetic Gas Acceleration, NASA NGL 31-001-005 semi-annual report for period 1 January 1973 to 30 June 1973, Aerospace and Mechanical Sciences Report No. 634u, July 1973, Princeton University, Princeton, N. J.
- 152 Boyle, M. J., and Jahn, R. G., "Effects of Insulator Ablation on the Operation of a Quasi-Steady MPD Arc," A.I.A.A. Paper 73-1090, A.I.A.A. 10th Electric Propulsion Conference, Lake Tahoe, Nev., Oct. 31-Nov. 2, 1973.
- 153 Saber, A. J. and Jahn, R. G., "Anode Power Deposition in Quasi-Steady MPD Arcs," A.I.A.A. Paper 73-1091, A.I.A.A. 10th Electric Propulsion Conference, Lake Tahoe, Nev., Oct. 31-Nov. 2, 1973.

## PROJECT REFERENCES

- 154 von Jaskowsky, W. F., Krishnan, M., Jahn, R. G. and Clark, K. E., "The Hollow Cathode in the Quasi-steady MPD Discharge," A.I.A.A. Paper 73-1092, A.I.A.A. 10th Electric Propulsion Conference, Lake Tahoe, Nevada, October 31-November 2, 1973.
- 155 Jahn, R. G., von Jaskowsky, W. F. and Clark, K. E., "Pulsed Electromagnetic Gas Acceleration," NASA NGL 31-001-005, semi-annual report for period 1 July 1973 to 31 December 1973, Aerospace and Mechanical Sciences Report No. 634v, January 1974, Princeton University, Princeton, N. J.
- 156 Saber, A. J., "Anode Power in the Quasi-steady MPD Thruster," Ph.D. thesis, May 1974, Princeton University, Princeton, N. J.
- 157 Saber, A. J. and Jahn, R. G., "Anode Power in the Quasi-steady MPD Thruster," Aerospace and Mechanical Sciences Report No. 1128, May 1974, Princeton University, Princeton, N. J.
- 158 Jahn, R. G., von Jaskowsky, W. F. and Clark, K. E., "Pulsed Electromagnetic Gas Acceleration," NASA NGL 31-001-005 step-funding renewal proposal for the period 1 October 1974 to 30 September 1975, June 1974, Princeton, N. J.
- 159 Jahn, R. G., von Jaskowsky, W. F. and Clark, K. E., "Pulsed Electromagnetic Gas Acceleration," NASA NGL 31-001-005, semi-annual report for the period 1 January 1974 to 30 June 1974, Aerospace and Mechanical Sciences Report No. 634w, July 1974, Princeton University, Princeton, N. J.
- 160 Dutt, G. S. and Jahn, R. G., "Acoustics of the Piezo-electric Pressure Probe," Aerospace and Mechanical Sciences Report No. 1179, August 1974, Princeton University, Princeton, N. J.
- 161 Bruckner, A. P. and Jahn, R. G., "Exhaust Plume Structure in a Quasi-steady MPD Accelerator," A.I.A.A. Journal, Vol. 12, No. 9, September 1974, pp. 1198-1203.

## PROJECT REFERENCES

- 162 Boyle, M. J., "Acceleration Processes in the Quasi-steady Magnetoplasmadynamic Discharge," Ph.D. thesis, October 1974, Princeton University, Princeton, N.J.
- 163 Boyle, M. J. and Jahn, R. G., "Acceleration Processes in the Quasi-steady Magnetoplasmadynamic Discharge," Aerospace and Mechanical Sciences Report No. 1188, October 1974, Princeton University, Princeton, N. J.
- 164 von Jaskowsky, W. F., Krishnan, M., Clark, K. E. and Jahn, R. G., "Hollow Cathode Physics," Proceedings IIIrd European Electric Propulsion Conference, Hinterzarten, Federal Republic of Germany, DGLR-Fachbuchreihe, Band 5, October 14-18, 1974, pp. 128-139.
- 165 Clark, K. E., "Survey of Electric Propulsion Capability," A.I.A.A. Paper 74-1082, A.I.A.A./S.A.E. 10th Propulsion Conference, San Diego, California, October 21-23, 1974.
- 166 Jahn, R. G., von Jaskowsky, W. F. and Clark, K. E., "Pulsed Electromagnetic Gas Acceleration," NASA NGL 31-001-005 semi-annual report for period 1 July 1974 to 31 December 1974, Aerospace and Mechanical Sciences Report 634x, January 1975, Princeton University, Princeton, N. J.
- 167 Krishnan, M., von Jaskowsky, W. F., Clark, K. E. and Jahn, R. G., "Hollow Cathode Characteristics in High Current Discharges," A.I.A.A. Paper 75-395, A.I.A.A. 11th Electric Propulsion Conference, New Orleans, La., 19-21 March 1975.
- 168 Boyle, M. J., Clark, K. E. and Jahn, R. G., "Flow Field Characteristics and Performance Limitations of Quasi-steady Magnetoplasmadynamic (MPD) Accelerators," A.I.A.A. Paper 75-414, A.I.A.A. 11th Electric Propulsion Conference, New Orleans, La., 19-21 March 1975.
- 169 Campbell, E. M., von Jaskowsky, W. F., Clark, K. E. and Jahn, R. G., "Plasmadynamic Laser Processes in Relaxing Plasma Flows," A.I.A.A. Paper 75-852, A.I.A.A. 8th Fluid and Plasma Dynamics Conference, Hartford, Connecticut, June 1975.
- 170 Jahn, R. G., von Jaskowsky, W. F. and Clark, K. E., "Pulsed Electromagnetic Gas Acceleration," NASA NGL 31-001-005 step-funding renewal proposal for the period 1 October 1975 to 30 September 1976, June 1975, Princeton University, Princeton, N. J.

## GENERAL REFERENCES

- A-1 Malliaris, A. C. et al, "Quasi-Steady MPD Propulsion at High Power," Final Technical Report AVSD-0146-71-RR, AVCO Corporation, February 1971.
- A-2 CRC Handbook of Lasers with Selected Data on Optical Technology. The Chemical Rubber Co. (1971).
- A-3 Bennett, W. R. Jr., Knutson, J. W., Mercer, G. N. and Detch, J. L., Applied Physics Letters 4, 180 (1964)
- A-4 Gordon, E. I., Labuda, E. F., Miller, R. C. and Webb, C. E. in Physics of Quantum Electronics, ed. by Kelley, P.L., Lax, B. and Tannenwald, P. E. (McGraw Hill, 1965) pp. 664-673.
- A-5 Bates, P. R., Kingston, A. E. and McWhirter, R. W. P., "Recombination Between Electrons and Atomic Ions," Proceedings of the Royal Society, London A 267, 297 (1962).
- A-6 Bohn, W. L., "Calculations of Inversions in a Decaying Plasma," Tenth International Conference on Phenomena in Ionized Gases, 1971.
- A-7 Kirchhoff, R. H., Peterson, E. W. and Talbot, L., "Langmuir Probe Response in a Transition Regime," AIAA Journal, Vol. 9, No. 9, September 1971.
- A-8 Johnson, E. O., Malter, L., "A Floating Double Probe Method for Measurements in Gas Discharges," Physical Review 80, 58 (1950).
- A-9 Sanmartin, J. R., "End Effects of the Langmuir Probe in a Flowing Plasma," Physics of Fluids, 15, 391 (1972).
- A-10 Chung, P. M., Talbot, L., Touryan, K. J., "Electric Probes in Stationary and Flowing Plasmas," AIAA Journal, Vol. 12, No. 2, February 1974.
- A-11 Chen, F. F., "Electric Probes," in Plasma Diagnostic Techniques (R. H. Huddlestone and S. L. Leonard, eds.), Academic Press, New York, 1965.
- A-12 Chung, P. M., Talbot, L. and Touryan, K. J., Electric Probes in Stationary and Flowing Plasmas, Springer-Verlag, New York, 1975.

## APPENDIX A: Semi-annual Statement of Expenditures

## PULSED ELECTROMAGNETIC GAS ACCELERATION

NASA NGL 31-001-005

1 January 1975 to June 30, 1975

DIRECT COSTS

I. Salaries		
Professional	\$ 14,313	
Technicians	11,765	
Students	3,050	
Supporting Staff	<u>1,835</u>	
		\$ 30,963
II. Employee Benefits (22½%)		6,280
III. Materials and Services		7,194
IV. Travel		1,477
V. Tuition		<u>2,400</u>
	TOTAL DIRECT COSTS	\$ 48,314

INDIRECT COSTS

VI. Overhead (86½%)		<u>26,783</u>
	TOTAL	\$ 75,097