

VOLUME I

A STATE-OF-THE-ART REVIEW  
OF TRANSPORTATION SYSTEMS EVALUATION TECHNIQUES  
RELEVANT TO AIR TRANSPORTATION

NASA Contract NAS2-8324

August 28, 1975

Department of Civil Engineering  
Washington University  
St. Louis, Missouri 63130

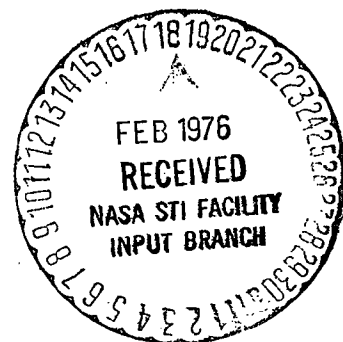

Dr. Lonnie E. Haefner  
Principal Investigator

TABLE OF CONTENTS

	<u>Page</u>
CHAPTER I - INTRODUCTION . . . . .	1
Introduction-Report Objectives . . . . .	1
Aspects of Transportation System	
Location and Design Decisions . . . . .	1
The Concept of Cost-Effectiveness . . . . .	7
Overview of Possible Modelling Processes . . . . .	10
CHAPTER II - TRADITIONAL ENGINEERING ECONOMIC EVALUATION	
TECHNIQUES . . . . .	13
Introduction . . . . .	13
Minimum Average Annual Cost . . . . .	13
Benefit-Cost Ratio . . . . .	14
Rate of Return . . . . .	14
Net Benefits . . . . .	15
Conclusions-Further General Comments on Evaluation . . . . .	15
CHAPTER III - COMPLEX COST-EFFECTIVENESS EVALUATION APPROACHES .	18
Introduction . . . . .	18
Optimization Approaches . . . . .	18
Linear Programming . . . . .	18
Non-Linear Programming . . . . .	21
Goal Programming . . . . .	24
Dynamic Programming . . . . .	27
Statistical Decision Theory . . . . .	30
Simple Decision Theory . . . . .	30
Bayesian Decision Theory . . . . .	33
Markovian Decision Theory . . . . .	44
Relevance of Statistical Decision Theory Concepts . . . . .	48
Game Theory . . . . .	49
Forward-Seeking Models . . . . .	55
CHAPTER IV - SIMPLE AND HUERISTIC COST-EFFECTIVENESS APPROACHES.	59
Introduction . . . . .	59
Ranking Method . . . . .	59
Rating Methods . . . . .	61
Rank Based Expected Value . . . . .	63
Value Matrix . . . . .	66
Desirability Ratings (Utility Theory) . . . . .	70
CHAPTER V - APPROACHES EMPLOYING WELFARE ECONOMICS . . . . .	74
Introduction-Transportation and Equity . . . . .	74
Concepts from Welfare Economics . . . . .	76
Example Problem . . . . .	77
Conclusions . . . . .	98
Further Research . . . . .	99

	<u>Page</u>
CHAPTER VI - EMERGING CITIZEN PARTICIPATION PROGRAMS . . . . .	100
Introduction . . . . .	100
The Boston Transportation Planning Review . . . . .	100
West Prince Georges County, Maryland Transportation Alternatives Study . . . . .	102
Discussion and Comparison . . . . .	104
BART Impact Study . . . . .	105
Conclusions-Trajectory of Case Study Activities . . . . .	107
 CHAPTER VII - CONCLUSIONS - SYNTHESIS OF RESEARCH AND ENGINEERING OPERATIONAL ISSUES . . . . .	 109
 APPENDIX - SELECTED ANNOTATIONS AND BIBLIOGRAPHIC LISTINGS . . . . .	 111
Engineering Economic Techniques . . . . .	111
Minimum Average Annual Cost . . . . .	111
Benefit-Cost Ratio . . . . .	113
Net Benefits . . . . .	118
Complex Cost-Effectiveness Evaluation Approaches . . . . .	120
Linear Programming . . . . .	120
Non-Linear Programming . . . . .	121
Goal Programming . . . . .	121
Dynamic Programming . . . . .	122
Bayesian Decision Theory . . . . .	123
Markovian Decision Theory . . . . .	124
Game Theory . . . . .	124
Simple and Hueristic Cost-Effectiveness Approaches . . . . .	125
Ranking Techniques . . . . .	125
Rating Techniques . . . . .	127
Expected Value Techniques . . . . .	129
Value Matrix Techniques . . . . .	130
Desirability Rating Techniques . . . . .	131
Approaches Employing Welfare Economics . . . . .	135
Emerging Citizen Participation Programs . . . . .	135

LIST OF FIGURES

<u>FIGURE NO.</u>	<u>TITLE</u>	<u>Page</u>
1	General Systems Analysis in the Decision Process	5
2	Forward-Seeking Process	11
3	Backward-Seeking Models	12
4	Conceptualization of a Dynamic Programming Algorithm	28
5	Aspects of the Bayesian Decision Process	36
6	Decision Tree	39
7	Backwards Induction in Sequential Sampling	43
8	Payoff Matrix	51
9	Payoff Matrix	52
10	Three Actor Sample	53
11	Generated Forward-Seeking Approach in the Highway Safety Problem	56
12	Use of Simulation in Modelling Highway Safety Processes	57
13	Original Road Network Travel Conditions	78
14	Freeway Travel Conditions	79
15	Urban Systems Theory of Transportation Decisions	106

LIST OF TABLES

<u>TABLE NO.</u>	<u>TITLE</u>	<u>Page</u>
1	Impact Elements	3
2	Simple Decision Theory Problem Examples	34
3	Example Ranking of Alternatives vs. Dwelling Units Destroyed	59
4	Ranking Example for Five Alternatives and Seven Factors	60
5	Rating Example	62
6	Rank-Based Expected Value Example	64
7	Example of Value Matrix Application	67
8	ADT and Income Data	80
9	Perceived Cost Paths for All Trips	84
10	Minimum Perceived Cost Path Matrix- Both Crossroads Open	89
11	Minimum Perceived Cost Matrix- Both Crossroads Terminated	90
12	Minimum Perceived Cost Matrix- One Crossroad Terminated-One Open	91
13	Capital and Maintenance Cost Estimates	92
14	Discounted Perceived Costs of Each Alternative	93
15	Freeway Benefits	94
16	Minimum Cost Analysis Method	95
17	Welfare Criteria Analysis	96

## CHAPTER I - INTRODUCTION

### Introduction-Report Objectives

The objective of this state-of-the-art report on evaluation literature and techniques is to synthesize relevant information on the mathematical techniques and philosophical approaches being taken at the research and operating level with respect to evaluation and implementation of ground transportation systems. Many, if not all, of these approaches have parallel problem structures to air transportation problems which require major private and public works investments, and have far-reaching consequences on many components of society. The synthesis will be developed by devoting the remainder of this introductory chapter to basic viewpoints held with respect to transportation system decision processes.

Subsequently, relevant research and operational algorithmic structures will be discussed in some depth. For each of them, generic mathematical techniques, their strengths and weaknesses, and selected bibliographic annotations and listings will be presented. Comments will be offered as to the general status and approaches used in the current nationally documented citizen participation studies underway, and their use of the research techniques under study. Ultimately, conclusions will be offered as to general status and relevance of the approaches to air transportation and the further use of formal evaluation models in the context of the present research activity.

### Aspects of Transportation System Location and Design Decisions

The modern transportation system decision process requires the generation of a location and design alternative for the facility,

predicting the consequences, evaluating these consequences, and accepting, modifying or rejecting the alternative. As such, prediction and evaluation is required for the following:

- 1.) Construction and right-of-way costs.
- 2.) User costs of fuel, oil, wear and tear on vehicle.
- 3.) Safety costs--accident rate; costs of accidents.
- 4.) Maintenance costs of the facility.
- 5.) Environmental and social impacts as listed in Table 1.

Obviously, the decision surrounding such a wide and interacting set of consequences is complex, and evaluation is difficult. Some weighting technique of part or all of the above consequences may be desirable. Thus, the process should be actively involved within a framework containing the following elements, as shown in Figure 1.

Objectives: The transportation system decision should be a step toward accomplishing relevant local, state or federal goals which improved transportation systems can enhance, such as increased safety, lower travel time, lower commodity rates and prices, increased cultural and social mobility, increased trade between regions, etc.

Criteria: Where possible, yardsticks for measurement of attaining the above objectives, termed criteria, should be employed. Relating to the above, some examples include: for increased safety--accident rate/mvm; lower travel time--trip time in minutes from point A to point B; increased trade--tons of commodity x shipped from A to B after facility opening as compared to before.

TABLE 1 - Impact Elements

1. EFFECTS ON THE STATIONARY ENVIRONMENT

1. Aesthetics
2. Agriculture
3. Aquatic life protection
4. Coastal areas, estuaries, waterfowl refuges and beaches
5. Farms, forests and outdoor recreation areas
6. Flood plains and watersheds
7. Minearl land reclamation
8. Navigable airways
9. Navigable waterways
10. Raw material production
11. Scenic enhancement
12. Soil, plant life, erosion and hydrological conditions
13. Wildlife protection
14. Other topographic factors

2. EFFECTS ON THE TRANSIENT ENVIRONMENT

1. Air quality and air pollution control
2. Chemical contamination and food production
3. Climatological features
4. Disease and rodent control
5. Health hazards and other dangers
6. Herbicides and pesticides
7. Human ecology
8. Noise control and abatement
9. Radiation and radiological health
10. Sanitation and waste systems
11. Water quality and water pollution control

3. NEIGHBORHOOD AND COMMUNITY IMPACTS

1. Activity patterns
2. Community pride
3. Cultural and recreational opportunities
4. Community protection services
5. Domestic privacy
6. Economic stability of the community
7. Educational systems
8. Employment opportunities
9. Energy generation and supply
10. Historical and archeological sites
11. Housing and building displacement
12. Impacts on other institutions
13. Land values and uses
14. Neighborhood disruption
15. Personal and community identity

(Continued)



TABLE 1 (Continued)

16. Population distribution
17. Preservation of open space
18. Property tax base
19. Relocation assistance
20. Special impacts on low-income areas
21. Utility services
22. Visual quality of the environment
23. Zoning regulations

4. TRADITIONAL FACTORS IN IMPROVEMENT ANALYSIS

1. Business and trade
2. Congestion in urban areas
3. Construction material availability
4. Disruption during construction
5. Existing highway systems
6. Facility appearance
7. Transportation system costs and economics
8. International implications
9. Land access
10. Low travel costs
11. Modal choice and compatibility
12. Multiple-use of highway rights-of-way
13. National defense
14. Regional comprehensive planning
15. Special impact on regional jurisdictions
16. Tourism
17. Transport system reliability
18. Transportation and handling of hazardous materials
19. Transportation safety
20. Travel convenience and efficiency

FIGURE 1

GENERAL SYSTEMS ANALYSIS IN THE DECISION PROCESS

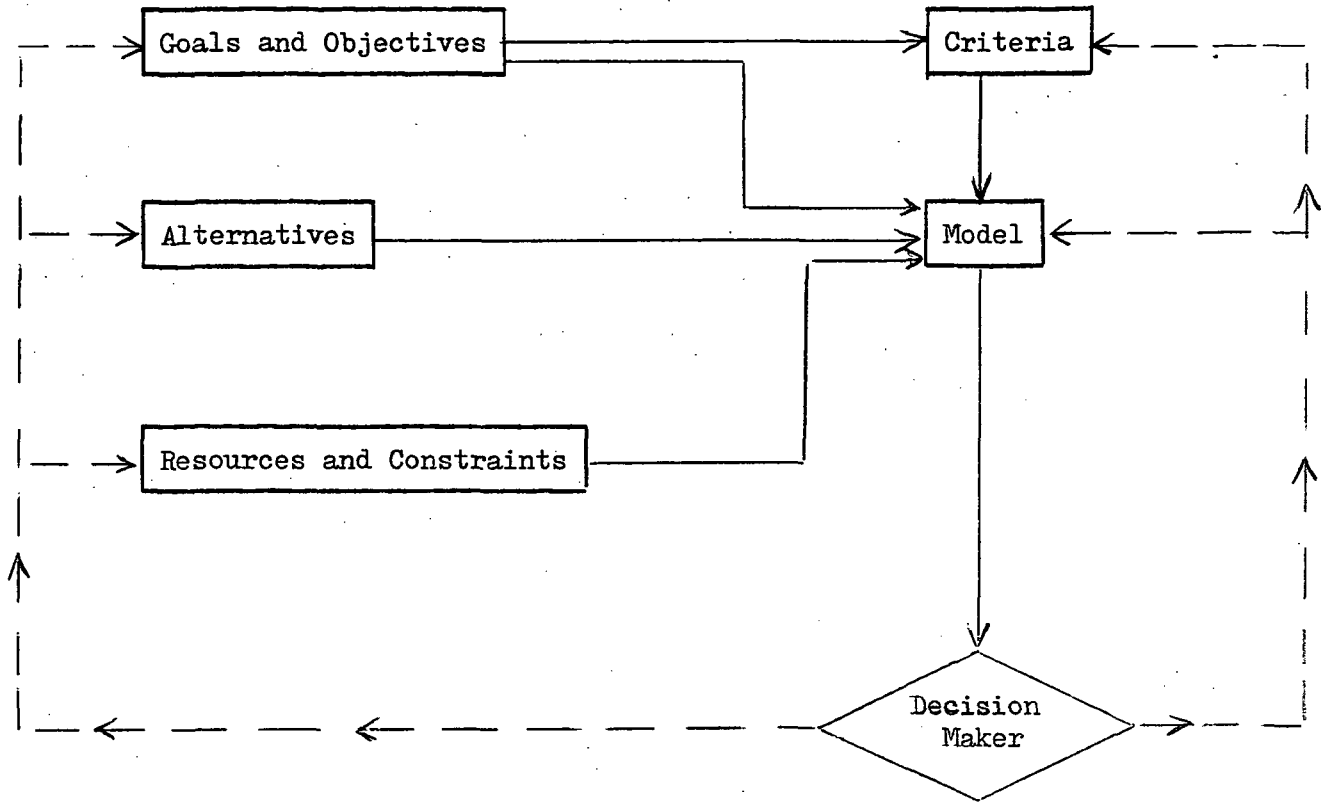

Alternatives: The reasonable set of possible locations and designs to be considered in fulfilling the objectives of improved transportation. That is, the composites of alignment, profile, right-of-way, cross-section, drainage, interchange and intersection configurations, and control types and devices that synthesize into a design and/or location.

Resources and Constraints: Usually, money, time, soil type, original topography and surrounding land use, manpower, engineering designs, and local political pressures and viewpoints can be considered resources or constraints for a location and design problem, depending on the degree of positiveness or negativeness of each of them as they relate to the local problem under consideration.

Model: An evaluation technique, termed a "model" should attempt to integrate the aspects of the decision within the above framework of objectives, criteria, alternatives, resources and constraints and yield a set of feasible alternative locations or designs, or if possible, a "best" location or design alternative.

Although many evaluation methods, ranging from conceptual to fully tested and operational, are currently in use or proposed, the utility of these methods depends greatly upon the knowledge, experience and personal values of the evaluator(s). In addition, many of the methods available have application to only limited factors (i.e., user costs and benefits as in benefit-cost analysis) or project situations. The use of an evaluation method does not replace the elements of discussion and compromise which are needed to achieve a solution which optimizes the public interest.

The Concept of Cost-Effectiveness

The most constructive and representative continuing trend in evaluation research for the appropriate employment of all techniques exists within the general context of an approach termed cost effectiveness. In this approach, the applied and theoretical evaluation techniques being discussed herein are used to allow positive and negative aspects of a transportation systems decision to be worked out for each interested subgroup, ultimately allowing them to trade off levels of consequences for each alternative, subsequently yielding a best location and/or design for their preference structure. For example:

Assume a hypothetical situation where three alternatives for realignment and upgrading of an obsolete highway facility are presented. A simple table of their crucial impacts might be as follows:

Typical Cost-Effectiveness Analysis of Alternatives

Alternative	Construction & R-O-W Cost Net Present Value	Decrease in Corridor Travel Time to CBD	Predicted Accident Rate Acc/mvm	Residences Taken	Business Establishments Taken
1	\$1,500,000	12 min.	1.0 Acc/mvm	100	25
2	\$1,000,000	10 min.	1.5 Acc/mvm	60	20
3	\$700,000	5 min.	4.0 Acc/mvm	15	14

Each impact, graphed against a capital and right-of-way cost axis, looks as follows:

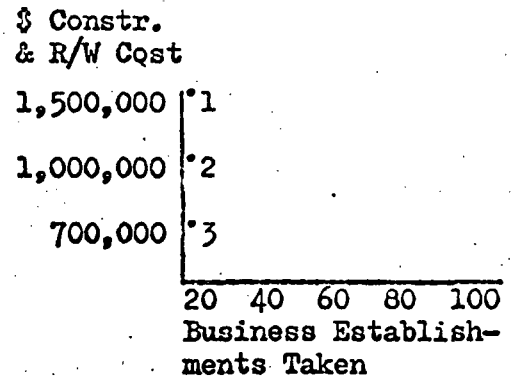
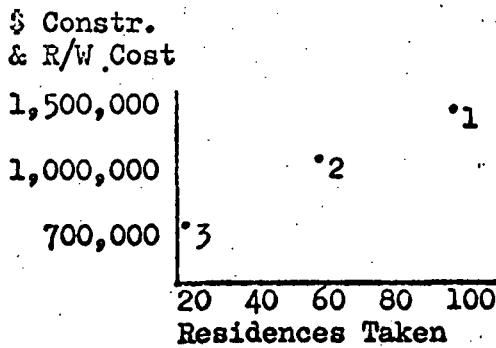
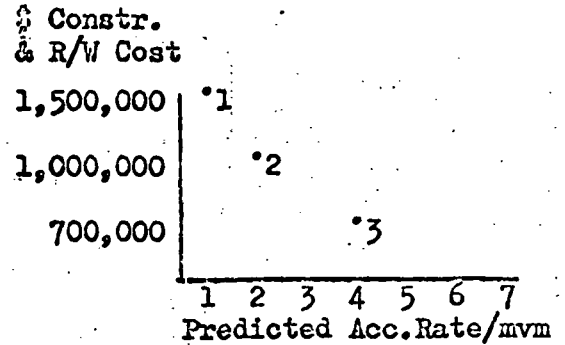
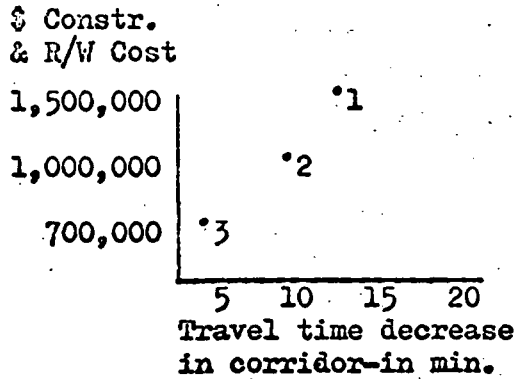

Alternatively, residences taken could be shown in dollars tax loss to the community, and businesses taken could have been expressed in total dollar volume of business loss to the area.

However, community subgroup A may put the following weightings or interpretations of effectiveness or levels of desirability on these alternatives as shown on the axes below:

tr  
st  
to  
we  
de  
ac  
bo  
ea  
th

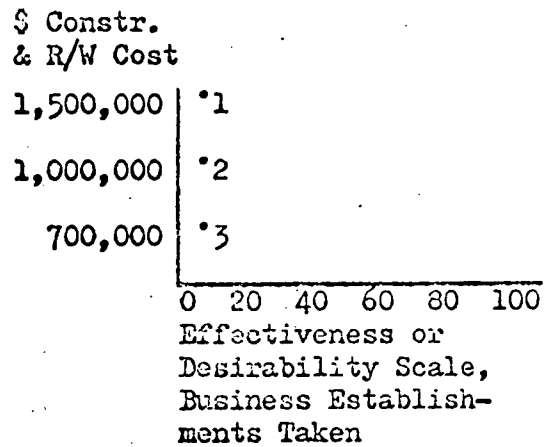
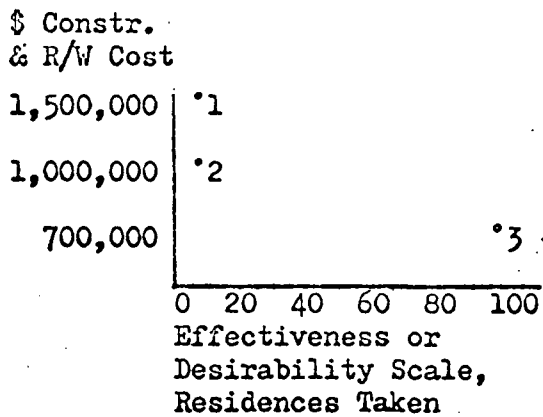
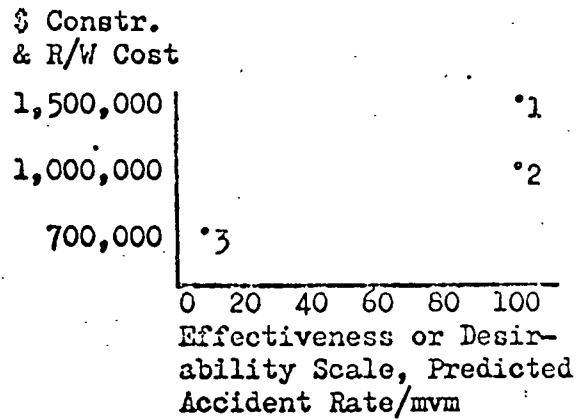
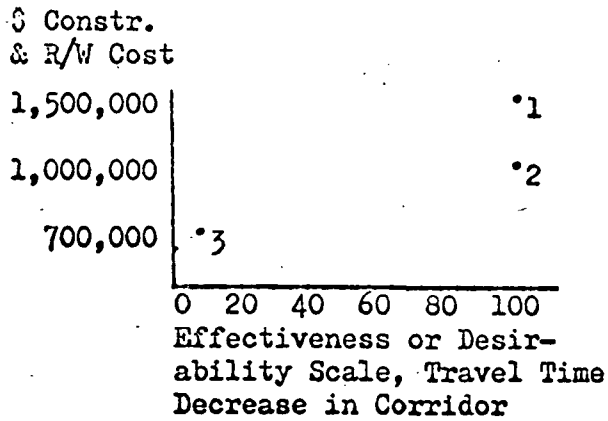

In light of these, they may continue to investigate the alternatives, trading off between alternatives 1, 2, and 3 within their subgroup value structure, to ultimately decide on a location and design. It is important to be aware another subgroup will probably attach substantially different weightings or levels of desirability to these impacts. The values and decisions on alternatives by each subgroup are carried forth into political activity for implementation (council meetings, public hearings, zoning boards, etc.), and there, the tradeoffs are re-examined within and across each group's values, yielding rejection, acceptance or modification of the location and design alternatives.

### Overview of Possible Modelling Processes

The general approaches to all techniques relating to cost-effectiveness analysis are those generalized in Figures 2 and 3, termed "backward seeking" and "forward seeking," for their different approaches to the alternative generation and decision process.<sup>1,2</sup> One notes that in the forward-seeking approach, an alternative is generated, consequences are predicted and evaluated, and compared against some criterion of effectiveness, and either the alternative is accepted, or the process is re-initiated, with the subsequent generation of a new alternative. In contrast, the backward-seeking models begin by prescribing levels of effectiveness at the outset, which are to be met as constraints, and seek only the minimum cost solution for attaining these stated levels. This approach, where applicable, is usually made possible through the existence of some well-defined formal algorithms from the fields of mathematical programming and/or statistical decision theory.

In either the forward- or backward-seeking formats, the criteria on rates, the information on costs, and the standard engineering economic evaluation techniques of net benefits, benefit cost ratio, etc., reviewed in Chapter II, can all be incorporated as levels of effectiveness, objectives, or consequences. One should remain aware of this as the various research techniques are individually reviewed throughout the text.

---

<sup>1</sup>Edward K. Morlok, A Goal-Directed Transportation Planning Model, Research Report, The Transportation Center, Northwestern University, Evanston, Illinois, January, 1969.

<sup>2</sup>H. W. Bruck, "Problems of Planning for the Future: The Marriage of the White Queen and Tiresias," 1966 National Transportation Symposium, American Society of Mechanical Engineers, New York, pp. 79-82.

FIGURE 2

**FORWARD-SEEKING PROCESS**

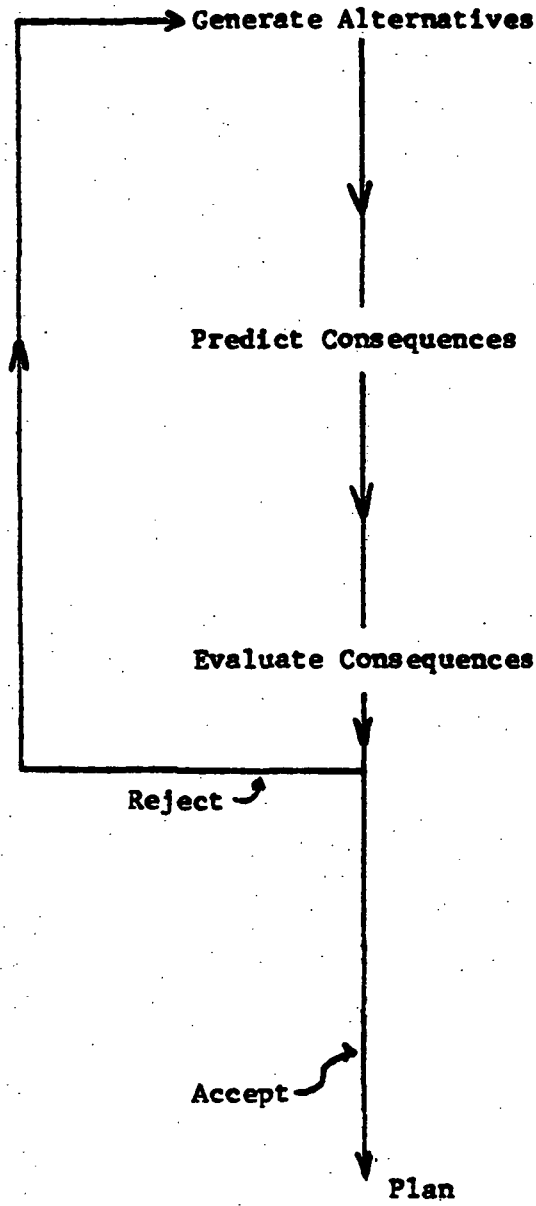
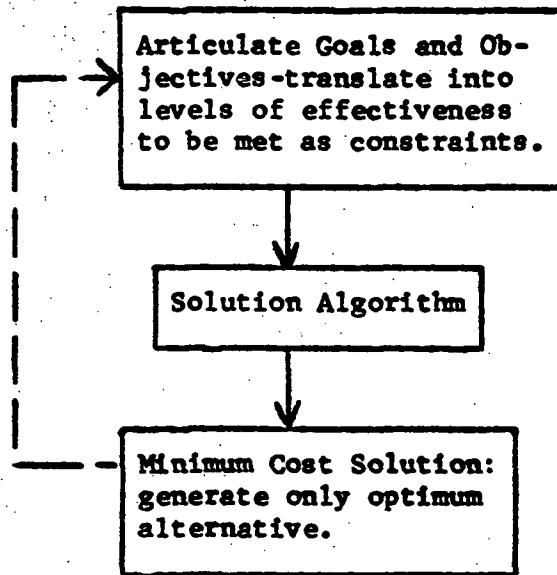



FIGURE 3

**BACKWARD-SEEKING MODELS**



## CHAPTER II - TRADITIONAL ENGINEERING ECONOMIC EVALUATION TECHNIQUES

### Introduction

The engineering-economic evaluation techniques are noted in several standard texts, and have become traditional instruments of evaluation in several public works and private investment decisions. They typically work with mutually exclusive alternatives, and the primary choice variable is monetary cost or benefit or some function thereof, developed through the several criteria discussed below. Several private airline vehicle supply and maintenance programs have been assembled through such techniques, and initial decisions prior to environmental legislation with respect to airport location used such criteria in arriving at an economically sound choice among site location and design alternatives.

### Minimum Average Annual Cost

The choice variable is  $TC_{j,\bar{t}}$  below, where:

$$TC_{j,\bar{t}} = (crf_{i,n})C_{j,0} + O_{j,\bar{t}} + U_{j,\bar{t}} + A_{j,\bar{t}}$$

where  $(crf_{j,n})C$  = annualized capital costs

$O_{j,\bar{t}}$  = annualized operating and maintenance costs in average year  $\bar{t}$

$U_{j,\bar{t}}$  = annualized vehicle and user operating costs in average year  $\bar{t}$

$A_{j,\bar{t}}$  = annualized accident costs in average year  $\bar{t}$

$n$  = service life

$i$  = interest rate

$crf$  = capital recovery factor

$j$  = design alternative  $j$  for a site.

In this method, all benefits are assumed equal, and the minimum cost design is chosen for execution. Obviously the assumption of equal benefits of all design alternatives is questionable in most cases.

### Benefit-Cost Ratio

This method develops a ratio from the dollar savings in user costs resulting from the improvement, divided by the difference between the total annual costs of the proposed alternative and the present configuration. That is:

$$B_j/C_j = \frac{R_{\bar{t}} - R_{j,\bar{t}}}{TC'_{j,t} - TC_{\bar{t}}}$$

where  $R_{\bar{t}}$  = total annual user costs for the present facility

$R_{j,\bar{t}}$  = total annual user costs for the proposed facility

$TC'_{j,\bar{t}} = (crf_{i,n})C_{j,0} + O_{j,\bar{t}}$

$TC_{\bar{t}} = O_{\bar{t}}$  .

Some problems associated with this method include the inability to quantify some benefits, such as comfort and convenience, environmental and regional impacts, and the difficulty of the decision-maker in understanding this method and its further incremental analysis.

### Rate of Return

This method solves the following equation for the interest rate  $i$ , which equates total amount of benefits and total annual costs:

$$(TC'_{j,\bar{t}} - TC_{\bar{t}}) = (R_{\bar{t}} - R_{j,\bar{t}})$$

where  $TC'$ ,  $R$ , and  $R_j$  are as defined above. Project design alternatives are ranked in order of interest rate.

This method is also difficult for the decision-maker to understand, and presents the same quantification problems discussed in the section on the benefit-cost ratio method. Further the philosophical viewpoint

of the evaluation team must come in to play here, as this approach perceives the problem cast in a profit-maximizer context typical of the private investment sector. Such a viewpoint may not be relevant to the emerging societal welfare viewpoint with respect to public works decisions. This will be dealt with in detail in the section on Welfare Economics.

### Net Benefits

This method takes the difference of the sum of the discounted benefits for each year of the project life minus the sum of discounted costs for each year of the project life:

$$NB_j = \sum_{t=0}^n (pwf_{i,t})(R_t - R_{j,t}) - \sum_{t=0}^n (pwf_{i,t})(TC'_{j,t})$$

where  $pwf_{i,t}$  = present worth factor for interest  $i$  in year  $t$ , and  $R$ ,  $R_j$  and  $TC'$  as defined before. The alternative with the highest positive net benefits is chosen.

This method is most pleasing of all forms, due to its ease in being readily understood, and the ability to include any elements that can be monetized, and no rigid requirements of comparing entities with identical project lives.

### Conclusions--Further General Comments on Evaluation

It is appropriate to conclude this chapter with some general comments which are relevant to the direction of our future research efforts, when viewed from the perspective of the present state of engineering-economic evaluation techniques available, versus the issues in Chapter I. In essence, these comments may be viewed as an informal discussion of requirements for broadening the evaluation format through the research and examples of the remaining chapters.

1.) The present techniques all evaluate for a given state-of-the-world, i.e., a unique and supposed certain combination of traffic, environment, community response, costs and savings. It is appropriate to point out that the true state-of-the-world may be uncertain. However, for planning purposes, it is necessary to predict some, or all of the operational factors which are relevant to the evaluation process. The necessary knowledge for such predictions may be incomplete, particularly in the case of complex occurrences. Hence, any modelling effort should have the ability to deal with uncertainty, and to incorporate varying amounts of information into the decision-making process.

2.) Any capital improvement will have certain multi-dimensional cost and effectiveness outputs, and not all of these can be evaluated quantitatively. In particular, the concept of evaluating a process in purely monetary terms can be disputed on several grounds, a few of which are:

a.) The concept of placing a dollar value on certain aspects of the decision such as human life, cultural and amenity attributes, is erroneous, from the points of view of worth to society, and complex life-style relationships, both of which are themselves multi-dimensional, and require an analytic approach properly tempered with humanism.

Given such complex multi-dimensional decision characteristics, it is worthwhile to consider further aspects of our analysis on the basis of incorporating present criteria and evaluation techniques into structures which deal with multi-dimensional considerations.

This will be explored and developed in future chapters, in conjunction with the consideration of methodologies for further generation and evaluation of alternatives.

## CHAPTER III - COMPLEX COST-EFFECTIVENESS EVALUATION APPROACHES

### Introduction

This chapter presents the core of on-going algorithmic research techniques likely to get continued attention at the theoretical level for improving the capability to structure and manipulate transportation system decisions. The discussion deals with the mathematical formats, a critique of their capabilities and commentary on their general relevance to transportation decision processes. The contents include the classical optimization approaches, statistical decision theory, and a brief overview of simulation procedures. With the exception of the simulation process, the entirety of these techniques can be conceived of as "backward seeking or goal directed" models, in that, through their mechanics, they structure the problem so as to iterate to a "best" or optimum decision, or packet of interrelated decisions.

### Optimization Approaches-Linear Programming

Linear programming is a goal-directed evaluation tool which deals with the problem of allocating limited resources among competing activities in an optimal manner. Mathematically, the general form of the problem is the following: Find  $x_1, x_2, \dots, x_n (x_i \geq 0)$  which maximizes, or minimizes the objective function  $Z_x = c_1x_1 + c_2x_2 + \dots + c_nx_n$  subject to the restrictions:

$$a_{11}x_1 + a_{12}x_2 + \dots + a_{1n}x_n \geq b_1$$

$$a_{21}x_1 + a_{22}x_2 + \dots + a_{2n}x_n \geq b_2$$

$$\begin{array}{cccc} \vdots & \vdots & \vdots & \vdots \\ \vdots & \vdots & \vdots & \vdots \\ \vdots & \vdots & \vdots & \vdots \end{array}$$

$$a_{m1}x_1 + a_{m2}x_2 + \dots + a_{mn}x_n \geq b_m$$

$$x_1 \geq 0, x_2 \geq 0 \dots x_n \geq 0$$

In this formulation, there are  $n$  competing activities for the resources. The variables  $x_1, x_2 \dots x_n$  are choice variables representing the levels of each of the  $n$  activities to be allocated.  $Z$  is the chosen overall measure of effectiveness.  $c_j$  is the unit increase in effectiveness that would result from a unit increase in  $x_j$ . The number of relevant scarce resources is  $m$ , so that each of the first  $m$  linear inequalities above represents a restriction on the availability of one of these resources.  $b_i$  is the amount of resource  $i$  available to the  $n$  activities.  $a_{ij}$  is the amount of resource  $i$  consumed by each unit of activity  $j$ . Therefore, the left side of these inequalities is the total usage of the respective resources. The restrictions  $x_j \geq 0$  rule out negative activity levels.

An alternative and extremely useful formulation of linear programming is that of the dual. The dual is formed by transposing the rows and columns of constraint coefficients, transposing the coefficients of the objective function and the righthand side of the constraints, reversing the inequalities and minimizing (maximizing) instead of maximizing (minimizing). Mathematically, the dual takes the following form: Find  $y_1, y_2 \dots y_n$ , ( $y_i \geq 0$ ) in order to minimize (maximize)

$$U = b_1 y_1 + b_2 y_2 + \dots + b_m y_m$$

subject to the restrictions

$$a_{11} y_1 + a_{21} y_2 + \dots + a_{m1} y_m \geq c_1$$

$$a_{12} y_1 + a_{22} y_2 + \dots + a_{m2} y_m \geq c_2$$

$$\begin{array}{ccc} \cdot & \cdot & \cdot \\ \cdot & \cdot & \cdot \\ \cdot & \cdot & \cdot \\ \cdot & \cdot & \cdot \end{array}$$

$$a_{1n} y_1 + a_{2n} y_2 + \dots + a_{mn} y_m \geq c_n$$



From the resource allocation standpoint, all constants  $a_{ij}$ ,  $b_i$ , and  $c_j$  are defined as before. The new decision variable  $y_i$ , termed the dual variable is interpreted as a unit opportunity cost, or price associated with a particular activity level  $x_i$ . It is the true implicit value of the resource to the user, expressed in a marginal cost or benefit context.

The system of equations formed through the application of linear programming can be solved through means of the "simplex method." This method is an algebraic technique which progressively approaches the optimal solution through a well-defined iterative process over the  $m$  dimensional convex set formed by the constraint equations. The technique is best performed through a computer software library routine.

Many applications of the above technique to capital planning and scheduling have been developed in transportation planning. It has been effectively used, through some modifications as a capital planning tool, where minimum cost packages of project investment levels have been cast together as the objective function, subject to meeting aggregate service and impact levels (noise, safety, property values, etc.) expressed the constraining equations. Further, the process can be used as a network assignment approach, where  $x_i$  is the level of traffic flow allowable on a link, costed out over all links in the network, subject to constraining equations on meeting travel demand and impact restrictions. Finally, the process can be used to delineate public program levels of activity, wherein each  $x_i$  is a level of effort towards R and D or specific program operating activities, with an objective function to maximize the comprehensive program effectiveness, resulting from such activity, subject to program constraints on cost, safety and reliability or failure rate.

In order to use linear programming effectively, the objective function and every constraint function must be linear. In the real world, linearity may often only be approximated.

Another restriction on linear programming is that fractional or continuous levels of the decision variables  $x_i$  be permissible. Requiring the  $x_i$  to exist as integer numbers, or 0-1 combinations is possible, but renders the computation process, termed integer or mixed-integer programming, much more difficult. It is further assumed in linear programming that all the coefficients ( $a_{ij}$ ,  $b_i$  and  $c_j$ ) are known constants, most often representative as indicators of some future condition. In reality, these coefficients are more accurately represented as random variables. Depending on the complexity of the problem, the opportunity costs, or dual variables may be difficult to interpret in a real-world sense. The items being maximized or minimized in the primal format may be such that no meaningful dual variable interpretation as to marginal cost or benefit may be developed.

Linear programming lends itself well to sensitivity analysis. All constraint and coefficient parameters can be altered efficiently to reflect foreseeable consequences. This allows the analyst to efficiently compare the impact of several levels of all of the decision variables and the range of effectiveness levels ultimately generated.

### Non-Linear Programming

Non-linear programming is a particular application of the linear programming format for allocating scarce resources. In this case, the

linearity restrictions are dropped allowing for more realistic expressions of objective functions and constraints. The general formulation is as follows:

Find  $x_1, x_2, \dots, x_n$  so as to

maximize (minimize)

$$Z = f(x_1, x_2, \dots, x_n)$$

subject to

$$g_1(x_1, x_2, \dots, x_n) \leq b_1$$

$$g_2(x_1, x_2, \dots, x_n) \leq b_2$$

$$\vdots$$

$$g_m(x_1, x_2, \dots, x_n) \leq b_m$$

$$x_j \geq 0 \text{ for } j = 1, 2, \dots, n$$

The functions  $f$  and  $g$  can all be non-linear higher order functions of the decision variables  $x_i$ . Solution procedures for non-linear programming have not been developed to levels of computational efficiency comparable to linear programming. Typically, gradient search approaches, or transformation to a structure which simulates the linear programming process, termed "separable programming" are employed. However, it is useful to note the conditions that must hold in order for an optimal solution to be recognized, these are termed the Kuhn-Tucker conditions:

Assume that  $f(x_1, x_2, \dots, x_n)$ ,  $g_i(x_1, x_2, \dots, x_n)$  ( $i = 1, 2, \dots, m$ ) are differentiable functions, then  $(x_1^*, x_2^*, \dots, x_n^*)$  can be an optimal

solution to the non-linear programming problem only if there exists m number  $u_1, u_2, \dots, u_m$  such that all of the following conditions are satisfied:

$$(1) \text{ If } x_j^* > 0, \text{ then } \frac{\partial f}{\partial x_j} - \sum_{i=1}^m u_i \frac{\partial g_i}{\partial x_j} = 0$$

at  $x_j = x_j^*$  for  $j = 1, 2 \dots n$

$$(2) \text{ If } x_j^* = 0, \text{ then } \frac{\partial f}{\partial x_j} - \sum_{i=1}^m u_i \frac{\partial g_i}{\partial x_j} \leq 0$$

at  $x_j = x_j^*$

$$(3) \text{ If } u_i > 0, \text{ then } g_i(x_1^*, x_2^* \dots x_n^*) - b_i = 0$$

for  $i = 1, 2 \dots m$

$$(4) \text{ If } u_i = 0, \text{ then } g_i(x_1^*, x_2^* \dots x_n^*) - b_i \leq 0$$

for  $i = 1, 2 \dots m$

$$(5) x_j^* \geq 0 \text{ for } j = 1, 2 \dots n$$

$$(6) u_i \geq 0 \text{ for } i = 1, 2 \dots m.$$

$x_j$  is the set of decision variables as in the linear case. The  $u_i$  correspond to dual variables referred to in the previous section, and can be interpreted as such in a cost-effectiveness analysis.

Non-linear programming is discussed herein due to its relevancy to particular aspects of transportation system impacts. Certain user cost optimization problems have non-linear objective functions which lend themselves to study using non-linear programming. Functions with respect to system safety, using accident rates, and accident

costs with respect to optimal provision of system facilities can be cast as non-linear programming problems. It is important to note that the capability to capture the true mathematical nature of the function under study is critical, and non-linear programming can yield some computational and functional structures which are quite difficult to deal with efficiently.

Unfortunately, the Kuhn-Tucker conditions only give clues as to the adequacy of a possible solution. It is impossible to directly derive an optimal result from the Kuhn-Tucker conditions, and computational and structural complexity previously referred to can render solutions difficult to achieve. In some cases, the dynamic programming solution procedures (discussed at another point in the text) can be used to enumerate combinations of the decision variables  $x_i$ , to ultimately solve non-linear problems.

The obvious advantage of non-linear programming, if it can be computationally accommodated, is the capability of dealing with a broad range of phenomena which are not linear in a more adequate manner. Thus, more realism can be developed by non-linear programming structures which capture the true non-linearity of the system cost or impact phenomena under study.

### Goal Programming

Goal programming is also an extension of linear programming. The goal programming approach allows a simultaneous solution of a system of complex objectives rather than a single objective. Goal programming is a technique that is capable of handling decision problems that deal with a single goal having multiple subgoals, as well as problems with

multiple goals having multiple subgoals. In addition, the objective function of a goal programming model may be composed of non-homogeneous units of measure, rather than a single dimension of effectiveness.

Often multiple goals of management and public works achievement are in conflict, and are each achievable only at the expense of some other goals. Furthermore, these goals often appear incommensurable. Thus, solution requires establishment of a hierarchy of importance among these seemingly incompatible goals so that lower order goals are considered only after the higher order goals are satisfied or have reached the point beyond which no further improvements are desired.

The solution of linear programming is limited by quantification capabilities. Unless the decision maker can accurately quantify the relationship of the decision variables in cardinal numbers, true valuation is impossible. Thus, the distinguishing characteristic of goal programming is that it allows for an ordinal solution. That is, management may not be able to specify the exact cost or utility of a goal or subgoal, but often upper or lower bounds on such may be stated for each subgoal. The decision maker then assigns a priority scheme to each subgoal, based on the availability of the resources. The advantage of goal programming is therefore the capability of solution of problems involving multiple conflicting goals according to an established priority scheme.

In mathematical terms, the goal programming structure is as follows:

$$\text{Minimize } Z = d_1^- + d_2^+ + d_3^- + d_4^+ + \dots$$

$$\begin{aligned} \text{subject to } & a_{11}x_{11} + a_{12}x_{12} + a_{13}x_{13} + \dots + a_{1n}x_{1n} = b_1 \\ & \cdot \\ & \cdot \\ & \cdot \\ & \cdot \\ & a_{n1}x_{n1} + a_{n2}x_{n2} + a_{n3}x_{n3} + \dots + a_{nn}x_{nn} = b_n \end{aligned}$$

$$\text{All } x_{ii} \geq 0, d_i^+, d_i^- \geq 0$$

where  $d_i^-$ ,  $d_i^+$  are a goal's negative and positive deviations. The  $x_{ii}$ 's represent a collection of subgoals.  $a_{ij}$  and  $b_j$  represent constraints.

The solution procedure for goal programming is similar to that used in linear programming. The simplex method with only minor additions is used so that the solution procedure is an iterative one and most efficiently solved by employing computer capabilities. Goal programming has value in transportation analysis, as positive impact of transportation investment levels with respect to one goal, such as metropolitan revenue, often has conflicting and negative impacts on another goal, such as minimal air pollution. The capability to adequately represent the judgment and sorting process on goals and determining optimal investments in transportation against a consistent view of such goal structures is a critical real-world decision-making need.

Goal programming has all the inherent liabilities previously discussed with respect to linear programming. However, in goal programming, no longer must the objective function be unidimensional in character. This extension is very useful. Goal programming can also be used when it has been determined that the model coefficients are random variables

having unique probability distributions for the value they take on when the solution is implemented.

The process of establishing a priority scheme on goals can be difficult and appear unrealistic. Adequate judgment amongst all decision makers must be exercised in order to arrive at a reasonable priority structure.

### Dynamic Programming

Another type of backward-seeking model is dynamic programming, which seeks minimum cost or maximum effectiveness solutions.<sup>1</sup> It is a staged, recursive analysis which may be conceptualized thus as shown in Figure 4, where

$n$  = number of stages,  $1, \dots, n$ .

$X_n$  = state of system at  $n$ .

$D_n$  = decision at stage  $n$ .

$r_n$  = return at stage  $n$ .

The objective is to use the following recursion equations:<sup>2</sup>

$$f_n(X_n) = \max_{D_n} Q_n(X_n, D_n), \quad n = 1, \dots, N$$

$$Q_n(X_n, D_n) = r_n(X_n, D_n), \quad n = 1$$

$$Q_n(X_n, D_n) = r_n(X_n, D_n) \circ f_{n-1}(t_n(X_n, D_n)), \quad n = 2, \dots, N$$

---

<sup>1</sup>George L. Nemhauser, Introduction to Dynamic Programming, John Wiley and Sons, Inc., 1966.

<sup>2</sup> $\circ$  is the composition operator which may mean addition, multiplication, or any other compatible operation for the condition.



CONCEPTUALIZATION OF A DYNAMIC  
PROGRAMMING ALGORITHM

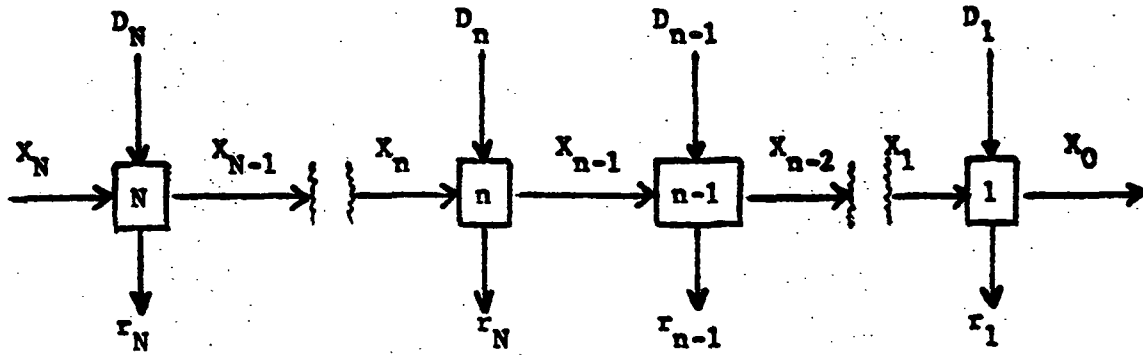

Figure 4.

to develop a staged policy of N decisions, which are optimal, and of which any subset of decisions for appropriate component stages are also optimal.<sup>1</sup> Dynamic programming is important in a computational context, because it may offer a solution to integer programming problems which is extremely more efficient than a total enumeration approach.

Further, dynamic programming is relevant to transportation decisions, as it allows one to capture the optimal manner of synthesis over time, of a series of individual "building block" decisions on investment, system operation, decay levels and compounded impacts, which must, or preferably should be dealt with, in some optimal minimum cost or maximum effectiveness expansion path type of planning and operating programs.

One liability is the size of the dynamic programming problem. As the number of states of the problem increase, the calculation procedures become extremely more complex and costly.

An important strength of the dynamic programming solution procedure is its applicability to classical optimization situations. It can be used to solve some complex non-linear programming problems, and integer and mixed integer linear programming problems. Although the problem structure can accommodate constraints, dynamic programming works most effectively when used as an unconstrained optimization approach, incorporating these constraint functions into the problem as penalty components of the objective function one is attempting to minimize or maximize.

---

<sup>1</sup>This is Bellman's "Principle of Optimality," Dynamic Programming, Princeton University Press, Princeton, New Jersey, 1957.

## Statistical Decision Theory

### Simple Decision Theory

It is relevant to briefly review aspects of simple decision theory as an introduction to the use of statistical decision techniques in transportation systems evaluation.

Simple decision theory can be divided into two general areas, with several distinct techniques under study within each:

1. Decisions Under Risk
  - a. Expected Value Concept.
  - b. Satisficing Concepts.
  - c. Bayesian Decision Theory.
2. Decisions Under Uncertainty
  - a. Equal Value.
  - b. MinMax
  - c. MaxMin
  - d. MaxMax
  - e. Savage Regret.

All of the above techniques in each area will be dealt with except Bayesian Decision Theory. It is felt that Bayesian Decision Theory is a separate subject of great depth, and with alternative algorithmic approaches that have many applications. As such, it will be covered in the subsequent section, and combined with a discussion of sequential sampling. To conceptualize the use of decision theory, we make use of the following matrix:

		J →			
		P(S <sub>1</sub> )	P(S <sub>2</sub> )	P(S <sub>3</sub> )	P(S <sub>4</sub> )
↓ i		S <sub>1</sub>	S <sub>2</sub>	S <sub>3</sub>	S <sub>4</sub>
a <sub>1</sub>		V <sub>11</sub>	V <sub>12</sub>	V <sub>13</sub>	V <sub>14</sub>
a <sub>2</sub>		V <sub>21</sub>	V <sub>22</sub>	V <sub>23</sub>	V <sub>24</sub>
a <sub>3</sub>		V <sub>31</sub>	V <sub>32</sub>	V <sub>33</sub>	V <sub>34</sub>

where:

S<sub>1</sub>...S<sub>4</sub> = The states of the world, or J possible environments under which the decision will obtain.

a<sub>1</sub>...a<sub>3</sub> = the i decision alternatives possible, one of which must be chosen.

P(S<sub>1</sub>)...P(S<sub>4</sub>) = the J probabilities associated with the existence of the corresponding states of the world.

$$\sum_i P(S_i) = 1.0$$

A. Decisions Under Risk:

Definition: A decision under risk is defined as one in which P(S<sub>i</sub>) is known for all S<sub>i</sub>.

Decision Criteria and Techniques

1. Maximize Expected Value:

Here  $\sum_J P_J V_{iJ}$  is computed for all a<sub>i</sub>

then: The alternative a<sub>i</sub>, which  $\text{Max}_{a_i} \sum_J P_J V_{iJ}$

is selected, that is, the alternative is chosen which maximizes expected value.

2. Satisficing Criteria:

Satisficing is choosing an alternative which maximizes the probability of  $V_{iJ} \geq G$ , where  $G$  is some lower bound on acceptable gain, or upper bound on acceptable loss.

Therefore, we proceed as follows:

1. Choose  $G$ , the bound of acceptable gain or loss.
2. For each  $a_i$ , develop  $\sum_J P(U_J)$ , where  $U_J = V_{iJ} \geq G$ , if bound is a gain, or  $\sum_J P(U_J)$  where  $U_J = V_{iJ} \leq G$ , where  $G$  is acceptable loss.
3. Then select  $\text{Max}_{a_i} \sum_J P(U_J)$ .

B. Decisions Under Uncertainty:

Definition: A decision under uncertainty is one where the probability distribution over  $S_J$  is unknown. We then operate with the following decision criteria:

1. MinMax:

- a. for each  $a_i$ , select  $\text{Max } V_{iJ}$
- b. select the minimum of these maximum  $V_{iJ}$ ,  
i.e.,  $\text{Min}_i \text{Max}_J V_{iJ}$

This is normally used where  $V_{iJ}$  represents a loss, and the objective is to render a decision rule or "hedge", which minimizes the maximum loss possible.

2. MaxMin:

- a. for each  $a_i$ , select  $\text{min } V_{iJ}$
- b. select the maximum of these minimum  $V_{iJ}$ ,  
i.e.,  $\text{Max}_i \text{Min}_J V_{iJ}$

This is used where the  $V_{iJ}$  represents a profit or gain, and the objective of a conservative decision maker is to maximize his minimum profits possible.

3. MaxMax:

- a. for each  $a_i$ , select  $\text{Max } V_{iJ}$
- b. select the maximum of the  $\text{Max } V_{iJ}$   
i.e.,  $\text{MaxMax}_{i J} V_{iJ}$

The above is termed the "plunger", or gambler technique, and is always the highest  $V_{iJ}$  in the matrix.

4. Savage Regret:

- a. Assume a particular state of the world,  $S_J$  will exist, call this state  $S_u$ .
- b. For each  $a_i$ , calculate  $R_J = (V_{iJ} - S_u)$  to develop the relative gain or loss for choosing  $a_i$  under a state of the world other than assumed.
- c. Use the MinMax criteria to choose the optimum  $a_i$ , which now minimizes the maximum relative loss.

5. Laplace Equal Value:

- a. Assume  $P(S_i)$  are the same for all  $S_i$ .
- b. Then  $E(a_i) = \sum_J \frac{1}{n} V_{iJ}$ ,  $J = 1, \dots, n$
- c. Choose  $a_i$  which is  $\text{Max}_{a_i} E(a_i)$ .

A self-explanatory set of examples is shown in Table 2.

Bayesian Decision Theory

The basic structure of a Bayesian Decision problem is imposed through the following:

Table 2

Simple Decision Theory Problem Examples

P(S <sub>J</sub> )	.2				.1		.3		.4		Expected Value	Satisfying G <sub>3</sub>	Satisfying G <sub>4</sub>	MinMax <sup>a</sup>	Maximin	MaxMax	Equal Value	Regret, using MinMax criteria <sup>b</sup>
	S <sub>1</sub>	S <sub>2</sub>	S <sub>3</sub>	S <sub>4</sub>	R=	R=	R=	R=										
a <sub>1</sub>	R= -1	R= -2	R= -3	R=0														
	4	3	2	5							3.7	.7	.6	*5	2	5	3.50	-3
a <sub>2</sub>	R= -1	R= -2	R=3	R=0														
	2	1	6	3							3.5	.7	*.7	6	1	6	3	-2
a <sub>3</sub>	R= -1	R=3	R=2	R=0														
	5	9	8	6							*6.7	*1.0	0.0	9	*5	*9	*7	-1*

\* Indicates optimal alternative

a) In this case only, positive elements in matrix = amounts lost.

b) Negative elements equated with R<sub>j</sub> = relative residual loss or "regret".

- 1.)  $\theta_i \in \Theta$ , a series of possible conditions of the system under study, defined as "states of the world" that could occur.
- 2.)  $e_k \in E$ , a group of experiments, of which one or several could be run, in order to yield more information about the true state of the world  $\theta_i$ , above.
- 3.)  $z_j \in Z$ , all possible outcomes associated with an experiment.
- 4.)  $a_\ell \in A$ , a set of alternatives, one or more of which may be chosen in a decision situation.
- 5.)  $U(e, z, a, \theta)$ , a utility, which is a scalar measure representing the relative value to the decision maker of a particular combination of an experiment, an outcome, choosing a particular alternative and having a particular state of the world obtain.

In essence, the evaluation scheme may be looked upon as a game, played over a decision tree, as shown in Figure 5, with the following components:

- 1.) Decision to perform particular experiment.
- 2.) Experiment, prediction, outcome.
- 3.) Decision to choose a particular alternative.
- 4.) Realized utility, a random variable due to  $\theta$ .

Note a decision is made to employ a particular experiment,  $e_k$ , which results in an outcome  $z_j$  that is a random variable. On the basis of the added knowledge about the state of the world and an original assessment, an alternative  $a_\ell$  is chosen, and is executed in the face of  $\theta_i$ , the resulting state of the world, which is also a random variable. The above random outcomes and deterministic choices result in a utility accruing to the decision maker.



Figure 5

ASPECTS OF THE BAYESIAN DECISION PROCESS

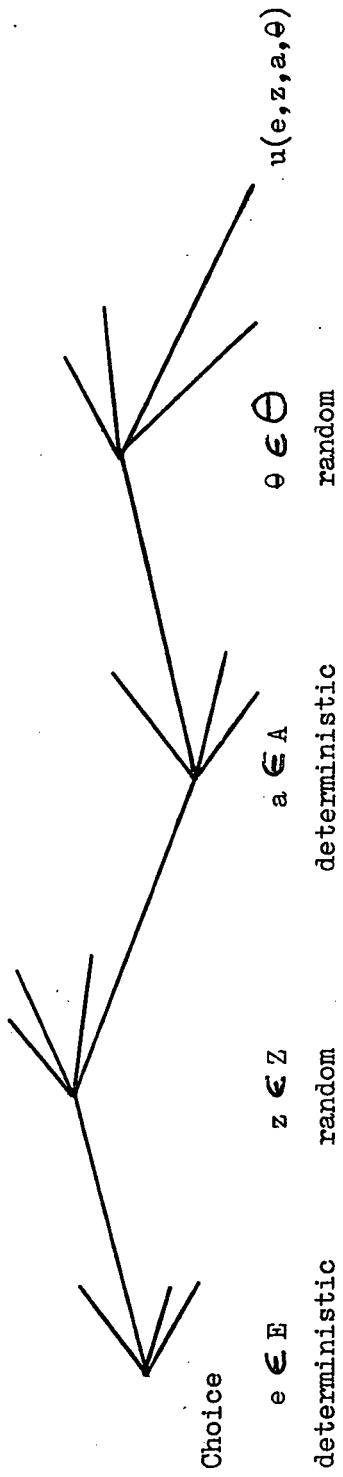

A. Stochastic Inputs in Bayesian Decision Theory

The following information on stochastic aspects of the problem is used in the evaluation:

1.)  $P'(\theta_i)$  = the prior, or marginal measure on the probability of a state of the world  $i$ . This measure is assessed on the basis of a subjective knowledge, or "feel" for the problem, and is prior to the experimentation phase.

2.)  $P(z_j | e_k, \theta_i)$  = the conditional probability of an outcome  $j$  from experiment  $e_k$ , given the true state of the world is  $i$ . This is also assessed prior to undertaking the experimentation.

3.) The joint probability,  $P(\theta_i, z_j | e_k)$ , which =  $P'(\theta_i) \times P(z_j | e_k, \theta_i)$ , and is the probability of occurrence of a particular combination of  $\theta_i$  and  $z_j$  with experiment  $e_k$ .

4.)  $P(z_j | e_k) = \sum_i P(\theta_i, z_j | e_k)$ , which is the marginal probability of an outcome  $z_j$  using experiment  $e_k$ , over all states of the world.

5.)  $P''(\theta_i | z_j, e_k)$  = the revised or posterior probability of state of the world  $i$ , after obtaining outcome  $z_j$  from experiment  $e_k$ . This is obtained through the use of Bayes' Rule, where  $P''(\theta_i | z_j, e_k) =$

$$\frac{P(\theta_i, z_j | e_k)}{\sum_i P(\theta_i, z_j | e_k)} .$$

B. Information Required for Beginning Computation

Three basic methods exist for fulfilling appropriate computations; based on the possible stochastic information, they are:

1.) Joint measures on  $\theta \times Z$  are given, and the marginals and conditional for  $\theta$  and  $Z$  are computed from it, resulting in information to subsequently compute the posterior probabilities.

2.) Marginal, or prior measures for all  $\theta$  are given, and a conditional on Z for every  $\theta_i$  in  $\Theta$  is likewise given. The joint measures, marginals on Z, and posteriors on  $\Theta$  are computed.

3.) Marginals on Z are given, and posterior probabilities on  $\Theta$  are given. The joints are subsequently computed, and ultimately the priors on  $\Theta$  and conditionals on Z.

### C. Alternative Evaluation Schemes

Two alternative types of evaluation may be developed in Bayesian Decision Theory, termed the extensive form, and the normal form. These will be described separately, and subsequently discussed. Description will make use of the decision tree in Figure 6.<sup>1,2,3</sup>

#### 1. Extensive Form

Referring to the decision tree in Figure 6, the following steps are taken.

1.) The expected utility given the selection of any alternative  $a_\ell$  (presuming a particular experiment and outcome precedes selection of this alternative is):

$$U^*(e_k, z_j, a_\ell) = \sum_i (U(e_k, z_j, a_\ell, \theta_i)) \times (P^*(\theta_i | z_j, e_k))$$

in Figure 6, referring to point D, for  $(e_1, z_1, a_1)$ ,  $U^*(e_1, z_1, a_1) = 94(.891) + 7(.109) = 85$ .

---

<sup>1</sup>Howard Raiffa, and Robert Schlaifer, op. cit., pp. 1-22.

<sup>2</sup>Morris H. DeGroot, op. cit., pp. 69-155.

<sup>3</sup>E. K. Morlok, and H. Haack, "Discussion Topic 1, Statistical Decision Theory," class notes from D01-Transportation Systems Evaluation, Winter, 1969.

DECISION TREE

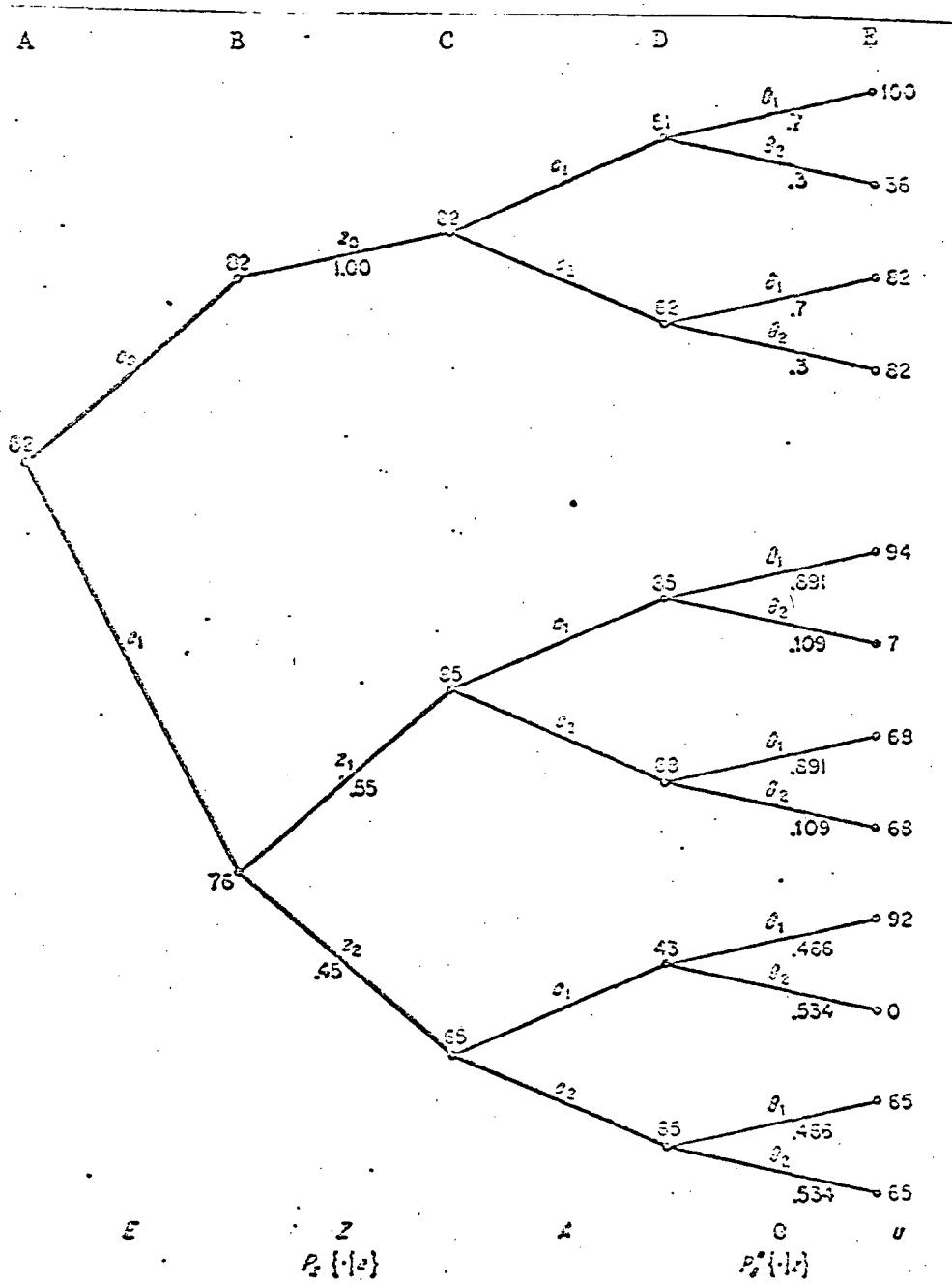

Figure 6

2.) The optimal alternative for each experimental outcome is then selected:

$$U^*(e_k, z_j) = \text{Max}_{a_l} (U^*(e_k, z_j, a_l)) .$$

There is one such value for each  $z$  edge of the decision tree, and is recorded at point C in Figure 6.

3.) The expected value of each experiment is now computed and placed at point B on the tree.

$$U^*(e_k) = \sum_j (U^*(e_k, z_j)) \cdot P(z_j | e_k) .$$

4.) The optimal experiment is thus  $U^* = \max_k U^*(e_k)$ , the maximum expected value corresponds to point A in the tree.

## 2. Normal Form Analysis

To make use of the normal form of analysis, we introduce the concept of a decision rule, which associates an optimal alternative  $a$  with each possible outcome  $z$ . In the normal form, every decision rule for experiment  $e_k$  is considered, and the optimum rule is selected. Each experiment is then evaluated, and the best  $e$  is selected.

As an example of decision rules, returning to Figure 6:

1.) The optimal decision rule  $d^0$  for experiment  $e_1$  is:

$$d_{11} \text{ where } d_{11}(z_1) = a_1 \text{ and } d_{11}(z_2) = a_2 .$$

2.) Non-optimal decision rules for experiment  $s_1$  are:

$$d_{12} \text{ where } d_{12}(z_1) = a_2 \text{ and } d_{12}(z_2) = a_1$$

$$d_{13} \text{ where } d_{13}(z_1) = a_1 \text{ and } d_{13}(z_2) = a_1$$

$$d_{14} \text{ where } d_{14}(z_1) = a_2 \text{ and } d_{14}(z_2) = a_2 .$$

A formalized procedure for finding an optimum  $e$  and  $d(z_j)$  is as follows:

- 1.) Assume that  $e$  and  $d$  are given and that we hold  $\theta$  fixed.
- 2.) Take the expectation of  $U(e, \tilde{z}, d(\tilde{z}), \theta)$  with respect to the conditional measure  $P_{z|e, \theta}$ .
- 3.) The result is

$$U_*(e, d, \theta) = E_{z|e, \theta} U(e, \tilde{z}, d(\tilde{z}), \theta) .$$

Call this the conditional utility of  $(e, d)$  for the given state  $\theta$ .

- 4.) Now expect over  $\tilde{\theta}$  with respect to the unconditional measure,  $P_{\theta}^i$  to obtain:

$$U_*(e, d) = E_{\theta}^i U_*(e, d, \tilde{\theta}) .$$

Call this the unconditional utility of  $(e, d)$ .

- 5.) Next, given any particular experiment  $e$ , choose the decision rule  $d$  whose expected utility is greatest; the utility of any experiment being:

$$U_*(e) = \max_d U_*(e, d) .$$

- 6.) Compute the utility of every experiment  $e$  in  $E$ . Then choose the experiment with the greatest utility.

$$U_* = \max_e U_*(e) = \max_e \max_d E_{\theta}^i E_{z|e, \theta} U(e, \tilde{z}, d(\tilde{z}), \tilde{\theta}) .$$

### 3. Discussion of Normal and Extensive Forms

A comparison of the two forms yields some interesting information. Of primary importance is that the extensive and normal form both yield identical answers as to choice of experiment and action. Ultimately,

both require the same information, however, the normal form allows one to put off subjective analysis of  $P'(\theta_i)$  until the end of the evaluation, and at the outset, makes use of  $P(z_j | e_k, \theta_i)$ , which is a measure that can frequently be assigned from past experience. Alternatively, where it appears best to introduce subjective judgment early in the process, the extensive form can be used.

D. Sequential Sampling

A final characteristic of Bayesian Decision Theory is its ability to allow further information about the problem to be generated, if deemed valuable, prior to action. Such a concept is termed sequential sampling, or sequential experimentation. Its features bear some resemblance to the optimal path problem in network analysis.

As stated before, the analyst has the option of performing one of several experiments, and those experiments can be replicated at any subsequent stage in the process. The assumption is made that each experiment has the same fixed monetary or opportunity cost, which equals  $C$ . Further,  $N$  stages exist at the end of which an alternative must be selected. At any stage the decision-maker has the option of experimenting further, or to use the alternative specified by the decision rule corresponding to the present experimental outcome.<sup>1</sup> This process may be conceptualized as in Figure 7, which shows a network of possible choices throughout the  $N$  stages.

The theorem underlying the selection of the optimal process over  $N$  stages is as follows:<sup>2</sup> For  $j = 1, \dots, N - 1$ , suppose experiment

---

<sup>1</sup>Morris H. DeGroot, op. cit., pp. 267-387 and pp. 429-433.

<sup>2</sup>Paraphrased in part from DeGroot, op. cit., p. 288.

BACKWARDS INDUCTION IN SEQUENTIAL SAMPLING

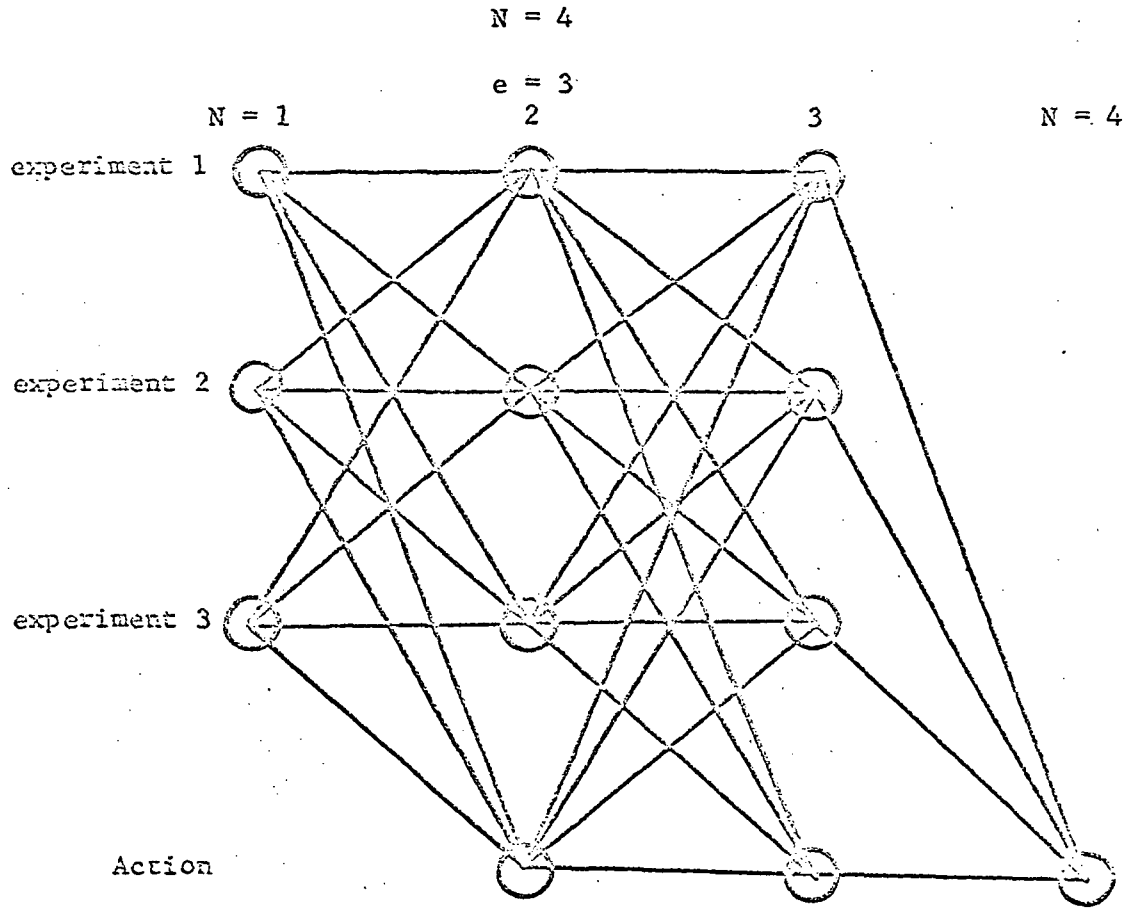

Figure 7



$E_1 = e, \dots, E_j = e$  have been run. If  $U_j^* \leq [(U_{j+1}^*) - C]$ , the additional optimal experiment shall be run at stage  $j + 1$ . If the inequalities are reversed, the action prescribed at  $j$  should be taken.  $U_{j+1}^*$  is computed using the revised probabilities from  $j$  as prior probabilities in  $j+1$ . At stage  $N$ , the action prescribed must be taken.

Looking at Figure 7, one sees that the optimal experiment is selected at stage 1, and by use of the above rule, the optimal choice of action or further experimentation is traced through each succeeding stage, with the network terminating in the action node, at the latest, by stage  $N$ .

#### Markovian Decision Theory

In an analysis of an existing or proposed system from a Markovian framework, the basic concern lies with the trajectory of the process, the sequence of system states, rather than in the time interval between successive states (although this sequence of time intervals can also be considered a random variable). More directly, a system can be described in terms of its state transitions given discrete time intervals. The state variables, such as velocity, rate of flow, etc., themselves capture the dynamics of the system.

The basic assumption of a Markov process lies in the relationships between successive states of the system. With the following notation

$s(n)$  state at time interval  $n$ ,  $n = 1, 2, \dots$

$i, j, k, \dots$  any sequence of states  $1, 2, \dots, N$ .

The assumption has the following formulation:

$$P\{s(n+1) = j | s(n) = i, s(n-1)=k, \dots, s(0) = m\} = P\{s(n+1) = j | s(n) = i\}$$

where  $P$  is a probability measure.

In effect, the system being in state  $j$  at time  $n + 1$  has only to do with the previous state  $i$  and not all previous states of the system from time zero.

The state transition probabilities are the probabilities  $p_{ij}$  of a system in state  $i$  going to state  $j$  in the next time interval. Several assumptions are made to maintain accuracy, but to remove some of the complexity of the model. There is a finite set of states  $1, 2, \dots, N$  of the system which may be occupied at any time. The time interval spacing is assumed constant. Also, the  $p_{ij}$  measures are independent of time and therefore do not change with time or the state of the system. As a probability measure there are two constraints. First, for all  $i, j$ ,

$$0 \leq p_{ij} \leq 1.$$

Second, the probabilities are normalized,

$$\sum_{j=1}^N p_{ij} = 1 \quad i = 1, 2, \dots, N.$$

As a result, the matrix of the transition probabilities,  $N \times N$ , is referred to as a stochastic matrix.

In studying the dynamics of a transportation system, our concern is with the future state of the system given its present state. The multistage transition probability is the probability of a system being in state  $j$  at time  $n$  if it is in state  $i$  at time  $t = 0$ . Notationally, we have

$$\phi_{ij}^{(n+1)} = \sum_{k=1}^N \phi_{ik}^{(n)} p_{kj} \quad n = 0, 1, 2, \dots$$

where

$$\phi_{ij}^{(0)} = \begin{cases} 1 & i=j \\ 0 & i \neq j \end{cases} = \delta_{ij} \quad (\text{kroncker delta}) .$$

These multistage transition probabilities are also a probability measure and are subject to the previously mentioned constraints. For an N state Markov process applicable to a transportation system we have

$$\Phi(n) = \phi_{ij}^{(n)} = \begin{bmatrix} \phi_{11}^{(n)} & \phi_{12}^{(n)} & \dots & \phi_{1n}^{(n)} \\ \phi_{21}^{(n)} & \dots & & \phi_{2n}^{(n)} \\ \vdots & & & \\ \phi_{N1}^{(n)} & \dots & & \phi_{NN}^{(n)} \end{bmatrix} \quad \text{for } n = 0, 1, 2, \dots$$

Mathematically, the following relationship exists

$$\Phi(n+1) = \Phi(n)P$$

where P equals the N x N probability matrix  $p_{ij}$ .

From the  $\phi_{ij}^{(0)} = \delta_{ij}$  relationship

$$\Phi(0) = I$$

where I equals the N x N identity matrix.

Therefore,

$$\Phi(0) = I$$

$$\Phi(1) = IP = P$$

$$\Phi(2) = IP^2 = P^2$$

$$\Phi(n) = P^n \quad \text{where } P^0 = I.$$

As  $n$  becomes large the  $\Phi(n)$  rows approach constants. Therefore, as  $n$  (the number of state transitions) becomes large the probability the system will be in state  $J$  becomes independent of the initial starting state  $i$ . This matrix of limiting values does not mean that as  $n$  becomes large, the system permanently rests in any state  $i$ .

A more complete evaluation picture is developed when the rewards,  $r_{ij}$ , of a state transition from  $i$  to  $j$  are considered in conjunction with the probability structure. The units of the rewards may be any value structure relevant to the problem. The matrix of rewards generated by the Markov process is a random variable with the same probabilistic relations of the Markov process.

$v_i(n)$  is the expected total earnings of the next  $n$  transitions given the system now in state  $i$ . The mathematical relation is as follows where the terms have been previously explained.

$$\begin{aligned} v_i(n) &= \sum_{j=1}^N p_{ij}(r_{ij} + v_j(n-1)) \quad i = 1, 2, \dots, N \\ &= q_i + \sum_{j=1}^N p_{ij}v_j(n-1) \end{aligned}$$

where

$$q_i = \sum_{j=1}^N p_{ij}r_{ij}$$

is the expected immediate reward for state  $i$ .

Alternatives under study may induce different rewards and propensity of state transitions due to the uniqueness of each of the alternatives. Thus, it is typical to have  $k$  matrices of transition probabilities, each referred to as  $P^k$ , and  $k$  reward matrices,  $R^k$ , each associated with the  $k$ th alternative. The above equation on  $q_i$  is

manipulated through a simultaneous equation solution technique termed the Policy Iteration Technique to find:

$$\max_k q_i^k + \sum_{j=1}^N p_{ij}^k v_j$$

for each state  $i$ . Thus an optimum alternative  $k^*$  can be chosen for each state  $i$  the system is in, yielding a composite of them, termed the optimal decision or policy vector

$$d^* = \begin{bmatrix} k_1^* \\ k_2^* \\ \cdot \\ \cdot \\ \cdot \\ k_n^* \end{bmatrix}$$

delineating a complete strategy for all states of the system possible.

#### Relevance of Statistical Decision Concepts

These simple, Bayesian and Markovian Decision tools are highly relevant in emerging transportation systems evaluation research. They allow an optimum seeking approach to be pursued in light of the inherent uncertainty of real-world processes, and in the event environments under which the decisions may be obtained, termed states. Past history, studies, or experimentation may allow the probability distributions of the states and their transitions to be built, along with cataloging the rewards with respect to the impacts of an alternative on a particular state. If one reads the above closely, it is apparent these algorithms closely simulate the real-world process of placing transportation system alternatives in an uncertain set of environments, and probabilistically

accruing several societal, environmental and user impacts, each with associated costs, gains and the propensity for altering the state structure.

### Game Theory

Game theory is a decision process by which some interaction, a game, takes place and is solved between participants who have articulated their strategies prior to the playing of the game. Before a formal description, there are several general terms to be developed. The solution space is dimensioned by the number of unknown variables. These unknown variables can be considered as the participants in the game. The requirements space is determined by the number of constraint equations representing the relationship between the variables. If the dimensions of the solution space are greater than the dimensions of the requirements space, which is generally the case, then there exists a potentially infinite number of solutions. The potential best solution then becomes a problem of maximizing or minimizing some function representing the solution.

There are three principle types of games that are of relevance here. The first is the two-person zero sum game where the benefits accruing to one participant are the exact disbenefits to the other. Two-person open sum games relax this constraint and the game takes on some cooperative aspects. The n-person open sum games are a further extension.

The potential best solution to a two-person zero sum game depends on the function (previously mentioned) to be maximized or minimized. The minimax theorem develops this solution. Generically, by the minimax theorem, a value  $V$  is assigned to every finite game (that is, it will

come to a solution in finite numbers of steps) where  $V$  is the average amount player A can win from B if both follow their strategies. Implicit with this theorem are several assumptions. First, player A will not settle for less than  $V$  while second, player B will not lose more than  $V$ . Next, what B loses, A gains (zero sum property). Finally, A is associated with maximizing his gains ( $X$ ) while B is associated with minimizing his losses ( $Y$ ).

In a more mathematical context, let  $\phi$  represent the payoff function of  $(X, Y)$ . Then define  $\phi_m(y)$  and  $\phi_m(x)$  such that

$$\phi_m(y) = \max_x \phi(x, y)$$

$$\phi_m(x) = \min_y \phi(x, y) .$$

Then the minimax theorem states

$$\text{minimax } \phi = \text{minimum } \phi_m(y) \quad (\text{minimax})$$

$$\text{maximin } \phi = \text{maximum } \phi_m(x) \quad (\text{maximin}) .$$

The significance of these statements will be made clear in a subsequent example.

The game solution consists of determining a saddle point  $(x_0, y_0)$  of the payoff function  $\phi$ . If for  $\phi(x, y)$  there exists some  $(x_0, y_0)$  such that

$$\phi(x_0, y) \geq \phi(x, y_0) \quad \text{for all } x \in X, y \in Y$$

then  $(x_0, y_0)$  is the solution. If the game has a solution then

$$\text{minimax } \phi = \text{maximin } \phi .$$

Inherent in the concept of game theory are two additional assumptions: First, the first player to move cannot win the game on the initial move without the second player's participation. Second, the first player will not be forced to lose initially.

An example of the implementation of a two-person zero sum game can be seen in the following matrix in Figure 8. Player A knows B's wish to minimize his loss. Therefore, A looks for the maxima of row minima, maximin. Player B, on the other hand, knowing A's strategy,

		$B_1$	$B_2$	Row
		$s_1$	$s_2$	Minimum
A	$A_1$	$a_{11} = 3$	$a_{12} = 2$	2*
	$A_2$	$a_{21} = 2$	$a_{22} = 1$	1
Column		3	2*	
Maximum				

where  $s_1, s_2, s_1, s_2$ , are the various player strategies  
(pure strategies)

$a_{11}, a_{12}, a_{21}, a_{22}$  are the values associated with the  
respective strategy selections

Figure 8. PAYOFF MATRIX

wants the minimum of column maxima, minimax. The solution payoff is equal to the game value, which is two in this case. This saddle point is the solution payoff, which equals the game value.

When no saddle point exists, the game outcome is determined through mixed strategies. Mixed strategies are a combination of pure strategies with a given frequency. It can be considered as a strategy selection through a random process.



The game is considered to exist in a normal form when the entire sequence of decisions for the game is made at one time when a choice of strategy is made. The extensive form is where decisions are made one at a time during the course of the game.

The first refinement of this game is the two-person non-zero sum game. In this case, the outcome is determined by a set composed entirely of competitive elements. A second refinement, the cooperative game, is solved by coordination of player efforts in order to achieve the common interests. Here, the concern is with the degree of cooperation between player A and B where mixed motives of action are involved.

Similar to the first example, the following is a payoff matrix, Figure 9, where both receive some benefit. Here, the first payoff

		B	
		B <sub>1</sub> s	B <sub>2</sub> s
A	A <sub>1</sub> s	(0,0)	(10,5)
	A <sub>2</sub> s	(5,10)	(0,0)

Figure 9. PAYOFF MATRIX

in parenthesis is the payoff to A while the second is the payoff to B. Both players have a common interest in averting the zero value payoff. The conflict arises over who receives the 5 and 10 payoffs. The extent of player communication could have a profound effect upon the game.

Another extension of the basic two-person game is the n person, open sum game. In this game format, cooperation among several individuals

or groups of players exist. Here, the power of players exists through coalition. The minimum payoff a player can receive is that minimum he will get if the others do not cooperate. The concept of potential power is introduced where a player may participate in a coalition to further raise his benefits.

The three actor example, pictured in Figure 10, is a simple

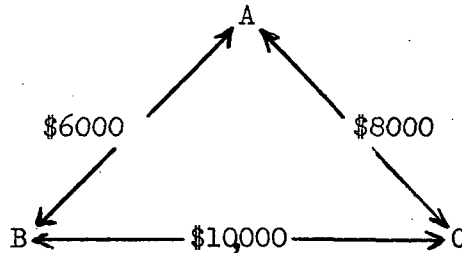

Figure 10. THREE ACTOR SAMPLE

representation of an n-person game. In this situation, there are a number of possible coalitions and alternatives available. At first glance, B and C would join since they have the most to gain. Realizing this, one or the other may try to join with A by extracting a higher proportion of the benefits from A. Player A obviously would rather join a coalition than stand alone and get nothing.

A solution to this game is achievable by the application of the Aumann-Maschler theory. This theory does not predict what, if any, coalition will form, but rather what a player can expect if a coalition forms. This predicted value is based upon player strength and is independent of the actual coalition formed. The concepts of equity also do not apply. In the above example, the expected returns are

A	\$2000
B	\$4000
C	\$6000 .

The determination of the payoffs is an iterative process where all one-person coalitions are assumed to have zero value, the sum of benefits equals the value of the coalition, and no player shall receive a negative payoff.

The above competitive decision models, popularly termed "game theory," are conceptually relevant attempts to capture the structure of conflict and citizen values inherent in the transportation system location and design process, and the struggle between subgroups to promote the alteration of locations and designs when they are affected adversely by them. It is presented here for its underlying logic fit in the transport decision process, and for its insight in structuring groups' and community strategies on projects having a significant set of public impacts.

In the above context, each group assesses several location alternatives and pressures for acceptance of them to a greater or lesser extent, depending on their value structure, and pressure being exerted for each of the alternatives by the other groups of the community. Conceptual solutions to the structures where possible, yield a relative measure of pressure or support each group involved in the location process should attach to each alternative to minimize their losses, in light of similar maneuvering of emphasis by other groups. Under the current planning process, such offering of support or pressure occurs through the public hearing process, appropriate planning or public works commission meetings,

or in informal articulation of the group's point of view to responsible professional and public officials.

The one immensely significant advantage of this technique, in spite of its mathematical and computational complexity, is its ability to adequately structure the citizen's group political and public hearing process, and the underlying community power struggle in location decisions, as well as in the final implementation and construction phases. It alone captures the group interaction, compromise, acceptance and/or rejection of plans in the public hearing process, and the emphasis which groups attach to various transportation proposals. As a practical logic framework for the resolution of locational conflicts and insight to forces behind implementation of system construction, it can be an excellent tool.

#### Forward-Seeking Models

It is not possible to discuss forward-seeking models with the degree of specification existent when discussing the several definite algorithmic forms available in backward-seeking approaches. In essence, any generalized procedure which predicts consequences of an alternative, develops a figure of merit, uses this to evaluate the alternative, and compares the results to that desired in the real world is a forward-seeking model. Aspects of engineering-economic models in Chapter II are forward seeking. In addition, the logic routine incorporated in typical simulation processes is forward seeking. The accompanying Figures 11 and 12 show an excellent example of a forward-seeking structure in a transportation safety problem, and the simulation modelling logic built to accommodate it. Figure 11 shows

Figure 11

GENERATED FORWARD-SEEKING APPROACH  
IN THE HIGHWAY SAFETY PROBLEM

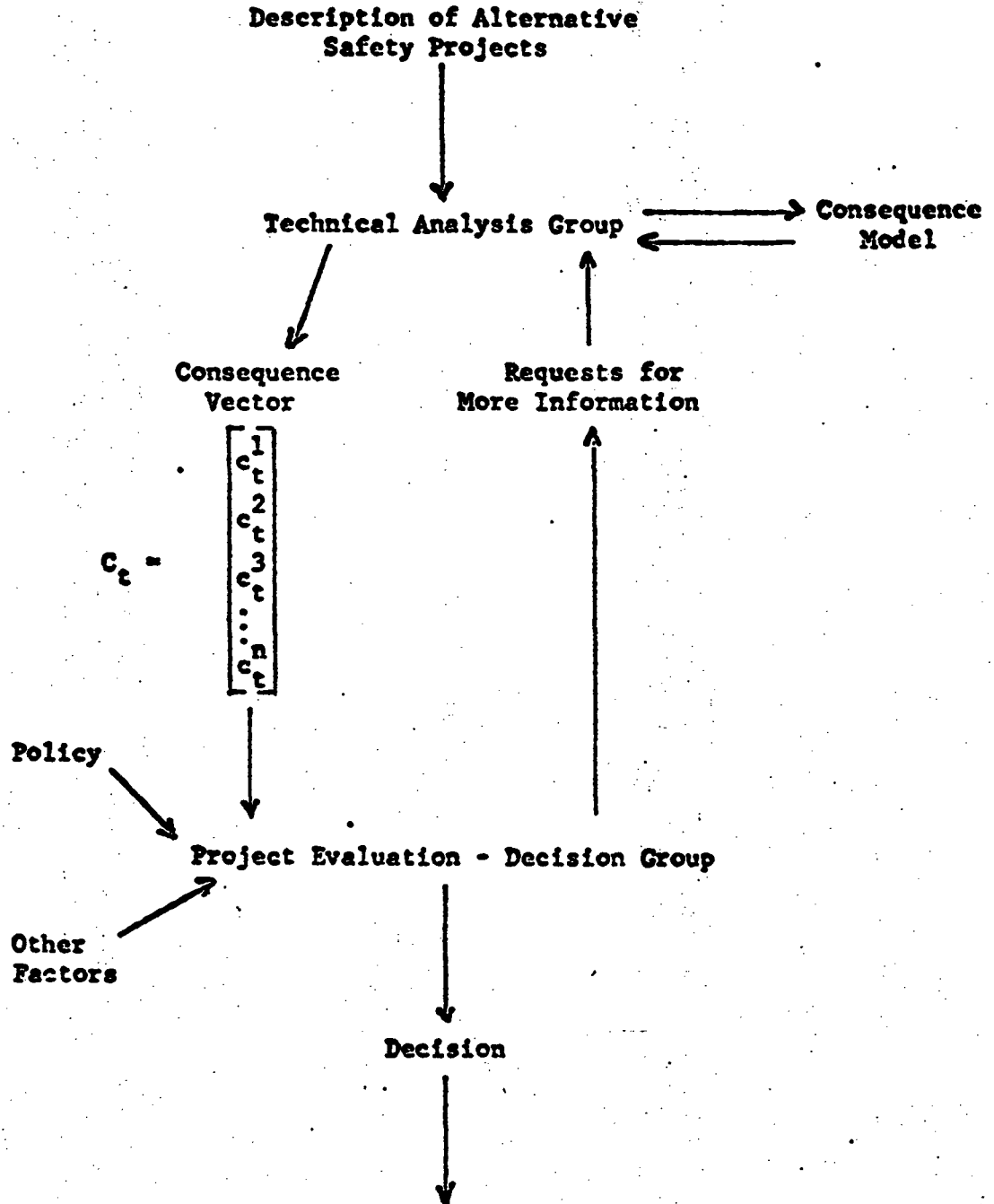
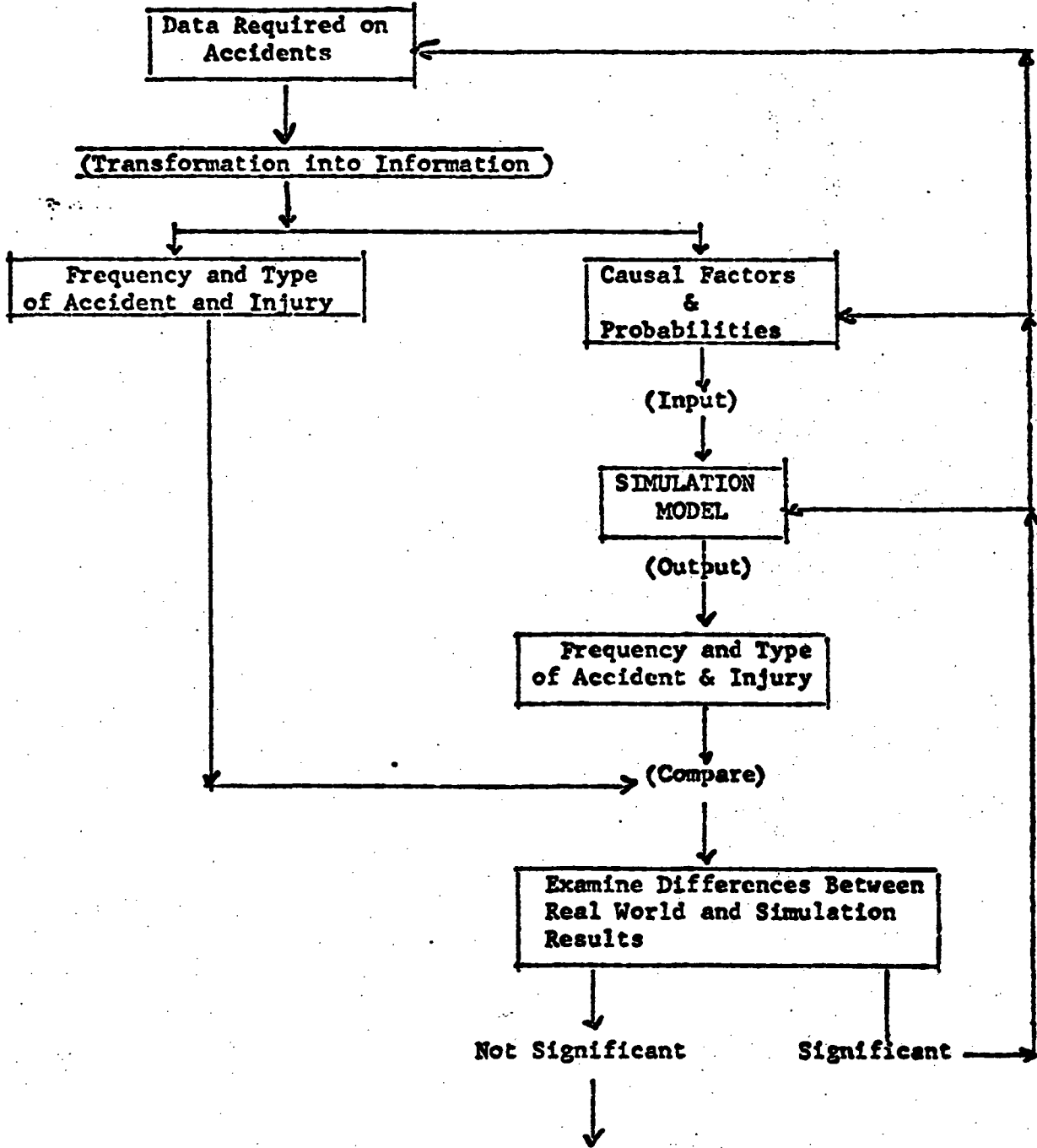

Figure 12

USE OF SIMULATION  
IN MODELLING HIGHWAY SAFETY PROCESSES



the general forward-seeking context of description of the alternative, forecasting of its consequences, comparison to decision criteria, and the potential for reiteration. Figure 12 assimilates this in a simulation modelling context of data, transformation, development of relevant frequencies and examination of differences between simulated and actual performance of the system.

Simulation is an important tool in transportation systems where the process is so complex it cannot be adequately patterned through goal-directed algorithms. It is typically used to study systems operation, or to examine certain system attributes which cannot be expeditiously conceived on the real system, such as safety or reliability failures. Its inherent disadvantage is its somewhat structureless format, and the modelling and software development and execution costs.

## CHAPTER IV - SIMPLE AND HUERISTIC COST-EFFECTIVENESS APPROACHES

### Introduction

The techniques discussed in this chapter are extremely rudimentary non-monetary evaluation techniques which could be currently operational for use by current agencies. With the exception of the desirability rating approach, they attempt to capture inherent, obvious facts about the specific evaluation problem, and organize those facts in a pragmatic short-cut decision context. Desirability ratings (utility theory), though truly more complicated than the rest, is included herein as a natural extension of the accompanying approaches.

### Ranking Method

The simplest of the numerical techniques which can be used to compare alternate transportation system modifications is the ranking method. In using this procedure, each alternative is ranked with respect to its ability to satisfy the social, environmental and economic factors under consideration. As shown in Table 3, the effects of the improvement

TABLE 3: Example Ranking of Alternatives  
vs. Dwelling Units Destroyed

Alternative	Dwelling Units Destroyed	Rank
V	0	1
W	2	2
X	20	3
Y	24	4

are rank-ordered, a rank of 1 is assigned to the alternative which best satisfied a particular factor, and a rank of n (where n



equals the number of alternatives) is assigned to the alternative which is least desirable with respect to the factor.

For impacts which are quantifiable (e.g., number of dwelling units destroyed) the procedure is easily applied. For nonquantifiable factors (e.g., effects on wildlife protection), a rank is assigned by applying judgment on the basis of a pairwise comparison of the alternatives. In either case, the data requirements correspond to the minimum level required for other numerical methods, and only consistency rather than precision of the data is necessary.

The most prominent disadvantage of the ranking method is its nonlinearity, which fails to distinguish incremental differences among alternatives. This nonlinearity, coupled with the fact that the factors under consideration may not all be of equal importance, generally precludes the analyst from reaching a decision on the basis of rank summation. In the typical case, as shown in Table 4, no alternative will

**TABLE 4: Ranking Example for Five Alternatives and Seven Factors**

Socio-Environmental Factor	Alternatives				
	#1	#2	#3	#4	#5
A	5	3	1	2	4
B	1	3	4.5	4.5	2
C	4	3	1	2	5
D	2	3	5	4	1
E	3	3	1	5	3
F	5	3	4	1	2
G	1	3	5	2	4

show a clear superiority to all others. This is a reflection of the fact that each alternative was chosen for consideration in the decision-making process because it is superior to other alternatives with respect to at least one of the factors under consideration. As a result, it is frequently not possible to select the best alternative by the ranking method.

The ranking method is useful in the evaluation of minor projects where the null alternative is environmentally undesirable, and in the screening of an unusually large number of projects for the purpose of deleting from consideration those projects which consistently rank poorly.

#### Rating Methods

Two of the inherent deficiencies of the ranking procedure, the nonlinearity of the scale and the varying levels of importance of the factors under consideration can be remedied, either individually or collectively, through the use of a weighting scheme. Such schemes, in which the alternatives and/or the impact factors are related to an arbitrary weighting scale, are referred to as rating methods. Specifically, one of the following methodologies is employed:

- 1.) The impact factors are weighted according to their relative importance to the community, for example, noise abatement may be considered of more importance than preservation of open space;
- 2.) An arbitrary rating scale is established whereby the impacts may be compared in a consistent and linear manner. With respect to land values, a possible rating scheme would be:

50% increase in value	rating = 1
10% increase in value	4
30% decrease in value	7

These methods solve two of the principal disadvantages of the ranking procedure. If both weighting schemes are used, as shown in Table 5, it is possible to reach a decision by summing the ratings for each alternative. (The highest or the lowest summation will be the most desirable, depending upon the weighting convention used). An additional benefit is that impacts of comparatively minor importance can be appropriately weighted and included in the analysis.

TABLE 5: Rating Example  
Alternatives

Factor	#1	#2	#3	#4	#5
A	9	5	1	4	7
B	2	5	6	6	3
C	6	3	1	2	7
D	3	6	9	8	1
E	4	4	1	7	4
F	9	5	6	3	4
G	2	4	7	3	6
Summation	35	32	31	33	32

The increase in realism achieved with these methods comes at the expense of time and money. This expense is reflected in the increased level of effort which must be expended to insure that the data is accurate and the additional steps required in the analysis phases. Achieving homogeneity of scales used in the rating of alternatives

adds a minor complication. On the other hand, a consensus with respect to value judgments employed in factor rating is frequently difficult to obtain. A universal factor rating scheme cannot be developed because of differences in community values.

The additional effort required by the rating methods is usually worthwhile on major projects, and has been shown to work satisfactorily when a representative citizen's advisory group is consulted in establishment of the rating system.

#### Rank-Based Expected Value

An interesting modification of the ranking method results in the rank-based expected value technique. Both the factors to be considered in the location and design, and the alternative locations or designs are ranked. The former are ranked according to their relative degree of importance, while the alternatives are ranked in the order of their effect on the factors. Application of this method in Wisconsin, illustrated in Table 6, involved the following steps:<sup>1</sup>

- 1.) The ranking of all plan objectives (or factors),  $n$  in number, in order of importance and assignment of values of  $n, n - 1, n - 2, \dots$ , to  $[n - (n - 1)]$  in descending rank order.
- 2.) The rank ordering of plans (or alternatives),  $m$  in number under each objective (or factor) and assignment of a value  $m, m - 1, m - 2, \dots$ , to  $[m - (m - 1)]$  .

---

<sup>1</sup>Southeastern Wisconsin Regional Planning Commission, Forecasts and Alternative Plans 1990, Vol. II.

TABLE 6: Rank-Based Expected Value Example  
Plan

	1	2	3	4	5
Probability of Implementation	.7	.6	.8	.9	.5
Rank Order Value of Each Plan Objective					
A. Market Access Rank order = 7	5	3	4	2	1
B. Level of Service Rank order = 3	4	3	5	2	1
C. Provision of Public Services Rank order = 2	4	3	5	2	1
D. Disruption Rank order = 4	1	3	4	2	5
E. User Costs Rank order = 5	1	3	2	3	5
F. Noise Pollution Rank order = 1	5	3	3	4	1
G. Others Rank order = 6	4	3	5	1	2
Plan Value	65.1	50.4	89.6	51.3	35.0

- 3.) The estimation and assignment of a probability of implementation for each alternative.
- 4.) The score or value of each alternative is obtained by multiplying the rank of the objective (factor) times the rank of the alternative (and multiplying times

the probability, if used) and summing the products for each alternative. For example, the score of alternative  $i$ , can be expressed as follows:

$$V_i = P_i (n_1 m_1 + n_2 m_2 + \dots + n_n m_n)$$

where  $V_i$  = score of alternative  $i$

$P_i$  = probability of implementing alternative  $i$

$n_1$  = the rank for factor number one

$m_1$  = the rank for plan  $m$  for factor number one

One of the major advantages of the rank-based expected value method of considering social and environmental factors in evaluating transportation system location and design alternatives is its ease in application. The objectives must be rank ordered and the rank value of each alternative for each objective must be determined. However, this is easier to do on a relative basis than on an absolute value scale. For small scale decision situations (i.e., comparison of project alternatives), changes in ranking to test for sensitivity would be feasible. On the other hand, system-wide alternatives would be too large for this to be practical and the development and use of a computer program for sensitivity analysis would be necessary. This technique has been well discussed in the literature.<sup>1,2,3,4</sup>

---

<sup>1</sup>Gendell, D. S., "Evaluation of Alternative Transportation Systems," unpublished lecture notes from FHWA Urban Transportation Planning Course.

<sup>2</sup>Hillegass, T. J., C. C. Schimpler and W. L. Grecco, "Community Decision Structure and Urban Planning Process," American Society of Civil Engineers, Journal of Urban Planning and Development, Vol. 96, No. 1, March, 1970, pp. 17-26.

<sup>3</sup>Schlager, K., "The Rank-Based Expected Value Method of Plan Evaluation," Highway Research Board, Research Record 238, pp. 153-156.

<sup>4</sup>Strum, B. D., "Discussion of the Community Structure and Values Approach," Highway Research Board, Research Record 238, pp. 156-158.

Plan 3 has the highest value and is thus the best plan. In this example the probability of implementation was arbitrarily established, but in practice it should be established on the basis of the likelihood of the plan or project actually being accomplished.

### Value Matrix

A technique similar to the rank-based expected value method is one that has been used by Jessiman, et. al.<sup>1</sup> and by Schimpler and Grecco,<sup>2</sup> which is categorized as the value matrix method. Instead of ranking the factors according to their degree of importance, they are weighed with the most important receiving the highest weight. Then the previously described rating technique (or a relative rating scale or utility curve) is used to rate the alternatives to show their effect on the factors. The value or score of an alternative is obtained by multiplying the weight of each factor times the rating of the alternative for that factor and summing.

As presented by Jessiman, et. al., and illustrated in Table 7, this technique involves the following steps:

- 1.) Define and itemize the community objectives in provision of the transportation facility being considered.

---

<sup>1</sup>Jessiman, W., et. al., "A Rational Decision-Making Technique for Transportation Planning," Highway Research Board, Research Record 180, pp. 71-80.

<sup>2</sup>Schimpler, C. C. and W. L. Grecco, "Systems Evaluation: An Approach Based on Community Structure and Values," Highway Research Board, Research Record 238, pp. 123-152.

TABLE 7. Example of Value Matrix Application  
Alternative

Objective	#1		#2		#3		#4		#5	
	Measure	Points	Measure	Points	Measure	Points	Measure	Points	Measure	Points
A. Market Access (Avg. time to County center)	12 Min.	20	16	10	15	7.5	19	2.5	20	0
B. Level of Service (Avg. travel speed)	38 Mph.	5.3	40	6.7	42	8	30	0	45	10
C. Provision of Public Service (Police response time)	8 Min.	5	9	2.5	6	10	10	0	9	2.5
D. Disruption (No. of homes taken)	40	0	14	10.8	12	11.7	4	15	20	8.3
E. User Costs (Annual dollars in millions)	1.6	0	1.1	9.4	1.2	7.5	.8	15	1.0	11.2
F. Noise Pollution (db at 100 ft.)	50	10	65	4	60	6	70	8	75	0
G. Others (Rank by Engin. judgment)	2	5	3	10	4	15	1	0	5	20
<b>Total Points</b>		<b>45.3</b>		<b>53.4</b>		<b>65.7</b>		<b>40.5</b>		<b>52.0</b>



- 2.) Determine the parameter which best measures each objective. Some suggested measures are indicated for the objectives listed for the ranking method.
- 3.) Assign a weight (or utility value) to each objective to reflect community values (which might vary from one local community to another).
- 4.) Study the parameter chosen to measure each objective and determine the value for each alternative. If this is done on a weighting basis, the alternative that best meets that objective would receive the highest weight (or full number of points), the alternative that is next best in meeting the objective would receive the second highest weight and so on until the worst alternative (with respect to that objective) would receive the least weight (possibly no points).
- 5.) Select the best alternative—This technique would select the alternative with the highest value as best meeting that particular combined set of objectives shown in Table 7 as alternative 3.

Jessiman, et. al.<sup>1</sup> also discuss the use of utility curves or the combination of utility curves and relative rating (the former for some objectives and the latter for others) in steps 3 and 4 above.

---

<sup>1</sup>Jessiman, et. al., Op. cit.

In fact, one significant advantage of this technique is its ability, in a systematic framework, to handle a mixture of both subjective measures and values from rigorous mathematical techniques.

Schimpler and Grecco suggest some modifications in using the value matrix technique. The major change is in establishing weighted community decision criteria by community decision makers and professional planners acting as the criteria evaluation group or committee. The procedures involved are:<sup>1</sup>

- 1.) Professional planners establish a tentative set of community goals, explicitly stated.
- 2.) The criteria evaluation group meet for general discussion and modification of each item in the community goals statements, resulting in a complete statement of community objectives, modified in view of the comments of the decision makers or criteria evaluation group.
- 3.) Each member of the criteria evaluation group individually weighs the various sets of criteria by either ranking or rating.
- 4.) The criteria evaluation group meets and are asked to re-evaluate these initial weighting of each criteria element.

---

<sup>1</sup>Schimpler, Op. cit.

Desirability Ratings (Utility Theory)

The general results of attaining a value of an alternative will continue to be manipulated throughout this document in a variety of evaluation formats. This section seeks to underly these through a somewhat formal discussion of arriving at a "desirability level" valuation of an alternative. In so doing, it makes use of some of the formal mathematical attributes of "utility theory," which attempts to measure the worth or value of a set of alternatives or objects to an individual or a group.

Simply speaking, the desirability of a transportation system design or location is one's measure of its worth to him. That is, for location and design alternative X, we associate a value,  $V_x$ , which may be in dollars, a value or a scale from 0-100, or any other arbitrary scale consistent with the individual's point of view. This method, as an input to other evaluation techniques, seeks to describe such possibilities of arrival at reasonable scales, which are:

- 1.) Location X has several impacts  $1, \dots, n$  (such as capacity alteration, change in accident rate, homes taken, businesses taken, pollution emissions, etc.). The decision maker associates a set of consistent values  $V_{x1}, V_{x2}, \dots, V_{xn}$  with these  $n$  impacts. Then the utility or worth of location X,  $U(X) = V_{x1} + V_{x2} + \dots + V_{xn}$ , which is the sum of the individual values. That is, the utility structure is additive, yielding a final value for the project.

- 2.) Using the same example,  $U(X) = V_{x1} \cdot V_{x2} \cdot V_{x3} \cdot \dots \cdot V_{xn}$ , which is the product of the several individual values associated with the several impacts. That is, the utility structure is multiplicative, compounding over the several values attached to individual impacts.
- 3.) If the several 1, ..., n impacts are uncertain, and there exists  $P_1, P_2, \dots, P_n$ , where  $P_i$  is the percentage chance that a particular individual impact  $i$  will occur, the utility structure may be  $U(X) = P_1 V_{x1} + P_2 V_{x2} + \dots + P_n V_{xn}$ , yielding a final "expected value" of location.
- 4.) Finally, in general,  $U(X) = f(V_{x1}, \dots, V_{xn})$ , that is,  $U(X)$  may be some complex mathematical function of the several individual values, involving addition, subtraction, multiplication, division or powers.
- 5.) General transitivity of the utilities of several alternatives is assumed, that is, if the value of location  $X$  is greater than the value of location  $Y$ , and the value of location  $Y$  is greater than the value of location  $Z$ , then the value of location  $X$  is greater than the value of location  $Z$ .

Advantages:

- 1.) It has the ability to develop an abstract measurement scale which is relevant to the concerned group's points of view, and in so doing allows the combining of the valuation of several independent results of location, into simple or complex functional mathematical forms, as required.
- 2.) As such, it broadens and moves away from the traditional strict monetary evaluation process.
- 3.) It allows the combination and inclusion of information about uncertainty of impacts into the evaluation process.
- 4.) It forms a usable and common input into several currently used evaluation techniques.

Shortcomings:

- 1.) Assessment of the values of the impacts associated with a location (i.e.,  $V_{x1}, \dots, V_{xm}$ ) is often difficult for each concerned group.
- 2.) Likewise, assessment of the chances of each impact occurring,  $(P_1, \dots, P_n)$  is often difficult.

3.) Finally, most difficult if (1) and (2) have been overcome, is to approximate the appropriate value or utility function of the alternative; that is, is it additive, an expected value, multiplicative, or some complex functional form, and what are its units, e.g., dollars, lives lost, or some final level on a preselected scale whose values range from a lower bound to an upper bound.

In conclusion, the technique in determining basic value, or desirability of a location has much merit in discovering the underlying value structure and broadening the evaluation format. However, efficient use in light of its shortcomings should emphasize simple, readily identifiable functional forms of  $V(X)$ , logically relatable to the points of view of the concerned groups. Complex functional forms should only be used where a very great amount of certainty exists that the mathematical statement is in fact correct and meaningful in relation to the location process and the groups concerned.

## CHAPTER V - APPROACHES EMPLOYING WELFARE ECONOMICS

### Introduction-Transportation and Equity

Activities that need efficient linkage with other activities collect in cities. Therefore, it is the nature of urban residents to both cluster together in neighborhoods and to travel rather continuously about and between their cities. The objectives of any type of planning are to improve the environmental qualities of a city's individual neighborhoods and to improve all aspects of their efficiency of their transportation supply.

While all urban public investments have the singular goal of improving the quality of the city and the region, within that goal are multiple objectives differently valued by different neighborhoods and by different sectors of the public. Therefore all public investment decisions are political by definition.

Public investment decisions must be politic - and for other reasons - they must also be "fair". Therefore technological solutions worthy of consideration should only be those which establish a Pareto Optimality of sorts, where the proposed solution harms no neighborhood or other interest group and helps all to achieve one or several objectives. That this synthetic optimum can be approached but never attained does not compromise its importance.

Public investment decisions that aim for such Optimality must be approached from two directions:

- 1.) All interest groups and their objectives on which alternative investments will impinge must be identified;

all systems performance criteria (or standards) must be identified and the extent to which each alternative satisfies such criteria will be described; the importance of each set of criteria to each interest group will be assessed.

2.) The costs to society of each alternative will be determined.

Some conceptual analysis of the above two points reveals several pertinent patterns of behavior in current public works decision making:

As stated in the previous chapter in dealing with desirability ratings, a "value structure" for each individual interest group exists, representing various weights they put on objectives likely to be affected by the implementation of a facility or technology. This value structure may incorporate some dimensions which are costed in monetary terms, however it normally weights other "intangible" measures of value or cost which have no such identifiable measurement output. The result of this is, theoretically, to develop an n dimensional utility or preference function which represents the group's appropriately weighted reaction to the facility presented. The weightings, though subtle and complicated, are authentic, and are articulated across the forums of discussion, conflict, hearings, compromises and tradeoffs which are the bargaining efforts of the groups to settle on a facility or technology which allow Pareto Optimality to exist.

A serious problem for the technical analyst here is that good operational analytical methods are not frequently employed for simultaneously examining these preference functions and the dynamics of conflict which occur in the negotiation towards settling on a technology or facility satisfying requirements of Pareto Optimality.



Emerging research techniques of game theory and desirability ratings have been referenced in previous chapters. The setting for public participation in transportation investment decisions should be geared towards reaching a quasi-Pareto Optimality, and it is the function of technicians to provide whatever insights they can for all interest groups in these negotiations.

### Concepts from Welfare Economics

The realm of elementary welfare economics lends itself well to an all encompassing analysis approach to benefits and costs due to transportation systems modification. We shall articulate some of the basic concepts of welfare economics, and discuss how they are to be formulated in a modelling context.

Several basic criteria exist in welfare economics for judging the merits of an improvement.<sup>1</sup> They are:

Pareto Criterion: which states, a change which harms no one and which makes some people better off must be considered to be an improvement.

Kaldor Criterion: The criterion asks how much one group is willing to pay to be better off. If that amount is greater than the amount another group loses, then the move is considered an improvement. Thus the gainer can compensate this latter group, and still have a surplus. Kaldor does not actually require that the group incurring losses be compensated, only that the gainer be potentially able to make such compensation. In short, the Kaldor criterion states gains must outweigh losses.

---

<sup>1</sup>Baumol, W. J., Economic Theory and Operations Analysis, pp. 375-381.

Scitovsky Criterion: This criterion states that:

a.) One should use the Kaldor Criterion to see if the move is initially an improvement.

b.) Use the Kaldor Criterion to see if the move back from the changed state is not an improvement. The change of state must pass both tests to be classed as an improvement.

Example Problem

For the sake of illustrating this somewhat elusive but significant technique, a detailed example with respect to simple rural highway design is presented as a concluding section of this chapter.

Formal Assumptions

The problem is formally stated as follows: given, an original road network with eight nodes and travel conditions as shown in Figure 13. A freeway is overlaid over one of the central routes, reducing travel time and accident potential as shown in Figure 14. Two interchanges are located at A and D. This analysis centers on the question of what configurations of freeway and crossroad interconnection benefit or inconvenience groups of users or non-users.

The following assumptions are made, as seen in Figure 14.

- 1.) Excess capacity exists at the interchanges.
- 2.) The system is uncongested.
- 3.) A 30 MPH uniform speed limit over all local roads exists.
- 4.) A 60 MPH freeway speed limit exists.
- 5.) The following volumes - by node - originate and terminate daily:

Figure 13

Original Road Network Travel Conditions

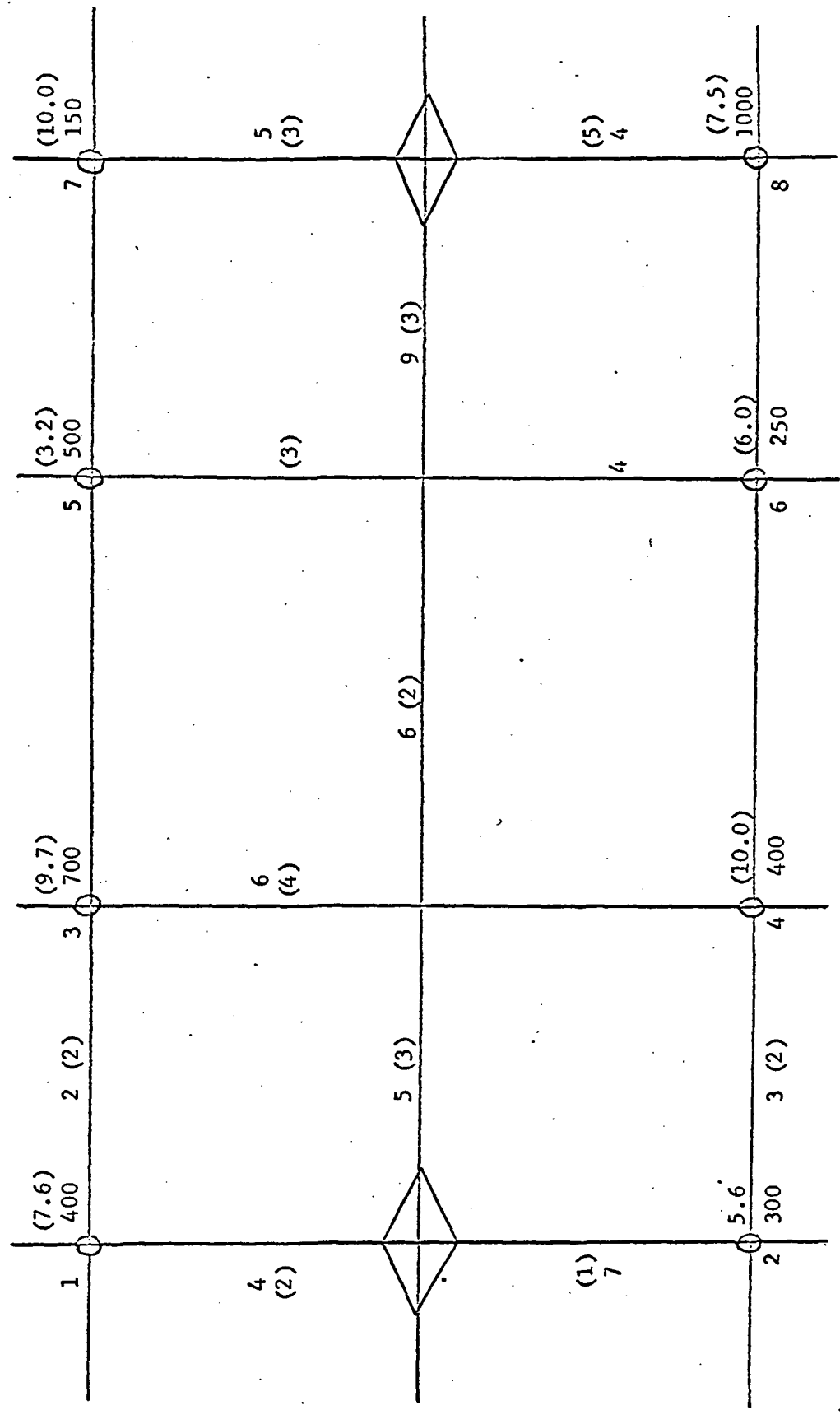

Legend: Mean Annual Income (ADI) 400  
 Accident Rating 7.6  
 Mean Annual Income (ADI) 300  
 Accident Rating 5.6  
 Mean Annual Income (ADI) 700  
 Accident Rating 9.7  
 Mean Annual Income (ADI) 400  
 Accident Rating 10.0  
 Mean Annual Income (ADI) 500  
 Accident Rating 3.2  
 Mean Annual Income (ADI) 250  
 Accident Rating 6.0  
 Mean Annual Income (ADI) 150  
 Accident Rating 10.0  
 Mean Annual Income (ADI) 1000  
 Accident Rating 7.5

Figure 14

Freeway Travel Conditions

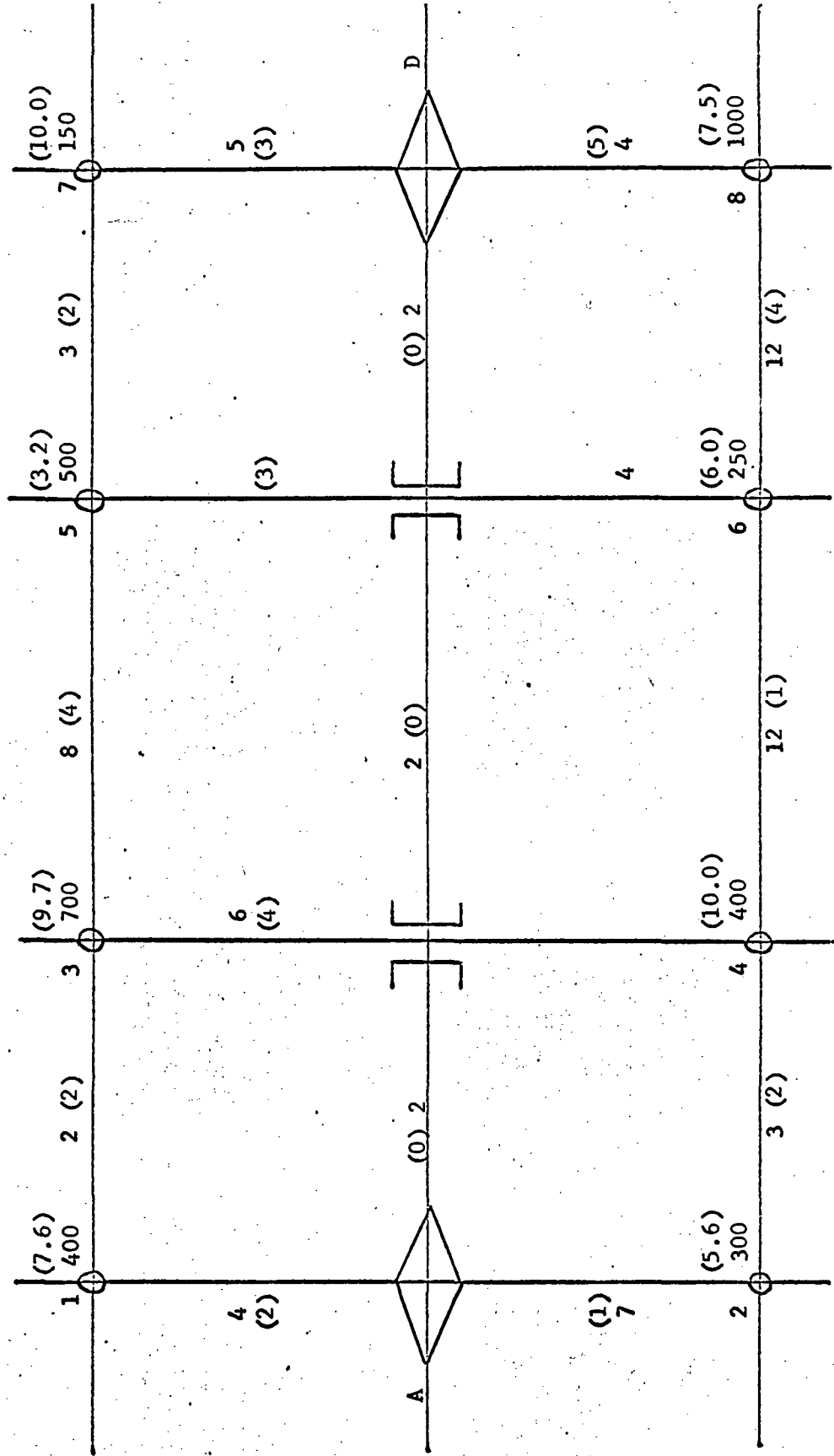

Legend: Mean Annual Income (7.6) (4) Accident Rating  
 Volume (ADT) - 400 8 - Travel Time

Table 8

ADT and Income Data

<u>Node</u>	<u>ADT</u>	<u>Mean Annual Income (Thousands of \$)</u>
1	400	7.6
2	300	5.6
3	700	9.7
4	400	10.0
5	500	3.2
6	250	6.0
7	150	10.0
8	1000	7.5

- 6.) The travel times between links are as shown in Figure 14. The roadways have highly varying geometrics (curves, grades, etc.), so that travel time is varied on the links, partially due to their configuration.
- 7.) Due to such geometrics, and pavement conditions, accident potential is variable on each link. Therefore each link is given an accident potential rating between 1 and 5, as seen in Figure 14.
- 8.) The settlement nodes 1-8 have different mean annual incomes of their inhabitants, as shown in Table 14. These result in different propensities to travel, as will be discussed below.
- 9.) The number and pattern of trips of the local travelers remains constant on the system after the installation of the facility. For purposes of the analysis, freeway benefits to local users will be considered very small, or negligible.

- 10.) Traffic growth on the freeway occurs with an elastic demand function, with growth increasing the same percent that perceived travel cost decreases.

Travel has a perceived cost implicit to it. A highly judgmental equation of perceived travel cost for each node was constructed for this study. It was postulated that perceived cost of travel varies directly with travel time, accident potential, and vehicle operating costs due to different geometrics, and indirectly with mean annual income. As such, a very crude equation of perceived travel cost was constructed as follows:

$$\text{Cost} = \frac{\begin{array}{c} \text{Effect of} \\ \text{Roadway Geometrics} \end{array} \quad \begin{array}{c} \text{Accident} \\ \text{Potential} \end{array} \quad \begin{array}{c} \text{Operating Costs} \\ \text{of Vehicle} \end{array}}{\text{Mean Annual Income in Thousands of \$}} \times 10^{-2}$$

*(Note: The equation above includes handwritten brackets above the terms: (Travel Time)<sup>2</sup>, Accident Rating, and .75 (Travel Time).)*

#### Solution Method

The method of solution is to calculate the minimum time path of travel from each node to every other node in the network, given that all crossroads are open. The same type of calculation is then made for the alternative configurations of both crossroads closed, and one open and one closed. The latter two configurations have less local accessibility, and therefore total minimum perceived costs of travel will be higher.

As stated in the assumptions, traffic demand on the rural freeway is assumed to have a unitary elasticity. The benefit of travel

on the high type of facility is the increase in consumer surplus due to lower operating costs, and increased travel. This amount is represented by area ABC in the diagram below.

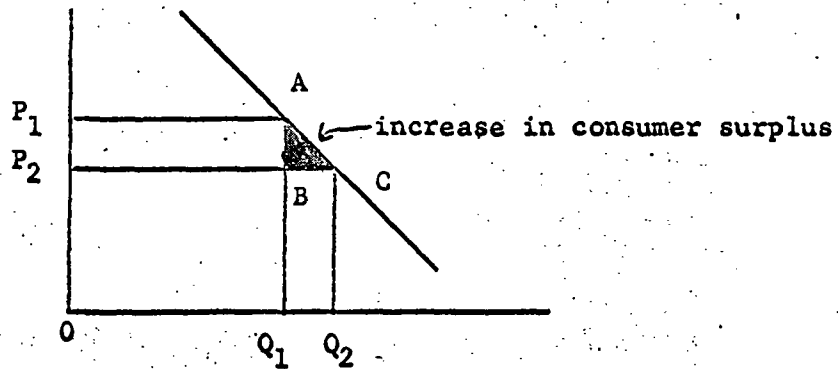

The capital and maintenance costs have been calculated for each of the improvement configurations, the first one having four structures, and the succeeding having two and three, respectively. In addition, the perceived cost has been calculated for all three configurations. This information is combined into two types of design criteria for discussion and comparison:

A.) The minimum cost criterion, which considers the discounted construction and maintenance costs plus perceived travel costs. These costs are discounted for a six percent interest rate and 20 year design life.

B.) A "Welfare Optimum" criterion, wherein the loss to those in the system who suffer an increase in perceived costs is compensated by those users of the freeway who receive increased benefits or consumer surplus due to the presence of a higher type facility for travel.

#### The Solution - Discussion

The solution to the problem is shown in the following tables. Table 9 shows the minimum perceived cost paths for all trips in the

system, with both facilities open. Tables 10, 11 and 12 show the minimum perceived cost matrices for the alternative configurations. Table 13 shows the discounted capital and maintenance costs for each freeway configuration, and Table 14 gives the discounted perceived costs for each facility type. Table 15 gives the increase in consumer surplus, or benefits to through travelers from freeway construction. Tables 16 and 17 show the calculations for analysis by the minimum cost method, and the welfare optimum method, respectively.

The installation of a freeway over the old, high cost alignment resulted in a traffic growth of 9,100 vehicles per day, and an increase in consumer surplus of \$733 for freeway users.

With both crossroads left open and bridged, the total capital plus perceived cost equals \$7,432,275, having the highest capital, but lowest perceived cost. With both crossroads closed, the total cost is \$7,248,395, while with one open and one closed the total cost is \$7,312,445.

In terms of minimum cost criteria, project No. 2 would be built, because of its being the minimum cost solution. By being the minimum cost solution, it costs society less, but costs the local tripmakers most. Is this truly an optimum design? In deference to the local tripmakers need of accessibility, the problem may be approached from a modified welfare point of view as follows:

Assume Design 1 will not be built because it has the highest total cost. Then which design alternative will be built, 2 or 3? By the Kaldor Criterion it may be argued that the design to be used is that which allows the gains to compensate the losses and still



Table 9

Perceived Cost Paths for All Trips\*

<u>Routing</u>	<u>Path</u>	<u>Cost</u>
Cell one to two	1-2	<u>.19</u>
Cell one to three	1-3	<u>.01</u>
Cell one to four	1-2-4	.28
	1-3-4	<u>.10</u>
Cell one to five	1-3-5	<u>.15</u>
Cell one to six	1-2-4-6	.92
	1-3-4-6	.55
	1-3-5-6	<u>.28</u>
Cell one to seven	1-FW-7	<u>.32</u>
Cell one to eight	1-2-4-6-8	1.94
	1-3-4-6-8	1.40
	1-3-5-6-8	.94
	1-3-5-7-8	.68
	1-FW-8	<u>.28</u>
Cell two to one	2-1	<u>.24</u>
Cell two to three	2-1-3	.33
	2-4-3	<u>.12</u>
Cell two to four	2-4	<u>.02</u>
Cell two to five	2-1-3-5	.79
	2-4-3-5	<u>.38</u>
	2-4-6-5	.68

\*The underlined figure represents the optimum, or minimum of all paths from a given origin to a given destination.

Table 9. (Continued)

<u>Routing</u>	<u>Path</u>	<u>Cost</u>
Cell two to six	2-6	<u>1.35</u>
Cell two to seven	2-1-3-5-7	1.09
	2-4-3-5-7	.76
	2-4-6-5-7	.90
	2-4-6-8-7	2.40
	2-FW-6	<u>.61</u>
Cell two to eight	2-8	1.35
	2-FW-8	<u>.55</u>
Cell three to one	3-1	<u>.01</u>
Cell three to two	3-1-2	.21
	3-4-2	<u>.10</u>
Cell three to four	3-4	<u>.07</u>
Cell three to five	3-5	<u>.08</u>
Cell three to six	3-4-6	.04
	3-5-6	<u>.03</u>
Cell three to seven	3-7	<u>.03</u>
Cell three to eight	3-4-6-8	.07
	3-5-6-8	.07
	3-5-7-8	<u>.06</u>
Cell four to one	4-3-1	<u>.12</u>
	4-2-1	.21
Cell four to two	4-2	<u>.01</u>
Cell four to three	4-3	<u>.05</u>

Table 9 (Continued)

<u>Routing</u>	<u>Path</u>	<u>Cost</u>
Cell four to five	4-6-5	.27
	4-3-5	<u>.22</u>
Cell four to six	4-6	<u>.15</u>
Cell four to seven	4-6-8-7	1.13
	4-6-5-7	.38
	4-3-5-7	<u>.31</u>
Cell four to eight	4-8	<u>.59</u>
Cell five to one	5-1	<u>.36</u>
Cell five to two	5-1-2	1.45
	5-3-4-2	<u>1.00</u>
	5-6-4-2	1.19
Cell five to three	5-3	<u>.02</u>
Cell five to four	5-3-4	<u>.67</u>
	5-6-4	.85
Cell five to six	5-6	<u>.07</u>
Cell five to seven	5-7	<u>.04</u>
Cell five to eight	5-7-8	<u>.51</u>
	5-6-8	.86
Cell six to one	6-5-3-1	<u>.36</u>
	6-4-3-1	.60
	6-4-2-1	1.17
Cell six to two	6-2	<u>.40</u>

Table 9 (Continued)

<u>Routing</u>	<u>Path</u>	<u>Cost</u>
Cell six to three	6-5-3	<u>.43</u>
	6-4-3	.57
Cell six to four	6-4	<u>.26</u>
Cell six to five	6-5	<u>.04</u>
Cell six to seven	6-5-7	<u>.10</u>
	6-8-7	.75
Cell six to eight	6-8	<u>.26</u>
Cell seven to one	7-1	<u>.19</u>
	7-FW-1	.32
Cell seven to two	7-5-3-1-2	.60
	7-3-4-2	<u>.43</u>
	7-5-6-4-2	.51
	7-8-6-4-2	1.54
	7-FW-2	.61
Cell seven to three	7-3	<u>.14</u>
Cell seven to four	7-3-4	<u>.21</u>
	7-5-6-4	.38
	7-8-6-4	1.00
Cell seven to five	7-5	<u>.02</u>
Cell seven to six	7-5-6	<u>.06</u>
	7-8-6	.47
Cell seven to eight	7-8	<u>.10</u>

Table 9 (Continued)

<u>Routing</u>	<u>Path</u>	<u>Cost</u>
Cell eight to one	8-7-5-3-1	.69
	8-6-4-2-1	1.92
	8-6-5-3-1	.95
	8-6-4-3-1	1.41
	8-FW-1	<u>.28</u>
Cell eight to two	8-2	1.01
	8-FW-2	<u>.55</u>
Cell eight to three	8-7-5-3	.57
	8-6-4-3	1.24
	8-6-5-3	<u>.54</u>
Cell eight to four	8-4	<u>.80</u>
Cell eight to five	8-7-5	<u>.22</u>
	8-6-5	.37
Cell eight to six	8-6	<u>.21</u>
Cell eight to seven	8-7	<u>.13</u>

Table 10

Minimum Perceived Cost Path Matrix - Both Crossroads Open

To

From	1	2	3	4	5	6	7	8	Total Aggregate Trip Cost
1	0	.19 1-2 75.60	.01 1-3 3.95	.10 1-3-4 40.00	.15 1-5 59.95	.28 1-3-5-6 113.50	.04 1-7 17.60	.28 1-FW-8 112.00	422.60
2	.24 2-1 72.00	0	.12 2-4-3 37.00	.02 2-4 6.95	.38 2-4-3-5 114.00	1.35 2-6 415.00	.61 2-FW-7 183.00	.55 2-FW-8 165.00	992.95
3	.01 3-1 5.80	.10 3-4-2 73.00	0	.07 3-4 53.00	.08 3-5 57.00	.03 3-5-6 21.70	.03 3-7 19.40	.06 3-5-7-8 38.50	268.40
4	.12 4-3-1 47.00	.01 4-2 5.20	.05 4-3 17.00	0	.22 4-3-5 112.00	.15 4-6 61.50	.31 4-3-5-7 124.00	.59 4-8 236.00	602.70
5	.36 5-1 178.00	1.00 5-3-4-2 500.00	.02 5-3 11.50	.67 5-3-4 335.00	0	.07 5-6 344.00	.04 5-7 20.04	.51 5-7-8 255.00	1645.54
6	.36 6-5-3-1 90.00	.40 6-2 100.00	.43 6-5-3 108.00	.26 6-4 65.00	.04 6-5 9.20	0	.10 6-5-7 25.00	.26 6-8 65.00	462.20
7	.19 7-1 28.10	.43 7-3-4-2 64.00	.14 7.3 20.30	.21 7-3-4 32.00	.02 7-5 3.30	.06 7-5-6 9.00	0	.01 7-8 14.40	171.10
8	.28 8-FW-1 280.00	.55 8-FW-2 550.00	.54 8-6-5-3 540.00	.80 8-4 800.00	.22 8-7-5 218.00	.21 8-6 210.00	.13 8-7 128.00	0	2726.00

Legend:

Individual Trip Cost  
Route  
Aggregate Trip Cost

7291.49

Table 11  
Minimum Perceived Cost Matrix - Both Crossroads Terminated

From	To	1	2	3	4	5	6	7	8	Total Aggregate Trip Cost
1	0		.19 1-2 75.60	.01 1-3 3.95	.28 1-2-4 112.50	.15 1-3-5 59.95	.93 1-2-4-6 367.00	.32 1-FW-7 17.60	.28 1-FW-8 112.00	787.60
2	.24 2-1 72.00		0	.33 2-1-3 98.00	.02 2-4 6.95	.79 2-1-3-5 238.00	1.35 2-6 415.00	.61 2-FW-7 183.00	.55 2-FW-8 165.00	1177.95
3	.08 3-1 5.80			0	.10 3-1-2-4 70.00	.08 3-1-2-4-6 57.20	.26 3-1-2-4-6 182.00	.03 3-7 19.40	.06 3-5-7-8 38.50	512.90
4	.21 4-2-1 84.00			.01 4-2-1-3 38.60	0	.17 4-2-1-3-5 67.20	.15 4-6 61.50	1.13 4-6-8-7 460.00	.59 4-8 236.00	1042.10
5	.36 5-1 178.00			.02 5-3 11.50	.53 5-3-1-2-4 265.00	0	.39 5-7-8-6 195.00	.04 5-7 20.04	.51 5-7-8 255.00	3406.54
6	1.17 6-4-2-1 290.00			.40 6-4-2-1-3 99.00	.26 6-4 65.00	.38 6-8-7-5 94.00	0	.75 6-8-7 187.00	.26 6-8 65.00	909.00
7	.19 7-1 28.10			.14 7-3 20.30	.01 7-8-6-4 150.00	.02 7-5 3.30	.47 7-8-6 9.00	0	.10 7-8 14.40	314.10
8	.28 8-FW-1 280.00			.57 8-7-5-3 571.00	.80 8-4 800.00	.22 8-7-5 218.00	.21 8-6 210.00	.13 8-7 128.00	0	2757.00

10907.19

Legend:  
Individual Trip Cost  
Route  
Aggregate Trip Cost

Table 12

Minimum Perceived Cost Matrix One Crossroad Terminated - One Open

From	To	1	2	3	4	5	6	7	8	Total Aggregate Trip Cost
1	0		.19 1-2 75.60	.01 1-3 3.95	.10 1-3-4 40.00	.15 1-5 59.95	.55 1-3-4-6 222.00	.32 1-FW-7 17.60	.28 1-FW-8 112.00	531.10
	.24 2-1 72.00		.12 2-4-3 37.00	.02 2-4 6.95	.38 2-4-3-5 114.00	1.35 2-6 415.00	.61 2-FW-7 183.00	.55 2-FW-8 165.00		992.95
	.01 3-1 5.80	.10 3-4-2 73.00		.07 3-4 53.00	.08 3-5 57.00	.04 3-4-6 28.70	.03 3-7 19.40	.06 3-5-7-8 38.50		275.40
4	.12 4-3-1 47.00	.01 4-2 5.20	.05 4-3 17.00	0	.22 4-3-5 112.00	.15 4-6 61.50	.31 4-3-5-7 124.00	.59 4-8 236.00		602.70
	.36 5-1 178.00	1.00 5-3-4-2 500.00	.02 5-3 11.50	.67 5-3-4 335.00	0	.72 5-7-8-6 360.00	.04 5-7 20.04	.51 5-7-8 255.00		1661.54
6	.60 6-4-3-1 150.00	.40 6-2 100.00	.57 6-4-3 130.00	.26 6-4 65.00	.38 6-8-7-5 95.00	0	.75 6-8-7 186.00	.26 6-8 65.00		791.00
	.14 7-3 28.10	.21 7-3-4 64.00	.02 7-5 20.30	.21 7-3-4 32.00	.02 7-5 3.30	.47 7-8-6 70.00	0	.10 7-8 14.40		232.10
8	.28 8-FW-1 280.00	.55 8-FW-2 550.00	.57 8-7-5-3 571.00	.80 8-4 800.00	.22 8-7-5 218.00	.21 8-6 210.00	.13 8-7 128.00	0		2757.00

Legend: Individual Trip Cost  
Route  
Aggregate Trip Cost

7845.59



Table 13

Capital and Maintenance Cost Estimates

Unit Capital and Maintenance Costs:

Seven miles of freeway at \$1,000,000/mile

Interchange A	\$9,000,000
Interchange D	\$7,250,000
Bridging at B	\$250,000
Bridging at C	\$340,000

Costs of each Alternative:

Alternative 1: Both Bridged	\$7,000,000
	9,000,000
FWF at 6% interest-20 year	7,250,000
design life: .3118	250,000
	340,000
	<u>\$23,840,000</u>

$23,840,000 \times .3118 = \underline{\underline{\$7,430,000}}$  discounted cost

Alternative 2: Both Terminated	\$ 7,000,000
	9,000,000
	<u>7,250,000</u>
	\$23,250,000

$23,250,000 \times .3118 = \underline{\underline{\$7,245,000}}$  discounted cost

Alternative 3: B-bridged -	\$ 7,000,000
C-terminated	9,000,000
	7,250,000
	<u>250,000</u>
	\$23,500,000

$23,500,000 \times .3118 = \underline{\underline{\$7,310,000}}$  discounted cost

Table 14

Discounted Perceived Costs of Each Alternative

1.) Both Open:	\$7291.49	
PWF	<u>.3118</u>	
Discounted Cost =	\$2275.00	= <u>\$2275.00</u>
2.) Both Closed:	\$10907.19	
PWF	<u>.3118</u>	
Discounted Cost =	\$ 3395.00	= <u>\$3395.00</u>
3.) One Open -		
One Closed:	\$7845.59	
PWF	<u>.3118</u>	
Discounted Cost =	\$2445.00	= <u>\$2445.00</u>

Table 15

Freeway Benefits

	<u>Original Road</u>	<u>Freeway</u>	<u>Difference</u>
ADT	10,000	19,100	9,100
Perceived Travel Cost	.568	.051	.517

Discounted Benefits = Discounted increase in consumer surplus, which equals

$$\begin{aligned} & \frac{\Delta P \times \Delta Q}{2} \times .3118 \\ & = \frac{.517 \times 9100}{2} \times .3118 \\ & = \$733 \end{aligned}$$

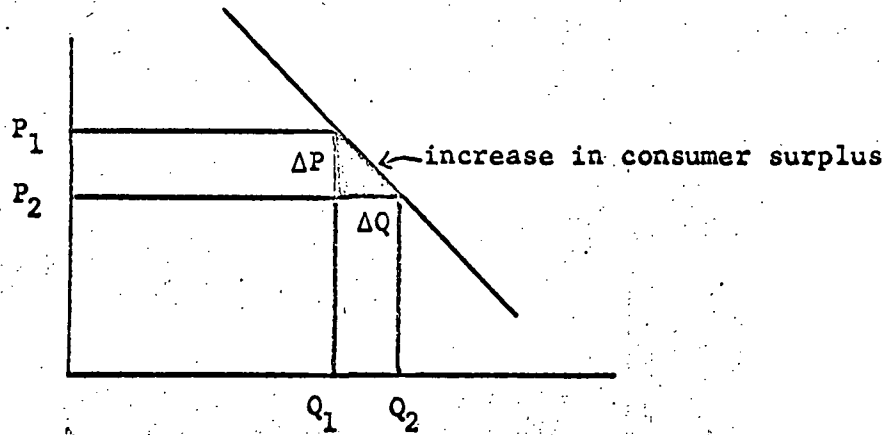

Table 16.

Minimum Cost Analysis Method

Design 1 (Both Open)	\$7,430,000	Capital and Maintenance Costs
	<u>2,275</u>	Perceived Cost
	\$7,432,275	Total
Design 2 (Both Closed)	\$7,245,000	Capital and Maintenance Costs
	<u>3,395</u>	Perceived Cost
	\$7,248,395*	Lowest Total Cost
Design 3 (One Open - One Closed)	\$7,310,000	Capital and Maintenance Costs
	<u>2,445</u>	Perceived Cost
	\$7,312,445	Total

Table 17

Welfare Criteria Analysis

Eliminate Design 1 from Consideration

For Design 2:

\$1,120	Differential perceived cost increase of 1 to 2
<u>-733</u>	Freeway benefits applied in compensation
\$ 387	Deficit remaining

For Design 3:

\$ 170	Differential perceived cost increase of 1 to 3
<u>-733</u>	Freeway benefits applied in compensation
\$ -563	Surplus left after compensation for losses

Design 3 is preferred under welfare criteria

maintain a surplus. Considering only the system of local travelers and freeway users, in the change from design alternative 1 to alternative 2, the loss to local travelers is an increased perceived cost of \$1,120. The gain to freeway users is \$733. This is not an improvement. However, in comparing design 1 to design 3, the increase in perceived costs, and loss to local travelers is \$170. Now the freeway user gains of \$733 balance this and leave \$563 left over. By Kaldor and Pareto criteria -- this is an improvement. Since it is unrealistic, and would cost to dismantle the new freeway and return the \$170 to the freeway users, thereby returning to the original design state, the Scitovsky criterion is also satisfied. Design alternative 3 is clearly the optimum, in terms of the welfare economics criteria.

It is pertinent at this time to consider all groups that significantly benefit or lose in the improvement program. They are:

The freeway user, who gains through lower operating costs, lowered travel time and decreased accident potential. This group's gains are the consumer surplus generated as travel demand increases, and cost of travel decreases, on the new facility.

The local traveler who is not affected. The traveler who makes trips from node 1 to node 3, node 3 to 5, node 5 to 7 or node 1 to 2, etc., whose travel time, safety and cost are not affected.

The local traveler whose accessibility is decreased. It is decreased due to the closing of the intermediate crossroads. Given his desire to make the same number of trips locally to the same destinations, his perceived cost of travel is increased, and he incurs a loss.

Society in General, or non-local-non-users of the specific facility, who have incurred a capital cost to pay for the freeway

that is built. They experience a loss, the money being used for the specific freeway improvement. However, they receive a gain in the form of indirect benefits such as lower prices, increased cultural mobility, generation of construction income, and other benefits, which balances their investment in the highway. In this form, the welfare optimum is also met, and design 3 is still optimum.

### Conclusions

Insights of welfare economics have not been employed in normal transportation systems benefit-cost analysis when applied to design. The use of such insights to the degree possible would be a step towards more sophisticated and all encompassing benefit-cost analysis. The improvement would depend on optimality criteria which operate for the welfare of all groups affected. The difficulty lies in identifying those groups, and measuring the gains or losses inputed to them.

There are several needed refinements of the assumptions made for this problem at this stage:

A.) In this case, traffic was assumed to stay constant for the local travelers after the location of the freeway. A more realistic assumption would have been an increase in travel of those nodes not adversely affected, and a decrease of those nodes adversely affected by the closing of local roads.

B.) Tantamount to the above, no community reorganization was assumed due to the presence of the freeway. Normally, after the installation of a high type facility, regional and local dominance of centers is shifted, and local travel patterns show a decided shift.

C.) Future research on the problem should construct a more realistic geographic distribution of income, and develop a more refined perceived cost formulation. Much research is needed by transportation economists and transport engineers into the value of time to people, and the perceived costs of travel. It should be noted that the concept of compensation of loss by those gaining has been used in the sense of all individuals having the same utility on money. This is not so, and a benefit-cost analysis using welfare criteria should ultimately address this question.

#### Further Research

Further research should be directed to experimentation with a model which includes the refinement of assumptions spoken of above. The long-run objective, however, should ultimately be enough relaxation of assumptions so that a general operational model of transportation benefit-cost analysis, using welfare economic criteria can be constructed. Should this not be possible, the application of welfare economic thinking to transport problems results in valuable insights which act as aids when considering aspects of systems and design problems, and their effect on users and non-users.



## CHAPTER VI - EMERGING CITIZEN PARTICIPATION PROGRAMS

### Introduction

Throughout this text, there has been an emphasis on development of algorithmic techniques which allow a better capture of value structure of subgroups who are impacted by transportation decisions, and the use of these techniques in a logical public works evaluation format.

A few major case studies attempting comprehensive use of citizen participation and a range of analytic techniques in evaluation are underway. They will be briefly described herein, and a concluding section on synthesizing formal modelling, citizen participation and the planning process will be developed.

### The Boston Transportation Planning Review

The Boston Transportation Planning Review (BTPR) was established by the Governor of Massachusetts as a task force of representative citizens early in 1970 due to public controversy over growing negative consequences resulting from increased highway construction. Highway construction was stopped pursuant to the creation of BTPR, and the governor instructed the task force to advise him on transportation controversies and directed that they be reviewed together as part of a balanced transportation program responding to the full range of metropolitan values.

Transportation controversies were identified in three subregional locations in Boston, the southwest, northwest, and north shore areas. The decision process involved interaction between the governor's office, and the above mentioned task force, composed of local elected officials,

**"Page missing from available version"**

No attempts were made to convert non-monetary evaluation impacts to dollar equivalents, or to weight criteria in terms of a common preference scheme or index. Rather, irreducible criteria were expressed in terms appropriate for their own individual evaluation, and weighed alongside those consequences which could be expressed in dollar terms, in the final decision-making approach.

West Prince George's County Transportation Alternatives Study-  
Maryland Department of Transportation

The Maryland Department of Transportation (MDOT) had determined from the beginning of a Transportation Alternatives Study that citizen participation was essential in the selection of possible alternatives as well as final design facilities. The citizen participation process took the form of a Steering Committee composed of community representatives, local elected officials, and local, regional, state and federal agencies.

The critical point to be noted is that the Steering Committee performed an active planning role as opposed to a more passive public hearing format. Local area transportation goals and objectives served as a basis for generating a broader set of goals and objectives deemed relevant for the particular geographic study area. This broader set dealt with problem areas in transportation, environment, social and neighborhood effects, economic costs, and land development and growth.

In a rather unique function, the Steering Committee also adopted a set of criteria to apply in the evaluation of proposed alternatives. These criteria were measurable quantities pertaining to the previously mentioned goals and objectives. An example is the environmental set of goals and objectives:

Goal I: Protect the environment from transportation-oriented damages and improve the quality of the environment where present standards of health and welfare are exceeded.

Goal II: Transportation program packages and their components should be planned to prevent environmental damage and must not contribute to the genesis of problems relating to health and safety of the populace. Impacts must meet with health and safety standards provided by federal, state and county governments.

These goals and objectives are evaluated by the following criteria:

- 1.) Air quality measures such as pollution concentrations by individual pollutant.
- 2.) Water quality measures such as resultant soil erosion and sedimentation.
- 3.) Noise levels generated by transportation vehicles and equipment, and their economic impact on adjacent land uses.
- 4.) Visual quality associated with transportation improvements.
- 5.) Effects on parks and open space.
- 6.) Impacts on fish and wildlife.
- 7.) Consideration of soils and geologic conditions.
- 8.) Effects on historic sites.
- 9.) Fuel consumption.

The Phase II Report was an assembly of data pertinent to the evaluation criteria relative to the possible alternatives developed in the Phase I Report. The use of this information is imperative to the construction of a viable framework to make specific modal decisions.

### Discussion and Comparison

A joint discussion of the BTPR and the Prince Georges, Maryland study is quite illuminating. It is apparent the BTPR is an attempt to restore order to the decision process after assessing growing negative citizen value feedback. The Prince Georges study, on the other hand, is a preventative study design, attempting to incorporate orderly citizen participation throughout the duration of the technical and public planning activity. In BTPR the interactive format of the task force is with the technical transportation planning personnel, with the primary responsibility of the task force being to act as a viable extension of the community value structure, and responsible to its components.

In the Prince Georges study, a more massive, representatively interactive approach appears to have been employed. Relevant neighborhood and community groups were identified, and through a series of "town hall meetings" a rather large steering committee was formed to generate alternatives, present them to the technical consultant and the community groups, and act as the synthesizing agent for the selection process. The consultant, it would appear, acted as a technical clearinghouse, to comment on technical, physical and scientific feasibility of alternatives generated, and supply, to the extent possible, quantitatively sound forecasts of resultant impacts.

As one reviews these studies in light of the planning process, the following points emerge:

- 1.) The value issue of the citizen is addressed in a plausible manner.

- 2.) The citizens have their questions answered.
- 3.) Through rejection and modification, new alternatives and compromises are possible.
- 4.) The process, from a philosophical and operational viewpoint, operates as a case study or scenario mechanism which addresses all of the "urban systems" theory and modelling questions shown in Figure 15.
- 6.) However, in addressing them, no structure or theory per se, is actually processed within the studies. The forthcoming BART Impact Study, however, attempts to structure the study activities, processes and results, at a theoretical and modelling evaluation level, doing so by proceeding along case study and before and after comparative formats.

#### Bart Impact Study

The BART Impact Study could validly be termed the next generation of case study activities away from BTPR and Maryland-Prince Georges efforts. In this forthcoming study attempt has been made to capture perishable pre-BART data on a variety of environmental, traffic, citizen preference and regional economic issues. Through a series of theoretical formats to be undertaken in the next  $2\frac{1}{2}$  years, ongoing with the completion and total operation with BART, an evaluation rationale will be developed consistent with the real world case study of actual BART operations. Specific impact studies to be employed with respect to the above include:

Travel behavior - using disaggregate travel modelling techniques, investigating travelers' response, and investigating travel needs.

Urban Systems Theory of Transportation Decisions

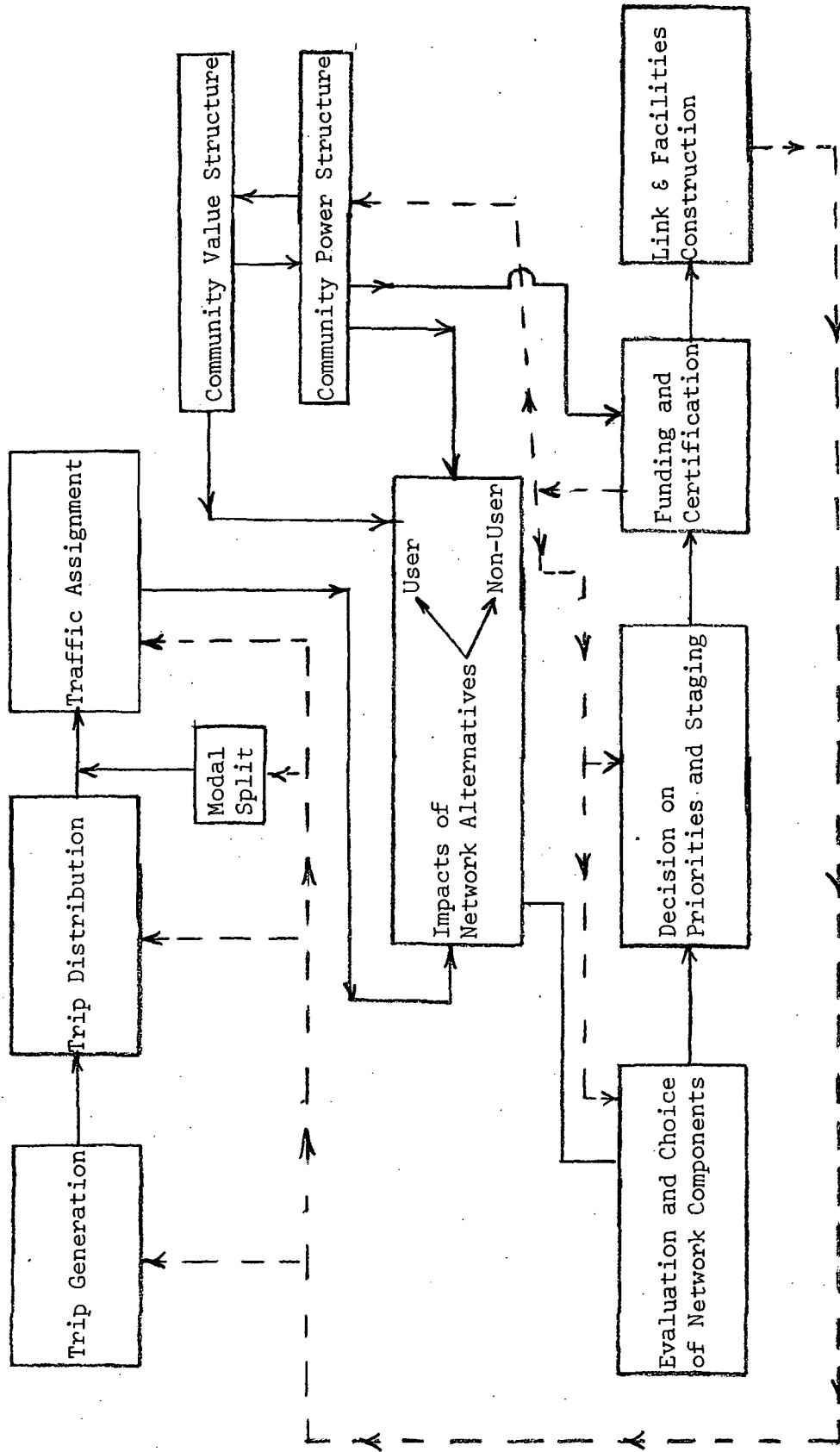

Figure 15

The environment with respect to:

land use and urban development.

impacts on regional tax base and financial health.

distribution of retail sales in selected areas.

impacts on residential environments and life styles, including perceptions of neighborhood quality, and relationship of such to BART.

The data to be collected, and the analysis and interpretation, are designed to answer one or more of the following:

The questions are of three kinds:

WHAT are the impacts of BART on travel conditions, economic activity, land use, public policies, and other aspects of life in the metropolitan region?

WHY do these impacts occur? Of equal interest, why do some anticipated impacts not occur, or occur in a lesser or different way than expected?

HOW can the fullest possible benefits be obtained from the Bay Area's investment in rapid transit, by complementary actions such as provision of feeder service, marketing transit service, and zoning for intensive development around the stations?

Equally important, how can the lessons of the BART experience be transferred to other metropolitan areas where investments in transportation improvement are being considered?

### Conclusions-Trajectory of Case Study Activities

Some limited conclusions can be drawn with respect to the trajectory of case study activities and development of the state of the



art with respect to citizen participation and formal evaluation modelling. Briefly:

- 1.) The citizen task force is being viewed as a viable and active aid to broadening and enlightening the decision process.
- 2.) Irregardless of 1, above, the framework of technical solutions and evaluation formats have definite technical bounds, and the procedures of participation and evaluation must deal with these technical bounds in a realistic, interactive manner.
- 3.) The BART studies represent the initiation of the use of theoretically rigorous evaluation approaches in public works. The theoretic approaches, developed in conjunction with a participation format typical of those discussed here, represent the most enlightened approach in the future to transportation systems evaluation programs.

The concluding chapter will attempt to synthesize the above points, in light of the technical and mathematical material presented in this report.

CHAPTER VII - CONCLUSIONS - SYNTHESIS OF RESEARCH AND  
ENGINEERING OPERATIONAL ISSUES

From the material presented in this report, it should be obvious that no general transportation evaluation model currently exists which can accurately and rationally deal with the subtleties of all of the impacts of any transportation technology on the entirety of groups affected by it. Further, the gap is great between currently available operational techniques and the theoretical questions which must be answered in a rigorous and comprehensive manner to render operability of evaluation at a more accurate and sophisticated level. Increased effort to this end must be achieved through activities which pursue the following research goals simultaneously: a.) vigorous theoretical modelling work on relevant decision and capital investment processes, as discussed in previous sections, b.) interpretation of such results into a nontechnical library of evaluation techniques for operating engineering and planning personnel, and c.) effective communication and interchange of ideas concerning the problem structure with these operating engineers and planning personnel, and the layman community at large affected by transportation system decisions.

In the context of the immediately above remarks, this state of the art report has focused on a broad array of topics, including the philosophy of public sector expenditures, individuals' preference structure in community planning, public participation, actual case studies, and several limited, but conceptually sound evaluation modelling algorithms. In a sense, it is a progress report, as research is continually working towards more refined assessment of

transportation alternatives, and more comprehensive, dynamic modelling approaches. One significant final concluding point is that in studying transportation systems, one should attempt to build theoretical analyses which closely parallel the real-world behavior related to the decisions for investment. In order to do so, in addition to adequate use of modelling theory, the analyst must be pragmatic about alternatives open to the real world under study, and must deeply consider the philosophy of planning or social structure which the technology is to support. Only in the integration of these items is evaluation and analysis meaningful.

APPENDIX - SELECTED ANNOTATIONS AND BIBLIOGRAPHIC LISTINGS

## Engineering-Economic Techniques-Minimum Average Annual Cost

### Engineering-Economic Systems Analysis for Transport Planning in Dahomey, West Africa

Tillo E. Kuhn, York University, Toronto, and  
Norman D. Lea, N. D. Lea and Associates Ltd., Toronto

This paper reports on methodological advances achieved by the Dahomey Land Transport Study, recently carried out by a Canadian group under the auspices of the United Nations Development Program and the World Bank. The study employed an engineering-economic systems analysis aimed at the accomplishment of desirable future transport tasks at minimum true costs to society.

There was full integration between transport planning per se, and socioeconomic developments, especially in the crucial agricultural sector, to the target year 1990. Given population estimates, production and consumption quantities, both present and future, for each node, the "TRANS" Model calculated individual commodity surpluses and deficiencies throughout the country. It then simulated freight and passenger movements through the land transport network by applying a "minimum cost path" criterion. These calculated traffic flows for the current year were then compared with actual movements, obtained through O-D studies and counts, and the TRANS Model calibrated.

The TRANS Model output, link inventory information, and new proposal costs were all fed into the "OPT" Model. Its chief purpose was to confront various traffic loads generated by the TRANS Model with different technical network designs. It selected from those the one combination that promised to handle the total logistics task at minimum total costs, also expressed in annual terms, the cost streams being discounted at relevant trial interest rates over the planning period 1969 to 1990. Inherent in the OPT Model were economic-technical interactions between vehicle and road, as analyzed by Robley Winfrey and Jan de Weille; tax content and foreign exchange adjustments; and convergent iterative traffic assignment versus network design calculations.

### Evaluation of New Urban Transportation Systems

Robert U. Ayres, Richard McKenna, and M. Lucius Walker, International Research and Technology Corporation

The large number of new urban transport systems can usefully be evaluated from an economic standpoint in terms of capital and operating costs per unit traffic flow. In this paper, we have considered a number of systems in a typical urban situation with a peak flow in either direction of 10,000 passengers per hour. It is convenient to distinguish three basic classes: continuous, network, and unconfined vehicle systems. These are embodied in eight abstract systems varying in their fundamental components or operational modes. Effective capacity of each class was found to deviate from design capacity by a factor that depends on characteristics such as headway, average velocity, and area per passenger. The physical requirements for each of the eight types of systems to meet the standard 10,000 per

hour demand have been specified in terms of this effective capacity. By using a number of cost equations, basic operating and capital costs have been developed for each type of system. Capital costs were amortized over typical lifetimes to provide total annual costs for each system.

#### Economic Analysis for Highways

Robley Winfrey. International Textbook Co. (Scranton, Penn. 18515), 1969.

The universal aspects of highways, the accumulation of highway needs, the limits on construction funds, and the widespread concern of almost every citizen give highway transportation a natural and compelling position in transportation. This position demands close and expert attention to the economy and to the general social and economic consequences of highways. This book is designed to serve these purposes through making available to the practicing engineers, economists, and analysts a source of theory, procedures, and applied data. It is the aim of this book to contribute toward a better understanding and application of economic analysis as a decision-making tool. Although this book stresses economic analysis on a project basis, the same principles, methods, concepts, and cost and benefit data apply equally well to analyses of highway systems. The main differences lie in the selection of input data.

#### Investment Appraisal Using Discounted Cash Flow Techniques

J. Bolton, Freeman Fox, Wilbur Smith & Associates.

Different flow levels over a one year period in design and base years are examined, and the cost of travel at the different flow levels for both a base situation and a test situation are estimated. This yields enough observations to enable a relationship between network flow and network benefit to be derived for a wide range of flows. Flows in an intervening year may be interpolated, and using the derived network flow and network benefit relationship, the corresponding benefits at this flow may be estimated. Repeating the process for each year of the project life enables the application of discounted cash flow techniques to give an estimate of the net present value of the scheme.

#### Economic Assessment of Road Projects

Lundin, C. and Wahlborg, S., National Road Board, Sweden, Planning Division.

An economic model for highway investment is being developed. The system chosen for the calculation is the capital value method. For every project of interest several alternatives are specified differing from each other only by the time of execution within the planning period. The economic consequences of the projects are solved by a computer program taking into account costs of construction, maintenance, accidents, motor vehicle operating, etc. The evaluation results in an investment plan showing the highest total capital value for a given rate of interest, and within the limits of the funds available each year.

Grant, Eugene L., Ireson, W. Grant, Principles of Engineering Economy, the Ronald Press Co., 1970.

Isard, Walter, etc. al., Methods of Regional Analysis: An Introduction to Regional Science, The MIT Press, Cambridge, Mass., 1960.

Martin, Brian V., A Model for the Evaluation of Transport Alternatives, Harvard Transportation and Economic Development Seminar, Discussion Paper No. 15, June 1965.

Kuhn, Tillo E. and Lea, Norman D., Engineering Economic Systems Analysis for Transport Planning in Dahomey, West Africa, Highway Research Board, No. 285, 1969.

Ayres, Robert U., McKenna, Richard, and Walker, Lucius M., Evaluation of New Urban Transportation Systems, Highway Research Board, No. 367, 1971.

The Derivation and Analysis of Transit Costs, The International Research and Technology Corporation, IRT-R-29/6, July 28, 1970.

Goodman, Joseph M., McDorman, Littleton, C. and Weiner, Edward, Evaluation of a Bus Transit System in a Selected Urban Area, Highway Research Record No. 314, 1970.

Winfrey Robley, Economic Analysis for Highways, International Textbook Co., Scranton, 1969.

Creasy, L. R., Economics and Engineering Organization Institute of Civil Engineers, Proc. Supplement (i), 1970.

Kahn, A. M., Evaluation of Transportation Demonstration Projects, Engineering Journal, Montreal, Vol. 54, February 1971.

Bolton, J., Investment Appraisal Using Discounted Cash Flow Techniques, Department of the Environment, United Kingdom (current research).

Wahlborg, S., Lundin, C., Economic Assessment of Road Projects, National Road Board, Sweden, January 1971.

### Benefit-Cost Ratio

Benefit-Cost Analysis and the Location of Urban Highways  
Eleanor B. Steinberg, Brookings Institution.

The location of urban highways has become a major source of unrest in American cities and a bone of contention between highway planners and urban populations. The argument developed in this paper is that some of the problems associated with route-location decisions are inherent in benefit-cost analysis as it is commonly practiced, but that a more fundamental weakness lies in the governmental framework in which benefit-cost analysis is conducted and the consequent burdens that are placed on it as a decision-making tool.

Before and After Benefit-Cost Analysis in Urban Transportation

E. Peterson and F. G. Mittelbach. Graduate School of Management, University of California, Los Angeles. Sept. 1972.

Expected benefits and costs associated with particular transportation projects were compared with actual results. Benefit-cost analysis is described in detail along with conceptual and practical problems. The Santa Ana Freeway in Los Angeles was a selected case study to compare ex ante-ex post benefits and costs with reference to time value savings for freeway users and highway commodity savings. The analysis revealed significant differences between the benefits and costs anticipated and those that were observed. The report concludes with recommendations to improve the effectiveness of benefit-cost studies in urban transportation decision-making.

Numerator-Denominator Issue in the Calculation of Benefit-Cost Ratios

Gerald A. Fleischer, Department of Industrial and Systems Engineering, University of Southern California.

The application of the benefit-cost ratio method to the evaluation of alternative highway designs and programs is of substantial interest. Several important reference works in this area point out that the magnitude of the ratio will be affected by the category to which a specific consequence is assigned, that is, whether an economic gain will be considered as a benefit (added to the numerator) or as a negative cost (subtracted from the denominator). The writers of these references proceed to justify the specific classification of certain consequences such as roadway maintenance costs and user costs. However, inasmuch as the only relevant issue is whether the ratio exceeds unity, the numerator-versus-denominator issue is without interest. A ratio cannot be altered from greater than unity to less than unity merely by adding (or subtracting) a constant from both numerator and denominator.

Generalized Costs and the Estimation of Movement Costs and Benefits in Transport Planning

P. T. McIntosh, Strategic Planning Directorate, Department of the Environment, London; and D. A. Quarmby, London Transport Office.

The object of the paper is to provide guidance to transport planners and analysts by describing procedures in two areas: (a) the evaluation of movement costs and benefits consequent to changes in networks and management policies and (b) the estimation of the generalized behavioral and resource cost functions for links and origin-destination pairs that are necessary for this evaluation process and for forecasts of behavior. The procedures are designed for use in situations where the change in network or policy is thought to have strong effects on the trip pattern and individual link loadings. This will generally be the case in the consideration of urban schemes and may be the case for major interurban schemes; in both situations there may be considerable changes in the trip matrices, modal split, and routes used. The emphasis is on operational methods. The precise way in which the benefit expression and generalized costs are calculated will depend on the level of detail and form of particular studies; considerable guidance is given to aid the transfer from concepts to computation.



Problems, Misconceptions, and Errors in Benefit-Cost Analyses of Transit Systems

Dan G. Haney, Stanford Research Institute

This paper is addressed to the process of evaluating transit systems alternatives in metropolitan areas. The conclusions are derived from the author's experience in conducting such studies and from a review of a number of recent reports. Some 15 separate issues are discussed, and conclusions are drawn as to appropriate research methods for each subject. First, the alternative of not conducting a benefit-cost analysis is discussed, and reasons are described why other methods, (e.g., professional judgment, cost of service, and financial feasibility) may lead to incorrect decisions. Conclusions are then drawn concerning the use of rating systems versus dollar-based evaluations, discounting, the choice of an interest rate, financing considerations, inflation, reflection of all public costs, the use of benefit-cost analysis only as justification for a single recommended system, the structuring of alternatives, analyzing benefits only to existing travelers, modal split and traveler benefit inconsistencies, measurement of motor vehicle running costs, factoring from daily savings to yearly savings, economic valuation of noneconomic factors, treatment of uncertainty, and interpretation of benefit-cost ratios.

Application of Cost-Benefit Analysis to Transport Investment Projects in Britain

D. W. F. Barrell and P. J. Hills. Transportation (Elsevier Pub. Co., Box 211, Amsterdam, Netherlands), Vol. 1, No. 1, pp. 29-54, May 1972.

This paper explains the need for the application of cost-benefit analysis to the evaluation of alternative projects for investment in the transport field and outlines briefly the historical development of the technique. The results of a comparative survey of a number of cost-benefit studies carried out in Britain and some conclusions as to their thoroughness and comprehensiveness (or otherwise) are presented. The article concludes with a number of specific and detailed recommendations, including use of discounted cash flow techniques, to remedy apparent methodological weaknesses.

Cost-Benefit Analysis: Bastard Science? And/or Insidious Poison in the Body Politick?

Alan Williams. Journal of Public Economics (North-Holland Pub. Co., Box 211, Amsterdam, Netherlands), Vol. 1, No. 2, pp. 199-225, August 1972.

Cost-benefit analysis is one of the techniques most prone to misunderstanding and misapplication in the hands of the uninitiated. CBA is shown to be a natural and logical extension of systems analysis, operations research, and cost-effectiveness analysis but more ambitious than them in evaluative scope and technique and hence rather more vulnerable at certain well-recognized points. Criticisms of CBA are reviewed from the economist's viewpoint, and the role and activities of the Roskill Commission on the Third London Airport are discussed.

A Break-Even Analysis of Alternative Express Transit Systems

D. Sawicki, Wisconsin University, Milwaukee, September 1972.

A number of alternative bus systems were studied using benefit-cost analysis; freeway flyer, a flyer over a dedicated lane, a priority access system complete with a freeway control system, and an independent busway. The major objective was to determine the break-even demand point where the benefit-cost ratio of one system becomes better than the others; for the evaluation a point to point express system was assumed for all three alternatives, as an actual route will be used from the freeway flyer's current route schedule. A computer program was generated which allowed demand to be input and yielded the various evaluative measures as output for all three systems. This allowed the use of sensitivity analysis in the final phases of the project.

Urban Public Transportation Capital Alternatives

Institute for Defense Analysis, November 1972.

The objective of this study is to determine the relative costs and benefits of urban public transportation (including taxicabs), and capital alternatives under various travel demand conditions, and then to evaluate these alternatives over a wider range of criteria and evaluate their feasibility. The study consists of four major tasks: update data base on urban public transit and taxicabs (using data from the American Transit Association and the International Taxicab Association); identify criteria to use in evaluating alternatives; identify alternatives consisting of bus, rail and taxicabs, evaluate the alternatives, and assess their feasibility; and, prepare a final report.

Duncombe, Bruce F. and Davie, Bruce F. Public Finance, Holt, Rinehart and Winston, Inc., 1972.

Russell, B. C., Assessment of the Cost/Benefit Ratio for Road Improvements in Developing Countries, Journal of Institution of Highway Engineers, Vol. 17, No. 6, London, England, June 1970.

Wilson, A.G., and Kirwan, R. M., Measures of Benefit in the Evaluation of Urban Transport Improvements, Centre for Environmental Studies, London, England, August 1969.

Barrell, D. W. and Hills P. J., Application of Cost Benefit Analysis to Transport Investment Projects in Britain, Transportation, Vol. 1, No. 1, Amsterdam, Netherlands, May 1972.

Vam der Tak, Herman G., and Anandarup, Ray, Economic Benefits of Road Transport Projects, International Bank for Reconstruction and Development, Johns Hopkins Press, 1971.

Wilgan, M. R., Benefit Assessment for Network Traffic Models and Application to Road Pricing, Road Research Laboratory, Rpt. LR417, 1971.

Williams, Alan, Cost-Benefit Analysis: Bastard Science? and/or Insidious Poison in the Body Politick?, Vol. 1, No. 2, North-Holland Publishing Co., Amsterdam, Netherlands, August 1972.

Peterson, E. and Mittelbach, F. G., Before and After Benefit Cost Analysis in Urban Transportation, Graduate School of Management, University of California, Los Angeles, September 1972.

Steinberg, Eleanor B., Benefit-Cost Analysis and the Location of Urban Highways, Highway Research Board, Highway Research Record No. 348, 1971.

Fleischer, Gerald A., Numerator-Denominator Issue on the Calculation of Benefit-Cost Ratios, Highway Research Board, Highway Research Record No. 383, 1972.

McIntosh, P. T. and Quarndy, D. A., Generalized Costs and the Estimation of Movement Costs and Benefits in Transport Planning, Highway Research Board, Highway Research Record No. 383, 1972.

Haney, Dan G., Problems, Misconceptions, and Errors in Benefit Cost Analyses of Transit Systems, Highway Research Record No. 314, 1970.

Sawicki, D., A Break Even Analysis of Alternative Express Transit Systems, UMTA, September 1972.

Institute for Defense Analysis, Urban Public Transportation Capital Alternatives, Dept. of Transportation, Office of Policy and International Affairs, November 1972.

Briston, M. R., and Rodriguez, F., Manchester-Buxton Railway Cost-Benefit Study, Center for Urban and Regional Research, U.K., July 1973.

#### Rate of Return

Davie, Bruce F. and Duncombe, Brude F., Public Finance, Holt Rinehart and Winston, 1972.

Highway Engineering Economic, Highway Research Board Special Report No. 108, January 1968.

Kraft, Gerald, Economic Aspects of Urban Passenger Transportation, Highway Research Board, Highway Research Record No. 285, 1969.

Kuhn, Tillo E. and Lea, Norman D., Engineering-Economic Systems Analysis for Transport Planning in Dahomey, West Africa, Highway Research Board, Highway Research Record No. 285, 1969.

Grant, Eugene L., and Ireson, W. Grant, Principles of Engineering Economy, Ronald Pub., 1970.

Alternative Multimodal Passenger Transportation Systems: Comparative Economic Analysis, National Cooperative Highway Research Program Report 146, 1973.

Net-Benefits

Economic Benefits of Road Transport Projects

Herman G. van der Tak and Anandarup Ray, World Bank Staff Occasional Papers No. 13, International Bank for Reconstruction and Development, 1971.

The economic evaluation of a project in any sector entails the measurement and comparison of cost and benefit streams expected from alternative investments. This paper presents an exposition of the social surplus method of measuring benefits. In this method, benefits are measured in terms of the concepts of consumers' and producers' surpluses. The exposition is intended to shed light on the nature of benefits to be expected from road transport projects, both with and without various types of market imperfections and, in particular, to show how these benefits relate to changes in the supply and demand of transported commodities. The method is designed for analyzing road projects in isolation from other investments. In some cases the benefits from a road transport project in any year can simply be measured by the product of the project-induced decrease in unit road-user costs and the normal volume of traffic. This measure will be valid only when the volume of traffic on the improved road is not responsive to changes in the unit transport cost. In general, however, traffic volume will increase with road improvement (as when a new road opens up an isolated region); measuring benefits only in terms of normal traffic will underestimate the benefits.

Measures of Benefit in the Evaluation of Urban Transport Improvements

A. G. Wilson and R. M. Kirwan, Centre for Environmental Studies, August 1969.

The paper discusses various alternative measures of user benefit applicable to the evaluation of urban transport schemes. It is assumed that benefit can be measured in terms of reductions in costs, where cost is a generalized function of financial outlay, time, comfort, and other factors. Four methods of estimating user benefit are discussed: the London Transportation Study formula, consumers' surplus, equivalent income variations, and cardinal utility functions. It is shown that under certain assumptions the first three measures yield the same result. The importance of the notion of constant marginal utility of money and the difference between cardinal and ordinal measures of utility are discussed.

Estimation of User Benefits from Alternative Urban Transportation Systems

T. N. Harvey, Drexel University, April 1971.

It is hypothesized that the estimation of user benefits from transportation systems, especially urban systems, can be improved considerably by using consumers' surplus measurements and certain concepts developed in welfare economics. A consumers' surplus measure of user benefit is put in perspective with regard to other measures of effectiveness

that have been proposed and/or applied. Values that are measured by consumers' surplus are rigorously defined in terms of economic theory. The evidence contained in trip generation, trip distribution, and modal split models is examined for clues to the sensitivity of demand to changes in the transportation system.

Evaluation of User Benefits Arising from Changes in Transportation Systems  
Martin J. Beckmann and James P. Wallace III, Transportation Science,  
November 1969.

This paper investigates the welfare implication of changes in the transportation system in two special areas. The first is when the origin-destination demand for transportation may be assumed to be fixed and the second case is when, considering only work trips, origins may vary but destinations may not. A technique is described that could be used to forecast the new origin-destination demand resulting from a change in the transportation system. The technique also provides an appropriate measure of the welfare implications. A particular objective of the paper is to point out the pitfalls of using transportation (generalized) cost saving as a welfare measure whenever origin-destination demand may not be assumed to be fixed. In this situation it is shown that the welfare measure must take into consideration the benefit derived from the increased choice in available housing sites.

Davie, Bruce F. and Duncombe, Bruce F., Public Finance, Holt, Rinehart and Winston, Inc., 1972.

Beckmann, Martin J. and Wallace, James P. III, Evaluation of User Benefits Arising from Changes in Transportation Systems, Transportation Science, Vol. 3, No. 4, November 1969.

Benefits of Interstate Highways, Federal Highway Administration,  
U.S. Department of Transportation, June 1970.

Harvey, T. N., Estimation of User Benefits from Alternative Urban Transportation Systems, Drexel University, April 1971.

Lansdowne, Z. F., Analysis of Intercity Transport Improvements: Forecasting Demand and Evaluating User Benefits, Rand Corporation, May 1970.

Neuburger, H., User Benefit in the Evaluation of Transport and Land Use Plans, Journal of Transport Economics and Policy, Vol. 5, No. 1, London, January 1971.

Goldberg, Michael A. and Heaver, Trevor D., A Cost-Benefit Evaluation of Transportation Corridors, Highway Research Board, Highway Research Record No. 305, 1970.

Complex Cost-Effectiveness Approaches-Linear Programming

Railroad Freight Train Scheduling: A Mathematical Programming Formulation  
E. K. Morlok and R. B. Peterson.

The problem of scheduling railroad freight trains is one that is of continual interest to the railroad industry. Presently, there is argument as to whether short, fast trains or long, slow trains are the most efficient and profitable way of hauling various traffic in differing geographic and competitive situations. The combinations of train size, speed, power, departure times, scheduled stops, traffic carried, and other variables make the determination of train schedules for even the most simple networks complicated. It seems appropriate, then, to attempt to develop efficient models for assisting decision-makers in the scheduling of freight trains through a railroad network.

The examination of a specific real-life problem led to the development of a general model, which was then tested on an actual, but simple rail network. The model was first formulated as a mathematical programming problem which turned out to be a solvable mixed-integer linear programming problem. The model is constructed so as to answer four important railroad operating questions: the route and intermediate stops of the trains run, their departure times, the cars per train, and the speed of the trains run. Total cost (train operating cost plus intermediate yard cost plus car-time and service cost) is minimized in the model, while a minimum level of service is provided.

The general model yields answers in terms of trains (defined by horsepower-to-tonnage ratio, car limit, route, and departure time), cars per train, and total car-hours used. The model is applied to a specific real-life problem, and results are obtained and compared with existing schedules. Finally, extensions of the model which will allow it to represent much larger networks and represent networks more realistically are described.

Hillier, Fredrick S. and Lieberman, Gerald J., Introduction to Operations Research, John Wiley & Sons, Inc., 1964.

Churchman, C, West, Ackoff, Russell L. and Arnoff Leonard E., Introduction to Operations Research, John Wiley & Sons, Inc., 1964.

Morlok, Edward K. and Peterson Richard B., Railroad Freight Train Scheduling: A Mathematical Programming Formulation, The Transportation Center, Northwestern University, May 1970.

Schaleger, Land Use Planning Design Models, Journal of the Highway Division, American Society of Civil Engineers, November, 1967.

Quandt, Richard E., Models of Transportation and Optimal Network Construction, Journal of Regional Science, Vol. 2, No. 1, 1960.

Garrison, William L. and Marble, Duane F., Analysis of Highway Networks: A Linear Programming Formulation, Highway Research Board Proceedings, Vol. 37, 1958.

### Non-Linear Programming

Non-Linear Programming and Duality Applications in Public Utility Firms  
Kapur, Kailash C., Wayne State University, College of Engineering.

For public utility firms, the objective is not the maximization of profits of the firm, but the maximization of social satisfaction and benefits. One of the ways in which the net benefits can be measured quantitatively is by the help of concepts of consumer's surplus and producer's surplus. A constrained optimization problem is formulated with the objective of maximization of net benefits subject to various constraints on the system parameters, such as capacity constraints regarding the size of facilities, regulatory profit constraints, typical network constraints, etc. A duality theorem is proved for such general non-linear optimization problems. The results are applied to the problem considered here. Many times, the computational aspects of the dual are easier as compared to primal and the dual may have nice economic interpretations.

Hillier, Frederick S., Lieberman, Gerald J., Introduction to Operations Research, Holden-Day, Inc., 1970.

Hadley, G., Non-Linear and Dynamic Programming, Addison-Wesley Pub. Co., 1964.

McCormick, Garth P. and Bracken, Jerome, Selected Applications of Non-Linear Programming, John Wiley & Sons, Inc., 1968.

McCormick, Garth P. and Fiacco, Anthony U., Non-Linear Programming: Sequential Unconstrained Minimization Techniques, John Wiley & Sons, Inc., 1968.

Kapur, Kailash, C., Non-Linear Programming and Duality Applications in Public Utility Firms, Wayne State University, College of Engineering.

### Goal Programming

Mathematical Methods of Optimization for Multi-Objective Transportation Systems

K. C. Kapur, Socio-Economic Planning Sciences, Pergamon Press, December 1970.

Transportation systems have multi-objective functions and there are multi-factor decision situations. A general mathematical optimization model for such systems is developed that has broad applications for the planning, system design and evaluation of many transportation systems. Three types of solution techniques are discussed. For multi-objective linear programs, a solution is obtained that satisfies the decision maker's preferences, and optimization from the decision maker's point of view is considered. A Goal Programming solution technique is given when goals for the system can be defined. If this is not possible, an overall utility function is defined on the various objective functions. A concept of additive utilities is also explored, and a parametric programming solution is given.

Kapur, K. C., Mathematical Methods of Optimization for Multi-Objective Transportation Systems, Socio-Economic Planning Sciences, Vol. 4, No. 4, Pergamon Press, December 1970.

Lee, Sang M., Goal Programming for Decision Analysis, Auerbach Publishers, 1972.

### Dynamic Programming

#### A Goal-Directed Transportation Planning Model

Morlok, Edward K., Northwestern University, The Transportation Center, January 1969.

A goal-directed or backward-seeking approach to planning has many characteristics in common with the general methodology of mathematical programming. In particular, it is very similar in conception to the general characteristics of dynamic programming. Dynamic programming treats problems as sequential decision problems, in which the search for an optimal solution proceeds from the end stage of the problem back toward the initial stage. If these stages correspond to period of time, then the program proceeds backward in time. The method suggested in this paper involves a merging of the general area of mathematical programming and in particular, dynamic programming and linear programming with graph theory as it is applied to the description and analysis of transportation networks.

For this application, each stage of the dynamic program corresponds to one time period, in which there exists a certain fixed network for the transportation system. The alternatives to be considered by the dynamic program at each stage correspond to different sets of this transportation fixed plant. For each such fixed network, there exists a large number of choices of service variables and other transport system variables which are continuous in nature, and this choice is made with the use of a linear program. A distinct linear program is run for each transportation fixed plant alternative.

Hillier, Frederick S. and Lieberman, Gerald J., Introduction to Operations Research, Holden-Day, Inc., 1970.

Kaufmann, A. and Cruon, R., Dynamic Programming: Sequential Scientific Management, Academic Press, 1967.

Churchman, C. West, Ackoff, Russell L., and Arnoff, Leonard E., Introduction to Operations Research, John Wiley & Sons, Inc., 1964.

Kaufmann, A., Graphs Dynamic Programming, and Finite Games, Academic Press, 1967.

Hadley, G., Non-Linear and Dynamic Programming, Addison-Wesley Pub. Co., Inc., 1964.



Bayesian Decision Theory

A Bayesian Decision Theory Approach to the Investigation of cost standard Deviations: An Empiric Study

Sinclair, Kenneth Paul.

This model is developed to evaluate quantity deviations from a standard of efficiency for a labor task. A standard for the labor task needed first to be established. Two alternatives (investigate, not investigate) were examined with respect to the task. Three states of nature are hypothesized to exist; performance of the work tasks may be:

- 1.) In control - standard measure plus control allowance.
- 2.) Unfavorably out of control - below in control state.
- 3.) Favorably out of control - above in control state.

With a payoff table for the above alternatives and the probabilities of various states, the expected costs of the alternatives are developed. The model was implemented on a large New England manufacturing company for one work task.

Western Prince Georges County Transportation Alternative Study

Maryland Department of Transportation.

The study group applied the Bayesian Decision Theory approach to dominant interest groups in the I-95 expansion proposal. This theory allowed the treatment of a wide range of choice selection, including deterministic and random decision elements.

Benjamin, Jack R., C. Allen Cornell, Probability, Statistics and Decision for Civil Engineers, McGraw Hill Book Co., New York, 1970, pp. 526-40.

DeGroot, Morris H., Optimal Statistical Decisions, McGraw Hill, New York, 1970.

Hoel, Paul G., Introduction to Mathematical Statistics, John Wiley & Sons, Inc., New York, 1947.

Schlaifer, Robert, Analysis of Decision Under Uncertainty, McGraw Hill Book Co., New York, 1969, pp. 140-200.

Sinclair, Kenneth Paul, A Bayesian Decision Theory Approach to the Investigation of Standard Cost Deviation: An Empiric Study, Doctoral Thesis, University of Massachusetts, August 1972.

Maryland Department of Transportation, Western Prince Georges County Transportation Alternatives Study, January 1973.

#### Markovian Decision Theory

Study of Traffic Flow on a Restricted Facility Interim Report: Phase I  
Carter, Everett E. and Sulur P. Palaneswamy.

There was a threefold objective pursued by this report: study the traffic flow on a restricted facility, develop a model to describe this traffic flow, and make recommendations for improvements. A finite state discrete time Markov model was used to explain the state space of the system. The state variables chosen were velocity, rate of flow, and density of vehicles operating on the roadway. The restricted facility chosen was the Baltimore Harbor Tunnel.

Carter, Everett C. and Sulur P. Palaneswamy, "Study of Traffic Flow on a Restricted Facility Interim Report: Phase I," Department of Civil Engineering, University of Maryland, College Park, Maryland, June 1973.

Howard, Ronald A., Dynamic Programming and Markov Process, MIT Press, Cambridge, 1960.

Howard, Ronald A., Dynamic Probabilistic Systems Volume I: Markov Models, John Wiley & Sons, Inc., New York, 1971.

#### Game Theory

Maintenance Station Location Through Operations Research at the Wyoming State Highway Department

Hayman, Robert W. and Clyde A. Howard.

This article dealt with the location of required maintenance stations by minimizing the sum of operational and depreciation costs.

This minimization was balanced by maximization of service benefits. The operational constraints of the critical maintenance facilities were also developed. The model was established for sanding as well as plowing operations.

A Capacity Analysis Technique for Highway Junctions

Wattleworth, Joseph A. and Jerry W. Ingram.

An objective function of a weighted set of variables (volumes entering the interchange) is maximized/minimized subject to the constraint equations. These constraint equations represent the capacities of each of the elements and the definition of movements through the intersection. The analysis can be used for a 24-hour count, although a diamond interchange during the peak hour was used.

Bennion, Edward G., Elementary Mathematics of Linear Programming and Game Theory, Michigan State University, 1960.

Davis, Morton D., Game Theory, Basic Books, Inc., New York, 1970.

Gale, David, The Theory of Matrix Games and Linear Economic Models, Brown University, Providence, Rhode Island, June 1957.

Hayman, Robert W., Clyde A. Howard, "Maintenance Station Location Through Operations Research at the Wyoming State Highway Department," Highway Research Record, Highway Research Board, No. 391, pp. 17-29.

Hughes, Ann J., Dennis E. Guwaig, Linear Programming and Emphasis on Decision Making, Addison Wesley Publishing Co., Reading, Mass., 1973.

Wattleworth, Joseph A., Jerry W. Ingram, "A Capacity Analysis Technique for Highway Interchanges, Highway Research Record, Highway Research Board, No. 398, pp. 31-36.

Simple and Hueristic Cost-Effectiveness Approaches

Ranking Techniques

Flint, A. G., "Community Values in Highway Planning," Australian Road Research Board, Paper No. 438, 1968.

This paper describes and analyzes techniques for incorporating community value considerations and recommends a rating system for comparing alternative highway proposals on the basis of community value criteria.

Barkan, B. G., "Latest Methods of Determining Urban Highway Routes," American Society of Civil Engineers, Journal of Urban Planning and Development Division, Vol. 93, No. UP4, December, 1967, pp. 5-18.

Though the overall principles of urban area route location are generally sound, inadequate weight frequently has been given to the less tangible and intangible factors involved. As an aid to policymakers, rating methods have recently been applied in several urban areas to evaluate the impact of alternate urban freeway routes on community, social and aesthetic values. There is a rapidly growing awareness of urban highway aesthetics, including consideration of both the view from the road and the view of the road. These emerging concepts will require new approaches including an interdisciplinary effort in the fields of urban highway planning and design. It is important to recognize that urban highways must help to enhance rather than destroy the urban setting.

Pikarsky, M., "Comprehensive Planning for the Chicago Crosstown Expressway," Highway Research Board, Research Record 180, 1967, pp. 35-51.

Primarily a case study type of report, with discussion directed towards levels of analysis (General, Intermediate, and Detailed) and a weighting procedure used in a rating method. The procedures described appear to be most applicable to major facilities in urban areas, where existing network capacity deficiencies are of primary concern.

American Society of Civil Engineers, "Criteria for Locating Major Streets and Urban Freeways," Report by the Committee on Urban Transportation, Journal of the Highway Division, American Society of Civil Engineers, June, 1968.

Bureau of Public Roads, "A Proposed Program for Roads and Parkways," U. S. Department of Commerce, June, 1966, p. 254.

Gardner, E. H., "The Congestion Approach to Rational Programming," Highway Research Board Bulletin 244, 1960, pp. 1-23.

"Latest Methods of Determining Urban Highway Routes," Journal of the Urban Planning and Development Division, American Society of Civil Engineers, December, 1967, pp. 5-18.

Pikarsky, M., "Comprehensive Planning for the Chicago Crosstown Expressway," Highway Research Board, Research Record 180, 1967, pp. 35-51.

Real Estate Research Corporation, "A Study of Airspace Utilization," 1968, p. 91.

Schimpler, C. C. and W. L. Grecco, "Systems Evaluation: An Approach Based on Community Structure and Values," Highway Research Board, Research Record 238, 1968, pp. 123-143, and Appendix B.

Rating Techniques

Hill, M., "A Method for the Evaluation of Transportation Plans," Highway Research Board, Research Record 180, 1967, pp. 21-34.

A much cited report on the applications and use of the Goals-Achievement Matrix. Numerous ideals, objectives and policies which are relevant in the analysis of transportation system impact are presented, and suggestions are made for their evaluation and weighting.

Article would be of interest to those trying to develop a broad understanding of available methods of analysis, specifically the Goals-Achievement method.

Manheim, M., "The Impacts of Highways on Environmental Values," Highway Research Board, Research Record 305, 1970, pp. 26-27.

A study was conducted to design a research program to evaluate the effects of different types of highways, and of various design features, on environmental values. The impacts of highways on environmental values are many and complex and evaluation must deal with seemingly immeasurable quantities such as construction costs, lost tax base or park land, effects of the highway on neighborhood stability, and displacements of families or jobs. Short-term impacts must be considered as well as long-term effects. An evaluation method to be practicable should be adaptable to different contexts, including variations in the significant issues involved in environmental values in different cities and variations in project scope and resources. An evaluation method must identify crucial trade-offs. The basic objective is to achieve an equitable, substantial agreement on a course of action. To achieve this, the proposed evaluation method has two components: evaluation technique and evaluation strategy. An impact matrix display was presented for each alternative action and for the impacts on each interest group. The evaluation technique consists of a set of operations that can be applied to the impact matrix. Evaluation strategy includes the development of alternatives, the identification of actors, and the prediction of the impact on them, the gathering of information about the values of the different actors, and the use of the evaluation technique to produce a ranking. A research program is described to develop the proposed evaluation method. The major activities to be conducted include case studies, the development of the evaluation technique, information display techniques, community interaction techniques, check lists and location team strategy as first priority areas, and the development of impact prediction models and situational data as second priority areas. A field test will be conducted to assist in evaluating and refining the techniques.

Smith, K. V., "Ranking and Selecting Methods for Capital Investment Decisions in Private and Public Sectors," Rand Corporation, Paper P. 4060, May, 1969.

This paper surveys and illustrates various analytical methods for assisting the capital investment decision process. Attention is limited to capital investments made by firms—referred to collectively as the private sector—and those made by governmental organizations within the public sector. Even though such a dichotomization is not complete—as witnessed by the governmental regulation, and sometimes control, or private entities—it does serve as a usable framework for the scope of private investment decisions includes new fixed assets. Replacement of existing fixed assets, make or buy decisions, buy or lease decisions, new product lines, and changes in distribution systems. Alternatively, governmental investment decisions could involve such public areas as health, education, transportation, recreation, and even space.

Dorman, A. A., "Environmental Values and the Freeway Planning Process," Public Works, September, 1963, pp. 99-101.

Engelen, R. E. and D. G. Stuart, "Transport Technologies and Urban Structure: A Framework for Evaluation," presented at the ASCE-ASME National Meeting on Transportation Engineering, Seattle, July, 1971, 51p.

Hill, M., A Method for Evaluating Alternative Plans: The Goals-Achievement Matrix Applied to Transportation Plans, Ph.D. Dissertation, Department of City Planning, University of Pennsylvania, Philadelphia, 1966.

McHarg, I. L., "A Comprehensive Highway Route Selection Method," Highway Research Board, Highway Research Record 246, 1968, pp. 1-15.

Potter, G. A. and I. C. Lloyd, Environmental Resource Analysis, for Oregon State Highway Division, 1970.

Wallace, McHarg, Roberts, and Todd, The Least Social Cost Corridor for Richmond Parkway, Department of Parks, City of New York, 1968.

Expected Value Techniques

Schimpler, C. C. and W. L. Grecco, "The Community-Systems Evaluation: An Approach Based on Community Structure and Values," Highway Research Board, Research Record 238, 1968, pp. 123-152.

This paper presents a procedure for the evaluation of alternative transportation system design concepts based on a comprehensive, weighted hierarchy of community development criteria. Existing techniques for alternative plan evaluation are discussed, along with several potentially powerful normative procedures for system design. The basic decision model relates to the evaluation of alternative design concepts by a single group of professional planners on the basis of a single set of weighted community decision criteria statements. Extensions of the basic model relating to a possible stratification of statements of value by socio-economic groups and a possible stratification of planners are indicated. Necessary discussion of community decision structure, formulation of community decision criteria, and weighting of those criteria are summarized. The decision model procedure is applied to three alternative systems design concepts for the transportation plan in the Louisville Metropolitan Area. Obvious extensions of the research are identified and applications of the procedures in land-use form and plan analysis, transportation corridor analysis, and detailed transportation system evaluation are discussed.

Gendell, D. S., "Evaluation of Alternative Transportation Systems," unpublished lecture notes from FHWA Urban Transportation Planning Course.

Hillegass, T. J., C. C. Schimpler and W. L. Grecco, "Community Decision Structure and Urban Planning Process," American Society of Civil Engineers, Journal of Urban Planning and Development, Vol. 96, No. 1, March, 1970, pp. 17-26.

Value Matrix Techniques

Strum, B. D., "Discussion of the Rank-Based Expected Value Method of Plan Evaluation and Systems Evaluation," Highway Research Board, Research Record 238, 1968, pp. 156-158.

The rank-based expected value method of plan evaluation described by Mr. Schlager is discussed. It was pointed out that the common practice of cost-benefit analyses cannot take all factors into account because of the difficulty of quantifying intangible criteria. A ranking of alternative plans with regard to the manner in which they need a rank set of regional planning objectives was proposed. A factor was added to the decision-making process called the probability of implementation which tends to temper optimistic or unrealistic plans with an appropriate air of certainty. Policy sessions help to identify the goals and standards and alternate transportation and land-use plans, to rank goals and objectives in order of preference, and to rank plans according to their ability to satisfy specific goals appear invaluable. This procedure should provide a dynamic and successful transportation planning process in the southeastern Wisconsin area. The paper presented by Messrs. Schimpler and Grecco is another approach directed toward the same problem. However, the techniques for ranking the regional goals and

objectives and determining the effectiveness of the various plan alternatives were developed through the application of decision-making theory and operations research. Through ranking and/or rating techniques, a utility value is determined relative to the importance of each goal to the region. Total plan effectiveness is measured for each plan through a decision model by summing all products of each plan effectiveness value times the utility value for each regional goal or objective. It is emphasized that the policy-maker must understand the plan evaluation procedure and take an active part in the development of an application of the plan evaluation procedure to determine the best transportation-land use plan for the region.

Hill, M., "A Method for Evaluating Alternative Plans: The Goals-Achievement Matrix Applied to Transportation Plans," Ph.D. Dissertation, University of Pennsylvania, 1966.

Loeks, C. D., "Community Values, Goals and Objectives for Metropolitan Areas and Local Jurisdictions," Twin Cities Metropolitan Planning Commission.

Oglesby, C. H., et. al., "A Method for Decisions Among Freeway Location Alternatives Based on User and Community Consequences," Highway Research Board, Highway Research Record 305, 1970, pp. 1-14.

Schlager, K., "The Rank-Based Expected Value Method of Plan Evaluation," Highway Research Board, Research Record 238, 1968, pp. 153-156.

Southeastern Wisconsin Regional Planning Commission, Forecasts and Alternative Plans 1990, Vol. II.



Desirability Rating Techniques

Craik, K. H., "Transportation and the Person," Journal of High Speed Ground Transportation, Vol. 3, No. 1, January, 1969, pp. 86-91.

This paper emphasizes the role of environmental psychology in transport system alternative decisions.

Falk, E. L., "Measurement of Community Values: The Spokane Experiment," Highway Research Board, Research Record 229, 1968, pp. 53-64.

This paper describes a desirability rating technique for comparing alternatives and considering socio-environmental factors, to arrive at transportation decisions.

Fielding, G. J., "Locating Urban Freeways, Methods for Resolving Community Conflict, Attitude Study II," University of California, Irvine, for California Division of Highways, 1971.

Improved methods are being developed and tested for encouraging and incorporating cross-section community participation in freeway route selection process. The project will apply value analysis theory and attitude change measurements in an actual route location situation.

Fishburn, P. C., "Intransitive Indifference in Preference Theory: A Survey," Operations Research, March-April, 1970, Vol. 18, No. 2, pp. 207-228.

This paper presents a survey of results in preference theory with intransitive indifference and discusses them for the areas of basic preference theory, consumer preference, additive utility, qualitative probability, expected utility, and social choice.

Mason, J. B. and C. T. Moore, "Development of Guides for Community Acceptance of Highway Location, Development, and Construction," Highway Research Board, Research Record 356, 1971, pp. 43-54.

This paper addresses a conceptual framework and the methodology for involving citizens and citizen groups in planning for and in establishing objectives of transportation.

Moore, C. T. and J. B. Mason, "Location Criteria for Highway and School Planners-Part A Findings, Conclusions, and Recommendations," "Part B, Theoretical and Methodological Framework," Alabama State Highway Department, HPR Reports No. 45-A(94P.) and 45-B(220P.), August, 1970.

The first report used quantitative association techniques to determine the internal and mutual consistency of highway location goals and criteria. Overcoming the lack of a substantive framework for considering conflicts is recommended. Part B consists of appendices, including a model for resolving planning conflicts.

Weiner, P. and E. J. Deak, "Nonuser Effects in Highway Planning," Highway Research Board, Research Record 356, 1971, pp. 55-68.

This paper discusses the use of questionnaires, completed by individual citizens and by citizen groups, to rank impacts of highways, both beneficial and detrimental. This can then be used in decision making.

Bishop, A. B., C. H. Oglesby, and C. E. Willeke, "Socio-Economic and Community Factors in Planning Urban Freeways," Stanford University for California Division of Highways, 1971.

The purpose of the study was to examine the urban freeway route location process in terms of (1) describing freeway planning route location as a process of social change, (2) showing the interactions of interest groups and their attitudes toward the planning process, (3) identifying the social and economic factors involved in route location and (4) developing a method for comparing and evaluating user and community consequences for decision making among alternatives. An analysis of the disadvantages of several planning strategies and approaches is presented, along with the results of a survey of attitudes of community officials and citizens toward the current California procedures for route location. The results of the analyses of possible approaches and the attitudinal survey show that (1) the coordinator-catalyst approach seems most appropriate and (2) considerable improvement in the decision-making process can be gained by involving local communities early through compensation of disbenefits, community participation, and getting the community to define its goals. A method is proposed that separates the direct economic effects and the community effects, the latter being analyzed through a graphical factor profile procedure. In addition, tentative numerical measures for quantification of community factors are suggested, along with an indication of the effect of the factor over time. The method of decision making is a series of paired comparisons, using engineering economic analysis and factor profiles.

McHarg, I. L., "A Comprehensive Highway Route Selection Method," Highway Research Board, Research Record 246, 1968, pp. 1-15.

The major deficiency in prevailing highway route selection methods has been the inability to include social values, including natural resources and aesthetic values, within the criteria utilized. In this study, an attempt has been made to identify components of social value, natural resources, and scenic quality, and to locate these geographically. It is presumed that the area of lowest social value, if transected by a highway, incurs the least social cost. The normal determinants of highway route selection, topography, soils, etc., have been expanded to include management or impairment of ground and surface water resources, susceptibility to erosion, etc. when highway corridors of minimum social cost and minimum physiographic obstruction were revealed, they were tested against their effect on scenic values. The objective of providing an excellent scenic experience was considered as a social value created by the highway. The corridor of least social cost was next tested against the degree to which it could create new and productive land uses where these would be necessary and welcome. The sum of least social cost and highest benefit alignment was identified. It is described as the rate of maximum social benefit.

Oglesby, C. H., et. al., "A Method for Decisions Among Freeway Location Alternatives Based on User and Community Consequences," Highway Research Board, Research Record 305, 1970, pp. 1-15.

A method is proposed that can be used in decision making among freeway location alternatives in urban areas and that incorporates both user and community consequences. It also proposes a step-by-step procedure that can both systematize and simplify the decision-making process. The proposed method presents a list of user and community factors as a basis for analysis. These are separated into (1) the direct economic effects, and (2) the community effects. In order to make the community effects more understandable, a graphical procedure called the factor profile is offered as a tool for analyzing them. In addition, tentative numerical measures for quantification of community factors and an indication of the effect of the factors over time are suggested. The method of decision making is a series of paired comparisons and uses engineering economic analysis and factor profiles.

Reidesel, G. A. and J. C. Cook, "Desirability Rating and Route Selection," Highway Research Board, Research Record 305, pp. 16-25.

Develops what could be called a model, but the main value of the article appears to be in its itemization of factors to be considered in an analysis procedure. Consideration is given to the weighting of impacts for various future time periods (0-5 yrs, 6-25 yrs, 26-50 yrs). Concludes with a desirability/cost ratio.

Vedder, Jr., "Planning Problems with Multidimensional Consequences," Journal, American Institute of Planners, March, 1970, Vol. 36, No. 2, pp. 112-119.

The multiple cost and benefit consequences stemming from program selection and implementation of a planning process are discussed. Planning decisions involve multi-dimensional consequences, which may include both explicit program goals and direct costs as well as spillover effects. Multi-dimensionality presents a problem in decision making because choice of a best program alternative implies ability to compare consequences in light of some decision criterion. An approach is presented consisting of a sequence of increasing levels of measurement. This approach can simplify the final decision problem by dropping out some alternatives at early stages in the analysis and making finer measurements on the remaining alternatives. The following general points are outlined: (1) successively higher levels of utility valuation may be made on multi-dimensional decision consequences, (2) successively higher measurement levels should produce an economy of total effort since some alternatives are eliminated at early stages of analysis and finer measurements are made on fewer alternatives, (3) the problem analysis is reduced largely to paired comparisons of consequences rather than direct comparisons among the many consequences and alternatives, (4) all levels of utility measurement described can handle consequences involving both benefits and costs, both qualitative and quantitative scales, and mixed natural units.

- Bartee, Edwin M., "Problem Solving with Ordinal Measurement," Management Science, June, 1971, Vol. 17, No. 10, pp. 622-633.
- Bellman, R. E. and L. A. Zadeh, "Decision-Making in a Fuzzy Environment," Management Science, December, 1970, Vol. 17, No. 4, pp. B-141-B-165.
- Bishop, B., "Socio-Economic and Community Factors in Planning Urban Freeways," Stanford University Report EEP33, October, 1969.
- Dickson, G. W., "A Generalized Model of Administrative Decisions: An Experimental Test," Management Science, September, 1970, Vol. 17, No. 1, pp. 35-41.
- Fishburn, P., Decision and Value Theory, Case Institute of Technology, 1964, Publications in Operations Research Series, No. 10.
- \_\_\_\_\_, "A Study of Lexicographic Expected Utility," Management Science, July, 1971, Vol. 17, No. 11, pp. 672-678.
- Hammond, J. S., "Better Decisions with Preference Theory," Harvard Business Review, Vol. 45, November, 1967, pp. 123-141.
- Howard, R. A., "Proximal Decision Analysis," Management Science, May, 1971, Vol. 17, No. 9, pp. 507-541.
- Keeney, R. L., "Utility Independence and Preferences for Multi-attributed Consequences," Operations Research, July-August, 1971, Vol. 19, No. 4, pp. 875-893.
- Kirby, R. F., "A Preferencing Model for Trip Distribution," Transportation Science, February, 1970, Vol. 4, No. 1, pp. 1-35.
- Oglesby, C. H. and G. E. Willeke, "A Search for Means of Identification and Quantification of Socio-Economic and Community Factors in Urban Freeway Locations," Stanford University for the California Division of Highways, 1969.
- Raiffa, H., Decision Analysis, Introductory Lectures Choice Under Uncertainty, California, Addison-Wesley Publishing Co., 1968.
- Spier, L., "A Suggested Behavioral Approach to Cost-Benefit Analysis," Management Science, June, 1971, Vol. 17, No. 10, pp. B-672-B-693.
- Turban, E. and M. L. Metersky, "Utility Theory Applied to Multivariable System Effectiveness Evaluation," Management Science, August, 1971, Vol. 17, No. 12, pp. B-817-B-829.
- Washington State University, A Study of the Social, Economic and Environmental Impact of Highway Transportation Facilities on Urban Communities, Pullman, Washington, 1968.

Approaches Employing Welfare Economics

A General Center City Transportation Evaluation Model

Haefner, Lonnie E. and Passonneau, Joseph R.

An evaluation model assessing the effect of various internal distribution systems on a downtown area is presented. The model uses decision theory to evaluate the interaction between transport systems and the center city neighborhoods they serve and between the center city systems and the urban region of which they are a part. Downtown Washington, D.C., is used as a case study to develop and to test the approach. One alternative which appears to be particularly efficient is examined in detail.

Baumol, W. J., Economic Theory and Operations Analysis, Englewood Cliffs, New Jersey, Prentice-Hall, 1965.

Environmental Studies Division, Environmental Protection Agency, Quality of Life Indicators, Washington, D.C. 1972.

Ferguson, C. E., Micro Economic Theory, Homewood, Illinois, Richard D. Irwin, Inc., 1966.

Irwin, N., "Public Transit and the Quality of Urban Living," High Speed Ground Transportation Journal, Vol. 3, No. 1, January 1969.

Passonneau, Joseph R., "Full Compensation in Urban Roadway Construction: A Necessary and Practical Objective," Highway Research Record 399, Highway Research Board, Washington, D.C. 1972.

Peat, Marwick, Livingston & Company, Redistribution of Socio-Economic Forecasts for 1980 and 1990, Prepared for Council of Governments, Washington, D.C.

Wingo, Lowden, Jr., Cities and Space: The Future Use of Urban Land, Baltimore: The Johns Hopkins Press, 1963.

Wohl, Martin and Martin, Brian V., "Evaluation of Mutually Exclusive Design Projects," Highway Research Board Special Report No. 92, Washington, D.C., National Academy of Sciences-National Academy of Engineering, 1967.

Emerging Citizen Participation Programs

A Description of the BART Impact Program, The Metropolitan Transportation Commission, July 1972.

Carter, E. C., Haefner, L. E. and Hall, J. W., An Informational Report on Techniques for Evaluating Factors Relevant to Decision Making on Highway Locations, Federal Highway Administration, Office of Environmental Policy, U.S. Department of Transportation, December, 1972.

Carter, E. C., Haefner, L. E. and Hall, J. W., Literature References on Techniques for the Evaluation of Factors Relevant to Decision Making on Highway Locations, Federal Highway Administration, Office of Environmental Policy, U.S. Department of Transportation, January 1972.

Haefner, L. E. and Redding, Martin J., "An Analytical Structure of Community Public Works Decision Processes," Papers and Proceedings of the 1972 Joint Conference of the Environmental Design Research Association and the American Institute of Architects, Irvine, California.

Haefner, L. E., "Transportation Planning-Myths and Methodologies," Realty and Investment, August 1974, St. Louis, Missouri.

Hansen, Walter G., "Planning and Design for Transportation System Management," Highway Research Board Special Report 142, Citizen Participation in Transportation Planning, pp. 121-123, Washington, D.C. 1973.

Lockwood, Stephen C., "Participation: Its Influence on Planning Methodology," loc. cit., pp. 116-120.

Northwest Draft Environmental Impact Statement, Preliminary Location Report, Program Package Evaluation Report, Boston Transportation Planning Review, January 1973.

Southwest Draft Environmental Impact Statement, Preliminary Location Report, Program Package Evaluation Report, Boston Transportation Planning Review, September 1972.

Webber, Melvin M., "On the Techniques and the Politics of Transport Planning," loc. cit., pp. 43-51.

Wofford, John G., "Public Participation in Balanced Transportation Planning," loc. cit., pp. 107-115.