

**NASA TECHNICAL
MEMORANDUM**

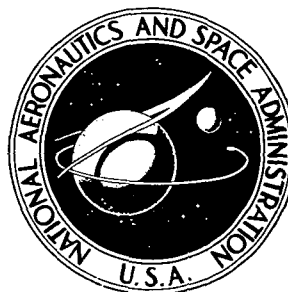

NASA TM X-3352

NASA TM X-3352

**POTENTIAL USE OF CERAMIC COATING
AS A THERMAL INSULATION
ON COOLED TURBINE HARDWARE**

Curt H. Liebert and Francis S. Stepka

Lewis Research Center

Cleveland, Ohio 44135



NATIONAL AERONAUTICS AND SPACE ADMINISTRATION • WASHINGTON, D. C. • FEBRUARY 1976

1. Report No. NASA TM X-3352	2. Government Accession No.	3. Recipient's Catalog No.	
4. Title and Subtitle POTENTIAL USE OF CERAMIC COATING AS A THERMAL INSULATION ON COOLED TURBINE HARDWARE		5. Report Date February 1976	6. Performing Organization Code
		8. Performing Organization Report No. E-8557	
7. Author(s) Curt H. Liebert and Francis S. Stepka		10. Work Unit No. 505-04	11. Contract or Grant No.
9. Performing Organization Name and Address Lewis Research Center National Aeronautics and Space Administration Cleveland, Ohio 44135		13. Type of Report and Period Covered Technical Memorandum	
		14. Sponsoring Agency Code	
12. Sponsoring Agency Name and Address National Aeronautics and Space Administration Washington, D.C. 20546		15. Supplementary Notes	
16. Abstract An analysis was made to determine the potential benefits of using a ceramic thermal insulation coating of calcia-stabilized zirconia on cooled engine parts. The analysis was applied to turbine vanes of a high-temperature and high-pressure core engine and a moderate-temperature and low-pressure research engine. Measurements made during engine operation showed that the coating substantially reduced vane metal wall temperatures. Evaluations of the durability of the coating on turbine vanes and blades in a furnace and engine were encouraging.			
17. Key Words (Suggested by Author(s)) Ceramics Insulation Stator blades		18. Distribution Statement Unclassified - unlimited STAR Category 07 (rev.)	
19. Security Classif. (of this report) Unclassified	20. Security Classif. (of this page) Unclassified	21. No. of Pages 23	22. Price* \$3.25

POTENTIAL USE OF CERAMIC COATING AS A THERMAL INSULATION ON COOLED TURBINE HARDWARE

by Curt H. Liebert and Francis S. Stepka

Lewis Research Center

SUMMARY

An analysis was made to determine the potential benefits of using a ceramic thermal insulation coating of calcia-stabilized zirconia on cooled engine parts. The analysis was applied to turbine vanes of a high-temperature and high-pressure advanced core engine and an existing moderate-temperature and low-pressure research engine. Measurements were also made of the insulating effect of the ceramic coating on a turbine vane in engine operation. And the durability of the coating on turbine vanes and blades was evaluated in a furnace and an engine.

The conditions assumed for the advanced core turbine analysis were an inlet gas pressure of 40 atmospheres, turbine-inlet gas temperatures of 1644 and 2200 K (2500° and 3500° F), and a cooling-air temperature of 811 K (1000° F). The conditions for the research engine turbine were an inlet gas pressure of 3 atmospheres, an inlet gas temperature of 1644 K (2500° F), and a cooling-air temperature of 319 K (114° F).

The results of the analysis illustrate that reductions in turbine-vane metal wall temperature of 390 K (700° F) are attainable at a coolant-to-gas flow ratio of 0.10 for the advanced core engine when the vanes are assumed to be coated with a 0.051-centimeter (0.020-in.) thickness of ceramic. Alternatively, large reductions in both coolant flow and metal temperature were also predicted. For example, core engine turbine vanes coated with 0.051 centimeter (0.020 in.) of ceramic could have both an eightfold reduction in coolant flow and a 110 K (200° F) reduction in vane metal temperature compared to an uncoated vane. Measurements made of the vane operating in the research engine showed that a 0.028-centimeter (0.011-in.) thickness of ceramic coating will reduce mid-span leading-edge metal temperature by 190 K (340° F) compared to the uncoated vane. Predictions of measured temperatures compared well with experiment.

Evaluations of the durability of the ceramic coating on turbine vanes and blades when tested in a furnace and during engine operation are encouraging. Further testing is required at the high gas pressure and temperature conditions of advanced core engines.

INTRODUCTION

Past work with cooled rocket engines operating at high gas temperatures and heat fluxes, such as described in reference 1, shows that ceramic coatings are good heat insulators and can withstand large temperature differences through the coating thickness. Ceramic coatings have also been tried (ref. 2) as a means for reducing the metal temperatures of uncooled turbine blades in a turbojet engine during transient operation. These uses of heat barrier coatings, however, were for short time periods of a minute or less. Furthermore, the engine tests reported in reference 2 were made at a relatively low turbine-inlet gas temperature and heat flux.

The operating conditions of current and future gas turbine engines - long-time steady operation at high pressure, temperature and stress levels - impose more severe strains on the coating. Also, the coating has to withstand several thousand hours of cyclic engine operation to gas temperatures as high as 2200 K (3500^o F) without cracking, spalling, or eroding. In addition, to be useful, the airfoil coating should have a low thermal conductivity and a low density and must not degrade turbine aerodynamic performance. The literature suggests that a stabilized zirconia coating may fulfill these requirements. The results of tests presented in reference 3 show that a stabilized zirconia coating has a very low thermal conductivity and density. In the tests described in reference 4, furnace heating elements of stabilized zirconia withstood 2000 hours and 2000 cycles before failure. These elements were cycled between 2273 K (3631^o F) and 300 K (80^o F). The hold time was 45 minutes at the higher temperature and 15 minutes at the lower temperature. Other tests described in reference 4 demonstrated that the zirconia withstood 1000 hours of steady-state operation at a temperature of 2373 K (3811^o F). In reference 5, aerodynamic losses were significant when a rough zirconia coating was applied. However, after the coating surface was smoothed, the aerodynamic losses were reduced by a factor of 2 and were found to be caused primarily by the additional thickness of the coating on the trailing edge. Based on these results, stabilized zirconia appeared to be a reasonable candidate for insulating hot metal engine parts such as combustor liners and turbine vanes, blades, and end-walls.

The study reported herein was conducted (1) to analyze the potential benefits of using a calcia-stabilized zirconia ceramic as an insulating coating for reducing turbine-vane airfoil metal temperatures and cooling flows and for increasing allowable turbine-inlet temperatures, (2) to evaluate the durability of the ceramic coating on turbine vanes and blades in furnace tests and engine operation, and (3) to measure the steady-state temperature reductions of a ceramic-coated vane metal wall in an engine and compare these results with analysis.

To determine the heat transfer benefits to be achieved by using calcia-stabilized zirconia as an insulator, a simple steady-state, one-dimensional heat transfer analysis was made on composite flat walls that consisted of a metal wall, a metallic bond coat, and

various thicknesses of zirconia coating. The analysis was made at gas and coolant conditions of both an advanced core engine turbine and a turbine in an existing research engine. The conditions assumed for the advanced core turbine were an inlet gas pressure of 40 atmospheres, turbine-inlet gas temperatures of 1644 and 2200 K (2500° and 3500° F), and a cooling-air temperature of 811 K (1000° F). The conditions for the research engine turbine were an inlet gas pressure of 3 atmospheres, an inlet gas temperature of 1644 K (2500° F), and a cooling-air temperature of 319 K (114° F). Turbine coolant-to-gas flow ratios were varied from 0.010 to 0.12. The zirconia coating thickness in the analysis ranged from zero to 0.051 centimeter (0.020 in.).

Coating durability and insulating effect were experimentally evaluated in the turbine of a research engine at the gas conditions previously described and at coolant-to-gas flow ratios from about 0.045 to 0.11. The adherence and durability of ceramic coatings were also evaluated in an electric furnace at temperatures of 1088 to 1394 K (1500° to 2050° F). The zirconia thickness on the vanes and blades was 0.028 centimeter (0.011 in.) in the engine tests and 0.005 centimeter (0.002 in.) to 0.051 centimeter (0.020 in.) in the furnace tests.

ANALYSIS

Method and Procedure

A simple one-dimensional steady-state heat balance through a composite wall, shown in the following sketch, was used to evaluate the potential benefits of using a ceramic coating as a thermal barrier for turbine airfoils. Thermal radiation heat transfer was neglected in this analysis. Also, to simplify the analysis, the influence of the added weight of the coating on the blade airfoil stress level was not considered.

If thermal conductivity is assumed to be a linear function of temperature, a heat balance across the composite wall results in

$$q = \frac{T_g - T_c}{\frac{1}{h_g} + \left(\frac{L}{k}\right)_I + \left(\frac{L}{k}\right)_{II} + \left(\frac{L}{k}\right)_{III} + \frac{1}{h_c}}, \text{ W/m}^2 \quad (1)$$

or

$$q = h_g(T_g - T_1) = \left(\frac{k}{L}\right)_I (T_1 - T_2) = \left(\frac{k}{L}\right)_{II} (T_2 - T_3) = \left(\frac{k}{L}\right)_{III} (T_3 - T_4) = h_c(T_4 - T_c), \text{ W/m}^2$$

The terms in equation (1) are defined in the appendix and are illustrated in the following sketch:

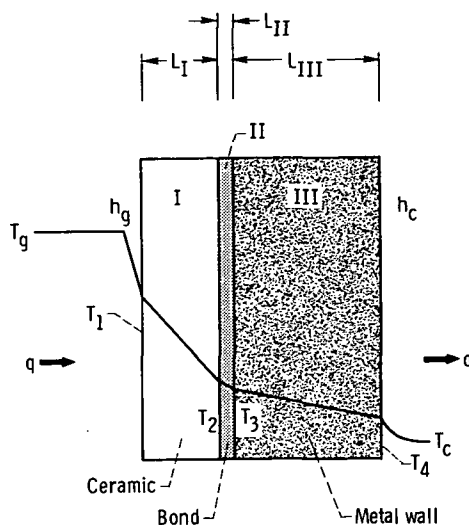

The parameters assumed to be known in this analysis were the coolant temperature T_c ; the thicknesses of the various layers L_I , L_{II} , and L_{III} ; and the heat transfer coefficients on the gas and coolant sides h_g and h_c , respectively. Appropriate values of the heat transfer coefficients were obtained from the literature. The gas-side coefficients were assumed to be constant for each engine condition of gas temperature and pressure selected, and the coolant-side coefficients were assumed to be power functions of the coolant flow. The thermal conductivities k_I , k_{II} , and k_{III} of each material layer were obtained from the literature and correlated as linear functions of material temperature by using linear regression analysis. The conductivities were evaluated at layer temperatures that were the arithmetic averages of the temperatures at the respective boundaries (1, 2, 3, and 4) of each of the three layers (I, II, and III).

The bulk temperature of the total turbine-vane metal wall $\bar{T}_{III,b}$ is a significant factor affecting vane life and was the primary variable used in evaluating the benefits of ceramic coatings applied over vanes. The metal wall temperature at the leading-edge region $\bar{T}_{III,le}$ was also used in comparing prediction with experimental data.

In predicting potential reductions in the metal wall temperatures $\bar{T}_{III,b}$ or $\bar{T}_{III,le}$ with increases in ceramic coating thickness L_I , we held T_g , h_g , T_c , and h_c constant for each of the two engines considered. These engines are discussed in the section Engine conditions. In predicting the potential of higher allowable gas temperature at given bulk metal wall temperatures $\bar{T}_{III,b}$ with increases in coating thickness, we held

h_g and T_c constant for each of the two engines considered. In predicting the potential reductions in coolant-to-gas flow ratio at given bulk metal wall temperatures $T_{III,b}$, we held T_g , h_g , and T_c constant for each of the two engines considered.

Conditions and Parameters

Engine conditions. - The gas and coolant conditions used were those of an advanced core engine turbine and those of a turbine of an existing research engine. The advanced core turbine had a high inlet gas pressure of 40 atmospheres, gas temperatures of either 2200 or 1644 K (3500^o or 2500^o F), and a cooling-air temperature of 811 K (1000^o F). It was chosen to evaluate the benefits of a ceramic thermal insulating coating on cooled turbines or parts that are subjected to conditions of high heat flux. The research engine had a lower gas pressure level of 3 atmospheres, a gas temperature of 1644 K (2500^o F), and a cooling-air temperature of 319 K (114^o F). It was used to evaluate the benefits of the coating at lower heat flux conditions. The predicted reductions in metal wall temperatures in the research engine were also compared with temperatures measured in the engine. A summary of these conditions and the equations for gas- and coolant-side heat transfer coefficients are given in table I. Cross sections of the turbine vanes of the advanced core and research engines are shown in figures 1(a) and (b), respectively.

Wall and coating parameters. - The thicknesses of the metal walls L_{III} and the bond coating L_{II} used in the analysis are given in table I. The thickness of the ceramic coating L_I was varied from zero to 0.051 centimeter (0.020 in.). The turbine-vane wall material was assumed to be MAR-M-509 (ref. 6) for the core engine and was MAR-M-302 (ref. 7) for the research engine. The bond coating material was nichrome (80Ni-20Cr), and the ceramic coating material was 5 weight percent of calcia-stabilized zirconia.

Heat transfer coefficients. - Use was made of published and unpublished data to obtain the required heat transfer coefficients for each of the assumed engine conditions.

Core engine turbine: The gas-side heat transfer coefficient was an integrated average of calculated local values determined at the hub, midspan, and tip locations around the periphery of the vane. The effects of temperature on property values were neglected in this analysis, and the coefficient was assumed to be a constant 8994 W/(m²)(K). The coolant-side coefficient was an integrated average of local coefficients determined around the interior periphery of the impingement-cooled vane:

$$h_c = 5.6 \times 10^4 \left(\frac{w_c}{w_g} \right)^{0.62}, \text{ W/(m}^2\text{)(K)} \quad (2)$$

Research engine turbine: The heat transfer coefficients for the midspan leading-edge region and the average over the entire vane were obtained by using data from references 8 and 9 for gas-side conditions and from references 10 and 11 for coolant-side conditions. The gas-side heat transfer coefficient at the leading edge of the vane was

$$h_{g,le} = 1.48 (Re)_f^{0.5} (Pr)_f^{0.4} \frac{k_f}{D_{le}}, \text{ W}/(\text{m}^2)(\text{K}) \quad (3)$$

which, for the conditions of the research engine, gives a value of 2326 W/(m²)(K). The coolant-side heat transfer coefficient at the leading edge was

$$h_{c,le} = 7.6 \times 10^3 \left(\frac{w_c}{w_g} \right)^{0.49}, \text{ W}/(\text{m}^2)(\text{K}) \quad (4)$$

The gas-side heat transfer coefficient for the entire vane was 1186 W/(m²)(K), and the corresponding coolant-side heat transfer coefficient was obtained from the relation

$$h_c = 9.6 \times 10^3 \left(\frac{w_c}{w_g} \right)^{0.7}, \text{ W}/(\text{m}^2)(\text{K}) \quad (5)$$

Thermal conductivity. - For the purposes of this analysis, thermal conductivities of the various layer materials were obtained from published experimental data as linear functions of average layer temperatures. The equations for the temperature variation of thermal conductivity for the two metal wall materials considered (MAR-M-302 for the research engine and MAR-M-509 for the advanced core engine), the bond material (nichrome), and the ceramic coating material (calcia-stabilized zirconia) are presented in table II. The data for MAR-M-302 were obtained from reference 7, for MAR-M-509 from reference 6, and for nichrome and the stabilized zirconia from reference 3.

APPARATUS AND PROCEDURE

The procedure used for depositing the ceramic coating onto the metal substrate was to prepare the substrate surface, plasma spray on a bond coating, and then plasma spray on the ceramic coating.

Various combinations of surface preparations, bond coatings, and ceramic coatings were first evaluated for durability in furnace cyclic tests. One bond coating and one

ceramic coating thickness of each combination were applied to flat sheets of a nickel-base alloy material. Furnace cyclic testing was then performed on those coated vanes and blades that had the best coating combination, as determined from the flat sheet tests. A single surface preparation, one bond coat thickness, and three different ceramic coating thicknesses were evaluated on these vanes and blades. The durability and the insulating capabilities of the coating were also evaluated on blades and vanes operating in a research turbojet engine. For these engine tests, one bond coat thickness and one ceramic coating thickness were used.

Coated Specimens

Flat sheets. - Twenty-seven coated flat specimens were prepared with combinations of three different metal surface roughening preparations, three different bond coat materials, and three different ceramic coating materials. The metal specimens were grit blasted (surface roughened) with either aluminum oxide or glass bead grit or were used in the as-received condition. The bond coating materials investigated were nichrome (80Ni-20Cr), molybdenum, or nickel-aluminum (95.5Ni-4.5Al). The ceramic coating materials were 5 weight percent of calcia-stabilized zirconia, aluminum oxide, or hafnium dioxide. The bond and ceramic coating thicknesses were maintained at 0.0102 centimeter (0.004 in.) and 0.0508 centimeter (0.020 in.), respectively. The metal specimens were fabricated from 0.198-centimeter (0.078-in.) thick Inconel alloy 718 HT sheet stock (ref. 6) to surface dimensions of 7.6 centimeters by 15.2 centimeters (3 in. by 6 in.).

Vanes and blades. - All airfoil surfaces were grit blasted with aluminum oxide, after which a bond coating of nichrome was applied to a thickness of 0.0102 centimeter (0.004 in.). For the furnace tests, calcia-stabilized zirconia was applied at thicknesses of 0.0051, 0.0254, or 0.051 centimeter (0.002, 0.010, and 0.020 in.). For the engine tests, the ceramic thickness was 0.028 centimeter (0.011 in.).

Coating Equipment and Procedure

Powders of bond and ceramic materials were applied separately with a plasma flame spray gun (ref. 12). In the gun an electric arc is contained within a water-cooled nozzle. Argon gas passes through the arc and is excited to temperatures of about 17 000 K (30 000⁰ F). The powders were mechanically fed into the nozzle and were almost instantaneously melted at this temperature. The plasma of ionized gas containing the melted powders impinged nearly perpendicularly upon the surfaces of the metal

specimens. During the plasma spray process, the metal substrate temperature did not exceed 420 K (300^o F).

After the surfaces were cleaned or roughened, the bond coating and the ceramic coating were applied within 15 minutes to minimize surface oxidation. Several other factors were controlled during the coating process. The inlet supply pressure to the grit blasting equipment was maintained at about 7×10^5 N/m² (100 psia), and the blasting gun was held nearly perpendicular to the surface. The plasma spray gun was also held nearly perpendicular to the surface at distances of 15.2 and 10.2 centimeters (6 and 4 in.) for bond and ceramic applications, respectively.

Test Equipment

Furnace. - A commercial electric furnace was used to evaluate coating adherence in air. Coated specimens were placed in the furnace for 10 minutes and then withdrawn and air cooled to 300 K (80^o F). The furnace temperature was 1367 K (2000^o F) for tests with the sheet specimens and 1088 to 1394 K (1500^o to 2050^o F) for tests with the vanes and blades.

Engine. - An existing research turbojet engine modified to investigate air-cooled turbine vane and blade configurations was used to evaluate the durability and insulative effects of the coatings. Figures 1(b) and (c) present cross sections of the vane and blade used. Further details of the vane and blade are given in references 10 and 13, respectively. Instrumentation provided measurements of turbine-inlet gas temperature and pressure, cooling-air inlet temperature and flow rate, and test-vane metal wall temperature.

Two coated vanes and three uncoated vanes were used in the investigation. The coolant flow to each of these five vanes was measured in a bench test at room temperature over a range of inlet pressures. The flow rates between vanes were found to be uniform to within 2 percent.

One of the coated vanes and one of the uncoated vanes was instrumented with a Chromel-Alumel thermocouple at the midspan of the leading edge. The thermocouples were imbedded in radial grooves in the wall to measure the average temperature of the metal with and without a ceramic insulating coating. The details of the thermocouple installation are described in reference 14. The two coated vanes along with the three uncoated vanes were fitted into a segment of the vane ring where the coolant flow to the vane group could be independently controlled and measured.

Two coated blades were fitted into the turbine wheel for evaluation of coating durability under rotating conditions. A thermocouple was installed in the metal wall of one of the coated blades at the midspan leading-edge position.

Durability of the coating in the engine was evaluated as part of another research

test. The operating conditions and the number of starts and shutdowns were, as a consequence, partially influenced by the other test. The coated vanes and blades were usually operated at turbine-inlet gas temperatures of 1367 to 1644 K (2000^o to 2500^o F) and a gas pressure of 3 atmospheres. The resulting coated vane and blade leading-edge metal temperatures generally did not exceed 920 K (1200^o F). On several occasions, hot starts resulted in transient metal temperatures of 1200 K (1700^o F).

The thermal insulation of the coating was evaluated at steady-state operation of the engine at a turbine-inlet gas temperature and pressure of 1644 K (2500^o F) and 3 atmospheres, respectively. The coolant-to-gas flow ratios during these tests were about 0.045, 0.06, 0.09, and 0.11.

RESULTS AND DISCUSSION

The results of our analytical and experimental investigation demonstrate the benefits and satisfactory short-time (150 hr) durability of a ceramic coating on cooled engine parts.

Analysis of Coating Benefits

Predicted reductions in bulk turbine-vane metal temperature and coolant-to-gas flow ratio with increases in ceramic coating thickness on vanes in the advanced core engine turbine and in the research turbine are shown in figures 2(a) and (b), respectively. Vane metal temperature $\bar{T}_{III,b}$ was substantially reduced as ceramic coating thickness was increased. And reductions in metal temperature with increasing coating thickness were greater for the core engine than for the research engine. The reason is the higher heat fluxes associated with the condition of the core engine.

The metal wall temperature of the advanced core turbine vane could be reduced by as much as 390 K (700^o F) at a coolant-to-gas flow ratio of 0.10 when the vanes were coated with a 0.051-centimeter (0.020-in.) thickness of zirconia (fig. 2(a)). When both coolant flow and metal wall temperature were allowed to vary, large reductions in both metal temperature and coolant flow were predicted. Vanes coated with a 0.051-centimeter (0.020-in.) thickness of zirconia could have both an eightfold decrease in coolant flow and a 110 K (200^o F) reduction in metal temperature compared to the uncoated vane. The coolant flow ratio was reduced from 0.10 to 0.0125, with a corresponding vane metal temperature reduction from 1390 K (2040^o F) to 1280 K (1844^o F).

The dashed portions of the curves in figure 2(a) illustrate a limitation associated with using the current ceramic composite coatings in applications such as the core engine

with high gas temperature and pressure. The limitation is the ability of the ceramic coating to adhere to the bond coating when the temperature at the interface between these two layers exceeds 1367 K (2000^o F). The basis for this ceramic/bond interface temperature limit, indicated by the tick marks in the figure, is discussed in the section Coating Durability.

Thin layers of the ceramic coatings (<0.006 cm (0.002 in.)) at the highest coolant-to-gas flow ratio of 0.10 (fig. 2(a)) were not sufficient to drop the temperature at the ceramic/bond interface below the limiting temperature of 1367 K (2000^o F). As the heat flux through the vane was reduced by lower coolant-to-gas flow ratios, thicker layers of the coating were required to give acceptable interface temperatures.

Reducing the heat flux also reduced the thermal gradients through the metal wall. Together with a constant limiting interface temperature, this resulted in slightly increased average vane wall metal temperatures (fig. 2(a)).

Although not shown in figure 2, calculations indicate large temperature drops through the coating. The largest drop of 932 K (1678^o F) occurred through a 0.051-centimeter (0.020-in.) thick ceramic coating on the turbine vane of the core engine at a coolant-to-gas flow ratio of 0.10. At these conditions, the coating outer temperature was 1980 K (3104^o F) and the ceramic/bond interface temperature was 1048 K (1426^o F). The temperature drop through the same coating thickness on the turbine vane of the research engine was calculated to be 351 K (632^o F) at a coolant flow ratio of 0.06. The coating outer temperature for this condition was 1147 K (1604^o F), and the ceramic/bond interface temperature was 796 K (972^o F). The resulting average ceramic coating temperature was considerably higher in the core engine (1514 K (2265^o F)) than in the research engine (972 K (1290^o F)). In general, the differences in gas temperature levels and heat fluxes for the two engine conditions resulted in the temperature gradients through the coating on the advanced core engine vanes being about 2.7 times those of the research engine. The larger temperature gradient, coating exterior surface temperature, and ceramic/bond interface temperature would impose more severe strains on the coating in the advanced core engine.

Figure 3 shows the calculated effect of coating thickness on allowable turbine-inlet gas temperature for vanes operating at constant metal temperatures and coolant-to-gas flow ratios. Figure 3(a) shows the results for the gas pressure level of 40 atmospheres expected in an advanced core engine, and figure 3(b) the results for a gas pressure of 3 atmospheres in the research engine. The base level of the turbine-inlet gas temperature for both engines was assumed to be 1644 K (2500^o F) when there was no thermal barrier on the vanes. It was at this base level that the metal temperatures of the uncoated vanes were determined for each coolant-to-gas flow ratio for each of the engines. The figure shows that, at the same vane metal temperature or coolant-to-gas flow ratio, the increase in allowable gas temperature was greater with increasing coating thickness

for the core engine than for the research engine. The higher heat flux through the turbine vanes of the core engine made the insulating properties of the coating more effective than it was in the lower-heat-flux research engine. For example, at a metal temperature of 1262 K (1812⁰ F) a zirconia thickness of 0.0195 centimeter (0.0077 in.) permitted a potential increase of 556 K (1000⁰ F) in the inlet gas temperature of the core engine as compared to an allowable gas temperature increase of 85 K (153⁰ F) for the research engine. Curves for coolant flow ratios of 0.03 and lower are not shown in figure 3(a) because of unacceptably high ceramic/bond interface temperatures.

Coating Durability

The adherence of the coating composition was evaluated by cyclic testing of coated flat sheet specimens and actual turbine-vane and blade hardware in an electric furnace. Testing at steady-state and cyclic conditions was also performed in the research turbojet engine.

Furnace tests. - The results of the tests on the 27 coated flat sheet specimens indicated that the best procedure and coating consisted of (1) abrasive blasting of the specimens with aluminum oxide grit, (2) plasma spraying of a bond coat of nichrome, and (3) plasma spraying of a coating of calcia-stabilized zirconia. The specimen with this coating satisfactorily completed 10 cycles between room temperature and 1367 K (2000⁰ F) before the tests were arbitrarily terminated so that tests on the durability of coatings on actual vanes and blades could be started. The sheet specimens with the other surface preparations and coating composites generally failed in two cycles.

The furnace cyclic test results on three different thicknesses of calcia-stabilized zirconia on one vane and one blade showed that the coating will adhere well to a nichrome bond coat without signs of deterioration for 40 cycles between 300 K (80⁰ F) and 1367 K (2000⁰ F). However, the zirconia ceramic separated from the bond coat after only 5 cycles to temperatures of 1394 K (2050⁰ F). The deterioration was especially apparent on the convex surfaces and leading edges of the blade and vane. These results indicate that the ceramic/bond interface limiting temperature was about 1367 K (2000⁰ F).

Engine tests. - The evaluation in engine operation of 0.028-centimeter (0.011-in.) thick calcia-stabilized zirconia on each of two vanes and blades, which was conducted as part of other research, showed no evidence of coating deterioration after as many as 35 start and stop cycles, four hot starts, and 150 hours at gas temperatures as high as 1644 K (2500⁰ F). The measured leading-edge vane and blade steady-state metal wall temperatures were as high as 920 K (1200⁰ F), and the transient values were as high as 1200 K (1700⁰ F). Figure 4 shows one of the blades after completion of the tests. No deterioration is evident. Although these results are encouraging, more testing is required. Based on the data given in the preceding section, the average coating temper-

ature and temperature drop through the coating are significantly greater for the core engine than for the research engine. As a consequence, the results of the tests reported herein do not provide a basis on which to estimate the durability of the coating when it is subjected to the more severe conditions of the core engine. Testing is required at higher gas pressures and temperatures.

Comparison of Measured and Predicted Coating Performance

Figure 5 compares calculated and measured wall metal temperatures at the midspan of the leading edge of an uncoated and a coated turbine vane operating in the research engine. The comparison is shown over a range of calculated coolant-to-gas flow ratios from 0.04 to 0.12 and includes measurements at ratios of about 0.045, 0.06, 0.09, and 0.11. The results show good agreement between prediction and measurement. The predicted and measured reductions in leading-edge metal temperature for the coated vane agreed within 25 K (45° F). The results show large reductions in leading-edge metal temperature with the 0.028-centimeter (0.011-in.) thick coating. At the coolant-to-gas flow ratio of 0.06 the metal temperature was reduced by 190 K (340° F) - from 1055 K (1439° F) for the uncoated vane to 865 K (1097° F) for the coated vane.

CONCLUDING REMARKS

Thermal radiation heat flux was neglected to simplify the analysis. The effects are negligible for the low pressure conditions of the research engine. However, as gas pressures and temperatures increase, the absorbed radiation heat flux increases, particularly when the part directly views the combustion gases. The higher reflectance of the zirconia coating, 0.8 compared to 0.2 for the bare metal, provides the additional potential benefit of reducing the radiative heat flux absorbed by hot parts. This benefit to the turbine vanes and blades was estimated to be small except at the leading edge of the first-stage vanes, which directly view the combustion flame. The higher reflectivity of the coating would be particularly beneficial for reducing the metal temperature of combustor liner walls. This benefit would be in addition to the insulating effect of the coating. The ability of the coating to maintain a high reflectivity with prolonged engine operation is not known and needs to be investigated.

It is important to emphasize that the benefits of a thermal barrier coating are directly related to the level of heat flux through the uncoated hardware. As a consequence, hardware or portions of it that are poorly cooled will not show large benefits with a coating. Trailing-edge regions of turbine vanes and blades of small engines, for example,

have a physical limitation on the use of effective cooling geometries and thus would not show large benefits from a thermal barrier coating.

Application of thermal barrier coatings to existing hardware could limit the potential benefits for the reasons just mentioned and also could impose aerodynamic losses because of increased trailing-edge thickness. Coating benefits can best be maximized when the coating is integrated into an original design. The added weight of the coating increases the stress level in rotating parts, which may diminish some of the potential benefits of the coating.

Although the results obtained are encouraging, more testing is required at the high gas pressure and high temperature conditions of advanced core engines, where the coating may be especially susceptible to particle erosion, corrosion, vaporization, thermal fatigue, and thermal shock.

SUMMARY OF RESULTS

The following are the results of calculations made to demonstrate the benefits of zirconia ceramic coatings on turbine parts and of initial tests to evaluate the coating durability.

1. Reductions in vane metal temperature of as much as 390 K (700^o F) at a constant coolant-to-gas flow ratio of 0.10 were predicted for an advanced core turbine when the vanes were assumed to be coated with a 0.051-centimeter (0.020-in.) thickness of zirconia.

2. Alternatively, large reductions in both coolant flow and metal wall temperature were predicted for coated vanes operating in the advanced core turbine. Vanes coated with a 0.051-centimeter (0.020-in.) thickness of zirconia could have both an eightfold decrease in coolant flow and a 110 K (200^o F) reduction in metal temperature compared to the uncoated vane.

3. The potential benefits from the ceramic coating were greater for a turbine of a high-gas-pressure core engine than for a low-gas-pressure research engine. At a metal temperature of 1262 K (1812^o F), a zirconia thickness of 0.0195 centimeter (0.0077 in.) provided a potential increase in the allowable turbine-inlet gas temperature of 556 K (1000^o F) for the vanes of the core engine as compared to an increase of 85 K (153^o F) for the research engine.

4. Zirconia coatings with thicknesses of 0.0051 and 0.051 centimeter (0.002 and 0.020 in.) adhered well to vane and blade metal walls without signs of deterioration when cycled 40 times by alternately heating in a furnace to 1367 K (2000^o F) and air cooling to 300 K (80^o F).

5. The zirconia coating on cooled turbine vanes and blades, which was tested as part of other research, withstood 35 start and stop cycles and 150 hours of testing in a research engine at gas temperatures as high as 1644 K (2500^o F) without deteriorating. The coating consisted of a 0.028-centimeter (0.011-in.) thickness of calcia-stabilized zirconia covering a 0.015-centimeter (0.006-in.) thickness of nichrome bond coat on MAR-M-302 metal walls.

6. The zirconia coating reduced the measured midspan leading-edge vane metal temperature in the research engine by 190 K (340^o F) - from 1055 K (1439^o F) for the uncoated vane to 865 K (1097^o F) for the coated vane.

7. Predicted temperature reductions for turbine vane walls insulated with zirconia coating compared well with experimental data taken in the research engine. The agreement was within 25 K (45^o F).

Lewis Research Center,
National Aeronautics and Space Administration,
Cleveland, Ohio, Nov. 19, 1975,
505-04.

APPENDIX - SYMBOLS

D	diameter
h	heat transfer coefficient
k	thermal conductivity of gas
k_I, k_{II}, k_{III}	thermal conductivity of ceramic coating, bond coating, and metal wall, respectively
L_I, L_{II}, L_{III}	thicknesses of ceramic coating, bond coating, and metal wall, respectively
Pr	Prandtl number
q	heat flux
Re	Reynolds number
T	temperature
$\bar{T}_I, \bar{T}_{II}, \bar{T}_{III}$	average layer temperature of ceramic coating, bond coating, and metal wall, respectively
w	mass flow rate
Subscripts:	
b	bulk, integrated average over entire vane
c	coolant side
f	film
g	gas side
le	leading edge
1	gas-zirconia interface
2	zirconia-nichrome interface
3	nichrome - metal wall interface
4	metal wall - coolant interface

REFERENCES

1. Price, Harold G. ; Schacht, Ralph L. ; and Quentmeyer, Richard J. :
Reliability and Effective Thermal Conductivity of Three Metallic-Ceramic
Composite Insulating Coatings on Cooled Hydrogen-Oxygen Rockets.
NASA TN D-7392, 1973.
2. Schafer, Louis J. , Jr. ; Stepka, Francis S. ; and Brown, W. Byron: Comparison of
Theoretically and Experimentally Determined Effects of Oxide Coatings Supplied
by Fuel Additives on Uncooled Turbine-Blade Temperature During Transient
Turbojet-Engine Operation. NACA RM E53A19, 1953.
3. Wilkes, K. E. ; and Lagedrost, J. F. : Thermophysical Properties of Plasma
Sprayed Coatings. (Battelle Columbus Labs. ; NAS3-13329), NASA CR-121144,
1973.
4. Halback, C. R. ; Page, R. J. ; and Arthur, P. D. : 2200^o C Oxidizing Atmosphere
Furnace for Space Manufacturing. AIAA Paper 74-154, Jan. -Feb. 1974.
5. Stabe, Roy G. ; and Liebert, Curt H. : Aerodynamic Performance of a Ceramic-
Coated Core Turbine Vane Tested with Cold Air in a Two-Dimensional Cascade.
NASA TM X-3191, 1975.
6. MAR-M Alloy 509: Physical Properties. Martin Marietta, 1969.
7. High Temperature, High Strength Nickel Base Alloys. The International Nickel Co. ,
Inc. , 1964.
8. Gladden, Herbert J. ; Gauntner, Daniel J. ; and Livingood, John N. B. : Analysis
of Heat-Transfer Tests of an Impingement-Convection and Film-Cooled Vane in
a Cascade. NASA TM X-2376, 1971.
9. Gladden, Herbert J. ; and Yeh, Frederick C. : Comparison of Heat-Transfer Test
Data for a Chordwise-Finned, Impingement-Cooled Turbine Vane Tested in a
Four-Vane Cascade and a Research Engine. NASA TM X-2595, 1972.
10. Yeh, Frederick C. ; Gladden, Herbert J. ; and Gauntner, James W. :
Comparison of Heat Transfer Characteristics of Three Cooling Configurations for
Air-Cooled Turbine Vanes Tested in a Turbojet Engine. NASA TM X-2580, 1972.
11. Yeh, Frederick C. ; et al. : Comparison of Cooling Effectiveness of Turbine Vanes
with and without Film Cooling. NASA TM X-3022, 1974.
12. Metals Handbook. Volume 2 - Heat Treating, Cleaning, and Finishing. Eighth ed. ,
Am. Soc. for Metals, 1964.

13. Fallon, Gerald E. ; and Livingood, John N. B. : Comparison of Heat-Transfer Characteristics of Two Air-Cooled Turbine Blades in a Turbojet Engine. NASA TM X-2564, 1972.
14. Crawl, Robert J. ; and Gladden, Herbert J. : Methods and Procedures for Evaluating, Forming, and Installing Small-Diameter Sheathed Thermocouple Wires and Sheathed Thermocouples. NASA TM X-2377, 1971.

TABLE I. - ANALYTICAL CONDITIONS

Parameter	Turbine vane type	
	Advanced core engine	Research engine
Turbine-inlet gas temperature, K	1644 and 2200	1644
Turbine-inlet gas pressure, atm	40	3
Gas-side heat transfer coefficient, W/(m ²)(K):		
Leading edge	----	2326
Bulk	8994	1186
Coolant-side heat transfer coefficient, W/(m ²)(K):		
Leading edge	-----	$7.6 \times 10^3 (w_c/w_g)^{0.49}$
Bulk	$5.6 \times 10^4 (w_c/w_g)^{0.62}$	$9.6 \times 10^3 (w_c/w_g)^{0.70}$
Coolant temperature, K	811	319
Metal wall thickness, cm	0.127	0.102
Bond coating thickness, cm	0.0102	0.0152
Ceramic coating thickness, cm	0 - 0.051	0 - 0.051

TABLE II. - THERMAL CONDUCTIVITY OF CERAMIC, BOND, AND METAL WALL MATERIALS

Material	Use	Conductivity, W/(m)(K)	Temperature range, K	Reference
MAR-M-302	Metal wall (research engine)	$4.9 \times 10^{-3} \bar{T}_{III} + 18.0$	300 - 1260	7
MAR-M-509	Metal wall (advanced core engine)	$3.0 \times 10^{-2} \bar{T}_{III} + 3.7$	590 - 1370	6
Nichrome	Bond	$8.3 \times 10^{-3} \bar{T}_{II} + 6.7$	400 - 1400	3
Calcium-stabilized zirconia	Ceramic	$4.1 \times 10^{-4} \bar{T}_I + 0.46$	400 - 2400	3

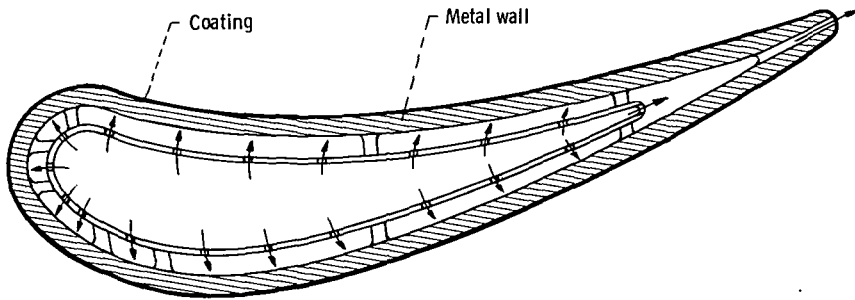

(a) Turbine vane of advanced core engine: impingement-cooled leading edge, impingement-cooled pressure and suction surfaces; convection-cooled trailing edge.

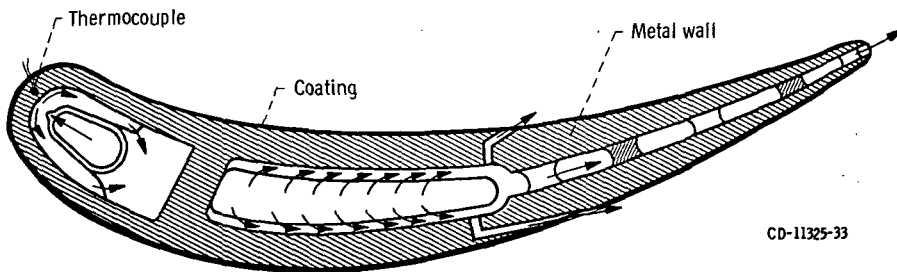

(b) Turbine vane of research engine: impingement-cooled and chordwise-finned leading edge, impingement-cooled pressure and suction surfaces; convection- and film-cooled trailing edge. (From ref. 10.)

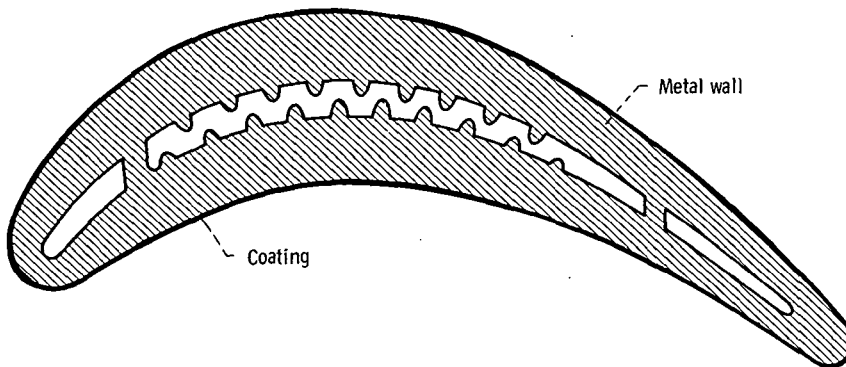

(c) Turbine blade of research engine: simple cast blade; all convection cooled. (From ref. 13.)

Figure 1. - Midspan cross sections of zirconia-coated vanes and blades used in the study.

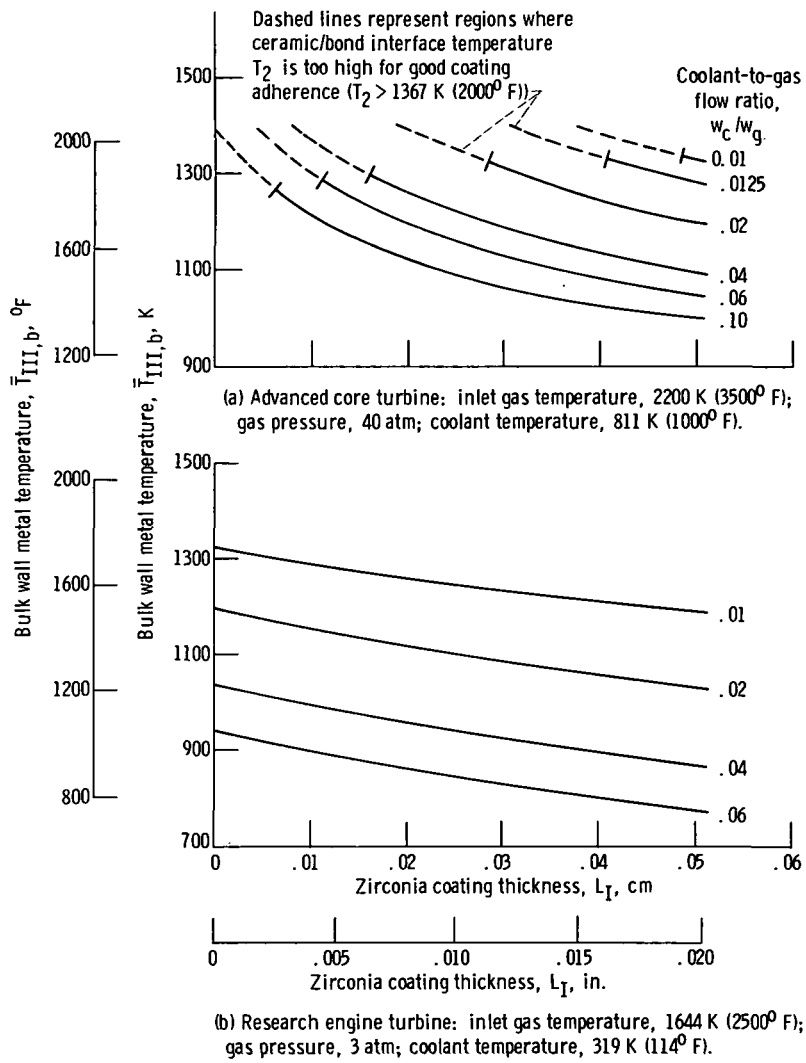

Figure 2. - Reductions in metal temperatures and coolant flows for vanes coated with various thicknesses of zirconia.

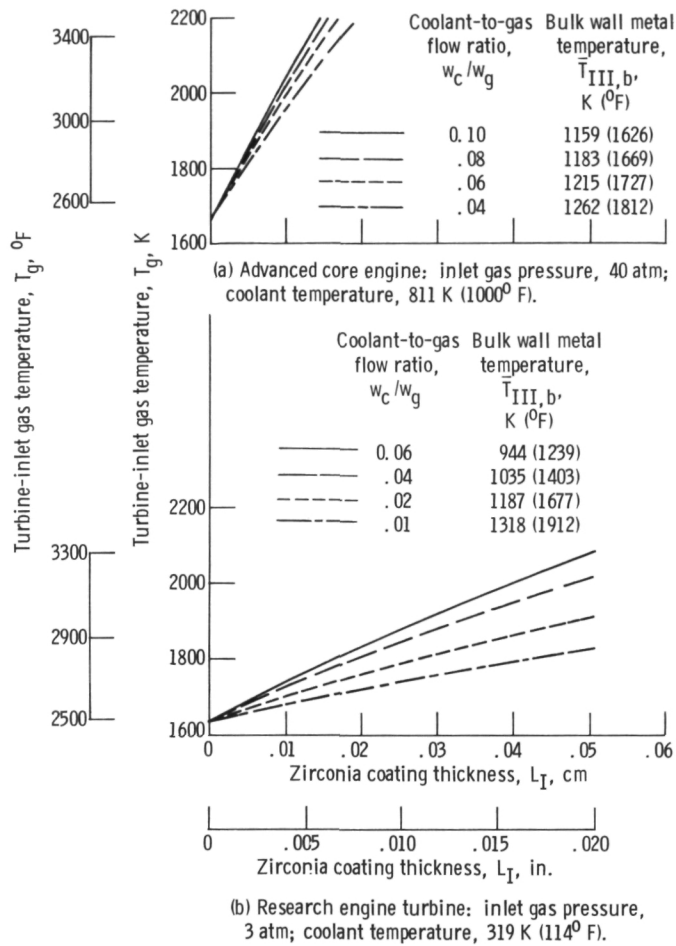

Figure 3. - Increases in allowable turbine-inlet gas temperature for vanes coated with various thicknesses of zirconia. Base turbine-inlet temperature for uncoated vanes, 1644 K (2500° F).

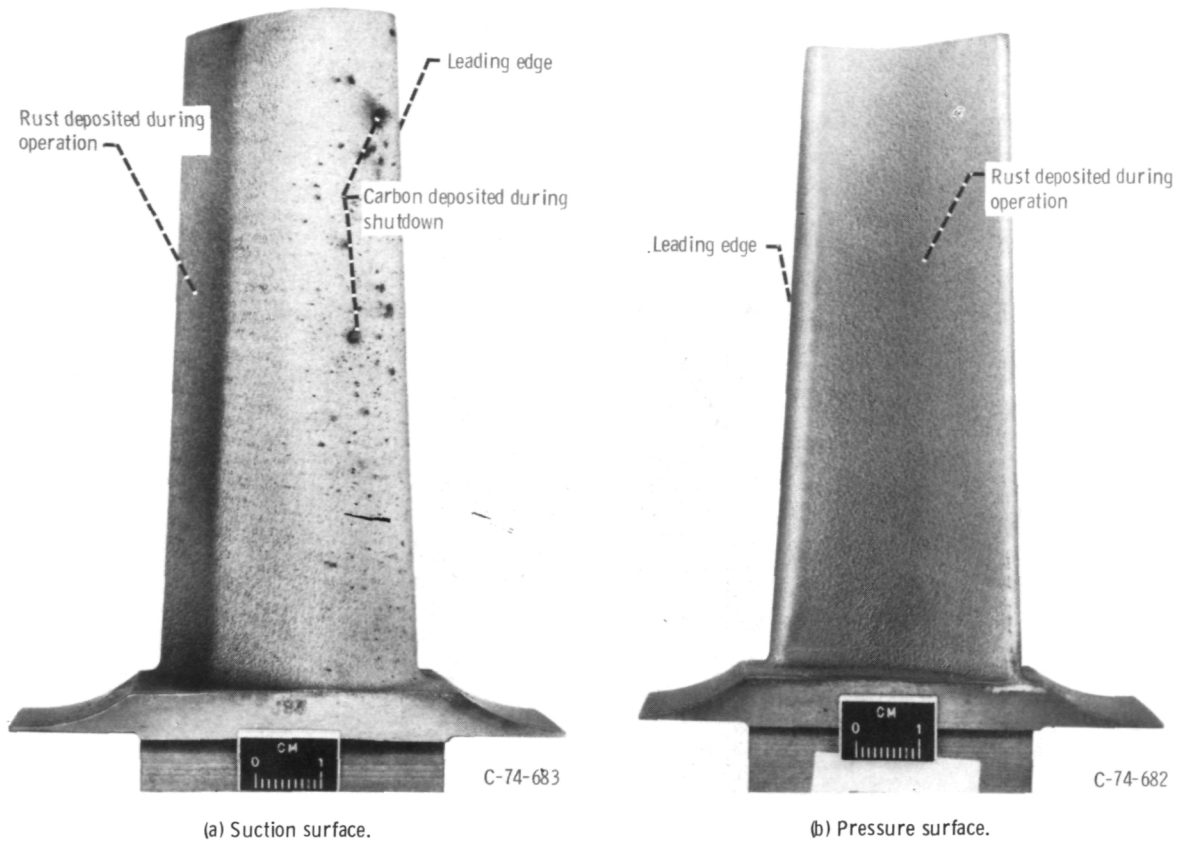

Figure 4. - Ceramic-coated blade after testing in research engine.

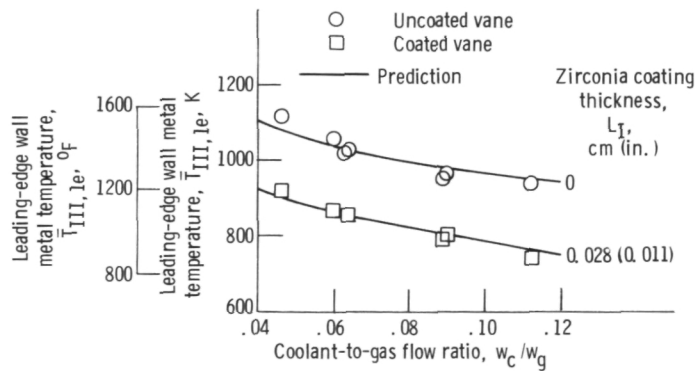

Figure 5. - Comparison of calculated and measured midspan leading-edge wall metal temperatures of uncoated and zirconia-coated turbine vanes operating in a research engine. Inlet gas temperature, 1644 K (2500° F); inlet gas pressure, 3 atm; coolant temperature, 319 K (114° F).



POSTMASTER : If Undeliverable (Section 158
Postal Manual) Do Not Return

"The aeronautical and space activities of the United States shall be conducted so as to contribute . . . to the expansion of human knowledge of phenomena in the atmosphere and space. The Administration shall provide for the widest practicable and appropriate dissemination of information concerning its activities and the results thereof."

—NATIONAL AERONAUTICS AND SPACE ACT OF 1958

NASA SCIENTIFIC AND TECHNICAL PUBLICATIONS

TECHNICAL REPORTS: Scientific and technical information considered important, complete, and a lasting contribution to existing knowledge.

TECHNICAL NOTES: Information less broad in scope but nevertheless of importance as a contribution to existing knowledge.

TECHNICAL MEMORANDUMS: Information receiving limited distribution because of preliminary data, security classification, or other reasons. Also includes conference proceedings with either limited or unlimited distribution.

CONTRACTOR REPORTS: Scientific and technical information generated under a NASA contract or grant and considered an important contribution to existing knowledge.

TECHNICAL TRANSLATIONS: Information published in a foreign language considered to merit NASA distribution in English.

SPECIAL PUBLICATIONS: Information derived from or of value to NASA activities. Publications include final reports of major projects, monographs, data compilations, handbooks, sourcebooks, and special bibliographies.

TECHNOLOGY UTILIZATION PUBLICATIONS: Information on technology used by NASA that may be of particular interest in commercial and other non-aerospace applications. Publications include Tech Briefs, Technology Utilization Reports and Technology Surveys.

Details on the availability of these publications may be obtained from:

SCIENTIFIC AND TECHNICAL INFORMATION OFFICE

NATIONAL AERONAUTICS AND SPACE ADMINISTRATION

Washington, D.C. 20546