

SP 43-27, VOL. 1

# REQUIREMENTS AND CAPABILITIES FOR PLANETARY MISSIONS: Mariner Encke Ballistic Flyby 1980

Jet Propulsion Laboratory  
California Institute of Technology  
Pasadena, California 91103

(NASA-CF-145727) REQUIREMENTS AND  
CAPABILITIES FOR PLANETARY MISSIONS:  
MARINER ENCKE BALLISTIC FLYBY 1980 (Jet  
Propulsion Lab.) 13 P HC \$3.50

CSCI 03B

G3/91

Unclas  
13609

N76-18014

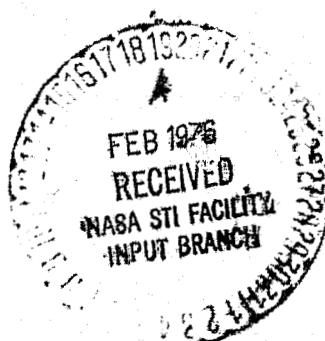

November 1975

National Aeronautics and Space Administration

## Mariner Encke Ballistic Flyby 1980

**Launch Date:** September 1980  
**Encounter Date:** November/December 1980  
**Injected Mass:** 51<sup>0</sup> kg  
**Instrument Mass:** 83 kg  
**Launch Vehicle:\*** Titan or Atlas combinations

### Objectives:

To determine the existence and character of the nucleus. To obtain first-order measurements on composition of the nucleus, coma, and tail. To map the nucleus to 100-m resolution. To study the comet's interaction with the solar media.

### Typical Science Investigations:

Mass spectrometer

\* In order to provide realistic mass numbers and propulsion requirements, specific launch vehicles have been referenced in this study; however, the use of Shuttle/IUS could be an option, depending on the time of launch and availability of the Shuttle.

Dust analyzer

Imaging

Plasma science

Magnetometer

Particle detector

Ultraviolet spectrometer

### Mission Description:

This mission provides a broad-based fast reconnaissance of comet Encke, building a data base for subsequent more detailed comet investigations, including rendezvous. After a 3-month flight, the spacecraft encounters the comet at a nominal range of about 500 km. Flyby velocity is 7 to 28 km/s depending on choice of arrival date (0 to 35 days before Encke perihelion) and launch vehicle. The spacecraft will be similar to the MVM<sup>73</sup> spacecraft, with scan platform and 117-kbps encounter data rate, designed to survive the thermal environment of 0.34 to 0.8 AU.

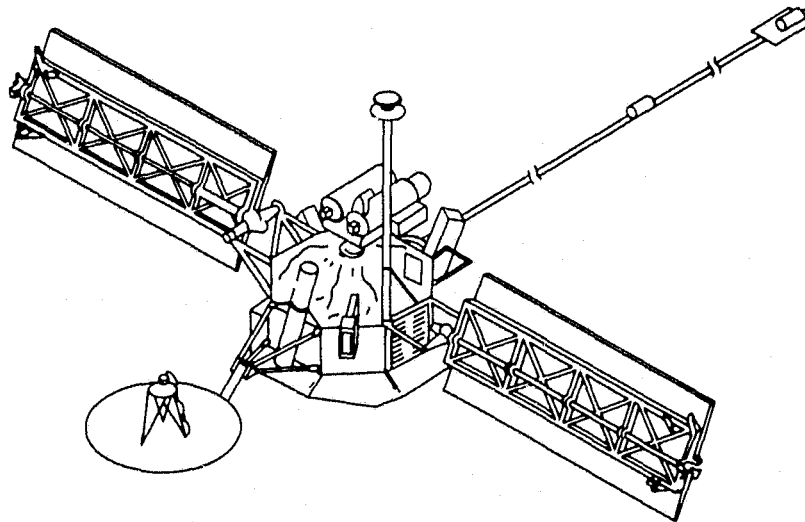

## I. Science

### A. Rationale

Knowledge of the physical conditions near a comet is very scant and is required prior to considering sophisticated rendezvous missions. A close flyby mission will provide the opportunity to determine answers to the major scientific questions regarding the nature and characteristics of the comet, and are described in more detail in the following section.

The 1980 opposition of Eneke is uniquely desirable because the Sun-Earth-Eneke geometry yields a minimum launch energy requirement and low ballistic encounter velocities. These conditions will not recur until after 1990.

### B. Objectives

Science objectives that are appropriate to a first reconnaissance mission are:

- (1) To verify the existence of a cometary nucleus and determine some principal physical properties.
- (2) To determine the composition and concentration of neutral gases, ions, and solid particles in the coma.
- (3) To determine the interaction of the comet with the solar wind.

In order to attain these objectives, the spacecraft must make *in situ* measurements in the coma and tail. Compositional measurements should be obtained close to the nucleus, within 500 km if possible, to ensure a neutral atmospheric density high enough for good mass spectroscopy and to increase the chance of measuring undissociated parent gas molecules.

Imaging of the nucleus should be from as close a distance as possible and with a resolution of 100 m or better. For maximum resolution, a phase angle of about 60 deg is desired; observations from 0 to 90 deg or more are desirable to measure the photometric function.

### C. Typical Experiments

1. **Mass spectrometer.** The investigation would be intended to provide *in situ* concentration measurements of neutral gases (including parent molecules), radicals, and ions for different parts of the coma and tail. The instrument is a double-focusing magnetic-sector type. A retarding potential is used to exclude the detection of previously measured low-velocity species from the spacecraft.

2. **Dust analyzer.** This investigation would use a time-of-flight mass spectrometer to determine the composition of the cometary dust, which would indicate the composition of the nonvolatile fraction of the nucleus. Particles are volatilized and ionized by impact or aided by capacitive discharge; the resulting ions are accelerated, allowed to drift, and timed to the terminal detector.

3. **Imaging (two TV cameras).** The cameras should provide evidence of the existence of a nucleus and, if one is found, its size, general shape, albedo, and perhaps photometric function and surface features. They should measure coma optical shape and brightness and, by using spectral filters, give data on the spatial distribution of the principal gaseous components of the coma as well as the dust.

4. **Plasma science.** This experiment would measure the electrons' refraction rate for a close pass through a comet as well as ion and electron flux. This could be accomplished with a scanning electron spectrometer and an electrostatic analyzer.

5. **Magnetometer.** This instrument should supply data on the comet-solar wind interaction. There would be two triaxial fluxgate magnetometers, separated by 2.0 m, on a 5.8-m boom for this mission.

6. **Particle detector.** This device would measure dust concentration and particle sizes. It is a capacitor-discharge impact sensor of metal-oxide-silicon structure. A meteoroid impact on the capacitor causes an electrical discharge across the oxide at the point of impact.

7. **Ultraviolet spectrometer.** This instrument, a scanning spectrometer, should supply data on the composition of the coma and tail as a function of time. The device is a concave grating, mechanical collimator.

## II. Mission Description

The Eneke 1980 mission is not difficult from a dynamical or communications viewpoint, because injection energy can be reasonably low, transit time is short, and communication distance is small relative to planetary missions. However, the relative velocity at intercept is high, as is typical for ballistic comet missions. Since the major experiments are imaging, mass spectroscopy, and particles and fields investigations, a flyby to within hundreds of kilometers of the expected nucleus is important.

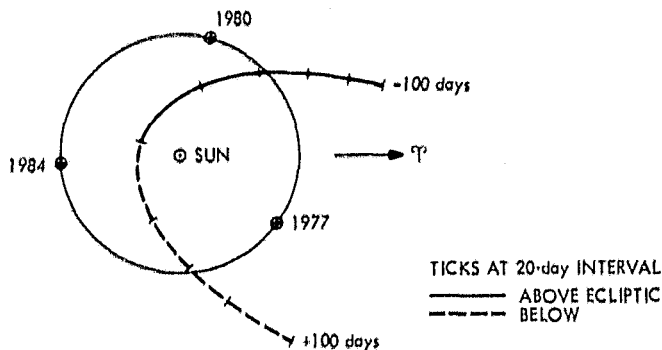

Fig. 1. Comet Encke orbit plot (ecliptic plane projection)

Figure 1 is an ecliptic plane projection of the orbit of Encke, with the position of the Earth indicated at the times of the perihelia in August 1977, December 1980, and March 1984.

Launch of the spacecraft can occur from late June to mid-September 1980. The launch vehicle could be the Atlas/Centaur/TE364, Titan III E/Centaur, or Titan IIC/TE 364-4. Choice of launch vehicle is dependent upon many factors including cost, availability, launch energy requirements, flyby velocities, and arrival dates at Encke. In general, the Titan launch vehicles will provide a considerable reduction in flyby velocity from the Atlas/Centaur launch vehicle and a significant increase in launch/arrival date ranges, and therefore is more desirable.

Because of the unique trajectory of Encke relative to the Earth, several hours of observations will be available throughout the early part of the mission. These observations will make possible the excellent comet orbit determination that is required for the precision targeting at encounter.

Since the communication distance ranges from 44 to 150 million km, depending on encounter date, the NASA 26-m antenna Deep Space Network is sufficient for most cruise operations, with the 64-m network required during the encounter operations for the high data rates (117,000 bits/s) needed for real-time imaging. Table 1 illustrates some of the key mission parameters for this first mission, assuming either the Atlas/Centaur/TE364 or the Titan Centaur launch vehicle.

While targeting accuracy requirements will not be any more stringent than typical planetary encounters, the errors associated with the comet ephemeris are large, thus requiring both on-board and ground-based measurements. An Earth-based comet observation network will have to

be put into operation to provide near-continuous systematic observations of the comet during the mission. The first trajectory correction maneuver, about 1 week after launch, corrects for the launch injection errors; the second, 3 to 6 weeks before encounter, must redirect the spacecraft trajectory based upon the latest ephemeris data from the comet observation network. A third correction, that may be required a few days from encounter, would be based on Earth and spacecraft optical tracking of the comet.

A typical encounter profile is shown in Table 2.

Detection of the comet's coma by the sensitive short-focal-length, large-aperture 500-mm camera will occur about 2 to 3 weeks prior to encounter. Several days later, the nucleus will be detected as a point source by the same camera. At this time, several images of the nucleus with a star background could be taken to be used for optical approach guidance purposes. Within a day or two of taking and analyzing these images and merging the data with the ground-based observations, a trajectory correction maneuver could be performed. The spacecraft will then be on a trajectory that will take it as close to the nucleus as desirable within the navigation error constraints.

Periodic mosaicking of the comet will begin several days from encounter to provide time-lapse photography that will be helpful in understanding the comet's coma dynamics. Still several days before encounter, solid particles from the comet will begin to be recorded as an increase of impacts on the particle detectors.

Possibly as early as 10 h before closest approach, the plasma and fields experiments will observe the comet's bow shock if it exists. The magnetometers will measure the magnetic field magnitude and direction across the shock, while the plasma science experiment will measure electron and ion densities, velocities, and temperature across the shock and transition region.

Before coma penetration at encounter minus 45 min, the long-focal-length camera will begin to resolve a 4-km-diameter nucleus, if one exists, at the center of the comet. The nucleus will appear as a nearly fully-lit disc and should provide basic information on size and shape even though it is at a range of 38,000 km. Penetration of the gaseous coma of the comet will occur about 17 min before encounter. At this time, molecular densities of some primary constituents and their radicals and ions will become detectable by the mass spectrometer.

**Table 1. Mariner Encke 1980 launch vehicle comparison**

Parameter	Atlas/Centaur/TE 364 <sup>a</sup>	Titan III-F/Centaur	Titan III-C/TE 364-4
Launch period	Aug. 14, 1980	June 28 to Sept. 15, 1980	July 3 to Sept. 7, 1980
Launch energy (C <sub>3</sub> ), km <sup>2</sup> /s <sup>2</sup>	50	1 to 100	1 to 80
Encounter date	Nov. 12, 1980	Nov. 2 to Dec. 6, 1980	Nov. 3 to 24/Dec. 6, 1980
Encounter time, days from Encke perihelion	-26	-35 to 0	-34 to -12
Communication distance at encounter, million km	61	44 to 150	45 to 98/150
Solar distance at encounter, AU	0.73	0.87 to 0.34	0.85 to 0.70/0.34
Approach velocity, km/s	25	32 to 7	31 to 16/10 to 20
Mission duration, days	71	48 to 135	54 to 125/89 to 116

<sup>a</sup>Marginal

**Table 2. Encounter profile<sup>a</sup>**

Event	Time	Distance, km
Begin UV observations	From launch	$270 \cdot 10^6$
Detect comet with TV	E - 16 days	$2 \cdot 10^7$
Detect nucleus as point source	E - 9 days	$10^7$
Begin periodic comet photography	E - 4 days	$5 \cdot 10^6$
Earliest bow shock	E - 10 h	$5 \cdot 10^5$
Nucleus <sup>b</sup> is >10 pixels diam.	E - 45 min	38,000
Penetrate gaseous coma	E - 17 min	15,000
100-m resolution of nucleus	E - 6 min	5,000

<sup>a</sup>Assumes Aug. 27, 1980, launch; Nov. 27, 1980, encounter; and 14-km/s flyby.  
<sup>b</sup>If nucleus is 4 km in diameter.

The nucleus surface resolution will continue to increase until several minutes before encounter. Both cameras should obtain nucleus surface resolution of at least 100 m. This resolution corresponds to a resolution higher by about a factor of 5 than that obtained by Mariner 9 of the Martian satellites Phobos and Deimos.

Post-encounter will proceed in a similar manner as the pre-encounter time-line except that the phase angle of the comet nucleus may be too large to allow continued safe observations by the television and UV experiments.

### III. General Spacecraft Characteristics

The Mariner Encke 80 (Fig. 2) spacecraft is almost identical to the MVM'73 spacecraft, differing only in the complement of scientific instruments.

#### A. General Description

In common with earlier Mariner spacecraft, ME80 uses solar cells and batteries for electrical power; three-axis attitude stabilization; celestial references; nitrogen gas for reaction control; S-band radio for command, telemetry, and ranging; a high-gain antenna; a scan platform for

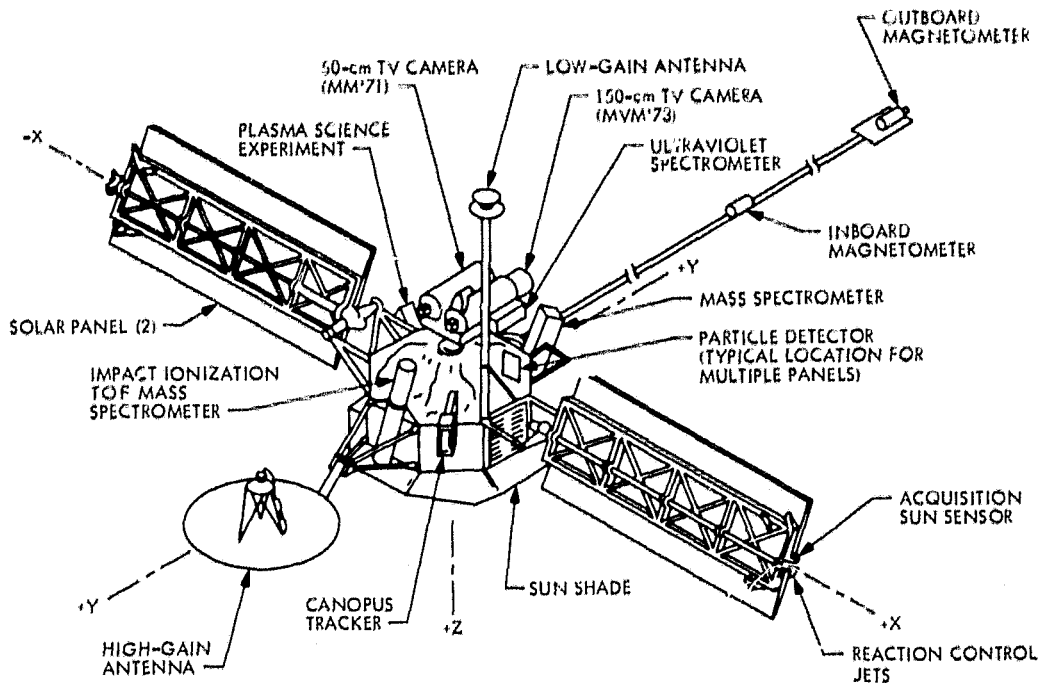

Fig. 2. Spacecraft configuration

science instrument pointing; a hydrazine propulsion module; and an octagonal main structure.

The skeleton of the ME80 spacecraft is an octagonal magnesium structure, approximately 45.7 cm high and 127 cm across the flats. It supports all appendages, provides a structural foundation for subsystem and assemblies, houses the major electrical/electronic subsystems of the spacecraft in its eight bays, and provides an interface plane to which the forward payload adapter (mounting interface with the launch vehicle) is attached.

The spacecraft flight configuration is shown in Fig. 2. The ME80 weighs 508 kg with the baseline payload and full fuel and attitude control gas tanks. In its flight configuration, the spacecraft is 3.7 m high, 8.0 m across the X-X axis, and 9.9 m across the Y-Y axis.

### B. External Equipment

Attached to the octagon via outriggers are deployable solar panels that articulate around booms oriented along the X-X axis. These arrays, which are 5.2 m<sup>2</sup> in area, provide 539 W at Earth and 480 W at Encke encounter. They can be rotated from 0 to 78 deg to the sunline for thermal control. In a similar manner, a deployable high-gain antenna boom supporting a 1.4-m diameter, 2-degree-of-freedom S-band antenna is attached to the +Y side of

the spacecraft. A deployable boom, 6 m long, is oriented along the Y axis, with a dual sensor magnetometer attached.

Along the Sun-facing +Z axis is a propulsion module that is attached to the octagon. The module is completely self-contained, except for engine valve drive and telemetry electrical interfaces. It employs a blowdown concept and catalytic engine to provide a total velocity impulse of 120 m/s from 29 kg of hydrazine. Jet vanes immersed in the engine exhaust are used for thrust vector control.

Covering the propulsion module and extending beyond the octagon bay faces is a deployable spacecraft sunshade. This is the most forward-facing spacecraft assembly and, except for the engine opening, completely shades the spacecraft bus and experiment extending from the bus (which must not directly face the Sun for extended periods). The sunshade is attached to the lower octagon ring and is deployed after separation from the launch vehicle.

Occupying the antisun-facing spacecraft axis (-Z) is the 2-degree-of-freedom scan platform. A housing attached to the octagon by a structural spider and tubular supports provides bearing and alignment for the platform. The platform supports two television cameras, their auxiliary

electronics, and the ultraviolet spectrometer. It can be positioned between 25 and 270 deg in clock and 58 to 180 deg in cone.

This antisun-facing side also supports the 1.5-m long low-gain antenna used primarily for command reception, though it is capable of sending low-rate telemetry. The LGA moves through three positions. Position 1 is the launch position, in which the spring-loaded antenna is rotated 15 deg inwardly so that it can be tied together with the solar panels and magnetometer boom. Position 2, parallel to the -Z axis, is the latched position through Eneke encounter. The final position, position 3 (95 deg cone and 354 deg clock), is available by command if needed.

Symmetrically located about the spacecraft are two identical reaction-control assembly half-systems, each capable of supporting the mission if one half-system fails. Roll and yaw jets are fastened to the solar panel boom tips, and pitch jets are fastened to the outriggers. Small rigid and flexible stainless-steel tubing connects these jets to the two N<sub>2</sub> gas supply tanks supported on the octagon's -Z face. These contain a 3.63-kg N<sub>2</sub> gas supply.

Nonimaging science, celestial sensors, and thermal blankets and shields complete the complement of significant external equipment. (The proposed science payload is described in Section IV.) The celestial sensors—Canopus tracker, acquisition Sun sensor, Sun gate, and cruise Sun sensor—are so located on the spacecraft as to meet their respective viewing requirements. The Canopus tracker, which by definition establishes the 0-deg clock position, is attached to the -Z octagon at 60 deg to the +X axis in the direction of the +Y axis and boresighted to a 90-deg cone angle. On one outrigger, aligned to the Z-Z axis in the direction of the Sun, are the cruise Sun sensors and Sun gate. The acquisition Sun sensors are located at the ends of the +X and -X solar panels.

Thermal blankets, shields, and louvers are used wherever necessary to maintain temperature control. Thermal blankets (cut out as required) cover the magnetometer, HGA and PSE booms, NIS housings, Canopus tracker, and propulsion module, including the +Z face of the octagon. Thermal shields are used to protect science sensors, reaction control jets, thrust vector control assembly, and the bay faces. Louvers, automatically adjusted by bimetallic springs, cover five bays. These faces cannot be exposed to the Sun during maneuvers.

## B. Internal Equipment

Housed within the eight bays of the octagon is an assortment of electrical/electronic equipment, interconnected by electrical cable harnesses. This equipment, in conjunction with the external equipment, provides electrical power, command and control, attitude, data acquisition, telemetry, and a trajectory-correction capability.

The power conditioning, storage, and distribution equipment is located in three bays. The modulation-demodulation subsystem occupies a portion of one of these bays. The MDS decodes and directs the 96 ground-transmitted commands, and modulates the subcarriers with the engineering and science data.

One bay houses the radio frequency subsystem, receives ground commands, and transmits data to the Deep Space Network ground stations. Another bay houses the data storage subsystem, a tape recorder, and its electronics, which store data for later transmission.

One bay houses the flight data subsystem, which formats engineering and science data streams, and aids in sequencing the science instruments. Its many data modes are tailored to the various mission phases to provide for efficient transmission of data. Some elements of the data format may be reprogrammed by ground command.

One bay houses much of the science instrument electronics and also the articulation and pointing electronics, which controls the actuators to move the solar panels, scan platform, and HGA. Some instrument electronics is located within the instruments.

One bay houses the attitude control electronics and the central computer and sequencer. The ACE senses the spacecraft position and motion, and directs the RCA to properly position the spacecraft or to change its position for trajectory correction maneuvers. The CC&S is a general-purpose computer, which processes and stores commands and initiates events at pre-established times.

Mass and power summaries are provided in Tables 3 and 4. Telemetry error rates for the high data rate link are shown in Fig. 3.

## IV. Mission Options

Several mission options are available for the Eneke ballistic mission. One option would be to have a Helios-

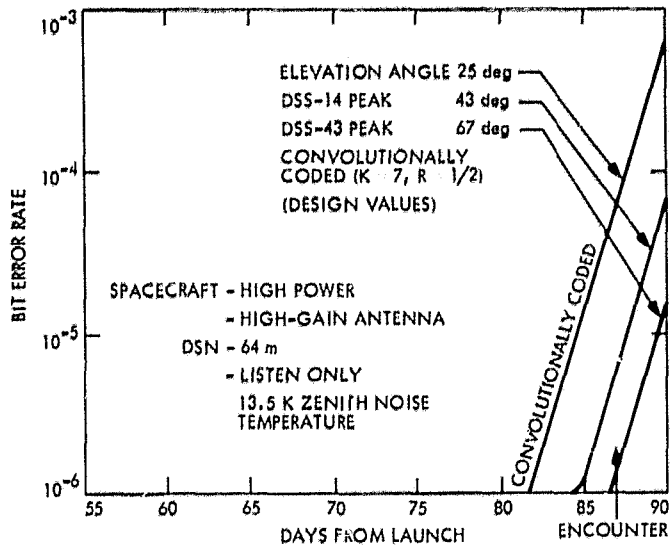

Figure 3. Mariner Encke 1980 117.6-kbps telemetry error rate vs days from launch

C/Mariner Encke combined launch. A Titan/Centaur would be used to send up the two spacecraft in a single launch. Both spacecraft would be targeted for Eneke. The Mariner spacecraft would provide approach guidance for Helios. Helios would investigate the tail region and carry on some solid particle analysis. Mariner's primary mission would be to carry on imaging and mass spectroscopy of the comet.

Another choice would allow a Mercury flyby in September 1981 after the spacecraft's encounter with Eneke in December 1980. A  $\Delta V$  of 1.5 km/s would be required to make this change.

In addition, a second encounter of Eneke by a MVM spacecraft could be an option in 1984. Also, a flyby of Geographos in 1983, after the first Eneke encounter in 1980, would be possible. Geographos is a member of the

Table 3. Encke Weight Summary

Subsystem	Mass, kg
Structure	134.8
RFS Bay 4	24.3
MDS Bay 2	8.3
PWR Bays 1, 2, and 8	72.2
CC&S Bay 7	9.9
FDS Bay 3	14.5
ACS	30.4
PYRO	4.0
Cabling	39.7
Propulsion (dry)	12.6
Temperature control	17.8
Mechanical devices	29.1
APS	12.8
DSS	10.5
S-band antennas	2.5
PSE	9.7
UVS	3.5
MAGs	11.4
TV	44.0
Mass spectrometer	6.0
Dust analyzer	6.0
CPD	5.0
Dry mass + I-PA	509.1
Dry mass	478.6
Launch mass	538.2
Separated spacecraft mass	507.7

Apollo group of asteroids. This type of asteroid has its perihelion at Earth orbital distance and aphelion in the Asteroid Belt. A small  $\Delta V$  of less than 100 m/s may be necessary to accomplish this goal.



Table 4. Encke power allocation, W

Mission phase	ICM	Cruise	Encounter
<b>2.4-kHz loads</b>			
1/NMS	10,00	10,00	10,00
101 MS	8,00	8,00	8,00
TV	0,00	0,00	30,90
UVS	2,00	2,00	2,00
CPD	1,00	1,00	1,00
MAG	9,57	9,57	9,57
PSE	6,60	6,60	6,60
APS	13,30	13,30	15,90
ACS	48,80	8,50	29,50
DSS	15,30	9,80	22,00
FDS	25,40	25,40	23,40
CC&S	19,30	17,60	19,30
MDS	6,10	6,10	6,10
RFS	22,60	22,60	22,60
PYRO	0,30	0,30	0,30
PWR (dist)	14,00	14,00	14,00
2.4-kHz load (out)	202,27	154,77	223,17
<b>Booster reg. loads</b>			
2.4-kHz inv. (in)	221,00	171,63	243,07
2.4-kHz inv. efficiency	0,915	0,902	0,918
Gyro-400 Hz	9,90	0,00	9,90
PWR (dist)	7,40	7,40	7,40
Total B/R load (out)	238,30	179,03	260,37
<b>30-Vdc reg. loads</b>			
PYRO/prop.	56,00	0,00	0,00
30-V preload	12,00	0,00	0,00
30-Vdc reg. loads	68,00	,00	0,00
<b>Unregulated power</b>			
B/R (in)	271,21	198,29	287,01
B/R efficient	0,879	0,903	0,907
30-Vdc reg. (in)	81,23	0,00	0,00
30-Vdc conv. efficiency	0,837	0,000	0,000
Battery charger	0,00	33,40	0,00
TWT-S	55,10	55,10	91,80
TWT-X	10,60	10,60	0,00
TV replacement heater	0,00	6,30	0,00
TV optics heater	8,53	18,20	18,20
B/R Sensor	1,50	1,50	1,50
Bay 6 and 7 heaters	0,00	14,94	0,00
Supplementary heaters	31,30	85,28	0,00
Total unreg. load	459,46	423,59	398,51
Total power, w	483,65	436,69	410,83
EFF (on battery) = 0.95			
EFF (on solar panel) = 0.97			

ORIGINAL PAGE IS  
OF POOR QUALITY

## Abbreviations and Acronyms

ACE	attitude control electronics	MAI	magnetometer
ACS	attitude control subsystem	MDS	modulation/demodulation subsystem
APE	articulation and pointing electronics	ME80	Mariner Eneke 1980
APS	articulation and pointing subsystem	MM'71	Mariner Mars 1971
B/R	booster regulator	MVM'73	Mariner Venus/Mercury 1973
CC&S	central computer and sequencer	NIS	nonimaging science
CPD	comet particle detector	PSE	plasma science experiment
DSN	Deep Space Network	PWR	power
DSS	data storage subsystem, Deep Space Station	PYRO	pyrotechnic devices
EFF	efficiency	RCA	reaction control assembly
FDS	flight data subsystem	RFS	radio frequency subsystem
FPA	forward payload adapter	TCM	trajectory correction maneuver
HGA	high-gain antenna	TOFMS	time of flight mass spectrometer
I/NMS	ion/neutral mass spectrometer	TV	television
LGA	low-gain antenna	TWT	traveling wave tube
		UVS	ultraviolet subsystem, ultraviolet spectrometer

## Bibliography

- Atkins, K. L., and Moore, J. W., "Cometary Exploration: A Case for Encke," AIAA paper No. 73-596, 1975.
- Lyttleton, R. A., *The Comets and Their Origin*, Cambridge Univ. Press, 1953.
- Marsden, B. G., and Sekanina, Z., "Comets and Navigational Forces. VI. Periodic Comet Encke 1786-1971," *Astron. J.*, Vol. 79, pp. 413-49, March 1974.
- Noek, K. T., and Yeates, C. M., *Early Mariner Comet Flyby*, American Institute of Aeronautics and Astronautics, 75-198, January 20, 1974.
- Oort, J. H., "Empirical Data on the Origin of Comets," in *The Moon, Meteorites, and Comets*, ed. by B. M. Middlehurst and G. P. Kuiper. Univ. of Chicago Press, Chicago, 1963.
- Whipple, F. L., "On the Structure of the Cometary Nucleus," in *The Moon, Meteorites, and Comets*, ed. by B. M. Middlehurst and G. P. Kuiper, Univ. of Chicago Press, Chicago, 1963.
- "A Program of Study," *The 1973 Report and Recommendations of the NASA Science Advisory Committee on Comets and Asteroids*, NASA TM-X-71917.
- A Report of the Comet Encke Ballistic Engineering Panel*, GSFC, JPL, ARC, 1974 (partial draft).
- Mariner Encke 1980 Study Report*, JPL, 660-7, June 30, 1975 (JPL internal document).
- Mysteries of the Solar System*, Clarendon Press Oxford, 1968.
- NASA Comet Seminar, meetings in Washington, D.C., and Cambridge, Mass., during 1973-1974 (no proceedings planned).
- Planetary Mission Summary: Mariner Encke Ballistic Flyby 1980*, JPL SP 43-10, Vol. 10, August 1974.
- Proceedings of the Cometary Science Working Group*, ed. by D. L. Roberts, Yerkes Observatory, June 1971.
- 1980 Mariner Encke Mission Presentation*, JPL, 662-1, April 25, 1975 (JPL internal document).