

**NASA TECHNICAL
MEMORANDUM**



NASA TM X-3347

NASA TM X-3347

**EFFECT OF CASING TREATMENT
ON PERFORMANCE OF AN INLET STAGE
FOR A TRANSONIC MULTISTAGE COMPRESSOR**

*Donald C. Urasek, George W. Lewis, Jr.,
and Royce D. Moore*

*Lewis Research Center
Cleveland, Ohio 44135*



NATIONAL AERONAUTICS AND SPACE ADMINISTRATION • WASHINGTON, D. C. • FEBRUARY 1976

1. Report No. NASA TM X-3347	2. Government Accession No.	3. Recipient's Catalog No.	
4. Title and Subtitle EFFECT OF CASING TREATMENT ON PERFORMANCE OF AN INLET STAGE FOR A TRANSONIC MULTISTAGE COMPRESSOR		5. Report Date February 1976	
		6. Performing Organization Code	
7. Author(s) Donald C. Urasek, George W. Lewis, Jr., and Royce D. Moore		8. Performing Organization Report No. E-8183	
		10. Work Unit No. 505-04	
9. Performing Organization Name and Address Lewis Research Center National Aeronautics and Space Administration Cleveland, Ohio 44135		11. Contract or Grant No.	
		13. Type of Report and Period Covered Technical Memorandum	
12. Sponsoring Agency Name and Address National Aeronautics and Space Administration Washington, D. C. 20546		14. Sponsoring Agency Code	
		15. Supplementary Notes	
16. Abstract An inlet stage of a transonic compressor was tested with three rotor tip casing treatment configurations; blade angle slots, circumferential grooves, and axial skewed slots. Significant increases in both rotor and stage total pressure ratio, total temperature ratio, efficiency, flow range, and very large improvements in stall margin were obtained with all three casing treatment configurations. The greatest improvement in performance was achieved with axial skewed slots.			
17. Key Words (Suggested by Author(s)) Turbomachinery Compressor Axial flow		18. Distribution Statement Unclassified - unlimited STAR Category 02 (rev.)	
19. Security Classif. (of this report) Unclassified	20. Security Classif. (of this page) Unclassified	21. No. of Pages 125	22. Price* \$5.25

* For sale by the National Technical Information Service, Springfield, Virginia 22161

EFFECT OF CASING TREATMENT ON PERFORMANCE OF AN INLET
STAGE FOR A TRANSONIC MULTISTAGE COMPRESSOR
by Donald C. Urasek, George W. Lewis, Jr. , and Royce D. Moore
Lewis Research Center

SUMMARY

The first stage of a transonic multistage compressor was tested with three rotor tip casing treatment configurations; blade angle slots, circumferential grooves, and axial skewed slots. Radial surveys of the flow conditions upstream of the inlet guide vanes (IGV's), between the IGV's and rotor, between the rotor and stator, and behind the stator were made over the stable operating flow range of the stage at the design blade tip speed of 425 meters per second. The surveys were taken at 11 radial positions. The results of this casing treatment investigation substantiate the results from a previous study in that casing treatment has a pronounced effect on improving the performance of rotors and stages which are rotor tip critical. Significant increases in both rotor and stage total pressure ratio, total temperature ratio, efficiency, flow range, and very large improvements in stall margin were obtained with all three casing treatment configurations. The greatest improvement in performance was achieved with axial skewed slots.

INTRODUCTION

The NASA Lewis Research Center is engaged in a research program on axial-flow compressors for advanced airbreathing engines. The program is directed primarily towards providing the technology to permit reducing the size and weight of the compressor while maintaining a high level of performance. In support of this program a 51-centimeter-diameter, five-stage compressor designed for a mass flow of 29.7 kilograms per second and a pressure ratio of 9.27 was fabricated and tested.

Data obtained from initial tests of the five stage indicated that the first stage was not meeting its intended performance. To more completely map the performance of this first stage, it was tested separately in the Lewis single-stage test facility. The aero-

dynamic performance of this stage is presented in reference 1. The test results showed that the first stage rotor was low in flow range, pressure ratio, and efficiency. The rotor appeared to be tip critical; that is, blade elements in the tip region reach a critical operating condition and stall before the remaining elements. The rotor tip did not pass the flow forcing a redistribution of flow in the blade passage. The stall margin was only 8 percent.

Rotor casing treatments have been fairly successful with rotors having tip critical conditions. One such successful experiment is discussed in reference 2. To evaluate the effect of rotor casing treatment on the performance of this stage, an experimental study was undertaken.

This report presents the performance of the first stage of the five-stage compressor with three separate rotor casing treatment configurations. The stage was tested with inlet guide vanes which were set for zero turning (axial discharge). The data are presented over the stable operating flow range of the stage at design speed. Surveys of the flow conditions were taken at 11 radial positions. The data presented in this report are in tabular as well as in plotted form. The symbols are defined and the equations are given in appendixes A and B. The definitions and units used for the tabular data are presented in appendix C.

AERODYNAMIC DESIGN

Three computer programs were used in the design of the five-stage compressor. These programs are (1) streamline analysis program, (2) blade geometry program, and (3) blade coordinate program. These three computer programs are presented in detail in references 3 and 4 and only a brief description of each is presented in this report.

The streamline analysis program was used to calculate the flow field parameters at several axial locations including radial planes approximating the blade leading and trailing edges for both the rotor and stator. The weight flow, rotative speed, flow path geometry, and radial distributions of total pressure and temperature are inputs to this program. The program accounts for both streamline curvature and entropy gradients; boundary layer blockage factors are also included.

The distributions of velocity, total pressure, and total temperature calculated in the streamline analysis program are utilized in the blade geometry program to compute blade geometry parameters. Total loss for the blades was primarily based on the experimental rotor loss data presented in reference 3 with modifications due to influences of other unreported test data. The profile loss was then estimated by subtracting a calculated shock loss from the total loss. The shock loss calculation was based on the method presented in reference 5.

The blade geometry parameters are utilized in the blade coordinate program (ref. 4) to compute blade elements on conical surfaces passing through the blade row. In this program the blade elements are then stacked on a line passing through their centers of gravity and cartesian blade coordinates are computed which are used directly in fabrication.

The overall design parameters for the rotor and stage are listed in table I and the flow path is shown in figure 1. For the single-stage compressor tests, the flow area downstream of the stator was enlarged to pass the required weight flow; otherwise, the flow path was unchanged. This stage was designed for an overall pressure ratio of 1.61 at a weight flow of 29.7 kilograms per second (196 (kg/sec)/m² of annulus area). The design tip speed was 425 meters per second. The rotor and stator were designed for tip solidities of 1.4 and 1.5, respectively. The rotor had 57 blades with an aspect ratio of 3.1 and the stator had 64 blades with an aspect ratio of 2.7.

The blade-element design parameters for the rotor are presented in table II. This rotor was designed for a radially constant total pressure ratio of 1.62. The stator blade element design parameters are given in table III. The blade geometry is presented in table IV for the rotor and in table V for the stator. The rotor has multiple circular-arc blade shapes while the stator has a double circular-arc blade shape.

The equations used for calculating overall and blade-element performance parameters are presented in appendix B and all definitions and units presented in the tabulation tables are given in appendix C.

A sketch of the inlet guide vane (IGV) together with profile coordinates are shown in figure 2. The vanes utilized multiple circular-arc blade profiles. There were 26 vanes having a tip solidity of 1.0 and an aspect ratio of 2.4. All tests were conducted with the vanes aligned in the axial direction.

APPARATUS AND PROCEDURE

Compressor Test Facility

The compressor stage was tested in the single-stage compressor test facility at the Lewis Research Center. A schematic diagram of the facility is shown in figure 3.

Atmospheric air enters the test facility through an inlet located on the roof of the building, flows through the flow measuring orifice, and into the plenum chamber upstream of the test stage. The air then passes through the experimental compressor stage into the collector and is exhausted to the atmosphere. Weight flow is controlled with a sleeve valve in the collector.

Test Stage

Photographs of the tested IGV, rotor, and stator are shown in figure 4. The rotor blades have vibration dampers located at about 40 percent span from the rotor tip. The maximum thickness of the damper is 0.180 centimeter. The nonrotating radial tip clearance of the rotor was a nominal 0.05 centimeter at ambient conditions. To accommodate survey instrumentation, the axial spacing between the IGV hub trailing edge and rotor hub leading edge was 2.50 centimeters. The axial spacing between the rotor hub trailing edge and the stator hub leading edge was 2.66 centimeters.

Casing Treatment Inserts

Blade-angle slot insert. - The slots, which were at the same angle as the blade-tip setting angle ($\sim 63^{\circ}$), extended radially into the casing. The slots are shown in figure 5. Also shown in the figure are a photograph of the relative location of the slots to the rotor blade and a photograph of the slot insert. The bottoms of the slots were closed to avoid slot to slot recirculation of air. Based on the results presented in reference 2, the slots cover only the midportion of the blades (approximately 50 percent of blade tip axial chord).

Circumferential grooved insert. - The circumferentially grooved insert is shown in figure 6. Included in the figure are a photograph of the relative location of the slots with respect to the rotor blade and a photograph of the insert. The grooves extended only over the midportion of the blades (approximately 70 percent of blade tip axial chord). With circumferential grooves, the rear-to-forward recirculation is minimized, but blade-to-blade recirculation occurs in the circumferential direction.

Axial skewed slot insert. - The skewed slots are parallel to the axial direction and skewed in the direction of rotation. The axial skewed slots are shown in figure 7. A photograph of the relative location of the slots with respect to the rotor blade and a photograph of the insert are included in the figure. Like the other inserts, the slots cover only the midportion of the blades (approximately 50 percent of blade tip axial chord). The bottoms of the slots were closed to avoid slot to slot recirculation of air.

Instrumentation

The compressor weight flow was determined by means of a calibrated thin-plate orifice. The orifice temperature was determined with Chromel-constantan thermocouples. Orifice pressures were measured with calibrated transducers.

Radial surveys of the flow were made upstream of the inlet guide vanes (IGV's), between the IGV's and rotor, between the rotor and stator, and downstream of the stator. Two combination survey probes at each station were used to measure total pressure and total temperature. Flow angles were measured upstream of the IGV, between the IGV and rotor, and downstream of the stator. A photograph of the combination probe is shown in figure 8. Each probe was positioned with a null-balancing, stream-directional sensitive control system that automatically alined the probe to the direction of flow. The probes were angularly alined in an air tunnel prior to testing. The thermocouple materials were Chromel-constantan.

The circumferential locations of the two survey probes, at each of the four measuring stations are shown in figure 9. The probes between the IGV's and rotor, and downstream of the stator were circumferentially traversed one blade passage counterclockwise from the nominal values shown. One IGV blade passage is 13.87° and one stator blade passage is 5.63° .

An electronic speed counter, in conjunction with a magnetic pickup, was used to measure rotative speed (rpm).

The estimated errors of the data based on inherent accuracies of the instrumentation and recording system are as follows:

Flow rate, kg/sec	0.3
Rotative speed, rpm	30
Flow angle, deg	1
Temperature, K	0.6
Guide vane inlet total pressure, N/cm^2	0.01
Rotor inlet total pressure, N/cm^2	0.01
Rotor outlet total pressure, N/cm^2	0.10
Stator outlet total pressure, N/cm^2	0.10

Test Procedure

The stage survey data were taken at five weight flows ranging from maximum flow attainable to the near-stall conditions at design speed for each insert configuration. Data were recorded at 11 radial positions for each weight flow.

At each radial position the combination probes behind both the IGV's and stator blades were circumferentially traversed to nine different locations to cover one complete blade gap. Values of total pressure, total temperature, and flow angle were recorded at each circumferential position. At the last circumferential position, values of total pressure, total temperature, and flow angle upstream of the IGV's and total pressure and total temperature between the rotor and stator were also recorded. All probes were

then traversed to the next radial position and the circumferential traverse procedure repeated.

The back pressure on the stage was increased by closing the sleeve valve in the collector until a stalled condition was detected by a sudden drop in stage outlet total pressure. This pressure was measured by a probe located at midpassage of the annulus and was recorded on an X-Y plotter. Stall was corroborated with a sudden increase in noise level.

Calculation Procedure

Data were reduced using a streamline-analysis computer program which calculated static pressures at each measuring station and flow angles at the station behind the rotating blade row. The inputs to this program include corrected weight flow, corrected speed, total pressure, and total temperature behind the rotating blade row and weight flow, total pressure, total temperature, and flow angle behind the fixed blade row. Static pressure is calculated within the program from considerations of continuity of mass flow and radial equilibrium which includes streamline curvature terms.

At each radial position nine circumferential values of total temperature, total pressure, and flow angle across both the IGV and stator gaps were area averaged. The data, measured at the four measuring stations, were then translated to the blade leading and trailing edges by the method presented in reference 3. Orifice weight flow, total pressure, static pressure, and temperatures were all corrected to standard sea-level conditions at the IGV inlet.

RESULTS AND DISCUSSION

The results from this investigation are presented in three main sections: (1) overall performance for the rotor and stage, (2) radial distributions of various performance parameters for the IGV, rotor and stator with the solid casing (from ref. 1) and axial skewed slots, and (3) blade-element data for both rotor and stator with solid casing and the three rotor casing treatments. The data presented are computer plotted; occasionally a data point falls outside the range of parameters shown in the figure and is omitted.

All of the plotted data together with some additional performance parameters are also presented in tabular form. The overall performance data for the rotor and the stage are presented in table VI. The blade-element data are presented for the IGV, rotor, and stator in tables VII, VIII, and IX, respectively. The definitions and units used for the tabular data are presented in appendix C.

Overall Performance

The overall performance of the rotor and the stage are presented for the three rotor casing treatments in figures 10 and 11, respectively. The results are compared at design speed with the solid casing data from reference 1. Data are presented at several weight flows from the maximum attainable to the near-stall condition. Design point values are shown as solid symbols.

In figures 10 and 11, averaged values of total pressure ratio, total temperature ratio, and temperature rise efficiency are plotted as a function of equivalent weight flow. Significant increases in flow range, total pressure ratio, total temperature ratio, and efficiency were realized with all three rotor casing treatments.

One exception was noted where stage overall efficiency deteriorated with blade angle slots. The computed stall margins, based on equivalent weight flow and total pressure ratio at stage peak efficiency, were (1) 17 percent for axial skewed slots, (2) 17 percent for blade angle slots, and (3) 17 percent for circumferential grooves. The stall margin for the solid casing configuration was 8 percent (ref. 1).

The axial skewed slots casing configuration offered the most gain in both rotor and stage overall performance. Peak efficiency values for the rotor and stage, with axial skewed slots, were 0.887 and 0.850, respectively. This represents an increase of three points in rotor peak efficiency and two points in stage peak efficiency over that of the solid casing configuration. Total pressure ratios for both rotor and stage, with axial skewed slots, at stage peak efficiency weight flow of 29.2 kilograms per second, were 1.59 and 1.56, respectively, as compared to the solid casing values of 1.53 and 1.495. Corresponding values of total temperature ratios for the stage, with axial skewed slots, at peak efficiency weight flow, were 1.16 as compared to the solid casing values of 1.15.

Radial Distributions

Radial distributions of performance parameters for the solid casing and axial skewed slots configurations, for both rotor and stator are discussed in the following sections. Only the axial skewed slot tip treatment is presented because this configuration represents the best improvement in performance over the solid casing configuration. The data from the other two tip treatment configurations are presented in the tables. Radial distribution of total loss coefficient for the inlet guide vane, for the solid casing configuration only, is also included. For each configuration, the performance parameters are presented for three weight flows; stall, peak efficiency, and maximum flow attainable. A solid line is faired through the peak efficiency weight flow data. Design values are shown by solid symbols.

Inlet guide vane. - The inlet guide vane total loss coefficients are presented only for the solid casing (fig. 12) which is representative of the losses for all configurations. As was noted in reference 1, substantial loss occurs in the end wall regions of the blade. The unusually high end wall losses may be due to wall boundary layer buildup caused by the relatively long inlet section ahead of the IGV. The five-stage compressor was designed with no IGV's. The IGV was designed at a later date and installed just prior to the testing of the five-stage compressor. As a result, the compressor design did not include a profile loss associated with the presence of IGV's.

Rotor and stator with solid casing. - The radial distribution of performance parameters for the rotor and stator with solid casing are presented in figures 13 and 14, respectively. As indicated by the radial distribution of meridional velocity ratio the rotor tip does not pass the required flow resulting in a redistribution of flow in the blade passage. Very high rotor tip losses resulted in low total pressure ratio and correspondingly low efficiency in the tip region. The large boundary layer coupled with locally high losses in the end wall region ahead of the rotor result in high incidence angles to the rotor tip. Deviation angles at the rotor tip are very high. The stator, as a result, was forced to operate at unusually high incidence angles (fig. 14).

Rotor and stator with axial skewed slot insert. - The radial distributions for the rotor, with axial skewed slots casing treatment, and the stator are presented in figures 15 and 16, respectively. The rotor with casing treatment exhibits a substantial improvement in performance in the tip region. The meridional velocity ratio shows no drop-off near the tip and deviation angles in the tip region approach the design value. As a result, the losses in the tip region are significantly reduced and total pressure ratio is substantially improved. As a result of this casing treatment, the rotor tip efficiency improved about 10 percentage points. With the improvement in the rotor tip performance, the stator performance (fig. 16) in the tip region also shows substantial improvement. The stator tip operated at design incidence angle at design flow. The blade loading in the tip region as indicated by diffusion factor nearly equaled design values; however, stator tip losses were extremely high indicating that the design losses were underestimated. The losses at other radial locations were also underestimated but to a lesser extent.

Variation of Blade-Element Performance with Incidence Angle

The variations of selected rotor and stator blade-element performance parameters with incidence angle are presented in figures 17 and 18, respectively. The variations are presented for the solid casing, blade angle slots, axial skewed slots, and circumferential groove configurations. Design values are shown by solid symbols.

Rotor. - All three rotor casing treatments allowed the rotor to operate over a much greater range of incidence angles across the entire blade span (fig. 17). Substantial improvement in rotor tip flow was obtained with all three casing treatment configurations as evidenced by very significant reductions in rotor tip losses and deviation angles, resulting in a large improvement in rotor tip total pressure ratio and efficiency. As a result of the rotor tip portion of the blade passing more flow with all three casing treatment configurations, a beneficial redistribution of flow was observed across the entire passage. Lower losses were observed across the entire passage, except near the damper, for all three casing treatments, resulting in higher pressure ratios with accompanying higher efficiencies.

Stator. - Although notable improvements in rotor performance across the entire passage were obtained with all three casing treatments, the only significant difference in stator performance occurred in the tip region (5 percent of blade span) wherein an improvement in flow was shown by the meridional velocity ratio (fig. 18). At design incidence angle, stator losses were underestimated across the entire blade except at 90 percent of span.

CONCLUDING REMARKS

The results of this casing treatment investigation substantiate the results obtained in a previous study (ref. 2) in that casing treatment has a pronounced effect on improving the performance of rotors and stages which are rotor tip critical. Both casing treatment studies were conducted on rotors which were tip critical; that is, blade elements in the tip region reach a critical operating condition and stall before the remaining elements. The results of this investigation showed significant improvements in both rotor and stage total pressure ratio, total temperature ratio, efficiency, and very large improvements in stage stall margin. The results from reference 1 showed the greatest improvements in performance were obtained through the use of short blade angle slots whereas, in the present investigation, the best improvements in performance were obtained with short axial skewed slots. One probable cause for this discrepancy is that the axial skewed slots in reference 2 extended beyond the leading and trailing edges of the rotor blades resulting in flow recirculation in the blade tip region. The slots in the present investigation did not extend beyond the blade edges.

SUMMARY OF RESULTS

An axial flow compressor inlet stage which was deficient in performance in the rotor tip region was tested at design speed with three different rotor casing treatment

configurations; circumferential grooves, blade angle slots, and axial skewed slots. Overall performance and blade-element data from radial surveys were obtained at several weight flows for each configuration. This investigation yielded the following principal results:

1. Significant improvements in stage flow range, and in rotor and stage overall pressure ratio and efficiency, along with very large gains in stage stall margin were realized with all three rotor casing treatment configurations.
2. The axial skewed slot configuration provided the greatest improvement in performance.

Lewis Research Center,
National Aeronautics and Space Administration,
Cleveland, Ohio, October 8, 1975,
505-04.

APPENDIX A

SYMBOLS

A_{an}	annulus area at rotor leading edge, m^2
A_f	frontal area at rotor leading edge, m^2
C_p	specific heat at constant pressure, $J/(kg)(K)$
D	diffusion factor
i_{mc}	mean incidence angle, angle between inlet air direction and line tangent to blade mean camber line at leading edge, deg
i_{ss}	suction-surface incidence angle, angle between inlet air direction and line tangent to blade suction surface at leading edge, deg
N	rotative speed, rpm
P	total pressure, N/cm^2
p	static pressure, N/cm^2
r	radius, cm
SM	stall margin
T	total temperature, K
U	wheel speed, m/sec
V	air velocity, m/sec
W	weight flow, kg/sec
Z	axial distance referenced from rotor blade hub leading edge, cm
α_c	cone angle, deg
α_s	slope of streamline, deg
β	air angle, angle between air velocity and axial direction, deg
β'_c	relative meridional air angle based on cone angle, $\arctan(\tan \beta'_m \cos \alpha_c / \cos \alpha_s)$, deg
γ	ratio of specific heats
δ	ratio of rotor inlet total pressure to standard pressure of $10.13 N/cm^2$
δ	deviation angle, angle between exit air direction and tangent to blade mean camber line at trailing edge, deg

θ	ratio of rotor inlet total temperature to standard temperature of 288.2 K
η	efficiency
κ_{mc}	angle between blade mean camber line and meridional plane, deg
κ_{ss}	angle between blade suction-surface camber line at leading edge and meridional plane, deg
σ	solidity, ratio of chord to spacing
$\bar{\omega}$	total loss coefficient
$\bar{\omega}_p$	profile loss coefficient
$\bar{\omega}_s$	shock loss coefficient

Subscripts:

ad	adiabatic (temperature rise)
id	ideal
LE	blade leading edge
m	meridional direction
mom	momentum rise
p	polytropic
TE	blade trailing edge
z	axial direction
θ	tangential direction
0	instrumentation plane upstream of inlet guide vanes
1	instrumentation plane upstream of rotor
2	instrumentation plane between rotor and stator
3	instrumentation plane downstream of stator

Superscript:

'	relative to blade
---	-------------------

APPENDIX B

EQUATIONS

Suction-surface incidence angle -

$$i_{ss} = (\beta'_c)_{LE} - \kappa_{ss} \quad (B1)$$

Mean incidence angle -

$$i_{mc} = (\beta'_c)_{LE} - (\kappa_{mc})_{LE} \quad (B2)$$

Deviation angle -

$$\delta^o = (\beta'_c)_{TE} - (\kappa_{mc})_{TE} \quad (B3)$$

Diffusion factor -

$$D = 1 - \frac{V'_{TE}}{V'_{LE}} + \left| \frac{(rV_\theta)_{TE} - (rV_\theta)_{LE}}{(r_{TE} + r_{LE})^\sigma (V'_{LE})} \right| \quad (B4)$$

Total loss coefficient -

$$\bar{\omega} = \frac{(P'_{id})_{TE} - P'_{TE}}{P'_{LE} - P_{LE}} \quad (B5)$$

Profile loss coefficient -

$$\bar{\omega}_p = \bar{\omega} - \bar{\omega}_s \quad (B6)$$

Total loss parameter -

$$\frac{\bar{\omega} \cos(\beta'_m)_{TE}}{2\sigma} \quad (B7)$$

Profile loss parameter -

$$\frac{\bar{\omega}_p \cos(\beta'_m)_{TE}}{2\sigma} \quad (B8)$$

Adiabatic (temperature rise) efficiency -

$$\eta_{ad} = \frac{\left(\frac{P_{TE}}{P_{LE}}\right)^{(\gamma-1)/\gamma} - 1}{\frac{T_{TE}}{T_{LE}} - 1} \quad (B9)$$

Momentum-rise efficiency -

$$\eta_{mom} = \frac{\left(\frac{P_{TE}}{P_{LE}}\right)^{(\gamma-1)/\gamma} - 1}{\frac{(UV_\theta)_{TE} - (UV_\theta)_{LE}}{T_{LE} C_p}} \quad (B10)$$

Equivalent weight flow -

$$\frac{W\sqrt{\theta}}{\delta} \quad (B11)$$

Equivalent rotative speed -

$$\frac{N}{\sqrt{\theta}} \quad (B12)$$

Weight flow per unit annulus area -

$$\frac{\left(\frac{W\sqrt{\theta}}{\delta}\right)}{A_{an}} \quad (B13)$$

Weight flow per unit frontal area -

$$\frac{\left(\frac{W\sqrt{\theta}}{\delta}\right)}{A_f} \quad (B14)$$

Head-rise coefficient -

$$\frac{C_p T_{LE}}{U_{tip}^2} \left[\left(\frac{P_{TE}}{P_{LE}}\right)^{(\gamma-1)/\gamma} - 1 \right] \quad (B15)$$

Flow coefficient -

$$\left(\frac{V_z}{U_{tip}}\right)_{LE} \quad (B16)$$

Stall margin -

$$SM = \left[\frac{\left(\frac{P_{TE}}{P_{LE}}\right)_{stall} \times \left(\frac{W\sqrt{\theta}}{\delta}\right)_{ref}}{\left(\frac{P_{TE}}{P_{LE}}\right)_{ref} \times \left(\frac{W\sqrt{\theta}}{\delta}\right)_{stall}} - 1 \right] \times 100 \quad (B17)$$

Polytropic efficiency -

$$\eta_p = \frac{\ln\left(\frac{P_{TE}}{P_{LE}}\right)^{(\gamma-1)/\gamma}}{\ln\left(\frac{T_{TE}}{T_{LE}}\right)} \quad (B18)$$

APPENDIX C

DEFINITIONS AND UNITS USED IN TABLES

ABS	absolute
AERO CHORD	aerodynamic chord, cm
AREA RATIO	ratio of actual flow area to critical area (where local Mach number is one)
BETAM	meridional air angle, deg
CONE ANGLE	angle between axial direction and conical surface representing blade element, deg
DELTA INC	difference between mean camber blade angle and suction-surface blade angle at leading edge, deg
DEV	deviation angle (defined by eq. (B3)), deg
D-FACT	diffusion factor (defined by eq. (B4))
EFF	adiabatic efficiency (defined by eq. (B9))
IN	inlet (leading edge of blade)
INCIDENCE	incidence angle (suction surface defined by eq. (B1) and mean defined by eq. (B2)), deg
KIC	angle between the blade mean camber line at the leading edge and the meridional plane, deg
KOC	angle between the blade mean camber line at the trailing edge and the meridional plane, deg
KTC	angle between the blade mean camber line at the transition point and the meridional plane, deg
LOSS COEFF	loss coefficient (total defined by eq. (B5) and profile defined by eq. (B6))
LOSS PARAM	loss parameter (total defined by eq. (B7) and profile defined by eq. (B8))
MERID	meridional
MERID VEL R	meridional velocity ratio
OUT	outlet (trailing edge of blade)
PERCENT SPAN	percent of blade span from tip at rotor outlet

PHISS	suction-surface camber ahead of assumed shock location, deg
PRESS	pressure, N/cm^2
PROF	profile
RADII	radius, cm
REL	relative to blade
RI	inlet radius (leading edge of blade), cm
RO	outlet radius (trailing edge of blade), cm
RP	radial position
RPM	equivalent rotative speed, rpm
SETTING ANGLE	angle between aerodynamic chord and meridional plane, deg
SOLIDITY	ratio of aerodynamic chord to blade spacing
SPEED	speed, m/sec
SS	suction surface
STREAMLINE SLOPE	slope of streamline, deg
TANG	tangential
TEMP	temperature, K
TI	thickness of blade at leading edge, cm
TM	thickness of blade at maximum thickness, cm
TO	thickness of blade at trailing edge, cm
TOT	total
TOTAL CAMBER	difference between inlet and outlet blade mean camber lines, deg
VEL	velocity, m/sec
WT FLOW	equivalent weight flow, kg/sec
X FACTOR	ratio of suction-surface camber ahead of assumed shock location of multiple-circular-arc blade section to that of double- circular-arc blade section
ZIC	axial distance to blade leading edge from inlet, cm
ZMC	axial distance to blade maximum thickness point from inlet, cm
ZOC	axial distance to blade trailing edge from inlet, cm
ZTC	axial distance to transition point from inlet, cm

REFERENCES

1. Urasek, Donald C. ; Steinke, Ronald J. ; and Lewis, George W. : Performance of Inlet Stage of Transonic Compressor. NASA TM X-3345, 1975.
2. Moore, Royce D. ; Kovich, George ; and Blade, Robert J. : Effect of Casing Treatment on Overall and Blade-Element Performance of a Compressor Rotor. NASA TN D-6538, 1971.
3. Ball, Calvin L. ; Janetzke, David C. ; and Reid, Lonnie : Performance of 1380-Foot-Per-Second-Tip-Speed Axial-Flow Compressor Rotor with Blade Tip Solidity of 1.5. NASA TM X-2379, 1972.
4. Crouse, James E. ; Janetzke, David C. ; and Schwirian, Richard E. : A Computer Program for Composing Compressor Blading from Simulated Circular-Arc Elements on Conical Surfaces. NASA TN D-5437, 1969.
5. Schwenk, Francis C. ; Lewis, George W. ; and Hartmann, Melvin J. : A Preliminary Analysis of the Magnitude of Shock Losses in Transonic Compressors. NACA RM E 57A30, 1957.

TABLE I. - TEST STAGE DESIGN

OVERALL PARAMETERS

ROTOR TOTAL PRESSURE RATIO.....	1.621
STAGE TOTAL PRESSURE RATIO	1.606
ROTOR TOTAL TEMPERATURE RATIO.....	1.168
STAGE TOTAL TEMPERATURE RATIO	1.168
ROTOR ADIABATIC EFFICIENCY.....	0.881
STAGE ADIABATIC EFFICIENCY	0.863
ROTOR POLYTROPIC EFFICIENCY.....	0.888
STAGE POLYTROPIC EFFICIENCY	0.871
ROTOR HEAD RISE COEFFICIENT.....	0.237
STAGE HEAD RISE COEFFICIENT	0.232
FLOW COEFFICIENT.....	0.464
WT FLOW PER UNIT FRONTAL AREA	147.469
WT FLOW PER UNIT ANNULUS AREA.....	197.021
WT FLOW	29.710
RPM.....	16042.300
TIP SPEED	425.426

TABLE II. - TEST ROTOR DESIGN BLADE-ELEMENT PARAMETERS

RP	RADII		ABS BETAM		REL BETAM		TOTAL TEMP		TOTAL PRESS	
	IN	OUT	IN	OUT	IN	OUT	IN	RATIO	IN	RATIO
TIP	25.324	25.222	0.	43.2	65.2	63.5	288.2	1.198	10.13	1.621
1	24.794	24.657	-0.	42.7	64.5	62.4	288.2	1.193	10.13	1.621
2	24.216	24.092	0.	42.2	63.8	61.4	288.2	1.187	10.13	1.621
3	23.041	22.962	0.	41.3	62.4	59.2	288.2	1.177	10.13	1.621
4	21.841	21.831	0.	41.0	60.9	56.7	288.2	1.169	10.13	1.621
5	20.866	20.927	0.	41.3	59.8	54.3	288.2	1.165	10.13	1.621
6	19.878	20.023	0.	41.9	58.7	51.7	288.2	1.162	10.13	1.621
7	19.378	19.571	0.	42.3	58.1	50.1	288.2	1.161	10.13	1.621
8	16.811	17.310	0.	44.8	55.1	40.3	288.2	1.158	10.13	1.621
9	15.470	16.180	0.	46.6	53.3	33.2	288.2	1.157	10.13	1.621
10	14.079	15.049	0.	48.6	51.4	24.2	288.2	1.158	10.13	1.621
11	13.361	14.484	0.	49.6	50.3	18.9	288.2	1.158	10.13	1.621
HUB	12.700	13.919	-0.	50.5	49.2	13.2	288.2	1.159	10.13	1.621

RP	ABS VEL		REL VEL		MERID VEL		TANG VEL		WHEEL SPEED	
	IN	OUT	IN	OUT	IN	OUT	IN	OUT	IN	OUT
TIP	196.6	197.5	468.6	322.3	196.6	143.9	0.	135.3	425.4	423.7
1	198.4	198.6	461.4	315.2	198.4	145.9	-0.	134.8	416.5	414.2
2	200.1	199.6	453.4	308.3	200.1	147.8	0.	134.2	406.8	404.7
3	202.6	201.1	436.9	294.6	202.6	151.1	0.	132.8	387.1	385.7
4	203.8	203.3	419.7	279.4	203.8	153.5	0.	133.3	366.9	366.8
5	203.8	206.0	405.5	265.3	203.8	154.7	0.	136.0	350.5	351.6
6	203.0	209.1	390.8	250.7	203.0	155.5	0.	139.8	333.9	336.4
7	202.4	211.0	383.4	243.3	202.4	156.0	0.	142.1	325.5	328.8
8	197.3	222.7	344.5	207.1	197.3	158.0	0.	156.9	282.4	290.8
9	193.5	231.0	324.0	189.9	193.5	158.8	0.	167.7	259.9	271.8
10	189.0	241.5	302.8	175.1	189.0	159.7	0.	181.2	236.5	252.8
11	186.5	247.6	291.8	169.6	186.5	160.5	0.	188.5	224.5	243.3
HUB	184.2	254.0	281.9	165.8	184.2	161.5	-0.	196.0	213.4	233.8

RP	ABS MACH NO		REL MACH NO		MERID MACH NO		STREAMLINE SLOPE		MERID PEAK SS	
	IN	OUT	IN	OUT	IN	OUT	IN	OUT	VEL R	MACH NO
TIP	0.598	0.546	1.426	0.891	0.598	0.398	-3.94	-4.94	0.732	1.524
1	0.604	0.550	1.405	0.874	0.604	0.404	-3.63	-4.14	0.735	1.514
2	0.610	0.555	1.381	0.857	0.610	0.411	-3.19	-3.31	0.738	1.504
3	0.618	0.562	1.332	0.823	0.618	0.422	-1.87	-1.56	0.746	1.483
4	0.622	0.570	1.280	0.784	0.622	0.437	-0.06	0.36	0.753	1.463
5	0.622	0.579	1.237	0.746	0.622	0.435	1.63	1.98	0.759	1.450
6	0.619	0.590	1.192	0.707	0.619	0.439	3.47	3.68	0.766	1.439
7	0.617	0.595	1.169	0.687	0.617	0.440	4.45	4.56	0.770	1.434
8	0.601	0.632	1.048	0.588	0.601	0.448	9.90	9.38	0.800	1.418
9	0.588	0.658	0.985	0.541	0.588	0.452	13.05	12.15	0.820	1.410
10	0.573	0.690	0.919	0.500	0.573	0.457	16.51	15.28	0.845	1.346
11	0.565	0.709	0.885	0.486	0.565	0.460	18.39	17.02	0.861	1.298
HUB	0.558	0.729	0.854	0.476	0.558	0.464	20.14	18.81	0.876	1.261

RP	PERCENT SPAN	INCIDENCE		DEV	D-FACT	EFF	LOSS COEFF		LOSS PARAM	
		MEAN	SS				TOT	PROF	TOT	PROF
TIP	0.	2.7	0.0	4.7	0.416	0.747	0.198	0.108	0.032	0.017
1	5.00	2.9	-0.0	4.5	0.419	0.767	0.181	0.097	0.029	0.016
2	10.00	3.2	0.0	4.3	0.421	0.789	0.164	0.086	0.027	0.014
3	20.00	3.7	0.0	4.0	0.425	0.836	0.127	0.060	0.021	0.010
4	30.00	4.3	0.0	3.7	0.433	0.877	0.097	0.041	0.017	0.007
5	38.00	4.7	0.0	3.6	0.445	0.896	0.084	0.036	0.014	0.005
6	46.00	5.1	0.0	3.6	0.460	0.911	0.074	0.034	0.013	0.006
7	50.00	5.3	0.0	3.7	0.468	0.917	0.070	0.034	0.012	0.006
8	70.00	6.1	0.0	4.7	0.510	0.939	0.059	0.037	0.011	0.007
9	80.00	6.4	0.0	5.6	0.531	0.940	0.063	0.048	0.012	0.009
10	90.00	6.6	0.0	6.7	0.546	0.936	0.076	0.070	0.014	0.013
11	95.00	6.6	0.0	7.2	0.546	0.934	0.082	0.080	0.015	0.014
HUB	100.00	6.8	0.1	7.8	0.543	0.933	0.088	0.087	0.015	0.015

TABLE III. - TEST STATOR DESIGN BLADE-ELEMENT PARAMETERS

RP	RADII		ABS BETAM		REL BETAM		TOTAL TEMP		TOTAL PRESS	
	IN	OUT	IN	OUT	IN	OUT	IN	RATIO	IN	RATIO
TIP	24.968	25.121	39.6	0.	39.6	0.	345.2	1.003	16.42	0.985
1	24.447	24.358	39.2	-0.	39.2	-0.	343.7	1.000	16.42	0.990
2	23.937	23.897	38.8	0.	38.8	0.	342.2	1.000	16.42	0.993
3	22.913	22.970	38.0	0.	38.0	0.	339.1	1.000	16.42	0.994
4	21.886	22.038	37.7	0.	37.7	0.	336.8	1.000	16.42	0.994
5	21.063	21.290	38.0	0.	38.0	0.	335.7	1.000	16.42	0.994
6	20.240	20.544	38.6	0.	38.6	0.	334.9	1.000	16.42	0.994
7	19.827	20.172	39.0	0.	39.0	0.	334.6	1.000	16.42	0.993
8	17.767	18.326	41.3	0.	41.3	0.	333.6	1.000	16.42	0.991
9	16.739	17.412	43.0	0.	43.0	0.	333.5	1.000	16.42	0.988
10	15.715	16.499	44.9	0.	44.9	0.	333.7	1.000	16.42	0.980
11	15.207	16.040	45.8	0.	45.8	0.	333.8	1.000	16.42	0.972
HUB	14.834	15.494	46.4	-0.	46.4	-0.	333.8	1.000	16.42	0.962

RP	ABS VEL		REL VEL		MERID VEL		TANG VEL		WHEEL SPEED	
	IN	OUT	IN	OUT	IN	OUT	IN	OUT	IN	OUT
TIP	214.3	174.3	214.3	174.3	165.0	174.3	136.7	0.	0.	0.
1	215.0	176.1	215.0	176.1	166.5	176.1	135.9	-0.	0.	0.
2	215.5	177.0	215.5	177.0	168.0	177.0	135.0	0.	0.	0.
3	216.3	177.8	216.3	177.8	170.6	177.8	133.1	0.	0.	0.
4	217.6	177.8	217.6	177.8	172.2	177.8	132.9	0.	0.	0.
5	219.4	177.7	219.4	177.7	172.8	177.7	135.1	0.	0.	0.
6	221.5	177.3	221.5	177.3	173.1	177.3	138.3	0.	0.	0.
7	222.9	177.0	222.9	177.0	173.2	177.0	140.2	0.	0.	0.
8	231.5	174.3	231.5	174.3	173.8	174.3	152.9	0.	0.	0.
9	237.8	170.9	237.8	170.9	174.0	170.9	162.1	0.	0.	0.
10	245.9	165.0	245.9	165.0	174.3	165.0	173.5	0.	0.	0.
11	250.5	161.0	250.5	161.0	174.7	161.0	179.5	0.	0.	0.
HUB	254.1	155.8	254.1	155.8	175.1	155.8	184.1	-0.	0.	0.

RP	ABS MACH NO		REL MACH NO		MERID MACH NO		STREAMLINE SLOPE		MERID PEAK SS	
	IN	OUT	IN	OUT	IN	OUT	IN	OUT	VEL R	MACH NO
TIP	0.595	0.478	0.595	0.478	0.459	0.478	-3.54	-2.24	1.056	0.962
1	0.599	0.485	0.599	0.485	0.464	0.485	-2.48	-0.99	1.057	0.955
2	0.602	0.489	0.602	0.489	0.469	0.489	-1.49	-0.25	1.054	0.949
3	0.607	0.493	0.607	0.493	0.479	0.493	0.35	1.18	1.042	0.935
4	0.613	0.495	0.613	0.495	0.486	0.495	2.03	2.56	1.033	0.930
5	0.620	0.496	0.620	0.496	0.488	0.496	3.33	3.68	1.028	0.935
6	0.627	0.495	0.627	0.495	0.490	0.495	4.64	4.84	1.024	0.947
7	0.632	0.495	0.632	0.495	0.491	0.495	5.32	5.44	1.022	0.953
8	0.659	0.487	0.659	0.487	0.495	0.487	8.93	8.61	1.003	0.999
9	0.679	0.478	0.679	0.478	0.497	0.478	10.94	10.35	0.983	1.034
10	0.704	0.460	0.704	0.460	0.499	0.460	13.07	12.21	0.947	1.079
11	0.719	0.448	0.719	0.448	0.501	0.448	14.17	13.20	0.921	1.103
HUB	0.730	0.433	0.730	0.433	0.503	0.433	14.98	14.39	0.890	1.131

RP	PERCENT SPAN	INCIDENCE		DEV	D-FACT	EFF	LOSS COEFF		LOSS PARAM	
		MEAN	SS				TOT	PROF	TOT	PROF
TIP	0.	4.0	-3.0	8.7	0.401	0.	0.115	0.115	0.039	0.039
1	5.00	3.9	-2.9	8.4	0.389	0.	0.045	0.045	0.015	0.015
2	10.00	3.7	-2.8	8.2	0.381	0.	0.034	0.034	0.011	0.011
3	20.00	3.7	-2.5	7.8	0.368	0.	0.029	0.029	0.009	0.009
4	30.00	3.5	-2.3	7.6	0.362	0.	0.026	0.026	0.008	0.008
5	38.00	3.3	-2.1	7.5	0.364	0.	0.027	0.027	0.008	0.008
6	46.00	3.2	-1.9	7.5	0.369	0.	0.028	0.028	0.008	0.008
7	50.00	3.1	-1.9	7.5	0.375	0.	0.028	0.028	0.008	0.008
8	70.00	2.8	-1.5	7.7	0.403	0.	0.034	0.034	0.008	0.008
9	80.00	2.6	-1.3	7.8	0.432	0.	0.045	0.045	0.010	0.010
10	90.00	2.4	-1.1	8.0	0.475	0.	0.071	0.071	0.015	0.015
11	95.00	2.4	-1.0	8.0	0.500	0.	0.096	0.096	0.020	0.020
HUB	100.00	2.7	-0.6	8.1	0.529	0.	0.130	0.130	0.026	0.026

TABLE IV. - TEST ROTOR BLADE GEOMETRY

RP	PERCENT RADII		BLADE ANGLES			DELTA INC	CONE ANGLE
	SPAN	RI RO	KIC	KTC	KOC		
TIP	0.	25.324 25.222	62.51	63.11	58.81	2.68	-3.238
1	5.	24.794 24.657	61.59	62.04	57.92	2.93	-4.225
2	10.	24.216 24.092	60.60	60.87	57.03	3.20	-3.688
3	20.	23.041 22.962	58.61	58.47	55.18	3.75	-2.213
4	30.	21.841 21.831	56.67	55.94	52.98	4.27	-0.268
5	38.	20.866 20.927	55.14	53.75	50.75	4.69	1.522
6	46.	19.878 20.023	53.63	51.48	48.06	5.07	3.444
7	50.	19.378 19.571	52.87	50.29	46.46	5.26	4.458
8	70.	16.811 17.310	48.96	44.21	35.52	6.08	10.070
9	80.	15.470 16.180	46.91	40.93	27.52	6.39	13.261
10	90.	14.079 15.049	44.75	37.49	17.34	6.59	16.722
11	95.	13.361 14.484	43.60	35.80	11.47	6.65	18.571
HUB	100.	12.700 13.919	42.52	34.26	5.34	6.68	19.462

RP	BLADE THICKNESSES			AXIAL DIMENSIONS			
	TI	TM	TO	ZIC	ZMC	ZTC	ZOC
TIP	0.025	0.115	0.025	0.808	1.689	1.936	2.604
1	0.028	0.126	0.028	0.778	1.688	1.910	2.636
2	0.030	0.138	0.030	0.746	1.687	1.879	2.667
3	0.035	0.161	0.035	0.681	1.684	1.809	2.730
4	0.041	0.184	0.041	0.615	1.680	1.726	2.795
5	0.044	0.202	0.044	0.561	1.677	1.650	2.852
6	0.048	0.218	0.048	0.505	1.672	1.565	2.913
7	0.050	0.227	0.050	0.476	1.670	1.518	2.946
8	0.059	0.265	0.059	0.320	1.650	1.244	3.130
9	0.062	0.282	0.062	0.226	1.635	1.075	3.237
10	0.066	0.298	0.066	0.117	1.616	0.879	3.347
11	0.068	0.305	0.068	0.057	1.606	0.772	3.399
HUB	0.069	0.312	0.069	0.000	1.596	0.672	3.450

RP	AERO SETTING TOTAL			X			AREA RATIO
	CHORD	ANGLE	CAMBER	SOLIDITY	FACTOR	PHISS	
TIP	3.875	62.15	3.70	1.391	0.592	2.83	1.045
1	3.884	61.13	3.67	1.425	0.641	3.19	1.040
2	3.884	60.03	3.58	1.459	0.693	3.58	1.034
3	3.882	57.79	3.43	1.531	0.788	4.35	1.024
4	3.881	55.42	3.69	1.613	0.868	5.19	1.014
5	3.882	53.32	4.39	1.685	0.921	5.96	1.007
6	3.884	51.04	5.57	1.766	0.961	6.76	1.004
7	3.886	49.78	6.41	1.810	0.977	7.17	1.003
8	3.914	42.24	13.44	2.081	1.002	9.03	0.997
9	3.947	37.23	19.39	2.263	1.000	9.90	0.999
10	4.003	31.06	27.41	2.494	1.000	10.69	1.005
11	4.044	27.55	32.13	2.635	1.000	10.94	1.009
HUB	4.073	23.95	37.18	2.776	1.000	11.13	1.013

TABLE V. - TEST STATOR BLADE GEOMETRY

RP	PERCENT RADII			BLADE ANGLES			DELTA INC	CONE ANGLE
	SPAN	RI	RO	KIC	KTC	KOC		
TIP	0.	24.968	25.121	35.67	21.55	-8.65	7.04	2.507
1	5.	24.447	24.358	35.39	21.72	-8.37	6.76	-1.470
2	10.	23.937	23.897	35.05	21.85	-8.18	6.53	-0.657
3	20.	22.913	22.970	34.29	22.08	-7.79	6.21	0.944
4	30.	21.886	22.038	34.18	22.54	-7.56	5.78	2.481
5	38.	21.063	21.290	34.68	23.15	-7.51	5.45	3.716
6	46.	20.240	20.544	35.41	23.90	-7.52	5.13	4.985
7	50.	19.827	20.172	35.86	24.32	-7.53	4.97	5.642
8	70.	17.767	18.326	38.55	26.75	-7.66	4.23	9.146
9	80.	16.739	17.412	40.37	28.31	-7.79	3.89	11.009
10	90.	15.715	16.499	42.46	30.08	-7.96	3.57	12.824
11	95.	15.207	16.040	43.47	30.99	-8.02	3.42	13.652
HUB	100.	14.834	15.494	44.21	31.67	-8.09	3.32	10.909

RP	BLADE THICKNESSES			AXIAL DIMENSIONS			
	TI	TM	TO	ZIC	ZMC	ZTC	ZOC
TIP	0.065	0.297	0.067	6.042	7.700	7.068	9.523
1	0.064	0.286	0.064	6.040	7.701	7.045	9.524
2	0.062	0.276	0.062	6.037	7.701	7.021	9.524
3	0.057	0.261	0.057	6.032	7.703	6.969	9.526
4	0.054	0.243	0.054	6.031	7.703	6.932	9.527
5	0.051	0.230	0.051	6.034	7.703	6.912	9.529
6	0.048	0.217	0.048	6.039	7.702	6.896	9.531
7	0.047	0.211	0.047	6.042	7.702	6.889	9.531
8	0.040	0.182	0.040	6.061	7.699	6.855	9.534
9	0.037	0.169	0.037	6.075	7.697	6.841	9.535
10	0.035	0.156	0.035	6.093	7.695	6.828	9.535
11	0.033	0.151	0.033	6.102	7.693	6.820	9.535
HUB	0.032	0.147	0.032	6.109	7.693	6.814	9.535

RP	AERO CHORD	SETTING ANGLE	TOTAL CAMBER	X SOLIDITY	FACTOR	PHISS	AREA RATIO
TIP	3.650	13.53	44.32	1.484	1.000	18.33	1.139
1	3.648	13.51	43.75	1.523	1.000	17.64	1.149
2	3.647	13.44	43.24	1.553	1.000	16.95	1.157
3	3.647	13.25	42.07	1.619	1.000	15.62	1.169
4	3.650	13.31	41.74	1.693	1.000	14.69	1.180
5	3.654	13.58	42.19	1.758	1.000	14.34	1.187
6	3.660	13.95	42.93	1.828	1.000	14.12	1.193
7	3.663	14.17	43.39	1.866	1.000	14.04	1.195
8	3.690	15.44	46.21	2.083	1.000	13.81	1.207
9	3.709	16.29	48.16	2.213	1.000	13.87	1.216
10	3.732	17.25	50.42	2.360	1.000	13.99	1.227
11	3.743	17.72	51.49	2.440	1.000	14.00	1.231
HUB	3.702	18.06	52.30	2.487	1.000	14.00	1.234

TABLE VI. - OVERALL PERFORMANCE WITH VARIOUS CASING TREATMENTS

(100 PERCENT OF DESIGN SPEED)

(a) With axial skewed slots

Parameter	Reading number				
	724	736	749	760	771
ROTOR TOTAL PRESSURE RATIO	1.425	1.544	1.645	1.667	1.684
STAGE TOTAL PRESSURE RATIO	1.386	1.511	1.616	1.640	1.666
ROTOR TOTAL TEMPERATURE RATIO	1.125	1.149	1.174	1.182	1.190
STAGE TOTAL TEMPERATURE RATIO	1.122	1.148	1.175	1.183	1.195
ROTOR ADIABATIC EFFICIENCY	0.852	0.887	0.878	0.864	0.846
STAGE ADIABATIC EFFICIENCY	0.801	0.845	0.842	0.828	0.806
ROTOR POLYTROPIC EFFICIENCY	0.859	0.894	0.886	0.874	0.857
STAGE POLYTROPIC EFFICIENCY	0.810	0.854	0.852	0.839	0.819
ROTOR HEAD RISE COEFFICIENT	0.168	0.213	0.245	0.251	0.257
STAGE HEAD RISE COEFFICIENT	0.154	0.201	0.235	0.243	0.251
FLOW COEFFICIENT	0.441	0.432	0.408	0.396	0.375
EQUIVALENT VALUES BASED ON STAGE INLET					
WEIGHT FLOW	30.18	29.60	28.50	27.88	26.75
WEIGHT FLOW PER UNIT ANNULUS AREA	200.13	196.26	189.01	184.88	177.38
WEIGHT FLOW PER UNIT FRONTAL AREA	149.80	146.90	141.47	138.38	132.77
WHEEL SPEED, RPM	16141.9	15995.8	16034.7	16036.4	16030.1
TIP SPEED	428.1	424.1	425.2	425.3	425.1
PERCENT OF DESIGN SPEED	100.6	99.7	100.0	100.0	99.9
CUMULATIVE VALUES					
COMPRESSOR TOTAL PRESSURE RATIO	1.365	1.492	1.600	1.626	1.654
COMPRESSOR TOTAL TEMPERATURE RATIO	1.126	1.152	1.178	1.187	1.198
COMPRESSOR ADIABATIC EFFICIENCY	0.741	0.800	0.808	0.798	0.782
COMPRESSOR POLYTROPIC EFFICIENCY	0.752	0.811	0.821	0.811	0.797

TABLE VI. - Continued.

(b) With circumferential grooves

Parameter	Reading number				
	785	796	808	819	830
ROTOR TOTAL PRESSURE RATIO	1.632	1.518	1.590	1.631	1.644
STAGE TOTAL PRESSURE RATIO	1.600	1.473	1.551	1.591	1.607
ROTOR TOTAL TEMPERATURE RATIO	1.182	1.149	1.164	1.173	1.179
STAGE TOTAL TEMPERATURE RATIO	1.183	1.142	1.159	1.171	1.179
ROTOR ADIABATIC EFFICIENCY	0.824	0.851	0.865	0.866	0.854
STAGE ADIABATIC EFFICIENCY	0.783	0.822	0.838	0.832	0.808
ROTOR POLYTROPIC EFFICIENCY	0.836	0.859	0.873	0.875	0.864
STAGE POLYTROPIC EFFICIENCY	0.797	0.832	0.848	0.842	0.821
ROTOR HEAD RISE COEFFICIENT	0.242	0.203	0.227	0.240	0.244
STAGE HEAD RISE COEFFICIENT	0.232	0.187	0.214	0.227	0.232
FLOW COEFFICIENT	0.354	0.431	0.419	0.403	0.381
EQUIVALENT VALUES BASED ON STAGE INLET					
WEIGHT FLOW	25.53	29.61	29.02	28.25	27.10
WEIGHT FLOW PER UNIT ANNULUS AREA	169.28	196.37	192.44	187.34	179.71
WEIGHT FLOW PER UNIT FRONTAL AREA	126.71	146.98	144.04	140.22	134.51
WHEEL SPEED, RPM	15979.2	16028.5	16026.7	16051.9	16044.4
TIP SPEED	423.8	425.1	425.0	425.7	425.5
PERCENT OF DESIGN SPEED	99.6	99.9	99.9	100.1	100.0
CUMULATIVE VALUES					
COMPRESSOR TOTAL PRESSURE RATIO	1.592	1.463	1.541	1.582	1.598
COMPRESSOR TOTAL TEMPERATURE RATIO	1.185	1.146	1.162	1.174	1.182
COMPRESSOR ADIABATIC EFFICIENCY	0.766	0.789	0.810	0.807	0.787
COMPRESSOR POLYTROPIC EFFICIENCY	0.781	0.800	0.821	0.819	0.801

TABLE VI. - Continued.

(c) With solid casing

Parameter	Reading number				
	845	856	867	884	895
ROTOR TOTAL PRESSURE RATIO	1.591	1.581	1.553	1.517	1.445
STAGE TOTAL PRESSURE RATIO	1.558	1.548	1.518	1.478	1.392
ROTOR TOTAL TEMPERATURE RATIO	1.166	1.163	1.157	1.149	1.135
STAGE TOTAL TEMPERATURE RATIO	1.166	1.161	1.153	1.143	1.125
ROTOR ADIABATIC EFFICIENCY	0.853	0.855	0.855	0.847	0.822
STAGE ADIABATIC EFFICIENCY	0.813	0.823	0.830	0.827	0.790
ROTOR POLYTROPIC EFFICIENCY	0.863	0.864	0.864	0.856	0.831
STAGE POLYTROPIC EFFICIENCY	0.825	0.834	0.840	0.836	0.800
ROTOR HEAD RISE COEFFICIENT	0.228	0.224	0.216	0.201	0.176
STAGE HEAD RISE COEFFICIENT	0.217	0.213	0.204	0.188	0.157
FLOW COEFFICIENT	0.395	0.406	0.416	0.426	0.434
EQUIVALENT VALUES BASED ON STAGE INLET					
WEIGHT FLOW	27.78	28.38	28.81	29.40	29.82
WEIGHT FLOW PER UNIT ANNULUS AREA	184.23	188.18	191.08	194.99	197.76
WEIGHT FLOW PER UNIT FRONTAL AREA	137.90	140.85	143.02	145.95	148.03
WHEEL SPEED, RPM	16008.6	16037.4	15986.6	16072.0	16091.2
TIP SPEED	424.5	425.3	423.9	426.2	426.7
PERCENT OF DESIGN SPEED	99.8	100.0	99.7	100.2	100.3
CUMULATIVE VALUES					
COMPRESSOR TOTAL PRESSURE RATIO	1.549	1.538	1.508	1.467	1.381
COMPRESSOR TOTAL TEMPERATURE RATIO	1.169	1.165	1.156	1.146	1.129
COMPRESSOR ADIABATIC EFFICIENCY	0.788	0.795	0.799	0.794	0.752
COMPRESSOR POLYTROPIC EFFICIENCY	0.801	0.808	0.810	0.804	0.763

TABLE VI. - Concluded.

(d) With blade angle slots

Parameter	Reading number				
	916	927	938	950	963
ROTOR TOTAL PRESSURE RATIO	1.685	1.654	1.612	1.563	1.481
STAGE TOTAL PRESSURE RATIO	1.650	1.610	1.568	1.518	1.429
ROTOR TOTAL TEMPERATURE RATIO	1.192	1.180	1.167	1.156	1.139
STAGE TOTAL TEMPERATURE RATIO	1.194	1.181	1.167	1.154	1.135
ROTOR ADIABATIC EFFICIENCY	0.836	0.860	0.875	0.873	0.858
STAGE ADIABATIC EFFICIENCY	0.791	0.806	0.820	0.822	0.799
ROTOR POLYTROPIC EFFICIENCY	0.847	0.870	0.883	0.881	0.865
STAGE POLYTROPIC EFFICIENCY	0.806	0.819	0.831	0.832	0.809
ROTOR HEAD RISE COEFFICIENT	0.255	0.248	0.235	0.219	0.191
STAGE HEAD RISE COEFFICIENT	0.244	0.234	0.220	0.204	0.173
FLOW COEFFICIENT	0.370	0.392	0.409	0.424	0.436
EQUIVALENT VALUES BASED ON STAGE INLET					
WEIGHT FLOW	26.57	27.62	28.49	29.20	29.78
WEIGHT FLOW PER UNIT ANNULUS AREA	176.19	183.16	188.91	193.63	197.45
WEIGHT FLOW PER UNIT FRONTAL AREA	131.88	137.10	141.40	144.93	147.79
WHEEL SPEED, RPM	16096.3	16009.3	16003.2	15990.5	16004.8
TIP SPEED	426.9	424.6	424.4	424.1	424.4
PERCENT OF DESIGN SPEED	100.3	99.8	99.8	99.7	99.8
CUMULATIVE VALUES					
COMPRESSOR TOTAL PRESSURE RATIO	1.641	1.601	1.558	1.507	1.418
COMPRESSOR TOTAL TEMPERATURE RATIO	1.197	1.184	1.171	1.157	1.138
COMPRESSOR ADIABATIC EFFICIENCY	0.773	0.782	0.791	0.790	0.761
COMPRESSOR POLYTROPIC EFFICIENCY	0.788	0.796	0.804	0.802	0.773

TABLE VII. - INLET GUIDE VANE BLADE-ELEMENT DATA

(a) Reading 724

RP	RADI I		ABS BETAM		REL BETAM		TOTAL TEMP		TOTAL PRESS	
	IN	OUT	IN	OUT	IN	OUT	IN	RATIO	IN	RATIO
1	25.072	24.971	-1.1	-0.6	-1.1	-0.6	289.3	1.004	10.02	0.990
2	24.412	24.354	-0.4	-0.8	-0.4	-0.8	288.8	1.004	10.14	0.993
3	23.058	23.096	-0.3	-0.5	-0.3	-0.5	288.3	1.004	10.14	0.994
4	21.659	21.806	0.9	-0.5	0.9	-0.5	288.1	1.004	10.14	0.994
5	20.508	20.752	0.6	-0.2	0.6	-0.2	288.0	1.004	10.14	0.972
6	19.334	19.682	1.1	-1.4	1.1	-1.4	287.9	1.004	10.14	0.991
7	18.738	19.139	0.8	-0.2	0.8	-0.2	287.9	1.003	10.14	0.990
8	15.624	16.350	3.9	-1.5	3.9	-1.5	287.7	1.002	10.14	0.976
9	13.960	14.889	2.8	-1.1	2.8	-1.1	287.7	1.002	10.14	0.977
10	12.192	13.365	3.7	-0.7	3.7	-0.7	287.9	1.001	10.14	0.975
11	11.255	12.573	2.8	2.0	2.8	2.0	288.7	1.000	10.14	0.975

RP	ABS VEL		REL VEL		MERID VEL		TANG VEL		WHEEL SPEED	
	IN	OUT	IN	OUT	IN	OUT	IN	OUT	IN	OUT
1	155.5	181.3	155.5	181.3	155.4	181.3	-3.0	-1.8	0.	0.
2	162.0	187.5	162.0	187.5	162.0	187.5	-1.0	-2.6	0.	0.
3	165.2	192.0	165.2	192.0	165.2	192.0	-0.9	-1.7	0.	0.
4	164.3	188.5	164.3	188.5	164.2	188.5	2.6	-1.7	0.	0.
5	164.0	183.3	164.0	183.3	164.0	183.3	1.7	-0.8	0.	0.
6	163.2	185.9	163.2	185.9	163.2	185.9	3.2	-4.5	0.	0.
7	162.7	186.0	162.7	186.0	162.7	186.0	2.2	-0.7	0.	0.
8	159.2	177.2	159.2	177.2	158.8	177.1	10.8	-4.6	0.	0.
9	155.9	173.6	155.9	173.6	155.8	173.6	7.6	-3.3	0.	0.
10	152.1	168.4	152.1	168.4	151.7	168.4	9.9	-2.1	0.	0.
11	149.7	166.4	149.7	166.4	149.5	166.3	7.3	5.7	0.	0.

RP	ABS MACH NO		REL MACH NO		MERID MACH NO		MERID PEAK SS	
	IN	OUT	IN	OUT	IN	OUT	VEL R	MACH NO
1	0.466	0.546	0.466	0.546	0.466	0.546	1.167	0.466
2	0.487	0.567	0.487	0.567	0.487	0.567	1.158	0.487
3	0.497	0.581	0.497	0.581	0.497	0.581	1.162	0.497
4	0.494	0.571	0.494	0.571	0.494	0.571	1.148	0.494
5	0.494	0.554	0.494	0.554	0.494	0.554	1.118	0.494
6	0.491	0.562	0.491	0.562	0.491	0.562	1.139	0.491
7	0.490	0.563	0.490	0.563	0.490	0.563	1.143	0.490
8	0.479	0.535	0.479	0.535	0.478	0.535	1.115	0.479
9	0.469	0.524	0.469	0.524	0.468	0.524	1.114	0.469
10	0.456	0.507	0.456	0.507	0.455	0.507	1.110	0.456
11	0.448	0.500	0.448	0.500	0.448	0.500	1.112	0.448

RP	PERCENT	INCIDENCE		DEV	D-FACT	EFF	LOSS COEFF		LOSS PARAM	
	SPAN	MEAN	SS				TOT	PROF	TOT	PROF
1	5.00	-1.1	-13.1	-0.6	-0.162	0.	0.073	0.073	0.037	0.037
2	10.00	-0.4	-12.4	-0.8	-0.153	0.	0.046	0.046	0.022	0.022
3	20.00	-0.3	-12.3	-0.5	-0.160	0.	0.039	0.039	0.018	0.018
4	30.00	0.9	-11.1	-0.5	-0.136	0.	0.036	0.036	0.016	0.016
5	38.00	0.6	-11.4	-0.2	-0.112	0.	0.180	0.180	0.075	0.075
6	46.00	1.1	-10.9	-1.4	-0.120	0.	0.061	0.061	0.024	0.024
7	50.00	0.8	-11.2	-0.2	-0.136	0.	0.063	0.063	0.024	0.024
8	70.00	3.9	-8.1	-1.5	-0.082	0.	0.165	0.165	0.053	0.053
9	80.00	2.8	-9.2	-1.1	-0.093	0.	0.165	0.165	0.048	0.048
10	90.00	3.7	-8.3	-0.7	-0.088	0.	0.189	0.189	0.048	0.048
11	95.00	2.8	-9.2	2.0	-0.110	0.	0.193	0.193	0.045	0.045

TABLE VII. - Continued.

(b) Reading 736

RP	RADI I		ABS BETAM		REL BETAM		TOTAL TEMP		TOTAL PRESS	
	IN	OUT	IN	OUT	IN	OUT	IN	RATIO	IN	RATIO
1	25.072	24.971	-0.9	-0.7	-0.9	-0.7	289.1	1.003	10.02	0.990
2	24.412	24.354	0.2	-0.7	0.2	-0.7	288.8	1.003	10.14	0.993
3	23.058	23.096	0.	-0.4	0.	-0.4	288.4	1.003	10.14	0.994
4	21.659	21.806	0.9	-0.3	0.9	-0.3	288.0	1.004	10.14	0.994
5	20.508	20.752	1.2	-0.2	1.2	-0.2	288.0	1.004	10.15	0.993
6	19.334	19.682	1.5	-0.0	1.5	-0.0	287.9	1.004	10.14	0.993
7	18.738	19.139	2.1	-0.1	2.1	-0.1	287.8	1.004	10.14	0.991
8	15.624	16.350	3.5	-1.5	3.5	-1.5	287.7	1.002	10.14	0.979
9	13.960	14.889	2.9	-1.2	2.9	-1.2	287.7	1.002	10.14	0.978
10	12.192	13.365	3.8	-0.8	3.8	-0.8	287.9	1.001	10.14	0.977
11	11.255	12.573	3.3	2.0	3.3	2.0	288.7	1.000	10.14	0.978

RP	ABS VEL		REL VEL		MERID VEL		TANG VEL		WHEEL SPEED	
	IN	OUT	IN	OUT	IN	OUT	IN	OUT	IN	OUT
1	151.7	173.8	151.7	173.8	151.7	173.8	-2.4	-2.1	0.	0.
2	158.6	180.4	158.6	180.4	158.6	180.3	0.6	-2.1	0.	0.
3	161.8	184.1	161.8	184.1	161.8	184.1	0.	-1.3	0.	0.
4	160.9	183.8	160.9	183.8	160.9	183.8	2.5	-0.9	0.	0.
5	160.7	183.5	160.7	183.5	160.7	183.5	3.4	-0.8	0.	0.
6	159.8	182.3	159.8	182.3	159.8	182.3	4.3	-0.0	0.	0.
7	159.3	181.2	159.3	181.2	159.2	181.2	5.9	-0.2	0.	0.
8	155.7	173.2	155.7	173.2	155.4	173.2	9.6	-4.4	0.	0.
9	152.7	169.2	152.7	169.2	152.5	169.1	7.8	-3.5	0.	0.
10	148.8	164.3	148.8	164.3	148.5	164.3	9.8	-2.3	0.	0.
11	146.4	162.5	146.4	162.5	146.1	162.4	8.4	5.6	0.	0.

RP	ABS MACH NO		REL MACH NO		MERID MACH NO		MERID PEAK SS	
	IN	OUT	IN	OUT	IN	OUT	VEL R	MACH NO
1	0.454	0.523	0.454	0.523	0.454	0.523	1.146	0.454
2	0.476	0.544	0.476	0.544	0.476	0.544	1.137	0.476
3	0.486	0.556	0.486	0.556	0.486	0.556	1.138	0.486
4	0.484	0.556	0.484	0.556	0.484	0.556	1.143	0.484
5	0.483	0.555	0.483	0.555	0.483	0.555	1.142	0.483
6	0.481	0.551	0.481	0.551	0.480	0.551	1.141	0.481
7	0.479	0.548	0.479	0.548	0.479	0.548	1.138	0.479
8	0.468	0.523	0.468	0.523	0.467	0.522	1.115	0.468
9	0.458	0.510	0.458	0.510	0.458	0.510	1.109	0.458
10	0.446	0.494	0.446	0.494	0.445	0.494	1.106	0.446
11	0.438	0.488	0.438	0.488	0.437	0.488	1.111	0.438

RP	PERCENT SPAN	INCIDENCE		DEV	D-FACT	EFF	LOSS COEFF		LOSS PARAM	
		MEAN	SS				TOT	PROF	TOT	PROF
1	5.00	-0.9	-12.9	-0.7	-0.145	0.	0.075	0.075	0.038	0.038
2	10.00	0.2	-11.8	-0.7	-0.129	0.	0.048	0.048	0.024	0.024
3	20.00	0.	-12.0	-0.4	-0.134	0.	0.039	0.039	0.018	0.018
4	30.00	0.9	-11.1	-0.3	-0.133	0.	0.038	0.038	0.017	0.017
5	38.00	1.2	-10.8	-0.2	-0.131	0.	0.045	0.045	0.019	0.019
6	46.00	1.5	-10.5	-0.0	-0.130	0.	0.051	0.051	0.020	0.020
7	50.00	2.1	-9.9	-0.1	-0.123	0.	0.064	0.064	0.024	0.024
8	70.00	3.5	-8.5	-1.5	-0.084	0.	0.152	0.152	0.049	0.049
9	80.00	2.9	-9.1	-1.2	-0.087	0.	0.165	0.165	0.048	0.048
10	90.00	3.8	-8.2	-0.8	-0.084	0.	0.183	0.183	0.046	0.046
11	95.00	3.3	-8.7	2.0	-0.107	0.	0.182	0.182	0.043	0.043

TABLE VII. - Continued.

(c) Reading 749

RP	RADII		ABS BETAM		REL BETAM		TOTAL TEMP		TOTAL PRESS	
	IN	OUT	IN	OUT	IN	OUT	IN	RATIO	IN	RATIO
1	25.072	24.971	-1.7	-0.6	-1.7	-0.6	289.0	1.003	10.01	0.992
2	24.412	24.354	-1.1	-0.6	-1.1	-0.6	288.7	1.003	10.14	0.993
3	23.058	23.096	-0.1	-0.0	-0.1	-0.0	288.4	1.003	10.14	0.994
4	21.659	21.806	1.1	-0.0	1.1	-0.0	288.0	1.003	10.14	0.995
5	20.508	20.752	1.1	0.2	1.1	0.2	287.9	1.003	10.14	0.995
6	19.334	19.682	1.1	0.1	1.1	0.1	287.9	1.003	10.14	0.993
7	18.738	19.139	2.8	-0.1	2.8	-0.1	287.9	1.003	10.14	0.992
8	15.624	16.350	3.5	-1.6	3.5	-1.6	287.8	1.002	10.14	0.985
9	13.960	14.889	3.1	-1.1	3.1	-1.1	287.8	1.002	10.14	0.984
10	12.192	13.365	2.9	-0.4	2.9	-0.4	288.0	1.002	10.14	0.982
11	11.255	12.573	3.0	2.3	3.0	2.3	288.8	1.000	10.14	0.981

RP	ABS VEL		REL VEL		MERID VEL		TANG VEL		WHEEL SPEED	
	IN	OUT	IN	OUT	IN	OUT	IN	OUT	IN	OUT
1	144.3	164.0	144.3	164.0	144.2	164.0	-4.2	-1.7	0.	0.
2	151.6	170.4	151.6	170.4	151.6	170.4	-2.8	-1.7	0.	0.
3	155.1	174.0	155.1	174.0	155.1	174.0	-0.2	-0.1	0.	0.
4	154.1	174.0	154.1	174.0	154.1	174.0	2.8	-0.0	0.	0.
5	153.9	174.0	153.9	174.0	153.8	174.0	3.0	0.5	0.	0.
6	153.1	172.9	153.1	172.9	153.1	172.9	2.8	0.3	0.	0.
7	152.6	172.1	152.6	172.1	152.4	172.1	7.4	-0.2	0.	0.
8	148.6	166.1	148.6	166.1	148.3	166.1	9.1	-4.5	0.	0.
9	145.8	162.1	145.8	162.1	145.6	162.1	7.9	-3.3	0.	0.
10	142.1	156.9	142.1	156.9	141.9	156.9	7.2	-1.0	0.	0.
11	140.0	154.7	140.0	154.7	139.8	154.6	7.3	6.2	0.	0.

RP	ABS MACH NO		REL MACH NO		MERID MACH NO		MERID PEAK SS	
	IN	OUT	IN	OUT	IN	OUT	VEL R	MACH NO
1	0.431	0.492	0.431	0.492	0.431	0.492	1.137	0.431
2	0.454	0.512	0.454	0.512	0.454	0.512	1.124	0.454
3	0.465	0.524	0.465	0.524	0.465	0.524	1.122	0.465
4	0.462	0.524	0.462	0.524	0.462	0.524	1.130	0.462
5	0.462	0.524	0.462	0.524	0.462	0.524	1.131	0.462
6	0.459	0.521	0.459	0.521	0.459	0.521	1.130	0.459
7	0.458	0.518	0.458	0.518	0.457	0.518	1.129	0.458
8	0.445	0.500	0.445	0.500	0.445	0.500	1.120	0.445
9	0.437	0.487	0.437	0.487	0.436	0.487	1.113	0.437
10	0.425	0.471	0.425	0.471	0.424	0.471	1.106	0.425
11	0.418	0.464	0.418	0.464	0.418	0.463	1.106	0.418

RP	PERCENT SPAN	INCIDENCE		DEV	D-FACT	EFF	LOSS COEFF		LOSS PARAM	
		MEAN	SS				TOT	PROF	TOT	PROF
1	5.00	-1.7	-13.7	-0.6	-0.128	0.	0.068	0.068	0.034	0.034
2	10.00	-1.1	-13.1	-0.6	-0.120	0.	0.051	0.051	0.025	0.025
3	20.00	-0.1	-12.1	-0.0	-0.121	0.	0.047	0.047	0.022	0.022
4	30.00	1.1	-10.9	-0.0	-0.121	0.	0.039	0.039	0.017	0.017
5	38.00	1.1	-10.9	0.2	-0.124	0.	0.039	0.039	0.016	0.016
6	46.00	1.1	-10.9	0.1	-0.123	0.	0.050	0.050	0.020	0.020
7	50.00	2.8	-9.2	-0.1	-0.109	0.	0.059	0.059	0.022	0.022
8	70.00	3.5	-8.5	-1.6	-0.089	0.	0.117	0.117	0.038	0.038
9	80.00	3.1	-8.9	-1.2	-0.090	0.	0.129	0.129	0.037	0.037
10	90.00	2.9	-9.1	-0.4	-0.090	0.	0.158	0.158	0.040	0.040
11	95.00	3.0	-9.0	2.3	-0.105	0.	0.164	0.164	0.039	0.039

TABLE VII. - Continued.

(d) Reading 760

RP	RADII		ABS BETAM		REL BETAM		TOTAL TEMP		TOTAL PRESS	
	IN	OUT	IN	OUT	IN	OUT	IN	RATIO	IN	RATIO
1	25.072	24.971	-1.7	-0.6	-1.7	-0.6	289.0	1.003	10.03	0.992
2	24.412	24.354	-1.2	0.0	-1.2	0.0	288.6	1.003	10.14	0.993
3	23.058	23.096	-0.5	0.2	-0.5	0.2	288.4	1.003	10.14	0.994
4	21.659	21.806	0.6	0.0	0.6	0.0	288.0	1.003	10.14	0.995
5	20.508	20.752	0.9	0.3	0.9	0.3	288.0	1.003	10.14	0.994
6	19.334	19.682	0.9	-0.1	0.9	-0.1	287.9	1.003	10.14	0.994
7	18.738	19.139	2.3	-0.3	2.3	-0.3	287.9	1.003	10.15	0.993
8	15.624	16.350	3.0	-1.8	3.0	-1.8	287.8	1.002	10.14	0.987
9	13.960	14.889	3.7	-1.1	3.7	-1.1	287.8	1.002	10.14	0.988
10	12.192	13.365	3.4	-0.5	3.4	-0.5	288.0	1.001	10.14	0.983
11	11.255	12.573	3.2	2.8	3.2	2.8	288.8	1.000	10.14	0.983

RP	ABS VEL		REL VEL		MERID VEL		TANG VEL		WHEEL SPEED	
	IN	OUT	IN	OUT	IN	OUT	IN	OUT	IN	OUT
1	140.9	159.1	140.9	159.1	140.9	159.1	-4.1	-1.8	0.	0.
2	147.4	164.8	147.4	164.8	147.4	164.8	-3.2	0.1	0.	0.
3	150.4	168.4	150.4	168.4	150.4	168.4	-1.4	0.5	0.	0.
4	149.6	168.6	149.6	168.6	149.6	168.6	1.5	0.1	0.	0.
5	149.4	168.6	149.4	168.6	149.4	168.6	2.2	0.8	0.	0.
6	148.9	167.7	148.9	167.7	148.8	167.7	2.3	-0.2	0.	0.
7	148.7	166.9	148.7	166.9	148.5	166.9	5.9	-0.7	0.	0.
8	145.3	161.9	145.3	161.9	145.1	161.8	7.7	-5.0	0.	0.
9	142.5	158.7	142.5	158.7	142.2	158.7	9.3	-3.0	0.	0.
10	138.9	153.1	138.9	153.1	138.6	153.1	8.2	-1.5	0.	0.
11	136.6	150.6	136.6	150.6	136.4	150.4	7.7	7.3	0.	0.

RP	ABS MACH NO		REL MACH NO		MERID MACH NO		MERID PEAK SS	
	IN	OUT	IN	OUT	IN	OUT	VEL R	MACH NO
1	0.421	0.477	0.421	0.477	0.421	0.477	1.130	0.421
2	0.441	0.495	0.441	0.495	0.441	0.495	1.119	0.441
3	0.451	0.506	0.451	0.506	0.451	0.506	1.120	0.451
4	0.448	0.507	0.448	0.507	0.448	0.507	1.127	0.448
5	0.448	0.507	0.448	0.507	0.448	0.507	1.128	0.448
6	0.446	0.505	0.446	0.505	0.446	0.505	1.127	0.446
7	0.446	0.502	0.446	0.502	0.445	0.502	1.123	0.446
8	0.435	0.487	0.435	0.487	0.435	0.486	1.115	0.435
9	0.427	0.477	0.427	0.477	0.426	0.476	1.116	0.427
10	0.415	0.459	0.415	0.459	0.414	0.459	1.104	0.415
11	0.408	0.451	0.408	0.451	0.407	0.450	1.103	0.408

RP	PERCENT		INCIDENCE		DEV	D-FACT	EFF	LOSS COEFF		LOSS PARAM	
	SPAN	MEAN	SS	TOT				PROF	TOT	PROF	
1	5.00	-1.7	-13.7	-0.6	-0.121	0.	0.071	0.071	0.036	0.036	
2	10.00	-1.2	-13.2	0.0	-0.107	0.	0.056	0.056	0.028	0.028	
3	20.00	-0.5	-12.5	0.2	-0.114	0.	0.048	0.048	0.022	0.022	
4	30.00	0.6	-11.4	0.0	-0.123	0.	0.036	0.036	0.016	0.016	
5	38.00	0.9	-11.1	0.3	-0.124	0.	0.043	0.043	0.018	0.018	
6	46.00	0.9	-11.1	-0.1	-0.120	0.	0.045	0.045	0.018	0.018	
7	50.00	2.3	-9.7	-0.3	-0.105	0.	0.058	0.058	0.022	0.022	
8	70.00	3.0	-9.0	-1.8	-0.087	0.	0.108	0.108	0.035	0.035	
9	80.00	3.7	-8.3	-1.1	-0.089	0.	0.101	0.101	0.029	0.029	
10	90.00	3.4	-8.6	-0.6	-0.085	0.	0.149	0.149	0.038	0.038	
11	95.00	3.2	-8.8	2.8	-0.102	0.	0.156	0.156	0.037	0.037	

TABLE VII. - Continued.

(e) Reading 771

RP	RADII		ABS BETAM		REL BETAM		TOTAL TEMP		TOTAL PRESS	
	IN	OUT	IN	OUT	IN	OUT	IN	RATIO	IN	RATIO
1	25.072	24.971	-1.7	-0.4	-1.7	-0.4	289.0	1.002	10.03	0.994
2	24.412	24.354	-0.7	-0.2	-0.7	-0.2	288.7	1.003	10.14	0.993
3	23.058	23.096	0.1	0.7	0.1	0.7	288.4	1.003	10.14	0.994
4	21.659	21.806	0.5	0.3	0.5	0.3	288.1	1.003	10.14	0.996
5	20.508	20.752	0.8	0.2	0.8	0.2	288.1	1.003	10.14	0.995
6	19.334	19.682	2.1	-0.2	2.1	-0.2	288.0	1.003	10.14	0.994
7	18.738	19.139	2.1	-0.6	2.1	-0.6	287.9	1.003	10.14	0.994
8	15.624	16.350	2.9	-2.0	2.9	-2.0	287.7	1.002	10.14	0.990
9	13.960	14.889	3.4	-1.1	3.4	-1.1	287.7	1.002	10.14	0.991
10	12.192	13.365	4.0	-0.6	4.0	-0.6	287.9	1.002	10.14	0.987
11	11.255	12.573	3.0	2.8	3.0	2.8	288.6	1.000	10.14	0.986

RP	ABS VEL		REL VEL		MERID VEL		TANG VEL		WHEEL SPEED	
	IN	OUT	IN	OUT	IN	OUT	IN	OUT	IN	OUT
1	133.4	150.0	133.4	150.0	133.4	150.0	-4.1	-1.1	0.	0.
2	140.5	155.5	140.5	155.5	140.5	155.5	-1.8	-0.7	0.	0.
3	143.9	159.0	143.9	159.0	143.9	159.0	0.3	2.1	0.	0.
4	142.8	159.2	142.8	159.2	142.8	159.2	1.2	0.7	0.	0.
5	142.6	159.2	142.6	159.2	142.6	159.2	2.0	0.7	0.	0.
6	141.9	158.5	141.9	158.5	141.8	158.5	5.3	-0.7	0.	0.
7	141.5	158.1	141.5	158.1	141.4	158.1	5.2	-1.6	0.	0.
8	138.1	154.6	138.1	154.6	137.9	154.5	7.0	-5.3	0.	0.
9	135.5	151.4	135.5	151.4	135.3	151.4	8.0	-2.8	0.	0.
10	132.2	146.2	132.2	146.2	131.9	146.2	9.2	-1.5	0.	0.
11	130.3	143.5	130.3	143.5	130.1	143.3	6.7	6.9	0.	0.

RP	ABS MACH NO		REL MACH NO		MERID MACH NO		MERID PEAK SS	
	IN	OUT	IN	OUT	IN	OUT	VEL R	MACH NO
1	0.398	0.448	0.398	0.448	0.397	0.448	1.125	0.398
2	0.420	0.466	0.420	0.466	0.420	0.466	1.106	0.420
3	0.430	0.477	0.430	0.477	0.430	0.477	1.105	0.430
4	0.427	0.478	0.427	0.478	0.427	0.478	1.115	0.427
5	0.427	0.478	0.427	0.478	0.427	0.478	1.116	0.427
6	0.425	0.476	0.425	0.476	0.424	0.476	1.117	0.425
7	0.423	0.474	0.423	0.474	0.423	0.474	1.118	0.423
8	0.413	0.464	0.413	0.464	0.412	0.464	1.120	0.413
9	0.405	0.454	0.405	0.454	0.404	0.454	1.119	0.405
10	0.395	0.438	0.395	0.438	0.394	0.438	1.109	0.395
11	0.388	0.429	0.388	0.429	0.388	0.428	1.102	0.388

RP	PERCENT SPAN	INCIDENCE		DEV	D-FACT	EFF	LOSS COEFF		LOSS PARAM	
		MEAN	SS				TOT	PROF	TOT	PROF
1	5.00	-1.7	-13.7	-0.4	-0.113	0.	0.060	0.060	0.031	0.031
2	10.00	-0.7	-12.7	-0.2	-0.102	0.	0.060	0.060	0.030	0.030
3	20.00	0.1	-11.9	0.7	-0.099	0.	0.051	0.051	0.024	0.024
4	30.00	0.5	-11.5	0.3	-0.113	0.	0.038	0.038	0.017	0.017
5	38.00	0.8	-11.2	0.2	-0.112	0.	0.042	0.042	0.017	0.017
6	46.00	2.1	-9.9	-0.2	-0.100	0.	0.048	0.048	0.019	0.019
7	50.00	2.1	-9.9	-0.6	-0.099	0.	0.048	0.048	0.018	0.018
8	70.00	2.9	-9.1	-2.0	-0.091	0.	0.087	0.087	0.028	0.028
9	80.00	3.4	-8.6	-1.1	-0.095	0.	0.084	0.084	0.024	0.024
10	90.00	3.9	-8.1	-0.6	-0.087	0.	0.125	0.125	0.032	0.032
11	95.00	2.9	-9.1	2.8	-0.100	0.	0.137	0.137	0.032	0.032

TABLE VII. - Continued.

(f) Reading 785

RP	RADII		ABS BETAM		REL BETAM		TOTAL TEMP		TOTAL PRESS	
	IN	OUT	IN	OUT	IN	OUT	IN	RATIO	IN	RATIO
1	25.072	24.971	-2.4	0.4	-2.4	0.4	289.3	1.001	10.04	0.991
2	24.412	24.354	-2.3	1.8	-2.3	1.8	289.7	1.001	10.14	0.995
3	23.058	23.096	-1.5	2.9	-1.5	2.9	289.3	1.002	10.14	0.994
4	21.659	21.806	-0.5	2.6	-0.5	2.6	288.2	1.003	10.14	0.996
5	20.508	20.752	0.9	2.2	0.9	2.2	287.9	1.002	10.14	0.997
6	19.334	19.682	0.2	1.8	0.2	1.8	287.7	1.002	10.14	0.997
7	18.738	19.139	1.1	1.4	1.1	1.4	287.7	1.002	10.14	0.998
8	15.624	16.350	2.9	-0.1	2.9	-0.1	287.2	1.002	10.14	0.996
9	13.960	14.889	2.4	1.1	2.4	1.1	287.3	1.001	10.14	0.995
10	12.192	13.365	1.8	1.5	1.8	1.5	287.6	1.001	10.14	0.995
11	11.255	12.573	1.4	1.1	1.4	1.1	287.9	1.001	10.14	0.992

RP	ABS VEL		REL VEL		MERID VEL		TANG VEL		WHEEL SPEED	
	IN	OUT	IN	OUT	IN	OUT	IN	OUT	IN	OUT
1	126.7	138.3	126.7	138.3	126.6	138.3	-5.4	0.8	0.	0.
2	133.4	145.7	133.4	145.7	133.3	145.6	-5.4	4.6	0.	0.
3	136.5	149.7	136.5	149.7	136.5	149.5	-3.6	7.6	0.	0.
4	135.4	149.8	135.4	149.8	135.4	149.6	-1.1	6.9	0.	0.
5	135.2	150.4	135.2	150.4	135.1	150.3	2.1	5.8	0.	0.
6	134.6	150.1	134.6	150.1	134.6	150.1	0.5	4.6	0.	0.
7	134.2	149.9	134.2	149.9	134.2	149.9	2.6	3.7	0.	0.
8	131.2	146.3	131.2	146.3	131.0	146.3	6.6	-0.4	0.	0.
9	128.7	143.3	128.7	143.3	128.6	143.3	5.4	2.7	0.	0.
10	125.4	138.7	125.4	138.7	125.3	138.6	3.9	3.7	0.	0.
11	123.4	134.6	123.4	134.6	123.4	134.5	3.0	2.5	0.	0.

RP	ABS MACH NO		REL MACH NO		MERID MACH NO		MERID PEAK SS	
	IN	OUT	IN	OUT	IN	OUT	VEL R	MACH NO
1	0.377	0.412	0.377	0.412	0.376	0.412	1.093	0.377
2	0.397	0.435	0.397	0.435	0.397	0.434	1.092	0.397
3	0.407	0.447	0.407	0.447	0.407	0.447	1.095	0.407
4	0.404	0.448	0.404	0.448	0.404	0.448	1.105	0.404
5	0.404	0.450	0.404	0.450	0.404	0.450	1.112	0.404
6	0.402	0.450	0.402	0.450	0.402	0.450	1.115	0.402
7	0.401	0.449	0.401	0.449	0.401	0.449	1.117	0.401
8	0.392	0.439	0.392	0.439	0.391	0.439	1.117	0.392
9	0.384	0.429	0.384	0.429	0.384	0.429	1.114	0.384
10	0.374	0.415	0.374	0.415	0.374	0.414	1.106	0.374
11	0.368	0.402	0.368	0.402	0.368	0.402	1.090	0.368

RP	PERCENT	INCIDENCE		DEV	D-FACT	EFF	LOSS COEFF		LOSS PARAM	
	SPAN	MEAN	SS				TOT	PROF	TOT	PROF
1	5.00	-2.4	-14.4	0.4	-0.067	0.	0.097	0.097	0.049	0.049
2	10.00	-2.3	-14.3	1.8	-0.055	0.	0.053	0.053	0.026	0.026
3	20.00	-1.5	-13.5	2.9	-0.059	0.	0.055	0.055	0.025	0.025
4	30.00	-0.5	-12.5	2.6	-0.080	0.	0.037	0.037	0.016	0.016
5	38.00	0.9	-11.1	2.2	-0.101	0.	0.025	0.025	0.010	0.010
6	46.00	0.2	-11.8	1.8	-0.103	0.	0.024	0.024	0.010	0.010
7	50.00	1.1	-10.9	1.4	-0.114	0.	0.023	0.023	0.009	0.009
8	70.00	2.9	-9.1	-0.2	-0.099	0.	0.041	0.041	0.013	0.013
9	80.00	2.4	-9.6	1.1	-0.108	0.	0.047	0.047	0.014	0.014
10	90.00	1.8	-10.2	1.5	-0.106	0.	0.056	0.056	0.014	0.014
11	95.00	1.4	-10.6	1.1	-0.090	0.	0.092	0.092	0.022	0.022

TABLE VII. - Continued.

(g) Reading 796

RP	RADI		ABS BETAM		REL BETAM		TOTAL TEMP		TOTAL PRESS	
	IN	OUT	IN	OUT	IN	OUT	IN	RATIO	IN	RATIO
1	25.072	24.971	-1.1	-0.1	-1.1	-0.1	289.1	1.003	10.01	0.988
2	24.412	24.354	-1.9	0.8	-1.9	0.8	288.7	1.004	10.14	0.994
3	23.058	23.096	-1.7	1.5	-1.7	1.5	288.4	1.003	10.14	0.995
4	21.659	21.806	-0.5	1.6	-0.5	1.6	288.0	1.003	10.14	0.996
5	20.508	20.752	0.7	1.8	0.7	1.8	288.0	1.003	10.14	0.996
6	19.334	19.682	1.5	1.6	1.5	1.6	288.0	1.003	10.14	0.996
7	18.738	19.139	1.1	1.6	1.1	1.6	287.9	1.003	10.14	0.996
8	15.624	16.350	0.9	0.7	0.9	0.7	287.7	1.003	10.14	0.993
9	13.960	14.889	0.8	1.2	0.8	1.2	287.8	1.002	10.14	0.991
10	12.192	13.365	1.7	1.4	1.7	1.4	288.1	1.002	10.14	0.990
11	11.255	12.573	1.5	0.1	1.5	0.1	288.3	1.002	10.14	0.980

RP	ABS VEL		REL VEL		MERID VEL		TANG VEL		WHEEL SPEED	
	IN	OUT	IN	OUT	IN	OUT	IN	OUT	IN	OUT
1	152.8	170.8	152.8	170.8	152.8	170.8	-3.1	-0.3	0.	0.
2	160.0	178.7	160.0	178.7	159.9	178.7	-5.4	2.5	0.	0.
3	163.3	183.3	163.3	183.3	163.2	183.2	-4.8	4.8	0.	0.
4	162.1	182.9	162.1	182.9	162.1	182.9	-1.5	5.1	0.	0.
5	162.0	183.0	162.0	183.0	161.9	182.9	2.1	5.8	0.	0.
6	161.3	182.4	161.3	182.4	161.2	182.3	4.3	5.2	0.	0.
7	160.7	181.9	160.7	181.9	160.6	181.8	3.2	5.2	0.	0.
8	156.5	176.4	156.5	176.4	156.5	176.4	2.5	2.2	0.	0.
9	153.6	172.9	153.6	172.9	153.5	172.8	2.2	3.7	0.	0.
10	149.4	166.2	149.4	166.2	149.4	166.2	4.5	4.2	0.	0.
11	146.8	158.6	146.8	158.6	146.7	158.6	3.8	0.4	0.	0.

RP	ABS MACH NO		REL MACH NO		MERID MACH NO		MERID PEAK SS	
	IN	OUT	IN	OUT	IN	OUT	VEL R	MACH NO
1	0.458	0.513	0.458	0.513	0.457	0.513	1.118	0.458
2	0.480	0.539	0.480	0.539	0.480	0.539	1.118	0.480
3	0.491	0.554	0.491	0.554	0.491	0.554	1.123	0.491
4	0.488	0.553	0.488	0.553	0.488	0.553	1.128	0.488
5	0.487	0.553	0.487	0.553	0.487	0.553	1.130	0.487
6	0.485	0.551	0.485	0.551	0.485	0.551	1.131	0.485
7	0.483	0.550	0.483	0.550	0.483	0.550	1.132	0.483
8	0.470	0.532	0.470	0.532	0.470	0.532	1.127	0.470
9	0.461	0.521	0.461	0.521	0.461	0.521	1.126	0.461
10	0.448	0.500	0.448	0.500	0.448	0.500	1.113	0.448
11	0.439	0.476	0.439	0.476	0.439	0.476	1.081	0.439

RP	PERCENT	INCIDENCE		DEV	D-FACT	EFF	LOSS COEFF		LOSS PARAM	
	SPAN	MEAN	SS				TOT	PROF	TOT	PROF
1	5.00	-1.1	-13.1	-0.1	-0.108	0.	0.089	0.089	0.045	0.045
2	10.00	-1.9	-13.9	0.8	-0.093	0.	0.039	0.039	0.019	0.019
3	20.00	-1.7	-13.7	1.5	-0.095	0.	0.030	0.030	0.014	0.014
4	30.00	-0.5	-12.5	1.6	-0.111	0.	0.025	0.025	0.011	0.011
5	38.00	0.7	-11.3	1.8	-0.120	0.	0.027	0.027	0.011	0.011
6	46.00	1.5	-10.5	1.6	-0.128	0.	0.028	0.028	0.011	0.011
7	50.00	1.1	-10.9	1.6	-0.127	0.	0.027	0.027	0.010	0.010
8	70.00	0.9	-11.1	0.7	-0.127	0.	0.052	0.052	0.017	0.017
9	80.00	0.8	-11.2	1.2	-0.123	0.	0.064	0.064	0.018	0.018
10	90.00	1.7	-10.3	1.5	-0.112	0.	0.080	0.080	0.020	0.020
11	95.00	1.5	-10.5	0.1	-0.076	0.	0.158	0.158	0.037	0.037

TABLE VII. - Continued.

(h) Reading 808

RP	RADII		ABS BETAM		REL BETAM		TOTAL TEMP		TOTAL PRESS	
	IN	OUT	IN	OUT	IN	OUT	IN	RATIO	IN	RATIO
1	25.072	24.971	-2.5	0.0	-2.5	0.0	289.0	1.003	10.02	0.989
2	24.412	24.354	-2.1	1.2	-2.1	1.2	288.7	1.003	10.14	0.995
3	23.058	23.096	-0.3	1.7	-0.3	1.7	288.4	1.003	10.14	0.994
4	21.659	21.806	-0.4	1.4	-0.4	1.4	288.0	1.003	10.14	0.996
5	20.508	20.752	-0.7	1.8	-0.7	1.8	288.0	1.003	10.14	0.996
6	19.334	19.682	0.4	1.8	0.4	1.8	287.9	1.003	10.14	0.996
7	18.738	19.139	0.6	1.6	0.6	1.6	287.9	1.003	10.14	0.996
8	15.624	16.350	1.1	0.4	1.1	0.4	287.7	1.002	10.14	0.993
9	13.960	14.889	1.2	0.9	1.2	0.9	287.9	1.002	10.14	0.993
10	12.192	13.365	2.0	1.3	2.0	1.3	288.0	1.002	10.14	0.989
11	11.255	12.573	1.4	0.2	1.4	0.2	288.4	1.001	10.14	0.983

RP	ABS VEL		REL VEL		MERID VEL		TANG VEL		WHEEL SPEED	
	IN	OUT	IN	OUT	IN	OUT	IN	OUT	IN	OUT
1	149.3	166.2	149.3	166.2	149.2	166.2	-6.5	0.1	0.	0.
2	155.9	173.5	155.9	173.5	155.8	173.4	-5.8	3.6	0.	0.
3	159.1	177.7	159.1	177.7	159.1	177.6	-0.9	5.4	0.	0.
4	158.1	177.6	158.1	177.6	158.1	177.5	-1.0	4.5	0.	0.
5	157.9	177.7	157.9	177.7	157.9	177.6	-1.8	5.6	0.	0.
6	157.2	177.1	157.2	177.1	157.2	177.0	1.1	5.7	0.	0.
7	156.7	176.7	156.7	176.7	156.7	176.6	1.5	4.9	0.	0.
8	152.6	171.9	152.6	171.9	152.5	171.9	2.8	1.3	0.	0.
9	149.5	168.4	149.5	168.4	149.4	168.3	3.0	2.7	0.	0.
10	145.5	161.9	145.5	161.9	145.5	161.9	5.1	3.6	0.	0.
11	143.1	155.8	143.1	155.8	143.1	155.8	3.5	0.6	0.	0.

RP	ABS MACH NO		REL MACH NO		MERID MACH NO		MERID PEAK SS	
	IN	OUT	IN	OUT	IN	OUT	VEL R	MACH NO
1	0.447	0.499	0.447	0.499	0.446	0.499	1.114	0.447
2	0.468	0.522	0.468	0.522	0.467	0.522	1.113	0.468
3	0.478	0.536	0.478	0.536	0.478	0.535	1.116	0.478
4	0.475	0.536	0.475	0.536	0.475	0.536	1.123	0.475
5	0.474	0.536	0.474	0.536	0.474	0.536	1.125	0.474
6	0.472	0.534	0.472	0.534	0.472	0.534	1.125	0.472
7	0.471	0.533	0.471	0.533	0.471	0.533	1.127	0.471
8	0.458	0.518	0.458	0.518	0.458	0.518	1.127	0.458
9	0.448	0.507	0.448	0.507	0.448	0.507	1.127	0.448
10	0.436	0.487	0.436	0.487	0.436	0.486	1.113	0.436
11	0.428	0.467	0.428	0.467	0.428	0.467	1.089	0.428

RP	PERCENT	INCIDENCE		DEV	D-FACT	EFF	LOSS COEFF		LOSS PARAM	
	SPAN	MEAN	SS				TOT	PROF	TOT	PROF
1	5.00	-2.5	-14.5	0.0	-0.091	0.	0.082	0.082	0.042	0.042
2	10.00	-2.1	-14.1	1.2	-0.083	0.	0.038	0.038	0.019	0.019
3	20.00	-0.3	-12.3	1.7	-0.098	0.	0.038	0.038	0.018	0.018
4	30.00	-0.4	-12.4	1.4	-0.108	0.	0.025	0.025	0.011	0.011
5	38.00	-0.7	-12.7	1.8	-0.106	0.	0.026	0.026	0.011	0.011
6	46.00	0.4	-11.6	1.8	-0.114	0.	0.029	0.029	0.011	0.011
7	50.00	0.6	-11.4	1.6	-0.119	0.	0.028	0.028	0.011	0.011
8	70.00	1.1	-10.9	0.4	-0.124	0.	0.052	0.052	0.017	0.017
9	80.00	1.2	-10.8	0.9	-0.126	0.	0.055	0.055	0.016	0.016
10	90.00	2.0	-10.0	1.3	-0.110	0.	0.088	0.088	0.022	0.022
11	95.00	1.4	-10.6	0.2	-0.084	0.	0.146	0.146	0.034	0.034

TABLE VII. - Continued.

(i) Reading 819

RP	RADII		ABS BETAM		REL BETAM		TOTAL TEMP		TOTAL PRESS	
	IN	OUT	IN	OUT	IN	OUT	IN	RATIO	IN	RATIO
1	25.072	24.971	-2.1	0.2	-2.1	0.2	289.3	1.002	10.02	0.990
2	24.412	24.354	-2.0	1.2	-2.0	1.2	288.6	1.003	10.14	0.995
3	23.058	23.096	-1.8	1.9	-1.8	1.9	288.4	1.004	10.14	0.995
4	21.659	21.806	-0.1	1.7	-0.1	1.7	287.8	1.003	10.14	0.996
5	20.508	20.752	-0.9	1.9	-0.9	1.9	288.2	1.002	10.14	0.996
6	19.334	19.682	-0.2	1.7	-0.2	1.7	287.8	1.003	10.14	0.997
7	18.738	19.139	1.5	1.6	1.5	1.6	287.8	1.003	10.14	0.997
8	15.624	16.350	1.2	0.2	1.2	0.2	287.8	1.002	10.14	0.994
9	13.960	14.889	2.2	1.2	2.2	1.2	287.9	1.002	10.14	0.994
10	12.192	13.365	2.0	1.1	2.0	1.1	288.2	1.001	10.14	0.992
11	11.255	12.573	1.5	0.1	1.5	0.1	288.4	1.001	10.14	0.986

RP	ABS VEL		REL VEL		MERID VEL		TANG VEL		WHEEL SPEED	
	IN	OUT	IN	OUT	IN	OUT	IN	OUT	IN	OUT
1	143.3	158.7	143.3	158.7	143.2	158.7	-5.2	0.5	0.	0.
2	150.6	166.6	150.6	166.6	150.5	166.6	-5.4	3.6	0.	0.
3	154.0	171.0	154.0	171.0	153.9	170.9	-4.8	5.8	0.	0.
4	153.1	170.9	153.1	170.9	153.1	170.9	-0.4	5.2	0.	0.
5	152.9	171.2	152.9	171.2	152.9	171.1	-2.5	5.6	0.	0.
6	152.1	170.8	152.1	170.8	152.1	170.7	-0.4	5.0	0.	0.
7	151.7	170.6	151.7	170.6	151.7	170.5	3.8	4.6	0.	0.
8	147.9	166.4	147.9	166.4	147.9	166.4	3.2	0.7	0.	0.
9	145.2	163.0	145.2	163.0	145.1	163.0	5.7	3.3	0.	0.
10	141.4	157.1	141.4	157.1	141.3	157.1	5.0	3.1	0.	0.
11	138.8	151.3	138.8	151.3	138.8	151.3	3.6	0.2	0.	0.

RP	ABS MACH NO		REL MACH NO		MERID MACH NO		MERID PEAK SS	
	IN	OUT	IN	OUT	IN	OUT	VEL R	MACH NO
1	0.428	0.475	0.428	0.475	0.428	0.475	1.108	0.428
2	0.451	0.501	0.451	0.501	0.451	0.500	1.107	0.451
3	0.462	0.514	0.462	0.514	0.462	0.514	1.110	0.462
4	0.459	0.515	0.459	0.515	0.459	0.515	1.116	0.459
5	0.459	0.516	0.459	0.516	0.459	0.515	1.119	0.459
6	0.457	0.514	0.457	0.514	0.457	0.514	1.122	0.457
7	0.455	0.514	0.455	0.514	0.455	0.514	1.124	0.455
8	0.443	0.501	0.443	0.501	0.443	0.501	1.125	0.443
9	0.435	0.490	0.435	0.490	0.435	0.490	1.123	0.435
10	0.423	0.471	0.423	0.471	0.423	0.471	1.111	0.423
11	0.415	0.453	0.415	0.453	0.415	0.453	1.090	0.415

RP	PERCENT		INCIDENCE		DEV	D-FACT	EFF	LOSS COEFF		LOSS PARAM	
	SPAN	MEAN	SS	TOT				PROF	TOT	PROF	
1	5.00	-2.1	-14.1	0.2	-0.088	0.	0.085	0.085	0.043	0.043	
2	10.00	-2.0	-14.0	1.2	-0.077	0.	0.039	0.039	0.019	0.019	
3	20.00	-1.8	-13.8	1.9	-0.079	0.	0.037	0.037	0.017	0.017	
4	30.00	-0.1	-12.1	1.7	-0.101	0.	0.027	0.027	0.012	0.012	
5	38.00	-0.9	-12.9	1.9	-0.097	0.	0.026	0.026	0.011	0.011	
6	46.00	-0.2	-12.2	1.7	-0.108	0.	0.023	0.023	0.009	0.009	
7	50.00	1.5	-10.5	1.5	-0.122	0.	0.021	0.021	0.008	0.008	
8	70.00	1.2	-10.8	0.2	-0.119	0.	0.045	0.045	0.014	0.014	
9	80.00	2.2	-9.8	1.2	-0.119	0.	0.051	0.051	0.015	0.015	
10	90.00	2.0	-10.0	1.2	-0.108	0.	0.072	0.072	0.018	0.018	
11	95.00	1.5	-10.5	0.1	-0.085	0.	0.128	0.128	0.030	0.030	

TABLE VII. - Continued.

(j) Reading 830

RP	RADII		ABS BETAM		REL BETAM		TOTAL TEMP		TOTAL PRESS	
	IN	OUT	IN	OUT	IN	OUT	IN	RATIO	IN	RATIO
1	25.072	24.971	-2.7	0.2	-2.7	0.2	289.2	1.002	10.03	0.991
2	24.412	24.354	-2.5	1.6	-2.5	1.6	289.0	1.002	10.14	0.995
3	23.058	23.096	-1.6	2.6	-1.6	2.6	288.8	1.003	10.14	0.994
4	21.659	21.806	-0.6	2.0	-0.6	2.0	288.1	1.003	10.14	0.996
5	20.508	20.752	-0.2	1.9	-0.2	1.9	287.9	1.003	10.14	0.997
6	19.334	19.682	-0.5	1.7	-0.5	1.7	287.8	1.003	10.14	0.997
7	18.738	19.139	1.7	1.5	1.7	1.5	287.8	1.002	10.14	0.997
8	15.624	16.350	1.8	0.2	1.8	0.2	287.5	1.002	10.14	0.995
9	13.960	14.889	2.5	1.0	2.5	1.0	287.6	1.002	10.14	0.995
10	12.192	13.365	2.7	1.1	2.7	1.1	287.9	1.001	10.14	0.994
11	11.255	12.573	0.9	0.7	0.9	0.7	288.2	1.001	10.14	0.989

RP	ABS VEL		REL VEL		MERID VEL		TANG VEL		WHEEL SPEED	
	IN	OUT	IN	OUT	IN	OUT	IN	OUT	IN	OUT
1	136.8	150.6	136.8	150.6	136.6	150.6	-6.4	0.6	0.	0.
2	143.5	157.7	143.5	157.7	143.3	157.6	-6.3	4.5	0.	0.
3	146.6	161.6	146.6	161.6	146.5	161.4	-4.1	7.5	0.	0.
4	145.6	161.8	145.6	161.8	145.5	161.7	-1.5	5.5	0.	0.
5	145.4	162.3	145.4	162.3	145.4	162.2	-0.5	5.3	0.	0.
6	144.8	161.8	144.8	161.8	144.8	161.7	-1.3	4.9	0.	0.
7	144.3	161.5	144.3	161.5	144.2	161.4	4.3	4.3	0.	0.
8	140.2	157.3	140.2	157.3	140.1	157.3	4.4	0.4	0.	0.
9	137.6	154.4	137.6	154.4	137.5	154.3	6.0	2.8	0.	0.
10	134.3	149.0	134.3	149.0	134.1	149.0	6.3	3.0	0.	0.
11	131.9	143.8	131.9	143.8	131.9	143.8	2.0	1.7	0.	0.

RP	ABS MACH NO		REL MACH NO		MERID MACH NO		MERID PEAK SS	
	IN	OUT	IN	OUT	IN	OUT	VEL R	MACH NO
1	0.408	0.450	0.408	0.450	0.407	0.450	1.102	0.408
2	0.429	0.472	0.429	0.472	0.428	0.472	1.100	0.429
3	0.438	0.485	0.438	0.485	0.438	0.484	1.102	0.438
4	0.436	0.486	0.436	0.486	0.436	0.486	1.111	0.436
5	0.436	0.488	0.436	0.488	0.436	0.487	1.115	0.436
6	0.434	0.486	0.434	0.486	0.434	0.486	1.117	0.434
7	0.432	0.485	0.432	0.485	0.432	0.485	1.119	0.432
8	0.419	0.472	0.419	0.472	0.419	0.472	1.123	0.419
9	0.412	0.463	0.412	0.463	0.411	0.463	1.123	0.412
10	0.401	0.446	0.401	0.446	0.401	0.446	1.111	0.401
11	0.394	0.430	0.394	0.430	0.394	0.430	1.090	0.394

RP	PERCENT	INCIDENCE		DEV	D-FACT	EFF	LOSS COEFF		LOSS PARAM	
	SPAN	MEAN	SS				TOT	PROF	TOT	PROF
1	5.00	-2.7	-14.7	0.2	-0.075	0.	0.083	0.083	0.042	0.042
2	10.00	-2.5	-14.5	1.6	-0.062	0.	0.045	0.045	0.022	0.022
3	20.00	-1.6	-13.6	2.6	-0.066	0.	0.050	0.050	0.023	0.023
4	30.00	-0.6	-12.6	1.9	-0.090	0.	0.029	0.029	0.013	0.013
5	38.00	-0.2	-12.2	1.9	-0.099	0.	0.025	0.025	0.010	0.010
6	46.00	-0.5	-12.5	1.7	-0.100	0.	0.027	0.027	0.010	0.010
7	50.00	1.7	-10.3	1.5	-0.119	0.	0.026	0.026	0.010	0.010
8	70.00	1.8	-10.2	0.2	-0.113	0.	0.043	0.043	0.014	0.014
9	80.00	2.5	-9.5	1.1	-0.116	0.	0.046	0.046	0.013	0.013
10	90.00	2.7	-9.3	1.1	-0.104	0.	0.061	0.061	0.016	0.016
11	95.00	0.9	-11.1	0.7	-0.090	0.	0.111	0.111	0.026	0.026

TABLE VII. - Continued.

(k) Reading 845

RP	RADII		ABS BETAM		REL BETAM		TOTAL TEMP		TOTAL PRESS	
	IN	OUT	IN	OUT	IN	OUT	IN	RATIO	IN	RATIO
1	25.072	24.971	-2.0	-0.5	-2.0	-0.5	289.1	1.002	10.04	0.989
2	24.412	24.354	-1.5	0.3	-1.5	0.3	288.8	1.003	10.14	0.995
3	23.058	23.096	-1.1	1.3	-1.1	1.3	288.7	1.003	10.14	0.994
4	21.659	21.806	-0.8	0.9	-0.8	0.9	288.2	1.003	10.14	0.995
5	20.508	20.752	0.5	0.9	0.5	0.9	287.9	1.003	10.14	0.996
6	19.334	19.682	0.1	0.8	0.1	0.8	287.9	1.002	10.14	0.996
7	18.738	19.139	1.5	0.7	1.5	0.7	287.9	1.003	10.14	0.996
8	15.624	16.350	2.3	-0.3	2.3	-0.3	287.5	1.002	10.14	0.994
9	13.960	14.889	2.5	0.3	2.5	0.3	287.6	1.002	10.14	0.994
10	12.192	13.365	2.1	0.8	2.1	0.8	287.9	1.002	10.14	0.993
11	11.255	12.573	1.9	1.4	1.9	1.4	288.5	1.001	10.14	0.988

RP	ABS VEL		REL VEL		MERID VEL		TANG VEL		WHEEL SPEED	
	IN	OUT	IN	OUT	IN	OUT	IN	OUT	IN	OUT
1	141.9	156.0	141.9	156.0	141.8	155.9	-5.0	-1.4	0.	0.
2	147.8	163.3	147.8	163.3	147.8	163.3	-3.7	0.9	0.	0.
3	150.7	167.3	150.7	167.3	150.7	167.2	-2.9	3.8	0.	0.
4	150.0	167.2	150.0	167.2	149.9	167.2	-2.1	2.7	0.	0.
5	149.8	167.6	149.8	167.6	149.8	167.6	1.2	2.6	0.	0.
6	149.0	167.1	149.0	167.1	149.0	167.1	0.3	2.3	0.	0.
7	148.5	166.7	148.5	166.7	148.4	166.7	3.9	2.0	0.	0.
8	144.4	162.2	144.4	162.2	144.2	162.2	5.9	-1.0	0.	0.
9	141.5	158.7	141.5	158.7	141.4	158.7	6.1	0.8	0.	0.
10	137.9	153.5	137.9	153.5	137.8	153.5	5.2	2.1	0.	0.
11	135.8	148.8	135.8	148.8	135.7	148.7	4.6	3.5	0.	0.

RP	ABS MACH NO		REL MACH NO		MERID MACH NO		MERID PEAK SS	
	IN	OUT	IN	OUT	IN	OUT	VEL R	MACH NG
1	0.424	0.467	0.424	0.467	0.423	0.467	1.100	0.424
2	0.442	0.490	0.442	0.490	0.442	0.490	1.105	0.442
3	0.451	0.502	0.451	0.502	0.451	0.502	1.110	0.451
4	0.449	0.503	0.449	0.503	0.449	0.503	1.115	0.449
5	0.449	0.504	0.449	0.504	0.449	0.504	1.119	0.449
6	0.447	0.503	0.447	0.503	0.447	0.503	1.121	0.447
7	0.445	0.502	0.445	0.502	0.445	0.502	1.123	0.445
8	0.432	0.488	0.432	0.488	0.432	0.488	1.124	0.432
9	0.424	0.477	0.424	0.477	0.423	0.477	1.123	0.424
10	0.412	0.460	0.412	0.460	0.412	0.460	1.114	0.412
11	0.405	0.445	0.405	0.445	0.405	0.445	1.096	0.405

RP	PERCENT		INCIDENCE		DEV	D-FACT	EFF	LOSS COEFF		LOSS PARAM	
	SPAN	MEAN	SS	TOT				PROF	TOT	PROF	
1	5.00	-2.0	-14.0	-0.5	-0.086	0.	0.095	0.095	0.048	0.048	
2	10.00	-1.5	-13.5	0.3	-0.089	0.	0.042	0.042	0.021	0.021	
3	20.00	-1.1	-13.1	1.3	-0.089	0.	0.044	0.044	0.021	0.021	
4	30.00	-0.8	-12.8	0.9	-0.101	0.	0.037	0.037	0.016	0.016	
5	38.00	0.5	-11.5	0.9	-0.115	0.	0.029	0.029	0.012	0.012	
6	46.00	0.1	-11.9	0.8	-0.116	0.	0.030	0.030	0.012	0.012	
7	50.00	1.5	-10.5	0.7	-0.118	0.	0.030	0.030	0.011	0.011	
8	70.00	2.3	-9.7	-0.3	-0.108	0.	0.047	0.047	0.015	0.015	
9	80.00	2.4	-9.6	0.3	-0.112	0.	0.054	0.054	0.016	0.016	
10	90.00	2.1	-9.9	0.8	-0.108	0.	0.066	0.066	0.017	0.017	
11	95.00	1.9	-10.1	1.4	-0.095	0.	0.109	0.109	0.026	0.026	

TABLE VII. - Continued.

(ℓ) Reading 856

RP	RADII		ABS BETAM		REL BETAM		TOTAL TEMP		TOTAL PRESS	
	IN	OUT	IN	OUT	IN	OUT	IN	RATIO	IN	RATIO
1	25.072	24.971	-2.2	-0.5	-2.2	-0.5	289.1	1.003	10.03	0.990
2	24.412	24.354	-1.4	0.0	-1.4	0.0	288.8	1.003	10.13	0.994
3	23.058	23.096	-1.0	0.9	-1.0	0.9	288.5	1.003	10.14	0.994
4	21.659	21.806	-0.1	0.7	-0.1	0.7	288.1	1.003	10.14	0.995
5	20.508	20.752	-0.2	0.8	-0.2	0.8	288.0	1.003	10.14	0.996
6	19.334	19.682	1.3	0.7	1.3	0.7	287.9	1.003	10.14	0.996
7	18.738	19.139	1.4	0.7	1.4	0.7	287.8	1.003	10.14	0.996
8	15.624	16.350	1.5	-0.6	1.5	-0.6	287.7	1.002	10.14	0.993
9	13.960	14.889	2.3	-0.1	2.3	-0.1	287.7	1.002	10.14	0.993
10	12.192	13.365	2.5	0.9	2.5	0.9	288.0	1.002	10.14	0.990
11	11.255	12.573	2.2	1.0	2.2	1.0	288.5	1.001	10.14	0.985

RP	ABS VEL		REL VEL		MERID VEL		TANG VEL		WHEEL SPEED	
	IN	OUT	IN	OUT	IN	OUT	IN	OUT	IN	OUT
1	145.2	161.4	145.2	161.4	145.1	161.4	-5.6	-1.5	0.	0.
2	151.5	168.3	151.5	168.3	151.4	168.3	-3.7	0.1	0.	0.
3	154.5	172.2	154.5	172.2	154.5	172.1	-2.7	2.8	0.	0.
4	153.6	172.1	153.6	172.1	153.6	172.1	-0.3	2.1	0.	0.
5	153.4	172.4	153.4	172.4	153.4	172.4	-0.4	2.4	0.	0.
6	152.7	171.9	152.7	171.9	152.7	171.9	3.4	2.0	0.	0.
7	152.3	171.4	152.3	171.4	152.2	171.4	3.6	2.0	0.	0.
8	148.5	166.8	148.5	166.8	148.4	166.8	3.8	-1.7	0.	0.
9	145.5	163.1	145.5	163.1	145.4	163.1	5.9	-0.2	0.	0.
10	141.8	157.2	141.8	157.2	141.7	157.1	6.3	2.5	0.	0.
11	139.5	152.1	139.5	152.1	139.4	152.1	5.4	2.6	0.	0.

RP	ABS MACH NO		REL MACH NO		MERID MACH NO		MERID PEAK SS	
	IN	OUT	IN	OUT	IN	OUT	VEL R	MACH. NO
1	0.434	0.484	0.434	0.484	0.434	0.484	1.112	0.434
2	0.454	0.506	0.454	0.506	0.453	0.506	1.112	0.454
3	0.463	0.518	0.463	0.518	0.463	0.518	1.114	0.463
4	0.461	0.518	0.461	0.518	0.461	0.518	1.120	0.461
5	0.460	0.519	0.460	0.519	0.460	0.519	1.123	0.460
6	0.458	0.518	0.458	0.518	0.458	0.518	1.126	0.458
7	0.457	0.516	0.457	0.516	0.457	0.516	1.126	0.457
8	0.445	0.502	0.445	0.502	0.445	0.502	1.123	0.445
9	0.436	0.490	0.436	0.490	0.436	0.490	1.122	0.436
10	0.424	0.472	0.424	0.472	0.424	0.472	1.109	0.424
11	0.417	0.456	0.417	0.456	0.417	0.456	1.091	0.417

RP	PERCENT		INCIDENCE		DEV	D-FACT	EFF	LOSS COEFF		LOSS PARAM	
	SPAN	MEAN	SS	TOT				PROF	TOT	PROF	
1	5.00	-2.2	-14.2	-0.5	-0.097	0.	0.084	0.084	0.043	0.043	
2	10.00	-1.4	-13.4	0.0	-0.099	0.	0.044	0.044	0.022	0.022	
3	20.00	-1.0	-13.0	0.9	-0.098	0.	0.041	0.041	0.019	0.019	
4	30.00	-0.1	-12.1	0.7	-0.113	0.	0.034	0.034	0.015	0.015	
5	38.00	-0.2	-12.2	0.8	-0.116	0.	0.030	0.030	0.012	0.012	
6	46.00	1.3	-10.7	0.7	-0.122	0.	0.029	0.029	0.011	0.011	
7	50.00	1.4	-10.6	0.7	-0.122	0.	0.031	0.031	0.012	0.012	
8	70.00	1.5	-10.5	-0.6	-0.111	0.	0.051	0.051	0.016	0.016	
9	80.00	2.3	-9.7	-0.1	-0.109	0.	0.058	0.058	0.017	0.017	
10	90.00	2.5	-9.5	0.9	-0.102	0.	0.088	0.088	0.022	0.022	
11	95.00	2.2	-9.8	1.0	-0.086	0.	0.134	0.134	0.032	0.032	

TABLE VII. - Continued.

(m) Reading 867

RP	RADII		ABS BETAM		REL BETAM		TOTAL TEMP		TOTAL PRESS	
	IN	OUT	IN	OUT	IN	OUT	IN	RATIO	IN	RATIO
1	25.072	24.971	-1.6	-0.5	-1.6	-0.5	289.0	1.003	10.03	0.989
2	24.412	24.354	-1.5	0.1	-1.5	0.1	288.6	1.003	10.14	0.994
3	23.058	23.096	-1.5	0.9	-1.5	0.9	288.5	1.003	10.14	0.995
4	21.659	21.806	-0.4	0.6	-0.4	0.6	288.1	1.003	10.14	0.996
5	20.508	20.752	-0.5	0.8	-0.5	0.8	287.9	1.003	10.14	0.996
6	19.334	19.682	1.8	0.7	1.8	0.7	287.8	1.003	10.14	0.996
7	18.738	19.139	1.0	0.6	1.0	0.6	287.9	1.003	10.14	0.996
8	15.624	16.350	2.1	-0.5	2.1	-0.5	287.7	1.002	10.14	0.993
9	13.960	14.889	2.9	-0.0	2.9	-0.0	287.8	1.002	10.14	0.991
10	12.192	13.365	2.4	0.6	2.4	0.6	288.0	1.002	10.14	0.988
11	11.255	12.573	1.8	0.3	1.8	0.3	288.5	1.001	10.14	0.980

RP	ABS VEL		REL VEL		MERID VEL		TANG VEL		WHEEL SPEED	
	IN	OUT	IN	OUT	IN	OUT	IN	OUT	IN	OUT
1	148.0	165.2	148.0	165.2	148.0	165.2	-4.1	-1.3	0.	0.
2	154.4	172.3	154.4	172.3	154.3	172.3	-4.1	0.3	0.	0.
3	157.4	176.3	157.4	176.3	157.3	176.3	-4.1	2.6	0.	0.
4	156.4	176.1	156.4	176.1	156.4	176.1	-1.2	1.7	0.	0.
5	156.2	176.3	156.2	176.3	156.2	176.3	-1.4	2.5	0.	0.
6	155.7	175.7	155.7	175.7	155.6	175.7	4.9	2.2	0.	0.
7	155.1	175.2	155.1	175.2	155.1	175.2	2.8	1.9	0.	0.
8	151.3	170.0	151.3	170.0	151.2	170.0	5.5	-1.4	0.	0.
9	148.3	166.0	148.3	166.0	148.1	166.0	7.4	-0.1	0.	0.
10	144.4	159.3	144.4	159.3	144.3	159.3	5.9	1.7	0.	0.
11	142.2	152.9	142.2	152.9	142.1	152.9	4.5	0.9	0.	0.

RP	ABS MACH NO		REL MACH NO		MERID MACH NO		MERID PEAK SS	
	IN	OUT	IN	OUT	IN	OUT	VEL R	MACH NO
1	0.443	0.496	0.443	0.496	0.443	0.496	1.117	0.443
2	0.463	0.519	0.463	0.519	0.463	0.519	1.117	0.463
3	0.472	0.531	0.472	0.531	0.472	0.531	1.121	0.472
4	0.470	0.531	0.470	0.531	0.470	0.531	1.126	0.470
5	0.469	0.532	0.469	0.532	0.469	0.532	1.129	0.469
6	0.468	0.530	0.468	0.530	0.467	0.530	1.129	0.468
7	0.466	0.528	0.466	0.528	0.466	0.528	1.129	0.466
8	0.454	0.512	0.454	0.512	0.454	0.512	1.124	0.454
9	0.445	0.500	0.445	0.500	0.444	0.500	1.121	0.445
10	0.432	0.478	0.432	0.478	0.432	0.478	1.104	0.432
11	0.425	0.458	0.425	0.458	0.425	0.458	1.076	0.425

RP	PERCENT	INCIDENCE		DEV	D-FACT	EFF	LOSS COEFF		LOSS PARAM	
	SPAN	MEAN	SS				TOT	PROF	TOT	PROF
1	5.00	-1.6	-13.6	-0.4	-0.107	0.	0.087	0.087	0.044	0.044
2	10.00	-1.5	-13.5	0.1	-0.103	0.	0.044	0.044	0.022	0.022
3	20.00	-1.5	-13.5	0.8	-0.101	0.	0.036	0.036	0.017	0.017
4	30.00	-0.4	-12.4	0.6	-0.118	0.	0.031	0.031	0.013	0.013
5	38.00	-0.5	-12.5	0.8	-0.118	0.	0.029	0.029	0.012	0.012
6	46.00	1.8	-10.2	0.7	-0.122	0.	0.030	0.030	0.012	0.012
7	50.00	1.0	-11.0	0.6	-0.127	0.	0.032	0.032	0.012	0.012
8	70.00	2.1	-9.9	-0.5	-0.109	0.	0.052	0.052	0.017	0.017
9	80.00	2.8	-9.2	-0.0	-0.105	0.	0.068	0.068	0.020	0.020
10	90.00	2.3	-9.7	0.6	-0.096	0.	0.098	0.098	0.025	0.025
11	95.00	1.8	-10.2	0.3	-0.070	0.	0.169	0.169	0.040	0.040

TABLE VII. - Continued.

(n) Reading 884

RP	RADI I		ABS BETAM		REL BETAM		TOTAL TEMP		TOTAL PRESS	
	IN	OUT	IN	OUT	IN	OUT	IN	RATIO	IN	RATIO
1	25.072	24.971	-1.5	-0.6	-1.5	-0.6	289.1	1.003	10.02	0.990
2	24.412	24.354	-1.4	-0.0	-1.4	-0.0	288.7	1.003	10.14	0.994
3	23.058	23.096	-0.9	0.6	-0.9	0.6	288.6	1.003	10.14	0.996
4	21.659	21.806	-0.1	0.5	-0.1	0.5	288.1	1.003	10.14	0.996
5	20.508	20.752	-0.3	0.7	-0.3	0.7	288.0	1.003	10.14	0.996
6	19.334	19.682	-0.0	0.8	-0.0	0.8	287.9	1.003	10.14	0.995
7	18.738	19.139	0.2	0.8	0.2	0.8	287.8	1.003	10.14	0.995
8	15.624	16.350	2.3	-0.1	2.3	-0.1	287.6	1.003	10.15	0.992
9	13.960	14.889	2.6	0.1	2.6	0.1	287.7	1.002	10.14	0.990
10	12.192	13.365	2.0	0.4	2.0	0.4	287.9	1.002	10.14	0.985
11	11.255	12.573	2.2	0.7	2.2	0.7	288.4	1.001	10.14	0.981

RP	ABS VEL		REL VEL		MERID VEL		TANG VEL		WHEEL SPEED	
	IN	OUT	IN	OUT	IN	OUT	IN	OUT	IN	OUT
1	151.6	170.4	151.6	170.4	151.5	170.4	-4.0	-1.6	0.	0.
2	158.5	177.3	158.5	177.3	158.4	177.3	-5.8	-0.1	0.	0.
3	161.8	181.5	161.8	181.5	161.8	181.5	-2.6	2.0	0.	0.
4	160.8	181.2	160.8	181.2	160.8	181.2	-0.3	1.5	0.	0.
5	160.7	181.2	160.7	181.2	160.7	181.1	-0.9	2.3	0.	0.
6	159.8	180.5	159.8	180.5	159.8	180.5	-0.1	2.6	0.	0.
7	159.1	179.9	159.1	179.9	159.1	179.9	0.5	2.4	0.	0.
8	154.9	174.5	154.9	174.5	154.7	174.5	6.2	-0.3	0.	0.
9	151.8	170.1	151.8	170.1	151.7	170.1	6.9	0.4	0.	0.
10	147.7	163.5	147.7	163.5	147.6	163.5	5.1	1.1	0.	0.
11	145.1	158.6	145.1	158.6	145.0	158.6	5.5	2.0	0.	0.

RP	ABS MACH NO		REL MACH NO		MERID MACH NO		MERID PEAK SS	
	IN	OUT	IN	OUT	IN	OUT	VEL R	MACH NO
1	0.454	0.512	0.454	0.512	0.454	0.512	1.125	0.454
2	0.476	0.534	0.476	0.534	0.475	0.534	1.119	0.476
3	0.486	0.548	0.486	0.548	0.486	0.548	1.122	0.486
4	0.484	0.547	0.484	0.547	0.484	0.547	1.127	0.484
5	0.483	0.547	0.483	0.547	0.483	0.547	1.127	0.483
6	0.481	0.545	0.481	0.545	0.481	0.545	1.129	0.481
7	0.479	0.543	0.479	0.543	0.479	0.543	1.130	0.479
8	0.465	0.527	0.465	0.527	0.465	0.527	1.128	0.465
9	0.456	0.513	0.456	0.513	0.455	0.513	1.122	0.456
10	0.442	0.492	0.442	0.492	0.442	0.492	1.108	0.442
11	0.434	0.476	0.434	0.476	0.434	0.476	1.094	0.434

RP	PERCENT		INCIDENCE		DEV	D-FACT	EFF	LOSS COEFF		LOSS PARAM	
	SPAN	MEAN	SS	TOT				PROF	TOT	PROF	
1	5.00	-1.5	-13.5	-0.6	-0.116	0.	0.076	0.076	0.038	0.038	
2	10.00	-1.4	-13.4	-0.0	-0.107	0.	0.042	0.042	0.021	0.021	
3	20.00	-0.9	-12.9	0.6	-0.109	0.	0.030	0.030	0.014	0.014	
4	30.00	-0.1	-12.1	0.5	-0.122	0.	0.029	0.029	0.013	0.013	
5	38.00	-0.3	-12.3	0.7	-0.119	0.	0.030	0.030	0.013	0.013	
6	46.00	-0.0	-12.0	0.8	-0.123	0.	0.031	0.031	0.012	0.012	
7	50.00	0.2	-11.8	0.8	-0.126	0.	0.032	0.032	0.012	0.012	
8	70.00	2.3	-9.7	-0.1	-0.114	0.	0.059	0.059	0.019	0.019	
9	80.00	2.6	-9.4	0.1	-0.109	0.	0.075	0.075	0.022	0.022	
10	90.00	2.0	-10.0	0.4	-0.101	0.	0.119	0.119	0.030	0.030	
11	95.00	2.2	-9.8	0.7	-0.088	0.	0.155	0.155	0.036	0.036	

TABLE VII. - Continued.

(o) Reading 895

RP	RADII		ABS BETAM		REL BETAM		TOTAL TEMP		TOTAL PRESS	
	IN	OUT	IN	OUT	IN	OUT	IN	RATIO	IN	RATIO
1	25.072	24.971	-1.8	-0.5	-1.8	-0.5	289.0	1.003	10.03	0.989
2	24.412	24.354	-1.8	-0.3	-1.8	-0.3	288.8	1.003	10.14	0.994
3	23.058	23.096	-0.9	0.3	-0.9	0.3	288.3	1.004	10.14	0.995
4	21.659	21.806	0.1	0.4	0.1	0.4	288.1	1.003	10.14	0.996
5	20.508	20.752	0.2	0.6	0.2	0.6	287.9	1.003	10.14	0.996
6	19.334	19.682	0.0	0.7	0.0	0.7	287.9	1.003	10.14	0.995
7	18.738	19.139	1.2	0.8	1.2	0.8	287.9	1.003	10.14	0.995
8	15.624	16.350	2.5	-0.3	2.5	-0.3	287.8	1.003	10.14	0.992
9	13.960	14.889	2.6	0.5	2.6	0.5	287.8	1.002	10.14	0.989
10	12.192	13.365	3.0	0.7	3.0	0.7	288.0	1.002	10.14	0.983
11	11.255	12.573	1.7	0.6	1.7	0.6	288.5	1.001	10.14	0.977

RP	ABS VEL		REL VEL		MERID VEL		TANG VEL		WHEEL SPEED	
	IN	OUT	IN	OUT	IN	OUT	IN	OUT	IN	OUT
1	154.9	174.4	154.9	174.4	154.9	174.4	-5.0	-1.6	0.	0.
2	161.4	181.2	161.4	181.2	161.3	181.2	-5.1	-0.8	0.	0.
3	164.3	185.1	164.3	185.1	164.3	185.1	-2.5	1.0	0.	0.
4	163.4	185.0	163.4	185.0	163.4	185.0	0.4	1.2	0.	0.
5	163.2	184.9	163.2	184.9	163.2	184.9	0.7	1.9	0.	0.
6	162.4	184.1	162.4	184.1	162.4	184.0	0.1	2.2	0.	0.
7	161.9	183.6	161.9	183.6	161.9	183.5	3.5	2.7	0.	0.
8	157.8	178.1	157.8	178.1	157.7	178.1	6.8	-1.0	0.	0.
9	154.6	173.4	154.6	173.4	154.4	173.4	7.1	1.6	0.	0.
10	150.6	166.0	150.6	166.0	150.3	165.9	7.9	2.1	0.	0.
11	148.1	160.4	148.1	160.4	148.1	160.4	4.3	1.5	0.	0.

RP	ABS MACH NO		REL MACH NO		MERID MACH NO		MERID PEAK SS	
	IN	OUT	IN	OUT	IN	OUT	VEL R	MACH NO
1	0.464	0.525	0.464	0.525	0.464	0.525	1.126	0.464
2	0.485	0.547	0.485	0.547	0.484	0.547	1.124	0.485
3	0.494	0.560	0.494	0.560	0.494	0.560	1.127	0.494
4	0.492	0.560	0.492	0.560	0.492	0.560	1.132	0.492
5	0.491	0.559	0.491	0.559	0.491	0.559	1.133	0.491
6	0.489	0.557	0.489	0.557	0.489	0.557	1.133	0.489
7	0.487	0.555	0.487	0.555	0.487	0.555	1.134	0.487
8	0.474	0.538	0.474	0.538	0.474	0.538	1.130	0.474
9	0.464	0.523	0.464	0.523	0.464	0.523	1.123	0.464
10	0.451	0.499	0.451	0.499	0.451	0.499	1.104	0.451
11	0.444	0.482	0.444	0.482	0.443	0.482	1.083	0.444

RP	PERCENT SPAN	INCIDENCE		DEV	D-FACT	EFF	LOSS COEFF		LOSS PARAM	
		MEAN	SS				TOT	PROF	TOT	PROF
1	5.00	-1.8	-13.8	-0.5	-0.115	0.	0.078	0.078	0.039	0.039
2	10.00	-1.8	-13.8	-0.3	-0.110	0.	0.042	0.042	0.021	0.021
3	20.00	-0.9	-12.9	0.3	-0.117	0.	0.031	0.031	0.014	0.014
4	30.00	0.1	-11.9	0.4	-0.130	0.	0.025	0.025	0.011	0.011
5	38.00	0.2	-11.8	0.6	-0.130	0.	0.028	0.028	0.012	0.012
6	46.00	0.0	-12.0	0.7	-0.128	0.	0.032	0.032	0.012	0.012
7	50.00	1.2	-10.8	0.8	-0.132	0.	0.033	0.033	0.013	0.013
8	70.00	2.5	-9.5	-0.3	-0.113	0.	0.058	0.058	0.019	0.019
9	80.00	2.6	-9.4	0.5	-0.112	0.	0.078	0.078	0.022	0.022
10	90.00	3.0	-9.0	0.7	-0.093	0.	0.130	0.130	0.033	0.033
11	95.00	1.6	-10.4	0.6	-0.079	0.	0.180	0.180	0.042	0.042

TABLE VII. - Continued.

(p) Reading 916

RP	RADII		ABS BETAM		REL BETAM		TOTAL TEMP		TOTAL PRESS	
	IN	OUT	IN	OUT	IN	OUT	IN	RATIO	IN	RATIO
1	25.072	24.971	-2.3	-0.7	-2.3	-0.7	289.2	1.002	10.04	0.992
2	24.412	24.354	-2.0	0.9	-2.0	0.9	288.8	1.002	10.14	0.994
3	23.058	23.096	-0.5	1.6	-0.5	1.6	288.6	1.003	10.14	0.993
4	21.659	21.806	-0.5	0.8	-0.5	0.8	288.0	1.003	10.14	0.997
5	20.508	20.752	0.0	0.8	0.0	0.8	288.0	1.002	10.14	0.997
6	19.334	19.682	0.7	0.5	0.7	0.5	287.9	1.002	10.14	0.997
7	18.738	19.139	0.2	0.2	0.2	0.2	287.9	1.002	10.14	0.997
8	15.624	16.350	2.7	-1.3	2.7	-1.3	287.6	1.001	10.14	0.995
9	13.960	14.889	2.2	-0.5	2.2	-0.5	287.8	1.001	10.14	0.995
10	12.192	13.365	3.0	-0.3	3.0	-0.3	287.8	1.001	10.14	0.993
11	11.255	12.573	2.4	-0.2	2.4	-0.2	287.9	1.001	10.14	0.989

RP	ABS VEL		REL VEL		MERID VEL		TANG VEL		WHEEL SPEED	
	IN	OUT	IN	OUT	IN	OUT	IN	OUT	IN	OUT
1	134.0	147.5	134.0	147.5	133.8	147.5	-5.5	-1.7	0.	0.
2	140.2	153.9	140.2	153.9	140.1	153.9	-4.8	2.3	0.	0.
3	143.0	157.4	143.0	157.4	143.0	157.4	-1.2	4.4	0.	0.
4	142.2	157.8	142.2	157.8	142.1	157.8	-1.1	2.1	0.	0.
5	142.0	158.2	142.0	158.2	142.0	158.2	0.1	2.2	0.	0.
6	141.2	157.6	141.2	157.6	141.2	157.6	1.8	1.3	0.	0.
7	140.6	157.2	140.6	157.2	140.6	157.2	0.4	0.6	0.	0.
8	137.0	153.2	137.0	153.2	136.8	153.1	6.4	-3.4	0.	0.
9	134.3	150.2	134.3	150.2	134.2	150.2	5.2	-1.4	0.	0.
10	130.8	144.7	130.8	144.7	130.7	144.7	6.8	-0.7	0.	0.
11	128.7	140.3	128.7	140.3	128.6	140.3	5.5	-0.5	0.	0.

RP	ABS MACH NO		REL MACH NO		MERID MACH NO		MERID PEAK SS	
	IN	OUT	IN	OUT	IN	OUT	VEL R	MACH NO
1	0.399	0.441	0.399	0.441	0.399	0.441	1.102	0.399
2	0.418	0.461	0.418	0.461	0.418	0.461	1.099	0.418
3	0.428	0.472	0.428	0.472	0.428	0.471	1.100	0.428
4	0.425	0.473	0.425	0.473	0.425	0.473	1.110	0.425
5	0.425	0.475	0.425	0.475	0.425	0.475	1.114	0.425
6	0.422	0.473	0.422	0.473	0.422	0.473	1.116	0.422
7	0.421	0.472	0.421	0.472	0.421	0.472	1.118	0.421
8	0.410	0.460	0.410	0.460	0.409	0.460	1.119	0.410
9	0.401	0.450	0.401	0.450	0.401	0.450	1.119	0.401
10	0.391	0.433	0.391	0.433	0.390	0.433	1.107	0.391
11	0.384	0.419	0.384	0.419	0.383	0.419	1.091	0.384

RP	PERCENT SPAN		INCIDENCE MEAN SS		DEV	D-FACT	EFF	LOSS COEFF		LOSS PARAM	
	IN	OUT	IN	OUT				TOT	PROF	TOT	PROF
1	5.00	-2.3	-14.3	-0.7	-0.087	0.	0.081	0.081	0.041	0.041	
2	10.00	-2.0	-14.0	0.9	-0.073	0.	0.049	0.049	0.024	0.024	
3	20.00	-0.5	-12.5	1.6	-0.082	0.	0.058	0.058	0.027	0.027	
4	30.00	-0.5	-12.5	0.8	-0.100	0.	0.029	0.029	0.013	0.013	
5	38.00	0.0	-12.0	0.8	-0.108	0.	0.029	0.029	0.012	0.012	
6	46.00	0.7	-11.3	0.5	-0.115	0.	0.029	0.029	0.011	0.011	
7	50.00	0.2	-11.8	0.2	-0.117	0.	0.028	0.028	0.011	0.011	
8	70.00	2.7	-9.3	-1.3	-0.096	0.	0.044	0.044	0.014	0.014	
9	80.00	2.2	-9.8	-0.5	-0.104	0.	0.048	0.048	0.014	0.014	
10	90.00	2.9	-9.1	-0.3	-0.092	0.	0.071	0.071	0.018	0.018	
11	95.00	2.4	-9.6	-0.2	-0.080	0.	0.111	0.111	0.026	0.026	

TABLE VII. - Continued.

(q) Reading 927

RP	RADII		ABS BETAM		REL BETAM		TOTAL TEMP		TOTAL PRESS	
	IN	OUT	IN	OUT	IN	OUT	IN	RATIO	IN	RATIO
1	25.072	24.971	-2.4	-0.8	-2.4	-0.8	289.2	1.003	10.03	0.989
2	24.412	24.354	-1.0	0.5	-1.0	0.5	288.6	1.003	10.14	0.994
3	23.058	23.096	-0.8	1.4	-0.8	1.4	288.5	1.003	10.14	0.994
4	21.659	21.806	0.1	0.7	0.1	0.7	287.9	1.003	10.14	0.996
5	20.508	20.752	-0.6	0.7	-0.6	0.7	288.0	1.003	10.14	0.996
6	19.334	19.682	1.1	0.5	1.1	0.5	287.8	1.003	10.14	0.996
7	18.738	19.139	0.5	0.2	0.5	0.2	287.9	1.003	10.14	0.996
8	15.624	16.350	1.6	-1.3	1.6	-1.3	287.8	1.002	10.14	0.994
9	13.960	14.889	2.1	-0.7	2.1	-0.7	287.9	1.002	10.14	0.994
10	12.192	13.365	2.9	-0.4	2.9	-0.4	288.1	1.002	10.14	0.993
11	11.255	12.573	2.0	-0.4	2.0	-0.4	288.3	1.001	10.14	0.988

RP	ABS VEL		REL VEL		MERID VEL		TANG VEL		WHEEL SPEED	
	IN	OUT	IN	OUT	IN	OUT	IN	OUT	IN	OUT
1	139.7	154.0	139.7	154.0	139.5	153.9	-5.8	-2.2	0.	0.
2	146.4	161.8	146.4	161.8	146.4	161.8	-2.6	1.3	0.	0.
3	149.6	165.9	149.6	165.9	149.6	165.8	-2.1	4.0	0.	0.
4	148.6	166.0	148.6	166.0	148.6	166.0	0.1	2.1	0.	0.
5	148.5	166.2	148.5	166.2	148.5	166.2	-1.5	2.2	0.	0.
6	147.9	165.8	147.9	165.8	147.9	165.8	2.8	1.5	0.	0.
7	147.5	165.4	147.5	165.4	147.5	165.4	1.2	0.5	0.	0.
8	143.9	161.2	143.9	161.2	143.8	161.2	4.1	-3.7	0.	0.
9	140.9	158.2	140.9	158.2	140.8	158.2	5.1	-1.8	0.	0.
10	137.4	152.6	137.4	152.6	137.2	152.6	6.9	-1.0	0.	0.
11	135.1	147.3	135.1	147.3	135.0	147.3	4.7	-1.1	0.	0.

RP	ABS MACH NO		REL MACH NO		MERID MACH NO		MERID PEAK SS	
	IN	OUT	IN	OUT	IN	OUT	VEL R	MACH NO
1	0.417	0.460	0.417	0.460	0.416	0.460	1.103	0.417
2	0.438	0.485	0.438	0.485	0.438	0.485	1.105	0.438
3	0.448	0.498	0.448	0.498	0.448	0.498	1.109	0.448
4	0.445	0.499	0.445	0.499	0.445	0.499	1.117	0.445
5	0.445	0.500	0.445	0.500	0.445	0.500	1.119	0.445
6	0.443	0.499	0.443	0.499	0.443	0.499	1.121	0.443
7	0.442	0.498	0.442	0.498	0.442	0.498	1.122	0.442
8	0.431	0.485	0.431	0.485	0.431	0.484	1.121	0.431
9	0.422	0.475	0.422	0.475	0.421	0.475	1.123	0.422
10	0.410	0.457	0.410	0.457	0.410	0.457	1.112	0.410
11	0.403	0.441	0.403	0.441	0.403	0.441	1.091	0.403

RP	PERCENT		INCIDENCE		DEV	D-FACT	EFF	LOSS COEFF		LOSS PARAM	
	SPAN	MEAN	SS	TOT				PROF	TOT	PROF	
1	5.00	-2.4	-14.4	-0.8	-0.089	0.	0.098	0.098	0.050	0.050	
2	10.00	-1.0	-13.0	0.5	-0.092	0.	0.046	0.046	0.023	0.023	
3	20.00	-0.8	-12.8	1.4	-0.090	0.	0.050	0.050	0.023	0.023	
4	30.00	0.1	-11.9	0.7	-0.111	0.	0.028	0.028	0.012	0.012	
5	38.00	-0.6	-12.6	0.7	-0.109	0.	0.030	0.030	0.012	0.012	
6	46.00	1.1	-10.9	0.5	-0.118	0.	0.028	0.028	0.011	0.011	
7	50.00	0.5	-11.5	0.2	-0.120	0.	0.028	0.028	0.011	0.011	
8	70.00	1.6	-10.4	-1.3	-0.103	0.	0.049	0.049	0.016	0.016	
9	80.00	2.1	-9.9	-0.7	-0.109	0.	0.049	0.049	0.014	0.014	
10	90.00	2.8	-9.2	-0.4	-0.097	0.	0.064	0.064	0.016	0.016	
11	95.00	2.0	-10.0	-0.4	-0.080	0.	0.117	0.117	0.028	0.028	

TABLE VII. - Continued.

(r) Reading 938

RP	RADI I		ABS BETAM		REL BETAM		TOTAL TEMP		TOTAL PRESS	
	IN	OUT	IN	OUT	IN	OUT	IN	RATIO	IN	RATIO
1	25.072	24.971	-2.4	-1.0	-2.4	-1.0	289.0	1.003	10.03	0.989
2	24.412	24.354	-2.0	0.2	-2.0	0.2	288.8	1.003	10.14	0.994
3	23.058	23.096	-0.8	1.1	-0.8	1.1	288.4	1.003	10.14	0.994
4	21.659	21.806	-0.5	0.6	-0.5	0.6	288.0	1.003	10.14	0.996
5	20.508	20.752	-0.2	0.8	-0.2	0.8	288.0	1.003	10.14	0.996
6	19.334	19.682	0.4	0.6	0.4	0.6	287.8	1.003	10.14	0.997
7	18.738	19.139	1.4	0.5	1.4	0.5	287.8	1.003	10.14	0.996
8	15.624	16.350	1.1	-1.1	1.1	-1.1	287.7	1.003	10.14	0.993
9	13.960	14.889	3.2	-0.6	3.2	-0.6	287.8	1.002	10.14	0.992
10	12.192	13.365	2.4	-0.7	2.4	-0.7	288.0	1.002	10.14	0.989
11	11.255	12.573	1.9	-0.9	1.9	-0.9	288.5	1.001	10.14	0.983

RP	ABS VEL		REL VEL		MERID VEL		TANG VEL		WHEEL SPEED	
	IN	OUT	IN	OUT	IN	OUT	IN	OUT	IN	OUT
1	146.0	162.0	146.0	162.0	145.9	161.9	-6.0	-2.8	0.	0.
2	152.2	169.5	152.2	169.5	152.2	169.5	-5.3	0.6	0.	0.
3	155.1	173.3	155.1	173.3	155.1	173.3	-2.1	3.2	0.	0.
4	154.3	173.2	154.3	173.2	154.3	173.2	-1.4	1.8	0.	0.
5	154.1	173.4	154.1	173.4	154.1	173.4	-0.5	2.5	0.	0.
6	153.4	173.0	153.4	173.0	153.4	173.0	1.1	1.7	0.	0.
7	152.9	172.5	152.9	172.5	152.9	172.5	3.7	1.4	0.	0.
8	149.1	167.5	149.1	167.5	149.1	167.5	2.8	-3.3	0.	0.
9	146.3	164.0	146.3	164.0	146.0	164.0	8.2	-1.7	0.	0.
10	142.4	157.4	142.4	157.4	142.2	157.4	6.0	-1.9	0.	0.
11	140.1	151.9	140.1	151.9	140.0	151.9	4.7	-2.3	0.	0.

RP	ABS MACH NO		REL MACH NO		MERID MACH NO		MERID PEAK SS	
	IN	OUT	IN	OUT	IN	OUT	VEL R	MACH NO
1	0.436	0.485	0.436	0.485	0.436	0.485	1.110	0.436
2	0.456	0.509	0.456	0.509	0.456	0.509	1.114	0.456
3	0.465	0.522	0.465	0.522	0.465	0.522	1.117	0.465
4	0.463	0.522	0.463	0.522	0.463	0.522	1.123	0.463
5	0.463	0.523	0.463	0.523	0.463	0.522	1.125	0.463
6	0.460	0.521	0.460	0.521	0.460	0.521	1.128	0.460
7	0.459	0.520	0.459	0.520	0.459	0.520	1.128	0.459
8	0.447	0.504	0.447	0.504	0.447	0.504	1.123	0.447
9	0.438	0.493	0.438	0.493	0.438	0.493	1.123	0.438
10	0.426	0.472	0.426	0.472	0.426	0.472	1.106	0.426
11	0.419	0.455	0.419	0.455	0.418	0.455	1.085	0.419

RP	PERCENT	INCIDENCE		DEV	D-FACT	EFF	LOSS COEFF		LOSS PARAM	
	SPAN	MEAN	SS				TOT	PROF	TOT	PROF
1	5.00	-2.4	-14.4	-1.0	-0.098	0.	0.094	0.094	0.047	0.047
2	10.00	-2.0	-14.0	0.2	-0.094	0.	0.043	0.043	0.021	0.021
3	20.00	-0.8	-12.8	1.1	-0.102	0.	0.042	0.042	0.020	0.020
4	30.00	-0.5	-12.5	0.6	-0.113	0.	0.032	0.032	0.014	0.014
5	38.00	-0.2	-12.2	0.8	-0.117	0.	0.031	0.031	0.013	0.013
6	46.00	0.4	-11.6	0.6	-0.126	0.	0.025	0.025	0.010	0.010
7	50.00	1.4	-10.6	0.5	-0.122	0.	0.028	0.028	0.011	0.011
8	70.00	1.1	-10.9	-1.1	-0.110	0.	0.052	0.052	0.017	0.017
9	80.00	3.2	-8.8	-0.6	-0.102	0.	0.061	0.061	0.018	0.018
10	90.00	2.4	-9.6	-0.7	-0.092	0.	0.096	0.096	0.024	0.024
11	95.00	1.9	-10.1	-0.9	-0.073	0.	0.150	0.150	0.035	0.035

TABLE VII. - Continued.

(s) Reading 950

RP	RADII		ABS BETAM		REL BETAM		TOTAL TEMP		TOTAL PRESS	
	IN	OUT	IN	OUT	IN	OUT	IN	RATIO	IN	RATIO
1	25.072	24.971	-2.5	-1.0	-2.5	-1.0	289.2	1.003	10.01	0.990
2	24.412	24.354	-2.2	-0.1	-2.2	-0.1	288.7	1.003	10.14	0.994
3	23.058	23.096	-1.2	0.6	-1.2	0.6	288.4	1.003	10.14	0.994
4	21.659	21.806	-0.5	0.4	-0.5	0.4	288.1	1.003	10.14	0.996
5	20.508	20.752	0.3	0.6	0.3	0.6	288.0	1.003	10.14	0.996
6	19.334	19.682	0.7	0.6	0.7	0.6	287.9	1.003	10.14	0.996
7	18.738	19.139	1.7	0.5	1.7	0.5	287.9	1.003	10.14	0.995
8	15.624	16.350	2.1	-1.1	2.1	-1.1	287.7	1.003	10.14	0.991
9	13.960	14.889	3.0	-0.6	3.0	-0.6	287.7	1.002	10.14	0.990
10	12.192	13.365	2.2	-0.9	2.2	-0.9	288.0	1.002	10.14	0.986
11	11.255	12.573	2.3	-1.3	2.3	-1.3	288.3	1.001	10.14	0.980

RP	ABS VEL		REL VEL		MERID VEL		TANG VEL		WHEEL SPEED	
	IN	OUT	IN	OUT	IN	OUT	IN	OUT	IN	OUT
1	149.0	168.1	149.0	168.1	148.8	168.1	-6.4	-3.1	0.	0.
2	156.5	175.2	156.5	175.2	156.4	175.2	-6.0	-0.2	0.	0.
3	160.1	179.3	160.1	179.3	160.1	179.3	-3.2	1.9	0.	0.
4	159.2	179.3	159.2	179.3	159.2	179.3	-1.3	1.3	0.	0.
5	159.0	179.6	159.0	179.6	159.0	179.6	0.8	1.8	0.	0.
6	158.2	178.7	158.2	178.7	158.2	178.7	2.0	1.8	0.	0.
7	157.8	178.2	157.8	178.2	157.8	178.2	4.6	1.4	0.	0.
8	154.1	173.1	154.1	173.1	154.0	173.0	5.6	-3.4	0.	0.
9	151.1	169.2	151.1	169.2	150.9	169.2	7.8	-1.9	0.	0.
10	146.9	162.3	146.9	162.3	146.8	162.2	5.7	-2.4	0.	0.
11	144.3	156.4	144.3	156.4	144.2	156.3	5.9	-3.5	0.	0.

RP	ABS MACH NO		REL MACH NO		MERID MACH NO		MERID PEAK SS	
	IN	OUT	IN	OUT	IN	OUT	VEL R	MACH NO
1	0.445	0.505	0.445	0.505	0.445	0.505	1.129	0.445
2	0.470	0.528	0.470	0.528	0.469	0.528	1.120	0.470
3	0.481	0.541	0.481	0.541	0.481	0.541	1.120	0.481
4	0.478	0.541	0.478	0.541	0.478	0.541	1.126	0.478
5	0.478	0.542	0.478	0.542	0.478	0.542	1.130	0.478
6	0.475	0.540	0.475	0.540	0.475	0.539	1.130	0.475
7	0.474	0.538	0.474	0.538	0.474	0.538	1.129	0.474
8	0.463	0.522	0.463	0.522	0.462	0.522	1.124	0.463
9	0.453	0.510	0.453	0.510	0.453	0.509	1.121	0.453
10	0.440	0.488	0.440	0.488	0.440	0.488	1.105	0.440
11	0.432	0.469	0.432	0.469	0.431	0.469	1.084	0.432

RP	PERCENT	INCIDENCE		DEV	D-FACT	EFF	LOSS COEFF		LOSS PARAM	
	SPAN	MEAN	SS				TOT	PROF	TOT	PROF
1	5.00	-2.5	-14.5	-1.0	-0.117	0.	0.076	0.076	0.039	0.039
2	10.00	-2.2	-14.2	-0.1	-0.101	0.	0.044	0.044	0.022	0.022
3	20.00	-1.2	-13.2	0.6	-0.105	0.	0.038	0.038	0.017	0.017
4	30.00	-0.5	-12.5	0.4	-0.119	0.	0.031	0.031	0.014	0.014
5	38.00	0.3	-11.7	0.6	-0.127	0.	0.028	0.028	0.011	0.011
6	46.00	0.7	-11.3	0.6	-0.129	0.	0.029	0.029	0.011	0.011
7	50.00	1.7	-10.3	0.5	-0.121	0.	0.033	0.033	0.012	0.012
8	70.00	2.1	-9.9	-1.1	-0.105	0.	0.063	0.063	0.020	0.020
9	80.00	2.9	-9.1	-0.6	-0.102	0.	0.075	0.075	0.022	0.022
10	90.00	2.2	-9.8	-0.9	-0.091	0.	0.110	0.110	0.028	0.028
11	95.00	2.3	-9.7	-1.3	-0.069	0.	0.163	0.163	0.038	0.038

TABLE VII. - Concluded.

(t) Reading 963

RP	RAD II		ABS BETAM		REL BETAM		TOTAL TEMP		TOTAL PRESS	
	IN	OUT	IN	OUT	IN	OUT	IN	RATIO	IN	RATIO
1	25.072	24.971	-2.3	-1.2	-2.3	-1.2	289.2	1.003	10.03	0.986
2	24.412	24.354	-1.5	-0.5	-1.5	-0.5	288.7	1.003	10.14	0.994
3	23.058	23.096	-0.7	0.3	-0.7	0.3	288.3	1.004	10.14	0.995
4	21.659	21.806	-0.3	0.2	-0.3	0.2	288.0	1.003	10.14	0.996
5	20.508	20.752	1.1	0.3	1.1	0.3	287.9	1.003	10.14	0.996
6	19.334	19.682	0.4	0.3	0.4	0.3	287.9	1.003	10.14	0.995
7	18.738	19.139	1.5	0.3	1.5	0.3	287.9	1.003	10.14	0.995
8	15.624	16.350	1.5	-1.1	1.5	-1.1	288.0	1.002	10.14	0.991
9	13.960	14.889	2.9	-0.5	2.9	-0.5	287.7	1.002	10.14	0.988
10	12.192	13.365	2.5	-0.6	2.5	-0.6	287.9	1.002	10.14	0.985
11	11.255	12.573	1.8	-1.4	1.8	-1.4	288.2	1.002	10.14	0.978

RP	ABS VEL		REL VEL		MERID VEL		TANG VEL		WHEEL SPEED	
	IN	OUT	IN	OUT	IN	OUT	IN	OUT	IN	OUT
1	154.9	172.6	154.9	172.6	154.7	172.6	-6.2	-3.5	0.	0.
2	161.1	180.8	161.1	180.8	161.0	180.8	-4.3	-1.5	0.	0.
3	164.2	185.2	164.2	185.2	164.2	185.2	-2.1	0.8	0.	0.
4	163.3	184.8	163.3	184.8	163.3	184.8	-1.0	0.7	0.	0.
5	162.9	184.6	162.9	184.6	162.9	184.6	3.1	1.1	0.	0.
6	162.1	183.8	162.1	183.8	162.1	183.8	1.0	0.9	0.	0.
7	161.6	183.3	161.6	183.3	161.5	183.3	4.1	1.1	0.	0.
8	157.0	177.3	157.0	177.3	157.0	177.3	4.0	-3.5	0.	0.
9	153.9	173.1	153.9	173.1	153.7	173.1	7.9	-1.4	0.	0.
10	149.6	166.3	149.6	166.3	149.5	166.3	6.5	-1.7	0.	0.
11	147.2	159.8	147.2	159.8	147.1	159.8	4.6	-3.8	0.	0.

RP	ABS MACH NO		REL MACH NO		MERID MACH NO		MERID PEAK SS	
	IN	OUT	IN	OUT	IN	OUT	VEL R	MACH NO
1	0.464	0.519	0.464	0.519	0.464	0.519	1.115	0.464
2	0.484	0.545	0.484	0.545	0.484	0.545	1.123	0.484
3	0.494	0.560	0.494	0.560	0.494	0.560	1.128	0.494
4	0.491	0.559	0.491	0.559	0.491	0.559	1.132	0.491
5	0.490	0.558	0.490	0.558	0.490	0.558	1.133	0.490
6	0.488	0.556	0.488	0.556	0.488	0.556	1.134	0.488
7	0.486	0.554	0.486	0.554	0.486	0.554	1.135	0.486
8	0.472	0.535	0.472	0.535	0.472	0.535	1.129	0.472
9	0.462	0.522	0.462	0.522	0.462	0.522	1.126	0.462
10	0.449	0.500	0.449	0.500	0.448	0.500	1.112	0.449
11	0.441	0.480	0.441	0.480	0.441	0.480	1.086	0.441

RP	PERCENT SPAN	INCIDENCE		DEV	D-FACT	EFF	LOSS COEFF		LOSS PARAM	
		MEAN	SS				TOT	PROF	TOT	PROF
1	5.00	-2.3	-14.3	-1.2	-0.106	0.	0.103	0.103	0.052	0.052
2	10.00	-1.5	-13.5	-0.5	-0.114	0.	0.039	0.039	0.019	0.019
3	20.00	-0.7	-12.7	0.2	-0.120	0.	0.032	0.032	0.015	0.015
4	30.00	-0.3	-12.3	0.2	-0.127	0.	0.029	0.029	0.013	0.013
5	38.00	1.1	-10.9	0.3	-0.128	0.	0.027	0.027	0.011	0.011
6	46.00	0.4	-11.6	0.3	-0.134	0.	0.032	0.032	0.013	0.013
7	50.00	1.5	-10.5	0.3	-0.128	0.	0.033	0.033	0.013	0.013
8	70.00	1.5	-10.5	-1.1	-0.114	0.	0.066	0.066	0.021	0.021
9	80.00	2.9	-9.1	-0.5	-0.107	0.	0.091	0.091	0.026	0.026
10	90.00	2.5	-9.5	-0.6	-0.098	0.	0.112	0.112	0.029	0.029
11	95.00	1.8	-10.2	-1.4	-0.072	0.	0.173	0.173	0.041	0.041

TABLE VIII. - ROTOR BLADE-ELEMENT DATA

(a) Reading 724

RP	RADI I		ABS BETAM		REL BETAM		TOTAL TEMP		TOTAL PRESS	
	IN	OUT	IN	OUT	IN	OUT	IN	RATIO	IN	RATIO
1	24.795	24.656	-0.5	32.2	64.6	62.2	290.3	1.152	9.92	1.429
2	24.216	24.092	-0.7	28.0	63.1	62.6	289.9	1.126	10.07	1.388
3	23.040	22.962	-0.5	27.9	61.1	61.3	289.5	1.119	10.08	1.395
4	21.841	21.831	-0.5	29.5	60.2	58.8	289.2	1.122	10.08	1.395
5	20.866	20.927	-0.2	33.2	59.9	57.8	289.1	1.127	9.86	1.428
6	19.878	20.023	-1.2	31.9	58.6	59.0	289.0	1.113	10.05	1.320
7	19.378	19.571	-0.2	33.0	57.6	56.4	288.9	1.115	10.04	1.349
8	16.812	17.310	-1.3	33.0	55.7	43.4	288.3	1.125	9.90	1.469
9	15.471	16.180	-0.9	34.3	53.9	37.1	288.2	1.126	9.91	1.493
10	14.079	15.049	-0.6	35.7	52.0	30.5	288.2	1.125	9.89	1.519
11	13.360	14.483	1.7	39.2	49.8	24.1	288.8	1.130	9.89	1.540

RP	ABS VEL		REL VEL		MERID VEL		TANG VEL		WHEEL SPEED	
	IN	OUT	IN	OUT	IN	OUT	IN	OUT	IN	OUT
1	199.9	195.2	466.6	354.1	199.9	165.1	-1.9	104.1	419.7	417.3
2	208.5	186.7	460.9	358.8	208.5	164.9	-2.6	87.7	408.4	406.3
3	215.7	186.8	447.0	343.4	215.7	165.1	-1.7	87.4	389.8	388.5
4	212.1	190.9	427.1	321.1	212.1	166.2	-1.7	94.1	369.0	368.9
5	205.4	189.1	409.5	296.6	205.4	158.2	-0.8	103.6	353.4	354.5
6	208.6	174.8	399.9	288.1	208.5	148.4	-4.5	92.3	336.7	339.1
7	208.7	183.1	389.2	277.8	208.7	153.6	-0.7	99.7	327.8	331.1
8	197.4	219.6	350.6	253.6	197.3	184.2	-4.4	119.5	285.3	293.8
9	193.4	230.9	328.4	239.2	193.4	190.9	-3.2	130.0	262.2	274.2
10	188.1	240.4	305.5	226.4	188.1	195.1	-2.0	140.4	238.7	255.2
11	186.6	251.0	289.3	213.0	186.6	194.4	5.4	158.7	226.5	245.6

RP	ABS MACH NO		REL MACH NO		MERID MACH NO		MERID PEAK SS	
	IN	OUT	IN	OUT	IN	OUT	VEL R	MACH NO
1	0.606	0.548	1.415	0.995	0.606	0.464	0.826	1.527
2	0.635	0.530	1.403	1.018	0.635	0.468	0.791	1.502
3	0.659	0.532	1.366	0.978	0.659	0.470	0.765	1.474
4	0.648	0.544	1.304	0.915	0.648	0.474	0.784	1.461
5	0.626	0.538	1.247	0.843	0.626	0.450	0.770	1.462
6	0.636	0.498	1.220	0.821	0.636	0.423	0.712	1.458
7	0.637	0.523	1.188	0.793	0.637	0.439	0.736	1.431
8	0.600	0.632	1.066	0.730	0.600	0.530	0.934	1.451
9	0.587	0.667	0.997	0.691	0.587	0.552	0.987	1.448
10	0.570	0.698	0.926	0.657	0.570	0.566	1.037	1.371
11	0.565	0.729	0.876	0.619	0.565	0.565	1.042	1.272

RP	PERCENT SPAN	INCIDENCE		DEV	D-FACT	EFF	LOSS COEFF		LOSS PARAM	
		MEAN	SS				TOT	PROF	TOT	PROF
1	5.00	3.0	0.1	4.3	0.320	0.709	0.183	0.095	0.030	0.015
2	10.00	2.5	-0.7	5.6	0.288	0.776	0.123	0.042	0.019	0.007
3	20.00	2.5	-1.2	6.1	0.297	0.837	0.088	0.018	0.014	0.003
4	30.00	3.6	-0.7	5.9	0.318	0.819	0.104	0.046	0.017	0.007
5	38.00	4.7	0.1	7.0	0.351	0.841	0.101	0.050	0.016	0.008
6	46.00	4.9	-0.1	10.9	0.348	0.731	0.155	0.109	0.023	0.016
7	50.00	4.7	-0.6	10.0	0.358	0.779	0.135	0.096	0.021	0.015
8	70.00	6.8	0.7	7.8	0.363	0.927	0.056	0.029	0.010	0.005
9	80.00	7.0	0.6	9.4	0.363	0.963	0.031	0.011	0.006	0.002
10	90.00	7.2	0.6	12.9	0.355	1.013	-0.012	-0.020	-0.002	-0.003
11	95.00	6.2	-0.4	12.4	0.369	1.010	-0.011	-0.012	-0.002	-0.002

TABLE VIII. - Continued.

(b) Reading 736

RP	RADI I		ABS BETAM		REL BETAM		TOTAL TEMP		TOTAL PRESS	
	IN	OUT	IN	OUT	IN	OUT	IN	RATIO	IN	RATIO
1	24.795	24.656	-0.6	43.2	65.5	62.5	290.0	1.196	9.92	1.587
2	24.216	24.092	-0.6	37.8	63.9	61.8	289.8	1.168	10.07	1.556
3	23.040	22.962	-0.4	35.8	62.1	59.5	289.4	1.154	10.08	1.565
4	21.841	21.831	-0.2	38.4	60.7	57.2	289.1	1.157	10.09	1.559
5	20.866	20.927	-0.2	41.8	59.6	57.0	289.0	1.157	10.08	1.534
6	19.878	20.023	-0.0	41.5	58.6	57.0	289.0	1.142	10.06	1.475
7	19.378	19.571	-0.0	39.7	58.1	54.6	288.9	1.138	10.05	1.501
8	16.812	17.310	-1.3	37.3	56.1	42.8	288.3	1.135	9.92	1.560
9	15.471	16.180	-1.0	38.7	54.5	39.0	288.2	1.130	9.92	1.541
10	14.079	15.049	-0.7	40.5	52.5	33.2	288.3	1.127	9.90	1.527
11	13.360	14.483	1.6	44.7	50.3	24.3	288.8	1.136	9.91	1.572

RP	ABS VEL		REL VEL		MERID VEL		TANG VEL		WHEEL SPEED	
	IN	OUT	IN	OUT	IN	OUT	IN	OUT	IN	OUT
1	190.9	198.4	459.5	313.1	190.9	144.6	-2.1	135.8	415.9	413.5
2	199.6	193.5	454.3	323.6	199.6	152.9	-2.1	118.7	406.0	403.9
3	205.6	196.1	438.7	313.4	205.6	159.0	-1.3	114.8	386.3	384.9
4	206.0	199.2	420.9	288.0	205.9	156.0	-0.9	123.9	366.1	366.0
5	205.7	193.6	406.4	264.7	205.7	144.3	-0.7	129.0	349.8	350.8
6	204.0	185.2	391.1	254.4	204.0	138.6	-0.0	122.8	333.6	336.1
7	202.5	190.9	383.2	253.2	202.5	146.8	-0.2	122.0	325.1	328.3
8	192.5	216.0	344.8	234.2	192.5	171.8	-4.3	130.9	281.7	290.1
9	188.0	216.1	323.3	217.0	187.9	168.7	-3.4	135.1	259.7	271.6
10	183.1	220.3	300.7	200.1	183.1	167.5	-2.2	143.1	236.2	252.5
11	181.9	237.5	284.7	185.3	181.8	168.9	5.2	167.0	224.4	243.3

RP	ABS MACH NO		REL MACH NO		MERID MACH NO		MERID PEAK SS	
	IN	OUT	IN	OUT	IN	OUT	VEL R	MACH NO
1	0.577	0.547	1.390	0.864	0.577	0.399	0.757	1.530
2	0.606	0.540	1.379	0.903	0.606	0.427	0.766	1.506
3	0.626	0.551	1.336	0.881	0.626	0.447	0.773	1.476
4	0.627	0.560	1.282	0.810	0.627	0.439	0.757	1.457
5	0.627	0.544	1.238	0.743	0.627	0.405	0.702	1.444
6	0.621	0.522	1.191	0.717	0.621	0.391	0.680	1.434
7	0.617	0.540	1.166	0.717	0.617	0.416	0.725	1.431
8	0.584	0.618	1.047	0.670	0.584	0.492	0.893	1.452
9	0.570	0.620	0.980	0.623	0.570	0.484	0.897	1.441
10	0.554	0.634	0.910	0.576	0.554	0.482	0.915	1.362
11	0.550	0.684	0.861	0.534	0.549	0.487	0.929	1.264

RP	PERCENT SPAN	INCIDENCE		DEV	D-FACT	EFF	LOSS COEFF		LOSS PARAM	
		MEAN	SS				TOT	PROF	TOT	PROF
1	5.00	3.8	0.9	4.6	0.424	0.721	0.219	0.134	0.036	0.022
2	10.00	3.3	0.1	4.8	0.379	0.803	0.140	0.062	0.023	0.010
3	20.00	3.4	-0.3	4.3	0.372	0.887	0.079	0.013	0.013	0.002
4	30.00	4.0	-0.2	4.2	0.408	0.860	0.103	0.048	0.017	0.008
5	38.00	4.5	-0.2	6.2	0.444	0.830	0.130	0.083	0.021	0.013
6	46.00	4.9	-0.1	8.9	0.439	0.826	0.128	0.089	0.020	0.014
7	50.00	5.2	-0.0	8.1	0.428	0.889	0.082	0.046	0.013	0.007
8	70.00	7.1	1.0	7.2	0.416	1.001	-0.000	-0.026	-0.000	-0.005
9	80.00	7.5	1.1	11.3	0.426	1.014	-0.012	-0.030	-0.002	-0.005
10	90.00	7.7	1.1	15.6	0.434	1.016	-0.016	-0.022	-0.003	-0.004
11	95.00	6.7	0.0	12.7	0.462	1.016	-0.019	-0.019	-0.003	-0.003

TABLE VIII. - Continued.

(c) Reading 749

RP	RADI I		ABS BETAM		REL BETAM		TOTAL TEMP		TOTAL PRESS	
	IN	OUT	IN	OUT	IN	OUT	IN	RATIO	IN	RATIO
1	24.795	24.656	-0.6	51.1	66.8	59.5	289.8	1.251	9.93	1.768
2	24.216	24.092	-0.5	44.7	65.4	59.5	289.6	1.210	10.07	1.706
3	23.040	22.962	-0.0	41.4	63.5	57.8	289.3	1.183	10.08	1.681
4	21.841	21.831	-0.0	42.7	62.2	55.8	288.9	1.179	10.09	1.675
5	20.866	20.927	0.2	44.6	61.1	54.6	288.9	1.175	10.09	1.645
6	19.878	20.023	0.1	44.7	60.1	53.6	288.8	1.164	10.07	1.619
7	19.378	19.571	-0.1	44.5	59.6	52.4	288.8	1.161	10.06	1.618
8	16.812	17.310	-1.4	45.6	57.4	45.6	288.5	1.151	9.99	1.612
9	15.471	16.180	-1.0	47.6	55.7	44.6	288.4	1.137	9.98	1.551
10	14.079	15.049	-0.3	49.0	53.8	38.7	288.4	1.131	9.95	1.527
11	13.360	14.483	1.9	52.1	51.8	24.2	288.9	1.147	9.95	1.622

RP	ABS VEL		REL VEL		MERID VEL		TANG VEL		WHEEL SPEED	
	IN	OUT	IN	OUT	IN	OUT	IN	OUT	IN	OUT
1	179.3	224.5	455.0	277.8	179.3	140.9	-1.7	174.7	416.5	414.1
2	187.5	211.8	449.8	237.2	187.5	150.7	-1.7	148.9	407.1	405.0
3	193.1	208.3	433.1	293.6	193.1	156.3	-0.1	137.7	387.6	386.3
4	193.7	208.7	415.3	272.9	193.7	153.4	-0.0	141.5	367.3	367.2
5	193.7	206.4	400.3	253.8	193.7	147.0	0.5	145.0	350.9	351.9
6	192.3	201.8	385.4	241.9	192.3	143.5	0.3	141.9	334.3	336.7
7	191.2	202.6	378.2	236.8	191.2	144.6	-0.2	141.9	326.2	329.4
8	185.9	203.8	340.9	203.7	183.8	142.7	-4.4	145.6	282.7	291.0
9	179.5	193.7	318.6	183.7	179.5	130.7	-3.1	143.0	260.1	272.0
10	174.2	197.6	294.7	166.0	174.2	129.5	-1.0	149.2	236.7	253.0
11	172.5	228.6	278.5	153.9	172.4	140.4	5.9	180.5	224.6	243.4

RP	ABS MACH NO		REL MACH NO		MERID MACH NO		MERID PEAK SS	
	IN	OUT	IN	OUT	IN	OUT	VEL R	MACH NO
1	0.540	0.610	1.372	0.754	0.540	0.383	0.786	1.558
2	0.567	0.584	1.360	0.819	0.567	0.415	0.804	1.536
3	0.585	0.580	1.313	0.818	0.585	0.435	0.809	1.505
4	0.588	0.583	1.260	0.762	0.588	0.429	0.792	1.488
5	0.588	0.577	1.215	0.710	0.588	0.411	0.759	1.473
6	0.583	0.566	1.169	0.679	0.583	0.403	0.746	1.467
7	0.580	0.570	1.147	0.666	0.580	0.406	0.756	1.469
8	0.556	0.577	1.032	0.576	0.556	0.404	0.776	1.489
9	0.542	0.550	0.963	0.521	0.542	0.371	0.729	1.457
10	0.526	0.563	0.889	0.473	0.526	0.369	0.743	1.369
11	0.520	0.653	0.839	0.439	0.519	0.401	0.814	1.273

RP	PERCENT		INCIDENCE		DEV	D-FACT	EFF	LOSS COEFF		LOSS PARAM	
	SPAN	MEAN	SS	TOT				PROF	TOT	PROF	
1	5.00	5.2	2.3	1.6	0.525	0.705	0.283	0.195	0.050	0.035	
2	10.00	4.7	1.5	2.5	0.454	0.786	0.184	0.102	0.032	0.018	
3	20.00	4.9	1.2	2.7	0.426	0.874	0.102	0.034	0.018	0.006	
4	30.00	5.5	1.3	2.8	0.449	0.888	0.094	0.037	0.016	0.006	
5	38.00	5.9	1.2	3.9	0.473	0.873	0.109	0.060	0.019	0.010	
6	46.00	6.4	1.4	5.6	0.477	0.898	0.087	0.045	0.015	0.008	
7	50.00	6.8	1.5	5.9	0.478	0.915	0.074	0.034	0.012	0.006	
8	70.00	8.4	2.3	10.0	0.509	0.972	0.027	-0.002	0.005	-0.000	
9	80.00	8.8	2.4	17.0	0.527	0.975	0.025	0.006	0.004	0.001	
10	90.00	9.0	2.4	21.2	0.542	0.981	0.020	0.014	0.003	0.002	
11	95.00	8.1	1.5	12.5	0.572	1.009	-0.011	-0.011	-0.002	-0.002	

TABLE VIII. - Continued.

(d) Reading 760

RP	RAD II		ABS BETAM		REL BETAM		TOTAL TEMP		TOTAL PRESS	
	IN	OUT	IN	OUT	IN	OUT	IN	RATIO	IN	RATIO
1	24.795	24.656	-0.6	52.6	67.5	58.6	289.8	1.264	9.95	1.810
2	24.216	24.092	0.0	46.4	66.0	58.3	289.5	1.222	10.06	1.754
3	23.040	22.962	0.2	42.1	64.3	56.6	289.2	1.191	10.08	1.723
4	21.841	21.831	0.0	43.2	63.0	54.8	288.9	1.185	10.09	1.709
5	20.866	20.927	0.2	45.7	61.9	54.0	288.9	1.181	10.09	1.669
6	19.878	20.023	-0.0	47.0	60.9	53.3	288.8	1.174	10.08	1.637
7	19.378	19.571	-0.2	47.4	60.5	52.4	288.8	1.171	10.07	1.627
8	16.812	17.310	-1.6	48.0	58.1	48.4	288.4	1.150	10.01	1.591
9	15.471	16.180	-0.9	50.1	56.3	46.2	288.4	1.139	10.02	1.545
10	14.079	15.049	-0.5	51.3	54.6	39.2	288.4	1.135	9.97	1.539
11	13.360	14.483	2.3	55.0	52.5	23.5	288.9	1.152	9.97	1.634

RP	ABS VEL		REL VEL		MERID VEL		TANG VEL		WHEEL SPEED	
	IN	OUT	IN	OUT	IN	OUT	IN	OUT	IN	OUT
1	173.6	231.6	453.1	269.8	173.6	140.6	-1.8	184.1	416.8	414.4
2	180.9	220.0	445.0	288.4	180.9	151.7	0.1	159.3	406.7	404.6
3	186.3	214.8	429.1	289.6	186.3	159.5	0.5	143.9	387.1	385.7
4	187.1	213.6	412.2	270.2	187.1	155.6	0.1	146.3	367.4	367.2
5	187.1	209.9	397.0	249.4	187.1	146.6	0.8	150.2	351.0	352.0
6	185.9	204.5	382.8	233.6	185.9	139.4	-0.1	149.5	334.5	336.9
7	184.9	203.5	375.1	226.0	184.9	137.8	-0.7	149.7	325.7	328.9
8	178.8	194.5	338.4	195.9	178.8	130.1	-4.8	144.5	282.5	290.9
9	175.4	189.6	316.2	175.7	175.3	121.6	-2.9	145.4	260.2	272.1
10	169.7	196.4	292.7	158.5	169.7	122.8	-1.4	153.3	237.1	253.5
11	167.5	228.2	274.9	142.6	167.4	130.8	6.8	187.0	224.9	243.8

RP	ABS MACH NO		REL MACH NO		MERID MACH NO		MERID PEAK SS	
	IN	OUT	IN	OUT	IN	OUT	VEL R	MACH NO
1	0.522	0.627	1.363	0.730	0.522	0.380	0.810	1.573
2	0.546	0.605	1.343	0.793	0.546	0.417	0.839	1.542
3	0.563	0.598	1.298	0.806	0.563	0.444	0.856	1.516
4	0.566	0.596	1.248	0.754	0.566	0.434	0.832	1.504
5	0.566	0.586	1.202	0.696	0.566	0.409	0.783	1.490
6	0.563	0.572	1.159	0.653	0.563	0.390	0.750	1.489
7	0.559	0.570	1.135	0.633	0.559	0.386	0.745	1.488
8	0.540	0.549	1.022	0.553	0.540	0.367	0.728	1.511
9	0.529	0.537	0.954	0.497	0.529	0.344	0.694	1.463
10	0.511	0.558	0.882	0.450	0.511	0.349	0.724	1.382
11	0.504	0.650	0.827	0.406	0.503	0.373	0.781	1.275

RP	PERCENT		INCIDENCE		DEV	D-FACT	EFF	LOSS COEFF		LOSS PARAM	
	SPAN	MEAN	SS	TOT				PROF	TOT	PROF	
1	5.00	5.9	2.9	0.7	0.548	0.699	0.301	0.211	0.055	0.039	
2	10.00	5.4	2.2	1.2	0.474	0.785	0.195	0.115	0.035	0.021	
3	20.00	5.7	1.9	1.4	0.434	0.883	0.100	0.032	0.018	0.006	
4	30.00	6.3	2.1	1.9	0.455	0.895	0.092	0.033	0.016	0.006	
5	38.00	6.7	2.1	3.3	0.484	0.870	0.116	0.066	0.020	0.012	
6	46.00	7.3	2.2	5.3	0.501	0.871	0.116	0.072	0.020	0.012	
7	50.00	7.6	2.3	6.0	0.509	0.874	0.115	0.074	0.019	0.012	
8	70.00	9.1	3.1	12.8	0.529	0.947	0.051	0.019	0.008	0.003	
9	80.00	9.4	3.0	18.5	0.550	0.951	0.048	0.030	0.007	0.005	
10	90.00	9.8	3.2	21.7	0.568	0.970	0.032	0.026	0.005	0.004	
11	95.00	8.9	2.2	11.8	0.611	0.994	0.008	0.008	0.001	0.001	

TABLE VIII. - Continued.

(e) Reading 771

RP	RADI I		ABS BETAM		REL BETAM		TOTAL TEMP		TOTAL PRESS	
	IN	OUT	IN	OUT	IN	OUT	IN	RATIO	IN	RATIO
1	24.795	24.656	-0.4	57.2	68.7	59.7	289.7	1.282	9.97	1.860
2	24.216	24.092	-0.2	48.7	67.4	58.2	289.5	1.234	10.07	1.810
3	23.040	22.962	0.7	44.0	65.6	56.2	289.2	1.199	10.08	1.772
4	21.841	21.831	0.2	45.5	64.4	55.3	288.9	1.191	10.10	1.736
5	20.866	20.927	0.2	49.7	63.3	55.3	288.8	1.191	10.09	1.687
6	19.878	20.023	-0.2	53.0	62.4	55.6	288.8	1.187	10.08	1.634
7	19.378	19.571	-0.5	52.6	61.9	54.6	288.7	1.181	10.08	1.623
8	16.812	17.310	-1.7	48.7	59.4	48.7	288.4	1.151	10.04	1.564
9	15.471	16.180	-0.9	50.4	57.6	43.5	288.3	1.146	10.05	1.555
10	14.079	15.049	-0.5	50.8	55.8	35.0	288.3	1.142	10.01	1.555
11	13.360	14.483	2.3	54.7	53.9	19.3	288.7	1.159	10.00	1.654

RP	ABS VEL		REL VEL		MERID VEL		TANG VEL		WHEEL SPEED	
	IN	OUT	IN	OUT	IN	OUT	IN	OUT	IN	OUT
1	163.1	234.4	448.8	251.8	163.1	126.9	-1.1	197.1	417.0	414.6
2	170.0	223.1	441.7	279.3	170.0	147.3	-0.7	167.6	407.0	404.9
3	175.0	218.2	423.2	282.1	175.0	156.9	2.1	151.6	387.4	386.1
4	175.8	212.9	406.5	261.9	175.8	149.3	0.7	151.8	367.2	367.0
5	175.8	207.3	391.6	235.3	175.8	133.9	0.7	158.2	350.6	351.6
6	174.9	200.8	377.8	213.7	174.9	120.8	-0.6	160.3	334.2	336.6
7	174.4	199.4	370.7	209.0	174.4	121.0	-1.6	158.4	325.5	328.8
8	170.2	193.5	334.2	193.6	170.1	127.7	-5.1	145.4	282.5	290.9
9	166.8	197.8	311.2	173.6	166.8	126.0	-2.7	152.5	260.0	271.9
10	161.6	207.7	287.6	160.0	161.6	131.1	-1.4	161.0	236.5	252.8
11	159.1	239.1	269.9	146.4	159.0	138.2	6.5	195.1	224.6	243.4

RP	ABS MACH NO		REL MACH NO		MERID MACH NO		MERID PEAK SS	
	IN	OUT	IN	OUT	IN	OUT	VEL R	MACH NO
1	0.489	0.631	1.346	0.677	0.489	0.341	0.778	1.598
2	0.511	0.611	1.328	0.764	0.511	0.403	0.867	1.574
3	0.527	0.606	1.275	0.783	0.527	0.436	0.896	1.539
4	0.530	0.593	1.226	0.729	0.530	0.415	0.849	1.531
5	0.530	0.576	1.181	0.654	0.530	0.372	0.762	1.522
6	0.528	0.558	1.139	0.594	0.528	0.336	0.691	1.524
7	0.526	0.555	1.118	0.582	0.526	0.337	0.694	1.526
8	0.513	0.546	1.007	0.546	0.513	0.360	0.751	1.551
9	0.502	0.560	0.937	0.491	0.502	0.357	0.756	1.477
10	0.486	0.591	0.865	0.455	0.486	0.373	0.811	1.391
11	0.478	0.682	0.810	0.418	0.477	0.394	0.869	1.288

RP	PERCENT	INCIDENCE		DEV	D-FACT	EFF	LOSS COEFF		LOSS PARAM	
	SPAN	MEAN	SS				TOT	PROF	TOT	PROF
1	5.00	7.1	4.2	1.8	0.593	0.688	0.330	0.237	0.058	0.042
2	10.00	6.8	3.6	1.1	0.498	0.788	0.203	0.118	0.037	0.021
3	20.00	7.0	3.2	1.0	0.449	0.894	0.096	0.026	0.017	0.005
4	30.00	7.7	3.4	2.3	0.471	0.893	0.097	0.036	0.017	0.006
5	38.00	8.2	3.5	4.6	0.519	0.844	0.147	0.094	0.025	0.016
6	46.00	8.8	3.7	7.5	0.555	0.807	0.187	0.139	0.030	0.022
7	50.00	9.1	3.8	8.2	0.556	0.818	0.176	0.131	0.028	0.021
8	70.00	10.4	4.3	13.1	0.530	0.902	0.096	0.060	0.015	0.009
9	80.00	10.7	4.3	15.8	0.555	0.923	0.081	0.063	0.013	0.010
10	90.00	11.0	4.4	17.5	0.561	0.948	0.061	0.056	0.010	0.009
11	95.00	10.3	3.6	7.7	0.596	0.974	0.038	0.037	0.007	0.007

TABLE VIII. - Continued.

(f) Reading 785

RP	RADII		ABS BETAM		REL BETAM		TOTAL TEMP		TOTAL PRESS	
	IN	OUT	IN	OUT	IN	OUT	IN	RATIO	IN	RATIO
1	24.795	24.656	0.3	62.9	70.2	67.8	289.7	1.259	9.95	1.676
2	24.216	24.092	1.7	58.2	68.2	64.6	290.1	1.233	10.08	1.644
3	23.040	22.962	2.7	49.7	66.6	59.2	290.0	1.200	10.08	1.679
4	21.841	21.831	2.4	46.2	65.4	55.6	288.9	1.183	10.10	1.670
5	20.866	20.927	2.0	47.5	64.3	53.2	288.5	1.183	10.11	1.665
6	19.878	20.023	1.6	48.7	63.4	51.5	288.3	1.180	10.11	1.637
7	19.378	19.571	1.3	48.8	62.9	50.2	288.2	1.177	10.12	1.628
8	16.812	17.310	-0.1	48.6	60.1	44.0	287.6	1.156	10.10	1.589
9	15.471	16.180	0.9	50.9	58.6	40.0	287.7	1.149	10.09	1.555
10	14.079	15.049	1.3	51.5	56.8	30.7	287.8	1.147	10.09	1.568
11	13.360	14.483	0.9	52.9	56.2	19.6	288.1	1.159	10.06	1.629

RP	ABS VEL		REL VEL		MERID VEL		TANG VEL		WHEEL SPEED	
	IN	OUT	IN	OUT	IN	OUT	IN	OUT	IN	OUT
1	149.8	206.1	441.3	248.6	149.8	93.9	0.9	183.4	416.0	413.6
2	158.7	203.6	427.1	250.3	158.6	107.4	4.6	173.0	401.2	399.1
3	164.1	208.3	412.9	263.3	163.9	134.6	7.6	158.9	386.6	385.2
4	164.7	211.0	394.9	258.5	164.6	146.0	6.9	152.3	365.9	365.7
5	165.5	213.7	381.8	241.3	165.4	144.4	5.8	157.6	349.9	350.9
6	165.1	213.1	368.6	225.5	165.0	140.5	4.6	160.2	334.2	336.6
7	164.8	212.9	361.3	218.9	164.8	140.2	3.6	160.3	325.2	328.4
8	160.6	206.6	321.9	190.0	160.6	136.7	-0.3	154.9	278.6	286.8
9	157.4	208.1	301.7	171.5	157.4	131.3	2.6	161.5	260.0	271.9
10	152.8	219.8	278.9	159.1	152.8	136.9	3.5	171.9	236.8	253.1
11	148.8	240.4	267.4	153.9	148.8	144.9	2.4	191.7	224.6	243.5

RP	ABS MACH NO		REL MACH NO		MERID MACH NO		MERID PEAK SS	
	IN	OUT	IN	OUT	IN	OUT	VEL R	MACH NO
1	0.448	0.555	1.319	0.669	0.448	0.253	0.626	1.622
2	0.475	0.553	1.279	0.680	0.475	0.292	0.677	1.556
3	0.492	0.575	1.238	0.727	0.492	0.372	0.821	1.541
4	0.495	0.589	1.187	0.722	0.495	0.408	0.887	1.532
5	0.498	0.597	1.148	0.674	0.497	0.404	0.873	1.531
6	0.497	0.597	1.109	0.631	0.497	0.393	0.851	1.536
7	0.496	0.597	1.087	0.614	0.496	0.393	0.851	1.537
8	0.483	0.584	0.968	0.537	0.483	0.387	0.851	1.523
9	0.473	0.591	0.907	0.487	0.473	0.373	0.834	1.459
10	0.459	0.627	0.837	0.454	0.459	0.390	0.896	1.374
11	0.446	0.687	0.801	0.440	0.446	0.414	0.974	1.337

RP	PERCENT		INCIDENCE		DEV	D-FACT	EFF	LOSS COEFF		LOSS PARAM	
	SPAN	MEAN	SS	TOT				PROF	TOT	PROF	
1	5.00	8.6	5.6	9.9	0.581	0.615	0.383	0.289	0.051	0.038	
2	10.00	7.6	4.4	7.6	0.549	0.655	0.332	0.259	0.049	0.038	
3	20.00	8.0	4.2	4.1	0.482	0.799	0.184	0.120	0.031	0.020	
4	30.00	8.7	4.4	2.6	0.459	0.862	0.126	0.070	0.022	0.012	
5	38.00	9.2	4.5	2.5	0.486	0.854	0.138	0.088	0.025	0.016	
6	46.00	9.8	4.7	3.4	0.508	0.839	0.156	0.110	0.028	0.019	
7	50.00	10.0	4.7	3.7	0.515	0.842	0.156	0.112	0.028	0.020	
8	70.00	11.1	5.0	8.4	0.527	0.908	0.097	0.070	0.017	0.012	
9	80.00	11.6	5.2	12.4	0.551	0.902	0.110	0.096	0.019	0.016	
10	90.00	12.0	5.4	13.1	0.555	0.932	0.086	0.082	0.015	0.014	
11	95.00	12.6	5.9	8.0	0.565	0.941	0.085	0.084	0.015	0.015	

TABLE VIII. - Continued.

(g) Reading 796

RP	RADII		ABS BETAM		REL BETAM		TOTAL TEMP		TOTAL PRESS	
	IN	OUT	IN	OUT	IN	OUT	IN	RATIO	IN	RATIO
1	24.795	24.656	-0.1	44.3	65.9	62.8	290.1	1.197	9.90	1.558
2	24.216	24.092	0.7	37.8	63.8	61.2	289.7	1.163	10.08	1.534
3	23.040	22.962	1.3	36.6	61.9	59.2	289.3	1.151	10.10	1.532
4	21.841	21.831	1.4	38.9	60.5	56.9	288.9	1.153	10.10	1.526
5	20.866	20.927	1.6	42.7	59.3	56.4	288.9	1.155	10.10	1.512
6	19.878	20.023	1.4	42.5	58.2	56.8	288.8	1.140	10.10	1.427
7	19.378	19.571	1.4	40.4	57.6	53.6	288.7	1.138	10.10	1.463
8	16.812	17.310	0.6	37.0	55.0	39.7	288.5	1.137	10.06	1.526
9	15.471	16.180	1.1	38.3	53.1	34.6	288.4	1.133	10.05	1.522
10	14.079	15.049	1.2	40.8	51.4	26.4	288.6	1.137	10.04	1.541
11	13.360	14.483	0.1	43.2	51.7	20.0	288.8	1.147	9.94	1.573

RP	ABS VEL		REL VEL		MERID VEL		TANG VEL		WHEEL SPEED	
	IN	OUT	IN	OUT	IN	OUT	IN	OUT	IN	OUT
1	187.3	198.4	458.0	311.1	187.3	142.0	-0.3	138.5	417.6	415.3
2	197.6	195.8	447.0	321.1	197.6	154.7	2.5	120.0	403.4	401.4
3	204.6	198.7	434.2	311.9	204.5	159.5	4.8	118.5	387.8	386.5
4	204.8	201.5	416.3	287.6	204.8	156.9	5.1	126.4	367.6	367.5
5	205.0	197.6	401.7	262.3	204.9	145.3	5.8	133.9	351.2	352.2
6	204.0	186.9	387.4	251.9	204.0	137.9	5.1	126.1	334.5	336.9
7	203.4	195.7	379.8	251.4	203.3	149.1	5.1	126.7	325.9	329.1
8	196.4	230.1	342.4	239.0	196.4	183.8	2.2	138.3	282.7	291.0
9	192.5	234.5	320.8	223.6	192.5	184.1	3.6	145.2	260.2	272.1
10	185.5	245.9	297.5	207.8	185.4	186.2	4.0	160.7	236.7	253.0
11	177.2	256.3	285.8	198.6	177.2	186.7	0.3	175.6	224.6	243.5

RP	ABS MACH NO		REL MACH NO		MERID MACH NO		MERID PEAK SS	
	IN	OUT	IN	OUT	IN	OUT	VEL R	MACH NO
1	0.566	0.547	1.383	0.858	0.566	0.391	0.758	1.538
2	0.599	0.548	1.356	0.899	0.599	0.433	0.783	1.478
3	0.623	0.560	1.322	0.879	0.622	0.450	0.780	1.457
4	0.624	0.568	1.268	0.811	0.624	0.442	0.766	1.439
5	0.625	0.556	1.224	0.738	0.624	0.409	0.709	1.422
6	0.622	0.528	1.180	0.711	0.621	0.389	0.676	1.413
7	0.619	0.555	1.157	0.713	0.619	0.423	0.733	1.408
8	0.597	0.661	1.041	0.687	0.597	0.528	0.936	1.412
9	0.584	0.676	0.974	0.645	0.584	0.531	0.957	1.388
10	0.561	0.711	0.901	0.600	0.561	0.538	1.004	1.316
11	0.535	0.740	0.863	0.574	0.535	0.539	1.054	1.307

RP	PERCENT	INCIDENCE		DEV	D-FACT	EFF	LOSS COEFF		LOSS PARAM	
	SPAN	MEAN	SS				TOT	PROF	TOT	PROF
1	5.00	4.3	1.3	4.9	0.427	0.685	0.248	0.162	0.040	0.026
2	10.00	3.2	-0.0	4.2	0.371	0.795	0.145	0.075	0.024	0.012
3	20.00	3.3	-0.5	4.1	0.367	0.859	0.097	0.037	0.016	0.006
4	30.00	3.9	-0.4	4.0	0.400	0.837	0.119	0.069	0.020	0.012
5	38.00	4.2	-0.5	5.6	0.442	0.808	0.147	0.105	0.024	0.017
6	46.00	4.6	-0.5	8.8	0.439	0.761	0.174	0.139	0.027	0.022
7	50.00	4.8	-0.5	7.2	0.427	0.832	0.124	0.093	0.020	0.015
8	70.00	6.0	-0.1	4.1	0.399	0.939	0.052	0.032	0.010	0.006
9	80.00	6.2	-0.2	6.9	0.403	0.958	0.039	0.027	0.007	0.005
10	90.00	6.7	0.1	8.9	0.411	0.960	0.043	0.040	0.008	0.007
11	95.00	8.1	1.4	8.4	0.426	0.939	0.074	0.072	0.013	0.013

TABLE VIII. - Continued.

(h) Reading 808

RP	RADII		ABS BETAM		REL BETAM		TOTAL TEMP		TOTAL PRESS	
	IN	OUT	IN	OUT	IN	OUT	IN	RATIO	IN	RATIO
1	24.795	24.656	0.0	55.7	66.4	65.8	289.9	1.234	9.92	1.644
2	24.216	24.092	1.1	45.0	64.6	60.8	289.6	1.197	10.08	1.657
3	23.040	22.962	1.6	41.1	62.7	58.6	289.3	1.171	10.09	1.614
4	21.841	21.831	1.3	42.8	61.3	56.9	288.9	1.169	10.10	1.601
5	20.866	20.927	1.6	45.4	60.1	55.1	288.8	1.170	10.10	1.599
6	19.878	20.023	1.6	44.4	59.0	54.4	288.7	1.155	10.10	1.539
7	19.378	19.571	1.4	42.4	58.5	51.9	288.7	1.150	10.10	1.563
8	16.812	17.310	0.4	39.7	55.8	39.7	288.4	1.144	10.07	1.571
9	15.471	16.180	0.8	42.3	54.0	33.9	288.4	1.145	10.07	1.569
10	14.079	15.049	1.1	43.4	52.3	28.3	288.6	1.138	10.03	1.538
11	13.360	14.483	0.2	45.8	52.2	20.4	288.8	1.150	9.96	1.586

RP	ABS VEL		REL VEL		MERID VEL		TANG VEL		WHEEL SPEED	
	IN	OUT	IN	OUT	IN	OUT	IN	OUT	IN	OUT
1	181.8	199.6	454.9	274.1	181.8	112.5	0.1	164.9	417.1	414.8
2	191.2	205.2	446.2	297.4	191.2	145.1	3.7	145.1	406.8	404.7
3	197.5	204.0	429.8	295.2	197.4	153.8	5.4	134.0	387.2	385.9
4	198.1	203.3	412.9	272.7	198.0	149.0	4.5	138.2	366.8	366.7
5	198.4	204.5	398.0	251.1	198.3	143.5	5.6	145.7	350.6	351.7
6	197.4	198.5	383.3	243.3	197.3	141.8	5.6	138.9	334.2	336.7
7	196.8	203.8	376.5	243.6	196.8	150.4	4.9	137.5	325.9	329.1
8	190.9	227.3	339.7	227.6	190.9	175.0	1.2	145.1	282.2	290.6
9	187.0	232.4	318.0	206.9	187.0	171.8	2.6	156.5	259.9	271.8
10	180.2	234.7	294.8	193.7	180.2	170.6	3.4	161.2	236.6	253.0
11	173.7	249.5	283.5	185.5	173.7	173.9	0.6	178.9	224.6	243.4

RP	ABS MACH NO		REL MACH NO		MERID MACH NO		MERID PEAK SS	
	IN	OUT	IN	OUT	IN	OUT	VEL R	MACH NO
1	0.548	0.542	1.372	0.744	0.548	0.305	0.619	1.547
2	0.579	0.567	1.351	0.822	0.579	0.401	0.759	1.503
3	0.600	0.571	1.305	0.826	0.599	0.430	0.779	1.467
4	0.602	0.569	1.255	0.764	0.602	0.418	0.753	1.454
5	0.603	0.573	1.210	0.704	0.603	0.402	0.724	1.437
6	0.600	0.559	1.165	0.685	0.600	0.399	0.719	1.428
7	0.598	0.576	1.144	0.689	0.598	0.425	0.764	1.428
8	0.579	0.650	1.031	0.651	0.579	0.500	0.916	1.436
9	0.567	0.666	0.964	0.593	0.566	0.492	0.919	1.402
10	0.545	0.675	0.891	0.557	0.545	0.491	0.947	1.328
11	0.524	0.718	0.855	0.533	0.524	0.500	1.001	1.310

RP	PERCENT SPAN		INCIDENCE MEAN SS		DEV	D-FACT	EFF	LOSS COEFF		LOSS PARAM	
	SPAN	MEAN	SS	TOT				PROF	TOT	PROF	
1	5.00	4.8	1.9	7.8	0.524	0.652	0.313	0.227	0.045	0.033	
2	10.00	4.0	0.8	3.8	0.442	0.789	0.174	0.101	0.029	0.017	
3	20.00	4.0	0.3	3.4	0.411	0.859	0.109	0.049	0.019	0.008	
4	30.00	4.7	0.4	3.9	0.440	0.851	0.119	0.068	0.020	0.012	
5	38.00	5.0	0.3	4.4	0.474	0.846	0.129	0.087	0.022	0.015	
6	46.00	5.4	0.3	6.3	0.464	0.848	0.123	0.088	0.020	0.015	
7	50.00	5.6	0.4	5.4	0.451	0.905	0.078	0.045	0.013	0.008	
8	70.00	6.8	0.8	4.2	0.433	0.954	0.043	0.021	0.008	0.004	
9	80.00	7.1	0.7	6.2	0.459	0.950	0.051	0.038	0.009	0.007	
10	90.00	7.5	0.9	10.8	0.454	0.950	0.054	0.051	0.010	0.009	
11	95.00	8.6	1.9	8.7	0.470	0.941	0.074	0.073	0.013	0.013	

TABLE VIII. - Continued.

(i) Reading 819

RP	RADII		ABS BETAM		REL BETAM		TOTAL TEMP		TOTAL PRESS	
	IN	OUT	IN	OUT	IN	OUT	IN	RATIO	IN	RATIO
1	24.795	24.656	0.2	57.5	67.5	64.8	289.9	1.251	9.91	1.708
2	24.216	24.092	1.1	47.6	65.7	60.3	289.4	1.213	10.09	1.704
3	23.040	22.962	1.8	42.9	63.4	57.3	289.4	1.182	10.09	1.663
4	21.841	21.831	1.6	43.6	62.1	55.2	288.7	1.177	10.11	1.661
5	20.866	20.927	1.7	45.1	61.2	53.7	288.8	1.175	10.11	1.651
6	19.878	20.023	1.5	45.3	60.2	52.7	288.6	1.165	10.11	1.609
7	19.378	19.571	1.4	44.7	59.6	51.2	288.6	1.161	10.11	1.609
8	16.812	17.310	0.2	44.9	56.9	42.5	288.4	1.152	10.08	1.602
9	15.471	16.180	1.0	47.3	55.0	38.8	288.4	1.144	10.08	1.563
10	14.079	15.049	1.0	48.1	53.4	33.0	288.6	1.138	10.06	1.534
11	13.360	14.483	0.1	50.4	53.2	22.0	288.8	1.154	9.99	1.607

RP	ABS VEL		REL VEL		MERID VEL		TANG VEL		WHEEL SPEED	
	IN	OUT	IN	OUT	IN	OUT	IN	OUT	IN	OUT
1	173.1	209.4	451.8	264.0	173.1	112.5	0.5	176.6	417.8	415.4
2	183.0	211.4	444.2	287.9	183.0	142.5	3.6	156.1	408.4	406.3
3	189.3	209.8	422.6	284.7	189.2	153.8	5.8	142.7	383.6	382.3
4	189.9	210.1	405.6	266.4	189.8	152.2	5.2	144.8	363.7	363.5
5	190.3	211.5	395.1	252.0	190.2	149.2	5.6	149.9	351.9	353.0
6	189.6	207.0	381.3	240.1	189.6	145.6	4.9	147.2	335.7	338.2
7	189.3	208.1	373.9	235.9	189.3	147.8	4.6	146.5	327.0	330.3
8	184.2	215.2	337.5	207.0	184.2	152.5	0.7	151.9	283.5	291.8
9	180.6	213.3	314.7	185.5	180.5	144.6	3.2	156.8	261.0	273.0
10	174.4	215.6	292.4	171.8	174.4	144.1	3.0	160.5	237.6	254.0
11	168.4	237.8	281.4	163.4	168.4	151.5	0.2	183.3	225.6	244.6

RP	ABS MACH NO		REL MACH NO		MERID MACH NO		MERID PEAK SS	
	IN	OUT	IN	OUT	IN	OUT	VEL R	MACH NO
1	0.521	0.566	1.359	0.714	0.521	0.304	0.650	1.569
2	0.553	0.582	1.342	0.792	0.553	0.392	0.779	1.529
3	0.573	0.585	1.279	0.794	0.573	0.429	0.812	1.469
4	0.576	0.588	1.230	0.746	0.575	0.426	0.802	1.457
5	0.577	0.593	1.198	0.706	0.577	0.418	0.785	1.464
6	0.575	0.582	1.156	0.675	0.575	0.409	0.768	1.461
7	0.574	0.586	1.133	0.665	0.574	0.417	0.781	1.457
8	0.558	0.611	1.022	0.587	0.557	0.433	0.828	1.471
9	0.546	0.607	0.951	0.528	0.546	0.411	0.801	1.417
10	0.526	0.616	0.882	0.491	0.526	0.412	0.826	1.346
11	0.507	0.679	0.847	0.467	0.507	0.433	0.899	1.327

RP	PERCENT	INCIDENCE		DEV	D-FACT	EFF	LOSS COEFF		LOSS PARAM	
	SPAN	MEAN	SS				TOT	PROF	TOT	PROF
1	5.00	5.9	2.9	6.9	0.552	0.659	0.326	0.237	0.049	0.035
2	10.00	5.1	1.9	3.3	0.469	0.774	0.199	0.121	0.034	0.021
3	20.00	4.8	1.0	2.1	0.432	0.860	0.116	0.060	0.021	0.011
4	30.00	5.4	1.2	2.2	0.450	0.882	0.101	0.053	0.018	0.009
5	38.00	6.1	1.4	2.9	0.471	0.880	0.105	0.060	0.018	0.011
6	46.00	6.6	1.5	4.6	0.476	0.880	0.104	0.065	0.018	0.011
7	50.00	6.7	1.5	4.7	0.475	0.903	0.085	0.049	0.015	0.008
8	70.00	7.9	1.9	7.0	0.496	0.948	0.050	0.024	0.009	0.004
9	80.00	8.1	1.7	11.1	0.521	0.942	0.059	0.046	0.010	0.008
10	90.00	8.6	2.0	15.5	0.524	0.945	0.061	0.057	0.010	0.010
11	95.00	9.6	3.0	10.4	0.548	0.944	0.073	0.071	0.013	0.013

TABLE VIII. - Continued.

(j) Reading 830

RP	RADII		ABS. BETAM		REL BETAM		TOTAL TEMP		TOTAL PRESS	
	IN	OUT	IN	OUT	IN	OUT	IN	RATIO	IN	RATIO
1	24.795	24.656	0.2	58.2	68.5	65.9	289.9	1.246	9.94	1.698
2	24.216	24.092	1.5	49.9	68.8	60.9	289.7	1.218	10.06	1.708
3	23.040	22.962	2.4	44.9	64.9	57.6	289.6	1.189	10.08	1.688
4	21.841	21.831	1.8	44.4	63.7	55.5	288.8	1.180	10.10	1.680
5	20.866	20.927	1.7	46.2	62.6	53.1	288.7	1.181	10.11	1.670
6	19.878	20.023	1.6	47.2	61.5	51.8	288.5	1.174	10.11	1.637
7	19.378	19.571	1.4	47.5	61.0	50.5	288.5	1.172	10.11	1.632
8	16.812	17.310	0.1	48.6	58.4	44.4	288.1	1.157	10.09	1.601
9	15.471	16.180	0.9	50.4	56.5	41.7	288.1	1.145	10.09	1.546
10	14.079	15.049	1.0	50.9	54.8	33.6	288.2	1.141	10.08	1.547
11	13.360	14.483	0.6	52.8	54.4	21.8	288.5	1.156	10.03	1.619

RP	ABS VEL		REL VEL		MERID VEL		TANG VEL		WHEEL SPEED	
	IN	OUT	IN	OUT	IN	OUT	IN	OUT	IN	OUT
1	163.8	204.6	447.8	264.2	163.7	107.9	0.6	173.8	417.4	415.0
2	172.5	210.5	438.0	279.4	172.4	135.7	4.6	160.9	407.2	405.1
3	178.1	212.1	419.5	280.1	177.9	150.3	7.5	149.7	387.4	386.1
4	178.8	211.2	403.6	266.2	178.8	150.9	5.5	147.8	367.3	367.1
5	179.5	213.9	389.5	246.8	179.4	148.0	5.3	154.5	351.0	352.0
6	178.8	210.9	374.7	231.4	178.8	143.2	4.8	154.8	334.2	336.6
7	178.4	211.6	367.9	224.7	178.3	143.1	4.2	155.9	326.0	329.2
8	173.4	208.2	331.3	192.9	173.4	137.8	0.4	156.1	282.7	291.1
9	170.3	203.3	308.8	173.8	170.3	129.7	2.7	156.5	260.3	272.3
10	164.9	211.9	286.3	160.4	164.9	133.6	2.8	164.5	236.9	253.2
11	159.6	234.8	274.4	153.0	159.6	142.1	1.6	187.0	224.8	243.7

RP	ABS MACH NO		REL MACH NO		MERID MACH NO		MERID PEAK SS	
	IN	OUT	IN	OUT	IN	OUT	VEL R	MACH NO
1	0.491	0.553	1.343	0.715	0.491	0.292	0.659	1.596
2	0.519	0.578	1.318	0.767	0.519	0.372	0.787	1.545
3	0.537	0.590	1.265	0.779	0.536	0.418	0.845	1.507
4	0.540	0.590	1.218	0.744	0.540	0.422	0.844	1.502
5	0.542	0.599	1.176	0.690	0.542	0.414	0.825	1.493
6	0.540	0.591	1.132	0.649	0.540	0.402	0.801	1.488
7	0.539	0.594	1.111	0.631	0.539	0.402	0.802	1.490
8	0.523	0.588	1.000	0.545	0.523	0.390	0.795	1.517
9	0.513	0.577	0.931	0.493	0.513	0.368	0.762	1.435
10	0.496	0.604	0.862	0.457	0.496	0.381	0.810	1.359
11	0.479	0.670	0.824	0.436	0.479	0.405	0.890	1.325

RP	PERCENT	INCIDENCE		DEV	D-FACT	EFF	LOSS COEFF		LOSS PARAM	
	SPAN	MEAN	SS				TOT	PROF	TOT	PROF
1	5.00	6.9	4.0	8.0	0.545	0.663	0.322	0.231	0.046	0.033
2	10.00	6.2	3.0	3.9	0.484	0.759	0.219	0.141	0.036	0.024
3	20.00	6.3	2.5	2.4	0.443	0.855	0.125	0.064	0.022	0.011
4	30.00	7.0	2.8	2.5	0.450	0.887	0.099	0.044	0.017	0.008
5	38.00	7.4	2.7	2.4	0.480	0.871	0.118	0.071	0.021	0.013
6	46.00	7.9	2.8	3.7	0.496	0.868	0.123	0.082	0.021	0.014
7	50.00	8.1	2.9	4.0	0.504	0.872	0.121	0.083	0.021	0.015
8	70.00	9.5	3.4	8.8	0.532	0.919	0.082	0.052	0.014	0.009
9	80.00	9.6	3.2	14.1	0.550	0.916	0.088	0.075	0.015	0.012
10	90.00	10.1	3.5	16.1	0.557	0.938	0.072	0.068	0.012	0.011
11	95.00	10.8	4.2	10.1	0.576	0.947	0.073	0.071	0.013	0.013

TABLE VIII. - Continued.

(k) Reading 845

RP	RADII		ABS BETAM		REL BETAM		TOTAL TEMP		TOTAL PRESS	
	IN	OUT	IN	OUT	IN	OUT	IN	RATIO	IN	RATIO
1	24.795	24.656	-0.5	61.9	67.8	72.2	289.7	1.222	9.93	1.558
2	24.216	24.092	0.3	51.2	66.2	64.9	289.6	1.206	10.08	1.588
3	23.040	22.962	1.2	44.6	64.0	59.2	289.5	1.182	10.08	1.606
4	21.841	21.831	0.8	42.2	63.0	56.5	289.0	1.170	10.09	1.610
5	20.866	20.927	0.8	43.6	61.9	53.2	288.7	1.174	10.10	1.634
6	19.878	20.023	0.7	43.3	60.8	52.0	288.7	1.162	10.10	1.583
7	19.378	19.571	0.6	42.2	60.2	50.5	288.6	1.157	10.10	1.589
8	16.812	17.310	-0.3	41.9	57.7	40.2	288.3	1.151	10.08	1.597
9	15.471	16.180	0.3	44.1	55.9	36.3	288.2	1.144	10.07	1.565
10	14.079	15.049	0.7	44.4	54.1	32.2	288.3	1.133	10.07	1.510
11	13.360	14.483	1.2	48.6	53.3	19.6	288.8	1.153	10.02	1.602

RP	ABS VEL		REL VEL		MERID VEL		TANG VEL		WHEEL SPEED	
	IN	OUT	IN	OUT	IN	OUT	IN	OUT	IN	OUT
1	169.9	176.1	450.4	271.1	169.9	83.0	-1.4	155.3	415.7	413.4
2	179.1	191.4	444.5	282.9	179.1	119.9	0.9	149.3	407.6	405.5
3	184.8	201.0	421.2	279.4	184.8	143.2	3.8	141.0	382.3	381.0
4	185.3	204.8	408.6	274.9	185.3	151.8	2.7	137.5	366.8	366.7
5	186.0	211.9	394.2	256.1	185.9	153.4	2.6	146.2	350.2	351.2
6	185.3	207.8	379.8	246.0	185.2	151.4	2.3	142.4	333.8	336.3
7	184.7	209.1	372.2	243.7	184.7	155.0	2.0	140.3	325.1	328.4
8	179.2	224.5	335.5	218.6	179.2	167.0	-0.9	150.1	282.7	291.1
9	175.4	222.4	313.2	198.3	175.4	159.7	0.8	154.7	260.2	272.2
10	170.2	220.1	289.9	186.0	170.2	157.4	2.0	153.9	236.7	253.0
11	165.4	247.5	276.6	173.9	165.4	163.8	3.3	185.6	225.0	243.9

RP	ABS MACH NO		REL MACH NO		MERID MACH NO		MERID PEAK SS	
	IN	OUT	IN	OUT	IN	OUT	VEL R	MACH NO
1	0.511	0.478	1.354	0.735	0.511	0.225	0.489	1.576
2	0.540	0.525	1.340	0.776	0.540	0.329	0.669	1.547
3	0.558	0.559	1.273	0.777	0.558	0.398	0.775	1.482
4	0.561	0.574	1.236	0.770	0.561	0.425	0.819	1.495
5	0.563	0.594	1.193	0.718	0.563	0.430	0.825	1.482
6	0.561	0.585	1.149	0.693	0.561	0.426	0.817	1.477
7	0.559	0.591	1.126	0.688	0.559	0.438	0.839	1.474
8	0.542	0.640	1.014	0.623	0.542	0.476	0.932	1.496
9	0.530	0.635	0.946	0.566	0.530	0.456	0.911	1.438
10	0.513	0.632	0.874	0.534	0.513	0.452	0.925	1.354
11	0.497	0.710	0.832	0.499	0.497	0.470	0.991	1.305

RP	PERCENT		INCIDENCE		DEV	D-FACT	EFF	LOSS COEFF		LOSS PARAM	
	SPAN	MEAN	SS	TOT				PROF	TOT	PROF	
1	5.00	6.2	3.3	14.2	0.520	0.607	0.341	0.251	0.037	0.027	
2	10.00	5.6	2.4	7.9	0.478	0.685	0.266	0.185	0.039	0.027	
3	20.00	5.4	1.6	4.0	0.443	0.797	0.167	0.109	0.028	0.018	
4	30.00	6.4	2.1	3.5	0.430	0.857	0.117	0.062	0.020	0.011	
5	38.00	6.7	2.0	2.5	0.459	0.866	0.116	0.069	0.021	0.012	
6	46.00	7.2	2.1	4.0	0.457	0.864	0.117	0.076	0.020	0.013	
7	50.00	7.4	2.1	4.0	0.448	0.903	0.084	0.046	0.015	0.008	
8	70.00	8.7	2.7	4.6	0.458	0.945	0.053	0.025	0.010	0.005	
9	80.00	9.0	2.6	8.7	0.478	0.945	0.057	0.042	0.010	0.008	
10	90.00	9.3	2.7	14.7	0.467	0.943	0.062	0.058	0.011	0.010	
11	95.00	9.7	3.0	8.0	0.502	0.943	0.076	0.075	0.014	0.013	

TABLE VIII. - Continued.

(l) Reading 856

RP	RADII		ABS BETAM		REL BETAM		TOTAL TEMP		TOTAL PRESS	
	IN	OUT	IN	OUT	IN	OUT	IN	RATIO	IN	RATIO
1	24.795	24.656	-0.5	61.5	67.2	73.1	289.9	1.214	9.93	1.534
2	24.216	24.092	0.0	49.0	65.6	64.5	289.6	1.200	10.08	1.584
3	23.040	22.962	0.8	43.2	63.6	59.6	289.4	1.178	10.08	1.589
4	21.841	21.831	0.6	41.5	62.3	56.8	289.0	1.168	10.09	1.592
5	20.866	20.927	0.7	43.2	61.2	53.4	288.8	1.172	10.10	1.623
6	19.878	20.023	0.6	42.6	60.1	52.4	288.7	1.160	10.10	1.564
7	19.378	19.571	0.6	41.3	59.6	50.6	288.6	1.154	10.10	1.578
8	16.812	17.310	-0.5	39.7	57.0	39.1	288.3	1.149	10.08	1.588
9	15.471	16.180	-0.0	42.2	55.3	34.1	288.3	1.146	10.07	1.578
10	14.079	15.049	0.8	42.5	53.3	30.7	288.4	1.132	10.04	1.511
11	13.360	14.483	0.8	46.7	52.6	19.4	288.8	1.151	9.99	1.590

RP	ABS VEL		REL VEL		MERID VEL		TANG VEL		WHEEL SPEED	
	IN	OUT	IN	OUT	IN	OUT	IN	OUT	IN	OUT
1	176.2	169.4	454.5	278.2	176.2	80.8	-1.5	148.9	417.5	415.1
2	185.0	190.4	447.5	290.0	185.0	124.9	0.1	143.7	407.5	405.4
3	190.8	200.1	429.2	288.6	190.8	145.9	2.8	136.9	387.3	386.0
4	191.3	203.1	412.1	277.6	191.3	152.1	2.1	134.7	367.1	367.0
5	191.7	211.2	397.8	258.2	191.7	153.9	2.4	144.6	350.9	351.9
6	191.0	206.6	383.5	249.0	191.0	152.1	2.0	139.8	334.5	337.0
7	190.4	209.1	375.6	247.5	190.3	157.2	2.0	137.9	325.8	329.0
8	184.7	229.9	338.8	227.9	184.7	176.8	-1.6	147.0	282.5	290.8
9	180.6	232.0	317.0	207.7	180.6	171.9	-0.2	155.8	260.4	272.3
10	174.5	227.4	292.2	194.8	174.5	167.5	2.4	153.7	236.8	253.1
11	169.4	250.9	279.1	182.4	169.4	172.0	2.5	182.6	224.3	243.2

RP	ABS MACH NO		REL MACH NO		MERID MACH NO		MERID PEAK SS	
	IN	OUT	IN	OUT	IN	OUT	VEL R	MACH NO
1	0.531	0.460	1.368	0.755	0.531	0.219	0.458	1.568
2	0.559	0.523	1.352	0.797	0.559	0.343	0.675	1.536
3	0.578	0.557	1.300	0.804	0.578	0.406	0.765	1.495
4	0.580	0.569	1.249	0.778	0.580	0.426	0.795	1.483
5	0.581	0.592	1.206	0.724	0.581	0.432	0.803	1.470
6	0.579	0.582	1.163	0.702	0.579	0.428	0.796	1.464
7	0.577	0.591	1.139	0.700	0.577	0.444	0.826	1.460
8	0.559	0.657	1.026	0.651	0.559	0.505	0.957	1.474
9	0.546	0.664	0.959	0.595	0.546	0.492	0.951	1.436
10	0.527	0.654	0.882	0.560	0.527	0.482	0.960	1.345
11	0.510	0.721	0.840	0.524	0.510	0.495	1.016	1.300

RP	PERCENT		INCIDENCE		DEV	D-FACT	EFF	LOSS COEFF		LOSS PARAM	
	SPAN	MEAN	SS	TOT				PROF	TOT	PROF	
1	5.00	5.6	2.7	15.2	0.504	0.608	0.327	0.237	0.033	0.024	
2	10.00	5.0	1.8	7.4	0.462	0.702	0.244	0.164	0.036	0.024	
3	20.00	5.0	1.2	4.4	0.429	0.795	0.163	0.098	0.027	0.016	
4	30.00	5.7	1.4	3.8	0.426	0.847	0.122	0.067	0.021	0.011	
5	38.00	6.0	1.4	2.7	0.457	0.861	0.119	0.072	0.021	0.013	
6	46.00	6.5	1.4	4.3	0.453	0.852	0.124	0.083	0.021	0.014	
7	50.00	6.7	1.4	4.1	0.442	0.902	0.082	0.045	0.014	0.008	
8	70.00	8.0	1.9	3.6	0.434	0.947	0.051	0.024	0.009	0.004	
9	80.00	8.3	1.9	6.5	0.456	0.951	0.051	0.035	0.009	0.006	
10	90.00	8.6	2.0	13.1	0.441	0.946	0.058	0.054	0.010	0.009	
11	95.00	9.0	2.4	7.8	0.474	0.936	0.083	0.082	0.015	0.015	

TABLE VIII. - Continued.

(m) Reading 867

RP	RADII		ABS BETAM		REL BETAM		TOTAL TEMP		TOTAL PRESS	
	IN	OUT	IN	OUT	IN	OUT	IN	RATIO	IN	RATIO
1	24.795	24.656	-0.4	60.9	66.6	74.1	289.9	1.200	9.92	1.484
2	24.216	24.092	0.1	45.2	65.0	64.2	289.6	1.183	10.08	1.550
3	23.040	22.962	0.8	40.1	63.0	59.4	289.4	1.166	10.09	1.550
4	21.841	21.831	0.5	39.8	61.7	56.7	289.0	1.161	10.09	1.561
5	20.866	20.927	0.7	42.4	60.4	53.5	288.8	1.168	10.10	1.586
6	19.878	20.023	0.6	41.6	59.4	52.8	288.7	1.154	10.10	1.522
7	19.378	19.571	0.6	39.7	58.9	50.6	288.7	1.148	10.10	1.544
8	16.812	17.310	-0.4	37.8	56.4	38.6	288.4	1.145	10.07	1.568
9	15.471	16.180	-0.0	40.4	54.6	32.8	288.4	1.144	10.05	1.565
10	14.079	15.049	0.5	40.9	52.9	29.3	288.5	1.132	10.02	1.509
11	13.360	14.483	0.3	45.1	52.6	19.9	288.8	1.149	9.94	1.569

RP	ABS VEL		REL VEL		MERID VEL		TANG VEL		WHEEL SPEED	
	IN	OUT	IN	OUT	IN	OUT	IN	OUT	IN	OUT
1	180.7	160.0	454.8	284.9	180.7	77.9	-1.3	139.7	416.1	413.7
2	189.8	186.6	448.4	302.0	189.8	131.4	0.3	132.5	406.5	404.4
3	195.9	198.7	430.8	298.7	195.9	152.1	2.6	127.9	386.3	385.0
4	196.3	202.3	413.7	282.9	196.3	155.5	1.7	129.3	365.8	365.7
5	196.7	209.3	398.6	260.1	196.6	154.6	2.5	141.1	349.2	350.2
6	195.8	203.9	385.1	252.1	195.8	152.4	2.2	135.4	333.8	336.2
7	195.0	208.0	377.0	252.2	195.0	160.1	1.9	132.9	324.5	327.7
8	188.5	233.9	340.6	236.3	188.5	184.7	-1.4	143.4	282.3	290.7
9	184.1	237.5	317.5	215.3	184.1	181.0	-0.1	153.8	258.6	270.5
10	177.1	233.8	293.9	202.6	177.1	176.6	1.7	153.2	236.2	252.4
11	170.3	251.9	280.7	188.9	170.3	177.7	0.8	178.5	223.9	242.8

RP	ABS MACH NO		REL MACH NO		MERID MACH NO		MERID PEAK SS	
	IN	OUT	IN	OUT	IN	OUT	VEL R	MACH NO
1	0.545	0.436	1.371	0.776	0.545	0.212	0.431	1.551
2	0.575	0.516	1.357	0.835	0.575	0.364	0.692	1.519
3	0.594	0.556	1.307	0.836	0.594	0.426	0.776	1.479
4	0.596	0.568	1.256	0.795	0.596	0.437	0.792	1.466
5	0.597	0.588	1.211	0.731	0.597	0.434	0.786	1.449
6	0.595	0.575	1.170	0.712	0.595	0.430	0.779	1.446
7	0.592	0.590	1.145	0.715	0.592	0.454	0.821	1.440
8	0.572	0.670	1.033	0.677	0.572	0.530	0.980	1.457
9	0.557	0.682	0.961	0.618	0.557	0.520	0.983	1.417
10	0.535	0.674	0.887	0.584	0.535	0.509	0.997	1.342
11	0.513	0.725	0.845	0.544	0.513	0.512	1.043	1.308

RP	PERCENT		INCIDENCE		DEV	D-FACT	EFF	LOSS COEFF		LOSS PARAM	
	SPAN	MEAN	SS	TOT				PROF	TOT	PROF	
1	5.00	5.0	2.1	16.2	0.482	0.597	0.318	0.231	0.031	0.022	
2	10.00	4.3	1.1	7.2	0.427	0.727	0.209	0.131	0.031	0.020	
3	20.00	4.3	0.6	4.2	0.401	0.805	0.145	0.083	0.024	0.014	
4	30.00	5.0	0.7	3.7	0.412	0.844	0.119	0.066	0.020	0.011	
5	38.00	5.3	0.6	2.8	0.451	0.840	0.132	0.088	0.023	0.015	
6	46.00	5.8	0.7	4.7	0.444	0.827	0.139	0.100	0.024	0.017	
7	50.00	6.0	0.7	4.1	0.428	0.892	0.087	0.052	0.015	0.009	
8	70.00	7.4	1.3	3.0	0.410	0.947	0.049	0.024	0.009	0.004	
9	80.00	7.6	1.2	5.2	0.431	0.948	0.052	0.038	0.010	0.007	
10	90.00	8.2	1.6	11.8	0.418	0.945	0.058	0.054	0.010	0.009	
11	95.00	9.0	2.4	8.2	0.452	0.924	0.096	0.095	0.017	0.017	

TABLE VIII. - Continued.

(n) Reading 884

RP	RADII		ABS BETAM		REL BETAM		TOTAL TEMP		TOTAL PRESS	
	IN	OUT	IN	OUT	IN	OUT	IN	RATIO	IN	RATIO
1	24.795	24.656	-0.5	59.6	65.9	75.4	289.9	1.184	9.92	1.415
2	24.216	24.092	-0.0	41.1	64.4	63.5	289.7	1.172	10.07	1.516
3	23.040	22.962	0.6	35.5	62.4	58.9	289.4	1.152	10.10	1.510
4	21.841	21.831	0.4	36.6	61.1	56.2	289.0	1.153	10.10	1.528
5	20.866	20.927	0.6	40.4	59.9	53.6	288.9	1.162	10.10	1.547
6	19.878	20.023	0.7	40.2	58.8	53.7	288.8	1.147	10.10	1.457
7	19.378	19.571	0.7	38.4	58.2	51.1	288.7	1.144	10.09	1.491
8	16.812	17.310	-0.1	35.5	55.6	38.9	288.4	1.138	10.06	1.536
9	15.471	16.180	0.1	37.2	54.0	33.8	288.3	1.136	10.04	1.531
10	14.079	15.049	0.3	39.3	52.3	27.6	288.4	1.134	9.99	1.532
11	13.360	14.483	0.6	43.9	51.6	20.2	288.7	1.147	9.95	1.552

RP	ABS VEL		REL VEL		MERID VEL		TANG VEL		WHEEL SPEED	
	IN	OUT	IN	OUT	IN	OUT	IN	OUT	IN	OUT
1	186.8	148.1	458.3	296.3	186.8	74.8	-1.7	127.8	416.8	414.5
2	195.9	187.2	452.8	316.1	195.9	141.0	-0.1	123.1	408.2	406.1
3	202.3	200.6	436.0	315.9	202.3	163.3	2.0	116.5	388.2	386.9
4	202.7	204.9	419.3	296.2	202.7	164.6	1.5	122.1	368.5	368.4
5	202.7	209.8	403.9	269.4	202.7	159.8	2.3	135.9	351.7	352.7
6	201.7	200.2	388.9	258.4	201.7	152.9	2.6	129.2	335.0	337.5
7	200.9	207.1	381.5	258.5	200.9	162.2	2.4	128.7	326.7	330.0
8	194.1	235.7	343.8	246.6	194.1	191.9	-0.3	136.8	283.4	291.8
9	189.1	239.8	322.0	229.9	189.1	191.0	0.3	144.9	261.0	272.9
10	182.1	244.1	298.1	213.3	182.1	188.9	1.0	154.5	237.1	253.4
11	177.2	254.9	285.2	195.8	177.2	183.8	1.8	176.6	225.3	244.2

RP	ABS MACH NO		REL MACH NO		MERID MACH NO		MERID PEAK SS	
	IN	OUT	IN	OUT	IN	OUT	VEL R	MACH NO
1	0.564	0.405	1.385	0.811	0.564	0.205	0.401	1.542
2	0.594	0.520	1.373	0.879	0.594	0.392	0.720	1.515
3	0.615	0.565	1.326	0.890	0.615	0.460	0.807	1.477
4	0.617	0.579	1.276	0.837	0.617	0.465	0.812	1.465
5	0.617	0.591	1.230	0.759	0.617	0.450	0.789	1.446
6	0.614	0.566	1.184	0.731	0.614	0.432	0.758	1.434
7	0.611	0.588	1.161	0.734	0.611	0.461	0.808	1.432
8	0.590	0.678	1.044	0.710	0.590	0.552	0.988	1.435
9	0.574	0.692	0.977	0.663	0.574	0.551	1.010	1.422
10	0.551	0.706	0.902	0.617	0.551	0.547	1.037	1.345
11	0.535	0.736	0.861	0.565	0.535	0.530	1.037	1.301

RP	PERCENT		INCIDENCE		DEV	D-FACT	EFF	LOSS COEFF		LOSS PARAM	
	SPAN	MEAN	SS	SS				TOT	PROF	TOT	PROF
1	5.00	4.3	1.4	17.4	0.452	0.565	0.318	0.231	0.028	0.020	
2	10.00	3.8	0.6	6.5	0.395	0.734	0.192	0.112	0.029	0.017	
3	20.00	3.7	-0.0	3.7	0.361	0.820	0.124	0.059	0.021	0.010	
4	30.00	4.4	0.2	3.3	0.383	0.843	0.113	0.058	0.020	0.010	
5	38.00	4.7	0.1	2.9	0.431	0.818	0.143	0.097	0.025	0.017	
6	46.00	5.1	0.1	5.7	0.428	0.770	0.173	0.135	0.029	0.023	
7	50.00	5.4	0.1	4.7	0.414	0.841	0.122	0.087	0.021	0.015	
8	70.00	6.7	0.6	3.4	0.380	0.945	0.048	0.024	0.009	0.005	
9	80.00	7.1	0.7	6.2	0.388	0.951	0.047	0.031	0.009	0.006	
10	90.00	7.6	1.0	10.1	0.391	0.965	0.037	0.033	0.007	0.006	
11	95.00	8.0	1.3	8.6	0.435	0.909	0.111	0.109	0.020	0.019	

TABLE VIII. - Continued.

(o) Reading 895

RP	RADII		ABS BETAM		REL BETAM		TOTAL TEMP		TOTAL PRESS	
	IN	OUT	IN	OUT	IN	OUT	IN	RATIO	IN	RATIO
1	24.795	24.656	-0.5	44.4	65.5	69.2	289.9	1.163	9.92	1.364
2	24.216	24.092	-0.2	35.6	63.9	63.7	289.7	1.142	10.08	1.414
3	23.040	22.962	0.3	30.7	61.9	59.9	289.3	1.131	10.09	1.433
4	21.841	21.831	0.3	31.7	60.5	57.1	289.0	1.132	10.10	1.438
5	20.866	20.927	0.5	36.0	59.3	55.5	288.9	1.141	10.10	1.458
6	19.878	20.023	0.6	36.8	58.2	57.0	288.8	1.126	10.09	1.334
7	19.378	19.571	0.7	35.8	57.6	54.0	288.8	1.126	10.09	1.376
8	16.812	17.310	-0.3	33.7	55.1	38.7	288.5	1.135	10.06	1.488
9	15.471	16.180	0.5	34.4	53.3	33.4	288.4	1.130	10.03	1.503
10	14.079	15.049	0.6	37.3	51.9	25.9	288.5	1.134	9.97	1.535
11	13.360	14.483	0.5	40.7	51.3	20.6	288.8	1.142	9.91	1.532

RP	ABS VEL		REL VEL		MERID VEL		TANG VEL		WHEEL SPEED	
	IN	OUT	IN	OUT	IN	OUT	IN	OUT	IN	OUT
1	191.6	161.2	461.8	324.7	191.6	115.2	-1.6	112.7	418.6	416.2
2	200.6	181.7	456.2	341.5	200.6	151.3	-0.8	100.7	408.9	406.8
3	206.9	194.4	439.5	333.0	206.9	167.1	1.0	99.3	388.7	387.4
4	207.5	199.9	421.7	313.1	207.5	170.0	1.2	105.1	368.3	368.1
5	207.4	200.0	406.8	285.5	207.4	161.7	1.9	117.7	351.9	352.9
6	206.2	184.2	391.9	271.1	206.2	147.5	2.2	110.3	335.4	337.8
7	205.5	194.2	383.8	267.7	205.5	157.4	2.6	113.6	326.8	330.1
8	198.6	239.3	347.3	255.2	198.6	199.1	-1.0	132.8	284.0	292.4
9	193.2	246.2	323.5	243.4	193.2	203.2	1.5	139.0	261.0	272.9
10	185.2	256.1	299.8	226.4	185.1	203.6	2.0	155.3	237.8	254.2
11	179.3	261.0	286.9	211.4	179.3	198.0	1.5	170.1	225.4	244.4

RP	ABS MACH NO		REL MACH NO		MERID MACH NO		MERID PEAK SS	
	IN	OUT	IN	OUT	IN	OUT	VEL R	MACH NO
1	0.580	0.447	1.398	0.900	0.580	0.319	0.601	1.539
2	0.609	0.511	1.386	0.961	0.609	0.426	0.754	1.512
3	0.630	0.552	1.339	0.946	0.630	0.475	0.807	1.475
4	0.633	0.569	1.286	0.891	0.633	0.384	0.819	1.454
5	0.633	0.567	1.241	0.809	0.633	0.459	0.780	1.437
6	0.629	0.523	1.195	0.770	0.629	0.419	0.715	1.426
7	0.626	0.553	1.170	0.763	0.626	0.449	0.766	1.418
8	0.634	0.690	1.056	0.736	0.604	0.574	1.003	1.424
9	0.587	0.714	0.982	0.706	0.587	0.590	1.052	1.406
10	0.561	0.744	0.908	0.658	0.561	0.592	1.100	1.339
11	0.542	0.757	0.866	0.613	0.542	0.574	1.104	1.302

RP	PERCENT		INCIDENCE		DEV	D-FACT	EFF	LOSS COEFF		LOSS PARAM	
	SPAN	MEAN	SS	TOT				PROF	TOT	PROF	
1	5.00	3.9	1.0	11.3	0.384	0.569	0.284	0.196	0.035	0.024	
2	10.00	3.3	0.1	6.7	0.328	0.734	0.162	0.081	0.025	0.012	
3	20.00	3.3	-0.4	4.7	0.315	0.826	0.104	0.038	0.017	0.006	
4	30.00	3.8	-0.4	4.1	0.334	0.829	0.108	0.053	0.018	0.009	
5	38.00	4.2	-0.5	4.7	0.383	0.808	0.133	0.087	0.022	0.015	
6	46.00	4.6	-0.5	9.0	0.387	0.682	0.206	0.167	0.032	0.026	
7	50.00	4.8	-0.5	7.5	0.383	0.755	0.165	0.130	0.027	0.021	
8	70.00	6.2	0.1	3.1	0.359	0.893	0.089	0.066	0.017	0.012	
9	80.00	6.4	0.0	5.8	0.344	0.953	0.042	0.028	0.008	0.005	
10	90.00	7.1	0.5	8.4	0.351	0.969	0.033	0.028	0.006	0.005	
11	95.00	7.7	1.0	8.9	0.379	0.912	0.103	0.101	0.018	0.018	

TABLE VIII. - Continued.

(p) Reading 916

RP	RADII		ABS BETAM		REL BETAM		TOTAL TEMP		TOTAL PRESS	
	IN	OUT	IN	OUT	IN	OUT	IN	RATIO	IN	RATIO
1	24.795	24.656	-0.6	58.2	69.1	61.7	289.6	1.278	9.96	1.828
2	24.216	24.092	0.8	50.4	67.6	59.9	289.5	1.231	10.08	1.781
3	23.040	22.962	1.5	45.9	65.8	57.1	289.4	1.202	10.07	1.766
4	21.841	21.831	0.7	46.1	64.7	55.3	288.8	1.194	10.11	1.740
5	20.866	20.927	0.7	49.9	63.6	54.5	288.7	1.196	10.11	1.711
6	19.878	20.023	0.4	53.3	62.6	54.5	288.6	1.192	10.11	1.650
7	19.378	19.571	0.2	53.3	61.9	52.8	288.6	1.188	10.10	1.640
8	16.812	17.310	-1.1	49.8	59.4	46.5	288.0	1.158	10.09	1.578
9	15.471	16.180	-0.5	51.0	57.6	40.9	288.1	1.152	10.09	1.566
10	14.079	15.049	-0.3	50.9	56.2	32.1	288.1	1.148	10.07	1.574
11	13.360	14.483	-0.2	53.0	55.5	19.2	288.3	1.164	10.03	1.660

RP	ABS VEL		REL VEL		MERID VEL		TANG VEL		WHEEL SPEED	
	IN	OUT	IN	OUT	IN	OUT	IN	OUT	IN	OUT
1	160.2	227.1	448.6	252.1	160.2	119.6	-1.7	193.0	417.3	414.9
2	168.1	217.7	440.2	276.6	168.1	138.7	2.3	167.8	409.2	407.1
3	173.2	216.8	422.7	277.5	173.1	150.8	4.4	155.8	390.0	388.7
4	174.2	214.8	407.1	261.6	174.1	148.8	2.1	154.8	370.1	369.9
5	174.7	213.1	393.0	236.2	174.6	137.2	2.2	163.1	354.3	355.3
6	173.9	207.3	378.4	213.2	173.9	123.8	1.3	166.2	337.4	339.9
7	173.3	206.4	367.8	204.3	173.3	123.4	0.6	165.4	324.9	328.2
8	168.5	200.7	330.8	188.3	168.5	129.6	-3.3	153.2	281.4	289.7
9	165.4	205.0	308.4	170.5	165.4	129.0	-1.4	159.3	259.0	270.9
10	159.8	217.0	287.1	161.7	159.8	137.0	-0.7	168.3	237.8	254.2
11	155.4	243.0	274.6	154.9	155.4	146.3	-0.4	194.0	226.0	245.0

RP	ABS MACH NO		REL MACH NO		MERID MACH NO		MERID PEAK SS	
	IN	OUT	IN	OUT	IN	OUT	VEL R	MACH NO
1	0.480	0.610	1.345	0.678	0.480	0.322	0.747	1.609
2	0.505	0.595	1.323	0.757	0.505	0.379	0.825	1.575
3	0.521	0.601	1.273	0.769	0.521	0.418	0.871	1.545
4	0.525	0.597	1.228	0.728	0.525	0.414	0.855	1.543
5	0.527	0.592	1.185	0.656	0.527	0.381	0.786	1.535
6	0.524	0.576	1.141	0.592	0.524	0.344	0.712	1.533
7	0.523	0.574	1.109	0.568	0.523	0.343	0.712	1.518
8	0.508	0.566	0.997	0.531	0.508	0.365	0.769	1.544
9	0.498	0.580	0.929	0.483	0.498	0.365	0.780	1.464
10	0.480	0.617	0.863	0.460	0.480	0.390	0.857	1.399
11	0.466	0.693	0.824	0.442	0.466	0.417	0.942	1.356

RP	PERCENT		INCIDENCE		DEV	D-FACT	EFF	LOSS COEFF		LOSS PARAM	
	SPAN	MEAN	SS	SS				TOT	PROF	TOT	PROF
1	5.00	7.5	4.5	3.7	0.590	0.676	0.338	0.243	0.056	0.040	
2	10.00	6.9	3.7	2.9	0.500	0.776	0.213	0.129	0.037	0.022	
3	20.00	7.2	3.5	1.9	0.460	0.875	0.114	0.044	0.020	0.008	
4	30.00	8.0	3.7	2.3	0.474	0.884	0.107	0.044	0.019	0.008	
5	38.00	8.5	3.8	3.7	0.521	0.846	0.148	0.092	0.025	0.016	
6	46.00	9.0	3.9	6.5	0.560	0.800	0.197	0.147	0.032	0.024	
7	50.00	9.0	3.8	6.4	0.569	0.809	0.191	0.149	0.032	0.025	
8	70.00	10.4	4.3	10.9	0.546	0.882	0.121	0.087	0.020	0.014	
9	80.00	10.6	4.3	13.2	0.565	0.902	0.108	0.092	0.018	0.015	
10	90.00	11.4	4.8	14.6	0.559	0.934	0.080	0.074	0.014	0.013	
11	95.00	11.9	5.3	7.6	0.576	0.949	0.072	0.070	0.013	0.013	

TABLE VIII. - Continued.

(q) Reading 927

RP	RADII		ABS BETAM		REL BETAM		TOTAL TEMP		TOTAL PRESS	
	IN	OUT	IN	OUT	IN	OUT	IN	RATIO	IN	RATIO
1	24.795	24.656	-0.8	53.9	68.1	60.4	290.0	1.260	9.92	1.783
2	24.216	24.092	0.4	47.9	66.5	59.9	289.5	1.219	10.08	1.729
3	23.040	22.962	1.3	44.2	64.4	57.7	289.3	1.189	10.07	1.697
4	21.841	21.831	0.7	43.9	63.2	55.7	288.7	1.181	10.10	1.687
5	20.866	20.927	0.7	45.6	62.1	53.6	288.8	1.180	10.10	1.673
6	19.878	20.023	0.5	46.6	61.1	52.5	288.7	1.173	10.11	1.642
7	19.378	19.571	0.2	46.8	60.6	51.5	288.7	1.170	10.11	1.630
8	16.812	17.310	-1.2	47.8	58.0	46.5	288.4	1.152	10.08	1.594
9	15.471	16.180	-0.6	49.8	56.2	44.0	288.4	1.142	10.08	1.548
10	14.079	15.049	-0.3	50.7	54.5	36.5	288.7	1.138	10.07	1.540
11	13.360	14.483	-0.4	52.8	54.0	22.9	288.7	1.155	10.01	1.629

RP	ABS VEL		REL VEL		MERID VEL		TANG VEL		WHEEL SPEED	
	IN	OUT	IN	OUT	IN	OUT	IN	OUT	IN	OUT
1	167.6	223.7	449.4	266.5	167.6	131.8	-2.2	180.8	414.8	412.4
2	177.3	214.5	445.1	287.1	177.3	143.9	1.3	159.1	409.6	407.5
3	183.2	210.4	423.8	282.0	183.2	150.8	4.0	146.7	386.3	384.9
4	184.0	209.5	408.3	268.0	183.9	151.1	2.1	145.2	366.7	366.5
5	184.3	211.2	394.1	249.0	184.2	147.7	2.2	151.0	350.5	351.5
6	183.6	207.3	380.0	234.4	183.6	142.6	1.4	150.5	334.1	336.5
7	183.1	206.4	372.6	226.9	183.1	141.2	0.5	150.6	325.0	328.2
8	178.0	200.1	336.3	195.3	178.0	134.4	-3.6	148.3	281.7	290.1
9	174.8	195.6	314.2	175.3	174.8	126.2	-1.7	149.5	259.4	271.2
10	169.1	203.4	291.4	160.4	169.1	129.0	-0.9	157.3	236.4	252.7
11	163.6	230.8	278.3	151.4	163.6	139.4	-1.1	183.9	224.0	242.8

RP	ABS MACH NO		REL MACH NO		MERID MACH NO		MERID PEAK SS	
	IN	OUT	IN	OUT	IN	OUT	VEL R	MACH NO
1	0.503	0.605	1.349	0.721	0.503	0.356	0.787	1.581
2	0.534	0.589	1.341	0.788	0.534	0.395	0.812	1.558
3	0.553	0.585	1.280	0.784	0.553	0.419	0.824	1.504
4	0.556	0.585	1.235	0.749	0.556	0.422	0.821	1.501
5	0.557	0.590	1.192	0.696	0.557	0.413	0.801	1.499
6	0.555	0.581	1.149	0.657	0.555	0.399	0.776	1.487
7	0.554	0.579	1.127	0.636	0.554	0.396	0.771	1.485
8	0.538	0.565	1.016	0.551	0.538	0.379	0.755	1.507
9	0.528	0.554	0.948	0.497	0.528	0.357	0.722	1.450
10	0.509	0.578	0.877	0.456	0.509	0.367	0.763	1.374
11	0.492	0.657	0.836	0.431	0.492	0.397	0.852	1.332

RP	PERCENT		INCIDENCE		DEV	D-FACT	EFF	LOSS COEFF		LOSS PARAM	
	SPAN	MEAN	SS	SS				TOT	PROF	TOT	PROF
1	5.00	6.5	3.6	2.4	0.549	0.692	0.307	0.217	0.053	0.038	
2	10.00	5.9	2.7	2.9	0.476	0.772	0.205	0.121	0.035	0.021	
3	20.00	5.8	2.0	2.5	0.444	0.862	0.118	0.055	0.021	0.010	
4	30.00	6.6	2.3	2.7	0.452	0.892	0.094	0.037	0.016	0.007	
5	38.00	7.0	2.3	2.9	0.480	0.878	0.109	0.061	0.019	0.011	
6	46.00	7.5	2.4	4.5	0.495	0.881	0.108	0.065	0.019	0.011	
7	50.00	7.7	2.4	5.1	0.503	0.882	0.109	0.069	0.019	0.012	
8	70.00	9.1	3.0	11.0	0.529	0.936	0.062	0.032	0.010	0.005	
9	80.00	9.3	2.9	16.3	0.551	0.939	0.062	0.046	0.010	0.007	
10	90.00	9.8	3.2	19.0	0.562	0.953	0.053	0.048	0.008	0.008	
11	95.00	10.4	3.7	11.3	0.587	0.965	0.046	0.044	0.008	0.008	

TABLE VIII. - Continued.

(r) Reading 938

RP	RADII		ABS BETAM		REL BETAM		TOTAL TEMP		TOTAL PRESS	
	IN	OUT	IN	OUT	IN	OUT	IN	RATIO	IN	RATIO
1	24.795	24.656	-0.9	52.6	67.1	63.7	290.0	1.235	9.92	1.682
2	24.216	24.092	0.2	46.2	65.3	61.9	289.7	1.200	10.08	1.651
3	23.040	22.962	1.0	43.0	63.4	59.4	289.4	1.178	10.08	1.638
4	21.841	21.831	0.5	43.1	62.2	57.1	289.0	1.173	10.10	1.634
5	20.866	20.927	0.7	44.7	61.0	55.1	289.0	1.171	10.10	1.629
6	19.878	20.023	0.5	43.9	59.9	53.9	288.8	1.159	10.11	1.586
7	19.378	19.571	0.4	43.0	59.4	51.9	288.6	1.156	10.10	1.599
8	16.812	17.310	-1.0	42.2	57.0	42.6	288.5	1.148	10.07	1.595
9	15.471	16.180	-0.5	44.6	55.2	39.2	288.5	1.141	10.06	1.558
10	14.079	15.049	-0.6	45.2	53.7	33.7	288.5	1.134	10.03	1.531
11	13.360	14.483	-0.7	47.9	53.2	22.4	288.9	1.150	9.97	1.614

RP	ABS VEL		REL VEL		MERID VEL		TANG VEL		WHEEL SPEED	
	IN	OUT	IN	OUT	IN	OUT	IN	OUT	IN	OUT
1	176.9	204.6	454.9	280.4	176.8	124.2	-2.8	162.5	416.3	414.0
2	186.4	200.5	446.7	294.3	186.4	138.7	0.6	144.8	406.5	404.4
3	192.2	200.8	429.0	288.5	192.2	146.8	3.2	137.1	386.7	385.4
4	192.6	202.6	412.8	271.9	192.6	147.9	1.8	138.4	366.9	366.7
5	193.0	204.0	397.5	253.1	193.0	145.0	2.5	143.6	350.0	351.1
6	192.4	199.8	383.5	244.0	192.4	143.8	1.6	138.6	333.3	335.8
7	191.7	203.3	376.2	241.0	191.7	148.7	1.4	138.6	325.1	328.3
8	185.5	214.8	340.5	216.3	185.5	159.2	-3.2	144.2	282.3	290.7
9	181.7	211.6	318.2	194.6	181.7	150.8	-1.6	148.5	259.6	271.4
10	174.8	214.1	295.5	181.5	174.8	150.9	-1.8	151.9	236.5	252.8
11	169.1	238.4	282.4	172.7	169.1	159.7	-2.2	177.0	224.0	242.8

RP	ABS MACH NO		REL MACH NO		MERID MACH NO		MERID PEAK SS	
	IN	OUT	IN	OUT	IN	OUT	VEL R	MACH NO
1	0.532	0.556	1.370	0.762	0.532	0.337	0.702	1.567
2	0.563	0.553	1.350	0.811	0.563	0.382	0.744	1.526
3	0.582	0.560	1.300	0.804	0.582	0.409	0.764	1.488
4	0.584	0.566	1.252	0.760	0.584	0.413	0.768	1.480
5	0.585	0.571	1.206	0.709	0.585	0.406	0.751	1.462
6	0.584	0.562	1.163	0.686	0.584	0.404	0.748	1.456
7	0.581	0.573	1.141	0.680	0.581	0.419	0.776	1.455
8	0.562	0.610	1.031	0.615	0.562	0.452	0.858	1.476
9	0.549	0.603	0.962	0.554	0.549	0.430	0.830	1.438
10	0.527	0.612	0.892	0.519	0.527	0.432	0.863	1.372
11	0.509	0.682	0.850	0.494	0.509	0.457	0.945	1.332

RP	PERCENT		INCIDENCE		DEV	D-FACT	EFF	LOSS COEFF		LOSS PARAM	
	SPAN	MEAN	MEAN	SS				TOT	PROF	TOT	PROF
1	5.00	5.5	2.6	5.8	0.511	0.683	0.288	0.198	0.045	0.031	
2	10.00	4.7	1.5	4.8	0.452	0.769	0.193	0.115	0.031	0.019	
3	20.00	4.8	1.0	4.2	0.429	0.853	0.117	0.054	0.019	0.009	
4	30.00	5.5	1.2	4.1	0.444	0.873	0.104	0.049	0.018	0.008	
5	38.00	5.8	1.1	4.3	0.469	0.876	0.105	0.059	0.018	0.010	
6	46.00	6.3	1.2	5.8	0.465	0.888	0.093	0.054	0.016	0.009	
7	50.00	6.5	1.2	5.5	0.461	0.924	0.064	0.028	0.011	0.005	
8	70.00	8.0	1.9	7.0	0.470	0.967	0.031	0.004	0.006	0.001	
9	80.00	8.2	1.9	11.6	0.495	0.960	0.039	0.023	0.007	0.004	
10	90.00	9.0	2.4	16.2	0.494	0.967	0.035	0.030	0.006	0.005	
11	95.00	9.6	2.9	10.7	0.514	0.977	0.029	0.026	0.005	0.005	

TABLE VIII. - Continued.

(s) Reading 950

RP	RAD II		ABS BETAM		REL BETAM		TOTAL TEMP		TOTAL PRESS	
	IN	OUT	IN	OUT	IN	OUT	IN	RATIO	IN	RATIO
1	24.795	24.656	-1.0	47.9	66.3	64.3	290.1	1.209	9.91	1.598
2	24.216	24.092	-0.0	42.0	64.5	63.0	289.6	1.177	10.07	1.567
3	23.040	22.962	0.6	39.6	62.5	60.3	289.3	1.161	10.08	1.572
4	21.841	21.831	0.4	40.5	61.2	57.4	289.0	1.161	10.10	1.574
5	20.866	20.927	0.5	43.3	60.0	55.8	288.9	1.163	10.10	1.575
6	19.878	20.023	0.5	42.8	59.0	55.3	288.8	1.150	10.10	1.512
7	19.378	19.571	0.4	41.0	58.5	53.0	288.8	1.146	10.10	1.537
8	16.812	17.310	-1.0	38.2	56.0	40.9	288.5	1.142	10.06	1.569
9	15.471	16.180	-0.5	40.6	54.3	35.7	288.5	1.140	10.04	1.562
10	14.079	15.049	-0.7	41.4	52.9	30.6	288.5	1.134	10.00	1.536
11	13.360	14.483	-1.1	44.4	52.5	22.2	288.7	1.146	9.94	1.592

RP	ABS VEL		REL VEL		MERID VEL		TANG VEL		WHEEL SPEED	
	IN	OUT	IN	OUT	IN	OUT	IN	OUT	IN	OUT
1	184.1	194.1	458.0	299.6	184.0	130.1	-3.1	144.0	416.3	414.0
2	193.3	190.1	449.7	310.6	193.3	141.2	-0.2	127.2	405.9	403.8
3	199.6	193.4	432.8	300.8	199.6	148.9	1.9	123.4	386.0	384.7
4	200.3	198.6	415.8	280.7	200.3	151.1	1.3	128.8	365.6	365.5
5	200.7	199.5	401.3	258.2	200.7	145.2	1.8	136.8	349.3	350.3
6	199.5	193.0	386.9	248.9	199.5	141.7	1.8	131.1	333.2	335.7
7	198.7	198.5	380.3	248.8	198.7	149.8	1.4	130.2	325.6	328.9
8	192.3	223.3	343.8	231.9	192.3	175.4	-3.3	138.2	281.6	290.0
9	188.0	226.8	321.9	212.2	188.0	172.3	-1.8	147.5	259.5	271.4
10	180.7	228.8	299.5	199.6	180.6	171.7	-2.3	151.2	236.6	252.9
11	174.5	245.5	286.7	189.5	174.4	175.5	-3.2	171.6	224.3	243.1

RP	ABS MACH NO		REL MACH NO		MERID MACH NO		MERID PEAK SS	
	IN	OUT	IN	OUT	IN	OUT	VEL R	MACH NO
1	0.555	0.532	1.382	0.821	0.555	0.356	0.707	1.552
2	0.586	0.528	1.362	0.862	0.586	0.392	0.730	1.511
3	0.606	0.542	1.315	0.842	0.606	0.417	0.746	1.473
4	0.609	0.557	1.264	0.788	0.609	0.424	0.754	1.457
5	0.610	0.560	1.221	0.724	0.610	0.407	0.724	1.442
6	0.607	0.544	1.176	0.701	0.607	0.399	0.710	1.435
7	0.604	0.561	1.156	0.704	0.604	0.424	0.754	1.437
8	0.584	0.638	1.043	0.663	0.584	0.501	0.912	1.447
9	0.570	0.650	0.975	0.608	0.570	0.494	0.917	1.428
10	0.546	0.658	0.905	0.574	0.546	0.494	0.951	1.368
11	0.526	0.706	0.865	0.545	0.526	0.505	1.006	1.334

RP	PERCENT	INCIDENCE		DEV	D-FACT	EFF	LOSS COEFF		LOSS PARAM	
	SPAN	MEAN	SS				TOT	PROF	TOT	PROF
1	5.00	4.7	1.8	6.3	0.458	0.687	0.259	0.170	0.039	0.026
2	10.00	3.9	0.7	5.9	0.406	0.774	0.169	0.092	0.026	0.014
3	20.00	3.9	0.2	5.1	0.397	0.857	0.104	0.041	0.017	0.007
4	30.00	4.5	0.3	4.5	0.420	0.861	0.106	0.054	0.018	0.009
5	38.00	4.9	0.2	5.0	0.457	0.848	0.122	0.077	0.020	0.013
6	46.00	5.3	0.3	7.2	0.452	0.838	0.126	0.088	0.020	0.014
7	50.00	5.6	0.4	6.5	0.440	0.896	0.082	0.046	0.014	0.008
8	70.00	7.0	0.9	5.3	0.426	0.969	0.027	0.003	0.005	0.001
9	80.00	7.3	0.9	8.1	0.445	0.973	0.026	0.010	0.005	0.002
10	90.00	8.1	1.5	13.1	0.440	0.977	0.024	0.017	0.004	0.003
11	95.00	8.9	2.2	10.5	0.459	0.971	0.035	0.032	0.006	0.006

TABLE VIII. - Concluded.

(t) Reading 963

RP	RADII		ABS BETAM		REL BETAM		TOTAL TEMP		TOTAL PRESS	
	IN	OUT	IN	OUT	IN	OUT	IN	RATIO	IN	RATIO
1	24.795	24.656	-1.1	38.8	65.7	64.4	290.1	1.168	9.88	1.481
2	24.216	24.092	-0.4	34.3	63.9	63.5	289.7	1.145	10.08	1.455
3	23.040	22.962	0.2	33.7	61.8	60.8	289.4	1.138	10.09	1.479
4	21.841	21.831	0.2	34.7	60.4	57.8	289.0	1.140	10.10	1.482
5	20.866	20.927	0.3	38.6	59.3	56.7	288.9	1.145	10.10	1.486
6	19.878	20.023	0.2	39.1	58.2	57.6	288.8	1.131	10.09	1.390
7	19.378	19.571	0.3	37.8	57.7	54.8	288.8	1.130	10.09	1.425
8	16.812	17.310	-1.0	34.7	55.4	40.8	288.4	1.133	10.05	1.498
9	15.471	16.180	-0.4	35.8	53.6	35.3	288.4	1.130	10.02	1.518
10	14.079	15.049	-0.5	37.8	52.1	27.9	288.4	1.133	9.99	1.532
11	13.360	14.483	-1.2	40.5	52.0	21.3	288.6	1.143	9.92	1.571

RP	ABS VEL		REL VEL		MERID VEL		TANG VEL		WHEEL SPEED	
	IN	OUT	IN	OUT	IN	OUT	IN	OUT	IN	OUT
1	189.4	183.6	460.5	331.3	189.4	143.0	-3.5	115.1	416.3	413.9
2	200.1	182.1	454.4	337.0	200.1	150.4	-1.5	102.7	406.4	404.3
3	207.0	188.9	438.2	322.0	207.0	157.2	0.8	104.7	387.1	385.8
4	207.2	195.2	419.8	300.8	207.2	160.4	0.7	111.2	365.8	365.6
5	207.1	193.3	405.4	275.3	207.1	151.1	1.1	120.5	349.6	350.6
6	206.0	181.0	390.9	262.3	206.0	140.5	0.9	114.1	333.1	335.5
7	205.2	189.5	383.7	259.8	205.2	149.7	1.1	116.2	325.3	328.6
8	197.5	227.5	347.5	247.1	197.5	187.1	-3.4	129.4	282.5	290.9
9	192.8	234.6	324.7	233.1	192.8	190.3	-1.4	137.2	259.9	271.8
10	185.6	245.2	301.9	219.1	185.6	193.6	-1.7	150.4	236.5	252.8
11	178.6	257.3	289.7	210.1	178.6	195.7	-3.6	167.1	224.6	243.4

RP	ABS MACH NO		REL MACH NO		MERID MACH NO		MERID PEAK SS	
	IN	OUT	IN	OUT	IN	OUT	VEL R	MACH NO
1	0.572	0.510	1.392	0.921	0.572	0.398	0.755	1.542
2	0.608	0.512	1.380	0.947	0.608	0.423	0.752	1.505
3	0.631	0.534	1.335	0.910	0.631	0.444	0.759	1.467
4	0.632	0.553	1.280	0.852	0.632	0.454	0.774	1.445
5	0.632	0.546	1.236	0.777	0.632	0.427	0.736	1.431
6	0.628	0.513	1.192	0.743	0.628	0.398	0.682	1.422
7	0.625	0.538	1.169	0.738	0.625	0.425	0.730	1.419
8	0.601	0.654	1.057	0.710	0.601	0.538	0.947	1.432
9	0.585	0.677	0.986	0.673	0.585	0.550	0.987	1.420
10	0.562	0.710	0.914	0.634	0.562	0.561	1.043	1.356
11	0.539	0.745	0.875	0.608	0.539	0.567	1.096	1.334

RP	PERCENT		INCIDENCE		DEV	D-FACT	EFF	LOSS COEFF		LOSS PARAM	
	SPAN	MEAN	SS	TOT				PROF	TOT	PROF	
1	5.00	4.1	1.2	6.5	0.371	0.705	0.205	0.117	0.031	0.018	
2	10.00	3.3	0.1	6.5	0.337	0.780	0.138	0.059	0.021	0.009	
3	20.00	3.2	-0.5	5.6	0.343	0.859	0.089	0.025	0.014	0.004	
4	30.00	3.8	-0.5	4.8	0.365	0.853	0.098	0.045	0.016	0.008	
5	38.00	4.1	-0.6	6.0	0.409	0.829	0.122	0.077	0.020	0.013	
6	46.00	4.6	-0.5	9.5	0.411	0.753	0.167	0.130	0.025	0.020	
7	50.00	4.8	-0.5	8.4	0.406	0.817	0.128	0.093	0.020	0.015	
8	70.00	6.4	0.3	5.2	0.382	0.919	0.066	0.042	0.012	0.008	
9	80.00	6.6	0.3	7.6	0.378	0.976	0.022	0.006	0.004	0.001	
10	90.00	7.3	0.7	10.4	0.379	0.978	0.022	0.016	0.004	0.003	
11	95.00	8.3	1.7	9.7	0.391	0.964	0.042	0.038	0.007	0.007	

TABLE IX. - STATOR BLADE-ELEMENT DATA

(a) Reading 724

RP	RADII		ABS BETAM		REL BETAM		TOTAL TEMP		TOTAL PRESS	
	IN	OUT	IN	OUT	IN	OUT	IN	RATIO	IN	RATIO
1	24.447	24.359	28.9	0.1	28.9	0.1	334.3	0.991	14.17	0.936
2	23.937	23.896	25.0	-2.3	25.0	-2.3	326.6	1.003	13.97	0.988
3	22.913	22.969	25.0	-3.5	25.0	-3.5	324.0	1.002	14.06	0.982
4	21.887	22.037	26.5	-3.3	26.5	-3.3	324.4	1.001	14.07	0.974
5	21.064	21.290	30.1	-1.5	30.1	-1.5	325.9	0.995	14.08	0.968
6	20.239	20.544	29.0	-4.7	29.0	-4.7	321.6	0.999	13.27	0.978
7	19.827	20.173	29.9	-4.8	29.9	-4.8	322.0	0.997	13.55	0.962
8	17.767	18.326	29.5	-3.0	29.5	-3.0	324.4	0.995	14.55	0.985
9	16.739	17.412	30.5	-3.2	30.5	-3.2	324.5	0.995	14.79	0.969
10	15.715	16.500	31.6	-2.0	31.6	-2.0	324.3	0.998	15.01	0.972
11	15.207	16.040	34.9	0.4	34.9	0.4	326.3	0.999	15.23	0.975

RP	ABS VEL		REL VEL		MERID VEL		TANG VEL		WHEEL SPEED	
	IN	OUT	IN	OUT	IN	OUT	IN	OUT	IN	OUT
1	217.4	196.0	217.4	196.0	190.4	196.0	105.0	0.2	0.	0.
2	208.8	210.8	208.8	210.8	189.3	210.6	88.2	-8.4	0.	0.
3	207.4	214.5	207.4	214.5	188.0	214.1	87.5	-13.2	0.	0.
4	210.0	214.1	210.0	214.1	187.9	213.8	93.8	-12.3	0.	0.
5	205.0	208.3	205.0	208.3	177.3	208.2	102.9	-5.5	0.	0.
6	188.6	198.3	188.6	198.3	165.0	197.6	91.3	-16.3	0.	0.
7	197.1	198.4	197.1	198.4	170.8	197.7	98.4	-16.7	0.	0.
8	236.7	213.4	236.7	213.4	206.1	213.1	116.5	-11.2	0.	0.
9	247.7	215.3	247.7	215.3	213.5	215.0	125.7	-12.1	0.	0.
10	256.3	218.5	256.3	218.5	218.2	218.4	134.5	-7.6	0.	0.
11	264.0	223.4	264.0	223.4	216.4	223.4	151.2	1.6	0.	0.

RP	ABS MACH NO		REL MACH NO		MERID MACH NO		MERID PEAK SS	
	IN	OUT	IN	OUT	IN	OUT	VEL R	MACH NO
1	0.615	0.553	0.615	0.553	0.539	0.553	1.029	0.760
2	0.597	0.602	0.597	0.602	0.541	0.601	1.113	0.625
3	0.595	0.616	0.595	0.616	0.539	0.615	1.139	0.610
4	0.602	0.615	0.602	0.615	0.539	0.614	1.138	0.663
5	0.586	0.597	0.586	0.597	0.506	0.597	1.175	0.722
6	0.540	0.569	0.540	0.569	0.472	0.567	1.198	0.626
7	0.565	0.570	0.565	0.570	0.490	0.568	1.157	0.670
8	0.686	0.615	0.686	0.615	0.597	0.614	1.034	0.724
9	0.721	0.620	0.721	0.620	0.621	0.619	1.007	0.739
10	0.749	0.629	0.749	0.629	0.637	0.629	1.001	0.749
11	0.771	0.642	0.771	0.642	0.632	0.642	1.032	0.880

RP	PERCENT	INCIDENCE		DEV	D-FACT	EFF	LOSS COEFF		LOSS PARAM	
	SPAN	MEAN	SS				TOT	PROF	TOT	PROF
1	5.00	-6.4	-13.2	8.5	0.257	0.	0.282	0.282	0.093	0.093
2	10.00	-10.0	-16.5	6.0	0.140	0.	0.054	0.054	0.017	0.017
3	20.00	-9.2	-15.4	4.3	0.115	0.	0.084	0.084	0.026	0.026
4	30.00	-7.6	-13.4	4.4	0.129	0.	0.119	0.119	0.035	0.035
5	38.00	-4.5	-9.9	6.1	0.133	0.	0.155	0.155	0.044	0.044
6	46.00	-6.4	-11.5	2.9	0.104	0.	0.123	0.123	0.034	0.034
7	50.00	-5.9	-10.8	2.8	0.149	0.	0.195	0.195	0.052	0.052
8	70.00	-9.0	-13.2	4.7	0.226	0.	0.055	0.055	0.013	0.013
9	80.00	-9.8	-13.7	4.7	0.255	0.	0.105	0.105	0.024	0.024
10	90.00	-10.7	-14.3	6.1	0.262	0.	0.089	0.089	0.019	0.019
11	95.00	-8.4	-11.8	8.5	0.267	0.	0.078	0.078	0.016	0.016

TABLE IX. - Continued.

(b) Reading 736

RP	RAD II		ABS BETAM		REL BETAM		TOTAL TEMP		TOTAL PRESS	
	IN	OUT	IN	OUT	IN	OUT	IN	RATIO	IN	RATIO
1	24.447	24.359	39.7	1.5	39.7	1.5	346.8	0.989	15.74	0.949
2	23.937	23.896	34.4	0.2	34.4	0.2	338.4	1.001	15.66	0.976
3	22.913	22.969	32.6	-2.0	32.6	-2.0	334.0	1.001	15.77	0.972
4	21.887	22.037	35.2	-0.9	35.2	-0.9	334.6	0.999	15.72	0.985
5	21.064	21.290	38.6	0.5	38.6	0.5	334.3	0.995	15.46	0.983
6	20.239	20.544	38.4	-3.2	38.4	-3.2	330.0	0.999	14.84	0.976
7	19.827	20.173	36.5	-2.9	36.5	-2.9	328.8	0.999	15.08	0.971
8	17.767	18.326	33.8	-1.7	33.8	-1.7	327.4	0.999	15.48	0.985
9	16.739	17.412	35.0	-2.1	35.0	-2.1	325.6	1.002	15.28	0.991
10	15.715	16.500	36.6	-3.1	36.6	-3.1	324.8	1.007	15.12	1.006
11	15.207	16.040	40.7	-2.0	40.7	-2.0	328.0	1.003	15.58	0.962

RP	ABS VEL		REL VEL		MERID VEL		TANG VEL		WHEEL SPEED	
	IN	OUT	IN	OUT	IN	OUT	IN	OUT	IN	OUT
1	214.4	178.1	214.4	178.1	164.9	178.0	137.0	4.6	0.	0.
2	211.2	187.1	211.2	187.1	174.2	187.1	119.4	0.5	0.	0.
3	213.8	192.9	213.8	192.9	180.2	192.8	115.1	-6.9	0.	0.
4	214.5	194.6	214.5	194.6	175.3	194.6	123.5	-3.0	0.	0.
5	205.5	184.3	205.5	184.3	160.7	184.3	128.1	1.7	0.	0.
6	195.7	172.4	195.7	172.4	153.4	172.1	121.5	-9.7	0.	0.
7	202.4	174.8	202.4	174.8	162.6	174.6	120.5	-8.8	0.	0.
8	229.4	187.7	229.4	187.7	190.6	187.6	127.6	-5.6	0.	0.
9	227.4	186.0	227.4	186.0	186.2	185.9	130.6	-6.7	0.	0.
10	229.7	182.1	229.7	182.1	184.4	181.8	137.0	-9.7	0.	0.
11	244.1	175.6	244.1	175.6	185.2	175.5	159.0	-6.1	0.	0.

RP	ABS MACH NO		REL MACH NO		MERID MACH NO		MERID PEAK SS	
	IN	OUT	IN	OUT	IN	OUT	VEL R	MACH NO
1	0.594	0.491	0.594	0.491	0.457	0.491	1.080	0.960
2	0.593	0.521	0.593	0.521	0.489	0.521	1.074	0.848
3	0.605	0.542	0.605	0.542	0.510	0.541	1.070	0.821
4	0.606	0.547	0.606	0.547	0.495	0.547	1.110	0.869
5	0.579	0.517	0.579	0.517	0.453	0.517	1.147	0.887
6	0.554	0.485	0.554	0.485	0.434	0.484	1.121	0.832
7	0.575	0.493	0.575	0.493	0.462	0.492	1.074	0.821
8	0.659	0.532	0.659	0.532	0.548	0.532	0.984	0.825
9	0.655	0.528	0.655	0.528	0.536	0.528	0.998	0.816
10	0.663	0.515	0.663	0.515	0.532	0.515	0.986	0.825
11	0.705	0.495	0.705	0.495	0.535	0.494	0.948	0.960

RP	PERCENT		INCIDENCE		DEV	D-FACT	EFF	LOSS COEFF		LOSS PARAM	
	SPAN	MEAN	SS	TOT				PROF	TOT	PROF	
1	5.00	4.4	-2.3	9.9	0.373	0.	0.240	0.240	0.079	0.079	
2	10.00	-0.5	-7.1	8.4	0.295	0.	0.116	0.116	0.037	0.037	
3	20.00	-1.7	-7.9	5.8	0.274	0.	0.129	0.129	0.040	0.040	
4	30.00	1.1	-4.7	6.8	0.266	0.	0.069	0.069	0.020	0.020	
5	38.00	4.0	-1.5	8.1	0.277	0.	0.082	0.082	0.023	0.023	
6	46.00	3.0	-2.1	4.4	0.301	0.	0.126	0.126	0.034	0.034	
7	50.00	0.7	-4.2	4.7	0.306	0.	0.144	0.144	0.038	0.038	
8	70.00	-4.7	-8.9	6.0	0.319	0.	0.059	0.059	0.014	0.014	
9	80.00	-5.3	-9.2	5.8	0.316	0.	0.036	0.036	0.008	0.008	
10	90.00	-5.7	-9.3	5.0	0.340	0.	-0.024	-0.024	-0.005	-0.005	
11	95.00	-2.7	-6.1	6.1	0.416	0.	0.136	0.136	0.028	0.028	

TABLE IX. - Continued.

(c) Reading 749

RP	RADI		ABS BETAM		REL BETAM		TOTAL TEMP		TOTAL PRESS	
	IN	OUT	IN	OUT	IN	OUT	IN	RATIO	IN	RATIO
1	24.447	24.359	47.7	3.2	47.7	3.2	362.6	0.979	17.57	0.964
2	23.937	23.896	41.1	3.2	41.1	3.2	350.3	0.999	17.18	0.988
3	22.913	22.969	38.0	-0.9	38.0	-0.9	342.3	1.000	16.94	0.990
4	21.887	22.037	39.4	0.6	39.4	0.6	340.6	0.999	16.90	0.984
5	21.064	21.290	41.4	1.3	41.4	1.3	339.5	0.998	16.59	0.978
6	20.239	20.544	41.5	-0.8	41.5	-0.8	336.3	1.001	16.31	0.965
7	19.827	20.173	41.2	-0.1	41.2	-0.1	335.3	1.001	16.28	0.968
8	17.767	18.326	42.2	1.3	42.2	1.3	331.9	0.999	16.11	0.971
9	16.739	17.412	44.1	-0.1	44.1	-0.1	327.9	1.008	15.48	1.005
10	15.715	16.500	45.4	0.1	45.4	0.1	326.2	1.019	15.20	1.030
11	15.207	16.040	48.5	1.7	48.5	1.7	331.4	1.008	16.14	0.956

RP	ABS VEL		REL VEL		MERID VEL		TANG VEL		WHEEL SPEED	
	IN	OUT	IN	OUT	IN	OUT	IN	OUT	IN	OUT
1	238.3	187.8	238.3	187.8	160.5	187.5	176.2	10.5	0.	0.
2	227.7	189.4	227.7	189.4	171.5	189.1	149.8	10.7	0.	0.
3	224.3	185.0	224.3	185.0	176.8	185.0	138.0	-2.8	0.	0.
4	222.6	177.9	222.6	177.9	172.1	177.9	141.2	1.7	0.	0.
5	218.0	166.0	218.0	166.0	163.6	166.0	144.0	3.7	0.	0.
6	212.1	154.2	212.1	154.2	158.9	154.2	140.4	-2.0	0.	0.
7	212.5	152.9	212.5	152.9	159.9	152.9	140.0	-0.4	0.	0.
8	211.1	148.6	211.1	148.6	156.3	148.5	141.8	3.3	0.	0.
9	198.4	148.2	198.4	148.2	142.4	148.2	138.2	-0.2	0.	0.
10	200.6	145.4	200.6	145.4	140.8	145.4	142.8	0.4	0.	0.
11	229.5	136.6	229.5	136.6	152.1	136.5	171.9	4.0	0.	0.

RP	ABS MACH NO		REL MACH NO		MERID MACH NO		MERID PEAK SS	
	IN	OUT	IN	OUT	IN	OUT	VEL R	MACH NO
1	0.650	0.510	0.650	0.510	0.438	0.509	1.168	1.228
2	0.631	0.519	0.631	0.519	0.475	0.518	1.103	1.046
3	0.628	0.512	0.628	0.512	0.495	0.512	1.046	0.969
4	0.625	0.493	0.625	0.493	0.483	0.493	1.034	0.985
5	0.612	0.460	0.612	0.460	0.459	0.459	1.014	0.995
6	0.597	0.427	0.597	0.427	0.448	0.427	0.970	0.960
7	0.600	0.424	0.600	0.424	0.451	0.424	0.956	0.951
8	0.598	0.414	0.598	0.414	0.443	0.414	0.950	0.926
9	0.564	0.414	0.564	0.414	0.405	0.414	1.040	0.882
10	0.572	0.404	0.572	0.404	0.401	0.404	1.033	0.888
11	0.656	0.378	0.656	0.378	0.435	0.378	0.897	1.068

RP	PERCENT		INCIDENCE		DEV	D-FACT	EFF	LOSS COEFF		LOSS PARAM	
	SPAN		MEAN	SS				TOT	PROF	TOT	PROF
1	5.00		12.4	5.6	11.6	0.441	0.	0.146	0.146	0.048	0.048
2	10.00		6.2	-0.3	11.5	0.365	0.	0.049	0.049	0.016	0.016
3	20.00		3.8	-2.5	7.0	0.369	0.	0.044	0.044	0.014	0.014
4	30.00		5.2	-0.5	8.2	0.385	0.	0.067	0.067	0.020	0.020
5	38.00		6.7	1.3	8.8	0.421	0.	0.099	0.099	0.028	0.028
6	46.00		6.1	1.0	6.8	0.455	0.	0.163	0.163	0.045	0.045
7	50.00		5.4	0.4	7.5	0.456	0.	0.150	0.150	0.040	0.040
8	70.00		3.7	-0.5	9.0	0.451	0.	0.134	0.134	0.032	0.032
9	80.00		3.8	-0.1	7.8	0.408	0.	-0.027	-0.027	-0.006	-0.006
10	90.00		3.1	-0.5	8.2	0.422	0.	-0.153	-0.153	-0.032	-0.032
11	95.00		5.2	1.7	9.8	0.551	0.	0.176	0.176	0.036	0.036

TABLE IX. - Continued.

(d) Reading 760

RP	RADII		ABS BETAM		REL BETAM		TOTAL TEMP		TOTAL PRESS	
	IN	OUT	IN	OUT	IN	OUT	IN	RATIO	IN	RATIO
1	24.447	24.359	49.2	3.5	49.2	3.5	366.4	0.978	18.01	0.962
2	23.937	23.896	42.9	4.0	42.9	4.0	353.7	1.000	17.65	0.985
3	22.913	22.969	38.6	-0.3	38.6	-0.3	344.4	1.001	17.36	0.986
4	21.887	22.037	39.9	2.0	39.9	2.0	342.3	0.999	17.25	0.979
5	21.064	21.290	42.4	1.9	42.4	1.9	341.2	0.998	16.83	0.976
6	20.239	20.544	43.8	0.1	43.8	0.1	339.0	0.999	16.51	0.966
7	19.827	20.173	44.2	1.1	44.2	1.1	338.1	0.998	16.38	0.965
8	17.767	18.326	44.7	2.7	44.7	2.7	331.7	1.003	15.92	0.993
9	16.739	17.412	46.7	1.1	46.7	1.1	328.5	1.009	15.47	1.011
10	15.715	16.500	47.8	2.3	47.8	2.3	327.4	1.019	15.34	1.029
11	15.207	16.040	51.6	3.4	51.6	3.4	332.6	1.007	16.28	0.948

RP	ABS VEL		REL VEL		MERID VEL		TANG VEL		WHEEL SPEED	
	IN	OUT	IN	OUT	IN	OUT	IN	OUT	IN	OUT
1	245.1	193.7	245.1	193.7	160.1	193.3	185.7	11.8	0.	0.
2	235.7	193.6	235.7	193.8	172.8	193.3	160.3	13.6	0.	0.
3	231.2	189.9	231.2	189.9	180.7	189.9	144.2	-1.0	0.	0.
4	227.7	180.0	227.7	180.0	174.7	179.9	146.0	6.3	0.	0.
5	221.2	167.6	221.2	167.6	163.2	167.5	149.3	5.4	0.	0.
6	213.7	152.5	213.7	152.5	154.2	152.5	147.9	0.2	0.	0.
7	212.0	146.5	212.0	146.5	152.0	146.5	147.8	2.7	0.	0.
8	200.1	129.7	200.1	129.7	142.1	129.5	140.8	6.1	0.	0.
9	193.0	130.4	193.0	130.4	132.2	130.4	140.5	2.6	0.	0.
10	198.2	124.4	198.2	124.4	133.2	124.3	146.8	5.0	0.	0.
11	227.3	109.2	227.3	109.2	141.3	109.0	178.1	6.6	0.	0.

RP	ABS MACH NO		REL MACH NO		MERID MACH NO		MERID PEAK SS	
	IN	OUT	IN	OUT	IN	OUT	VEL R	MACH NO
1	0.667	0.524	0.667	0.524	0.435	0.523	1.208	1.296
2	0.651	0.529	0.651	0.529	0.477	0.527	1.119	1.118
3	0.647	0.524	0.647	0.524	0.506	0.524	1.051	1.012
4	0.639	0.498	0.639	0.498	0.490	0.497	1.030	1.017
5	0.620	0.463	0.620	0.463	0.457	0.463	1.026	1.031
6	0.600	0.421	0.600	0.421	0.433	0.421	0.989	1.012
7	0.595	0.404	0.595	0.404	0.427	0.404	0.964	1.005
8	0.565	0.359	0.565	0.359	0.402	0.359	0.911	0.923
9	0.547	0.362	0.547	0.362	0.375	0.362	0.986	0.904
10	0.564	0.344	0.564	0.344	0.379	0.344	0.933	0.921
11	0.647	0.301	0.647	0.301	0.402	0.300	0.772	1.123

RP	PERCENT		INCIDENCE		DEV	D-FACT	EFF	LOSS COEFF		LOSS PARAM	
	SPAN	MEAN	SS	TOT				PROF	TOT	PROF	
1	5.00	13.9	7.2	11.9	0.443	0.	0.146	0.146	0.048	0.048	
2	10.00	7.9	1.4	12.3	0.378	0.	0.062	0.062	0.020	0.020	
3	20.00	4.4	-1.8	7.5	0.372	0.	0.055	0.055	0.017	0.017	
4	30.00	5.8	-0.0	9.6	0.390	0.	0.086	0.086	0.025	0.025	
5	38.00	7.8	2.4	9.5	0.426	0.	0.104	0.104	0.030	0.030	
6	46.00	8.5	3.3	7.7	0.474	0.	0.160	0.160	0.044	0.044	
7	50.00	8.4	3.4	8.7	0.491	0.	0.166	0.166	0.044	0.044	
8	70.00	6.2	2.0	10.4	0.511	0.	0.038	0.038	0.009	0.009	
9	80.00	6.4	2.6	9.0	0.482	0.	-0.062	-0.062	-0.014	-0.014	
10	90.00	5.4	1.9	10.3	0.520	0.	-0.150	-0.150	-0.032	-0.032	
11	95.00	8.2	4.8	11.5	0.670	0.	0.210	0.210	0.043	0.043	

TABLE IX. - Continued.

(e) Reading 771

RP	RADII		ABS BETAM		REL BETAM		TOTAL TEMP		TOTAL PRESS	
	IN	OUT	IN	OUT	IN	OUT	IN	RATIO	IN	RATIO
1	24.447	24.359	54.1	3.8	54.1	3.8	371.4	0.977	18.53	0.966
2	23.937	23.896	45.2	4.8	45.2	4.8	357.3	1.001	18.22	0.979
3	22.913	22.969	40.6	1.6	40.6	1.6	346.7	1.002	17.85	0.976
4	21.887	22.037	42.2	3.8	42.2	3.8	344.0	1.000	17.53	0.976
5	21.064	21.290	46.6	3.1	46.6	3.1	344.0	0.997	17.02	0.974
6	20.239	20.544	50.0	2.5	50.0	2.5	342.7	0.996	16.48	0.975
7	19.827	20.173	49.6	3.3	49.6	3.3	341.1	0.997	16.37	0.972
8	17.767	18.326	45.5	3.8	45.5	3.8	331.9	1.008	15.70	1.015
9	16.739	17.412	47.1	3.3	47.1	3.3	330.3	1.010	15.62	1.010
10	15.715	16.500	47.3	5.8	47.3	5.8	329.2	1.016	15.56	1.012
11	15.207	16.040	51.2	7.7	51.2	7.7	334.5	1.005	16.54	0.935

RP	ABS VEL		REL VEL		MERID VEL		TANG VEL		WHEEL SPEED	
	IN	OUT	IN	OUT	IN	OUT	IN	OUT	IN	OUT
1	245.4	196.6	245.4	196.6	143.9	196.2	198.8	12.9	0.	0.
2	237.6	193.1	237.6	193.1	167.4	192.4	168.6	16.1	0.	0.
3	233.7	185.6	233.7	185.6	177.5	185.5	151.9	5.0	0.	0.
4	225.6	172.5	225.6	172.5	167.2	172.1	151.4	11.5	0.	0.
5	216.2	156.2	216.2	156.2	148.4	156.0	157.2	8.3	0.	0.
6	206.9	137.8	206.9	137.8	132.9	137.7	158.6	6.0	0.	0.
7	205.2	130.8	205.2	130.8	132.9	130.6	156.4	7.4	0.	0.
8	198.8	116.4	198.8	116.4	139.4	116.2	141.7	7.8	0.	0.
9	201.3	113.5	201.3	113.5	137.0	113.4	147.4	6.5	0.	0.
10	209.8	104.0	209.8	104.0	142.3	103.4	154.2	10.5	0.	0.
11	238.4	62.4	238.4	62.4	149.3	61.9	185.8	8.4	0.	0.

RP	ABS MACH NO		REL MACH NO		MERID MACH NO		MERID PEAK SS	
	IN	OUT	IN	OUT	IN	OUT	VEL R	MACH NO
1	0.663	0.529	0.663	0.529	0.388	0.528	1.364	1.406
2	0.653	0.523	0.653	0.523	0.460	0.521	1.150	1.175
3	0.652	0.510	0.652	0.510	0.496	0.509	1.045	1.063
4	0.630	0.474	0.630	0.474	0.467	0.473	1.030	1.053
5	0.602	0.429	0.602	0.429	0.414	0.428	1.051	1.088
6	0.576	0.378	0.576	0.378	0.370	0.377	1.036	1.096
7	0.572	0.358	0.572	0.358	0.371	0.358	0.983	1.073
8	0.561	0.321	0.561	0.321	0.394	0.320	0.833	0.930
9	0.570	0.313	0.570	0.313	0.388	0.313	0.827	0.949
10	0.597	0.286	0.597	0.286	0.405	0.284	0.727	0.965
11	0.680	0.170	0.680	0.170	0.426	0.169	0.414	1.170

RP	PERCENT SPAN	INCIDENCE		DEV	D-FACT	EFF	LOSS COEFF		LOSS PARAM	
		MEAN	SS				TOT	PROF	TOT	PROF
1	5.00	18.8	12.1	12.2	0.448	0.	0.135	0.135	0.044	0.044
2	10.00	10.3	3.7	13.1	0.394	0.	0.083	0.083	0.027	0.027
3	20.00	6.3	0.1	9.4	0.400	0.	0.096	0.096	0.030	0.030
4	30.00	8.0	2.3	11.4	0.418	0.	0.104	0.104	0.031	0.031
5	38.00	12.0	6.6	10.6	0.472	0.	0.119	0.119	0.034	0.034
6	46.00	14.7	9.6	10.1	0.534	0.	0.126	0.126	0.034	0.034
7	50.00	13.8	8.9	10.9	0.555	0.	0.140	0.140	0.037	0.037
8	70.00	7.0	2.7	11.6	0.573	0.	-0.078	-0.078	-0.019	-0.019
9	80.00	6.8	2.9	11.1	0.591	0.	-0.050	-0.050	-0.011	-0.011
10	90.00	4.9	1.4	13.8	0.646	0.	-0.057	-0.057	-0.012	-0.012
11	95.00	7.9	4.5	15.8	0.886	0.	0.245	0.245	0.050	0.050

TABLE IX. - Continued.

(f) Reading 785

RP	RADII		ABS BETAM		REL BETAM		TOTAL TEMP		TOTAL PRESS	
	IN	OUT	IN	OUT	IN	OUT	IN	RATIO	IN	RATIO
1	24.447	24.359	60.3	-0.3	60.3	-0.3	364.6	0.982	16.68	0.993
2	23.937	23.896	55.3	1.1	55.3	1.1	357.7	0.991	16.58	0.997
3	22.913	22.969	46.5	4.8	46.5	4.8	347.9	0.999	16.92	0.972
4	21.887	22.037	42.9	4.7	42.9	4.7	341.8	1.001	16.87	0.975
5	21.064	21.290	44.3	3.6	44.3	3.6	341.5	0.995	16.83	0.967
6	20.239	20.544	45.6	2.7	45.6	2.7	340.2	0.994	16.56	0.961
7	19.827	20.173	45.6	2.1	45.6	2.1	339.3	0.993	16.47	0.962
8	17.767	18.326	45.3	2.0	45.3	2.0	332.4	1.000	16.04	0.986
9	16.739	17.412	47.6	1.1	47.6	1.1	330.6	1.003	15.70	0.999
10	15.715	16.500	47.9	1.8	47.9	1.8	330.1	1.008	15.81	0.999
11	15.207	16.040	49.3	3.3	49.3	3.3	333.9	1.001	16.38	0.935

RP	ABS VEL		REL VEL		MERID VEL		TANG VEL		WHEEL SPEED	
	IN	OUT	IN	OUT	IN	OUT	IN	OUT	IN	OUT
1	213.0	166.1	213.0	166.1	105.5	166.1	185.0	-1.0	0.	0.
2	211.8	162.9	211.8	162.9	120.5	162.9	174.1	3.0	0.	0.
3	219.5	162.3	219.5	162.3	151.0	161.7	159.3	13.7	0.	0.
4	223.1	160.7	223.1	160.7	163.4	160.2	151.9	13.1	0.	0.
5	224.3	155.4	224.3	155.4	160.6	155.1	156.6	9.7	0.	0.
6	222.0	143.1	222.0	143.1	155.4	142.9	158.5	6.7	0.	0.
7	221.2	139.3	221.2	139.3	154.7	139.2	158.2	5.1	0.	0.
8	212.4	128.1	212.4	128.1	149.4	128.1	150.9	4.5	0.	0.
9	211.6	126.7	211.6	126.7	142.8	126.7	156.1	2.5	0.	0.
10	221.8	120.4	221.8	120.4	148.6	120.3	164.7	3.7	0.	0.
11	240.8	89.0	240.8	89.0	156.9	88.8	182.6	5.1	0.	0.

RP	ABS MACH NO		REL MACH NO		MERID MACH NO		MERID PEAK SS VEL R MACH NO	
	IN	OUT	IN	OUT	IN	OUT	IN	OUT
1	0.575	0.447	0.575	0.447	0.285	0.447	1.575	1.356
2	0.577	0.440	0.577	0.440	0.328	0.440	1.352	1.246
3	0.609	0.443	0.609	0.443	0.419	0.442	1.071	1.115
4	0.625	0.442	0.625	0.442	0.458	0.441	0.981	1.059
5	0.629	0.428	0.629	0.428	0.450	0.428	0.966	1.084
6	0.623	0.394	0.623	0.394	0.436	0.394	0.920	1.088
7	0.622	0.384	0.622	0.384	0.435	0.384	0.900	1.079
8	0.602	0.355	0.602	0.355	0.424	0.355	0.857	0.992
9	0.601	0.352	0.601	0.352	0.406	0.352	0.887	1.009
10	0.633	0.333	0.633	0.333	0.424	0.333	0.810	1.035
11	0.688	0.244	0.688	0.244	0.448	0.244	0.566	1.139

RP	PERCENT SPAN	INCIDENCE		DEV	D-FACT	EFF	LOSS COEFF		LOSS PARAM	
		MEAN	SS				TOT	PROF	TOT	PROF
1	5.00	24.9	18.2	8.0	0.507	0.	0.036	0.036	0.012	0.012
2	10.00	20.3	13.8	9.2	0.491	0.	0.015	0.015	0.005	0.005
3	20.00	12.2	6.0	12.6	0.465	0.	0.127	0.127	0.039	0.039
4	30.00	8.7	3.0	12.3	0.463	0.	0.106	0.106	0.031	0.031
5	38.00	9.6	4.1	11.1	0.492	0.	0.143	0.143	0.041	0.041
6	46.00	10.2	5.0	10.2	0.541	0.	0.171	0.171	0.047	0.047
7	50.00	9.8	4.8	9.7	0.554	0.	0.166	0.166	0.045	0.045
8	70.00	6.7	2.5	9.7	0.559	0.	0.065	0.065	0.015	0.015
9	80.00	7.2	3.3	8.9	0.562	0.	0.005	0.005	0.001	0.001
10	90.00	5.5	1.9	9.7	0.607	0.	0.003	0.003	0.001	0.001
11	95.00	5.9	2.5	11.3	0.777	0.	0.238	0.238	0.049	0.049

TABLE IX. - Continued.

(g) Reading 796

RP	RADI I		ABS BETAM		REL BETAM		TOTAL TEMP		TOTAL PRESS	
	IN	OUT	IN	OUT	IN	OUT	IN	RATIO	IN	RATIO
1	24.447	24.359	40.8	1.7	40.8	1.7	347.3	0.988	15.42	0.954
2	23.937	23.896	34.4	-0.5	34.4	-0.5	337.1	1.001	15.46	0.974
3	22.913	22.969	33.3	-2.6	33.3	-2.6	333.0	0.998	15.47	0.975
4	21.887	22.037	35.6	-1.3	35.6	-1.3	333.3	0.995	15.41	0.978
5	21.064	21.290	39.4	0.2	39.4	0.2	333.7	0.991	15.27	0.971
6	20.239	20.544	39.3	-3.4	39.3	-3.4	329.4	0.994	14.41	0.982
7	19.827	20.173	37.1	-3.2	37.1	-3.2	328.6	0.994	14.78	0.965
8	17.767	18.326	33.3	-2.0	33.3	-2.0	327.9	0.991	15.36	0.971
9	16.739	17.412	34.4	-2.2	34.4	-2.2	326.8	0.994	15.30	0.972
10	15.715	16.500	36.7	-3.4	36.7	-3.4	328.1	0.992	15.46	0.964
11	15.207	16.040	39.1	-1.6	39.1	-1.6	331.2	0.991	15.63	0.957

RP	ABS VEL		REL VEL		MERID VEL		TANG VEL		WHEEL SPEED	
	IN	OUT	IN	OUT	IN	OUT	IN	OUT	IN	OUT
1	213.8	187.1	213.8	187.1	161.8	187.0	139.7	5.5	0.	0.
2	213.9	195.8	213.9	195.8	176.5	195.8	120.7	-1.7	0.	0.
3	216.4	199.4	216.4	199.4	180.9	199.2	118.7	-9.0	0.	0.
4	216.8	198.2	216.8	198.2	176.4	198.2	126.1	-4.4	0.	0.
5	209.4	188.8	209.4	188.8	161.7	188.8	133.0	0.5	0.	0.
6	197.1	177.3	197.1	177.3	152.5	176.9	124.8	-10.6	0.	0.
7	207.3	178.3	207.3	178.3	165.3	178.0	125.0	-9.8	0.	0.
8	245.5	191.5	245.5	191.5	205.2	191.4	134.8	-6.8	0.	0.
9	248.1	189.9	248.1	189.9	204.6	189.8	140.4	-7.4	0.	0.
10	257.3	189.5	257.3	189.5	206.2	189.2	153.9	-11.4	0.	0.
11	265.3	190.7	265.3	190.7	206.0	190.6	167.2	-5.3	0.	0.

RP	ABS MACH NO		REL MACH NO		MERID MACH NO		MERID PEAK SS	
	IN	OUT	IN	OUT	IN	OUT	VEL R	MACH NO
1	0.592	0.517	0.592	0.517	0.448	0.517	1.156	0.976
2	0.602	0.548	0.602	0.548	0.497	0.548	1.109	0.859
3	0.613	0.563	0.613	0.563	0.513	0.562	1.101	0.846
4	0.615	0.560	0.615	0.560	0.500	0.560	1.123	0.888
5	0.592	0.533	0.592	0.533	0.457	0.533	1.167	0.922
6	0.558	0.501	0.558	0.501	0.432	0.500	1.160	0.856
7	0.590	0.505	0.590	0.505	0.471	0.504	1.077	0.853
8	0.710	0.546	0.710	0.546	0.593	0.545	0.933	0.873
9	0.719	0.541	0.719	0.541	0.593	0.541	0.927	0.877
10	0.747	0.539	0.747	0.539	0.599	0.538	0.917	0.931
11	0.769	0.540	0.769	0.540	0.597	0.540	0.926	1.002

RP	PERCENT		INCIDENCE		DEV	D-FACT	EFF	LOSS COEFF		LOSS PARAM	
	SPAN	MEAN	SS	TOT				PROF	TOT	PROF	
1	5.00	5.4	-1.3	10.1	0.331	0.	0.217	0.217	0.071	0.071	
2	10.00	-0.7	-7.2	7.7	0.269	0.	0.118	0.118	0.038	0.038	
3	20.00	-1.0	-7.2	5.2	0.260	0.	0.112	0.112	0.034	0.034	
4	30.00	1.4	-4.4	6.3	0.263	0.	0.096	0.096	0.028	0.028	
5	38.00	4.8	-0.7	7.7	0.277	0.	0.136	0.136	0.039	0.039	
6	46.00	3.9	-1.3	4.1	0.287	0.	0.093	0.093	0.025	0.025	
7	50.00	1.2	-3.7	4.4	0.313	0.	0.168	0.168	0.045	0.045	
8	70.00	-5.3	-9.5	5.6	0.356	0.	0.102	0.102	0.024	0.024	
9	80.00	-5.9	-9.8	5.6	0.367	0.	0.096	0.096	0.022	0.022	
10	90.00	-5.7	-9.3	4.5	0.397	0.	0.115	0.115	0.024	0.024	
11	95.00	-4.3	-7.7	6.4	0.411	0.	0.132	0.132	0.027	0.027	

TABLE IX. - Continued.

(h) Reading 808

RP	RAD II		ABS BETAM		REL BETAM		TOTAL TEMP		TOTAL PRESS	
	IN	OUT	IN	OUT	IN	OUT	IN	RATIO	IN	RATIO
1	24.447	24.359	52.6	3.4	52.6	3.4	357.8	0.978	16.30	0.977
2	23.937	23.896	41.5	1.1	41.5	1.1	346.6	0.993	16.70	0.968
3	22.913	22.969	37.7	-1.2	37.7	-1.2	338.7	0.996	16.28	0.987
4	21.887	22.037	39.6	-0.4	39.6	-0.4	337.8	0.995	16.17	0.987
5	21.064	21.290	42.2	1.0	42.2	1.0	337.8	0.991	16.16	0.971
6	20.239	20.544	41.2	-2.1	41.2	-2.1	333.4	0.996	15.55	0.972
7	19.827	20.173	39.1	-1.7	39.1	-1.7	332.1	0.996	15.79	0.961
8	17.767	18.326	36.1	-0.0	36.1	-0.0	330.1	0.996	15.82	0.972
9	16.739	17.412	38.6	-1.4	38.6	-1.4	330.1	0.994	15.79	0.967
10	15.715	16.500	39.5	-3.3	39.5	-3.3	328.3	1.002	15.43	0.987
11	15.207	16.040	41.8	-1.7	41.8	-1.7	332.0	0.996	15.80	0.952

RP	ABS VEL		REL VEL		MERID VEL		TANG VEL		WHEEL SPEED	
	IN	OUT	IN	OUT	IN	OUT	IN	OUT	IN	OUT
1	209.2	185.2	209.2	185.2	127.0	184.8	166.3	11.1	0.	0.
2	220.2	191.0	220.2	191.0	164.8	191.0	146.0	3.6	0.	0.
3	219.7	190.4	219.7	190.4	173.9	190.3	134.2	-4.0	0.	0.
4	216.5	186.1	216.5	186.1	167.0	186.1	137.9	-1.3	0.	0.
5	215.5	176.3	215.5	176.3	159.6	176.3	144.7	3.1	0.	0.
6	208.6	165.5	208.6	165.5	157.0	165.4	137.4	-6.0	0.	0.
7	215.0	165.0	215.0	165.0	166.7	164.9	135.7	-5.0	0.	0.
8	240.2	167.8	240.2	167.8	194.2	167.8	141.3	-0.1	0.	0.
9	242.4	166.7	242.4	166.7	189.4	166.6	151.3	-3.9	0.	0.
10	242.9	161.5	242.9	161.5	187.5	161.2	154.3	-9.3	0.	0.
11	255.7	154.2	255.7	154.2	190.6	154.1	170.4	-4.5	0.	0.

RP	ABS MACH NO		REL MACH NO		MERID MACH NO		MERID PEAK SS	
	IN	OUT	IN	OUT	IN	OUT	VEL R	MACH NO
1	0.569	0.506	0.569	0.506	0.346	0.506	1.456	1.175
2	0.612	0.528	0.612	0.528	0.458	0.528	1.159	1.021
3	0.618	0.532	0.618	0.532	0.489	0.531	1.094	0.945
4	0.609	0.520	0.609	0.520	0.470	0.520	1.114	0.963
5	0.606	0.492	0.606	0.492	0.449	0.492	1.104	1.001
6	0.590	0.463	0.590	0.463	0.444	0.463	1.054	0.941
7	0.610	0.462	0.610	0.462	0.473	0.462	0.989	0.924
8	0.690	0.472	0.690	0.472	0.558	0.472	0.864	0.920
9	0.697	0.469	0.697	0.469	0.545	0.469	0.880	0.957
10	0.701	0.453	0.701	0.453	0.541	0.452	0.859	0.943
11	0.737	0.431	0.737	0.431	0.550	0.431	0.809	1.031

RP	PERCENT	INCIDENCE		DEV	D-FACT	EFF	LOSS COEFF		LOSS PARAM	
	SPAN	MEAN	SS				TOT	PROF	TOT	PROF
1	5.00	17.3	10.5	11.8	0.359	0.	0.114	0.114	0.037	0.037
2	10.00	6.5	-0.0	9.3	0.341	0.	0.143	0.143	0.046	0.046
3	20.00	3.4	-2.8	6.6	0.328	0.	0.056	0.056	0.017	0.017
4	30.00	5.4	-0.4	7.1	0.330	0.	0.058	0.058	0.017	0.017
5	38.00	7.5	2.0	8.5	0.367	0.	0.131	0.131	0.037	0.037
6	46.00	5.8	0.6	5.5	0.393	0.	0.134	0.134	0.037	0.037
7	50.00	3.3	-1.7	5.8	0.406	0.	0.177	0.177	0.047	0.047
8	70.00	-2.5	-6.7	7.6	0.440	0.	0.103	0.103	0.025	0.025
9	80.00	-1.8	-5.7	6.4	0.454	0.	0.120	0.120	0.027	0.027
10	90.00	-3.0	-6.5	4.7	0.475	0.	0.045	0.045	0.010	0.010
11	95.00	-1.6	-5.0	6.3	0.534	0.	0.159	0.159	0.033	0.033

TABLE IX. - Continued.

(i) Reading 819

RP	RAD II		ABS BETAM		REL BETAM		TOTAL TEMP		TOTAL PRESS	
	IN	OUT	IN	OUT	IN	OUT	IN	RATIO	IN	RATIO
1	24.447	24.359	54.5	3.9	54.5	3.9	362.5	0.974	16.93	0.978
2	23.937	23.896	44.2	2.0	44.2	2.0	351.0	0.990	17.19	0.966
3	22.913	22.969	39.4	-0.6	39.4	-0.6	342.1	0.997	16.78	0.983
4	21.887	22.037	40.2	0.7	40.2	0.7	339.7	0.997	16.79	0.978
5	21.064	21.290	41.8	1.6	41.8	1.6	339.4	0.995	16.69	0.969
6	20.239	20.544	42.1	-0.5	42.1	-0.5	336.3	0.998	16.27	0.961
7	19.827	20.173	41.5	-0.1	41.5	-0.1	335.1	0.998	16.28	0.955
8	17.767	18.326	41.5	1.2	41.5	1.2	332.3	0.997	16.16	0.971
9	16.739	17.412	43.8	-0.4	43.8	-0.4	330.1	1.000	15.75	0.984
10	15.715	16.500	44.4	-1.1	44.4	-1.1	328.3	1.009	15.44	1.008
11	15.207	16.040	46.7	0.6	46.7	0.6	333.2	1.000	16.06	0.950

RP	ABS VEL		REL VEL		MERID VEL		TANG VEL		WHEEL SPEED	
	IN	OUT	IN	OUT	IN	OUT	IN	OUT	IN	OUT
1	218.7	187.3	218.7	187.3	127.0	186.9	178.1	12.7	0.	0.
2	225.4	188.1	225.4	188.1	161.6	188.0	157.2	6.7	0.	0.
3	225.1	186.1	225.1	186.1	173.8	186.1	143.0	-1.9	0.	0.
4	223.6	182.5	223.6	182.5	170.7	182.5	144.5	2.1	0.	0.
5	223.2	174.4	223.2	174.4	166.3	174.3	148.9	4.8	0.	0.
6	217.3	161.8	217.3	161.8	161.3	161.8	145.6	-1.4	0.	0.
7	218.4	157.9	218.4	157.9	163.7	157.9	144.6	-0.2	0.	0.
8	223.6	148.1	223.6	148.1	167.5	148.0	148.0	3.2	0.	0.
9	218.8	146.0	218.8	146.0	157.9	146.0	151.5	-0.9	0.	0.
10	219.6	138.4	219.6	138.4	156.9	138.3	153.7	-2.6	0.	0.
11	239.9	128.2	239.9	128.2	164.6	128.2	174.6	1.4	0.	0.

RP	ABS MACH NO		REL MACH NO		MERID MACH NO		MERID PEAK SS	
	IN	OUT	IN	OUT	IN	OUT	VEL R	MACH NO
1	0.593	0.510	0.593	0.510	0.344	0.509	1.472	1.265
2	0.623	0.517	0.623	0.517	0.447	0.517	1.163	1.097
3	0.631	0.516	0.631	0.516	0.487	0.516	1.071	1.003
4	0.629	0.507	0.629	0.507	0.480	0.507	1.069	1.008
5	0.628	0.485	0.628	0.485	0.468	0.484	1.048	1.030
6	0.613	0.450	0.613	0.450	0.455	0.450	1.003	0.997
7	0.618	0.439	0.618	0.439	0.463	0.439	0.965	0.984
8	0.636	0.413	0.636	0.413	0.477	0.413	0.883	0.966
9	0.624	0.408	0.624	0.408	0.450	0.408	0.925	0.968
10	0.628	0.385	0.628	0.385	0.449	0.385	0.882	0.952
11	0.686	0.355	0.686	0.355	0.470	0.355	0.779	1.075

RP	PERCENT	INCIDENCE		DEV	D-FACT	EFF	LOSS COEFF		LOSS PARAM	
	SPAN	MEAN	SS				TOT	PROF	TOT	PROF
1	5.00	19.1	12.4	12.3	0.392	0.	0.103	0.103	0.034	0.034
2	10.00	9.2	2.6	10.2	0.381	0.	0.147	0.147	0.047	0.047
3	20.00	5.2	-1.0	7.2	0.372	0.	0.074	0.074	0.023	0.023
4	30.00	6.0	0.3	8.2	0.371	0.	0.096	0.096	0.028	0.028
5	38.00	7.1	1.7	9.1	0.401	0.	0.132	0.132	0.038	0.038
6	46.00	6.6	1.5	7.0	0.439	0.	0.173	0.173	0.047	0.047
7	50.00	5.6	0.6	7.5	0.453	0.	0.197	0.197	0.053	0.053
8	70.00	2.9	-1.3	8.9	0.491	0.	0.120	0.120	0.029	0.029
9	80.00	3.5	-0.4	7.4	0.487	0.	0.067	0.067	0.015	0.015
10	90.00	2.0	-1.6	6.9	0.517	0.	-0.032	-0.032	-0.007	-0.007
11	95.00	3.3	-0.1	8.6	0.610	0.	0.184	0.184	0.038	0.038

TABLE IX. - Continued.

(j) Reading 830

RP	RADI		ABS BETAM		REL BETAM		TOTAL TEMP		TOTAL PRESS	
	IN	OUT	IN	OUT	IN	OUT	IN	RATIO	IN	RATIO
1	24.447	24.359	55.2	1.5	55.2	1.5	361.2	0.987	16.88	0.996
2	23.937	23.896	46.5	2.3	46.5	2.3	352.7	0.999	17.22	0.977
3	22.913	22.969	41.5	2.2	41.5	2.2	344.3	1.002	17.01	0.976
4	21.887	22.037	41.1	1.6	41.1	1.6	340.8	1.000	16.97	0.978
5	21.064	21.290	42.9	2.2	42.9	2.2	340.9	0.995	16.88	0.966
6	20.239	20.544	44.0	0.9	44.0	0.9	338.8	0.995	16.55	0.955
7	19.827	20.173	44.2	1.0	44.2	1.0	338.2	0.994	16.50	0.956
8	17.767	18.326	45.3	2.0	45.3	2.0	333.2	0.997	16.15	0.975
9	16.739	17.412	47.0	1.0	47.0	1.0	329.8	1.004	15.60	1.002
10	15.715	16.500	47.4	1.1	47.4	1.1	329.0	1.011	15.59	1.007
11	15.207	16.040	49.2	2.8	49.2	2.8	333.5	1.002	16.23	0.942

RP	ABS VEL		REL VEL		MERID VEL		TANG VEL		WHEEL SPEED	
	IN	OUT	IN	OUT	IN	OUT	IN	OUT	IN	OUT
1	213.4	181.1	213.4	181.1	121.7	181.3	175.3	4.9	0.	0.
2	223.2	178.5	223.2	178.5	153.5	178.3	162.0	7.2	0.	0.
3	226.4	174.9	226.4	174.9	169.6	174.8	150.0	6.7	0.	0.
4	224.3	171.6	224.3	171.6	169.1	171.5	147.4	4.7	0.	0.
5	225.2	162.8	225.2	162.8	164.9	162.7	153.5	6.2	0.	0.
6	220.5	148.8	220.5	148.8	158.6	148.8	153.2	2.4	0.	0.
7	220.6	146.1	220.6	146.1	158.0	146.0	153.9	2.6	0.	0.
8	214.1	139.9	214.1	139.9	150.7	139.8	152.0	5.0	0.	0.
9	206.9	137.9	206.9	137.9	141.1	137.8	151.3	2.5	0.	0.
10	214.1	129.9	214.1	129.9	145.0	129.9	157.5	2.5	0.	0.
11	235.3	111.2	235.3	111.2	153.9	111.1	178.1	5.3	0.	0.

RP	ABS MACH NO		REL MACH NO		MERID MACH NO		MERID PEAK SS	
	IN	OUT	IN	OUT	IN	OUT	VEL R	MACH NO
1	0.579	0.490	0.579	0.490	0.330	0.490	1.488	1.251
2	0.615	0.486	0.615	0.486	0.423	0.485	1.162	1.132
3	0.633	0.481	0.633	0.481	0.474	0.480	1.031	1.050
4	0.630	0.474	0.630	0.474	0.475	0.474	1.014	1.028
5	0.633	0.450	0.633	0.450	0.463	0.450	0.987	1.061
6	0.620	0.411	0.620	0.411	0.446	0.411	0.938	1.049
7	0.621	0.404	0.621	0.404	0.445	0.404	0.924	1.048
8	0.606	0.389	0.606	0.389	0.427	0.389	0.928	0.999
9	0.588	0.384	0.588	0.384	0.401	0.383	0.977	0.975
10	0.611	0.360	0.611	0.360	0.414	0.360	0.896	0.987
11	0.671	0.306	0.671	0.306	0.439	0.306	0.722	1.107

RP	PERCENT		INCIDENCE		DEV	D-FACT	EFF	LOSS COEFF		LOSS PARAM	
	SPAN	MEAN	SS	TOT				PROF	TOT	PROF	
1	5.00	19.9	13.1	9.9	0.414	0.	0.018	0.018	0.006	0.006	
2	10.00	11.5	5.0	10.5	0.424	0.	0.103	0.103	0.033	0.033	
3	20.00	7.2	1.0	10.0	0.423	0.	0.104	0.104	0.032	0.032	
4	30.00	6.9	1.1	9.1	0.422	0.	0.094	0.094	0.028	0.028	
5	38.00	8.3	2.8	9.7	0.462	0.	0.142	0.142	0.040	0.040	
6	46.00	8.6	3.4	8.4	0.511	0.	0.195	0.195	0.053	0.053	
7	50.00	8.4	3.4	8.5	0.520	0.	0.192	0.192	0.051	0.051	
8	70.00	6.7	2.5	9.7	0.509	0.	0.112	0.112	0.027	0.027	
9	80.00	6.6	2.7	8.8	0.493	0.	-0.011	-0.011	-0.003	-0.003	
10	90.00	4.9	1.4	9.0	0.543	0.	-0.031	-0.031	-0.007	-0.007	
11	95.00	5.8	2.3	10.8	0.674	0.	0.222	0.222	0.045	0.045	

TABLE IX. - Continued.

(k) Reading 845

RP	RAD II		ABS BETAM		REL BETAM		TOTAL TEMP		TOTAL PRESS	
	IN	OUT	IN	OUT	IN	OUT	IN	RATIO	IN	RATIO
1	24.447	24.359	59.3	1.8	59.3	1.8	354.2	0.989	15.47	1.019
2	25.937	23.896	48.1	2.9	48.1	2.9	349.3	0.996	16.01	1.000
3	22.913	22.969	41.2	1.7	41.2	1.7	342.2	0.997	16.18	0.991
4	21.887	22.037	38.9	-0.5	38.9	-0.5	338.1	0.998	16.25	0.986
5	21.064	21.290	40.3	1.1	40.3	1.1	338.9	0.992	16.51	0.964
6	20.259	20.544	40.0	-0.7	40.0	-0.7	335.5	0.997	16.00	0.965
7	19.827	20.173	38.8	-0.8	38.8	-0.8	333.8	0.998	16.05	0.959
8	17.767	18.326	38.4	0.8	38.4	0.8	331.9	0.994	16.11	0.965
9	16.739	17.412	40.5	-0.9	40.5	-0.9	329.8	0.997	15.76	0.976
10	15.715	16.500	40.5	-2.2	40.5	-2.2	326.5	1.011	15.20	1.014
11	15.207	16.040	44.7	-1.2	44.7	-1.2	332.9	0.996	16.06	0.942

RP	ABS VEL		REL VEL		MERID VEL		TANG VEL		WHEEL SPEED	
	IN	OUT	IN	OUT	IN	OUT	IN	OUT	IN	OUT
1	182.2	171.1	182.2	171.1	93.1	171.0	156.6	5.2	0.	0.
2	201.9	176.6	201.9	176.6	134.9	176.4	150.3	8.9	0.	0.
3	214.3	180.4	214.3	180.4	161.1	180.3	141.3	5.4	0.	0.
4	218.6	179.3	218.6	179.3	170.2	179.3	137.1	-1.6	0.	0.
5	224.6	173.6	224.6	173.6	171.3	173.6	145.2	3.5	0.	0.
6	219.4	163.9	219.4	163.9	168.1	163.9	140.9	-2.1	0.	0.
7	220.9	160.7	220.9	160.7	172.1	160.7	138.5	-2.1	0.	0.
8	235.5	154.8	235.5	154.8	184.6	154.8	146.2	2.1	0.	0.
9	230.4	153.4	230.4	153.4	175.3	153.4	149.5	-2.5	0.	0.
10	226.7	146.3	226.7	146.3	172.3	146.2	147.4	-5.5	0.	0.
11	251.3	136.7	251.3	136.7	178.6	136.6	176.8	-2.9	0.	0.

RP	ABS MACH NO		REL MACH NO		MERID MACH NO		MERID PEAK SS	
	IN	OUT	IN	OUT	IN	OUT	VEL R	MACH NO
1	0.495	0.466	0.495	0.466	0.253	0.466	1.837	1.149
2	0.555	0.483	0.555	0.483	0.371	0.483	1.308	1.054
3	0.598	0.499	0.598	0.499	0.450	0.499	1.119	0.990
4	0.615	0.499	0.615	0.499	0.479	0.499	1.054	0.959
5	0.633	0.483	0.633	0.483	0.482	0.483	1.014	1.006
6	0.620	0.456	0.620	0.456	0.475	0.456	0.975	0.966
7	0.627	0.448	0.627	0.448	0.488	0.448	0.934	0.944
8	0.674	0.433	0.674	0.433	0.528	0.433	0.838	0.954
9	0.660	0.430	0.660	0.430	0.502	0.430	0.875	0.950
10	0.652	0.408	0.652	0.408	0.496	0.408	0.849	0.905
11	0.722	0.380	0.722	0.380	0.513	0.380	0.765	1.084

RP	PERCENT	INCIDENCE		DEV	D-FACT	EFF	LOSS COEFF		LOSS PARAM	
	SPAN	MEAN	SS				TOT	PROF	TOT	PROF
1	5.00	24.0	17.2	10.2	0.334	0.	-0.126	-0.126	-0.041	-0.041
2	10.00	13.1	6.6	11.2	0.351	0.	0.000	0.000	0.000	0.000
3	20.00	7.0	0.8	9.6	0.354	0.	0.040	0.040	0.012	0.012
4	30.00	4.8	-1.0	7.1	0.366	0.	0.060	0.060	0.018	0.018
5	38.00	5.7	0.2	8.7	0.405	0.	0.154	0.154	0.044	0.044
6	46.00	4.6	-0.5	6.9	0.430	0.	0.151	0.151	0.041	0.041
7	50.00	3.0	-1.9	6.9	0.442	0.	0.176	0.176	0.047	0.047
8	70.00	-0.1	-4.3	8.5	0.487	0.	0.135	0.135	0.032	0.032
9	80.00	0.2	-3.7	6.9	0.481	0.	0.094	0.094	0.021	0.021
10	90.00	-1.8	-5.4	5.9	0.494	0.	-0.055	-0.055	-0.012	-0.012
11	95.00	1.4	-2.0	6.9	0.599	0.	0.196	0.196	0.040	0.040

TABLE IX. - Continued.

(#) Reading 856

RP	RAD II		ABS BETAM		REL BETAM		TOTAL TEMP		TOTAL PRESS	
	IN	OUT	IN	OUT	IN	OUT	IN	RATIO	IN	RATIO
1	24.447	24.359	58.9	2.4	58.9	2.4	351.9	0.993	15.23	1.017
2	23.937	23.896	45.8	3.0	45.8	3.0	347.5	0.995	15.96	0.995
3	22.913	22.969	39.9	-0.1	39.9	-0.1	340.9	0.994	16.03	0.997
4	21.887	22.037	38.2	-0.5	39.2	-0.5	337.4	0.997	16.06	0.991
5	21.064	21.290	39.9	1.1	39.9	1.1	338.6	0.991	16.40	0.964
6	20.239	20.544	39.3	-1.9	39.3	-1.9	334.9	0.995	15.80	0.966
7	19.827	20.173	37.9	-1.5	37.9	-1.5	333.1	0.997	15.93	0.962
8	17.767	18.326	36.1	0.5	36.1	0.5	331.3	0.994	16.00	0.965
9	16.739	17.412	38.5	-1.0	38.5	-1.0	330.5	0.994	15.89	0.966
10	15.715	16.500	38.6	-2.7	38.6	-2.7	326.6	1.010	15.17	1.009
11	15.207	16.040	42.7	-1.4	42.7	-1.4	332.5	0.997	15.88	0.949

RP	ABS VEL		REL VEL		MERID VEL		TANG VEL		WHEEL SPEED	
	IN	OUT	IN	OUT	IN	OUT	IN	OUT	IN	OUT
1	175.3	165.4	175.3	165.4	90.5	165.3	150.2	6.9	0.	0.
2	201.8	176.6	201.8	176.6	140.8	176.4	144.6	9.2	0.	0.
3	214.1	183.1	214.1	183.1	164.4	183.1	137.2	-0.4	0.	0.
4	217.1	181.5	217.1	181.5	170.6	181.5	134.3	-1.7	0.	0.
5	224.0	174.8	224.0	174.8	171.9	174.7	143.6	3.3	0.	0.
6	218.4	165.5	218.4	165.5	169.0	165.4	138.3	-5.5	0.	0.
7	221.4	165.5	221.4	165.5	174.7	165.4	136.1	-4.4	0.	0.
8	243.0	167.6	243.0	167.6	196.3	167.6	143.2	1.5	0.	0.
9	242.1	166.3	242.1	166.3	189.6	166.2	150.6	-3.0	0.	0.
10	235.8	160.2	235.8	160.2	184.1	160.0	147.2	-7.6	0.	0.
11	256.3	152.2	256.3	152.2	188.3	152.1	173.9	-3.6	0.	0.

RP	ABS MACH NO		REL MACH NO		MERID MACH NO		MERID PEAK SS	
	IN	OUT	IN	OUT	IN	OUT	VEL R	MACH NO
1	0.477	0.451	0.477	0.451	0.246	0.450	1.827	1.100
2	0.557	0.485	0.557	0.485	0.388	0.484	1.253	1.012
3	0.599	0.509	0.599	0.509	0.460	0.509	1.114	0.962
4	0.611	0.506	0.611	0.506	0.480	0.506	1.064	0.940
5	0.631	0.487	0.631	0.487	0.484	0.487	1.017	0.995
6	0.618	0.462	0.618	0.462	0.478	0.462	0.978	0.948
7	0.629	0.463	0.629	0.463	0.496	0.463	0.947	0.928
8	0.698	0.471	0.698	0.471	0.564	0.471	0.854	0.933
9	0.696	0.468	0.696	0.468	0.545	0.468	0.877	0.954
10	0.680	0.449	0.680	0.449	0.531	0.448	0.869	0.899
11	0.739	0.425	0.739	0.425	0.542	0.424	0.808	1.060

RP	PERCENT		INCIDENCE		DEV	D-FACT	EFF	LOSS COEFF		LOSS PARAM	
	SPAN	MEAN	SS	TOT				PROF	TOT	PROF	
1	5.00	23.6	16.9	10.8	0.325	0.	-0.118	-0.118	-0.039	-0.039	
2	10.00	10.8	4.3	11.3	0.341	0.	0.027	0.027	0.009	0.009	
3	20.00	5.6	-0.6	7.7	0.343	0.	0.014	0.014	0.004	0.004	
4	30.00	4.1	-1.7	7.1	0.348	0.	0.039	0.039	0.012	0.012	
5	38.00	5.3	-0.2	8.7	0.397	0.	0.152	0.152	0.043	0.043	
6	46.00	4.0	-1.2	5.7	0.421	0.	0.148	0.148	0.040	0.040	
7	50.00	2.1	-2.9	6.1	0.421	0.	0.162	0.162	0.043	0.043	
8	70.00	-2.4	-6.6	8.2	0.448	0.	0.124	0.124	0.030	0.030	
9	80.00	-1.8	-5.7	6.8	0.454	0.	0.124	0.124	0.028	0.028	
10	90.00	-3.7	-7.3	5.3	0.457	0.	-0.034	-0.034	-0.007	-0.007	
11	95.00	-0.6	-4.0	6.8	0.545	0.	0.167	0.167	0.034	0.034	

TABLE IX. - Continued.

(m) Reading 867

RP	RADII		ABS BETAM		REL BETAM		TOTAL TEMP		TOTAL PRESS	
	IN	OUT	IN	OUT	IN	OUT	IN	RATIO	IN	RATIO
1	24.447	24.359	58.2	2.4	58.2	2.4	347.9	0.994	14.72	1.021
2	23.937	23.896	41.9	1.8	41.9	1.8	342.7	0.996	15.62	0.990
3	22.913	22.969	36.7	-1.0	36.7	-1.0	337.4	0.995	15.63	1.000
4	21.887	22.037	36.4	-0.8	36.4	-0.8	335.5	0.997	15.76	0.990
5	21.064	21.290	39.1	0.9	39.1	0.9	337.2	0.989	16.01	0.965
6	20.239	20.544	38.3	-2.3	38.3	-2.3	333.2	0.993	15.37	0.969
7	19.827	20.173	36.4	-2.0	36.4	-2.0	331.5	0.995	15.59	0.961
8	17.767	18.326	34.1	-1.0	34.1	-1.0	330.2	0.992	15.80	0.964
9	16.739	17.412	36.5	-1.3	36.5	-1.3	329.9	0.991	15.74	0.966
10	15.715	16.500	37.0	-3.7	37.0	-3.7	326.6	1.005	15.12	1.000
11	15.207	16.040	41.1	-1.9	41.1	-1.9	331.8	0.995	15.60	0.962

RP	ABS VEL		REL VEL		MERID VEL		TANG VEL		WHEEL SPEED	
	IN	OUT	IN	OUT	IN	OUT	IN	OUT	IN	OUT
1	165.7	166.7	165.7	166.7	87.2	166.6	140.9	7.0	0.	0.
2	199.5	179.5	199.5	179.5	148.4	179.4	133.3	5.6	0.	0.
3	214.3	186.9	214.3	186.9	171.8	186.8	128.1	-3.2	0.	0.
4	217.2	186.7	217.2	186.7	174.7	186.6	129.0	-2.6	0.	0.
5	222.4	179.2	222.4	179.2	172.7	179.2	140.2	2.9	0.	0.
6	216.0	169.8	216.0	169.8	169.5	169.7	134.0	-6.8	0.	0.
7	221.3	170.2	221.3	170.2	178.2	170.1	131.2	-5.8	0.	0.
8	249.0	179.1	249.0	179.1	206.2	179.0	139.7	-3.0	0.	0.
9	249.6	177.3	249.6	177.3	200.6	177.2	148.6	-4.0	0.	0.
10	244.0	173.4	244.0	173.4	194.9	173.1	146.7	-11.1	0.	0.
11	258.8	168.9	258.8	168.9	195.0	168.8	170.0	-5.6	0.	0.

RP	ABS MACH NO		REL MACH NO		MERID MACH NO		MERID PEAK SS	
	IN	OUT	IN	OUT	IN	OUT	VEL R	MACH NO
1	0.452	0.457	0.452	0.457	0.238	0.456	1.910	1.032
2	0.554	0.496	0.554	0.496	0.412	0.496	1.208	0.934
3	0.603	0.523	0.603	0.523	0.483	0.522	1.088	0.905
4	0.613	0.523	0.613	0.523	0.493	0.523	1.068	0.906
5	0.628	0.502	0.628	0.502	0.488	0.502	1.037	0.972
6	0.612	0.476	0.612	0.476	0.480	0.476	1.002	0.920
7	0.630	0.478	0.630	0.478	0.507	0.478	0.955	0.896
8	0.718	0.506	0.718	0.506	0.595	0.506	0.868	0.908
9	0.720	0.501	0.720	0.501	0.579	0.501	0.884	0.938
10	0.706	0.489	0.706	0.489	0.564	0.488	0.888	0.888
11	0.747	0.474	0.747	0.474	0.563	0.474	0.865	1.029

RP	PERCENT	INCIDENCE		DEV	D-FACT	EFF	LOSS COEFF		LOSS PARAM	
	SPAN	MEAN	SS				TOT	PROF	TOT	PROF
1	5.00	22.9	16.2	10.9	0.260	0.	-0.161	-0.161	-0.053	-0.053
2	10.00	7.0	0.4	10.1	0.307	0.	0.051	0.051	0.016	0.016
3	20.00	2.5	-3.7	6.9	0.317	0.	0.001	0.001	0.000	0.000
4	30.00	2.3	-3.4	6.8	0.319	0.	0.046	0.046	0.014	0.014
5	38.00	4.4	-1.0	8.5	0.369	0.	0.149	0.149	0.042	0.042
6	46.00	3.0	-2.1	5.3	0.391	0.	0.141	0.141	0.038	0.038
7	50.00	0.6	-4.4	5.6	0.395	0.	0.168	0.168	0.045	0.045
8	70.00	-4.4	-8.6	6.8	0.416	0.	0.124	0.124	0.030	0.030
9	80.00	-3.8	-7.6	6.6	0.425	0.	0.117	0.117	0.027	0.027
10	90.00	-5.4	-9.0	4.4	0.423	0.	-0.001	-0.001	-0.000	-0.000
11	95.00	-2.2	-5.7	6.2	0.483	0.	0.123	0.123	0.025	0.025

TABLE IX. - Continued.

(n) Reading 884

RP	RADII		ABS BETAM		REL BETAM		TOTAL TEMP		TOTAL	PRESS
	IN	OUT	IN	OUT	IN	OUT	IN	RATIO	IN	RATIO
1	24.447	24.359	57.0	1.8	57.0	1.8	343.4	0.992	14.03	1.024
2	23.937	23.896	37.8	0.6	37.8	0.6	339.4	0.993	15.27	0.977
3	22.913	22.969	32.2	-2.2	32.2	-2.2	333.5	0.996	15.24	0.988
4	21.887	22.037	33.2	-1.1	33.2	-1.1	333.1	0.997	15.43	0.983
5	21.064	21.290	37.0	0.4	37.0	0.4	335.7	0.987	15.62	0.960
6	20.239	20.544	36.9	-2.9	36.9	-2.9	331.3	0.991	14.71	0.975
7	19.827	20.173	35.1	-2.8	35.1	-2.8	330.2	0.992	15.04	0.959
8	17.767	18.326	31.8	-2.0	31.8	-2.0	328.2	0.992	15.46	0.973
9	16.739	17.412	33.3	-2.0	33.3	-2.0	327.6	0.993	15.37	0.975
10	15.715	16.500	35.2	-3.3	35.2	-3.3	327.1	0.996	15.31	0.977
11	15.207	16.040	39.7	-1.6	39.7	-1.6	331.2	0.992	15.43	0.971

RP	ABS VEL		REL VEL		MERID VEL		TANG VEL		WHEEL SPEED	
	IN	OUT	IN	OUT	IN	OUT	IN	OUT	IN	OUT
1	153.7	169.5	153.7	169.5	83.8	169.5	128.9	5.3	0.	0.
2	202.2	186.4	202.2	186.4	159.8	186.4	123.9	2.1	0.	0.
3	219.2	195.8	219.2	195.8	185.6	195.7	116.7	-7.4	0.	0.
4	222.2	196.9	222.2	196.9	185.8	196.9	121.8	-3.9	0.	0.
5	224.2	189.9	224.2	189.9	179.0	189.9	135.0	1.5	0.	0.
6	212.7	179.0	212.7	179.0	170.0	178.8	127.8	-9.1	0.	0.
7	221.0	179.8	221.0	179.8	180.8	179.6	127.0	-8.8	0.	0.
8	253.2	191.6	253.2	191.6	215.3	191.5	133.3	-6.5	0.	0.
9	255.1	188.8	255.1	188.8	213.2	188.7	140.1	-6.5	0.	0.
10	256.8	187.6	256.8	187.6	209.9	187.3	148.0	-10.6	0.	0.
11	263.2	188.0	263.2	188.0	202.4	187.9	168.2	-5.2	0.	0.

RP	ABS MACH NO		REL MACH NO		MERID MACH NO		MERID PEAK SS	
	IN	OUT	IN	OUT	IN	OUT	VEL R	MACH NO
1	0.421	0.468	0.421	0.468	0.229	0.468	2.023	0.940
2	0.565	0.520	0.565	0.520	0.446	0.520	1.167	0.873
3	0.622	0.552	0.622	0.552	0.526	0.552	1.054	0.835
4	0.631	0.556	0.631	0.556	0.528	0.555	1.059	0.862
5	0.635	0.535	0.635	0.535	0.507	0.535	1.061	0.939
6	0.604	0.505	0.604	0.505	0.483	0.505	1.051	0.878
7	0.630	0.508	0.630	0.508	0.516	0.508	0.993	0.869
8	0.734	0.545	0.734	0.545	0.624	0.545	0.889	0.859
9	0.741	0.537	0.741	0.537	0.619	0.537	0.885	0.871
10	0.747	0.533	0.747	0.533	0.610	0.532	0.892	0.887
11	0.762	0.532	0.762	0.532	0.586	0.532	0.928	1.013

RP	PERCENT	INCIDENCE		DEV	D-FACT	EFF	LOSS COEFF		LOSS PARAM	
	SPAN	MEAN	SS				TOT	PROF	TOT	PROF
1	5.00	21.7	14.9	10.2	0.161	0.	-0.208	-0.208	-0.068	-0.068
2	10.00	2.8	-3.7	8.9	0.272	0.	0.119	0.119	0.038	0.038
3	20.00	-2.1	-8.3	5.7	0.282	0.	0.053	0.053	0.016	0.016
4	30.00	-0.9	-6.7	6.5	0.280	0.	0.073	0.073	0.022	0.022
5	38.00	2.4	-3.0	8.0	0.322	0.	0.168	0.168	0.048	0.048
6	46.00	1.6	-3.6	4.7	0.333	0.	0.115	0.115	0.031	0.031
7	50.00	-0.7	-5.7	4.8	0.350	0.	0.176	0.176	0.047	0.047
8	70.00	-6.7	-11.0	5.8	0.374	0.	0.091	0.091	0.022	0.022
9	80.00	-7.0	-10.9	5.9	0.387	0.	0.083	0.083	0.019	0.019
10	90.00	-7.2	-10.7	4.8	0.398	0.	0.073	0.073	0.015	0.015
11	95.00	-3.6	-7.0	6.5	0.418	0.	0.090	0.090	0.018	0.018

TABLE IX. - Continued.

(o) Reading 895

RP	RAD II		ABS BETAM		REL BETAM		TOTAL TEMP		TOTAL PRESS	
	IN	OUT	IN	OUT	IN	OUT	IN	RATIO	IN	RATIO
1	24.447	24.359	41.1	0.0	41.1	0.0	337.2	0.987	13.53	0.983
2	23.937	23.896	30.5	-1.4	30.5	-1.4	330.8	0.996	14.25	0.980
3	22.913	22.969	27.6	-3.3	27.6	-3.3	327.3	0.996	14.46	0.968
4	21.887	22.037	28.6	-2.7	28.6	-2.7	327.1	0.997	14.53	0.965
5	21.064	21.290	32.8	-1.0	32.8	-1.0	329.6	0.989	14.72	0.951
6	20.239	20.544	33.7	-3.9	33.7	-3.9	325.2	0.993	13.47	0.986
7	19.827	20.173	32.6	-4.3	32.6	-4.3	325.3	0.990	13.88	0.959
8	17.767	18.326	29.9	-3.0	29.9	-3.0	327.4	0.986	14.97	0.957
9	16.739	17.412	30.4	-3.3	30.4	-3.3	325.8	0.990	15.08	0.958
10	15.715	16.500	33.0	-2.4	33.0	-2.4	327.2	0.988	15.30	0.955
11	15.207	16.040	36.3	0.1	36.3	0.1	329.8	0.989	15.18	0.974

RP	ABS VEL		REL VEL		MERID VEL		TANG VEL		WHEEL SPEED	
	IN	OUT	IN	OUT	IN	OUT	IN	OUT	IN	OUT
1	172.7	184.7	172.7	184.7	130.1	184.7	113.6	0.1	0.	0.
2	199.9	203.6	199.9	203.6	172.3	203.6	101.3	-5.0	0.	0.
3	214.8	211.0	214.8	211.0	190.3	210.7	99.5	-12.0	0.	0.
4	219.3	211.6	219.3	211.6	192.6	211.4	104.9	-10.1	0.	0.
5	215.9	207.2	215.9	207.2	181.4	207.2	116.9	-3.6	0.	0.
6	196.9	196.0	196.9	196.0	163.8	195.5	109.2	-13.5	0.	0.
7	208.1	195.2	208.1	195.2	175.2	194.7	112.2	-14.5	0.	0.
8	259.3	209.3	259.3	209.3	224.8	209.1	129.3	-11.0	0.	0.
9	265.7	211.5	265.7	211.5	229.3	211.1	134.3	-12.2	0.	0.
10	272.8	213.8	272.8	213.8	228.7	213.7	148.7	-8.9	0.	0.
11	273.5	217.8	273.5	217.8	220.3	217.8	162.0	0.3	0.	0.

RP	ABS MACH NO		REL MACH NO		MERID MACH NO		MERID PEAK SS	
	IN	OUT	IN	OUT	IN	OUT	VEL R	MACH NO
1	0.480	0.519	0.480	0.519	0.361	0.519	1.420	0.798
2	0.566	0.578	0.566	0.578	0.488	0.578	1.181	0.730
3	0.614	0.604	0.614	0.604	0.544	0.603	1.107	0.718
4	0.628	0.606	0.628	0.606	0.552	0.605	1.097	0.749
5	0.615	0.592	0.615	0.592	0.517	0.592	1.142	0.820
6	0.562	0.561	0.562	0.561	0.467	0.560	1.193	0.753
7	0.596	0.559	0.596	0.559	0.502	0.558	1.111	0.768
8	0.755	0.602	0.755	0.602	0.654	0.601	0.930	0.817
9	0.778	0.609	0.778	0.609	0.671	0.608	0.921	0.786
10	0.799	0.616	0.799	0.616	0.670	0.615	0.934	0.868
11	0.798	0.625	0.798	0.625	0.643	0.625	0.989	0.958

RP	PERCENT		INCIDENCE		DEV	D-FACT	EFF	LOSS COEFF		LOSS PARAM	
	SPAN	MEAN	SS	TOT				PROF	TOT	PROF	
1	5.00	5.9	-0.9	8.5	0.147	0.	0.115	0.115	0.038	0.038	
2	10.00	-4.5	-11.1	6.8	0.153	0.	0.105	0.105	0.034	0.034	
3	20.00	-6.6	-12.8	4.6	0.178	0.	0.143	0.143	0.044	0.044	
4	30.00	-5.6	-11.3	4.9	0.190	0.	0.149	0.149	0.044	0.044	
5	38.00	-1.8	-7.3	6.6	0.198	0.	0.217	0.217	0.062	0.062	
6	46.00	-1.7	-6.8	3.7	0.174	0.	0.071	0.071	0.019	0.019	
7	50.00	-3.2	-8.2	3.3	0.224	0.	0.194	0.194	0.052	0.052	
8	70.00	-8.6	-12.8	4.7	0.321	0.	0.137	0.137	0.033	0.033	
9	80.00	-9.9	-13.8	4.6	0.327	0.	0.128	0.128	0.029	0.029	
10	90.00	-9.3	-12.9	5.7	0.336	0.	0.132	0.132	0.028	0.028	
11	95.00	-7.0	-10.4	8.2	0.321	0.	0.075	0.075	0.015	0.015	

TABLE IX. - Continued.

(p) Reading 916

RP	RADI		ABS BETAM		REL BETAM		TOTAL TEMP		TOTAL PRESS	
	IN	OUT	IN	OUT	IN	OUT	IN	RATIO	IN	RATIO
1	24.447	24.359	55.2	4.2	55.2	4.2	370.2	0.978	18.20	0.952
2	23.937	23.896	47.1	4.3	47.1	4.3	356.4	1.000	17.96	0.969
3	22.913	22.969	42.5	1.8	42.5	1.8	347.8	1.000	17.78	0.963
4	21.887	22.037	42.8	3.5	42.8	3.5	344.8	0.999	17.58	0.964
5	21.064	21.290	46.8	3.2	46.8	3.2	345.2	0.994	17.29	0.962
6	20.239	20.544	50.4	2.9	50.4	2.9	344.1	0.994	16.67	0.974
7	19.827	20.173	50.3	3.4	50.3	3.4	342.7	0.994	16.57	0.977
8	17.767	18.326	46.5	3.8	46.5	3.8	333.5	1.007	15.93	1.012
9	16.739	17.412	47.7	3.1	47.7	3.1	331.7	1.007	15.80	1.007
10	15.715	16.500	47.3	6.6	47.3	6.6	330.8	1.014	15.85	0.997
11	15.207	16.040	49.4	10.2	49.4	10.2	335.6	1.005	16.65	0.937

RP	ABS VEL		REL VEL		MERID VEL		TANG VEL		WHEEL SPEED	
	IN	OUT	IN	OUT	IN	OUT	IN	OUT	IN	OUT
1	237.1	178.2	237.1	178.2	135.3	177.7	194.7	13.0	0.	0.
2	230.6	176.9	230.6	176.9	157.1	176.4	168.9	13.3	0.	0.
3	230.9	171.7	230.9	171.7	170.2	171.7	156.1	5.4	0.	0.
4	227.2	165.6	227.2	165.6	166.6	165.3	154.4	10.0	0.	0.
5	222.3	153.1	222.3	153.1	152.2	152.8	162.0	8.6	0.	0.
6	213.6	141.6	213.6	141.6	136.2	141.5	164.5	7.2	0.	0.
7	212.2	137.4	212.2	137.4	135.6	137.1	163.2	8.2	0.	0.
8	205.6	128.4	205.6	128.4	141.5	128.1	149.2	8.5	0.	0.
9	208.3	120.4	208.3	120.4	140.2	120.2	154.0	6.6	0.	0.
10	219.3	110.9	219.3	110.9	148.7	110.2	161.1	12.8	0.	0.
11	243.4	65.3	243.4	65.3	158.4	64.3	184.8	11.6	0.	0.

RP	ABS MACH NO		REL MACH NO		MERID MACH NO		MERID PEAK SS	
	IN	OUT	IN	OUT	IN	OUT	VEL R	MACH NO
1	0.639	0.478	0.639	0.478	0.365	0.477	1.314	1.384
2	0.634	0.478	0.634	0.478	0.432	0.477	1.123	1.180
3	0.643	0.470	0.643	0.470	0.474	0.469	1.009	1.092
4	0.635	0.455	0.635	0.455	0.465	0.454	0.992	1.075
5	0.619	0.419	0.619	0.419	0.424	0.419	1.004	1.123
6	0.594	0.388	0.594	0.388	0.379	0.388	1.038	1.138
7	0.592	0.377	0.592	0.377	0.378	0.376	1.011	1.124
8	0.581	0.354	0.581	0.354	0.399	0.353	0.906	0.984
9	0.590	0.332	0.590	0.332	0.397	0.332	0.857	0.995
10	0.625	0.305	0.625	0.305	0.424	0.303	0.741	1.011
11	0.694	0.178	0.694	0.178	0.452	0.175	0.406	1.153

RP	PERCENT SPAN		INCIDENCE MEAN SS		DEL	D-FACT	EFF	LOSS COEFF		LOSS PARAM	
	SPAN	MEAN	SS	SS				TOT	PROF	TOT	PROF
1	5.00	19.9	13.2	12.7	0.501	0.	0.201	0.201	0.066	0.066	
2	10.00	12.1	5.6	12.6	0.451	0.	0.132	0.132	0.042	0.042	
3	20.00	8.4	2.1	9.7	0.457	0.	0.154	0.154	0.048	0.048	
4	30.00	8.7	3.0	11.1	0.458	0.	0.150	0.150	0.044	0.044	
5	38.00	12.2	6.8	10.8	0.507	0.	0.168	0.168	0.048	0.048	
6	46.00	15.0	9.9	10.5	0.537	0.	0.121	0.121	0.033	0.033	
7	50.00	14.5	9.6	11.1	0.547	0.	0.111	0.111	0.030	0.030	
8	70.00	8.1	3.9	11.6	0.537	0.	-0.059	-0.059	-0.014	-0.014	
9	80.00	7.4	3.5	11.0	0.579	0.	-0.033	-0.033	-0.008	-0.008	
10	90.00	5.0	1.4	14.7	0.634	0.	0.011	0.011	0.002	0.002	
11	95.00	6.1	2.7	18.3	0.873	0.	0.230	0.230	0.046	0.046	

TABLE IX. - Continued.

(q) Reading 927

RP	RADII		ABS BETAM		REL BETAM		TOTAL TEMP		TOTAL PRESS	
	IN	OUT	IN	OUT	IN	OUT	IN	RATIO	IN	RATIO
1	24.447	24.359	50.6	3.6	50.6	3.6	365.3	0.986	17.68	0.955
2	23.937	23.896	44.4	3.1	44.4	3.1	353.0	0.999	17.43	0.975
3	22.913	22.969	40.8	-0.0	40.8	-0.0	344.0	1.001	17.09	0.979
4	21.887	22.037	40.5	1.3	40.5	1.3	340.9	1.000	17.04	0.973
5	21.064	21.290	42.4	2.1	42.4	2.1	340.8	0.997	16.90	0.967
6	20.239	20.544	43.3	1.1	43.3	1.1	338.6	0.998	16.59	0.953
7	19.827	20.173	43.6	1.6	43.6	1.6	337.8	0.997	16.47	0.954
8	17.767	18.326	44.5	2.0	44.5	2.0	332.4	0.999	16.07	0.977
9	16.739	17.412	46.5	0.8	46.5	0.8	329.3	1.005	15.61	0.996
10	15.715	16.500	47.1	2.0	47.1	2.0	328.4	1.014	15.50	1.009
11	15.207	16.040	49.2	3.2	49.2	3.2	333.5	1.003	16.31	0.938

RP	ABS VEL		REL VEL		MERID VEL		TANG VEL		WHEEL SPEED	
	IN	OUT	IN	OUT	IN	OUT	IN	OUT	IN	OUT
1	235.9	187.9	235.9	187.9	149.6	187.5	182.3	11.7	0.	0.
2	228.7	188.2	228.7	188.2	163.3	187.9	160.1	10.1	0.	0.
3	225.0	183.9	225.0	183.9	170.3	183.9	147.0	-0.1	0.	0.
4	222.8	177.3	222.8	177.3	169.4	177.2	144.8	4.1	0.	0.
5	222.6	169.5	222.6	169.5	164.5	169.4	150.1	6.2	0.	0.
6	217.0	155.6	217.0	155.6	157.8	155.6	148.9	2.9	0.	0.
7	215.4	150.4	215.4	150.4	155.9	150.3	148.6	4.1	0.	0.
8	206.1	139.0	206.1	139.0	146.9	138.9	144.5	4.7	0.	0.
9	199.3	135.9	199.3	135.9	137.2	135.9	144.5	1.8	0.	0.
10	205.6	128.9	205.6	128.9	140.0	128.8	150.6	4.6	0.	0.
11	231.2	114.7	231.2	114.7	151.0	114.5	175.2	6.4	0.	0.

RP	ABS MACH NO		REL MACH NO		MERID MACH NO		MERID PEAK SS	
	IN	OUT	IN	OUT	IN	OUT	VEL R	MACH NO
1	0.640	0.507	0.640	0.507	0.406	0.506	1.253	1.277
2	0.631	0.513	0.631	0.513	0.451	0.512	1.151	1.118
3	0.629	0.507	0.629	0.507	0.476	0.507	1.080	1.031
4	0.625	0.491	0.625	0.491	0.475	0.490	1.047	1.011
5	0.625	0.469	0.625	0.469	0.461	0.469	1.030	1.038
6	0.610	0.430	0.610	0.430	0.443	0.430	0.986	1.020
7	0.606	0.416	0.606	0.416	0.439	0.416	0.964	1.012
8	0.583	0.386	0.583	0.386	0.415	0.386	0.945	0.948
9	0.565	0.378	0.565	0.378	0.389	0.378	0.990	0.930
10	0.585	0.357	0.585	0.357	0.398	0.357	0.920	0.943
11	0.659	0.316	0.659	0.316	0.430	0.316	0.759	1.091

RP	PERCENT	INCIDENCE		DEV	D-FACT	EFF	LOSS COEFF		LOSS PARAM	
	SPAN	MEAN	SS				TOT	PROF	TOT	PROF
1	5.00	15.4	8.6	12.1	0.441	0.	0.186	0.186	0.061	0.061
2	10.00	9.5	3.0	11.4	0.389	0.	0.106	0.106	0.034	0.034
3	20.00	6.6	0.4	7.9	0.384	0.	0.091	0.091	0.028	0.028
4	30.00	6.4	0.7	9.0	0.390	0.	0.118	0.118	0.035	0.035
5	38.00	7.8	2.3	9.7	0.421	0.	0.144	0.144	0.041	0.041
6	46.00	8.0	2.9	8.7	0.466	0.	0.210	0.210	0.057	0.057
7	50.00	7.9	2.9	9.2	0.480	0.	0.209	0.209	0.056	0.056
8	70.00	6.1	1.8	9.7	0.486	0.	0.112	0.112	0.027	0.027
9	80.00	6.2	2.3	8.7	0.476	0.	0.022	0.022	0.005	0.005
10	90.00	4.8	1.2	10.1	0.520	0.	-0.045	-0.045	-0.009	-0.009
11	95.00	5.9	2.5	11.3	0.649	0.	0.247	0.247	0.050	0.050

TABLE IX. - Continued.

(r) Reading 938

RP	RADII		ABS BETAM		REL BETAM		TOTAL TEMP		TOTAL PRESS	
	IN	OUT	IN	OUT	IN	OUT	IN	RATIO	IN	RATIO
1	24.447	24.359	49.4	3.1	49.4	3.1	358.1	0.988	16.69	0.953
2	23.937	23.896	42.9	2.0	42.9	2.0	347.7	0.998	16.64	0.975
3	22.913	22.969	39.7	-0.6	39.7	-0.6	340.7	0.998	16.51	0.982
4	21.887	22.037	39.8	-0.3	39.8	-0.3	338.8	0.998	16.49	0.979
5	21.064	21.290	41.5	1.3	41.5	1.3	338.3	0.997	16.45	0.973
6	20.239	20.544	40.7	-1.4	40.7	-1.4	334.6	1.001	16.03	0.965
7	19.827	20.173	39.7	-1.0	39.7	-1.0	333.5	1.000	16.16	0.956
8	17.767	18.326	38.7	0.8	38.7	0.8	331.1	0.998	16.07	0.969
9	16.739	17.412	41.0	-0.6	41.0	-0.6	329.0	1.001	15.67	0.981
10	15.715	16.500	41.4	-1.8	41.4	-1.8	327.2	1.010	15.35	1.003
11	15.207	16.040	44.1	0.7	44.1	0.7	332.2	1.001	16.08	0.940

RP	ABS VEL		REL VEL		MERID VEL		TANG VEL		WHEEL SPEED	
	IN	OUT	IN	OUT	IN	OUT	IN	OUT	IN	OUT
1	216.0	175.7	216.0	175.7	140.6	175.5	163.9	9.6	0.	0.
2	214.3	183.9	214.3	183.9	157.0	183.8	145.8	6.3	0.	0.
3	215.0	186.3	215.0	186.3	165.4	186.3	137.4	-2.0	0.	0.
4	215.6	185.8	215.6	183.8	165.6	183.8	138.1	-1.0	0.	0.
5	215.4	177.8	215.4	177.8	161.3	177.8	142.6	4.0	0.	0.
6	210.3	167.1	210.3	167.1	159.4	167.0	137.2	-4.1	0.	0.
7	214.1	164.8	214.1	164.8	164.7	164.8	136.9	-2.8	0.	0.
8	224.7	159.2	224.7	159.2	175.4	159.2	140.5	2.2	0.	0.
9	218.8	156.4	218.8	156.4	165.1	156.4	143.5	-1.7	0.	0.
10	219.9	150.4	219.9	150.4	164.9	150.3	145.5	-4.7	0.	0.
11	242.4	140.6	242.4	140.6	174.1	140.6	168.6	1.7	0.	0.

RP	ABS MACH NO		REL MACH NO		MERID MACH NO		MERID PEAK SS	
	IN	OUT	IN	OUT	IN	OUT	VEL R	MACH NO
1	0.589	0.477	0.589	0.477	0.383	0.476	1.248	1.148
2	0.593	0.505	0.593	0.505	0.435	0.505	1.171	1.019
3	0.602	0.517	0.602	0.517	0.463	0.517	1.126	0.964
4	0.605	0.512	0.605	0.512	0.465	0.512	1.110	0.965
5	0.605	0.495	0.605	0.495	0.453	0.495	1.102	0.987
6	0.593	0.465	0.593	0.465	0.450	0.465	1.048	0.940
7	0.606	0.460	0.606	0.460	0.466	0.460	1.001	0.932
8	0.641	0.446	0.641	0.446	0.500	0.446	0.908	0.916
9	0.625	0.438	0.625	0.438	0.472	0.438	0.947	0.912
10	0.630	0.420	0.630	0.420	0.473	0.420	0.912	0.894
11	0.695	0.390	0.695	0.390	0.499	0.390	0.807	1.029

RP	PERCENT		INCIDENCE		DEV	D-FACT	EFF	LOSS COEFF		LOSS PARAM	
	SPAN	MEAN	SS	TOT				PROF	TOT	PROF	
1	5.00	14.1	7.4	11.6	0.422	0.	0.225	0.225	0.074	0.074	
2	10.00	8.0	1.4	10.3	0.351	0.	0.117	0.117	0.038	0.038	
3	20.00	5.5	-0.7	7.3	0.334	0.	0.085	0.085	0.026	0.026	
4	30.00	5.8	-0.0	7.4	0.337	0.	0.097	0.097	0.029	0.029	
5	38.00	6.9	1.5	8.9	0.356	0.	0.122	0.122	0.035	0.035	
6	46.00	5.4	0.3	6.2	0.388	0.	0.164	0.164	0.045	0.045	
7	50.00	4.0	-1.0	6.7	0.403	0.	0.199	0.199	0.053	0.053	
8	70.00	0.2	-4.0	8.6	0.437	0.	0.129	0.129	0.031	0.031	
9	80.00	0.7	-3.2	7.3	0.432	0.	0.082	0.082	0.018	0.018	
10	90.00	-0.9	-4.5	6.3	0.458	0.	-0.014	-0.014	-0.003	-0.003	
11	95.00	0.8	-2.6	8.8	0.557	0.	0.216	0.216	0.044	0.044	

TABLE IX. - Continued.

(s) Reading 950

RP	RADII		ABS BETAM		REL BETAM		TOTAL TEMP		TOTAL PRESS	
	IN	OUT	IN	OUT	IN	OUT	IN	RATIO	IN	RATIO
1	24.447	24.359	44.6	2.0	44.6	2.0	350.6	0.992	15.83	0.944
2	23.937	23.896	38.6	1.1	38.6	1.1	340.9	1.004	15.79	0.978
3	22.913	22.969	36.3	-1.3	36.3	-1.3	335.9	1.000	15.85	0.981
4	21.887	22.037	37.2	-0.9	37.2	-0.9	335.5	0.998	15.90	0.981
5	21.064	21.290	40.1	0.9	40.1	0.9	336.1	0.994	15.91	0.974
6	20.239	20.544	39.6	-2.6	39.6	-2.6	332.1	0.997	15.27	0.975
7	19.827	20.173	37.7	-2.2	37.7	-2.2	330.9	0.998	15.52	0.967
8	17.767	18.326	34.7	-1.5	34.7	-1.5	329.3	0.995	15.78	0.967
9	16.739	17.412	36.8	-1.6	36.8	-1.6	328.8	0.995	15.69	0.969
10	15.715	16.500	37.4	-4.0	37.4	-4.0	327.1	1.004	15.37	0.983
11	15.207	16.040	40.3	-2.0	40.3	-2.0	331.0	0.998	15.82	0.947

RP	ABS VEL		REL VEL		MERID VEL		TANG VEL		WHEEL SPEED	
	IN	OUT	IN	OUT	IN	OUT	IN	OUT	IN	OUT
1	207.0	165.9	207.0	165.9	147.5	165.8	145.3	5.9	0.	0.
2	205.0	181.3	205.0	181.3	160.1	181.3	128.0	3.4	0.	0.
3	208.6	188.6	208.6	188.6	168.0	188.5	123.6	-4.2	0.	0.
4	212.6	189.6	212.6	189.6	169.4	189.6	128.5	-3.0	0.	0.
5	211.2	183.1	211.2	183.1	161.7	183.1	135.9	2.9	0.	0.
6	203.5	174.2	203.5	174.2	156.9	174.0	129.7	-8.0	0.	0.
7	210.0	175.1	210.0	175.1	166.1	175.0	128.5	-6.7	0.	0.
8	236.8	184.5	236.8	184.5	194.8	184.5	134.7	-4.7	0.	0.
9	237.7	181.2	237.7	181.2	190.3	181.1	142.6	-5.0	0.	0.
10	236.2	177.7	238.2	177.7	189.1	177.3	144.8	-12.5	0.	0.
11	252.7	173.4	252.7	173.4	192.8	173.3	163.4	-6.1	0.	0.

RP	ABS MACH NO		REL MACH NO		MERID MACH NO		MERID PEAK SS	
	IN	OUT	IN	OUT	IN	OUT	VEL R	MACH NO
1	0.569	0.453	0.569	0.453	0.406	0.452	1.124	1.014
2	0.572	0.501	0.572	0.501	0.446	0.501	1.132	0.901
3	0.587	0.527	0.587	0.527	0.473	0.527	1.122	0.874
4	0.600	0.531	0.600	0.531	0.478	0.531	1.119	0.902
5	0.595	0.513	0.595	0.513	0.455	0.513	1.132	0.942
6	0.575	0.489	0.575	0.489	0.444	0.488	1.109	0.889
7	0.596	0.492	0.596	0.492	0.471	0.492	1.054	0.877
8	0.680	0.522	0.680	0.522	0.560	0.522	0.947	0.875
9	0.684	0.513	0.684	0.513	0.547	0.512	0.952	0.899
10	0.687	0.501	0.687	0.501	0.546	0.500	0.937	0.877
11	0.729	0.487	0.729	0.487	0.556	0.487	0.899	0.985

RP	PERCENT		INCIDENCE		DEV	D-FACT	EFF	LOSS COEFF		LOSS PARAM	
	SPAN		MEAN	SS				TOT	PROF	TOT	PROF
1	5.00		9.3	2.5	10.5	0.420	0.	0.284	0.284	0.093	0.093
2	10.00		3.7	-2.8	9.4	0.311	0.	0.110	0.110	0.035	0.035
3	20.00		2.2	-4.0	6.6	0.285	0.	0.093	0.093	0.029	0.029
4	30.00		3.1	-2.7	6.8	0.290	0.	0.088	0.088	0.026	0.026
5	38.00		5.5	0.0	8.5	0.311	0.	0.124	0.124	0.035	0.035
6	46.00		4.3	-0.9	5.0	0.328	0.	0.125	0.125	0.034	0.034
7	50.00		2.0	-3.0	5.5	0.337	0.	0.156	0.156	0.042	0.042
8	70.00		-3.8	-8.0	6.3	0.360	0.	0.123	0.123	0.030	0.030
9	80.00		-3.4	-7.3	6.3	0.376	0.	0.117	0.117	0.026	0.026
10	90.00		-4.9	-8.5	4.1	0.391	0.	0.063	0.063	0.013	0.013
11	95.00		-3.0	-6.4	6.1	0.448	0.	0.177	0.177	0.036	0.036

TABLE IX. - Concluded.

(t) Reading 963

RP	RADII		ABS BETAM		REL BETAM		TOTAL TEMP		TOTAL PRESS	
	IN	OUT	IN	OUT	IN	OUT	IN	RATIO	IN	RATIO
1	24.447	24.359	35.4	0.4	35.4	0.4	339.0	0.999	14.64	0.941
2	23.937	23.896	31.1	-1.5	31.1	-1.5	331.7	1.005	14.66	0.977
3	22.913	22.969	30.5	-3.1	30.5	-3.1	329.2	1.000	14.93	0.966
4	21.887	22.037	31.5	-2.0	31.5	-2.0	329.3	1.000	14.97	0.973
5	21.064	21.290	35.4	-0.4	35.4	-0.4	330.7	0.994	15.00	0.963
6	20.239	20.544	35.9	-3.9	35.9	-3.9	326.7	0.996	14.03	0.980
7	19.827	20.173	34.6	-3.6	34.6	-3.6	326.4	0.995	14.38	0.959
8	17.767	18.326	31.1	-2.9	31.1	-2.9	326.8	0.992	15.05	0.972
9	16.739	17.412	32.0	-3.1	32.0	-3.1	325.9	0.994	15.20	0.966
10	15.715	16.500	33.7	-3.4	33.7	-3.4	326.6	0.992	15.30	0.960
11	15.207	16.040	36.2	-1.5	36.2	-1.5	329.9	0.992	15.58	0.952

RP	ABS VEL		REL VEL		MERID VEL		TANG VEL		WHEEL SPEED	
	IN	OUT	IN	OUT	IN	OUT	IN	OUT	IN	OUT
1	200.1	181.3	200.1	181.3	163.0	181.3	116.1	1.2	0.	0.
2	200.0	197.0	200.0	197.0	171.2	197.0	103.4	-5.3	0.	0.
3	206.7	204.8	206.7	204.8	178.1	204.5	105.0	-11.2	0.	0.
4	212.1	206.7	212.1	206.7	180.8	206.5	111.0	-7.3	0.	0.
5	206.8	200.8	206.8	200.8	168.7	200.8	119.7	-1.3	0.	0.
6	192.3	189.6	192.3	189.6	155.7	189.2	112.9	-13.1	0.	0.
7	201.9	189.3	201.9	189.3	166.1	188.9	114.7	-12.0	0.	0.
8	244.4	203.0	244.4	203.0	209.4	202.7	126.1	-10.1	0.	0.
9	250.6	202.9	250.6	202.9	212.6	202.6	132.6	-11.1	0.	0.
10	259.5	203.6	259.5	203.6	215.9	203.3	144.0	-12.1	0.	0.
11	269.5	206.8	269.5	206.8	217.5	206.7	159.1	-5.3	0.	0.

RP	ABS MACH NO		REL MACH NO		MERID MACH NO		MERID PEAK SS	
	IN	OUT	IN	OUT	IN	OUT	VEL R	MACH NO
1	0.559	0.504	0.559	0.504	0.455	0.504	1.112	0.822
2	0.565	0.555	0.565	0.555	0.484	0.554	1.150	0.744
3	0.588	0.582	0.588	0.582	0.506	0.581	1.149	0.755
4	0.604	0.587	0.604	0.587	0.515	0.587	1.143	0.790
5	0.587	0.570	0.587	0.570	0.478	0.570	1.190	0.835
6	0.546	0.539	0.546	0.539	0.442	0.538	1.215	0.777
7	0.576	0.539	0.576	0.539	0.474	0.538	1.137	0.785
8	0.707	0.581	0.707	0.581	0.606	0.580	0.968	0.807
9	0.728	0.581	0.728	0.581	0.618	0.580	0.953	0.813
10	0.756	0.583	0.756	0.583	0.629	0.582	0.941	0.849
11	0.785	0.590	0.785	0.590	0.633	0.589	0.950	0.939

RP	PERCENT	INCIDENCE		DEV	D-FACT	EFF	LOSS COEFF		LOSS PARAM	
	SPAN	MEAN	SS				TOT	PROF	TOT	PROF
1	5.00	0.2	-6.6	8.9	0.283	0.	0.306	0.306	0.101	0.101
2	10.00	-3.8	-10.3	6.8	0.190	0.	0.120	0.120	0.039	0.039
3	20.00	-3.7	-9.9	4.8	0.182	0.	0.161	0.161	0.050	0.050
4	30.00	-2.5	-8.3	5.6	0.190	0.	0.124	0.124	0.037	0.037
5	38.00	0.8	-4.7	7.2	0.195	0.	0.180	0.180	0.051	0.051
6	46.00	0.6	-4.5	3.7	0.192	0.	0.111	0.111	0.030	0.030
7	50.00	-1.1	-6.1	4.0	0.229	0.	0.202	0.202	0.054	0.054
8	70.00	-7.4	-11.6	4.9	0.302	0.	0.099	0.099	0.024	0.024
9	80.00	-8.3	-12.2	4.8	0.318	0.	0.115	0.115	0.026	0.026
10	90.00	-8.6	-12.2	4.7	0.340	0.	0.126	0.126	0.027	0.027
11	95.00	-7.1	-10.5	6.7	0.355	0.	0.143	0.143	0.029	0.029

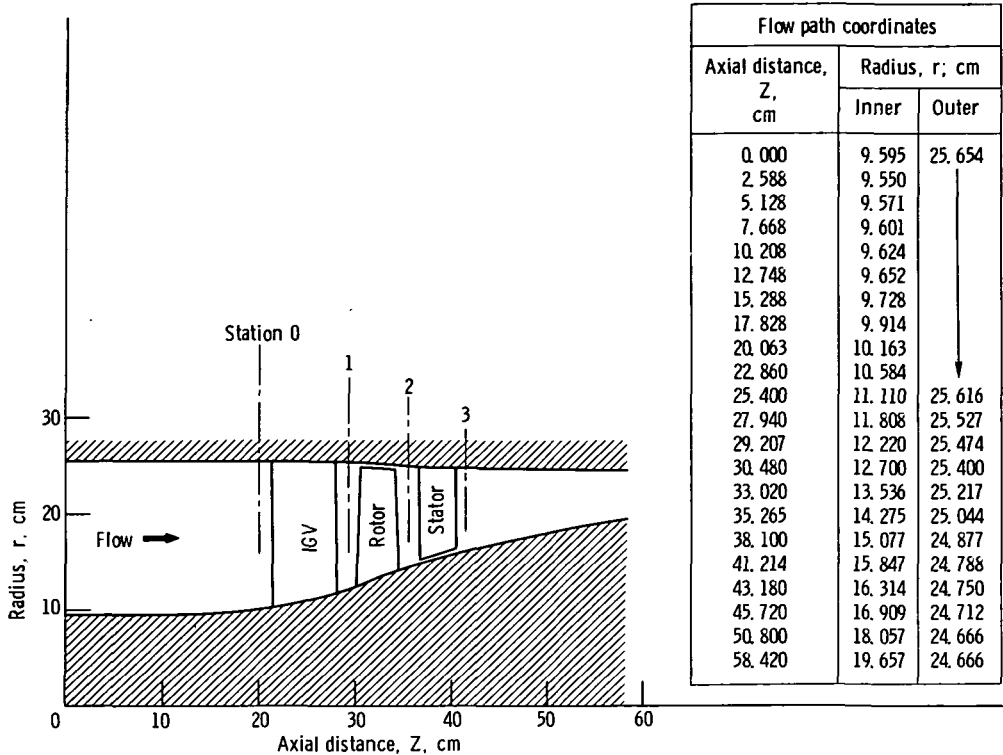

Figure 1 - Flow path for IGV and stage showing axial location of instrumentation.

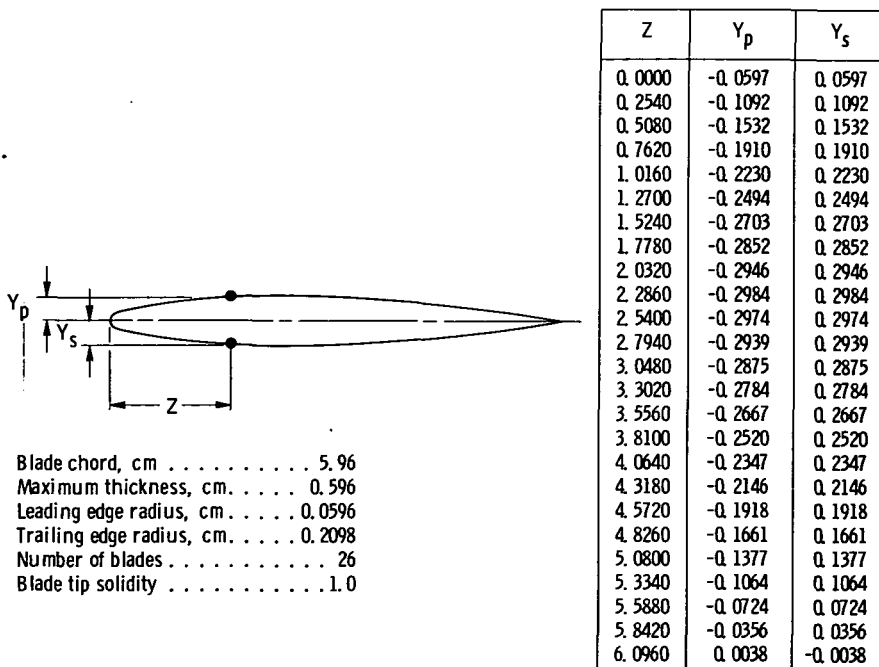
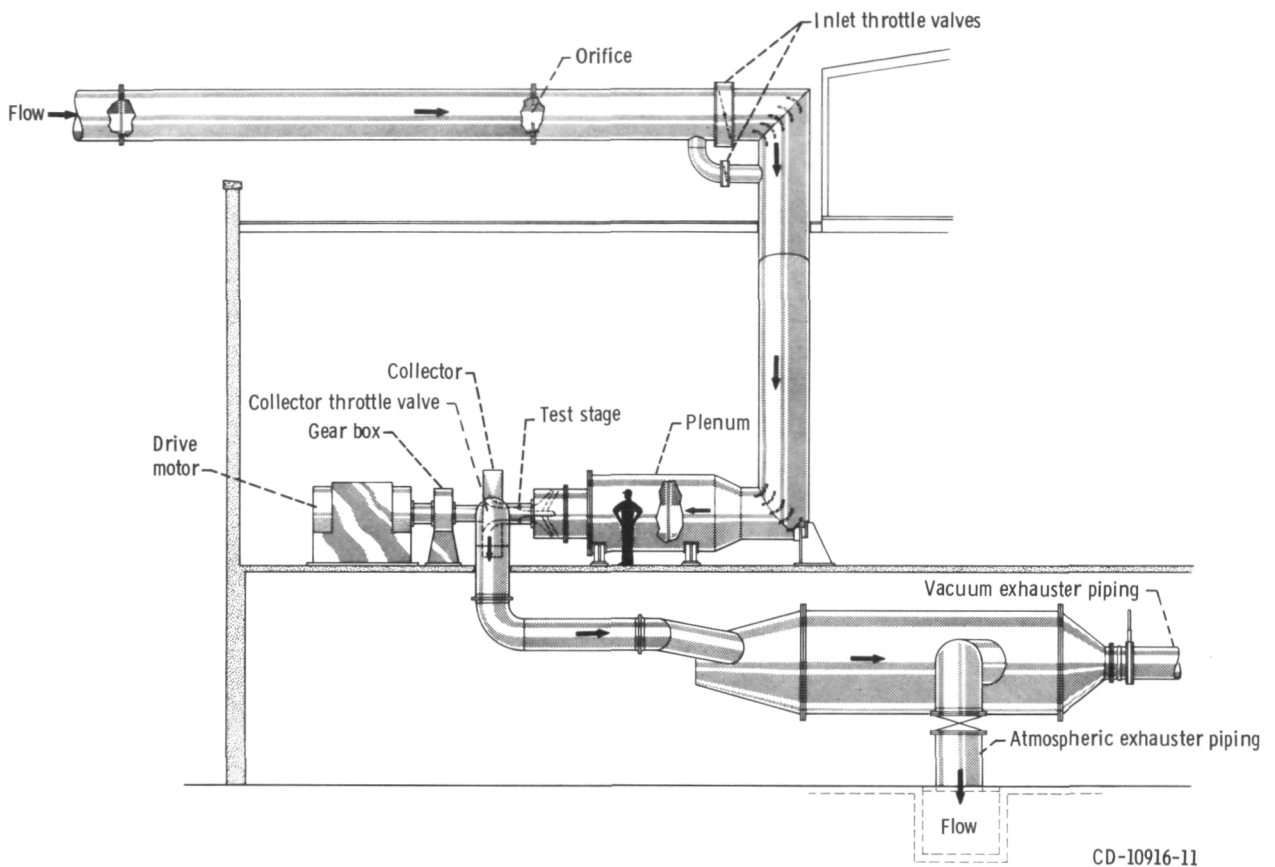
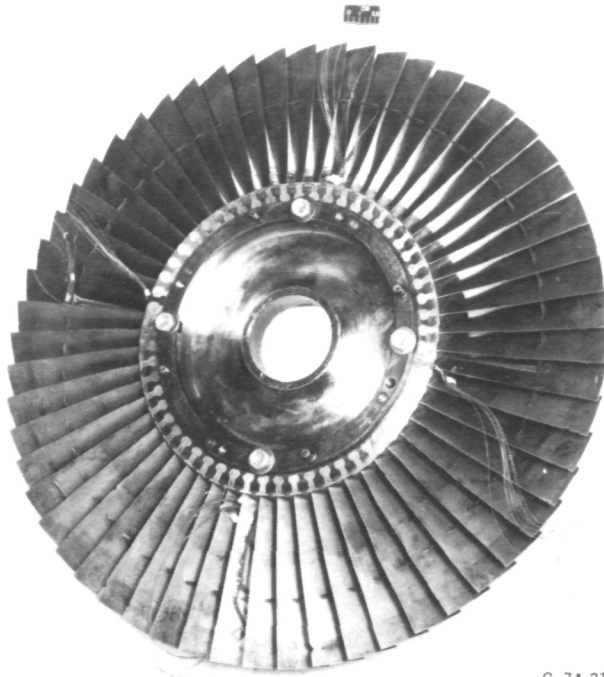

Figure 2 - Inlet guide vane.



CD-10916-11

Figure 3. - Compressor test facility.



C-74-3199

(a) Rotor.

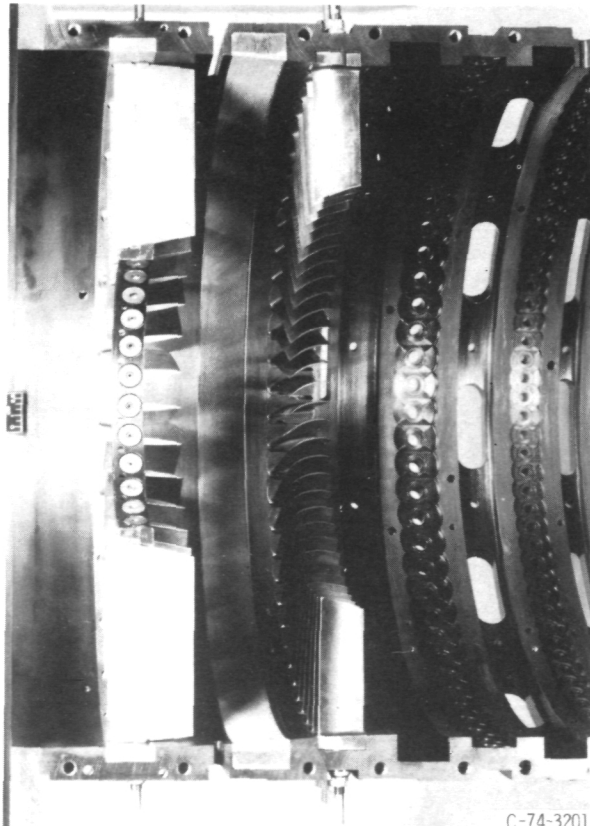

C-74-3201

(b) Compressor casing with IGV's and stators installed.

Figure 4. - Test hardware.

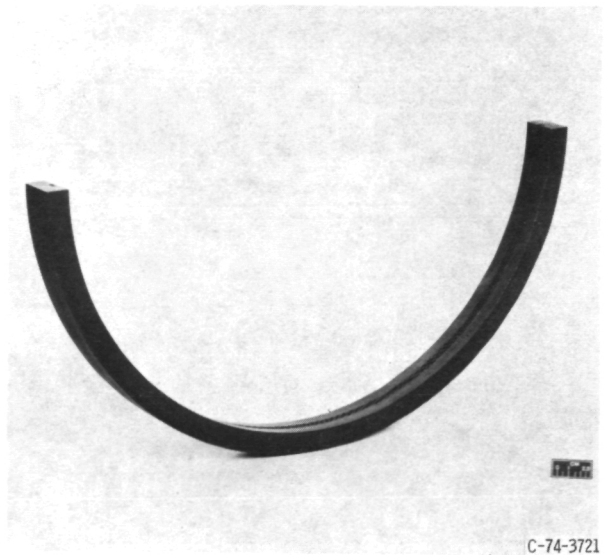
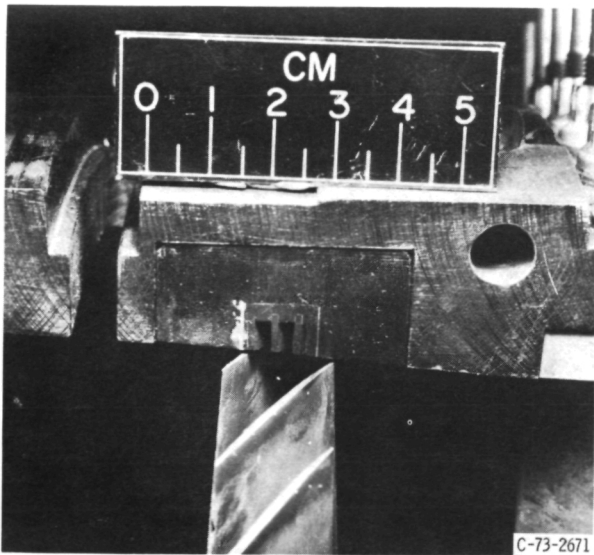
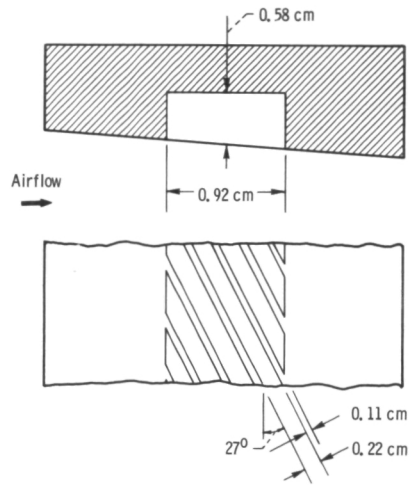

Figure 5. - Blade angle slots.

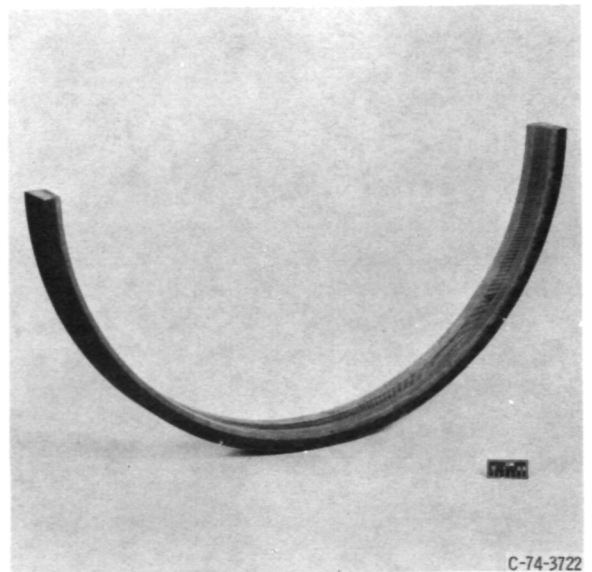
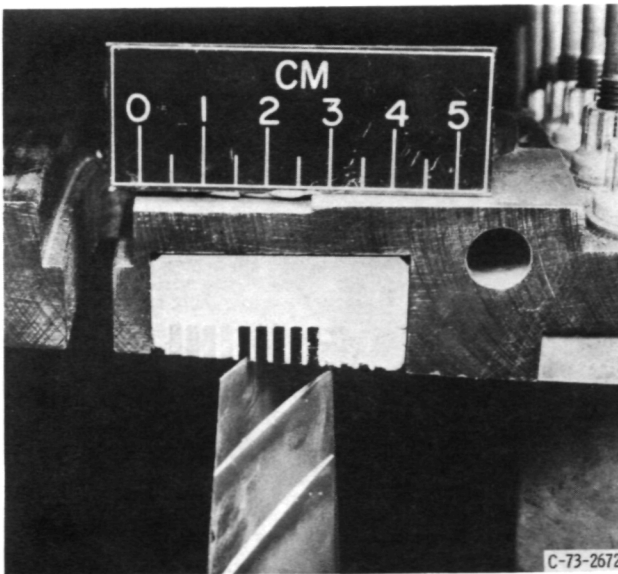
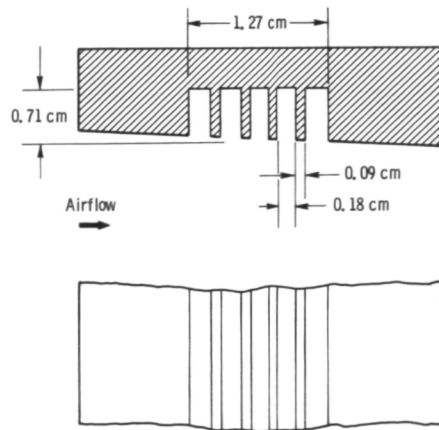

Figure 6. - Circumferential grooves.

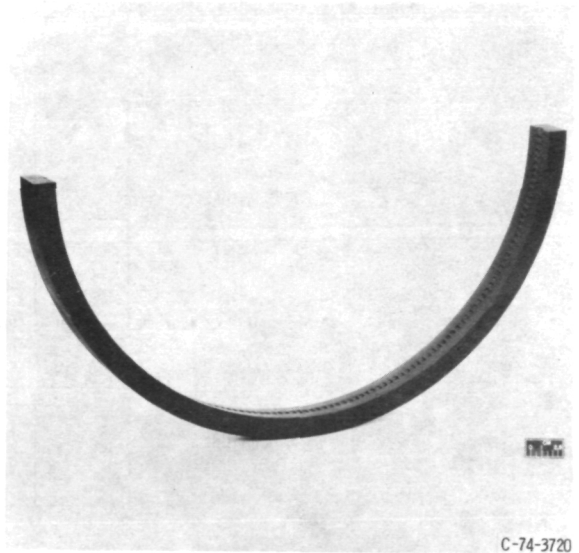
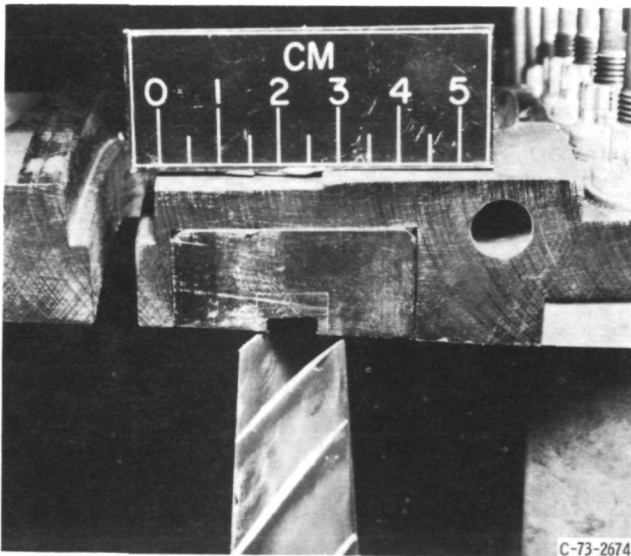
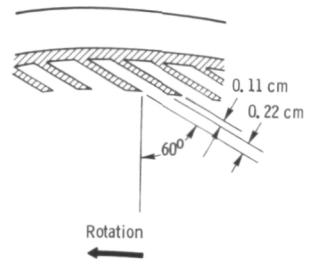
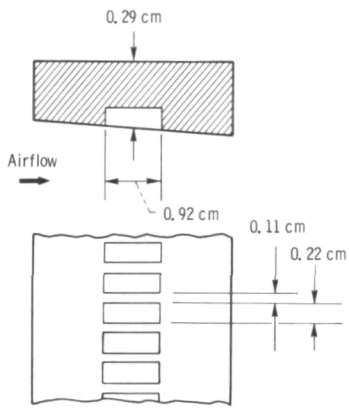

Figure 7. - Axial skewed slots.

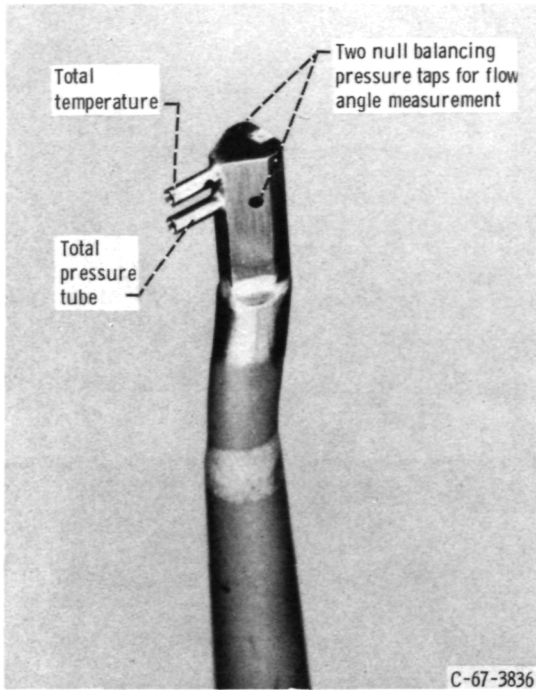

Figure 8. - Combination sensing probe.

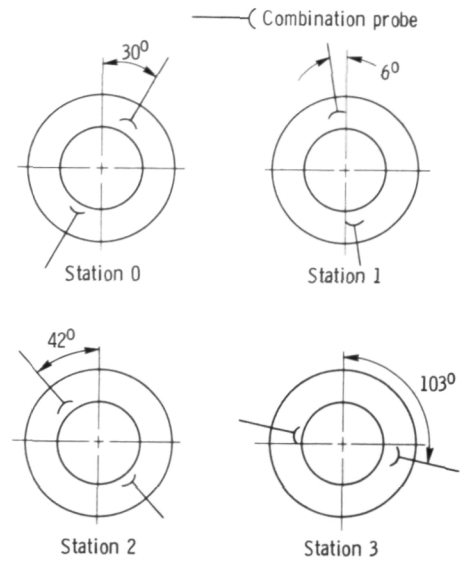

Figure 9. - Circumferential locations of measurements (looking downstream; clockwise rotation).

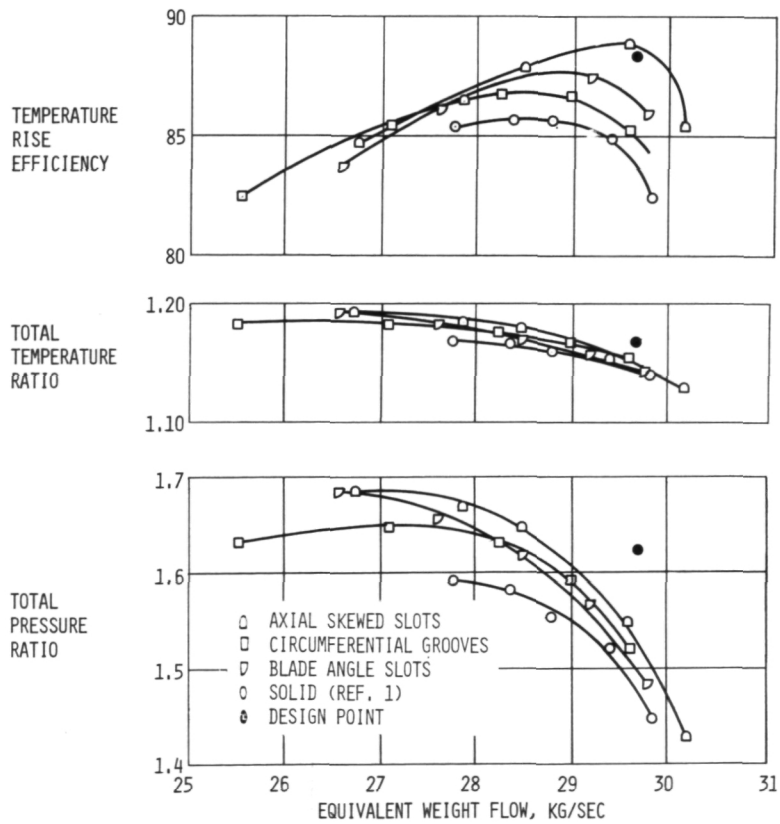

FIGURE 10. - ROTOR OVERALL PERFORMANCE.

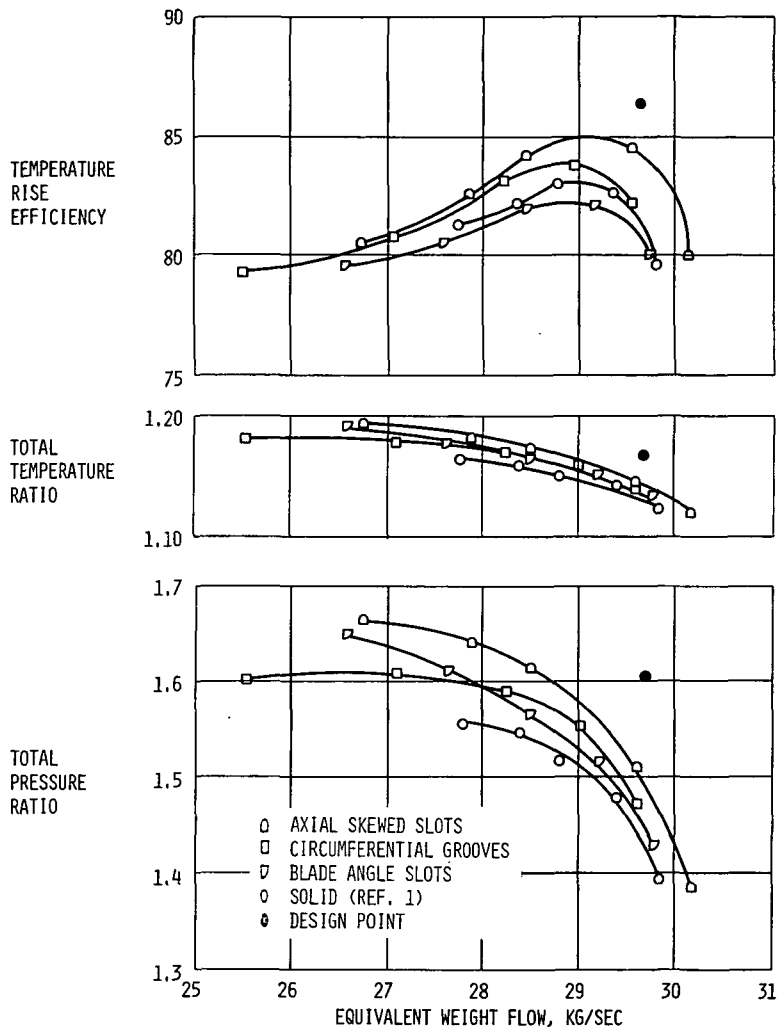

FIGURE 11. - STAGE OVERALL PERFORMANCE.

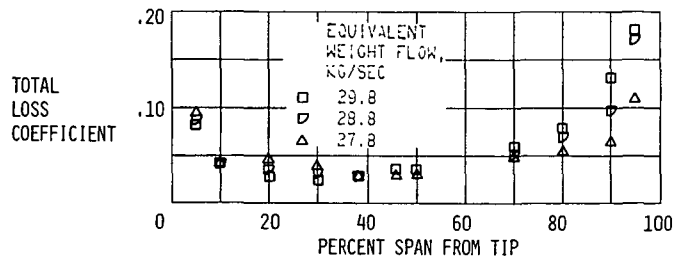
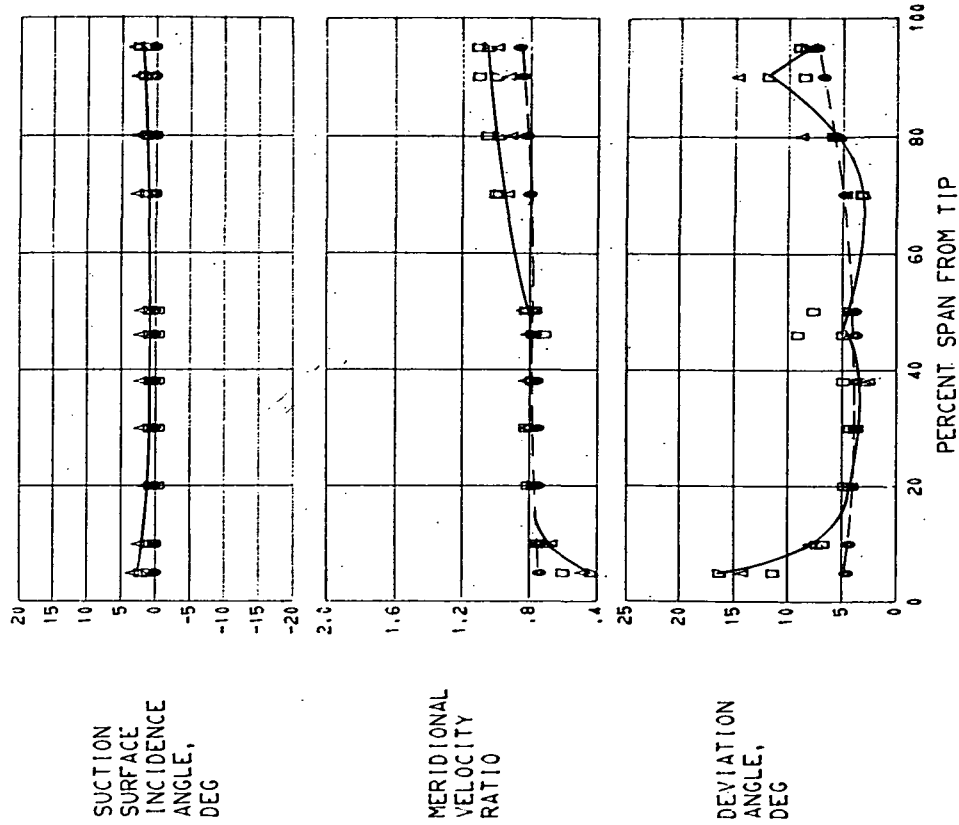
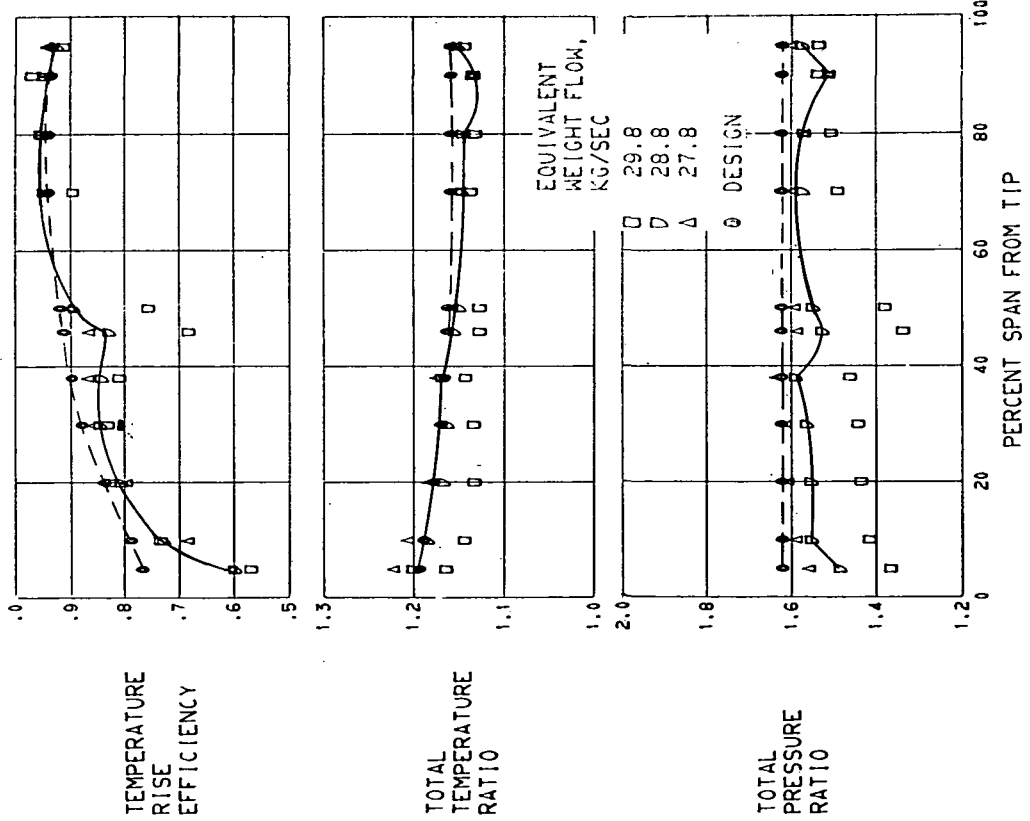

FIGURE 12. - RADIAL DISTRIBUTION OF INLET GUIDE VANE TOTAL LOSS COEFFICIENT.



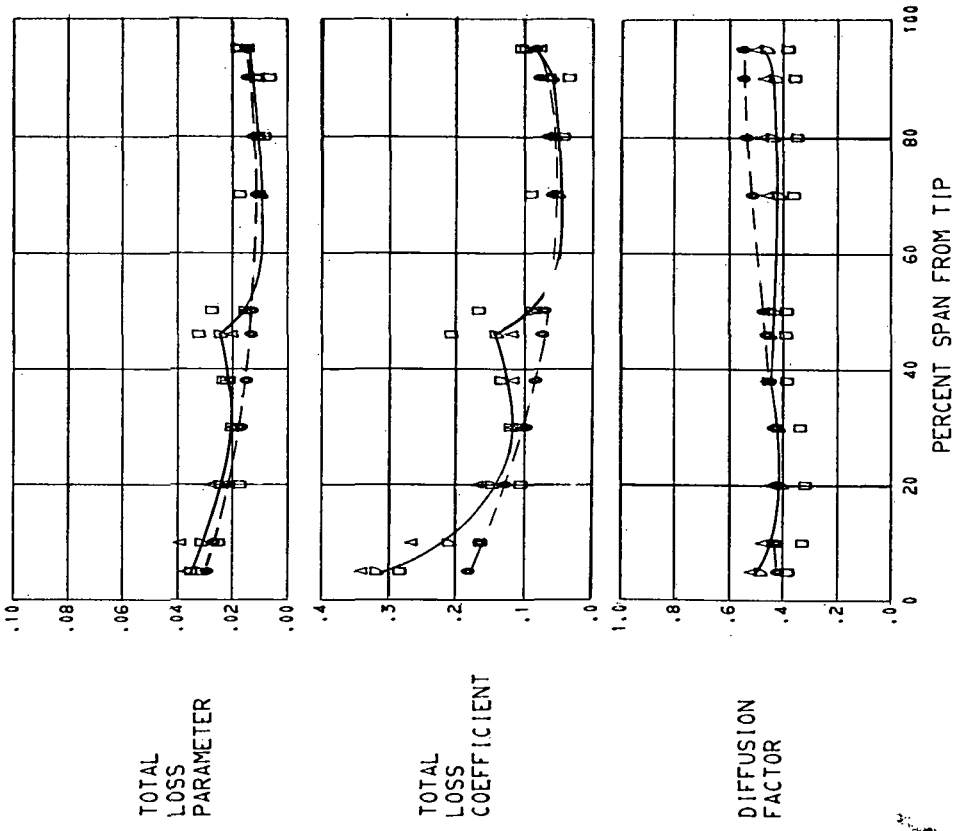

FIGURE 13. - RADIAL DISTRIBUTION OF PERFORMANCE FOR ROTOR WITH SOLID CASING (REF. 1), 100 PERCENT DESIGN SPEED.

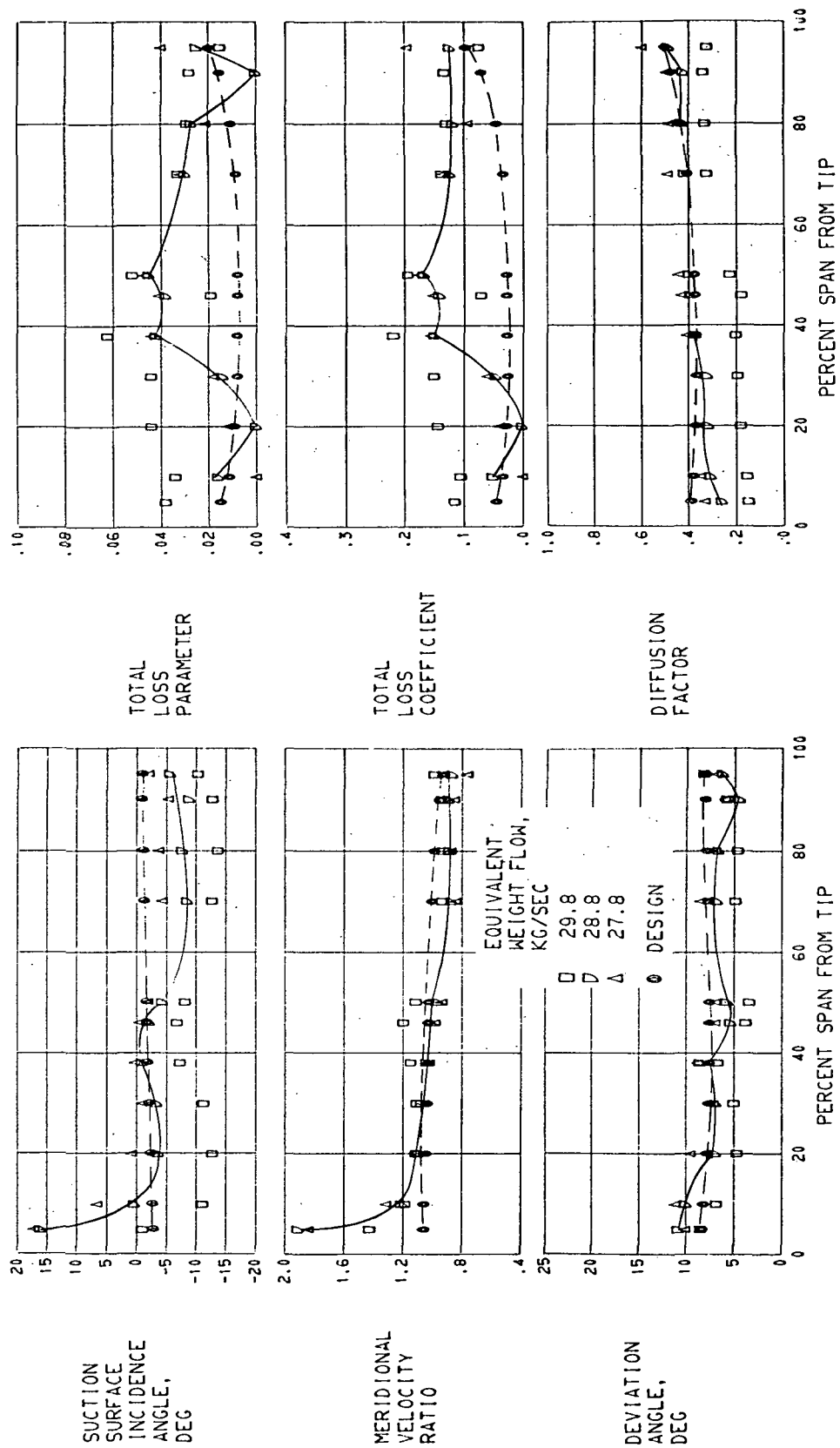
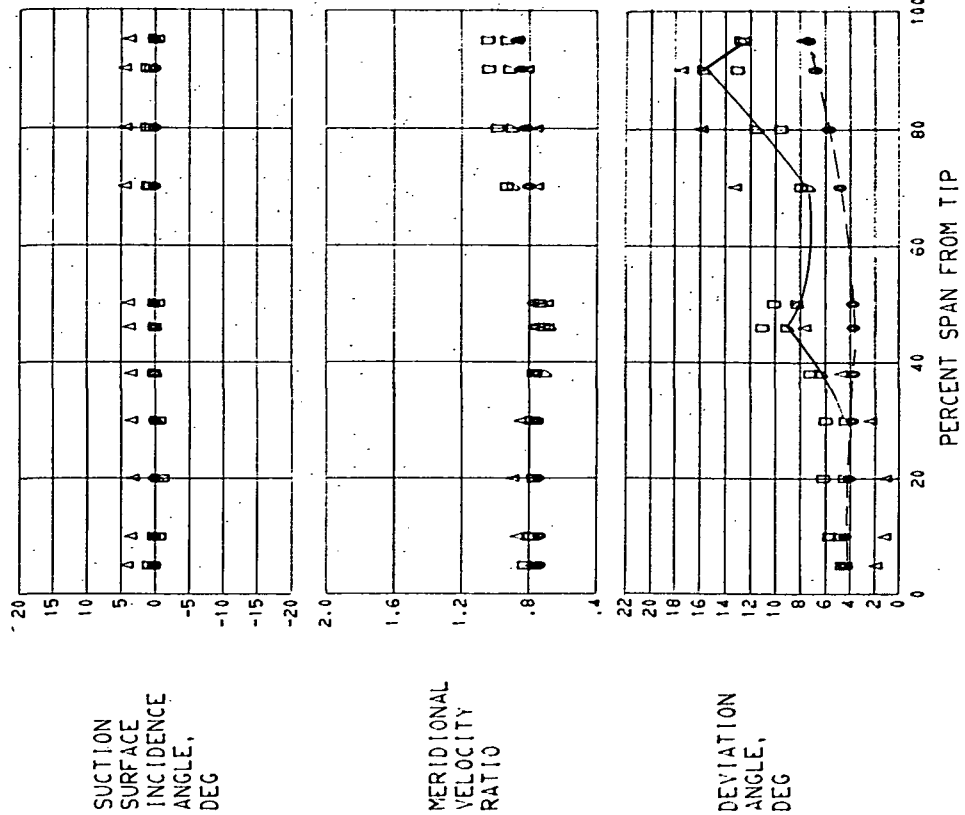
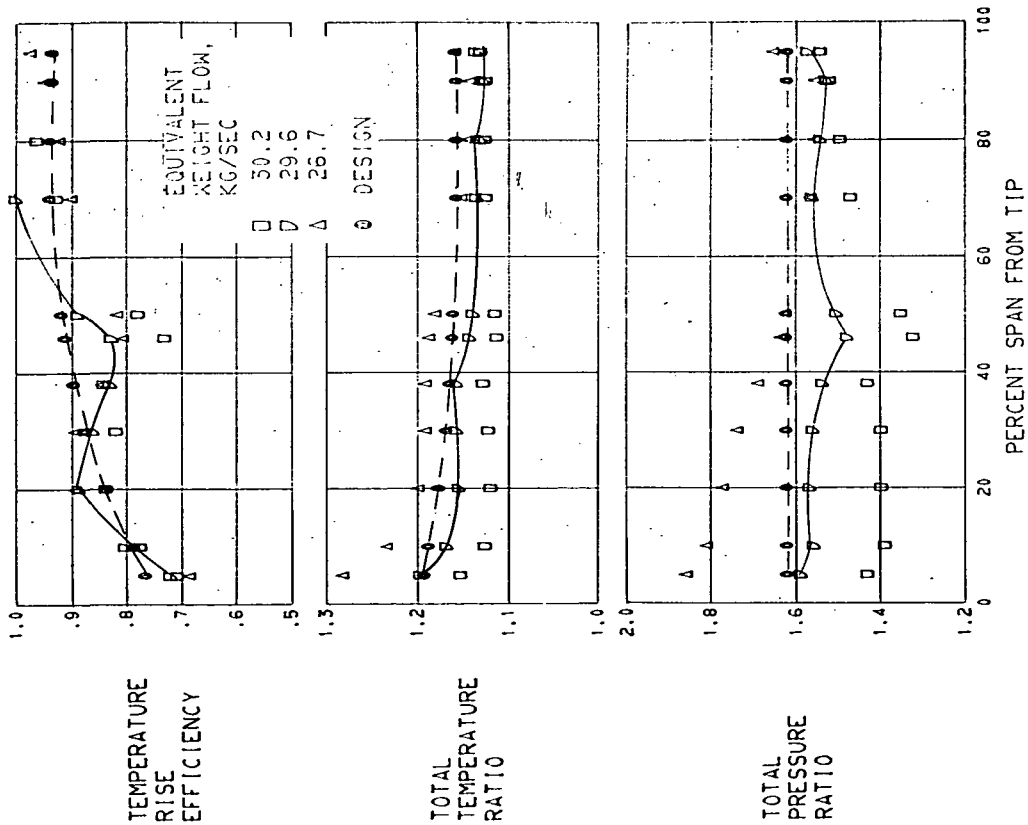

FIGURE 14. - RADIAL DISTRIBUTION OF PERFORMANCE FOR STATOR WITH SOLID CASING (REF. 1). 100 PERCENT DESIGN SPEED.



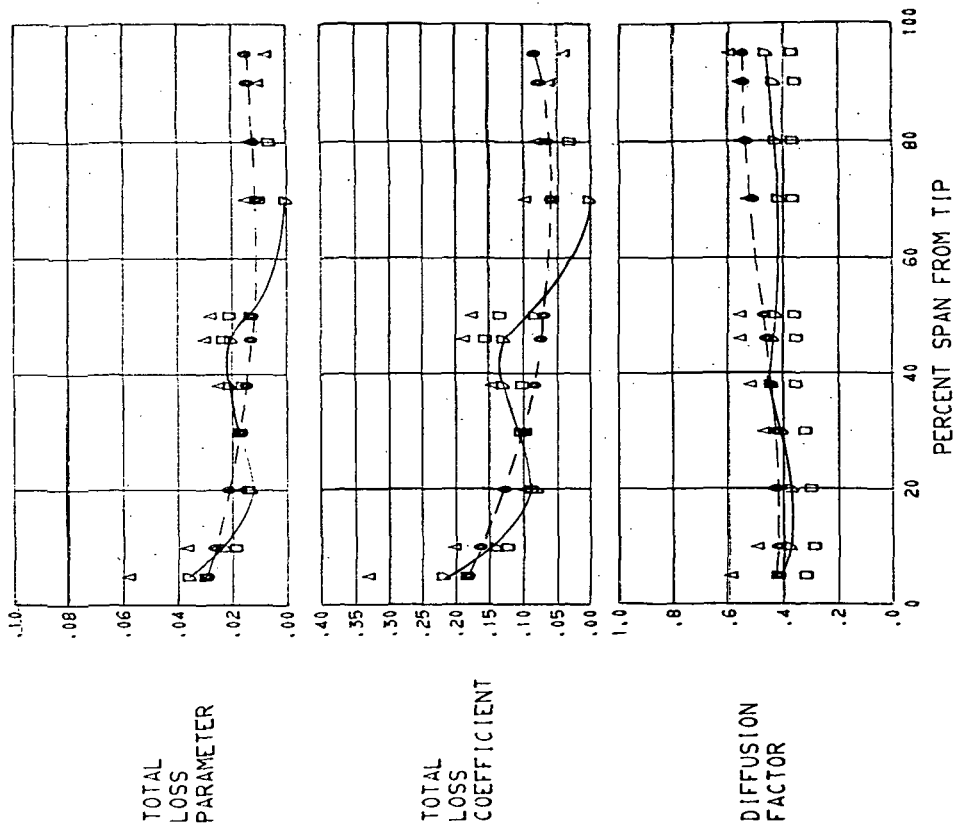

FIGURE 15. - RADIAL DISTRIBUTION OF PERFORMANCE FOR ROTOR WITH AXIAL SKEWED SLOTS CASING TREATMENT. 100 PERCENT DESIGN SPEED.

Page Intentionally Left Blank

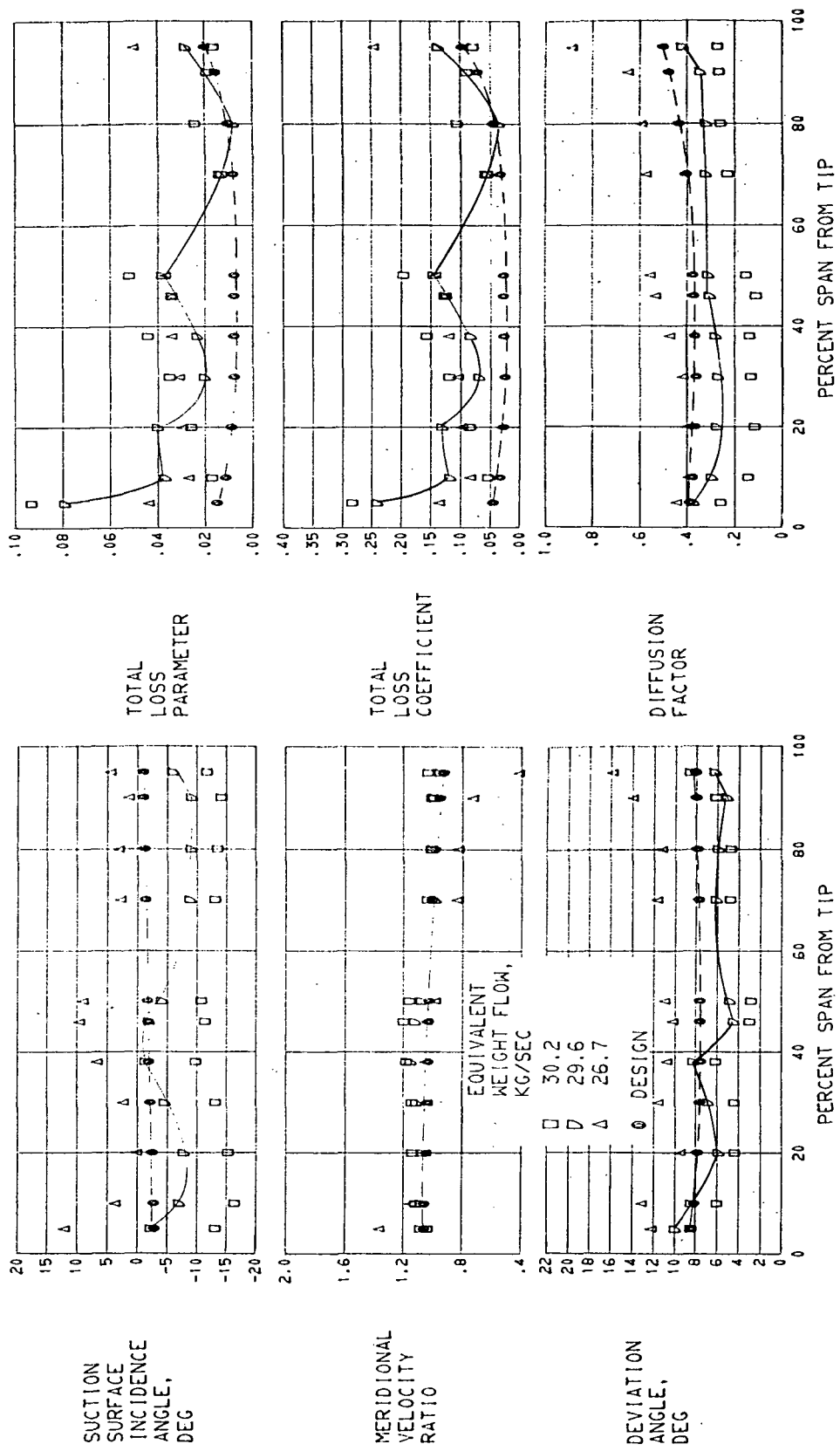
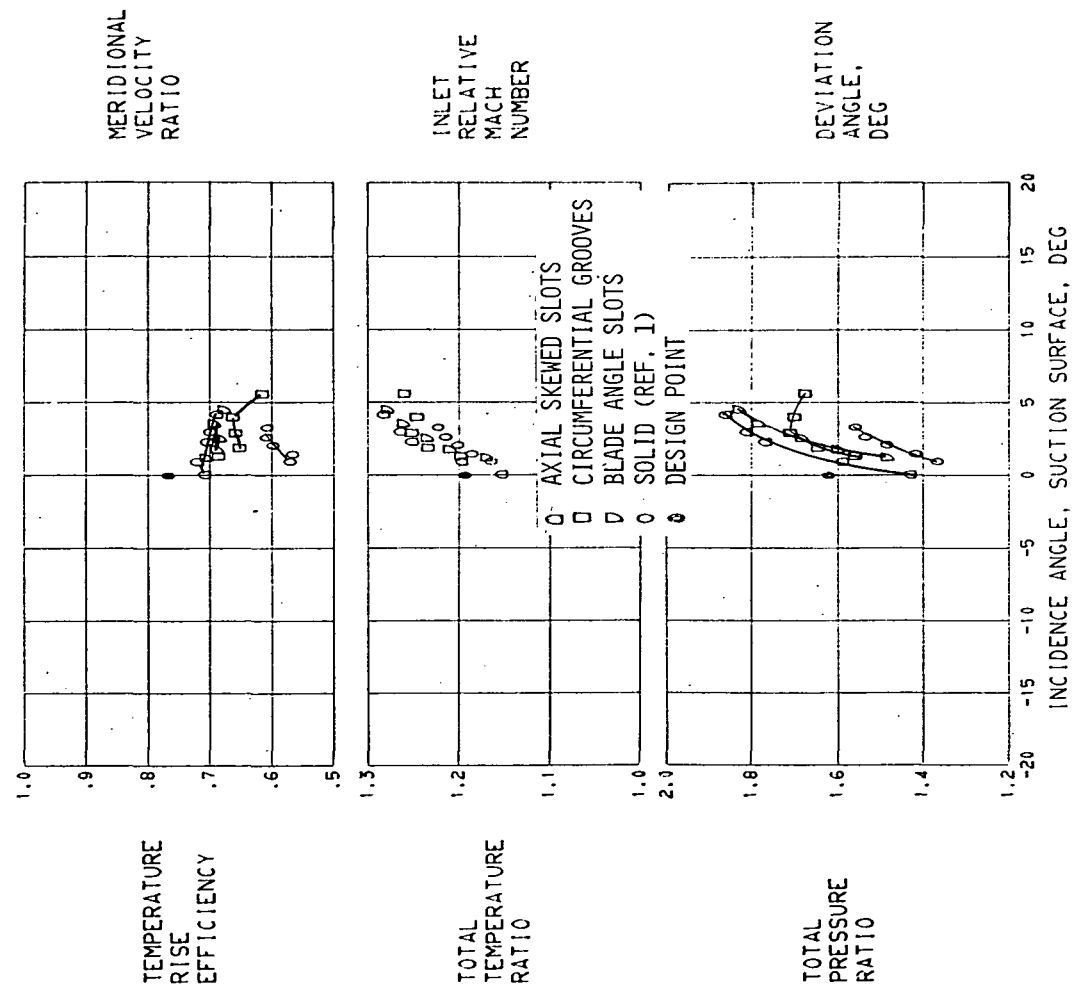
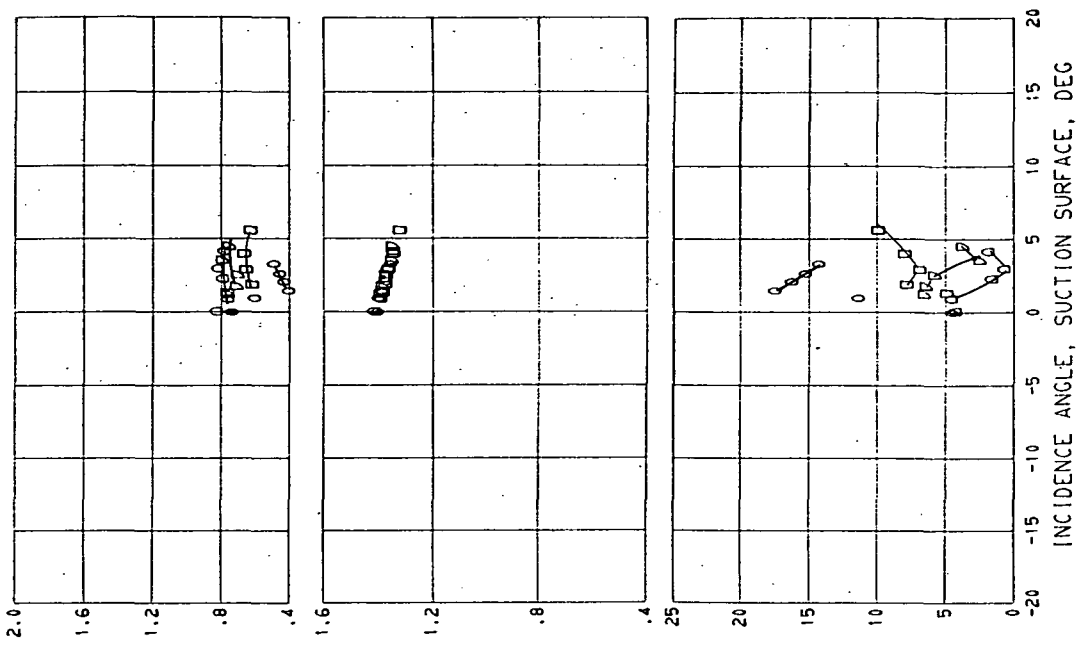
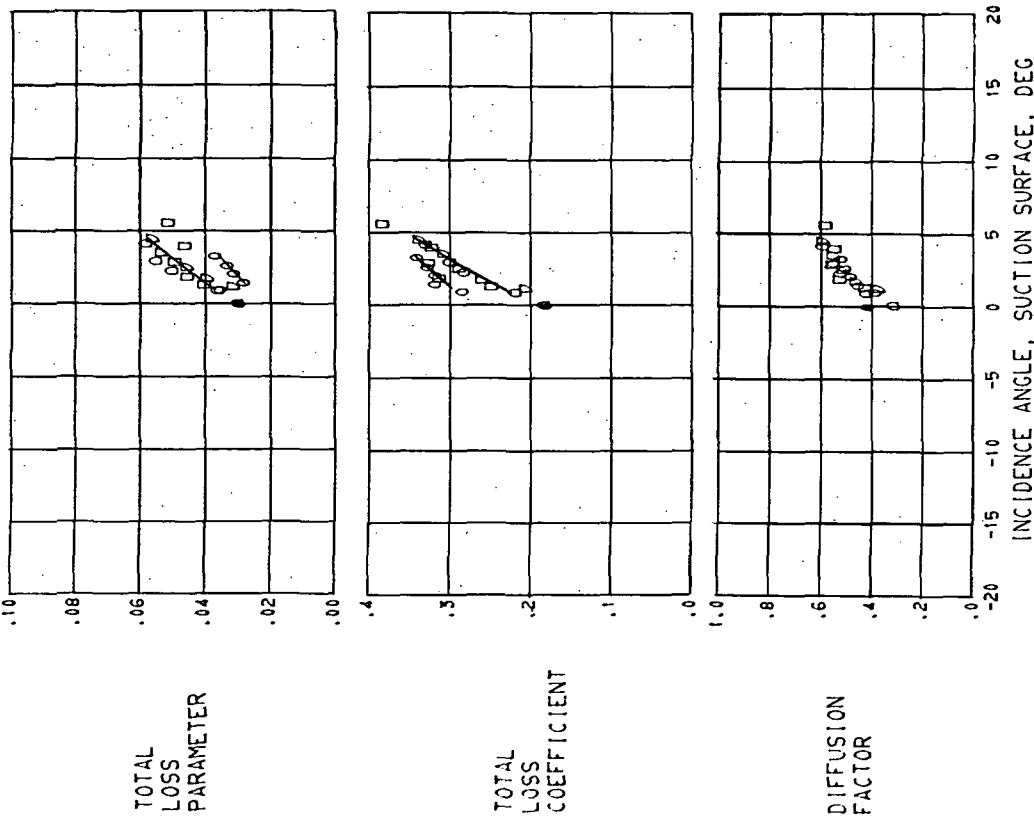

FIGURE 16. - RADIAL DISTRIBUTION OF PERFORMANCE FOR STATOR WITH AXIAL SKEWED SLOTS CASING TREATMENT, 100 PERCENT DESIGN SPEED.





(A) 5.0 PERCENT SPAN.

FIGURE 17. - BLADE-ELEMENT PERFORMANCE FOR ROTOR.

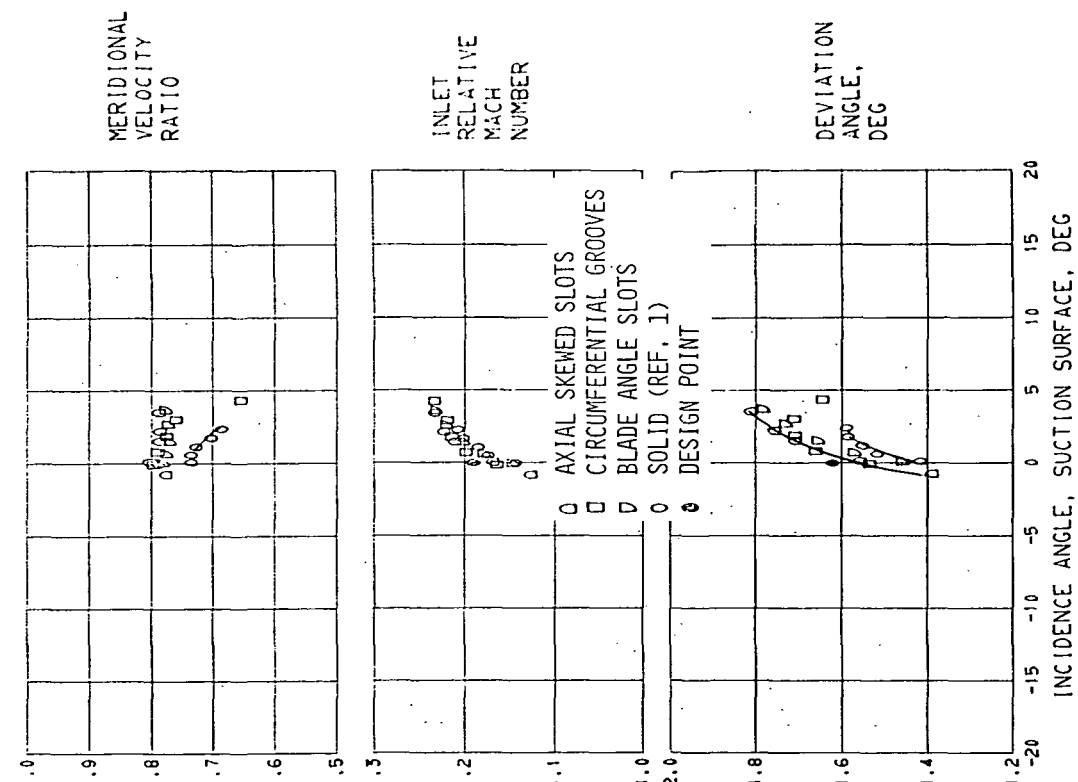
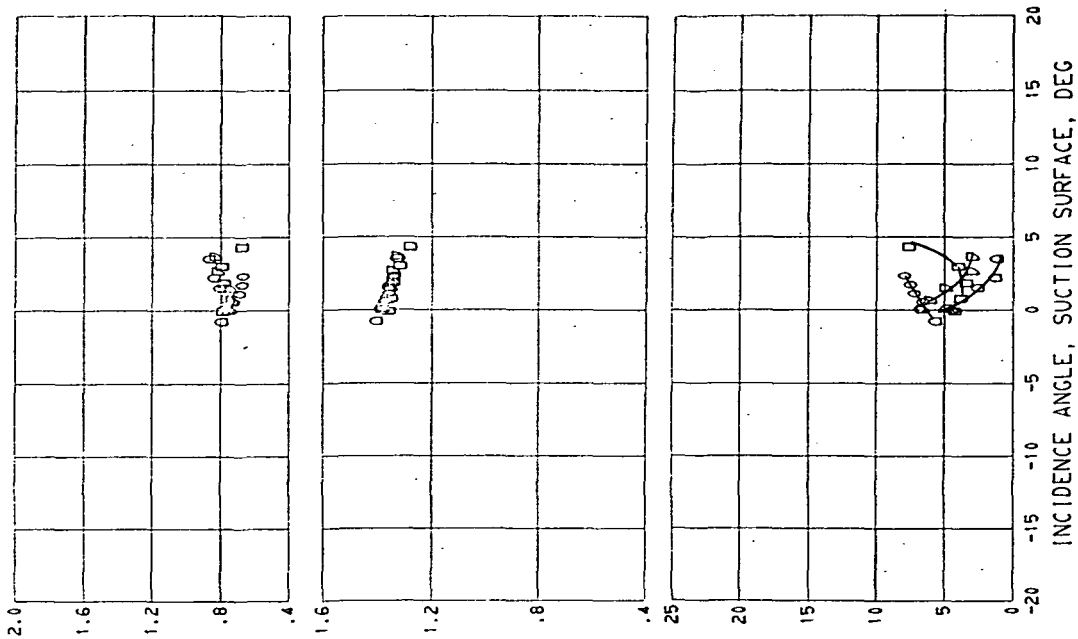

TEMPERATURE RISE EFFICIENCY

TOTAL TEMPERATURE RATIO

TOTAL PRESSURE RATIO

MERIDIONAL VELOCITY RATIO

INLET RELATIVE MACH NUMBER

DEVIATION ANGLE, DEG

- AXIAL SKEWED SLOTS
- CIRCUMFERENTIAL GROOVES
- △ BLADE ANGLE SLOTS
- ◇ SOLID (REF. 1)
- DESIGN POINT

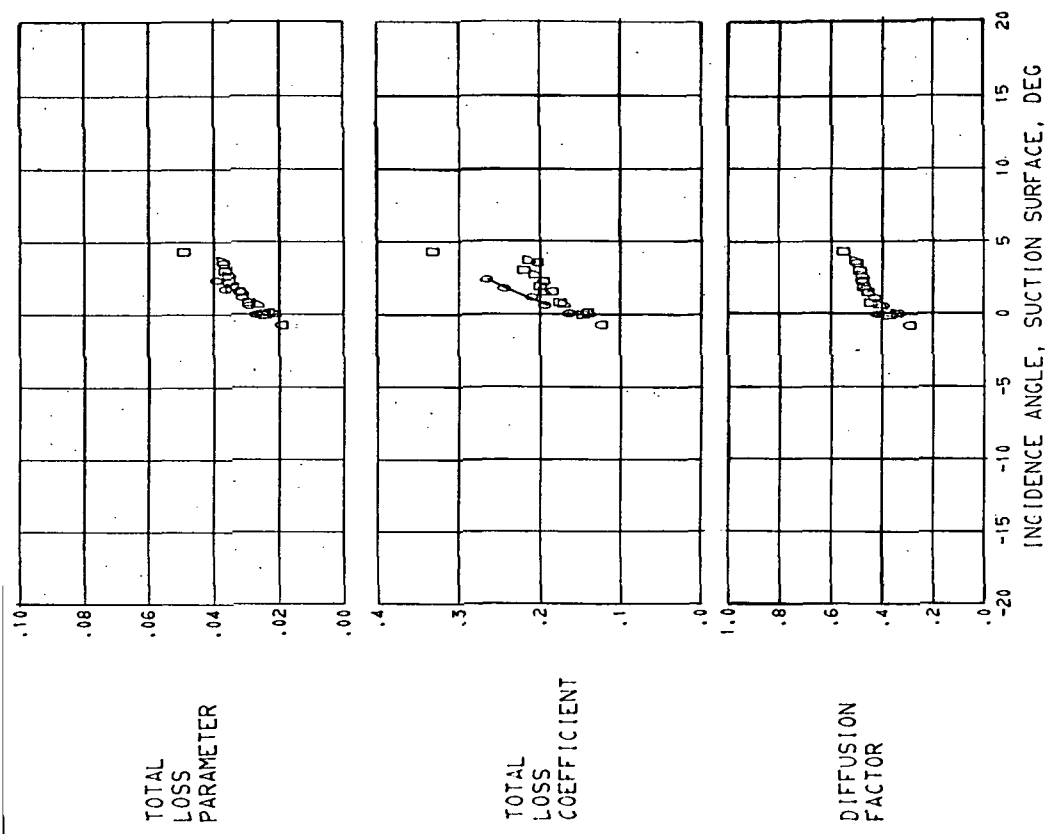

(B) 10.0 PERCENT SPAN.

FIGURE 17. - CONTINUED, BLADE-ELEMENT PERFORMANCE FOR ROTOR.

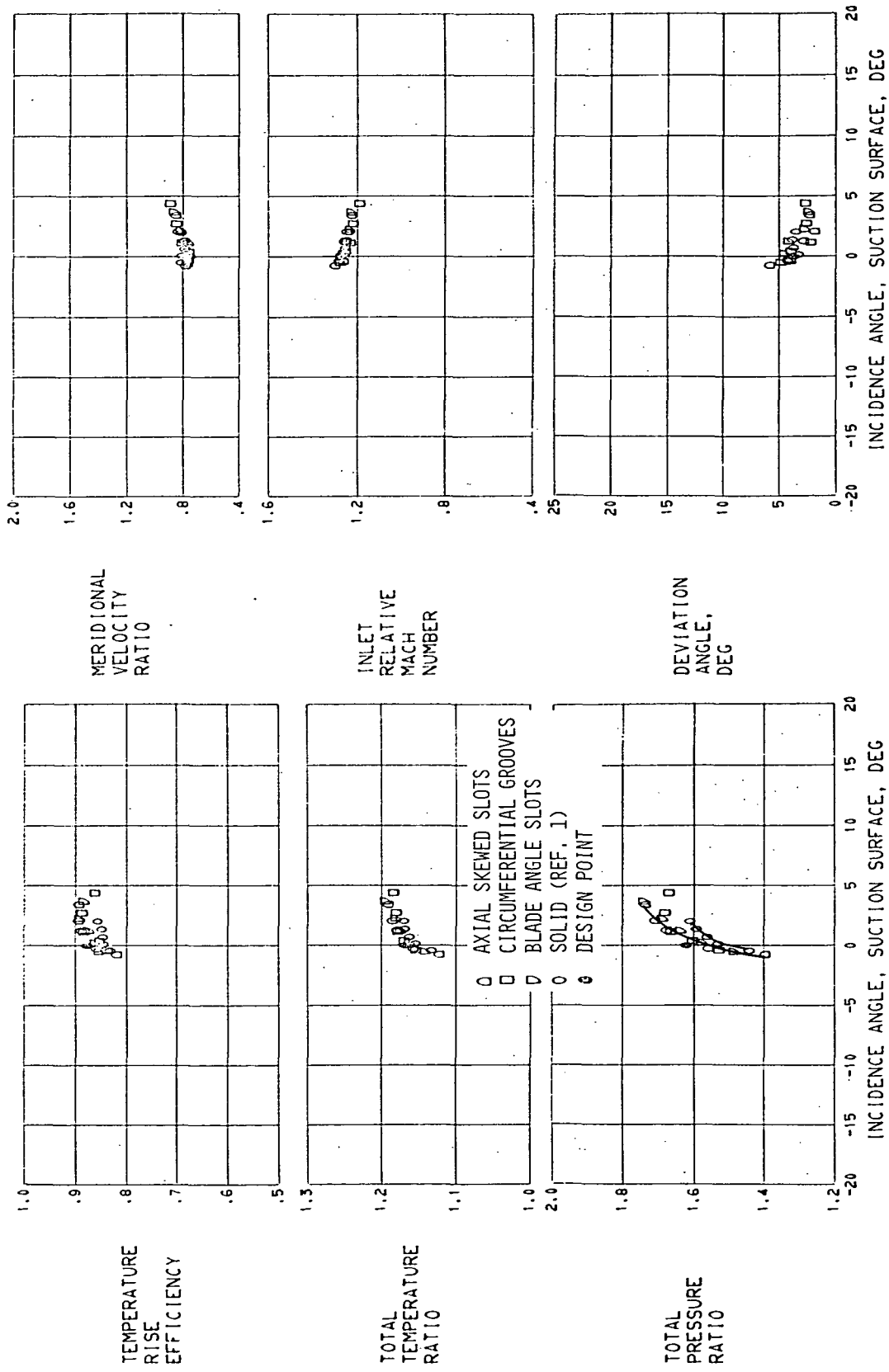

TOTAL
LOSS
PARAMETER

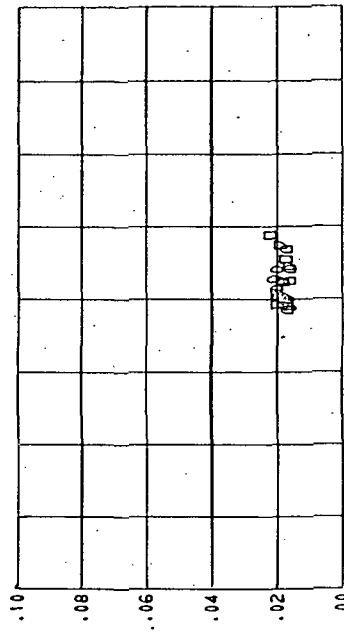

TOTAL
LOSS
COEFFICIENT

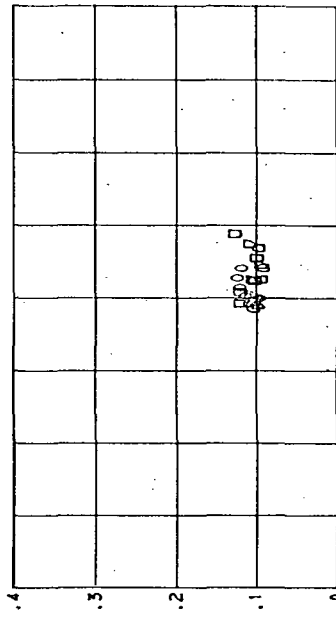

DIFFUSION
FACTOR

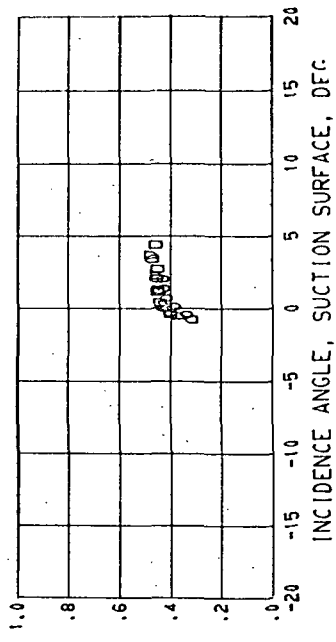

(C) 30.0 PERCENT SPAN.

FIGURE 17. - CONTINUED. BLADE-ELEMENT PERFORMANCE FOR ROTOR.

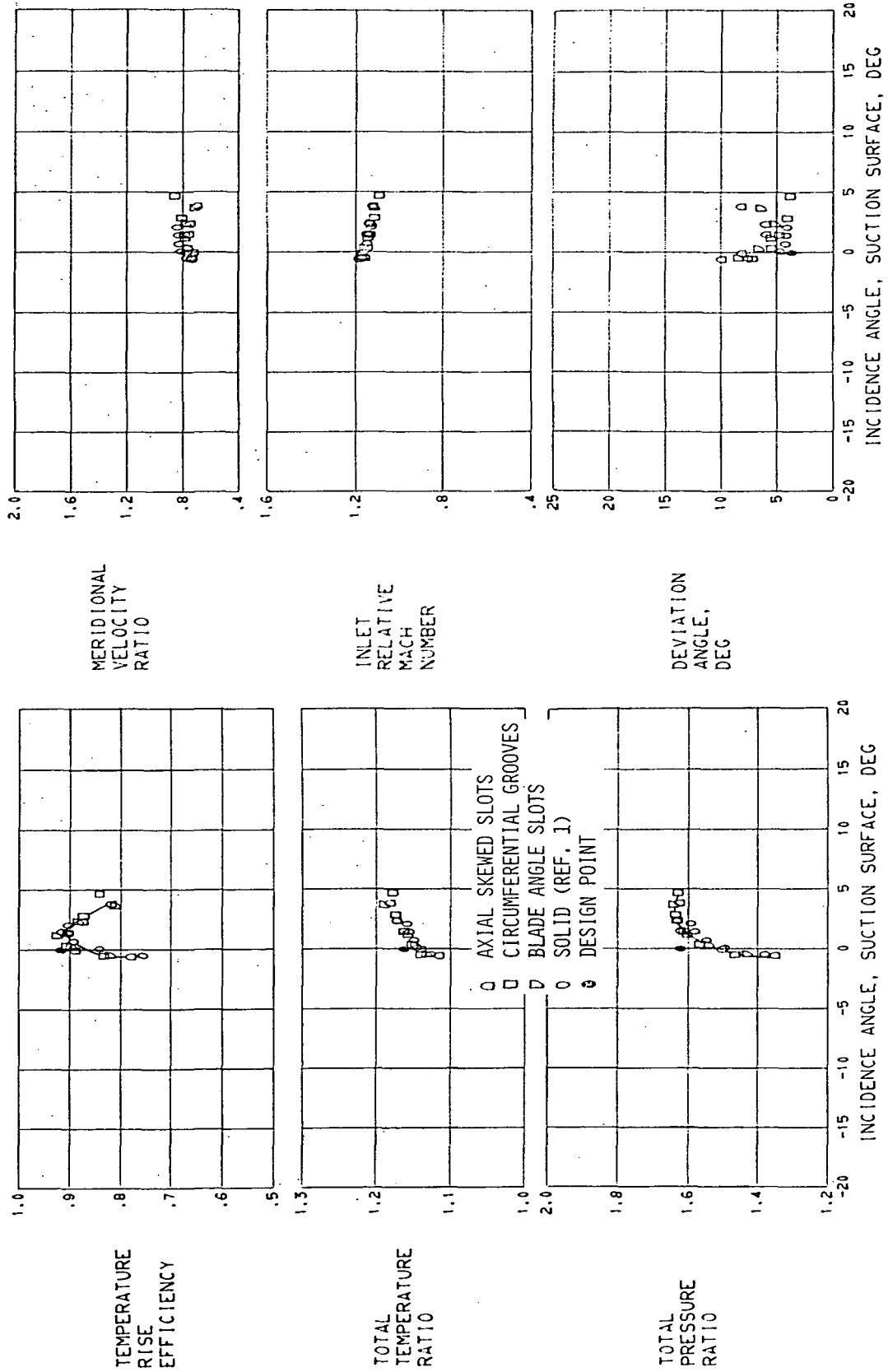

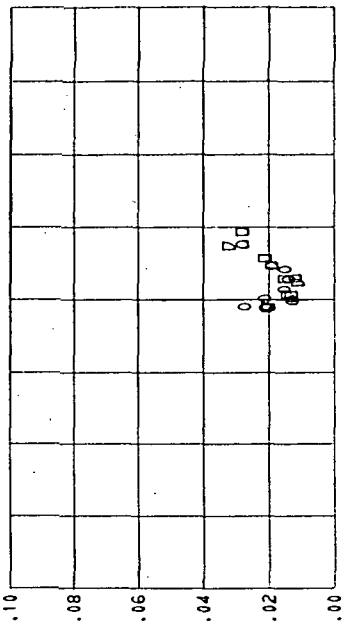

TOTAL
LOSS
PARAMETER

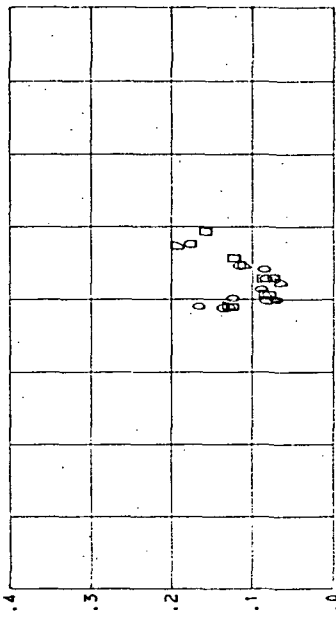

TOTAL
LOSS
COEFFICIENT

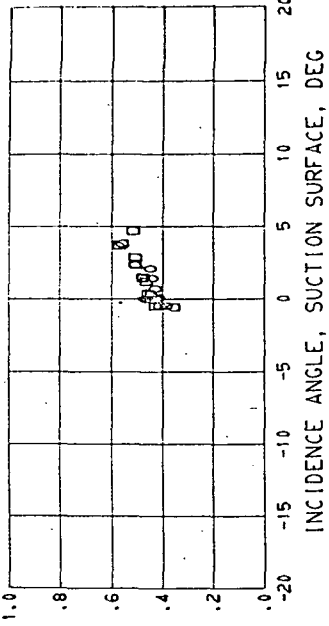

DIFFUSION
FACTOR

INCIDENCE ANGLE, SUCTION SURFACE, DEG

(D) 50.0 PERCENT SPAN.

FIGURE 17. - CONTINUED, BLADE-ELEMENT PERFORMANCE FOR ROTOR.

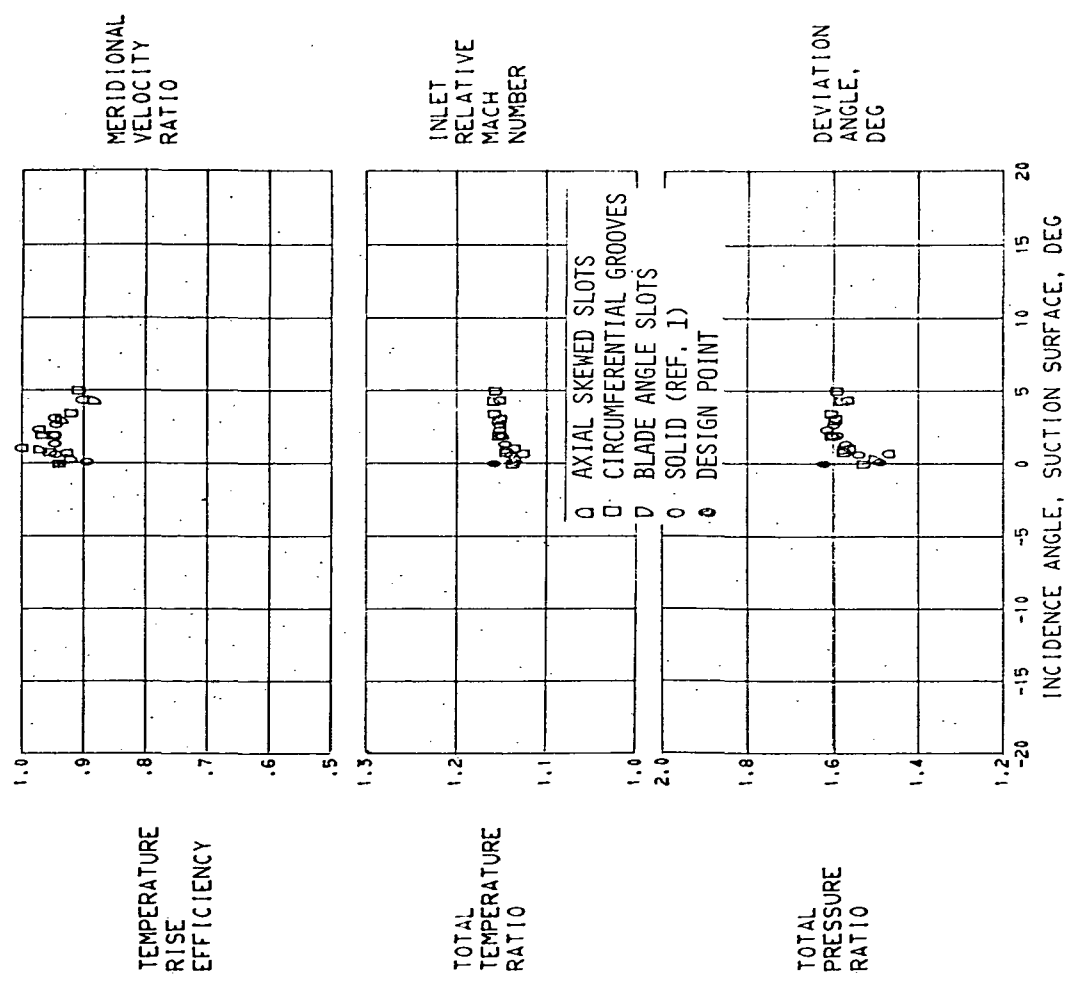
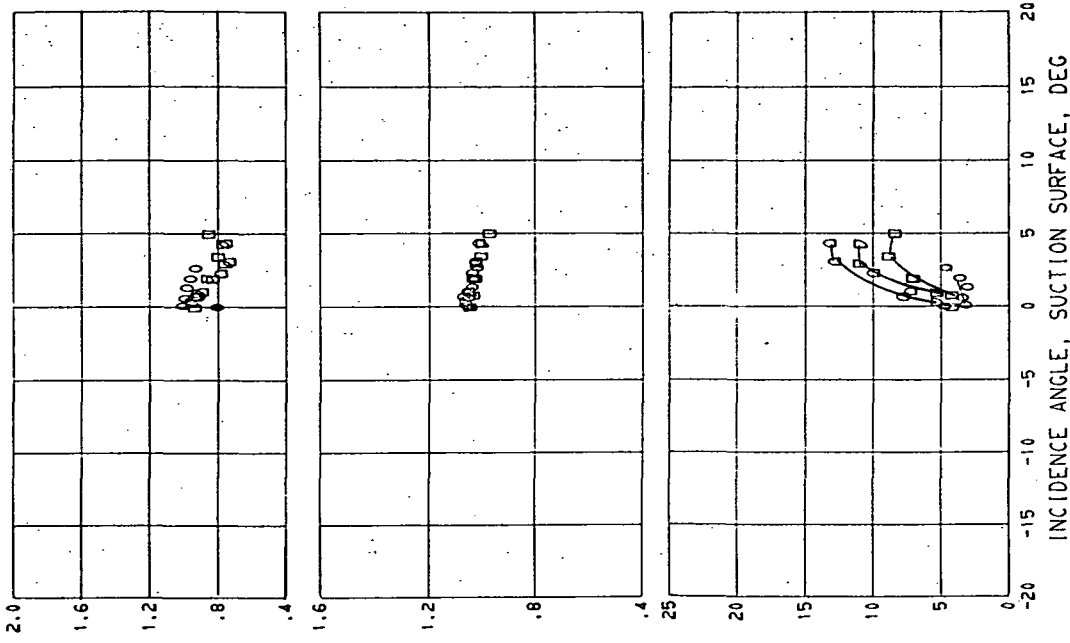

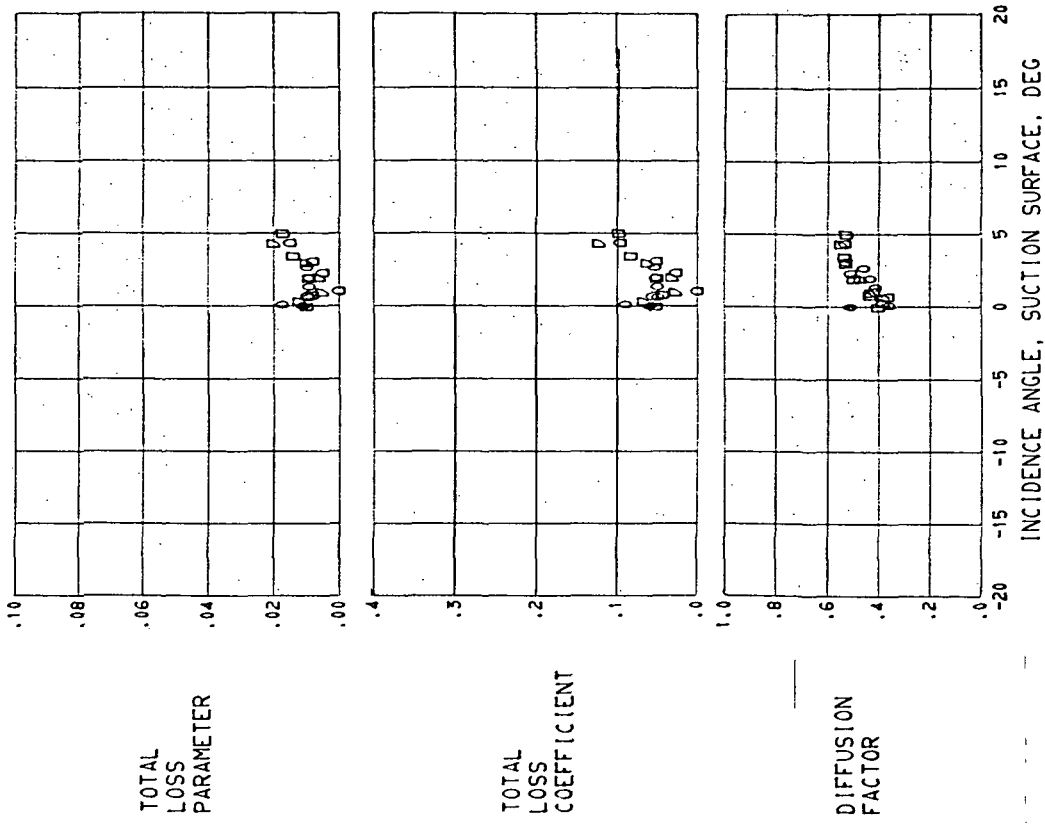

(E) 70.0 PERCENT SPAN.

FIGURE 17. - CONTINUED. BLADE-ELEMENT PERFORMANCE FOR ROTOR.

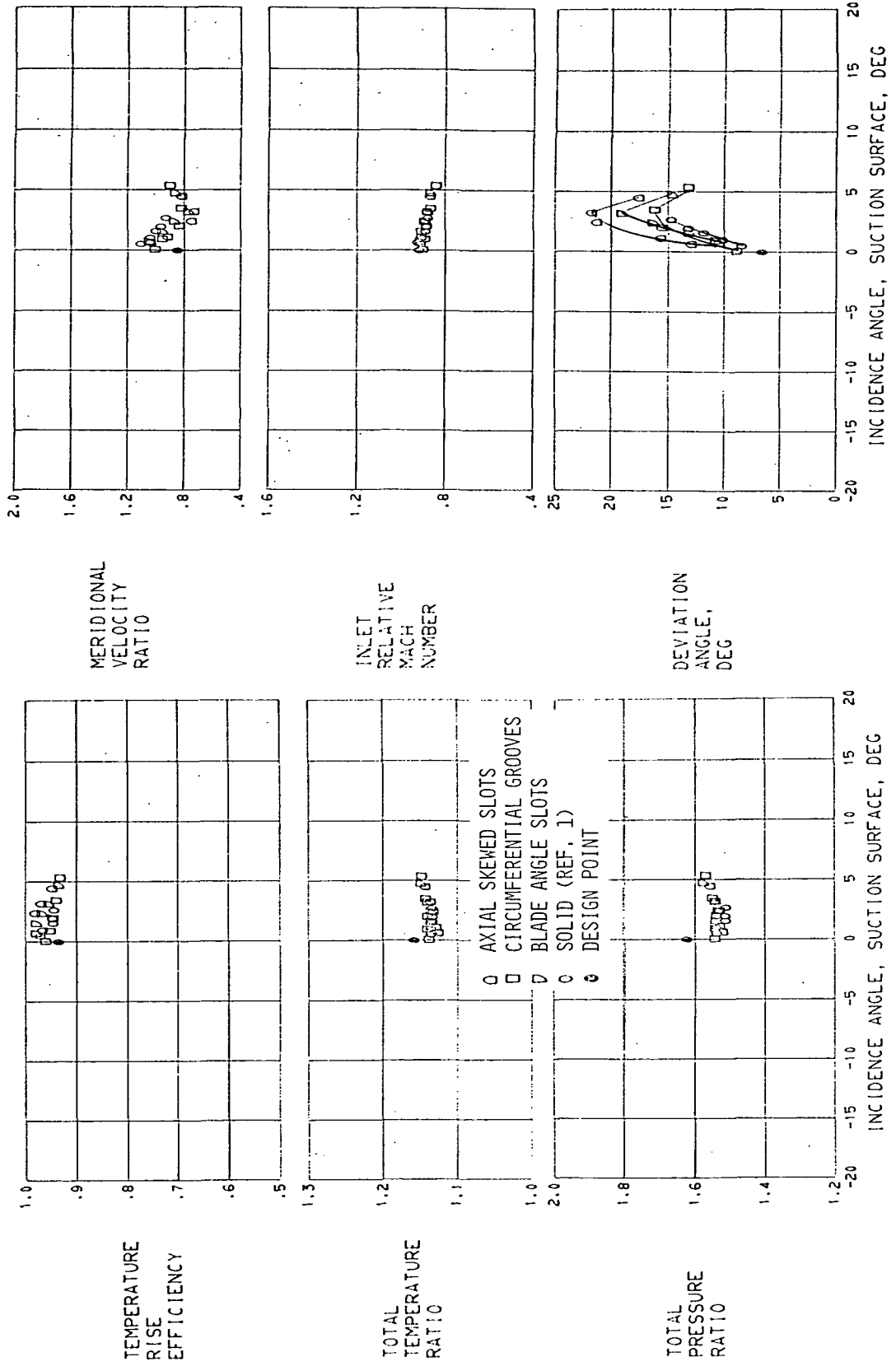

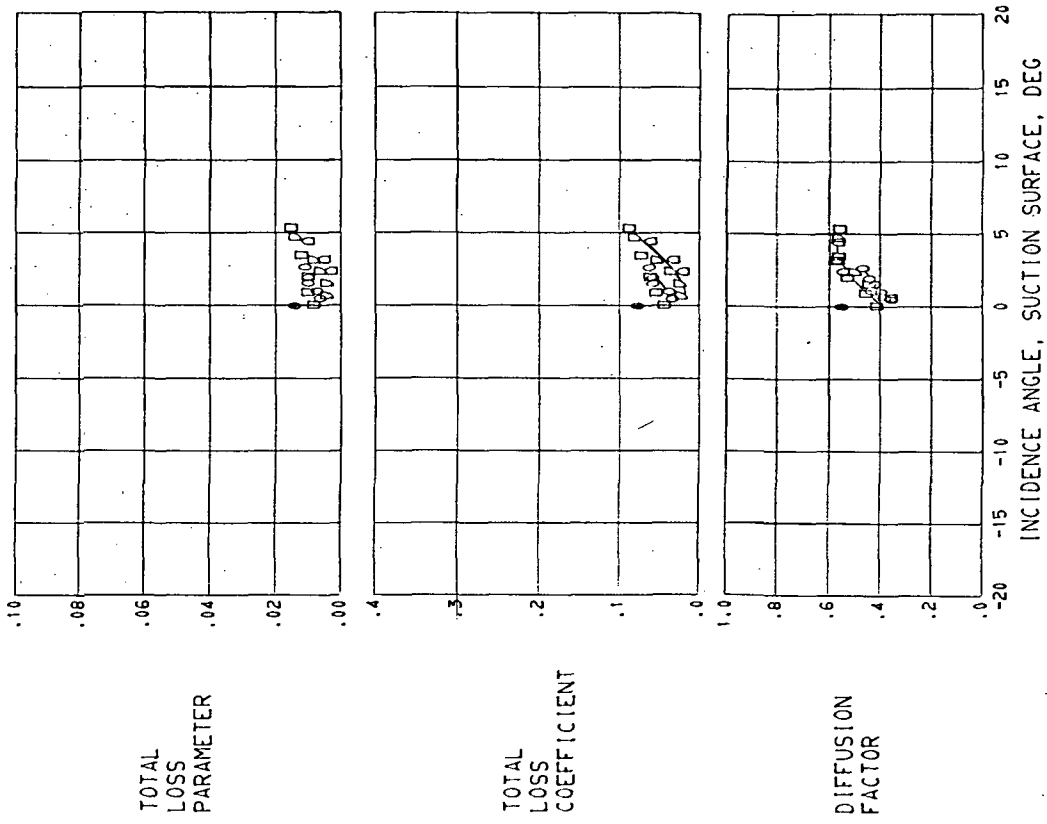

(F) 90.0 PERCENT SPAN.

FIGURE 17. - CONTINUED. BLADE-ELEMENT PERFORMANCE FOR ROTOR.

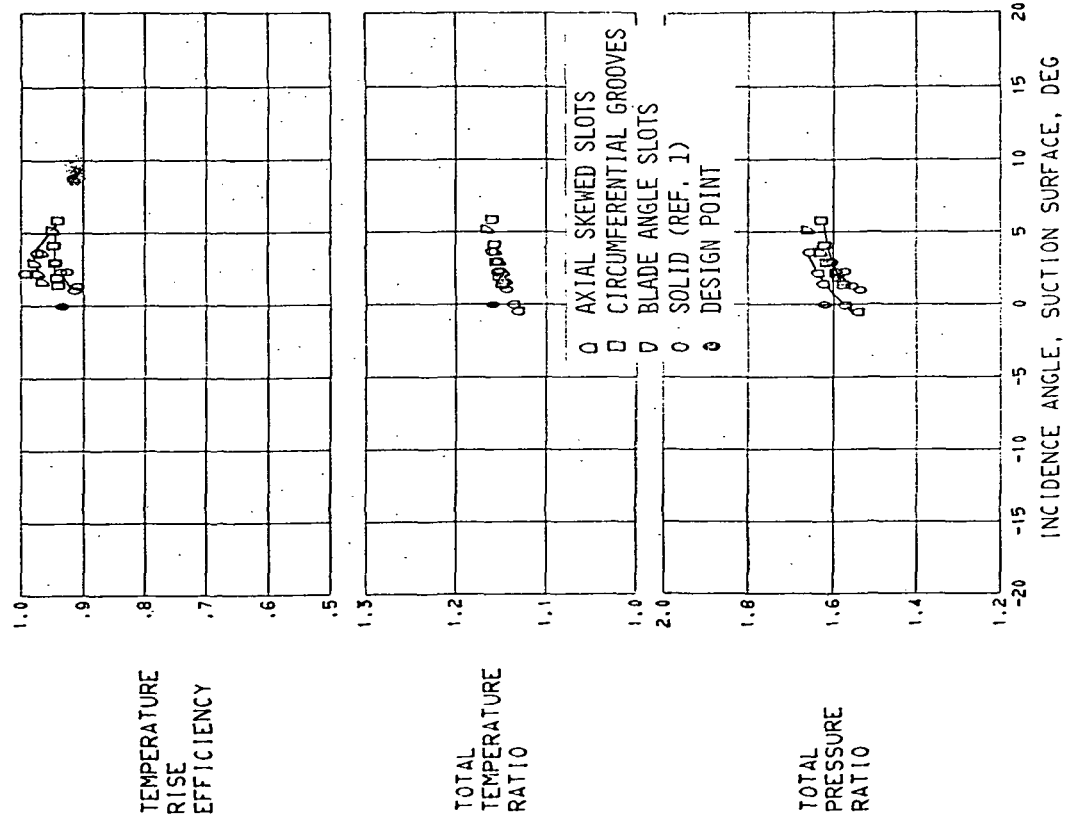
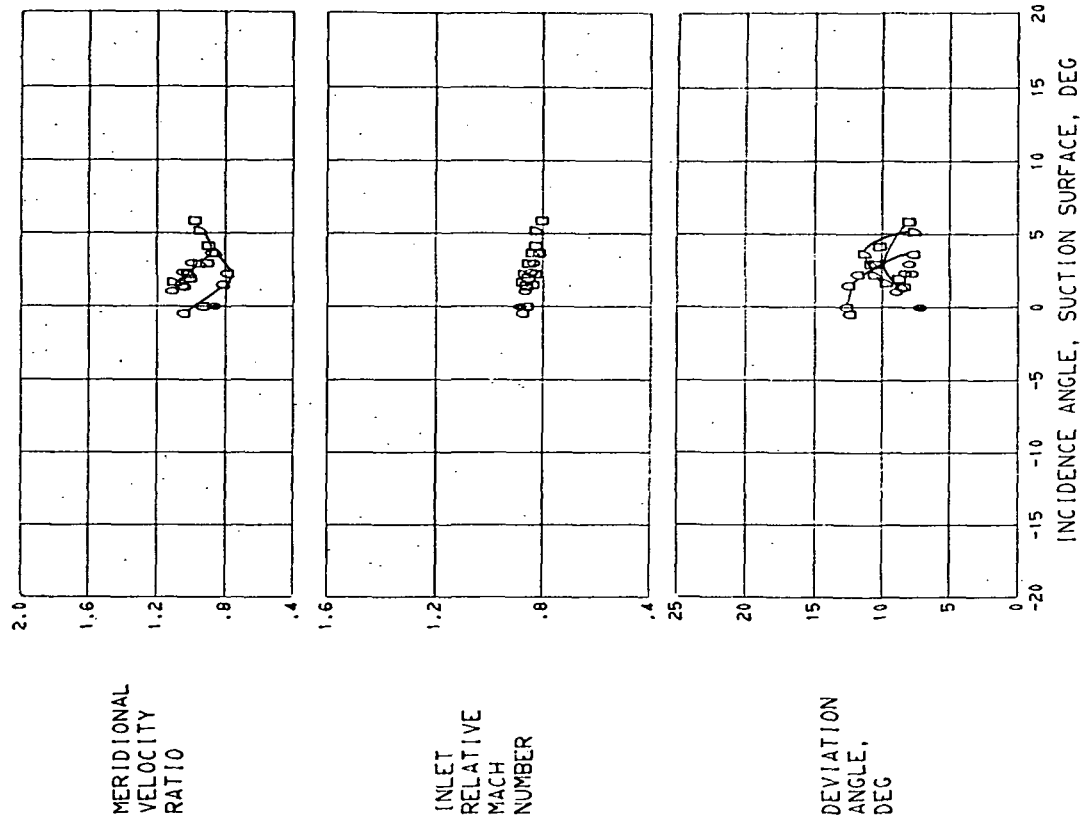

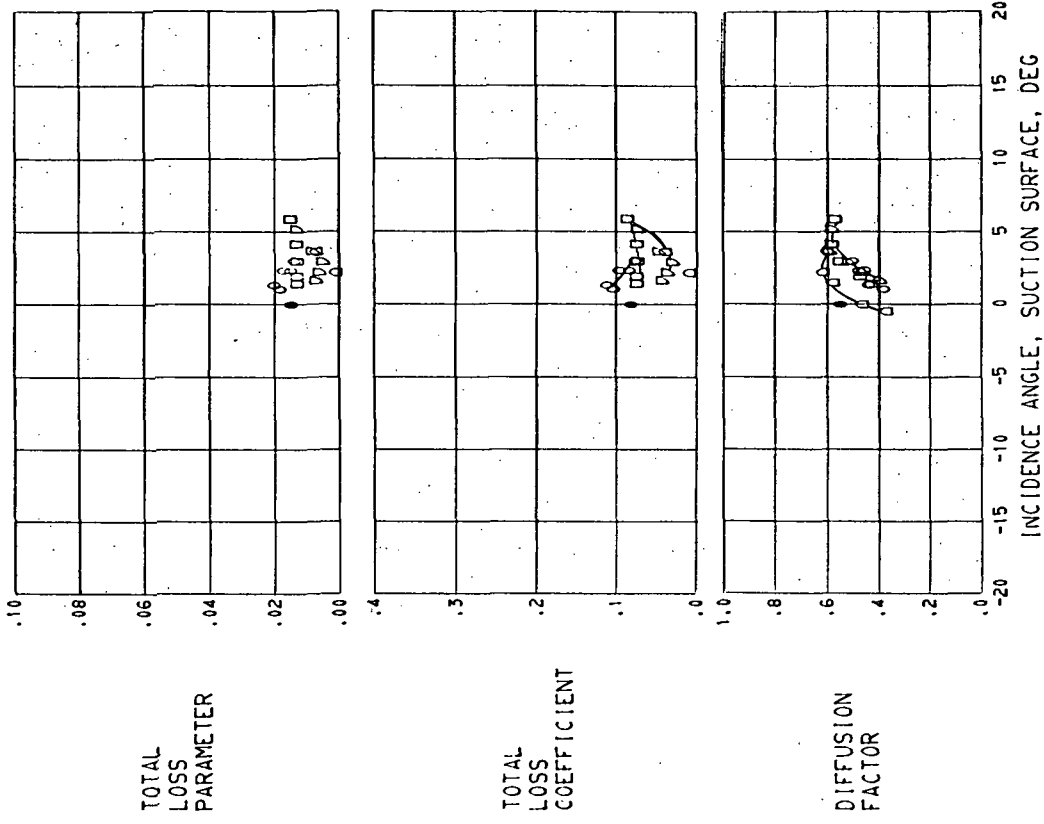

(G) 95.0 PERCENT SPAN.

FIGURE 17. - CONCLUDED. BLADE-ELEMENT PERFORMANCE FOR ROTOR.

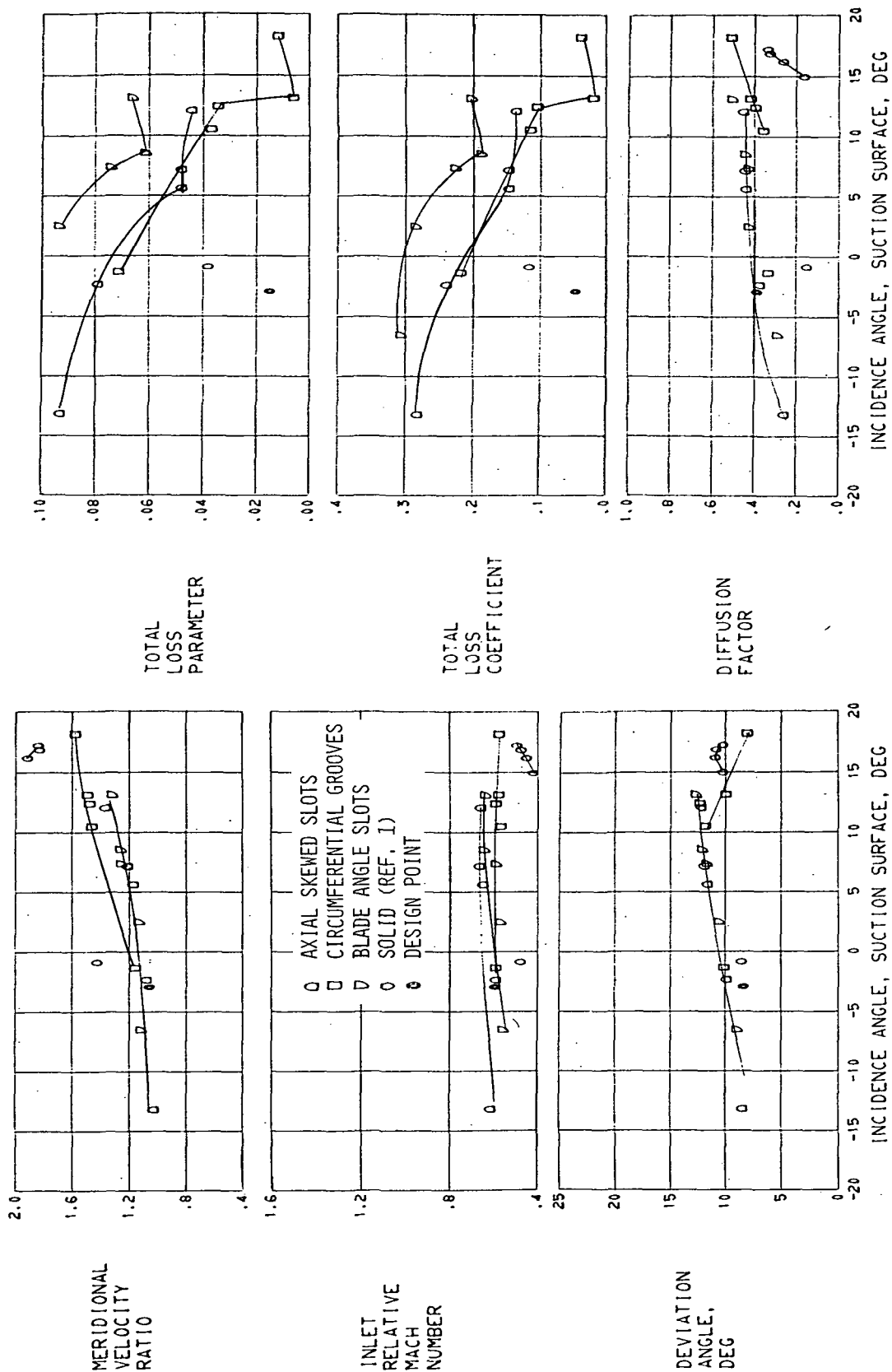

(A) 5.0 PERCENT SPAN.

FIGURE 18. - BLADE-ELEMENT PERFORMANCE FOR STATOR.

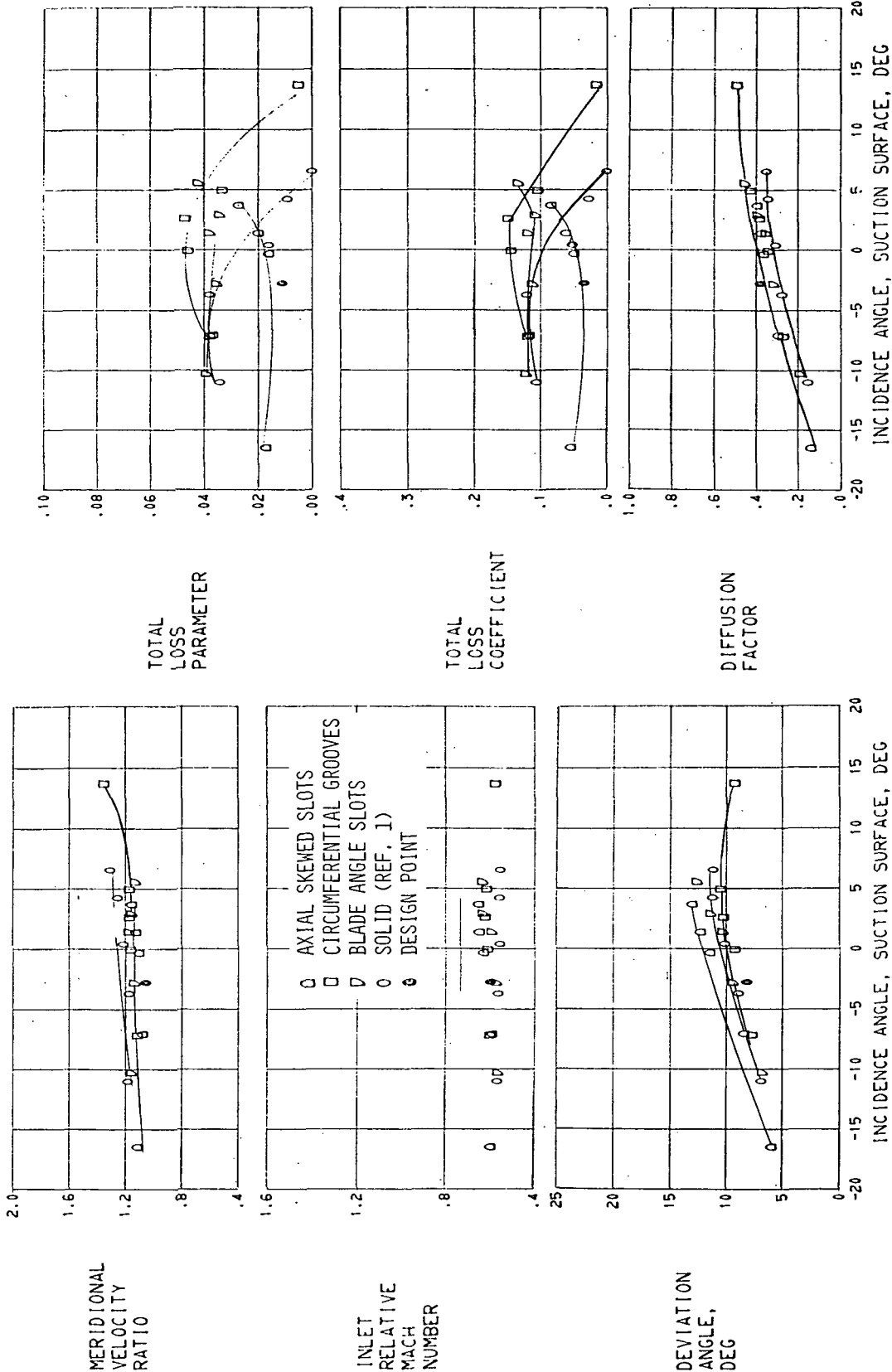

(B) 10.0 PERCENT SPAN.

FIGURE 18. - CONTINUED, BLADE-ELEMENT PERFORMANCE FOR STATOR.

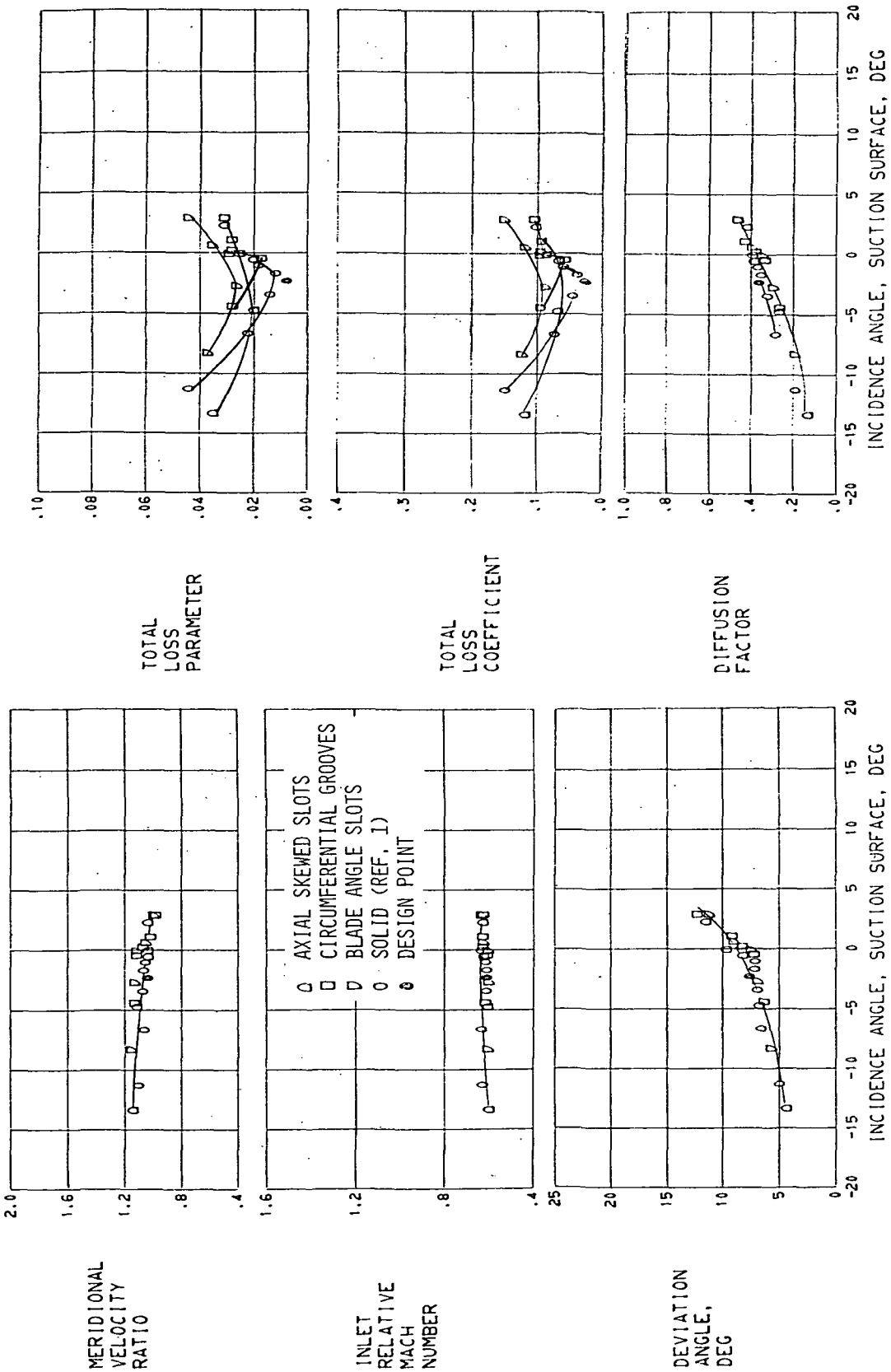

(C) 30.0 PERCENT SPAN.

FIGURE 18. - CONTINUED. BLADE-ELEMENT PERFORMANCE FOR STATOR.

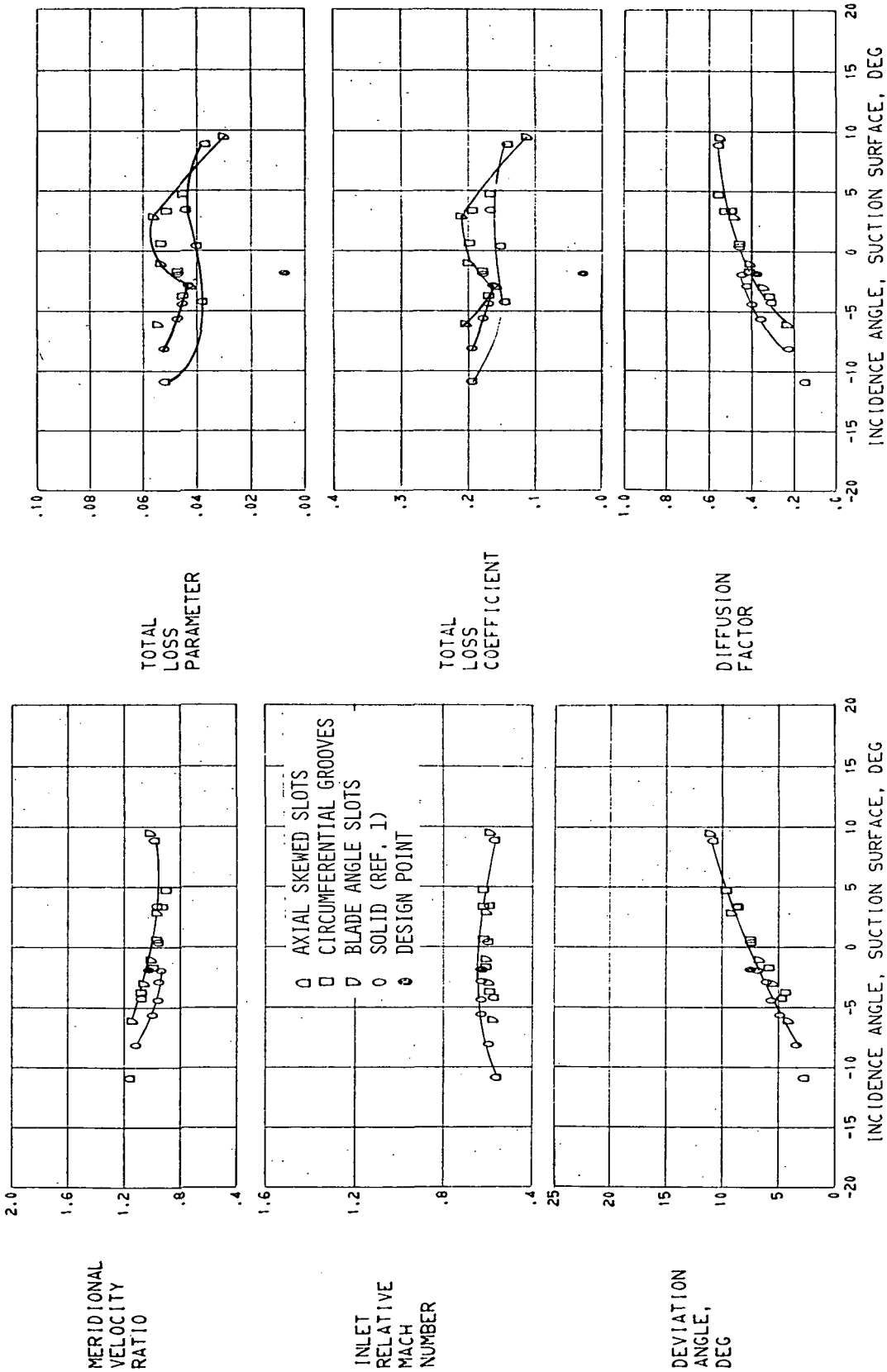

(D) 50.0 PERCENT SPAN.

FIGURE 18. - CONTINUED. BLADE-ELEMENT PERFORMANCE FOR STATOR,

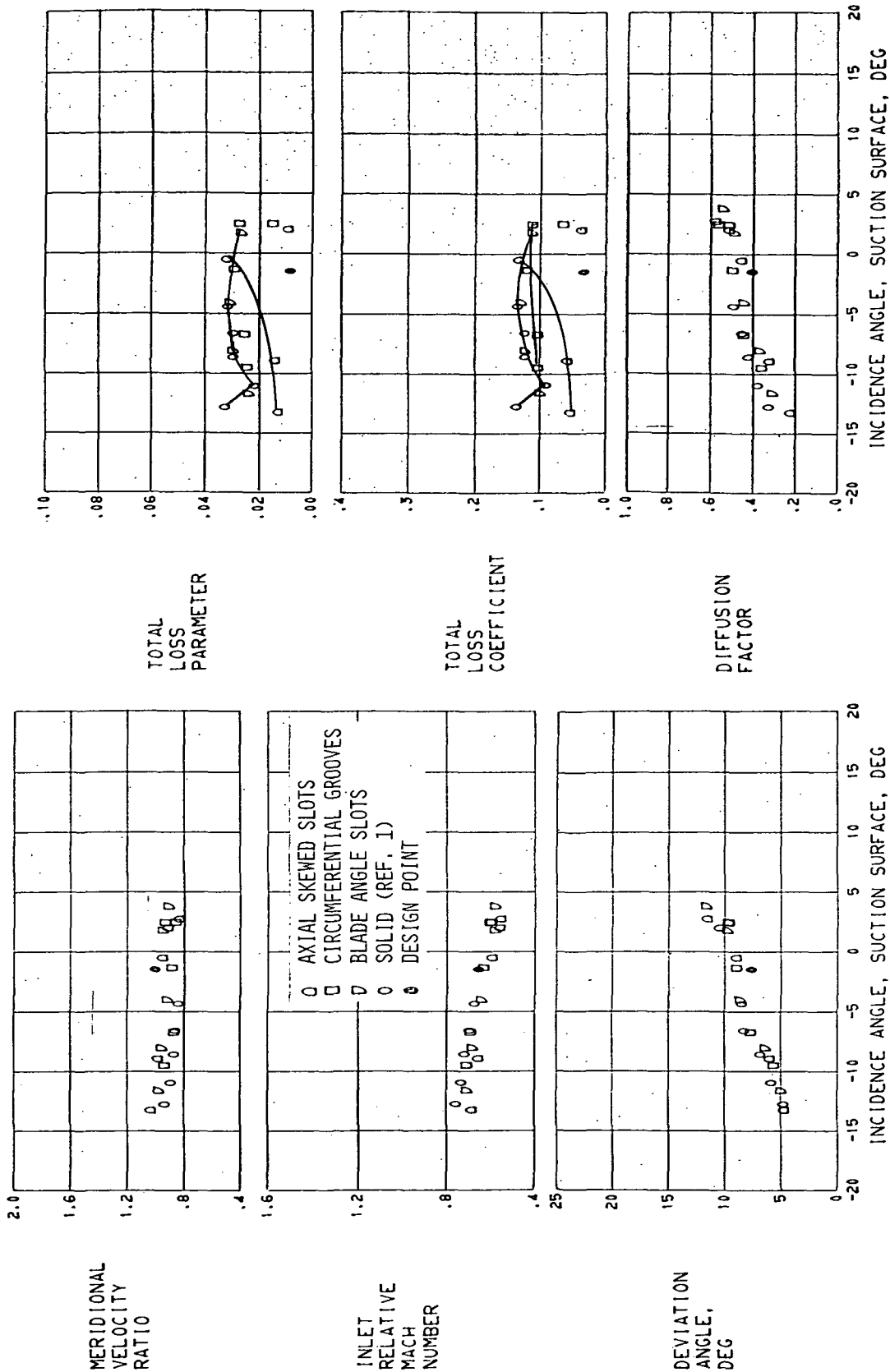

(E) 70.0 PERCENT SPAN.

FIGURE 18. - CONTINUED. BLADE-ELEMENT PERFORMANCE FOR STATOR.

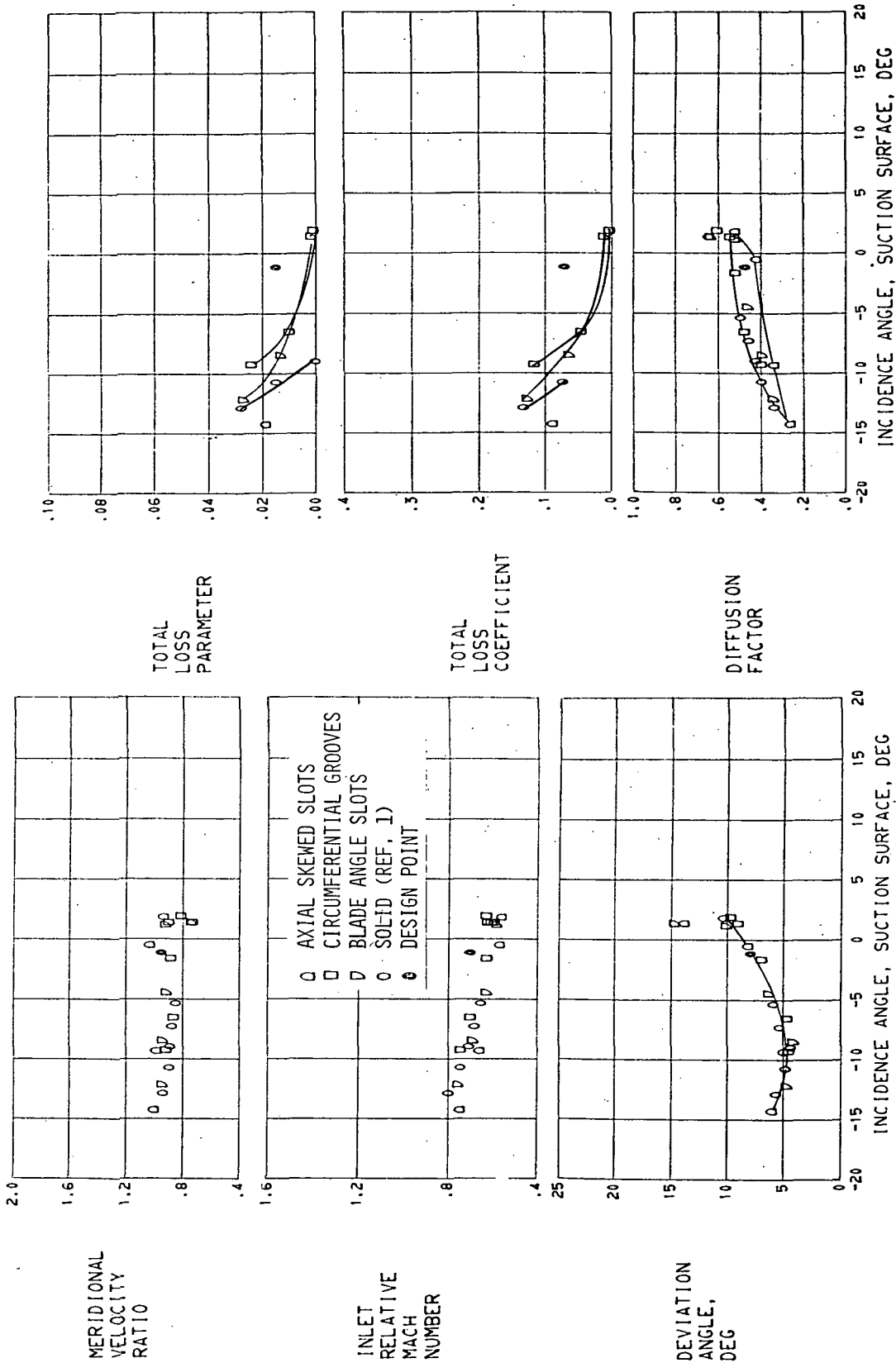

(F) 90.0 PERCENT SPAN.

FIGURE 18. - CONTINUED. BLADE-ELEMENT PERFORMANCE FOR STATOR.

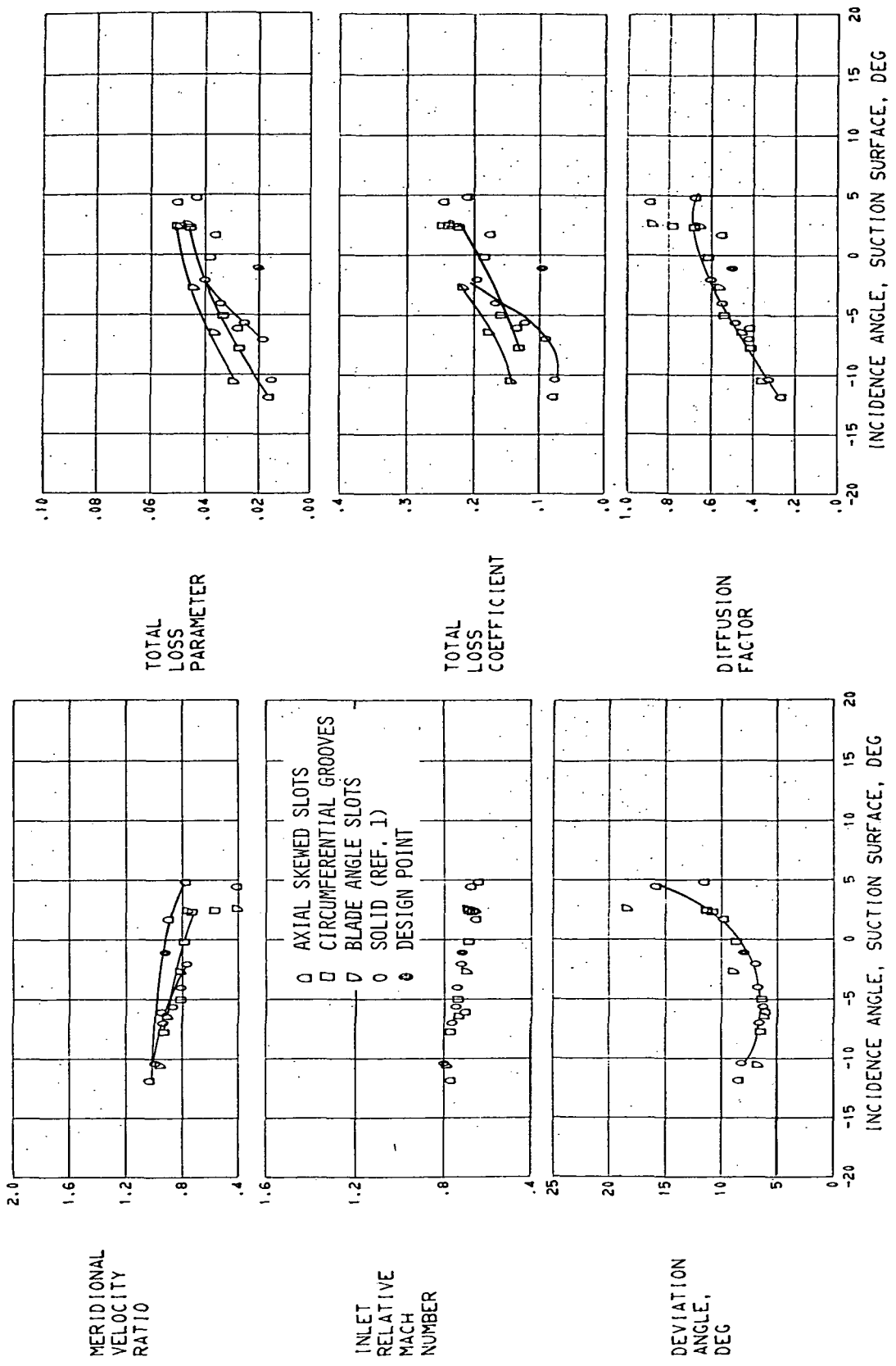

(G) 95.0 PERCENT SPAN.

FIGURE 18. - CONCLUDED. BLADE-ELEMENT PERFORMANCE FOR STATOR.



POSTMASTER: If Undeliverable (Section 158
Postal Manual) Do Not Return

"The aeronautical and space activities of the United States shall be conducted so as to contribute . . . to the expansion of human knowledge of phenomena in the atmosphere and space. The Administration shall provide for the widest practicable and appropriate dissemination of information concerning its activities and the results thereof."

—NATIONAL AERONAUTICS AND SPACE ACT OF 1958

NASA SCIENTIFIC AND TECHNICAL PUBLICATIONS

TECHNICAL REPORTS: Scientific and technical information considered important, complete, and a lasting contribution to existing knowledge.

TECHNICAL NOTES: Information less broad in scope but nevertheless of importance as a contribution to existing knowledge.

TECHNICAL MEMORANDUMS: Information receiving limited distribution because of preliminary data, security classification, or other reasons. Also includes conference proceedings with either limited or unlimited distribution.

CONTRACTOR REPORTS: Scientific and technical information generated under a NASA contract or grant and considered an important contribution to existing knowledge.

TECHNICAL TRANSLATIONS: Information published in a foreign language considered to merit NASA distribution in English.

SPECIAL PUBLICATIONS: Information derived from or of value to NASA activities. Publications include final reports of major projects, monographs, data compilations, handbooks, sourcebooks, and special bibliographies.

TECHNOLOGY UTILIZATION PUBLICATIONS: Information on technology used by NASA that may be of particular interest in commercial and other non-aerospace applications. Publications include Tech Briefs, Technology Utilization Reports and Technology Surveys.

Details on the availability of these publications may be obtained from:

**SCIENTIFIC AND TECHNICAL INFORMATION OFFICE
NATIONAL AERONAUTICS AND SPACE ADMINISTRATION
Washington, D.C. 20546**