

76-14335

REPRODUCIBLE COPY (FACILITY CASEFILE COPY)

ASI-TR-75-22
(NASA CR-132721)

N76-18095

File with N76-180' 5

FLIGHT TEST AND EVALUATION OF OMEGA NAVIGATION IN A GENERAL AVIATION AIRCRAFT

VOLUME II: APPENDICES
FINAL REPORT
April, 1975

Jack D. Howell
William C. Hoffman
Aerospace Systems, Inc.

Peter V. Hwoschinsky
C. Edward Wischmeyer
Massachusetts Institute of Technology

Contract No. NAS 1-13644
National Aeronautics and Space Administration

ASI

AEROSPACE SYSTEMS, INC.
ONE VINE BROOK PARK • BURLINGTON, MASS. 01803 USA
TELEPHONE (617) 272-7517

9.

FLIGHT TEST AND EVALUATION
OF
OMEGA NAVIGATION
IN A
GENERAL AVIATION AIRCRAFT

Volume II: Appendices

FINAL REPORT

by

Jack D. Howell
William C. Hoffman
Aerospace Systems, Inc.

and

Peter V. Hwoschinsky
C. Edward Wischmeyer
Massachusetts Institute of Technology

Approved



John Zvara
Technical Director

Prepared under
Contract No. NAS 1-13644

for

National Aeronautics and Space Administration
Hampton, Virginia 23365

April 1975

FOREWORD

A low-cost Flight Evaluation of Omega Navigation in a general aviation aircraft has been completed by Aerospace Systems, Inc. (ASI) as prime contractor with support from the MIT Flight Transportation Laboratory. Volume I: Technical, describes this evaluation in detail and refers to the four appendices contained in Volume II.

The Flight Evaluation Program consisted of two major parts: Part One—flights in the area of the NASA Wallops Flight Center and Part Two—flights in the Boston-New York-Washington corridor. Appendix A of this volume contains detailed documentation for each flight of Part One, including a flight test description sheet and actual flight data plots. Appendix B contains the same information for each flight of Part Two.

Various programs and data formats were required to carry out the Omega Flight Evaluation study. Appendix C explains the nine programs used for data processing and flight planning for this study and Appendix D summarizes the data formats utilized by the Custom Interface Unit (CIU).

TABLE OF CONTENTS

<u>Appendix</u>		<u>Page</u>
A	PLOTS OF WALLOPS AREA FLIGHT DATA	A-2
	A.1 Explanation of Flight Data Plots	A-2
B	PLOTS FOR NORTHEAST CORRIDOR FLIGHT DATA	B-2
	B.1 Explanation of Flight Data Plots	B-2
C	DATA REDUCTION SOFTWARE	C-1
	C.1 Introduction	C-1
	C.2 Program LOPFMLL	C-1
	C.3 Program LLFMLOP	C-1
	C.3.1 Program Description	C-1
	C.3.2 Derivation of Gradient Matrix	C-2
	C.4 Program TRNSFR7+	C-6
	C.5 Program DATACHK	C-7
	C.6 Program TRNSCHK	C-9
	C.7 Programs SNPLOTB and SNPLOTD	C-9
	C.8 Program SNPLOTC	C-12
	C.8.1 S/N Subroutine	C-14
	C.8.2 Needle Deflection Subroutine	C-14
	C.9 Program SNPLOTE	C-14
	C.10 Program WALPLOT	C-15
D	CUSTOM INTERFACE UNIT (CIU) DATA FORMAT	D-1
	D.1 Character Sequence	D-1
	D.2 Character Format	D-2
	D.3 Data Format	D-2

APPENDIX A

PLOTS OF WALLOPS AREA FLIGHT DATA

APPENDIX A

PLOTS OF WALLOPS AREA FLIGHT DATA

A.1 EXPLANATION OF FLIGHT DATA PLOTS

Most flights have several sheets of documentation. Each flight has a flight test description sheet, and most flights have data from the flight consisting of an Omega indication sheet with miles to go readout, receiver status flags, and needle deflection; plus additional sheets containing S/N ratio plots for selected stations.

The flight test description sheet has four sections: flight objectives, pertinent information, summary, and key words. The flight objectives section describes the reasons for making the flight, i.e., what data was to be collected, and phenomena to be observed. The pertinent information section contains the date, departure point, route, altitude, destination, and weather. The summary is a paragraph description of the flight, describing operational procedures, effects observed, and quality of the data. Key words provide a quick reference for comparing the various anomalies observed on each flight.

The Omega indication sheet contains various parameters plotted against time. These parameters are the miles to go (MTG) readout, plotted on a scale of 0-75 miles, four status flags, and the needle deflection. The four status flags are readouts of the to/from flag, activation of the autozero command in the past 10 seconds, activation of the lane accumulator reset in the past ten seconds, and occurrence of a weak signal light showing insufficient S/N ratio on a station used for navigation in the past 10 seconds. The needle deflection is that deflection indicated to the pilot, sampled every 10 seconds and based on data accumulated at the end of an Omega transmission cycle. Operator discrete code changes are plotted along the vertical axis to mark the occurrence of various events in synchronization with the data. From these ticks a time reference was generated, and times are labeled every ten minutes. The title of the figure is at the bottom of the page, and it tells what part of each flight was processed to provide the plotted data. In addition, the parameters plotted, the origin, route, date, and altitude of the flight are given, along with the time of the plotted data in both local and Greenwich time.

Other plots are S/N ratios of various stations as estimated by the Omega receiver. The S/N plots, described in the text, derive time axis and operator discrete code information from the same data base as the MTG and needle deflection plots. Thus, comparison of the various plots is simplified because all have identical vertical time axes.

GLOSSARY

ADF	Automatic Direction Finder
AGL	Above Ground Level (Altitude)
AZ	AutoZero
CCV	Cape Charles VOR
CDI	Course Deviation Indicator
CN	Course Number
EDT	Eastern Daylight Time
EST	Eastern Standard Time
GMT	Greenwich Mean Time
I	Island
ILS	Instrument Landing System
L-W	Land to Water
MFV	Melfa NDB
min	Minute
mod	Moderate
MSL	Mean Sea Level (Altitude)
MTG	Miles To Go
NDB	Non-Directional Radio Beacon
ORF	Norfolk VOR
R	Radial
Riv	River
RR	Railroad
Rte	Route
SBY	Salisbury VOR
S/N	Signal to Noise
str	Strong
SWL	Snow Hill VOR
TGI	Tangier Island NDB
VOR	Very High Frequency Omnidirectional Radio Range
WAL	Wallops Airports
wk	Weak
W-L	Water to Land
WSL	Weak Signal Light
WPT	Waypoint

TEST DESCRIPTION

Flight No. 1-0

TEST OBJECTIVES: Provide initial view of S/N ratios in the SWL VOR area.

DATE: 2/19/75

DEPARTURE: SBY, 1550 EST

DESTINATION: WAL

ROUTE: via SWL VOR

ALTITUDE: 1000'

WEATHER: VFR, 15 kts, SW

SUMMARY: First flight in the Snow Hill - Wallops area, initially along powerlines running South from Salisbury. Flew within one mile of the SWL VOR. No recorded data available.

KEY WORDS: Interference.

TEST DESCRIPTION

Flight No. 1-1

TEST OBJECTIVES: Provide initial area survey of Wallops and mid Delmarva peninsula at 5000' and selected lower altitudes with radar tracking.

DATE: 2/20/75 DEPARTURE: WAL, 1000 EST

DESTINATION: WAL ROUTE: Low altitude star

ALTITUDE: 5000' WEATHER: VFR

SUMMARY: Star route flown with radar tracking at 5000, 4000, 3000 and 2000 ft. Initial circuit flown at 5000' was: Wallops, Parksley, Wallops Coast Guard, Pocomoke, Metomkin Island, Saxis, Chincoteague Refuge, SWL VOR, and Wallops airport. Then each successive leg was flown 1000' lower.

KEY WORDS: Altitude, coast, interference, radar.

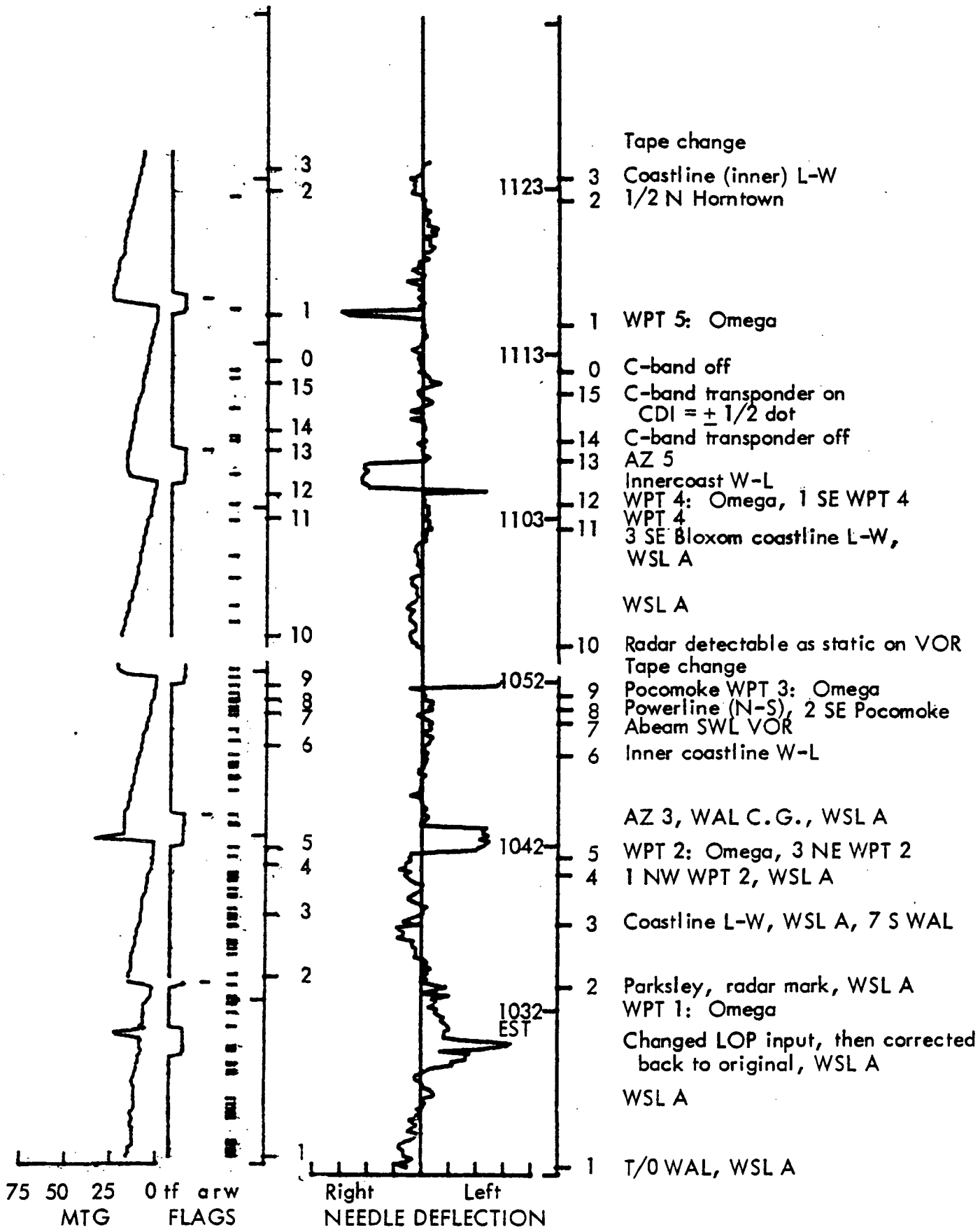

Figure A-1 . Flight 1-1 (First 62 Min.), Miles to Go and Needle Deflection;
WAL Low Alt Star, 2/20/75, 5000', 1020-1222 EST, 1520-1722 GMT.

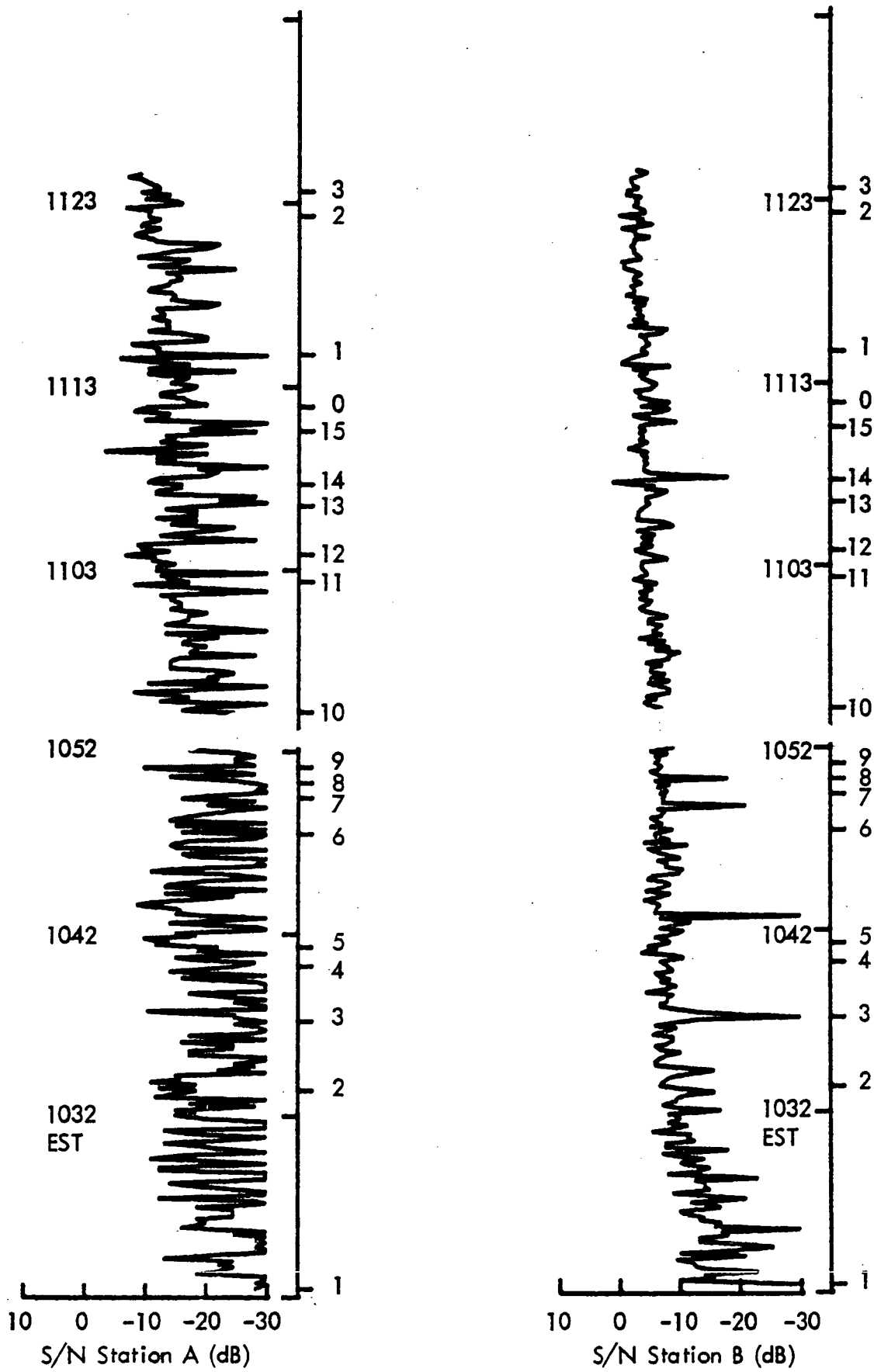

Figure A-2 . Flight 1-1 (First 62 Min.), S/N Station A and B;
 WAL Low Alt Star, 2/20/75, 5000', 1020-1222 EST, 1520-1722 GMT.

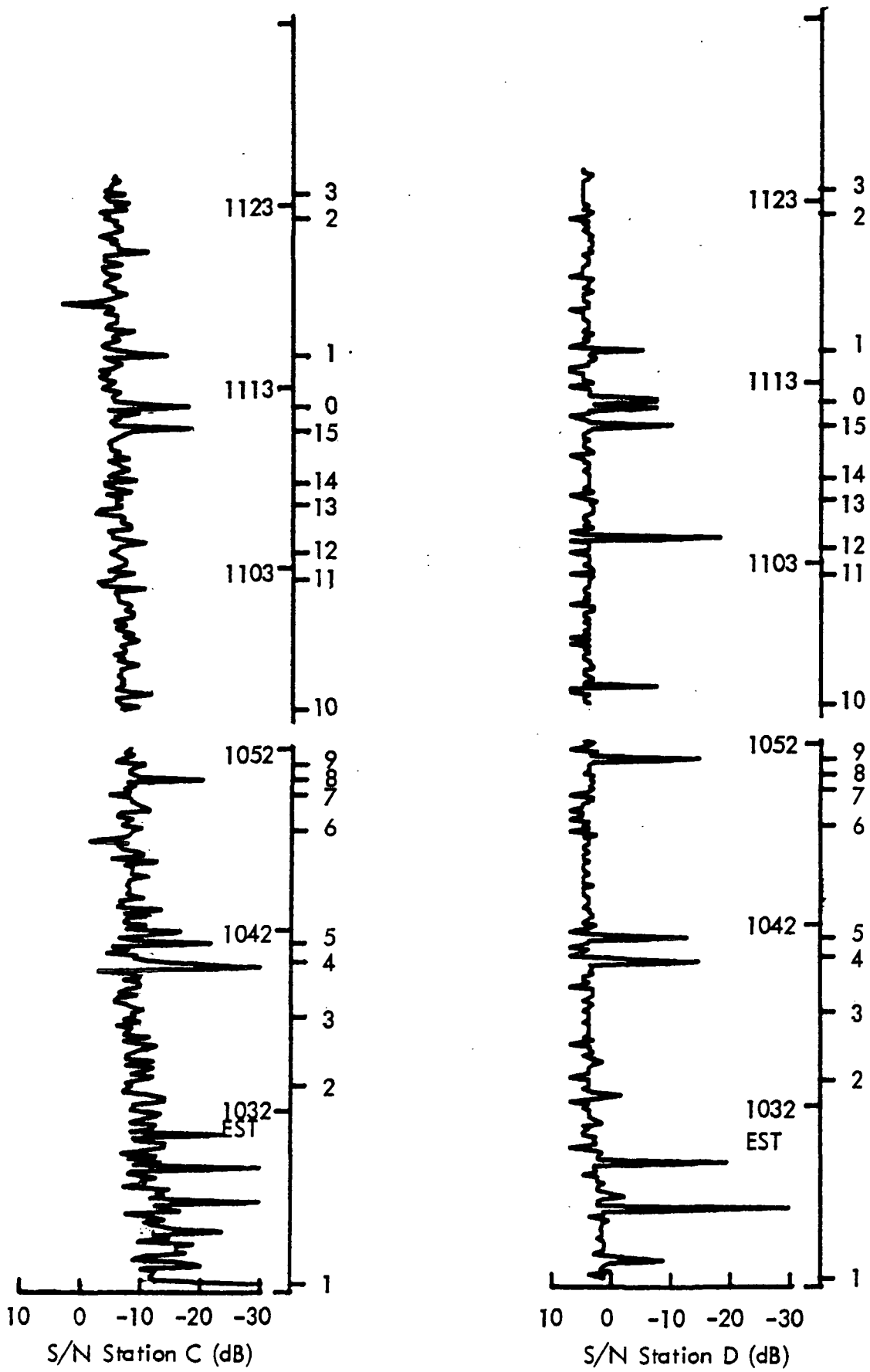

Figure A-3 . Flight 1-1 (First 62 Min.), S/N Station C and D;
 WAL Low Alt Star, 2/20/75, 5000', 1020-1222 EST, 1520-1722 GMT.

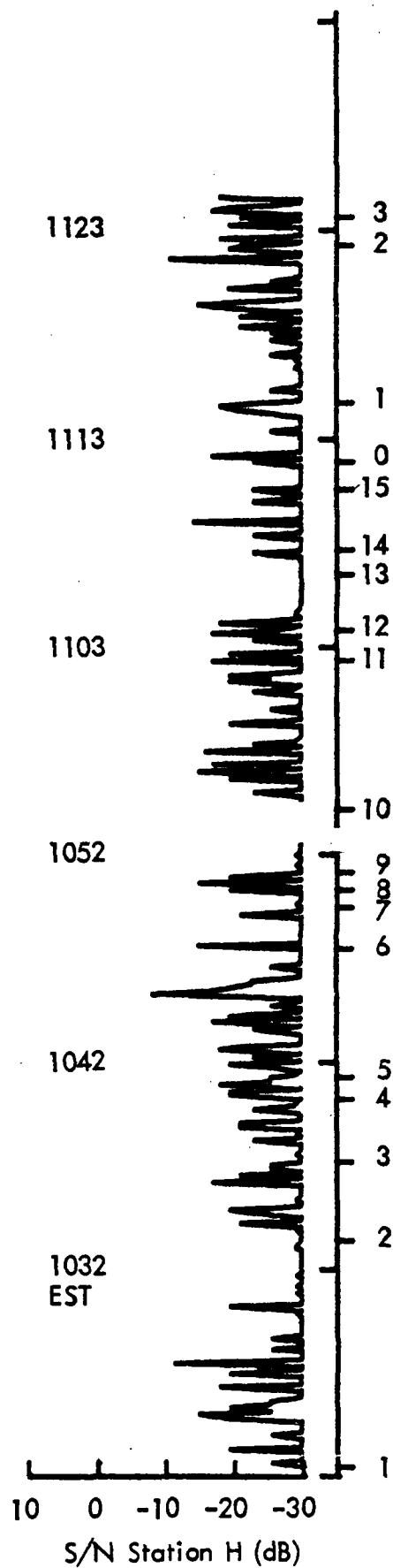

Figure A-4 . Flight 1-1 (First 62 Min.), S/N Station H.
 WAL Low Alt Star, 2/20/75, 5000', 1020-1222 EST, 1520-1722 GMT.

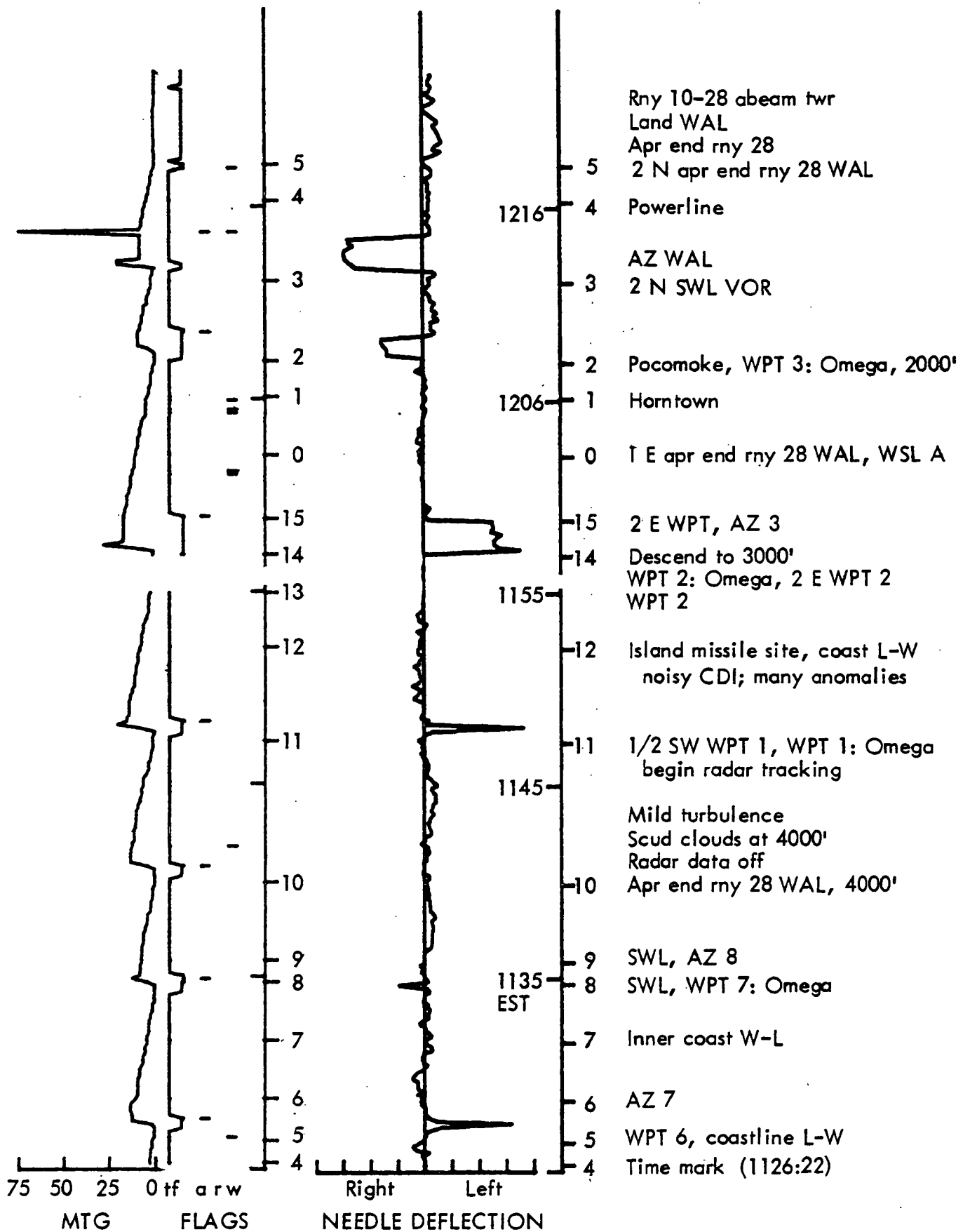

Figure A-5. Flight 1-1 (Second 58 Min.), Miles to Go and Needle Deflection; WAL Low Alt Star, 2/20/75, Vary Alt, 1020-1222 EST, 1520-1722 GMT.

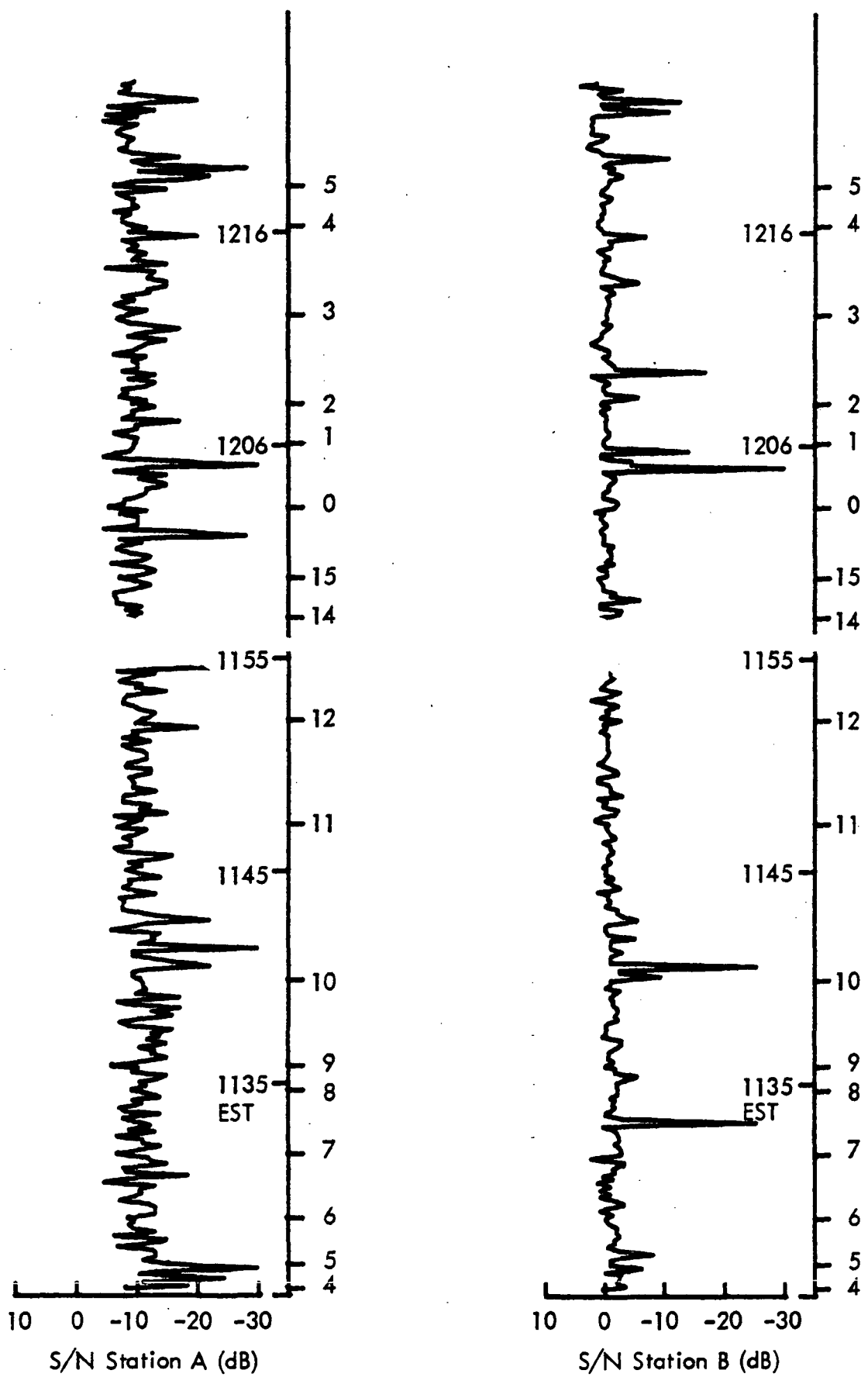

Figure A-6 . Flight 1-1 (Second 58 Min.), S/N Station A and B;
 WAL Low Alt Star, 2/20/75, Vary Alt, 1020-1222 EST, 1520-1722 GMT.

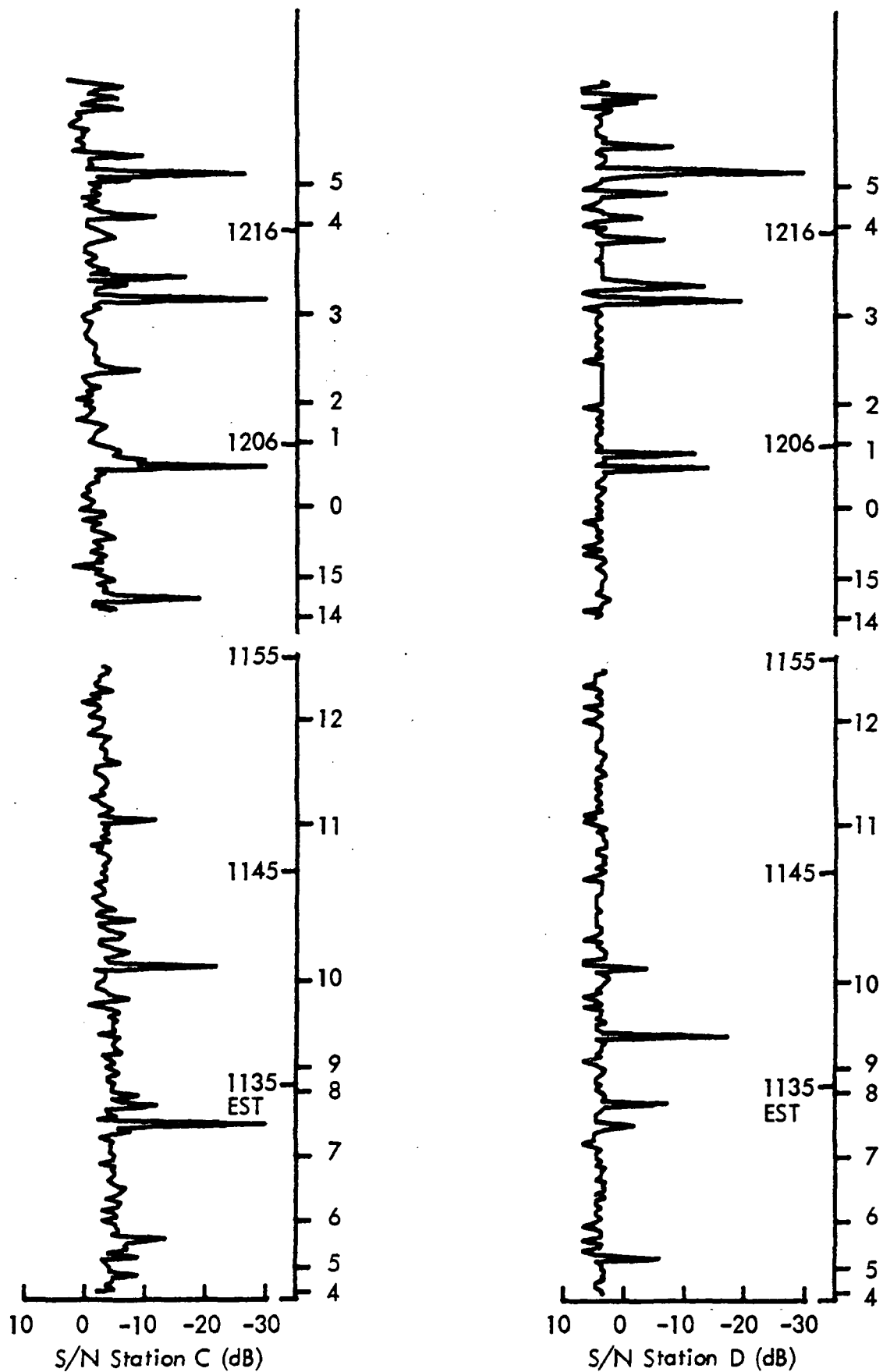

Figure A-7 . Flight 1-1 (Second 58 Min.), S/N Station C and D;
 WAL Low Alt Star, 2/20/75, Vary Alt, 1020-1222 EST, 1520-1722 GMT.

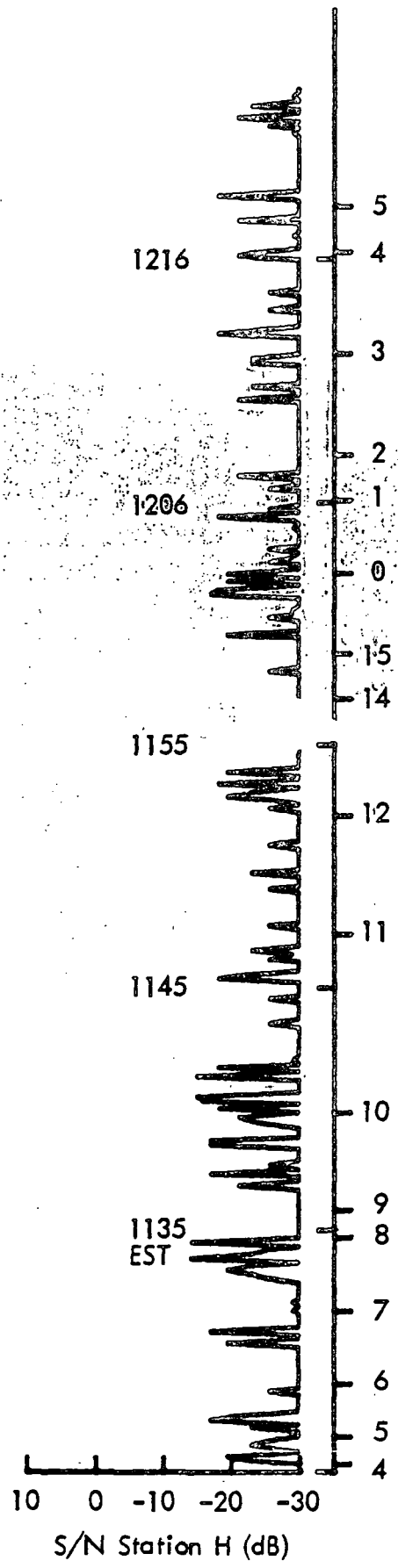

Figure A-8 . Flight 1-1 (Second 58 Min.), S/N Station H.
 WAL Low Alt Star, 2/20/75, Vary Alt, 1020-1222 EST, 1520-1722 GMT.

TEST DESCRIPTION

Flight No. 1-2

TEST OBJECTIVES: Obtain additional S/N data near SWL VOR.

DATE: 2/20/75

DEPARTURE: WAL, 1300 EST

DESTINATION: SBY

ROUTE: WAL - SBY

ALTITUDE: 1000'

WEATHER: VFR, 15 kts, NW

SUMMARY: Refueling flight along power line from Wallops to Salisbury.

KEY WORDS: Interference.

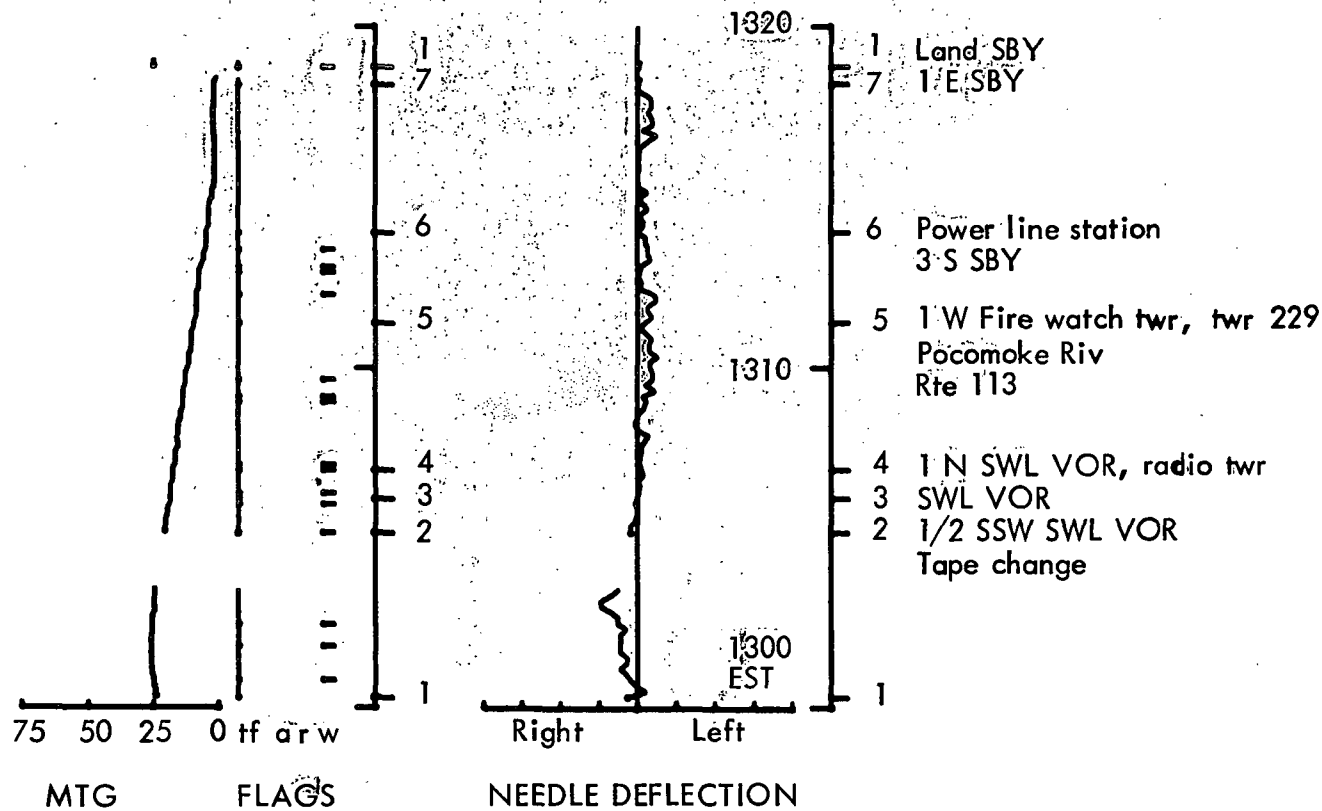
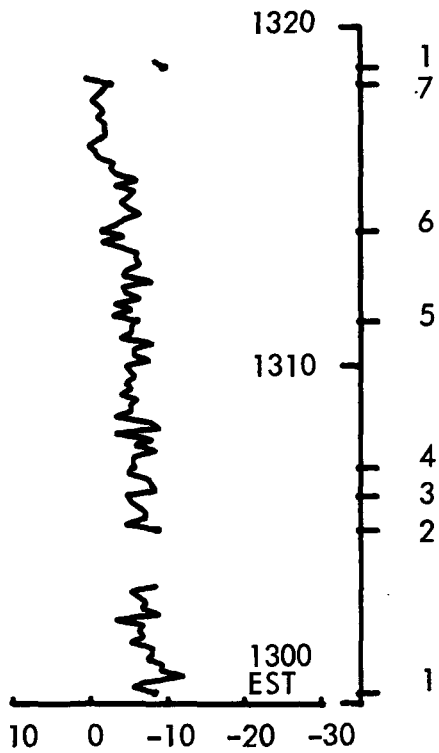
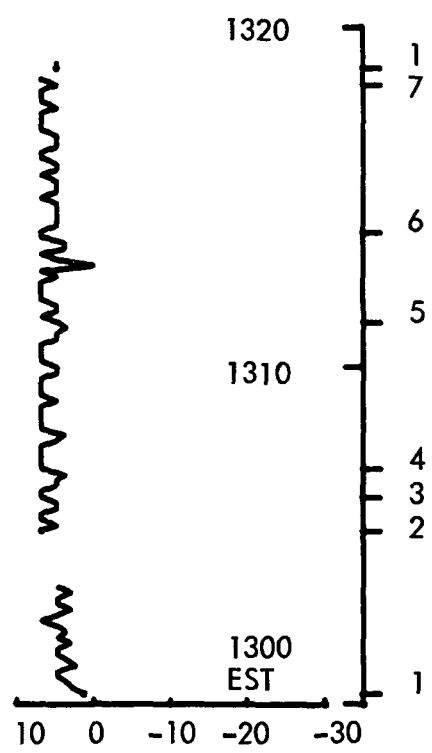

Figure A-9 . Flight 1-2, Miles to Go and Needle Deflection;
WAL-SBY, 2/20/75, 1000', 1259-1320 EST, 1759-1820 GMT.



S/N Station C (dB)



S/N Station D (dB)

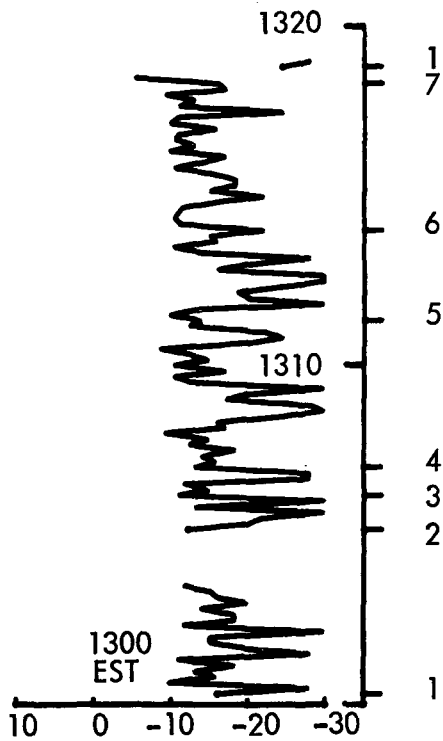

S/N Station A (dB)

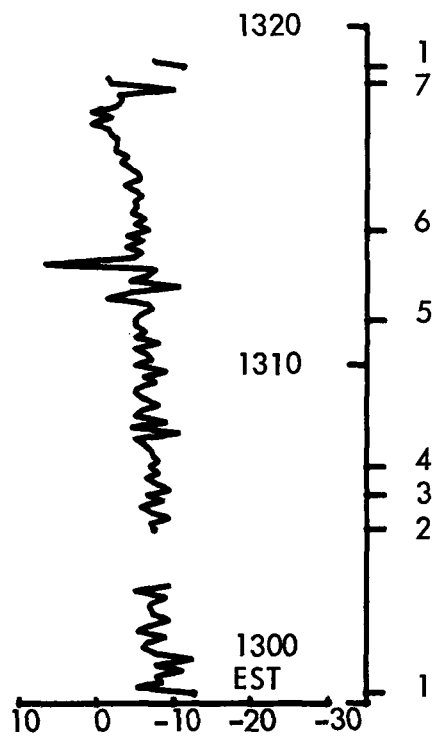

S/N Station B (dB)

Figure A-10 . Flight 1-2, S/N Station A, B, C and D;
WAL-SBY, 2/20/75, 1000', 1259-1320 EST, 1759-1820 GMT.

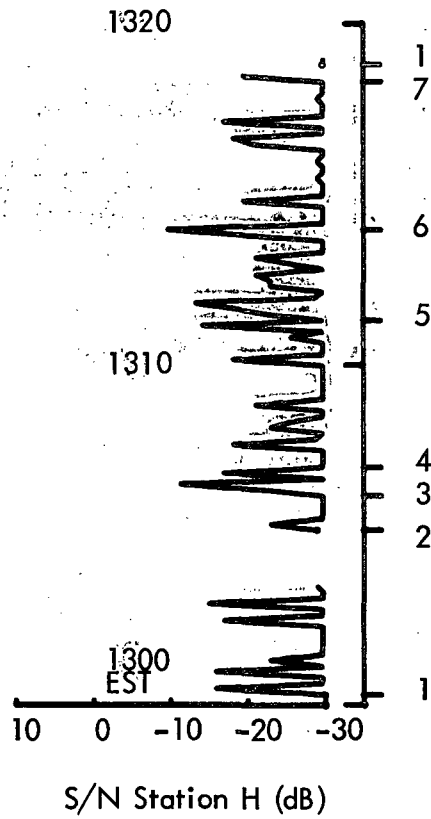

Figure A-11 . Flight 1-2, S/N Station H;
 WAL-SBY, 2/20/75, 1000', 1259-1320 EST, 1759-1820 GMT.

TEST DESCRIPTION

Flight No. 1-3

TEST OBJECTIVES: Obtain S/N plots in Wallops area at 10,000 with some flight segments at lower altitudes; radar coverage is provided (includes return trip from SBY).

DATE: 2/20/75

DEPARTURE: SBY, 1400 EST

DESTINATION: WAL

ROUTE: High Altitude Star

ALTITUDE: 10,000'

WEATHER: VFR with clouds at 4000'

SUMMARY: Flights made at 10,000' detected some shore effect. Route of flight was Salisbury, Ocean City, Crisfield, Hog Island, Snow Hill VOR, Watts Island, Wallops. Some noticeable effect of local interference appeared on CDI.

KEY WORDS: Altitude, coast, interference, radar.

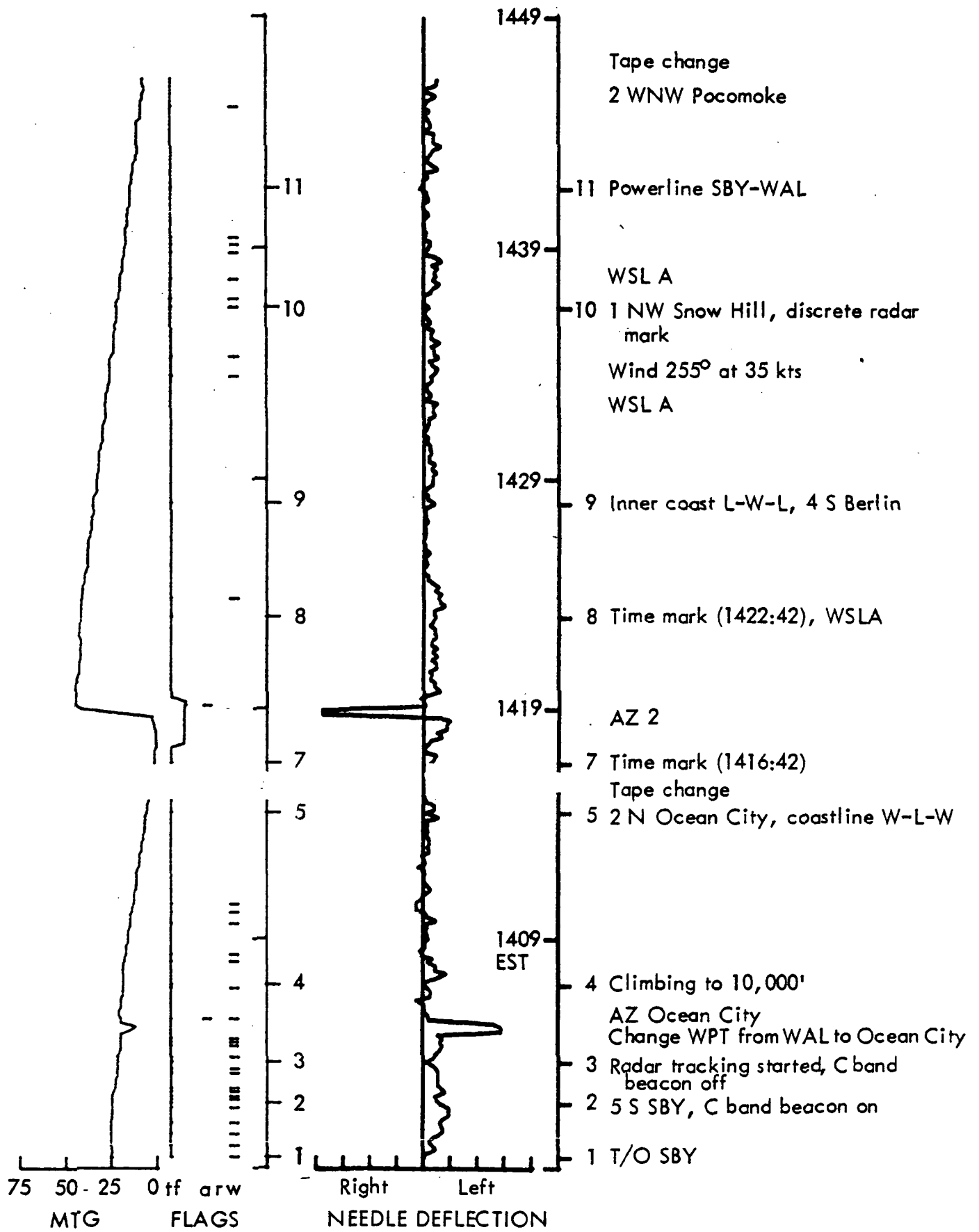

Figure A-12 . Flight 1-3 (First 47 Min), Miles to Go and Needle Deflection;
 WAL, High Alt. Star, 2/20/75, 10,000', 1359-1617 EST, 1859-2117 GMT.

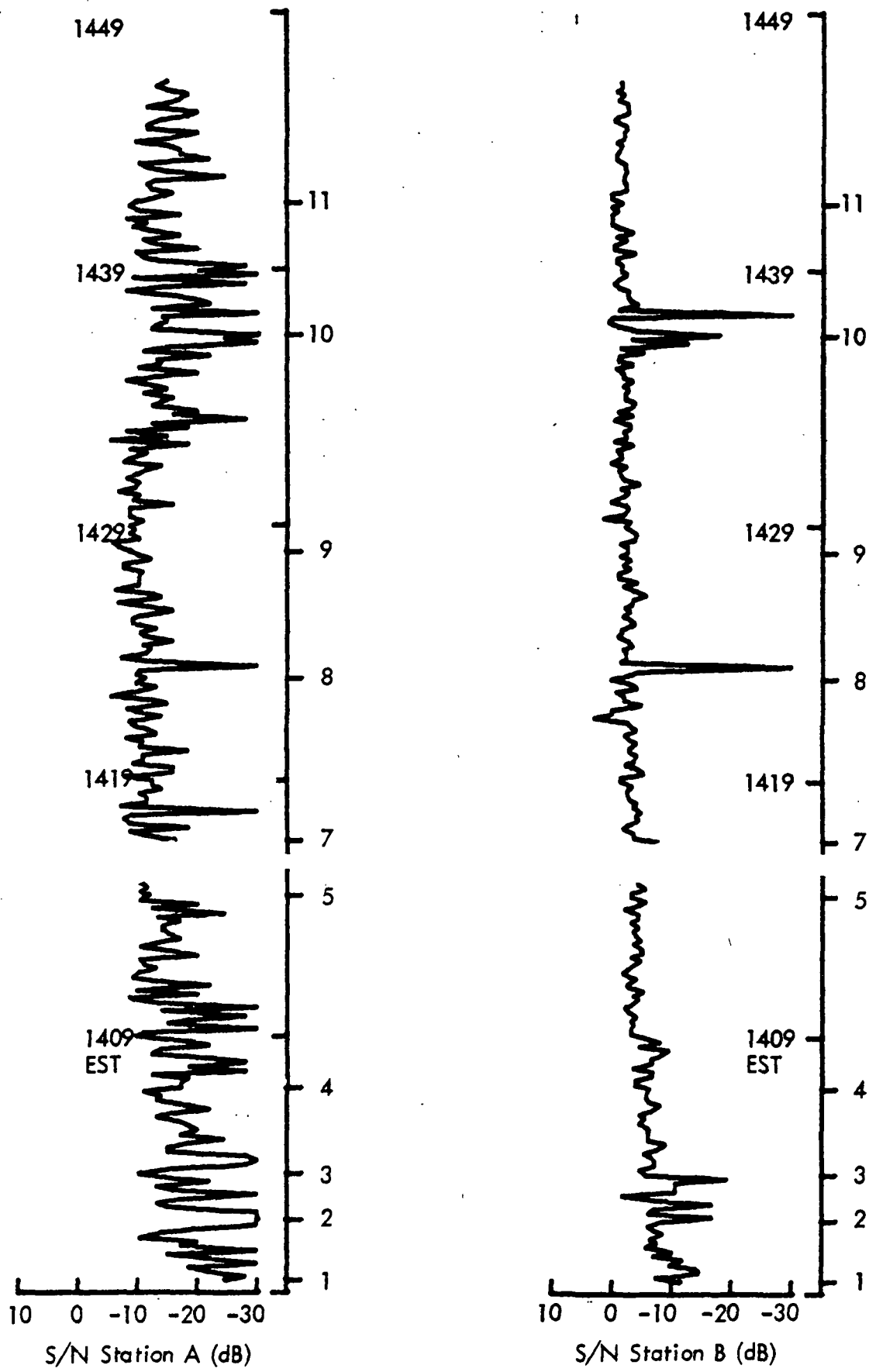

Figure A-13. Flight 1-3 (First 47 Min), S/N Station A and B;
 WAL, High Alt. Star, 2/20/75, 10,000', 1359-1617 EST, 1859-2117 GMT.

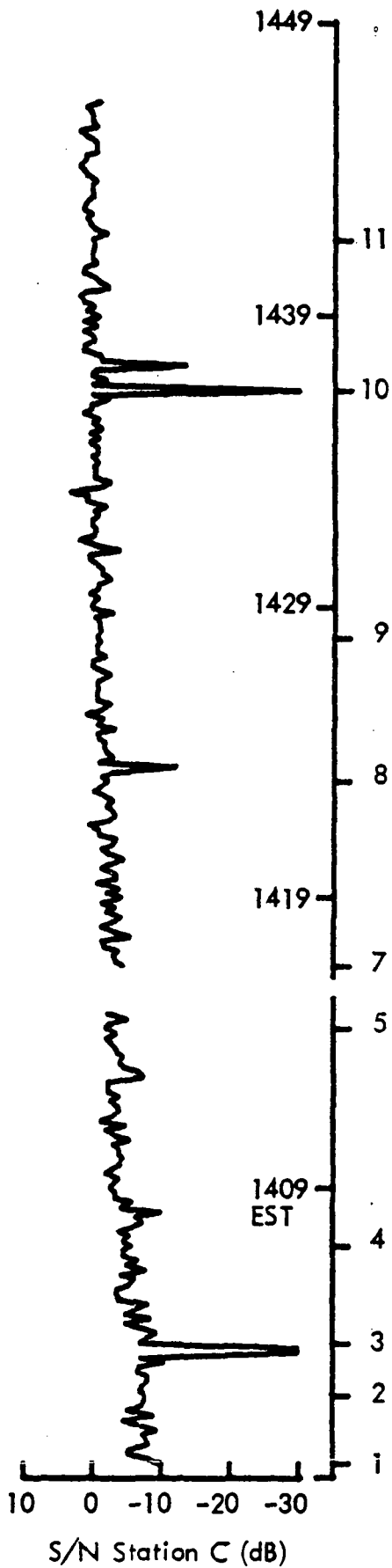

Figure A-14. Flight 1-3 (First 47 Min), S/N Station C and D;
WAL, High Alt. Star, 2/20/75, 10,000', 1359-1617 EST, 1859-2117 GMT.

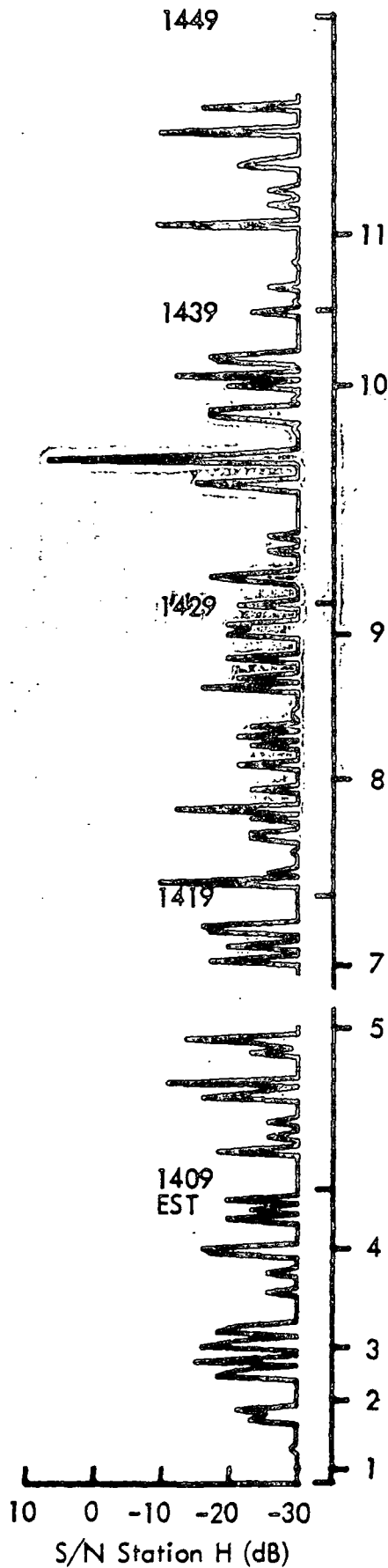

Figure A-15. Flight 1-3 (First 47 Min), S/N Station H;
 WAL, High Alt. Star, 2/20/75, 10,000', 1359-1617 EST, 1859-2117 GMT.

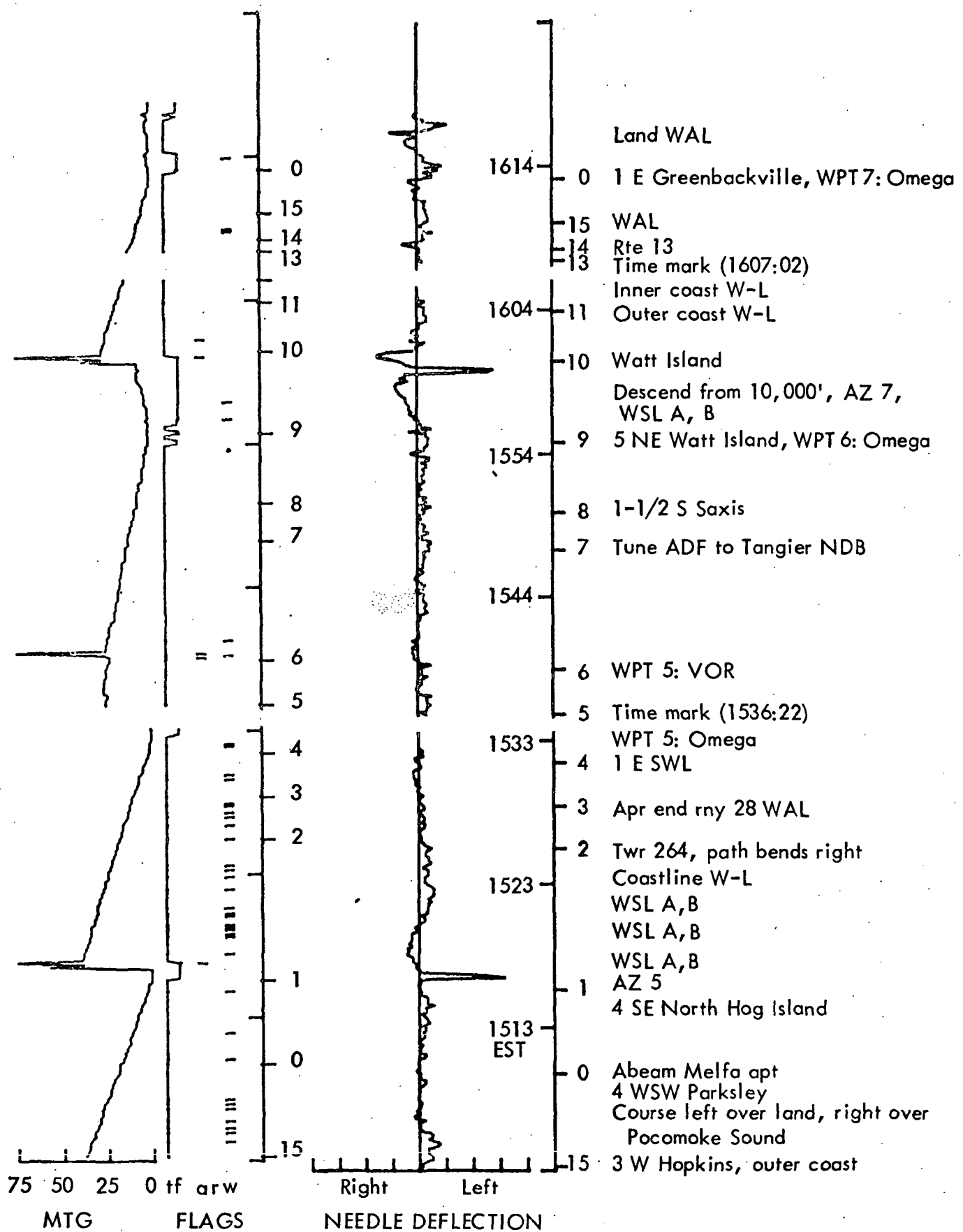

Figure A-16 . Flight 1-3 (Second 75 Min), Miles to Go and Needle Deflection;
 WAL, High Alt. Star, 2/20/75, 10,000', 1359-1617 EST, 1859-2117 GMT.

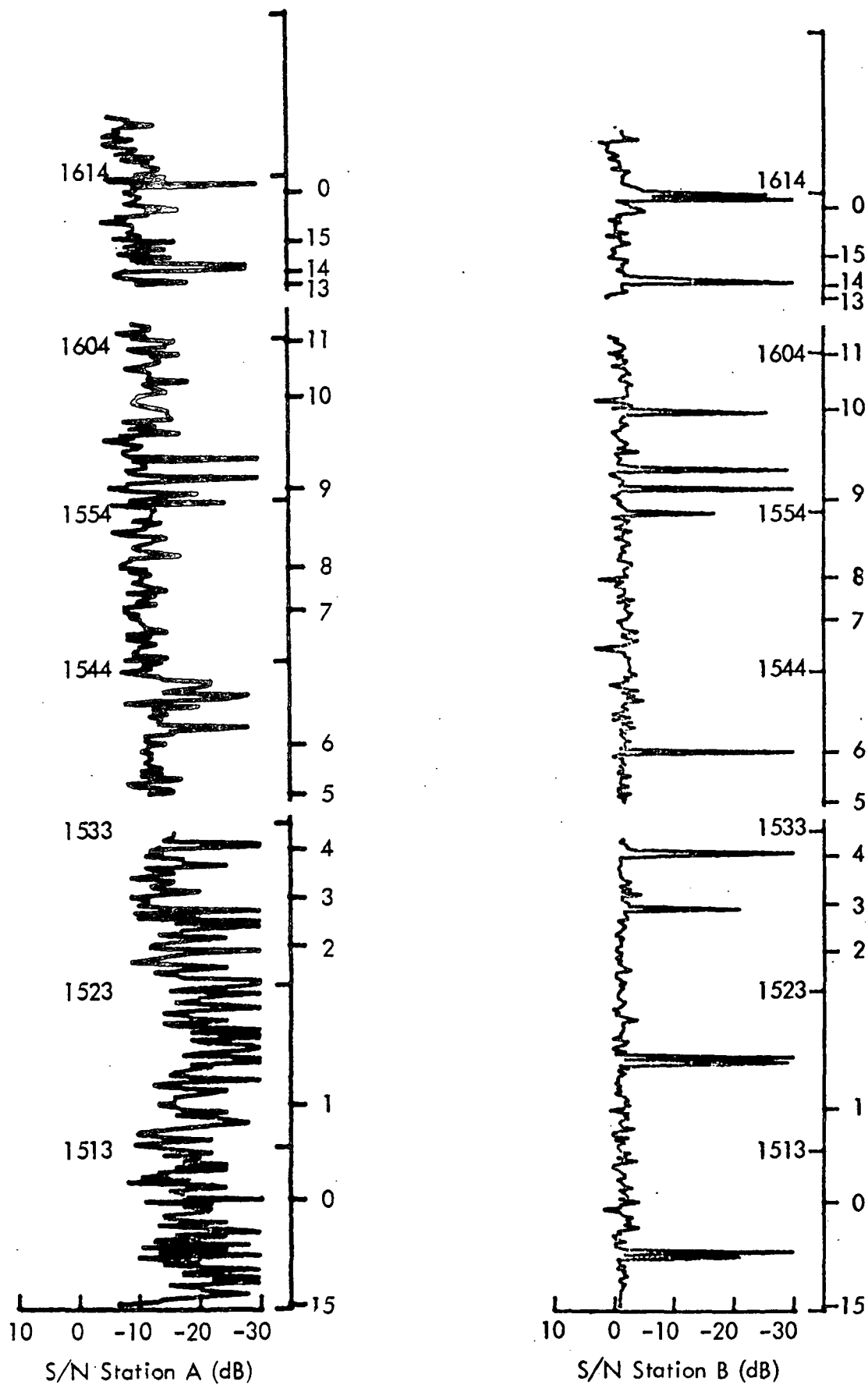

Figure A-17. Flight 1-3 (Second 75 Min), S/N Station A and B;
 WAL, High Alt. Star, 2/20/75, 10,000', 1359-1617 EST, 1859-2117 GMT.

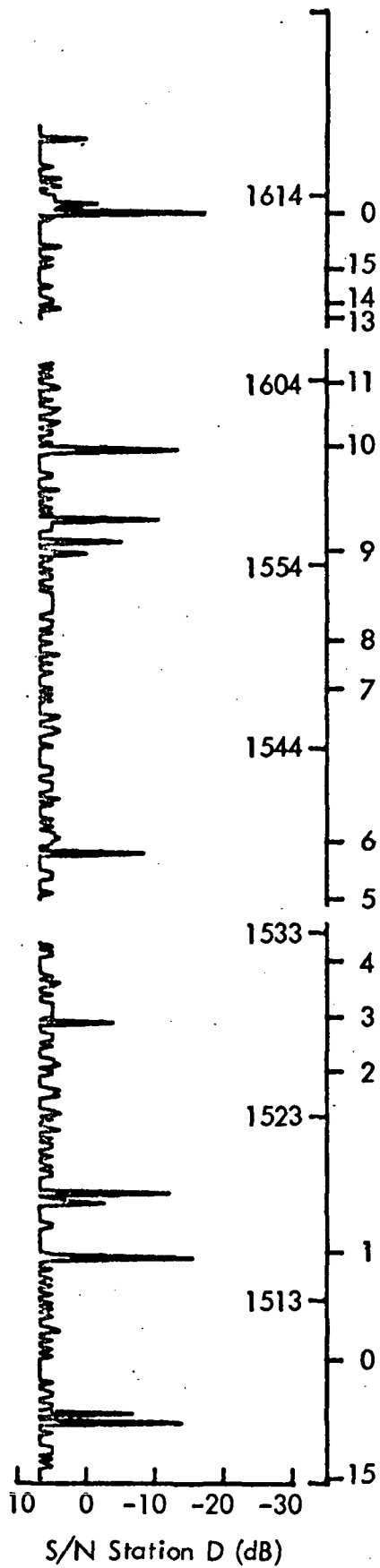
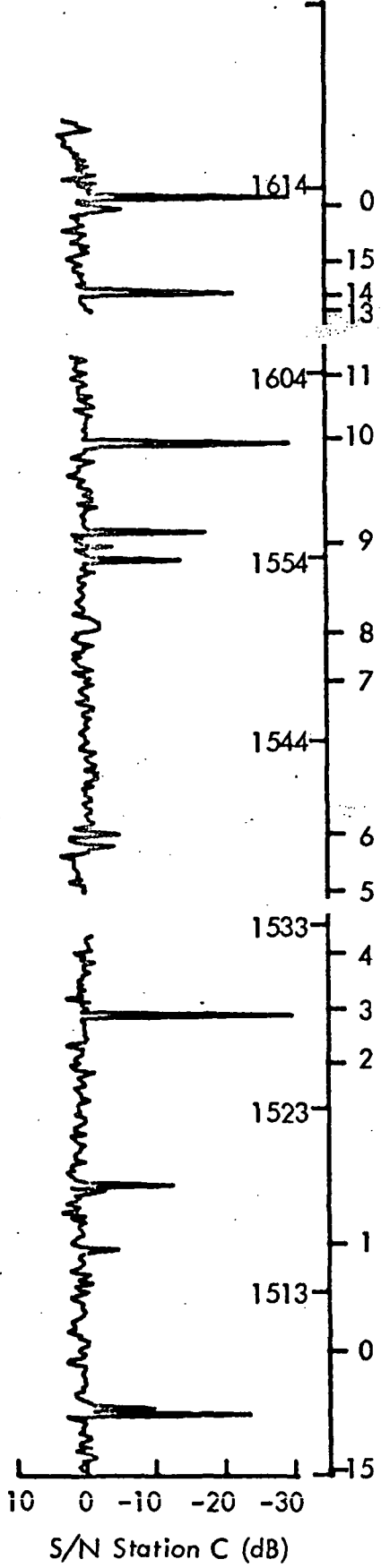

Figure A-18. Flight 1-3 (Second 75 Min), S/N Station C and D; WAL, High Alt. Star, 2/20/75, 10,000', 1359-1617 EST, 1859-2117 GMT.

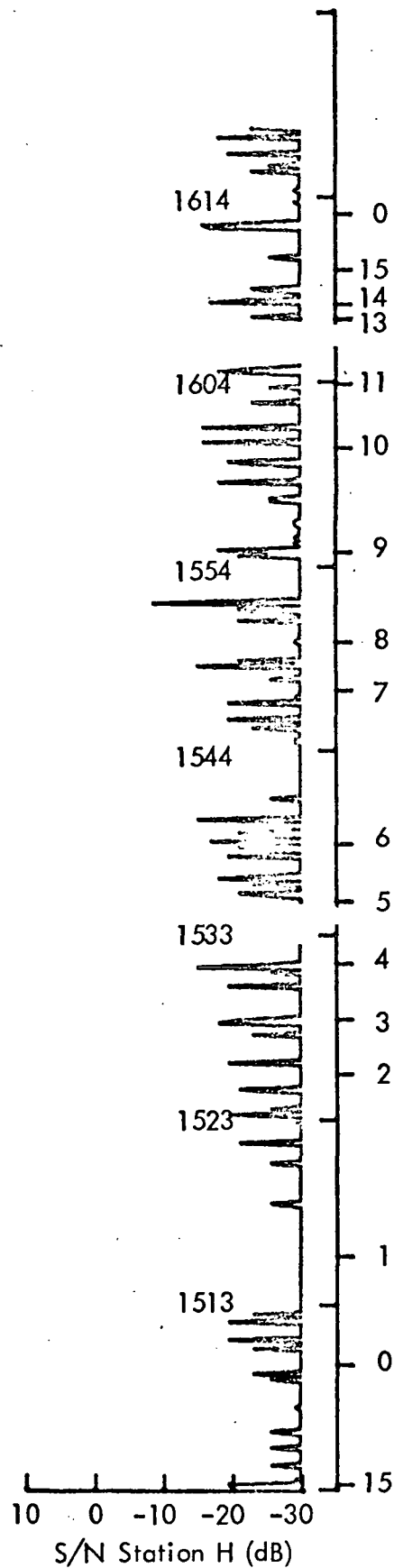

Figure A-19 . Flight 1-3 (Second 75 Min), S/N Station H;
 WAL, High Alt. Star, 2/20/75, 10,000', 1359-1617 EST, 1859-2117 GMT.

TEST DESCRIPTION

Flight No. 1-4

TEST OBJECTIVES: Check point to point accuracy with day/night effect. Obtain additional S/N ratio data for the southern Delmarva peninsula.

DATE: 2/20/75 DEPARTURE: WAL, 1710 EST

DESTINATION: ORF ROUTE: via railroad

ALTITUDE: 1500' WEATHER: VFR, 15 kts SW

SUMMARY: Incorrect waypoint set in to New Church. No interference from power lines along railroad. Incorrect waypoint for Norfolk. Sunset after landing.

KEY WORDS: Coast, diurnal, interference.

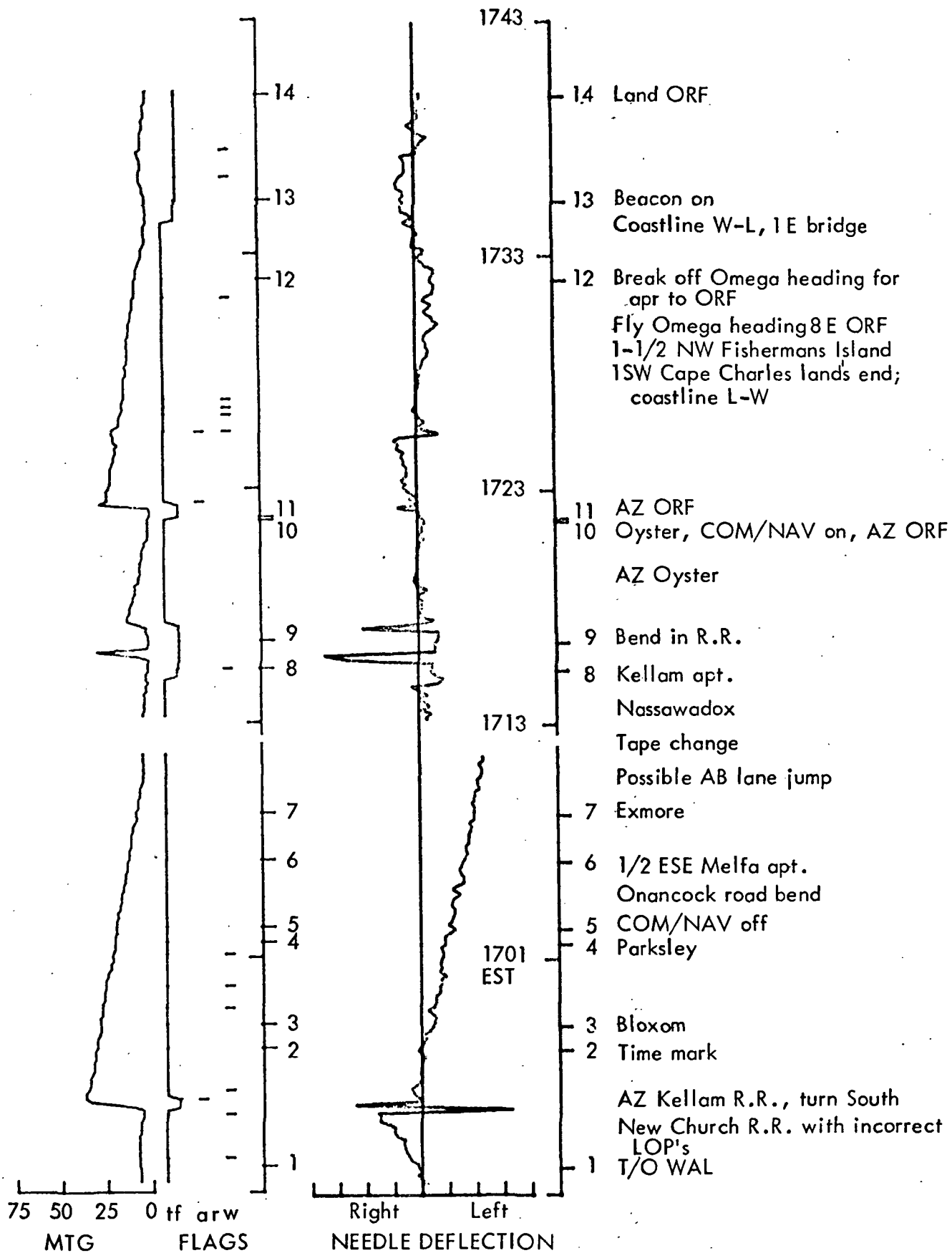

Figure A-20. Flight 1-4, Miles to Go and Needle Deflection;
WAL-ORF, 2/20/75, 1500', 1651-1740 EST, 2151-2240 GMT.

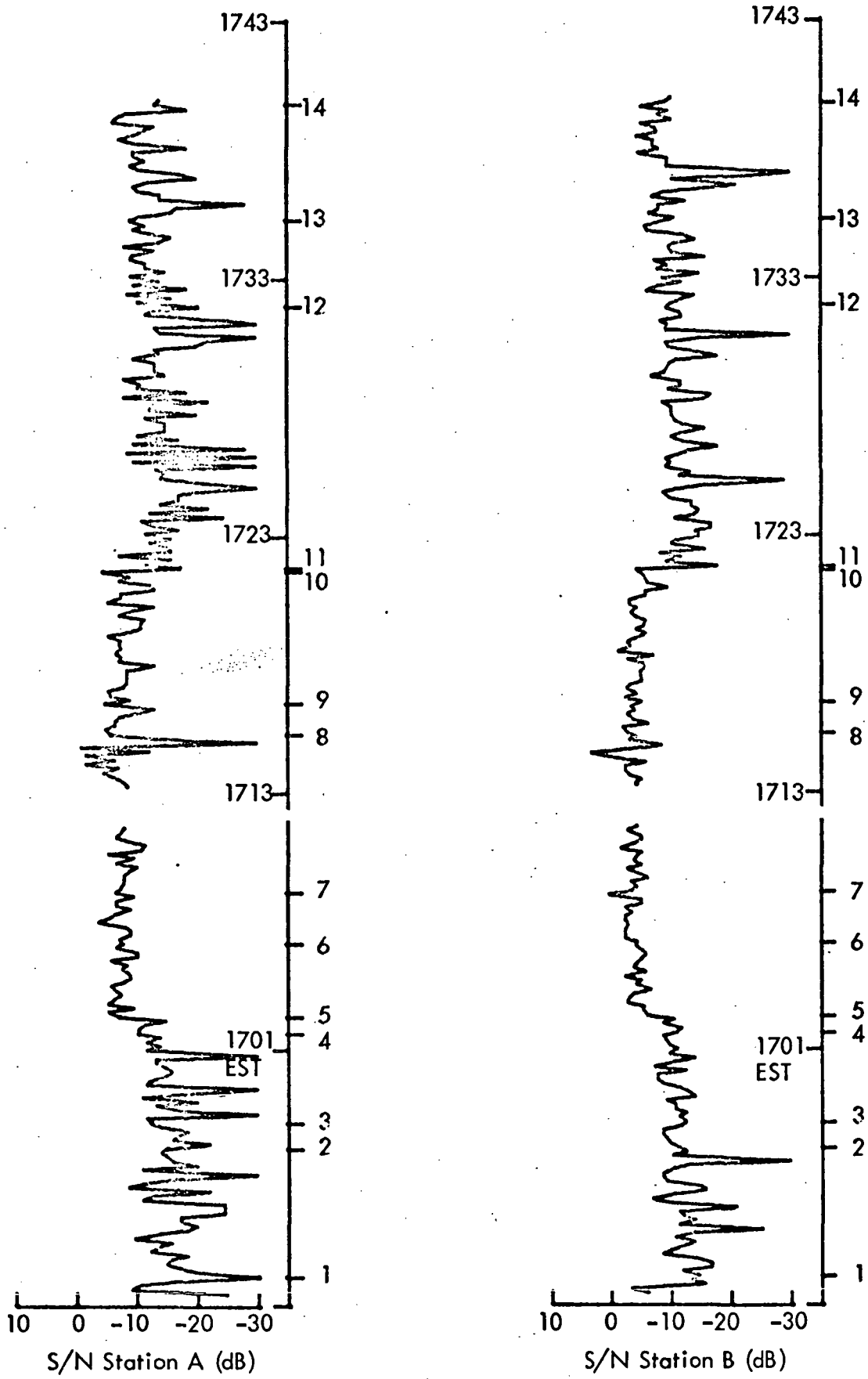

Figure A-21 . Flight 1-4, S/N Station A and B;
 WAL-ORF, 2/20/75, 1500', 1651-1740 EST, 2151-2240 GMT.

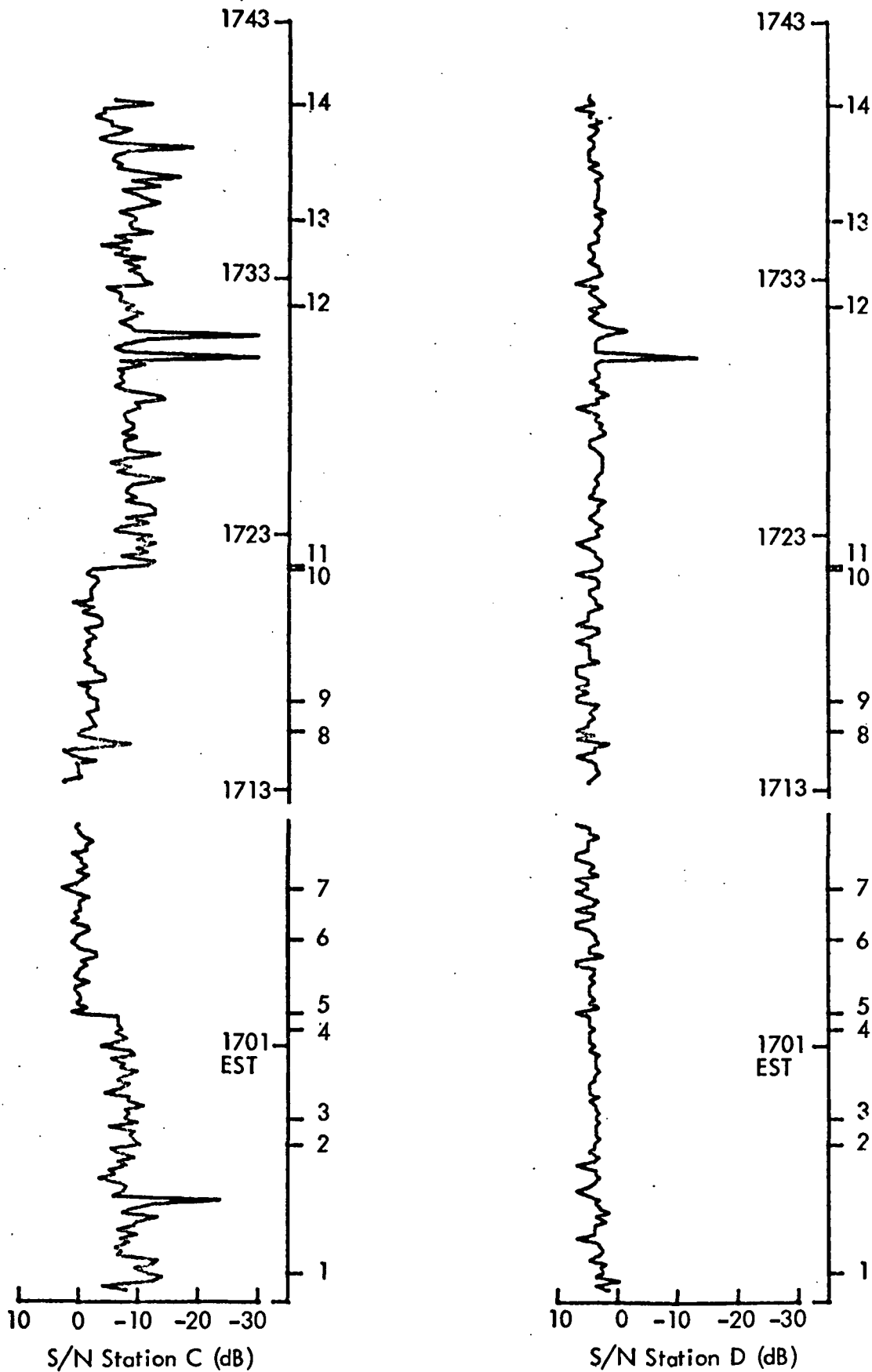

Figure A-22 . Flight 1-4, S/N Station C and D;
 WAL-ORF, 2/20/75, 1500', 1651-1740 EST, 2151-2240 GMT.

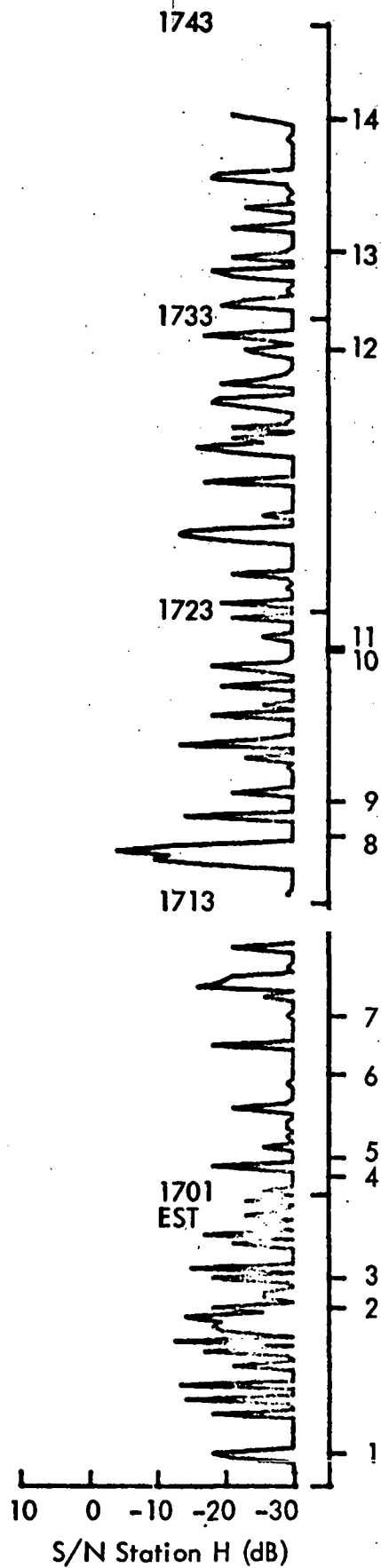

Figure A-23. Flight 1-4, S/N Station H;
 WAL-ORF, 2/20/75, 1500', 1651-1740 EST, 2151-2240 GMT.

TEST DESCRIPTION

Flight No. 1-5

TEST OBJECTIVES: Obtain S/N data along point to point routes at night, and attempt to detect coast effects.

DATE: 2/20/75

DEPARTURE: ORF, 1815 EST

DESTINATION: WAL

ROUTE: MFV, TGI, SBY, WAL

ALTITUDE: 3000'

WEATHER: Night VFR

SUMMARY: Used radio and visual beacons for a check of night accuracy of Omega.

KEY WORDS: Coast, diurnal, interference,

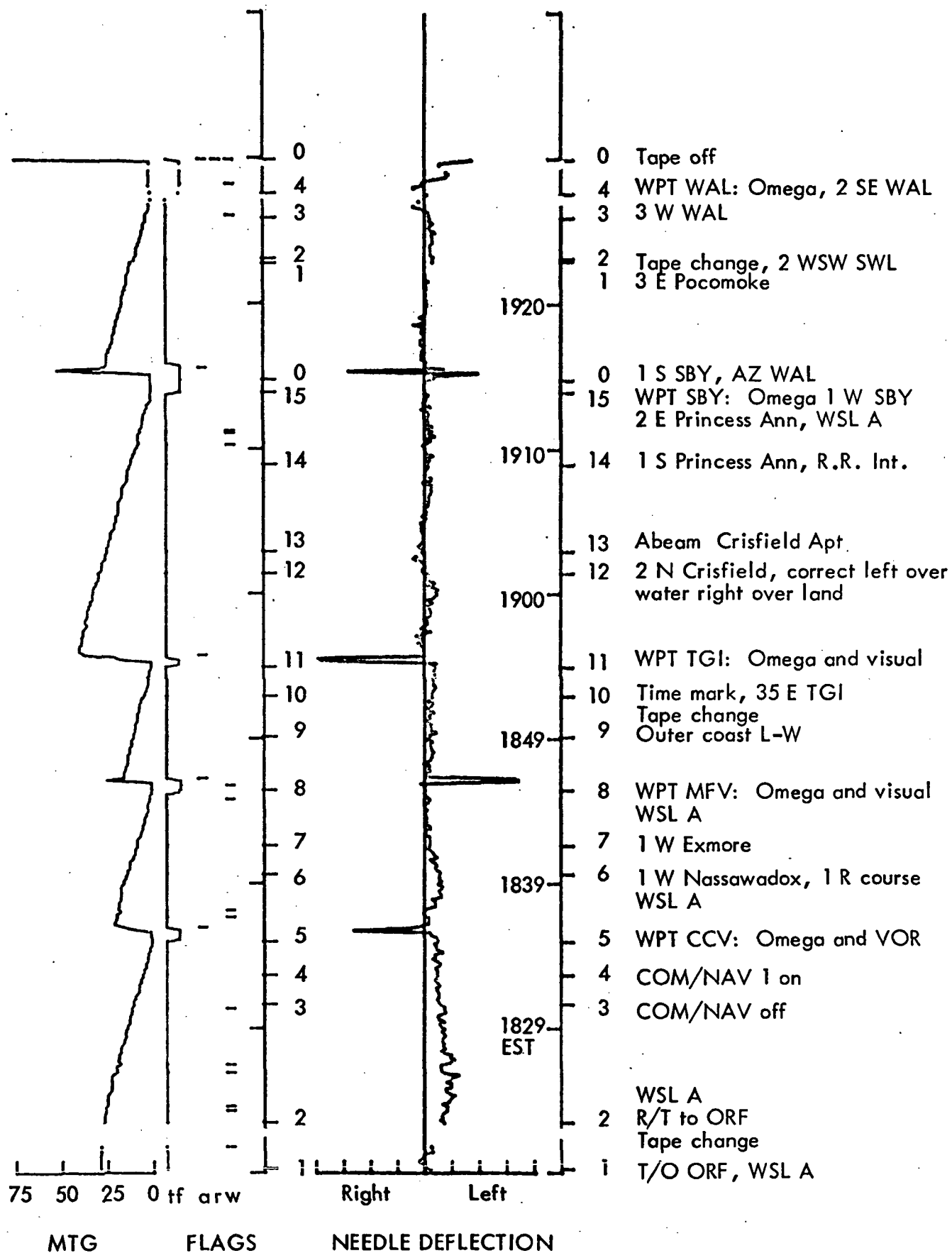

Figure A-24 . Flight 1-5, Miles to Go and Needle Deflection;
 ORF-WAL (night), 2/20/75, 3000', 1818-1932 EST, 2319-0032 GMT.

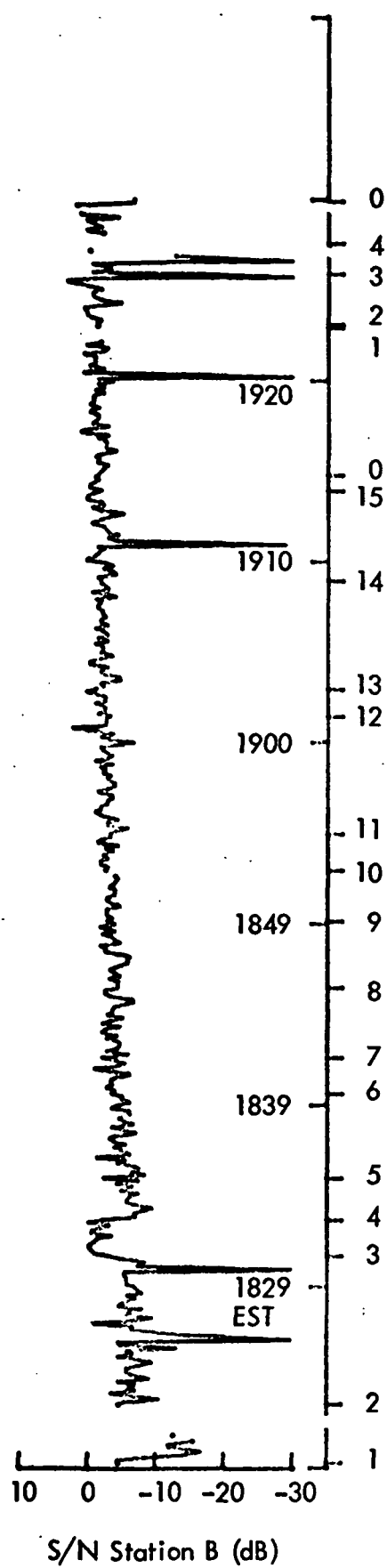
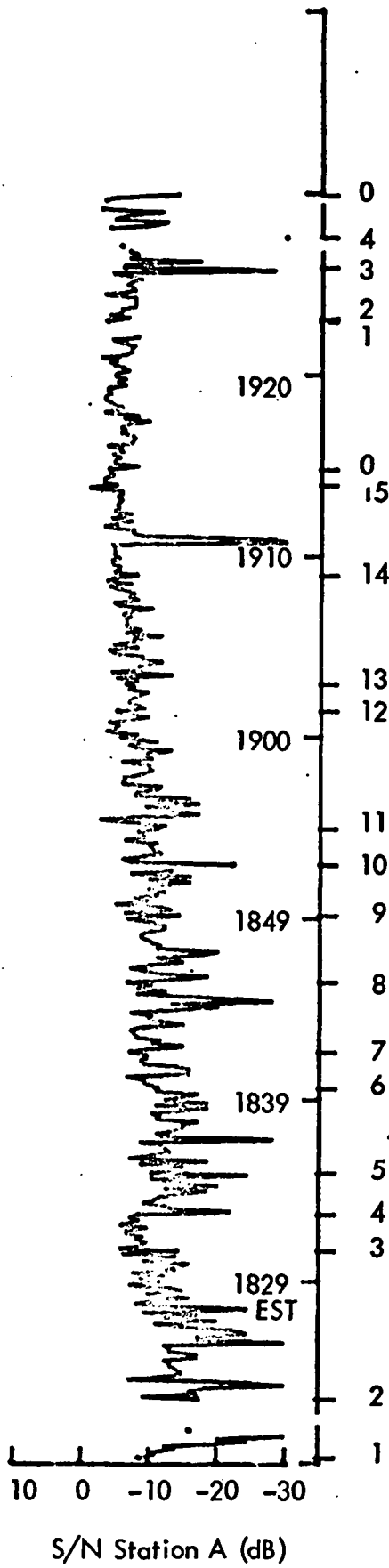

Figure A-25. Flight 1-5, S/N Station A and B;
 ORF-WAL (night), 2/20/75, 3000', 1818-1932 EST, 2319-0032 GMT.

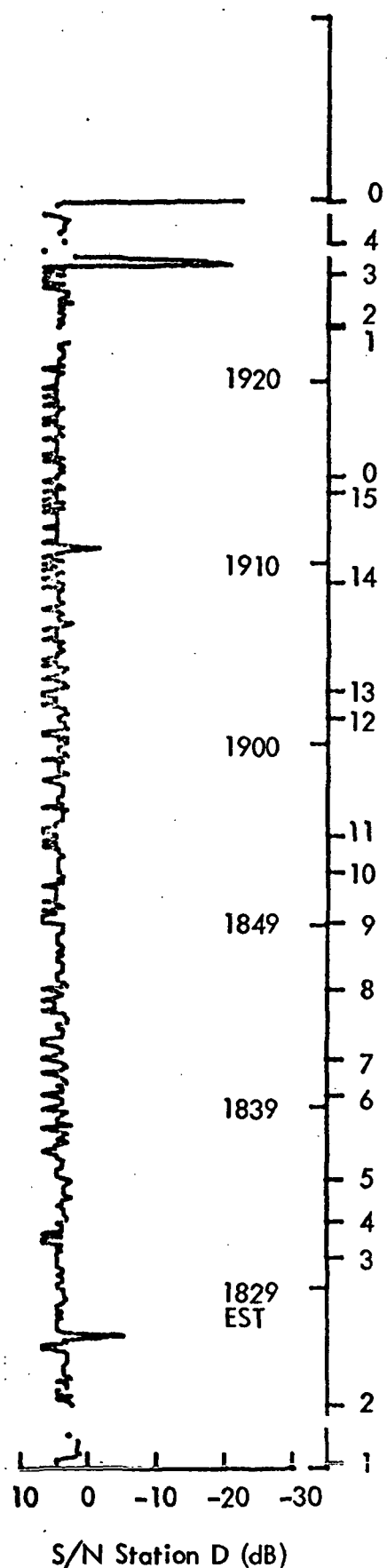
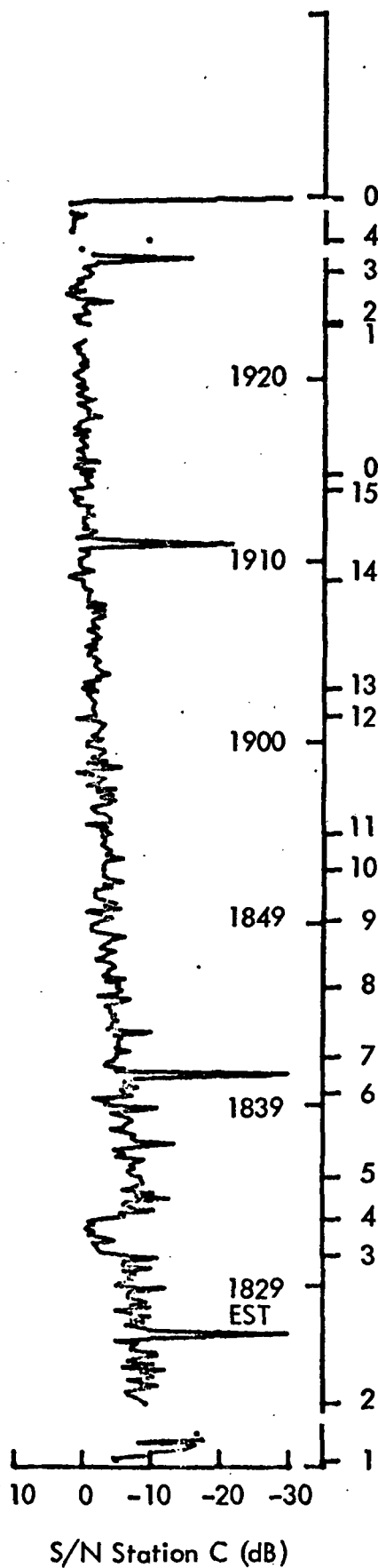
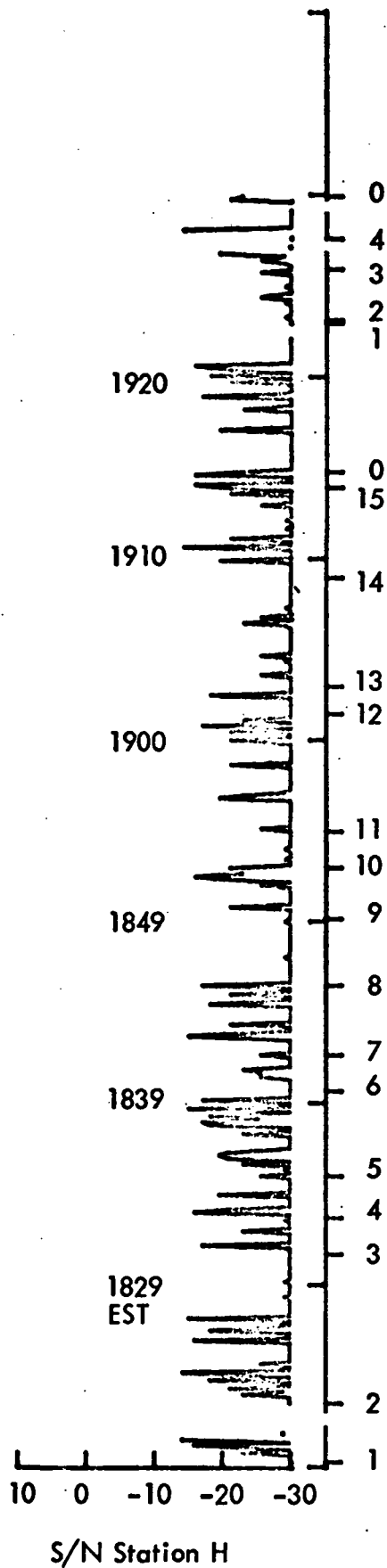

Figure A-26 . Flight 1-5, S/N Station C and D
 ORF-WAL (night), 2/20/75, 3000', 1818-1932 EST, 2319-0032 GMT.



S/N Station H

Figure A-27 . Flight 1-5, S/N Station H;
 ORF-WAL (night), 2/20/75, 3000', 1818-1932 EST, 2319-0032 GMT.

A - 36

TEST DESCRIPTION

Flight No. 1-6

TEST OBJECTIVES: Provide initial mapping of S/N in Wallops area at low altitude by flying constant A-B lanes from 20 miles south of Wallops to 20 miles north.

DATE: 2/21/75

DEPARTURE: WAL, 1030 EST

DESTINATION: SBY

ROUTE: Modified snake route

ALTITUDE: 2000'

WEATHER: VFR, 15 kts, SW

SUMMARY: Flight was modified enroute due to difficulty of obtaining station A signal. Lane count was lost 4 times.

KEY WORDS: Coast, LOP direction, interference.

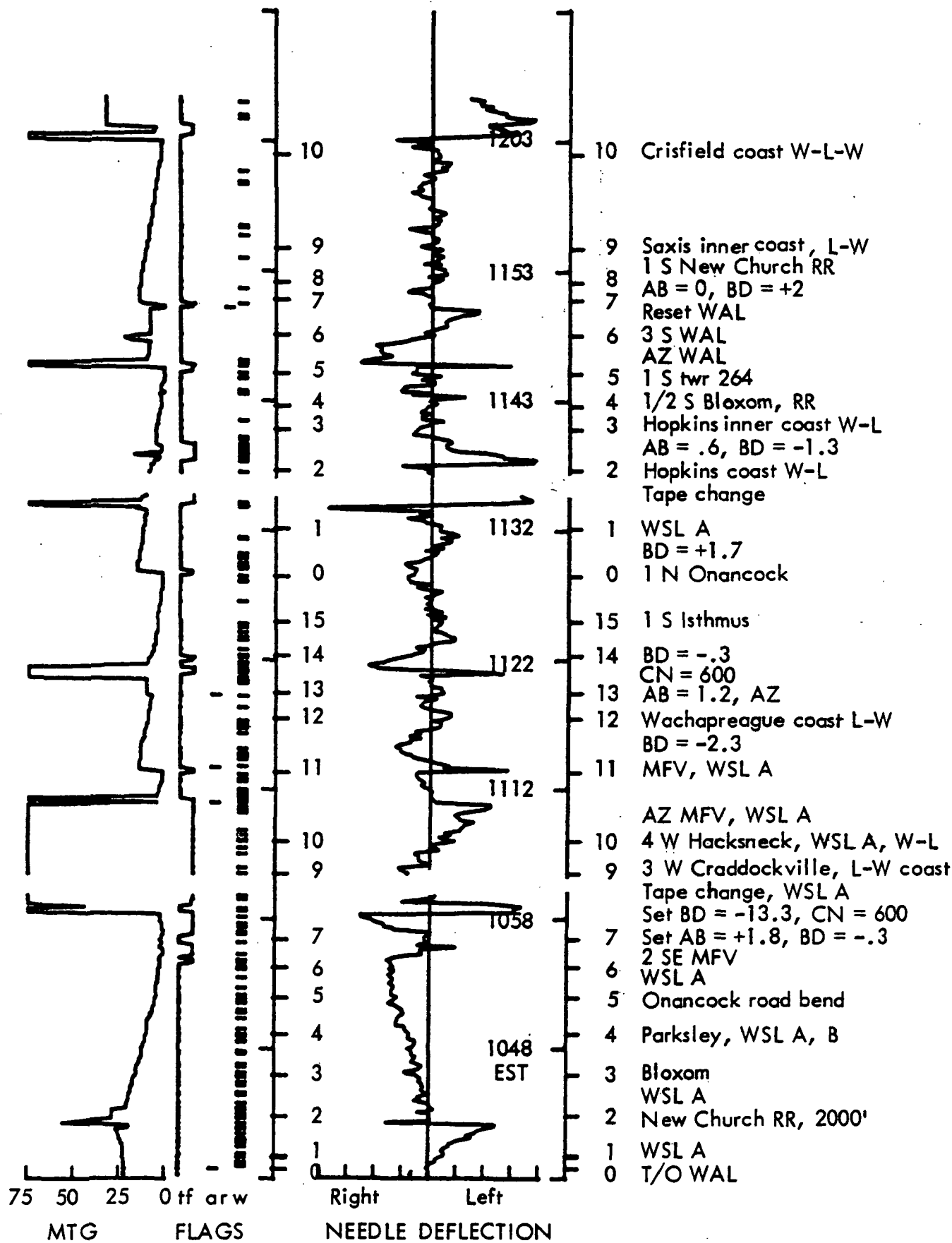
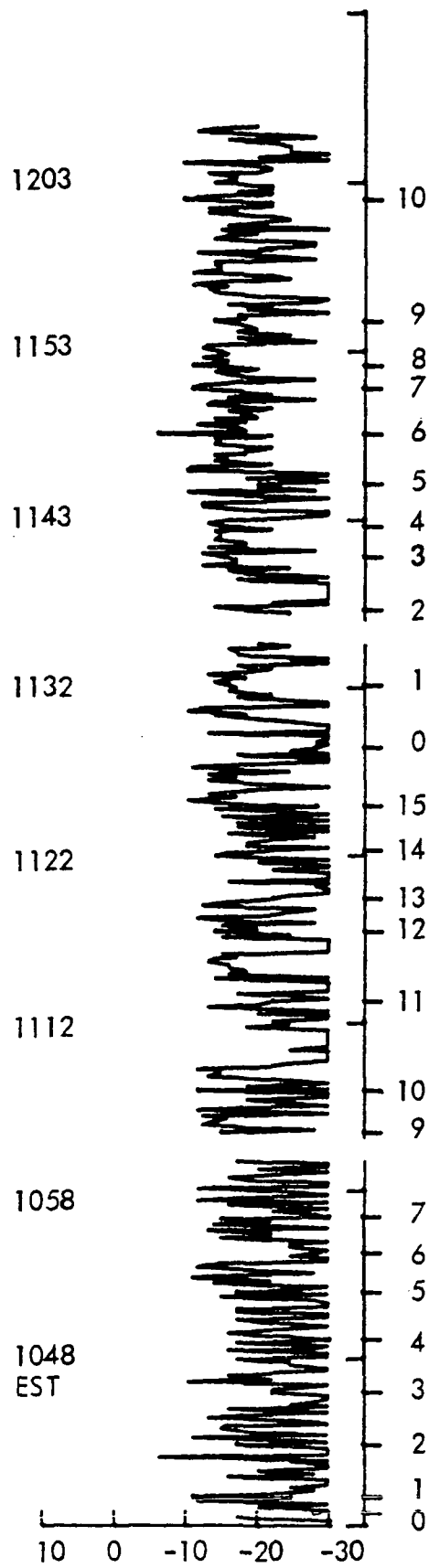
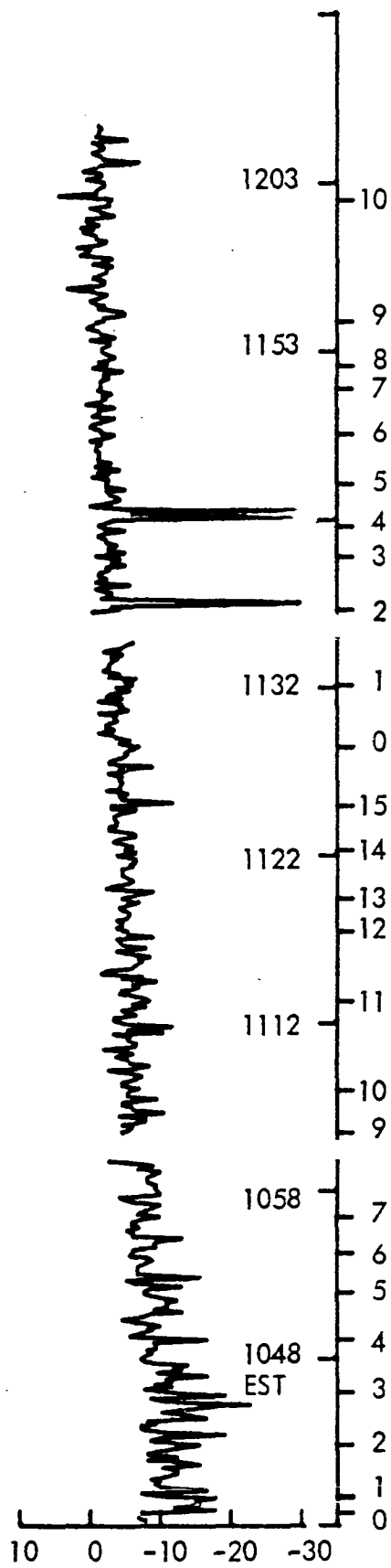

Figure A-28. Flight 1-6 (First 89 min.), Miles to Go and Needle Deflection;
WAL-SBY snake, 2/21/75, 2000', 1038-1320 EST, 1538-1820 GMT.



S/N Station A (dB)



S/N Station B (dB)

Figure A-29. Flight 1-6 (First 89 min.), S/N Station A and B;
 WAL-SBY snake, 2/21/75, 2000', 1038-1320 EST, 1538-1820 GMT.

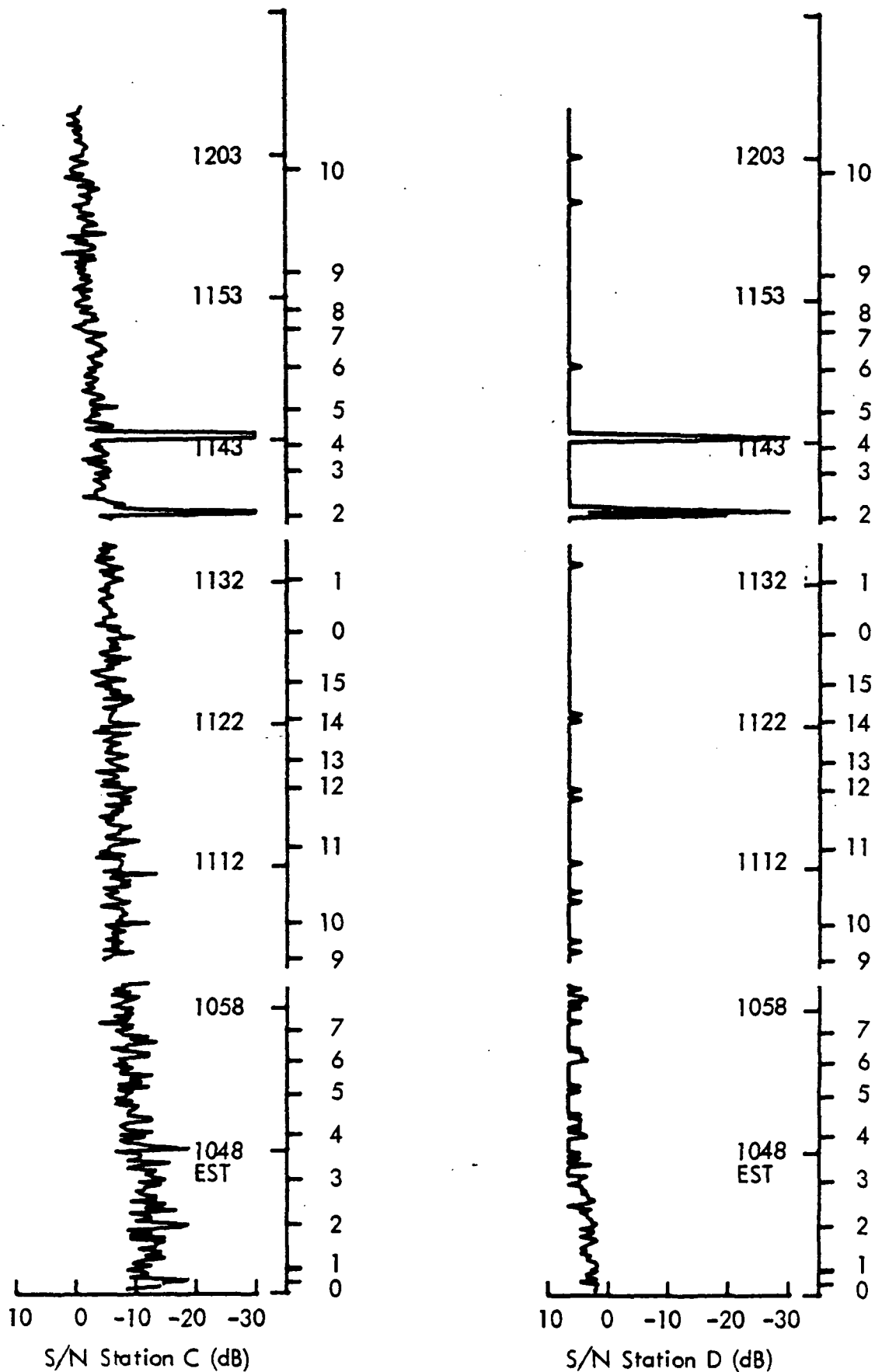

Figure A-30. Flight 1-6 (First 89 min.), S/N Station C and D; WAL-SBY snake, 2/21/75, 2000', 1038-1320 EST, 1538-1820 GMT.

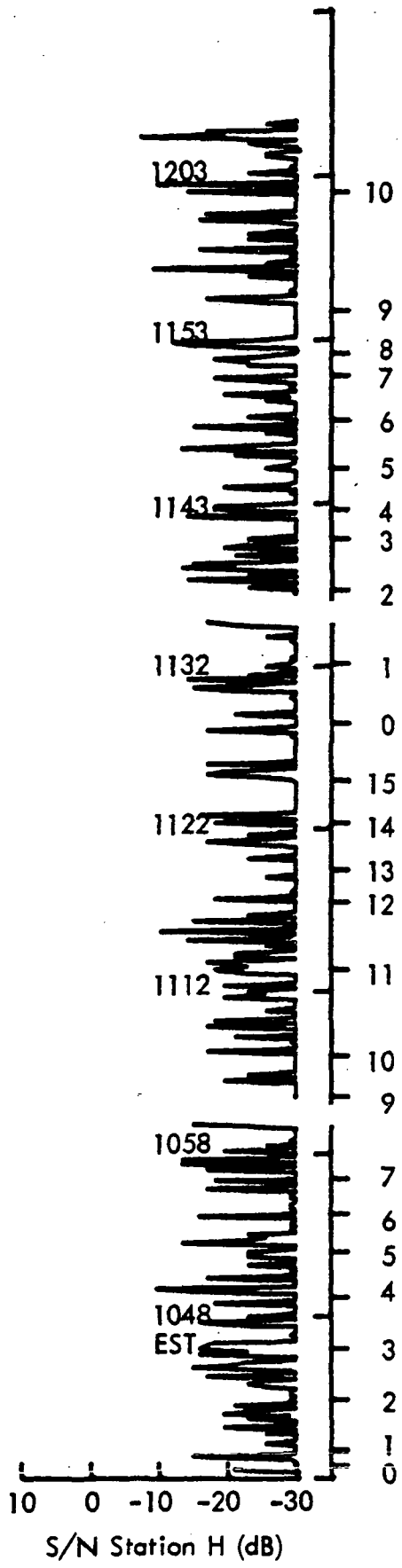

Figure A-31 . Flight I-6 (First 89 min.), S/N Station H;
 WAL-SBY snake, 2/21/75, 2000', 1038-1320 EST, 1538-1820 GMT.

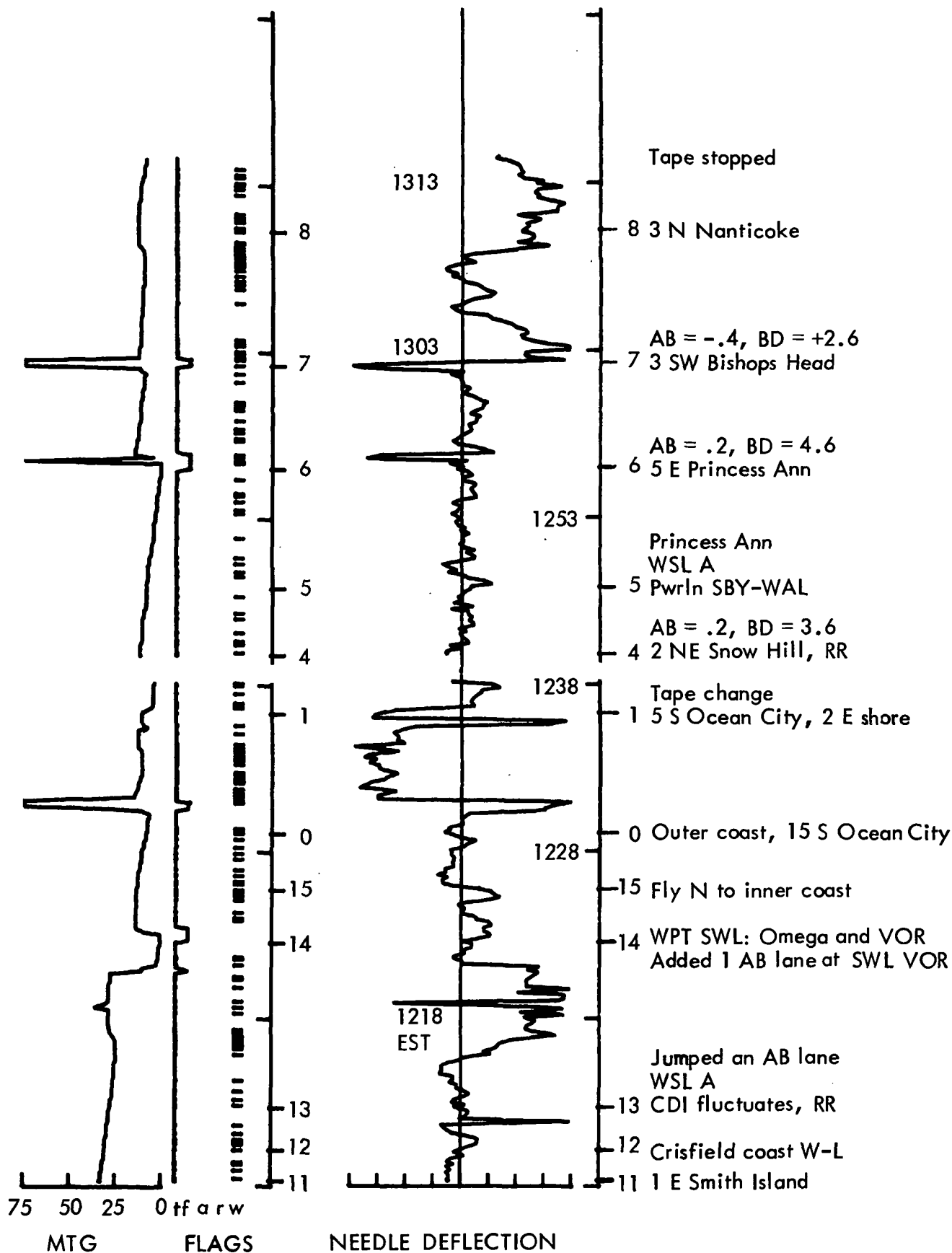

Figure A-32: Flight 1-6 (Second 66 min.), Miles to Go and Needle Deflection;
WAL-SBY snake, 2/21/75, 2000', 1038-1320 EST, 1538-1820 GMT.

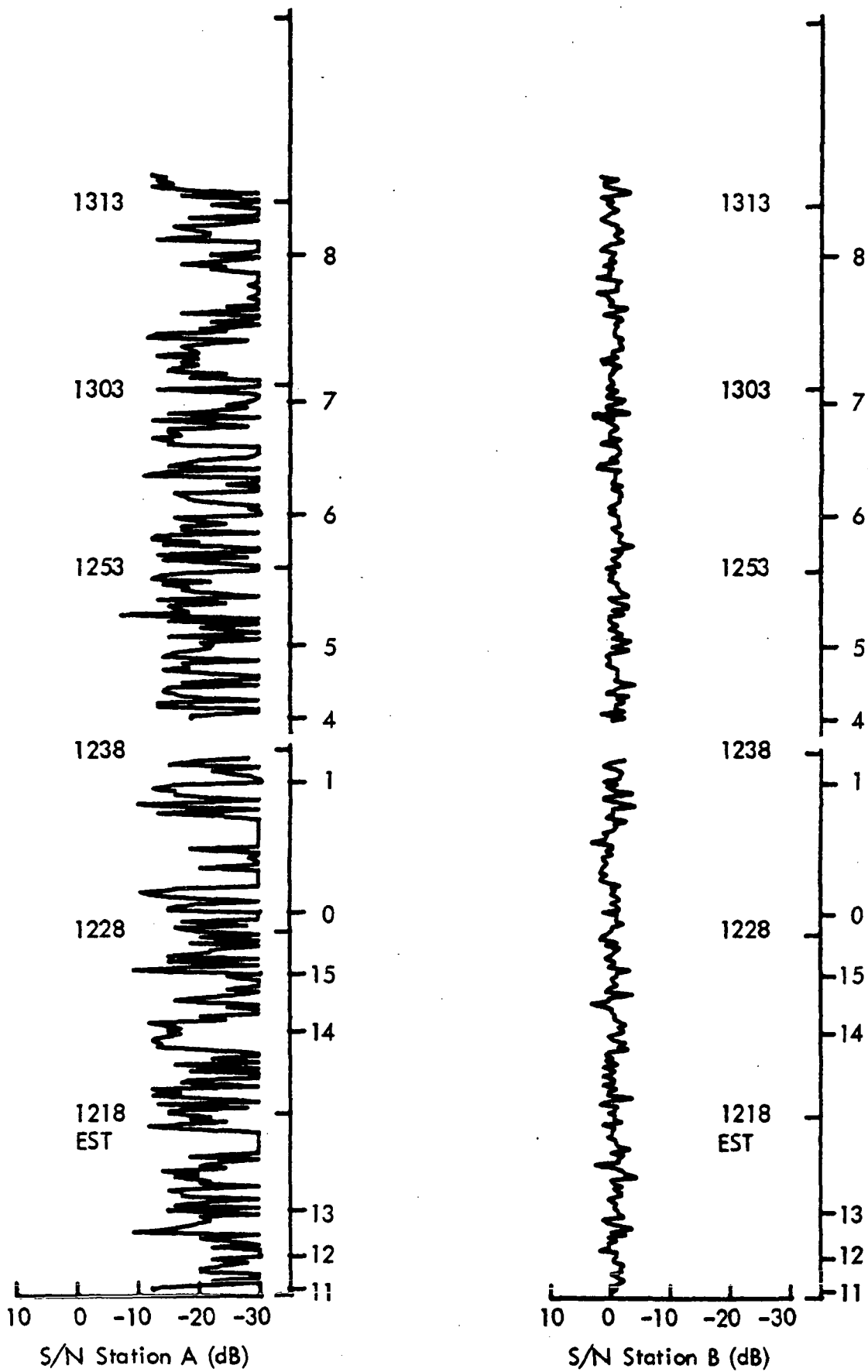

Figure A-33. Flight 1-6 (Second 66 min.), S/N Station A and B; WAL-SBY snake, 2/21/75, 2000', 1038-1320 EST, 1538-1820 GMT.

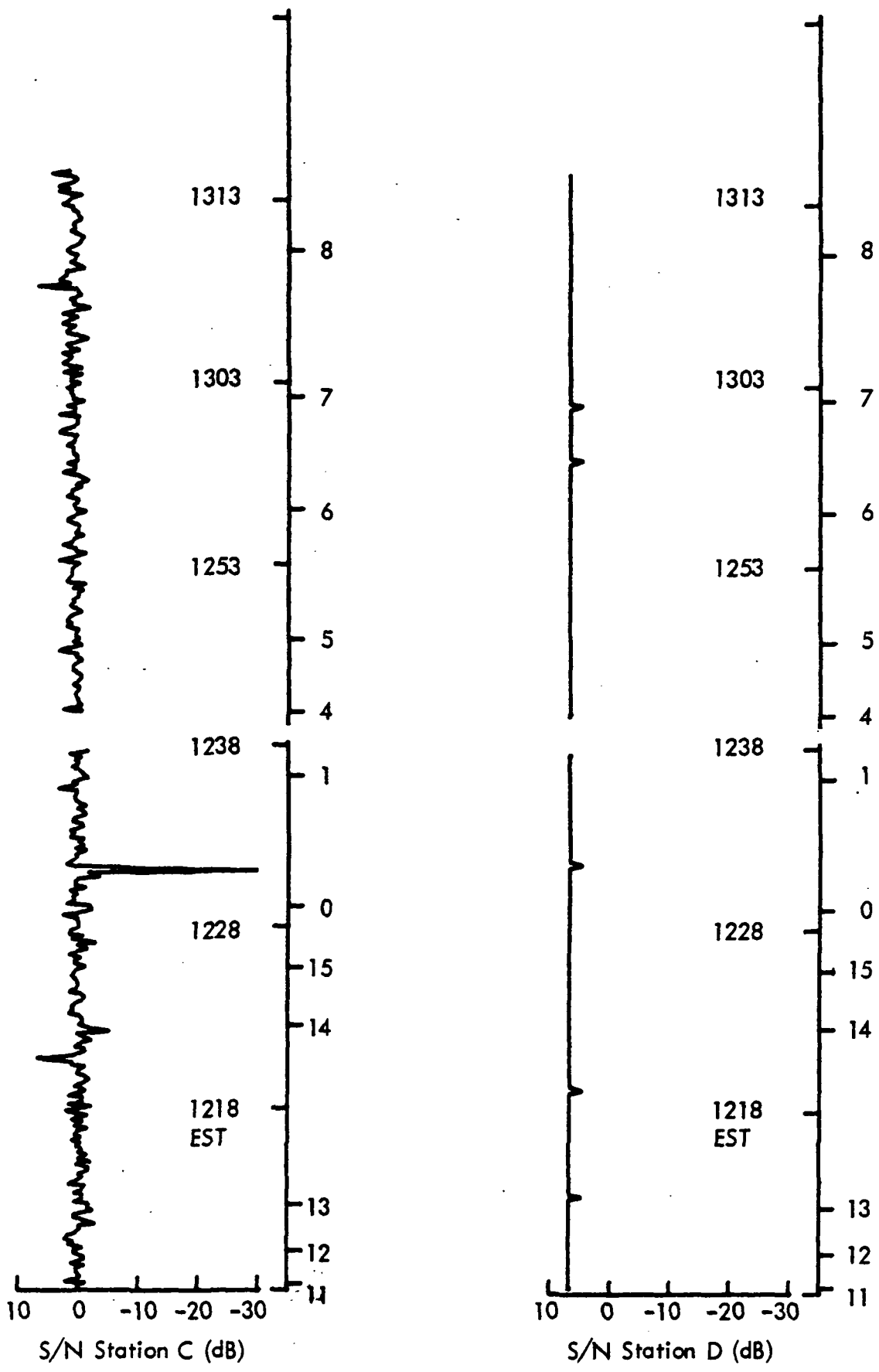

Figure A-34. Flight 1-6 (Second 66 min.), S/N Station C and D; WAL-SBY snake, 2/21/75, 2000', 1038-1320 EST, 1538-1820 GMT.

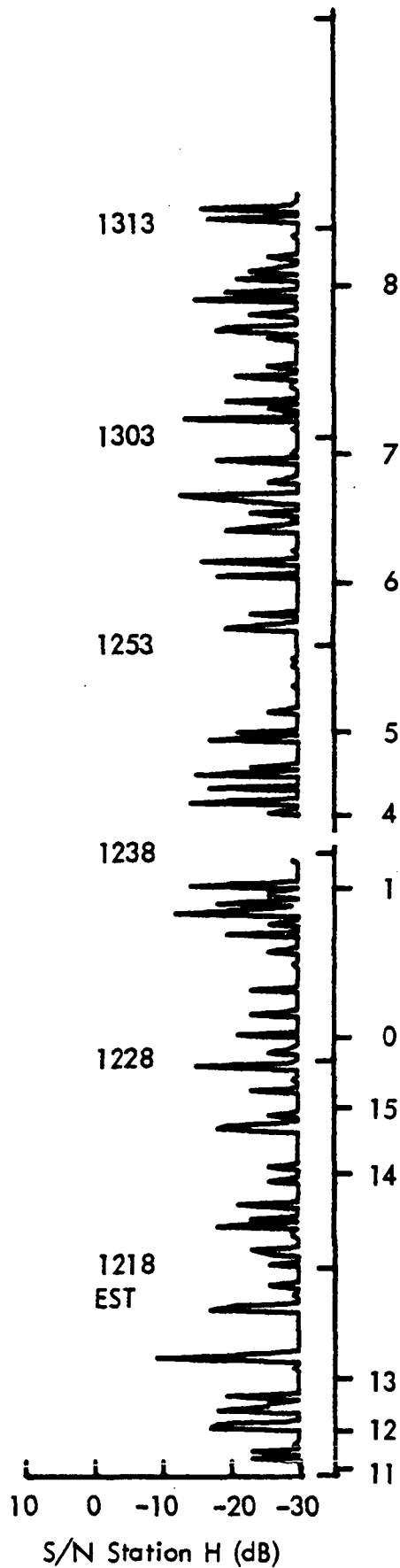

Figure A-35. Flight 1-6 (Second 66 min.), S/N Station H; WAL-SBY snake, 2/21/75, 2000', 1038-1320 EST, 1538-1820 GMT.

TEST DESCRIPTION

Flight No. 1-7

TEST OBJECTIVES: Point to point accuracy check through Snow Hill VOR area.

DATE: 2/21/75

DEPARTURE: SBY, 1430 EST

DESTINATION: WAL

ROUTE: via SWL

ALTITUDE: 1500'

WEATHER: VFR, 15 kts SW

SUMMARY: First two thirds of recorded data lost due to improper jack input.

KEY WORDS: Interference.

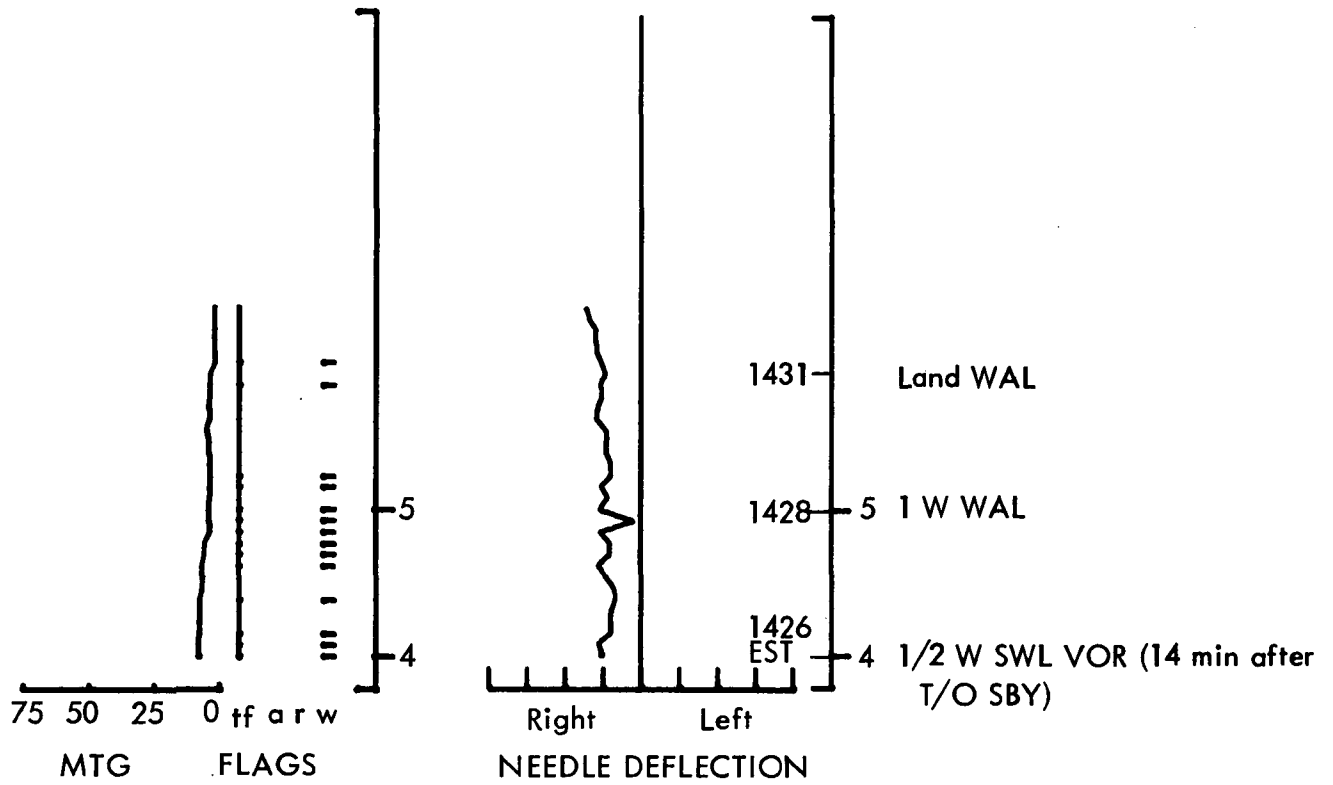

Figure A-36. Flight 1-7 (Last 6 Min), Miles to Go and Needle Deflection; SBY-WAL, 2/21/75, 2000', 1412-1432 EST, 1912-1932 GMT.

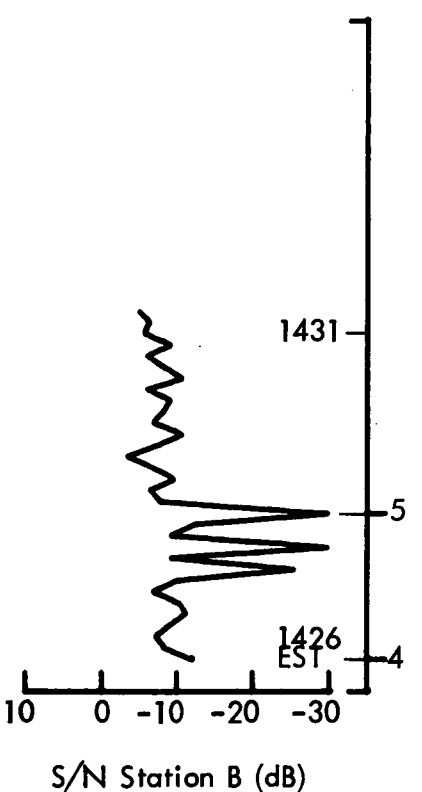
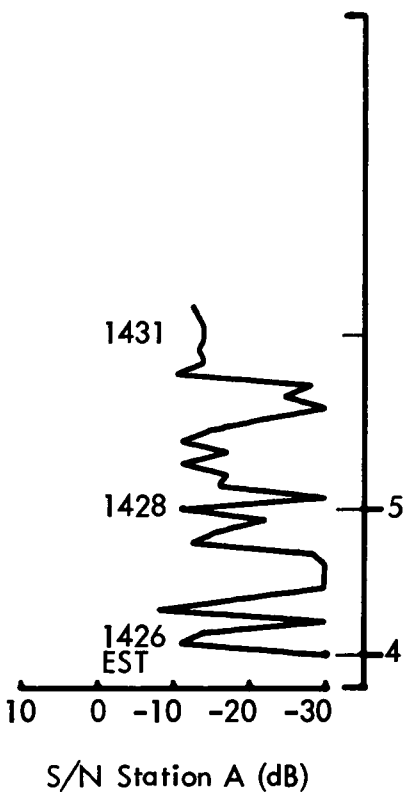
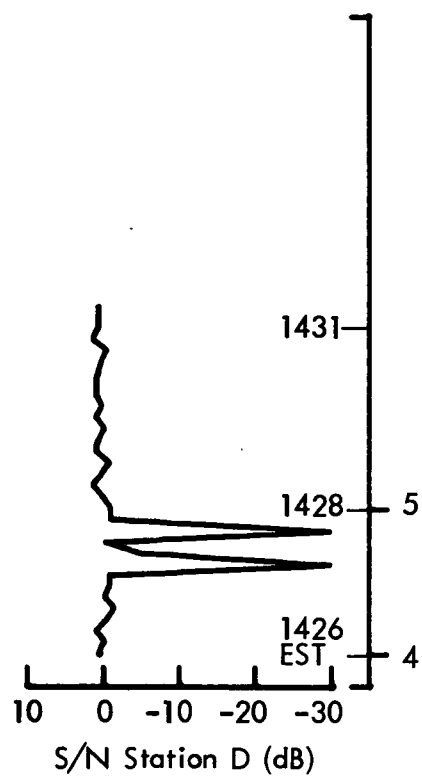
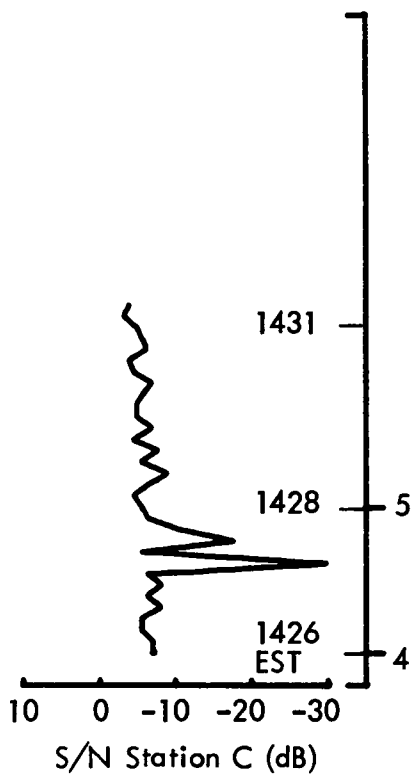

Figure A-37. Flight 1-7 (Last 6 Min), S/N Station A, B, C and D; SBY-WAL, 2/21/75, 2000', 1412-1432 EST, 1912-1932 GMT.

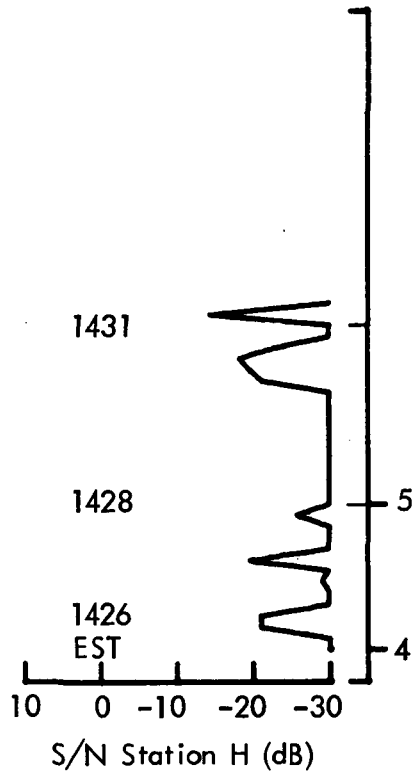

Figure A-38 . Flight 1-7 (Last 6 Min), S/N Station H;
 SBY-WAL, 2/21/75, 2000', 1412-1432 EST, 1912-1932 GMT.

TEST DESCRIPTION

Flight No. 1-8

TEST OBJECTIVES: Initial check of LOP sensitivity with radar coverage along constant A-B and B-D LOPs.

DATE: 2/21/75

DEPARTURE: WAL, 1610 EST

DESTINATION: WAL

ROUTE: Race track

ALTITUDE: 3000'

WEATHER: VFR, calm

SUMMARY: Moderate amount of difficulty following rapid CDI oscillations due to local interference (radar).

KEY WORDS: Coast, LOP direction, diurnal, interference, maneuvers, radar.

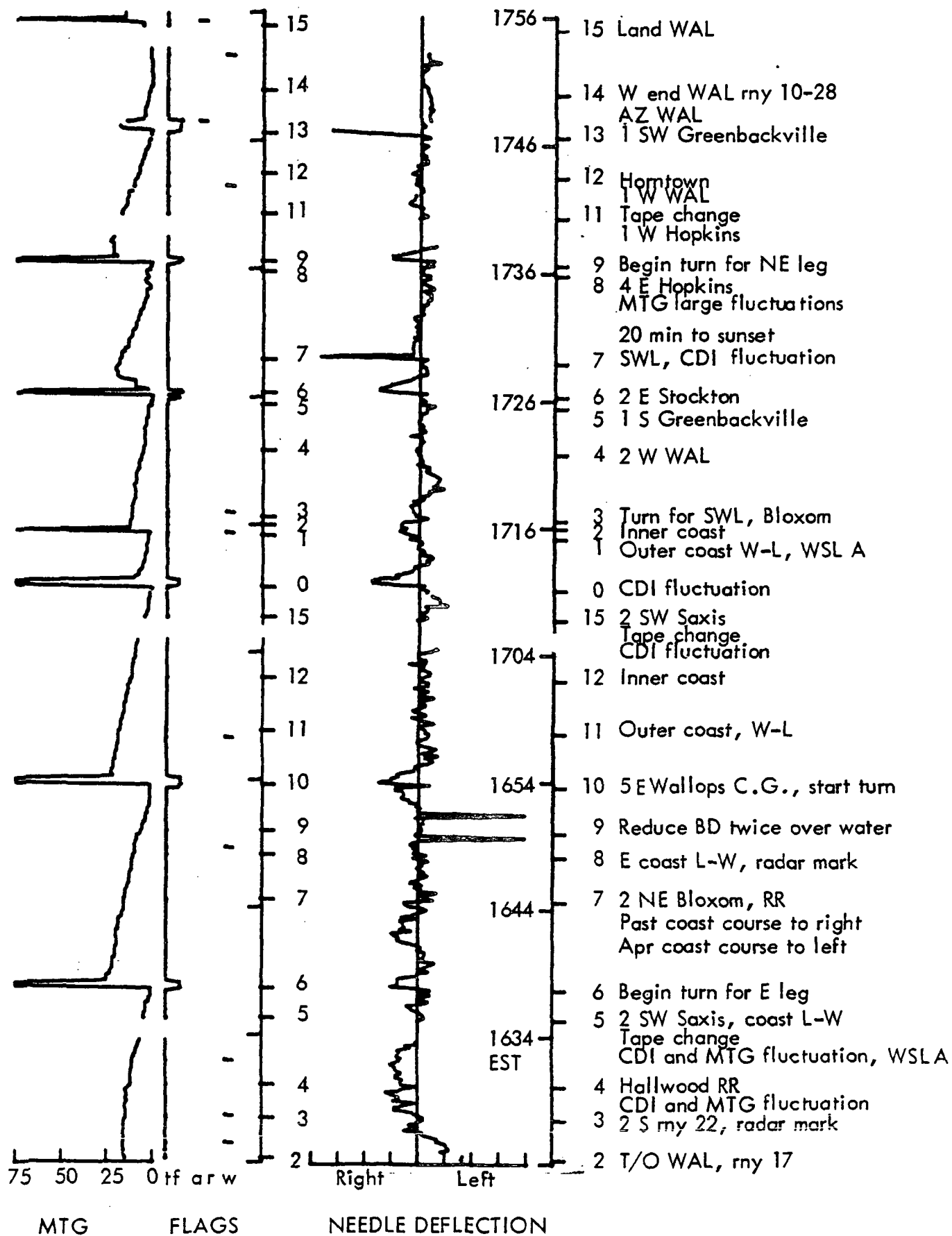

Figure A-39 . Flight 1-8, Miles to Go and Needle Deflection;
 WAL-racetrack (day, radar), 2/21/75, 3000', 1624-1750 EST, 2124-2250 GMT.

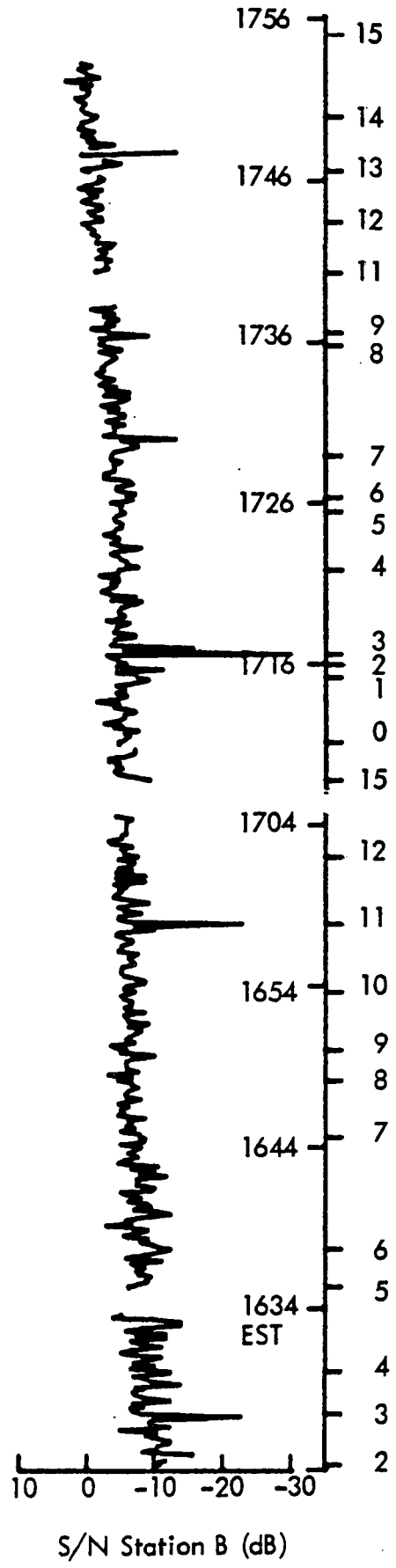
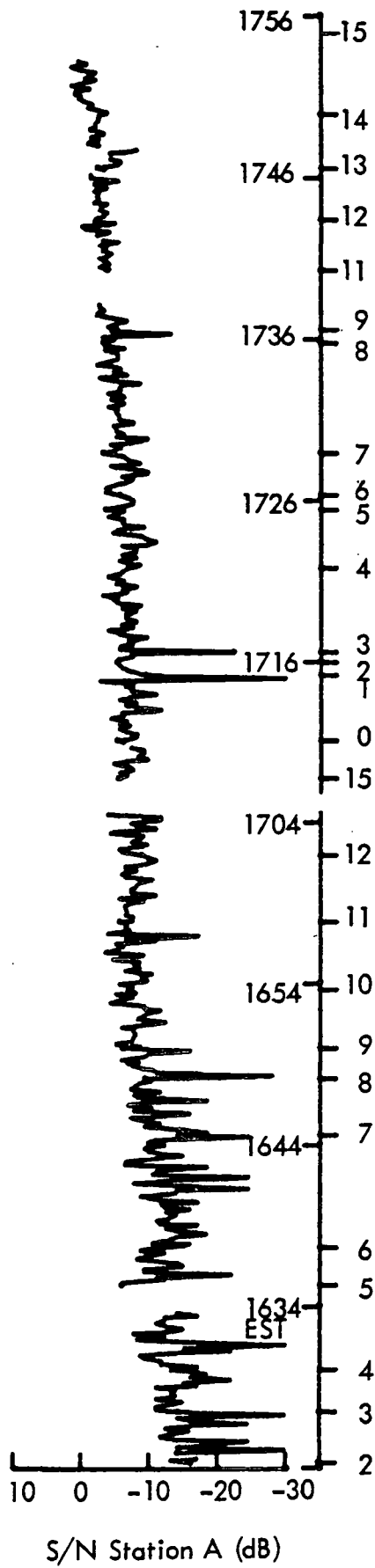

Figure A-40 . Flight 1-8, S/N Station A and B;
 WAL-racetrack (day, radar), 2/21/75, 3000', 1624-1750 EST, 2124-2250 GMT.

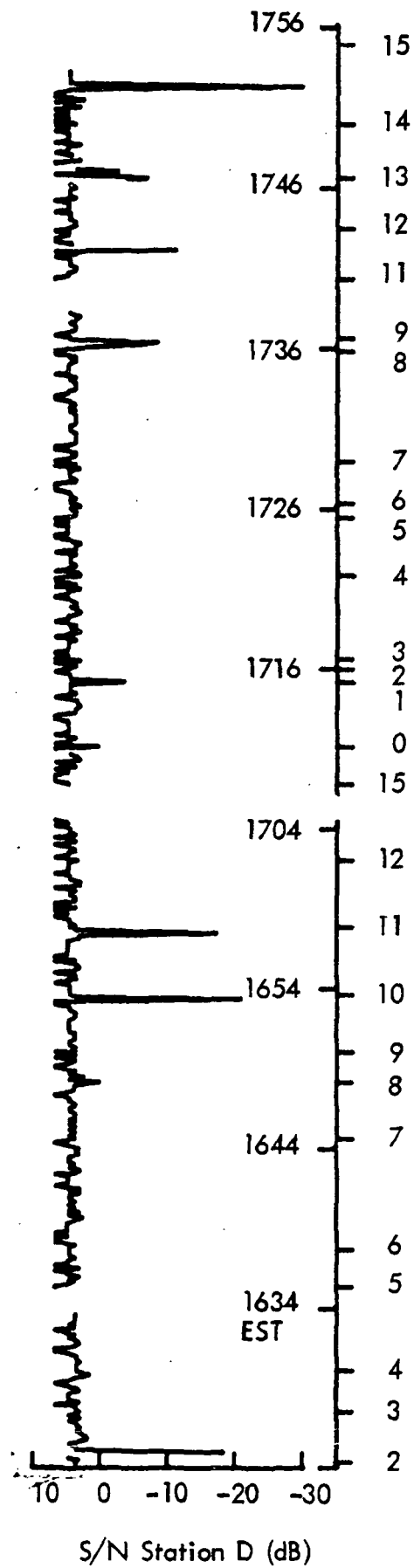
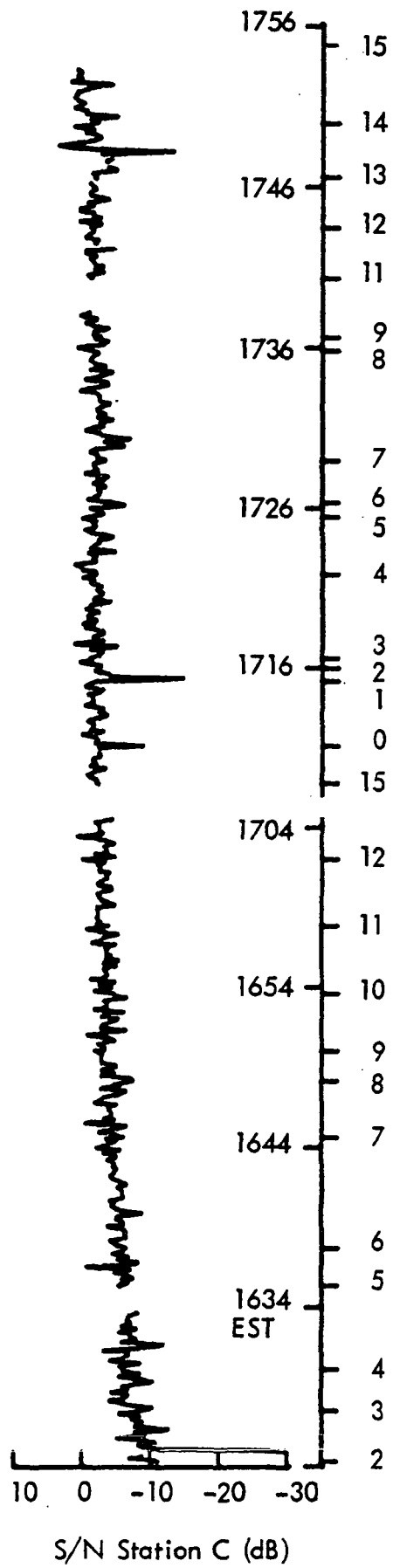

Figure A-41 . Flight 1-8, S/N Station C and D;
 WAL-racetrack (day, radar), 2/21/75, 3000', 1624-1750 EST, 2124-2250 GMT.

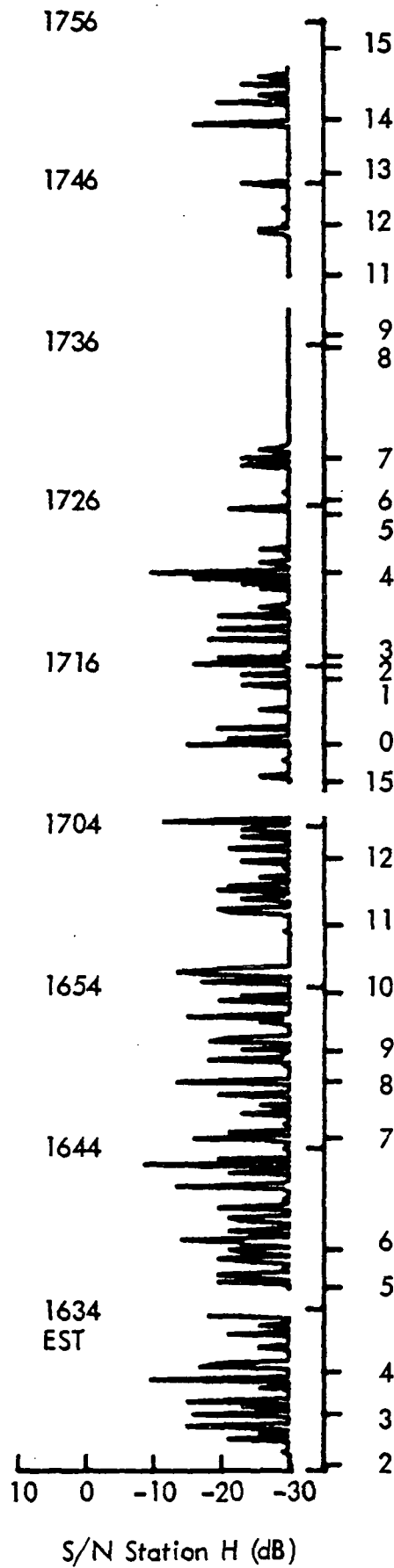

Figure A-42. Flight I-8, S/N Station H;
 WAL-racetrack (day, radar), 2/21/75, 3000', 1624-1750 EST, 2124-2250 GMT.

TEST DESCRIPTION

Flight No. 1-9

TEST OBJECTIVES: Provide same information as flight 1-8 but conducted at night with C band transponder on.

DATE: 2/21/75 DEPARTURE: WAL 1800 EST

DESTINATION: WAL ROUTE: Race track

ALTITUDE: 3000' WEATHER: VFR, calm

SUMMARY: Same as flight 1-8 except more severe oscillations in CDI.

KEY WORDS: Coast, LOP direction, diurnal, interference, radar.

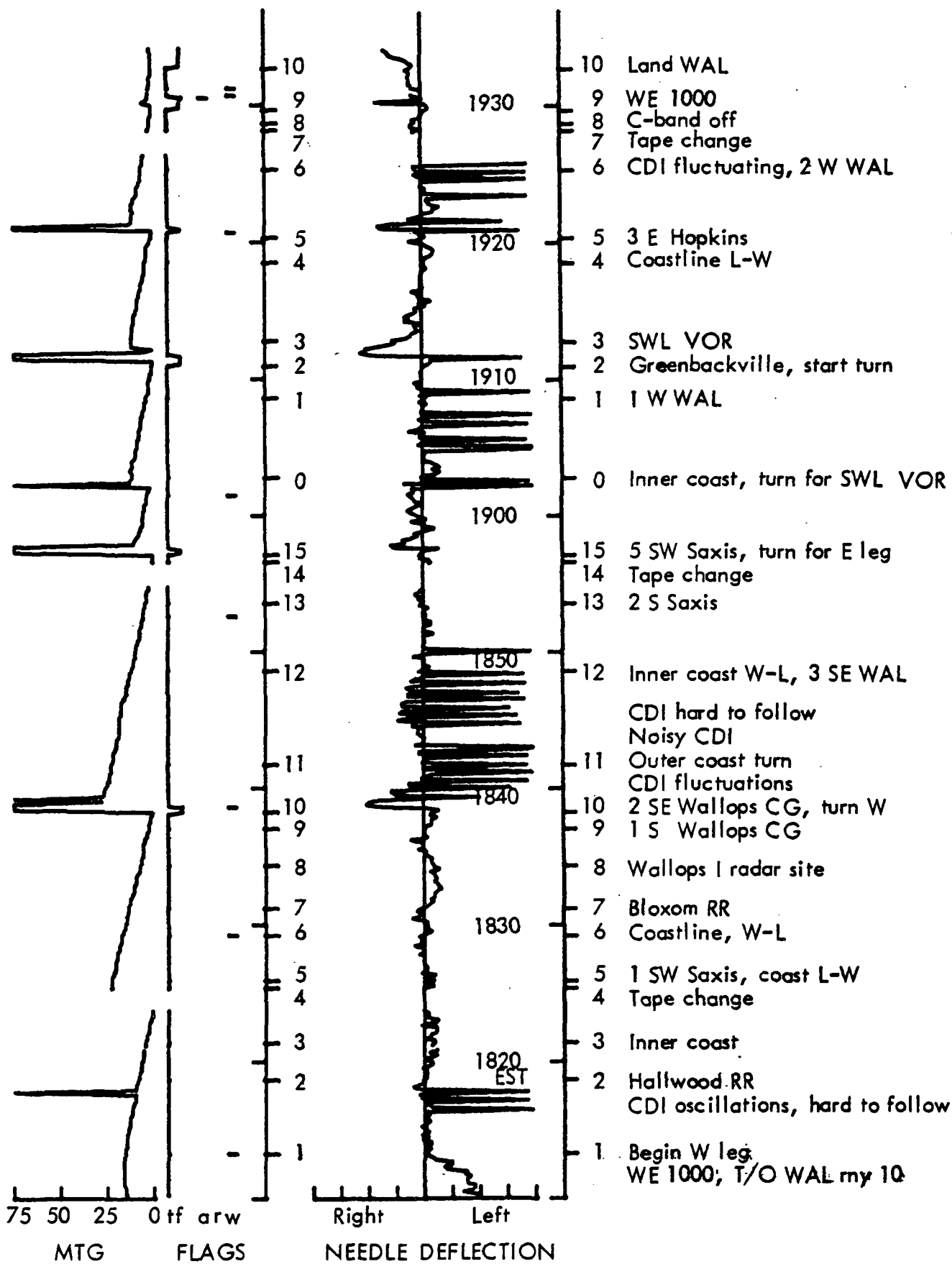

Figure A-43. Flight 1-9, Miles to Go and Needle Deflection;
WAL-racetrack (night, radar), 2/21/75, 3000', 1810-1935 EST, 2310-0035 GMT.

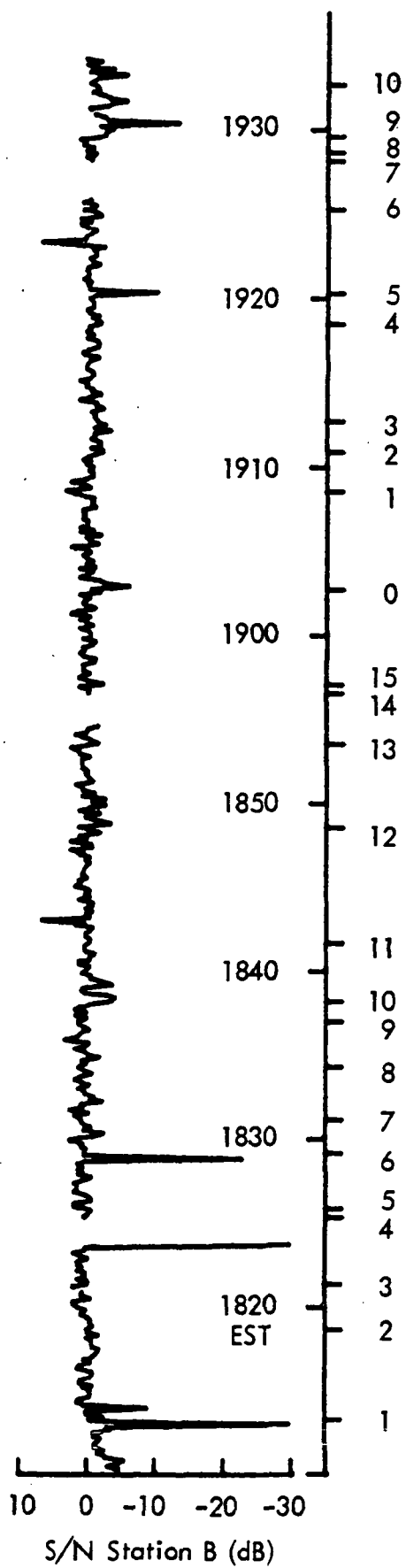
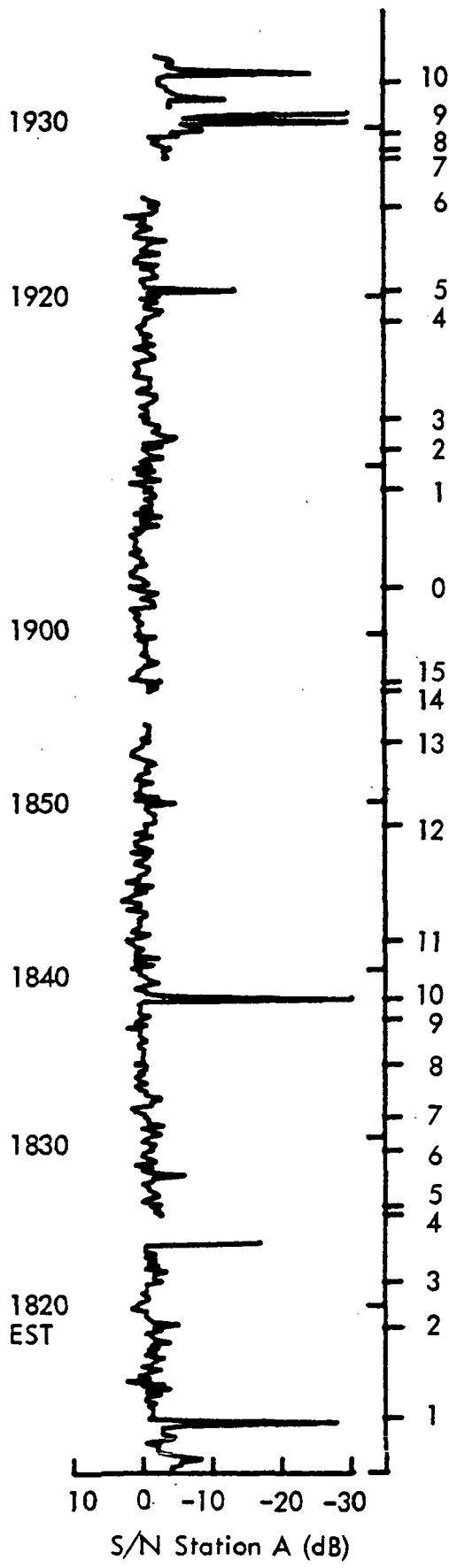

Figure A-44. Flight 1-9, S/N Station A and B;
 WAL-racetrack (night, radar), 2/21/75, 3000', 1810-1935 EST, 2310-0035 GMT.

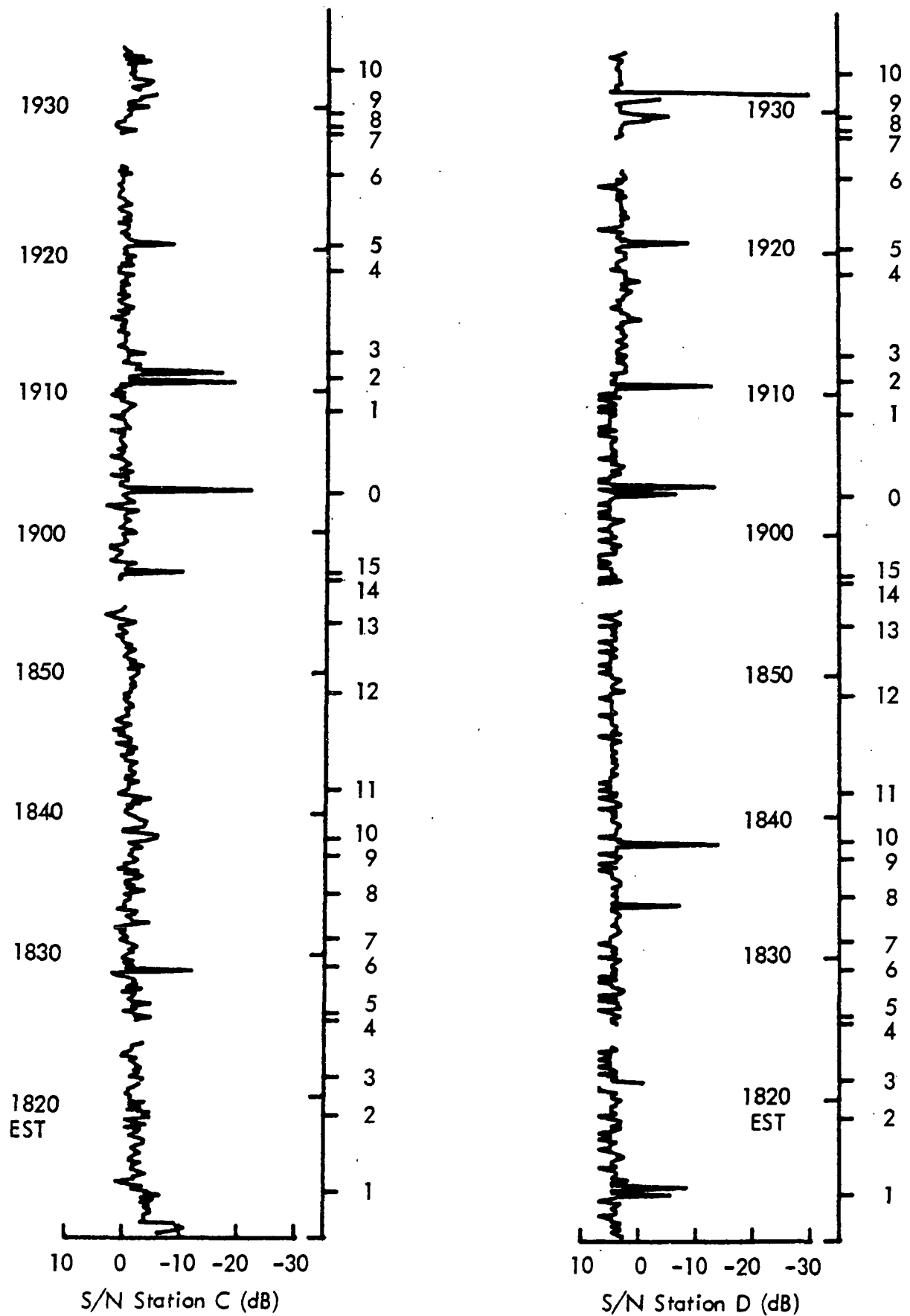

Figure A-45 . Flight 1-9, S/N Station C and D;
 WAL-racetrack (night, radar), 2/21/75, 3000', 1810-1935 EST, 2310-0035 GMT.

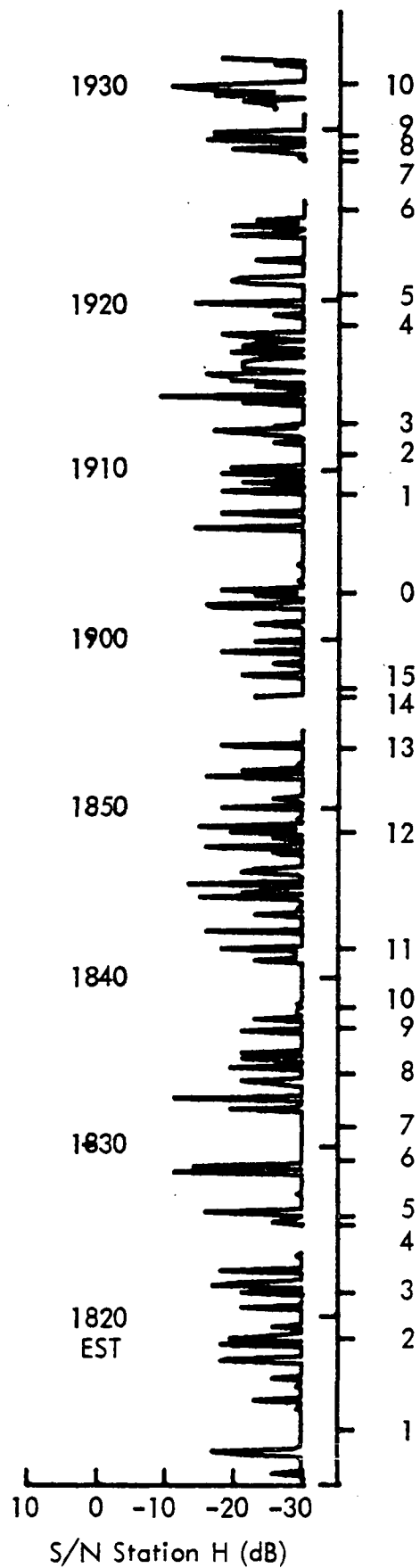

Figure A-46 . Flight 1-9, S/N Station H;
 WAL-racetrack (night, radar), 2/21/75, 3000', 1810-1935 EST, 2310-0035 GMT.

TEST DESCRIPTION

Flight No. 1-10

TEST OBJECTIVES: Provide additional S/N ratio data and accuracy information in SWL VOR area by flying VOR radials and comparing with Omega results, including Course number.

DATE: 2/22/75

DEPARTURE: WAL, 1140 EST

DESTINATION: SBY

ROUTE: SWL, constant 120° radial

ALTITUDE: 6000', 5000', 4000',
3000', and 2000'

WEATHER: VFR, 10 kts SW

SUMMARY: Flights out and back along the 120° SWL radial were made at various altitudes to investigate coastline and interference effects at various altitudes. Considerable coast effect was evident in Omega indicator and considerable scalloping in VOR at lower altitudes.

KEY WORDS: Altitude, coast, interference.

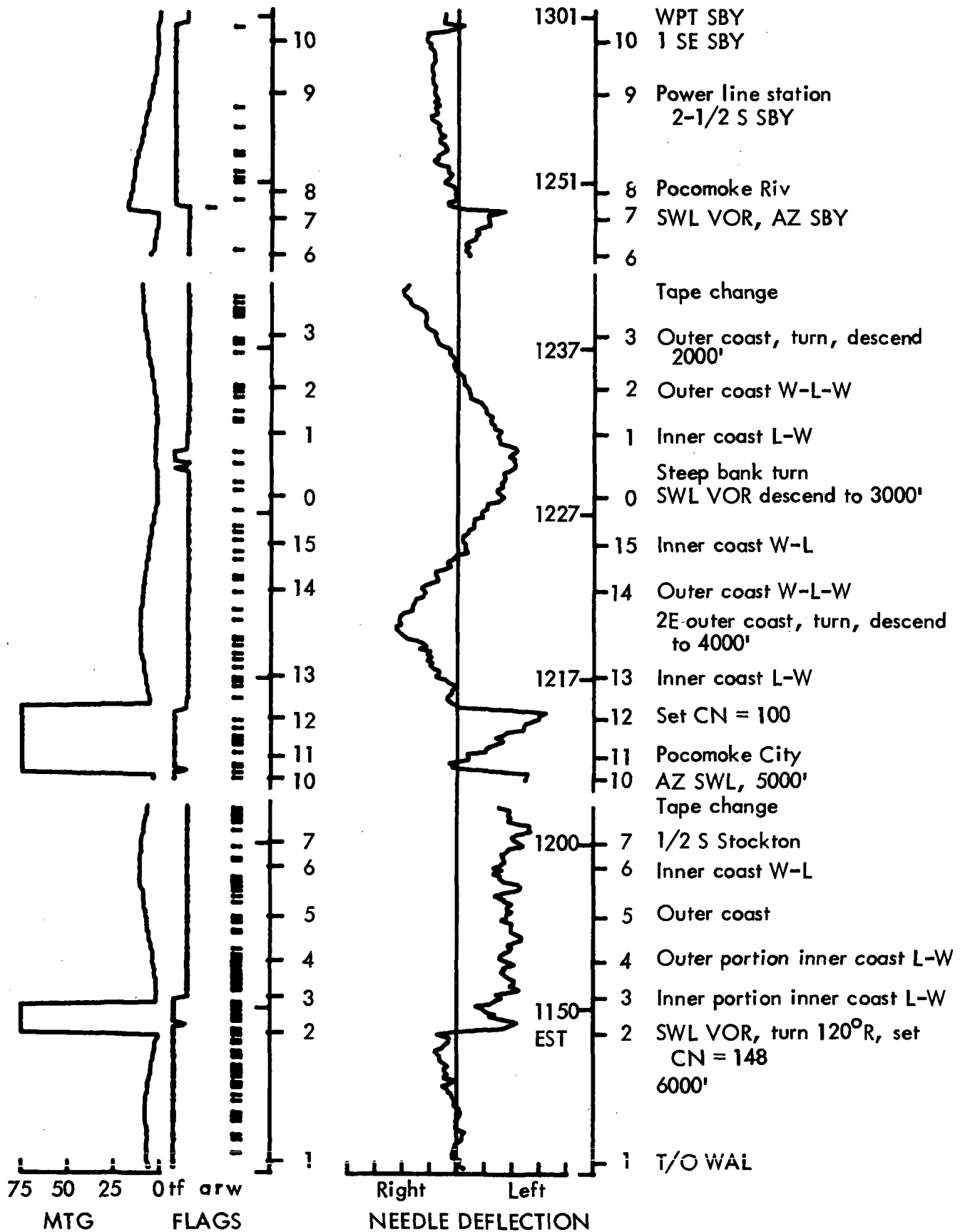

Figure A-47. Flight 1-10, Miles to Go and Needle Deflection;
WAL-SWL-SBY, 2/22/75, Vary Alt., 1140-1250 EST, 1640-1750 GMT.

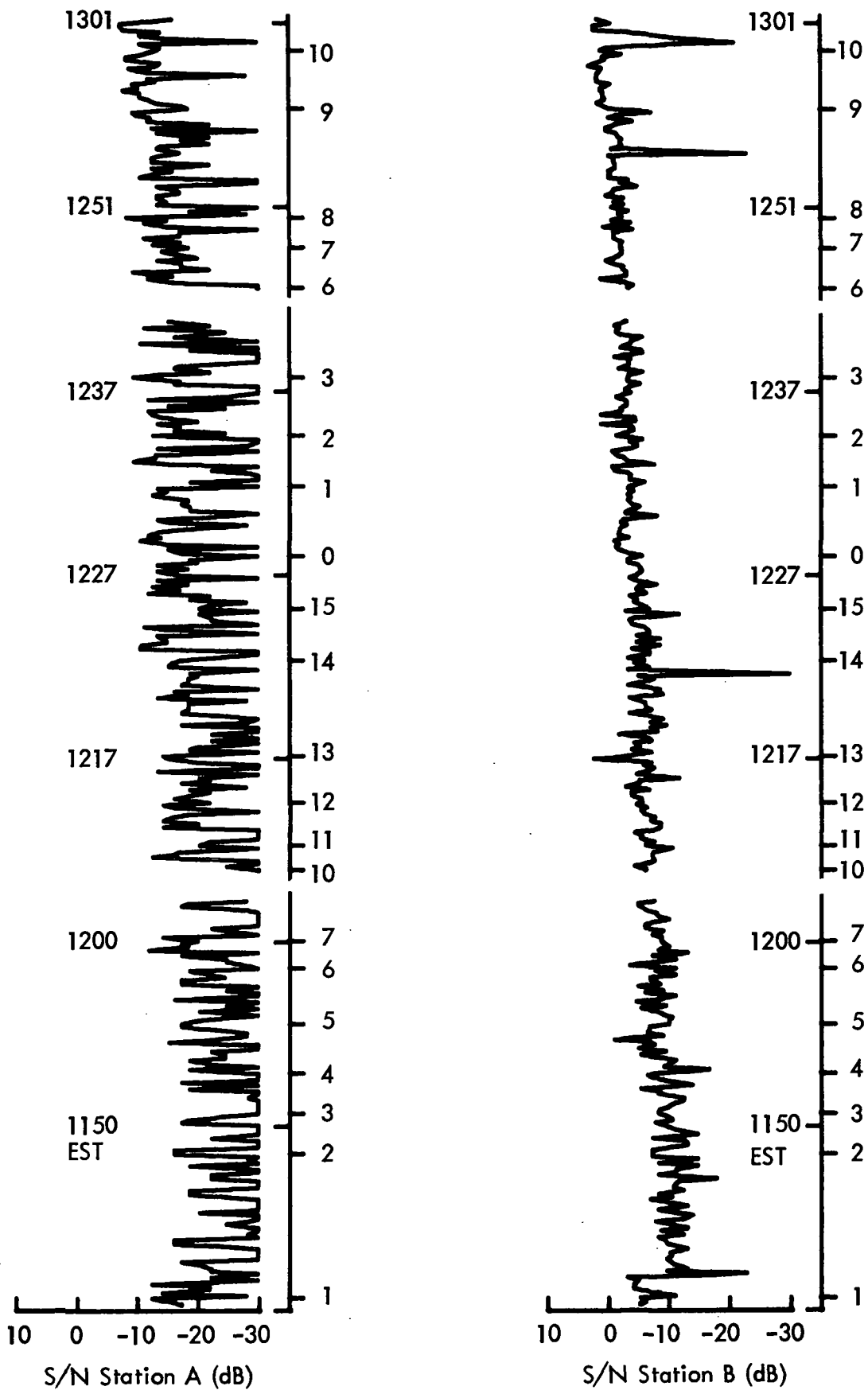

Figure A-48 . Flight 1-10, S/N Station A and B;
 WAL-SWL-SBY, 2/22/75, Vary Alt., 1140-1250 EST, 1640-1750 GMT.

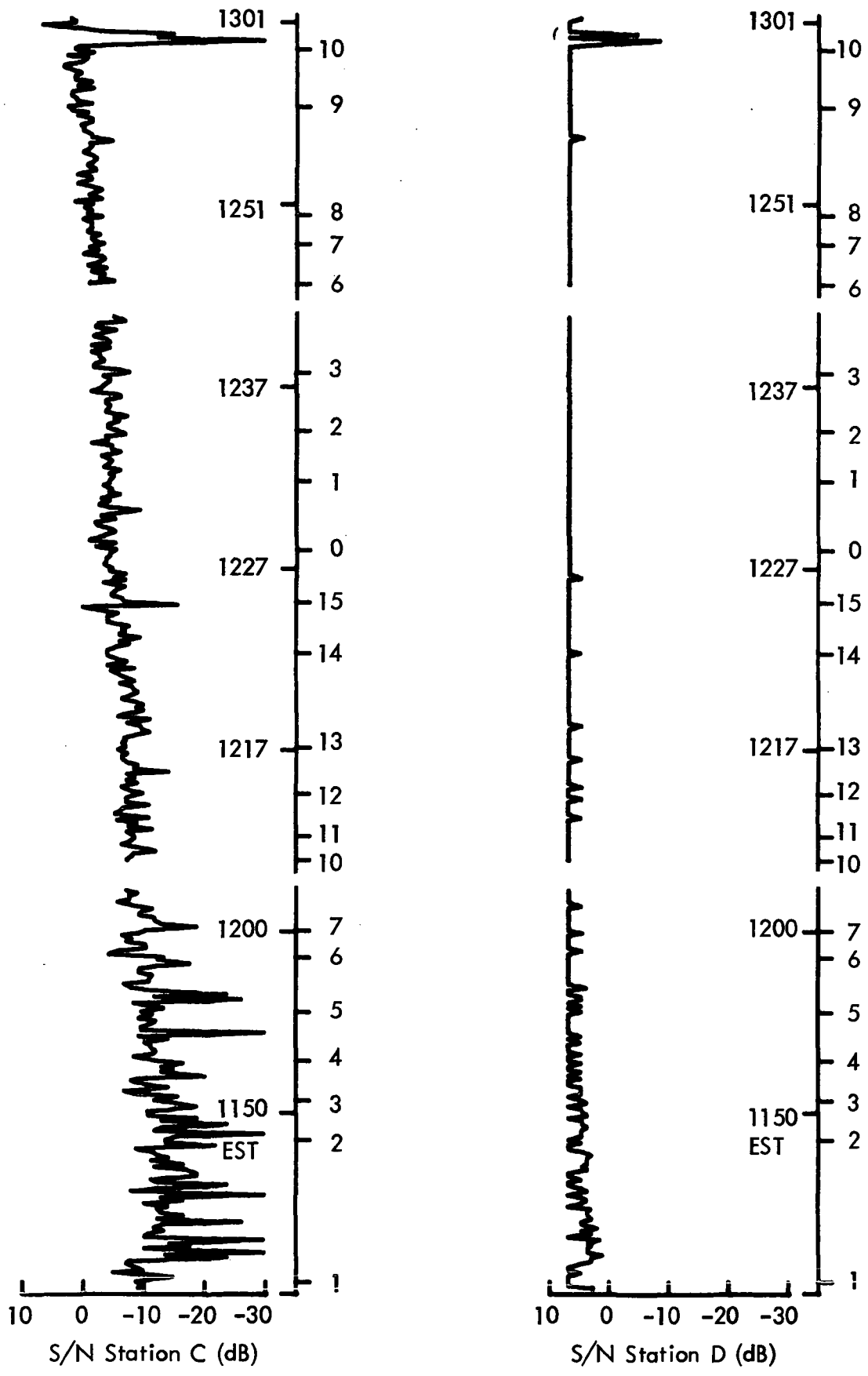

Figure A-49 . Flight 1-10, S/N Station C and D;
 WAL-SWL-SBY, 2/22/75, Vary Alt., 1140-1250 EST, 1640-1750 GMT.

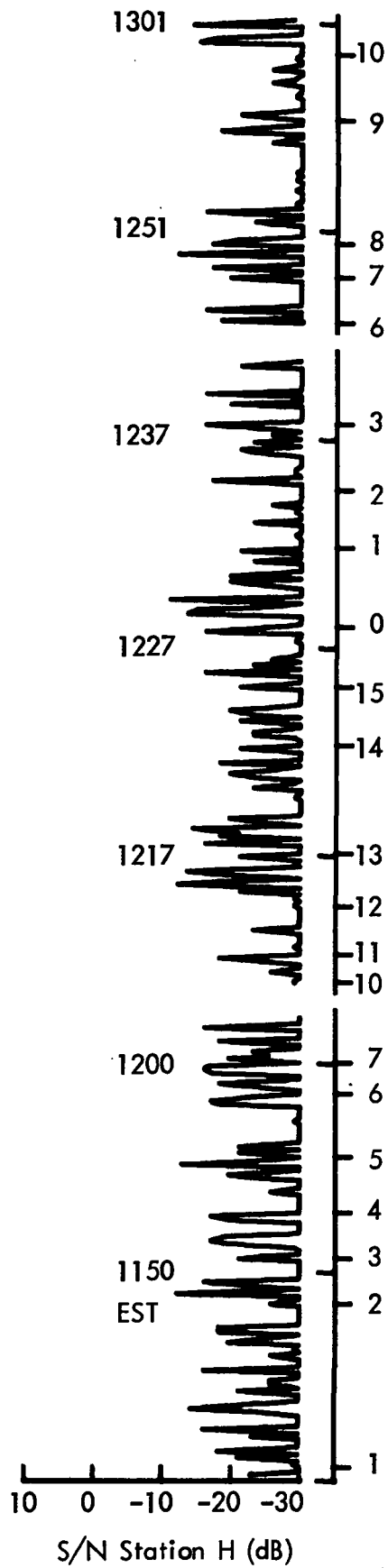

Figure A-50 . Flight 1-10, S/N Station H;
 WAL-SWL-SBY, 2/22/75, Vary Alt., 1140-1250 EST, 1640-1750 GMT.

TEST DESCRIPTION

Flight No. 1-20

TEST OBJECTIVES: Provide S/N data along power lines and in vicinity of SWL VOR.

DATE: 3/7/75

DEPARTURE: SBY, 1355 EDT

DESTINATION: WAL

ROUTE: via SWL VOR

ALTITUDE: 2000'

WEATHER: VFR, 10 kts, S

SUMMARY: Determined CIU difficulty enroute and recorded only last two thirds of flight. Used A-C and B-D LOP pair.

KEY WORDS: Station pairs, LOP direction, interference.

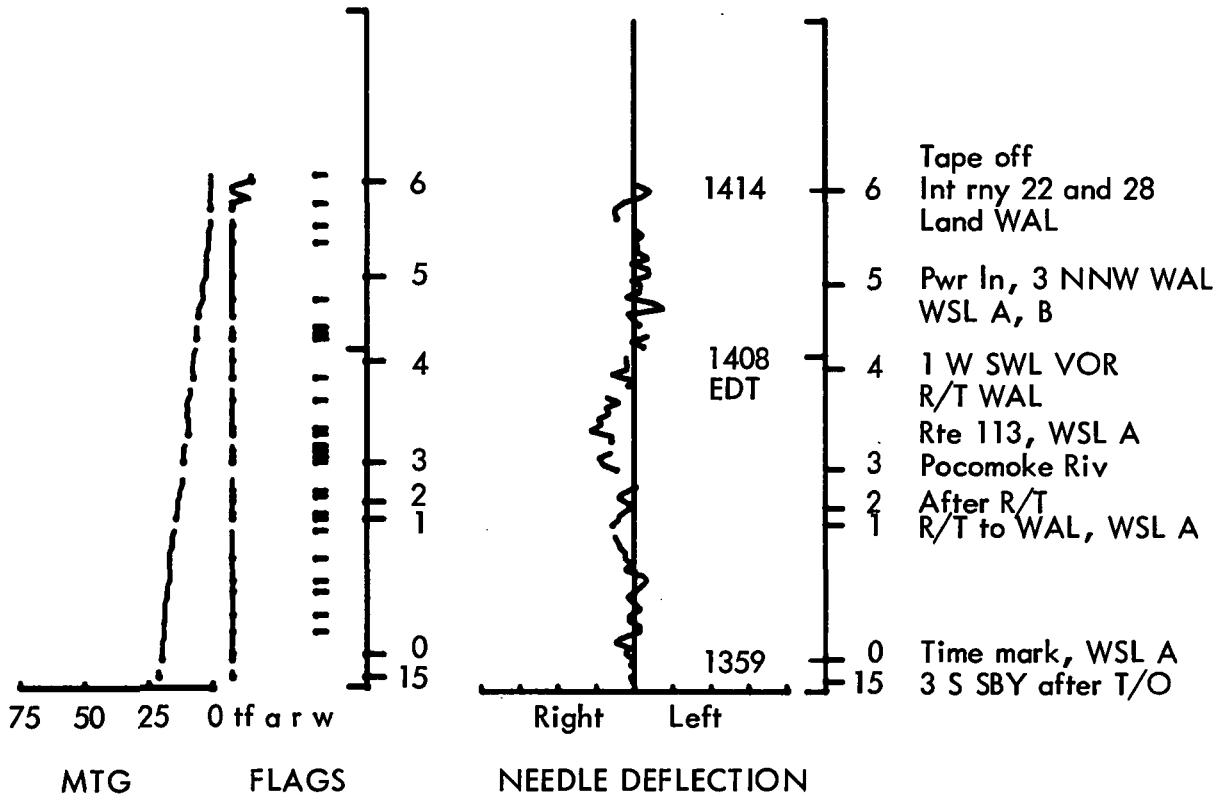
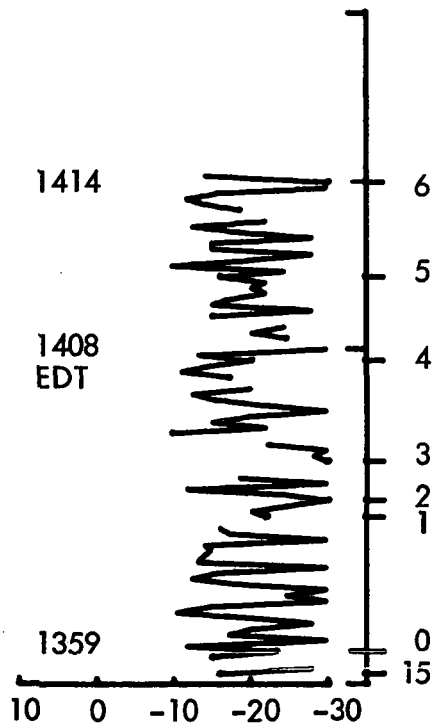
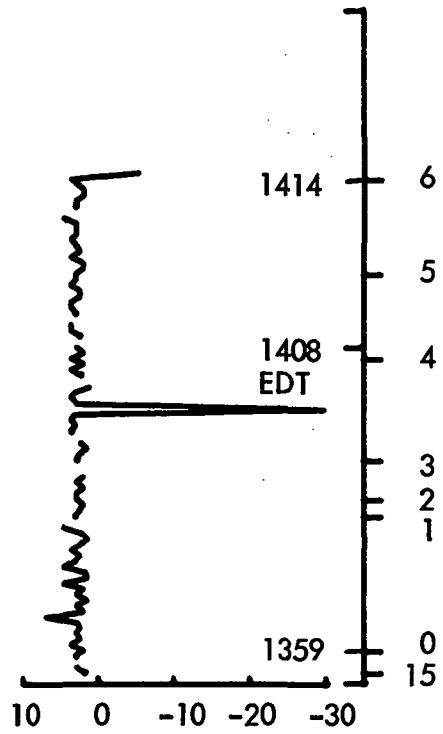
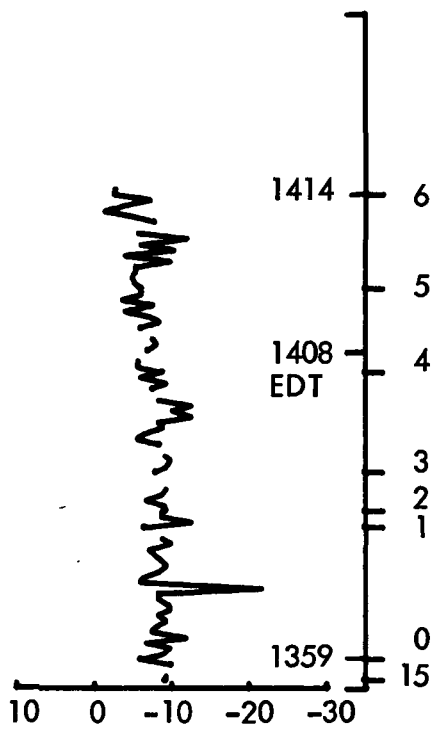
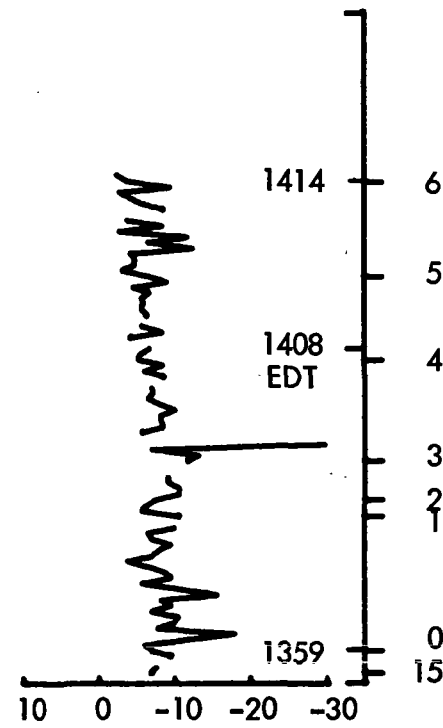

Figure A-51 . Flight 1-20 (Last 16 min.), Miles to Go and Needle Deflection;
SBY-WAL, 3/7/75, 1500', 1355-1415 EDT, 1755-1815 GMT.



S/N Station A (dB)



S/N Station B (dB)

Figure A-52 . Flight 1-20 (Last 16 min.), S/N Station A, B, C and D;
 SBY-WAL, 3/7/75, 1500', 1355-1415 EDT, 1755-1815 GMT.

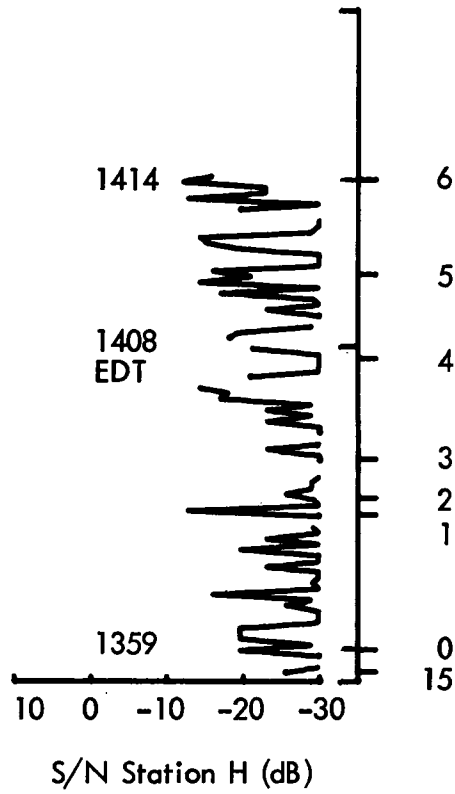

Figure A-53. Flight 1-20 (Last 16 min.), S/N Station H; SBY-WAL, 3/7/75, 1500', 1355-1415 EDT, 1755-1815 GMT.

TEST DESCRIPTION

Flight No. 1-21

TEST OBJECTIVES: Obtain S/N data in precipitation (rain), test results of precipitation on accuracy in the Wallops area. Use different LOP pairs for comparison.

DATE: 3/7/75

DEPARTURE: WAL, 1615 EDT

DESTINATION: SBY

ROUTE: New Church, Kellam
(via railroad)

ALTITUDE: 1000'

WEATHER: Alternate, moderate and
heavy rain

SUMMARY: Flight in heavy rain showers produced no observable degradation of S/N ratio or difficulties in navigation. Voice tape for second half of flight was lost. North bound leg along railroad employed A-C and B-D LOP waypoint to SWL.

KEY WORDS: Station pairs, precipitation, interference.

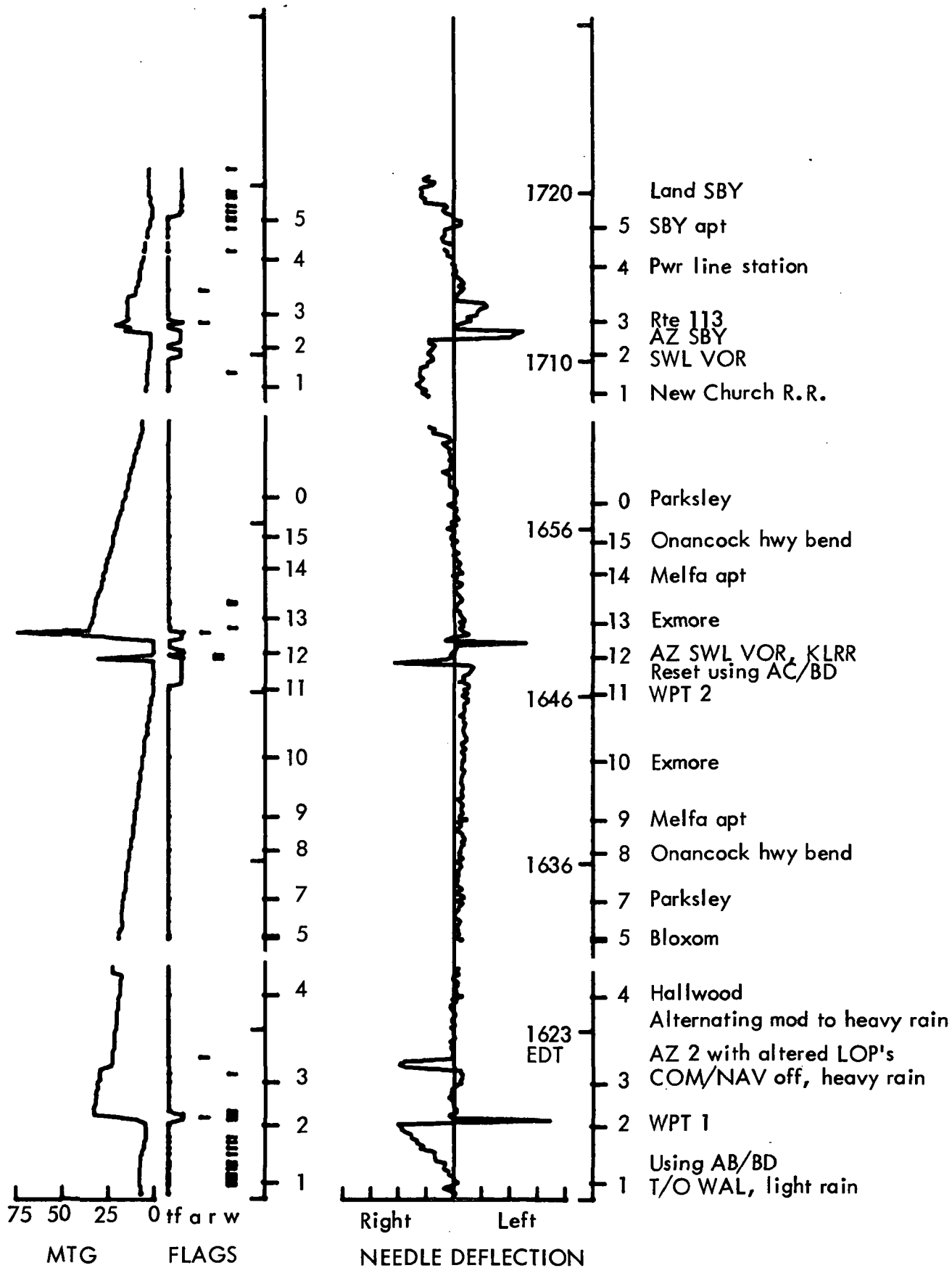

Figure A-54. Flight 1-21, Miles to Go and Needle Deflection;
WAL-R.R.-SBY (Rain), 3/7/75, 1000', 1613-1722 EDT, 2013-2122 GMT.

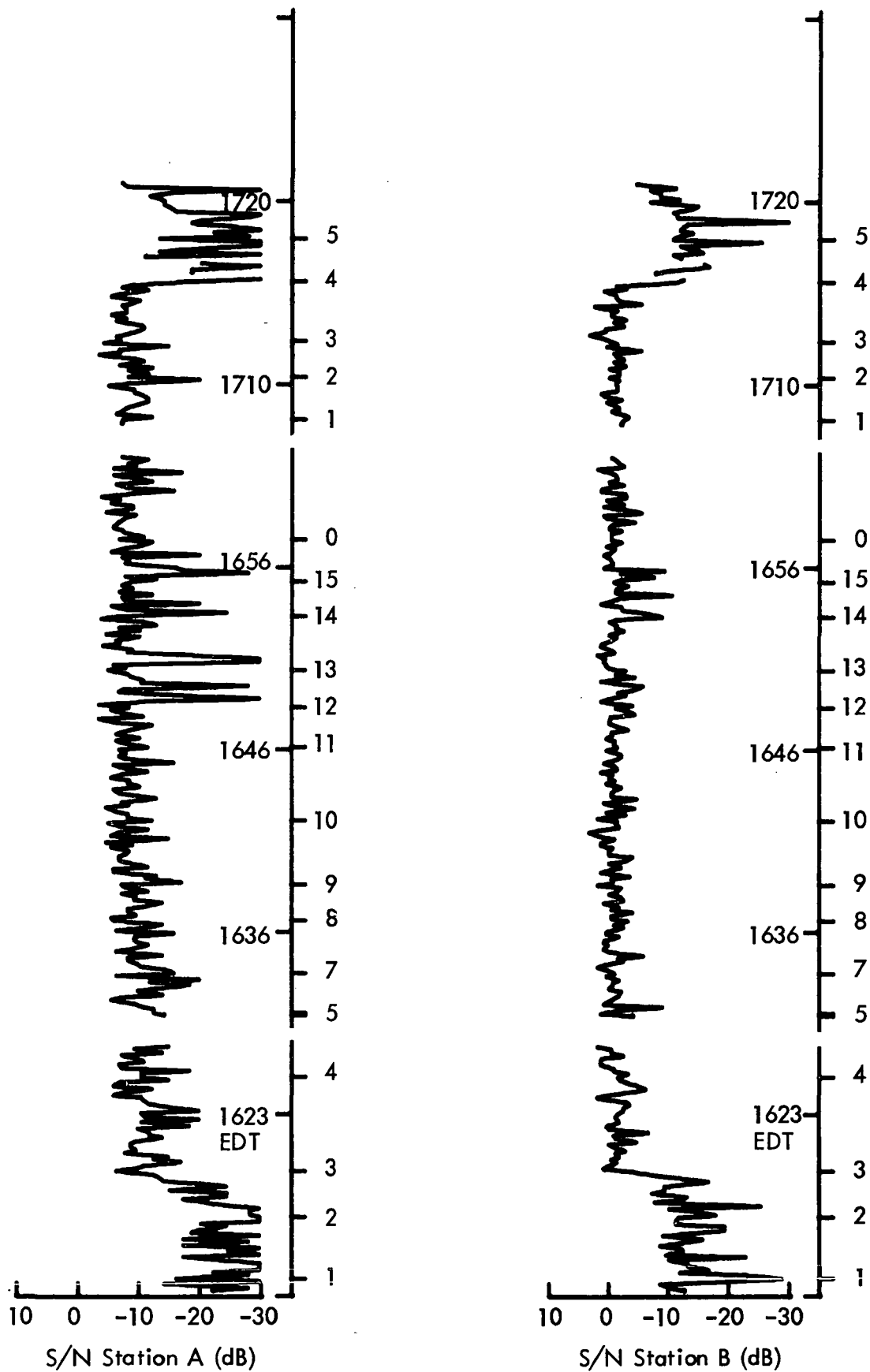

Figure A-55. Flight 1-21, S/N Station A and B;
 WAL-R.R.-SBY (Rain), 3/7/75, 1000', 1613-1722 EDT, 2013-2122 GMT.

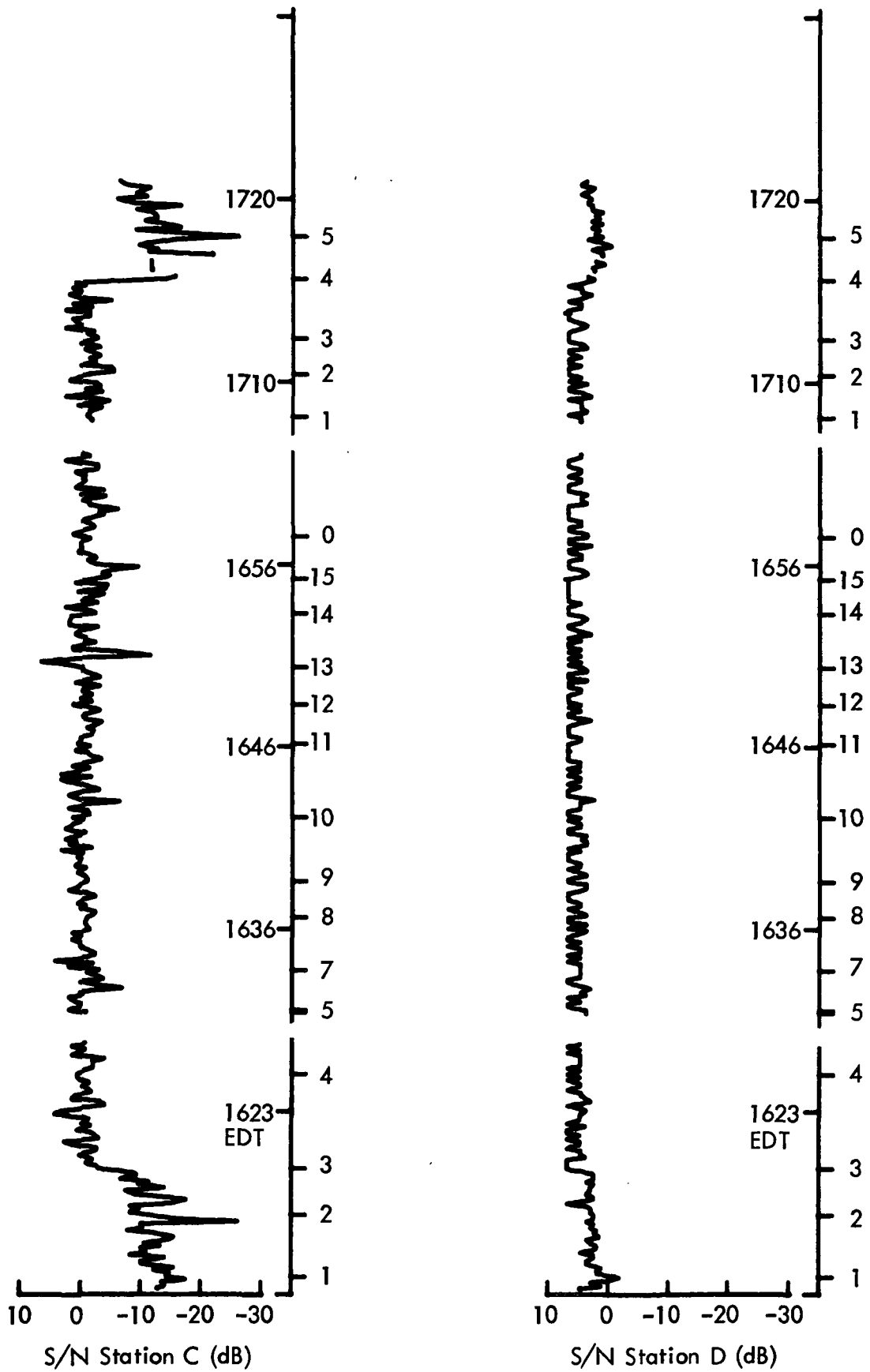

Figure A-56. Flight 1-21, S/N Station C and D;
WAL-R.R.-SBY (Rain), 3/7/75, 1000', 1613-1722 EDT, 2013-2122 GMT.

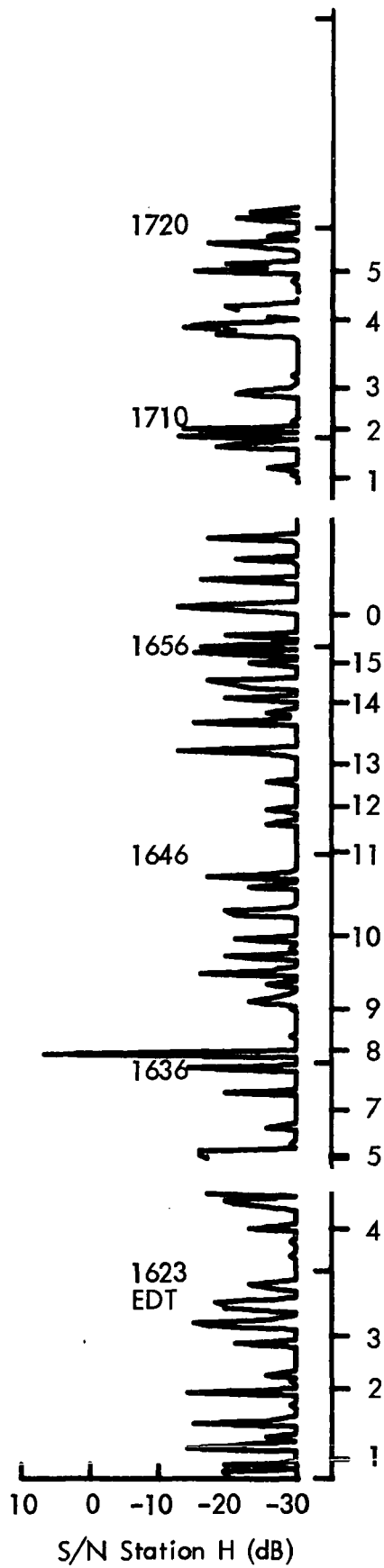

Figure A-57. Flight 1-21, S/N Station H;
 WAL-R.R.-SBY (Rain), 3/7/75, 1000', 1613-1722 EDT, 2013-2122 GMT.

TEST DESCRIPTION

Flight No. 1-22

TEST OBJECTIVES: Obtain position accuracy checks as a function of LOP pair selection, test coastline effects on various LOP pairs, flying along constant LOP.

DATE: 3/8/75

DEPARTURE: SBY, 1011 EDT

DESTINATION: SBY

ROUTE: Constant LOP from SWL

ALTITUDE: 2000'

WEATHER: VFR, 6000' broken ceiling
moderate turbulence

SUMMARY: Flew along constant AC LOP (+ 1 AB lane), constant AD LOP, constant AB LOP (+ 1 AD lane), constant BD LOP, constant BC LOP. Climbed to 7200 ft to determine cloud tops. Moderate turbulence along route of flight.

KEY WORDS: Altitude, coast, station pairs, LOP direction, interference, maneuvers.

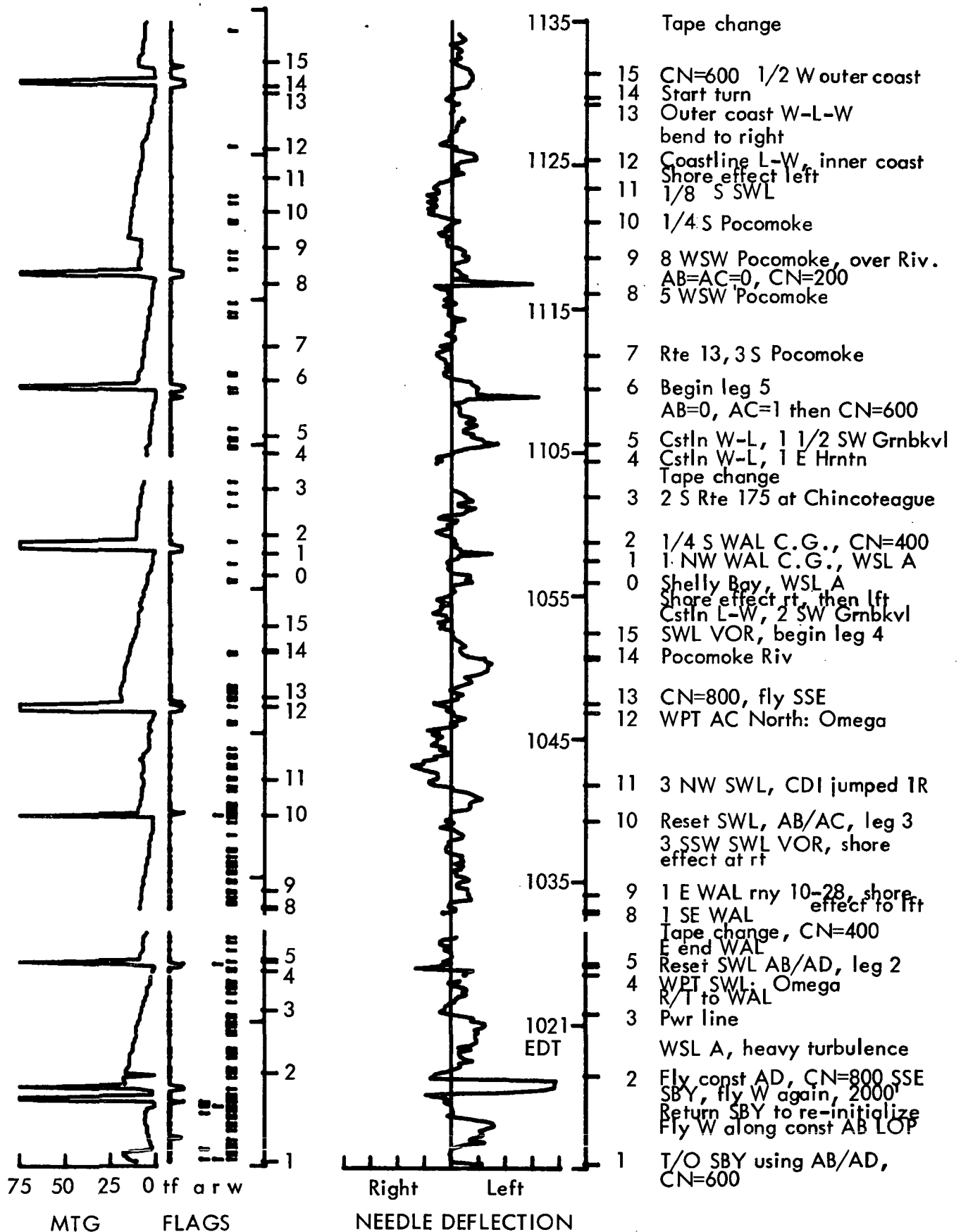

Figure A-58. Flight 1-22 (First 81 min.), Miles to Go and Needle Deflection
 SBY-SWL-LOP's, 3/8/75, 3500', 1000-1256 EDT, 1400-1656 GMT.

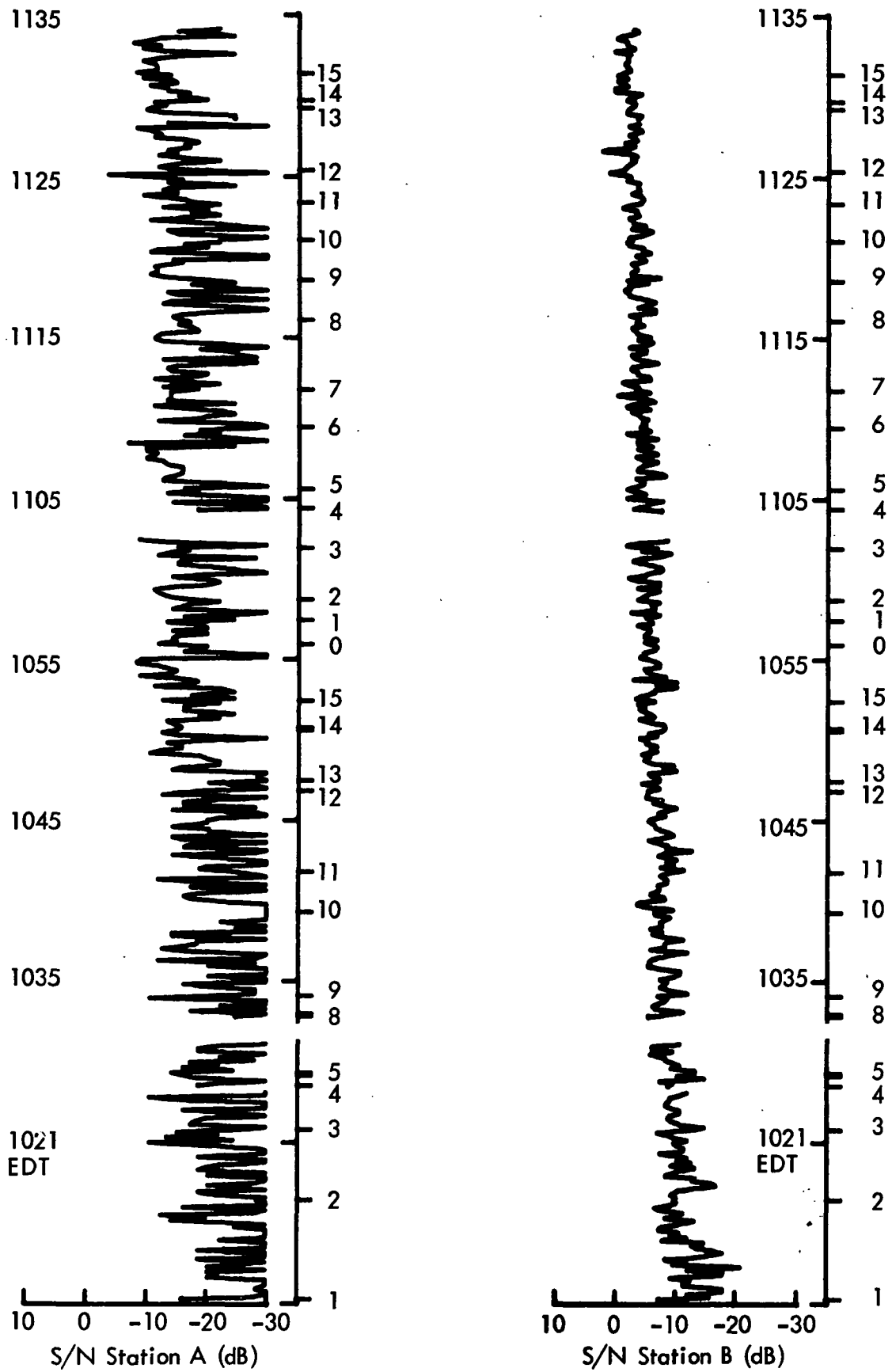

Figure A-59. Flight 1-22 (First 81 min.), S/N Station A and B; SBY-SWL-LOP's, 3/8/75, 3500', 1000-1256 EDT, 1400-1656 GMT.

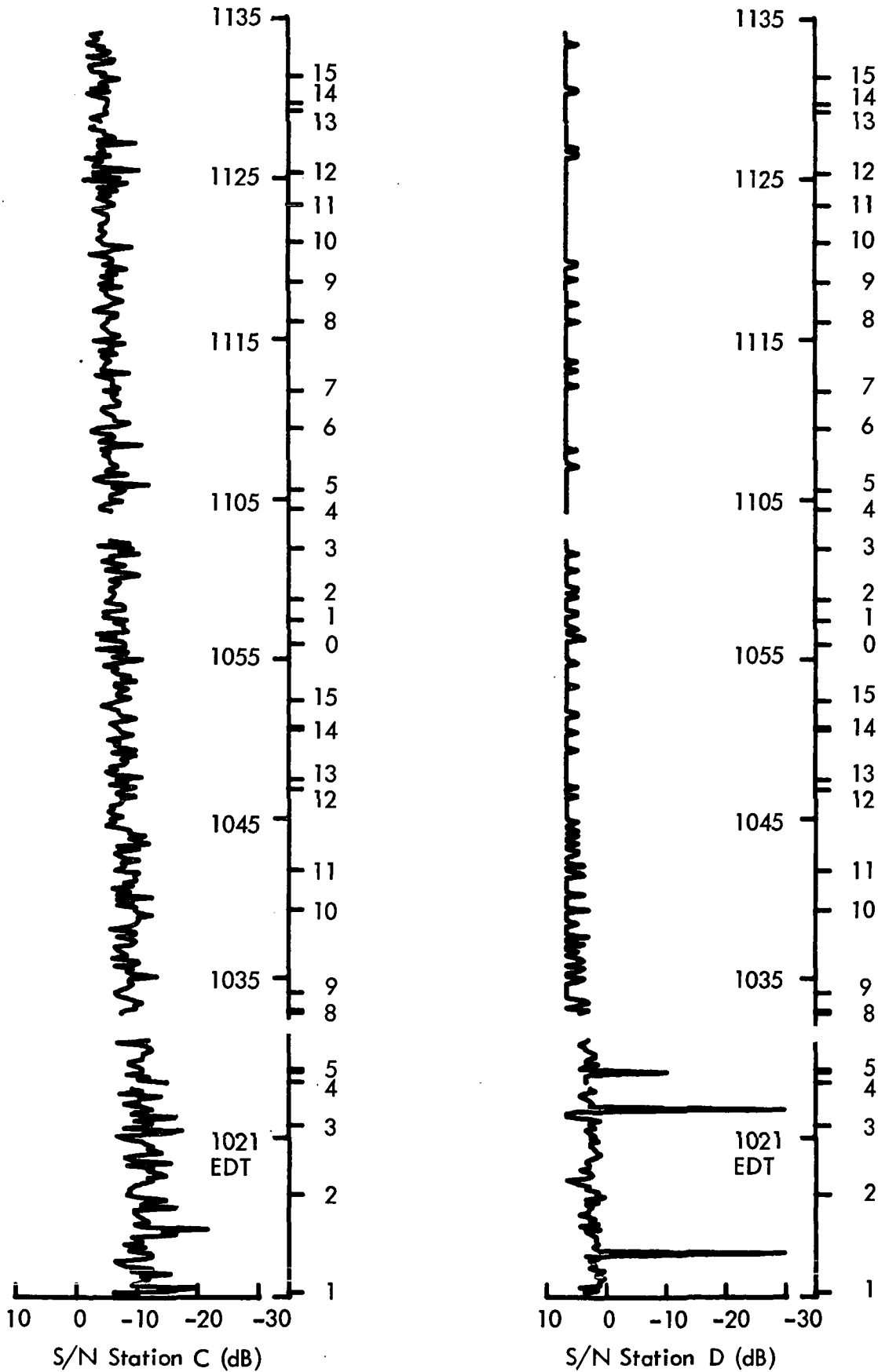

Figure A-60. Flight 1-22 (First 81 min.), S/N Station C and D; SBY-SWL-LOP's, 3/8/75, 3500', 1000-1256 EDT, 1400-1656 GMT.

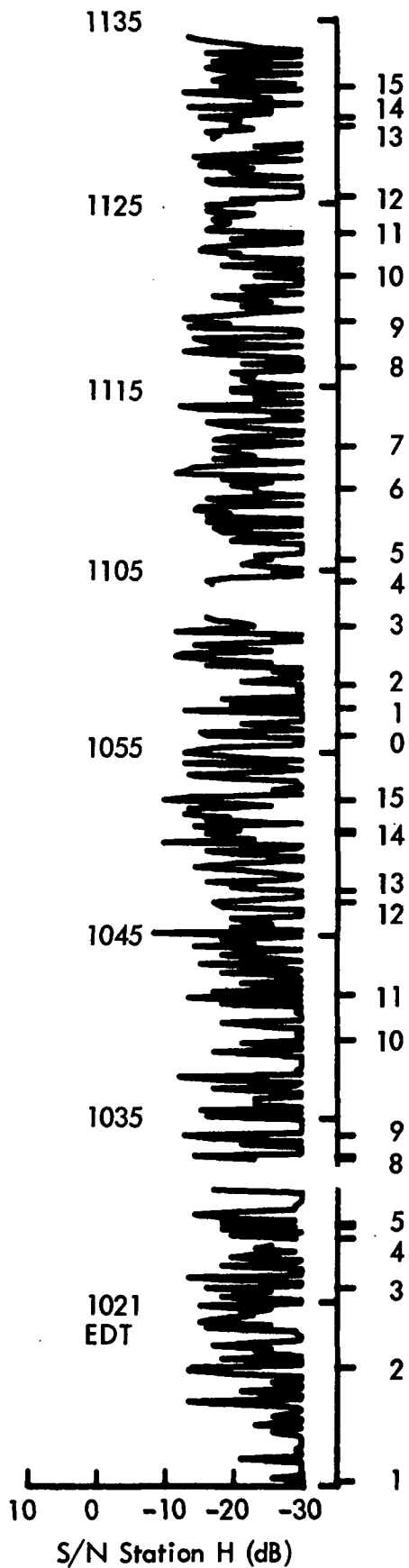

Figure A-61 . Flight 1-22 (First 81 min.), S/N Station H;
 SBY-SWL-LOP's, 3/8/75, 3500', 1000-1256 EDT, 1400-1656 GMT.

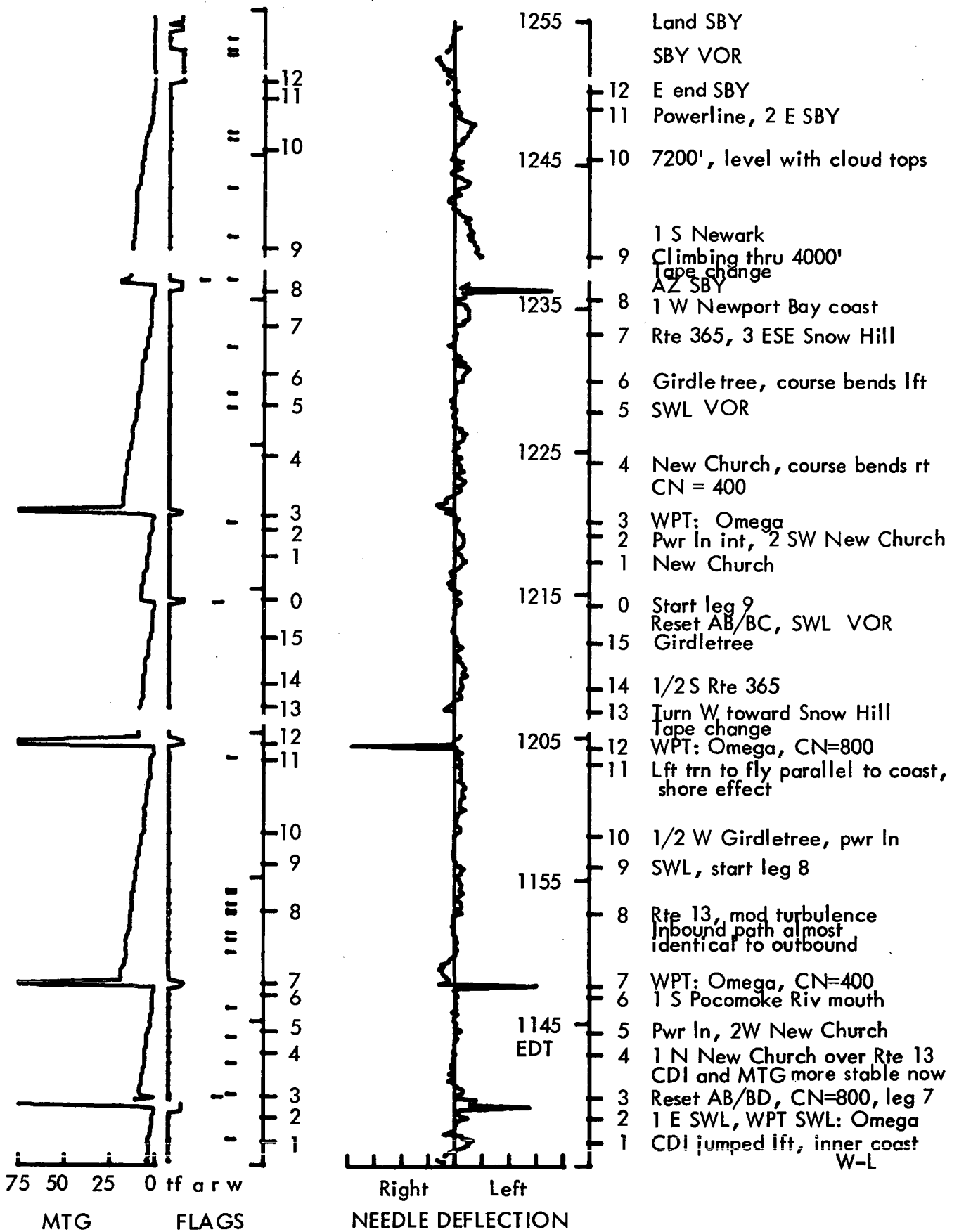

Figure A-62. Flight 1-22 (Second 80 min.), Miles to Go and Needle Deflection; SBY-SWL-LOP's, 3/8/75, 3500', 1000-1256 EDT, 1400-1656 GMT.

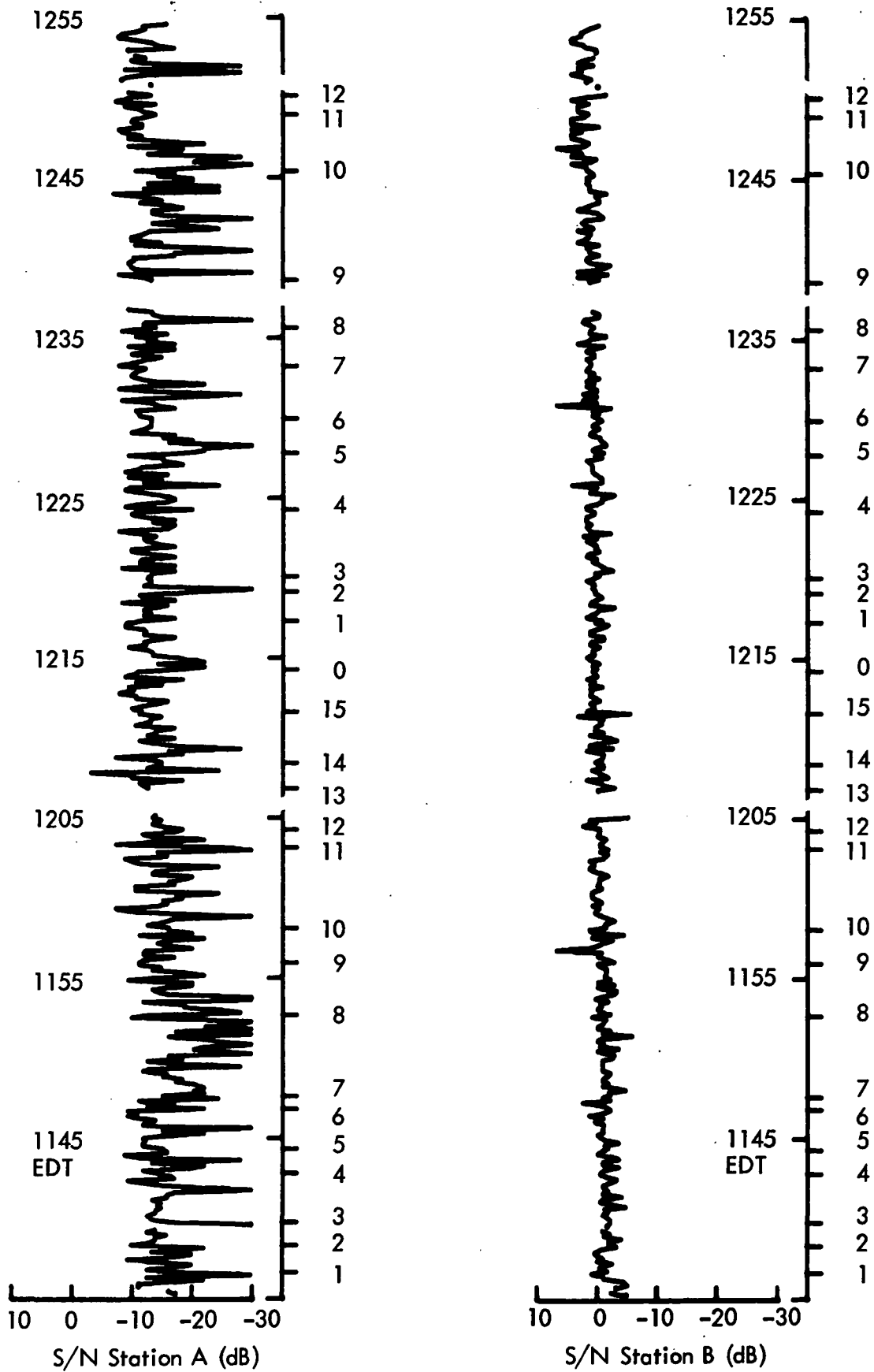

Figure A-63 . Flight 1-22 (Second 80 min.), S/N Station A and B;
 SBY-SWL-LOP's, 3/8/75, 3500', 1000-1256 EDT, 1400-1656 GMT.

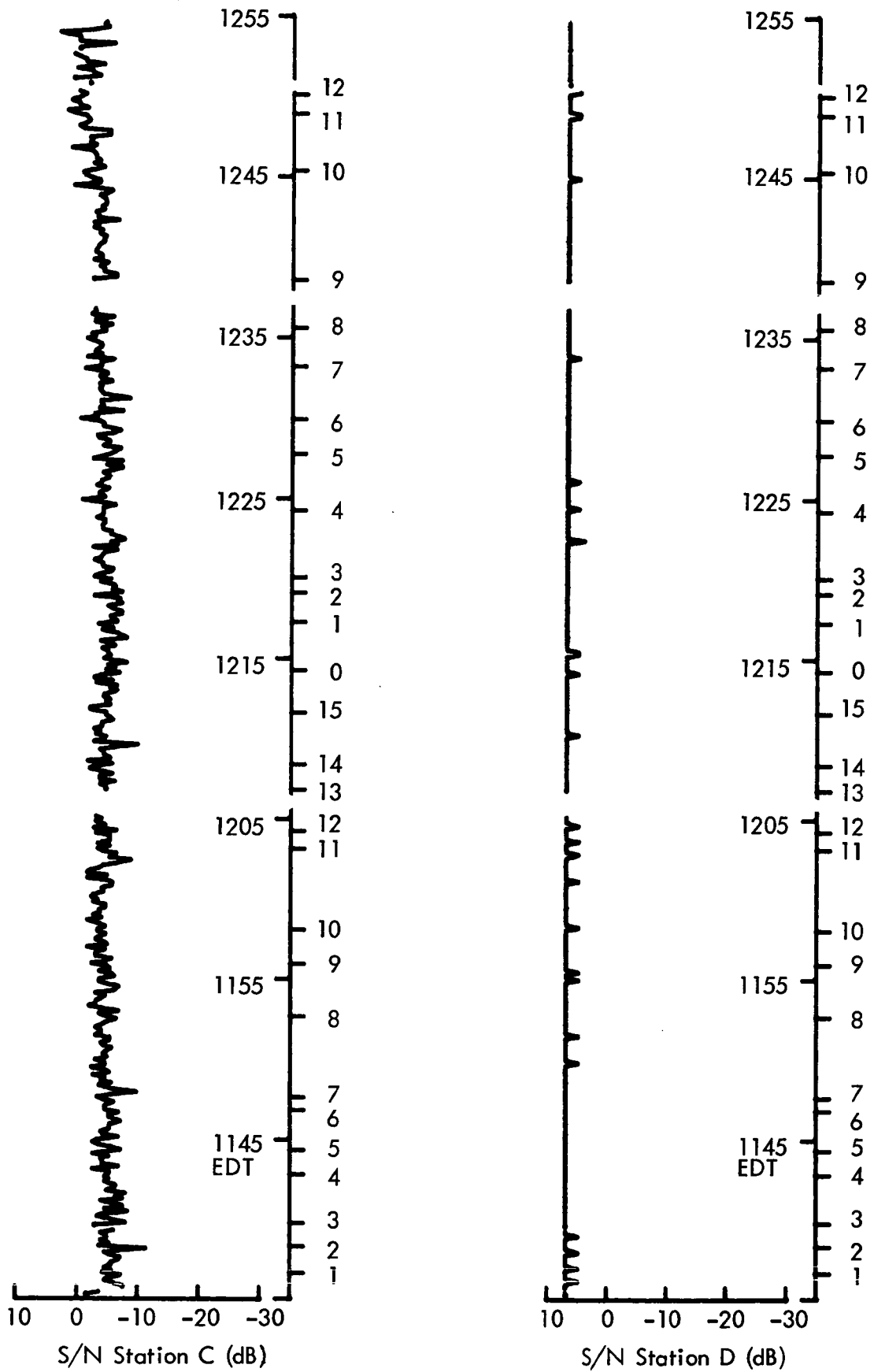

Figure A-64. Flight 1-22 (Second 80 min.), S/N Station C and D; SBY-SWL-LOP's, 3/8/75, 3500', 1000-1256 EDT, 1400-1656 GMT.

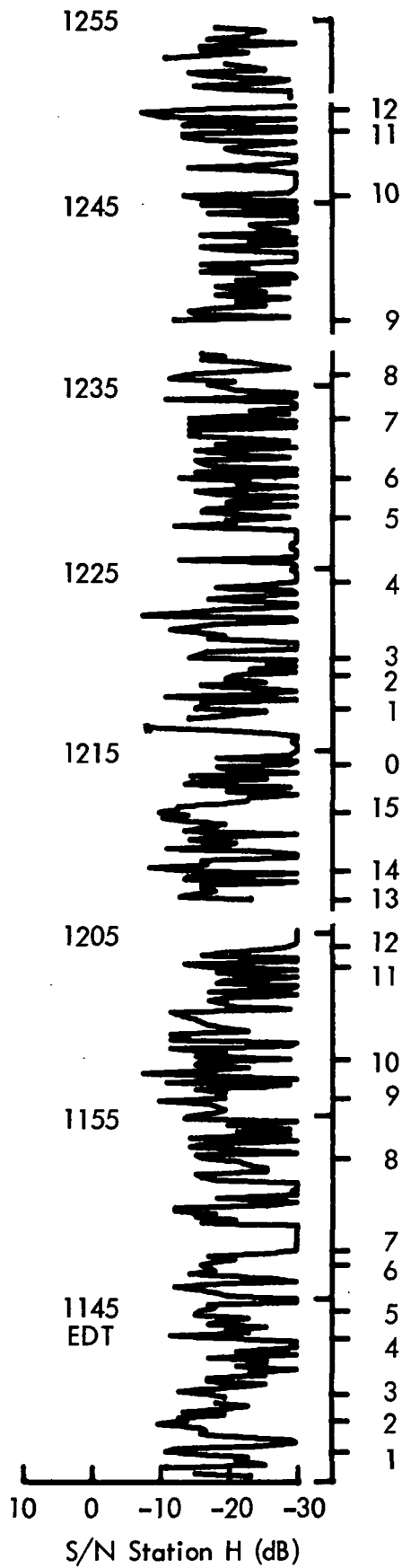

Figure A-65. Flight 1-22 (Second 80 min.), S/N Station H;
 SBY-SWL-LOP's, 3/8/75, 3500', 1000-1256 EDT, 1400-1656 GMT.

TEST DESCRIPTION

Flight No. 1-23

TEST OBJECTIVES: Compare Omega course numbers along SWL VOR radials to determine magnitude and direction of coastline effects. Check waypoint accuracy.

DATE: 3/8/75 DEPARTURE: SBY, 1556 EDT
DESTINATION: SBY ROUTE: VOR Cloverleaf (15^o radial)
ALTITUDE: 3300' WEATHER: VFR, 6000' broken,
20 kts, NNW

SUMMARY: Cloverleaf was flown to minimize upwind flying. Observed coast effect: scallops half mile in magnitude. No local interference near SWL. Returned within one mile of waypoint each time.

KEY WORDS: Coast, interference.

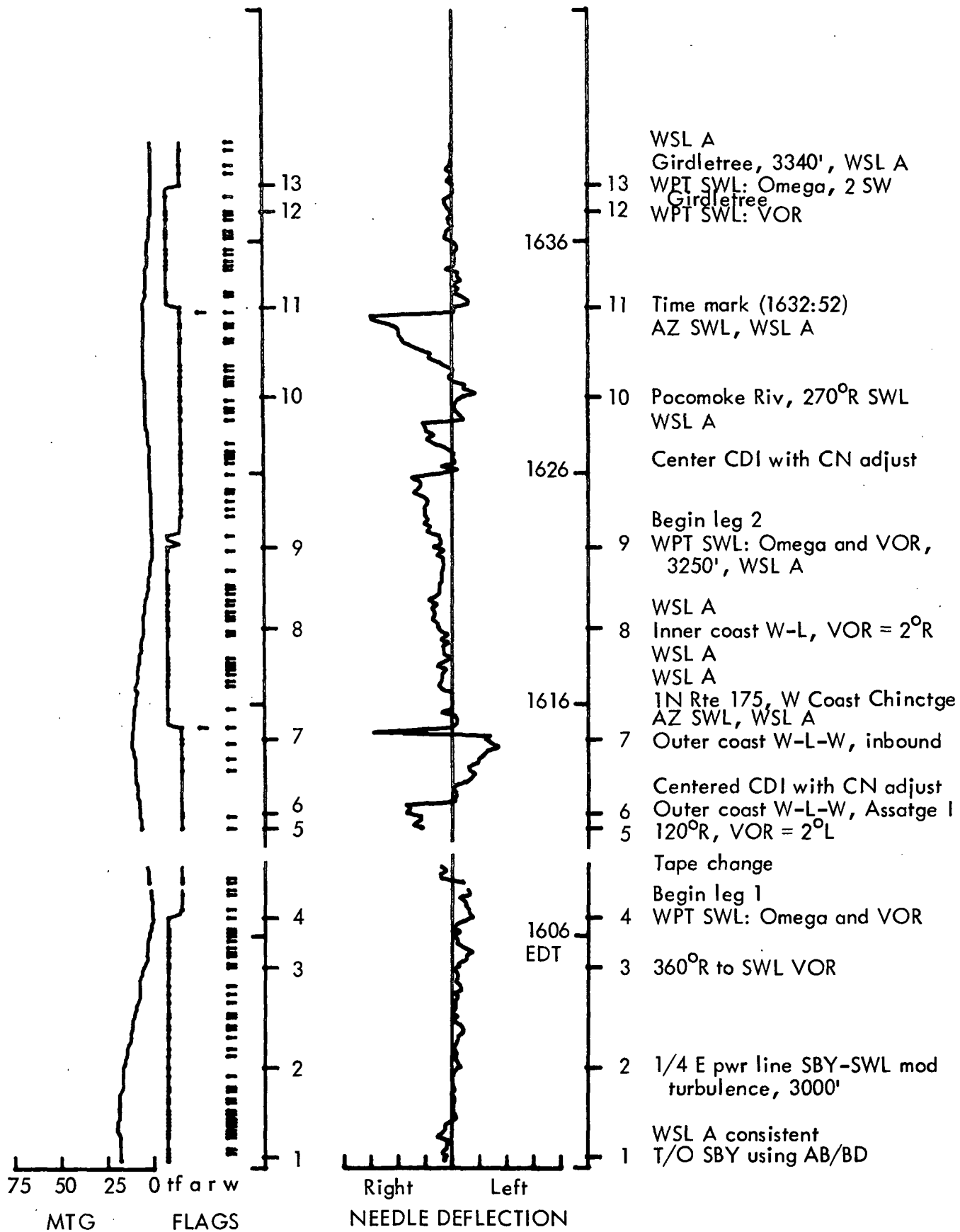

Figure A-66 . Flight 1-23 (First 44 Min), Miles to Go and Needle Deflection;
SWL VOR Cloverleaf, 3/8/75, 3300', 1556-1747 EDT, 1956-2147 GMT.

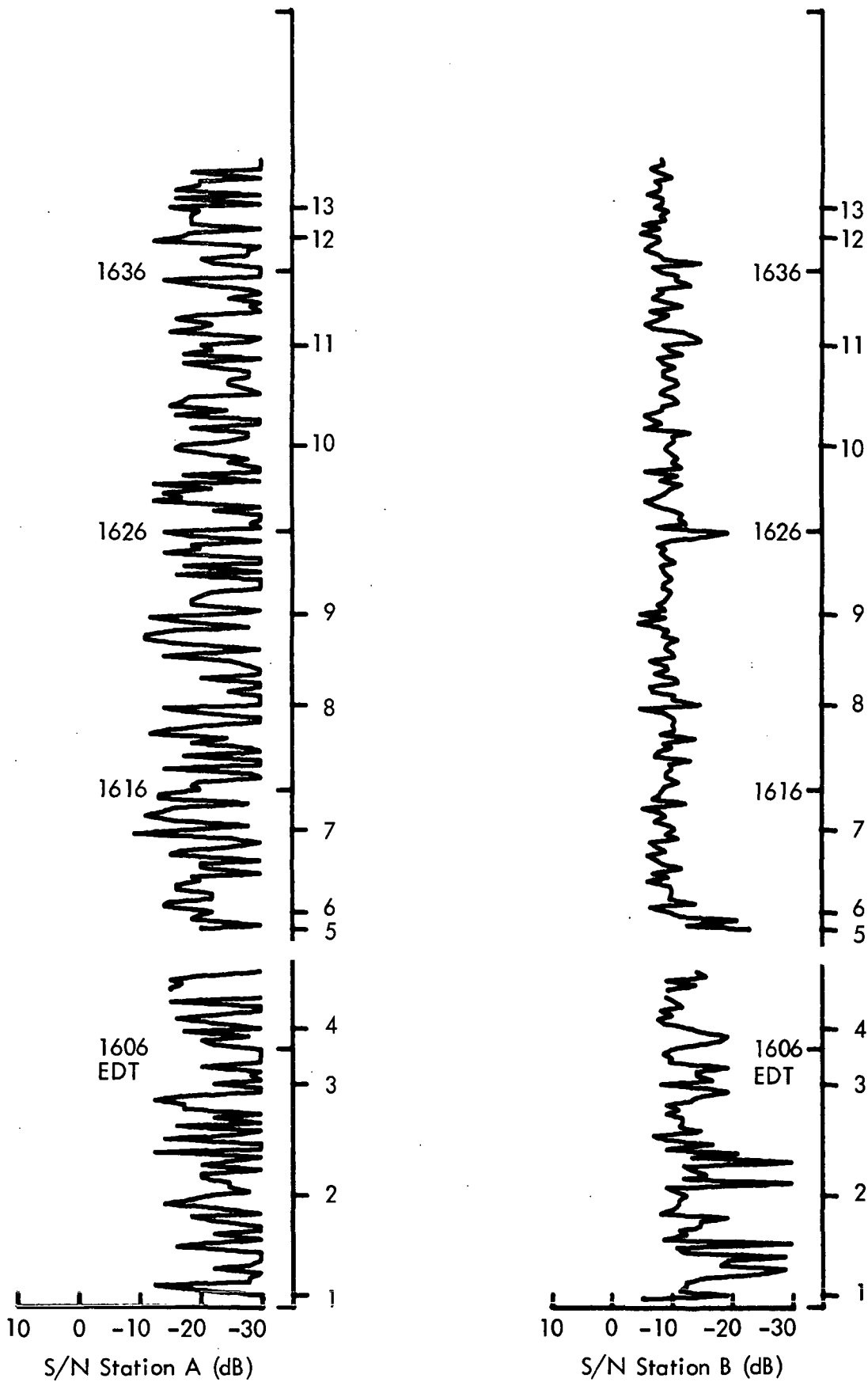

Figure A-67 . Flight I-23 (First 44 Min), S/N Station A and B;
 SWL VOR Cloverleaf, 3/8/75, 3300', 1556-1747 EDT, 1956-2147 GMT.

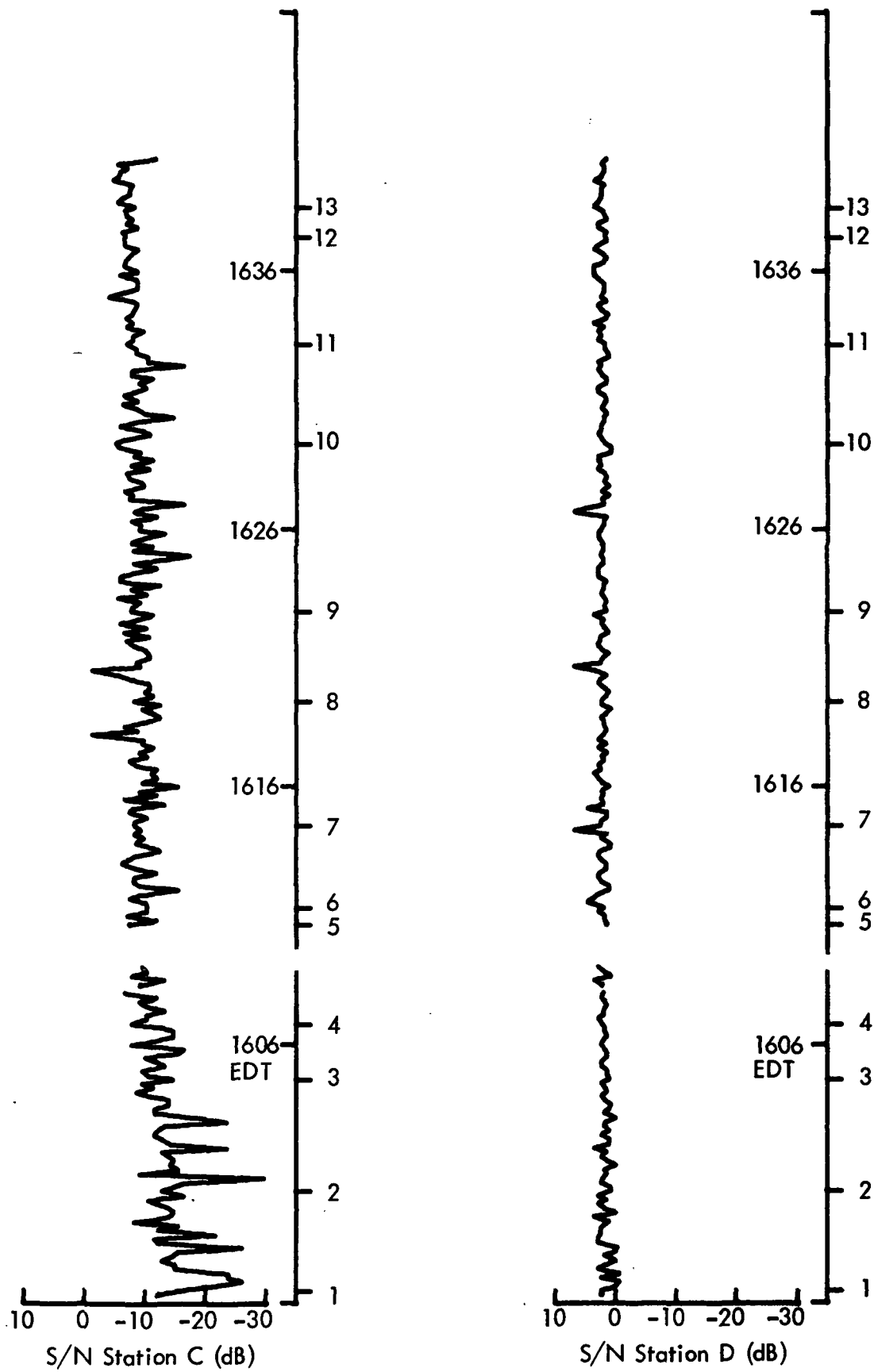

Figure A-68 . Flight 1-23 (First 44 Min), S/N Station C and D;
 SWL VOR Cloverleaf, 3/8/75, 3300', 1556-1747 EDT, 1956-2147 GMT.

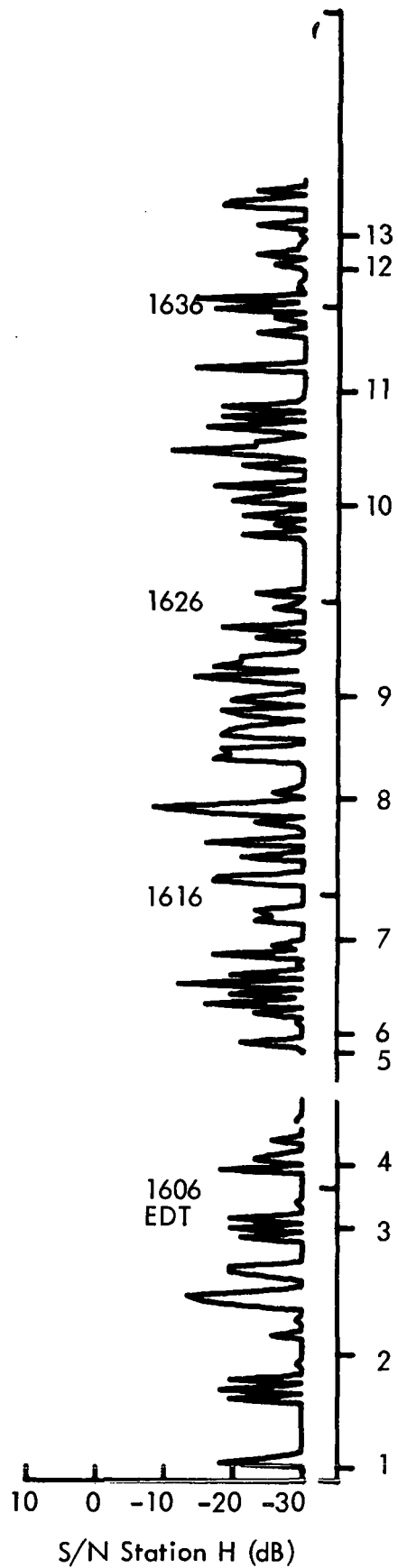

Figure A-69 . Flight 1-23 (First 44 Min), S/N Station H;
 SWL VOR Cloverleaf, 3/8/75, 3300', 1556-1747 EDT, 1956-2147 GMT.

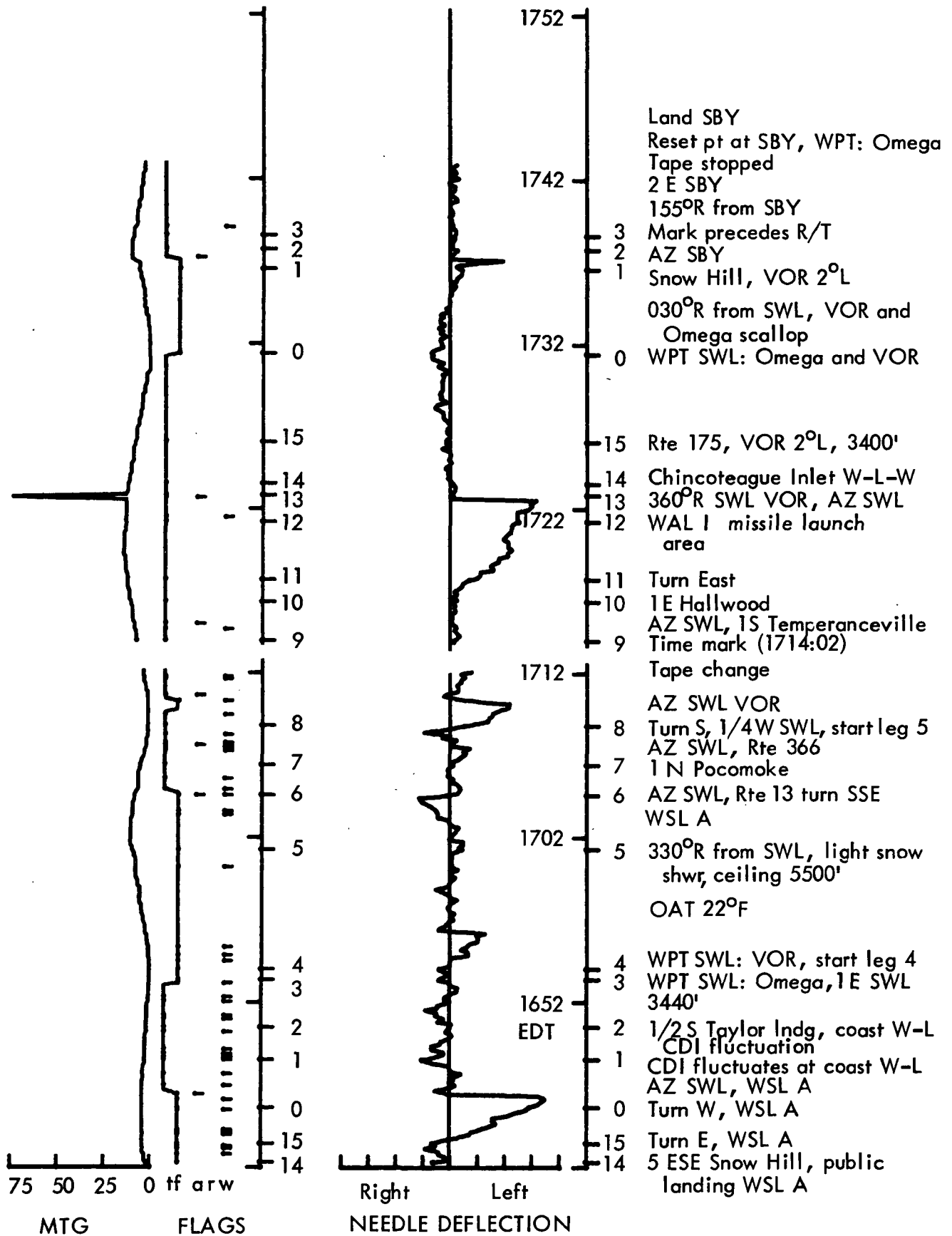

Figure A-70. Flight 1-23 (Second 61 Min), Miles to Go and Needle Deflection;
 SWL VOR Cloverleaf, 3/8/75, 3300', 1556-1747 EDT, 1956-2147 GMT.

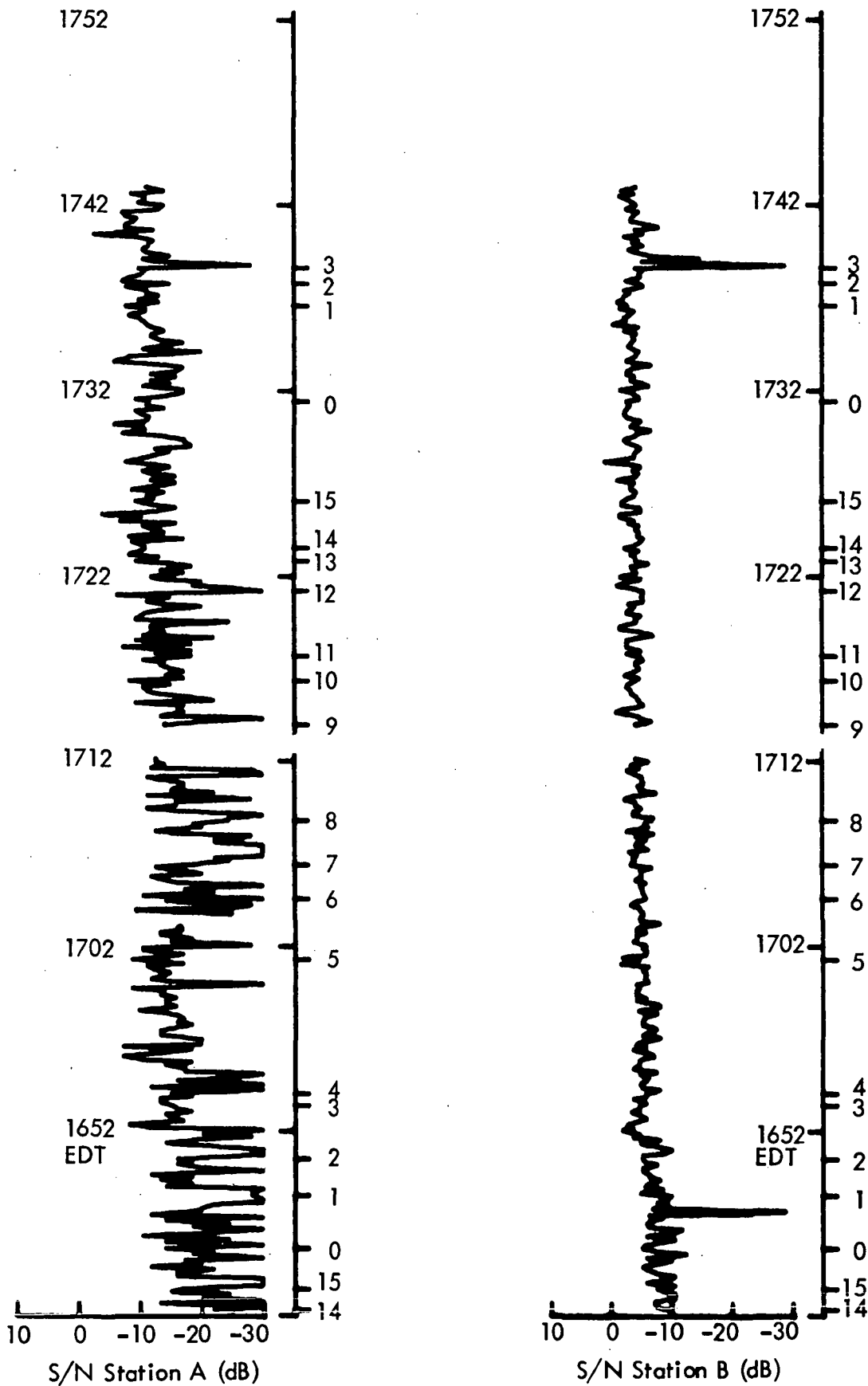

Figure A-71. Flight 1-23 (Second 61 Min), S/N Station A and B;
 SWL VOR Cloverleaf, 3/8/75, 3300', 1556-1747 EDT, 1956-2147 GMT.

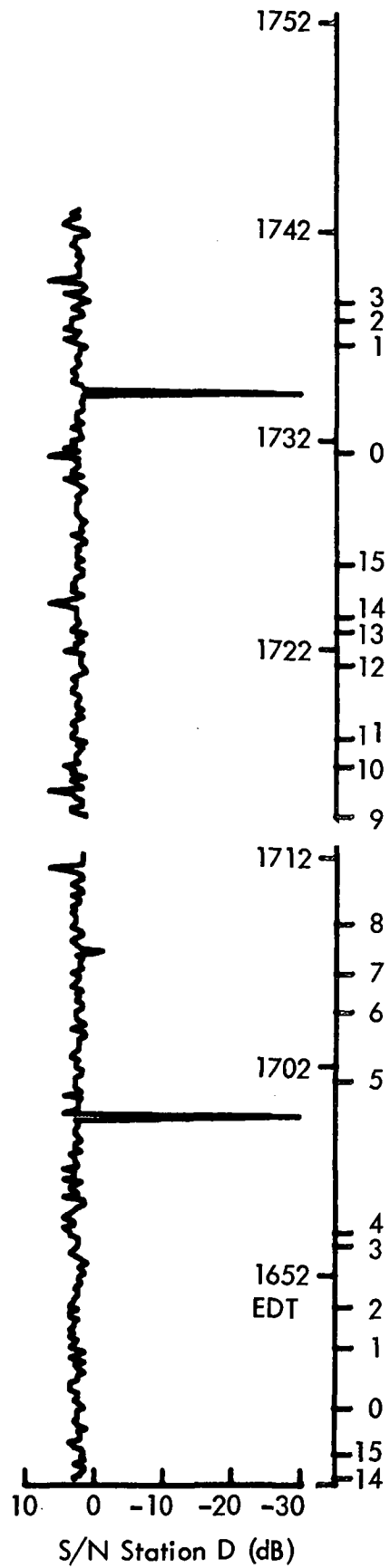
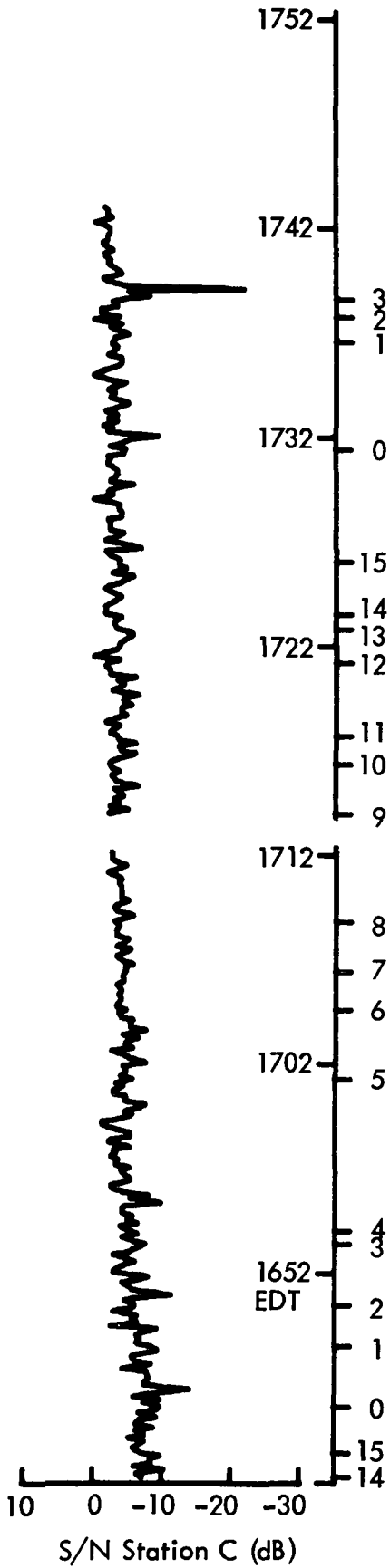

Figure A-72 . Flight 1-23 (Second 61 Min), S/N Station C and D;
SWL VOR Cloverleaf, 3/8/75, 3300', 1556-1747 EDT, 1956-2147 GMT.

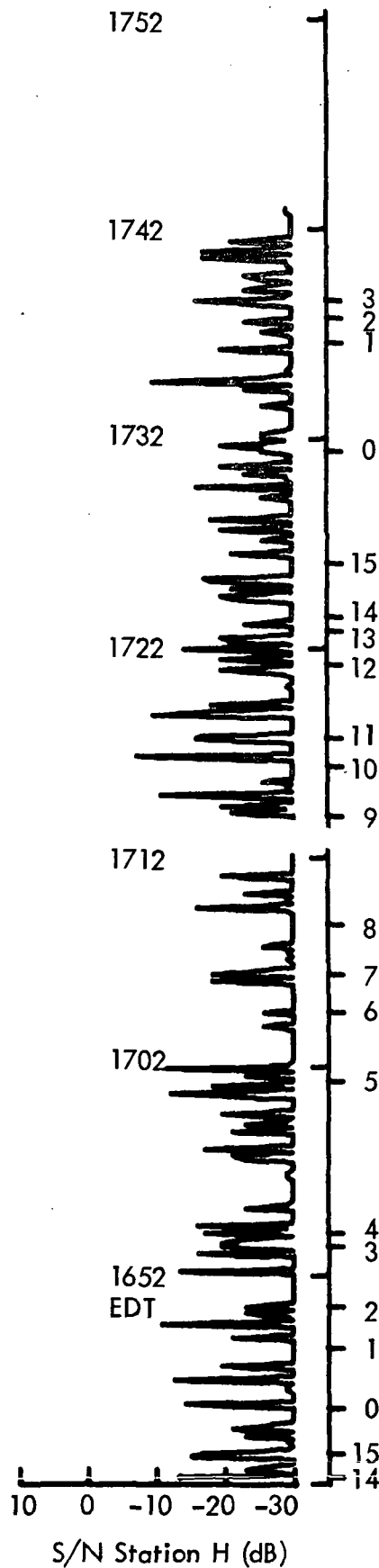

Figure A-73 . Flight 1-23 (Second 61 Min) S/N Station H;
 SWL VOR Cloverleaf, 3/8/75, 3300', 1556-1747 EDT, 1956-2147 GMT.

TEST DESCRIPTION

Flight No. 1-24

TEST OBJECTIVES: Obtain S/N data on non cardinal directions from SWL VOR, test coast effect, determine C-D LOP direction and size, try B-H LOP.

DATE: 3/9/75

DEPARTURE: SBY, 0956 EDT

DESTINATION: SBY

ROUTE: VOR cloverleaf (15° radial)

ALTITUDE: 3500'

WEATHER: VFR, 15 kts NW

SUMMARY: Cloverleaf repeat of flight 1-23. Flew constant C-D LOP east bound over coast, on west bound leg encountered deviation indication to left which was uncorrectable by maneuvering aircraft. Reset over SWL using A-B, B-D LOPs to begin ILS approach to SBY.

KEY WORDS: Coast, station pairs, LOP direction, interference, maneuvers.

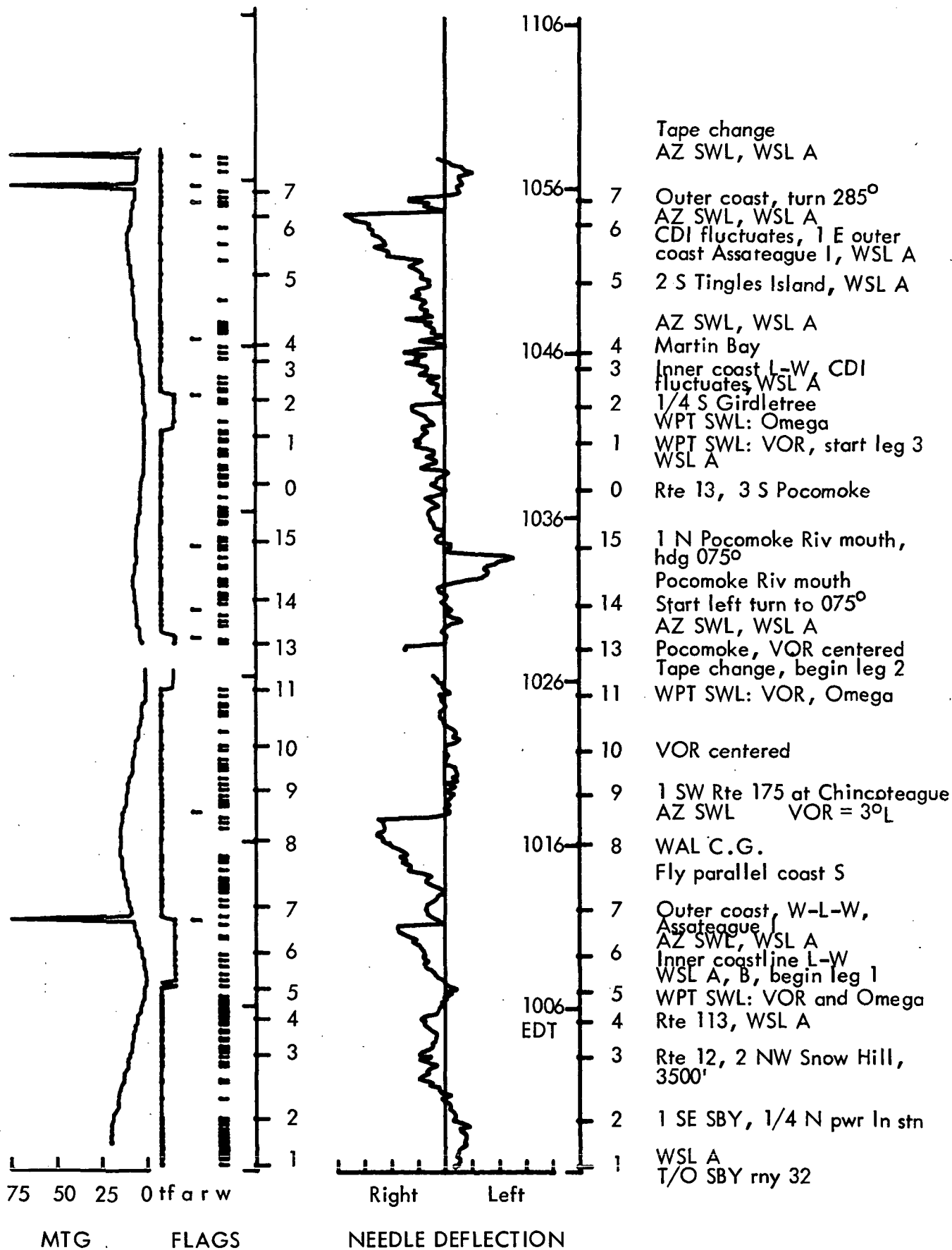

Figure A-74. Flight 1-24 (First 63 min), Miles to Go and Needle Deflection; SWL VOR Cloverleaf, 3/9/75, 3500', 0956-1245 EDT, 1356-1645 GMT.

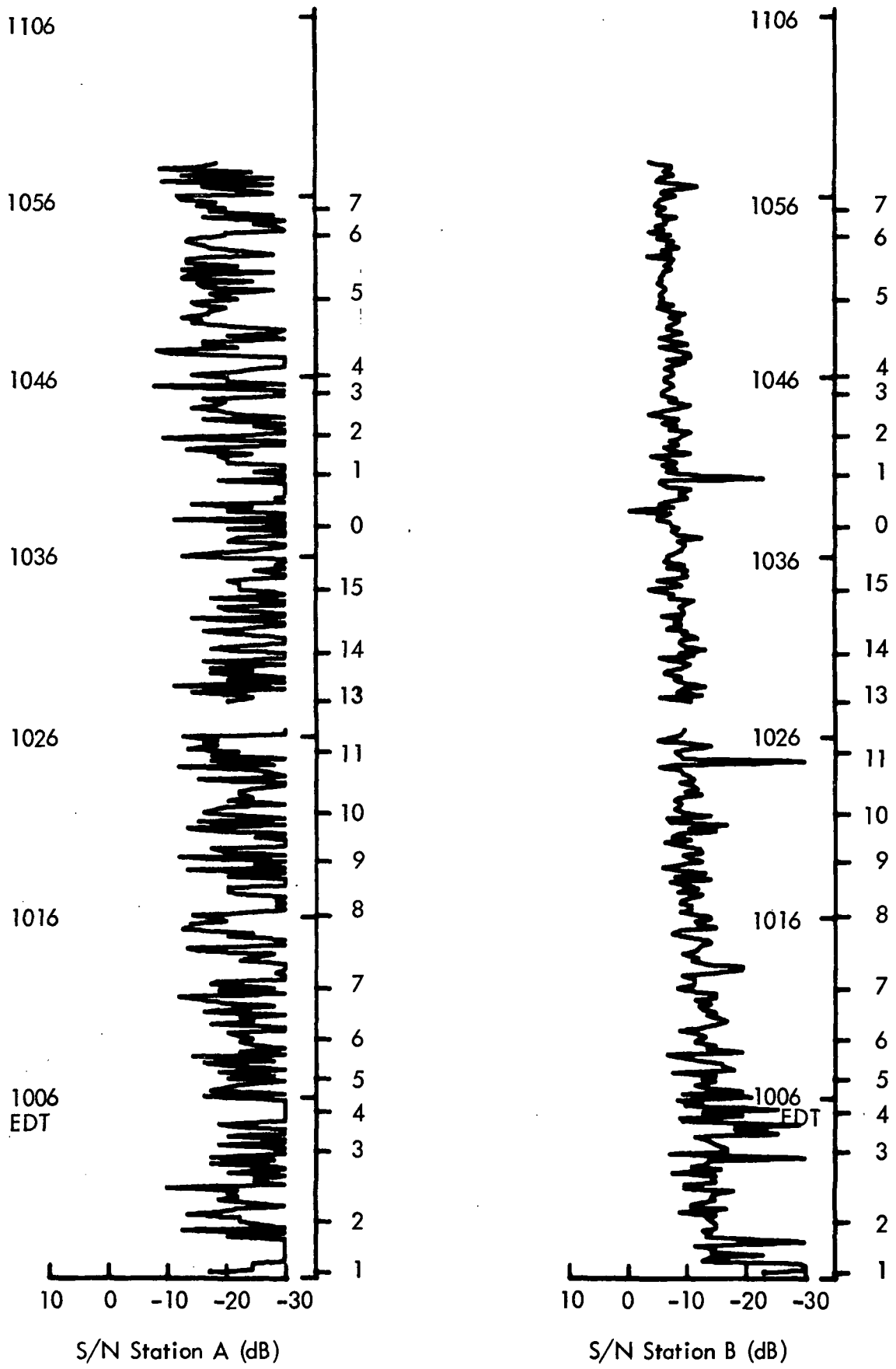

Figure A-75 . Flight 1-24 (First 63 min.), S/N Station A and B;
 SWL VOR Cloverleaf, 3/9/75, 3500', 0956-1245 EDT, 1356-1645 GMT.

1106

1056

1046

1036

1026

1016

1006 EDT

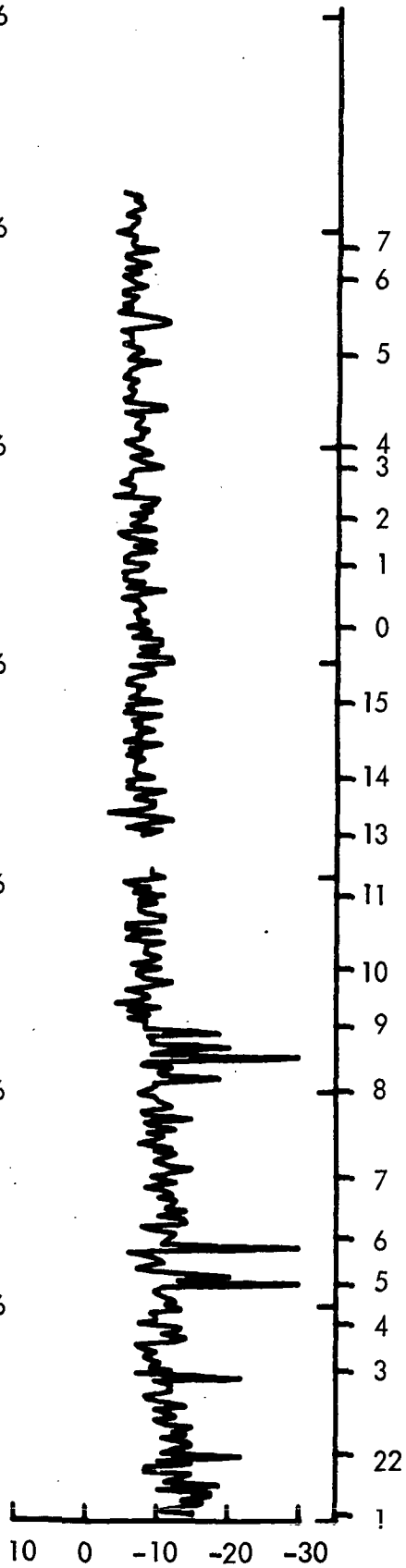

S/N Station C (dB)

1106

1056

1046

1036

1026

1016

1006 EDT

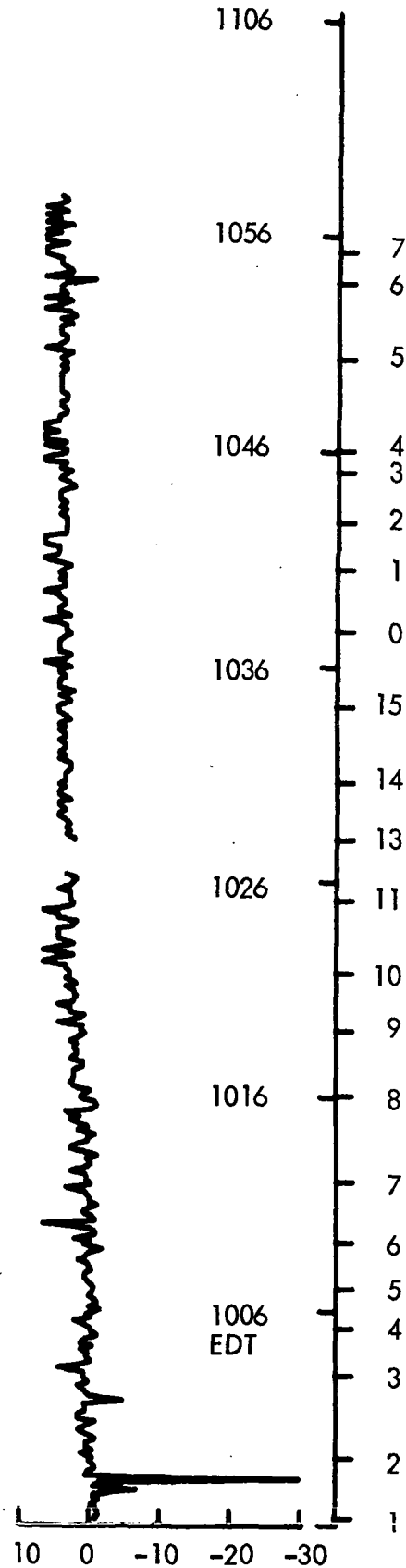

S/N Station D (dB)

Figure A-76. Flight 1-24 (First 63 min.), S/N Station C and D; SWL VOR Cloverleaf, 3/9/75, 3500', 0956-1245 EDT, 1356-1645 GMT.

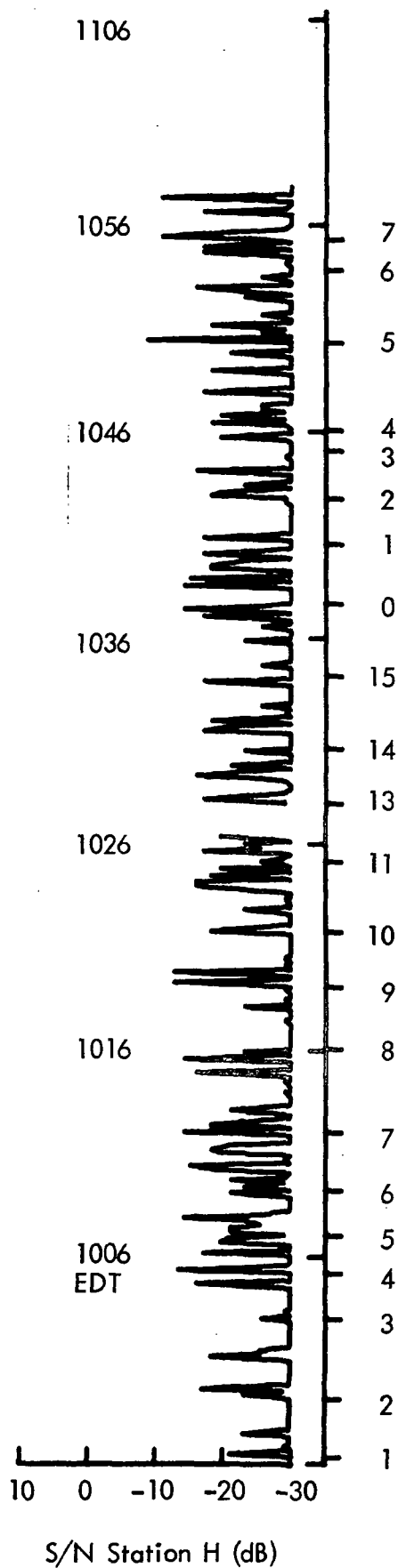

Figure A-77 . Flight 1-24 (First 63 min.), S/N Station H;
 SWL VOR Cloverleaf, 3/9/75, 3500', 0956-1245 EDT, 1356-1645 GMT.

A - 96

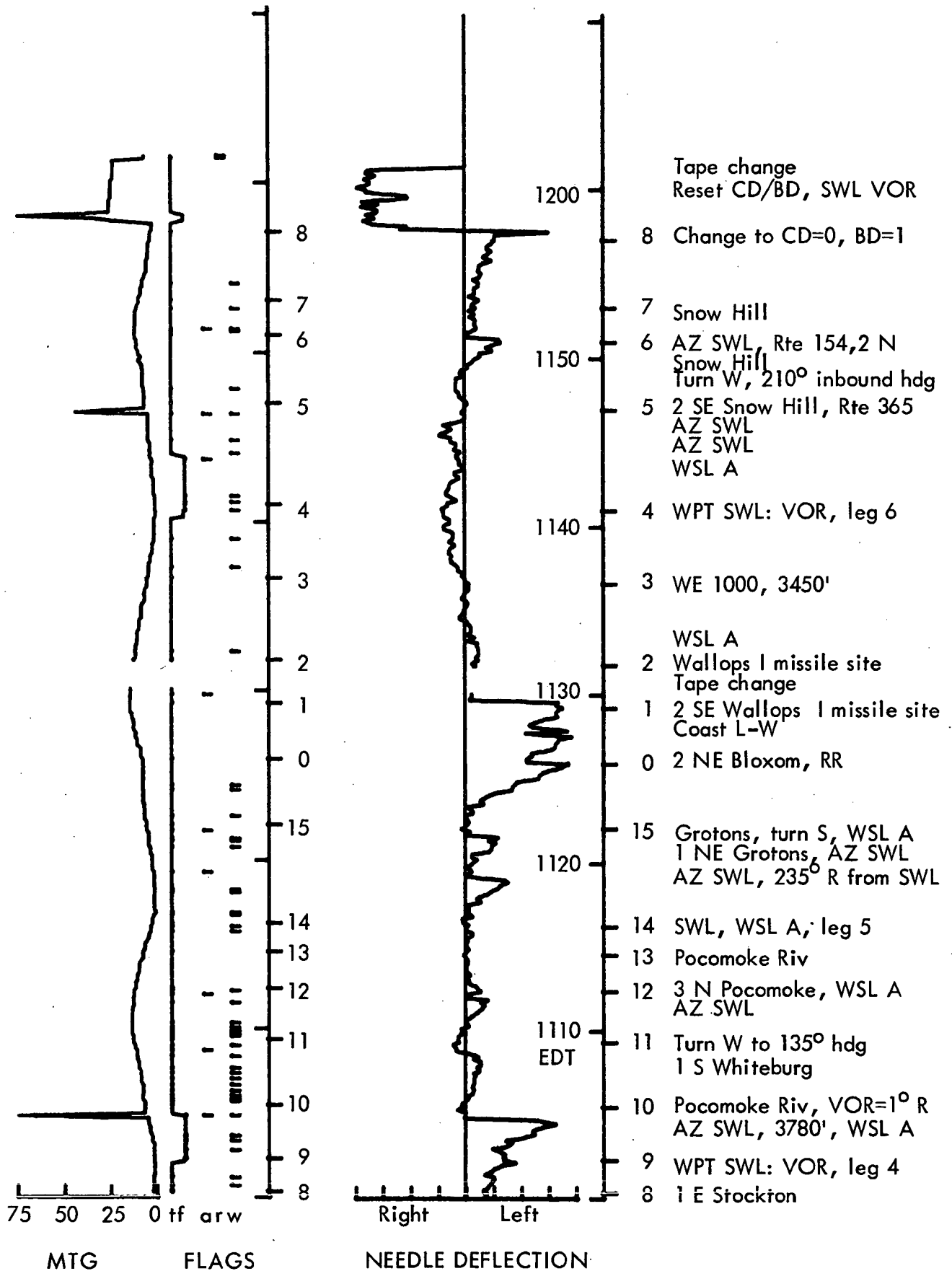

Figure A-78. Flight 1-24, (Second 62 min.), Miles to Go and Needle Deflection;
 SWL VOR Cloverleaf, 3/9/75, 3500', 0956-1245 EDT, 1356-1645 GMT.

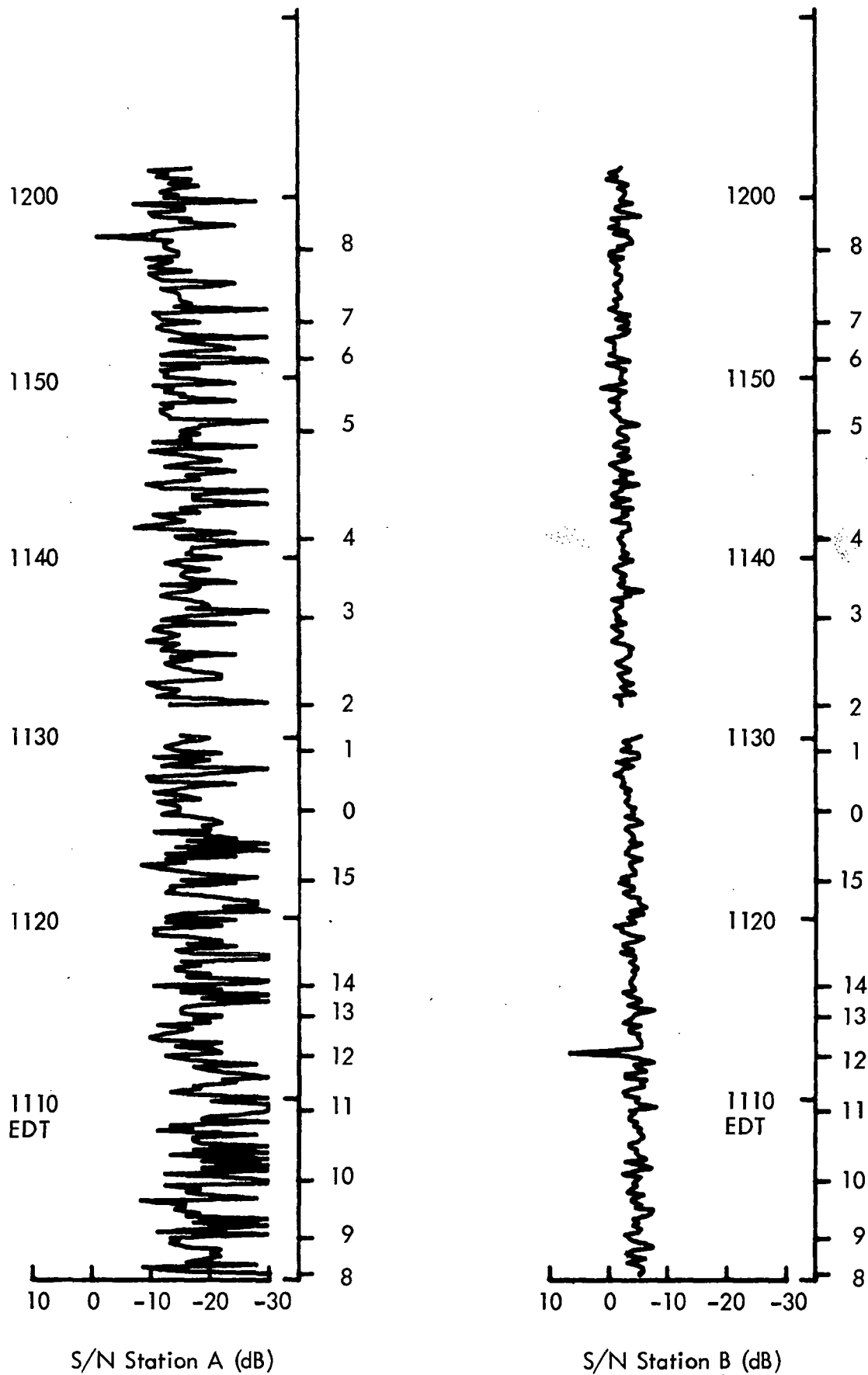
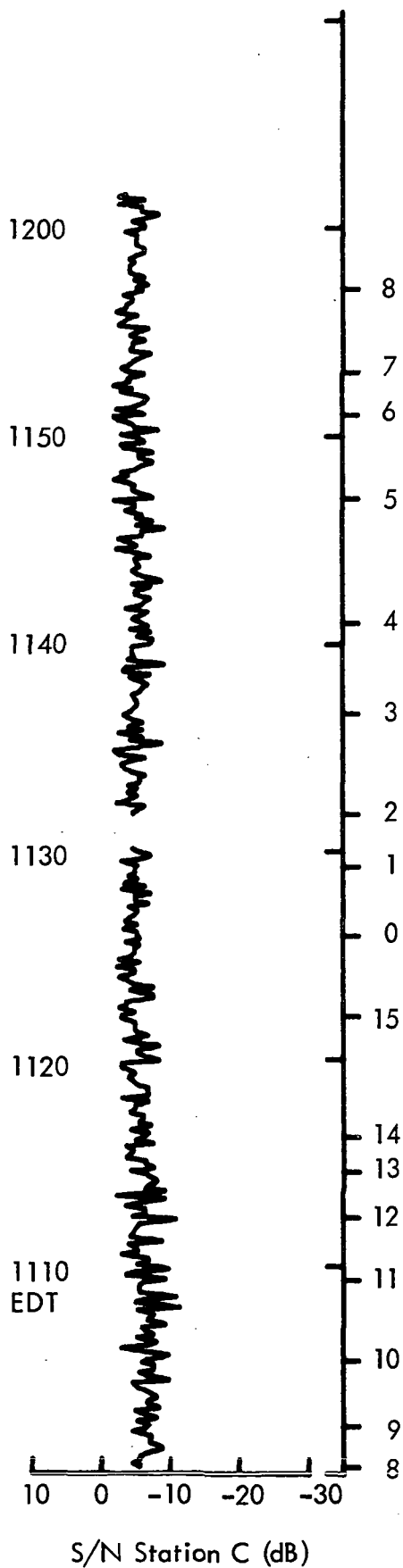
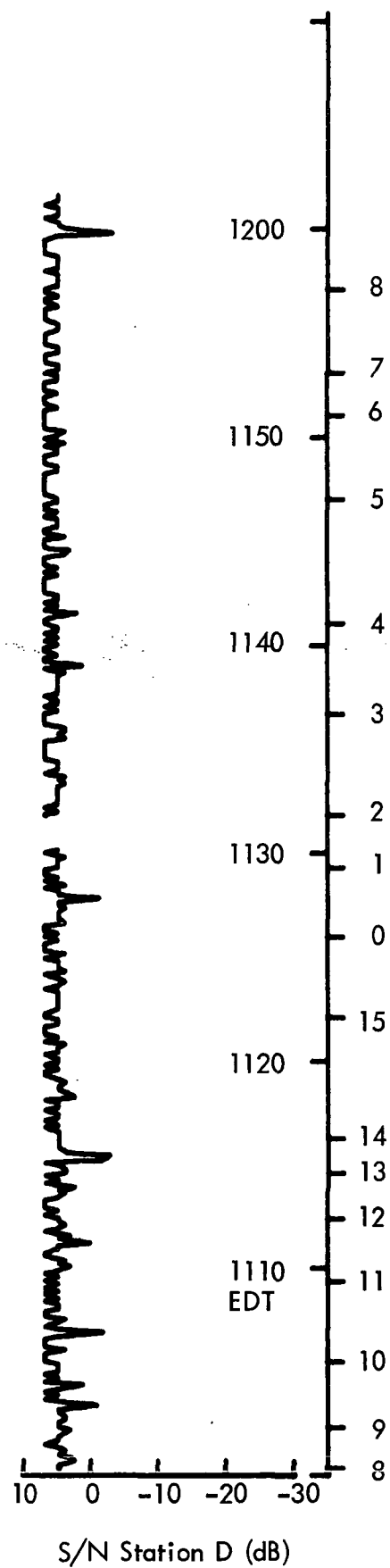

Figure A-79 . Flight 1-24, (Second 62 min.), S/N Station A and B;
 SWL VOR Cloverleaf, 3/9/75, 3500', 0956-1245 EDT, 1356-1645 GMT.



S/N Station C (dB)



S/N Station D (dB)

Figure A-80 . Flight 1-24, (Second 62 min.), S/N Station C and D;
 SWL VOR Cloverleaf, 3/9/75, 3500', 0956-1245 EDT, 1356-1645 GMT.

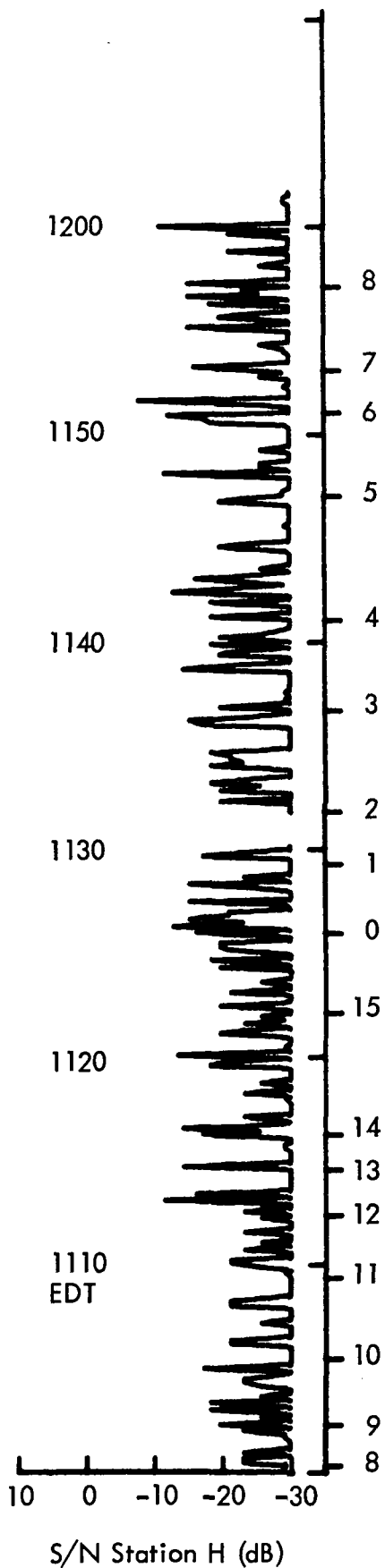

Figure A-81 . Flight 1-24, (Second 62 min.), S/N Station H;
 SWL VOR Cloverleaf, 3/9/75, 3500', 0956-1245 EDT, 1356-1645 GMT.

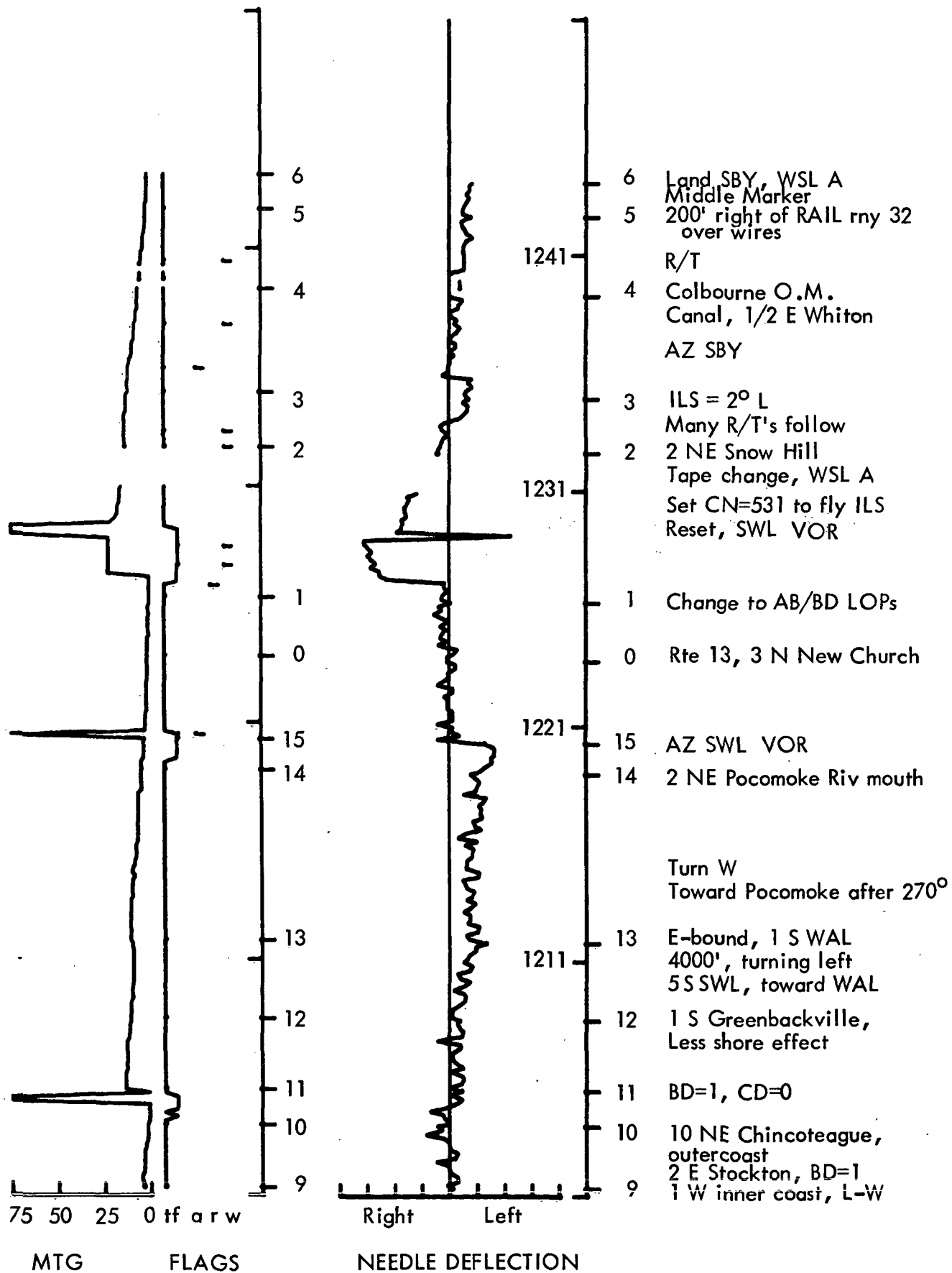

Figure A-82. Flight 1-24, (Third 44 min.), Miles to Go and Needle Deflection;
SWL VOR Cloverleaf, 3/9/75, 3500', 0956-1245 EDT, 1356-1645 GMT.

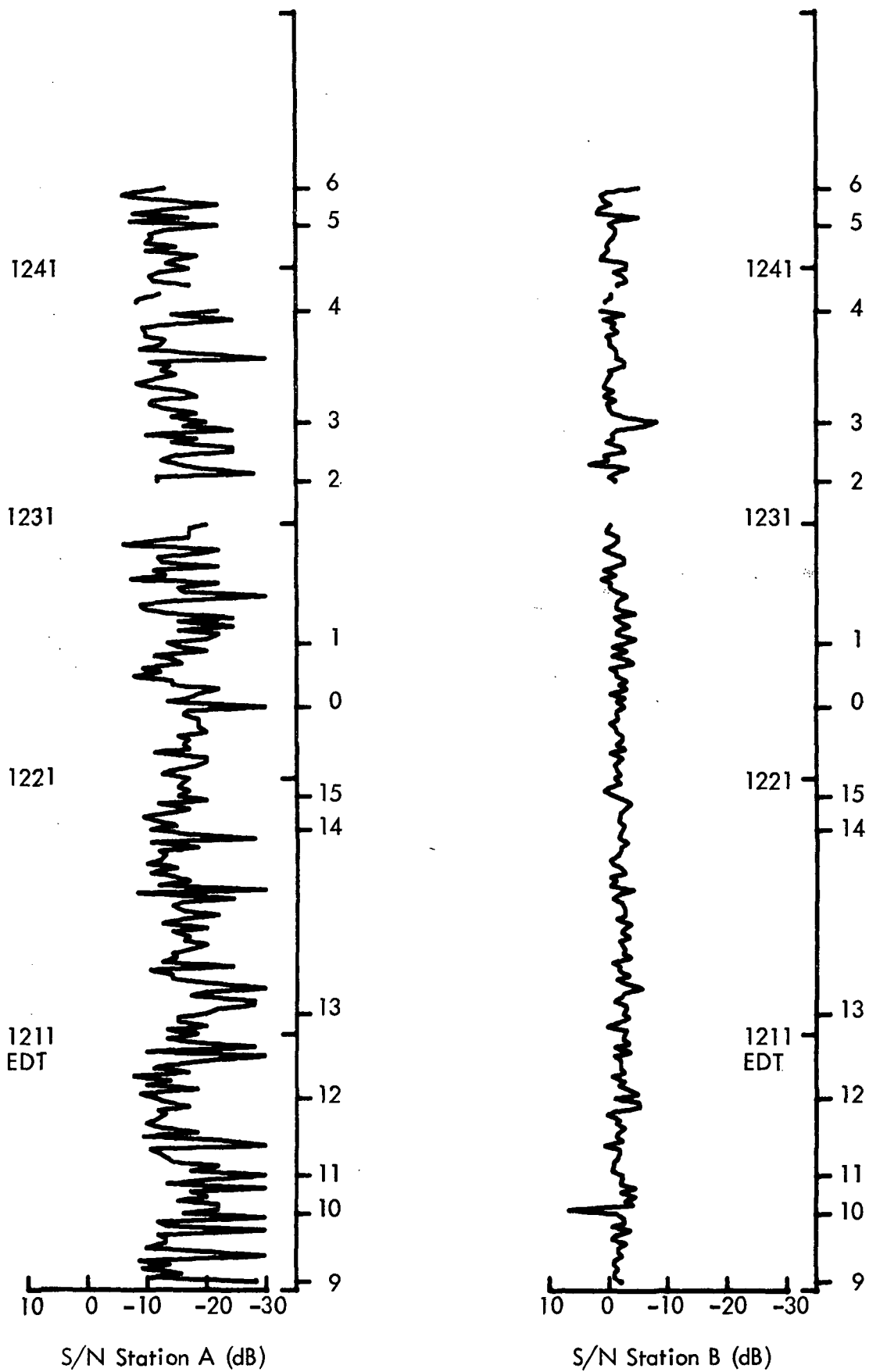
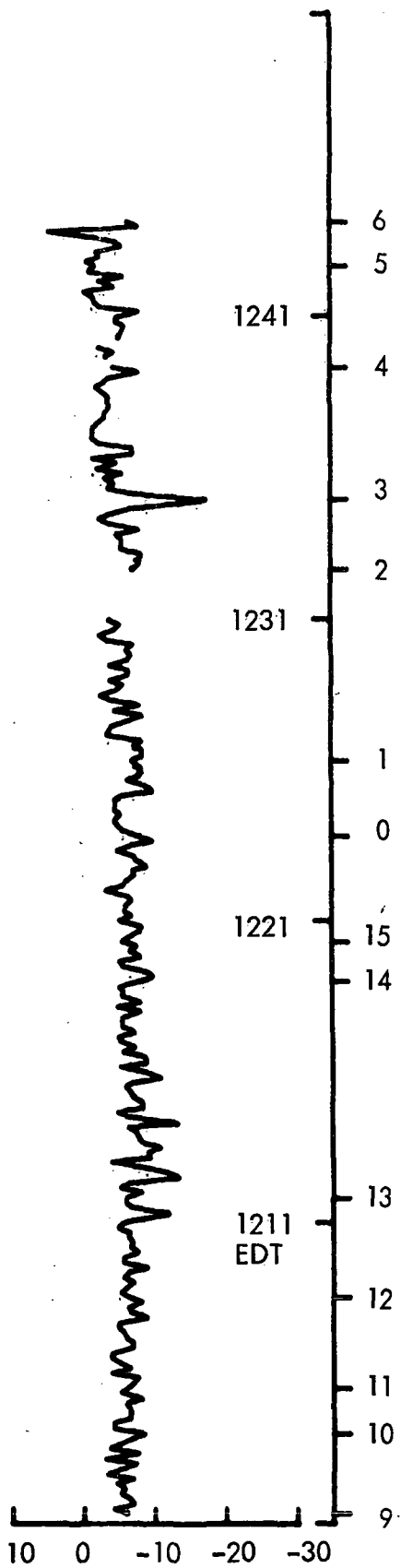
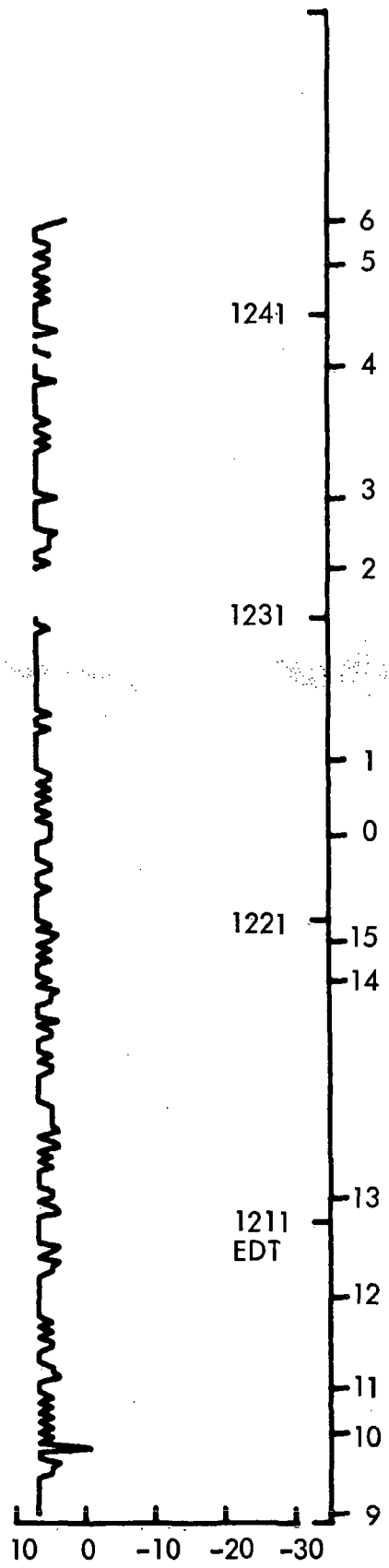

Figure A-83 . Flight 1-24,(Third 44 min.), S/N Station A and B;
 SWL VOR Cloverleaf, 3/9/75, 3500', 0956-1245 EDT, 1356-1645 GMT.



S/N Station C (dB)



S/N Station D (dB)

Figure A-84 . Flight 1-24, (Third 44 min.), S/N Station C and D;
SWL VOR Cloverleaf, 3/9/75, 3500', 0956-1245 EDT, 1356-1645 GMT.

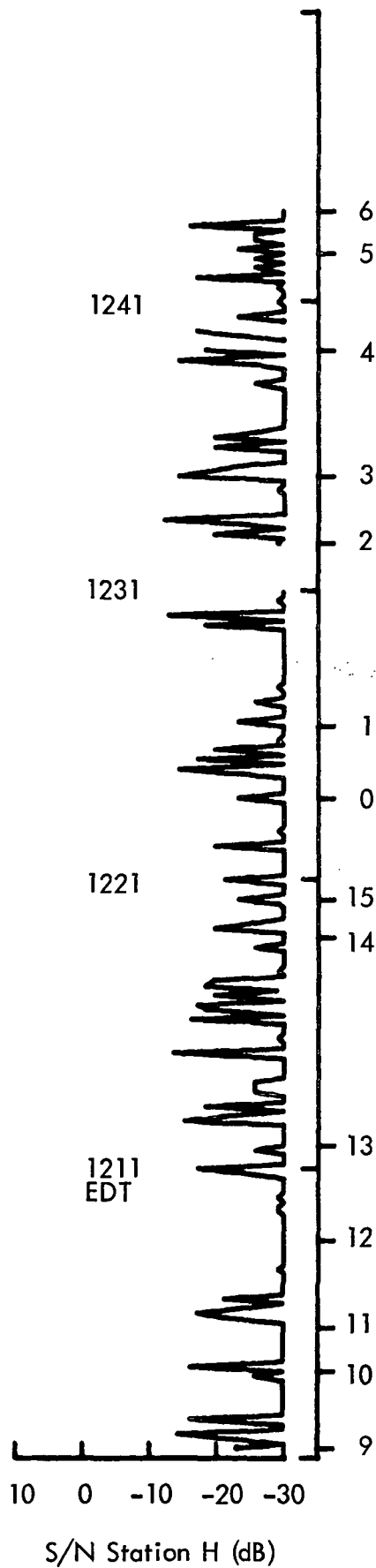

Figure A-85 . Flight 1-24, (Third 44 min.), S/N Station H;
 SWL VOR Cloverleaf, 3/9/75, 3500', 0956-1245 EDT, 1356-1645 GMT.

APPENDIX B

PLOTS OF NORTHEAST CORRIDOR FLIGHT DATA

APPENDIX B

PLOTS FOR NORTHEAST CORRIDOR FLIGHT DATA

B.1 EXPLANATION OF FLIGHT DATA PLOTS

Most flights have several sheets of documentation. Each flight has a flight test description sheet, and most flights have data from the flight consisting of an Omega indication sheet with miles to go readout, receiver status flags, and needle deflection; plus additional sheets containing S/N ratio plots for selected stations.

The flight test description sheet has four sections: flight objectives, pertinent information, summary, and key words. The flight objectives section describes the reasons for making the flight, i.e., what data was to be collected, and phenomena to be observed. The pertinent information section contains the date, departure point, route, altitude, destination, and weather. The summary is a paragraph description of the flight, describing operational procedures, effects observed, and quality of the data. Key words provide a quick reference for comparing the various anomalies observed on each flight.

The Omega indication sheet contains various parameters plotted against time. These parameters are the miles to go (MTG) readout, plotted on a scale of 0-75 miles, four status flags, and the needle deflection. The four status flags are readouts of the to/from flag, activation of the autozero command in the past 10 seconds, activation of the lane accumulator reset in the past ten seconds, and occurrence of a weak signal light showing insufficient S/N ratio on a station used for navigation in the past 10 seconds. The needle deflection is that deflection indicated to the pilot, sampled every 10 seconds and based on data accumulated at the end of an Omega transmission cycle. Operator discrete code changes are plotted along the vertical axis to mark the occurrence of various events in synchronization with the data. From these ticks a time reference was generated, and times are labeled every ten minutes. The title of the figure is at the bottom of the page, and it tells what part of each flight was processed to provide the plotted data. In addition, the parameters plotted, the origin, route, date, and altitude of the flight are given, along with the time of the plotted data in both local and Greenwich time.

Other plots are S/N ratios of various stations as estimated by the Omega receiver. The S/N plots, described in the text, derive time axis and operator discrete code information from the same data base as the MTG and needle deflection plots. Thus, comparison of the various plots is simplified because all have identical vertical time axes.

GLOSSARY

AGL	Above Ground Level (Altitude)	MTG	Miles To Go
Apt	Airport	NEC	Northeast Corridor
AZ	AutoZero	OAT	Outside Air Temperature
BED	Bedford Airport	OM	Outer Marker
CDI	Course Deviation Indicator	R	Radial
CN	Course Number	Riv	River
EDT	Eastern Daylight Time	RR	Railroad
EST	Eastern Standard Time	Rte	Route
GMT	Greenwich Mean Time	SENS	Signal Sensitivity Control on Receiver
I	Island	S/N	Signal to Noise
IFR	Instrument Flight Rules	str	Strong
ILS	Instrument Landing System	TAS	True Air Speed
Int	Airway Intersection	TCA	Terminal Control Area
LOP	Line of Position	VFR	Visual Flight Rules
L-W	Land to Water	VOR	Very High Frequency Omnidirectional Radio Range
min	Minute	wk	Weak
MM	Middle Marker	W-L	Water to Land
mod	Moderate	WSL	Weak Signal Light
MSL	Mean Sea Level (Altitude)	WPT	Waypoint

TEST DESCRIPTION

Flight No. 2-1

TEST OBJECTIVES: Initial check of Omega receiver operation; accuracy compared to visual and VOR references.

DATE: 11/22/74

DEPARTURE: BED, 1430 EST

DESTINATION: BED

ROUTE: BED-LWM-BED

ALTITUDE: 2400'

WEATHER: VFR, 10 kts E, gusting to 20 kts

SUMMARY: Initial flight indicated the necessity for hard mounting the receiver, indicator and antenna coupler to provide the required chassis ground to receive usable signals. No recorded data since flight preceded installation of CIU.

KEY WORDS: Altitude effects, Maneuver effects.

TEST DESCRIPTION

Flight No. 2-2

TEST OBJECTIVES: Provide initial information concerning the operation of the test equipment along the Northeast Corridor.

DATE: 11/23/74 DEPARTURE: BED, 0950 EST
DESTINATION: FRG ROUTE: Zulu-2 with divert to FRG
ALTITUDE: 2000', 500' under WEATHER: VFR, 15 kts SW
NY TCA
SUMMARY: Some waypoints along the Hudson River were incorrectly computed,
but otherwise half mile accuracies were consistently achieved.
Only recorded data was strip chart recording of CDI presentation.

KEY WORDS: Suitability, altitude effects, terrain effects.

TEST DESCRIPTION

Flight No. 2-3

TEST OBJECTIVES: Initial flight employing interface hardware. Check point to point accuracy.

DATE: 12/3/74

DEPARTURE: FRG, 1233 EST

DESTINATION: BED

ROUTE: FRG-Mattituck, Mattituck-BED

ALTITUDE: 2000'

WEATHER: VFR in haze, 10 kts W

SUMMARY: Weak signals precluded successful navigation. Station A phase lock was lost several times on both legs of flight. Flight continued through local sunset, although data tape was stopped.

KEY WORDS: Suitability, terrain effects.

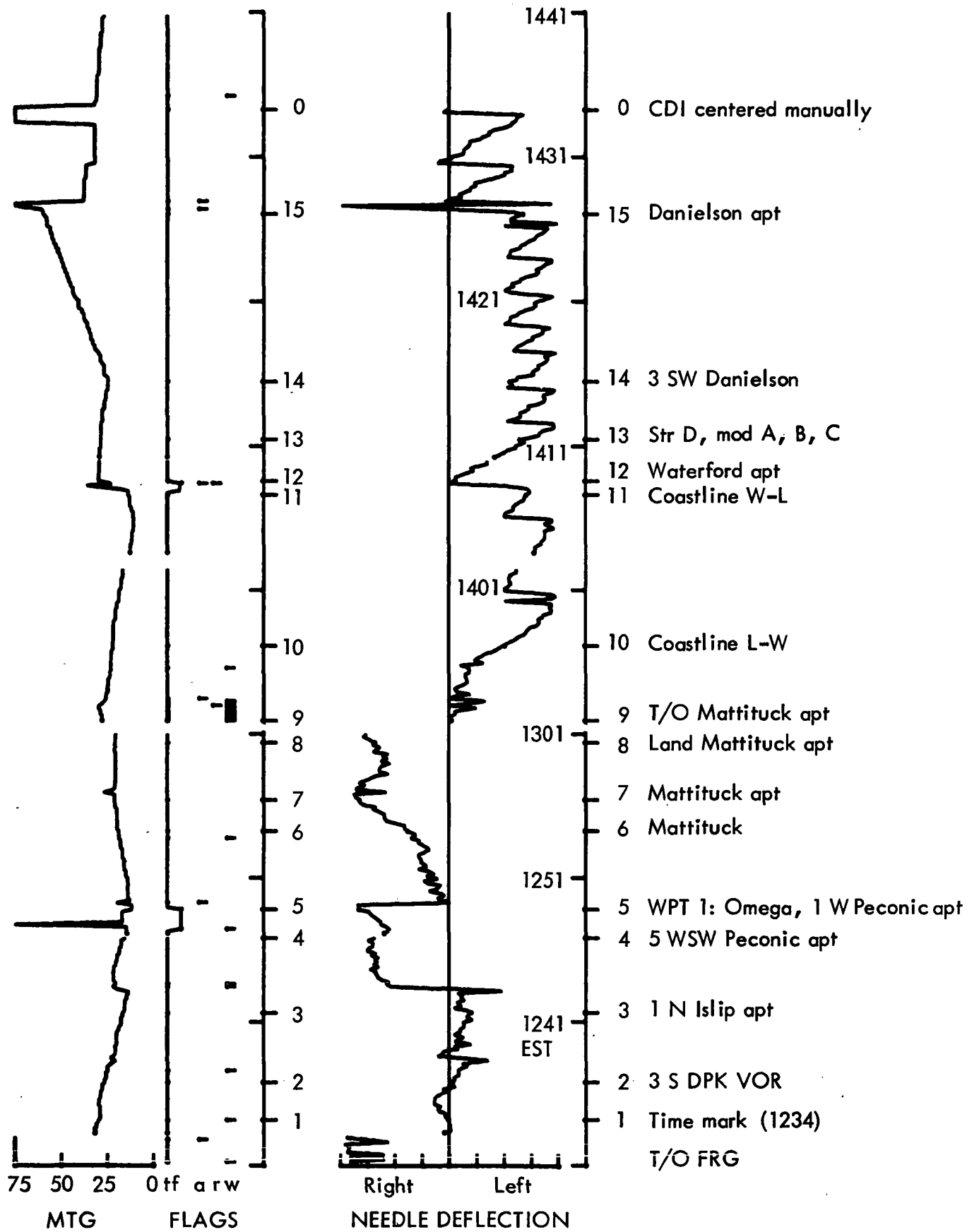

Figure B-1 . Flight 2-3, Miles to Go and Needle Deflection;
FRG-Mattituck-BED, 12/3/74, 2000', 1231-1442 EST, 1731-1942 GMT.

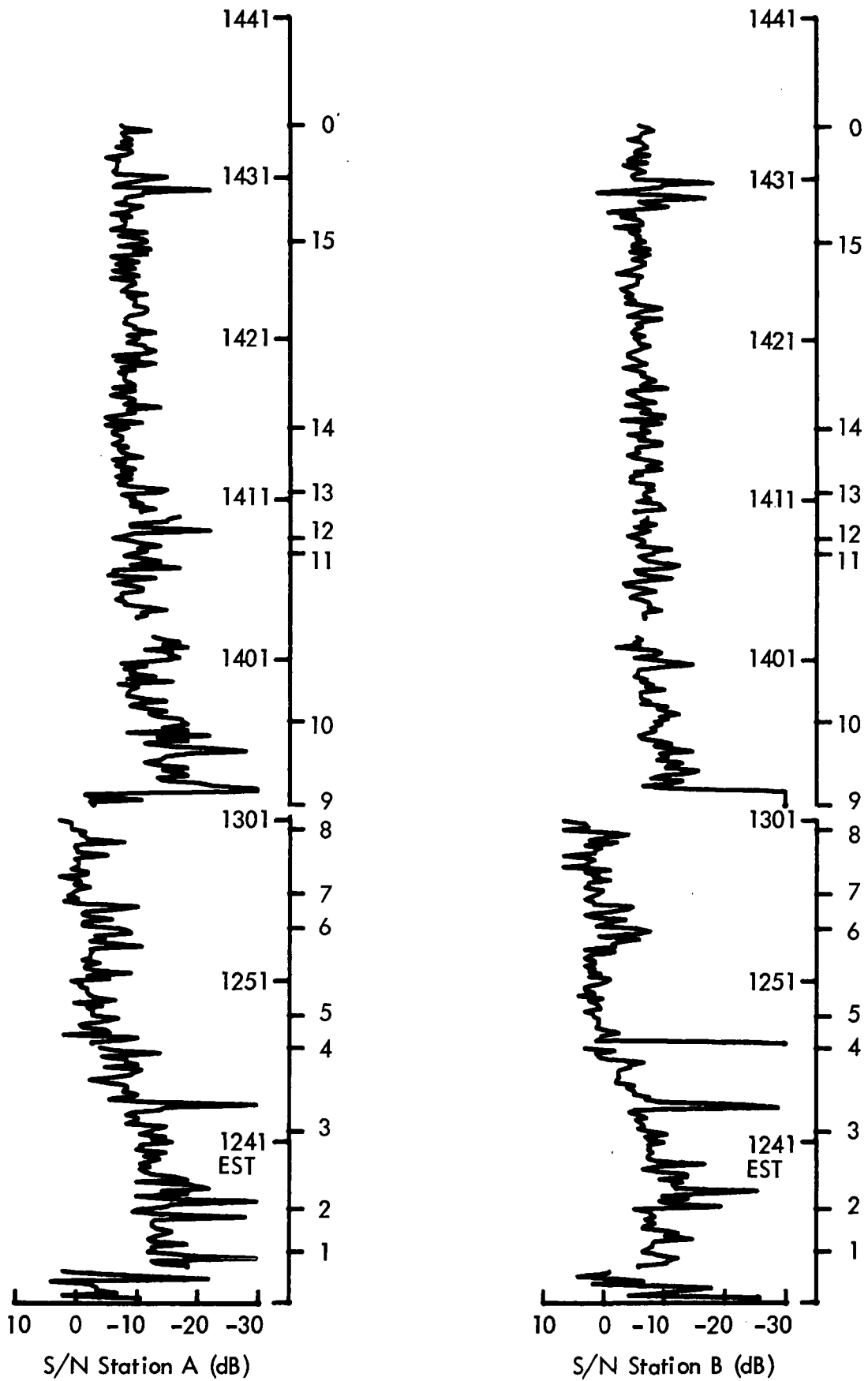

Figure B-2 . Flight 2-3, S/N Station A and B;
FRG-Mattituck-BED, 12/3/74, 2000', 1231-1442 EST, 1731-1942 GMT.

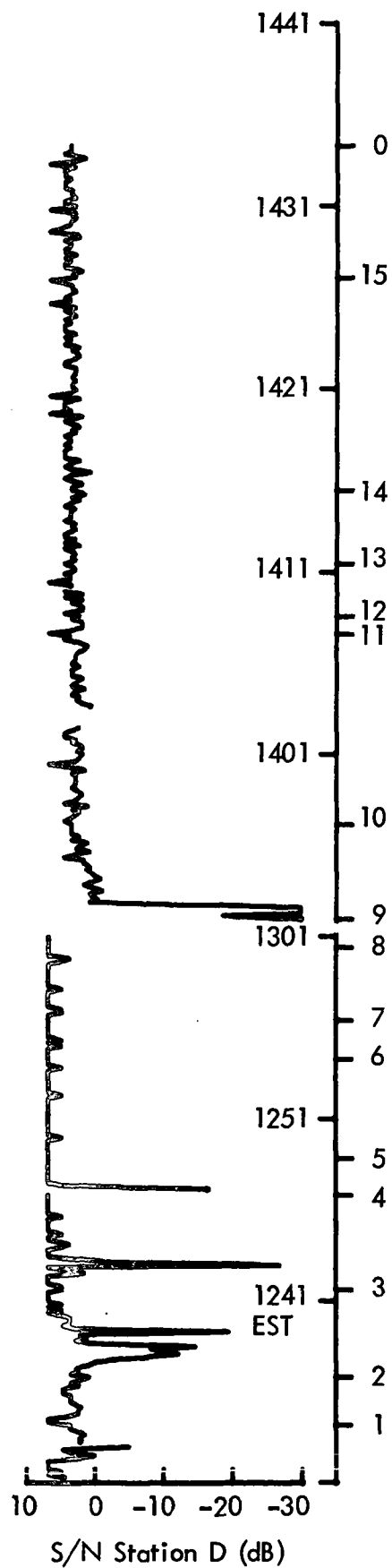
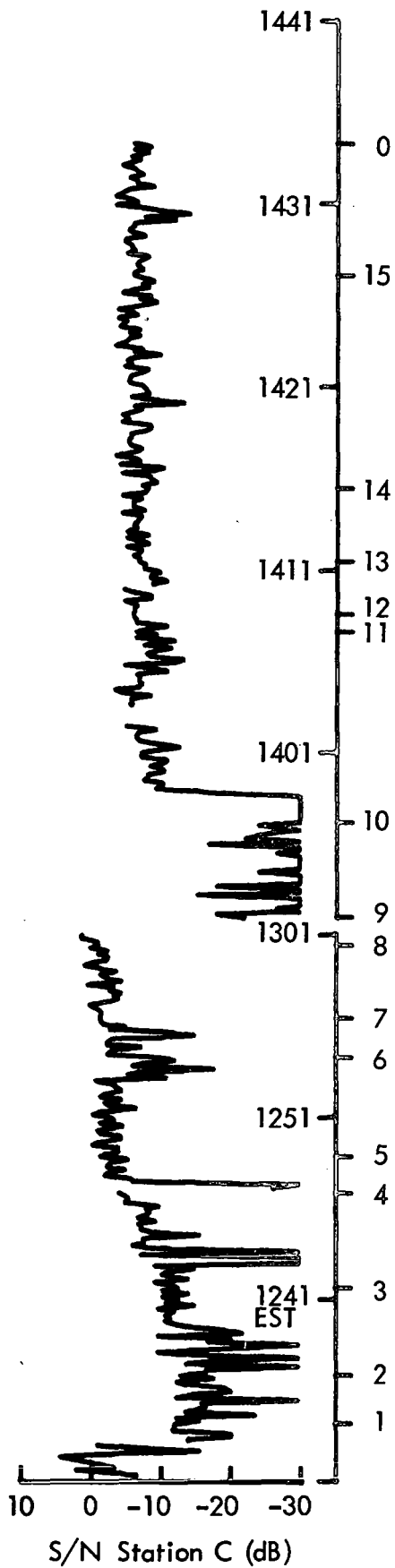

Figure B-3 . Flight 2-3, S/N Station C and D;
FRG-Mattituck-BED, 12/3/74, 2000', 1231-1442 EST, 1731-1942 GMT.

TEST DESCRIPTION

Flight No. 2-Z1-1

TEST OBJECTIVES: Provide additional low altitude data in the Northeast corridor and check CIU operation after modification to mate the CIU with the Wang. Measure diurnal effect magnitude.

DATE: 12/20/74

DEPARTURE: FRG, 1530 EST

DESTINATION: BED

ROUTE: Zulu-1 from FRG

ALTITUDE: 5500'

WEATHER: VFR, 18 kts NW

SUMMARY: Waypoints set in with +BD LOP changes were inaccurate due to failed sign chip on LOP 2. Accuracy was within one mile with -BD LOP waypoints. Some coast effect was noted near Griswold Airport.

KEY WORDS: Suitability, terrain effects.

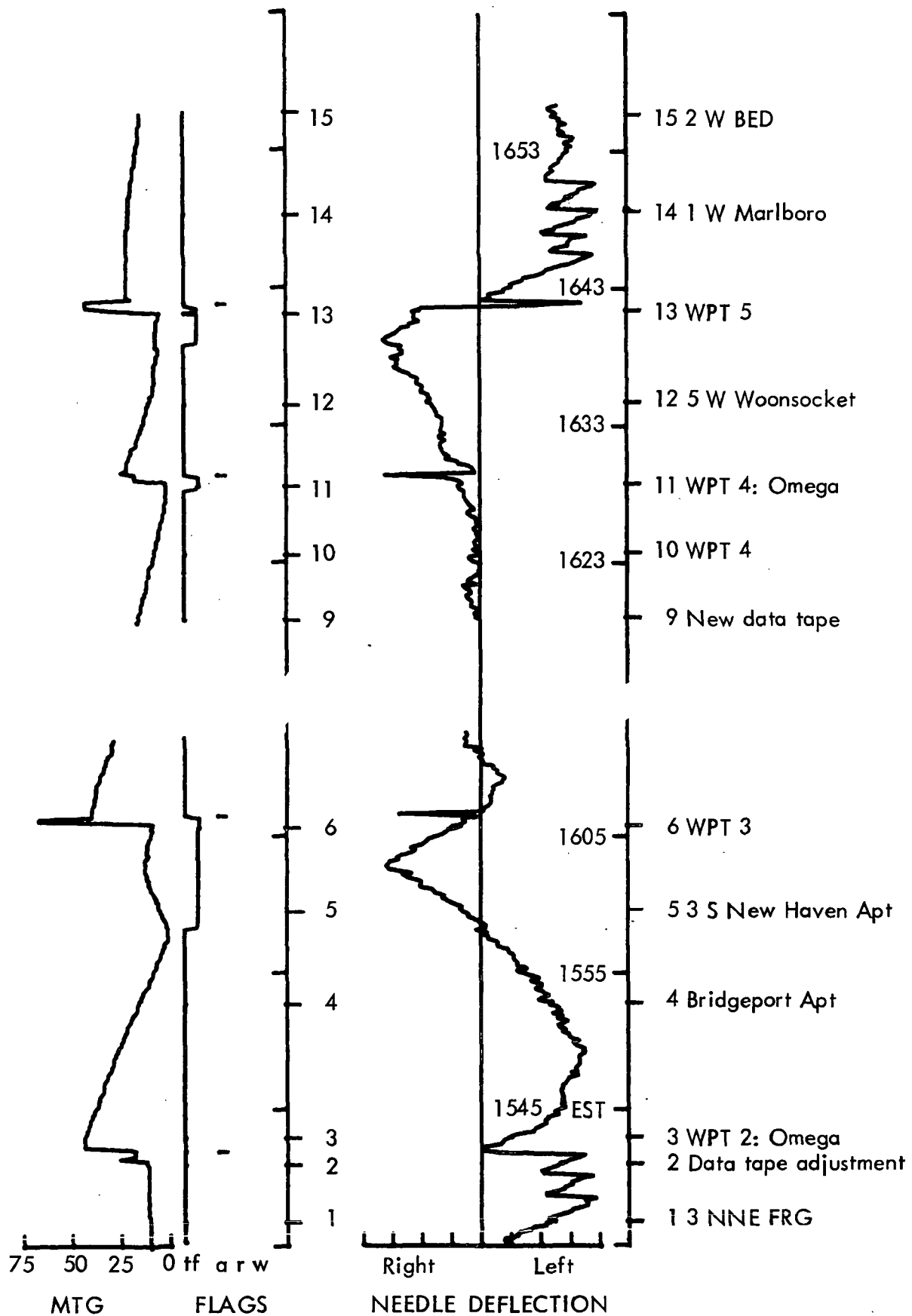

Figure B-4 . Flight 2-Z1-1, Miles to Go and Needle Deflection;
FRG-BED, 12/20/74, 5500', 1530-1700 EST, 2030-2200 GMT.

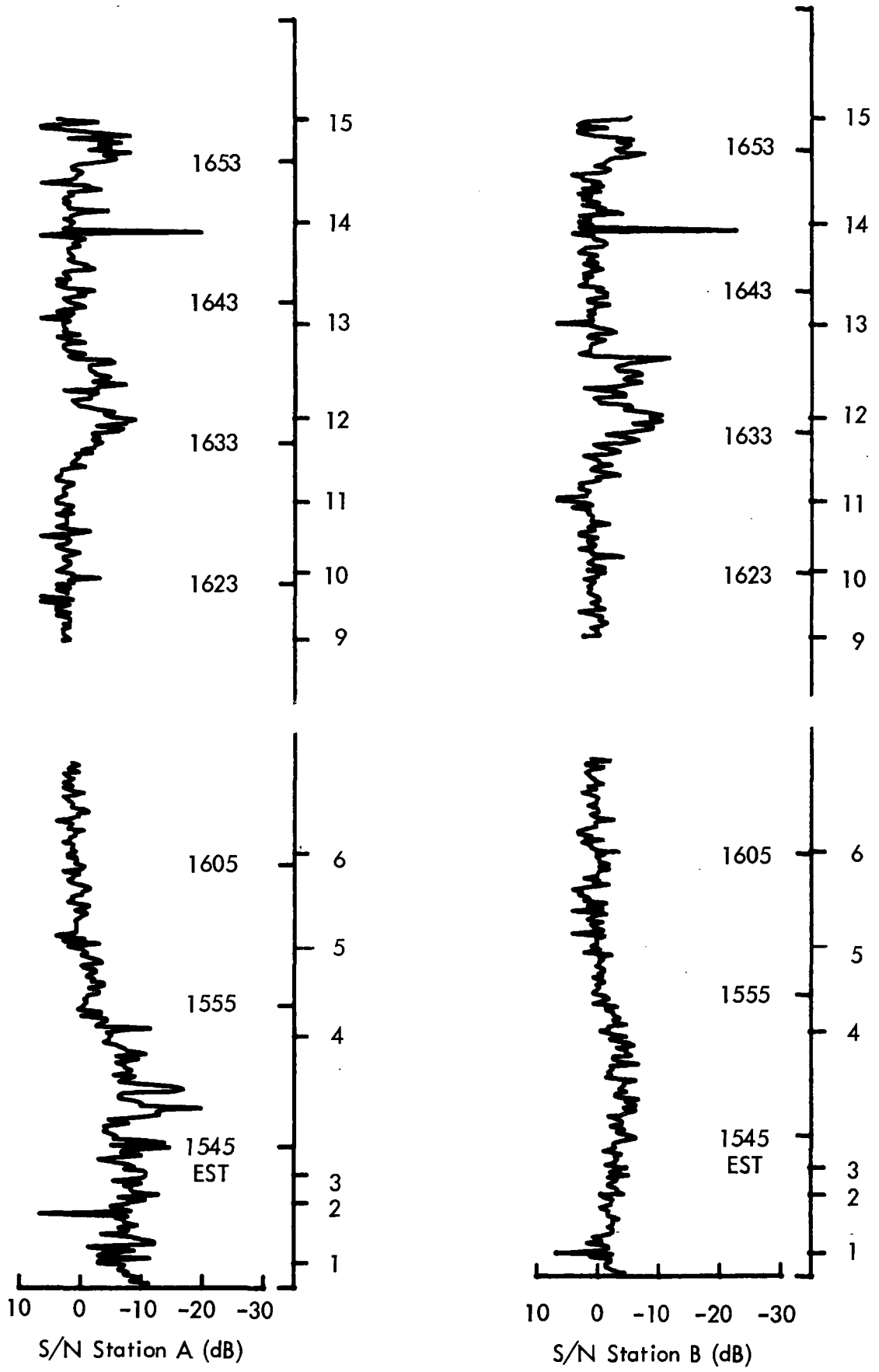

Figure B-5. Flight 2-Z1-1, S/N Station A and B;
 FRG-BED, 12/20/74, 5500', 1530-1700 EST, 2030-2200 GMT.

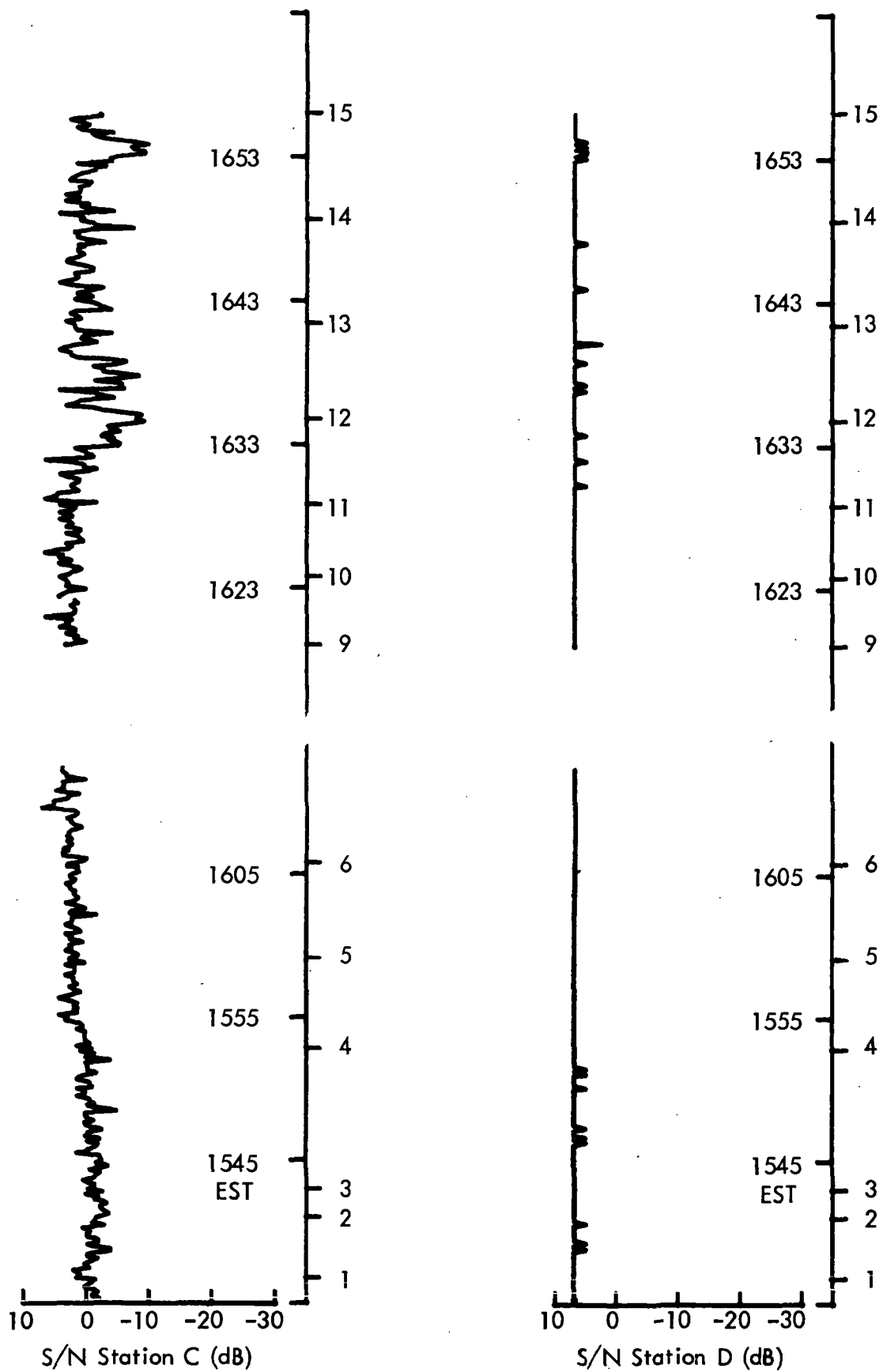

Figure B-6 . Flight 2-Z1-1, S/N Station C and D;
 FRG-BED, 12/20/74, 5500', 1530-1700 EST, 2030-2200 GMT.

TEST DESCRIPTION

Flight No. 2-Z1-2

TEST OBJECTIVES: Shakedown system after repairs to receiver, indicator and interface unit. Collect additional low altitude data. First flight with receiver and indicator hard mounted and antenna cable repaired.

DATE: 1/24/75

DEPARTURE: FRG, 1556 EST

DESTINATION: BED

ROUTE: Zulu 1

ALTITUDE: 3500'

WEATHER: VFR in haze, 20 kts WSW

SUMMARY: Receiver functioned satisfactorily after radios turned off. Encountered difficulty with +BD LOP waypoints due to undetected failed chip.

KEY WORDS: Suitability, altitude effects, terrain effects.

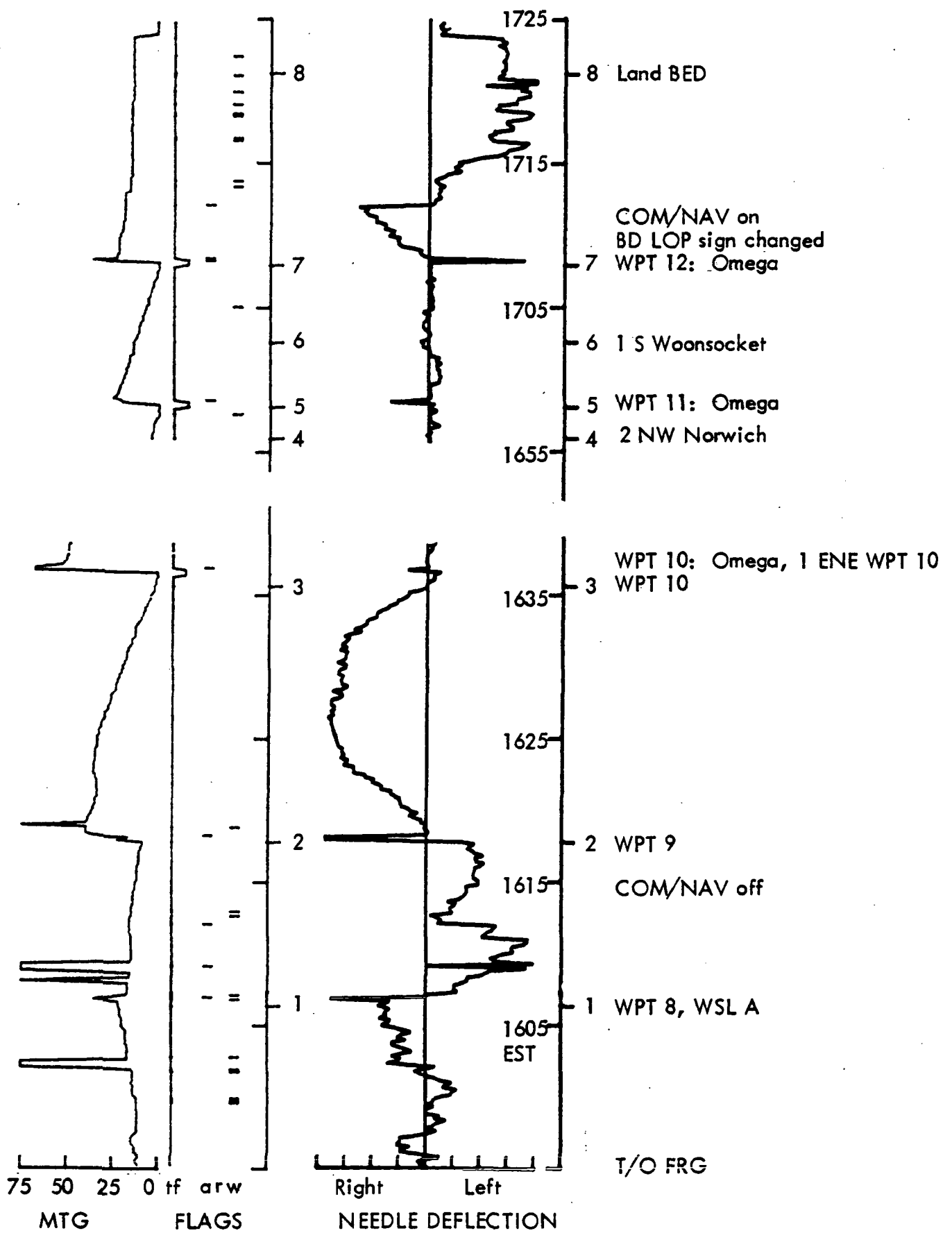

Figure B-7 . Flight 2-Z1-2, Miles to Go and Needle Deflection;
FRG-BED, 1/24/75, 3500', 1556-1720 EST, 2056-2220 GMT.

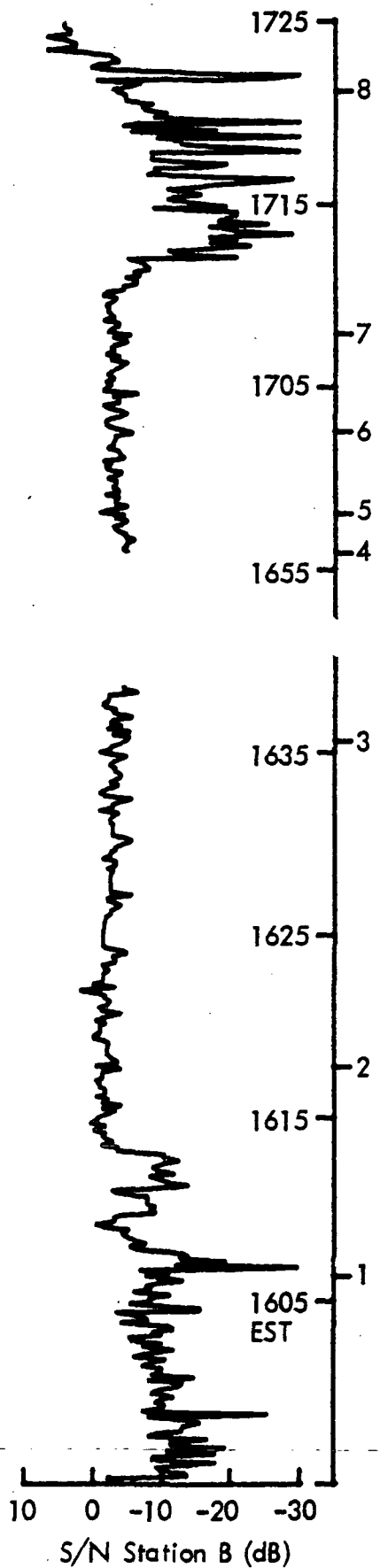
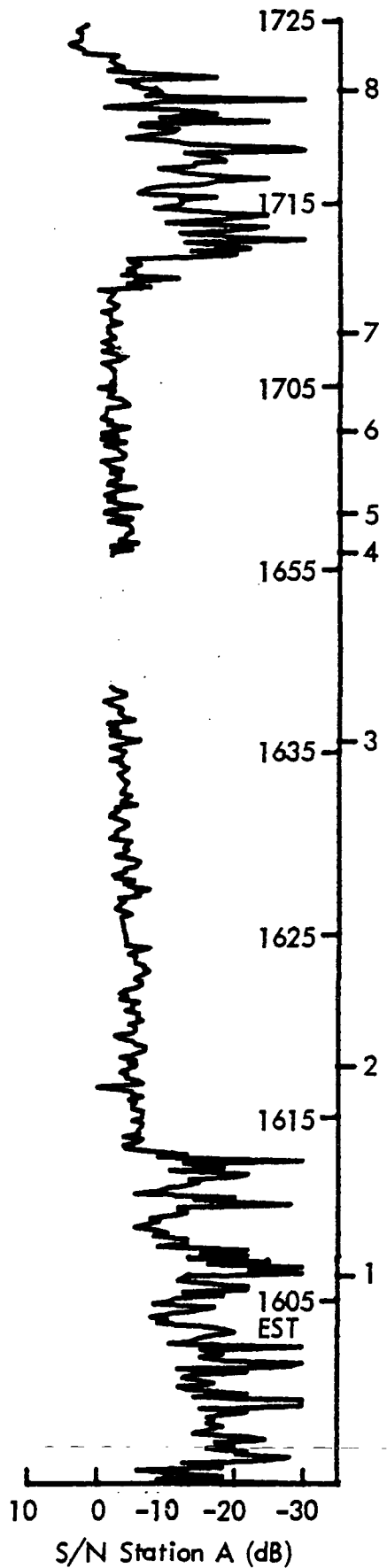

Figure B-8 . Flight 2-Z1-2, S/N Station A and B;
 FRG-BED, 1/24/75, 3500', 1556-1720 EST, 2056-2220 GMT.

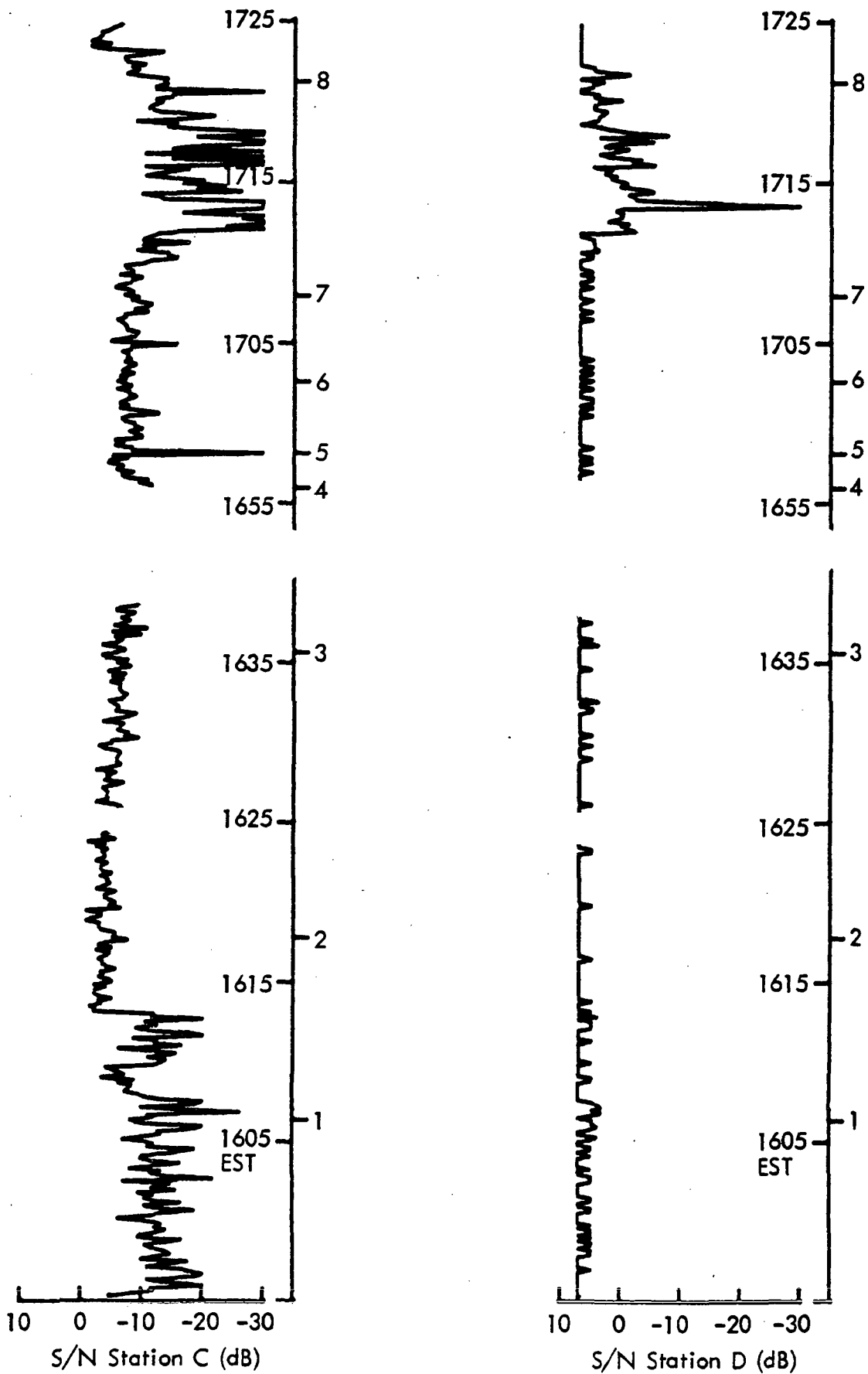

Figure B-9 . Flight 2-Z1-2, S/N Station C and D;
FRG-BED, 1/24/75, 3500', 1556-1720 EST, 2056-2220 GMT.

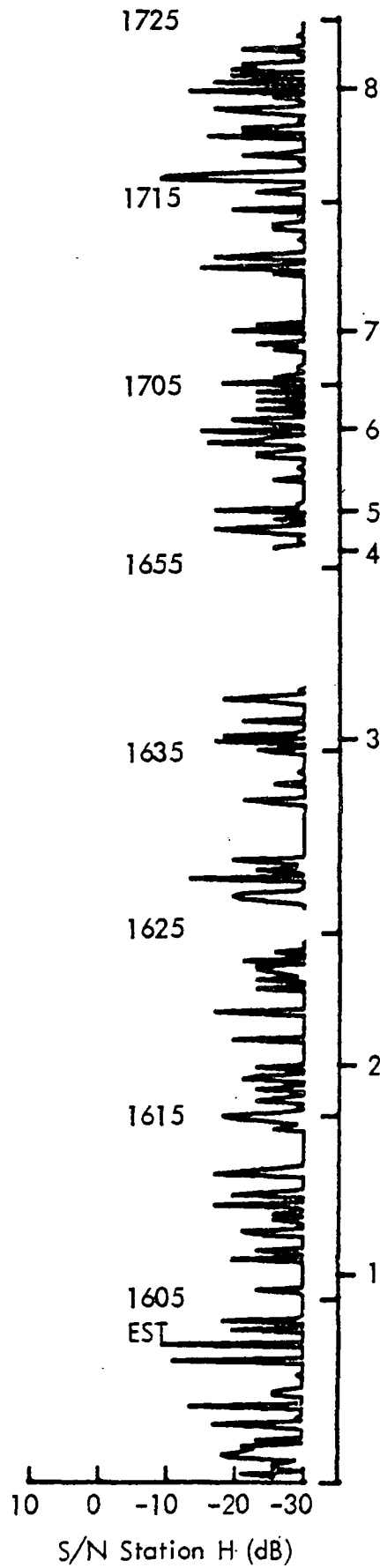

Figure B-10 . Flight 2-Z1-2, S/N Station H;
FRG-BED, 1/24/75, 3500', 1556-1720 EST, 2056-2200 GMT.

TEST DESCRIPTION

Flight No. 2-4

TEST OBJECTIVES: Short range night accuracy check and S/N observations to determine necessity for alternate mounting of receiver as well as general navigational capability check.

DATE: 1/27/75

DEPARTURE: BED, 1738 EST

DESTINATION: BED

ROUTE: BED, FIT, ORH, Marlboro, BED

ALTITUDE: 4000'

WEATHER: night VFR, 20 kts WSW

SUMMARY: Chip failure detected over Fitchburg. Accurate waypoints on return to BED, using opposite sign input on LOP 2.

KEY WORDS: Altitude effects, maneuver effects.

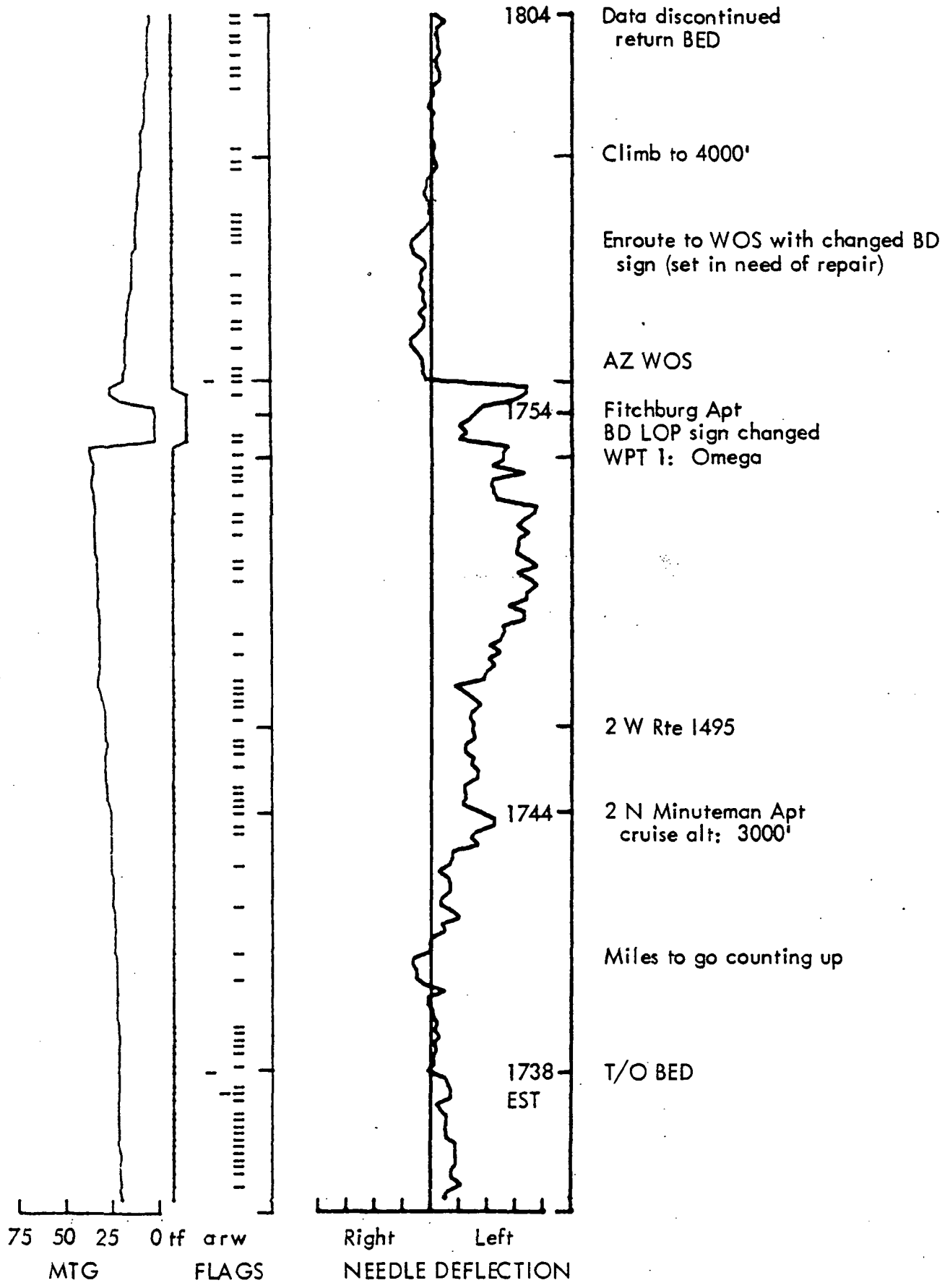

Figure B-11. Flight 2-4. Miles to Go and Needle Deflection. BED-FIT-WOS-BED, 1/27/75, 1733-1825 EST, 2233-2325 GMT.

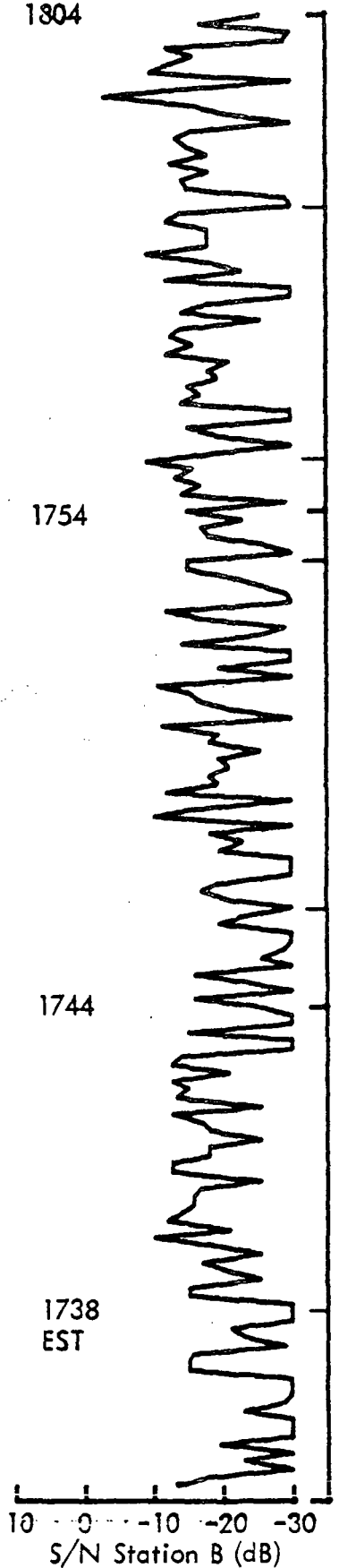
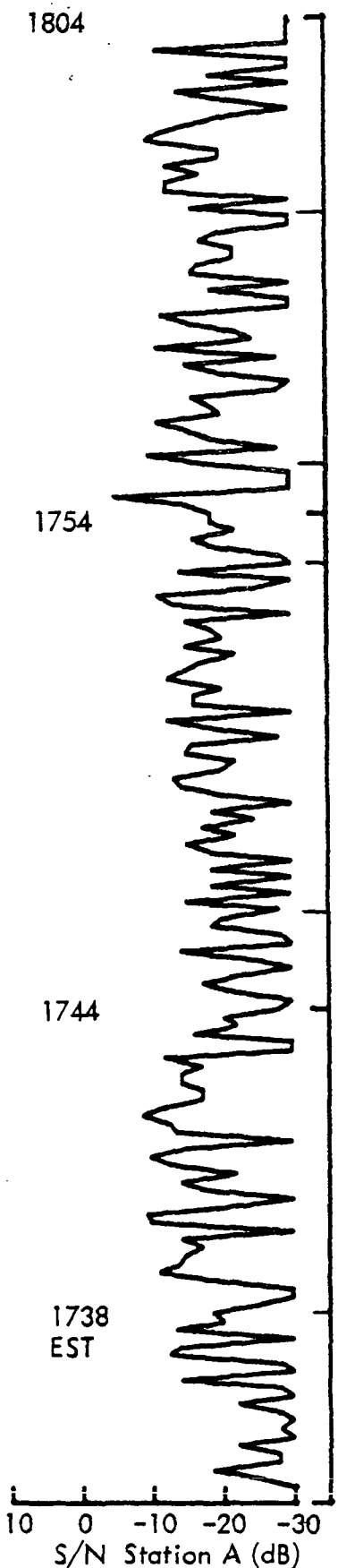

Figure B-12 . Flight 2-4 S/N Station A and B;
 BED-FIT-WOS-BED, 1/27/75, 1733-1825 EST, 2233-2325 GMT.

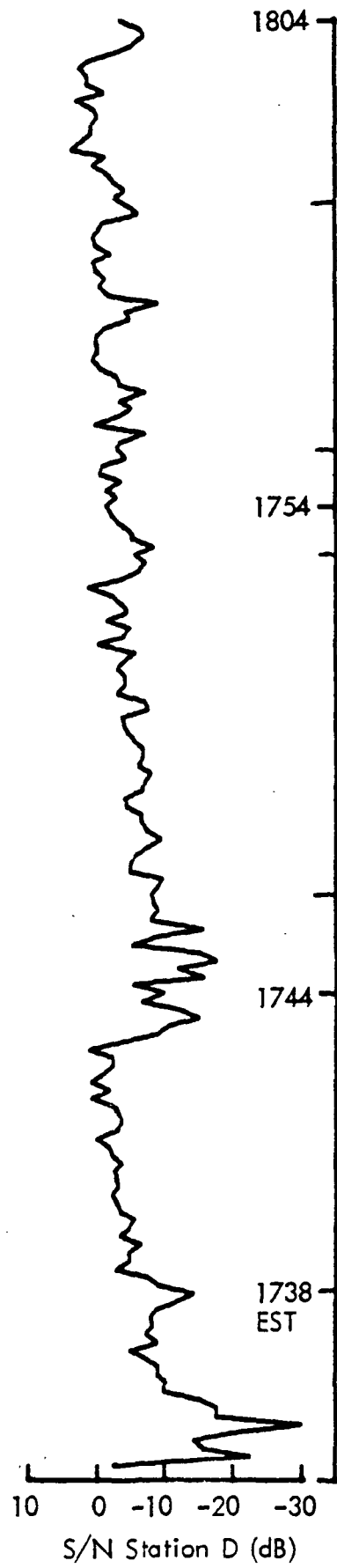
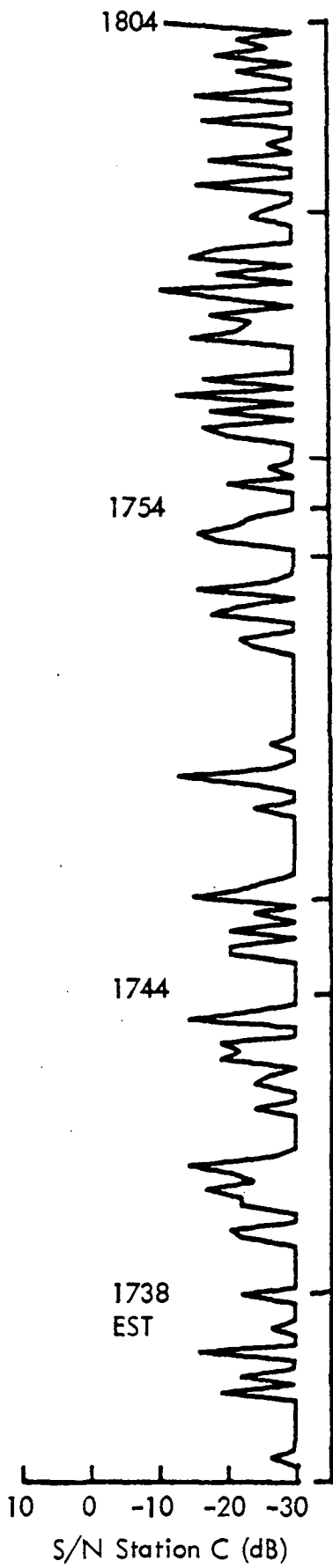

Figure B-13 . Flight 2-4, S/N Station C and D;
 BED-FIT-WOS-BED, 1/27/75, 1733-1825 EST, 2233-2325 GMT.

TEST DESCRIPTION

Flight No. 2-5

TEST OBJECTIVES: Accuracy check of waypoints with alternate LOP sign input. Leave receiver at FRG for repair.

DATE: 1/30/75

DEPARTURE: BED, 1500 EST

DESTINATION: FRG

ROUTE: BED, Marlboro, Windham,
Flying B, FRG

ALTITUDE: 2500'

WEATHER: VFR

SUMMARY: Omega receiver functioned normally on flight to Farmingdale and supplied acceptable navigation information on the flight. Omega waypoints were within a half mile of visual waypoints.

KEY WORDS: Suitability, altitude effects, terrain effects.

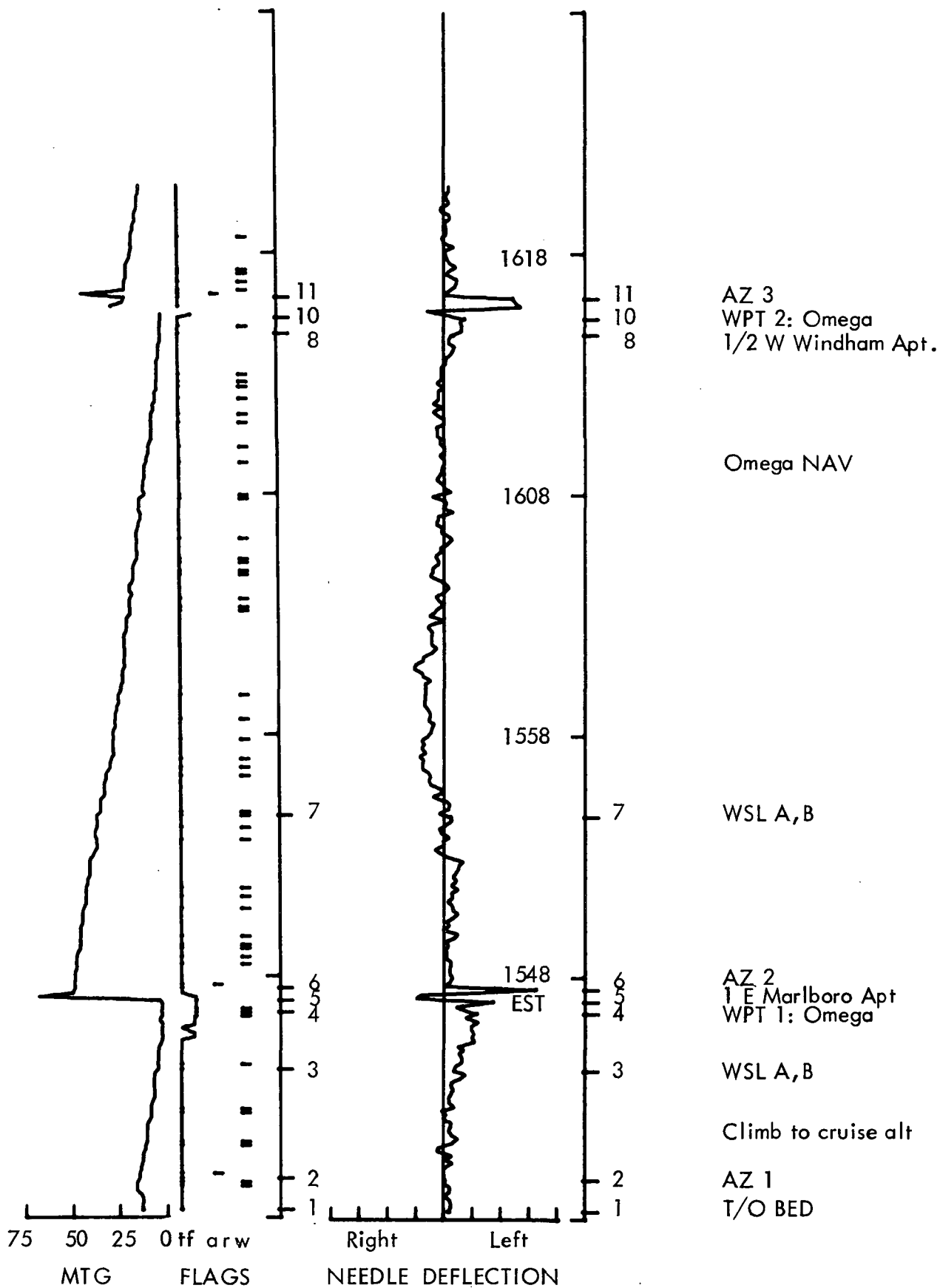

Figure B-14 . Flight 2-5, Miles To Go and Needle Deflection;
 BED-FRG, 1/30/75, 2500', 1533-1703 EST, 2033-2203 GMT.

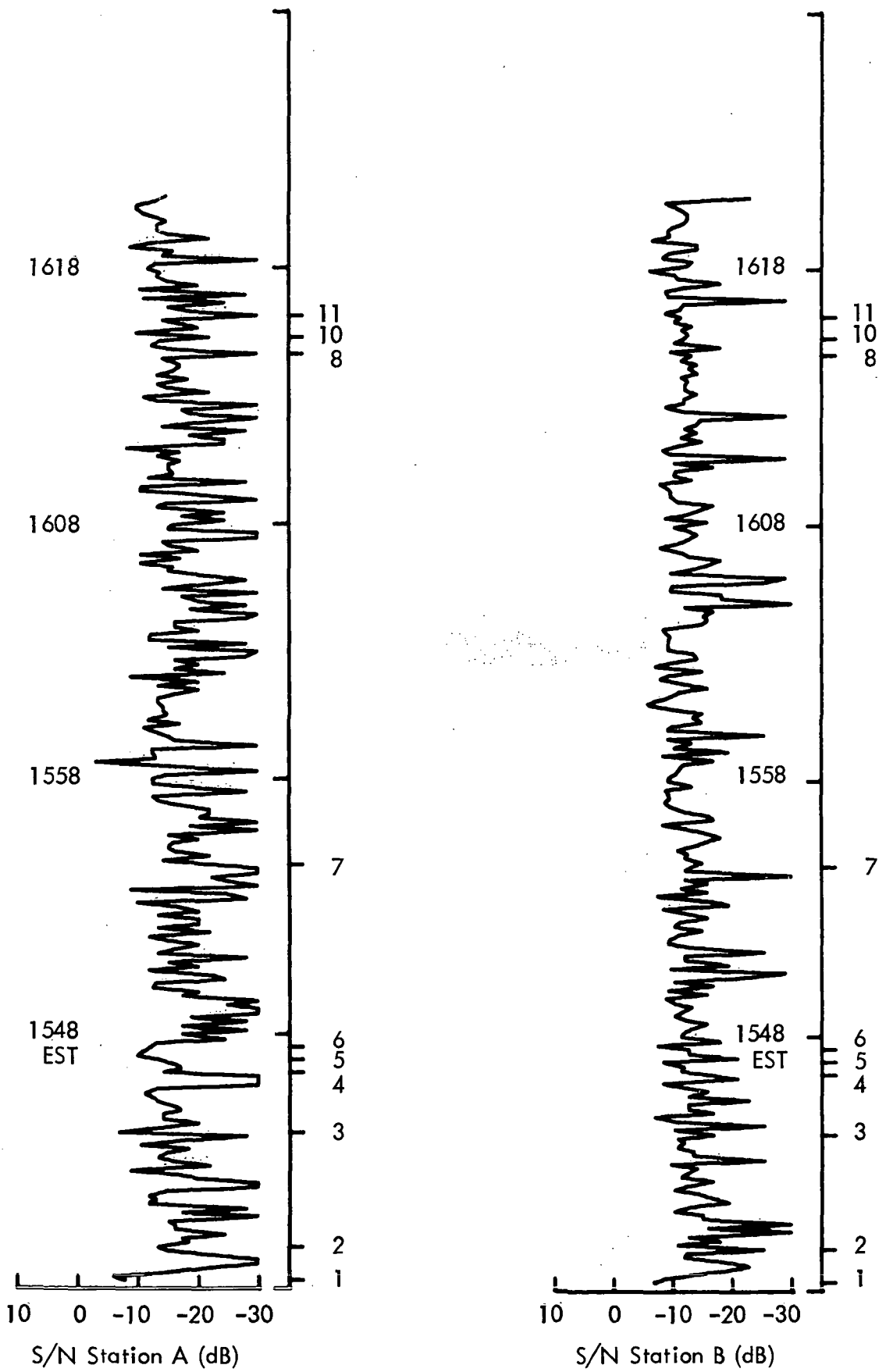

Figure B-15. Flight 2-5, S/N Station A and B;
 BED-FRG, 1/30/75, 2500', 1533-1703 EST, 2033-2203 GMT.

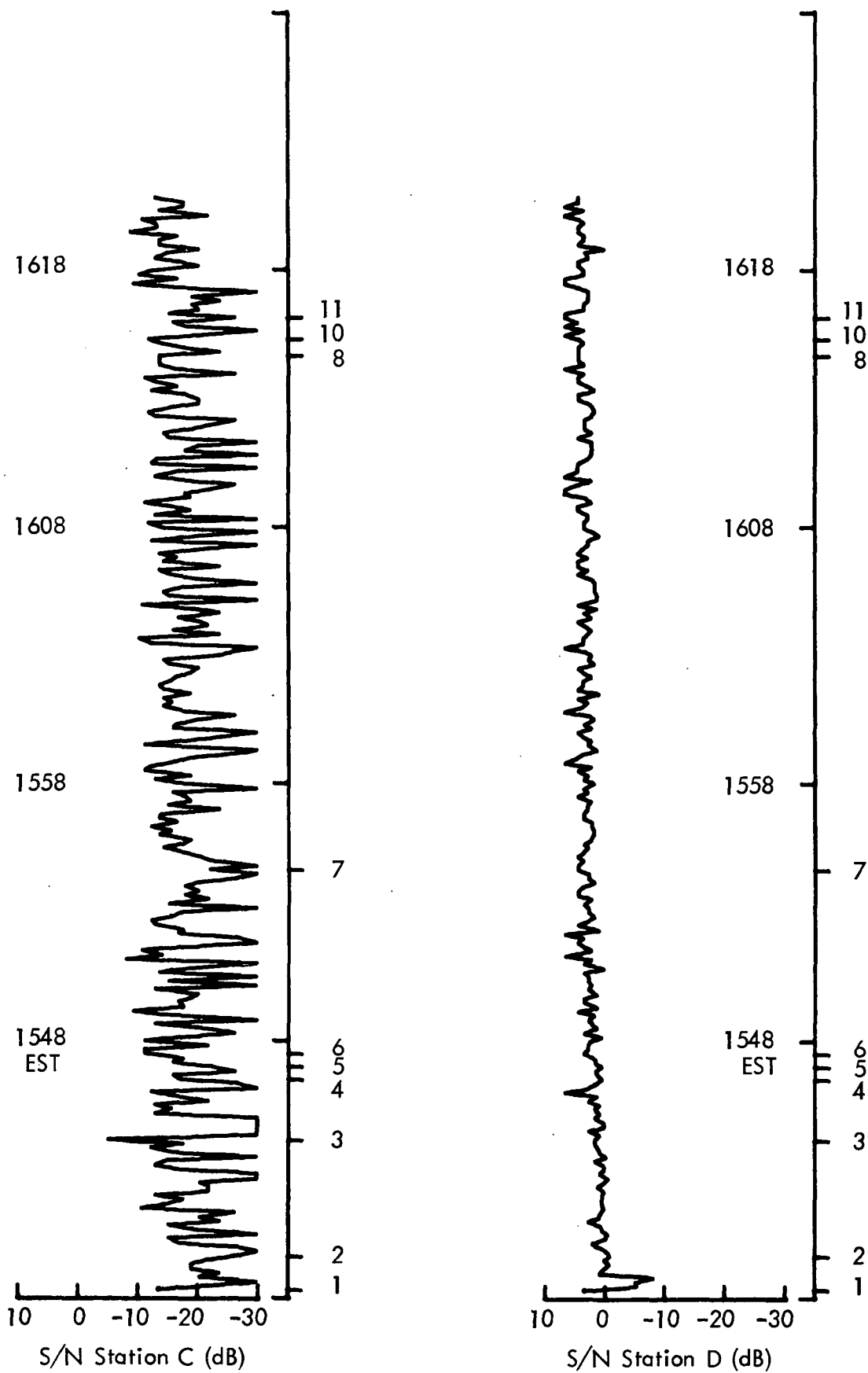

Figure B-16 . Flight 2-5, S/N Station C and D;
 BED-FRG, 1/30/75, 2500', 1533-1703 EST, 2033-2203 GMT.

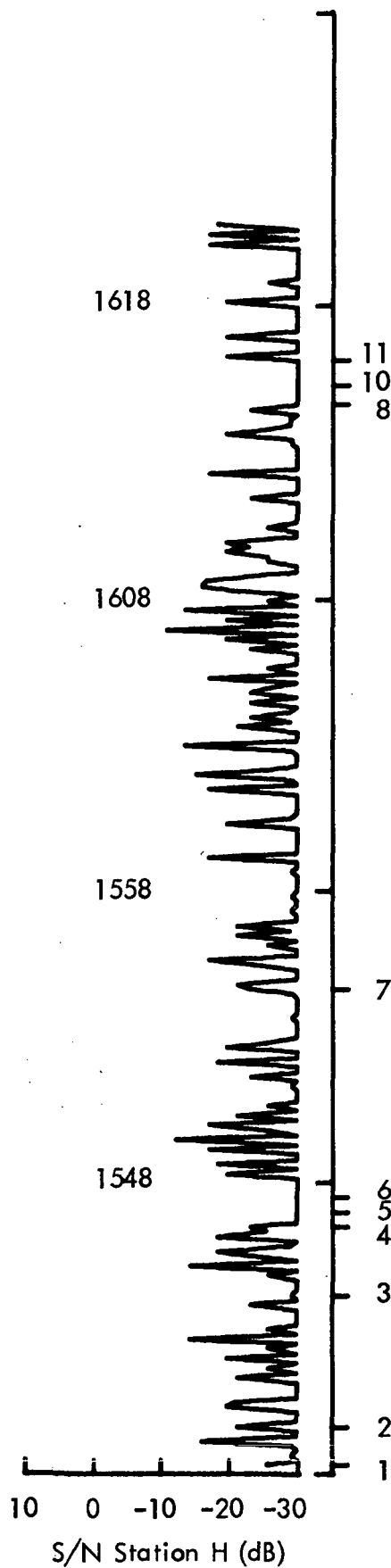

Figure B-17 . Flight 2-5, S/N Station H;
 BED-FRG, 1/30/75, 2500', 1533-1703 EST, 2033-2203 GMT.

TEST DESCRIPTION

Flight No. 2-6

TEST OBJECTIVES: Single waypoint long distance flight to fully employ Omega RNAV capability.

DATE: 1/31/75 DEPARTURE: FRG, 1834 EST
DESTINATION: BED ROUTE: FRG-BED direct
ALTITUDE: 5500' WEATHER: Night VFR, calm

SUMMARY: After radios were turned off, receiver indications became very stable. Little observable coast effect at altitude. Indicated waypoint was one mile short of actual.

KEY WORDS: Suitability, altitude effects, terrain effects.

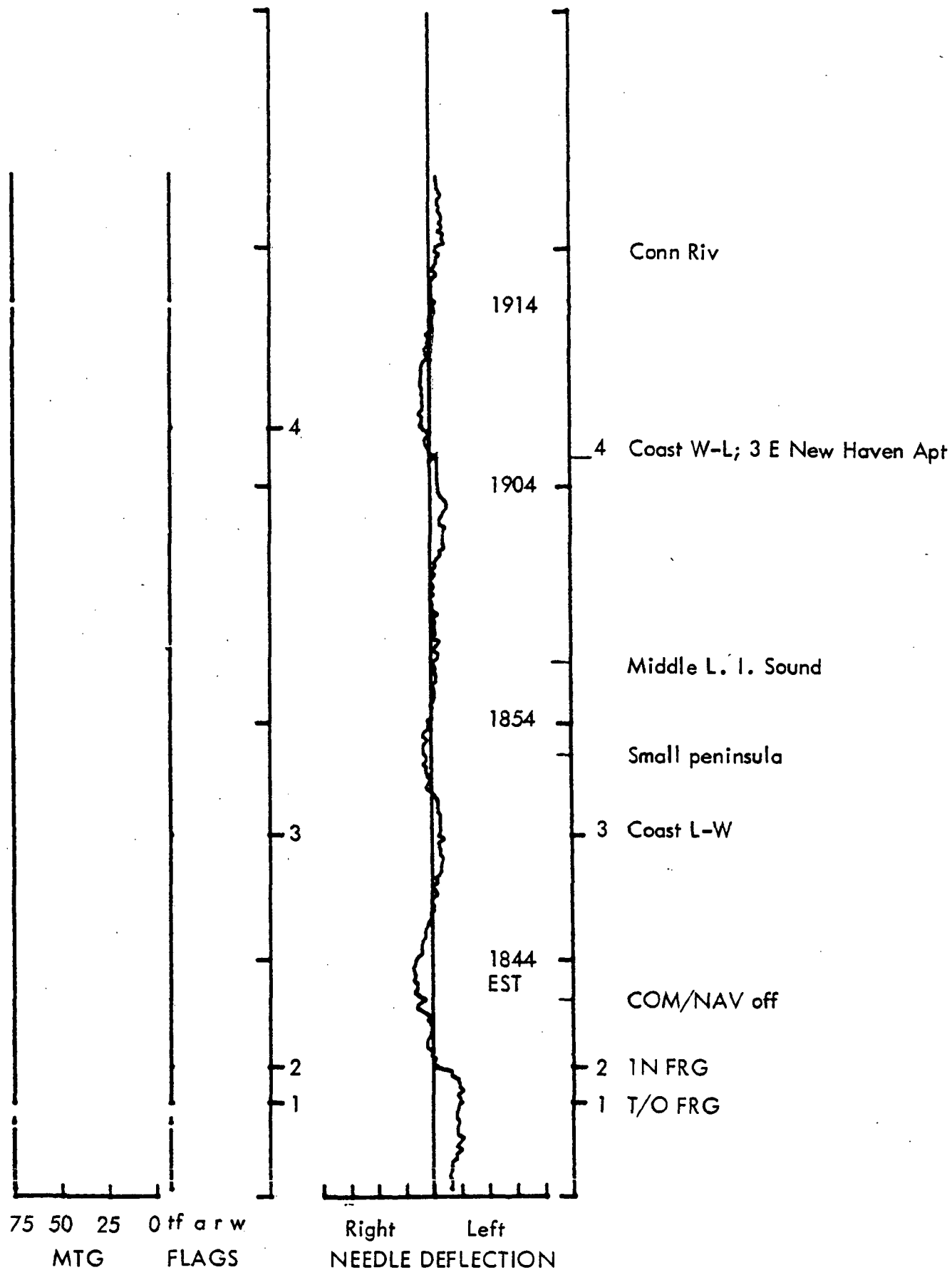
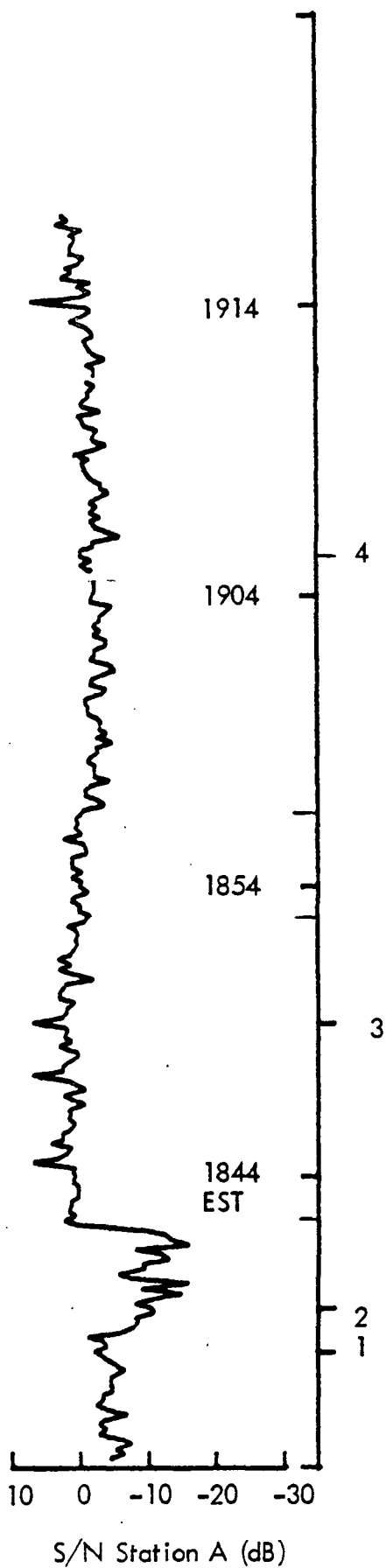
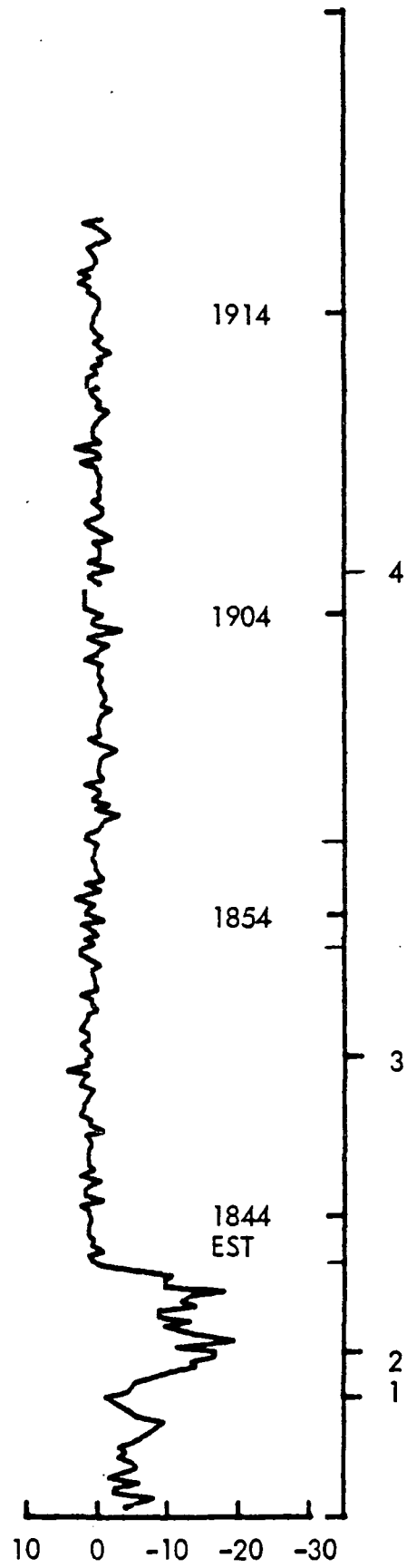

Figure B-18 . Flight 2-6 (First 45 min.), Miles to Go and Needle Deflection;
FRG-BED, 1/31/75, 5500', 1834-2004 EST, 2334-0104 GMT.



S/N Station A (dB)



S/N Station B (dB)

Figure B-19. Flight 2-6 (First 45 min.), S/N Station A and B; FRG-BED, 1/31/75, 5500', 1834-2004 EST, 2334-0104 GMT.

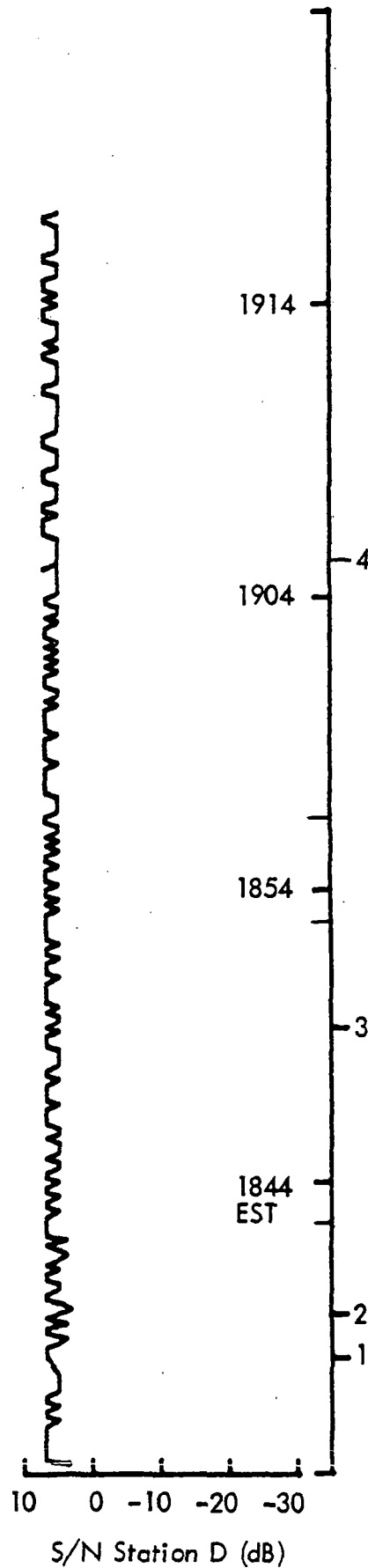
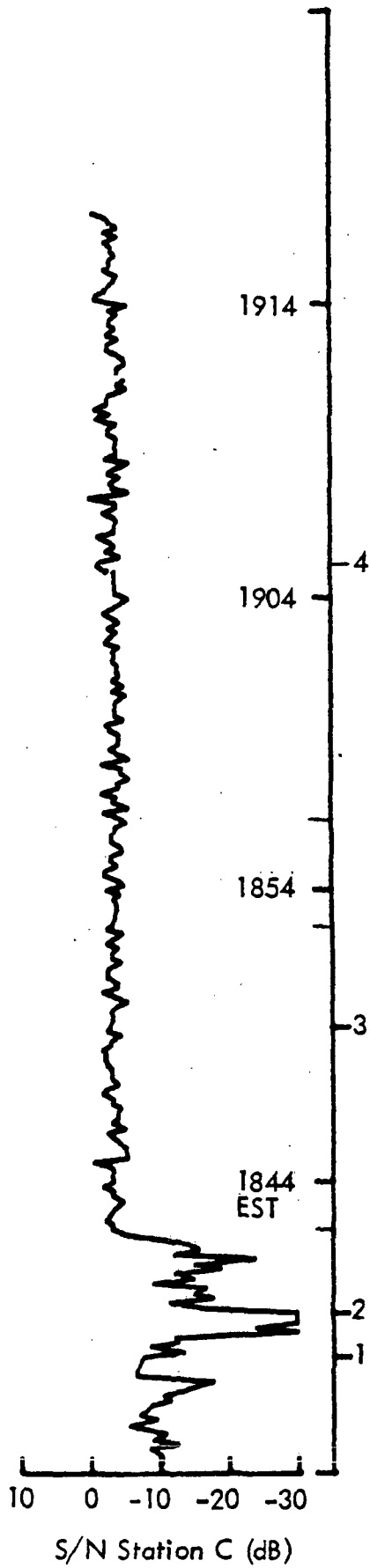

Figure B-20 . Flight 2-6 (First 45 min.), S/N Station C and D;
FRG-BED, 1/31/75, 5500', 1834-2004 EST, 2334-0104 GMT.

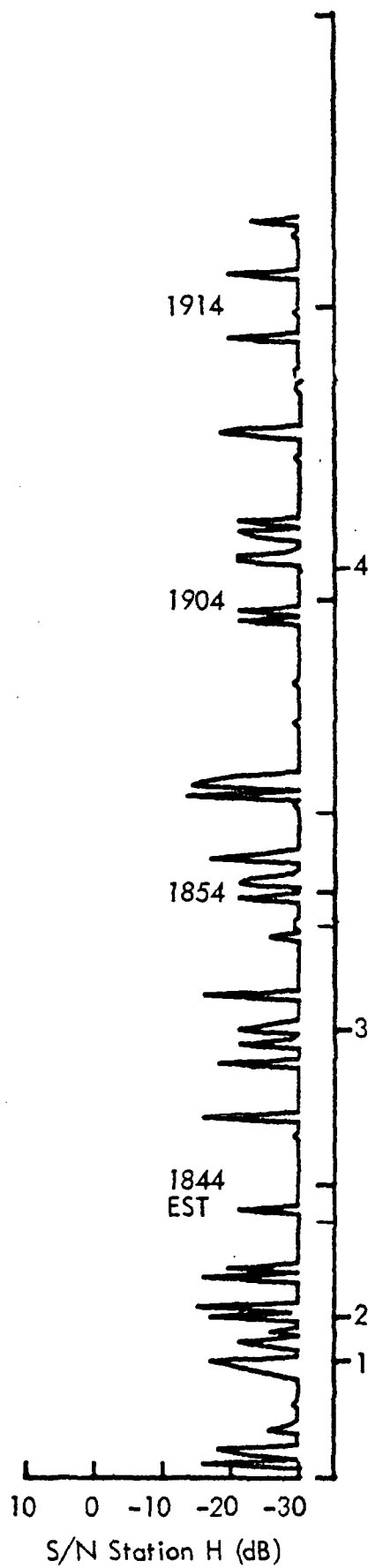

Figure B-21 . Flight 2-6 (First 45 min.), S/N Station H;
 FRG-BED, 1/31/75, 5500', 1834-2004 EST, 2334-0104 GMT.

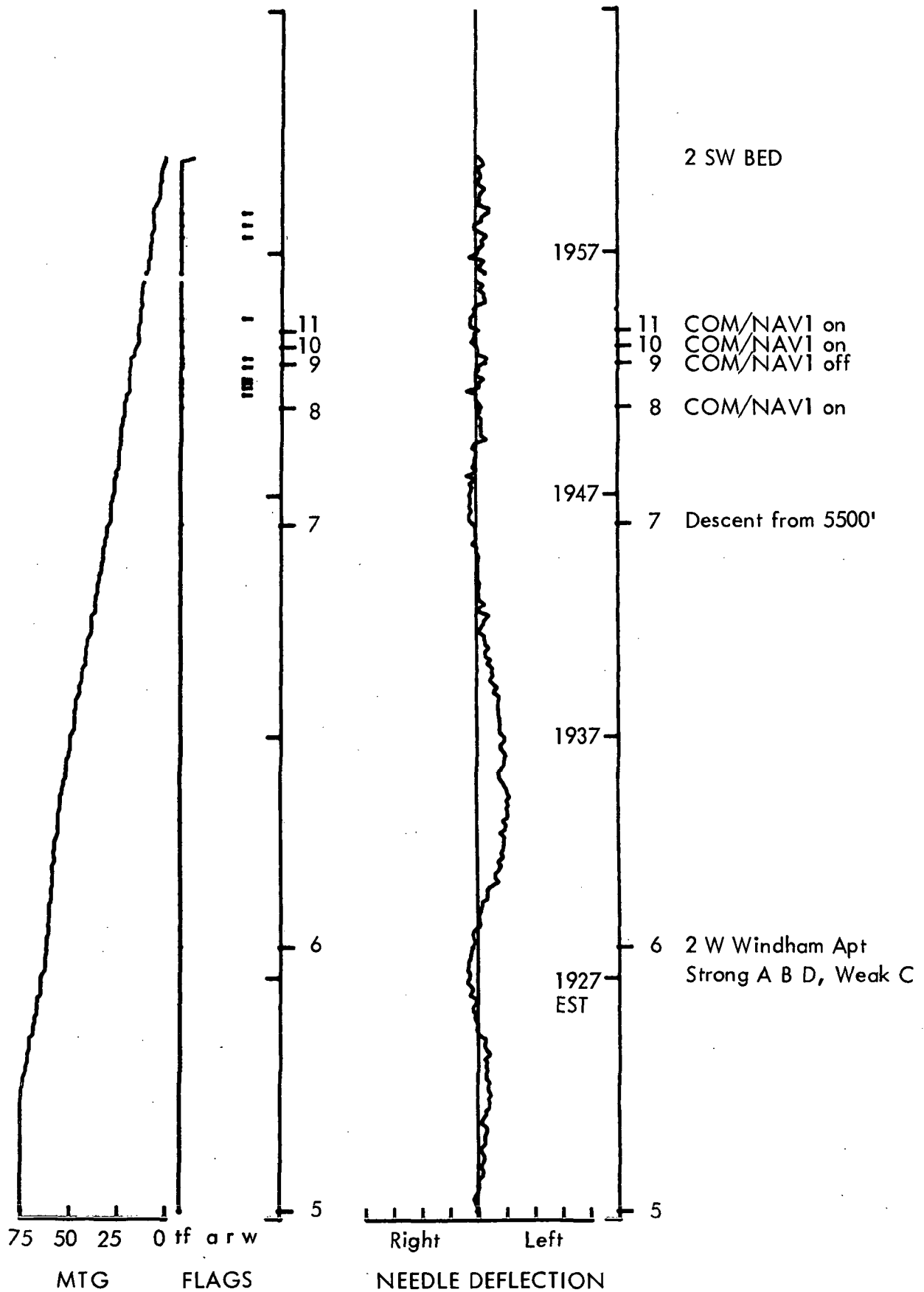

Figure B-22 . Flight 2-6 (cont.), Miles to Go and Needle Deflection;
FRG-BED, 1/31/75, 550', 1830-2000 EST, 2330-0100 GMT.

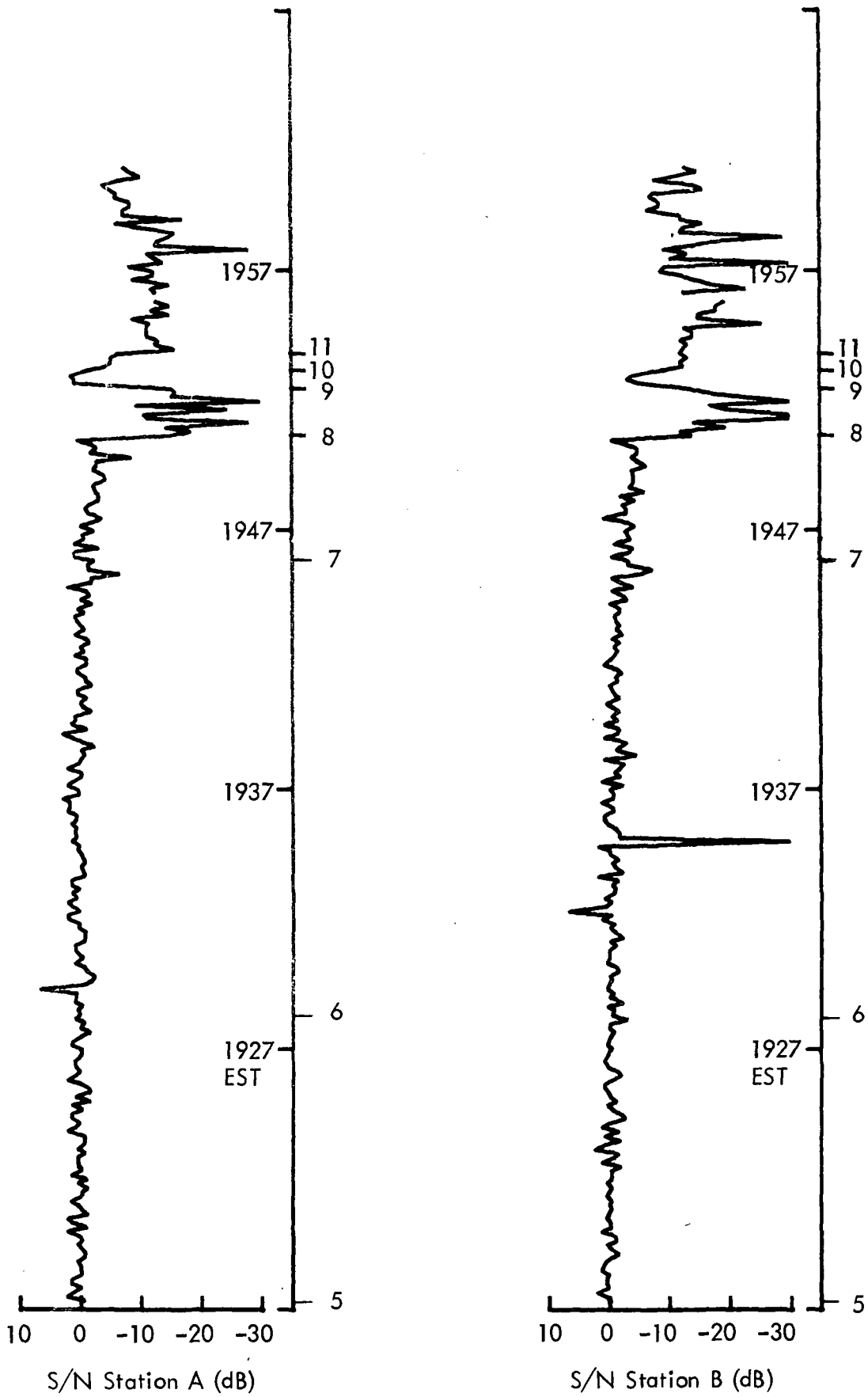

Figure B-23 . Flight 2-6 (cont.), S/N Station A and B;
FRG-BED, 1/31/75, 5500', 1830-2000 EST, 2330-0100 GMT.

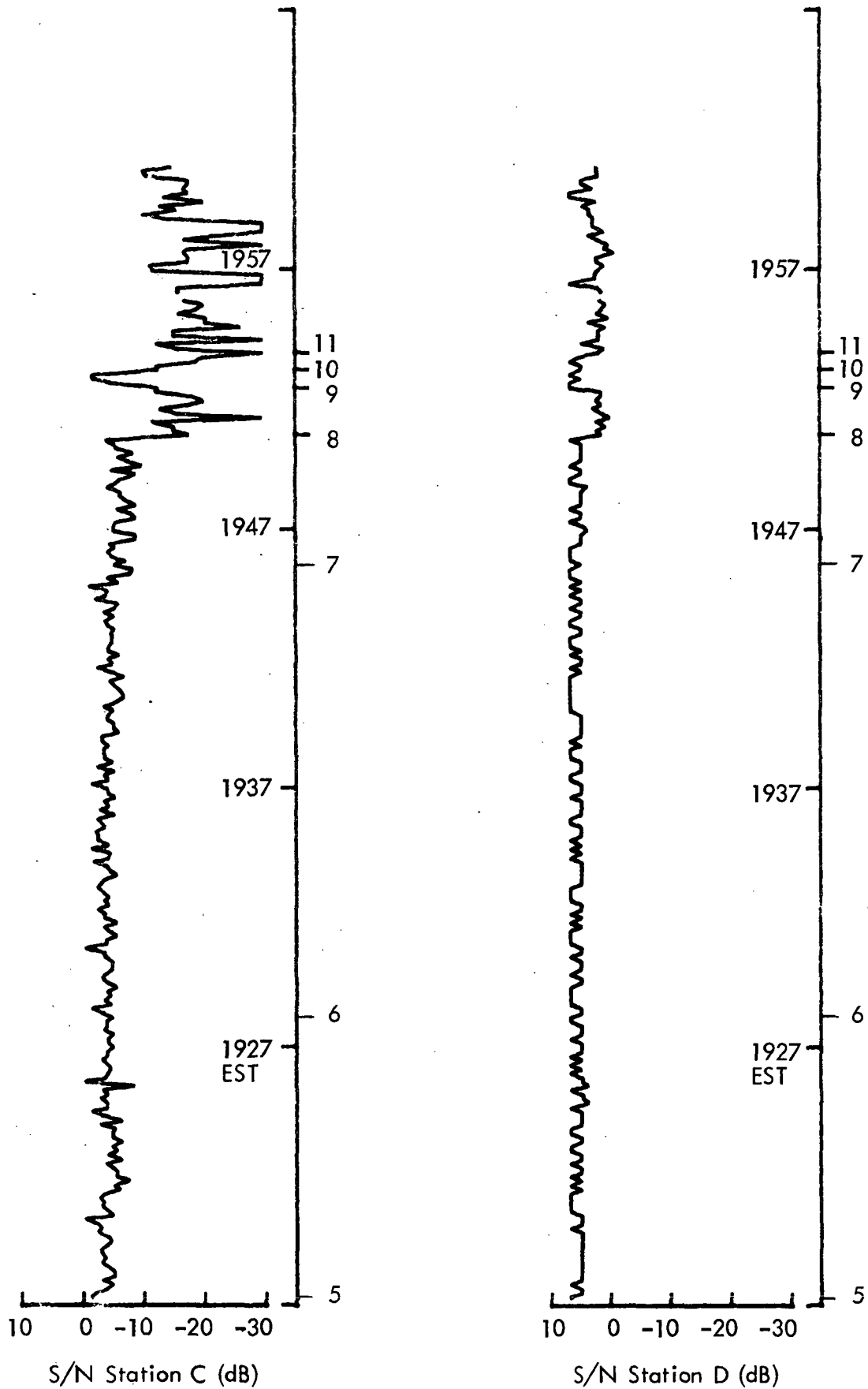

Figure B-24 . Flight 2-6 (cont.), S/N Station C and D;
FRG-BED, 1/31/75, 5500', 1830-2000 EST, 2330-0100 GMT.

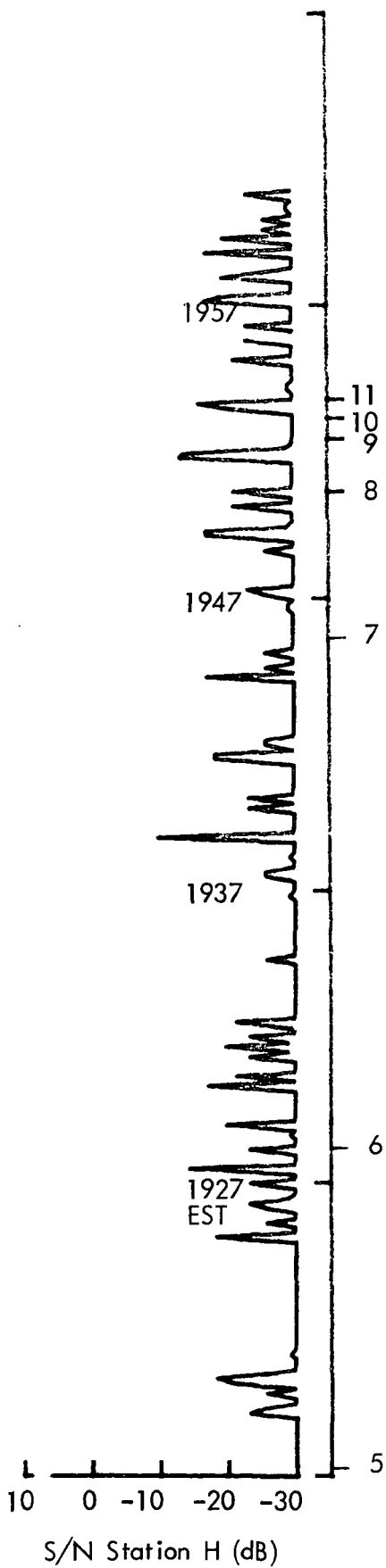

Figure B-25 . Flight 2-6 (cont.), S/N Station H;
FRG-BED, 1/31/75, 5500', 1830-2000 EST, 2330-0100 GMT.

TEST DESCRIPTION

Flight No. 2 - 7

TEST OBJECTIVES: Obtain S/N data at low altitude near: television transmitters, urban areas, over power lines, and during maneuvers. Determine ability to maintain holding pattern and fly approach, in the shadow of Mt. Wachusett.

DATE: 2/7/75

DEPARTURE: BED, 1617 EST

DESTINATION: BED

ROUTE: BED, towers, Framingham, GDM, Haystack, powerline, BED

ALTITUDE: 1000' AGL, 200' over pwr ln

WEATHER: Night SVFR in scattered snow showers, 5 kts NW

SUMMARY: Flew to avoid snow showers, completed two and a half orbits around Norwood television towers at 2000', 1500' and 1000' MSL, with no effect on indicators or increase in weak signal lights. This was also true of flight over Framingham powerlines and during maneuvers (stalls, spirals and steep banked turns). An RNAV approach was made to Gardner Airport with waypoint indication 1/4S of the actual airport. Holding patterns were difficult to fly due to moderate noise in the station A signal. *

KEY WORDS: Suitability, altitude effects, terrain effects, maneuver effects.

*Recorded data was lost in software transfer. See Flight No. 2-21.

TEST DESCRIPTION

Flight No. 2-8

TEST OBJECTIVES: Fly low altitude Zulu routes from BED to College Park, Maryland, and return employing Zulu routes.

DATE: 2/10/75

DEPARTURE: BED, 1009 EST

DESTINATION: Flushing

ROUTE: Zulu-2 to Statue, divert Flushing

ALTITUDE: 2000'

WEATHER: VFR, 20 kts W, slight haze

SUMMARY: Flight proceeded as planned until passing the Statue of Liberty when Station D (North Dakota) ceased transmitting. A return to Flushing Airport was made by pilotage.*

KEY WORDS: Suitability, altitude effects, terrain effects.

* Second half of recorded data was lost in software transfer.

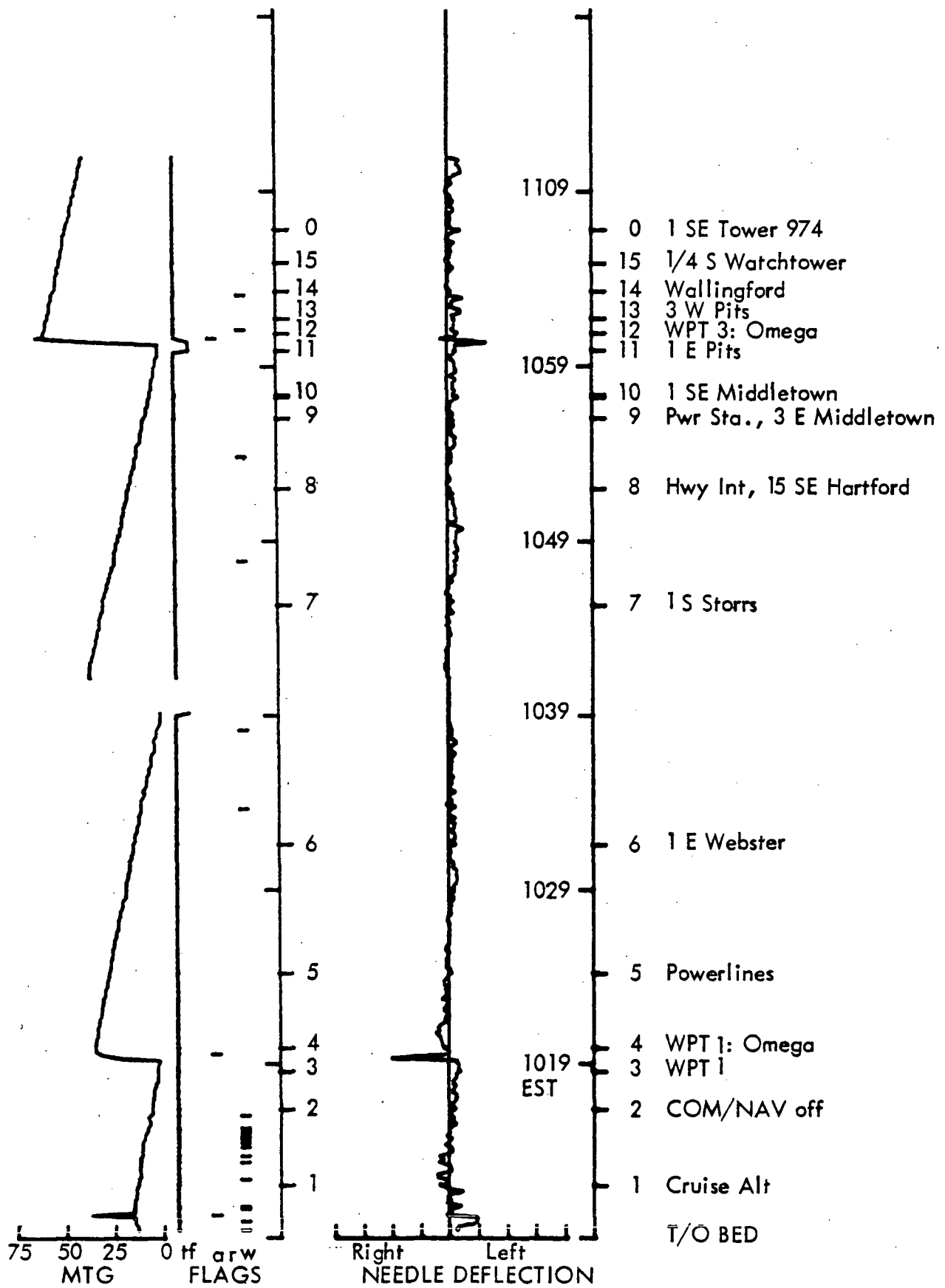

Figure B-26. Flight 2-8 (First 62 min.) Miles to go and Needle Deflection; BED-Flushing, 2/10/75, 2000', 1009-1215 EST, 1509-1715 GMT.

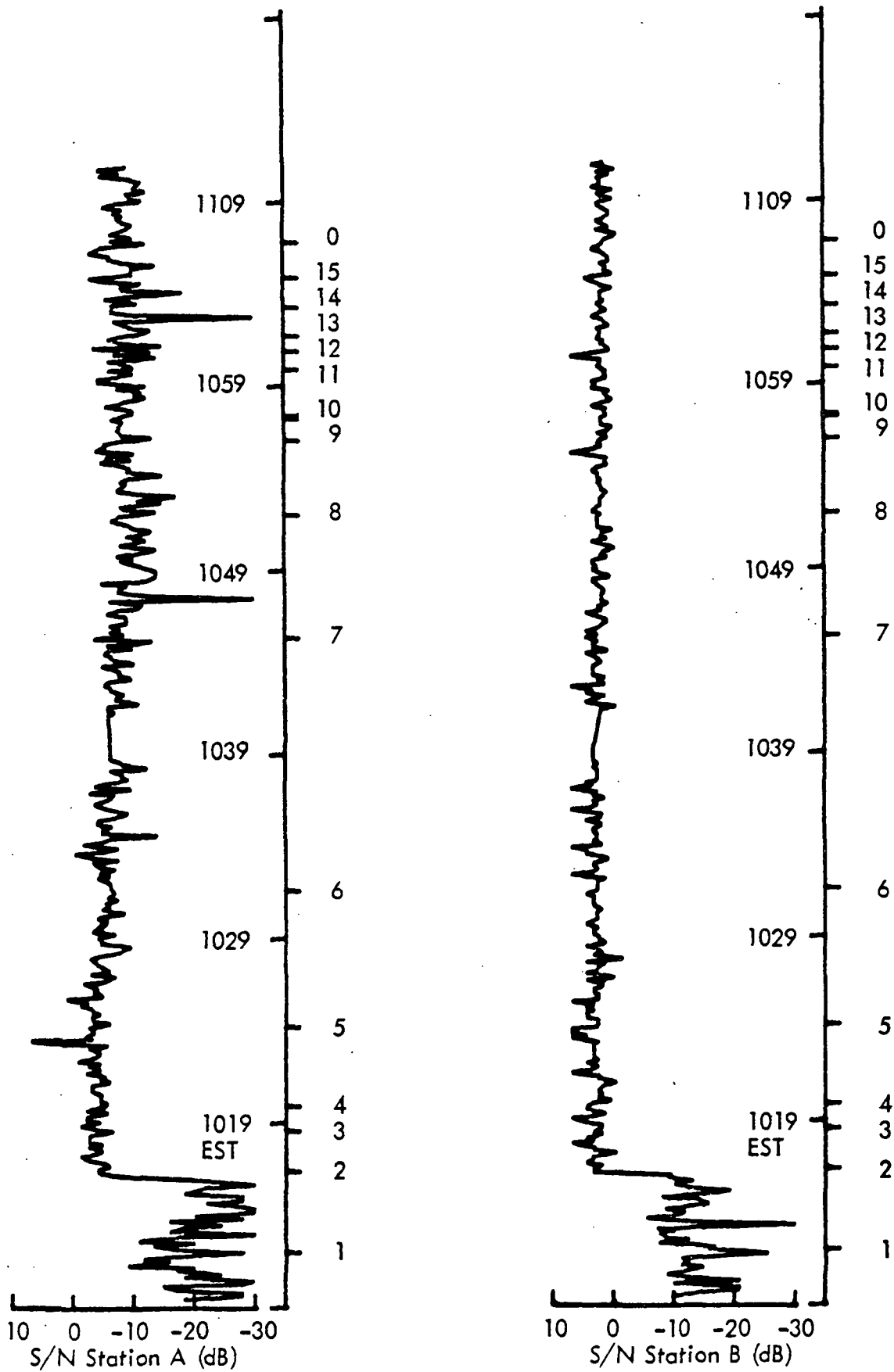

Figure B-27. Flight 2-8 (First 62 min.), S/N Station A and B; BED-Flushing, 2/10/75, 2000', 1009-1215 EST, 1509-1715 GMT.

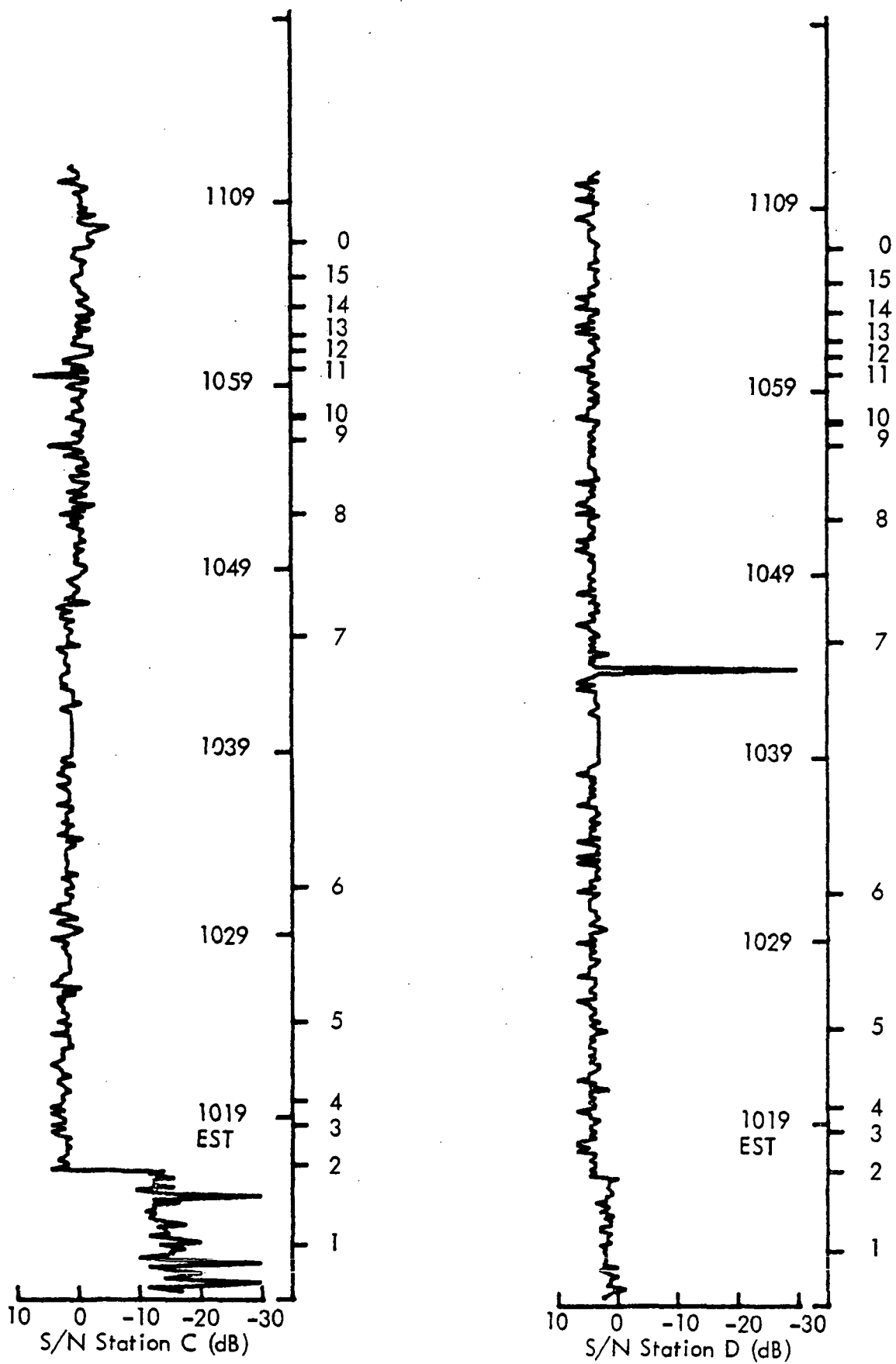

Figure B-28. Flight 2-8 (First 62 min.) S/N Station C and D; BED-Flushing, 2/10/75, 2000' 1009-1215 EST, 1509-1715 GMT.

TEST DESCRIPTION

Flight No. 2-9

TEST OBJECTIVES: Test alternate LOP pairs AB and BC. Fly alternate Zulu routes to BED from Flushing after losing track when station D stopped transmitting.

DATE: 2/10/75

DEPARTURE: Flushing, 1300 EST

DESTINATION: BED

ROUTE: Flushing, BDR, Windham, BED

ALTITUDE: 2000'

WEATHER: VFR, 20 kts W

SUMMARY: Experienced difficulty obtaining station synchronization at Flushing. Reset using AB and BD LOPs as station D had returned momentarily. Lost track over twr 376 waypoint when station D stopped again. Reset over BDR using AB and BC LOPs, and returned to BED successfully.*

KEY WORDS: Suitability, altitude effects, terrain effects.

* Recorded data was lost in software transfer.

TEST DESCRIPTION

Flight No. 2-10

TEST OBJECTIVES: Fly low altitude Zulu routes from BED to College Park, Maryland, using stations A, B, C

DATE: 2/14/75 DEPARTURE: BED, 1000 EST

DESTINATION: College Park ROUTE: Z2 and ZW

ALTITUDE: 2000', 1100' under WEATHER: VFR, 10 kts SW
TCA

SUMMARY: Low altitude Zulu routes were flown from Bedford to Washington area. As the flight proceeded, the waypoint indications were increasingly early due to possible calculation error. Approaching the Susquehanna River it was determined that A-B LOP had shifted by 2 lanes. The final waypoint indication was 2 miles late with the altered LOP inputs.

KEY WORDS: Suitability, altitude effects.

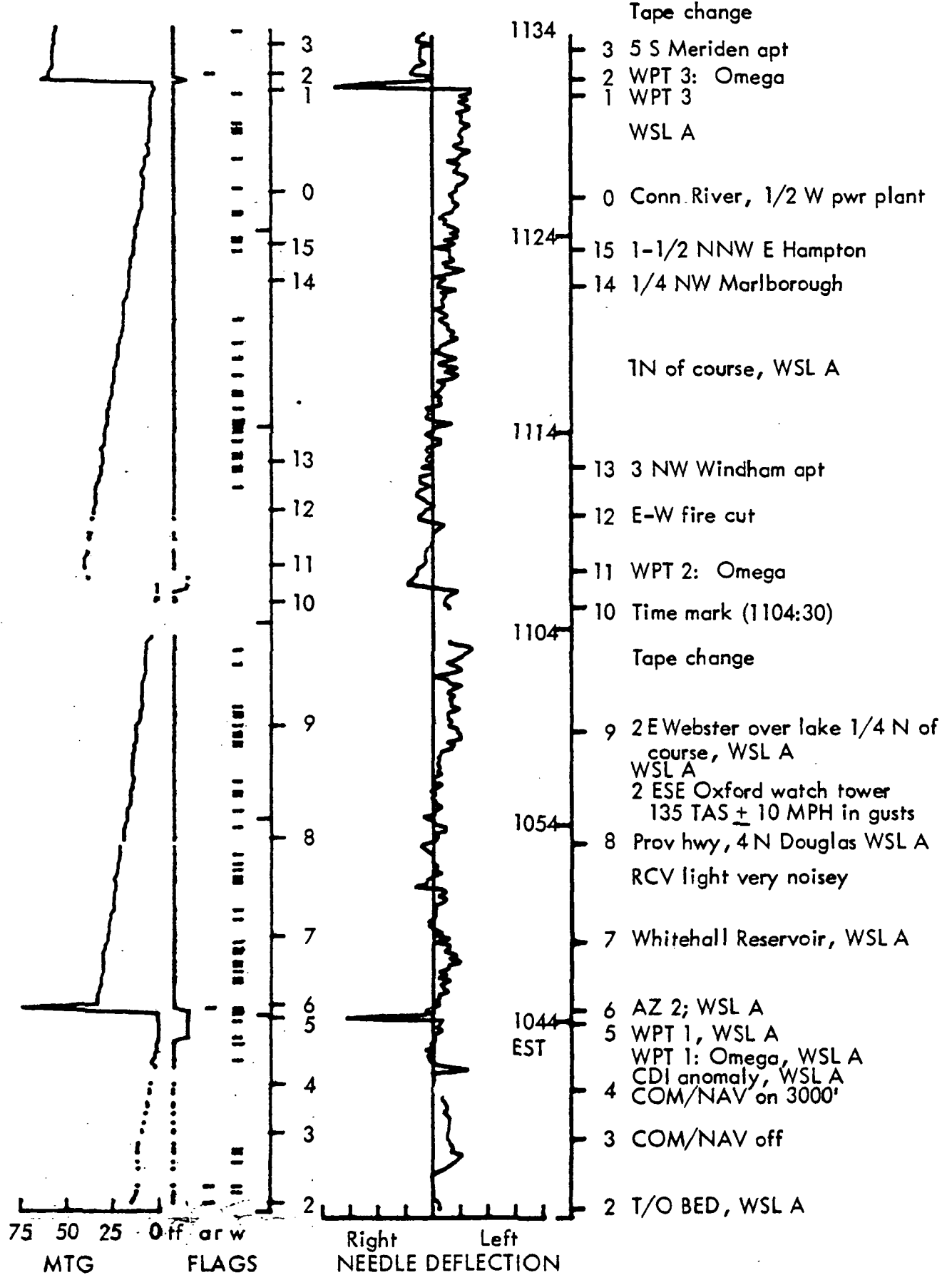

Figure B-29 . Flight 2-10 (First 60 Min), Miles to Go and Needle Deflection;
BED-College Park, 2/14/75, 2000', 1034-1413 EST, 1534-1913 GMT.

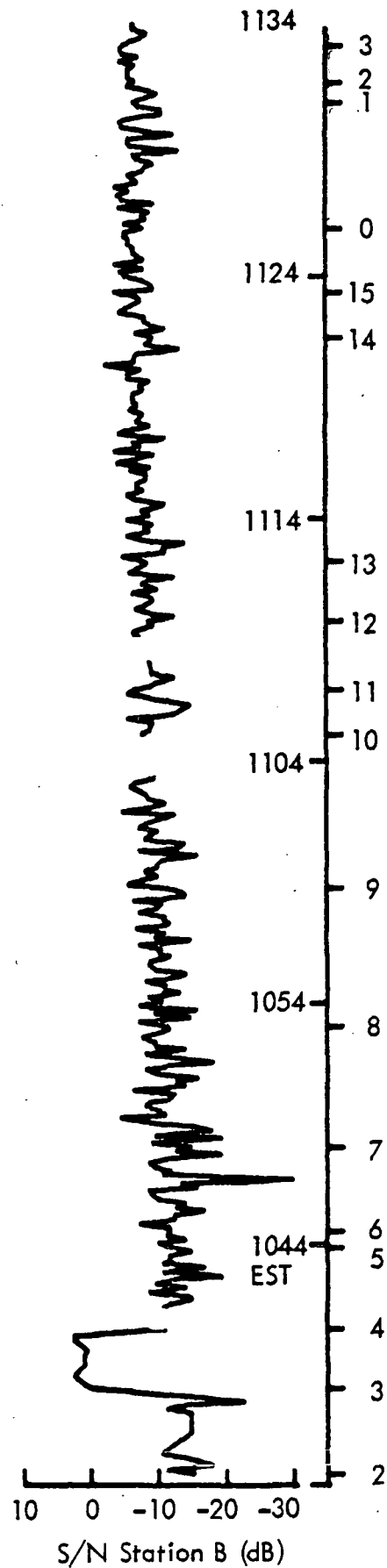
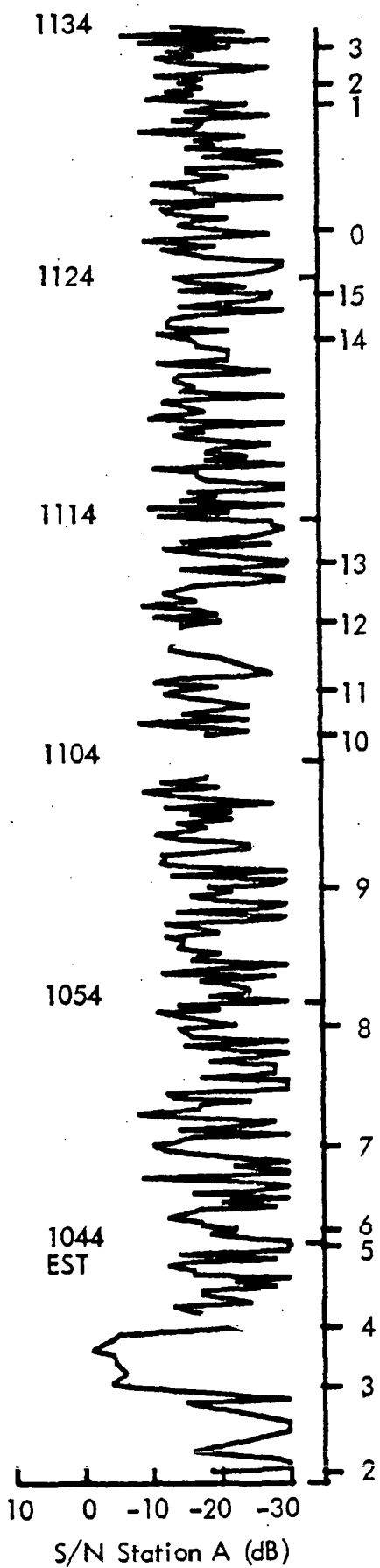

Figure B-30 . Flight 2-10 (First 60 Min), S/N Station A and B;
 BED-College Park, 2/14/75, 2000', 1034-1413 EST, 1534-1913 GMT.

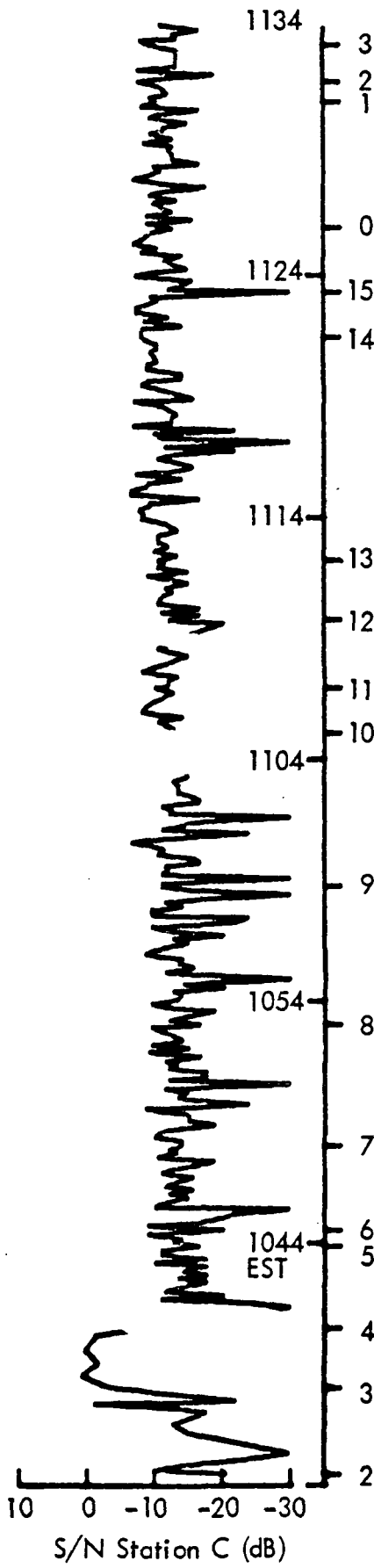

Figure B-31 . Flight 2-10 (First 60 Min), S/N Station C;
 BED-College Park, 2/14/75, 2000', 1034-1413 EST, 1534-1913 GMT.

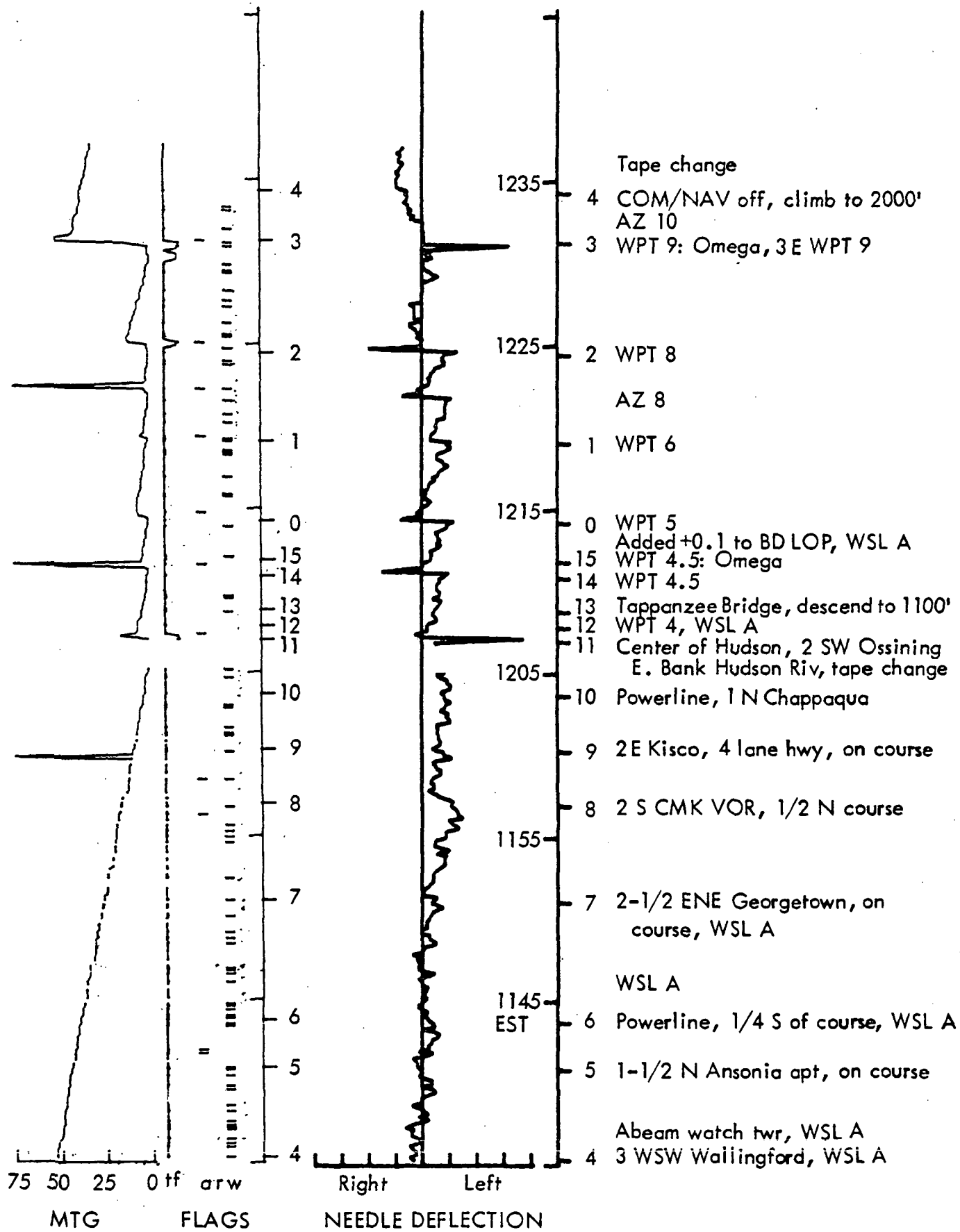

Figure B-32 . Flight 2-10 (Second 63 Min), Miles to Go and Needle Deflection;
 BED-College Park, 2/14/75, 2000', 1034-1413 EST, 1534-1913 GMT.

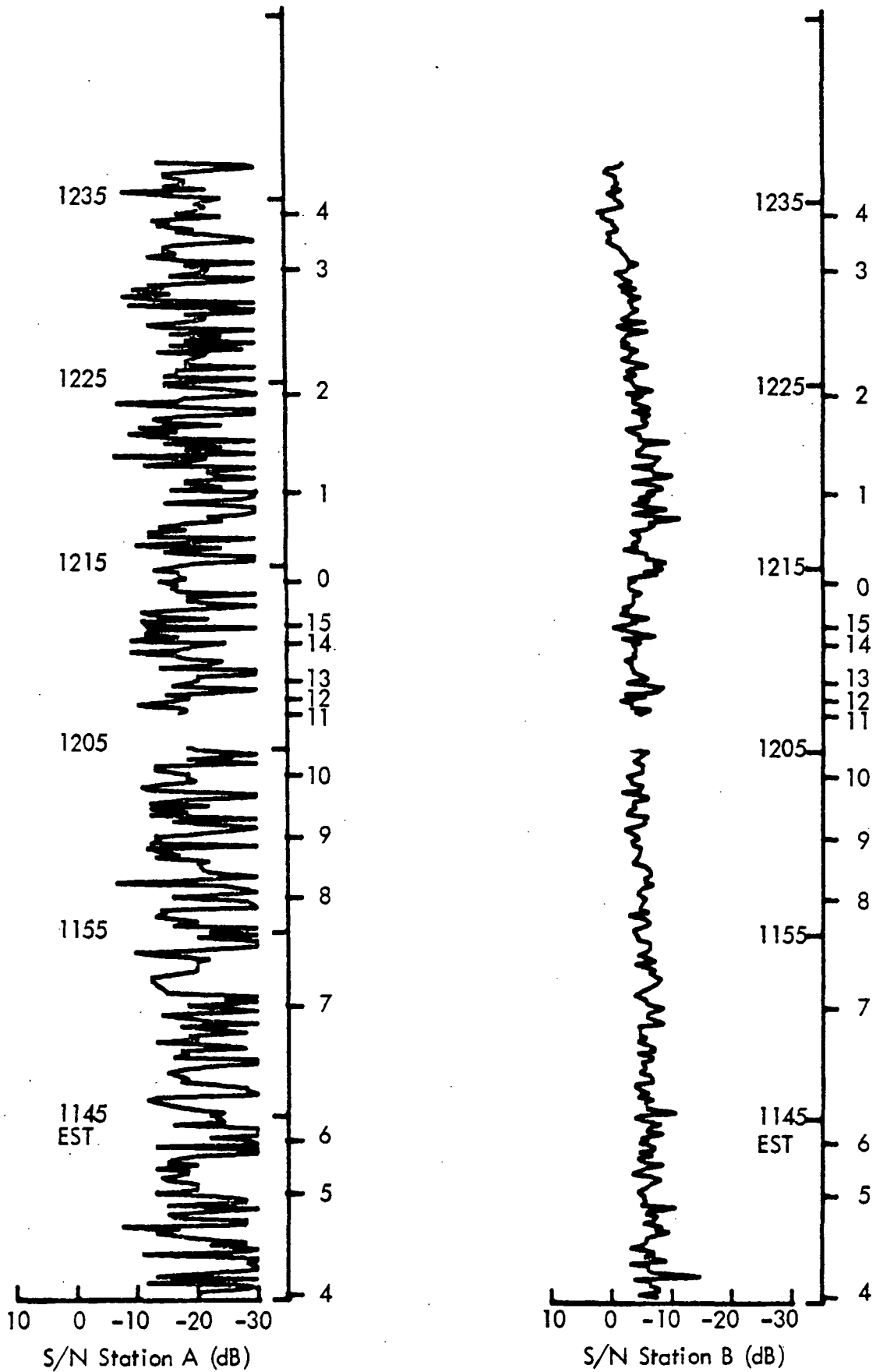

Figure B-33 . Flight 2-10 (Second 63 Min), S/N Station A and B;
 BED-College Park, 2/14/75, 2000', 1034-1413 EST, 1534-1913 GMT.

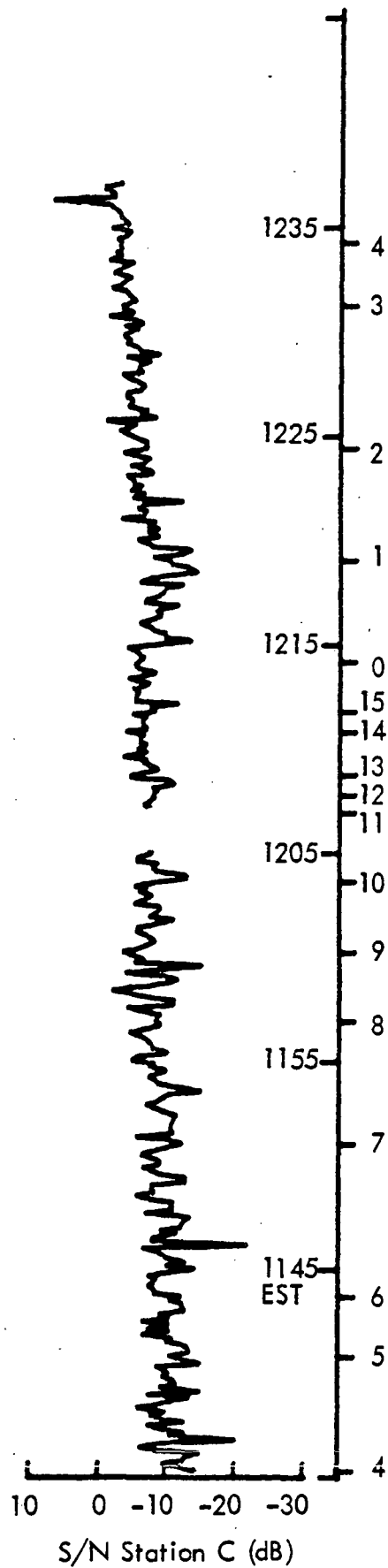

Figure B-34 . Flight 2-10 (Second 63 Min), S/N Station C;
 BED-College Park, 2/14/75, 2000', 1034-1413 EST, 1534-1913 GMT.

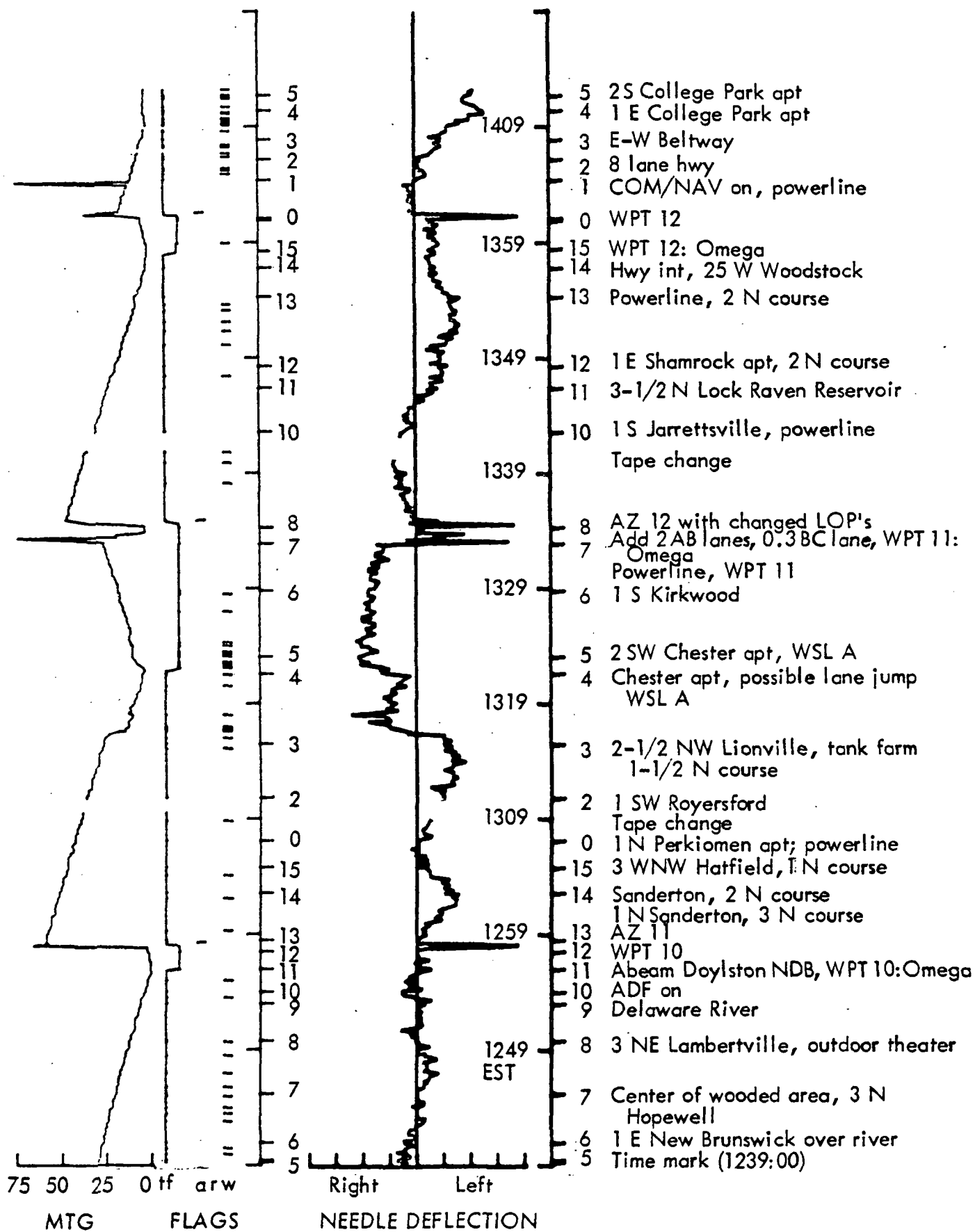

Figure B-35 . Flight 2-10 (Third 93 Min), Miles to Go and Needle Deflection;
 BED-College Park, 2/14/75, 2000', 1034-1413 EST, 1534-1913 GMT.

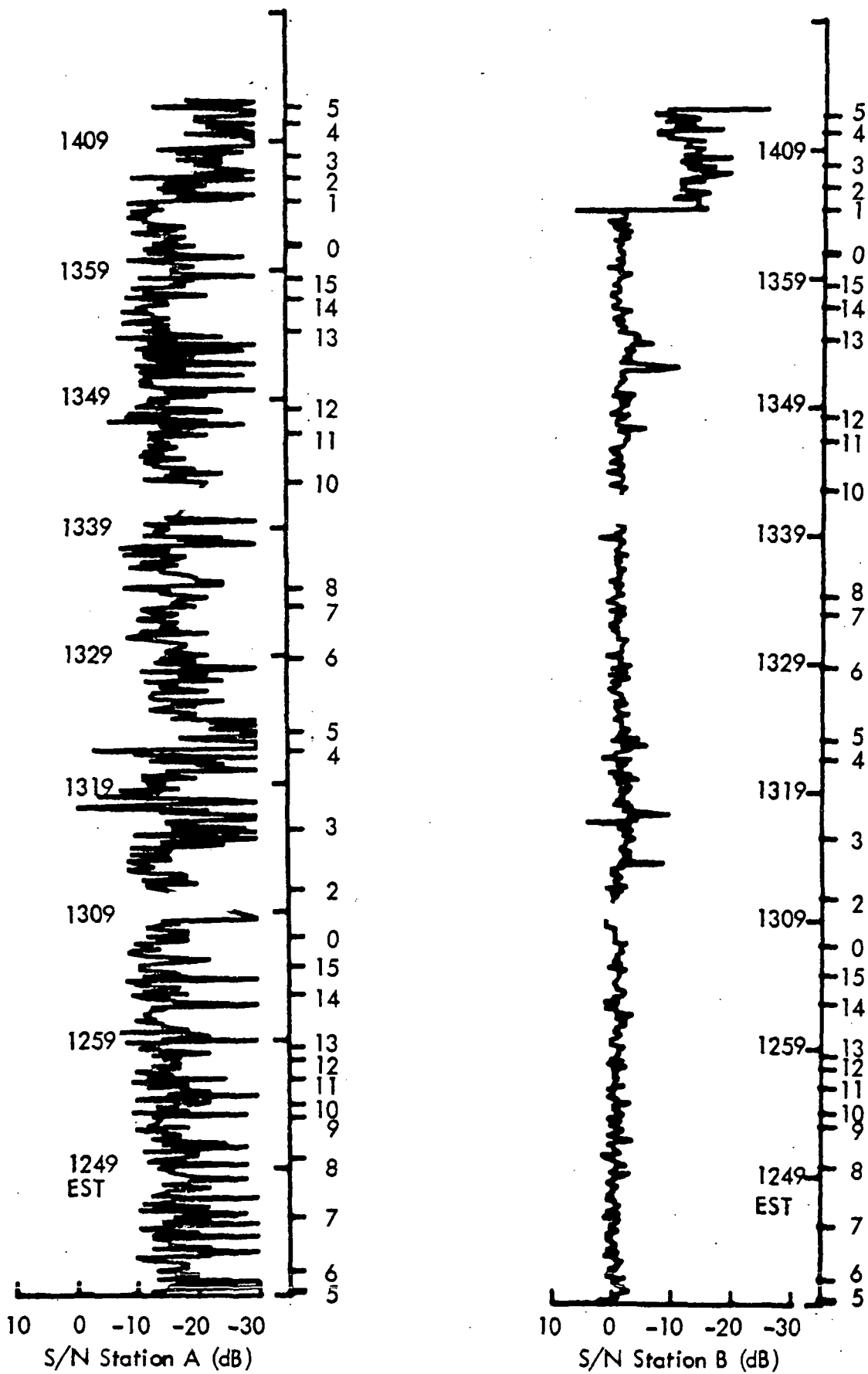

Figure B-36 . Flight 2-10 (Third 93 Min), S/N Station A and B;
 BED-College Park, 2/14/75, 2000', 1034-1413 EST, 1534-1913 GMT.

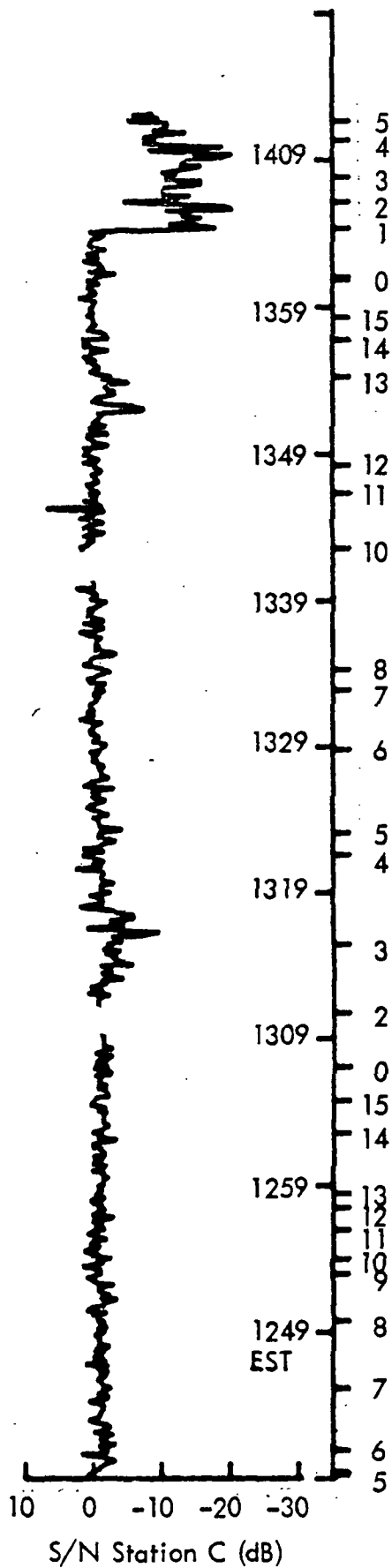

Figure B-37 . Flight 2-10 (Third 93 Min), S/N Station C;
 BED-College Park, 2/14/75, 2000', 1034-1413 EST, 1534-1913 GMT.

TEST DESCRIPTION

Flight No. 2-11

TEST OBJECTIVES: Provide S/N data during precipitation. Investigation of terrain effect of southern Catskills and Berkshires.

DATE: 2/17/75

DEPARTURE: IAD, 1621 EST

DESTINATION: BED

ROUTE: IAD, MRB, LRP, LHY, PWL, BED

ALTITUDE: 7000'

WEATHER: IFR in varying light to heavy rain
some icing conditions

SUMMARY: Takeoff at IAD in light rain with one mile visibility. Waypoints were chosen along the expected IFR clearance route wherever VORs coincided with airports. Weak Station A S/N caused track loss. Receiver was reset over Honesdale Airport and again 6 miles south of Monticello Airport. This same offset bias was shown when landing at BED.

KEY WORDS: Suitability, altitude effects.

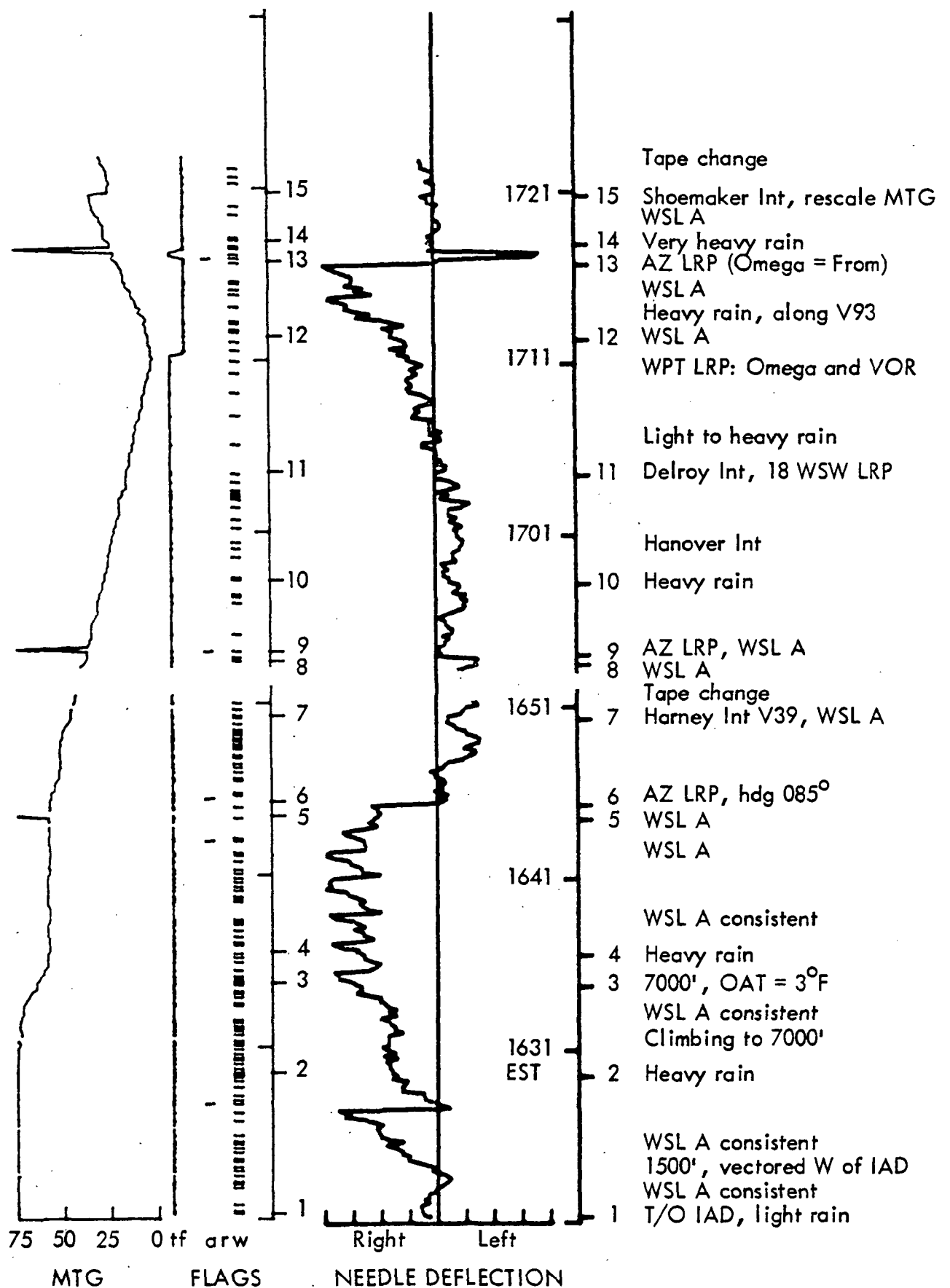

Figure B-38. Flight 2-11 (First 62 Min), Miles to Go and Needle Deflection; IAD-BED (IFR in Rain), 2/17/75, 7000', 1621-1931 EST, 2121-0031 GMT.

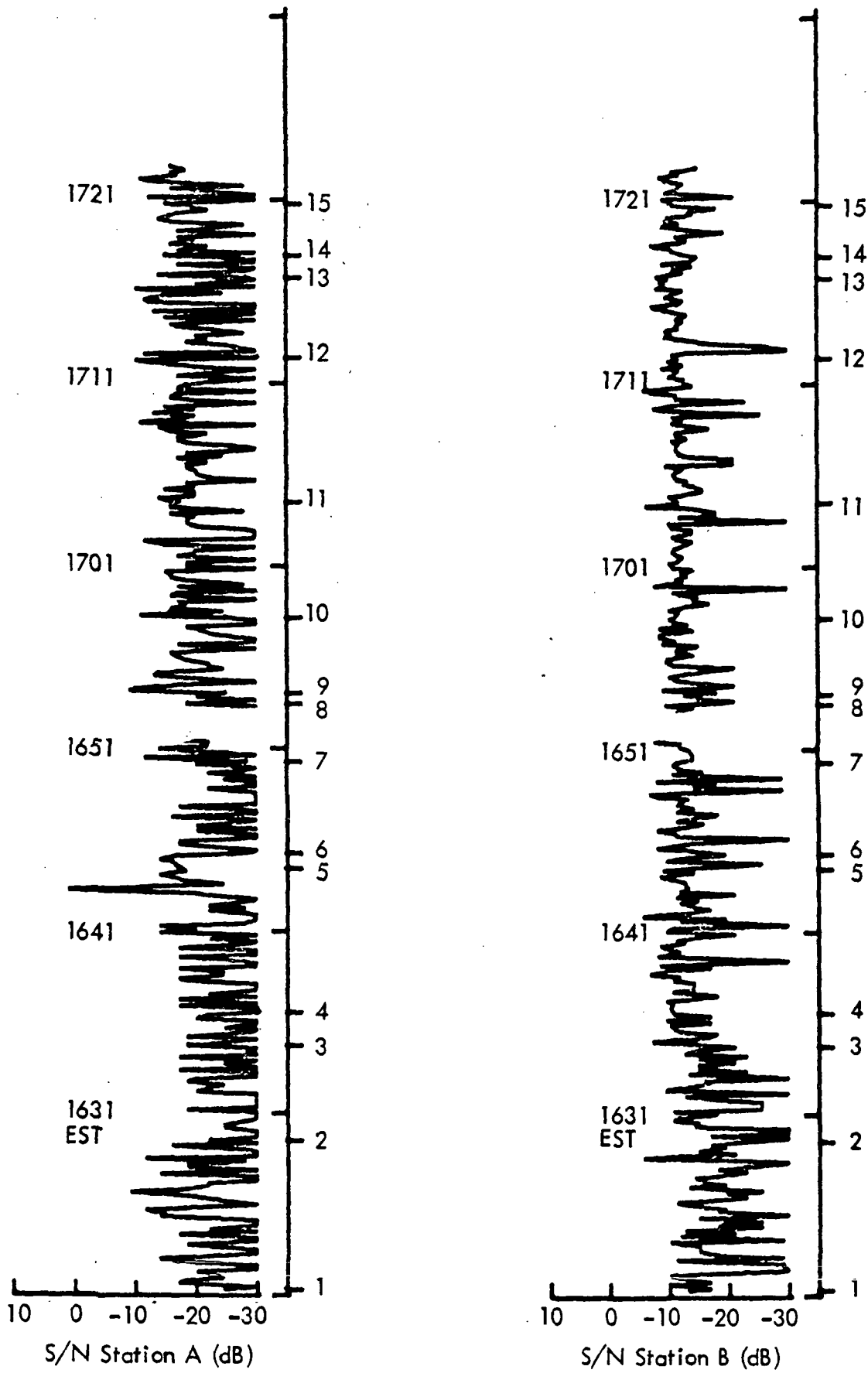

Figure B-39. Flight 2-11 (First 62 Min), S/N Station A and B; IAD-BED (IFR in Rain), 2/17/75, 7000', 1621-1931 EST, 2121-0031 GMT.

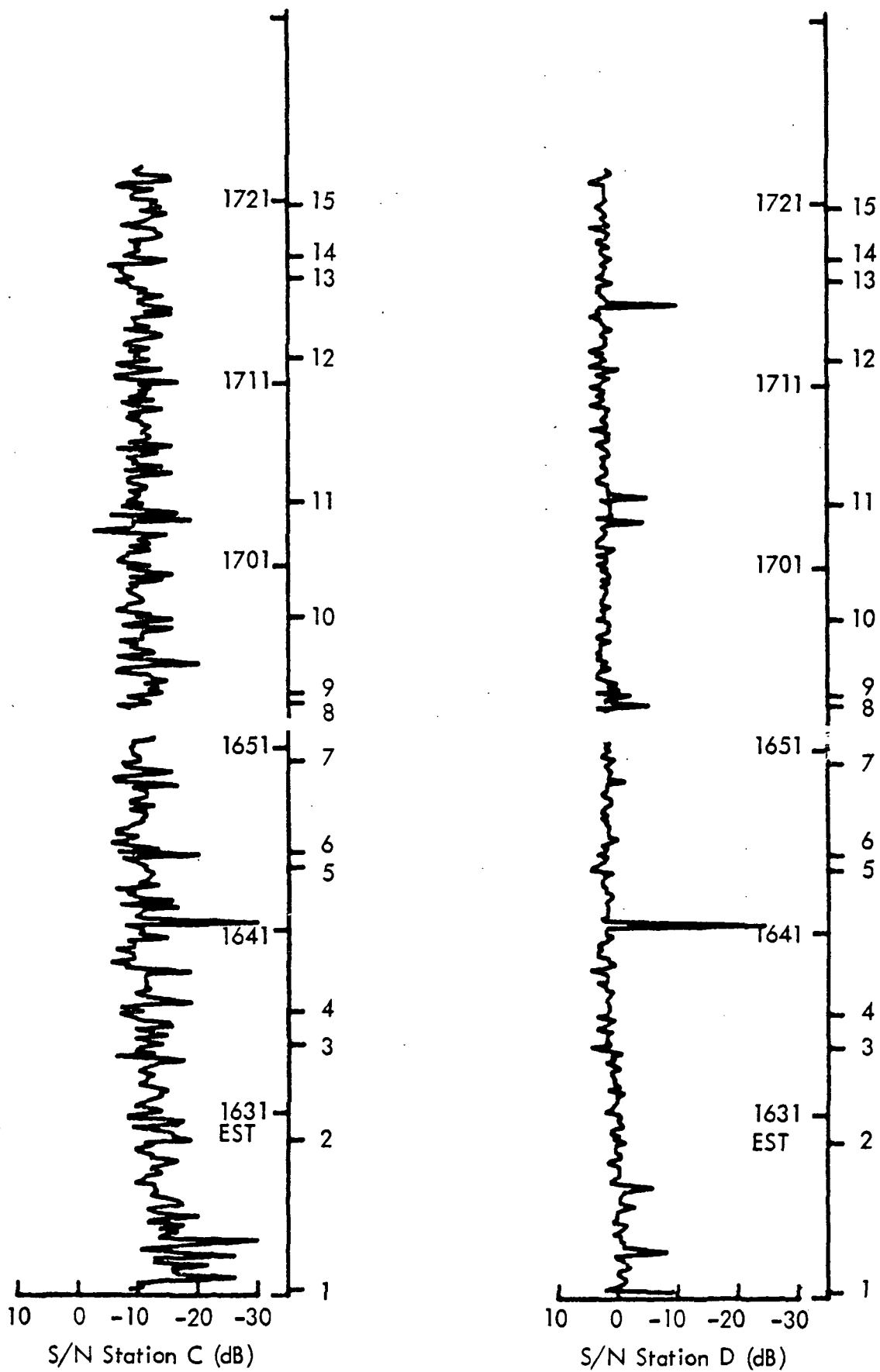

Figure B-40. Flight 2-11 (First 62 Min), S/N Station C and D; IAD-BED (IFR in Rain), 2/17/75, 7000', 1621-1931 EST, 2121-0031 GMT.

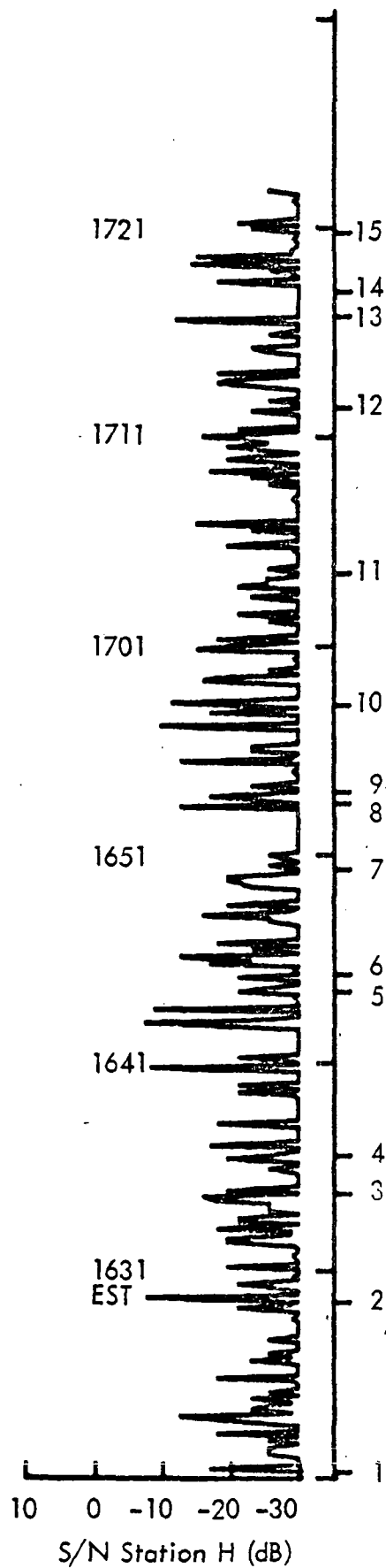

Figure B-41. Flight 2-11 (First 62 Min), S/N Station H;
 IAD-BED (IFR in Rain), 2/17/75, 7000', 1621-1931 EST, 2121-0031 GMT.

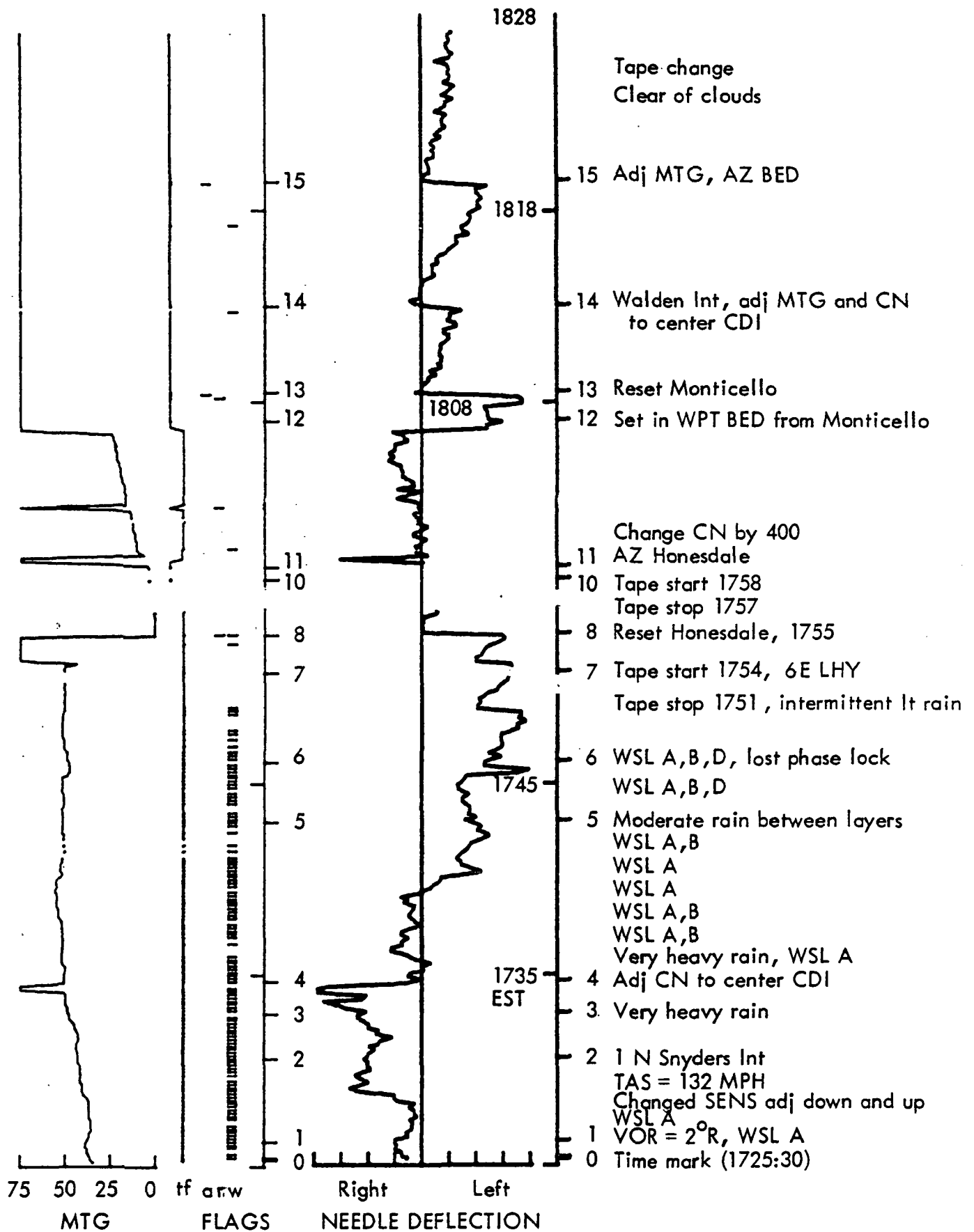

Figure B-42. Flight 2-11 (Second 61 Min), Miles to Go and Needle Deflection; IAD-BED (IFR in Rain), 2/17/75, 7000', 1621-1931 EST, 2121-0031 GMT.

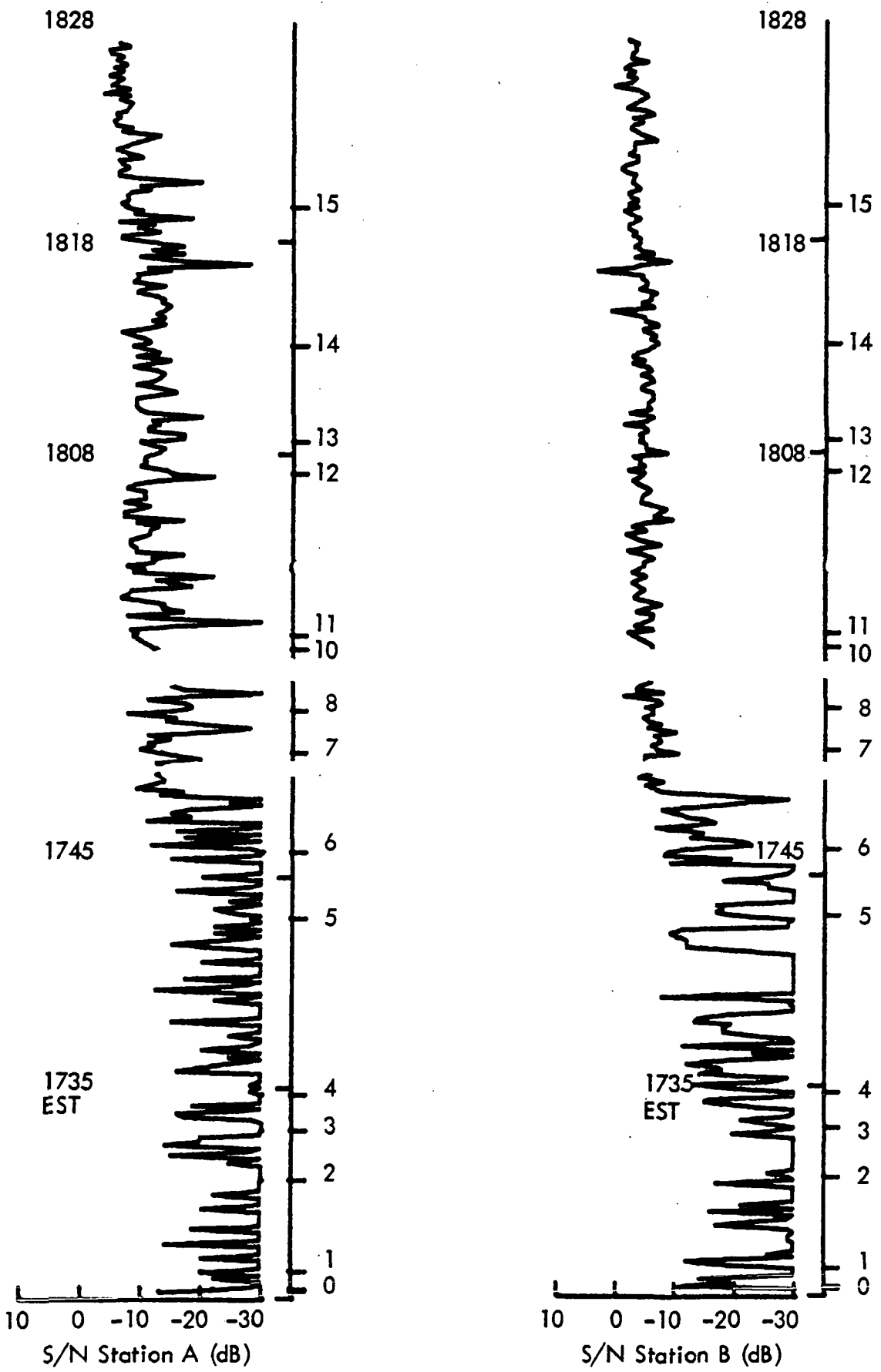

Figure B-43. Flight 2-11 (Second 61 Min), S/N Station A and B; IAD-BED (IFR in Rain), 2/17/75, 7000', 1621-1931 EST, 2121-0031 GMT.

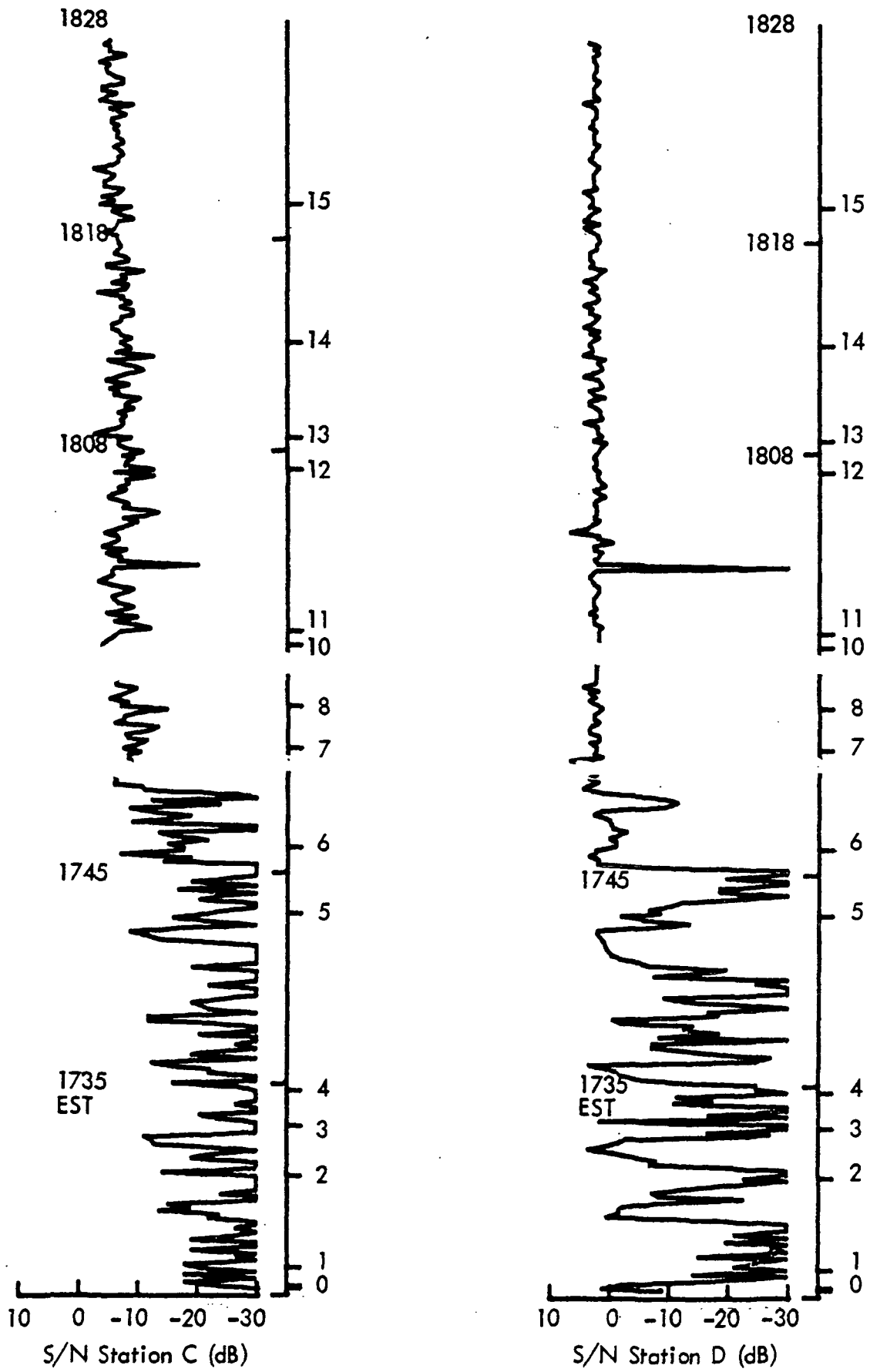

Figure B-44. Flight 2-11 (Second 61 Min), S/N Station C and D; IAD-BED (IFR in Rain), 2/17/75, 7000', 1621-1931 EST, 2121-0031 GMT.

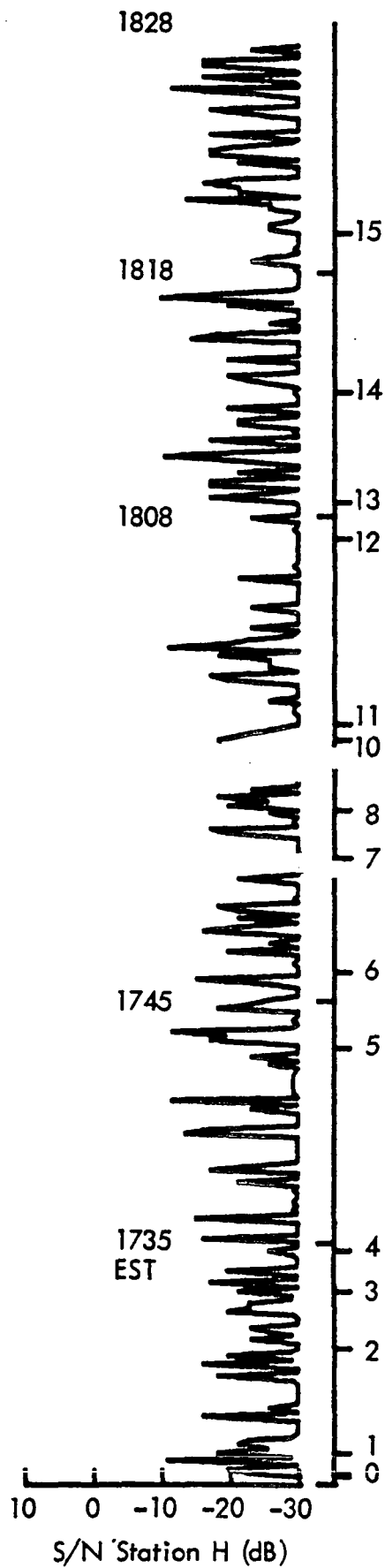

Figure B-45. Flight 2-11 (Second 61 Min), S/N Station H;
 IAD-BED (IFR in Rain), 2/17/75, 7000', 1621-1931 EST, 2121-0031 GMT.

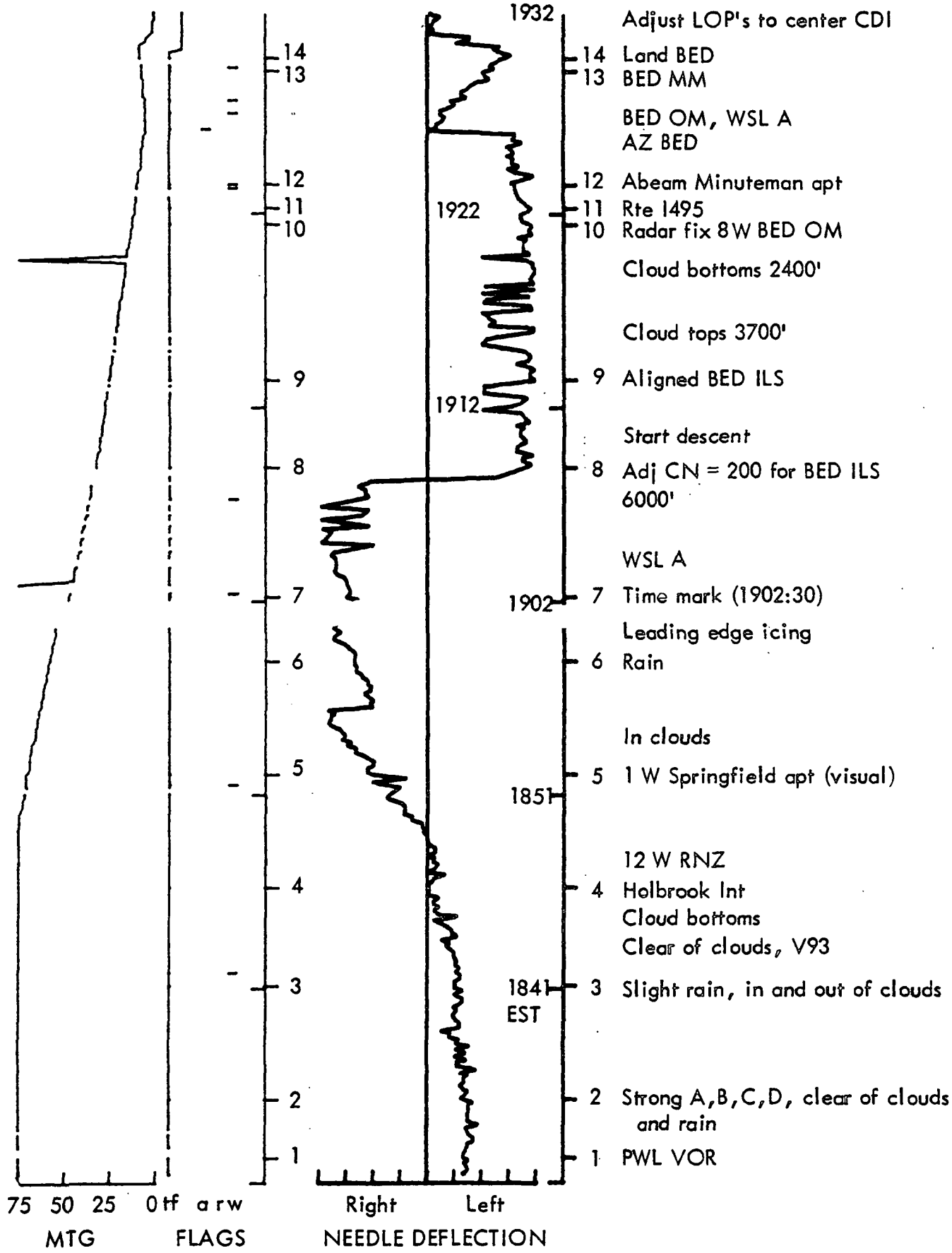

Figure B-46. Flight 2-11 (Third 61 Min), Miles to Go and Needle Deflection; IAD-BED (IFR in Rain), 2/17/75, 7000', 1621-1931 EST, 2121-0031 GMT.

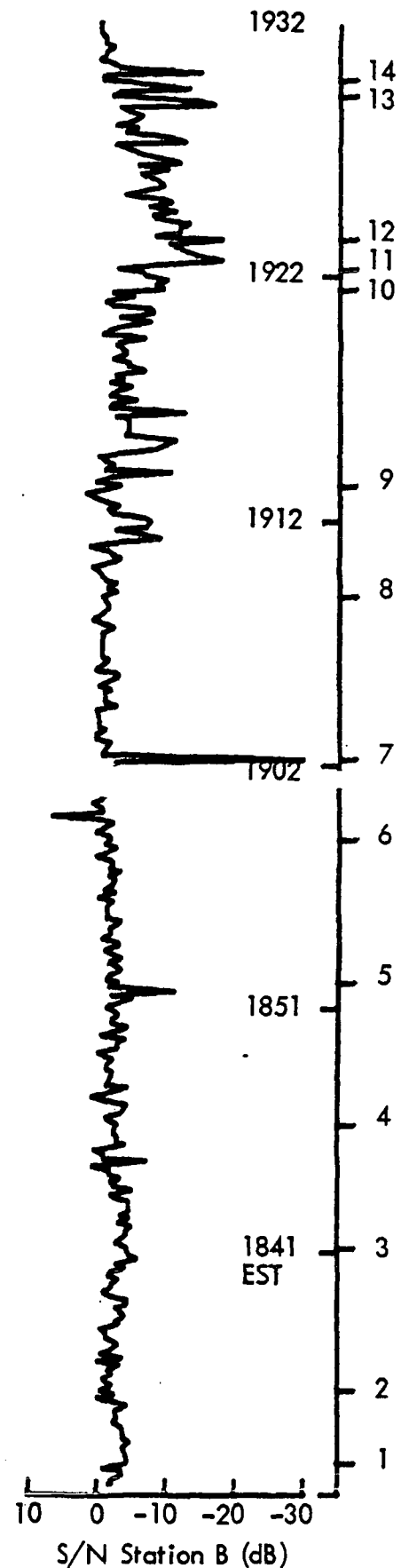
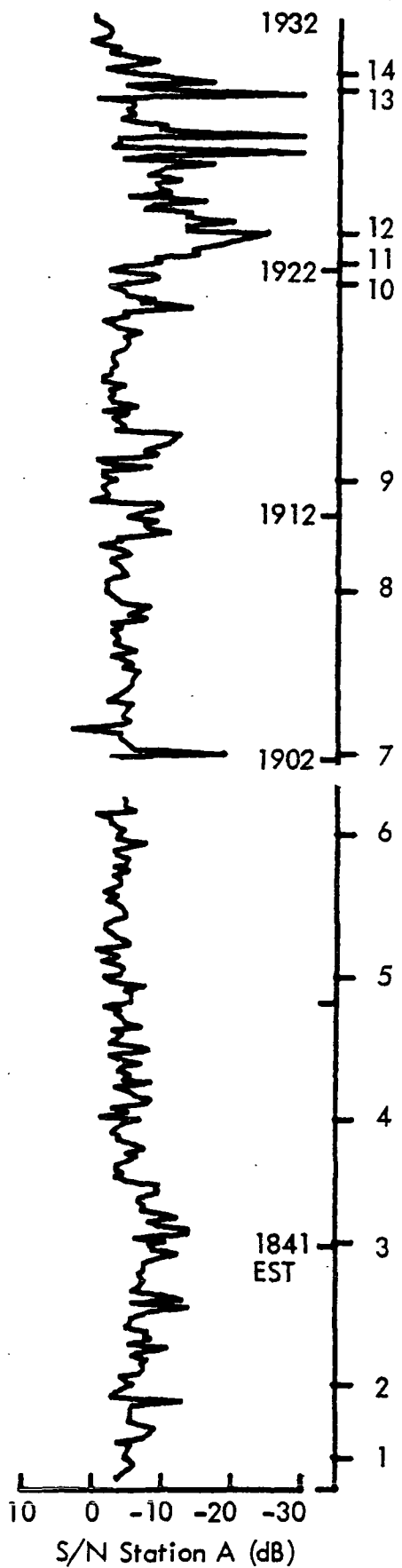

Figure B-47. Flight 2-11 (Third 61 Min), S/N Station A and B; IAD-BED (IFR in Rain), 2/17/75, 7000', 1621-1931 EST, 2121-0031 GMT.

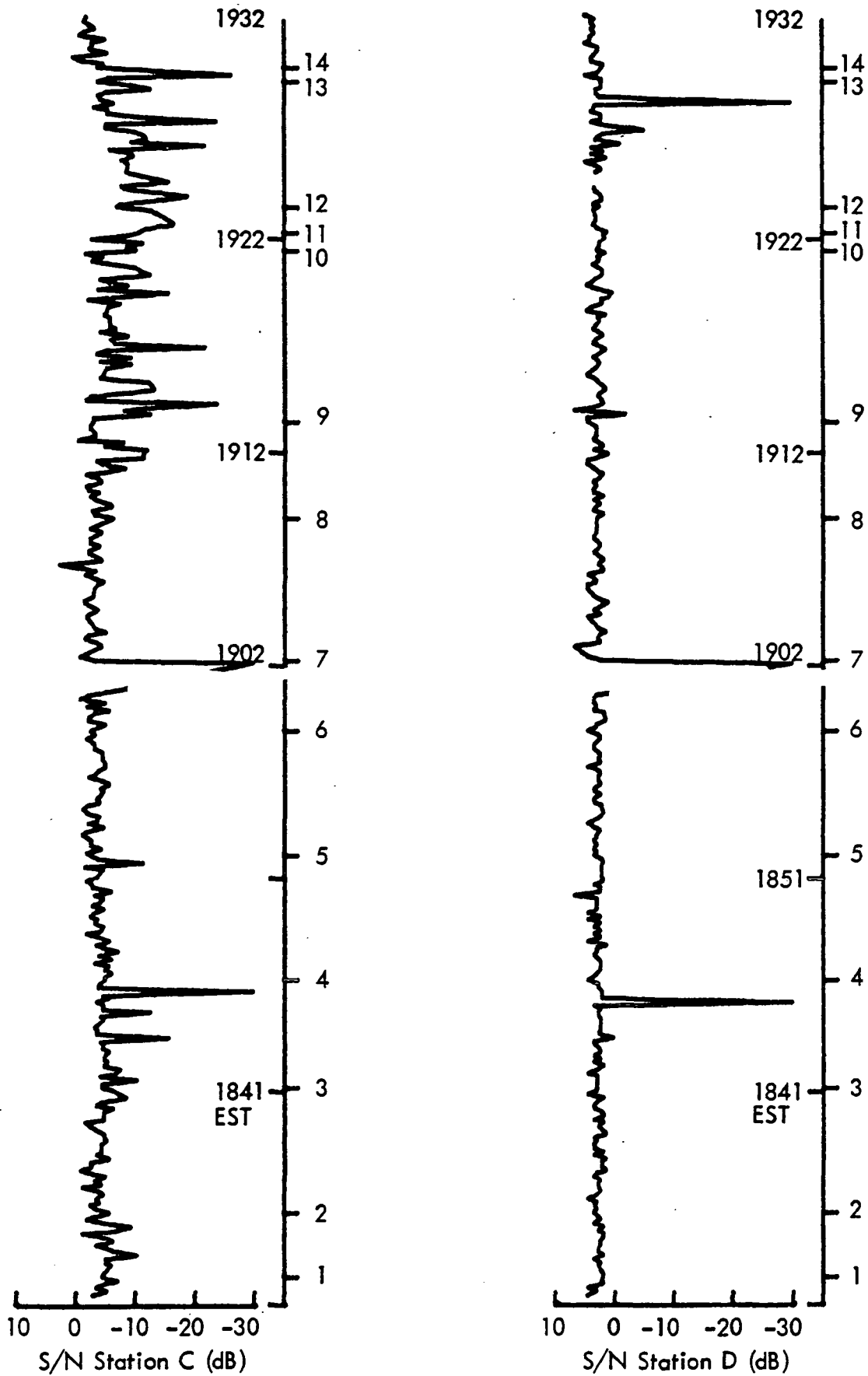

Figure B-48. Flight 2-11 (Third 61 Min), S/N Station C and D; IAD-BED (IFR in Rain), 2/17/75, 7000', 1621-1931 EST, 2121-0031 GMT.

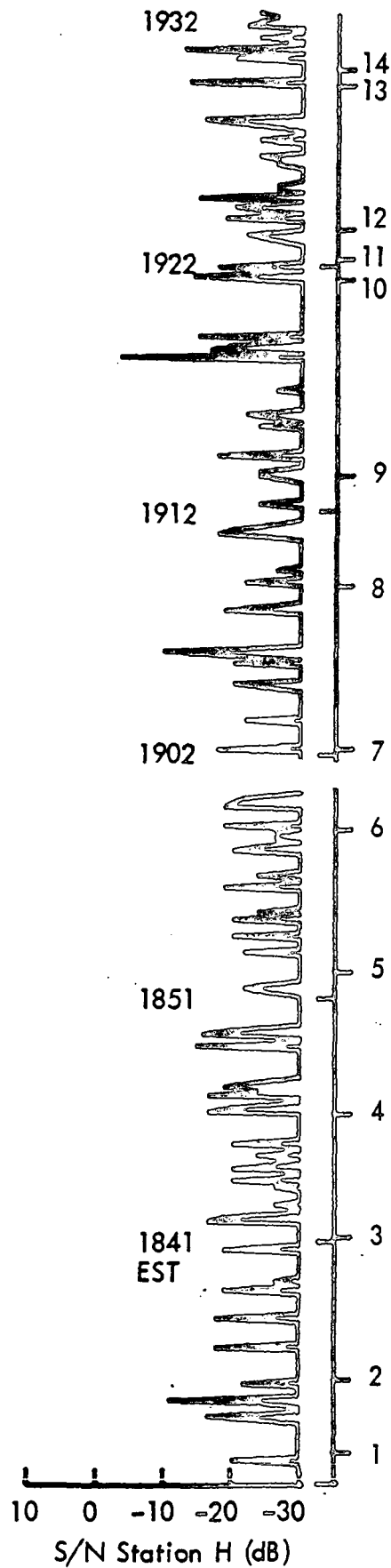

Figure B-49. Flight 2-11 (Third 61 Min), S/N Station H;
IAD-BED (IFR in Rain), 2/17/75, 7000', 1621-1931 EST, 2121-0031 GMT.

TEST DESCRIPTION

Flight No. 2-12

TEST OBJECTIVES: Obtain additional S/N data along Zulu routes before diverting to SBY.

DATE: 2/19/75

DEPARTURE: BED, 1210 EST

DESTINATION: SBY

ROUTE: Zulu-2, Zulu-S, divert SBY

ALTITUDE: 2000', 1100' under
NY TCA

WEATHER: VFR, 15 kts SW

SUMMARY: Flight proceeded as planned, with radios off for the majority of the flight.

KEY WORDS: Suitability, altitude effects, terrain effects

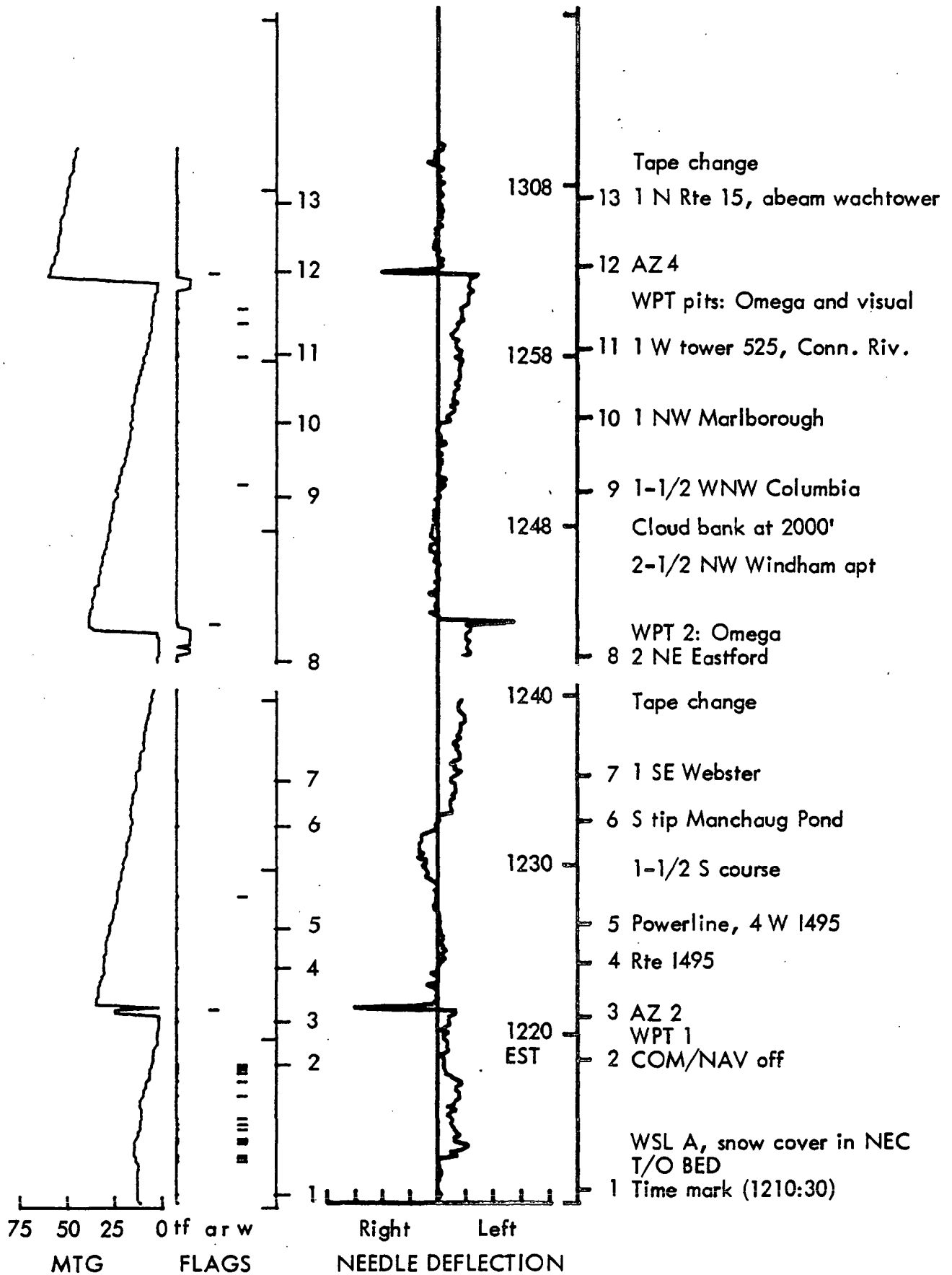

Figure B-50. Flight 2-12 (First 61 Min), Miles to Go and Needle Deflection;
 BED-SBY (Z2, ZS) 2/19/75, 2000', 1210-1530 EST, 1710-2030 GMT.

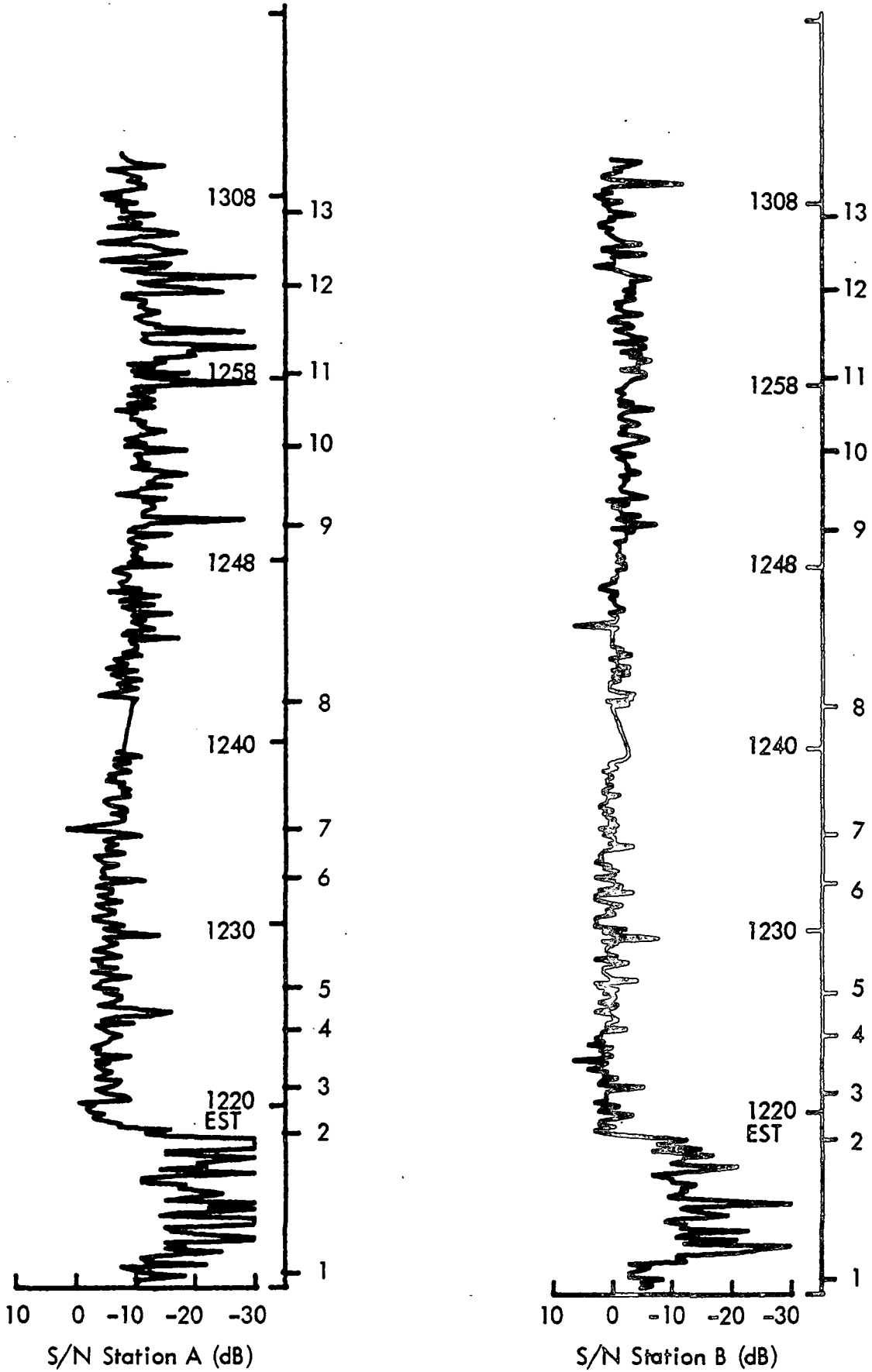

Figure B-51. Flight 2-12 (First 61 Min), S/N Station A and B; BED-SBY (Z2, ZS) 2/19/75, 2000', 1210-1530 EST, 1710-2030 GMT.

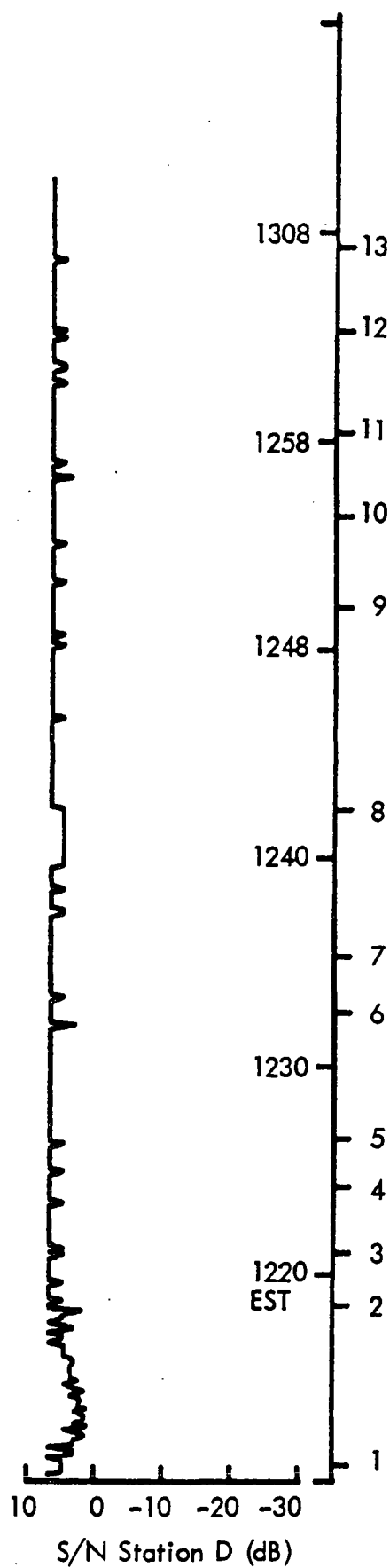
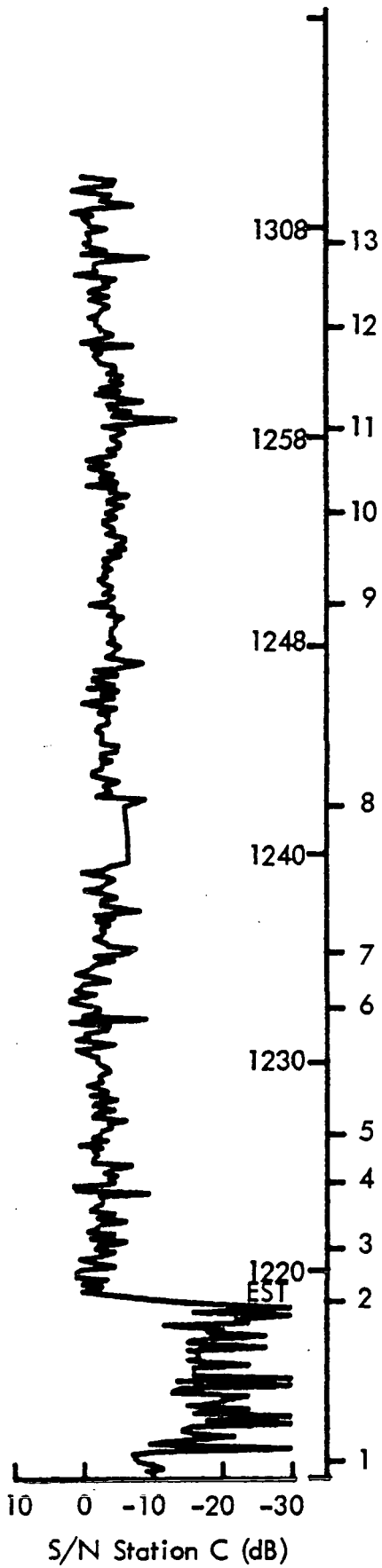

Figure B-52 . Flight 2-12 (First 61 Min), S/N Station C and D;
 BED-SBY (Z2, ZS) 2/19/75, 2000', 1210-1530 EST, 1710-2030 GMT.

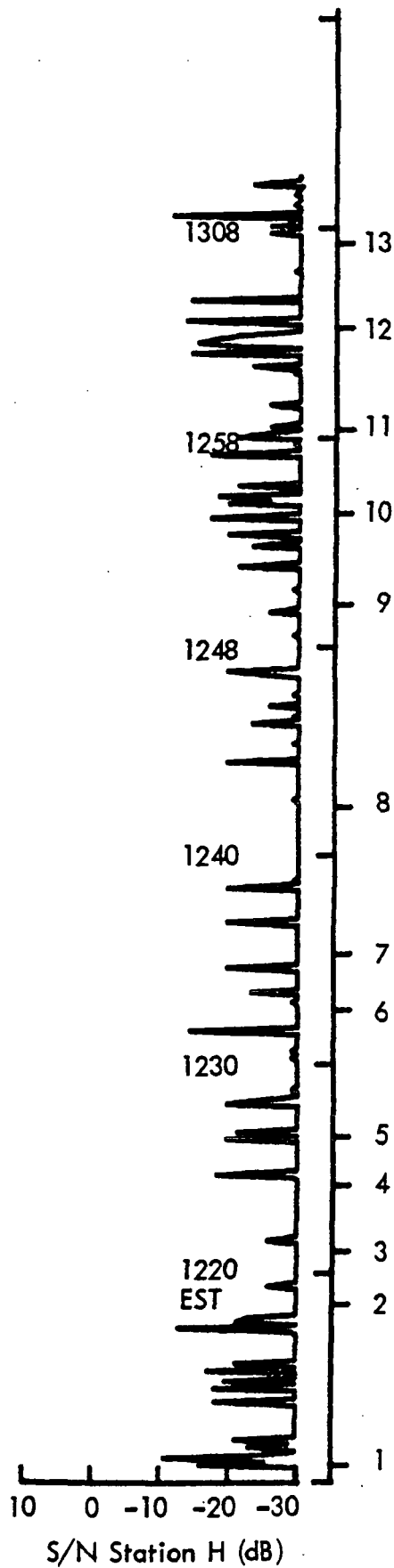

Figure B-53 . Flight 2-12 (First 61 Min), S/N Station H;
 BED-SBY (Z2, Z5) 2/19/75, 2000', 1210-1530 EST, 1710-2030 GMT.

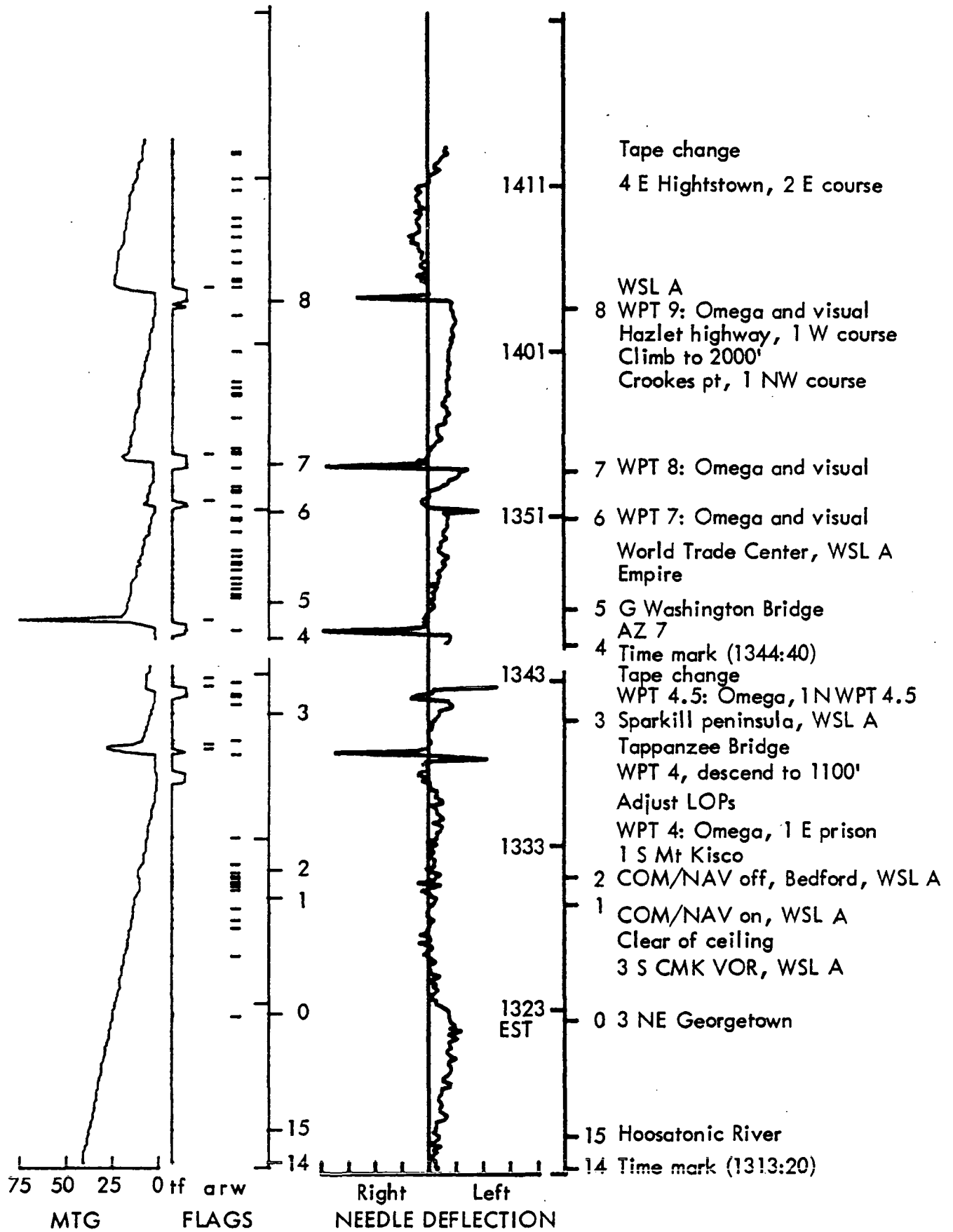

Figure B-54. Flight 2-12 (Second 60 Min), Miles to Go and Needle Deflection;
 BED-SBY (Z2, ZS) 2/19/75, 2000', 1210-1530 EST, 1710-2030 GMT.

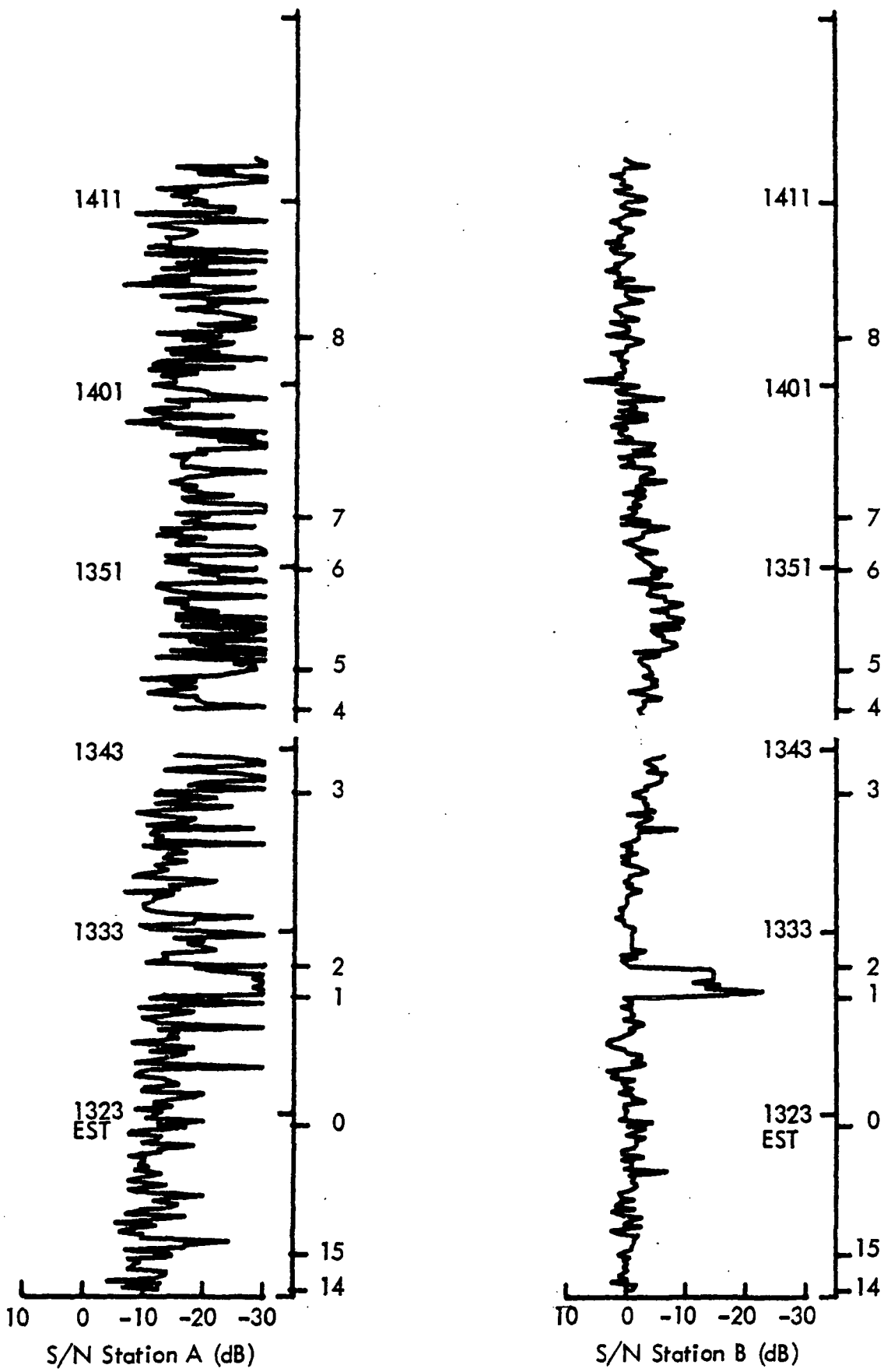

Figure B-55 . Flight 2-12 (Second 60 Min), S/N Station A and B;
 BED-SBY (Z2, ZS) 2/19/75, 2000', 1210-1530 EST, 1710-2030 GMT.

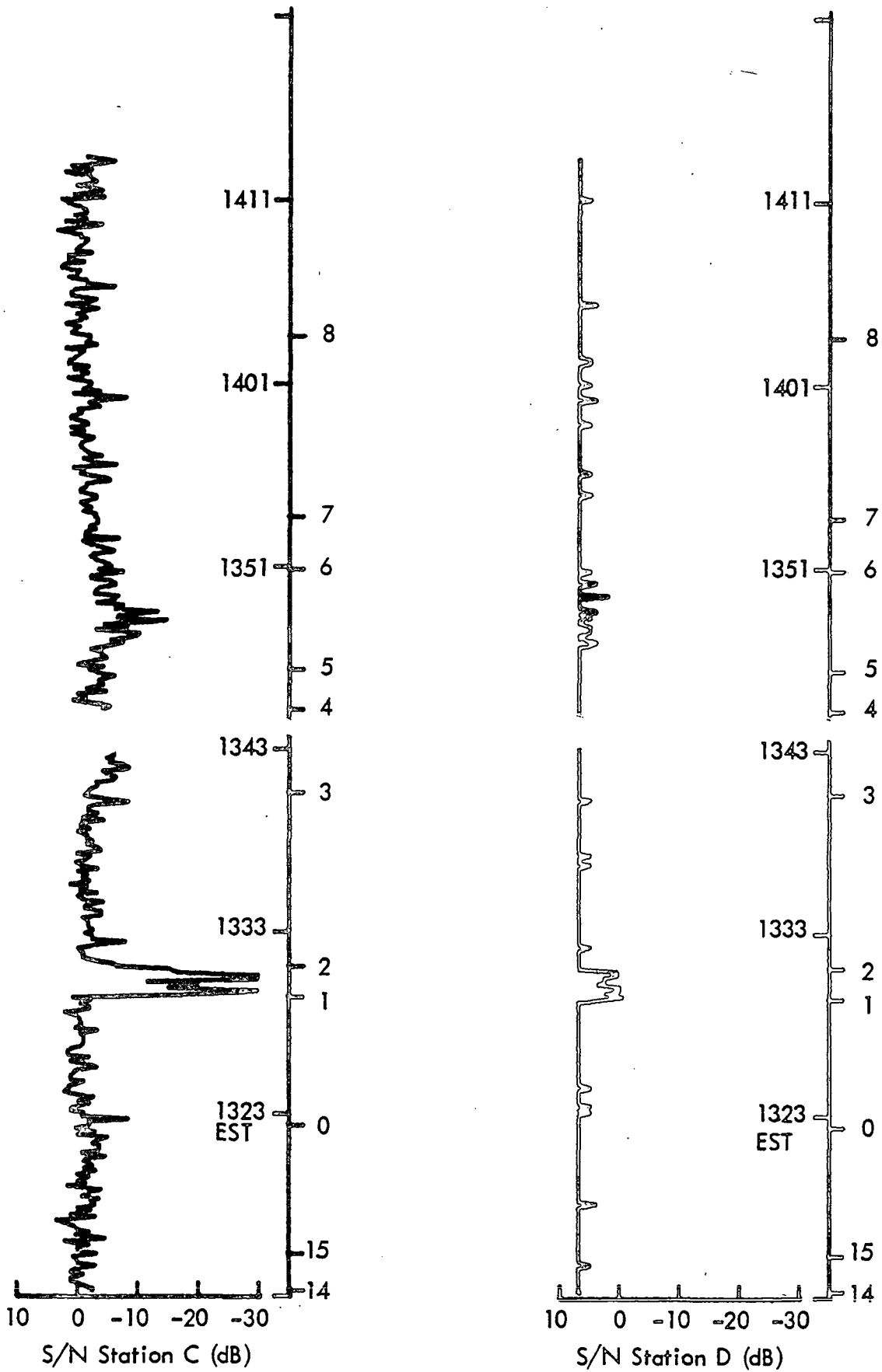

Figure B-56 . Flight 2-12 (Second 60 Min), S/N Station C and D;
 BED-SBY (Z2, ZS) 2/19/75, 2000', 1210-1530 EST, 1710-2030 GMT.

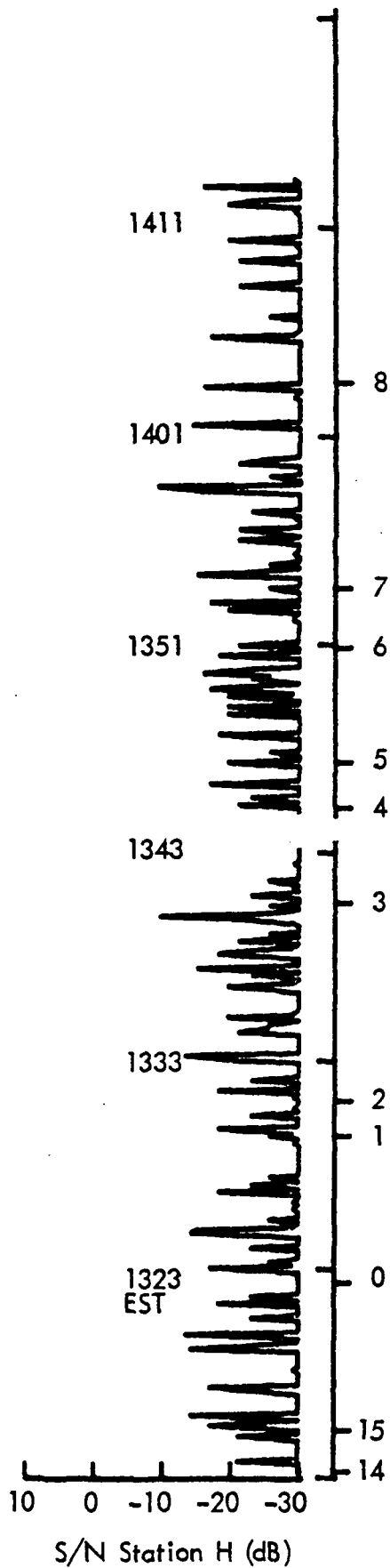

Figure B-57 . Flight 2-12 (Second 60 Min), S/N Station H;
 BED-SBY (Z2, ZS) 2/19/75, 2000', 1210-1530 EST, 1710-2030 GMT.

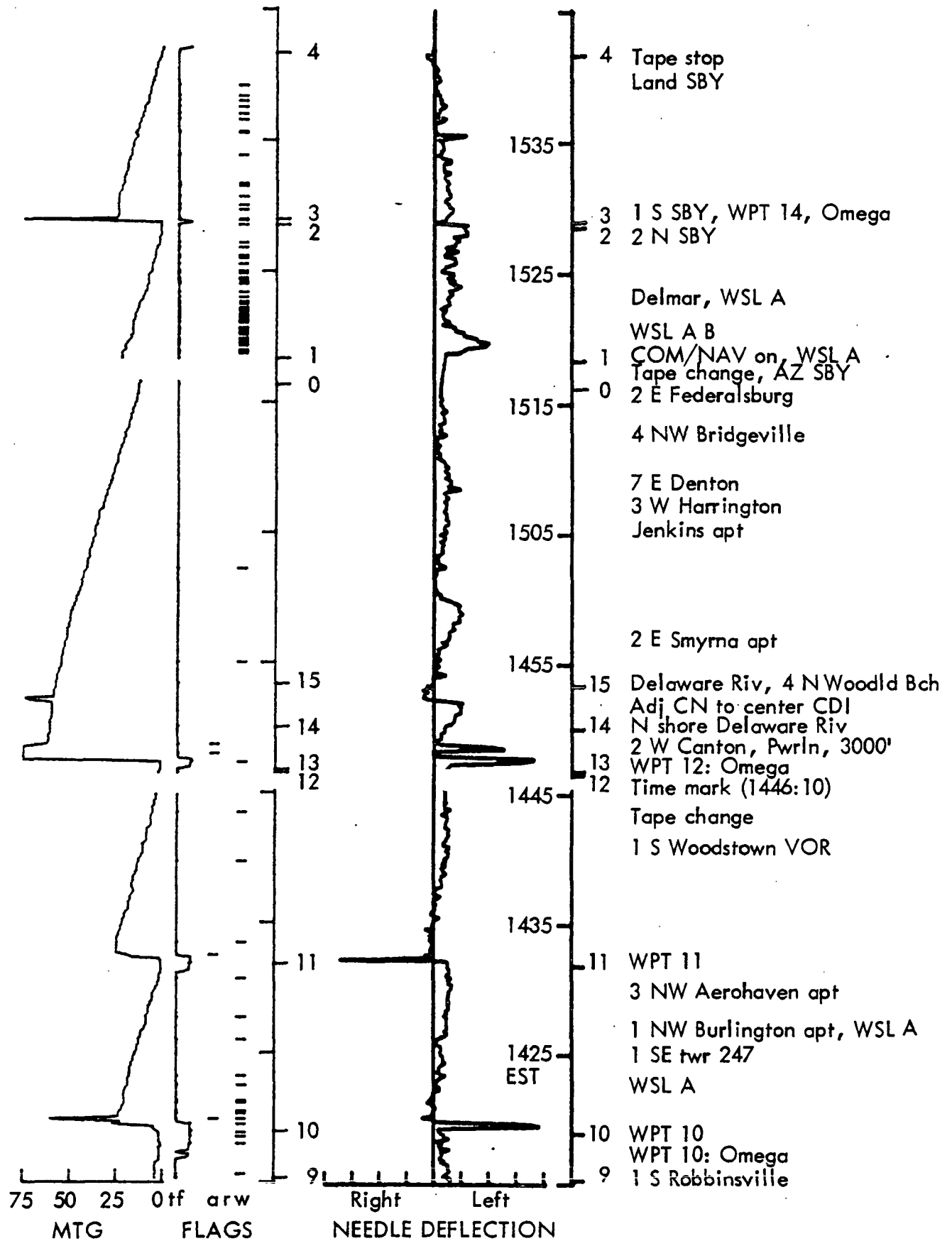

Figure B-58 . Flight 2-12 (Third 87 Min), Miles to Go and Needle Deflection;
BED-SBY (Z2, ZS) 2/19/75, 2000', 1210-1530 EST, 1710-2030 GMT.

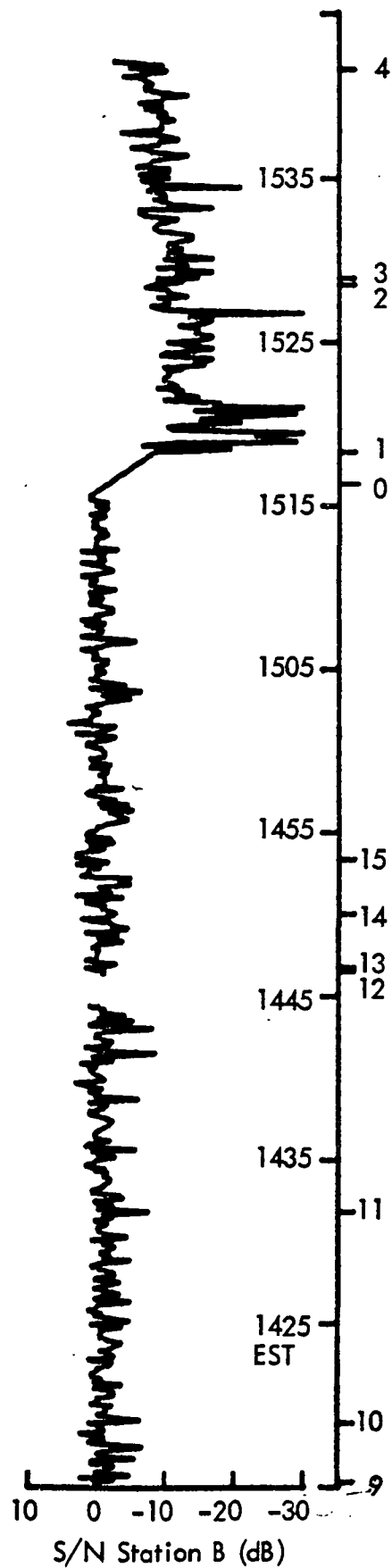
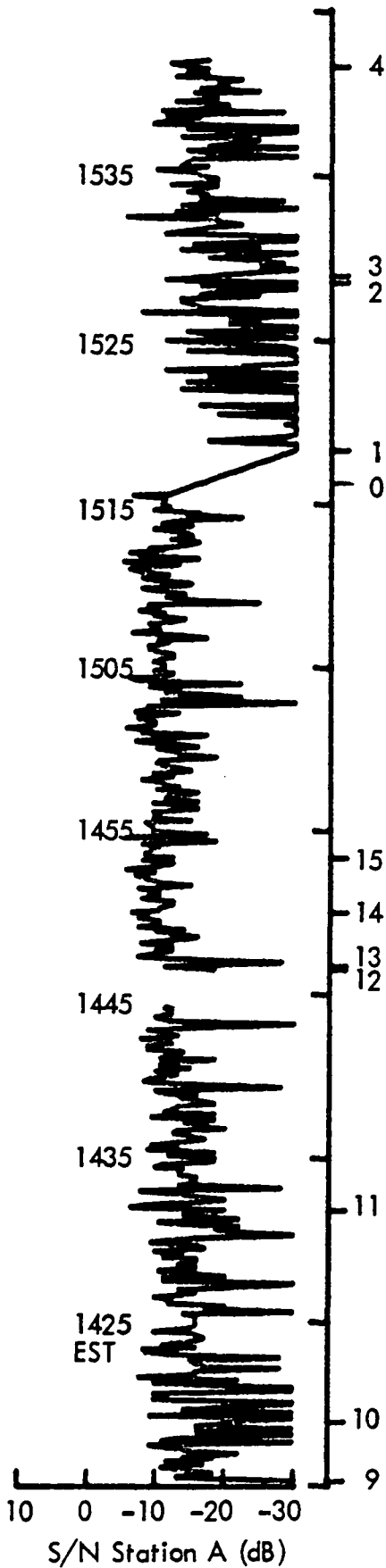

Figure B-59 . Flight 2-12 (Third 87 Min), S/N Station A and B;
 BED-SBY (Z2, ZS) 2/19/75, 2000', 1210-1530 EST, 1710-2030 GMT.

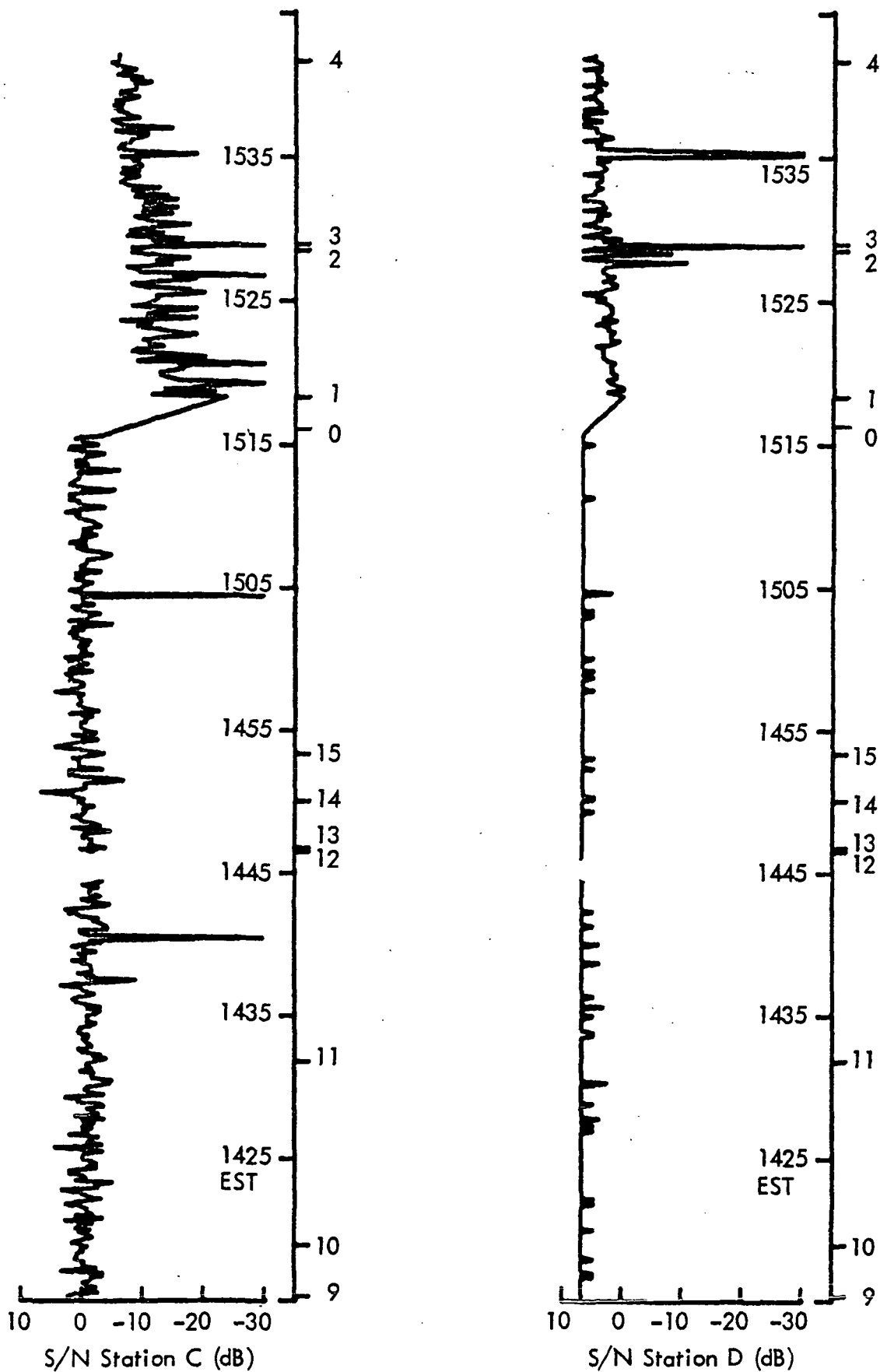

Figure B-60. Flight 2-12 (Third 87 Min), S/N Station C and D; BED-SBY (Z2, ZS) 2/19/75, 2000', 1210-1530 EST, 1710-2030 GMT.

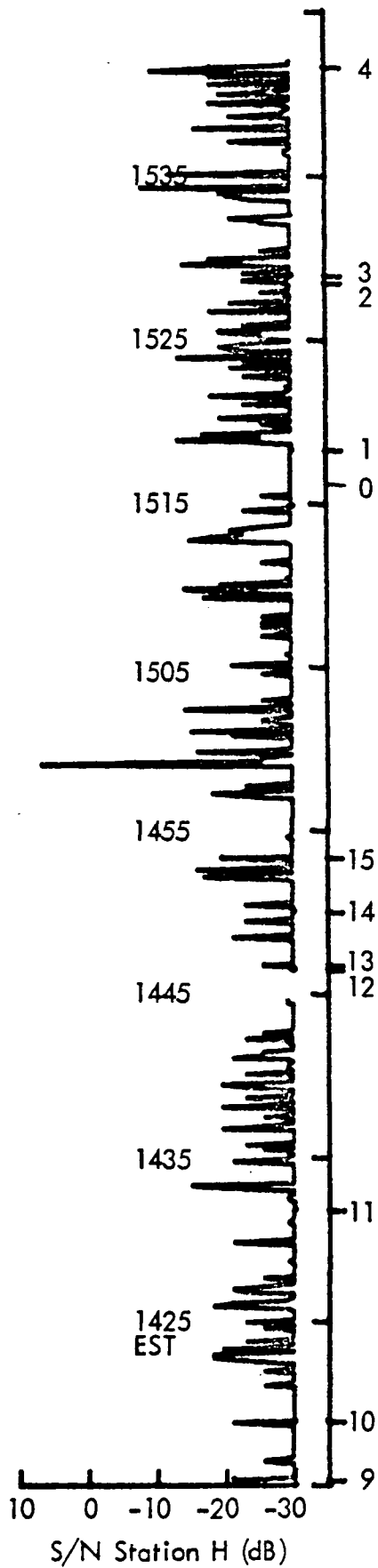

Figure B-61. Flight 2-12 (Third 87 Min), S/N Station H;
 BED-SBY (Z2, ZS) 2/19/75, 2000', 1210-1530 EST, 1710-2030 GMT.

TEST DESCRIPTION

Flight No. 2-13

TEST OBJECTIVES: Provide S/N data and waypoint accuracy check enroute from SBY to BED via airports and along the Z-1 route.

DATE: 2/22/75 DEPARTURE: SBY, 1230 EST

DESTINATION: BED ROUTE: Z-1

ALTITUDE: 5500', 500' under WEATHER: VFR, 15 kts SW
NY TCA

SUMMARY: Voice tape discovered inoperative over Long Island. Miles to go stopped decreasing over Connecticut (analysis showed strong S/N ratios). Later in the flight the MTG began to increment properly again.

KEY WORDS: Suitability, altitude effects, terrain effects

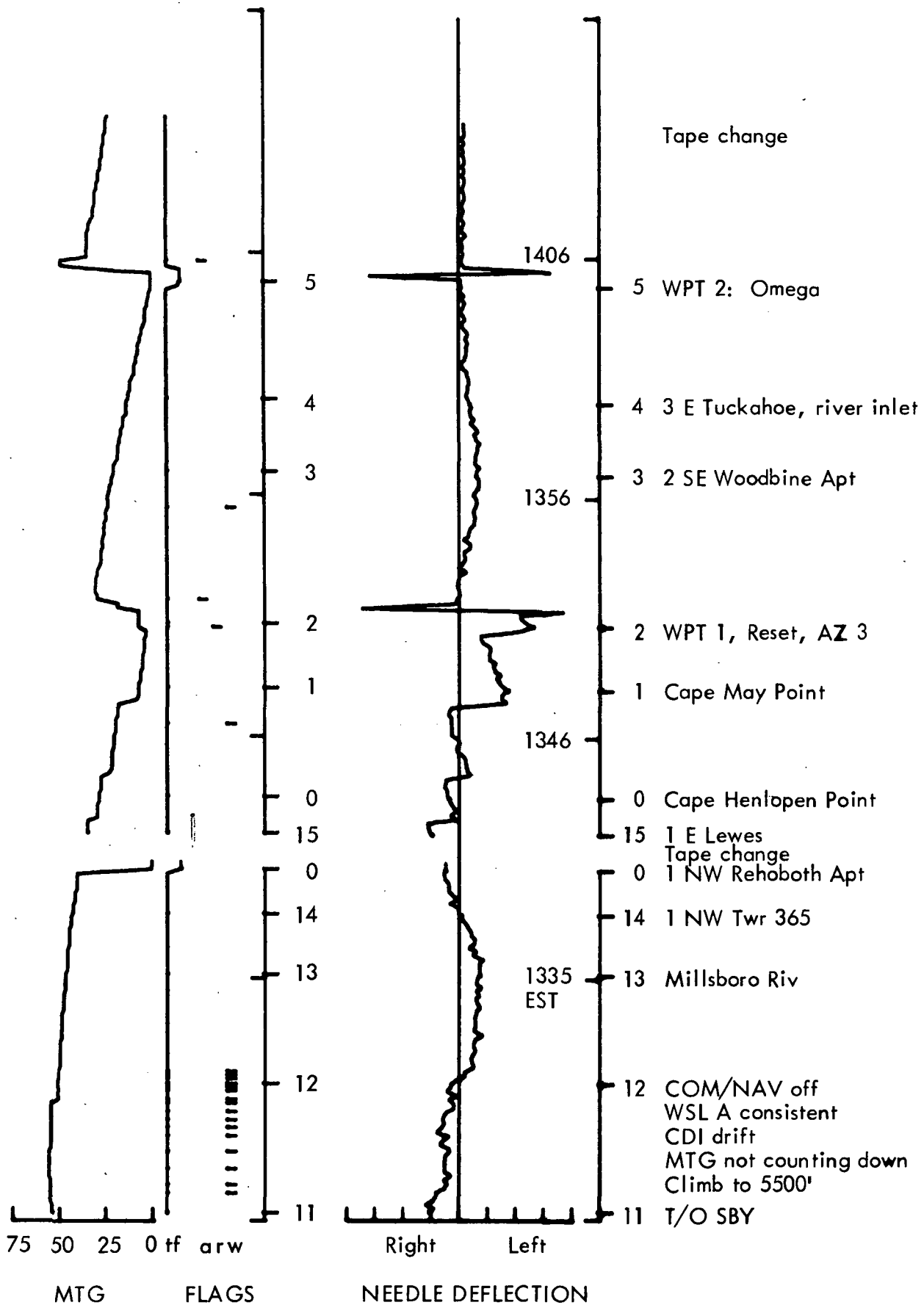

Figure B-62 . Flight 2-13 (First 47 min.), Miles to Go and Needle Deflection;
SBY-BED (Z1), 2/22/75, 5500', 1225-1608 EST, 1725-2108 GMT.

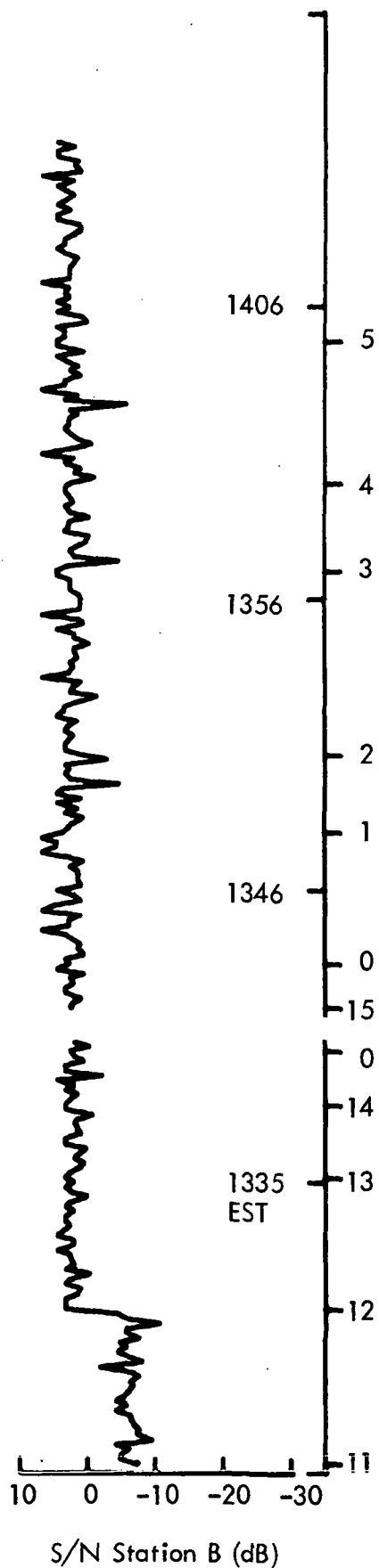
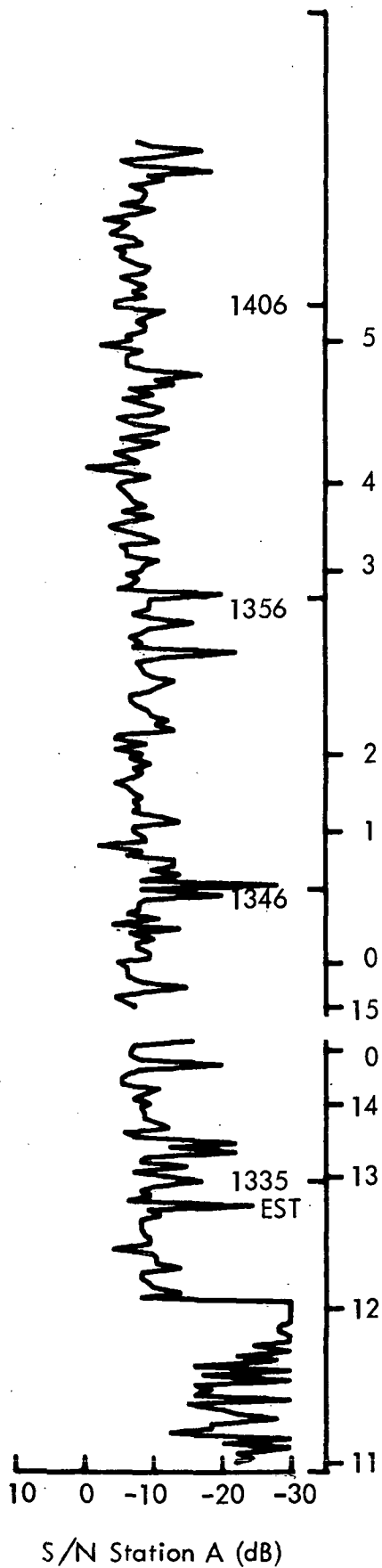

Figure B-63 . Flight 2-13 (First 47 min.), S/N Station A and B;
 SBY-BED (Z1), 2/22/75, 5500', 1225-1608 EST, 1725-2108 GMT.

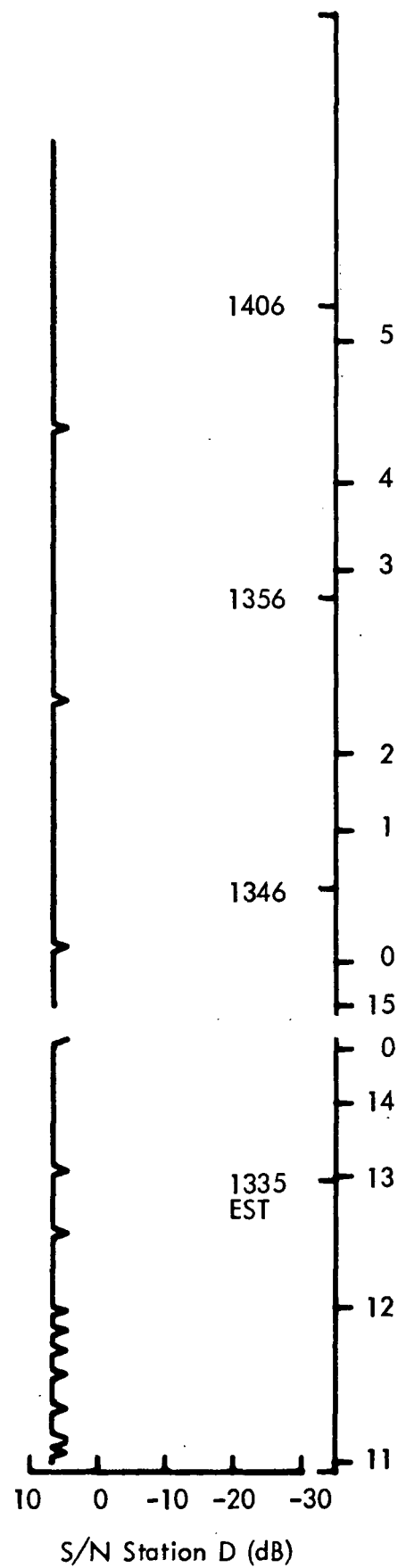
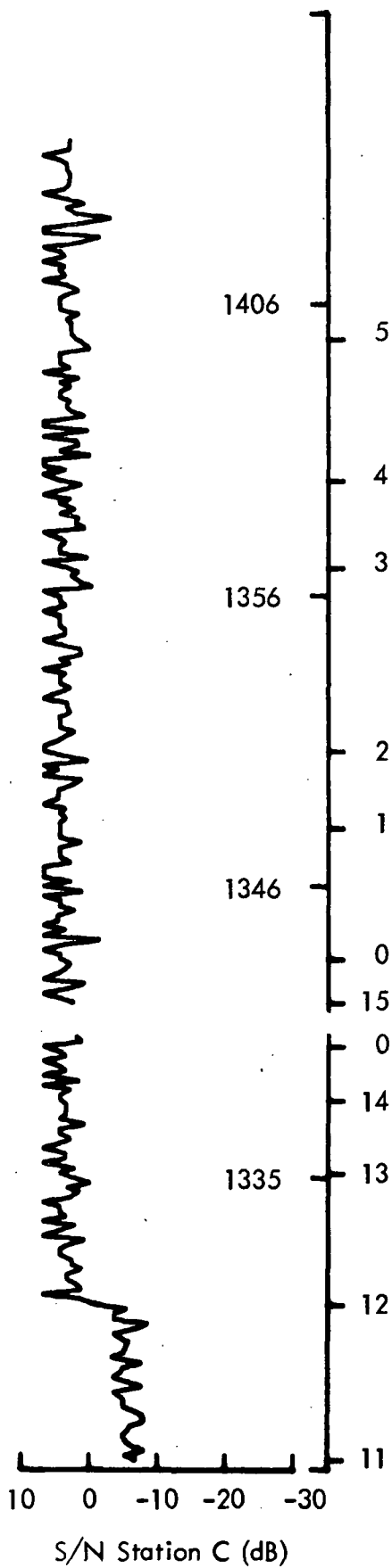

Figure B-64. Flight 2-13 (First 47 min.), S/N Station C and D; SBY-BED (Z1), 2/22/75, 5500', 1225-1608 EST, 1725-2108 GMT.

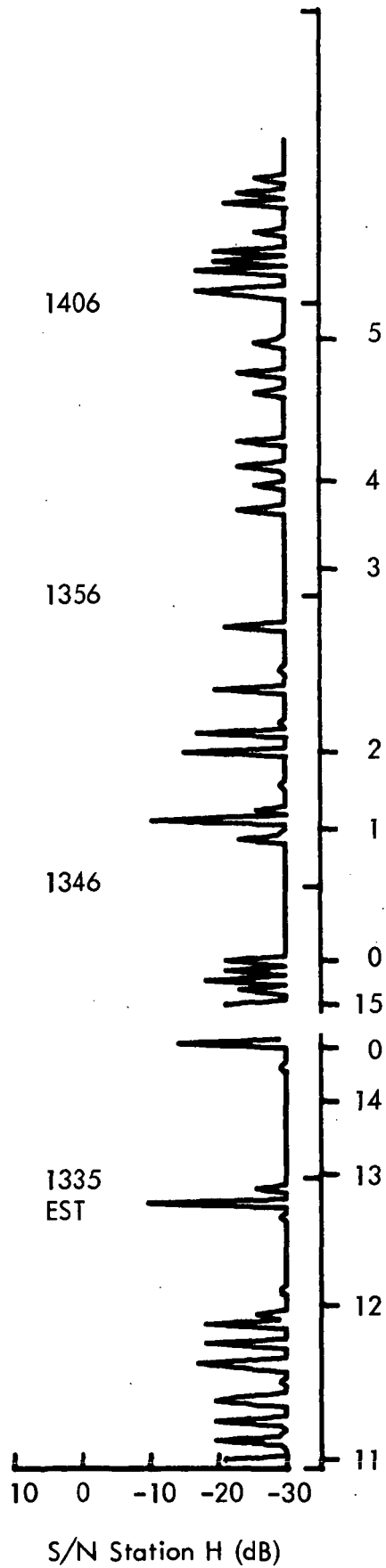

Figure B-65 . Flight 2-13 (First 47 min.), S/N Station H;
 SBY-BED (Z1), 2/22/75, 5500', 1225-1608 EST, 1725-2108 GMT.

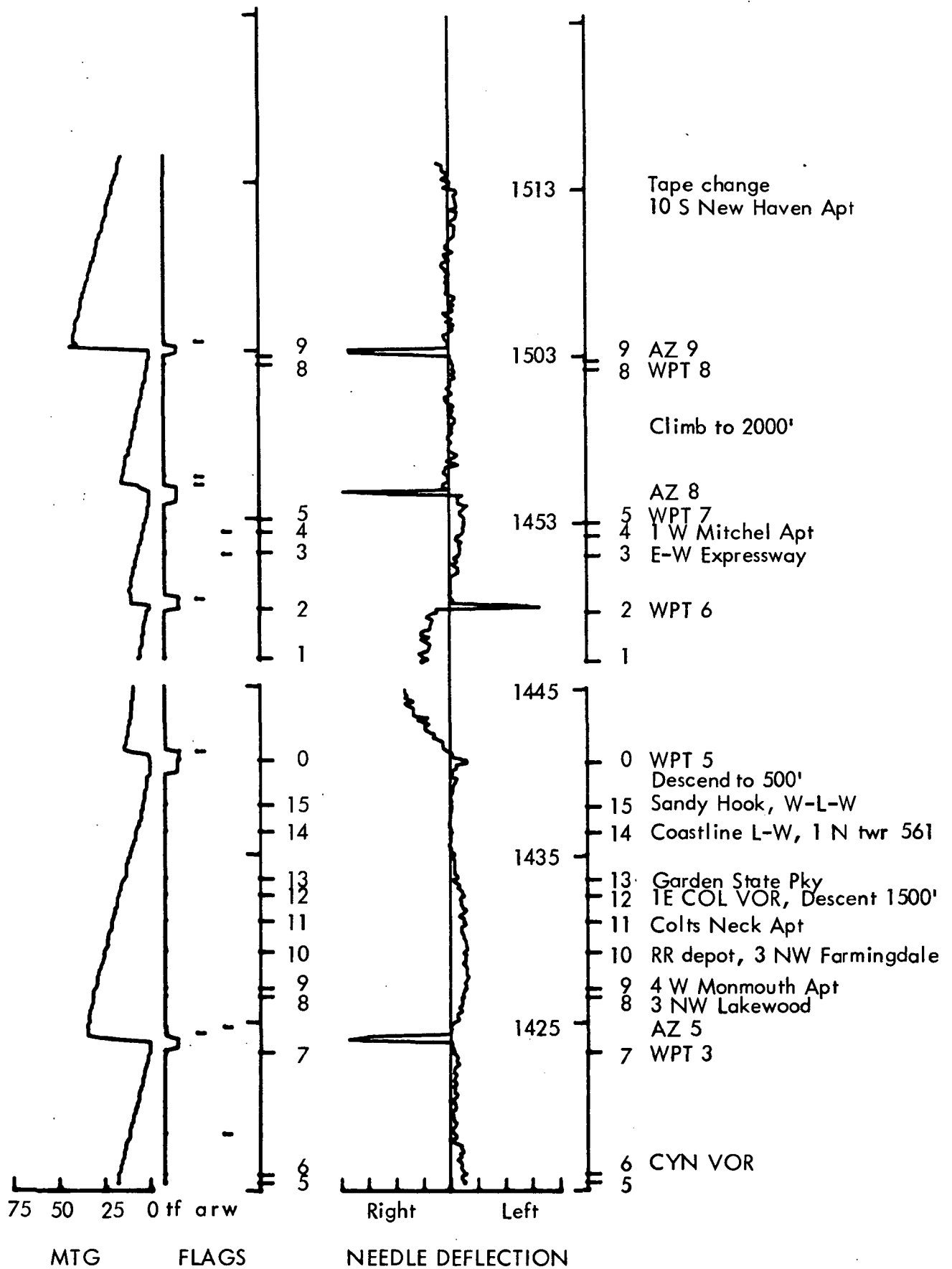
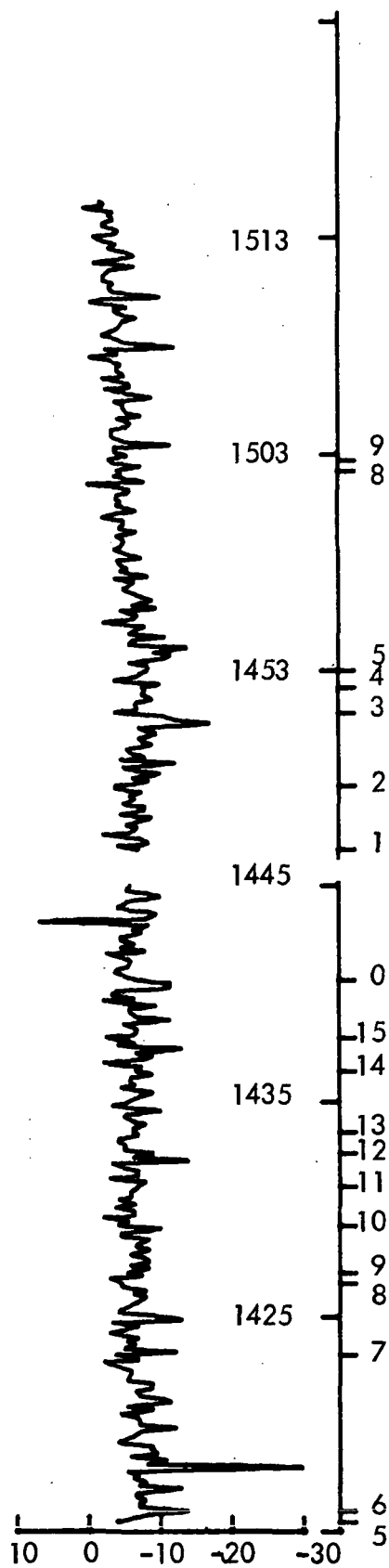
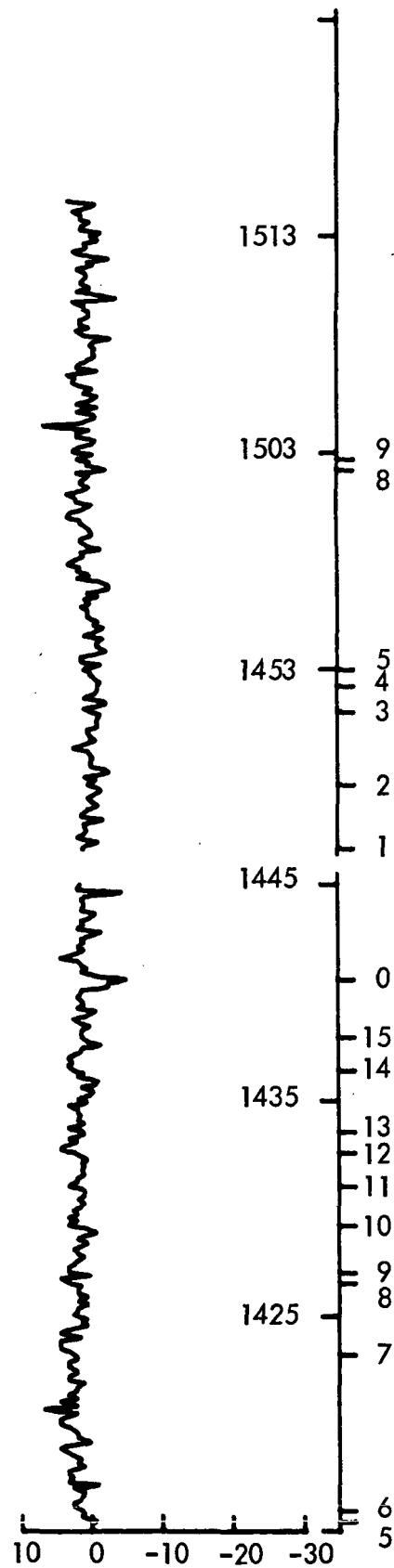

Figure B-66 . Flight 2-13 (Second 58 min.), Miles to Go and Needle Deflection;
SBY-BED (Z1), 2/22/75, Vary Alt, 1225-1608 EST, 1725-2108 GMT.



S/N Station A (dB)



S/N Station B (dB)

Figure B-67. Flight 2-13 (Second 58 min.), S/N Station A and B; SBY-BED (Z1), 2/22/75, Vary Alt, 1225-1608 EST, 1725-2108 GMT.

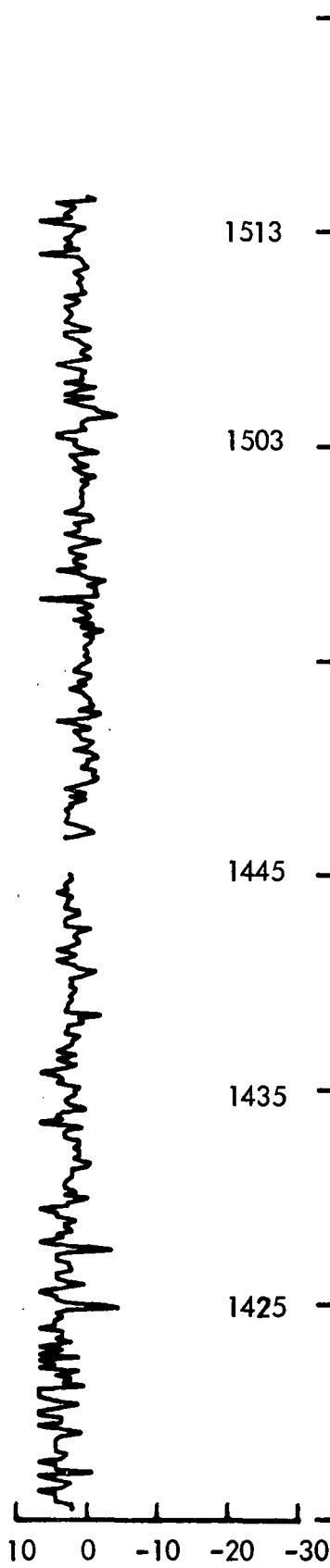

S/N Station C (dB)

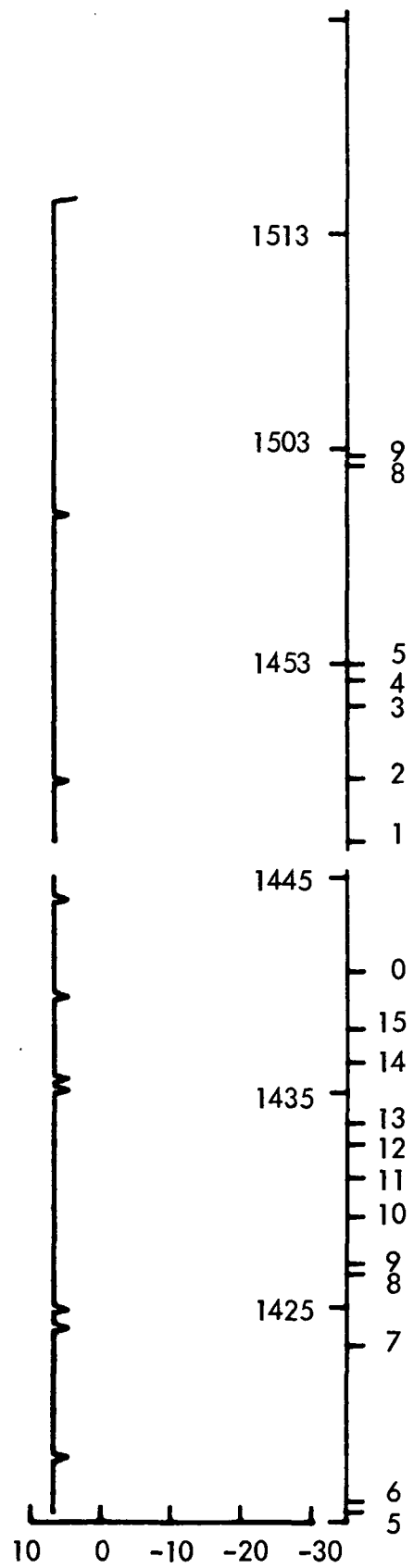

S/N Station D (dB)

Figure B-68 . Flight 2-13 (Second 58 min.), S/N Station C and D; SBY-BED (Z1), 2/22/75, Vary Alt, 1225-1608 EST, 1725-2108 GMT.

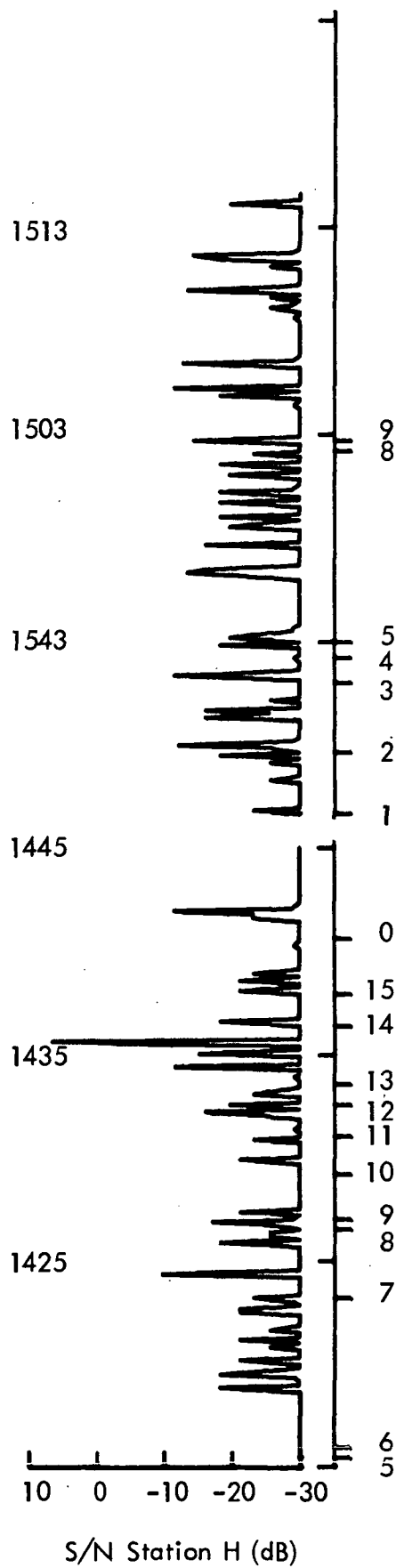

Figure B-69 . Flight 2-13 (Second 58 min.), S/N Station H;
 SBY-BED (Z1), 2/22/75, Vary Alt, 1225-1608 EST, 1725-2108 GMT.

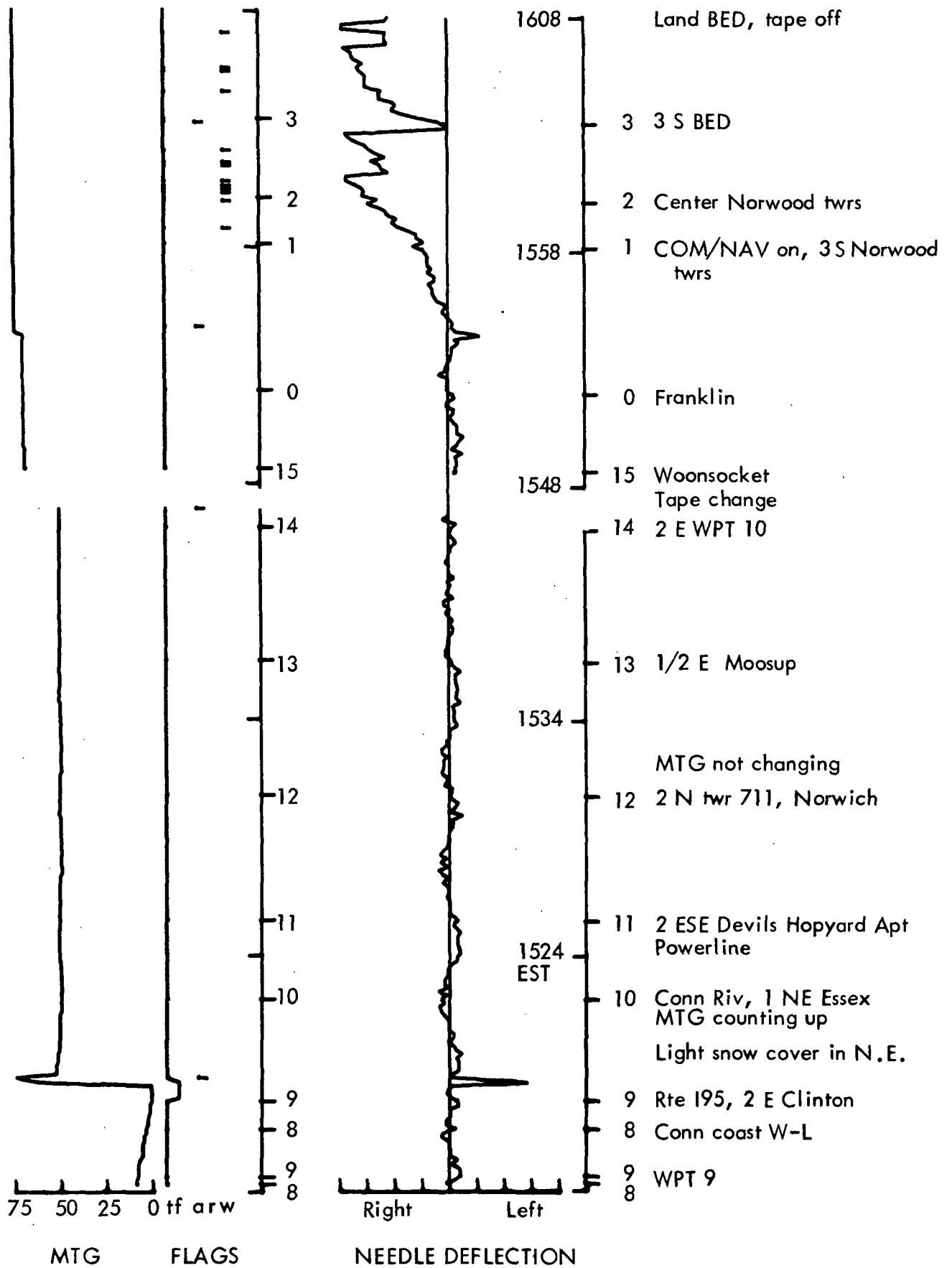

Figure B-70 . Flight 2-13 (Third 54 min.), Miles to Go and Needle Deflection;
 SBY-BED (Z1), 2/22/75, 2000', 1225-1608 EST, 1725-2108 GMT.

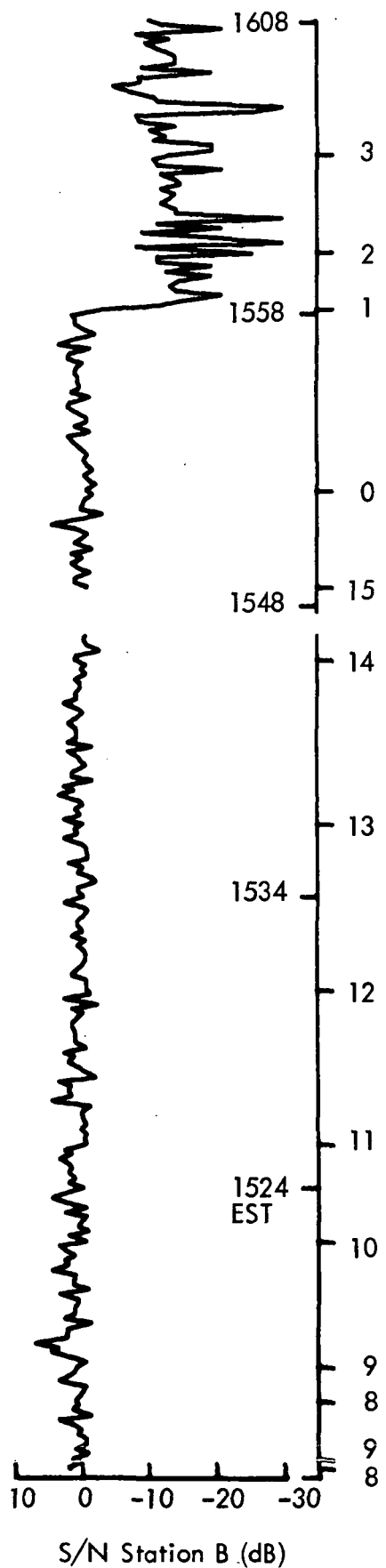
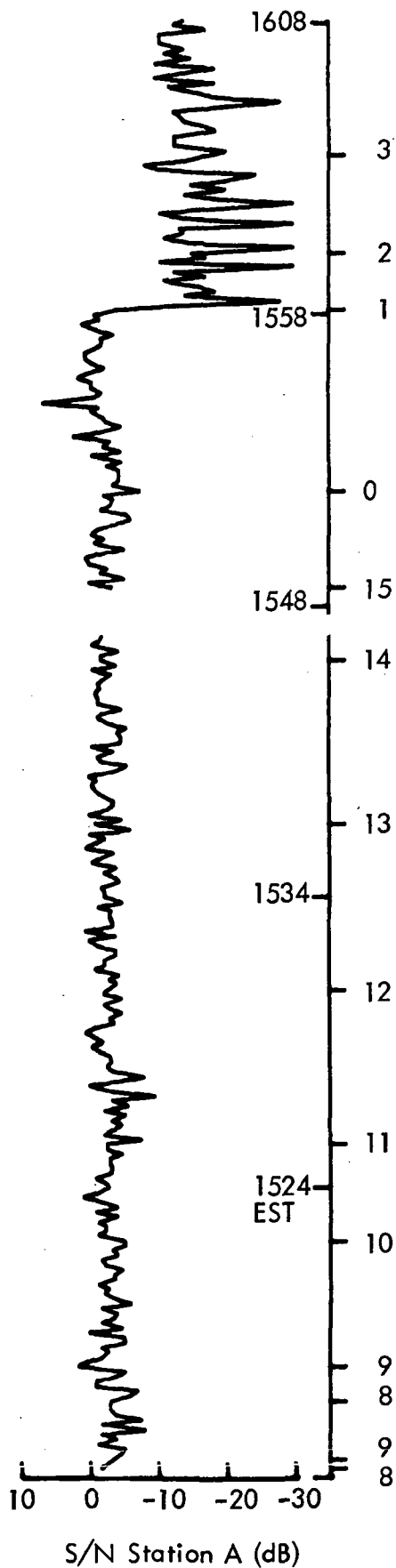
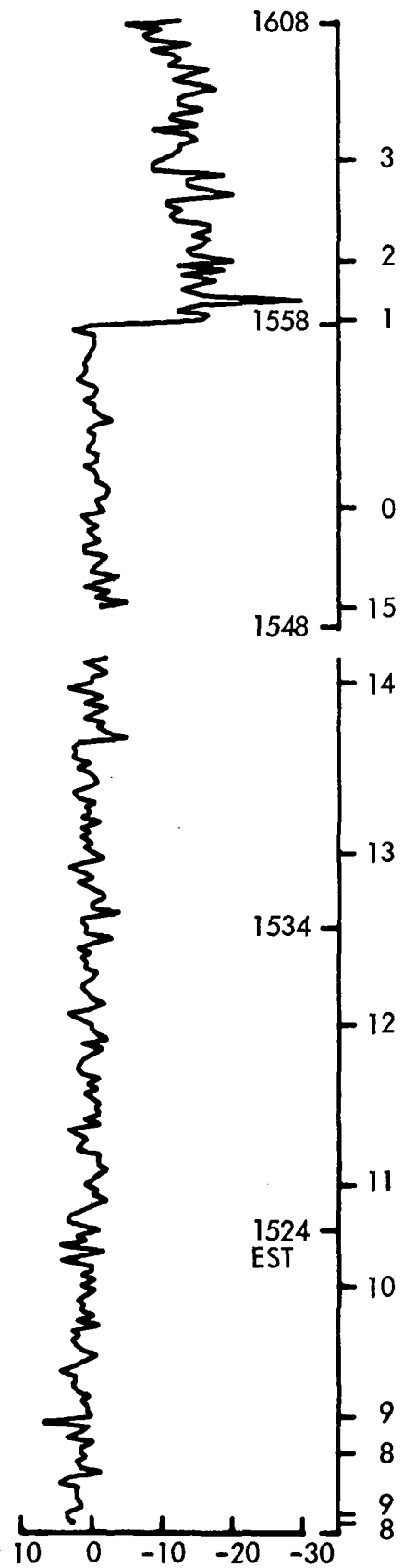
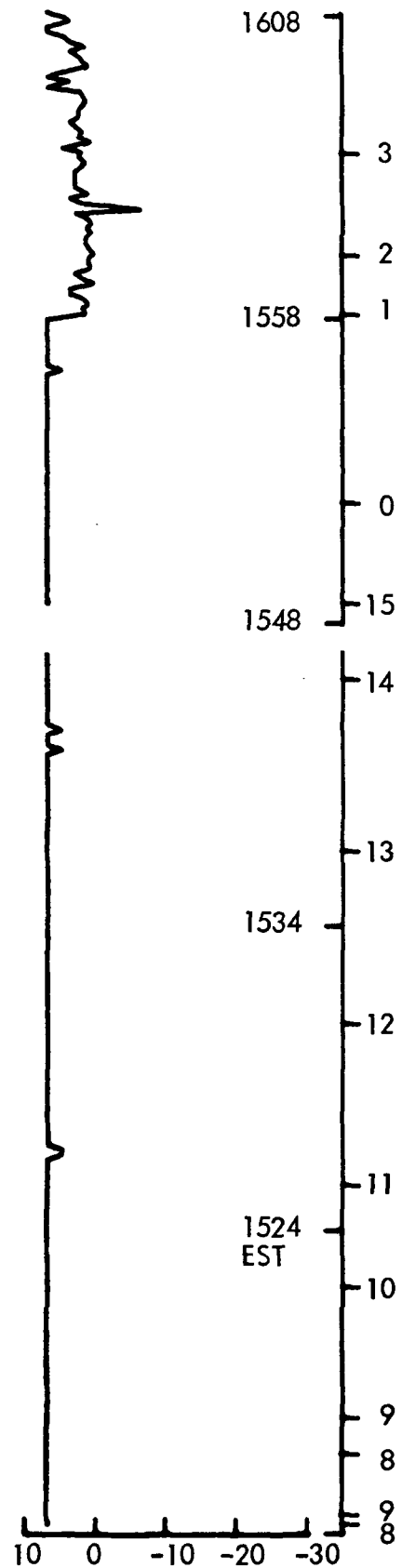

Figure B-71 . Flight 2-13 (Third 54 min.), S/N Station A and B; SBY-BED (Z1), 2/22/75, 2000', 1225-1608 EST, 1725-2108 GMT.



S/N Station C (dB)



S/N Station D (dB)

Figure B-72 . Flight 2-13 (Third 54 min.), S/N Station C and D; SBY-BED (Z1), 2/22/75, 2000', 1225-1608 EST, 1725-2108 GMT.

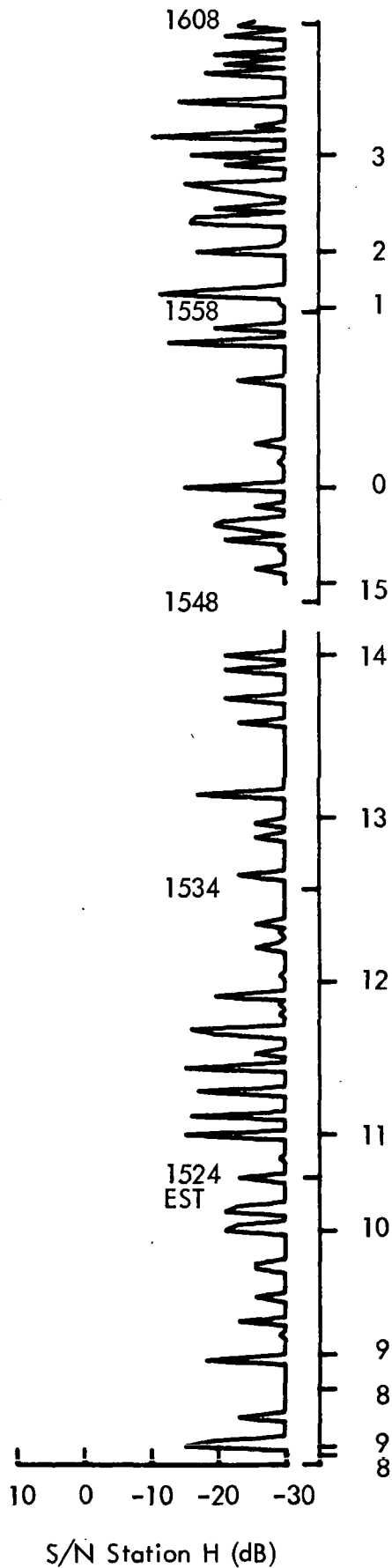

Figure B-73 . Flight 2-13 (Third 54 min.), S/N Station H;
 SBY-BED (Z1), 2/22/75, 2000', 1225-1608 EST, 1725-2108 GMT.

TEST DESCRIPTION

Flight No. 2-21

TEST OBJECTIVES: Obtain data for flight 2-7 which had lost data. Test CIU output with most significant byte chip replaced for LOP 1.

DATE: 2/27/75

DEPARTURE: BED, 1917 EDT

DESTINATION: BED

ROUTE: BED, towers, Framingham, GDM, Haystack, Lowell, BED

ALTITUDE: 2000'

WEATHER: Night VFR

SUMMARY: Flight proceeded as planned. Operation of radios directly affected S/N ratios, transmissions affected data output. Replaced chip worked well on map plot.

KEY WORDS: Suitability, altitude effects, terrain effects, maneuver effects

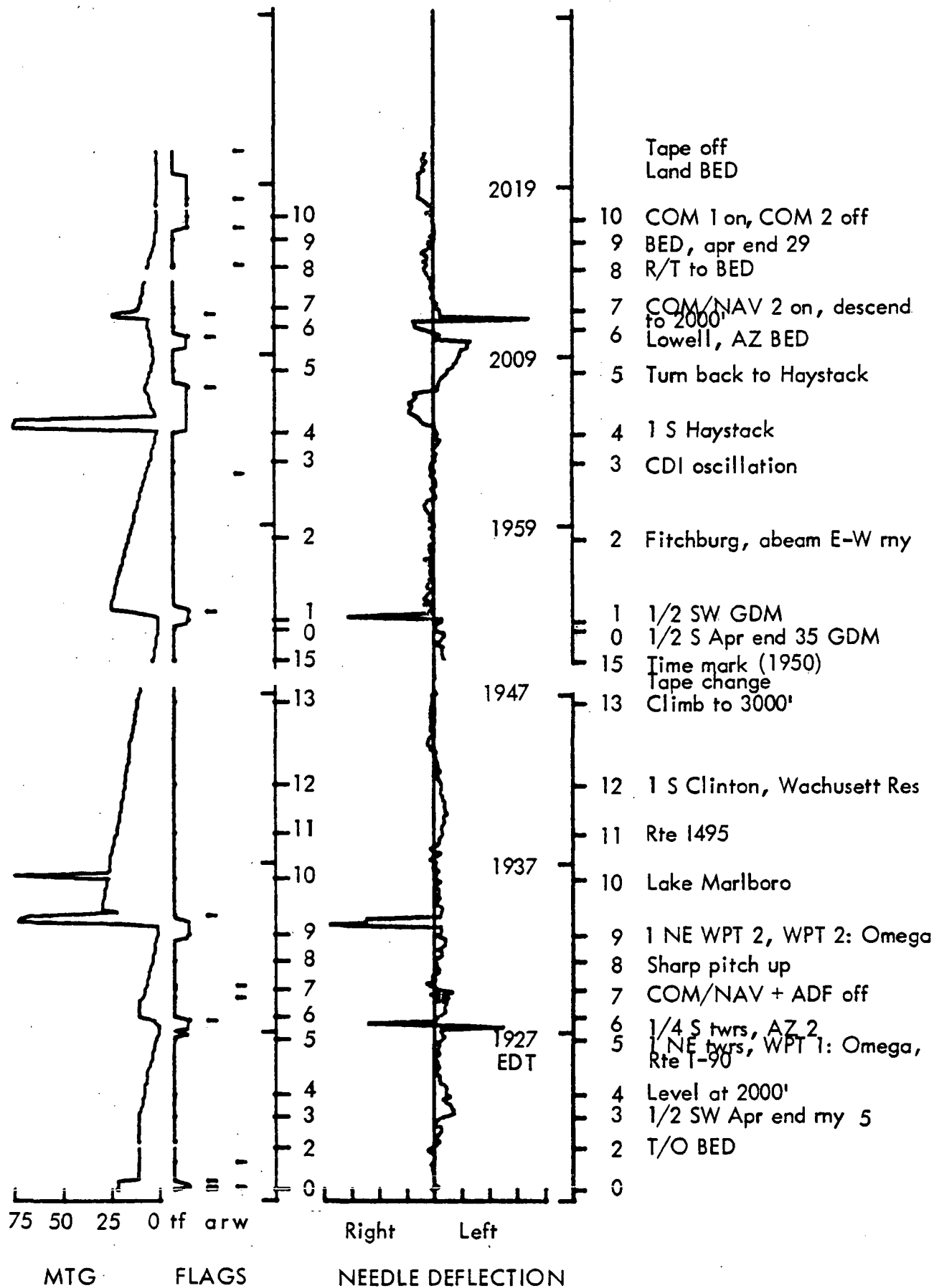

Figure B-74. Flight 2-21, Miles to Go and Needle Deflection;
BED-TWR-FRM-GDM-HST-BED (night), 2/27/75, 2000' AGL, 1917-2021 EDT, 2317-0021 GMT.

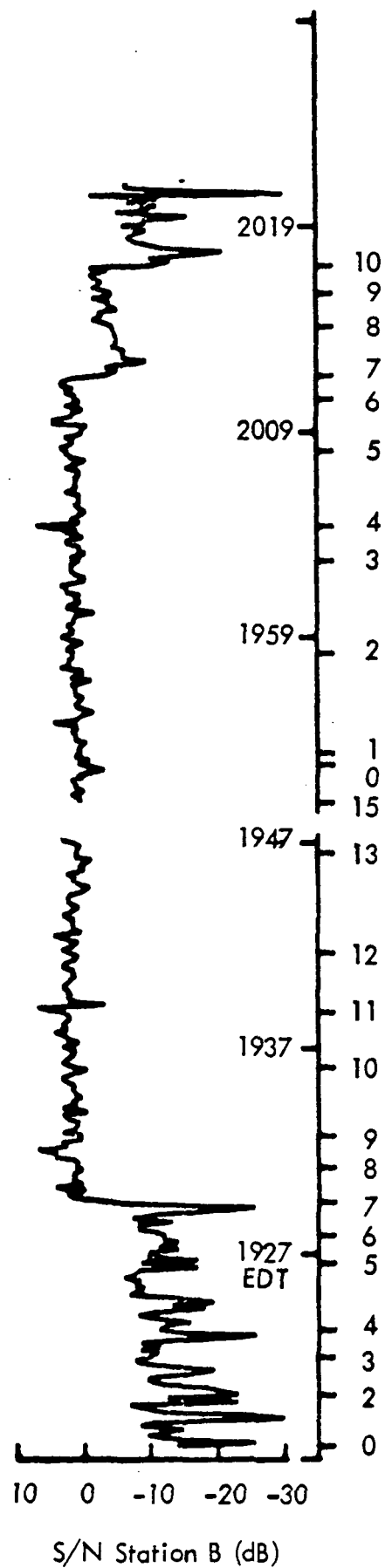
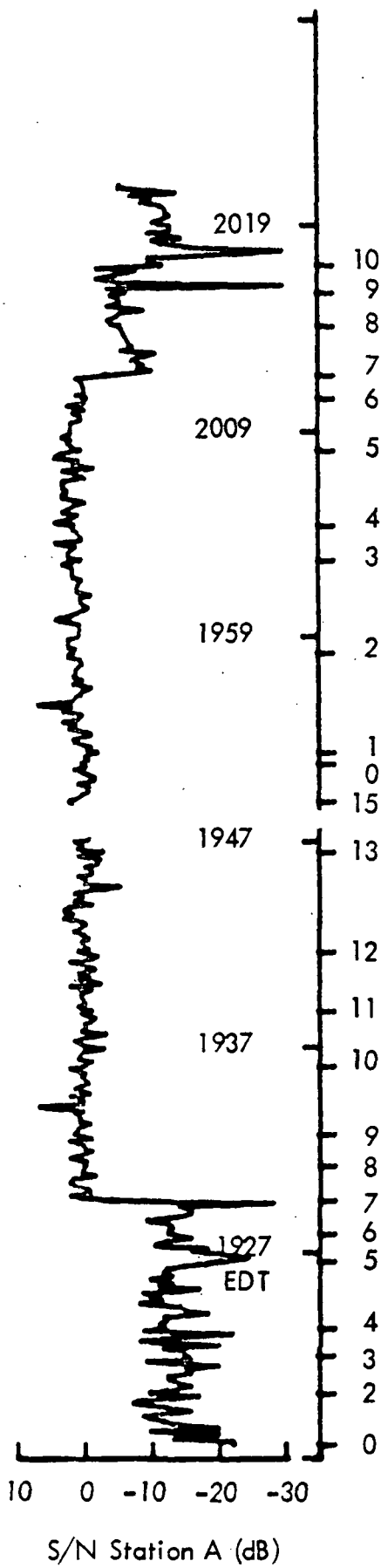

Figure B-75 . Figure 2-21, S/N Station A and B;
 BED-TWR-FRM-GDM-HST-BED (night), 2/27/75, 2000' AGL, 1917-2021 EDT, 2317-0021 GMT.

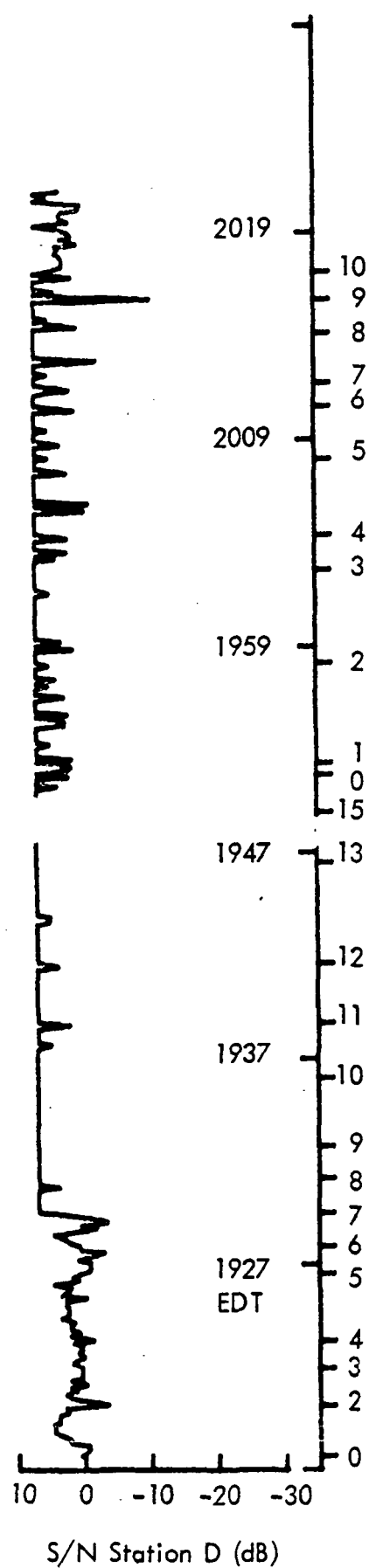
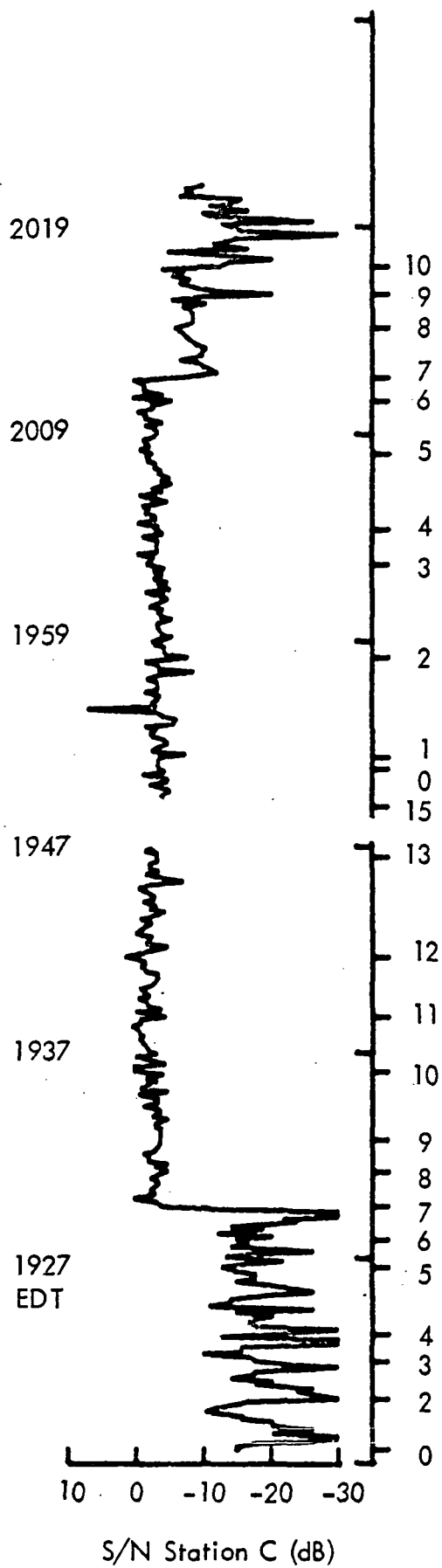

Figure B-76 . Figure 2-21, S/N Station C and D:
 BED-TWR-FROM-GDM-HST-BED (night), 2/27/75, 2000' AGL, 1917-2021 EDT, 2317-0021 GMT.

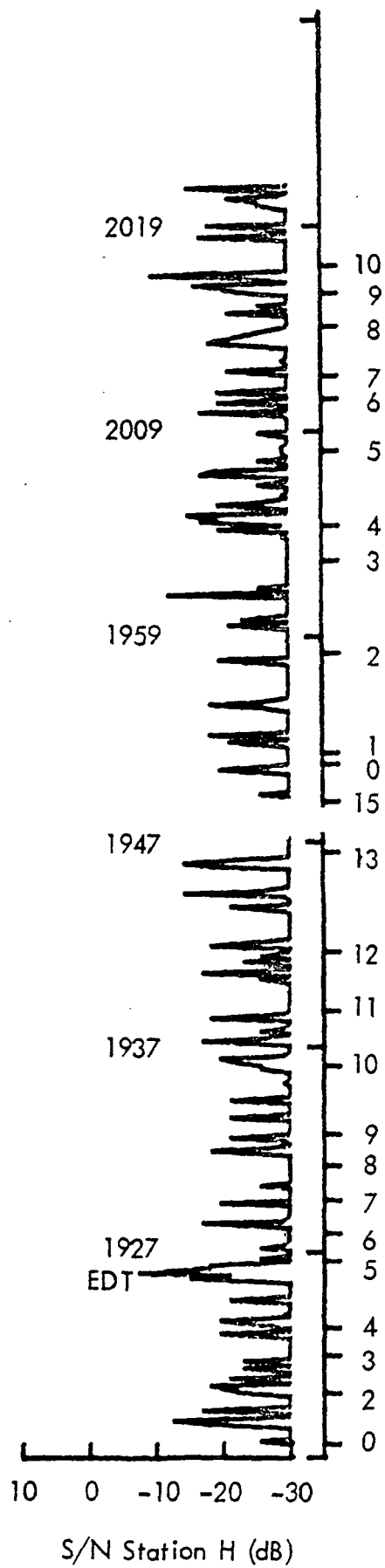

Figure B-77 . Figure 2-21, S/N Station H.
 BED-TWR-FRM-GDM-HST-BED (night), 2/27/75, 2000' AGL, 1917-2021 EDT, 2317-0021 GMT.

TEST DESCRIPTION

Flight No. 2-31

TEST OBJECTIVES: Check CIU operation with additional chip replacement.

DATE: 3/5/75 DEPARTURE: Haverhill
DESTINATION: BED ROUTE: Along AB LOP to BD LOP thru
BED
ALTITUDE: 1200' WEATHER: VFR, 5 kts SW

SUMMARY: Some difficulty was encountered with input of proper initial waypoint along constant AB LOP. Reasonable navigation followed, with final waypoint indication near the airport reference point at BED.*

KEY WORDS: Suitability, altitude effects

*Recorded data was garbled and unusable.

TEST DESCRIPTION

Flight No. 2-41

TEST OBJECTIVES: Provide Zulu route data and preliminary S/N in the Wallops area for the second set of Wallops flights.

DATE: 3/7/75

DEPARTURE: BED, 0930 EDT

DESTINATION: SBY

ROUTE: Zulu 2, divert SBY

ALTITUDE: 2000', 500' under
TCA, 3000'

WEATHER: VFR, 3500' broken cover, 15
kts S

SUMMARY: Good navigation along route, final waypoint indication one mile SSW actual waypoint. Recorded data ceased over Lakehurst due to failed connector at recorder.

KEY WORDS: Suitability, altitude effects, terrain effects

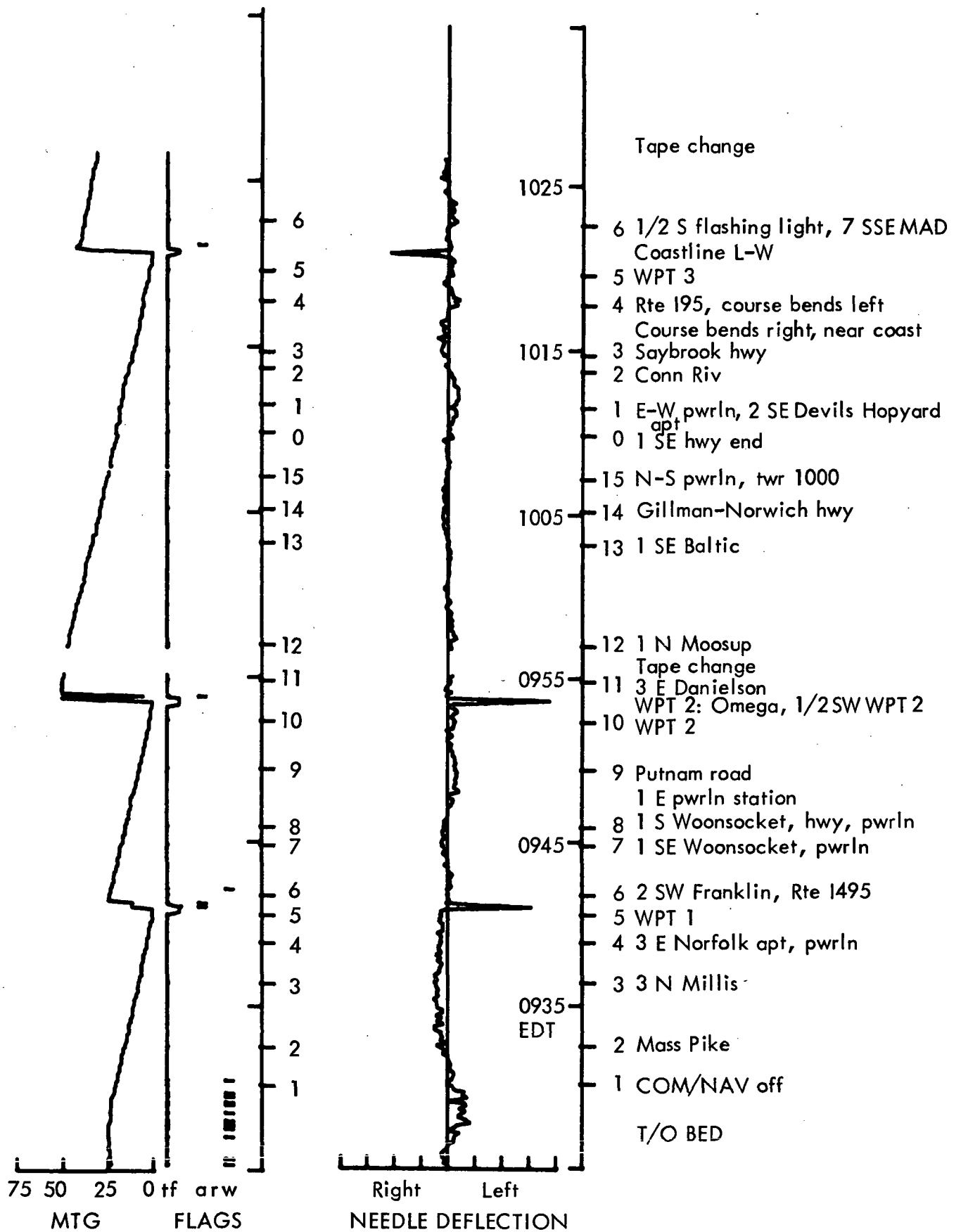

Figure B-78 . Flight 2-41 (First 61 Min), Miles to Go and Needle Deflection;
 BED-SBY (Z1), 3/7/75, 2000', 0926-1302 EDT, 1326-1702 GMT.

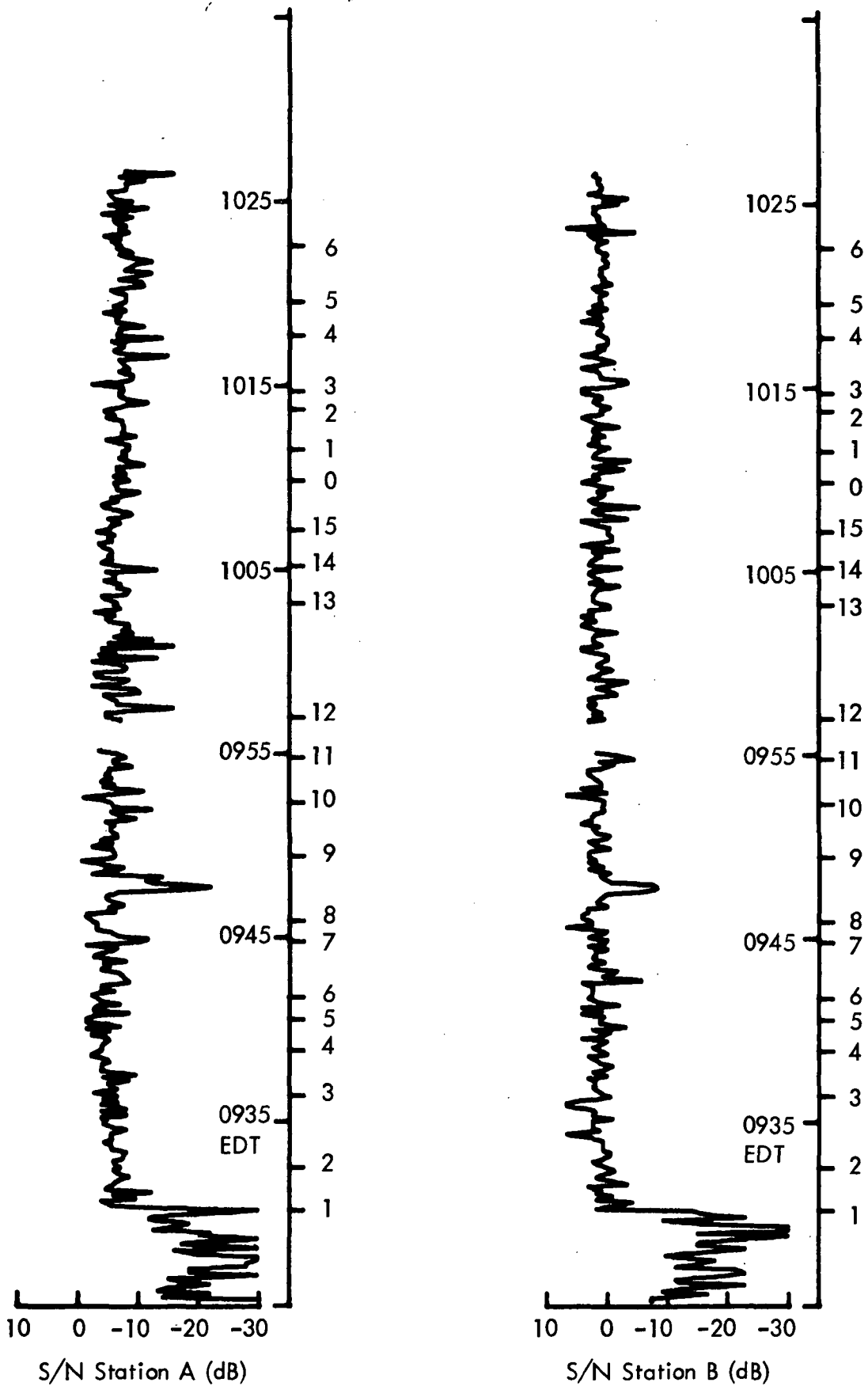

Figure B-79. Flight 2-41 (First 61 Min), S/N Station A and B; BED-SBY (Z1), 3/7/75, 2000', 0926-1302 EDT, 1326-1702 GMT.

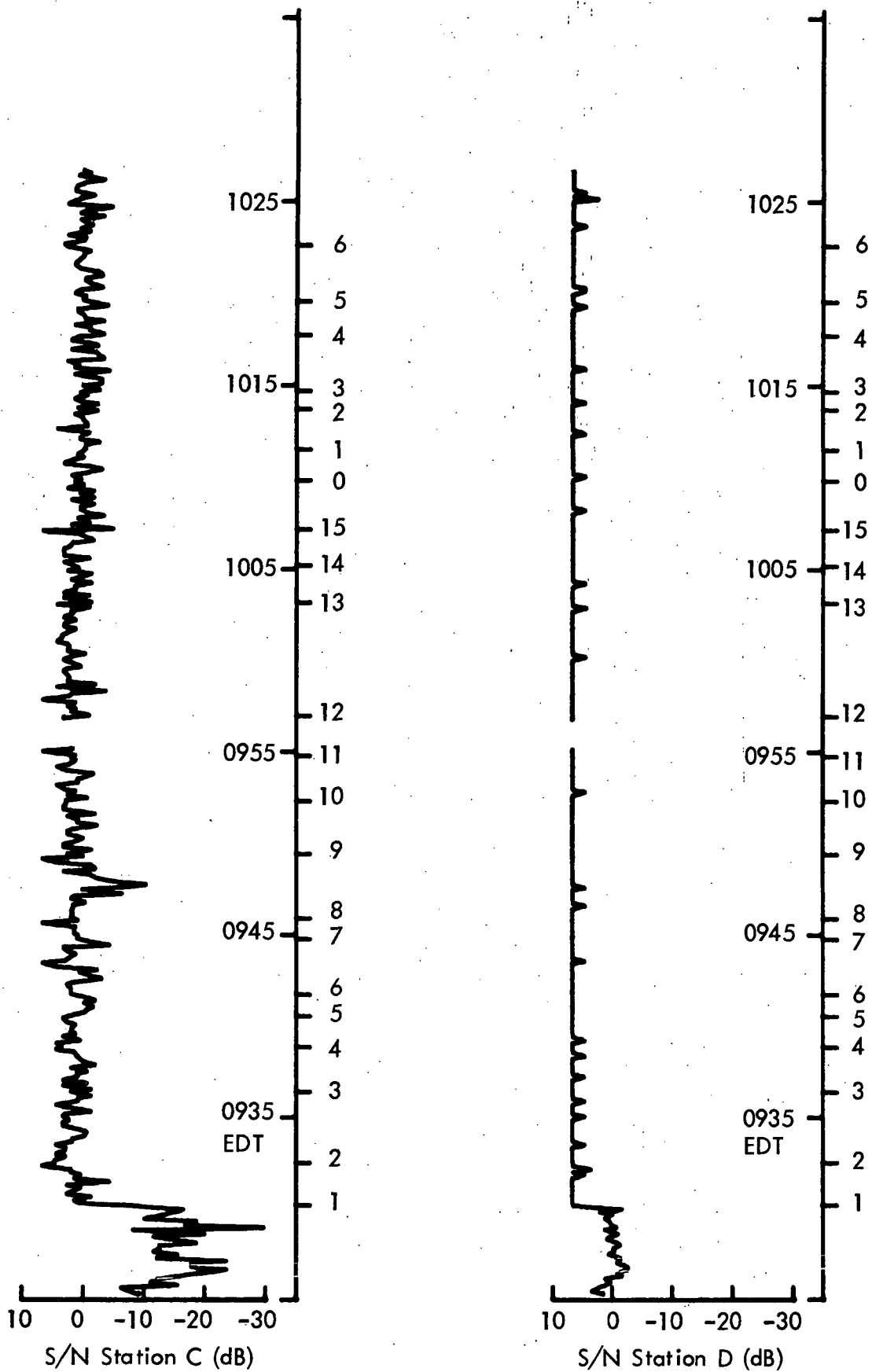

Figure B-80. Flight 2-41 (First 61 Min), S/N Station C and D;
 BED-SBY (Z1), 3/7/75, 2000', 0926-1302 EDT, 1326-1702 GMT.

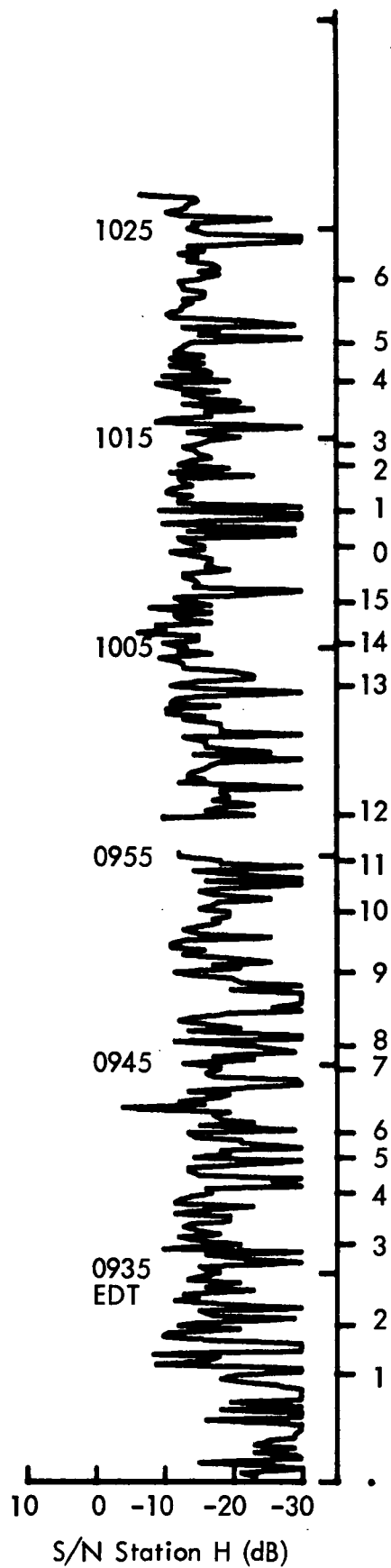

Figure B-81 . Flight 2-41 (First 61 Min), S/N Station H;
 BED-SBY (Z1), 3/7/75, 2000', 0926-1302 EDT, 1326-1702 GMT.

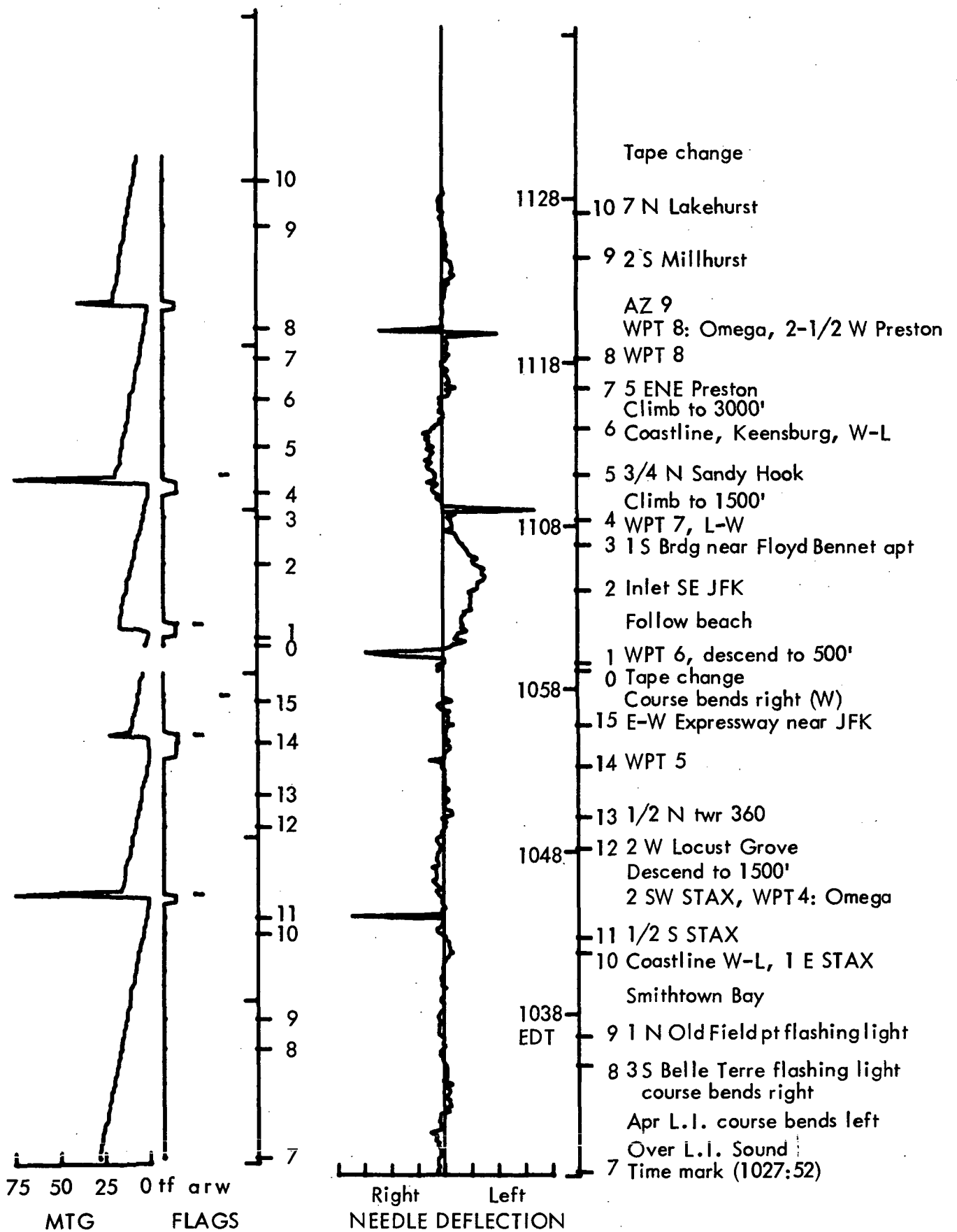

Figure B-82 . Flight 2-41 (Second 60 Min), Miles to Go and Needle Deflection;
 BED-SBY (Z1), 3/7/75, 2000', 0926-1302 EDT, 1326-1702 GMT.

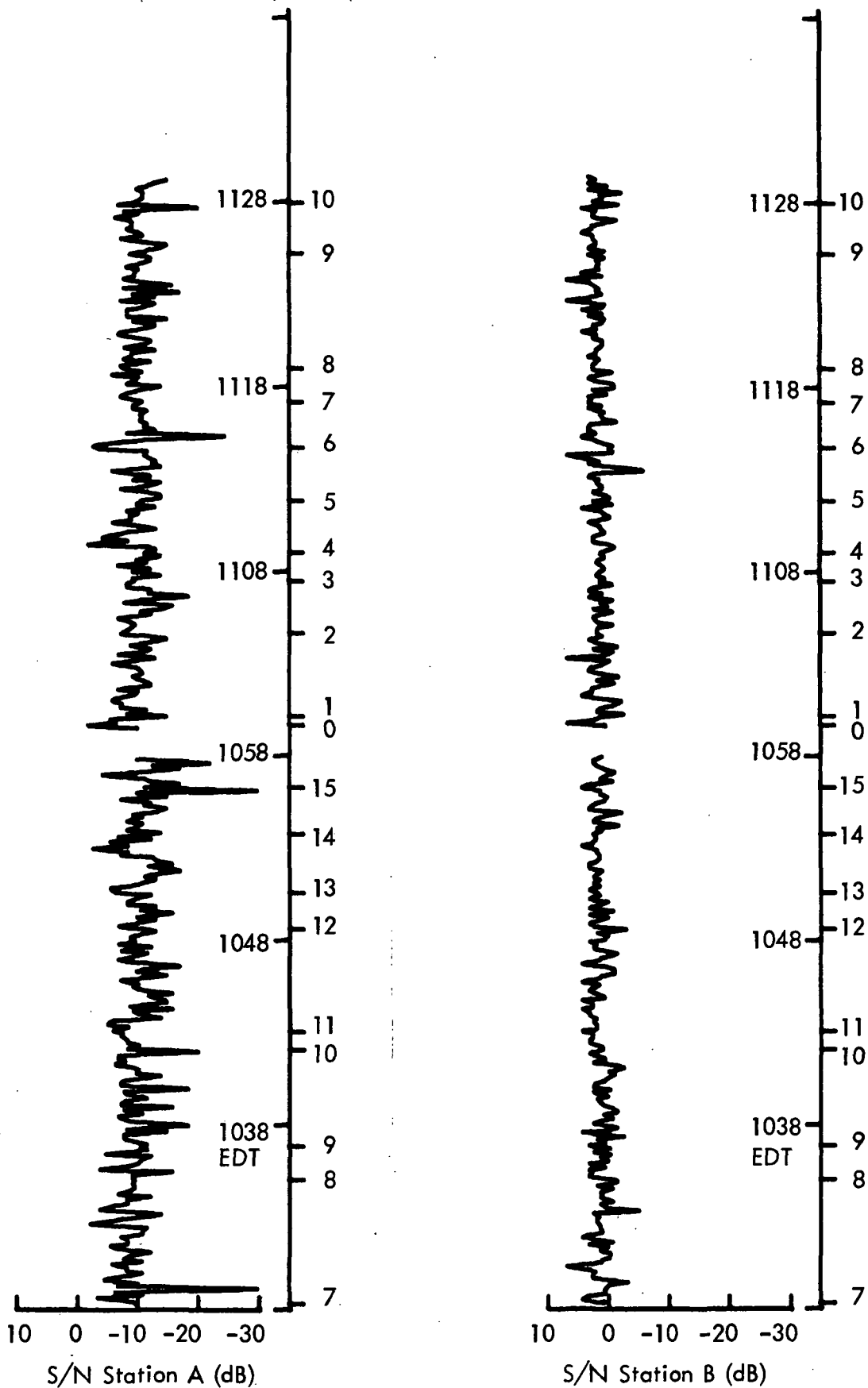

Figure B-83 . Flight 2-41 (Second 60 Min), S/N Station A and B;
 BED-SBY (Z1), 3/7/75, 2000', 0926-1302 EDT, 1326-1702 GMT.

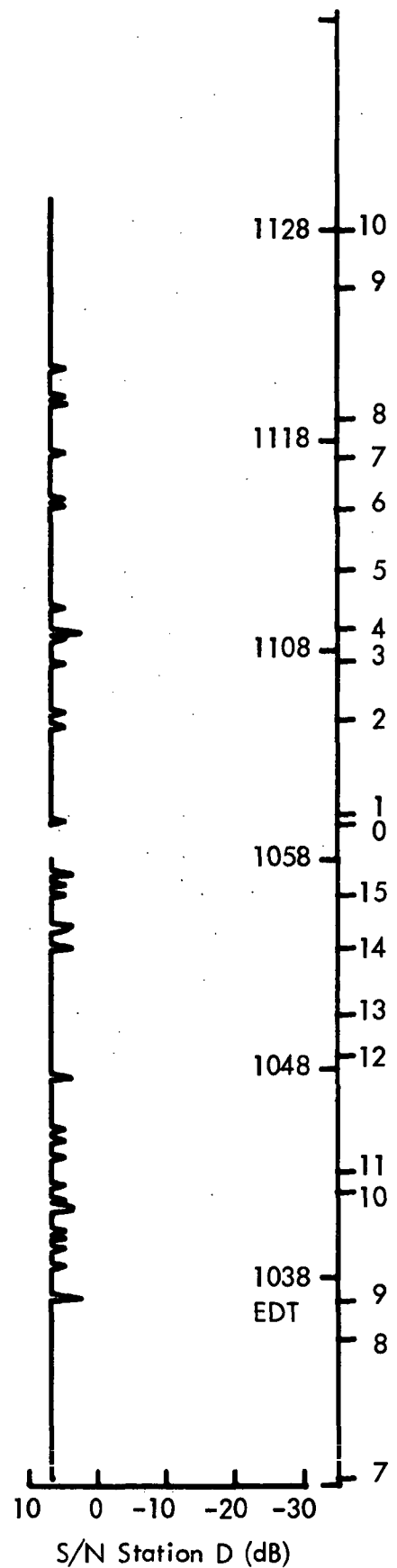
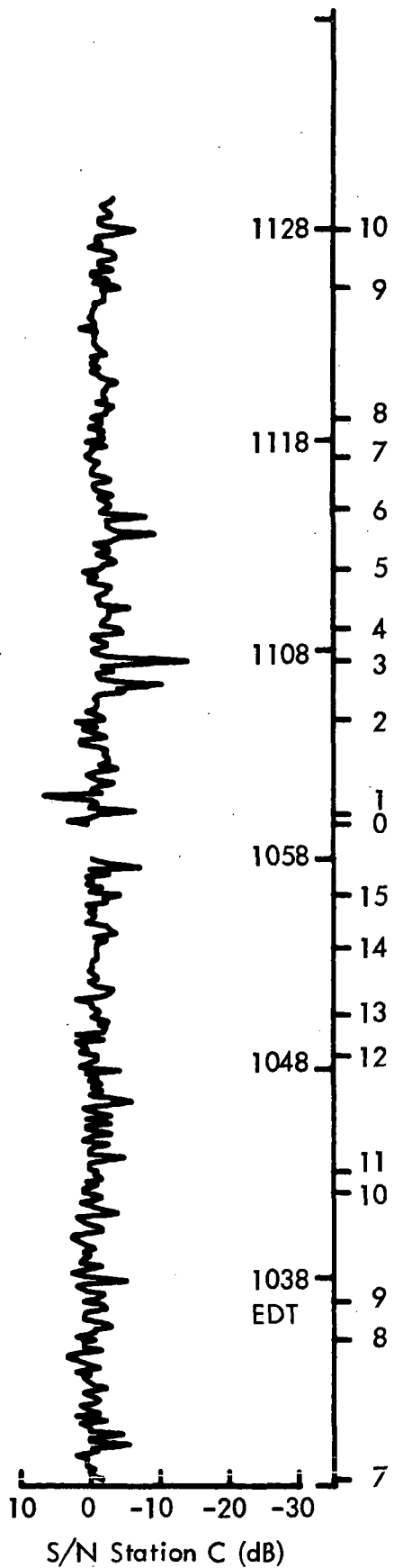

Figure B-84 . Flight 2-41 (Second 60 Min), S/N Station C and D;
 BED-SBY (Z1), 3/7/75, 2000', 0926-1302 EDT, 1326-1702 GMT.

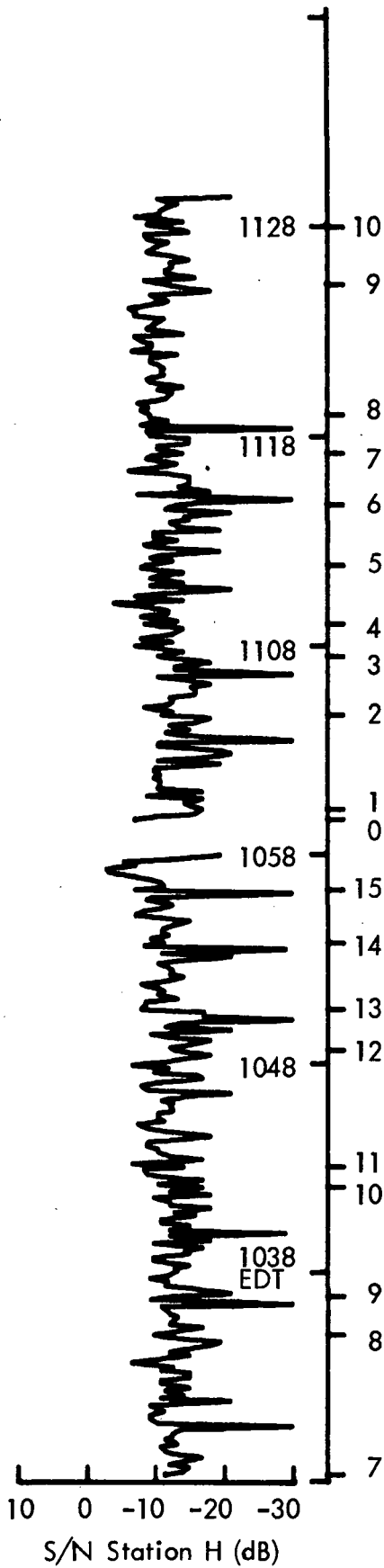

Figure B-85 . Flight 2-41 (Second 60 Min), S/N Station H;
 BED-SBY (Z1), 3/7/75, 2000', 0926-1302 EDT, 1326-1702 GMT.

TEST DESCRIPTION

Flight No. 2-44

TEST OBJECTIVES: Provide final S/N data in Wallops area. Check Zulu route at high altitude (5500' and 7500')

DATE: 3/9/75 **DEPARTURE:** SBY, 1330 EDT

DESTINATION: BED **ROUTE:** Direct Beach wpt, Zulu 1 to BED

ALTITUDE: 5500', 7500' over **WEATHER:** VFR, 15 kts NNB
NY TCA

SUMMARY: Lost track due to weak S/N for Station A over Southern New Jersey. Tried using BC and BD LOP pair unsuccessfully. Resumed using AB and BD over Stacks wpt, flying constant BD LOP to BED from BDR.

KEY WORDS: Suitability, altitude effects, terrain effects

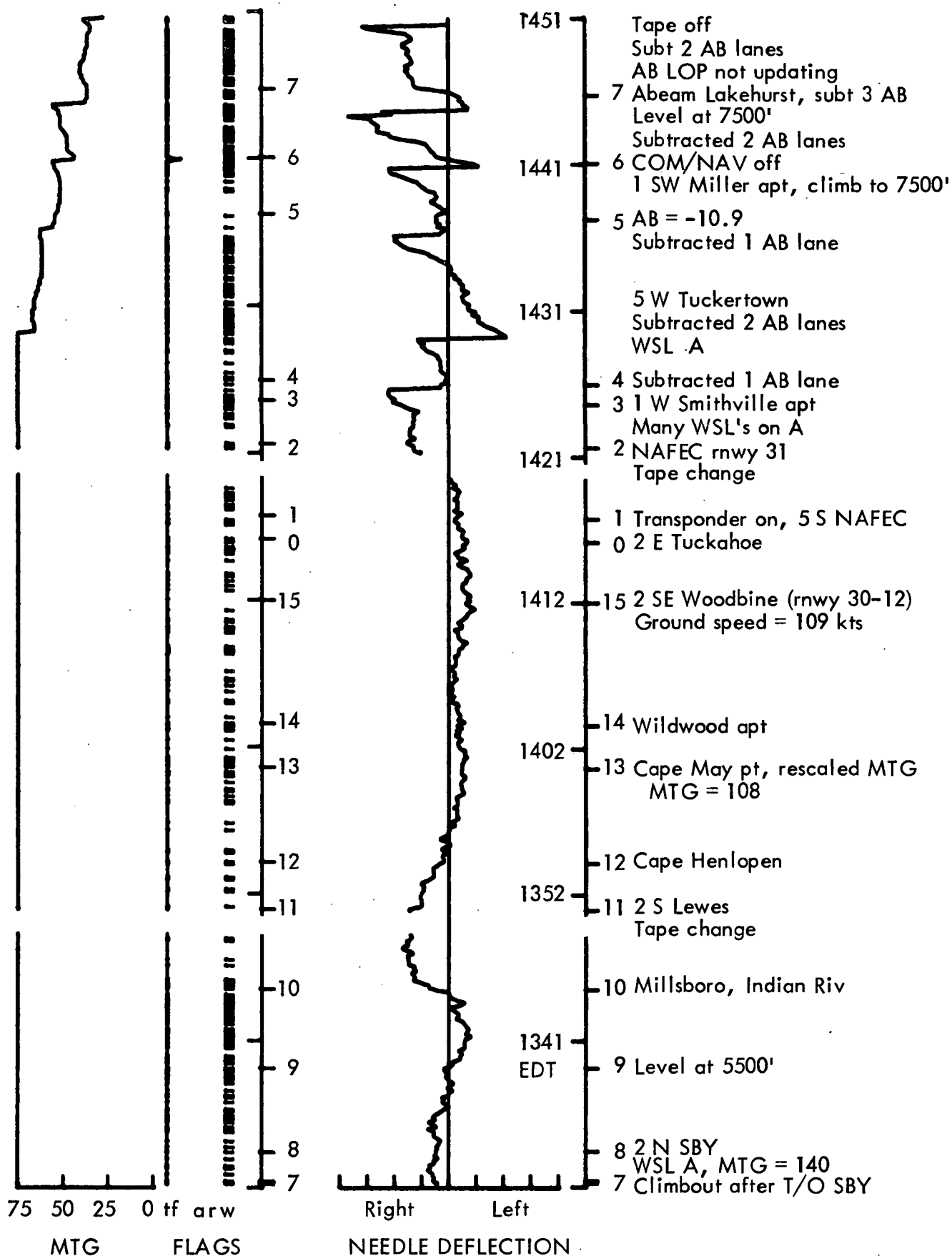

Figure B-86 . Flight 2-44 (First 80 Min), Miles to Go and Needle Deflection;
SBY-BED (Z1), 3/9/75, 5500' (Over TCA), 1330-1646 EDT, 1730-2046 GMT.

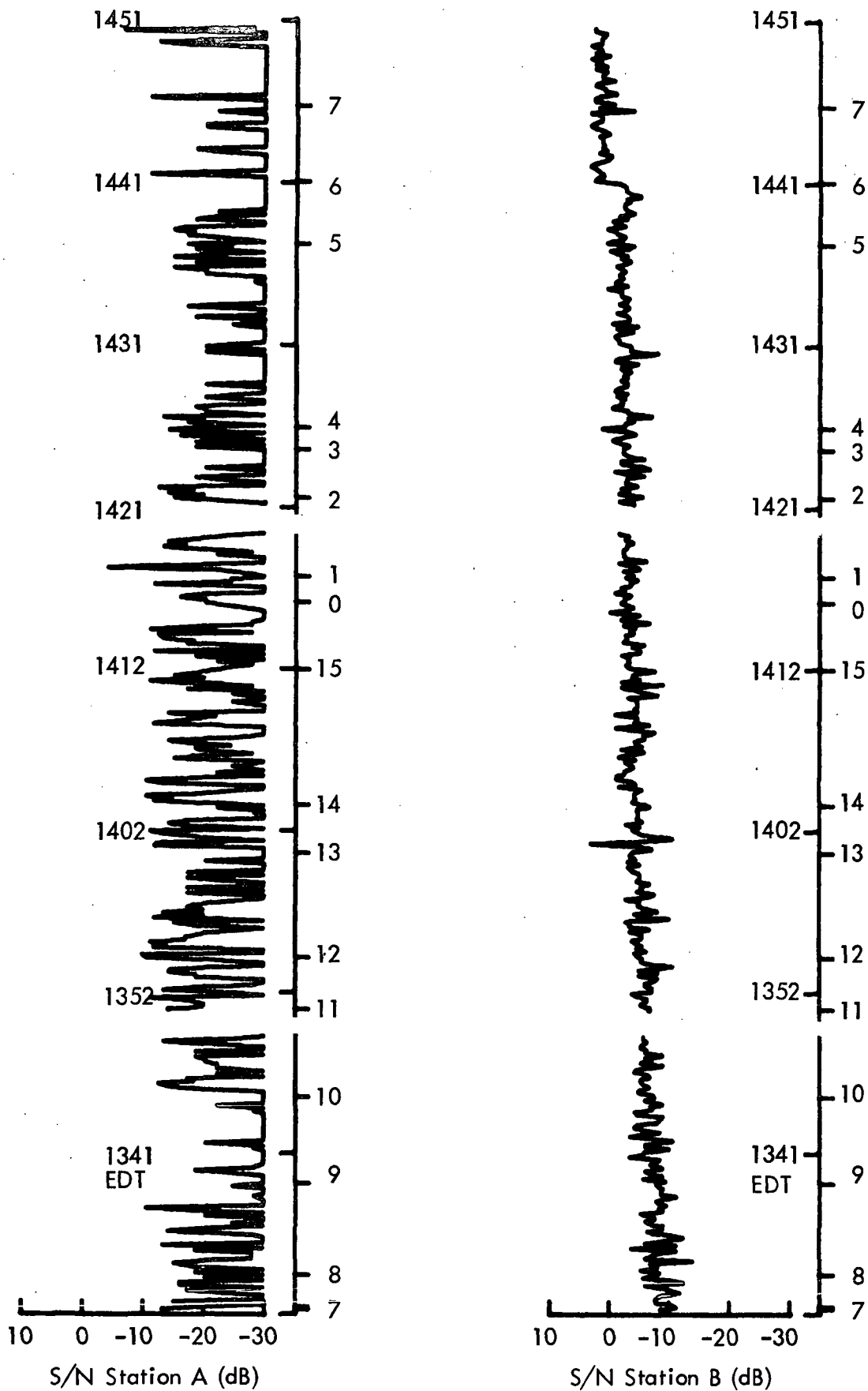

Figure B-87 . Flight 2-44 (First 80 Min), S/N Station A and B;
 SBY-BED (Z1), 3/9/75, 5500' (Over TCA), 1330-1646 EDT, 1730-2046 GMT.

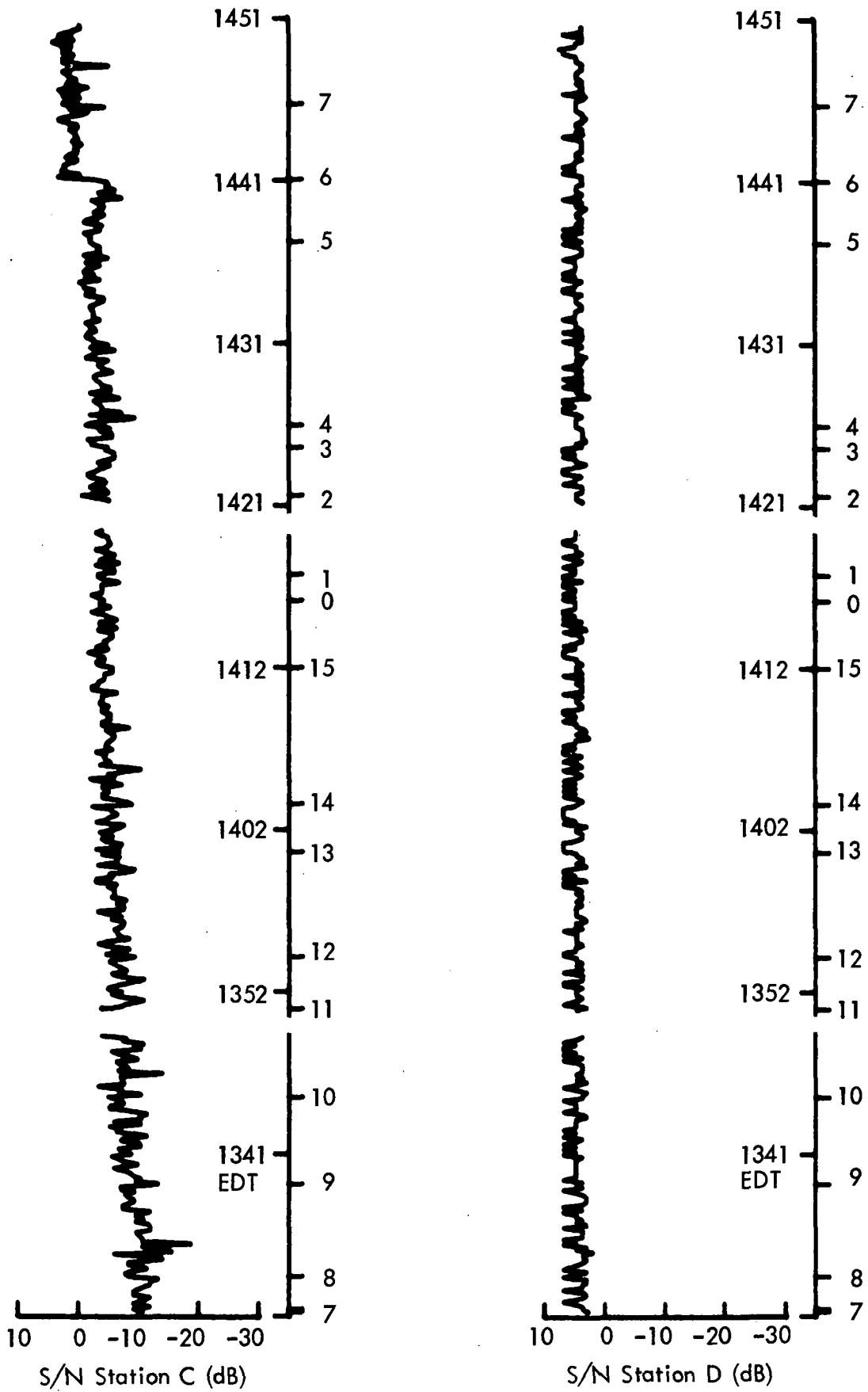

Figure B-88 . Flight 2-44 (First 80 Min), S/N Station C and D;
 SBY-BED (Z1), 3/9/75, 5500' (Over TCA), 1330-1646 EDT, 1730-2046 GMT.

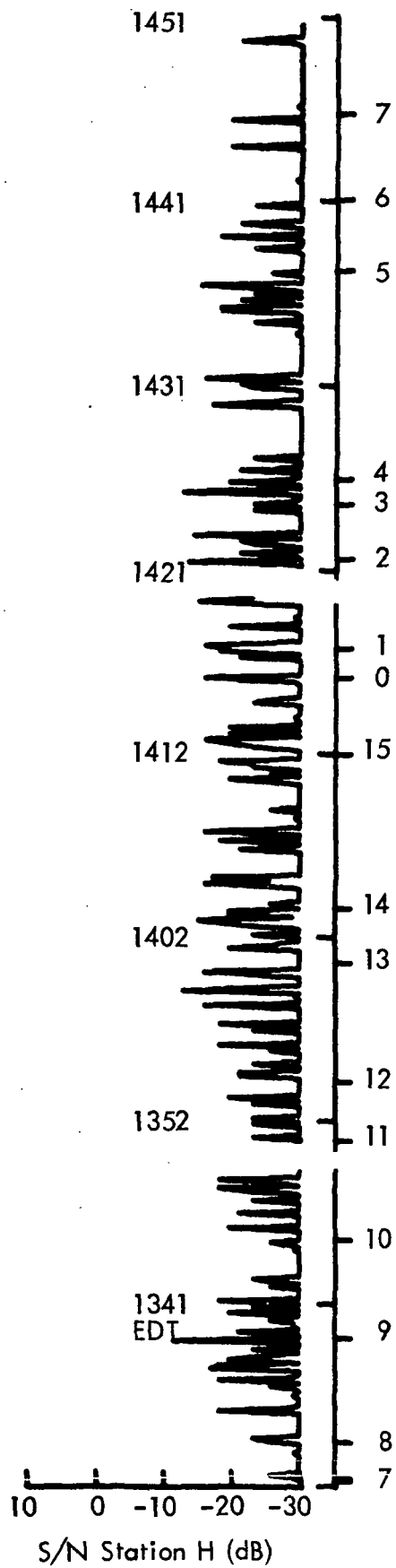

Figure B-89 . Flight 2-44 (First 80 Min), S/N Station H;
 SBY-BED (Z1), 3/9/75, 5500' (Over TCA), 1330-1646 EDT, 1730-2046 GMT.

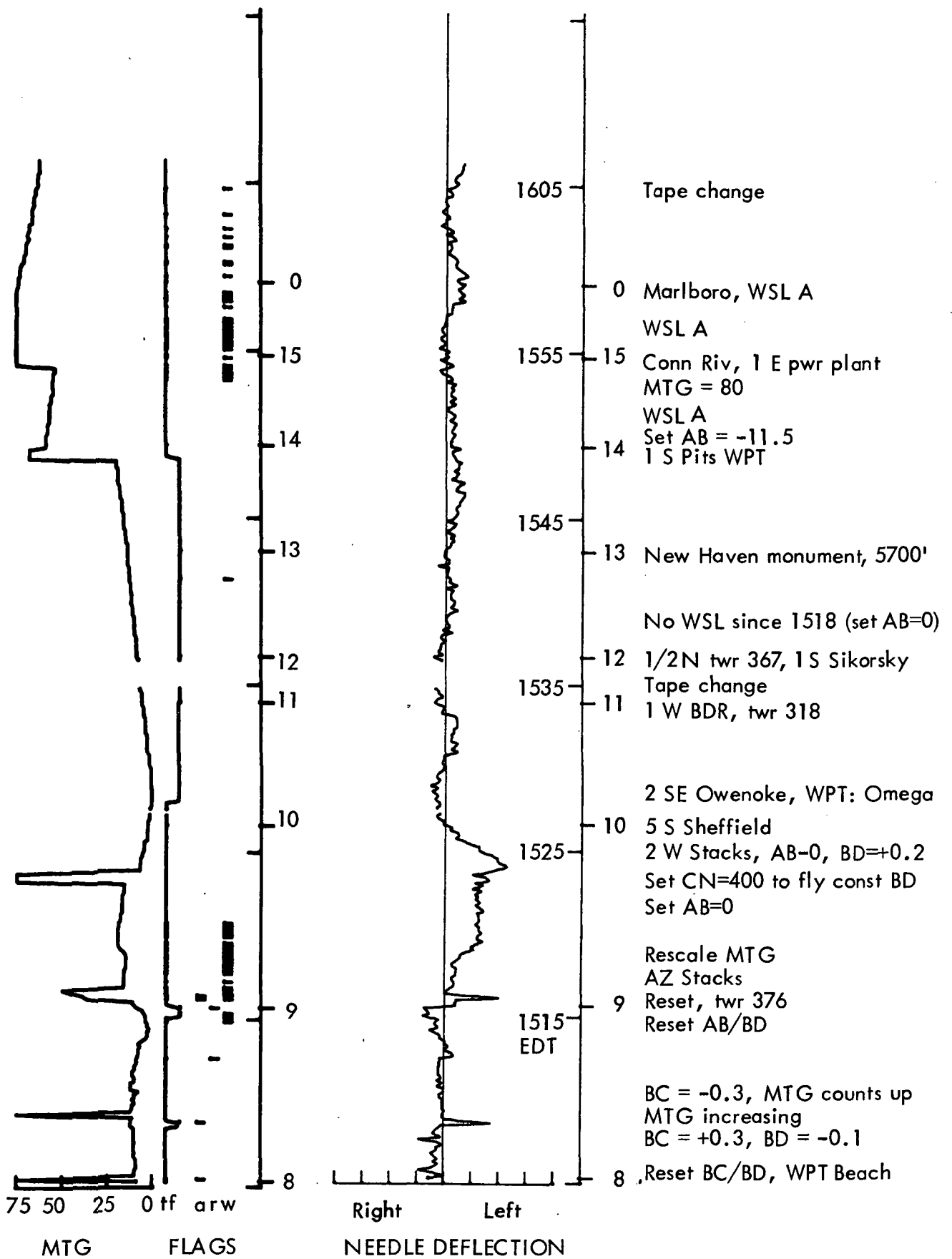

Figure B-90 . Flight 2-44 (Second 62 Min), Miles to Go and Needle Deflection;
SBY-BED (Z1), 3/9/75, 5500' (Over TCA), 1330-1646 EDT, 1730-2046 GMT.

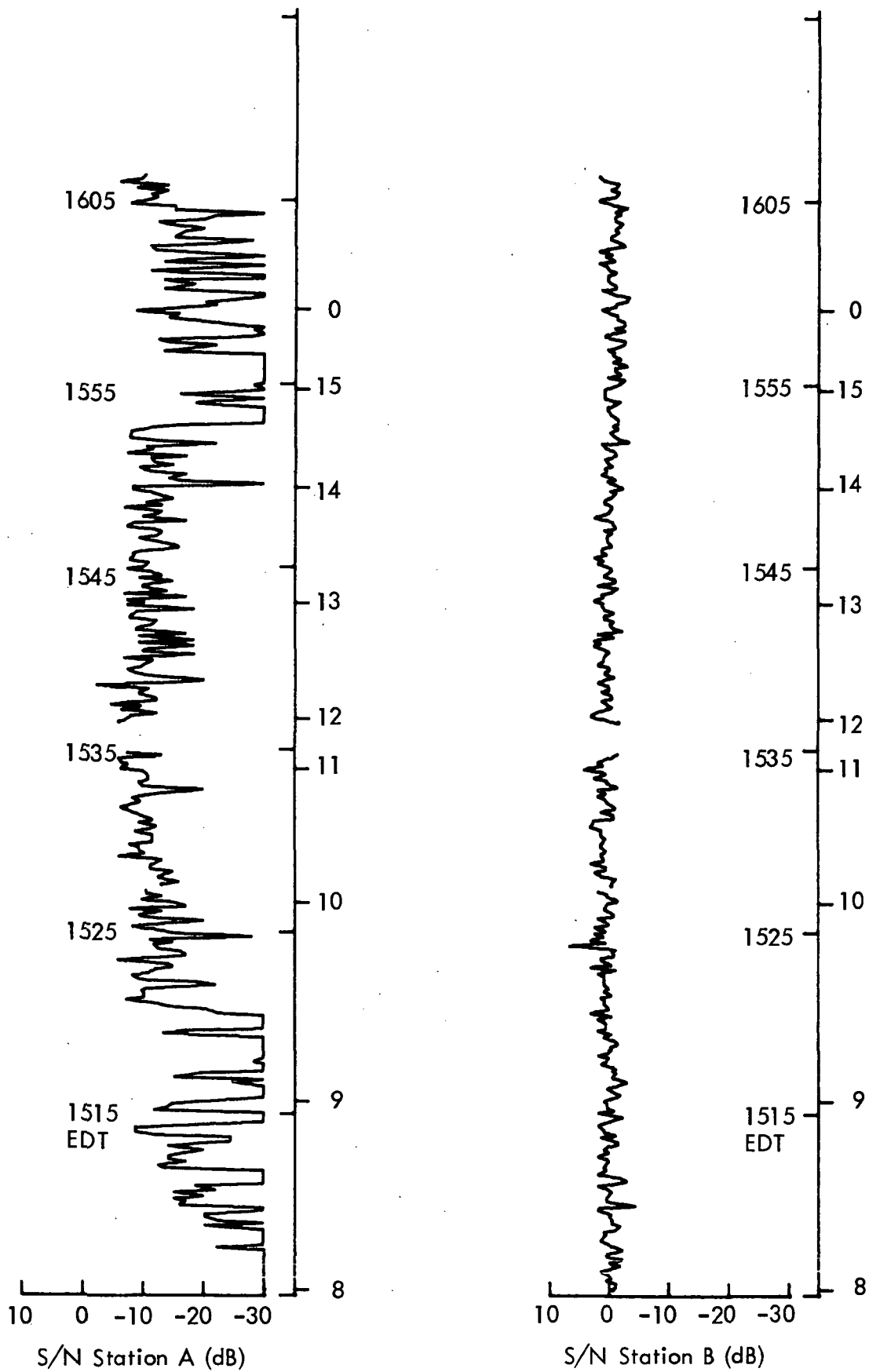

Figure B-91 . Flight 2-44 (Second 62 Min), S/N Station A and B; SBY-BED (Z1), 3/9/75, 5500' (Over TCA), 1330-1646 EDT, 1730-2046 GMT.

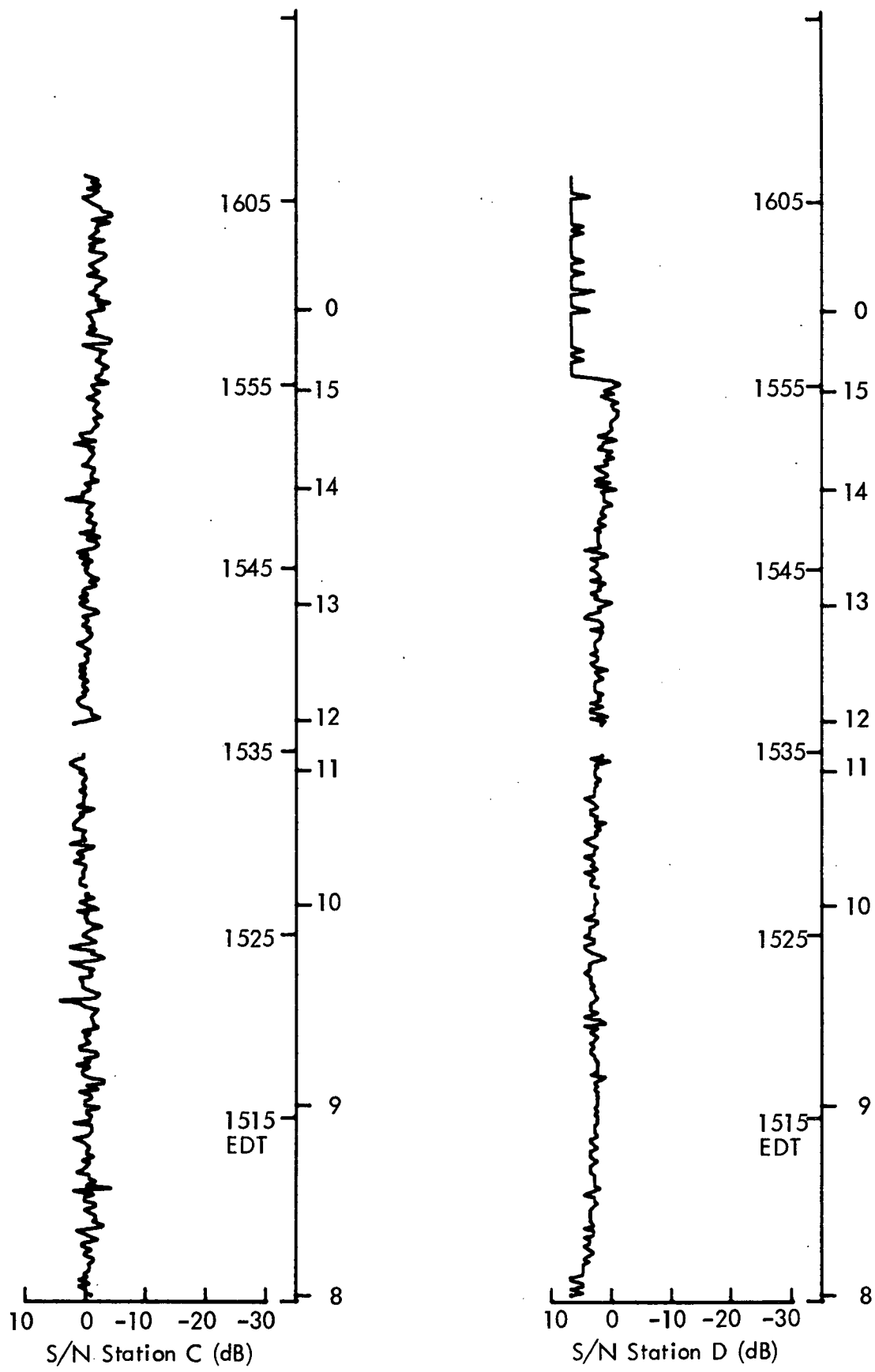

Figure B-92 . Flight 2-44 (Second 62 Min), S/N Station C and D;
 SBY-BED (Z1), 3/9/75, 5500' (Over TCA), 1330-1646 EDT, 1730-2046 GMT.

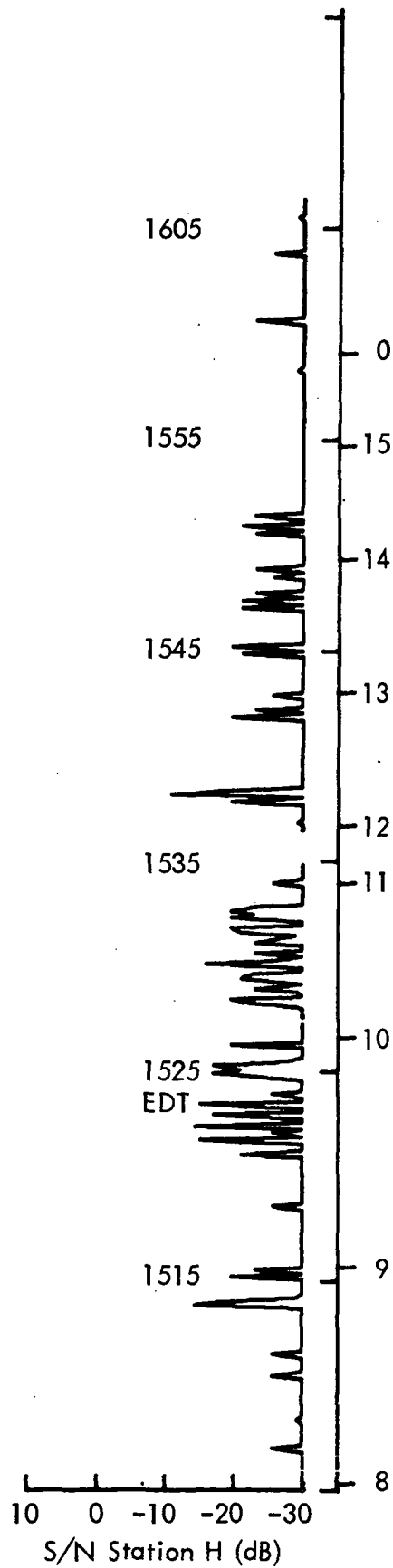

Figure B-93 . Flight 2-44 (Second 62 Min), S/N Station H;
 SBY-BED (Z1), 3/9/75, 5500' (Over TCA), 1330-1646 EDT, 1730-2046 GMT.

B - 115

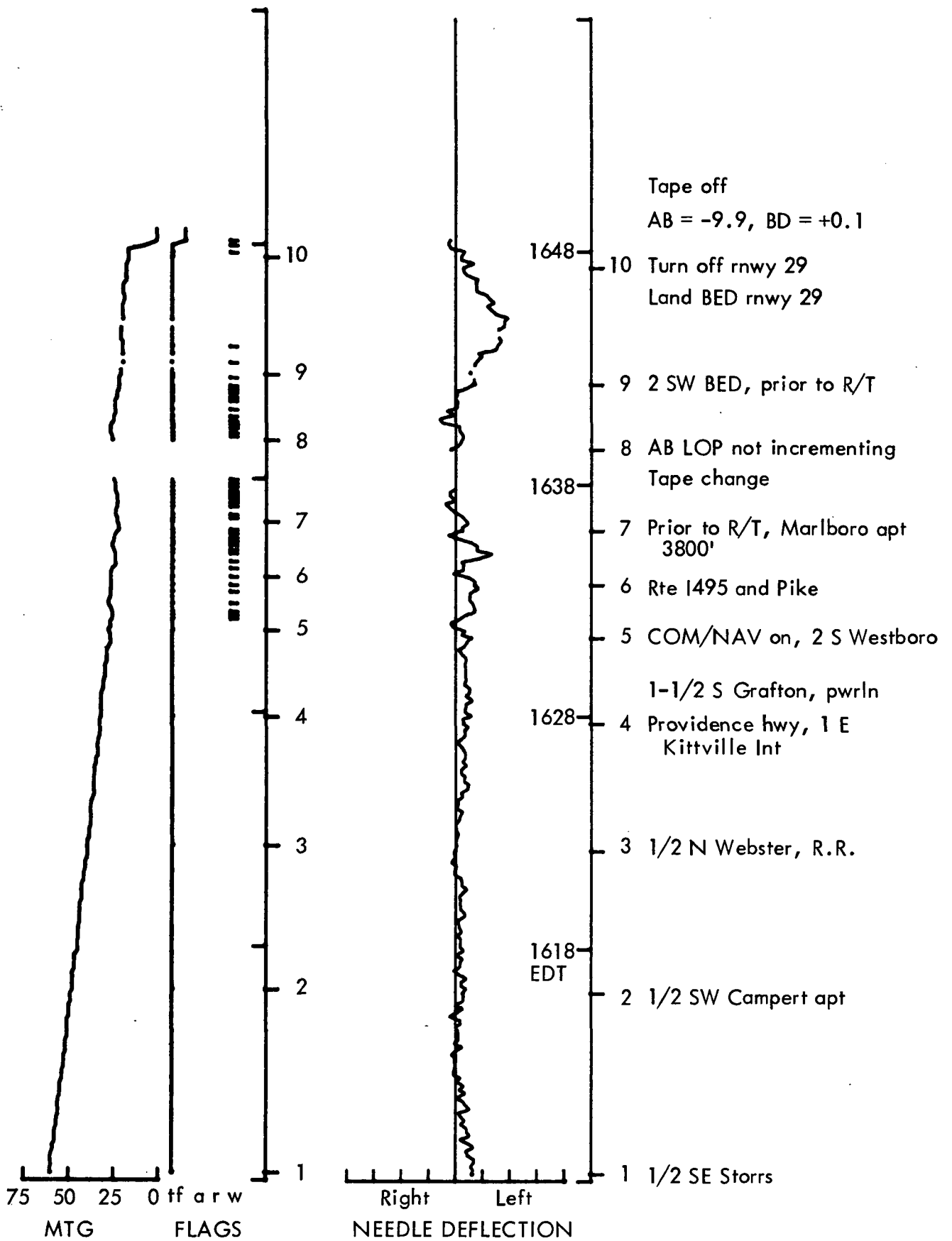

Figure B-94 . Flight 2-44 (Third 41 Min), Miles to Go and Needle Deflection;
SBY-BED (Z1), 3/9/75, 5500' (Over TCA), 1330-1646 EDT, 1730-2046 GMT.

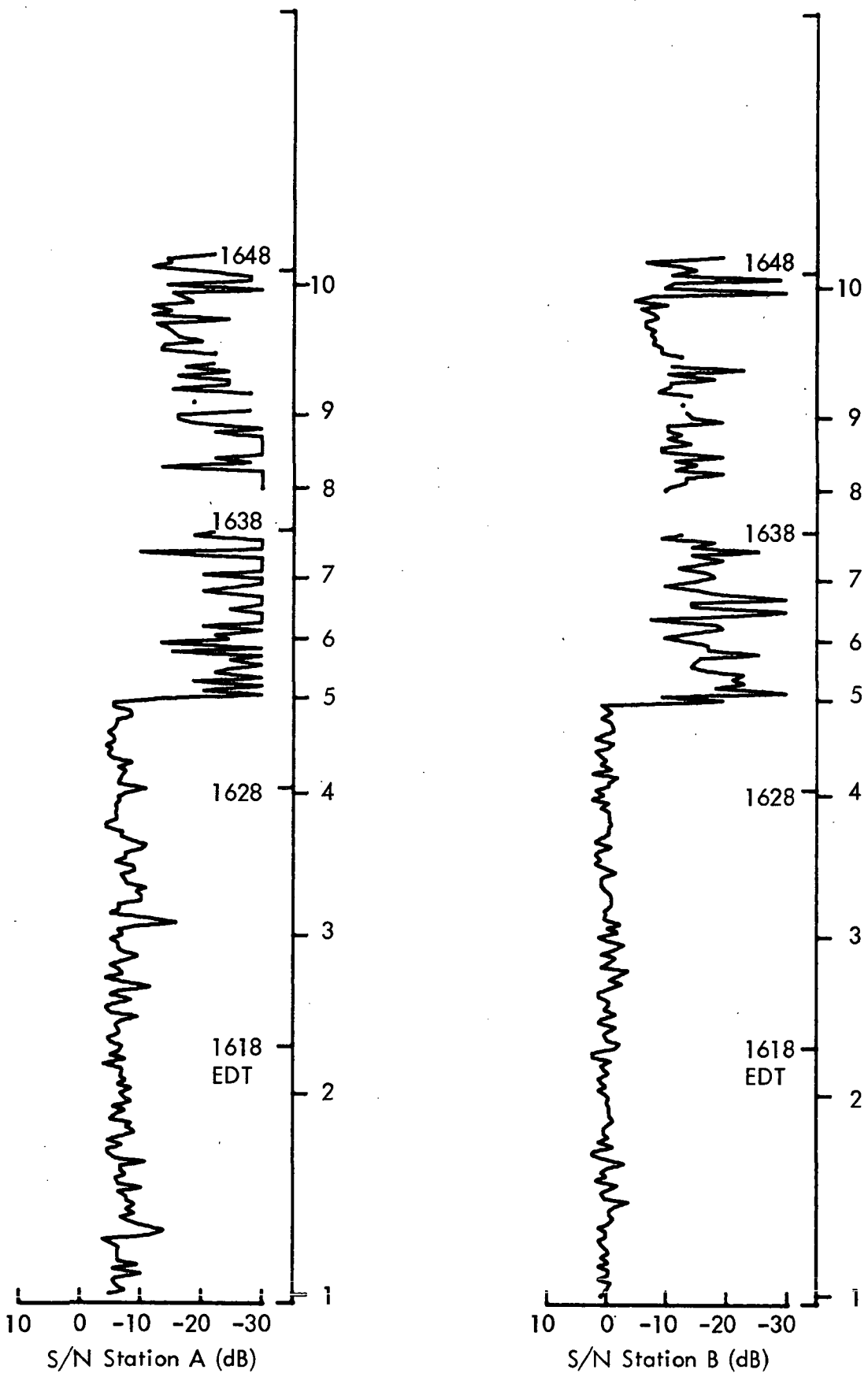

Figure B-95. Flight 2-44 (Third 41 Min), S/N Station A and B; SBY-BED (Z1), 3/9/75, 5500' (Over TCA), 1330-1646 EDT, 1730-2046 GMT.

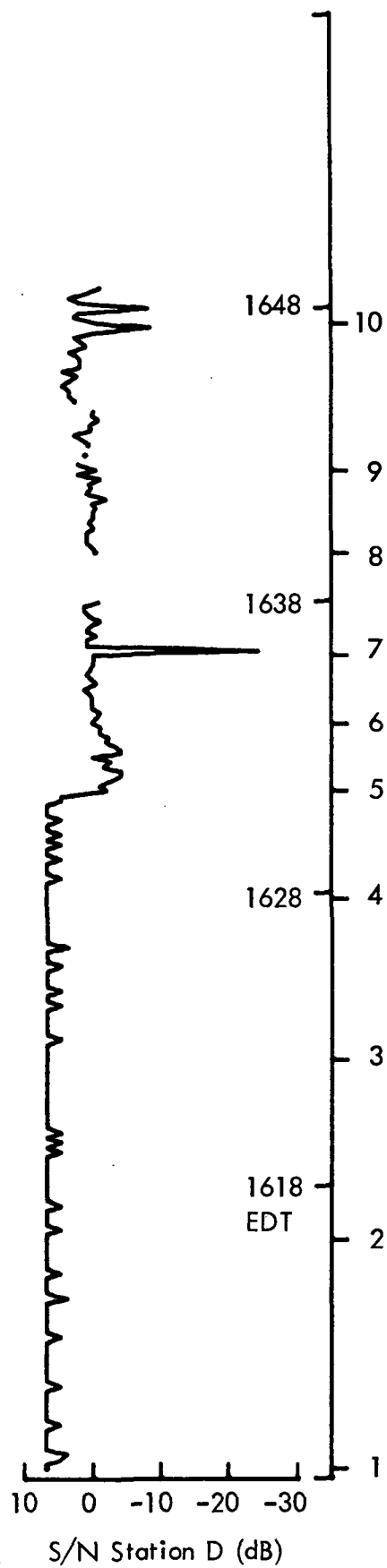
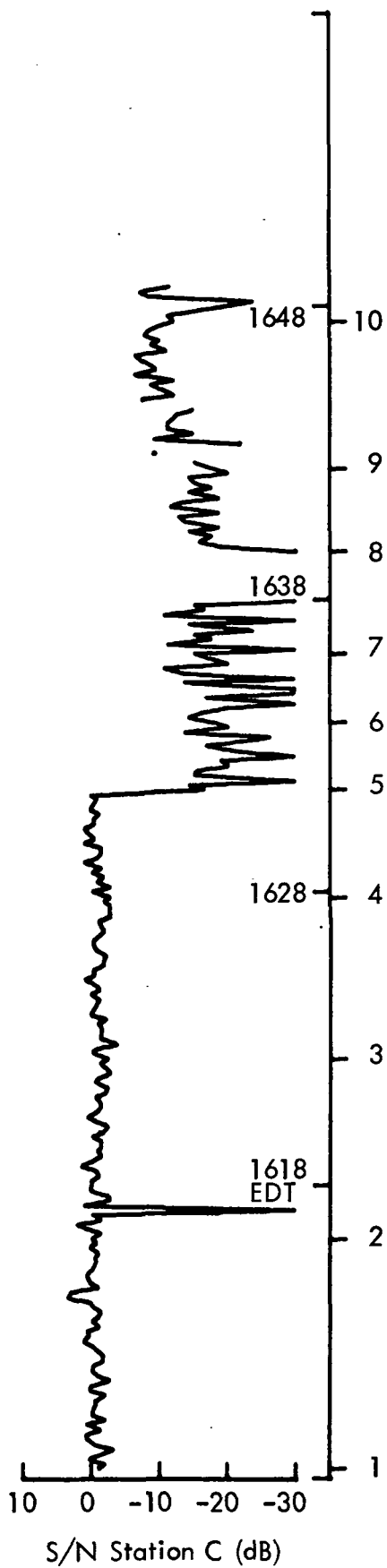

Figure B-96 . Flight 2-44 (Third 41 Min), S/N Station C and D;
 SBY-BED (Z1), 3/9/75, 5500' (Over TCA), 1330-1646 EDT, 1730-2046 GMT.

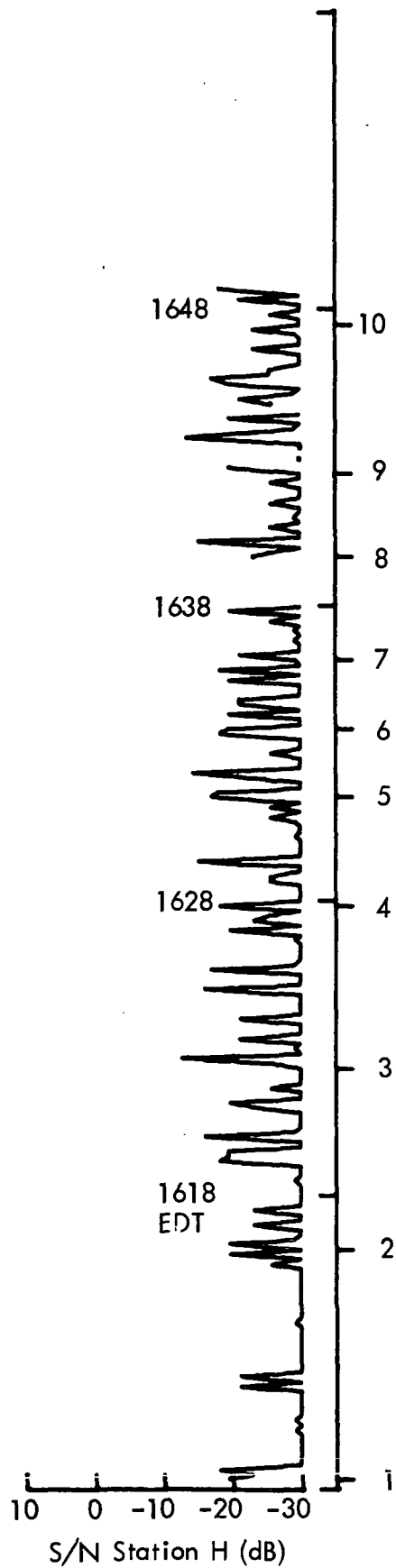

Figure B-97 . Flight 2-44 (Third 41 Min), S/N Station H;
 SBY-BED (Z1), 3/9/75, 5500' (Over TCA), 1330-1646 EDT, 1730-2046 GMT.

APPENDIX C

DATA REDUCTION SOFTWARE

APPENDIX C

DATA REDUCTION SOFTWARE

C.1 INTRODUCTION

Many programs were written for data processing and flight planning under this contract; nine of these ultimately were used. The original set of data processing software was designed to process Omega data and radar tracking data together, but due to hardware failures within the CIU and scheduling difficulties with the Wallops FPS-16 tracking radar, no flight test data was available with both tracking radar and Omega data. In order to speed processing for the simpler requirements, the SNPLOT series evolved.

C.2 PROGRAM LOPFMLL

In order to calculate Omega lines of position for the various checkpoints used in the flight tests, a Fortran subroutine was acquired from Dynell. This subroutine assumes an elliptical earth model and does no correcting for diurnal effects or surface conductivity variations.

Program LOPFMLL consisted of the Dynell subroutine translated to Basic for use on the ASI processor and the appropriate control code for input and output.

C.3 PROGRAM LLFMLOP

Program LLFMLOP calculates latitude and longitude of a point specified by two Omega LOPs.

C.3.1 PROGRAM DESCRIPTION

The program works by calculating the LOPs of an initial lat/lon guess,

calculating the gradient of latitude and longitude with respect to Omega lines of position, and updating the estimate of latitude and longitude with the gradient and the difference in LOP. This procedure is iterated to obtain sufficient accuracy. The workings of the program are shown in Figure C-1.

At the start of the program, all variables were dimensioned, the Omega station latitudes and longitudes read in, the first guess at latitude and longitude set, and the letters of the Omega stations being used read in. The Omega station letters were converted to numbers for use in indexing the station latitude and longitude array. The LOPs to be converted to latitude and longitude were read in, completing the initialization. Program LOPFMLL is called as a subroutine, yielding the Omega LOPs of the current estimate of latitude and longitude.

A linearized matrix for converting changes in LOP to changes in latitude and longitude was computed from the directions to the four stations in use. This routine is discussed in the next section. The difference in LOP between that of the current point and that inputted to the program is then inputted to the matrix to give the change in latitude and longitude, which is added to the old estimate of latitude and longitude to get a new estimate. If the linearization was made over one lane or less, the program prints out the latitude and longitude and asks for the next pair of LOPs to be converted. Otherwise, the program continues to iterate.

C.3.2 DERIVATION OF GRADIENT MATRIX

Using stations A and B for an example, the Omega A-B line of position for a given point is:

$$\text{LOP} = 900 + (\text{distance from point to A}) - (\text{distance from point to B})$$

The unit of distance and LOP is a wavelength. A change in LOP of 1 wavelength is called a lane, and along the baseline, one lane corresponds to a distance change of 1/2 wavelength.

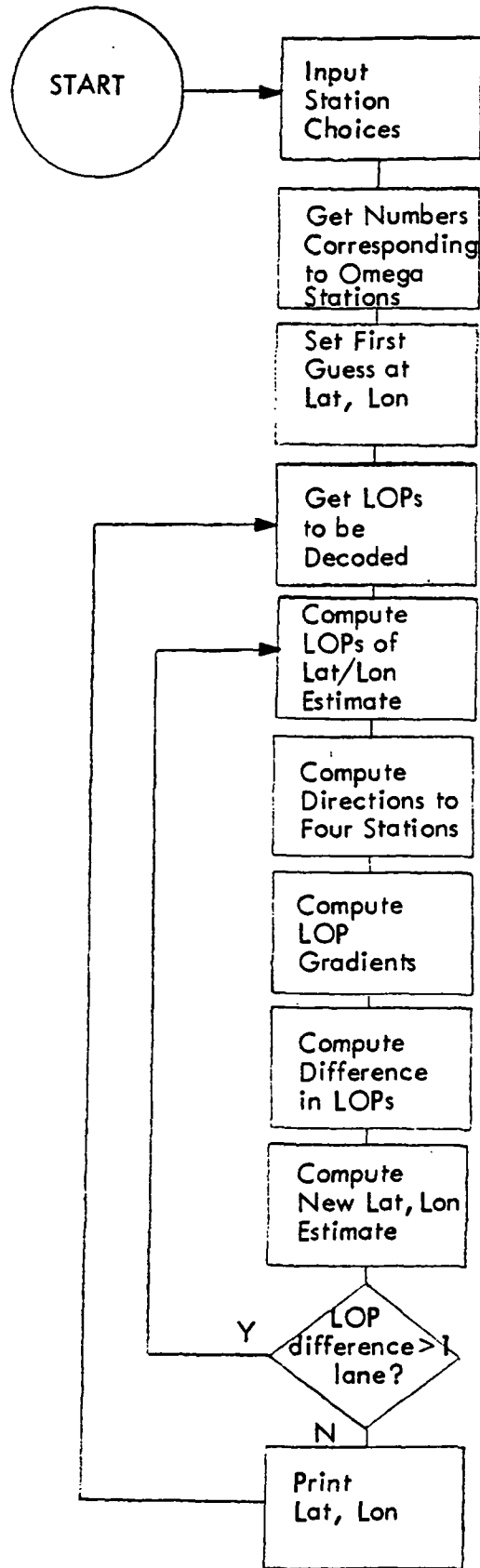

Figure C-1. Program LLMLOP Flowchart.

If a and b are unit vectors pointing to stations A and B, the unit vector d which maximizes change in LOP satisfies

$$\max \{ \langle d, a \rangle - \langle d, b \rangle \} = \max \langle d, a - b \rangle$$

Clearly, $d = \frac{a - b}{\|a - b\|}$. The direction of constant lines of position is perpendicular to this.

The spacing of lines of position one lane apart is $\frac{\lambda}{\|a - b\|}$. Thus, if we move in the direction d with magnitude $\frac{\lambda}{\|a - b\|}$, the change of LOP is

$$\begin{aligned} \Delta \text{LOP} &= \left\langle \frac{\lambda}{\|a - b\|} d, a - b \right\rangle \\ &= \lambda \left\langle \frac{d}{\|a - b\|}, a - b \right\rangle \\ &= \lambda \left\langle d, \frac{a - b}{\|a - b\|} \right\rangle \\ &= \lambda \langle d, d \rangle = \lambda \end{aligned}$$

Thus, the change in LOP is one lane.

If we want to change LOP 1 while keeping LOP 2 constant, clearly we must move along LOP 2, but the question is how far? Let us refer to Figure C-2. Two lines of position specified by station pair 1, vector K_1 and a perpendicular unit vector L_1 along the direction of LOP 1 are drawn. Similar LOPs and vectors are drawn for station pair 2. Also the vector M_1 of change in LOP 1 along LOP 2 is drawn. We must determine the length and direction of M_1 .

Let θ be the angle between M_1 and K_1 . Now, $\|M_1\| \cos \theta = \|K_1\|$. We know K_1, L_2 . We also know that if $\langle K_1, L_2 \rangle$ is negative, L_2 and M_1 point in opposite directions. Let us assume for the moment, that unlike our diagram $\langle K_1, L_2 \rangle > 0$. Thus

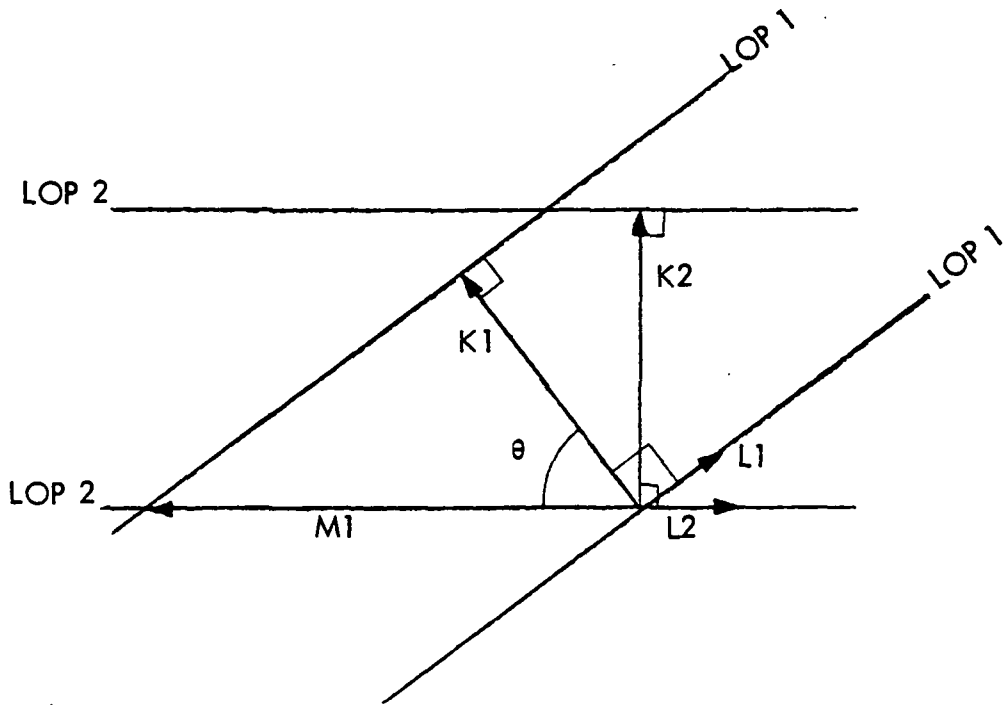

Figure C-2. LOP Geometry.

$$\begin{aligned} \langle L2, K1 \rangle &= \|L2\| \cdot \|K1\| \cdot \cos \theta \\ &= \|K1\| \cos \theta \end{aligned}$$

or

$$\cos \theta = \frac{\langle L2, K1 \rangle}{\|K1\|}$$

Now

$$M1 = \|M1\| \cdot L2$$

and

$$\|M1\| = \frac{\|K1\|}{\cos \theta} = \frac{\|K1\|^2}{\langle L2, K1 \rangle}$$

so

$$M1 = \frac{\langle K1, K1 \rangle}{\langle L2, K1 \rangle} L2 \quad (\text{based on the assumption that } \langle K1, L2 \rangle > 0.)$$

It is clear from this expression that the assumption is superfluous. Thus, knowing M1, the change in latitude and longitude can be obtained by taking the north and west components of M1 and multiplying by the change of LOP 1, with appropriate scale conversion factors.

C.4 PROGRAM TRNSFR7+ (See also Section 6.2)

TRNSFR7+ was the basic program used for reading data in from the CIU and writing it on the processor cassettes via the intermediate step of storage in memory. Because the processor was fairly slow, no data processing could be undertaken while data was being read (in real time). To store an entire CIU generated cassette (30 minutes of flight data) in memory at once, which was desirable to speed overall data processing, the program had to be optimized to allow sufficient memory for data storage. These requirements led to TRNSFR7+, which is flowcharted in Figure C-3.

Data was read continuously into memory at the start of the program in a loop. Due to speed constraints only loop maintenance parameters were generated. Each character string ended with a carriage return, which was sensed by the instruction which read in the character string. Thus, no character counting or detection was required by the program. Overlength strings could result, however, if the carriage return character was garbled. This rare occurrence was usually combined with the appearance of other illegal characters, which provided the easiest way of detecting invalid strings. Overlength strings were truncated by the processor when the dimensioned string length was filled. Because memory constraints did not allow for over dimensioning string lengths, overlength strings resulted in lost data.

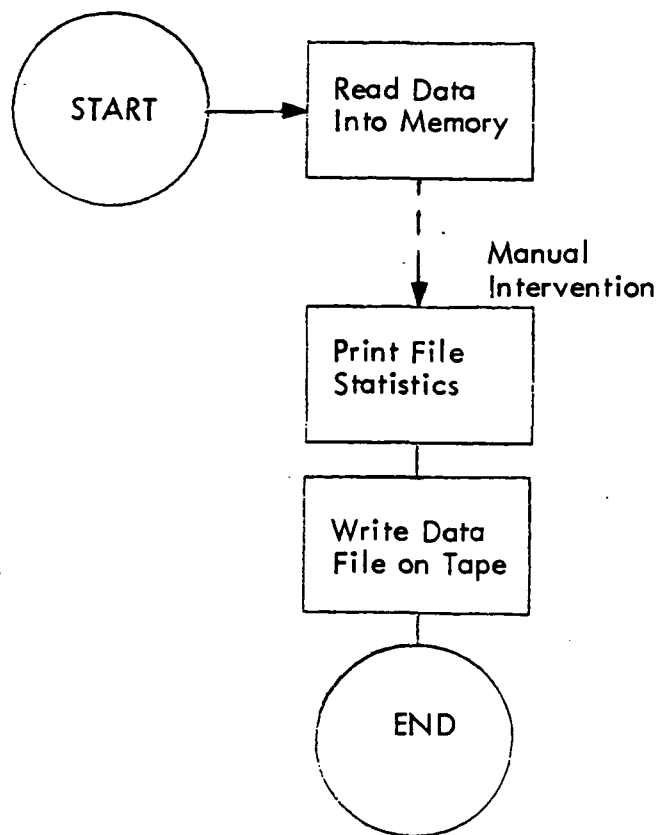

Figure C-3. Program TRNSFR7+ Flowchart.

At the conclusion of the real time data, if memory had not been filled, the program would be in a state of waiting for more data to be inputted. Manual intervention would be required to have the program write the collected data strings onto a processor cassette and print file parameters for the tape log. These parameters included the number of strings read and the number of records written on the processor cassette.

C.5 PROGRAM DATACHK (See also Section 6.3.2)

DATACHK was designed to detect data bits which are identically one or identically zero throughout one or more data files. This provided data validity information supplementary to that provided by TRNSCHK. DATACHK was a necessary but not sufficient check for good data.

The program flowchart is shown in Figure C-4. Four "registers" were maintained: those being occurrence of zero bits in the current file being read; occurrence

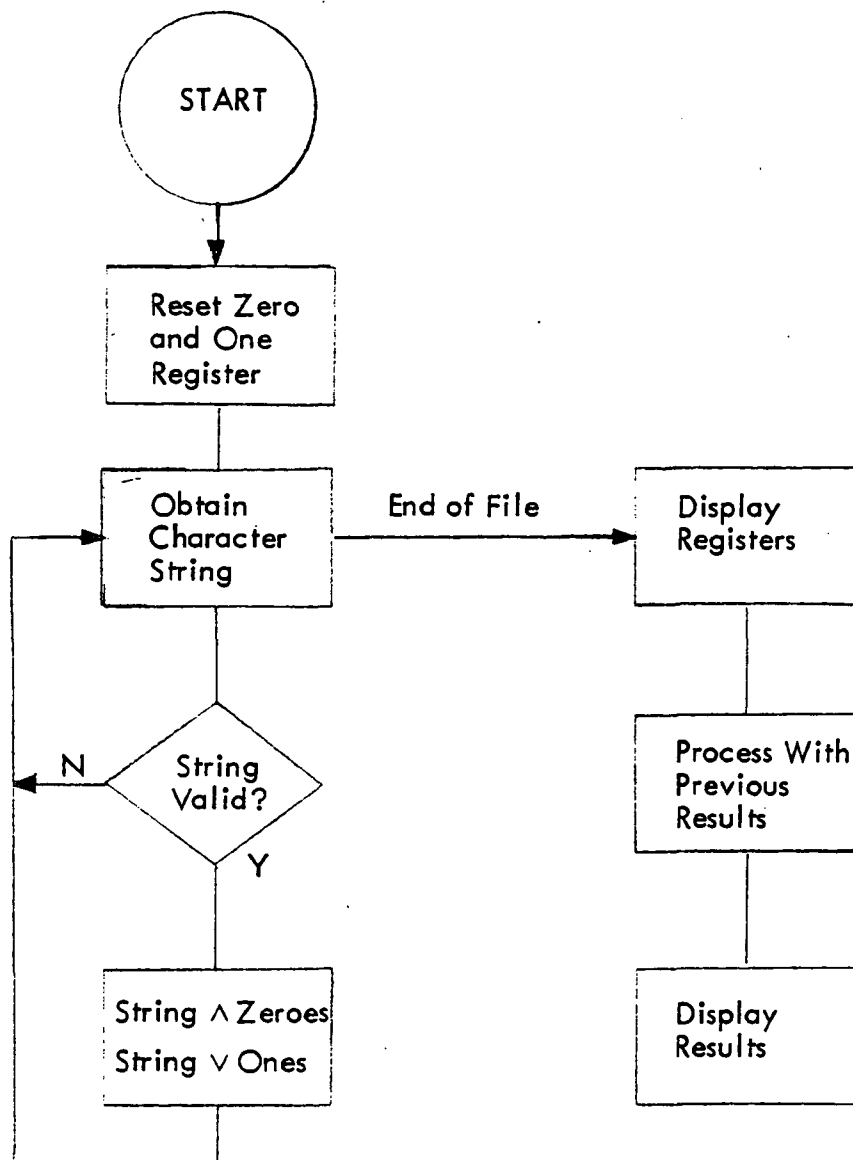

Figure C-4. Program DATACHK Flowchart.

of one bits in this file; and two manually reset registers, one each for one bits and zero bits. At execution, the registers for the "current" file were reset to all ones and all zeros.

As each character string was read from the data tape, it was checked for over- and under-length data strings and illegal characters. If present, a line feed character at the start of the data record was eliminated. Any invalid data strings were flushed.

Valid character strings were successively ANDed with the register set initially to all ones. Thus, the eventual occurrence of a bit being zero was detected. In a similar way, strings were successively ORed with a register set initially to all zeros in order to detect the eventual occurrence of a bit being one.

When all data strings in the file had been processed, the ones and zeros registers were displayed. Manual inspection revealed any data anomalies.

At the option of the user, the ones and zero registers for the present file could be ANDed and ORed with the manually reset registers, allowing bit patterns from earlier files to be processed with the current file data. This was done because not all bits were both zero and one during a single file.

C.6 PROGRAM TRNSCHK (See also Section 6.3.1)

TRNSCHK was written to confirm the quantity of data stored by the processor on cassettes. The program, flowcharted in Figure C-5, read data strings, usually thirty-one characters long, and displayed them on the processor CRT. In addition, the total number of records read was recorded for verification of tape log records.

No checking of data was done by the processor, but with practice, aberrant character strings were readily discerned by the user.

No error correction capability was written into the program.

C.7 PROGRAMS SNPLOTB AND SNPLOTD

Because the plotting of data excerpted from invalid data strings can depreciate the quality of the plots, it was necessary to filter out invalid strings. With each valid data string supplying information for four to eight plots, inline filtering of invalid data strings would have been excessively time consuming. For this reason,

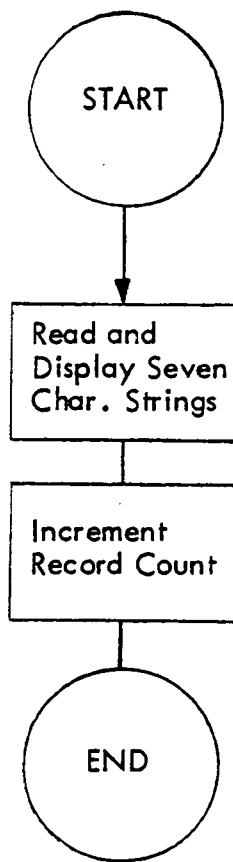

Figure C-5. Program TRNSCHK Flowchart.

SNPLOTB was written to filter out invalid character strings, and to provide as an output, a file of character strings containing only those parameters which were to be plotted. As plotting requirements changed, SNPLOTD was written, identical to SNPLOTB except for the selection of parameters supplied to the output character strings.

Figure C-6 shows the flowchart for SNPLOTB and SNPLOTD. Because several files were often concatenated for plotting, it was necessary to specify the number of the first string. This number was requested from the user during the initialization stage of the program. Similarly, if two files overlapped, it was necessary to skip the first few strings of the second file. The number of strings to be skipped was also inputted.

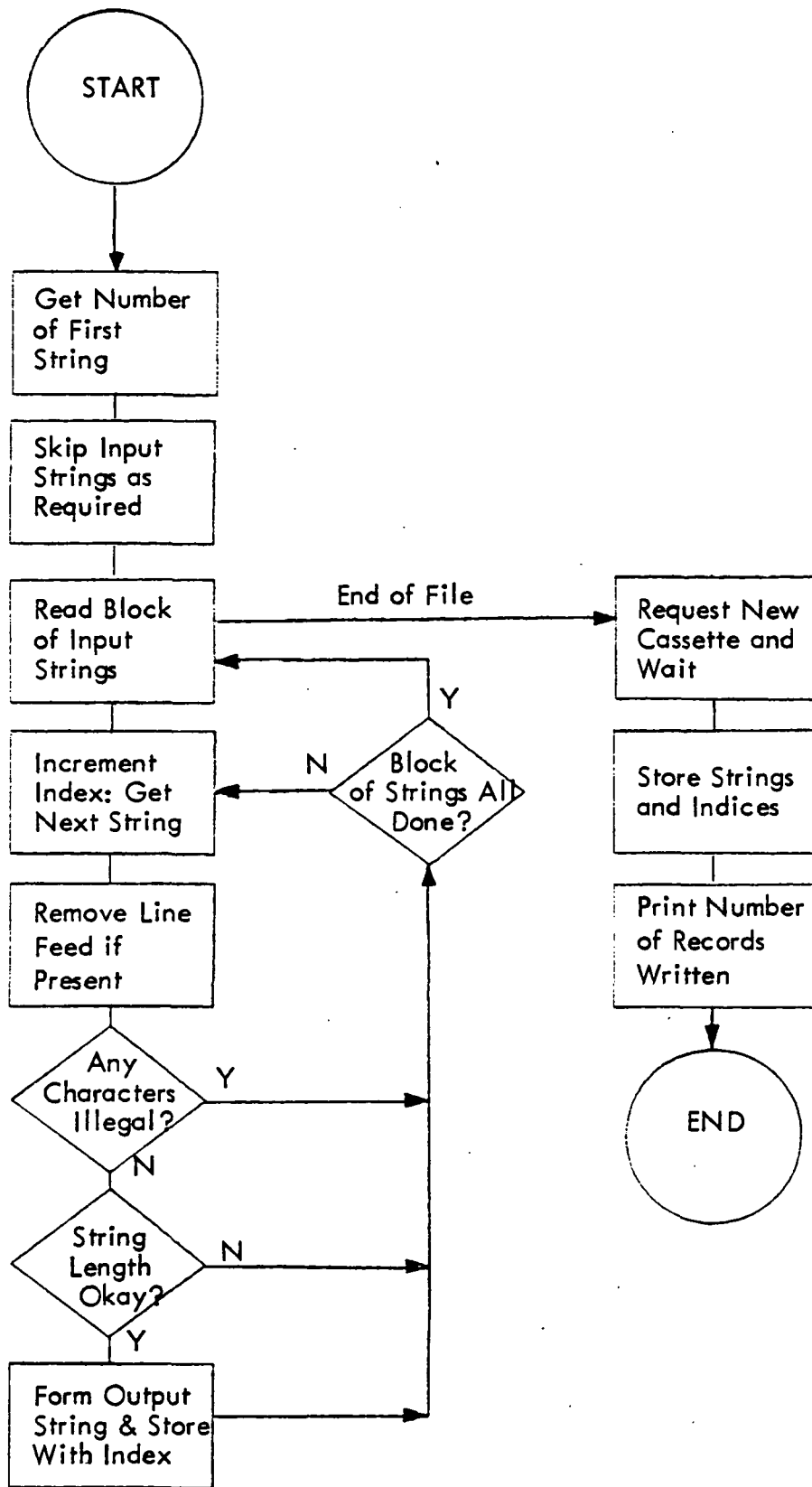

Figure C-6. Programs SNPLOTB and SNPLOTD Flowchart.

Unfiltered data strings were stored in blocks of seven on the input cassette. Logic was provided to sequentially select strings from these blocks, and to read a new block of strings when required. As each string was selected, the index counter was incremented. If the string consisted only of legal characters (after removal of a line feed character, if one was present), and if the string met length criteria, the index and that part of the string containing the desired data were stored in memory. Otherwise, the string was removed and a new string selected. Invalid strings also incremented the index so that timing information loss was minimized. At the end of the file, the program requested a fresh cassette, and the vector of string portions and their indices was written onto the new cassette. This cassette was used as input to the plotting routines. File statistics were generated for tape management purposes.

C.8 PROGRAM SNPLOT

SNPLOT was written to plot S/N ratios and needle deflections versus time and changes in the operator discrete code. This program accepts the files generated by SNPLOTB as inputs. The program flowchart is Figure C-7.

The basic program was straightforward. The number of points to be plotted was requested for determination of x axis scaling. The axes were drawn according to the selection of what was to be plotted. S/N ratios were drawn on "L" shaped axes, and S/N ratios were drawn on horizontal "T" axes. Time hacks were drawn every 60 data points, corresponding to 10 minutes of data.

Filtered data strings and their indices were read from the cassette in blocks of eight. The abscissa of the point was determined from the index, and the ordinate of the point was generated in one of two subroutines described below. If there was a change in the operator discrete code, a tick mark was drawn on the x axis. Points with successive indices were plotted with continuous lines whereas points with indices

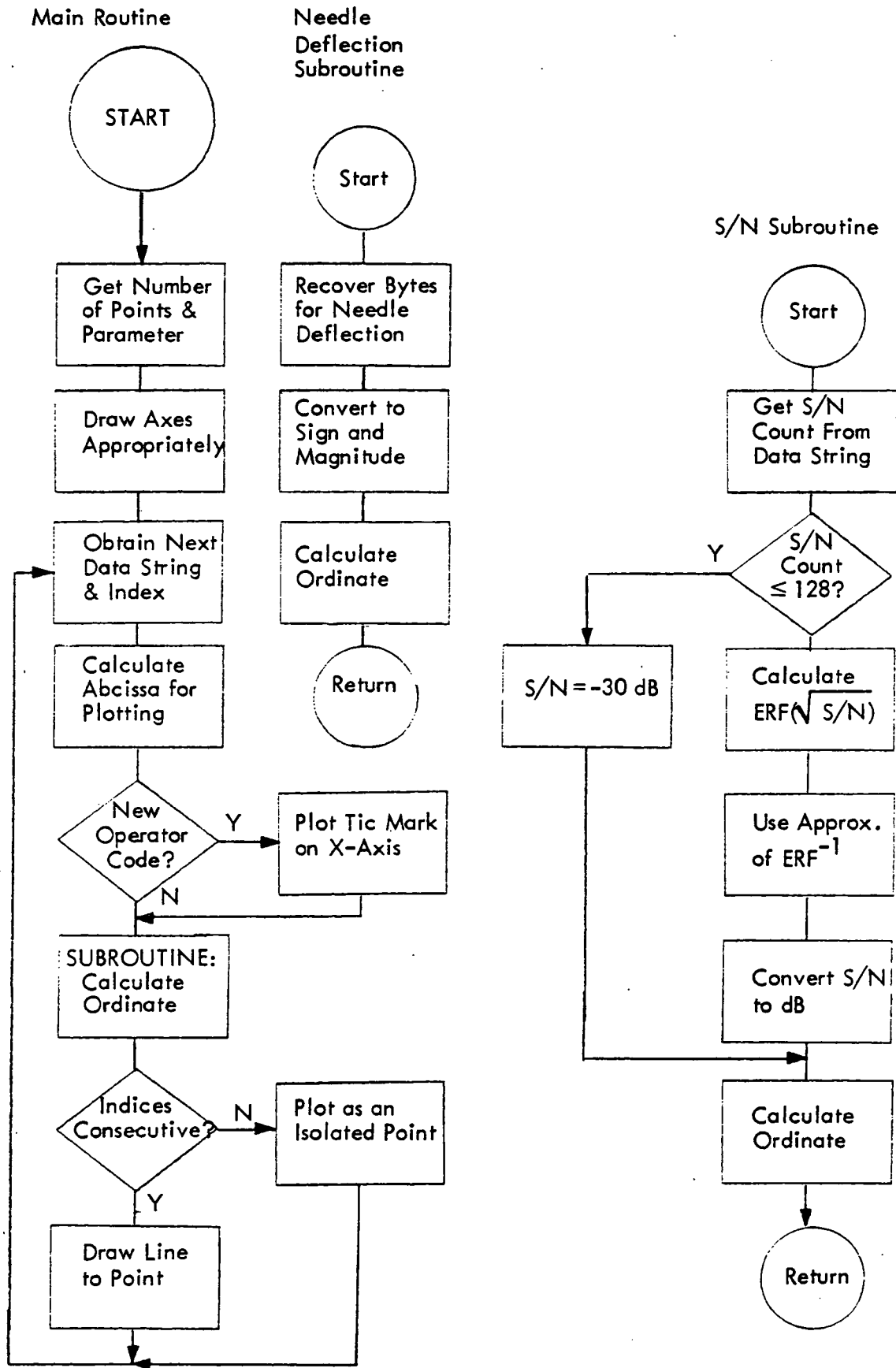

Figure C-7. Program SNPLOT Flowchart With Subroutines.

varying by more than one were not plotted continuously. Thus, plot segments with continuous lines can be assumed to originate from consecutive flight measurements.

C.8.1 S/N SUBROUTINE

As described in Section 6, the value of the Omega receiver S/N counter was derived from the observed S/N count by

$$\text{COUNT NUMBER} = 128 + 100 * (\text{broadcast time of Omega station}) \\ * \text{ERF} \left(\sqrt{\text{S/N power}} \right)$$

Figure C-7 shows the routine used to invert this equation to solve for the S/N ratio in terms of the S/N counter value. For plotting purposes, all S/N ratios were assumed to be at least -30 dB, even though the station in question may not have even been transmitting when the measurements were being made. If the S/N counter was greater than 130, the S/N ratio was above -30 dB. In this case, the error function of the square root of the S/N ratio was calculated. The error function inverse was calculated using an approximation (Reference 13) with sufficient accuracy. The S/N ratio was calculated in dB and the appropriate ordinate computed.

C.8.2 NEEDLE DEFLECTION SUBROUTINE

Needle deflections were recorded by the CIU as a sign bit plus seven bits of magnitude. The needle deflection subroutine decoded these data from the data strings and interpreted the data as a number between -1 and +1. This number was then plotted on a linear scale referenced by horizontal line indicating needle centered and tick marks representing needle deflection in fourths of full scale deflection each direction.

C.9 PROGRAM SNPLOTE

SNPLOTE was an adaption of SNPLOT designed to plot miles to go and

status flags. The horizontal control of the plotter was identical to that utilized in SNPLOT, as was all the data management. SNPLOTE, however, plotted the data in two passes. This program is flowcharted in Figure C-8.

On the first pass, the status flags were plotted. The to/from flag was plotted as a continuous line, subject to breaks in the data, and the reset, autozero, and weak signal flags appeared as tick marks in separate rows between the to/from flag and the x axis. As in other plots, the x axis has tick marks every 60 data points and at the first occurrence of a new operator discrete code.

After all status flags had been plotted, the data tape was rewound and the miles to go readout was plotted on a linear scale of 0-75 miles with tick marks in 25 mile steps.

C.10 PROGRAM WALPLOT

WALPLOT was a specialized routine for plotting position as recorded by the Omega receiver lane accumulators. WALPLOT converted the lane accumulator values to changes in latitude and longitude from the reset point, and automatically invoked new parameters when a "Reset" flag was encountered. In addition, WALPLOT contained a simple filter to reduce noise in the plots. The program is flowcharted in Figure C-9.

WALPLOT began with parameter initialization and selection of user options. These options included plotting of raw or filtered data, and provision for plotting all or part of the data. A counter was set indicating the first pass of the program over the data.

Data strings generated by SNPLOT were used. The values of the two LOP accumulators were decoded, and the change in latitude and longitude from the reset

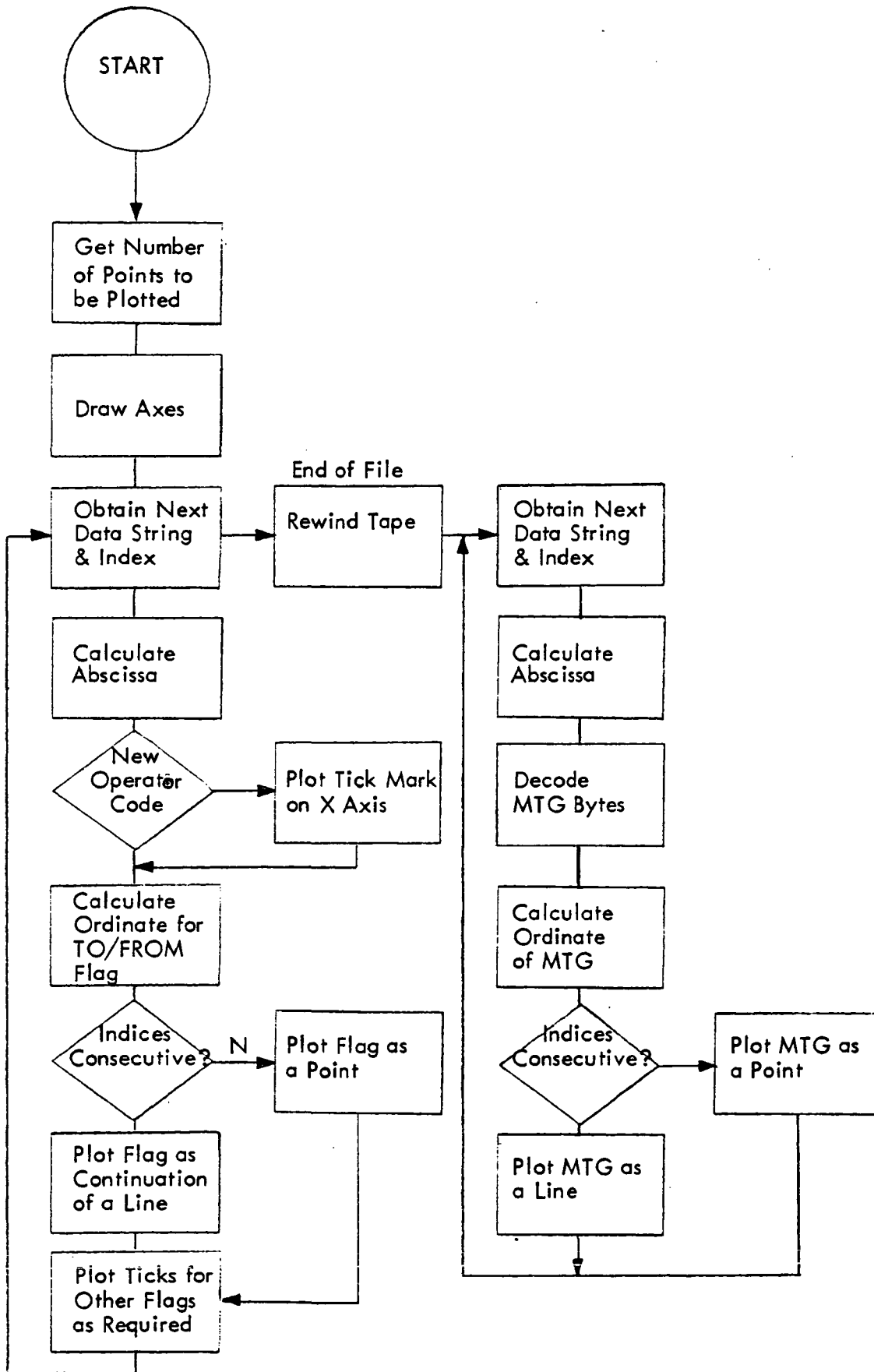

Figure C-8. Program SNPLOTE Flowchart.

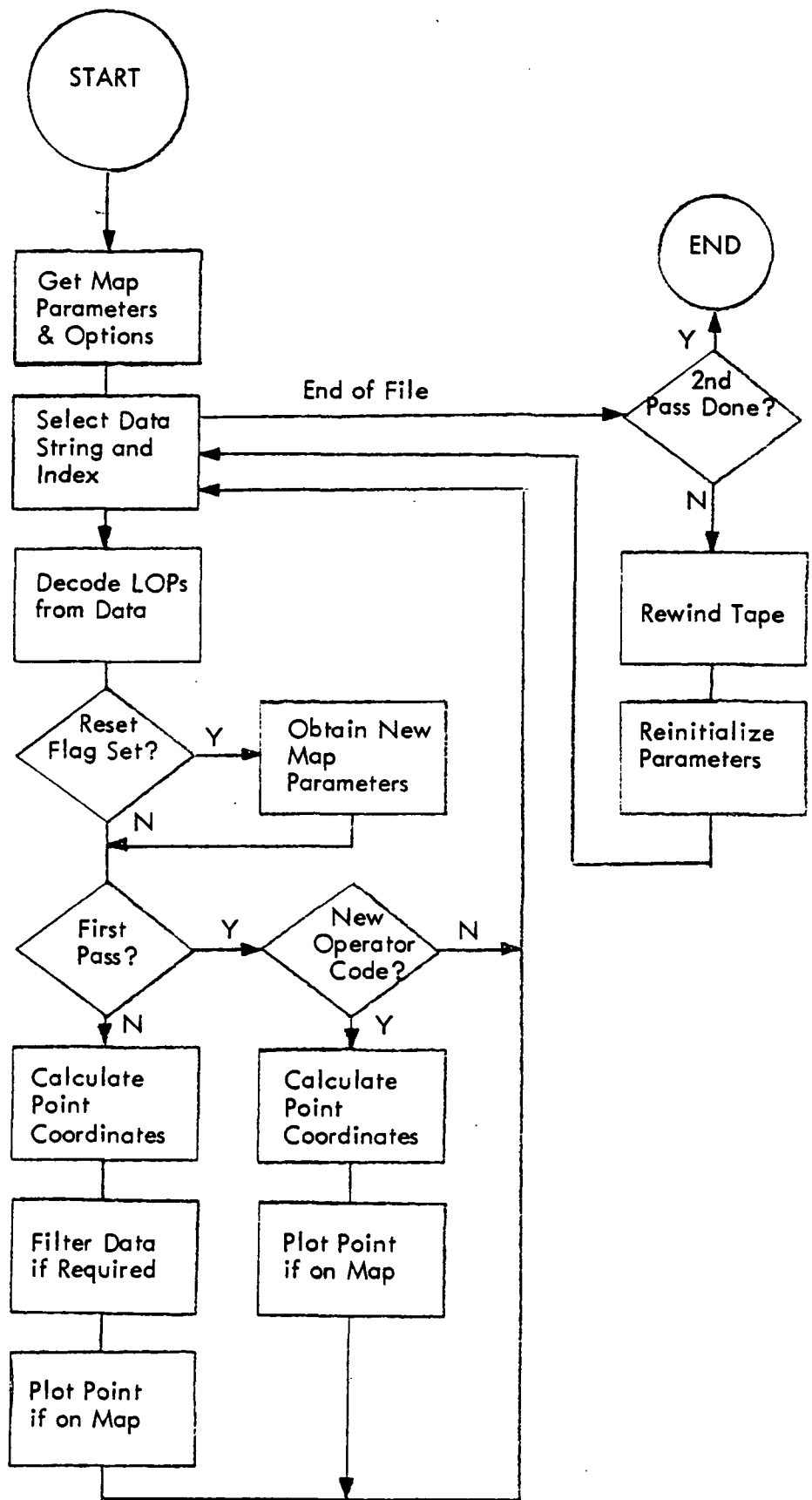

Figure C-9. Program WALPLOT Subroutine.

point was calculated using the linearization section of LLFMLOP. The plotter XY commands were calculated for plotting on a Mercator projection map.

The smoothing filter, if selected by the user, modified the plotter commands in the following manner. First, the new plotter commands were fed into a software shift register which provided storage of filter states. If the plotter commands were not sequential as measured by the data string index, data would be shifted into the filter more than once so that the most recent raw data point was also used to replace missing data points. The filter itself consisted of a linear combination of the five filter states as shown in Figure C-10. This is a finite duration step response filter with an equivalent time constant of about 20 seconds. The filter was designed for smoothing

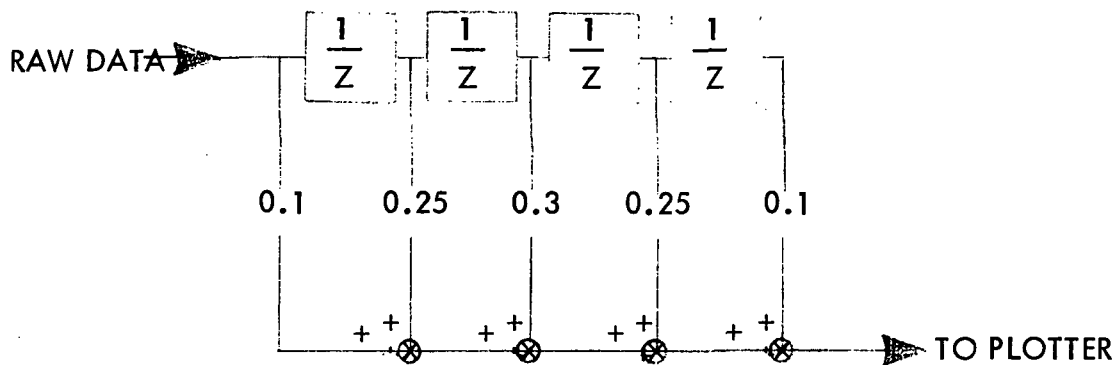

Figure C-10. Data Filter.

map plots, and does not necessarily represent an optimal Omega filter. Due to the linearity of the filtering and data processing, filtering the plotter commands was equivalent to plotting data from an airborne Omega data filter. Additional coding was written so that the plotter would not attempt to plot points off the map, but would leave a break in the plot.

On the first pass of the program over the data, if the filter was not selected, only those points representing the first occurrence of a changed operator discrete code would be plotted. After these points were plotted, the program would stop execution

to allow the user to circle these points with a pencil. When execution was continued, the program plotted the raw data, which appeared as a series of jagged lines. The circled points were thus identifiable as representing changes of operator discrete code.

Additional code was written to allow the user to specify what portion of the data was to be processed.

APPENDIX D

CUSTOM INTERFACE UNIT (CIU) DATA FORMAT

APPENDIX D

CUSTOM INTERFACE UNIT (CIU) DATA FORMAT

This appendix summarizes the data formats utilized by the special purpose CIU designed and fabricated for the Omega flight evaluation program.

D.1 CHARACTER SEQUENCE

A complete data string is stored in real time every Omega broadcast cycle, i.e. once each 10 seconds. The character sequence is shown in Table D-1.

Table D-1. CIU Character Sequence.

<p>1. STA E S/N LS byte</p> <p>2. STA E S/N MS byte</p> <p>3. STA F S/N LS byte</p> <p>4. STA F S/N MS byte</p> <p>5. STA G S/N LS byte</p> <p>6. STA G S/N MS byte</p> <p>7. STA H S/N LS byte</p> <p>8. STA H S/N MS byte</p> <p>9. STA A S/N LS byte</p> <p>10. STA A S/N MS byte</p> <p>11. STA B S/N LS byte</p> <p>12. STA B S/N MS byte</p> <p>13. STA C S/N LS byte</p> <p>14. STA C S/N MS byte</p> <p>15. (P-S)LOP 1 LS byte</p> <p>16. (P-S)LOP 1 LS byte</p>	<p>17. (P-S)LOP 1 LS byte</p> <p>18. (P-S)LOP 1 MS byte</p> <p>19. (P-S)LOP 2 LS byte</p> <p>20. (P-S)LOP 2 LS byte</p> <p>21. (P-S)LOP 2 LS byte</p> <p>22. (P-S)LOP 2 MS byte</p> <p>23. FLAGS</p> <p>24. STA D S/N LS byte</p> <p>25. STA D S/N MS byte</p> <p>26. Miles to go LS byte</p> <p>27. Miles to go LS byte</p> <p>28. Miles to go MS byte</p> <p>29. Xtrk error LS byte</p> <p>30. Xtrk error MS byte</p> <p>31. Operator discrete</p> <p>32. Carriage return</p> <p>33. Line feed</p>						
<table style="width: 100%; border: none;"> <tbody> <tr> <td style="width: 50%;">LS = Least Significant</td> <td style="width: 50%;">LOP = Line-of-Position</td> </tr> <tr> <td>MS = Most Significant</td> <td>S/N = Signal/Noise Ratio</td> </tr> <tr> <td>(P-S) = Present Minus Start</td> <td></td> </tr> </tbody> </table>		LS = Least Significant	LOP = Line-of-Position	MS = Most Significant	S/N = Signal/Noise Ratio	(P-S) = Present Minus Start	
LS = Least Significant	LOP = Line-of-Position						
MS = Most Significant	S/N = Signal/Noise Ratio						
(P-S) = Present Minus Start							

NOTE: The data reduction computer can be programmed to recognize characters 32 and 33 as end of data block indication.

D.2 CHARACTER FORMAT (1 = mark, 0 = space)

- Data Character (characters 1 - 31)

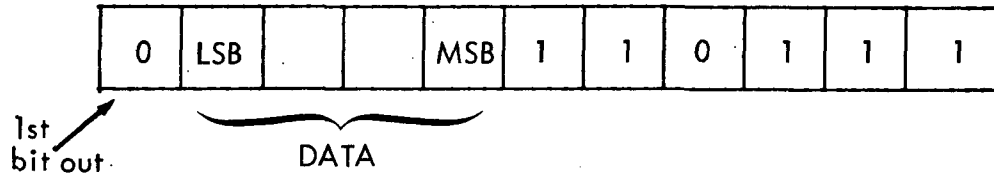

- Carriage Return Character (character 32)

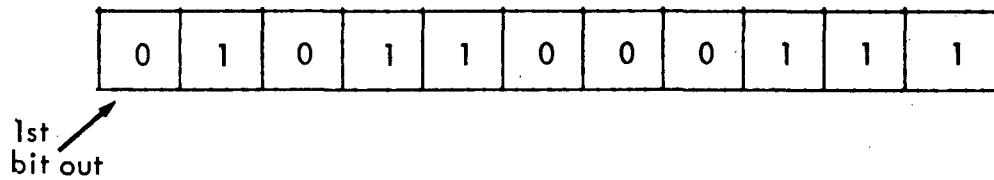

- Line Feed Character (character 33)

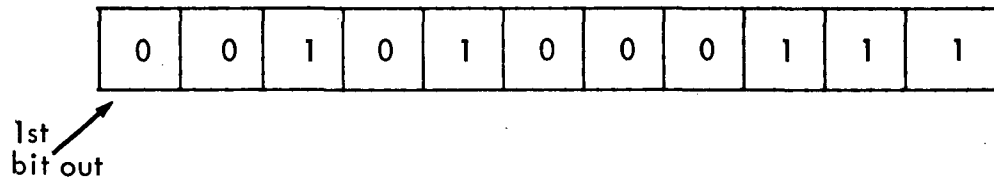

NOTE: All "non-character" tape time filled with marks.

D.3 DATA FORMAT

- S/N Data (8 bits binary in 2 bytes)
Figure D-1 shows the S/N vs binary number.
- Miles to Go (12 bits binary in 3 bytes)
least significant bit = 1 mile

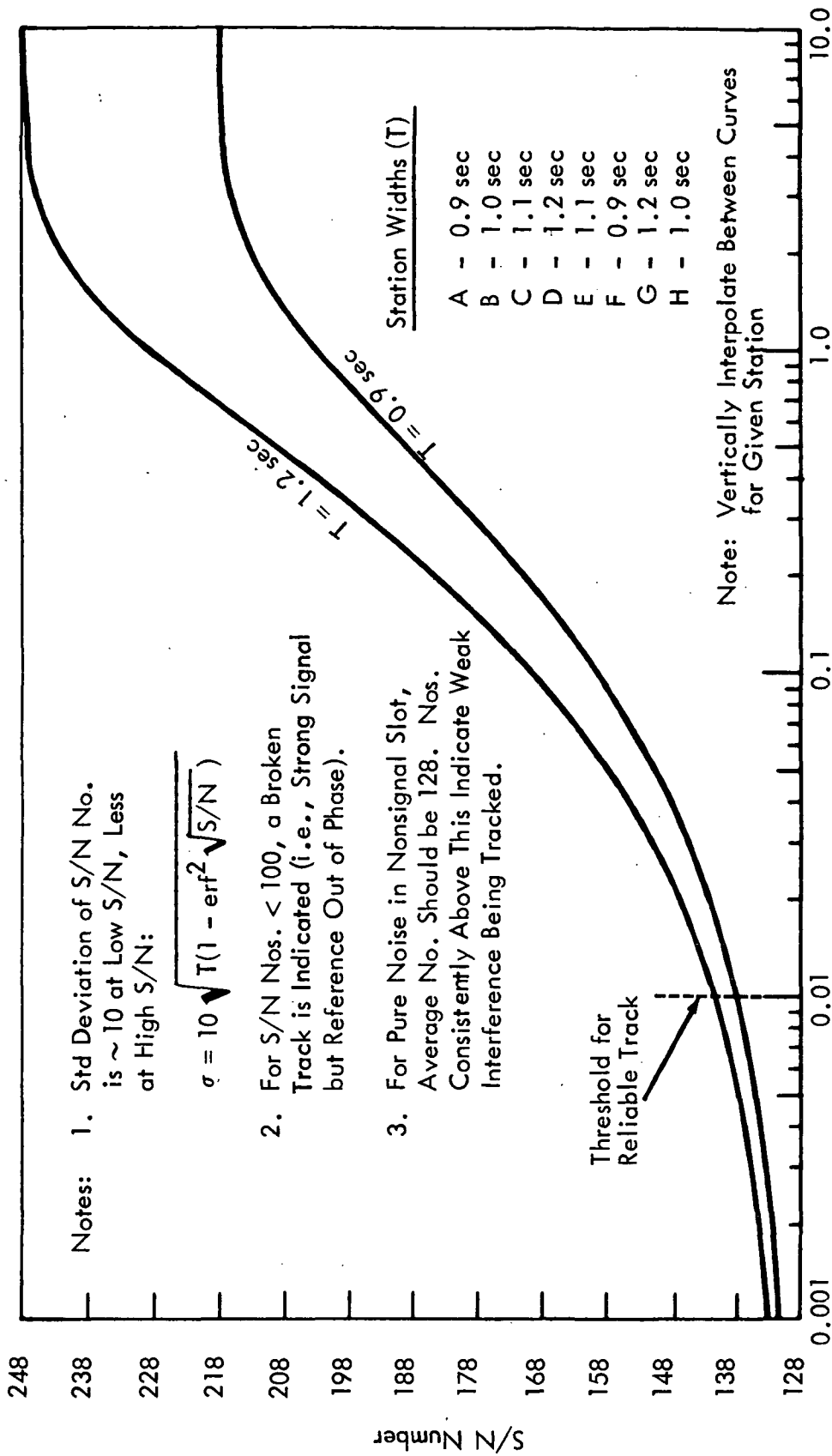

Figure D-1. CIU S/N Data.

- Xtrk Error (8 bits binary in 2 bytes)

most significant bit = sign

i.e. 0 = right of course line

1 = left of course line

remaining bits = magnitude of error = X

$$\text{XTRK ERROR (MILES)} = \frac{X}{120} \frac{M_2 |\cos \theta_1| + M_1 |\cos \theta_2|}{|\sin(\theta_1 - \theta_2)|}$$

where: M_1 = LOP 1 lane width (miles)

M_2 = LOP 2 lane width (miles)

θ_1 = angle between LOP 1 normal and course

θ_2 = angle between LOP 2 normal and course

- LOP from Origin (P-S)(16 bits binary in 4 bytes)

most significant bit = sign

i.e. 0 = wrong direction to destination

1 = proper direction to destination

remaining bits are magnitude

$$\text{LSB} = \frac{1}{256} \text{ of a lane}$$

- Flags (4 bits of data in 1 byte)

LSB = 1 → reset within last 10 seconds

next number = 1 → weak signal in last 10 seconds

next number = 1 → auto zero in last 10 seconds

MSB = 1 → FROM within last 10 seconds

MSB = 0 → TO for all last 10 seconds

- Operator Discrete (4 bits binary in 1 byte)
binary number 0 - 15 as set on thumbwheel switch