

JAN 8 1976

**NASA CR-137750**

(NASA-CR-137750)	DESIGN DEFINITION STUDY OF	N76-18102
	A LIFT/CRUISE FAN TECHNOLOGY V/STOL	
AIRPLANE: ADDENDUM	Final Report (Boeing	
Commercial Airplane Co., Seattle)	312 p HC	Unclas
\$9.75	CSCL 01C G3/05	09629

# DESIGN DEFINITION STUDY OF A LIFT/CRUISE FAN TECHNOLOGY V/STOL AIRPLANE – ADDENDUM

J. M. Zabinsky  
H. C. Higgins

Addendum Report  
August 15, 1975



Prepared under contract NAS2-6563

Boeing Commercial Airplane Company  
P.O. Box 3707  
Seattle, Washington 98124

for  
Ames Research Center  
NATIONAL AERONAUTICS AND SPACE ADMINISTRATION

1 Report No NASA CR 137750		2 Government Accession No		3 Report status (if any)	
4 Title and Subtitle DESIGN DEFINITION STUDY OF A LIFT/CRUISE FAN TECHNOLOGY V/STOL AIRPLANE - ADDENDUM REPORT				5 Report Date August 15, 1975	
				6 Distribution statement (if any)	
7 Author(s) J. M. Zabinsky, H. C. Higgins				8 Performing Organization Report No D6-42647	
9 Performing Organization Name and Address Boeing Commercial Airplane Company Seattle, Washington				10 Work Order No	
				11 Contract Number (if any) NAS2-6563	
12 Sponsoring Agency Name and Address NASA-Ames Research Center Moffett Field, California				13 Type of Report and Period Covered Final Report	
				14 Sponsoring Agency order	
15 Supplementary Notes TECHNICAL MONITOR B. A. LAMPKIN					
16 Abstract A two engine three fan V/STOL airplane was designed to fulfill naval operational requirements. A multi-mission airplane was developed from study of specific point designs. Based on the multi-mission concept, airplanes were designed to demonstrate and develop the technology and operational procedures for this class of aircraft. Use of interconnected variable pitch fans led to a good balance between high thrust with responsive control and efficient thrust at cruise speeds. The airplanes and their characteristics are presented.					
17 Key Words (Suggested by Author(s)) V/STOL PROPULSION VARIABLE PITCH			18 Distribution Statement UNCLASSIFIED - UNLIMITED		
19 Security Classif. (of this report) NONE		20 Security Classif. (of this page) NONE		21 No. of Pages	22 Price*

## FOREWORD

This document contains the work done under the amendment to NASA Contract NAS2-6563 for study of a Lift Cruise Fan Technology Airplane and Conceptual Design of a Navy Multi-Mission V/STOL Airplane. The arrangement of this report emphasizes these two phases of the study. The conceptual designs are described in Part I and the Technology Airplanes in Part II.

The ASW is the version of the multi-mission airplane which received the most detailed analysis. For that reason all the detailed design, philosophy and configuration development is described in Section 3.3, ASW Airplane Design.

Similarly, for Part II the design of the technology airplane is presented in detail in Section 4.1, the All New Aircraft. The discussion of the modified aircraft are presented without repeating areas which are common to the all new airplane.

## CONTENTS

	Page
1.0 SUMMARY .....	1
2.0 INTRODUCTION .....	12
3.0 PART I-NAVY OPERATIONAL AIRCRAFT .....	15
3.1 Point Design Aircraft .....	16
3.2 Multi-Mission Aircraft .....	33
3.2.1 Multi-Mission Summary .....	33
3.2.2 Multi-Mission Performance .....	35
3.3 ASW Airplane Design, Model 1041-133-1 .....	55
3.3.1 Arrangement and Characteristics (1041-133-1) .....	57
3.3.2 Internal Arrangement (1041-133-1) .....	60
3.3.3 Aerodynamic Characteristics (1041-133-1) .....	62
3.3.3.1 Lift and Drag Data .....	62
3.3.3.2 Performance .....	75
3.3.4 Structural Criteria and Design (1041-133-1) .....	81
3.3.5 Aircraft Systems (1041-133-1) .....	85
3.3.6 Propulsion (1041-133-1) .....	91
3.3.7 Drive System .....	99
3.3.8 Weights and Balance .....	101
3.3.9 Flight Controls .....	101
3.3.9.1 Control System Description .....	107
3.3.9.2 Control System Performance .....	114
4.0 PART II-LIFT/CRUISE FAN TECHNOLOGY AIRCRAFT .....	130
4.1 All New Aircraft, Model 1041-134 .....	131
4.1.1 Configuration .....	131
4.1.2 Propulsion .....	134
4.1.3 Aerodynamics .....	134
4.1.4 Flight Controls .....	144
4.1.5 Aircraft Systems .....	147
4.1.6 Weight and Balance .....	147
4.1.7 Performance-All New Airplane 1041-134 .....	151
4.2 Modified Aircraft Model 1041-135-2 .....	156
4.2.1 Configuration .....	156
4.2.2 Flight Controls .....	164
4.2.3 Weight and Balance .....	164
4.2.4 Performance .....	164
4.3 Modified Aircraft (Limited Flight Envelope) Model 1041-136 .....	165
4.4 Technology Aircraft Comparison Summary .....	167

PRECEDING PAGE BLANK NOT FILMED

## CONTENTS (Concluded)

APPENDICES	Page
A. Excerpts From Work Statement and Guidelines .....	169
B. Installed Propulsion Performance .....	187
C. Ground Effects .....	225
D. Inlet Aerodynamics .....	229
E. Fan Nozzle Vanes .....	253
F. Transmission Spiral Bevel Gear Load and Velocity Experience .....	259
G. HLH Transmission Gearing Experience .....	265
H. Takeoff and Landing Time Histories .....	275
I. Weight Analysis Method .....	281
J. Maximum Lift, Speed and Nacelle Deflection Characteristics for the 1041-133-1 .....	291

## FIGURES

No.		Page
1.0-1	Hierarchy of Designs .....	2
1.0-2	1041-133 V/STOL Aircraft .....	3
1.0-3	Point Designs .....	5
1.0-4	All New Technology Airplane, Model 1041-134 .....	8
1.0-5	Modified T-5J Technology Airplane, Model 1041-135-2 .....	11
2.0-1	ASW Mission Performance .....	13
3.1-1	Point Design, Three Fan Two Engine ASW Airplane, LCFA-128 .....	17
3.1-2	Trimmed Drag Polar LCFA 1041-128 (ASW) .....	18
3.1-3	Surveillance Airplane, LCFA-129 .....	19
3.1-4	Trimmed Drag Polar LCFA 1041-129 (Surveillance) .....	20
3.1-5	VOD Airplane, Three Engines, LCFA-130 .....	21
3.1-6	VOD Three Engine Transmission .....	22
3.1-7	VOD Airplane, Cabin Arrangement .....	23
3.1-8	Trimmed Drag Polar LCFA 1041-130 (VOD) .....	24
3.1-9	Surface Attack Airplane, LCFA 131 .....	25
3.1-10	Trimmed Drag Polar LCFA 1041-131 (SA) .....	26
3.1-11	CSAR, LCFA-132 .....	27
3.1-12	Trimmed Drag Polar LCFA 1041-132 (CSAR) .....	28
3.2-1	ASW Airplane, Model 1041-133-1 .....	37
3.2-2	Trimmed Drag Polar .....	38
3.2-3	Multimission Airplane Surveillance Role, Model 1041-133-2 .....	39
3.2-4	LCFA 133-2 Surveillance Rotodome and Support Strut Drag .....	
3.2-5	Mission Breakdown LCFA 1041-133-2 (Surveillance) .....	41
3.2-6	Performance Capability, Model 1041-133-2 .....	42
3.2-7	Multimission Airplane, VOD Role, 1041-133-3 .....	43
3.2-8	Trimmed Drag Polar LCFA Configuration; 133-3 (VOD) .....	44
3.2-9	Mission Breakdown LCFA 1041-133-3 (VOD) .....	
3.2-10	Performance Capability, Model 1041-133-3 .....	46
3.2-11	Multimission Airplane Attack Role, Model 1041-133-4 .....	47
3.2-12	LCFA 133-4 (SA) External Store Drag .....	48
3.2-13	Mission Breakdown LCFA 1041-133-4 (SA) .....	49
3.2-14	Performance Capability, Model 1041-133-4 .....	50
3.2-15	Multimission Airplane CSAR Role, Model 1041-133-5 .....	51
3.2-16	Mission Breakdown LCFA 1041-133-5 (CSAR) .....	52
3.2-17	Performance Capability, Model 1041-133-5 .....	53
3.3-1	Propulsion Arrangements for Thrust Vectoring .....	56
3.3.1-1	General Arrangement, Model 1041-133 .....	58
3.3.1-2	Spotting Comparison .....	59
3.3.2-1	Inboard Profile of Model 1041-133-1 ASW Airplane .....	61
3.3.2-2	Area Distribution, Model 1041-133-1 .....	64
3.3.2-3	Alternate Fan Drive System, Model 1041-133-1 (ASW Airplane) .....	65
3.3.3-1	Reynolds Number Skin Friction Correction 1041-133-1 (ASW) .....	67
3.3.3-2	Drag Breakdown 1041-133-1 (ASW) .....	68

## FIGURES (Continued)

		Page
3.3.3-3	Oswald Efficiency Factor LCFA 1041-133 (ASW) .....	69
3.3.3-4	Buffet Boundary $Cl_{LB}$ .....	70
3.3.3-5	Lift Characteristics 1041-133-1 (ASW) .....	71
3.3.3-6	External Store Drag 1041-133-1(ASW) .....	72
3.3.3-7	Trimmed Drag Polar 1041-133-1 (ASW) .....	73
3.3.3-8	V/STOL Configuration Polar 1041-133-1 (ASW) Out of Ground Effect ....	74
3.3.3-9	STO Time History, 1041-133-1 (ASW) .....	76
3.3.3-10	STO Mission Breakdown LCFA-1041-133 (ASW) .....	78
3.3.3-11	VTO Mission Breakdown LCFA 1041-133-1 (ASW) .....	79
3.3.3-12	Model 1041-133 Flight Envelope .....	80
3.3.4-1	Structural Speed-Altitude Envelope .....	83
3.3.4-2	V-n Diagrams .....	84
3.3.4-3	General Structural Arrangement	
	Engine Support and Rotation Mechanism ..	86
3.3.4-4	Schematic of Services (Fuel, Electric, Bleed) to Pivot Beam .....	87
3.3.4-5	Section Through Outer Bearing .....	88
3.3.6-1	Cruise/Lift Fan/Engine Propulsion Pod .....	93
3.3.6-2	Advanced T701 Compound Lift/Cruise Turbofan Turboshaft Engine .....	97
3.3.6-3	Variable Geometry Inlet Model .....	98
3.3.7-1	Power Train Schematic .....	100
3.3.8-1	Center-of Gravity Loading Diagram Model LCFA-133-1 (ASW) .....	104
3.3.9-1	Pitch/Roll/Yaw Control .....	108
3.3.9-2	Flight Control Schematic .....	110
3.3.9-3	Flight Control System, Relationship of Primary Controls to Actuation Systems .....	111
3.3.9-4	Flight Control Modes .....	112
3.3.9-5	Pitch Attitude Controller .....	113
3.3.9-6	Horizontal Speed Controller .....	115
3.3.9-7	Roll Angle and Side Velocity Controller .....	116
3.3.9-8	Yaw Rate Controller .....	117
3.3.9-9	Rate of Climb Controller .....	118
3.3.9-10	Roll Control Power Capability, Model 1041-133 .....	120
3.3.9-11	V/STOL Control System Response .....	121
3.3.9-12	Hover Gyroscopic Moments, Model 1041-133 .....	123
3.3.9-13	Hover in a Crosswind (Light Gross Weight) .....	123
3.3.9-14	Thrust Vectoring Trim Schedule, Model 1041-133 .....	125
3.3.9-15	Thrust Vectoring Trim Schedule, Model 1041-133 .....	126
3.3.9-16	Static Directional Stability Cruise Vertical Fin Size .....	127
3.3.9-17	Horizontal Tail Size .....	129
4.1-1	General Arrangement, Model 1041-133 .....	132
4.1-2	Overlay Comparison .....	133
4.1.3-1	Drag Due to Lift LCFA 1041-134 (All New A/P) Mach = 0.6 .....	137
4.1.3-2	Roughness Plus Excrescence Drag Factor .....	138

## FIGURES (Concluded)

No.		Page
4.1.3-3	Drag Due to a Jet Engine Nacelle Attached to a Fuselage as a Function of Pylon Length .....	139
4.1.3-4	Drag Polar LCFA 1041-134-All New A/P .....	140
4.1.3-5	Low-Speed Drag Polar LCFA 1041-134-All New A/P .....	141
4.1.3-6	Aerodynamic Lift Power Off LCFA 1041-134 All New A/P .....	142
4.1.3-7	Power-on Lift LCFA 1041-134 .....	143
4.1.4-1	Model 1041-134 Control Response Time, G.W. 22,500 lb .....	146
4.1.6-1	Balance Diagram Net Technology Airplane .....	150
4.1.7-1	LCFA Technology Airplanes, Typical Terminal Area Test Missions .....	152
4.1.7-2	LCFA Technology Airplanes Ferry Mission Performance Rules .....	153
4.1.7-3	Takeoff Performance LCFA 1041-134, All New Airplane .....	154
4.1.7-4	Landing Performance LCFA 1041-134 All New Airplane .....	155
4.1.7-5	Level Flight Capability LCFA 1041-134 All New Airplane .....	157
4.2-1	Technology Airplane Modified T-39 (Sabreliner), Model 1041-135-2 .....	159
4.2-2	Overlay Comparison .....	160
4.2-3	Drag Polar LCFA 1041-135-2 .....	161
4.2-4	Low-Speed Drag Polar .....	162
4.2-5	Aerodynamic Lift Power Off .....	163
4.3-1	Limited Flight Envelope Technology Airplane Modified T-39 (Sabreliner), Model 1041-136 .....	166



## TABLES

No.		Page
1.0-1	Multimission Aircraft .....	6
1.0-2	T701 Engine .....	6
1.0-3	Operational and Technology Airplane Weight Comparison .....	9
3.1-1	Lift/Cruise Fan NASA/Navy V/STOL .....	30
3.1-2	LCFA Configurations-Point Design Mission Summaries .....	31
3.1-3	Point Design Weight Summary, Mission-Sized Airplanes .....	32
3.2-1	Multimission Aircraft Comparison .....	34
3.2-2	Multimission Weight Summary .....	36
3.3.3-1	Drag Summary Nonlift Dependent .....	66
3.3.3-2	Combat Load Factors W = 33,810 lb .....	82
3.3.6-1	Installed Static Performance Sea Level 90° F Day .....	95
3.3.6-2	Comparison of Current to Growth T701 Engine .....	96
3.3.8-1	Multimission Airplane, Model 1041-133-1 .....	102
3.3.8-3	Weight Increments for Special Features .....	105
3.3.8-4	ASW Inertia .....	106
4.1-1	Installed Static Performance on Technology Aircraft .....	135
4.1.3-1	LCFA 1041-134 Zero Lift Drag Breakdown .....	136
4.1.4-1	Technology Demonstration Hover Control Power, Model 1041-134 .....	145
4.1.6-1	Technology Airplane Weight Statement NASA/Navy V/STOL-Part II .....	148
4.1.6-2	Lift/Cruise Fan and Transmission System Weight, lb, Technology Airplane .....	149
4.2-1	Possible Technology Demonstrator Modification Comparison Chart .....	158
4.4-1	Weight Summary Technology Airplane .....	168

## SYMBOLS AND ABBREVIATIONS

A	aspect ratio= $b^2/S$ ; nozzle area= $ft^2$ ( $m^2$ )
A/P	airplane
ASW	antisubmarine
b	wing span= $ft^2$ ( $m^2$ )
BCAV	best cruise altitude and velocity
BPR	bypass ratio—fan airflow to primary airflow
BS	body station
$\bar{c}$	mean aerodynamic chord
c.g.	center of gravity
$C_D$	drag coefficient, $D/q_s$
$C_L$	lift coefficient, $L/q_s$
$C_{L\ max}$	maximum lift coefficient
$C_{L_x}$	lift curve slope
CSAR	combat search and rescue
D	drag, lb (N)
DDA	Detroit Diesel Allison
e	Oswald efficiency factor on drag due to lift ( $C_D = C_{D0} + CL^2/\pi Ae$ )
F	thrust, lb (N)
$F_G$	gross thrust, lb (N)
$F_{g\ max}$	maximum gross thrust, lb (N)
$F_{L/C}$	lift cruise fan thrust, lb (N)

$F_N$	net thrust, lb (N)
$F/W$	thrust-weight ratio, lb/lb (N/N)
G.E.	General Electric Company
gpm	gallons per minute
GW	gross weight
HLH	heavy lift helicopter
HP	horsepower (W)
IOC	initial operating capability
$I_x$ $I_y$ $I_z$ }	moments of inertia, slug ft <sup>2</sup> (kgm <sup>2</sup> )
kn	knot
KEAS	knots equivalent airspeed
KTAS	knots true airspeed
L	lift, lb (N)-characteristic length
LE	leading edge
M	Mach number; pitching moment ft lb (N m)
MAC	mean aerodynamic chord
MH	maximum horizontal flight Mach number
N	number of engines; yawing moment ft/lb (N/m)
OEW	operating empty weight, lb (kg)
P	pressure lb/ft <sup>2</sup> (N/m <sup>2</sup> )
$P_{Tmax}$	maximum total pressure, lb/ft <sup>2</sup> (N/m <sup>2</sup> )
$P_{Tmin}$	minimum total pressure, lb/ft <sup>2</sup> (N/m <sup>2</sup> )

q	dynamic pressure, lb/ft <sup>2</sup> (N/m <sup>2</sup> )
R <sub>C</sub>	compressor pressure ratio
R <sub>F</sub>	fan pressure ratio
S	wing or reference area, ft <sup>2</sup> (m <sup>2</sup> )
SA	surface attack
SAS	stability augmentation system
SFC	specific fuel consumption, lb/hr/lb (kg/s/N)
STOL	short takeoff and landing
T	temperature, deg
TAS	true airspeed
tc	thickness/chord ratio
TIT	turbine inlet temperature, deg
T.O.	takeoff
TOGW	takeoff gross weight, lb (kg)
V	velocity, kn (m/s)
V <sub>H</sub>	level flight maximum speed
VL	vertical landing
V <sub>0</sub>	freestream velocity
VOD	vertical onboard delivery
V/STOL	vertical/short takeoff and landing
VTO	vertical takeoff
VTOGW	vertical takeoff gross weight, lb (kg)
VTOL	vertical takeoff and landing
W	weight, lb (kg); airflow, lb/s (kg/s); watts

WBL	wing body line
$W_F$	fuel flow, lb/hr (kg/hr)
Greek:	
$\alpha$	angle of attack, deg (rad)
$\gamma$	flightpath angle, deg (rad)
$\delta$	pressure ratio $P/P_{SL, std}$ ; flap deflection, deg (rad)
$\theta$	pitch angle, deg (rad); temperature ratio, $\frac{T}{T_{SL, std}}$
$\lambda$	gross thrust vector angle relative to the horizontal body reference line: when thrust is horizontal and forward, $\lambda = 0^\circ$ ; when thrust is vertical and up, $\lambda = 90$ deg (rad)
$\Lambda_c/4$	sweep of the quarter chord line, deg (rad)
$\phi$	roll angle, deg (rad)
$\psi$	yaw angle, deg (rad)

## 1.0 SUMMARY

Hub driven, variable pitch fans connected to turboshaft engines through a mechanical transmission offer the airplane designer a flexible means for selecting a good compromise between the requirements for high thrust at low speed and efficient thrust at cruise speed. This compromise is extremely important in selecting the propulsion arrangement for high speed, vertical takeoff airplanes. The present study was performed to examine the applicability of such a propulsion system to V/STOL aircraft intended for Naval sea control operations.

The study was accomplished in two parts. Part I consists of a series of naval operational aircraft designs leading to a multi-purpose airplane capable of performing a variety of missions with minimum modification.

In Part II a family of technology demonstrator aircraft was designed, each of which could represent to various degrees the technical features of the multi-mission airplane.

The relationship of the 13 resulting configurations and their identifying model numbers are shown on Figure 1.0-1.

### OPERATIONAL AIRPLANES

As a result of the point design configurations studied in Part I, the ASW airplane became the basis for the multi-mission design.

An isometric view, emphasizing the V/STOL features, is shown in Figure 1.0-2. The two engines are mounted behind the variable pitch lift/cruise fans, and the engine/fan units rotate to provide thrust vectoring for V/STOL operation. A variable pitch lift-fan is mounted ahead of the crew stations and is driven by interconnecting shafts.

In cruise and high speed flight the airplane is conventional in appearance and operation. The nose fan is disengaged at the cross shaft.

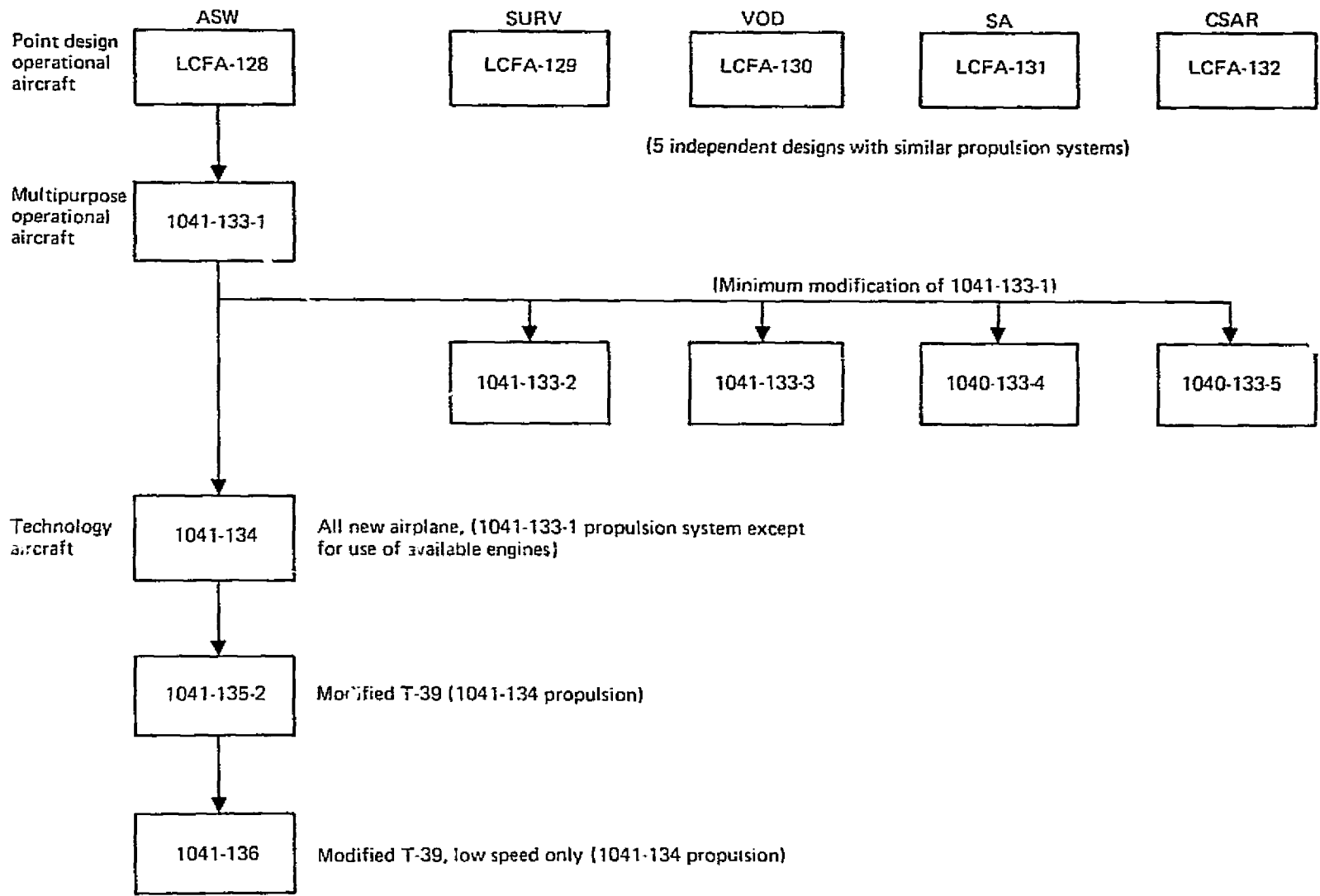

Figure 1.0-1.—Hierarchy of Designs

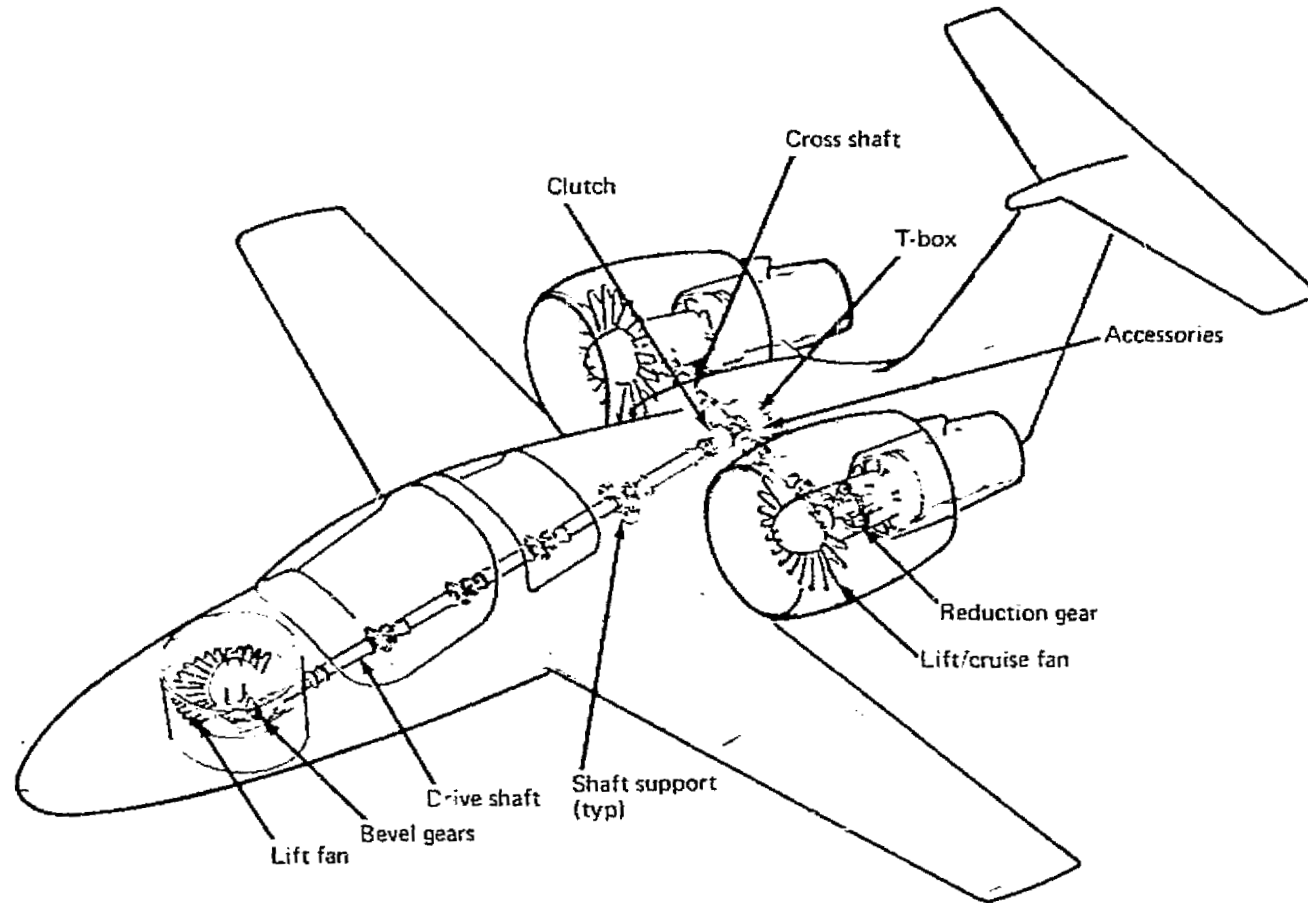

Figure 1.0-2.-1041-133 VISTOL Aircraft



A summary of the point designs developed in the Part I study are shown in Figure 1.0-3. The VOD is an exception to this family in that it requires three engines rather than two and its fuselage is substantially different due to the transport mission requirement. Otherwise, the ASW design is critical; that is, the ASW airplane must be somewhat larger than the other point designs and it can be readily modified to perform the other missions in its multimission role.

Therefore, Model 1041-133-1 is presented as the typical operational airplane. The arrangement is the natural result of the basic assumptions on propulsion failure: (1) safe flight is possible after engine failure including safe failure transients during specific flight conditions and (2) there is no provision for fan failure during V/STOL maneuvers. The second assumption is similar to helicopter design philosophy with regard to rotor failure.

Model 1041-133-1 is designed by flying the ASW mission from a short takeoff carrying a 2820 lb. payload 150 nautical miles, loiter 4 hours, return 150 miles with reserves and land vertically. With the addition of water/alcohol the airplane can fly the same mission from vertical takeoff and loiter 3.16 hours at 150 mile radius.

The basic configuration for all the missions is similar (with the exception of VOD which requires an extra engine). The resulting configurations have three fans, two for lift/cruise and one for lift only. The three fans are identical. The two engines are developments of the Detroit Diesel Allison T701 or equivalent and the three fans are developments of the Hamilton-Standard "Q-Fan" variable pitch fans. The multi-mission airplane weights for the various missions are listed in Table 1.0-1.

The static performance of the propulsion combination used for both the operational and technology airplanes at sea level and 90°F is shown on Table 1.0-2. Each engine drives a reduction gear set through an overrunning clutch. A right angle bevel set distributes power to the front fan through a "T" box and clutch. Airplane accessory power is taken from the rear of the "T" box. The clutch adjacent to the "T" box disconnects the front fan during conventional flight.

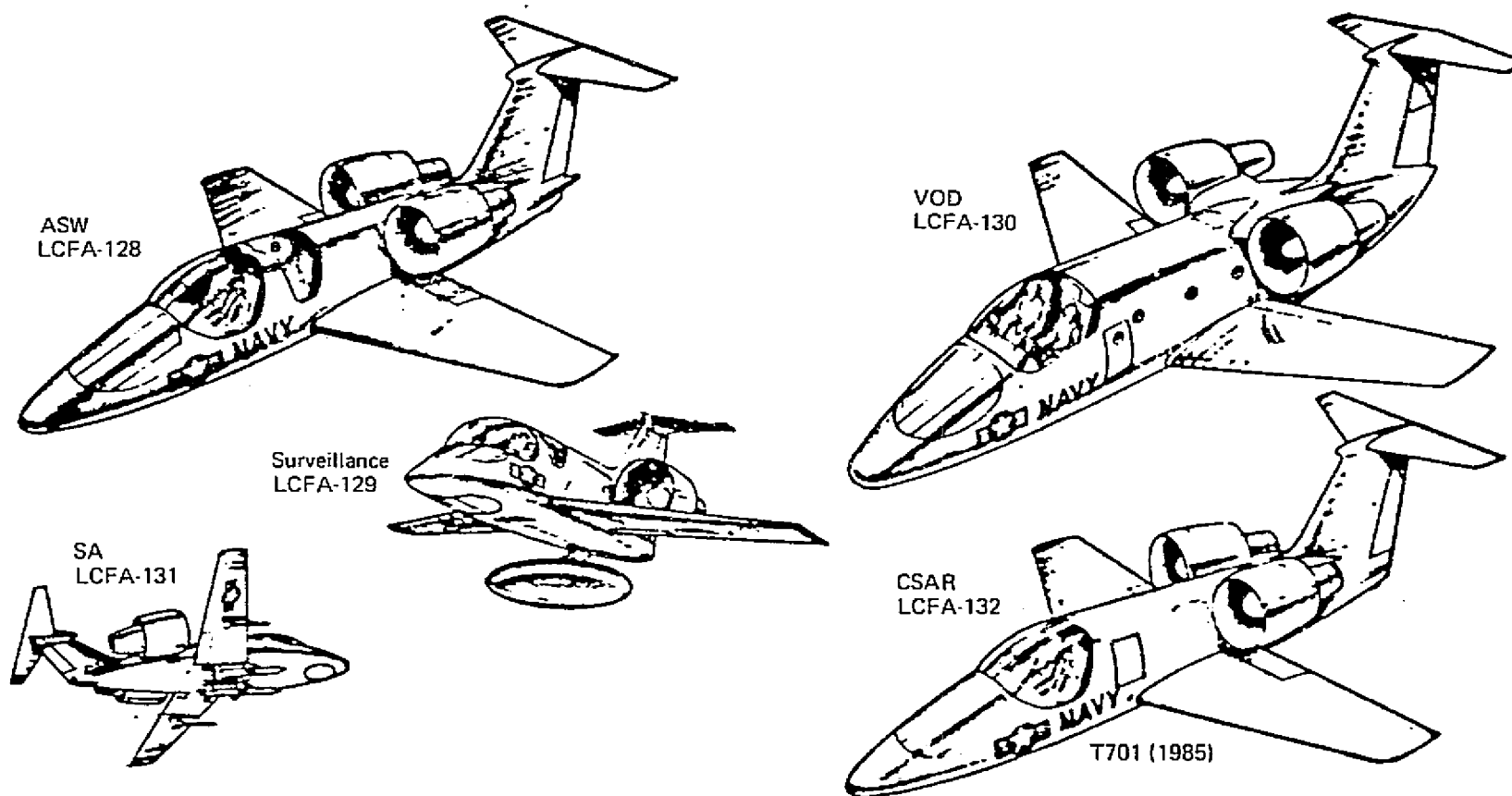

	ASW -128	Surv -129	VOD -130	SA -131	CSAR -132
Number of engines	2	2	3*	2	2
Wing area, ft <sup>2</sup>	310	265	350	250	270
Emergency landing weight required	24 500	24 420	30 300	20 180	23 090
Emergency landing weight capability	24 500	24 500	30 300	24 500	24 500
Mission GW	37 750	32 220	42 300	30 350	31 730

\*T701 (current).

Figure 1.0-3.—Point Designs

Table 1.0-1.-Multimission Aircraft

	ASW 1041-133-1	SURV 1041-133-2	VOD 1041-133-3	SA 1041-133-4	CSAR 1041-133-5
Number of engines	2	2	3	2	2
Mission GW, lb	37 750	32 650	42 530	30 810	30 850
Emergency landing weight, lb	24 500	25 000	30 440	21 280	23 000
Emergency landing weight capability, lb	25 000	25 000	38 000	25 000	25 000

Table 1.0-2.-T701 Engine\*

	Intermediate power, two engines, three fans		Contingency power, one engine, three fans	
	Fan pressure ratio	Total fan thrust, lb	Fan pressure ratio	Total fan thrust, lb
Current (1975)	1.14	27 680	1.12 <sup>†</sup>	21 000 <sup>†</sup>
1985	1.17	34 000	1.13	25 330

\*Sea level, 90° F, day

<sup>†</sup>Water/alcohol augmentation

Thrust vector control during V/STOL operation is achieved by rotating the lift/cruise fan nacelles. The nose fan thrust vector is fixed  $15^{\circ}$  forward of vertical. During V/STOL transition, as the nacelles rotate and their moment arm about the c.g. changes, the nose fan thrust level is changed to balance the moments.

A very important design constraint is the requirement for one engine out operation during low speed flight and hover. The operational airplane was designed to have engine out capability at emergency weight (weapons stores and all but 1,000 lbs. of fuel jettisoned) with the remaining engine at contingency power.

#### TECHNOLOGY AIRPLANES

The technology airplanes of the Part II study were based on the ASW version of the multi-purpose design. The propulsion arrangement and size is the same as the ASW except for the engines which are current models of the operational engine. The static thrust available is shown on Table 1.0-2. Water-alcohol injection is used to provide contingency power in the event of single engine operation.

A three view of the all new technology airplane, Model 1041-134, is shown on Figure 1.0-4. Compared to the multimission airplane, it has a more slender fuselage, a two place instead of a four place cab and a smaller wing. The wing size was reduced to maintain the operational wing loading for similarity in flight characteristics. These differences result in an operating weight of 16,400 pounds compared to 23,500 pounds for the operational ASW. A comparison of pertinent weight is shown on Table 1.0-3.

With full payload and 2 crew members, at emergency landing gross weight of 20,400 lbs; it carries 1,490 pounds of fuel. This will provide a hover endurance of 18 minutes. The all engine operating thrust/weight ratio is 1.36 at this weight. Vertical flight at higher weight is safe within a limited hovering envelope.

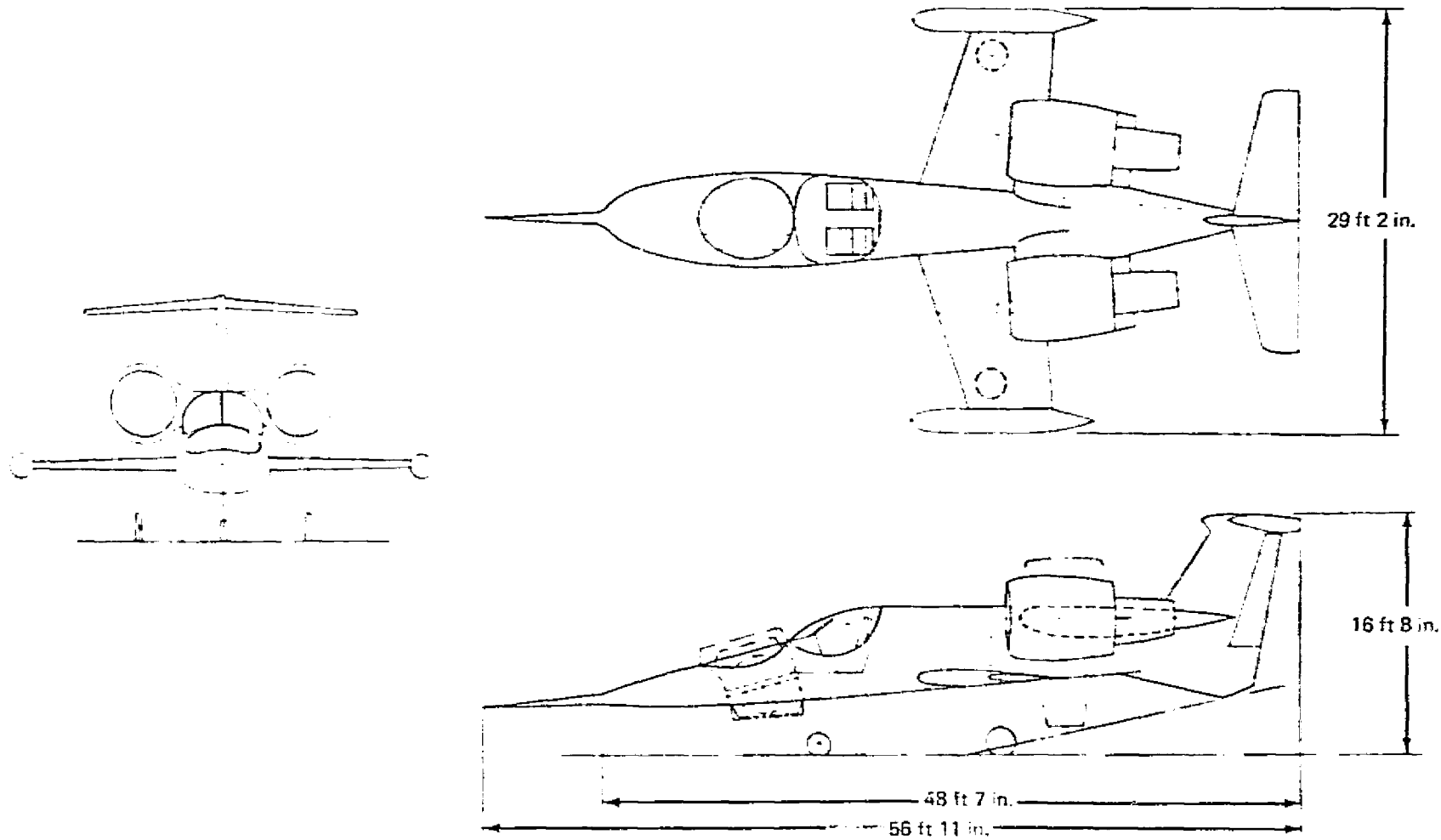

Figure 1.0-4.-All New Technology Airplane, Model 1041-134

Table 1.0-3.—Operational and Technology Airplane Weight Comparison

	Operational airplane 1041-133, lb	Technology airplane 1041-134, lb	ΔWeight, lb
Structure	7 920	6 290	-1 630
Propulsion	7 480	6 910	-570
Equipment	6 500	2 600	-3 900
Empty weight	21 900	15 800	-6 100
Nonexpendable useful load	1 600	600	-1 000
Operating weight	23 500	16 400	-7 100
Payload	2 820	2 500	-320
Fuel	12 070*	1 540†	
Gross weight (ASW mission)	37 750	—	
Emergency landing weight	24 500	20 400	-4 100

\* Includes external tanks.

† Includes H<sub>2</sub>O/alcohol.

A technology airplane based on modifying a Rockwell International T-39 Sabreliner was studied as a means of reducing cost (Model 1041-135-2). A general arrangement is shown on Figure 1.0-5. Modification consists primarily of removing unnecessary weight, changing the nose and aft body to accept the V/STOL propulsion system, and replacing the canopy to permit ejections. Its operating weight is 700 pounds heavier than the all new 1041-134. At the single engine emergency weight, it can carry 790 pounds of fuel with 2 crew members and full payload. A hovering endurance of 9 minutes can be extended by removing part of the payload or limiting the hovering envelope. The major disadvantage of this concept is the unnecessarily large wing of the T-39. The cost of reducing the wing size on the -135-2 would cancel the cost saving due to modification.

A further small cost reduction was achieved by limiting the operation of a modified airplane to the low speeds associated with takeoff, landing and transition. This configuration, Model 1041-136, is also a modification of the T-39. Additional changes consist mainly of removing the canopy, fixing the landing gear and removing unnecessary doors and actuators. This airplane is 600 pounds lighter than the -135-2 and only 100 pounds heavier than the all new -134.

These three technology airplanes offer a classic cost/weight/performance trade:

- The all new -134 costs the most, has low risk on weight and has good performance.
- The modified T-39 is less expensive, has a low weight margin, and has good performance.
- The low speed modified T-39 is the least expensive, it has low risk on weight, but its performance capability is limited to low speed.

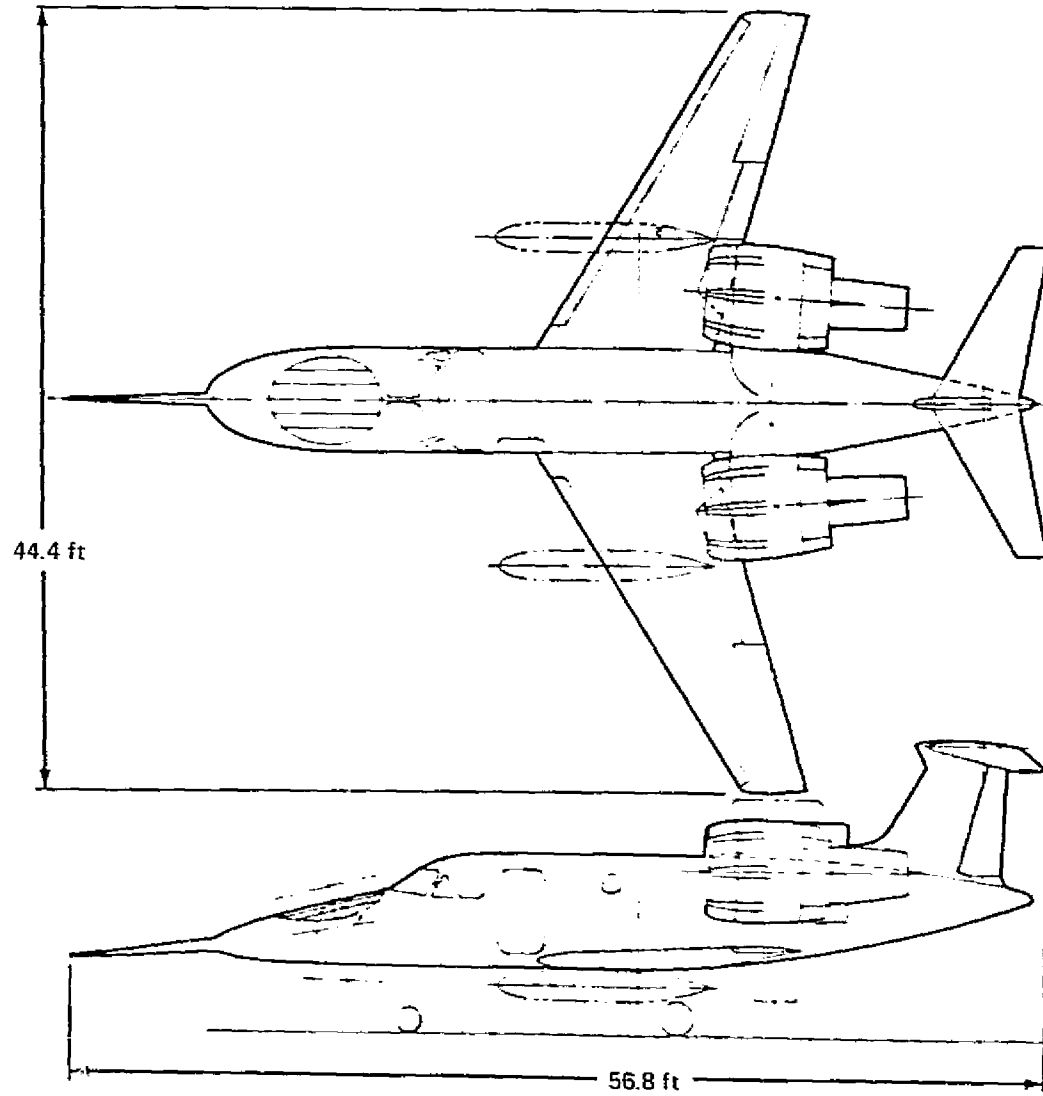

Figure 1.0-5.—Modified T-39 Technology Airplane, Model 1041-135-2



## 2.0 INTRODUCTION

Many successful V/STOL experimental aircraft have flown in the last two decades. Few except for helicopters, have resulted in useful operational systems. Recent trends in the strategy of naval warfare have revealed a potential requirement for high speed V/STOL airplanes that may well supply the mission requirement for vertical takeoff that has been missing in previous studies and experiments. This turn of events could result in the introduction of high speed V/STOL airplanes as a major element in the composition of modern naval forces.

Successful development of vertical and short takeoff and landing aircraft with good payload-range and high speed capability will allow effective air power to be dispersed throughout the fleet instead of being concentrated on conventional aircraft carriers.

Other military applications are evident. Troop deployment, rescue, surveillance and attack missions of both the Army and Marines could profit from the development of high speed, VTO aircraft.

In the civil applications development and re-supply at remote locations in difficult environment can also be improved by high productivity VTO aircraft.

This study has addressed the problem of designing a vertical takeoff airplane to perform the naval mission. It is shown that proper selection of modern propulsion components combined with a traditional aerodynamic configuration can yield a twin engine airplane having very respectable conventional performance together with excellent vertical takeoff capability and engine out safety. Performance and control after engine failure is superior to that of conventional twins during normal flight. Conventional safety margins are retained during very low speed flight and hover.

The selection of a lift/cruise fan system at a disk loading balanced between the requirements for low speed thrust and high speed fuel economy has resulted in an airplane which minimizes the inherent penalty of vertical takeoff. Figure 2.0-1 shows the application of these principles to a V/STOL ASW airplane and compares it to the performance of the conventional, carrier based S-3A when both are flying the ASW mission.

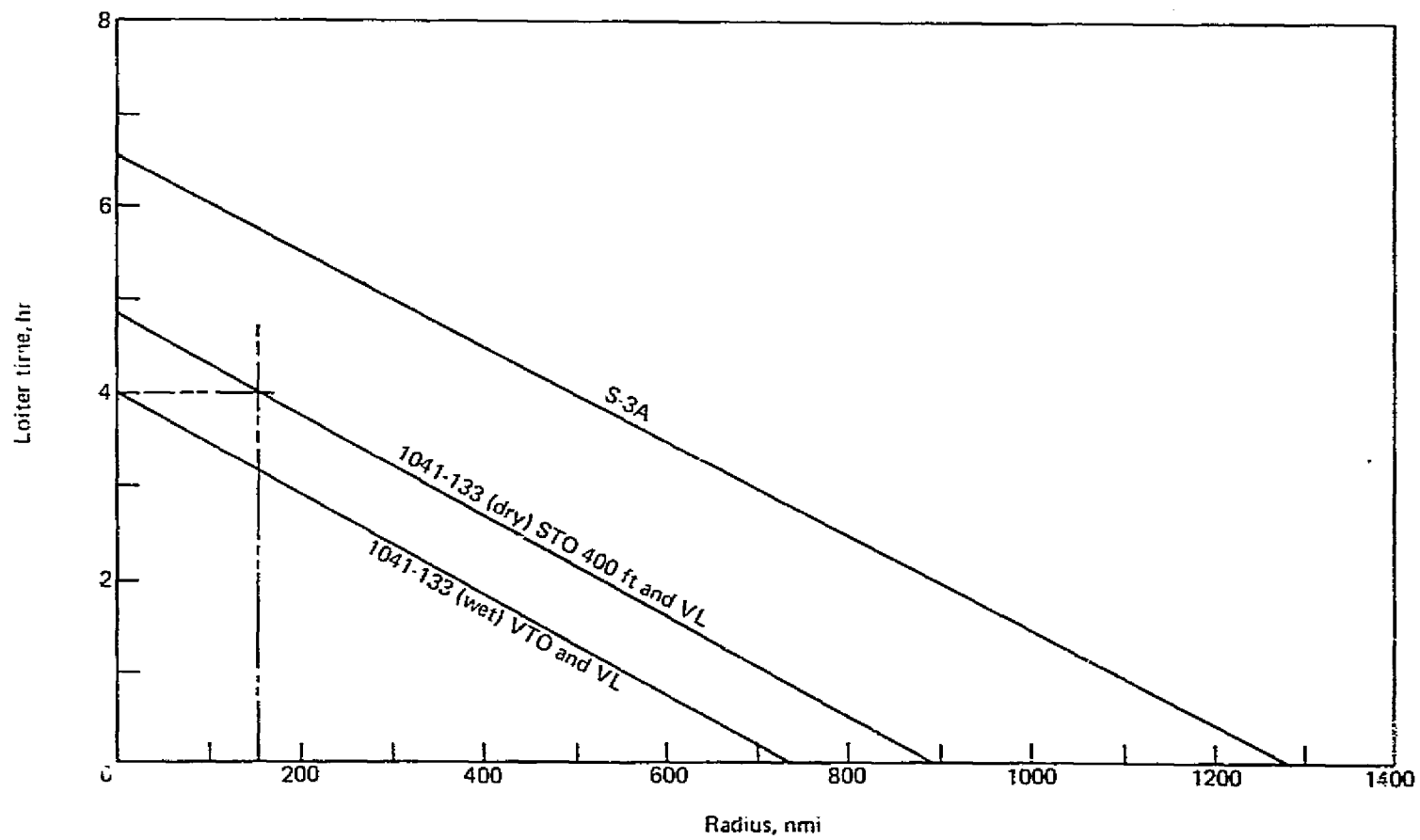

Figure 2.0-1.--ASW Mission Performance

Although the resulting design is unique principally in its combination of previously successful components, the combination does require validation. Technical risks can be resolved by demonstrating the aerodynamic, propulsion and flight control characteristics of the airplane in a technology demonstrator. Several possibilities of technology demonstrator airplanes are presented. They all share in common the advantages of being sized to an existing engine. The fan and transmission are practically identical to their full scale operational counterparts thereby demonstrating the new features at full scale but avoiding the requirement for engine development at the demonstrator stage.

### 3.0 PART I - NAVY OPERATIONAL AIRCRAFT

As part of the NAVY's control of the sea, five V/STOL aircraft missions were formulated. These ranged from aerial surveillance to transport operation. Specifically, the missions are:

- A. Surface Attack (SA) - sea control mission. Patrol for 2 hours at 20,000 feet at a radius of 300 n.mi. armed with 2 harpoons and 2 AIM-9 missiles.
- B. Antisubmarine (ASW) - Patrol at 10,000 feet for 4 hours at a radius of 150 n.mi. armed with 2 MK-46 torpedoes and 50 sonobuoys.
- C. Vertical Onboard Delivery (VOD) - Deliver 5000 lbs. of payload 2000 n.mi.
- D. Surveillance - Patrol at 25,000 feet for 4 hours at a radius of 75 n.mi. carrying surveillance avionics.
- E. Combat (strike) Search and Rescue (CSAR) - Accompany strike aircraft and perform the search and rescue as required.

Complete mission ground rules are given in Appendix A.

V/STOL Aircraft were designed for each mission. The point designs were then compared to find the best multimission airplane and to determine the mission compromises such a concept would entail.

### 3.1 Point Design Aircraft

The point design aircraft were configured to perform the five missions. A development of an existing engine (Detroit Diesel Allison T701) and 62 inch diameter variable pitch fans were used on all airplanes. They all had three fans (one lift/fan and two lift/cruise fans), and all but the VOD used two engines. The VOD needed three.

The Point Design configurations and the drag polars for each are shown on Figures 3.1-1 to 3.1-12. A comparison of these configurations is shown in Figure 1.0-3. Mission and weight summaries of these airplanes are shown on Tables 3.1-2 and 3.1-3.

The Static thrust available (at this point in the study) at sea level on a 90°F day was:

2 Engines/3 Fans; Thrust = 34,000 lbs.

1 Engine/3 Fans; Contingency Rating Thrust = 24,500 lbs.

The installed cruise performance used in calculating the performance of these designs is presented in Appendix B. Performance, other than static, is based on parametric data from Hamilton-Standard. The Hamilton-Standard estimate of installation losses is optimistic. This balances the very conservative core performance used. The installed data shown on Figures B-1 to B-10 were used as installed performance with fuel flow increased 5% to account for service tolerance included.

The total installed power required is dominated by the short takeoff and vertical landing requirements. There are three low speed conditions which can define the total thrust required. These are: (1) short takeoff, thrust weight ratio (F/W) less than one; (2) mission end vertical landing, F/W = 1.05; and (3) emergency weight, (engine out) vertical landing, F/W = 1.0. In all cases, the engine out vertical landing is critical. The emergency weight is the weight that can be attained after jettison of releasable payload. This condition can be satisfied with one or two engines for all the missions except VOD. The VOD emergency weight is high because of the large fuselage and non-releasable character of the payload.

The antisubmarine design, conceptually similar to the SA, is shown on Figure 3.1-3. It has a  $310 \text{ ft}^2$  of wing. Performs the mission from a GW of 37,750 lbs. with a short takeoff ground roll less than 400 feet in a 10K wind. The emergency weight is equal to the emergency thrust. This condition was the criterion for the selection of the fan diameter. Its drag polar is in Figure 3.1-4.

The three engine VOD is an anomaly in that the emergency gross weight must be achieved with full payload. The third engine, for use only during takeoff and landing, is beneath the floor of the cockpit, Figure 3.1-5. The shaft routing is also different from the other aircraft. A schematic is shown in Figure 3.1-6. The "T" box is located asymmetrically; from the "T" box the shaft descends along the cabin wall below the floor. An extra gearbox is used to turn the shaft forward, under the floor, to the front fan. The effect on the cabin arrangement is shown in Figure 3.1-7. The trimmed drag polar is shown in Figure 3.1-8.

The surveillance airplane features a retractable radar under the fuselage (Figure 3.1-9). A 12 ft. diameter system was used. The airplane has  $265 \text{ ft}^2$  of wing; performs the mission from takeoff gross weight of 32,220 lbs. which is a  $F/W = 1.05$ . This is sufficient for a vertical takeoff. The drag polar is in Figure 3.1-10.

The CSAR version is shown in Figure 3.1-11. Its polar is in Figure 3.1-12. The cabin, for rescue operations, is encumbered with a shaft bulge, like current automobiles. It performs the mission from a vertical takeoff with  $F/W = 1.07$ . It has a wing area of  $270 \text{ ft}^2$ .

The five point designs are compared on Tables 3.1-2 and 3.1-3. It is apparent that the ASW mission is the most stringent for the two engine airplanes. All the other missions are performed from a vertical takeoff; only the ASW needs a short ground run. On this basis the ASW configuration was used at the basis for the multimission airplane.

Wing area 310 ft<sup>2</sup>  
 Emergency weight 24 500 lb  
 Mission GW 37 750 lb

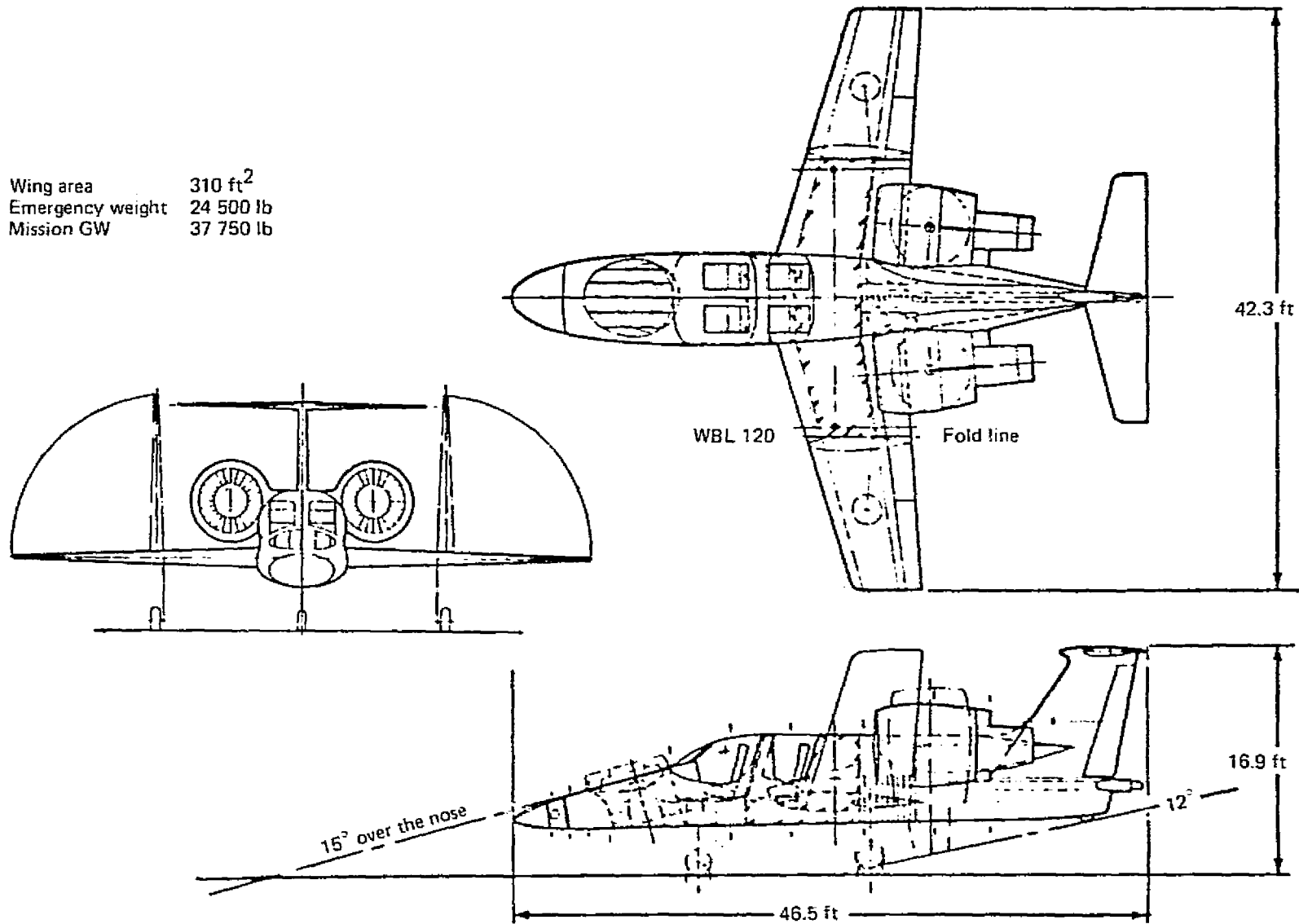

Figure 3.1-1.—Point Design, Three Fan Two Engine ASW Airplane, LCFA-128

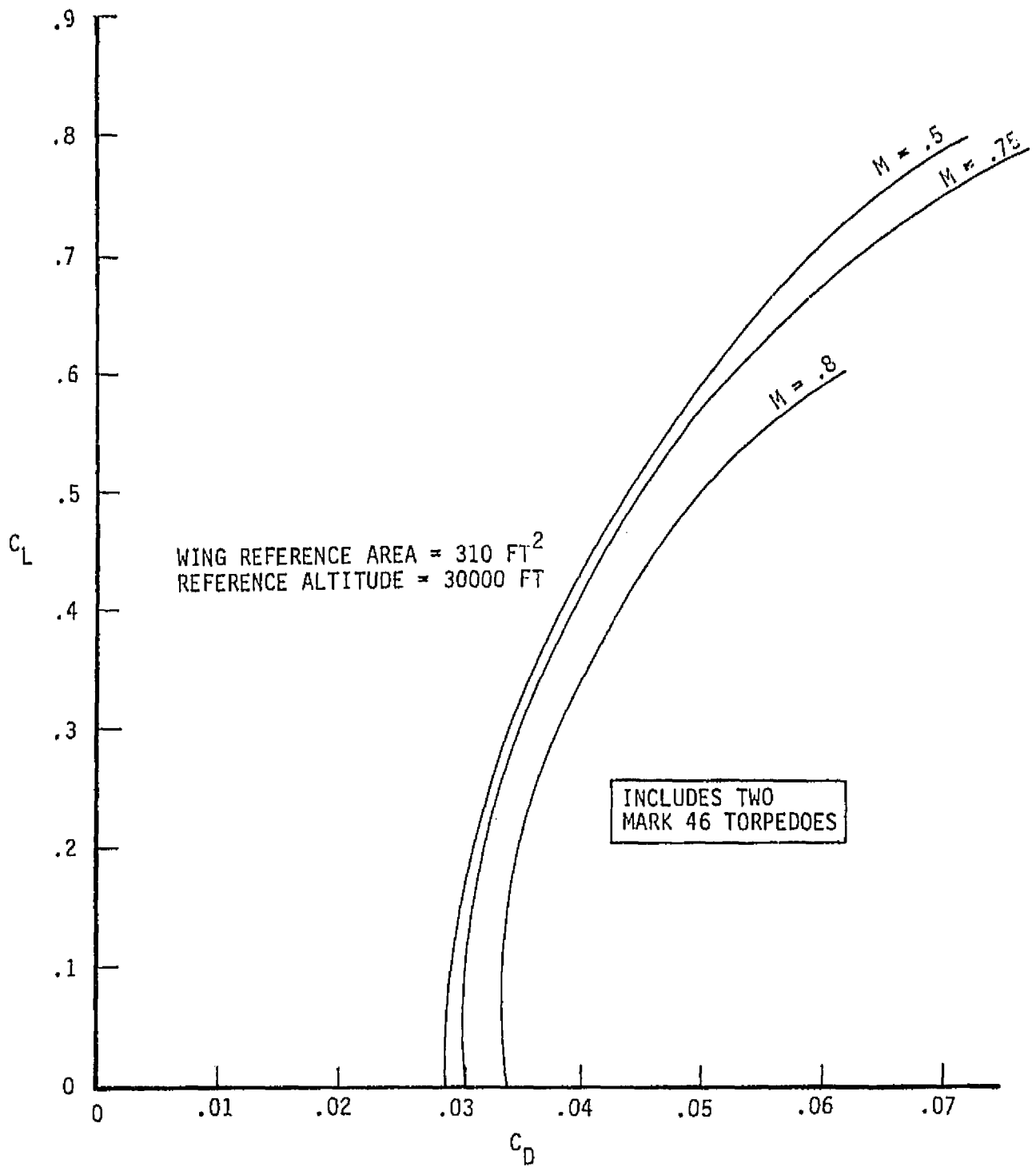

Figure 3.1-2.—Trimmed Drag Polar LCFA 1041-128 (ASW)



Wing area 265 ft<sup>2</sup>  
 Emergency weight 24 420 lb  
 Mission GW 32 220 lb

20

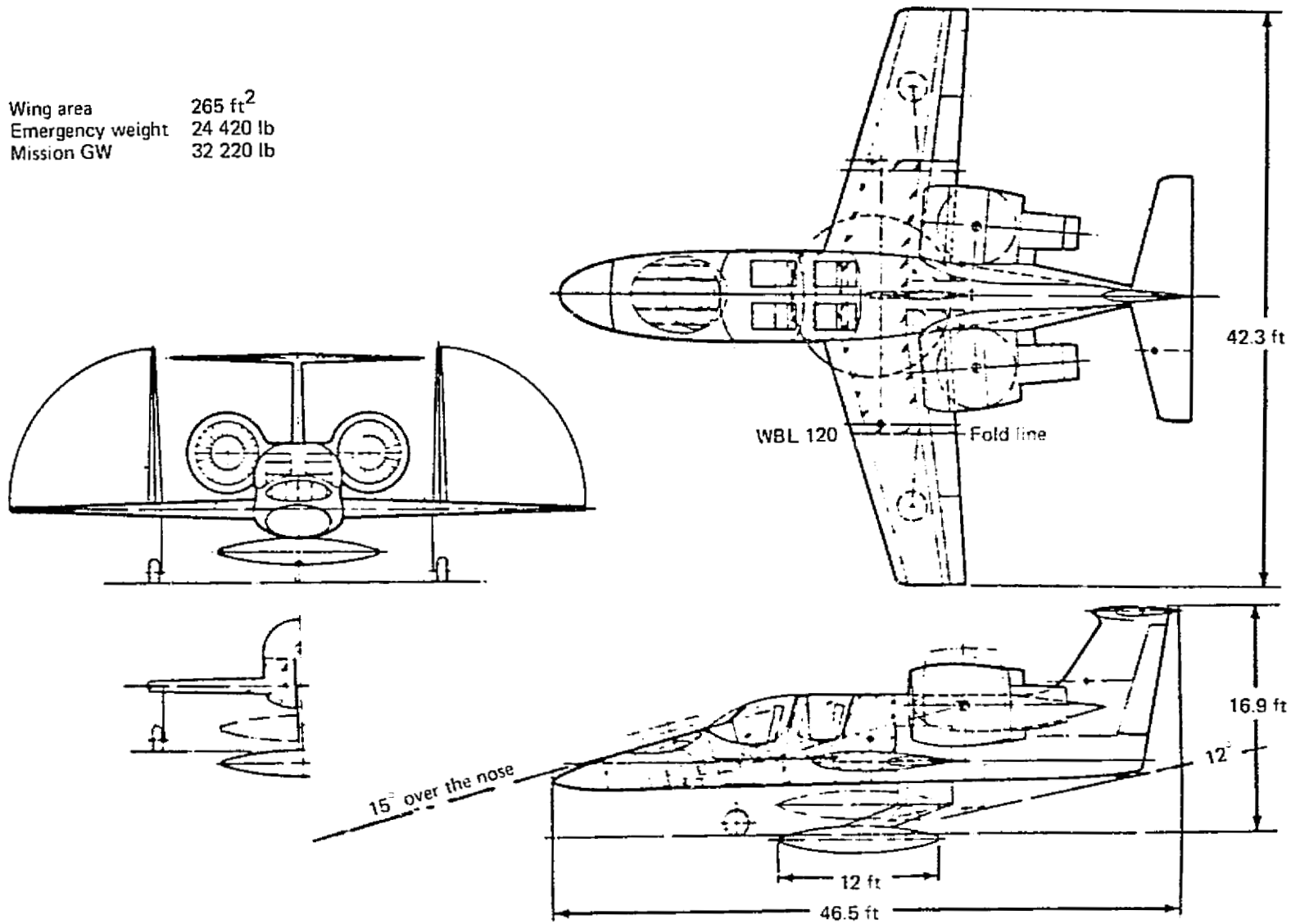

Figure 3.1-3.—Surveillance Airplane, LCFA-129

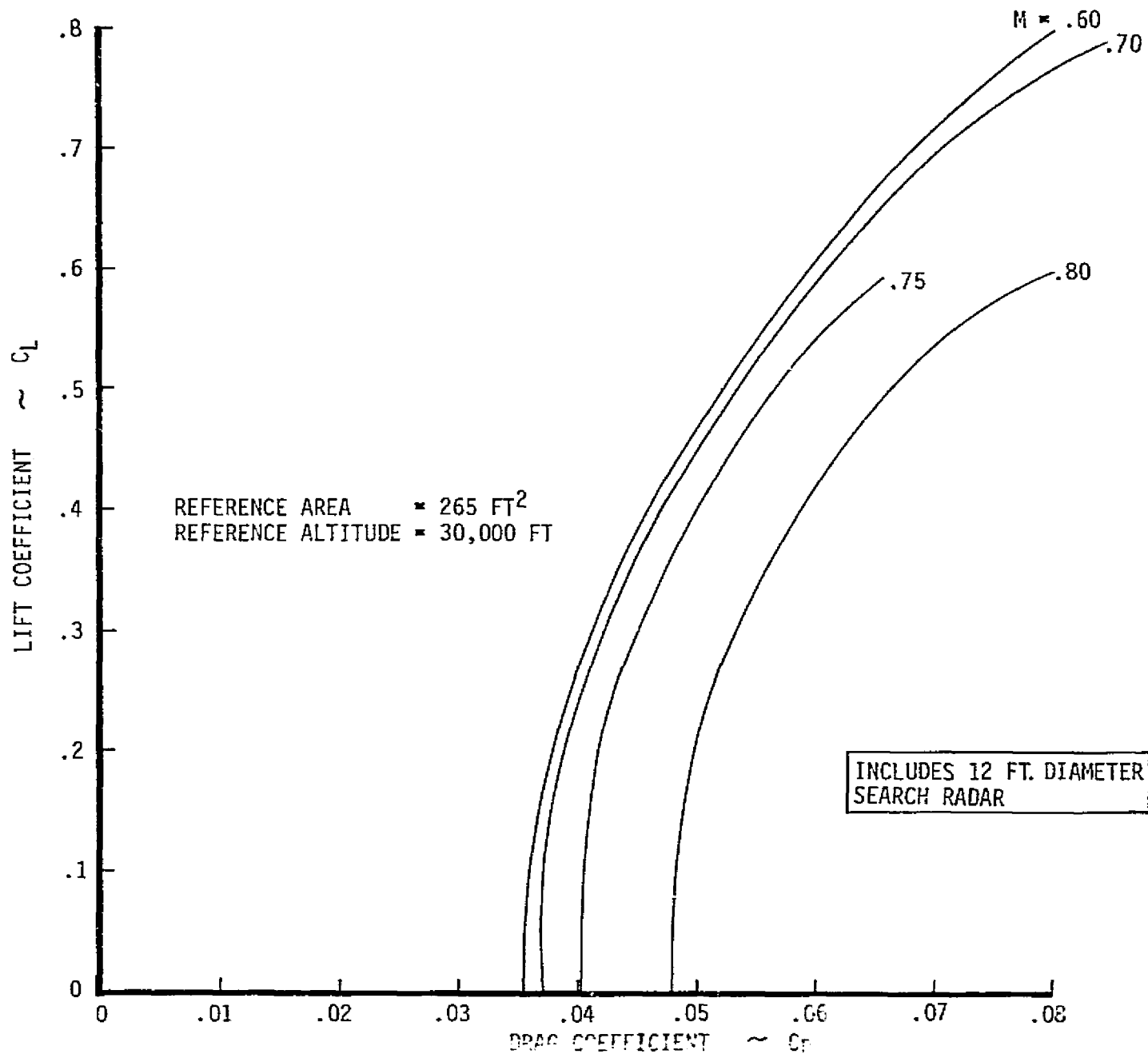

Figure 3.1-4.—Trimmed Drag Polar LCFA 1041-129 (Surveillance)

Wing area        350 ft<sup>2</sup>  
 Emergency weight 30 300 lb  
 Mission GW       42 300 lb

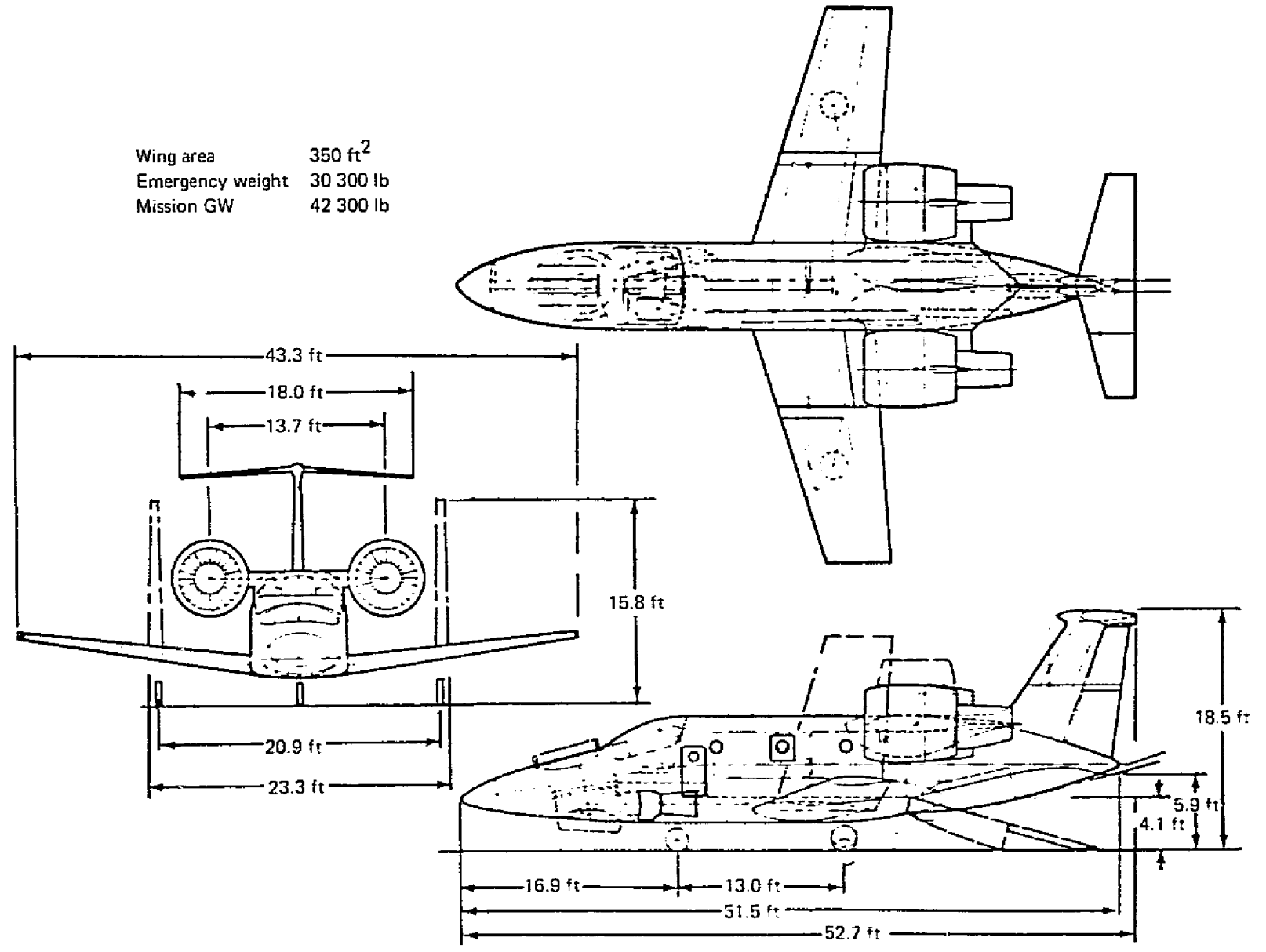

Figure 3.1-5.-VOD Airplane, Three Engines, LCFA-130

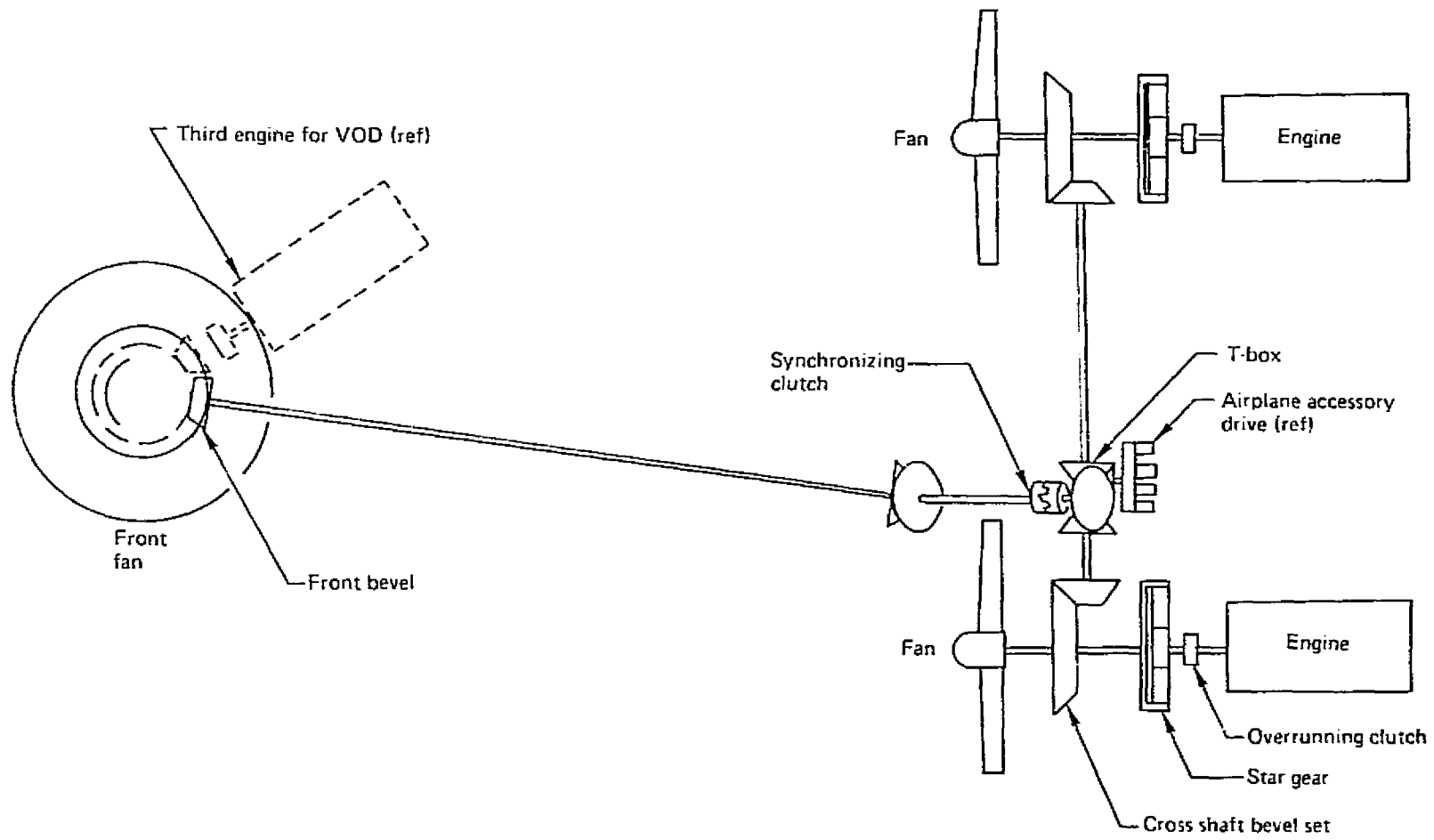

Figure 3.1-6.--VOD Three Engine Transmission

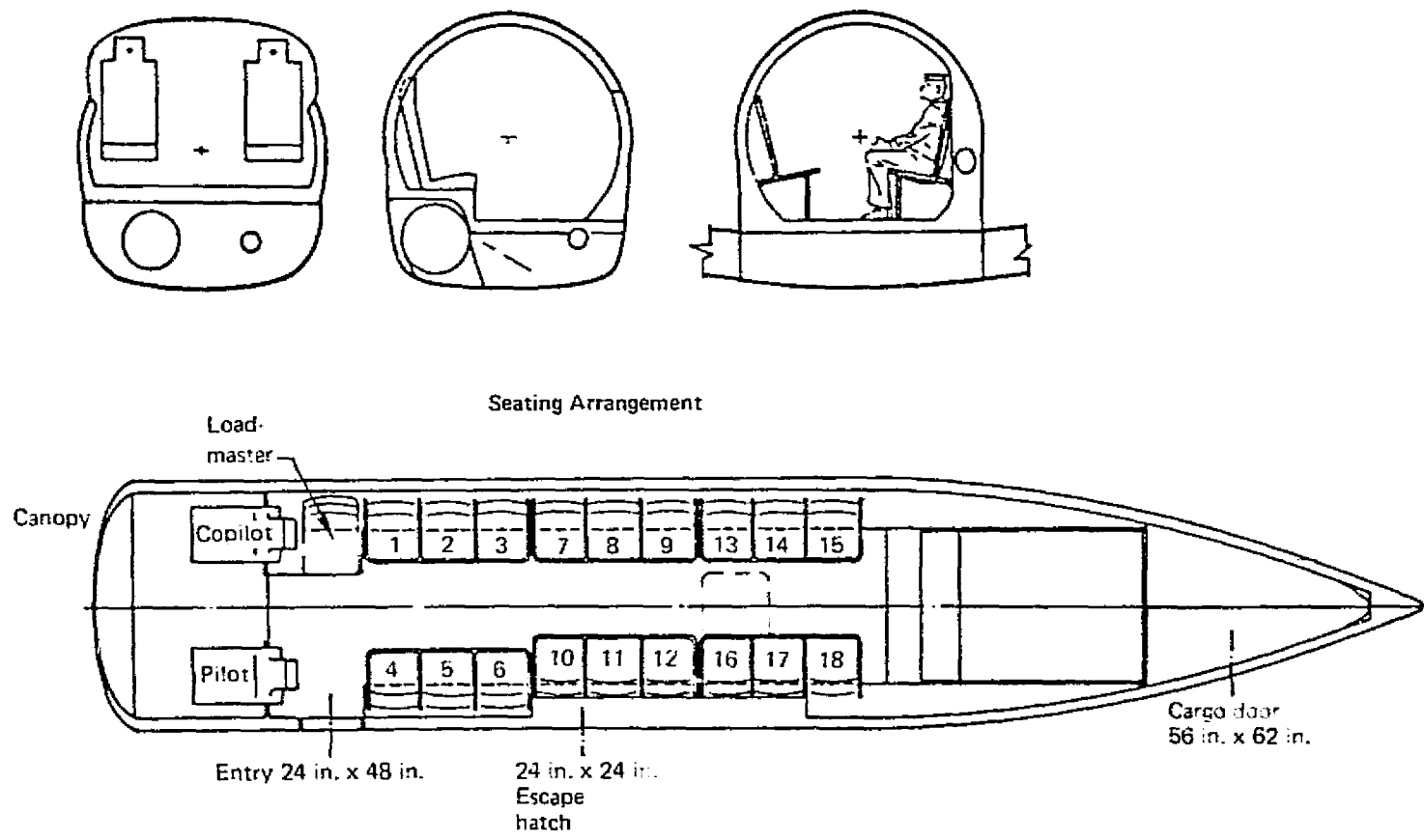

Figure 3.1-7.-VOD Airplane, Cabin Arrangement

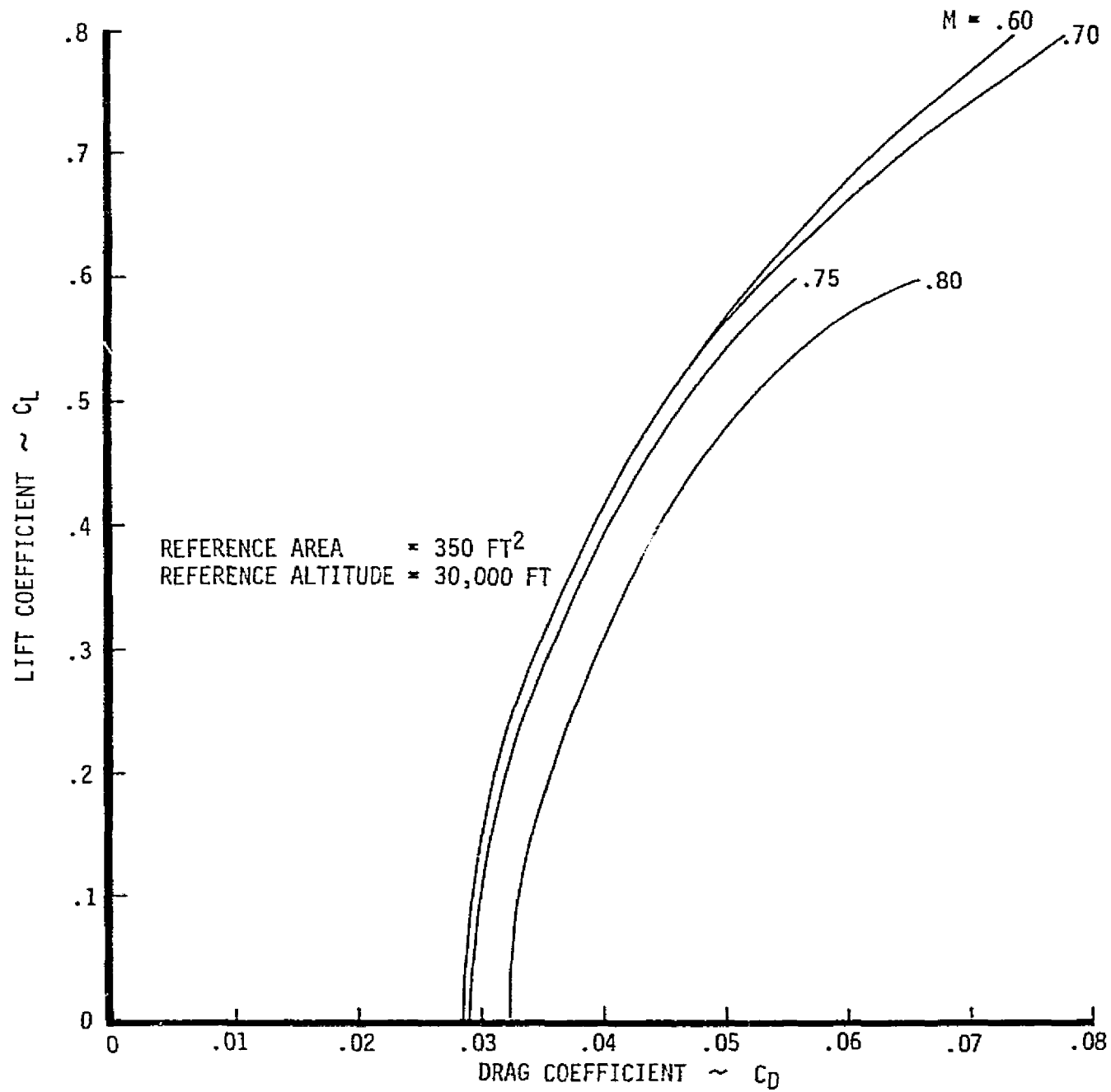

Figure 3.1-8.--Trimmed Drag Polar LCFA 1041-130 (VOD)

Wing area 250 : :<sup>2</sup>  
 Emergency weight 20 180 lb  
 Mission GW 30 350 lb  
 Mission T.O. - F/W = 1.12

26

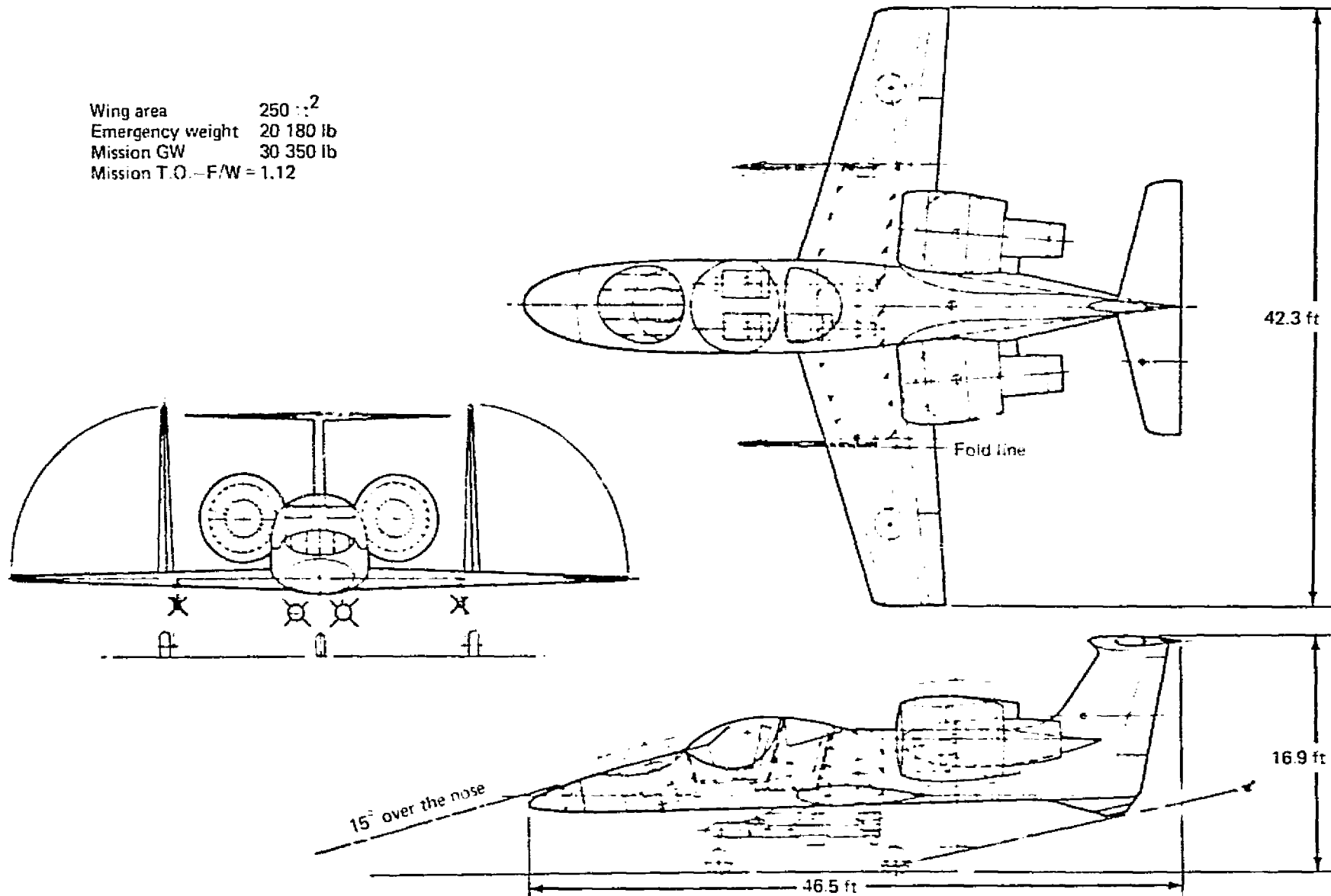

Figure 3.1-9.-Surface Attack Airplane, LCFA-131

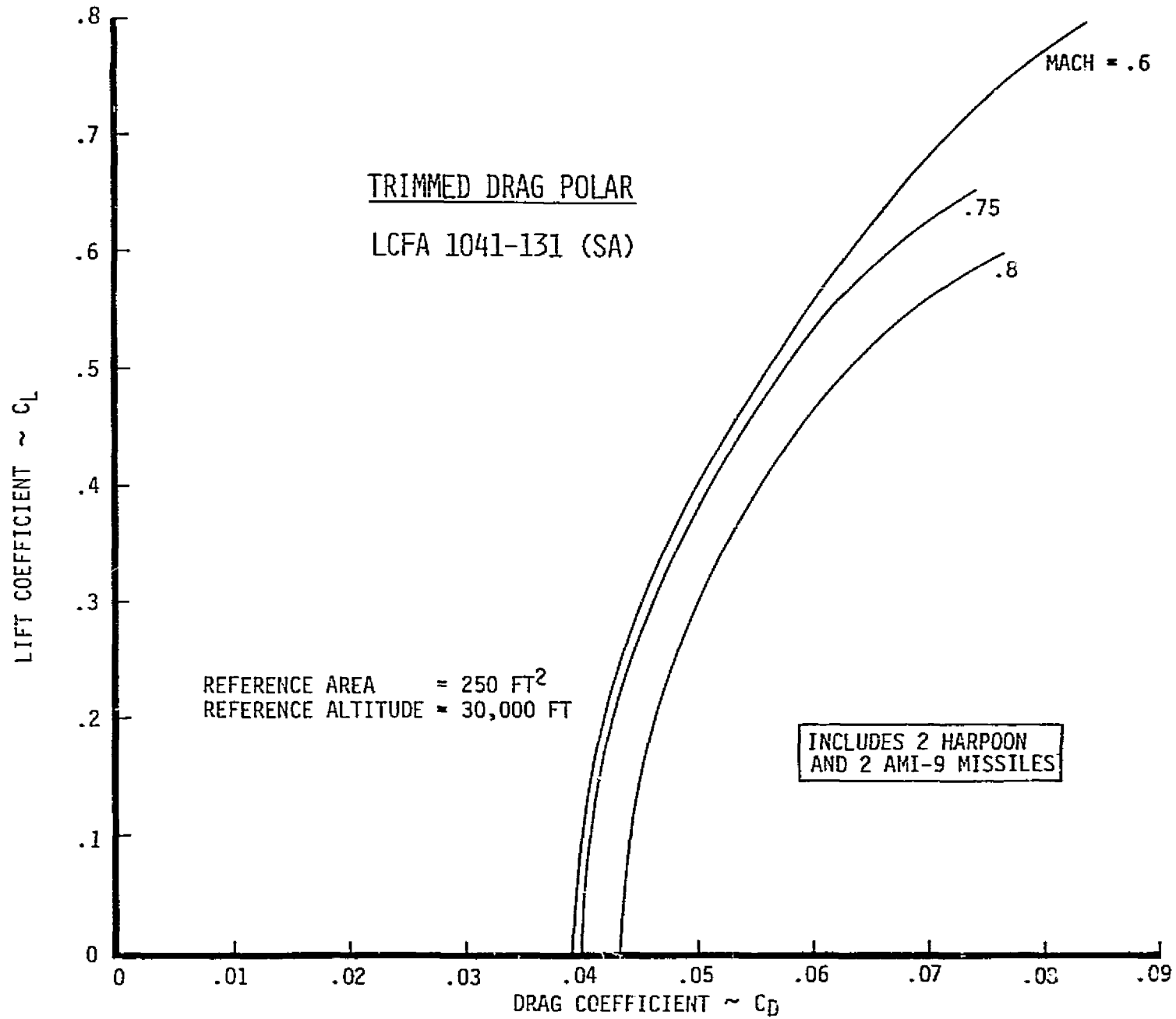

Figure 3.1-10 -Trimmed Drag Polar LCFA 1041-131 (SA)



Wing area 270 ft<sup>2</sup>  
Emergency weight 23 090 lb  
Mission GW 31 730 lb

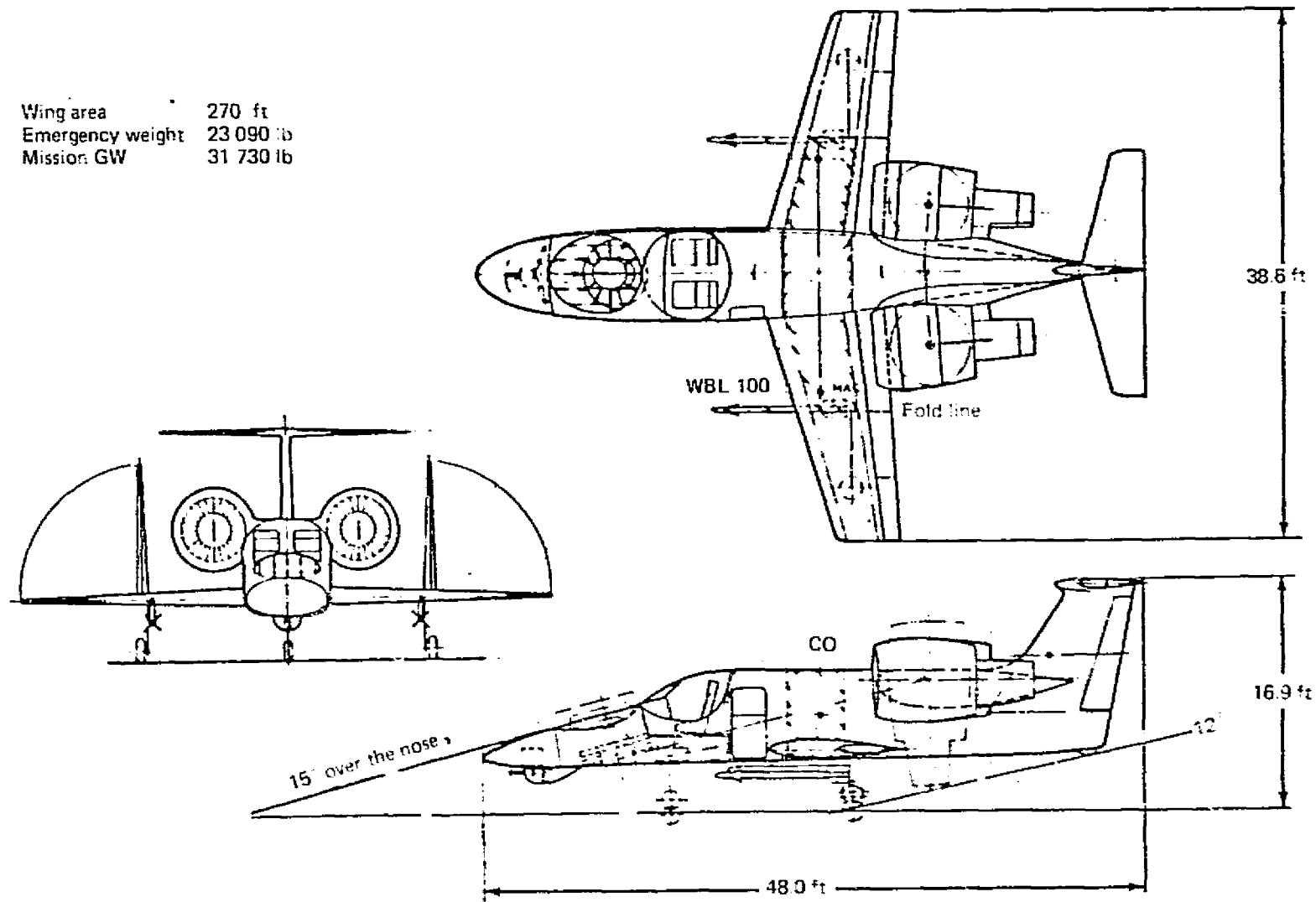

Figure 3.1-11.-CSAR, LCFA-132

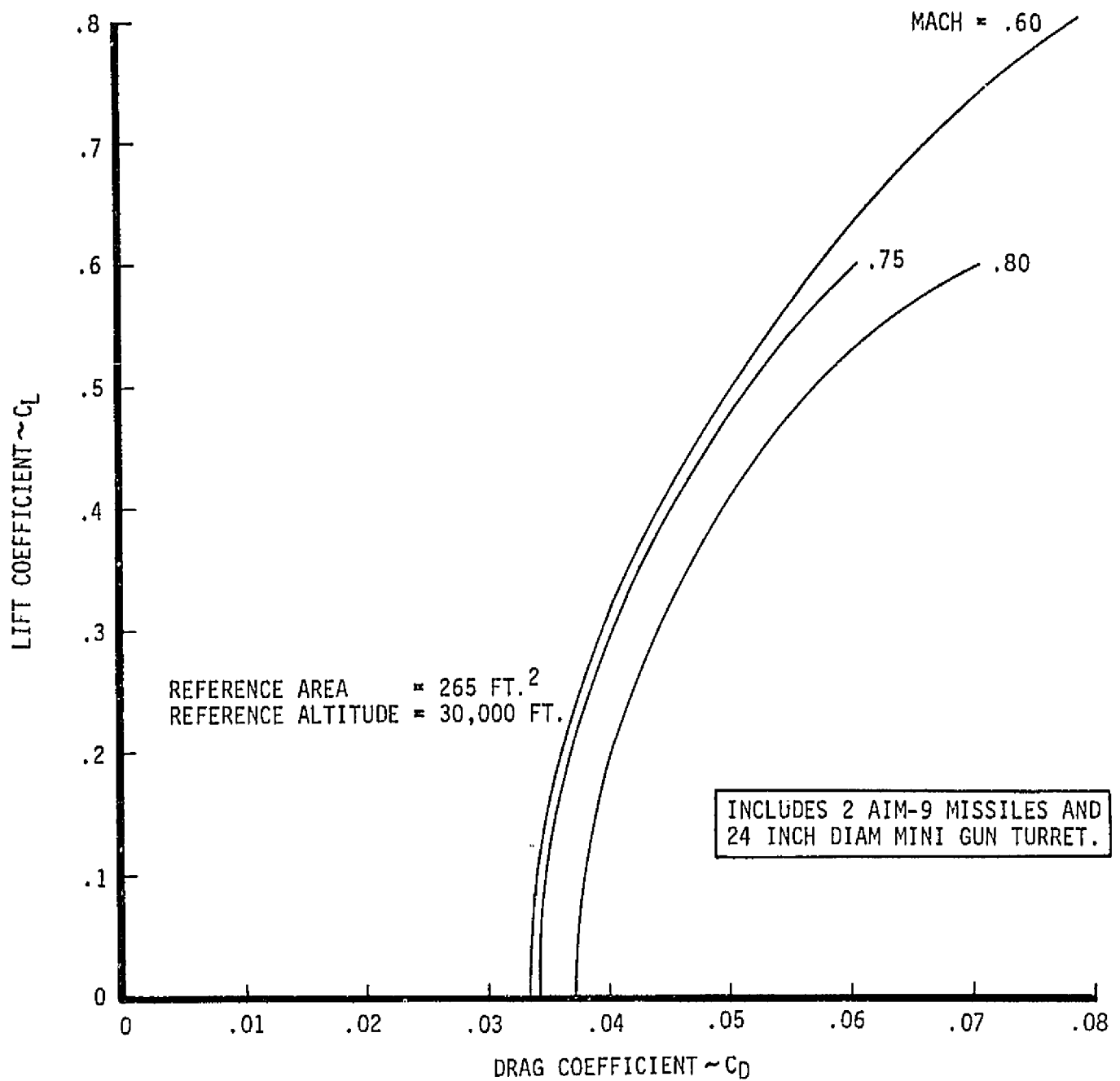

Figure 3.1-12.-Trimmed Drag Polar LCFA 1041-132 (CSAR)

Table 3.1-1.-Lift/Cruise Fan NASA/Navy VISTOL

	Mission sized weights				
	A5W	Surface attack	Survival lance	CSAR	VOB
WING	2010	1510	1630	1890	2360
HORIZONTAL TAIL	270	230	250	280	310
VERTICAL TAIL	140	140	140	140	140
BODY & STRAKE	2870	2470	2840	3610	4600
MAIN GEAR	1100	1040	1070	1070	1160
NOSE GEAR	190	180	190	190	200
NACELLE OR ENG SECTION	2300	2300	2300	2300	2640
AIR INDUCTION					
10% WT REDUCTION	890	790	840	950	1140
STRUCTURE	(7930)	(7080)	(7580)	(8530)	(10270)
FANS (3)	1320	1320	1320	1320	1320
ENGINE (2) ADV. ALLISON T701	2620	2620	2620	2620	3540
ENGINE ACCESSORIES	100	100	100	100	150
FUEL SYSTEM	350	460	280	550	400
ENGINE CONTROLS	80	80	80	80	110
STARTING SYSTEM	80	80	80	80	120
DRIVE SYSTEM	2860	2860	2860	2860	3440
PROPULSION	(7410)	(7520)	(7340)	(7610)	(9080)
AUXILIARY POWER UNIT					
INSTRUMENTS & NAV EQUIP	250	250	250	250	260
SURFACE CONTROLS	750	680	710	710	790
HYDRAULIC/PNEUMATIC	300	270	290	290	300
ELECTRICAL	650	480	650	590	590
AVIONICS	2700	580	3950	580	580
ARMAMENT	310	60		850	
FURNISHINGS & EQUIP	870	680	870	720	590
AIR COND & ANTI-ICING	650	490	650	540	540
AUXILIARY GEAR					
RADAR REFLECTIVITY RED.					
LOAD & HANDLING	20	20	20	140	270
FIXED EQUIPMENT	(6500)	(3510)	(7390)	(4670)	(3920)
WEIGHT EMPTY	21900	18110	22310	20810	23270
CREW	720	540	720	720	540
CREW PROVISIONS	180	150	210	280	250
OIL & TRAPPED OIL	90	90	90	90	110
UNAVAILABLE FUEL	110	90	90	90	130
PAYLOAD PROVISIONS	500	200		100	
WEAPON BAY FUEL PROV					
NON-EXP USEFUL LOAD	(1600)	(1070)	(1110)	(1280)	(1030)
OPERATING WEIGHT	23500	19140	23420	22090	24300
TORPEDOES (2)	1060				
SONOBUOYS (50)	1760				
HARPOONS (2)		2200			
PAYLOAD (INCL EXP PEN AIDS)					5000
FUEL INTERNAL	11430	8630	8800	8830	13000
SIDEWINDERS (2)		340		340	
AMMO (1000 RND)				70	
RESCUED PERSONNEL (2)				400	
STD GROSS WEIGHT	37750	30350	32220	31730	42300
FLT DES. GROSS WEIGHT	33180	26900	28700	28200	37100
n AT FDGW	3.0	3.0	3.0	5.0	3.0
M AT S.L.	0.6	0.6	0.6	0.8	0.6

Table 3.1-2.-LCFA Configurations--Point Design Mission Summaries

W/S $\approx$ 120 lb/ft <sup>2</sup> Standard day Advanced DDA T701 engines/VP fans							
Mission/ configuration number	S <sub>wing</sub> (ft <sup>2</sup> )	(L/D) <sub>max</sub>	(M(L/D)) <sub>max</sub>	Mission fuel	OEW	Mission GW	Mission F W
ASW/-128	310	11.82 (M = 0.6)	8.45 (M = 0.75)	11430	23500	37750	0.9
Surveillance/-129	265	10.34 (M = 0.6)	7.01 (M = 0.7)	8800	23420	32220	1.05
VOD/-130	350	11.45 (M = 0.6)	8.18 (M = 0.75)	13000	24300	42300	—
SA/-131	250	9.79 (M = 0.6)	6.80 (M = 0.75)	8630	19180	30350	1.12
CSAR/-132	265	10.58 (M = 0.6)	7.45 (M = 0.75)	8836	22090	31730	1.07

Notes:

1. VOD configuration (3 engines)
2. Mission calculations include 5% SFC tolerance
3. All mission fuel carried internally

*Table 3.1-3.-Point Design Weight Summary, Mission-Sized Airplanes*

Configuration	LCFA-128	LCFA-131	LCFA-129	LCFA-132	LCFA-130
Mission	ASW	SA	STJRV	CSAR	VOD
Operating weight, lb	23 500	19 180	23 420	22 090	24 300
Payload, lb	2 820	2 540	0	810	5 000
Fuel, lb	11 430	8 630	8 800	8 830	13 000
Mission gross weight, lb	37 750	30 350	32 220	31 730	42 300
Mission T.O., F/W	0.9	1.12	1.05	1.07	
Emergency landing weight, lb	24 500	20 180	24 420	23 090	30 300
Wing area, ft <sup>2</sup>	310	250	265	265	350
Lift/Cruise fan diameter, in.	62	62	62	62	62

### 3.2 Multi-Mission Aircraft

Comparison of the point designs from the standpoint of emergency weight, and mission weight and payload led to selection of the ASW as the basis for the multi-mission airplane. Model 1041-128 was renamed 1041-133-1, and became the ASW version of the multi-mission airplane. For convenience the other versions of the multi-purpose airplane were given dash numbers on the 1041-133 designation:

Antisubmarine (ASW)	1041-133-1
Surveillance	1041-133-2
Vertical Onboard Delivery (VOD)	-3
Surface Attack (SA)	-4
Combat (Strike) Search & Rescue (CSAR)	-5

The multi-mission airplane concept is conceived as being a single airplane design with only minor changes which are required by the different mission roles. Except for the VOD airplane, the same wing, flight deck, propulsion and control system will be used for all the models.

As a result of continuing design and analysis, the weights and thrust used for the multi-mission airplanes are slightly different from the point designs. For example, the point design ASW (-128) airplane had a mission GW of 37,750 lbs; the multi-mission ASW (-133-1) has a mission GW of 38,390 lbs. The maximum emergency thrust for the two engine airplane, is 25,300 lbs. That is after an engine failure with one engine driving three fans. For the VOD, two engines driving three fans after an engine out, the emergency thrust is 39,400 lbs. This performance became available in June 1975. The performance of the multi-mission aircraft was modified to account for the differences. The data is in Appendix B.

#### 3.2.1 Multi-Mission Summary

A summary of the five multi-mission airplanes is presented to show the overall capability of the system. A more detailed description of the ASW version is presented in Section 3.3 and represents the entire family.

A comparison of the airplanes in the different roles is shown in table 3.2-1.

Table 3.2-1.-Multimission Aircraft Comparison

Fan Diameter = 62 in. Wing Area 310 ft<sup>2</sup>

Airplane	1041-133-1	1041-133-2	1041-133-3	1041-133-4	1041-133-5
Mission	ASW	SURV	VOD	SA	SAR
No. of engines	2	2	3	2	2
Wetted area, ft <sup>2</sup>	1674	1947	1937	1674	1674
Body: Volume, ft <sup>3</sup>	934	934	1890	934	934
Density, lb/ft <sup>3</sup>	22.8	16.9	12.5	14.1	13.4
Mission T.O. weight	38 890	33 360	42 520	31 250	30 180
Mission T.O. F/W 	0.89	1.02	1.01	1.09	1.10

 Sea level 90° F day.

The ability to perform the specified mission from a vertical takeoff is approached by all the aircraft except the ASW which has a  $F/W = 0.89$ . On Table 3.2-2 the weight for the five versions are summarized. The empty weight cost of using a single wing area and fuselage causes the surveillance airplane to become the most critical from an emergency weight standpoint; it is still within the available thrust.

### 3.2.2 Multi-Mission Performance

The performance and drag polars of the five versions of the multi-mission aircraft are presented in Figures 3.2-1 through 3.2-17. The ASW (1041-131-1) was the baseline airplane. Drag and weight estimates of the other four were taken as increments to the ASW. The ASW three-view is shown on Figure 3.2-1. The trimmed drag polar, without external stores for the four two engine aircraft is shown in Figure 3.2-2. The complete buildup of ASW aerodynamics and performance is described in Section 3.3.

The surveillance airplane (1041-133-2) three view is in Figure 3.2-3. The drag increment due to the rotodome is shown on Figure 3.2-4. The mission performance is on Figure 3.2-5. The mission  $F/W$  at T.O. is 1.02 at sea level and  $90^{\circ}F$ . It could be performed from a vertical takeoff with acceleration margin reduced from  $F/W = 1.05$ . The level flight envelope is in Figure 3.2-6. The early drag rise of the rotodome cause the high speed to be drag limited at  $M = \quad$ .

The VOD airplane (1041-133-3) three view is in Figure 3.2-7. The drag polar is shown in Figure 3.2-8 and the mission calculation on Figure 3.2-9. The flight envelope is shown on Figure 3.2-10. The mission takeoff  $F/W$  is 1.01. Just possible for VT0.

The surface attack (1041-133-4) three view is in Figure 3.2-11. The drag increment for the external stores is in Figure 3.2-12. Mission performance in Figure 3.2-13 with VT0 from an  $F/W = 1.09$ . The flight envelope is in Figure 3.2-14.



The CSAR version (1041-133-5) is in Figure 3.2-15. There are no external stores so that the polar in Figure 3.2-2 applies. The mission performance is in Figure 3.2-16. The initial takeoff is vertical at a  $F/W = 1.1$ . The flight profile is shown in Figure 3.2-17.

Table 3.2-2.-Multimission Weight Summary

Configuration	133-1	133-4	133-2	133-5	133-3
Mission	ASW	SA	SURV	CSAR	VOD
Operating weight, lb	23 500	20 280	23 970	21 600	24 400
Payload, lb	2 820	2 540	0	810	5 000
Fuel, lb	12 070*	7 990	9 390	8 370	13 080
Mission gross weight, lb	38 390	31 250	33 360	30 780	41 520
Emergency landing weight, lb	24 500	21 280	24 970	22 600	30 440
Emergency thrust, lb	25 300	25 300	25 300	25 300	39 400

\*Includes weight of external tanks.

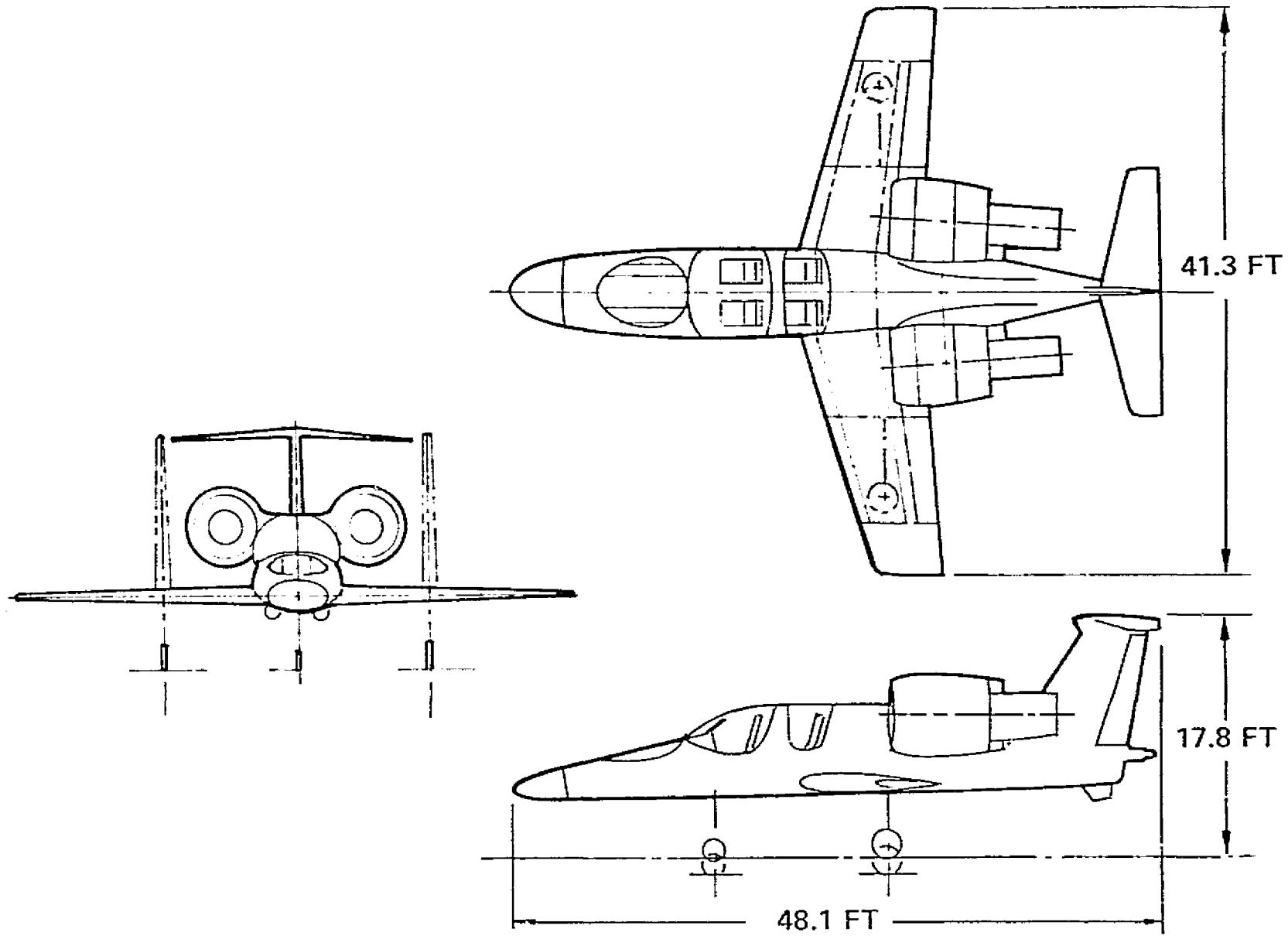

Figure 3.2-1.-ASW Airplane, Model 1041-133-1

LCFA CONFIGURATIONS 1041-133-1(ASW), -133-4(5A),  
-133-5(CSAR), -133-2 (SURVEILLANCE)

WING REFERENCE AREA = 310 FT<sup>2</sup>  
REFERENCE ALTITUDE = 30000 FT  
EXTERNAL STORES OFF

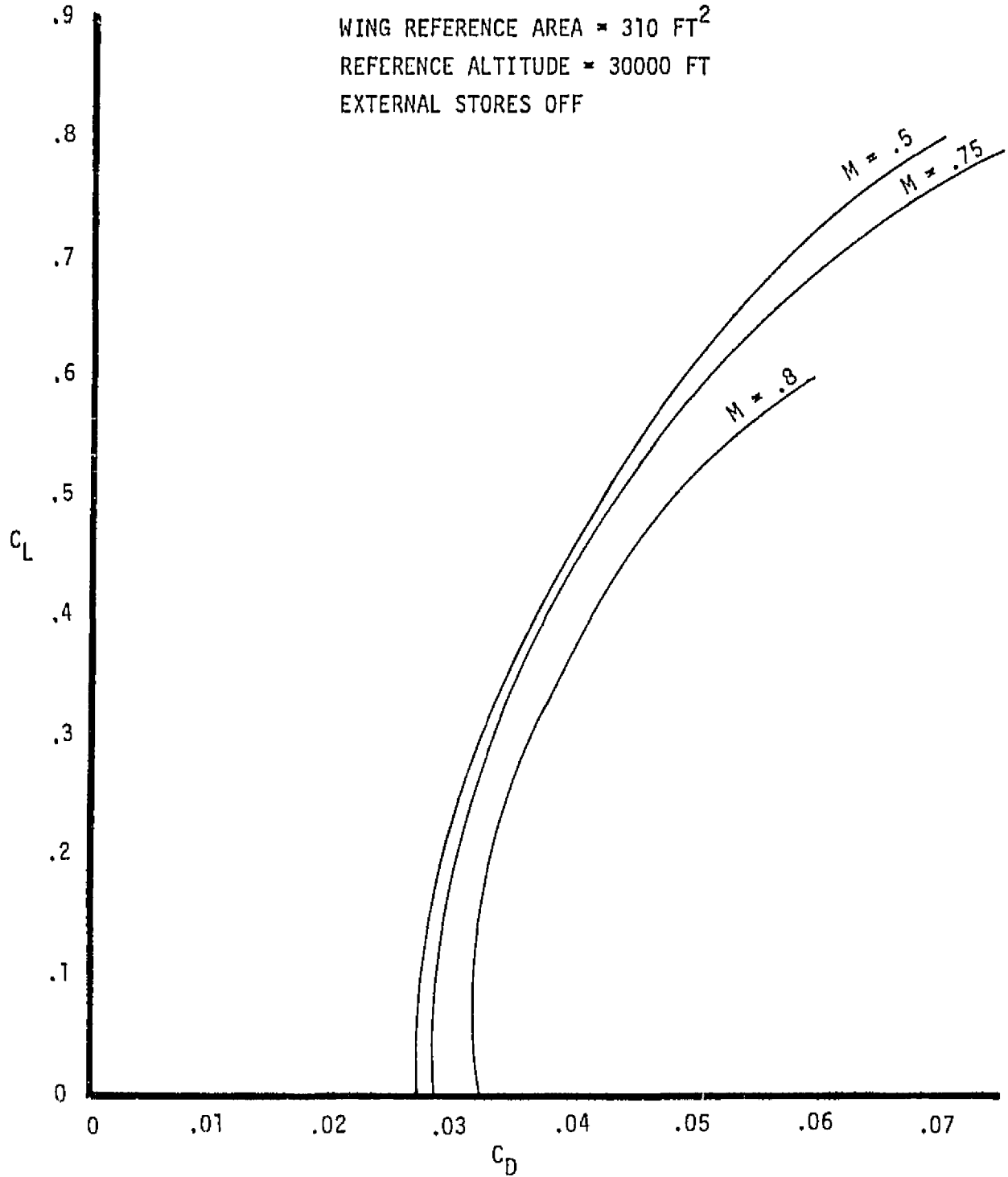

Figure 3.2-2.—Trimmed Drag Polar

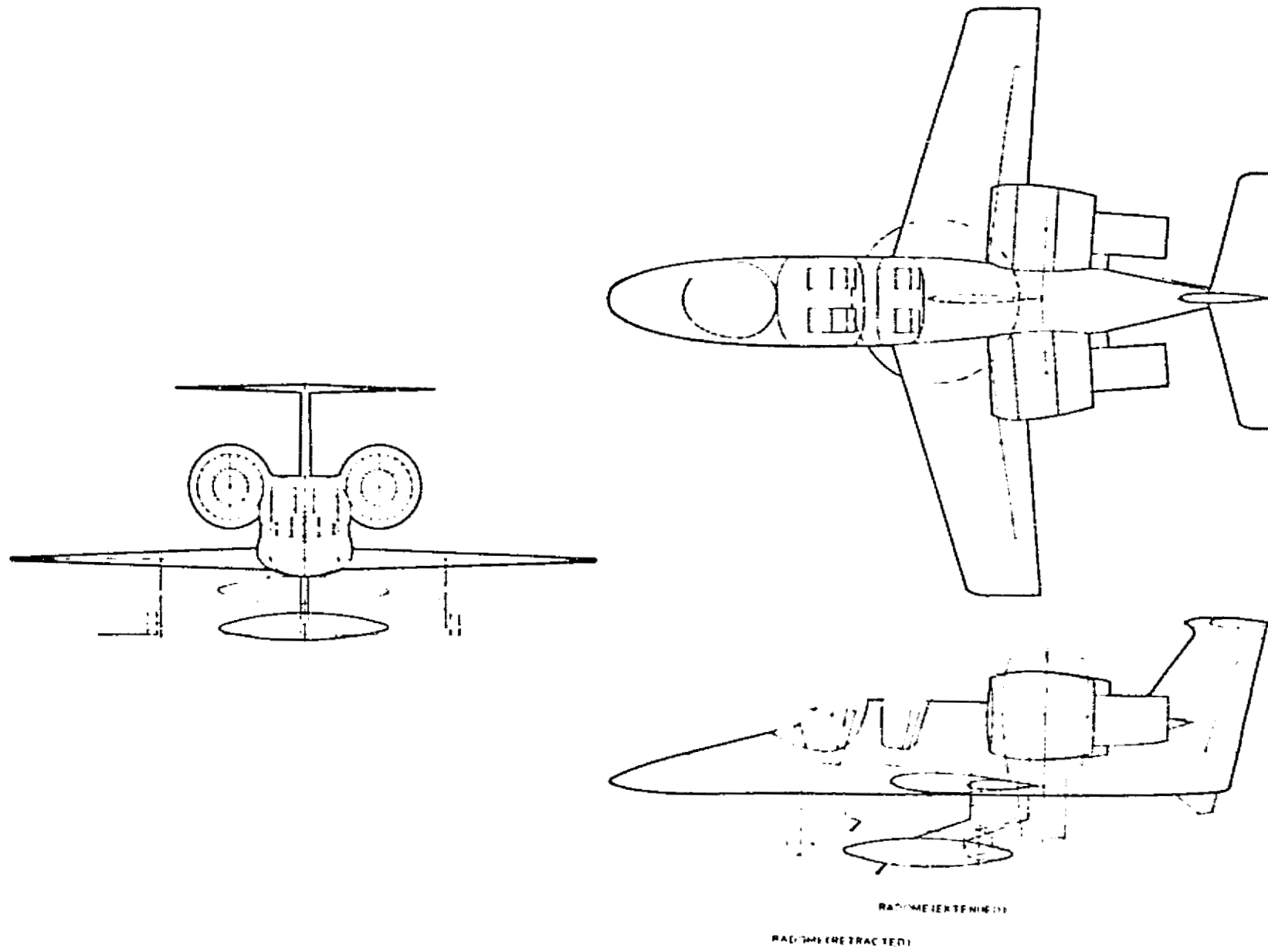

Figure 3.2-3.—Multimission Airplane Surveillance Role, Model 1041-133-2

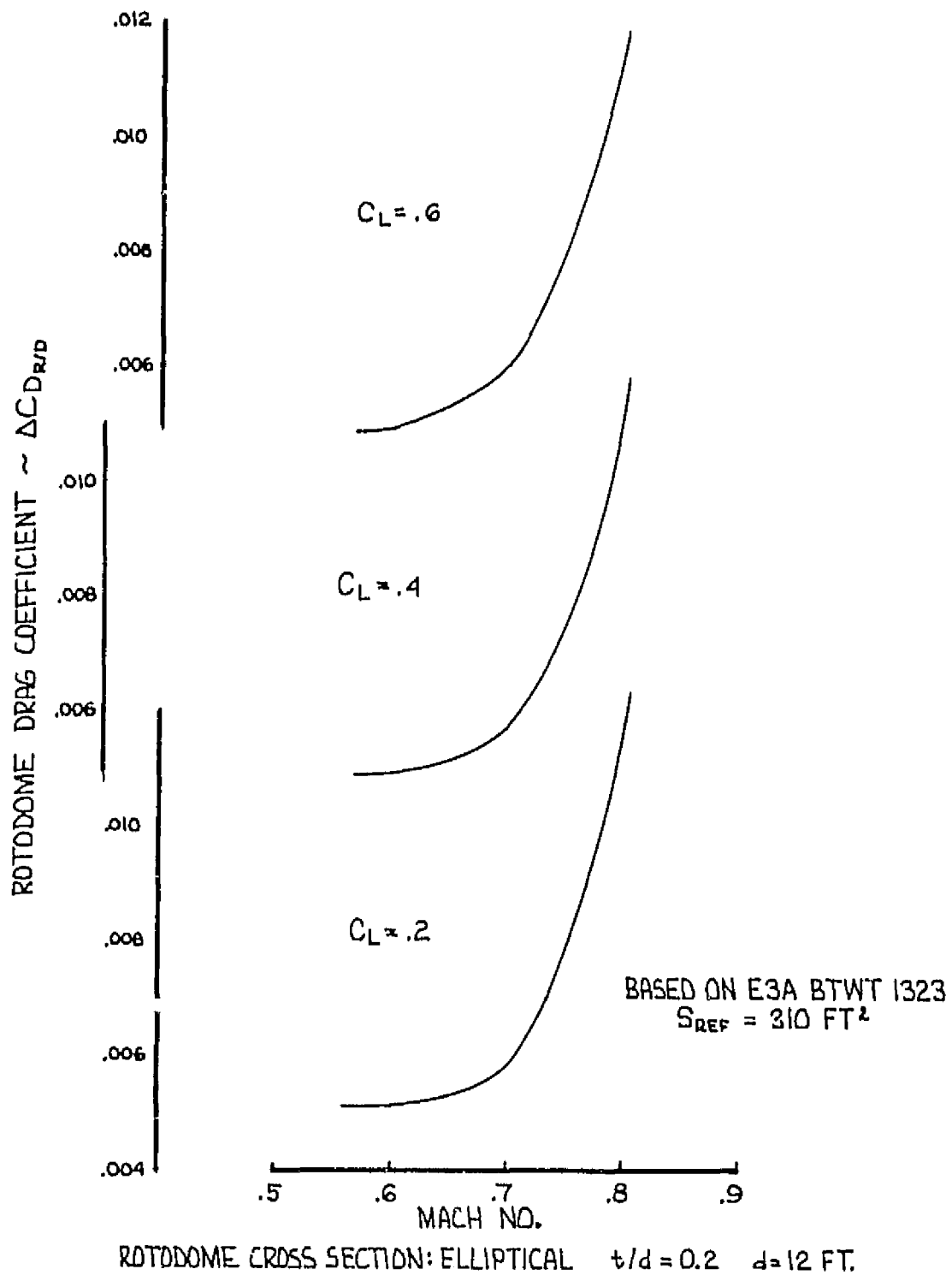
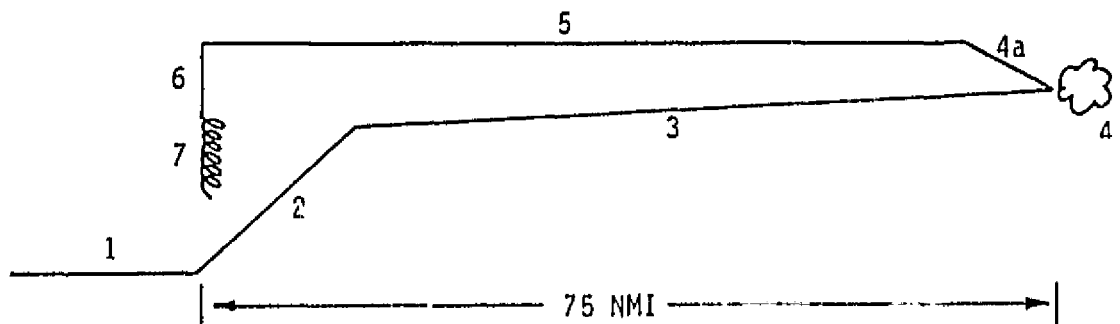

Figure 3.2-4.-LCFA 133-2 Surveillance Rotodome and Support Strut Drag



SEGMENT	SPEED	TIME (HRS.)	DISTANCE (NMI)	FUEL* (LBS.)	A/P WEIGHT @ START OF SEGMENT
1) WARM-UP, TAKEOFF, ACCEL TO CLIMB SPEED	--	.042	--	331	33357
2) CLIMB TO BCav	280 CAS	.079	29	526	33026
3) CRUISE @ BCav (INITIAL ALTITUDE=32000 FT)	M=.75	.095	46	269	32500
4) LOITER @ 31000 FT	M=.60	4.000	--	7080	32231
a) CLIMB TO BCav	320 CAS	.028	12	121	25151
5) CRUISE @ BCav (INITIAL ALTITUDE=37000 FT)	M=.75	.146	63	285	25030
6) DESCEND TO SEA LEVEL	--	--	--	--	24745
7) LANDING ALLOWANCE AND RESEV AND RESERVE					
a) 10 MIN. LOITER @ S.L.	M=.28	.167	--	329	24745
b) 5% TOTAL INITIAL FUEL	--	--	--	446	24416
OEw+PAYLOAD					23970

\* 5% SERVICE TOLERANCE THROUGHOUT

Figure 3.2-5.-Mission Breakdown LCFA 1041-133-2 (Surveillance)

S.L.S, DAY  
WT. = 32200 LV LBS  
S<sub>REF</sub> = 310 FT<sup>2</sup>

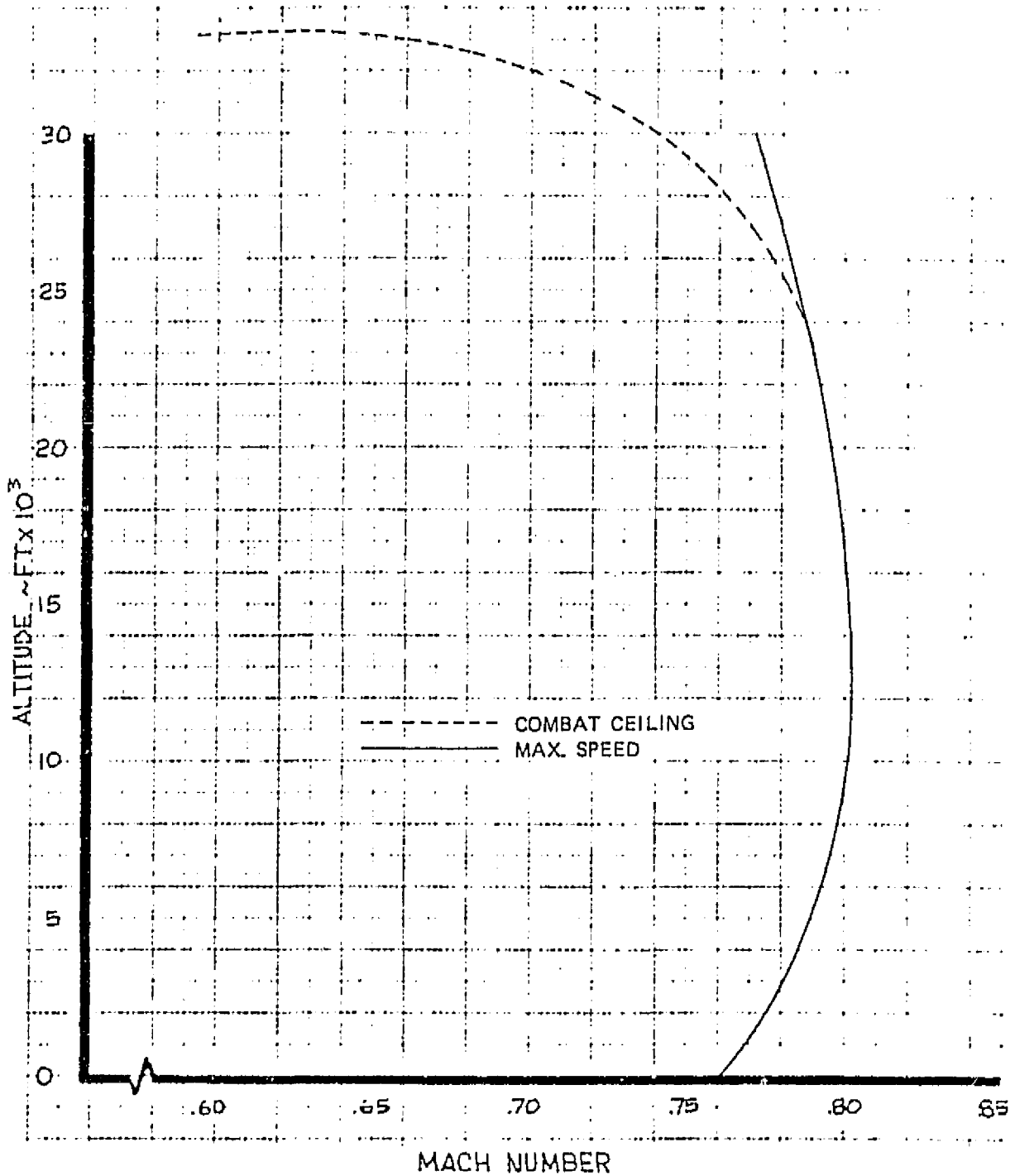

Figure 3.2-6.—Performance Capability, Model 1041-133-2



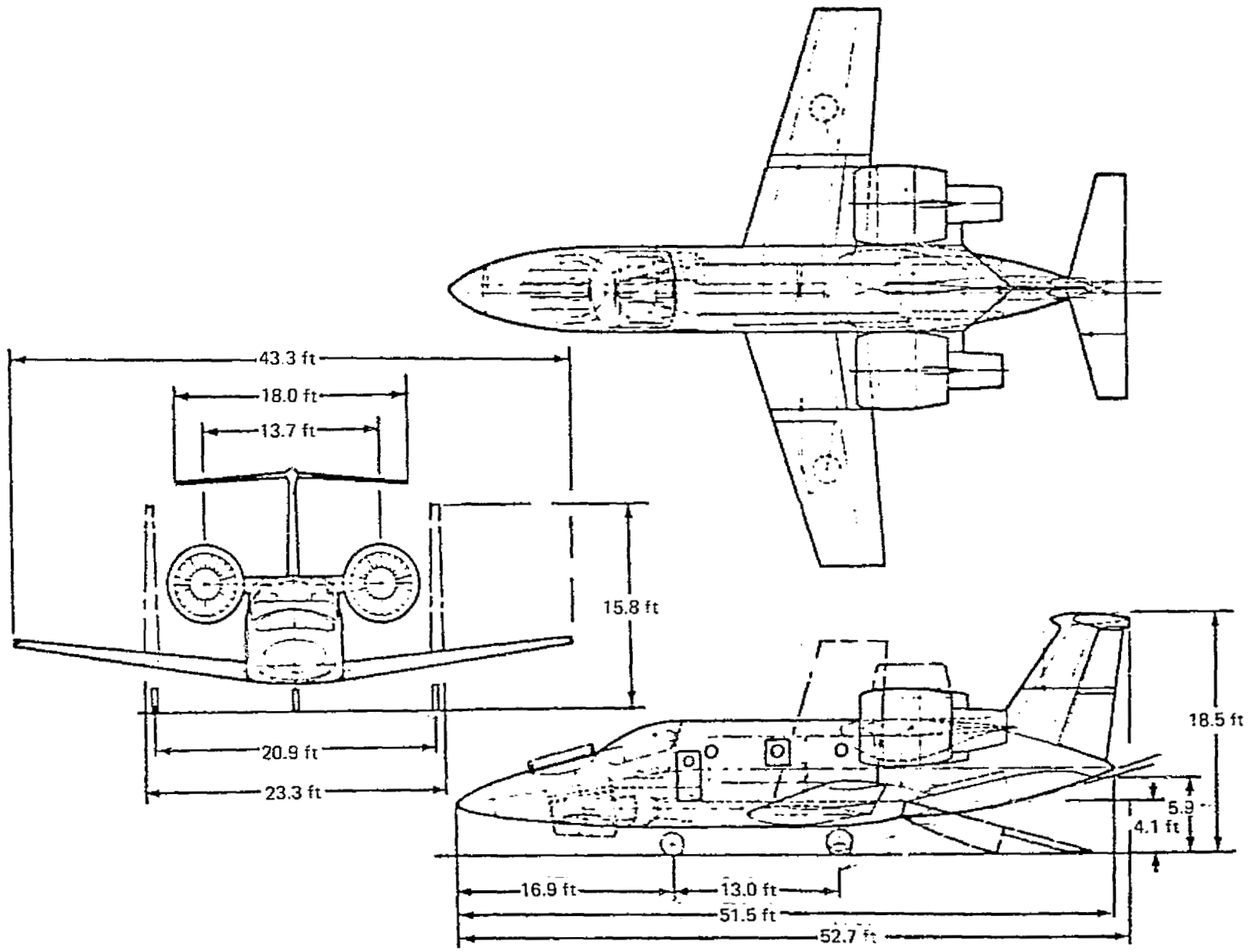

Figure 3.2-7.—Multimission Airplane, VOD Role, 1041-133-3

WING REFERENCE AREA = 310 FT<sup>2</sup>  
REFERENCE ALTITUDE = 35000 FT

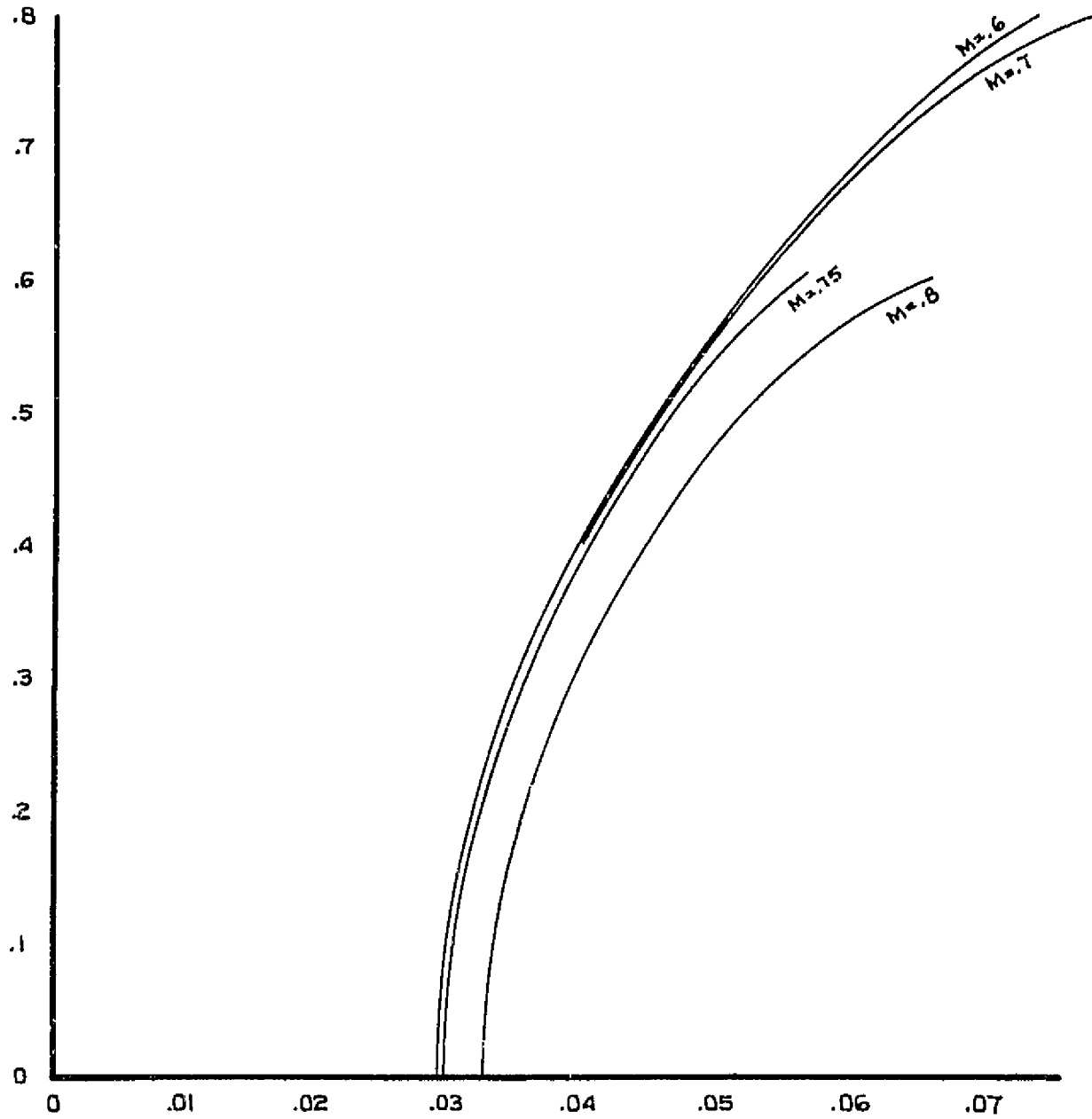
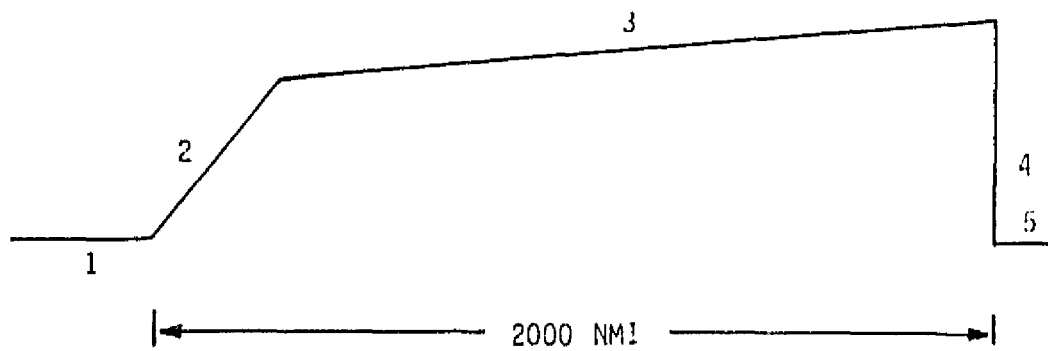

Figure 3.2-8.—Trimmed Drag Polar LCFA Configuration: 133-3 (VOD)



SEGMENT	SPEED	TIME (HRS.)	DISTANCE (NMI)	FUEL * (LBS.)	A/P WEIGHT @ START OF SEGMENT
1) WARM-UP, TAKEOFF, ACCEL. TO CLIMB SPEED	--	.042	--	346	42519
2) CLIMB TO BCAF	300 CAS	.110	42	727	42173
3) CRUISE @ BCAF (INITIAL ALTITUDE=29000 FT)	M=.75	4.499	1958	10590	41446
4) DESCEND TO SEA LEVEL	--	--	--	--	30856
5) LANDING ALLOWANCE AND RESERVE					
a) 20 MIN. LOITER @ S.L.	M=.32	.333	--	791	30856
b) 5% TOTAL INITIAL FUEL	--	--	--	625	30065
OEW + PAYLOAD					29440

\* 5% SERVICE TOLERANCE THROUGHOUT

Figure 3.2-9.-Mission Breakdown LCFA 1041-133-3 (VOD)

S.L.S. DAY  
WT. = 41000 LBS  
 $S_{REF} = 310 \text{ FT}^2$

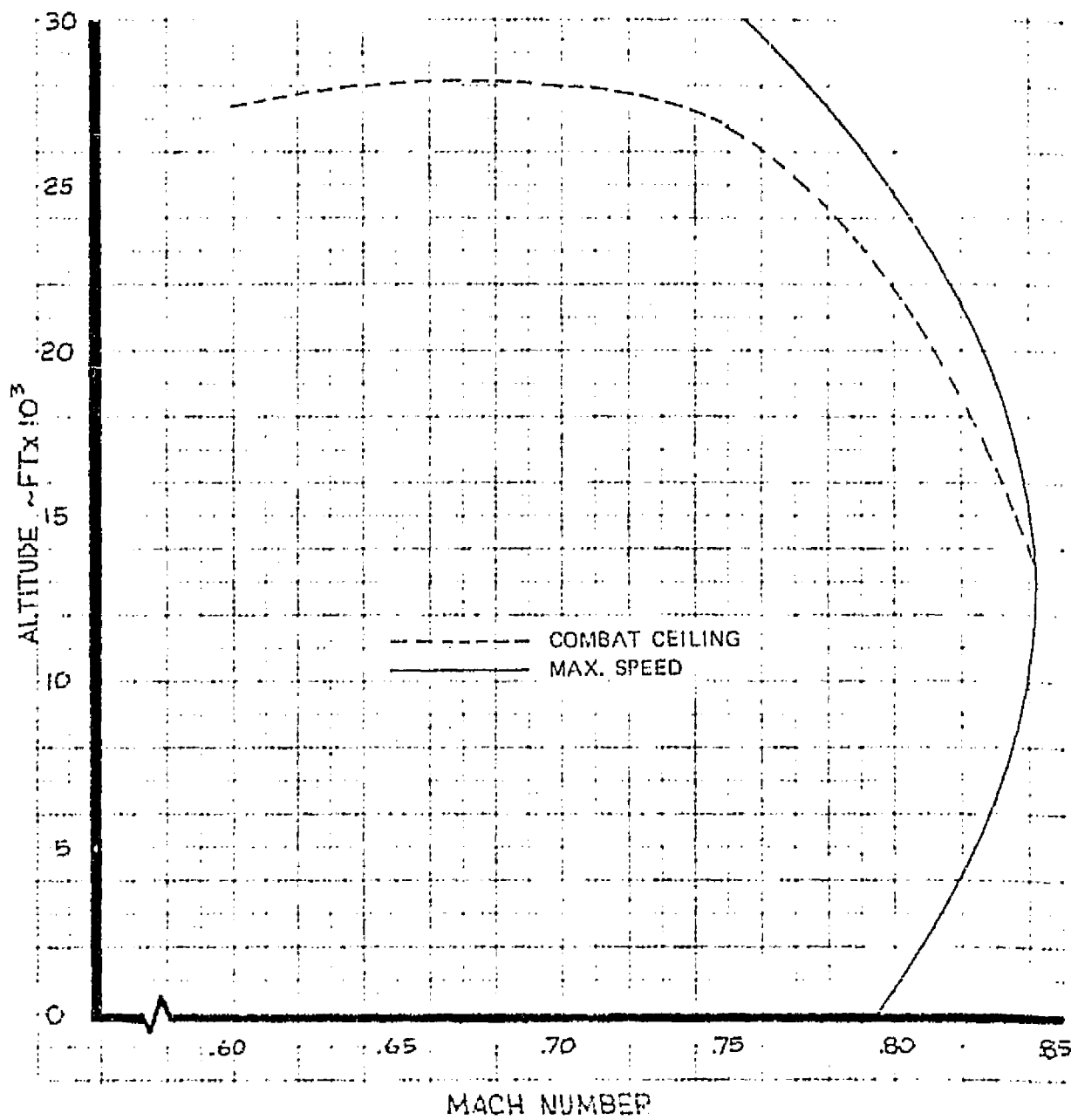

Figure 3.2-10.—Performance Capability, Model 1041-133-3

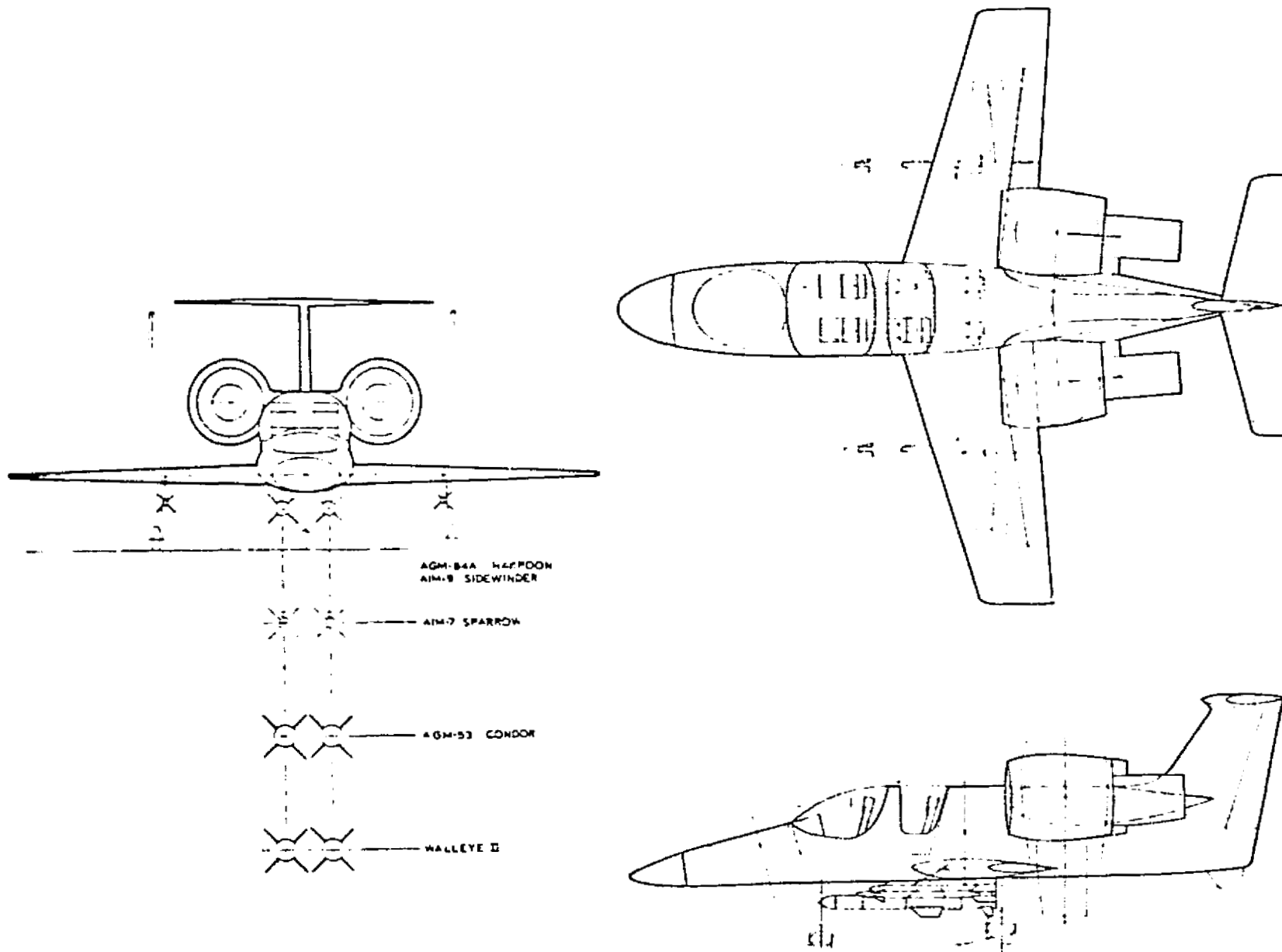

Figure 3.2-11.—Multimission Airplane Attack Role, Model 1041-133-4

$S_{REF} = 310 \text{ FT}^2$

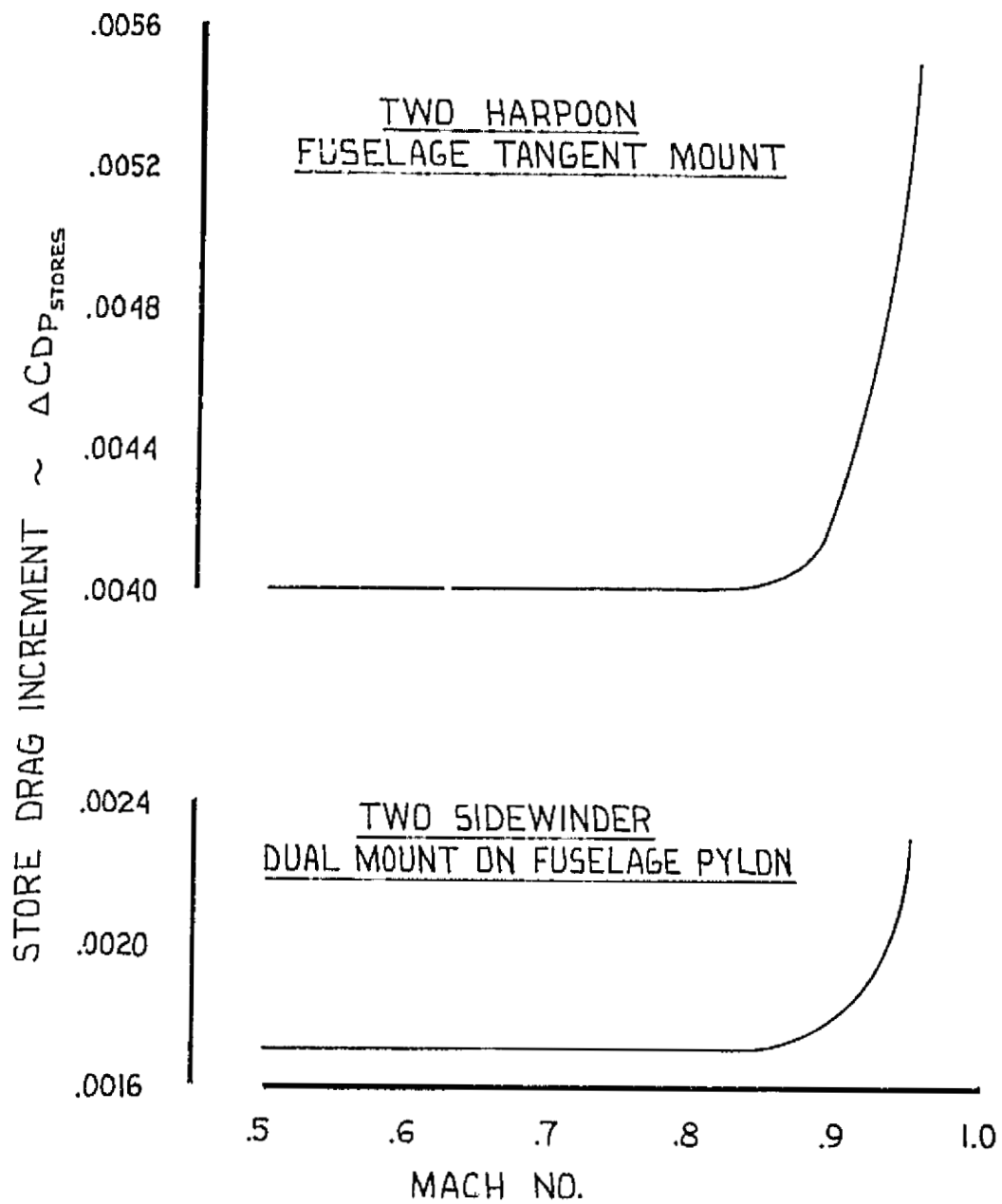
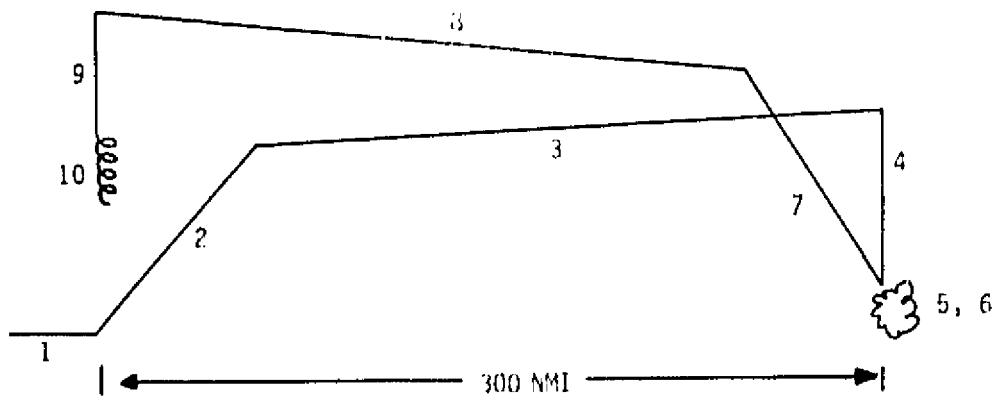

Figure 3.2-12.-LCFA 133-4 (SA) External Store Drag



SEGMENT	SPEED	TIME (HRS.)	DISTANCE (NMI)	FUEL * (LBS.)	A/P WEIGHT @ START OF SEGMENT
1) WARM-UP, TAKEOFF, ACCEL. TO CLIMB SPEED	--	.042	--	330	31250
2) CLIMB TO BCAF	290 CAS	.076	29	507	30920
3) CRUISE @ BCAF (INITIAL ALTITUDE=33000 FT)	M=.75	.630	271	1424	30413
4) DESCEND TO 20000 FT	--	--	--	-	28989
5) LOITER @ 20000 FT	M=.45	2.000	--	3662	28989
6) COMBAT @ 20000 FT	M=.80	.083	--	363	25327
7) CLIMB TO BCAF	350 CAS	.037	16	189	24964
8) CRUISE @ BCAF (INITIAL ALTITUDE=38000 FT)	M=.75	.660	284	1207	24775
9) DESCEND TO SEA LEVEL	--	--	--	--	23568
10) LANDING ALLOWANCE AND RESERVE					
a) 10 MIN. LOITER @ S.L.	M=.27	.167	--	348	23568
b) 5% TOTAL INITIAL FUEL	--	--	--	400	23220
OEW+PAYLOAD					22820

\* 5% SERVICE TOLERANCE THROUGHOUT

Figure 3.2-13.-Mission Breakdown LCFA 1041-133-4 (SA)

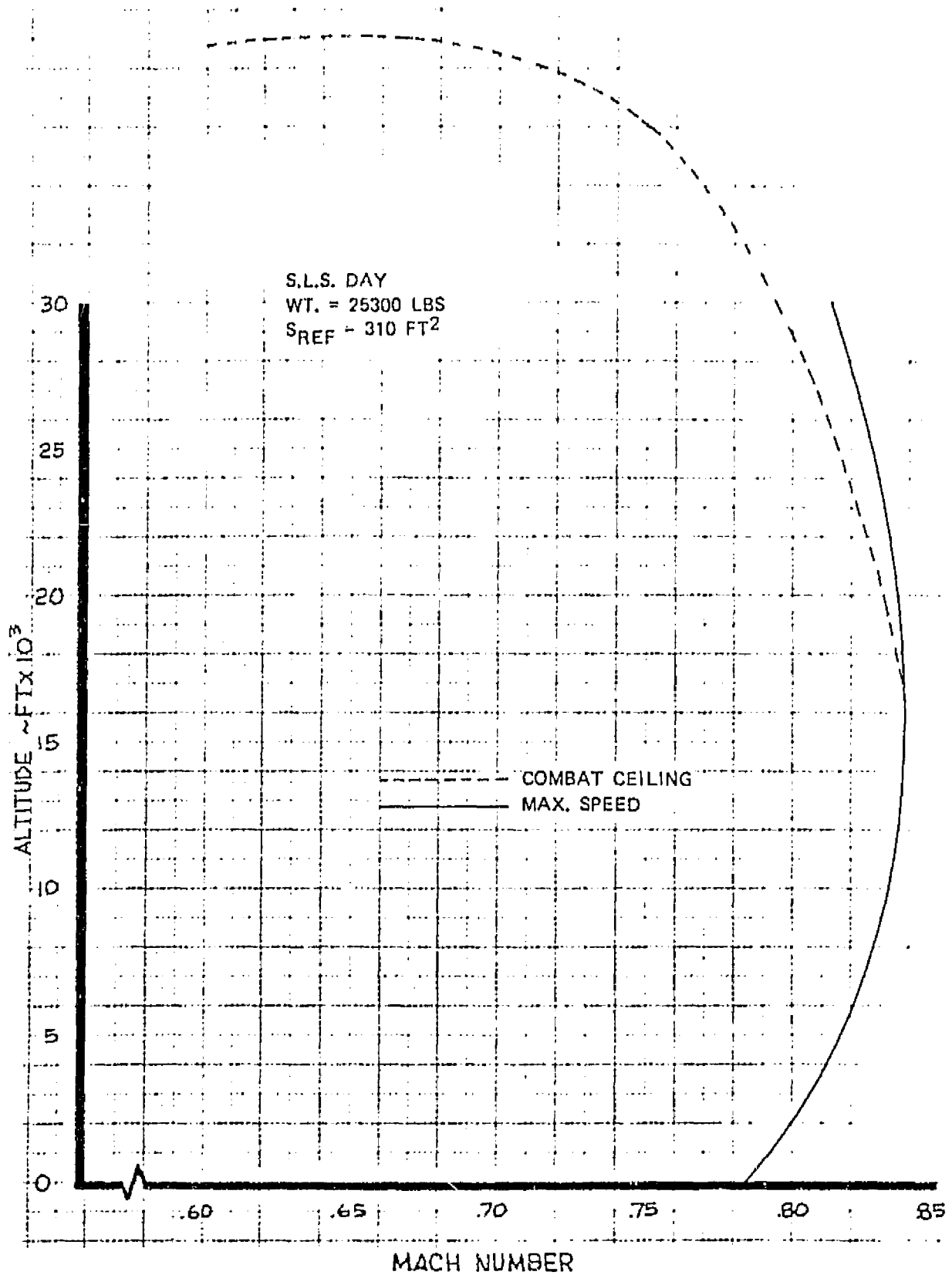

Figure 3.2-14.—Performance Capability, Model 1041-133-4



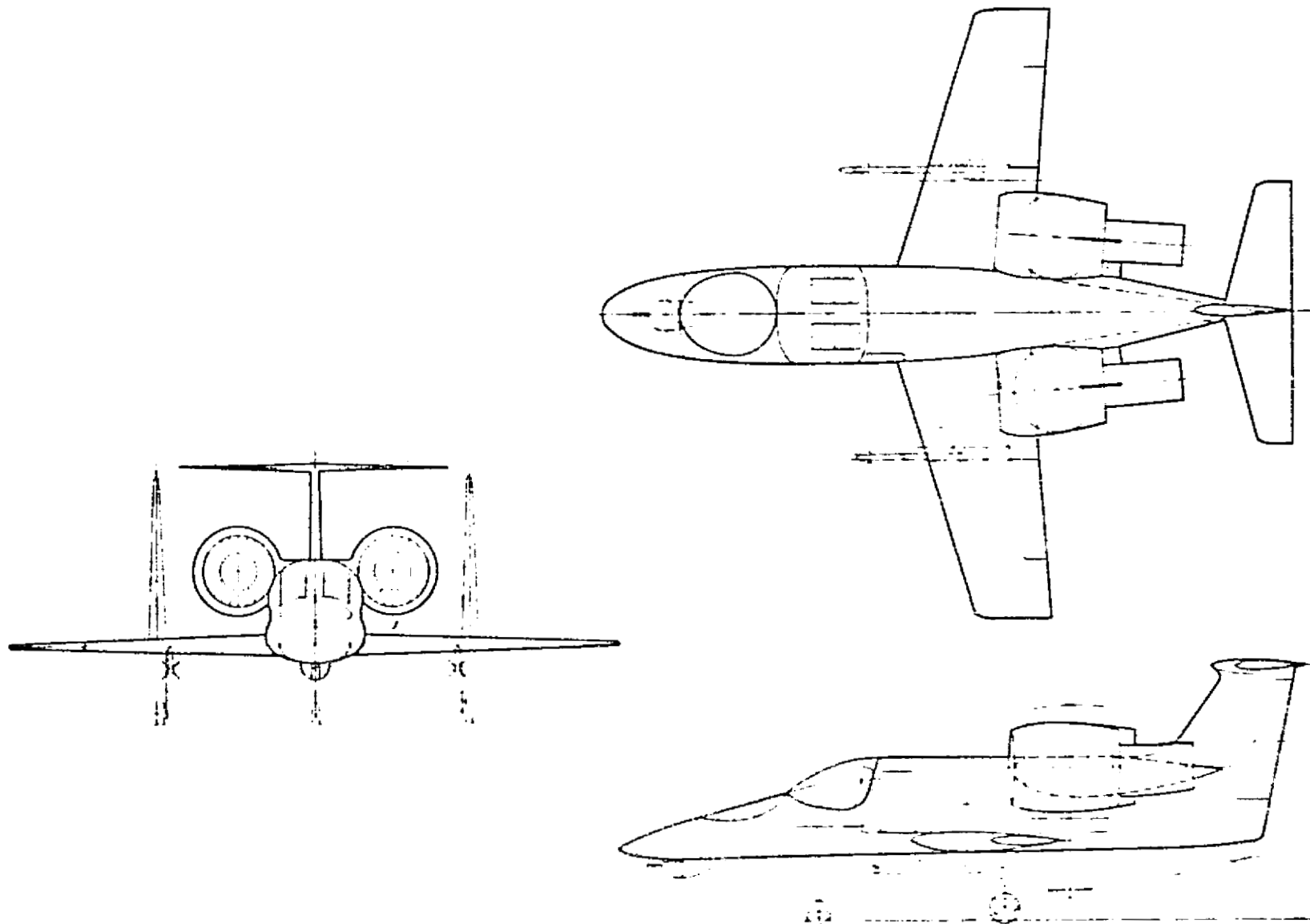
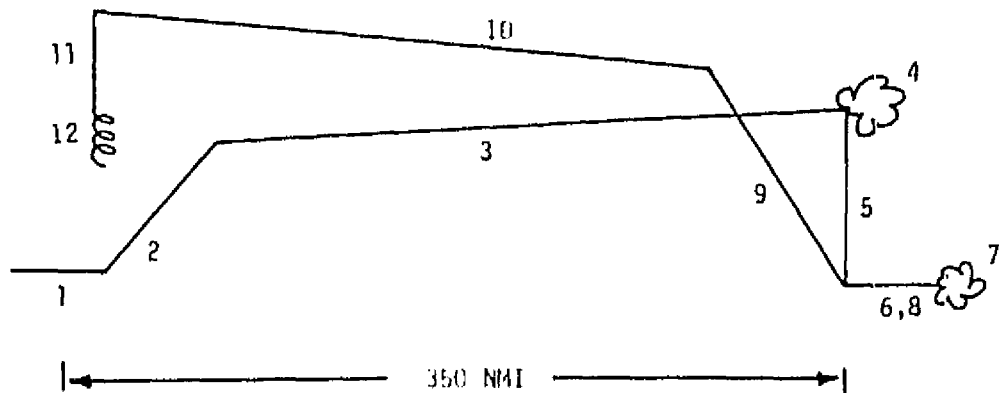

Figure 3.2-15.—Multimission Airplane CSAR Role, Model 1041-133-5



SEGMENT	SPEED	TIME (HRS.)	DISTANCE (NMI)	FUEL (LBS.)	A/P WEIGHT @ START OF SEGMENT
1) WARM-UP, TAKEOFF, ACCEL. TO CLIMB SPEED	--	.042	--	331	30769
2) CLIMB TO BCAF	300 CAS	.074	29	518	30438
3) CRUISE @ BCAF (INITIAL ALT. = 35000 FT)	M= .75	.746	321	1529	29920
4) LOITER @ 39,000 FT.	M= .75	.333	--	663	28391
5) DESCEND TO SEA LEVEL	--	--	--	--	27728
6) DASH AT M = .80	M= .80	.094	50	839	27728
7) PERSONNEL PICKUP (10 MIN. HOVER)	--	.167	--	1216	26889
8) Dash at M= .80	M= .80	.094	50	841	25673
9) CLIMB TO BCAF	300 CAS	.069	27	442	24832
10) CRUISE @ BCAF (INITIAL ALT. = 38000 FT.)	M= .75	.751	323	1260	24390
11) DESCEND TO SEA LEVEL	--	--	--	--	23130
12) LANDING ALLOWANCE AND RESERVE					
a) 10 MIN. LOITER @ S.L.	M= .28	.167	--	313	23130
b) 5% TOTAL INITIAL FUEL	--	--	--	407	22817
OEW+ PAYLOAD					22410

\* 5% SERVICE TOLERANCE THROUGHOUT

Figure 3.2-16.-Mission Breakdown LCFA 1041-133-5 (CSAR)

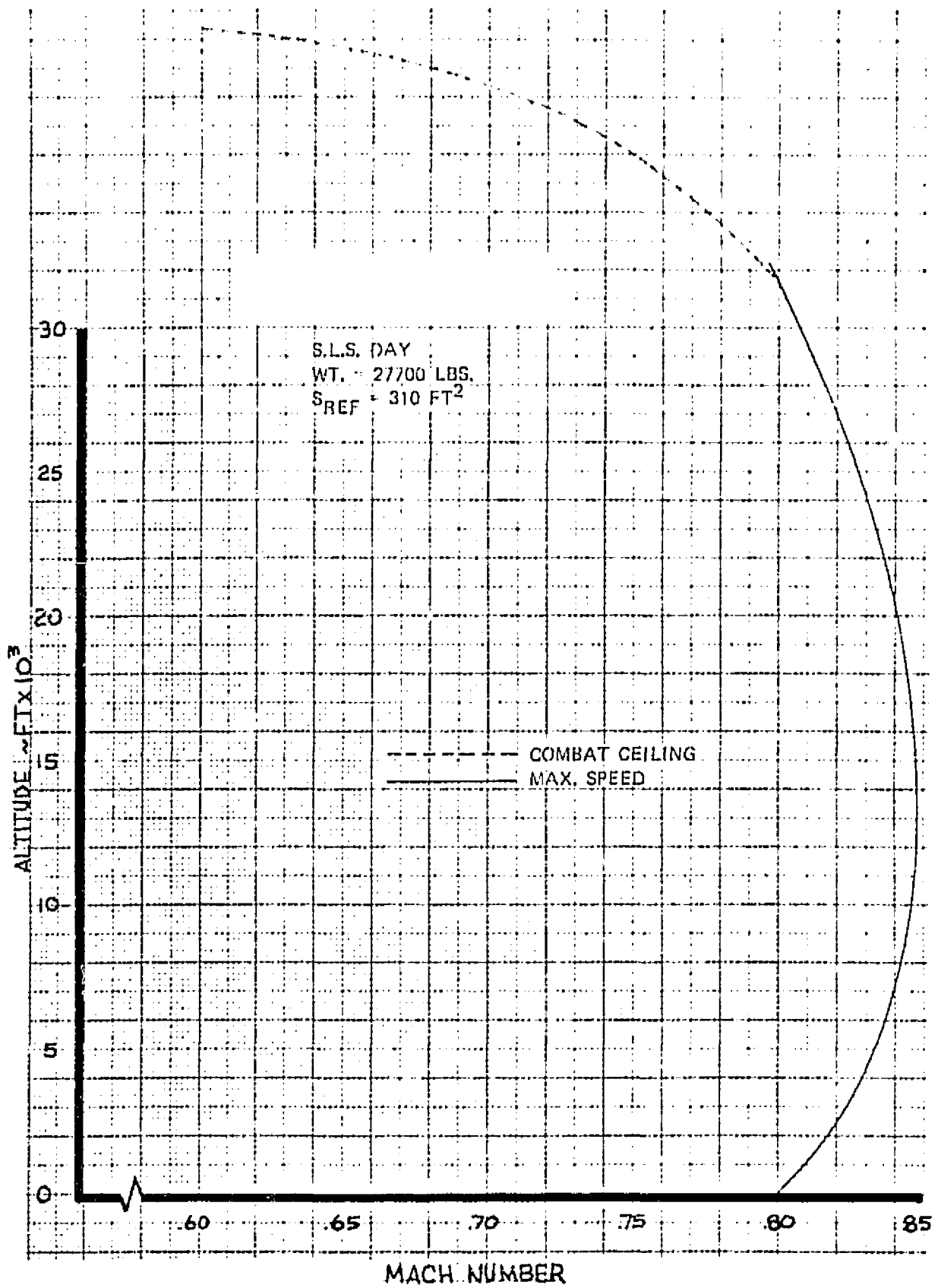

Figure 3.2-17.—Performance Capability, Model 1041-133-5

### 3.3 ASW Airplane Design, Model 1041-133-1

The ASW airplane as the baseline design is described in some detail. An isometric of this basic two engine arrangement is shown on Figure 1.02. The propulsion system installation is emphasized. Each engine drives through an overrunning clutch into the lift/cruise gearbox. This gearbox contains a reduction gear, which reduces engine RPM to fan RPM (11,500 RPM to 3,500 RPM) and a right angle bevel set which distributes power to the combiner gearbox or "T" box. Interconnecting shaft speed is equal to engine speed. At the "T" box power is distributed as required to the front fan, where a bevel set reduces the speed back to fan RPM. A clutch adjacent to the "T" box disconnects the front fan during conventional flight. Airplane accessories power is taken from the rear of the "T" box.

Thrust vector control during V/STOL operation is achieved by rotating the lift/cruise fan nacelles. The thrust vector angle of the nose fan is fixed  $15^{\circ}$  forward of vertical ( $\lambda = 75^{\circ}$ ); its magnitude is controlled with fan pitch. During V/STOL transitions as the lift/cruise vector is rotated and its moment arm about the c.g. changes, the nose fan thrust is changed to balance the system.

Three large benefits led to selection of thrust vectoring by nacelle rotation. In addition to minimizing the number of gearboxes and permitting an aerodynamically clean engine-wing integration, rotating the nacelles provides about 15% more vertical thrust at the lift/cruise fan than would otherwise be possible with the same engines.

Use of other propulsive arrangements was considered but the performance advantage of the selected arrangement overrides other considerations. A comparison of a rotating nacelle and thrust deflecting nozzle is shown in Figure 3.3.1.

The rotating nacelle has the engine placed behind the fan. The engine is supercharged by the fan and a single gearbox connects the engine and fan and provides the output for the interconnect system. For single engine operation the fan pressure ratio of 1.13 supercharges the engine for about 10% more power. When both engines are operating, the augmentation caused by supercharging is as much as 20%. The nozzle efficiency is about 98% of the ideal.

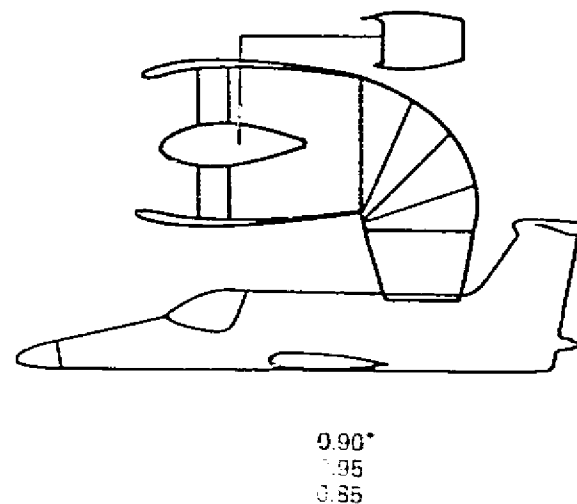
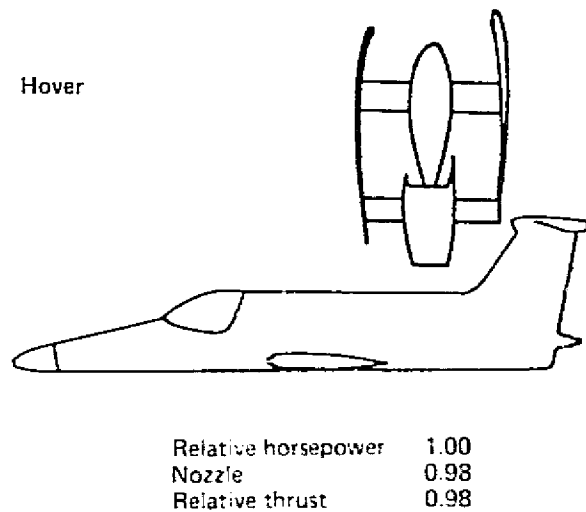
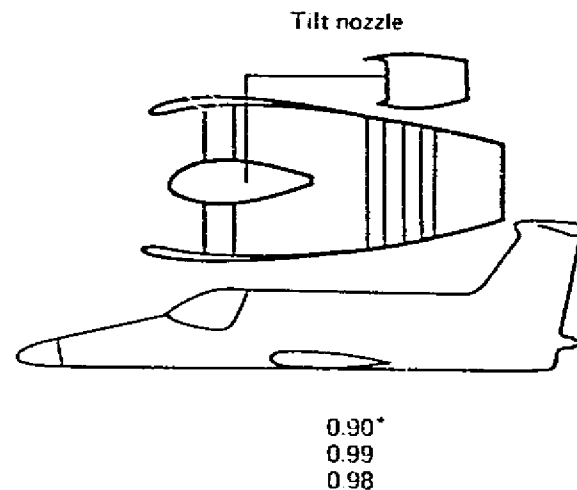
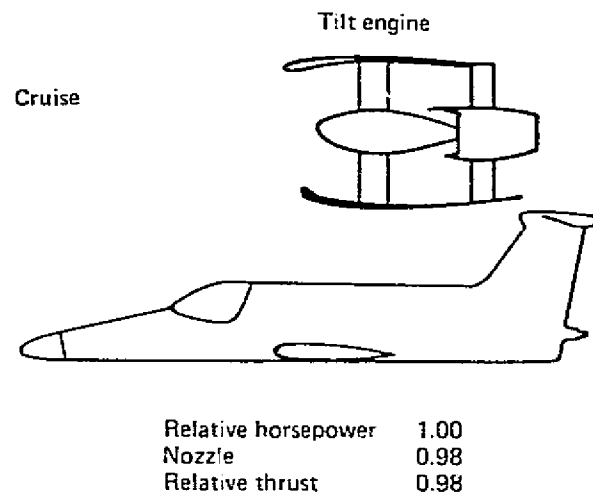

\*No fan supercharging.

Figure 3.3-1.—Propulsion Arrangements for Thrust Vectoring

For the tilt nozzle thrust deflection system the engine is separate from the fan. This is necessary to keep the point of action of the vertical thrust vector near the wing trailing edge without creating an unfavorable interference condition by blocking the wing and back pressuring the engine with the fan. The weight and complexity of two extra gearboxes are required by this separation. The supercharging action of the fan is lost, resulting in about 10% less power than would have been available with supercharging. In addition, a nozzle efficiency, including duct bend losses, approaching 95% may be possible. Thus, the thrust available is 85% of the ideal with supercharging.

### 3.3.1 Arrangement and Characteristics (1041-133-1)

Fig. 3.3.1-1 shows the general arrangement of Boeing Model 1041-133-1, multi-mission V/STOL airplane in its ASW role. It has a low wing, "T" tail and engine pods mounted on the aft body in an arrangement similar to the majority of today's small jet transports.

The design incorporates a number of special features to suit it for its role as a ship based V/STOL aircraft. The most important feature is the propulsion system. Two Allison advanced T701 turboshaft engines drive three Hamilton-Standard variable pitch fans by means of a mechanical drive system.

The wings fold just outboard of the engine pods. The planform of the airplane with wings folded is slightly smaller than that of the A-7. It is therefore assumed that the spotting factor relative to the A-7 is 1.0 or slightly less. Figure 3.3.1-2 shows the planforms of the two airplanes superimposed.

The landing gear is a conventional tricycle arrangement. The main gear attaches to the wing fold rib and retracts outboard. The nose gear retracts aft under the cockpit floor.

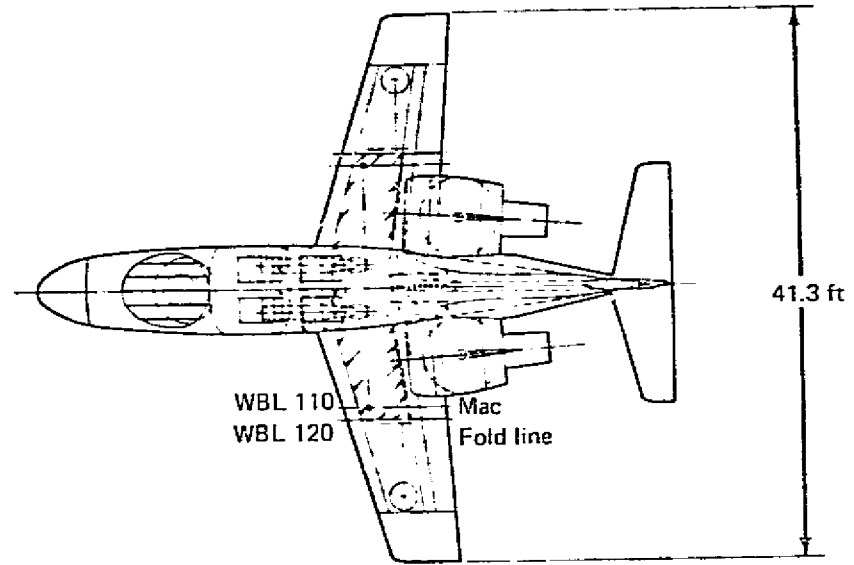
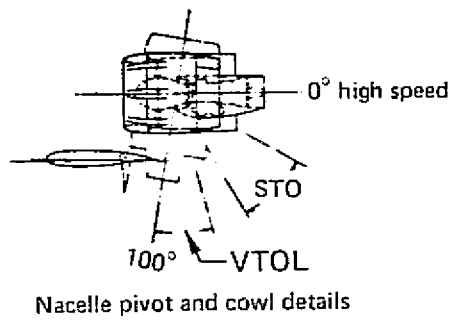

Wing area = 310 ft<sup>2</sup>  
Aspect ratio = 5.5  
Taper ratio = 0.5  
Thickness ratio root = 0.15  
0.10

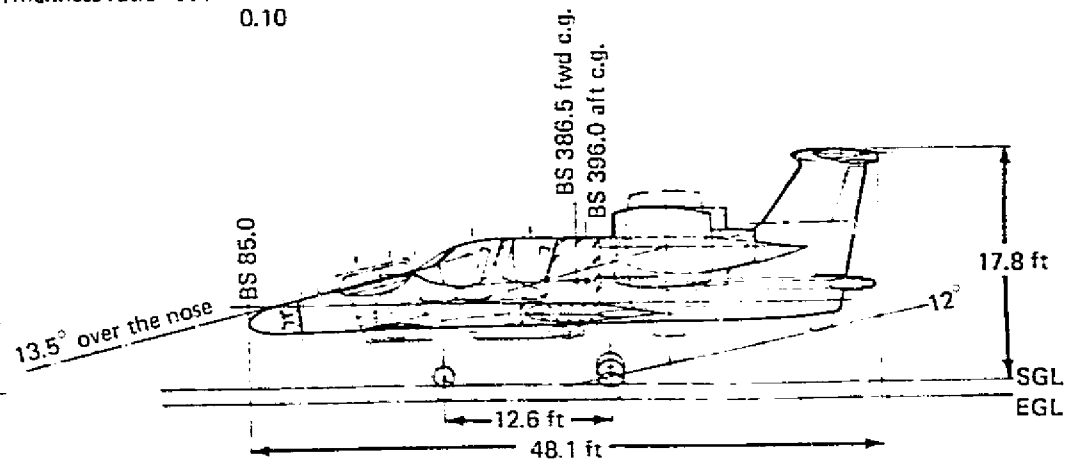
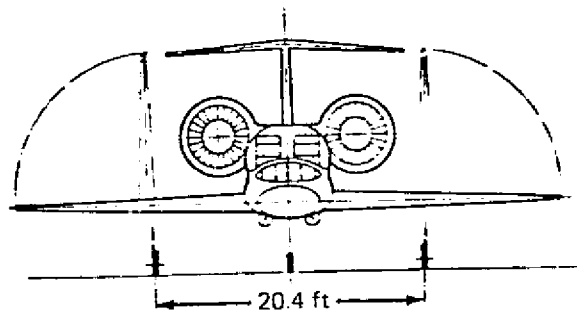

Figure 3.3.1-1.—General Arrangement, Model 1041-133

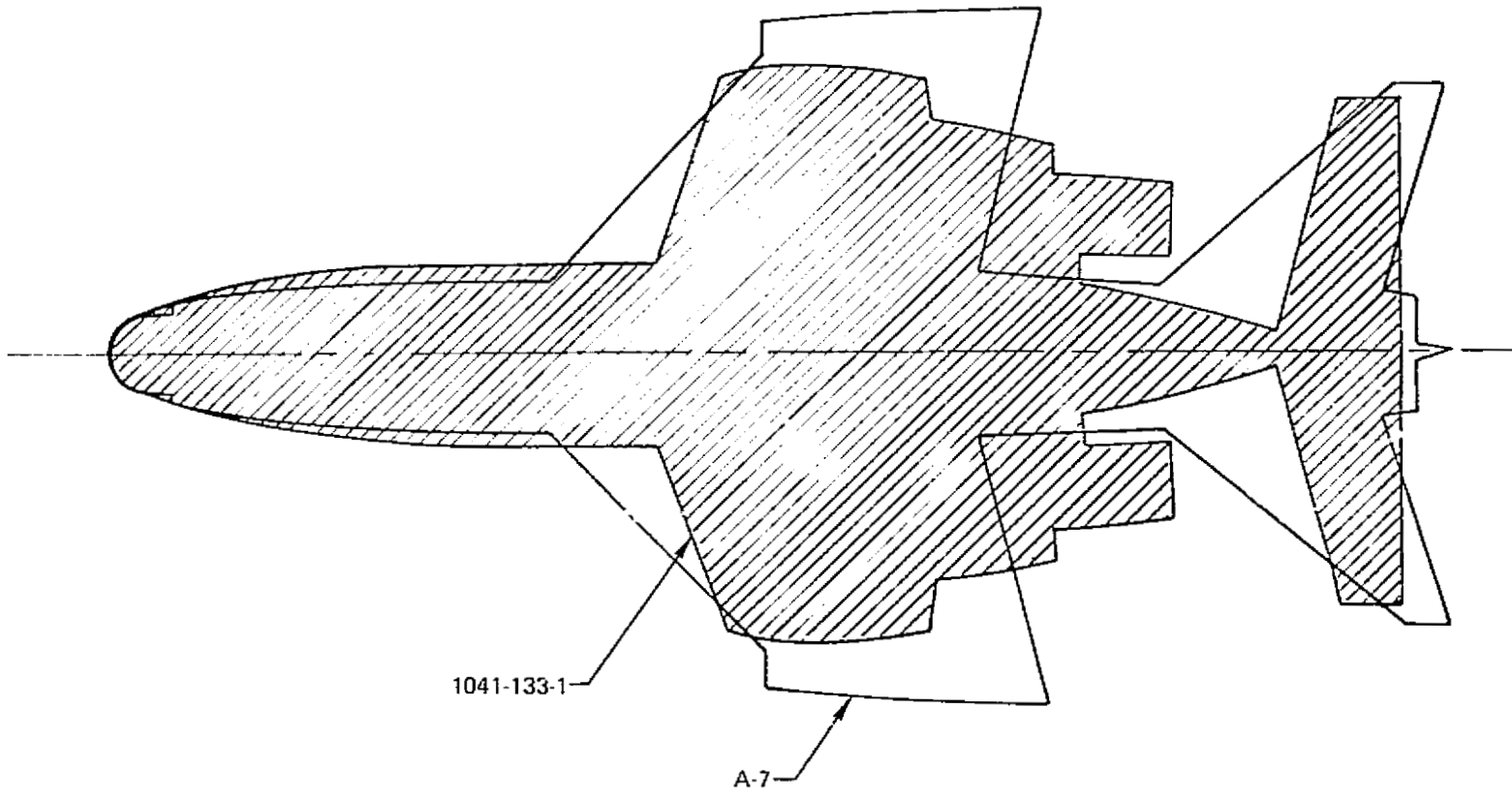

Figure 3.3.1-2.-Spotting Comparison



### 3.3.2 Internal Arrangement (1041-133-1)

The interior arrangement of the airplane is shown by Figure 3.3.2-1.

A four man crew cab is provided. Each crew station is equipped with a zero-zero ejection seat. A high visibility full bubble canopy is provided for the pilot and co-pilot with nearly straight down visibility over the side. Large transparent areas in the hatches for the two aft stations provide maximum use of visual observation.

Avionics is located in the nose forward of the nose fan. Access is from the bottom through a large hatch. The volume of this compartment not including the radome is 46 cu. ft. Fuel is located in the wing inboard of the fold and in four body tanks. The main body tank is located above the wing box and occupies the entire bay between the front and rear spar bulkheads. A forward body tank is located just forward of the front spar and below the aft crew stations. Two aft body tanks are located aft of the rear spar on either side of the sonobuoy bay. The total internal fuel capacity is 11,400 lbs.

Avionics systems are based upon the ASW Payload Summary from the Medium VTOL Systems Analysis Study as suggested in Attachment II of the contract work statement. No mission scenario analyses or avionic requirements analyses were conducted by The Boeing Company for this study. It is assumed that this avionics suite, weights, and elements are consistent with a 1985 ASW application.

The 50 sonobuoy capacity bay is located on the body centerline aft of the wing carry through box. A retractable mad boom is located in the body tail cone just aft of the sonobuoys.

The airplane accessory power components, two AC generators, twin hydraulic pumps and cabin pressurization and cooling compressor occupy the volume aft of the sonobuoy bay and below the fan drive "T" box.

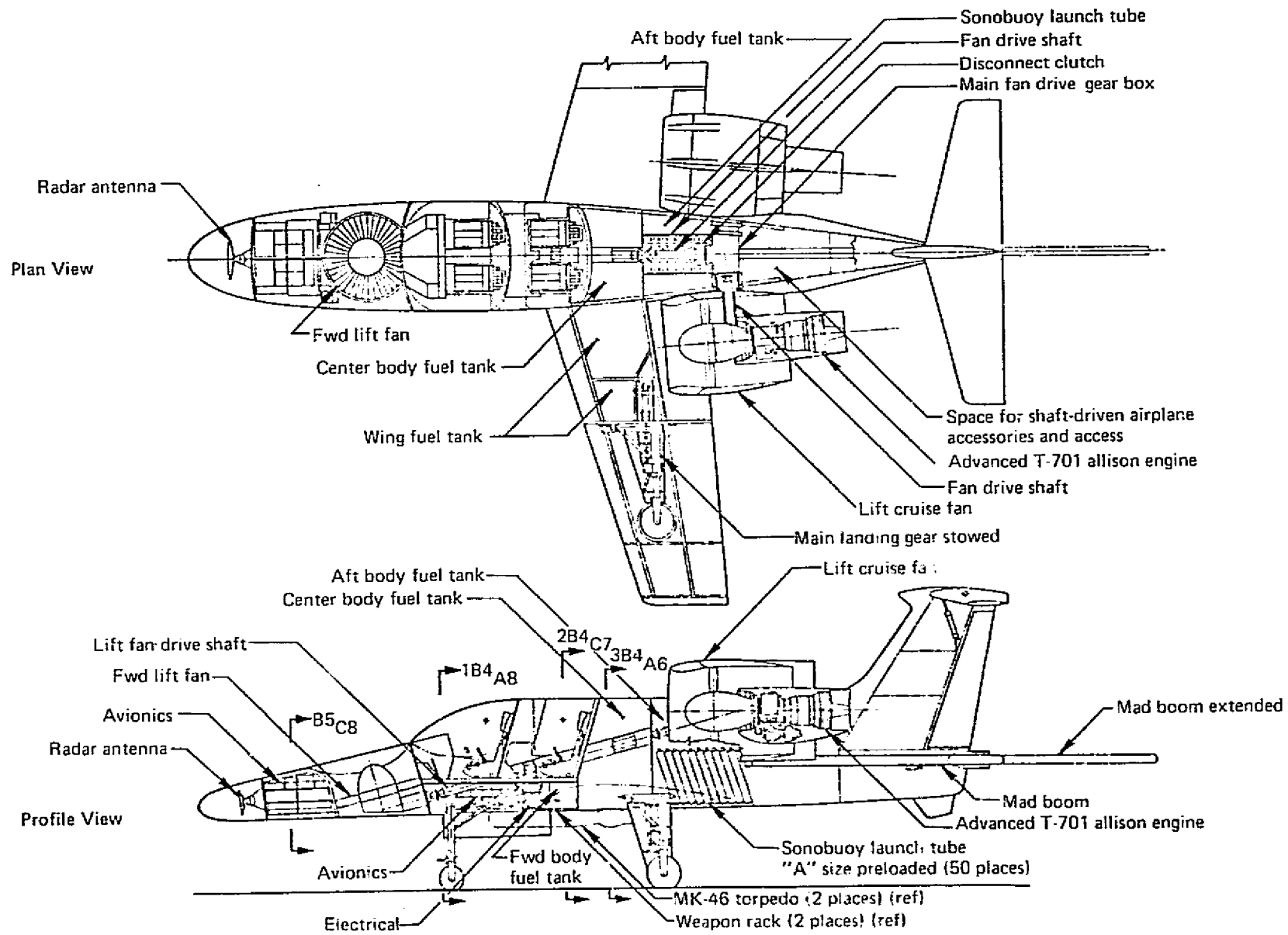

Figure 3.3.2-1.-Inboard Profile of Model 1041-133-1 ASW Airplane

Figure 3.3.2-2 shows the distribution of body volume. The gross volume includes the nacelle/body fairings. The principal contents of the body and the volume for each (installed) is indicated. Avionics volume does not include controls and displays in the cockpits; that volume is included in the cockpit volume. The avionics volume ( $46 \text{ ft}^3$ ) is obtained by applying a density of  $35 \text{ lbs/ft}^3$  to a weight of 1600 lbs. Drive system volume includes all shafts and gear boxes in the body and airplane accessories, i.e., generators and hydraulic pumps. The remaining electrical and hydraulic/pneumatic system are assumed to have densities of 50 and  $25 \text{ lbs/ft}^3$  respectively. The other volumes were obtained by measurement.

Table 3.3.2-1 itemizes the body volume and contents, as installed. The total required volume is about 2/3 of the total body volume available. Growth or a reduction in body volume are possible. The overall density of the body and contents is  $23 \text{ lbs/ft}^3$ .

A "straight through" drive shaft connects the nose fan to the "T" box. The shaft passes through a tunnel in the lower part of the aft crew station. An alternate arrangement using an additional gearbox is shown by Figure 3.3.2-3. This arrangement would reduce intrusion into the cabin at the price of the weight and complexity of the additional gearbox. The shaft elements are identical for both arrangements.

### 3.3.3 Aerodynamic Characteristics (1041-133-1)

#### 3.3.3.1 Lift and Drag Data

The basic 1041-133 (ASW) aerodynamic characteristics are presented in Table 3.3.3-1 and Figs. 3.3.3-1 to -8. Table 3.3.3-1 is a detailed breakdown of lift independent drag. Polar shape (Figure 3.3.3-2) results in an (L/D) maximum of 11.9. Trimmed oswald efficiency at the loiter condition is shown in Figure 3.3.3-3 as 0.87.

Buffet onset lift coefficient is presented in Figure 3.3.3-4. The curve is based on YC-14 RMS root bending divergence, for Mach numbers in excess of 0.50, and on break in linearity of the lift curve at lower speeds. Maximum usable lift coefficient is felt to be beyond the scope of the current analysis and will require testing.

Table 3.3.2-1.—Body Volume Buildup, Model 1041-133-1

<u>Item</u>	<u>Volume, Ft<sup>3</sup></u>
Forward Cockpit	143
Aft Cockpit	104
Avionics	46
Radome	25
Nose Fan	69
Nose Landing Gear	9
Drive System	30
Hydraulic/Pneumatic System	12
Electrical System	13
Sonobuoys	33
Mad Boom	5
Torpedo Racks	1
Air Conditioning Pack	15
Oxygen System	3
Fuel	161
Structure	17
Unused	334
TOTAL	1020

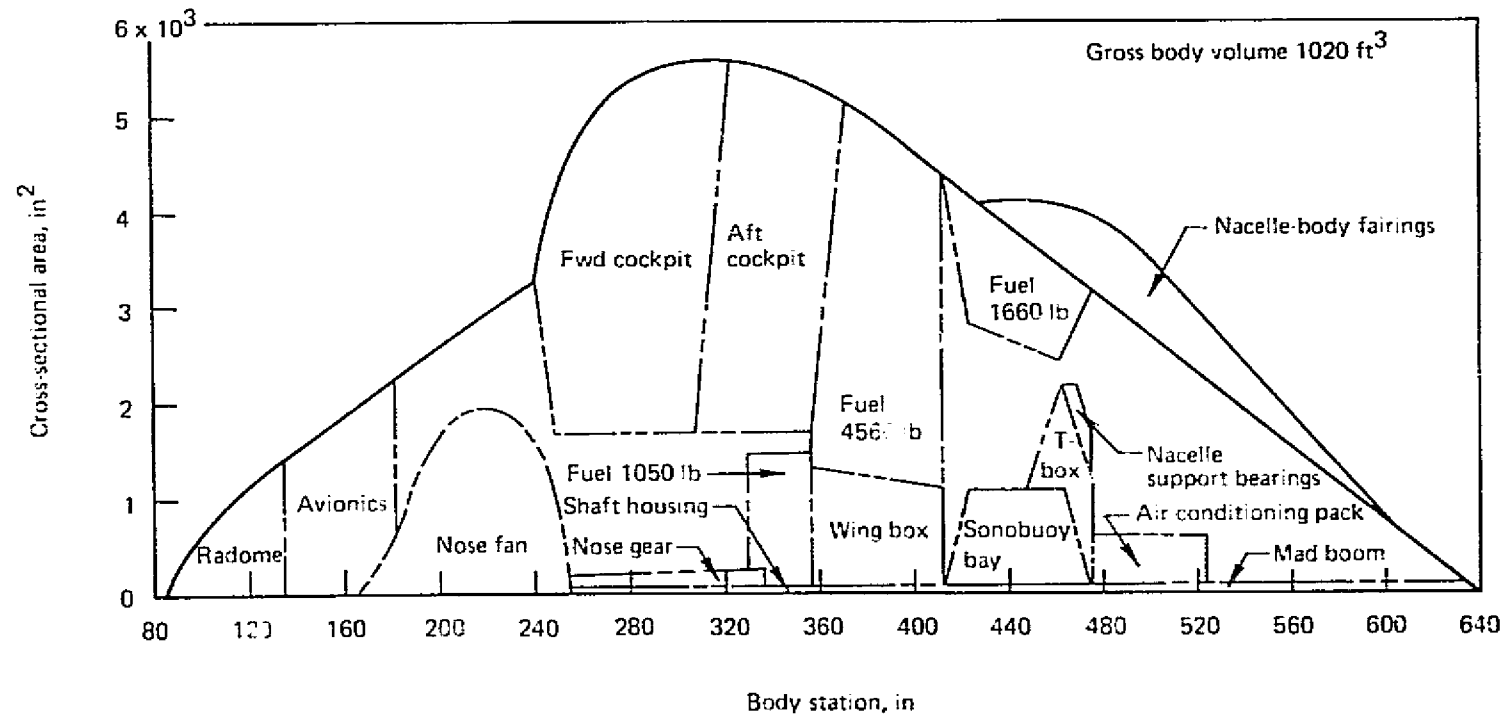
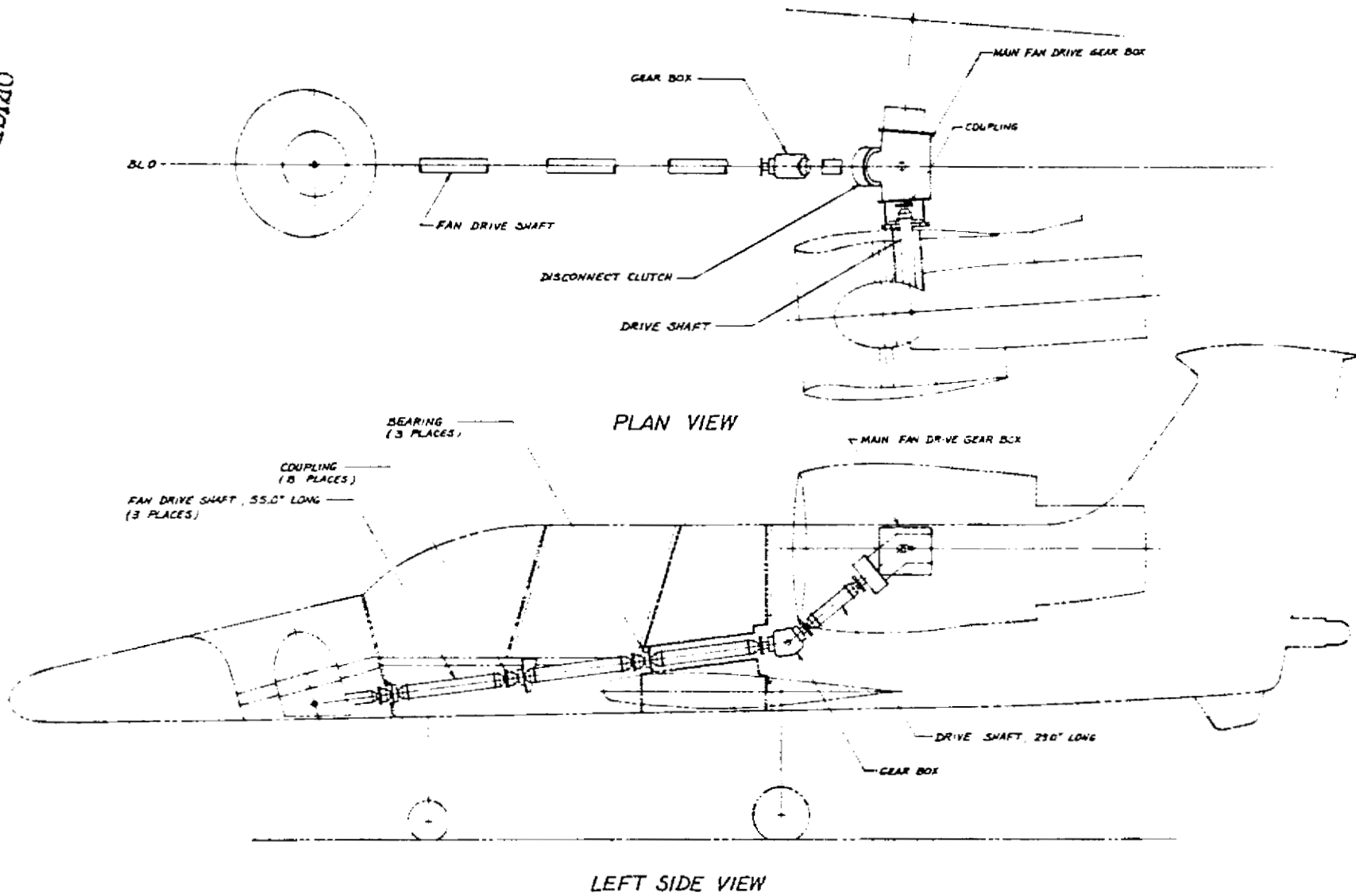

Figure 3.3.2-2.—Area Distribution, Model 1041-133-1

ORIGINAL PAGE IS  
OF POOR QUALITY



65

Figure 3.3.2-3.—Alternate Fan Drive System, Model 1041-133-1 (ASW Airplane)

Table 3.3.3-1.-Drag Summary Nonlift Dependent

LCFA 1041 - 133 (ASW)

M = 0.5  
 $S_{ref} = 310 \text{ FT}^2$

<u>SKIN FRICTION</u>	
WING	.00439
BODY	.00524
VERTICAL TAIL	.00058
HORIZ. TAIL	.00134
<u>NACELLES</u>	<u>.00216</u>
SUB TOTAL	.01371
<u>FORM DRAG</u>	
WING	.00166
BODY	.00066
VERTICAL TAIL	.00014
HORIZ. TAIL	.00048
<u>NACELLES</u>	<u>.00014</u>
SUB TOTAL	.00308
<u>INTERFERENCE DRAG</u>	
WING-BODY	.00035
HORIZ.-VERTICAL	.00005
<u>NACELLE BODY</u>	<u>.00327</u>
SUB TOTAL	.00367
<u>EXCRESCENCE DRAG</u>	.00327
<u>MISCELLANEOUS</u>	
CANOPY	.00078
TAIL SKID	.00005
MAD BOOM	.00050
FRONT FAN LOUVER DOORS	.00009
SONOBUOY ROUGHNESS	.00088
TORPEDOES (2)	.00220
AIR DATA PROBE	.00011
UHF/IFF ANTENNAS (2)	.00005
FUEL TANK VENTS (4)	.00001
<u>BEACON (1)</u>	<u>.00001</u>
SUB TOTAL	.00468
TOTAL	.02841

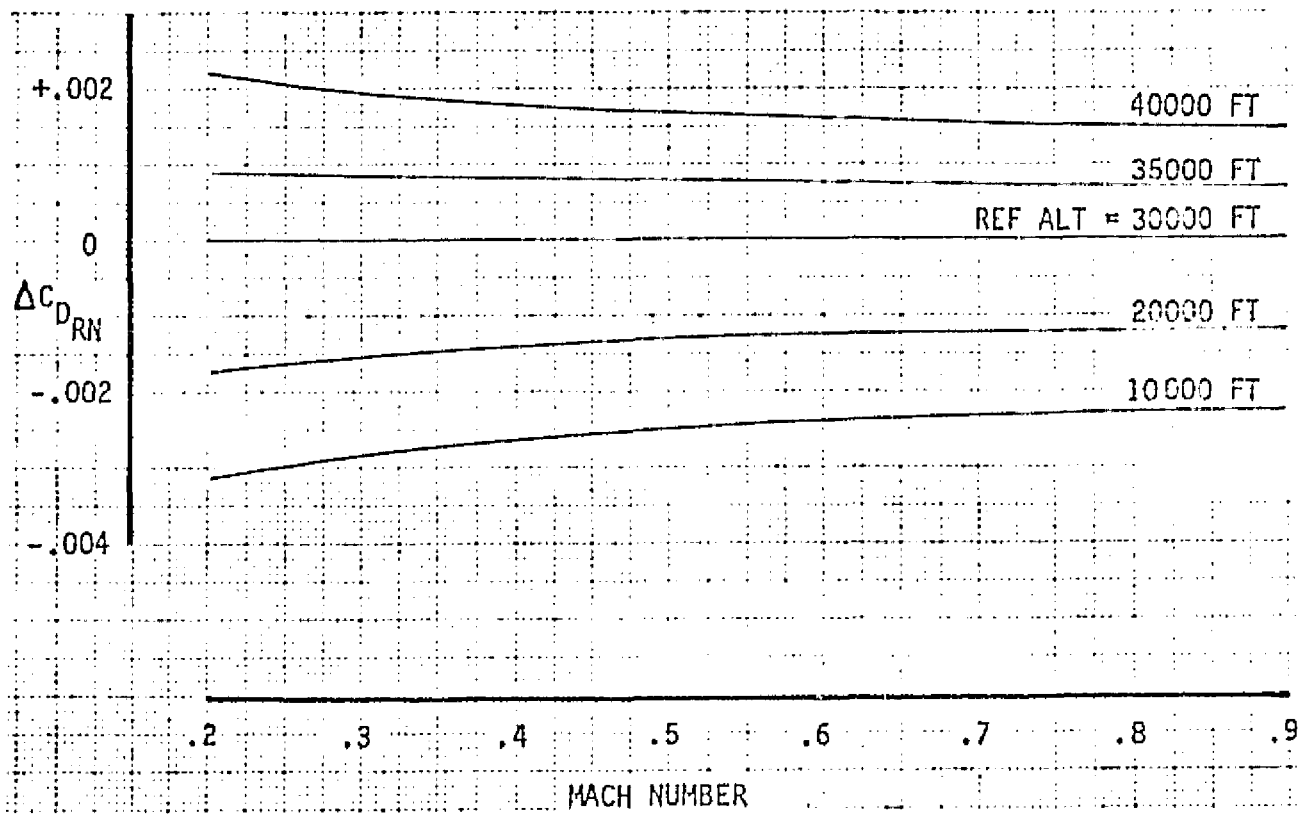

Figure 3.3.3-1.—Reynolds Number Skin Friction Correction 1041-133-1 (ASW)



$S_{REF} = 310 \text{ FT}^2$

- SKIN FRICTION (REF = 30,000 FT)
- ROUGHNESS + EXCRESCENCE
- AFTERBODY DRAG
- EXTERNAL STORES

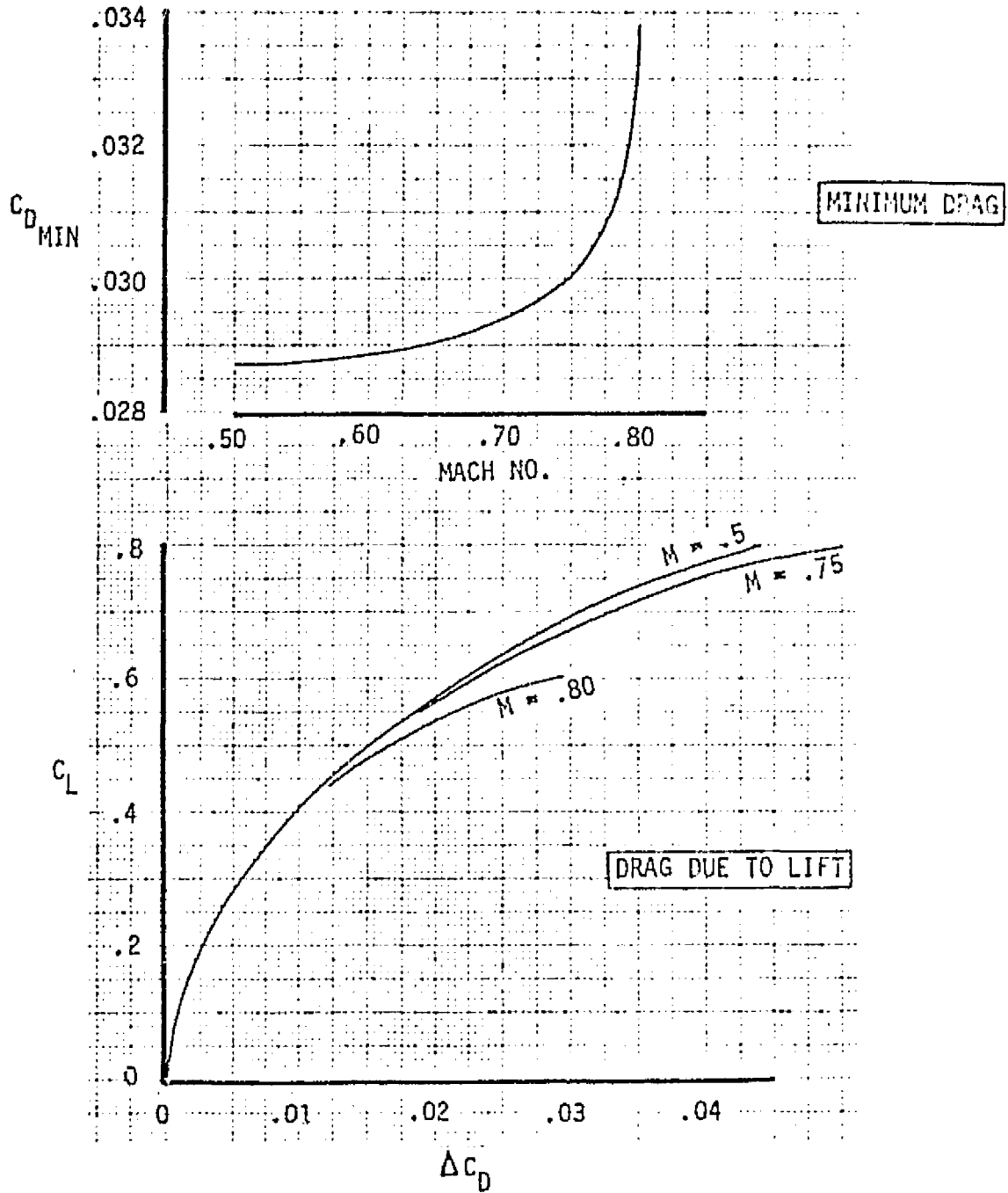
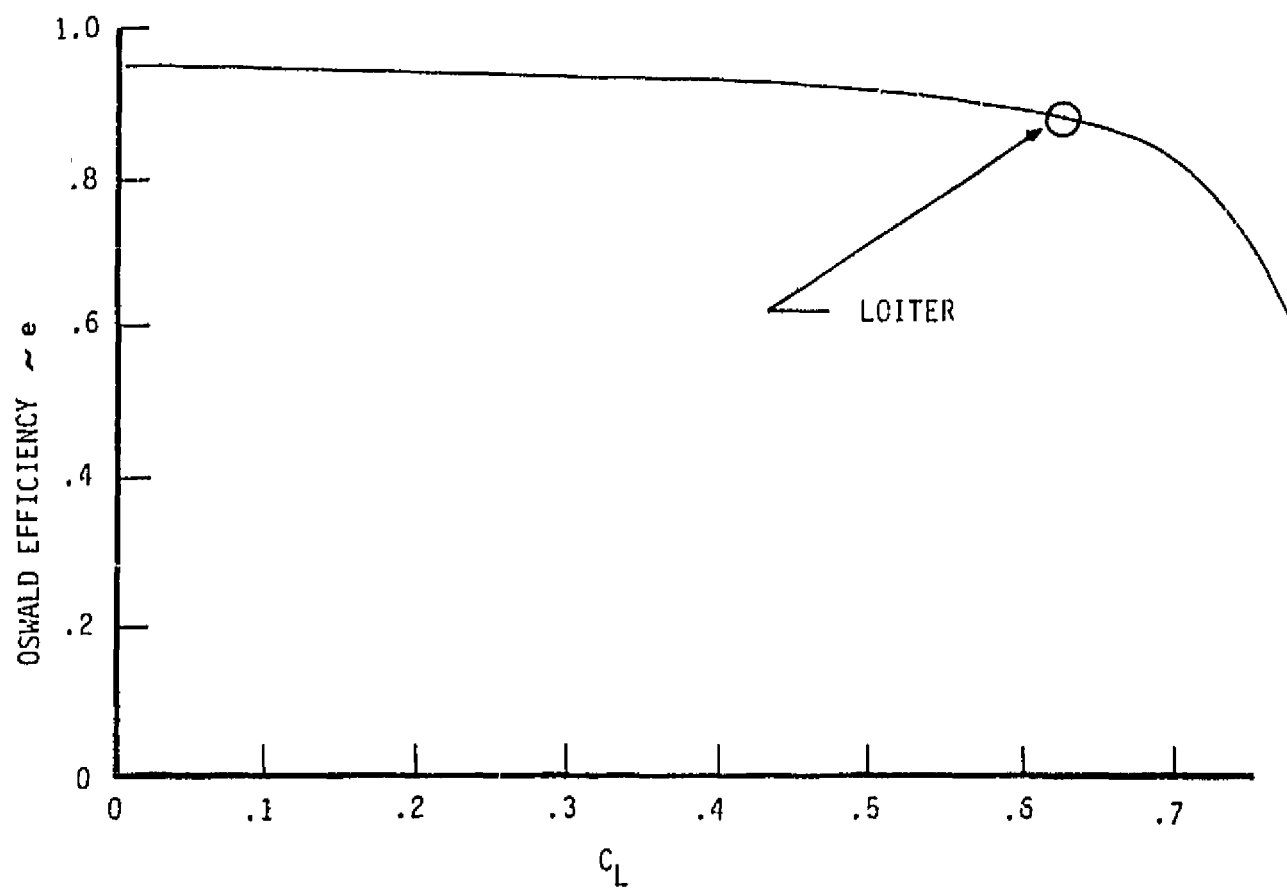

Figure 3.3.3-2.-Drag Breakdown 1041-133-1 (ASW)

ASPECT RATIO = 5.5  
 $k = .50$   
 TRIMMED ( $C_g = .35c$ )



$$C_D = C_{D\text{MIN}} + \Delta C_{D\text{CAMBER}} + \frac{C_L^2}{\pi A e}$$

ZERO CAMBER

Figure 3.3.3-3.—Oswald Efficiency Factor LCFA 1041-133 (ASW)

$$S_{REF} = 310 \text{ FT}^2$$

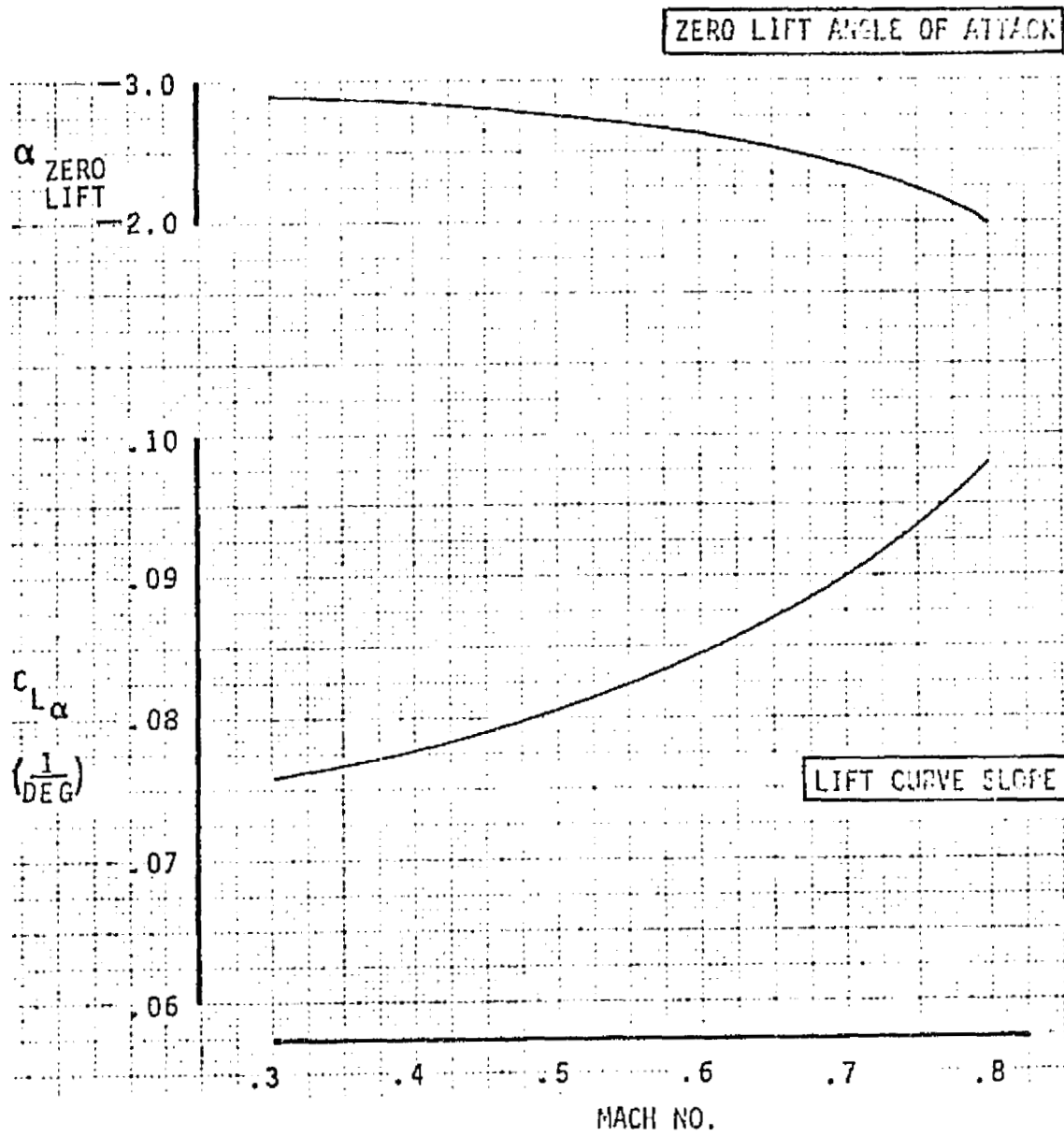

Figure 3.3.3-5.-Lift Characteristics 1041-133-1 (ASW)

PRECEDING PAGE BLANK NOT FILMED

$$S_{REF} = 310 \text{ FT}^2$$

TWO MARK 46 TORPEDOES  
FUSELAGE TANGENT MOUNT

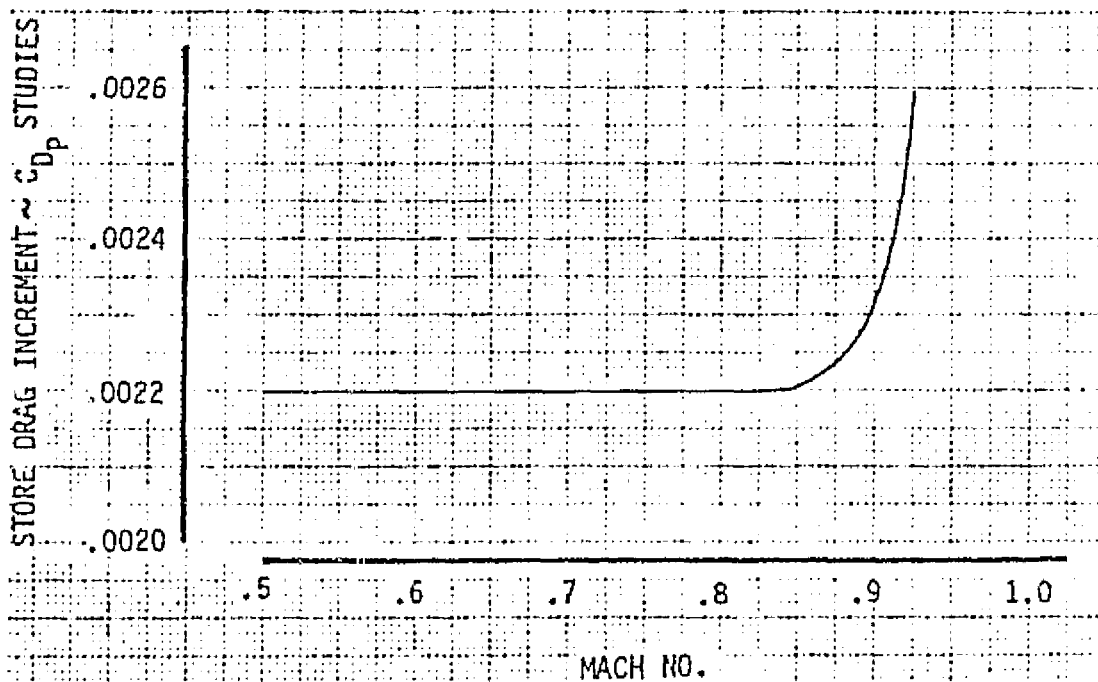

Figure 3.3.3-6.—External Store Drag 1041-133-1 (ASW)

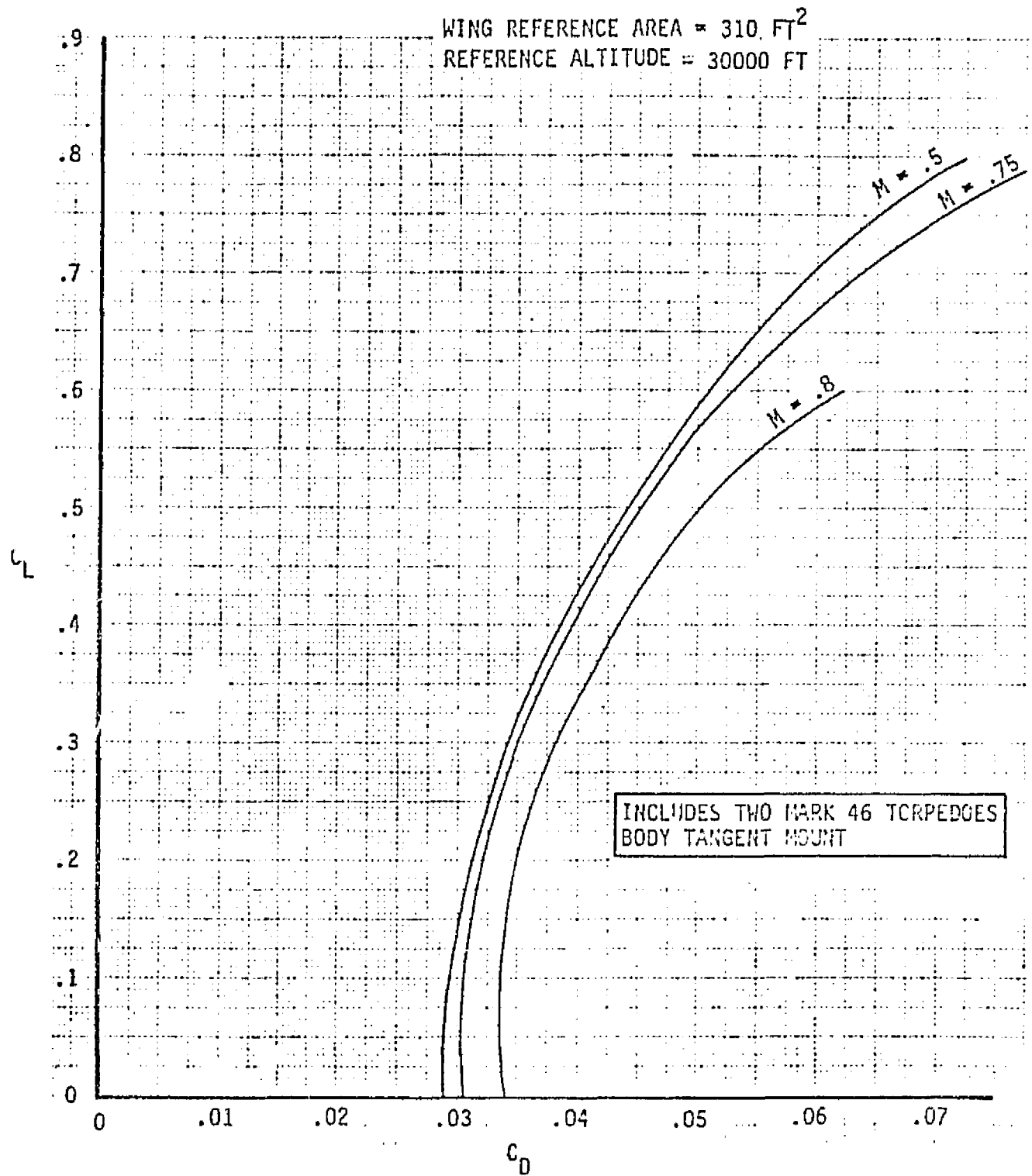

Figure 3.3.3-7.—Trimmed Drag Polar 1041-133-1 (ASW)

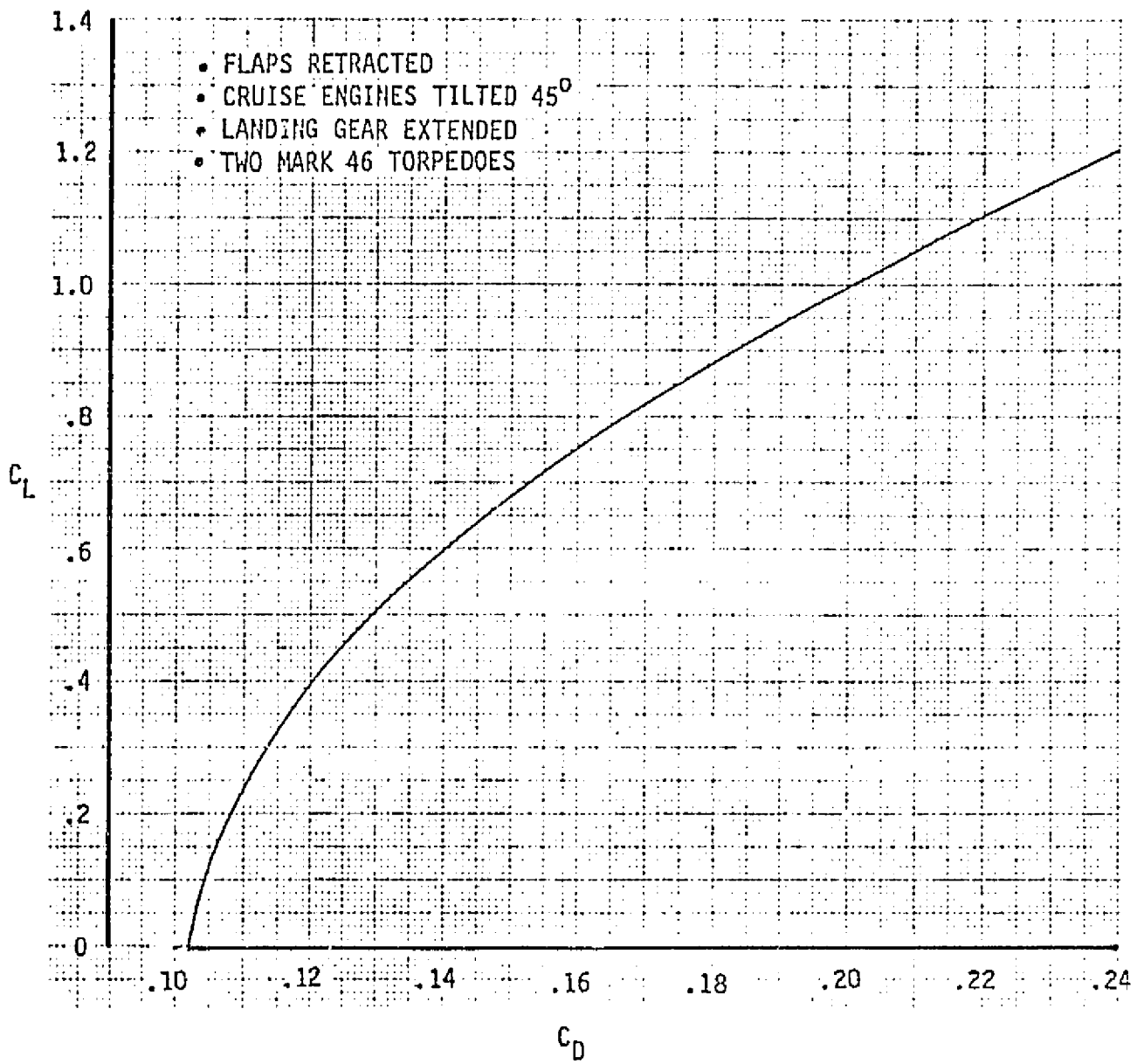

Figure 3.3.3-8.-V/STOL Configuration Polar 1041-133-1 (ASW) Out of Ground Effect

The remaining characteristics; lift curve slope, zero lift angle of attack and store drag are shown in Figures 3.3.3-5 through 3.3.3-6.

Trimmed polars for the cruise and STO configurations, out of ground effect, are presented in Figures 3.3.3-7 and 3.3.3-8 respectively. Ground effects, for configurations where the thrust is deflected similar to the -133-1 (ASW), are highly configuration dependent and are best obtained by test. Since STO liftoff speeds are so low the performance impact of neglecting ground effects will be small and have been assumed so. It should be noted that no credit has been taken for beneficial induced lift due to jet induced downwash at the wing trailing edge.

VTOL ground effect has been estimated as being neutral to favorable and will require test verification. See Appendix C for further discussion.

### 3.3.3.2 Performance, Model 1041-133-1 ASW

The ASW airplane mission requirement calls for a 400 foot takeoff in a 10 knot wind; cruise 150 n.m., then four hours loiter at 10,000 feet and return to base.

The shortest takeoff can be achieved by rotating the nacelles toward vertical just at lift off; however, this airplane can meet the required goals without nacelle rotation, thus providing operational simplicity. The time history of a takeoff in which the engine tilt angle is held fixed at  $\lambda = 50^\circ$  shown in Figure 3.3.3-9. During acceleration the nose fan is engaged, but is set at flat pitch in order to get maximum thrust from the lift/cruise fans. Rotation is initiated 5.5 sec. after brake release at a speed of 92 ft/sec. At 7.75 sec. the airplane has rotated to  $\alpha = 8^\circ$  and liftoff occurs at an airspeed of 115 ft/sec. The liftoff lift coefficient of 1.6 used in this calculation is conservative in that no credit has been taken for induced aerodynamic effects. The takeoff run is 400 foot and the longitudinal acceleration at liftoff is .103 g's; this exceeds the requirement of .065 g's. The capability of making an emergency vertical landing with one engine out at a maximum sink speed of 15 ft/sec is assumed to be met if the thrust and weight are equal. This requirement is exceeded by the Model 1041-133 which has an emergency landing weight of 24,500 lbs. and engine out contingency thrust of 25,300 lbs.

Sea level, 90° F std day  
 $\lambda$  = constant = 50°  
 $C_{L_{LO}}$  = 1.6 (flap plus drooped ailerons)  
 $(F/W)_{static}$  = 0.7  $(F/W)_{lift-off}$  = 0.9  
 $a_{LO}$  = 3.33 fps<sup>2</sup> (longitudinal)

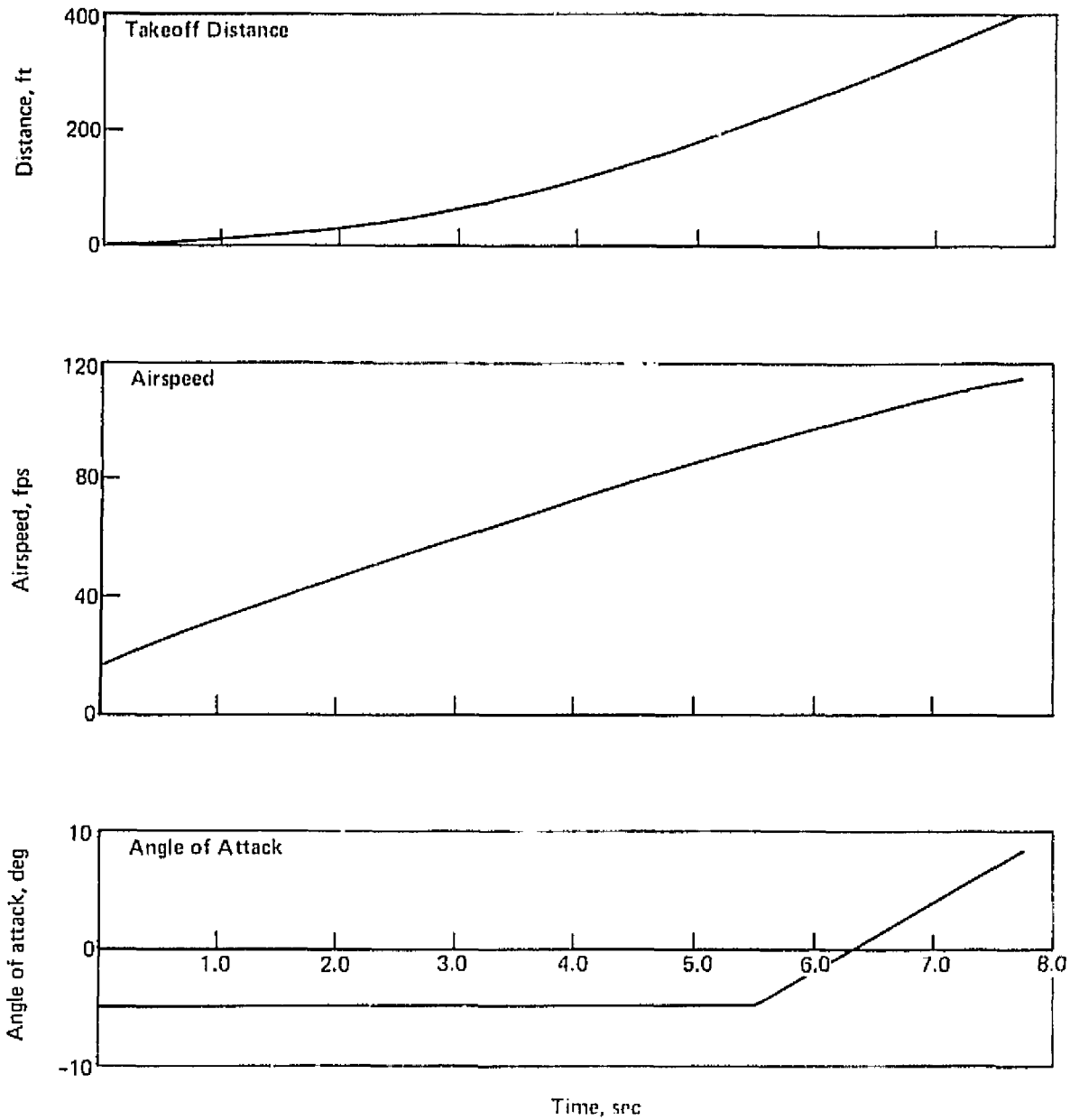

Figure 3.3.3-9.—STO Time History, 1041-133-1 (ASW)



STO Mission - The ASW mission requirement calls for a 150-mile radius with 4 hours of loiter on station at 10000 ft. Figure 3.3.3-10 presents the breakdown of the calculation of this mission in terms of speed, time, distance and fuel burned for each mission segment. The airplane, sized to meet this mission, has a takeoff weight of 38,394 lbs. Initial cruise altitude is 33,000 ft. at  $M = 0.75$ . The 4 hour loiter at 10000 ft. is performed at  $M = 0.42$ . The total fuel required for the mission is 11,914 lbs. including landing allowance, reserves and a 5% service tolerance on SFC throughout the mission.

VTO Mission - Although water/alcohol augmentation is not at this time, included in the PD370-15 performance, the potential of such an addition was examined. The addition of water/alcohol will substantially increase the vertical takeoff capability and provide a useful VTO mission. Figure 3.3.3-11 presents a breakdown for this mission. The loiter time is 3.16 hours. The F/W at takeoff is 1.05. The thrust is 33,700 lbs., and mission weight is thus restricted to 36,857 lbs. The configuration requires 390 lbs. of alcohol-water and 110 lbs. of tank and plumbing.

The relationship between radius and time on station is linear. The maximum mission radius with no loiter time is about 900 n.mi. from a short takeoff. For a vertical takeoff the mission radius with no loiter is 720 miles.

#### Performance Flight Envelope

Figure 3.3.3-12 presents the cruise configuration level flight performance envelope for standard day conditions at an airplane weight of 36,000 lbs. At this weight the airplane is capable of operation up to 40,000 ft. altitude, where it is buffet limited. The maximum Mach number, which is also buffet limited, exceeds .8 at all altitudes below 35,000 feet to the altitude where the  $q$  limit occurs.

On the same figure the V/STOL flight mode envelope at about 26,000 pounds is shown. The overlap between the two modes assures a good transition corridor.

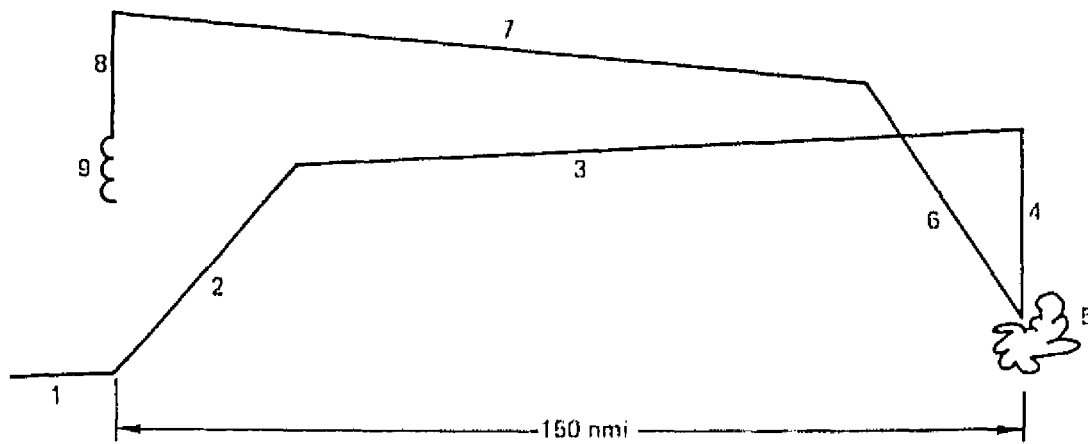

Segment	Speed	Time, hr	Distance nmi	Fuel* lb	A/P weight, lb start of segment
1. Warmup, takeoff, accel to climb speed	--	0.047	--	331	38 394
2. Climb to BCAV	320 CAS kn	0.063	33	624	38 063
3. Cruise at BCAV (initial altitude = 33 000 ft)	M = 0.75	0.268	117	646	37 439
4. Descend to 10 000 ft	--	--	--	--	36 793
5. Loiter at 10 000 ft	M = 0.42	4.000	--	8530	36 793
6. Climb to BCAV	M = 0.75	0.054	24	337	28 263
7. Cruise at BCAV (initial altitude = 39 000 ft)	M = 0.75	0.293	126	529	27 926
8. Descend to sea level	--	--	--	--	27 397
9. Landing allowance and reserve					
● Loiter at sea level 10 min	M = 0.31	0.167	--	350	27 397
● Total initial fuel 5%	--	--	--	567	27 047
OEW + payload					26 480†

\*5% service tolerance added throughout.

†Includes 100 lb external tanks.

Figure 3.3.3-10.--STO Mission Breakdown LCFA-1041-133 (ASW)

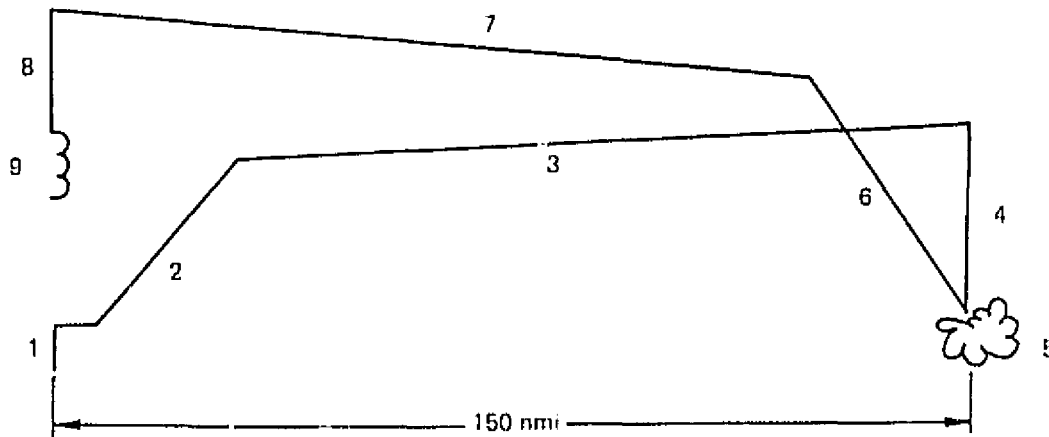

Segment	Speed	Time, hr	Distance, nmi	Fuel,* lb	A/P weight, lb start of segment
1. Warmup, VTO, conversion, accel to climb speed	--	0.042	--	826	36 857
2. Climb to BCAV	320 CAS kn	0.080	32	602	36 031
3. Cruise at BCAV (initial altitude ≈ 33 000 ft)	M = 0.75	0.271	118	660	35 429
4. Descend to 10 000 ft	--	--	--	--	34 769
5. Loiter at 10 000 ft	M = 0.42	3.16	--	6578	34 769
6. Climb to BCAV	M = 0.75	0.054	24	337	28 191
7. Cruise at BCAV (initial altitude ≈ 38 000 ft)	M = 0.75	0.293	126	561	27 854
8. Descend to sea level	--	--	--	--	27 293
9. Landing allowance and reserve					
● Loiter at sea level 10 min	M = 0.31	0.167	--	381	27 293
● Total initial fuel 5%	--	--	--	482	26 912
OEW + payload					26 430†

\*5% service tolerance added throughout.

†Includes 440 lb of Alcohol/H<sub>2</sub>O.

Figure 3.3.3-11.--VTO Mission Breakdown LCFA 1941-133-1 (ASW)

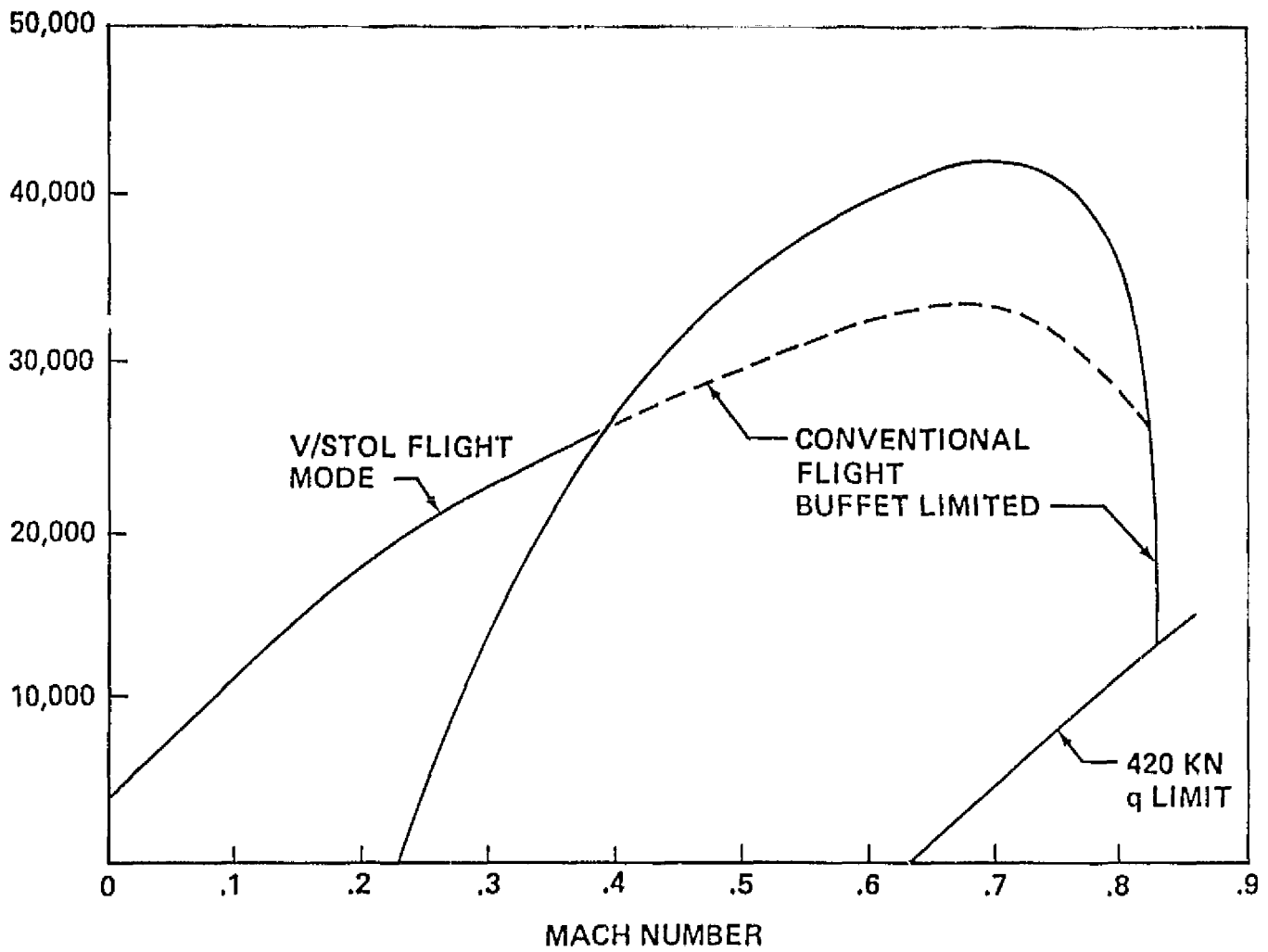

Figure 3.3.3-12.-Model 1041-133 Flight Envelope

### Load Factors

Maximum aerodynamic load factors are presented in Table 3.3.3-2, at sea level ( $M = 0.3$ ) and 10,000 ft. ( $M = .65$  and  $.835$ ). Test data is required for an accurate assessment of maximum usable lift; the values used are based on YC-14 values. Maximum sustained load factor is based on intermediate thrust. At the combat condition ( $M = .65$  at 10,000 ft.) the load factors exceed 3.38.

#### 3.3.4. Structural Criteria and Design (1041-133-1)

The flight speed altitude envelope is shown on Figure 3.3.4-1. The level flight maximum speed ( $V_H$ ) is selected to meet the operational requirements for the ASW, surveillance and surface attack missions. It is below the maximum speed attainable in level flight. Appropriate restrictions to the maximum usable power in conventional flight will be imposed. AT a flight design weight of 33,130 lbs. a limit positive maneuvering load factor of 3 g's is required. V-n diagrams for sea level and 20,000 feet are shown on Figure 3.3.4-2.

The load stroke requirements for the main landing gear, 40,300 lbs. and 20 in. are based on a sink rate of 15 ft/sec at the design landing weight of 32,700 lb. The maximum design weight is the STO gross weight which is 38,390 lbs.

Advanced structural materials were selected based on the results of the Advanced Transport Technology Study, NASA Report CR-112092. Full depth graphite epoxy honeycomb was selected for the empennage surfaces and engine fan cowls. Stiffened graphite epoxy and graphite epoxy honeycomb were selected for the wing surfaces and body shell respectively. The all flying stabilizer attachment to the fin and the wing hinge are of metal construction. This structural concept is conservatively estimated to result in a weight reduction, compared to conventional metal structure of 10%.

Table 3.3.3-2.-Combat Load Factors W 33,810 lb

Condition	$\eta_{\text{max. sust}}$	$\eta_{\text{max. usable}}$	$\eta_{\text{buffet onset}}$
M = 0.3 at S.L.	1.52	1.56	1.42
M = 0.65 at 10K'	3.41	3.74	3.38
M = 0.835 at 10K'	1.00	3.15	2.06

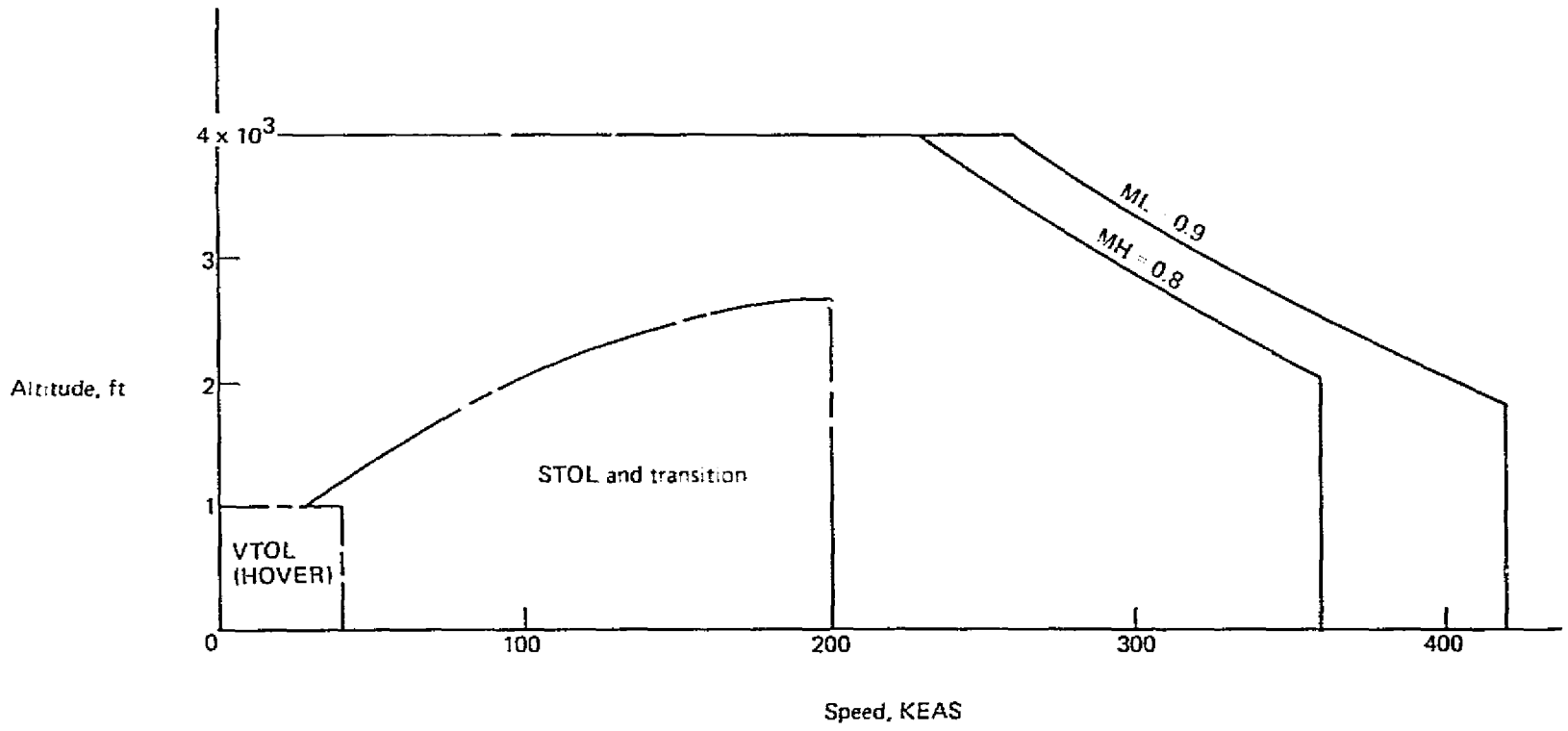

Figure 3.3.4-1.-Structural Speed-Altitude Envelope

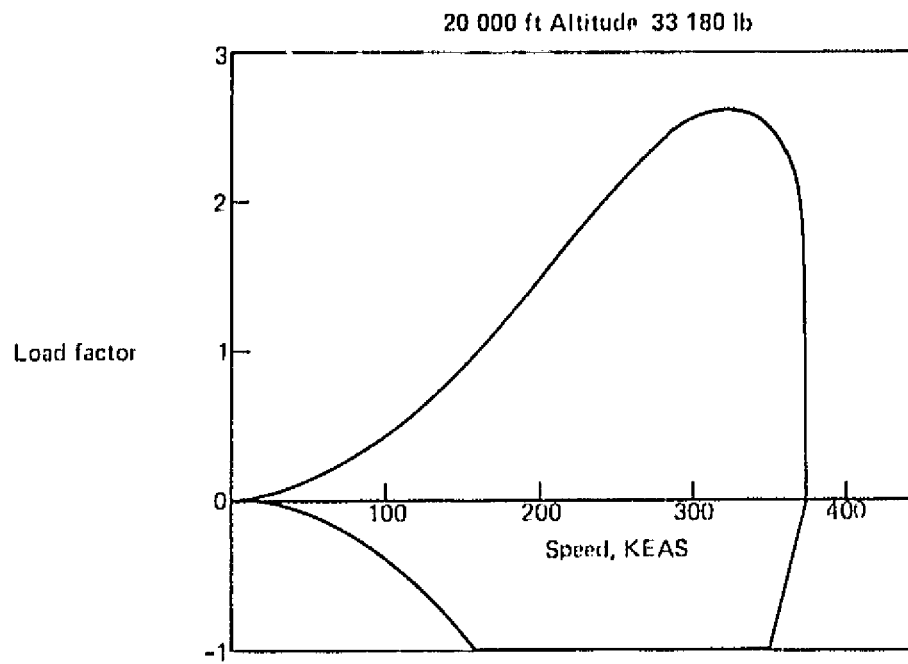
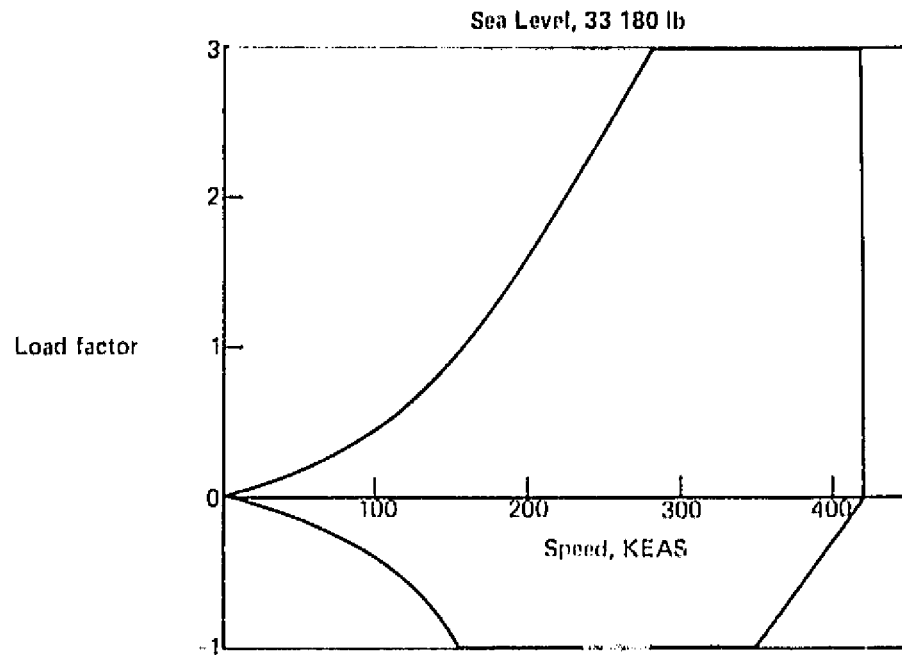

Figure 3.3.4-2.-V-n Diagrams



An important structural design detail for this airplane is the nacelle pivot support. Several concepts have been considered. The selected one is shown on Figure 3.3.4-3.

Fly-by-wire fan pitch and throttle controls and fuel supply are introduced to the pivot structure as shown schematically in Figure 3.3.4-4. It is of interest that once attachment is made to the pivot beam the routing from that point to the engine or fan involves no relative motion between the nacelle, the pivot beam and the services involved. By selecting the midpoint of the 110 degree throw for attachment, the extra loop material and length change accommodation is minimized. Fuel line diameter is 1½ inches. Clearance is quite adequate between the drive shaft and the beam for service routing.

This short tubular beam dual bearing arrangement offers advantages in weight and redundancy. The short load paths and low required installation volume result in structural efficiency and low installed weight. The dual bearings assure the nacelle will be retained even if one of the bearings should fail. A section through the outer bearing is shown on Figure 3.3.4-5. The split outer race construction provides a dual structural capability.

### 3.3.5 Aircraft Systems

#### Accessory Power

The prime power source for the airplane accessories is the accessory drive gearbox located aft of and driven by the transmission tee box. The accessory drive gearbox will drive two 75 KVA integrated drive generators, two 25 gpm hydraulic pumps, one air compressor, one tachometer and a lube pump. Engine/airplane performance is based on the following accessory drive shaft power extraction:

<u>Condition</u>	<u>Shaft Horsepower Extraction</u>
Normal	200
Emergency	23
Cruise and Loiter	143
Design	450

C. 2

86

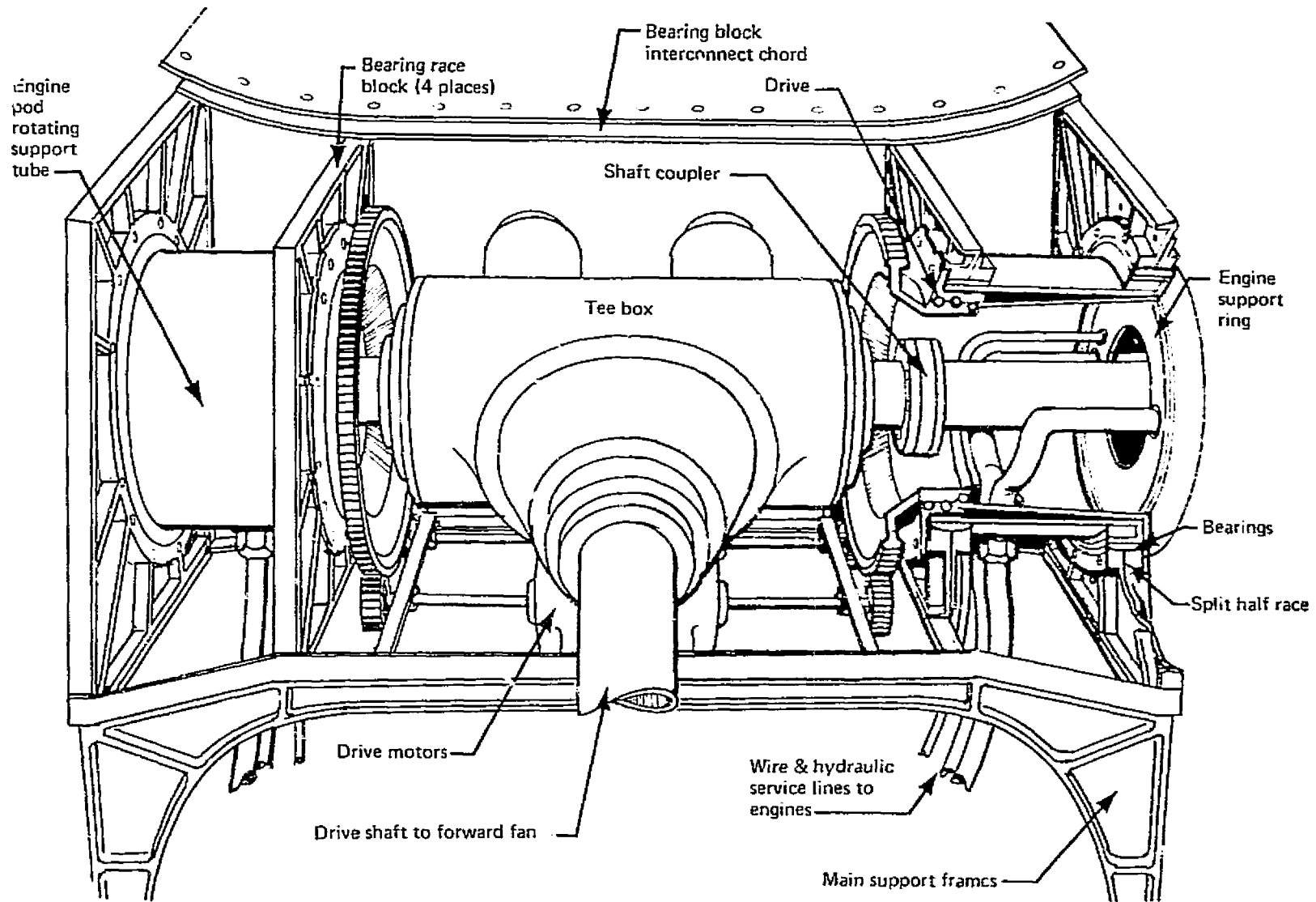

Figure 3.3.4-3.-General Structural Arrangement Engine Support and Rotation Mechanism

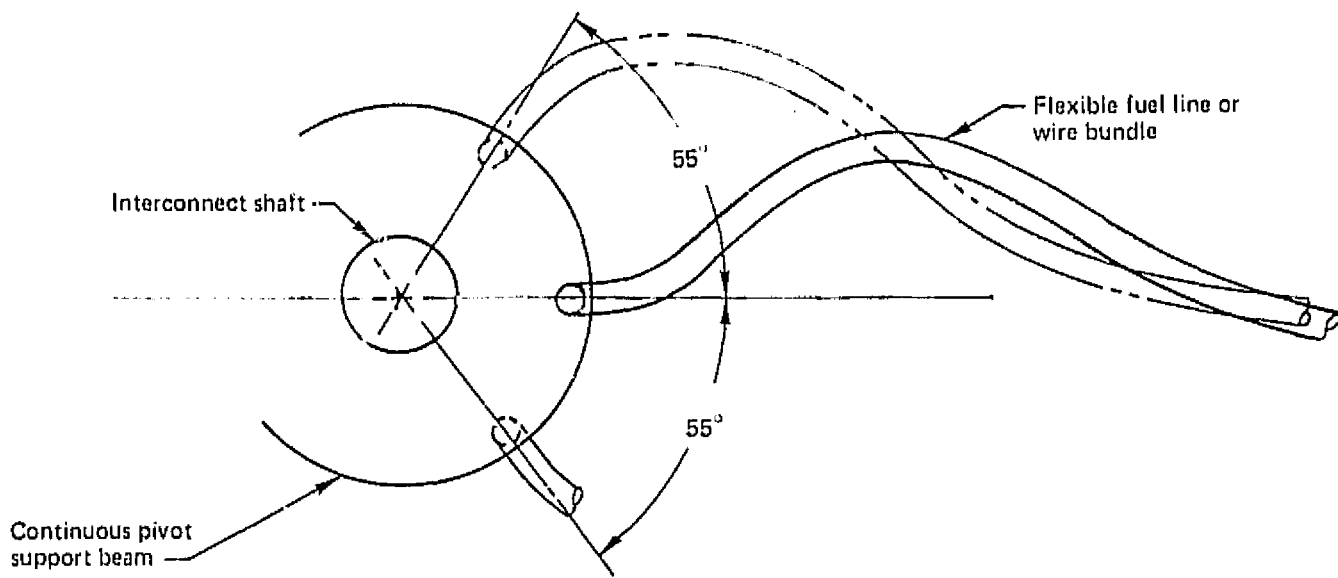

Figure 3.3.4-4.-Schematic of Services (Fuel, Electric, Bleed) to Pivot Beam

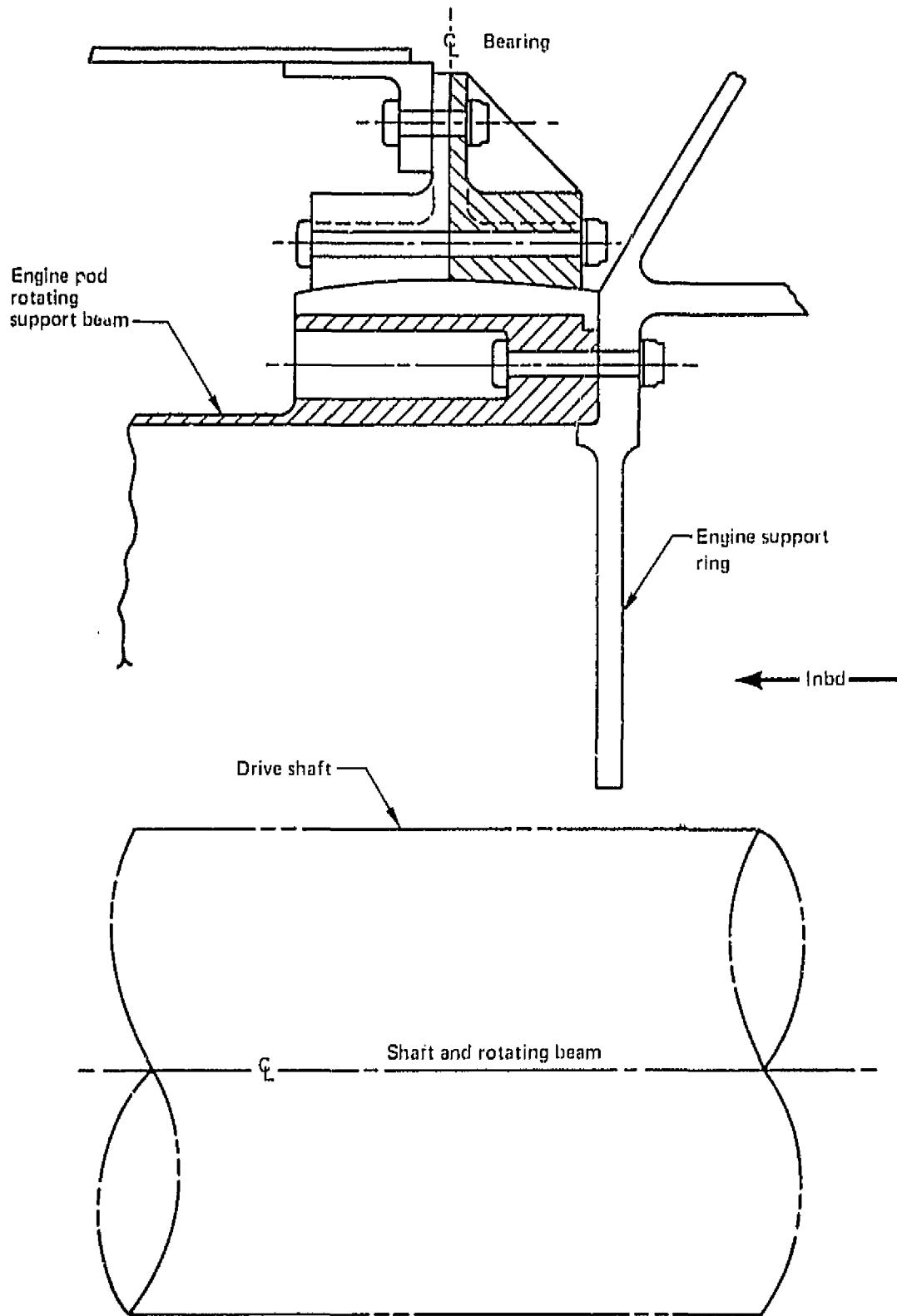

Figure 3.3.4-5.—Section Through Outer Bearing

Provisions included to reduce the total power extraction during emergency operation include electrical power reduction to essential power (4200 watts for electronics and control) and disconnect of the air compressor.

#### Electric Power

The electrical power supply consists of two 75 KVA integrated drive generators. This provides two separate power systems. A third backup power system is provided through the use of hydraulic/electric power conversion units. A battery is installed to provide essential power for emergency bus for ground checkout and initiation of engine start.

#### Hydraulic Power

Hydraulic power is provided by two 4000 psi hydraulic pumps of approximately 20 to 25 gpm each supplying an independent circuit for operation of the flight control and airplane utility systems. All fan blade angles and the exhaust deflection vanes of the cruise/lift fans are powered by the airplane hydraulic system.

#### Starting System

The starting system will provide for independent engine starting. In addition, the airplane weight allowances are sufficient to support the installation of a reliable inflight start system.

#### Environmental Control

Aircraft pressurization will be provided by an air compressor driven by the accessory drive. Cooling is provided by a conventional air turbine unit. Adequate airflow will be provided to meet cabin and electronic conditioning requirements and windshield defogging. Provisions are included to use ram air ventilation.

#### Protective Systems

The protective systems detailed requirements have not been established but allowances are carried in the weight statements. These include typically oxygen, rain removal, anti-icing, smoke clearance and escape systems.

### Mission System Provisions

The mission equipment provisions are as follows: Avionics are located in the nose forward of the nose fan and below the pilot's floor aft of the nose fan on either side of the nose wheel well. The retractable MAD boom is located aft of the sonobuoy compartment. A 50 sonobuoy capacity bay is located aft of the wing carry through box. The bay is tilted to ease loading and provide space for the flap drive. External body mounts include provisions for two MK-46 torpedos flush mounted just forward of the wing box on the lower body shoulders. Two wing attachment points are included for external fuel tanks.

### Fuel System

Fuel is located in the wing box inboard of the fold and in four body tanks. The main body tank is located above the wing box and occupies the entire bay between the front and rear spar bulkheads. A forward body tank is located just forward of the front spar and below the aft crew stations. Two body tanks are located aft of the rear spar on either side of the sonobuoy bay. The weight includes allowance for inflight refueling.

### Engine Bleed Air

Engine bleed air is not used on this airplane.

### 3.3.6 Propulsion (1041-133-1)

The engine operational requirements are defined by the airplane operational modes. The critical engine sizing conditions is that vertical thrust equals the weight during hover with one engine inoperable. The emergency weight has been defined as operating weight plus 1000 lbs. fuel.

The requirements placed on availability of the propulsion system were:

- o The engine had to be in service, in development, or a derivative of one in service or development.
- o The fan design was to have a firm technology base consistent with 10C 1985.

Complete performance of the propulsion system is in Appendix B.

#### Engine Availability

During initial propulsion system studies, a review of available candidate turboshaft engines was conducted. Initial engine selection studies and airplane preliminary design studies involved several iterations in matching engine power output with thrust required to achieve the V/STOL mission requirements.

Of the engines studied a growth version of the Allison T701 (PD370-15) and a turboshaft engine based on the G.E. F101 core were considered. The power size and weight of these engines are:

	Intermediate HP SLS 90°F	Weight LB	Length IN	Diameter IN
Allison PD 370-15	11,250	1,219	68.1	28.70
GE F101 (Modified)	13,000	1,700	45.1	31.2

The Allison T701 was developed in the HLH program. The T701 has successfully completed a PPFRT program and will be available for use in the technology demonstrator. The GE F101 core with modification to the low spool and turbine offers another source for the 1985 operational airplane. The current applications of the F101 core are for the B-1 bomber and with CFM56

commercial turbofan engine. Either of these engines in conjunction with a variable pitch fan satisfies the operational airplane requirements.

#### Model 1041-133-1 Integrated Propulsion System

The propulsion system used consists of: two Allison engines, three Hamilton-Standard 62 inch diameter variable pitch fans, with the associated gearing, shafting and clutches.

Schematically, the propulsion system is shown in Figure 1.0-2 with the major components identified. The two engines are mounted behind the two lift/cruise fans. A star gear train reduces the engine speed to the fan speed and a bevel set connects the engine/fan to a cross shaft which enters the combiner gearbox. An overrunning clutch will automatically disconnect the engine from the system if it fails, and the remaining engine can run all three fans. The airplane accessories are geared into the forward output shaft from the combiner gearbox. A disconnect clutch ahead of the accessories on the forward shaft allows the nose fan with its bevel reduction gear to be disconnected during the conventional flight conditions. Inlet doors open during operation of the nose fan and close during conventional flight. The undersurface doors of the nose fan become yaw control vanes during takeoff and landing.

A sketch of the tilting lift/cruise propulsion pod is shown on Figure 3.3.6.1. The engine receives airflow from the fan and the fan and engine exhaust from separate nozzles. The fan nozzle area is varied from wide open in vertical flight to about 70% of this area in cruise and loiter. The inlet is a high performance inlet contoured to have low cruise drag, with blow-in doors to achieve good low speed performance and acceptable distortions at incidence angles up to  $115^{\circ}$ . Fins at the fan exit provide yawing moments for the airplane control system. Airplane rolling moments and pitching moments are provided by varying the thrust of the variable pitch fans with redundant blade pitch control systems.

The propulsion system will provide adequate vertical thrust in normal and engine out conditions. Individual fan thrust can be rapidly increased or decreased to provide adequate pitch and roll control by varying fan blade pitch angle. The fans and engines are located the proper distances from the airplane C.G. to provide balanced lift with either fan in its design.



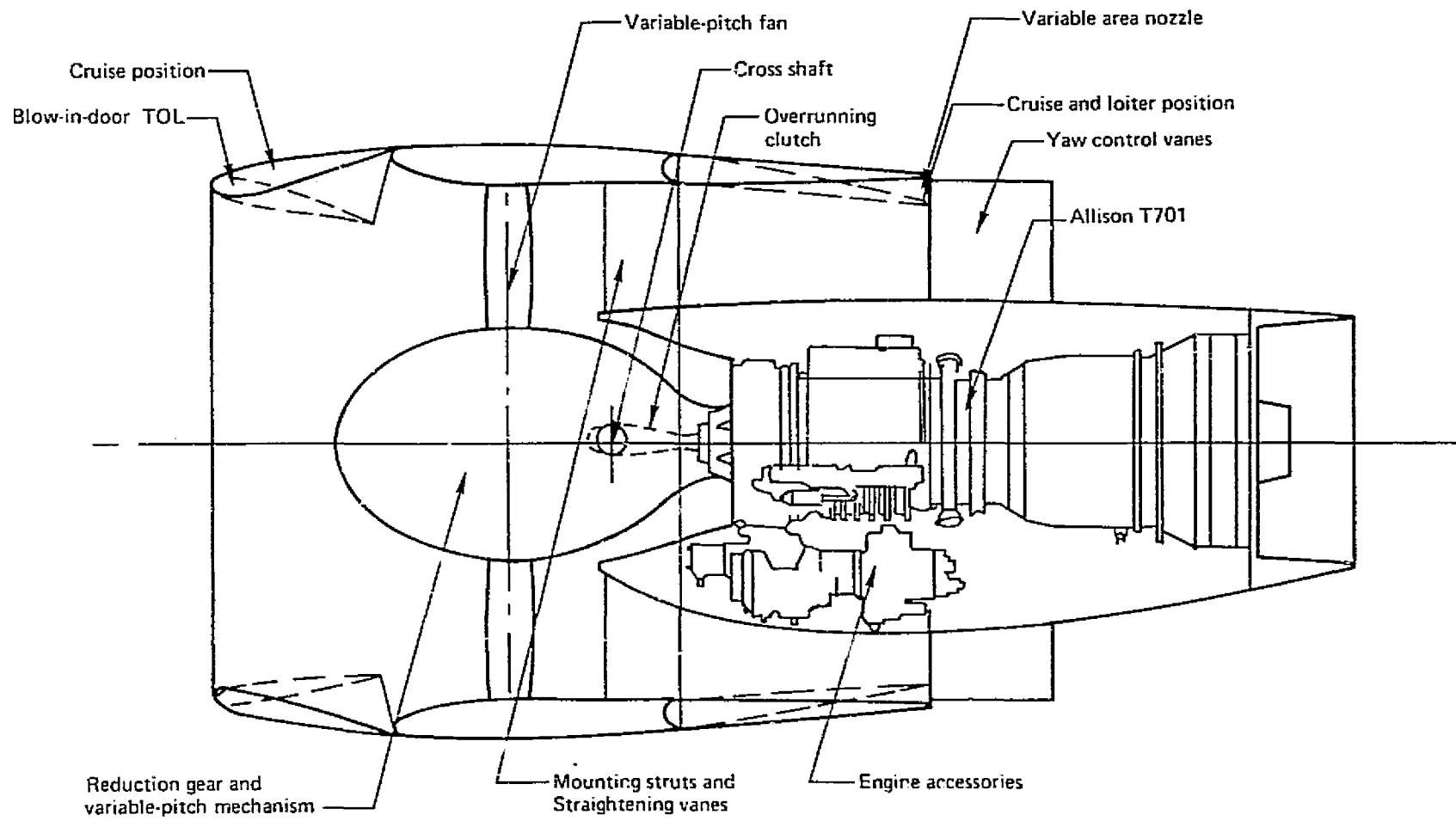

Figure 3.3.6-1.—Cruise/Lift Fan/Engine Propulsion Pod

Any minor thrust trimming required will be accomplished with the variable fan pitch on each fan. Installed engine performance data used for the 1041-133-1 configuration STOL takeoff and landing conditions are listed in Table 3.3.6-1 for sea level 90<sup>0</sup>F day operating conditions.

#### Turbo Shaft Engine and Fan (PD 370-15)

The engine used in the 1985 operational airplane is a growth version of the Allison T701 turboshaft engine. The engine is an outgrowth of Allison's advanced technology program.

The fans are Hamilton-Standard 62 inch diameter variable pitch fans. The technology is to be based on Hamilton Standard's experience with their Q-Fan demonstrator and NASA variable pitch fan wind tunnel models. A comparison of the growth version with the current engine is shown in Table 3.3.6-2.

The fan characteristics include:

Tip diameter	62 inches
Hub to tip ratio	.425
Design tip speed	955 fps
Number of blades	26
Nominal pressure ratio	1.2

The cross section view of the advanced T701 lift/cruise variable pitch turbofan engine is shown on Figure 3.3.6-2.

#### Inlet

A V/STOL airplane with tilting lift-cruise nacelles puts the inlets into very high angle-of-attack conditions during transition, particularly during the landing maneuver. The inlet is required to operate at angles near 90<sup>0</sup> combined with speeds up to 100 knots.

An inlet model with a blow-in door inlet was tested. The model is shown in Figure 3.3.6-3. This inlet was tested at speeds up to 150 knots, crossflow angles of 0, 40<sup>0</sup>, 60<sup>0</sup> and 90<sup>0</sup> and corrected airflows from 34 to 42.5 lb/sec ft<sup>2</sup> at the fan face.

*Table 3.3.6-1.-Installed Static Performance Sea Level 90° F Day*

Condition	FPR	Burner exit temp	Thrust, lb	SFC, lb/lb hr
STOL 2 engines/2 fans	1.28	2490° F	28,000	.309
VTOL 2 engines/3 fans	1.185	2540° F	34,000	.271
Contingency 1 engine/3 fans	1.14	2750° F	25,300	.226

Table 3.3.6-2.—Comparison of Current to Growth T701 Engine

PARAMETER	T-701	PD370-15
POWER ~ HP SEA LEVEL 90°F DAY	7540	11250
* WEIGHT ~ LB.	1070	1219
CORRECTED AIRFLOW ~ LB/SEC	43.6	53.5

\* WITHOUT FORWARD FRAME

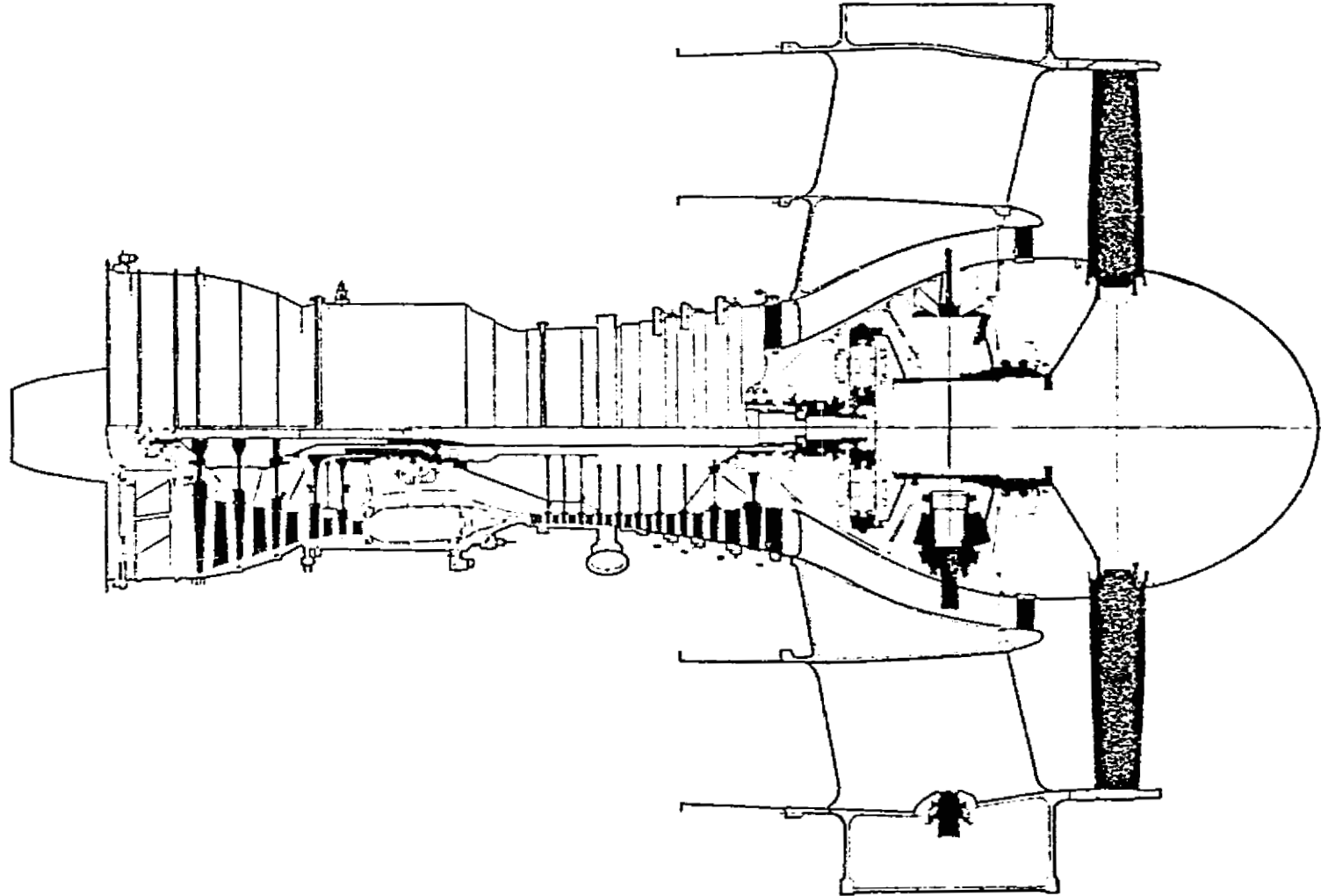
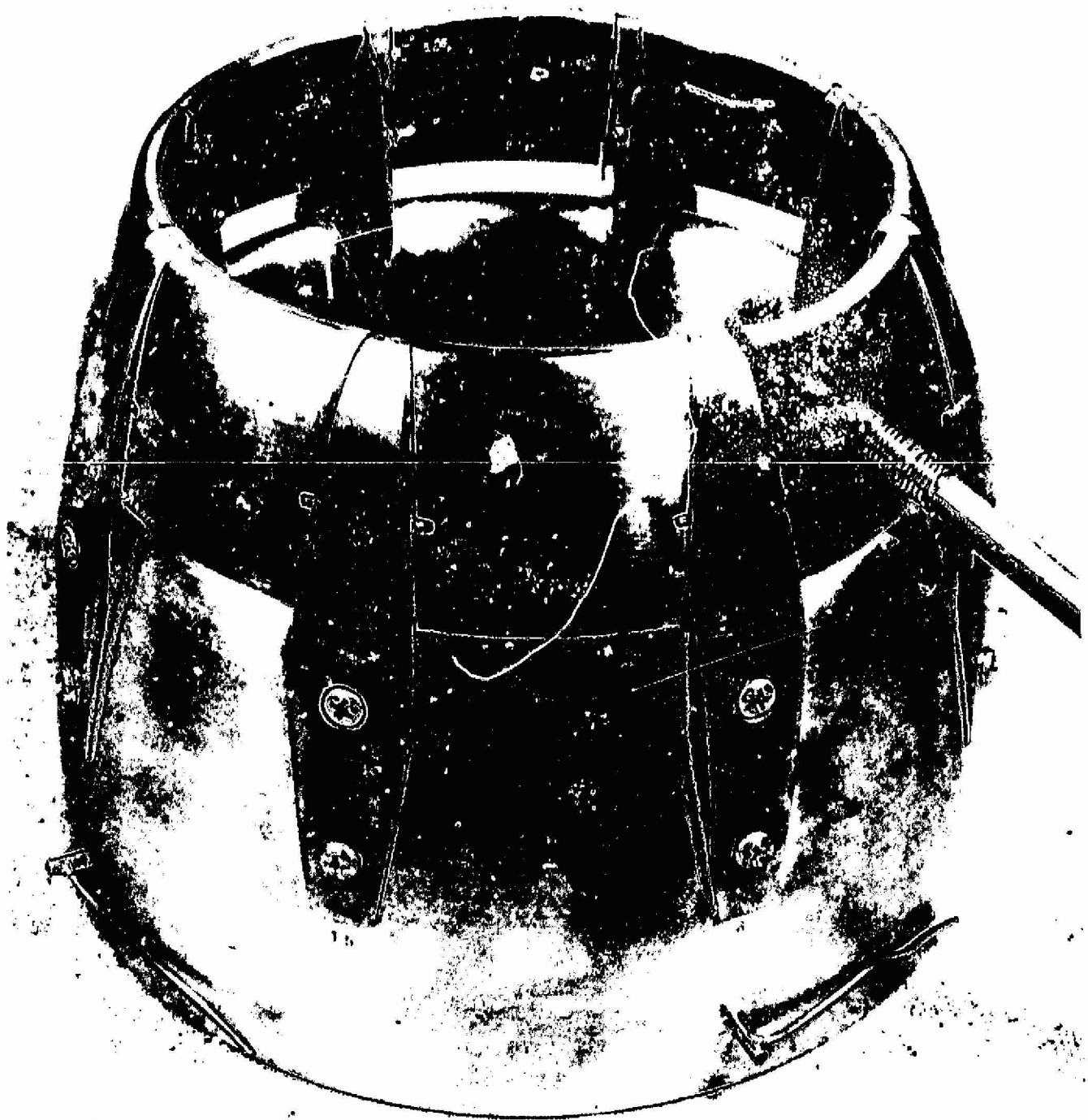

Figure 3.3.6-2.-Advanced T701 Compound Lift Cruise Turbofan Turboshaft Engine



*Figure 3.3.6-3.-Variable Geometry Inlet Model*

The installed propulsion system performance (Appendix B) used in the V/STOL mission studies, reflects this data. Test results are shown in Appendix D.

Fan inlet total pressure distortion was obtained and is within the tolerance of the engine and fan. The engine airflow (7% of total fan airflow) passes through the hub region of the fan and has less distortion than the fan.

### 3.3.7 Drive System

The power train is shown schematically in Figure 3.3.7-1. It consists of the overrunning clutches which allows an inoperative engine to drop off the line, engine star reduction gearing, fan bevel gear sets, cross shafts, lift fan drive shaft, clutch, combining (tee) box and accessory drive takeoff.

An overrunning clutch is installed on each engine power shaft output drive. The technology is similar to that currently used with helicopter drives.

The cross shaft bevel gear set is straddle-mounted between the fan shaft bearings. It provides the gear ratio match required by the cross shaft and the initial power exchange link between the fans.

The forward fan bevel gear drive installation is similar to the cross-shaft bevel set and reduces the rpm at the front fan.

The lateral shaft design between the engine mount and the combiner gearbox is relatively short and well supported. A 1½ inch diameter steel shaft is used to minimize flow interference. The lift fan drive shaft consists of three elements of shafting with four flexible connectors. The shafts are similar to those used on all Boeing helicopters.

ORIGINAL PAGE IS  
OF POOR QUALITY

100

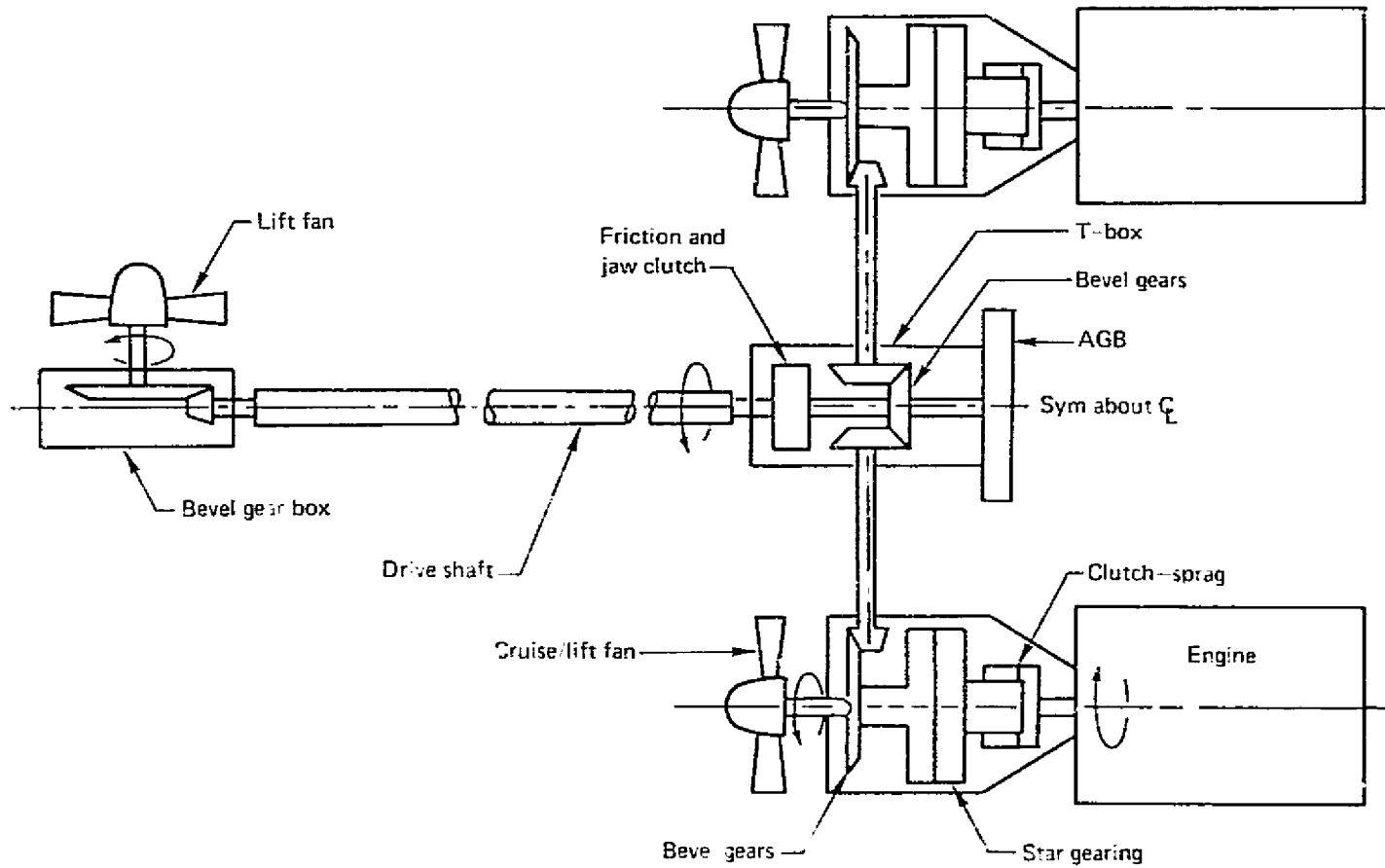

Figure 3.3.7-1.-Power Train Schematic



The tee box provides the element that allows both lift/cruise fan engines to effect a power exchange and to provide power to the forward lift fan.

The clutch is mounted on the front of the tee box. The engaging mechanism consists of friction discs to synchronize speed and a positive engagement jaw clutch. The friction clutch utilizes carbon graphite discs faces developed from the HLI rotor brake technology.

### 3.3.8 Weights and Balance

The weights were determined parametrically in conjunction with the NASA/Navy V/STOL design criteria.

The weight statement and dimension and structural data for the ASW configuration are presented in Table 3.3.8-1 and 3.3.8-2. The individual structural group weights have been determined for a current technology (aluminum) aircraft. A 10% weight improvement has been included to account for advanced technology improvements commensurate with initial operations in 1985.

The operating weight center of gravity and location of ASW expendable load produce the envelope of most forward and aft center of gravity and weight conditions for the Model 1041-133-1 configuration. (Figure 3.3.8-1).

The list of special features which are related to V/STOL capability are listed in Table 3.3.9-3.

The inertias are listed in Table 3.3.8-4.

### 3.3.9 Flight Controls

The Flight Control Systems consists of conventional aerodynamic control and reaction control for V/STOL operation. The reaction control is achieved by modulation and deflection of the thrust vectors. The blending of the two systems is straight forward with the aerodynamic system increasing in authority with increasing flight speed. A fly-by wire system with a digital flight control computer is used.

Table 3.3.8-1.-Multimission Airplane, Model 1041-133-1

	ASW MISSION WT. LBS	HORIZ. CG STA INCHES	
WING	2010	397	
HORIZONTAL TAIL	270	632	
VERTICAL TAIL	140	600	
BODY & STRAKE	3740	375	
MAIN GEAR	1100	417	
NOSE GEAR	190	265	
NACELLE OR ENG SECTION	2320	440	
AIR INDUCTION	-	-	
10% WT. REDUCTION	-800	408	
STRUCTURE	(7920)	(408.1)	
FANS	1320	374	
ENGINE	2000	507	
ENGINE ACCESSORIES	100	265	
FUEL SYSTEM	350	390	
ENGINE CONTROLS	80	370	
STARTING SYSTEM	80	490	
DRIVE SYSTEM	2650	405	
PROPULSION	(7480)	(437.5)	
AUXILIARY POWER UNIT	-	-	
INSTRUMENTS & NAV EQUIP	250	320	
FLIGHT CONTROLS	750	420	
HYDRAULIC/PNEUMATIC	230	370	
ELECTRICAL	650	320	
AVIONICS	2700	272	
ARMAMENT	310	391	
FURNISHINGS & EQUIP	270	315	
AIR COND & ANTI-ICING	650	334	
AUXILIARY GEAR	-	-	
RADAR REFLECTIVITY RED.	-	-	
LOAD & HANDLING	20	390	
FIXED EQUIPMENT	(6500)	(318.2)	
WEIGHT EMPTY	21900	391.5	30.3%
CREW	720	315	
CREW PROVISIONS	180	315	
OIL & TRAPPED OIL	90	430	
UNAVAILABLE FUEL	110	387	
PAYLOAD PROVISIONS	500	412	
WEAPON BAY FUEL PROV	-	-	
NON-EXP USEFUL LOAD	(1600)	(356.7)	
OPERATING WEIGHT	23500	383.1	27.0%
(2) TORECOES	1060	330	
(5) SONOBUOYS	1760	430	
PAYLOAD (INCL EXP PEN AIDS)	-	-	
FUEL-WING	12076	357	
FUEL-BODY			
STD GROSS WEIGHT	38390	388.7	27.3%

LEMAC 0 BSTA 363

MAC LENGTH = 94 in.

ORIGINAL PAGE IS  
OF POOR QUALITY

Table 3.3.8-2.-Group Weight Statement Dimensional and Structural Data

A: 9103-11  
 NAME WLM GROUP WEIGHT STATEMENT PAGE  
 DATE 3/75 DIMENSIONAL & STRUCTURAL DATA MODEL LCFA-33-1  
 REPORT

1	LENGTH - OVERALL (FT.)	46.5				HEIGHT - OVERALL - STATIC (FT.)			16.9
	LENGTH - MAX. (FT.)	Main Floats	Aux. Floats	Beams	Fuse or Hull	Inboard	Outboard	Y. Tail	
4	DEPTH - MAX. (FT.)				43.7	11.7			
5	WIDTH - MAX. (FT.)				6.6	6.0			
6	WETTED AREA (SQ. FT.)				6.6	6.0			
7	FLOAT OR HULL DISPL. - MAX. (LBS.)				773.0	111.0			
8	FUSELAGE VOLUME (CU. FT.)	PRESSURIZED				TOTAL			
9						Wing	H. Tail	Y. Tail	
10	GROSS AREA (SQ. FT.)					310.0	64.0	37.5	
11	WEIGHT/GROSS AREA (LBS./SQ. FT.) (CONVENTIONAL ALONE, WT.)					6.5	4.2	3.7	
12	SPAN (FT.)					41.3	18.0	6.2	
13	FOLDED SPAN (FT.)					20.0			
14									
15	SWEEPBACK - AT 25% CHORD LINE (DEGREES)					4.0	11.3	30.0	
16	- AT % CHORD LINE (DEGREES)					17.0	15.0	35.0	
**17	THEORETICAL ROOT CHORD - LENGTH (INCHES)					120.1	57.5	32.0	
18	- MAX. THICKNESS (INCHES)					18.0	8.6	13.8	
**19	CHORD AT PLANFORM BREAK - LENGTH (INCHES)								
20	- MAX. THICKNESS (INCHES)								
**21	THEORETICAL TIP CHORD - LENGTH (INCHES)					60.0	28.8	54.0	
22	- MAX. THICKNESS (INCHES)					6.0	2.9	5.4	
23	DORSAL AREA, INCLUDED IN (Y TAIL) AREA (SQ. FT.)							1.2	
24	TAIL LENGTH - 25% MAC WING TO 25% MAC H. TAIL (FT.)							20.5	
25	AREAS (SQ. FT.)	Flaps	L. E.	T. E.	31.3				
26		Lateral Controls	Slats	Spillars			Ailerons	34.2	
27		Speed Brakes	Wing	Fuse. or Hull					
28									
29									
30	ALIGHTING GEAR (LOCATION)				MAIN		HOSE		
31	LENGTH - OLEO EXTENDED - $\phi$ AXLE TO $\phi$ TRUNNION (INCHES)				63.0		50.0		
32	OLEO TRAVEL - FULL EXTENDED TO FULL COLLAPSED (INCHES)				15.0		13.0		
33	FLOAT OR SKI STRUT LENGTH (INCHES)								
34	ARRESTING HOOK LENGTH - $\phi$ HOOK TRUNNION TO $\phi$ HOOK POINT (INCHES)								
35	HYDRAULIC SYSTEM CAPACITY (GALS.)								
36	FUEL & LUBE SYSTEMS	Location	No. Tanks	****Gals. Protected	No. Tanks	****Gals. Unprotected			
37	Fuel - Internal	Wing				1681			
38		Fuse. or Hull							
39	- External								
40	- Bomb Bay								
41									
42	Oil								
43									
44									
45	STRUCTURAL DATA - CONDITION				Fuel In Wings (Lbs.)	Max. Gross Weight	Ult. L.F.		
46	FLIGHT					33180	4.5		
47	LANDING					32700			
48									
49	MAX. GROSS WEIGHT WITH ZERO WING FUEL								
50	CATAPULTING								
51	MIN. FLYING WEIGHT								
52	LIMIT AIRPLANE LANDING SINKING SPEED (FT./SEC.)						15.0		
	WING LIFT ASSUMED FOR LANDING DESIGN CONDITION (%W)								
	STALL SPEED - LANDING CONFIGURATION - POWER OFF (KNOTS)								
55	PRESSURIZED CABIN - ULT. DESIGN PRESSURE DIFFERENTIAL - FLIGHT (P.S.I.)						8.6		
56									
57	AIRFRAME WEIGHT (AS DEFINED IN AH-W-11) (LBS.)								

\*Lbs. of sea water @ 64 lbs./cu. ft.  
 \*\*Parallel to  $\phi$  at  $\phi$  airplane.  
 > MEASURED FROM TOP OF BODY

\*\*\*Parallel to  $\phi$  airplane.  
 \*\*\*\*Total usable capacity.

ORIGINAL PAGE IS  
 OF POOR QUALITY

T01

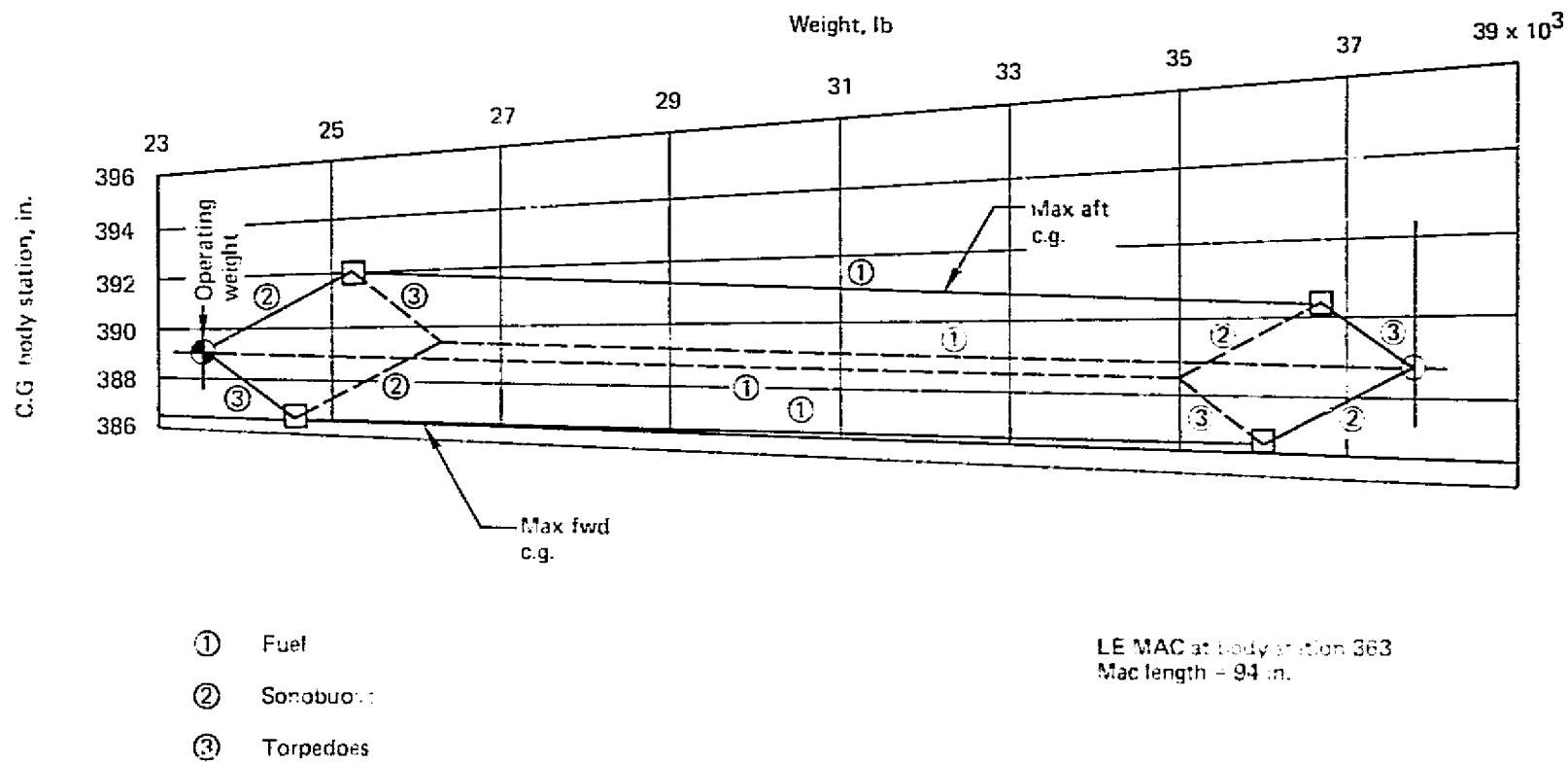

Figure 3.3.8-1.—Center-of-Gravity Loading Diagram Model LCFA-133-1 (ASW)

*Table 3.3.8-3.-Weight Increments for Special Features*

Item	Weight, lb/ac plane
Lift/cruise engine pod rotation	+450
T tail	+30
Transmission system	+650
Forward lift fan installation	+350

**ORIGINAL PAGE IS  
OF POOR QUALITY**

Table 3.3.8-4.—ASW Inertia

	WEIGHT LB.	$I_x$	$I_y$ SLUG-FT <sup>2</sup>	$I_z$	$I_{xz}$
VERTICAL LANDING WEIGHT	32800	22300	56200	70700	7400
STO GROSS WEIGHT	37750	22500	56700	71300	7400

The V/STOL flight control system is based on the use of shaft driven interconnected variable pitch fans. The fans operate at constant rotational speed. Variations in the fan blade angle (pitch) controls the thrust and the demand for engine power by each fan. These thrust variations are used for trim and control. Control capability for normal and emergency operation meets or exceeds the design guidelines. Since a single engine can drive all three fans through the transmission system, the airplane will tolerate an engine failure without a decay in attitude control power. Engine out emergency conditions result in a negligible trim change. Control system mechanization is fly-by-wire with control augmentation capability. A digital computer will manage the various elements of the flight control system. Computation signal transmission, actuation, hydraulic power and electrical power will have fail-operational capability through monitored redundancy.

#### 3.3.9.1 Control System Description

Aerodynamic control and trim is accomplished by conventional aileron, rudder and horizontal stabilizer surfaces. Stabilizer trim setting during transition will be scheduled as a function of flight condition and airplane configuration to minimize pitching moment variation. The aerodynamic control surfaces will operate throughout the hover and transition flight mode.

Hover and low speed control is accomplished by modulation and deflection of the thrust. Pitch and roll control result from differential thrust. Thrust modulation is achieved by varying fan blade pitch angle which gives excellent dynamic response. Yaw control is by thrust deflection and differential fan blade pitch commands will be scheduled as a function of nacelle incidence to decouple roll and yaw control inputs for nacelle incidences between zero and  $90^{\circ}$  (Figure 3.3.9-1).

A triplex digital primary system is used on the airplane; it is considered representative of the technology that will be available and would be required for the complex operational tasks of a 1985 operational airplane. It offers the possibility for the most complete integration of the guidance and navigation functions with the primary flight control system.

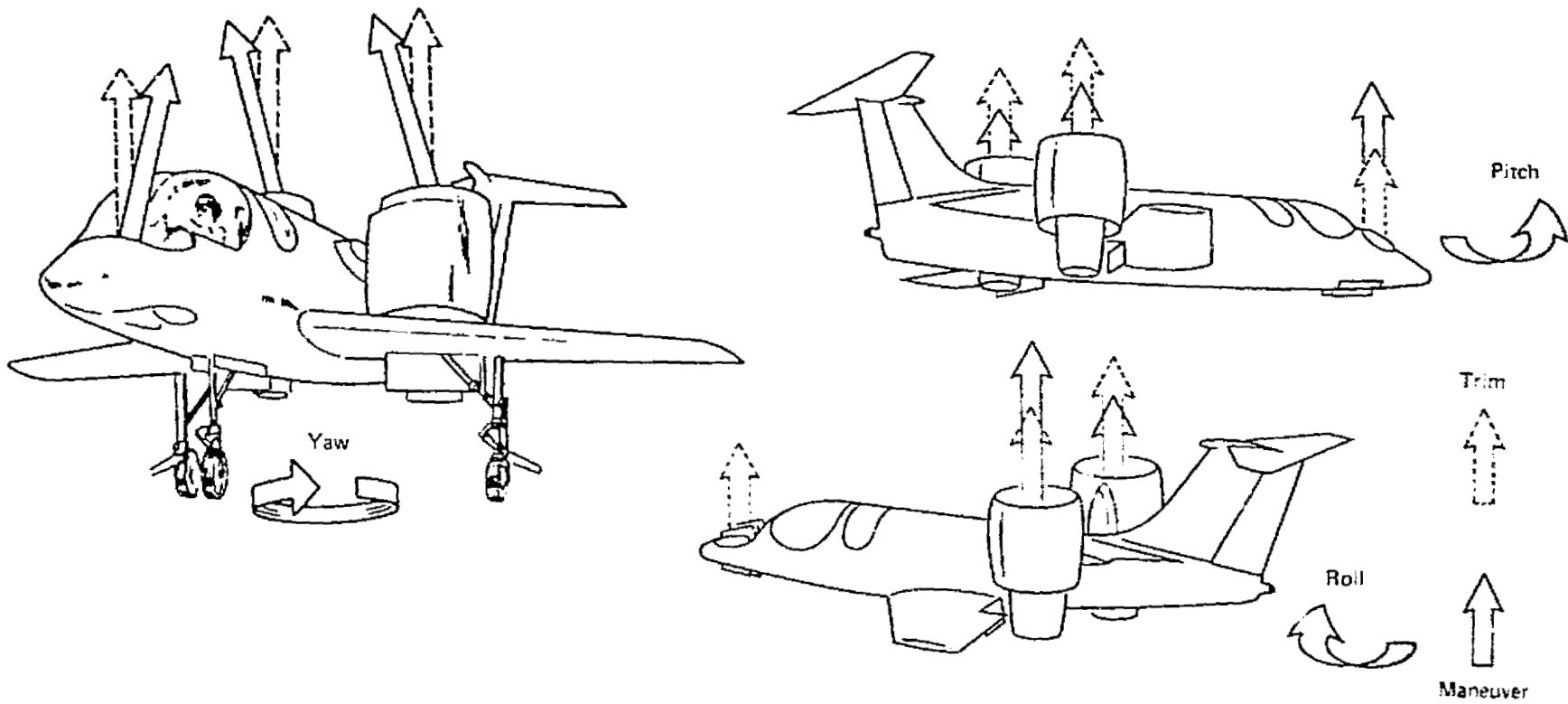

Figure 3.3.9-1.-Pitch/Roll/Yaw Control



The control system functions are based on piloted simulation results. The mechanization of these functions is based on YC-14 and HLH development.

The interaction between the Flight Control system and the propulsion system is apparent in the block diagram, Figure 3.3.9.2. The blending of aerodynamic and reaction controls is also indicated.

The flight control system is shown schematically on Figure 3.3.9.4. The flight control computer generates command signals for the actuation systems resulting from pilot input and airplane motion sensed from inertial and air data sensors. All interconnections are electrical. Control stick feel is provided artificially and is scheduled by the flight control computer. It also regulates nacelle incidence, fan blade pitch, aerodynamic control surfaces and the fan deflection louvers. The relationship of the actuation systems to the primary controls is shown in more detail on Figure 3.3.9-3. The complexity of the signal mixing within the flight control computer is readily apparent. For instance, the fan blade pitch mechanism on the lift/cruise fans is effected by pitch and roll attitude control, as well as horizontal and vertical velocity commands.

The pilots' primary controls consist of a conventional stick and rudder pedals, a power control lever and a nacelle tilt switch. Figure 3.3.9-4 summarizes the outer loop of the flight control system in which each of the cockpit controls interact. Three speed ranges are considered. "Hover and low speed" blends into "higher transition speeds" in the region of 35 to 40 knots. The phasing from transition to cruise speed occurs about 160 to 200 knots.

At hover and low speed a displacement of the stick commands a pitch attitude and drift velocity. The pitch axis controller is diagrammed on Figure 3.3.9-5. At higher speeds a displacement of the stick commands a proportional pitch rate. When the stick is returned to the neutral position, the airplane is stabilized to the attitude then existing. Manual pitch trim is combined with trim changes as a function of flight condition.

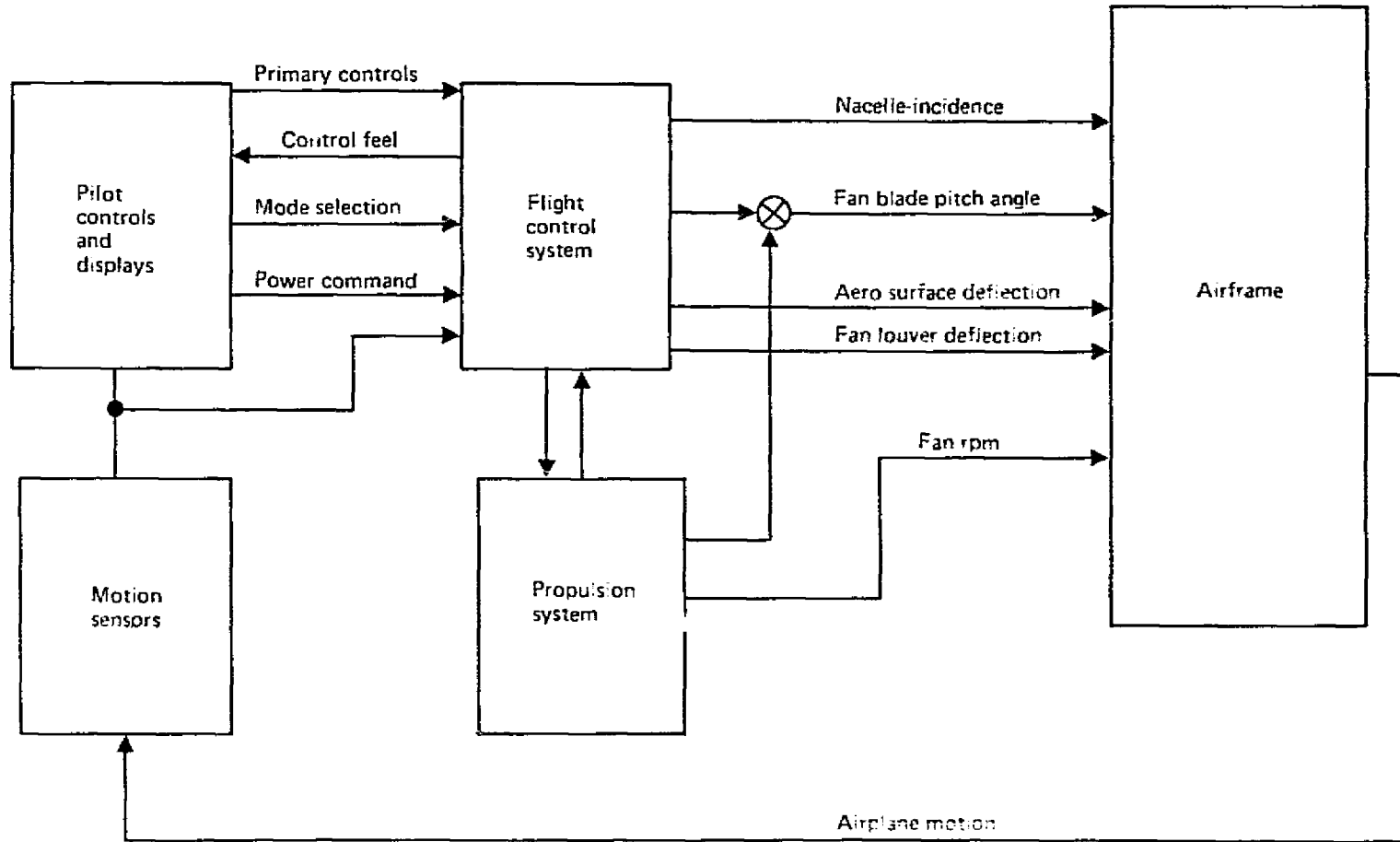

Figure 3.3.9-2.-Flight Control Schematic

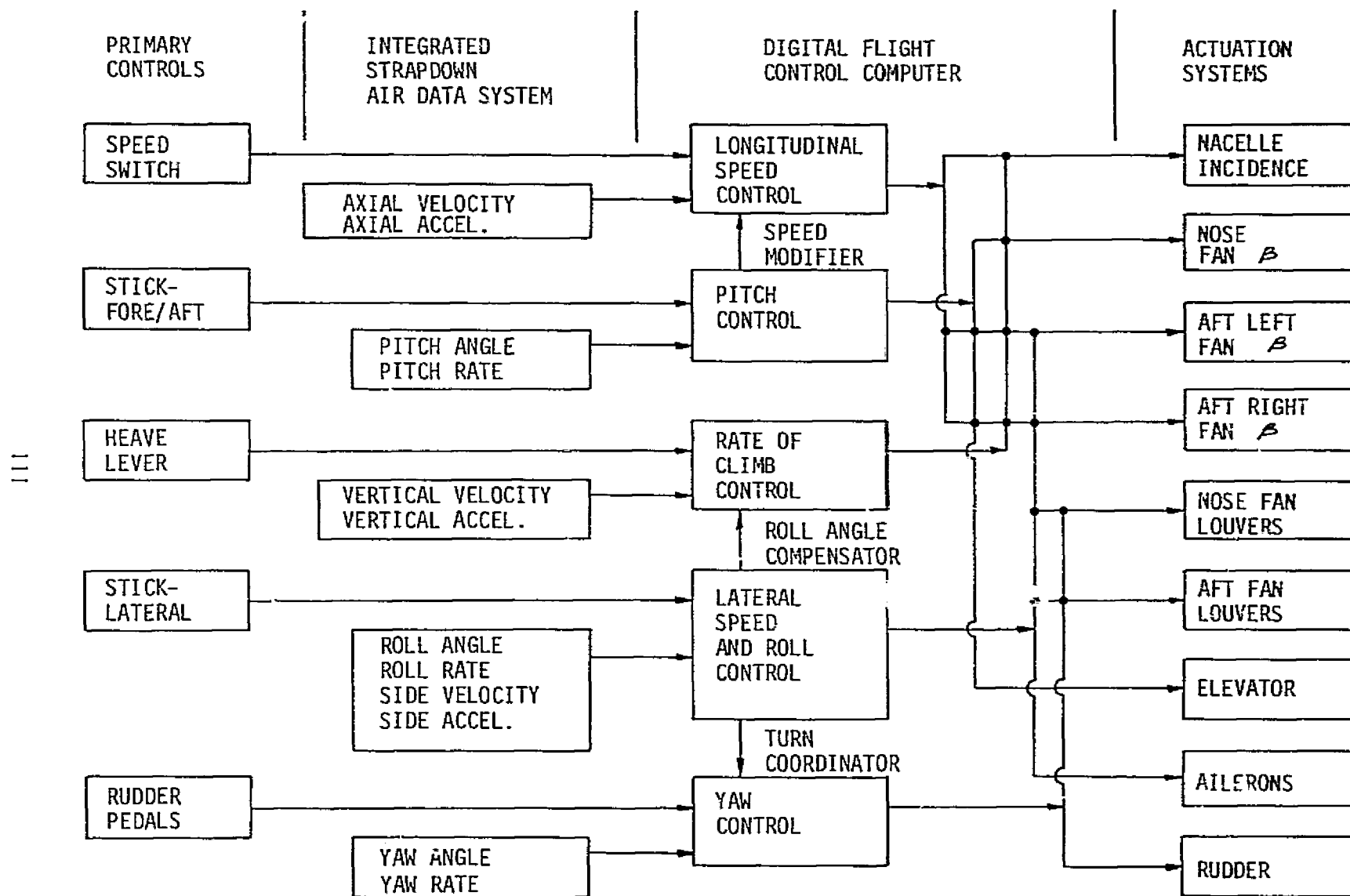

Figure 3.3.9-3.-Flight Control System, Relationship of Primary Controls to Actuation Systems

PRIMARY PILOT CONTROL	SPEED RANGE		
	HOVER AND LOW SPEED	HIGHER TRANSITION SPEEDS	CRUISE
STICK (FORE/AFT)	PITCH ATTITUDE WITH DRIFT VELOCITY	PITCH RATE WITH ATTITUDE HOLD	PITCH RATE WITH ATTITUDE HOLD
STICK (LATERAL)	SIDE VELOCITY	$\emptyset < 4^\circ$ BANK ANGLE $\emptyset > 4^\circ$ ROLL RATE WITH BANK ANGLE HOLD	$\emptyset < 4^\circ$ BANK ANGLE $\emptyset > 4^\circ$ ROLL RATE WITH BANK ANGLE HOLD
RUDDER PEDALS	YAW RATE WITH HEADING HOLD	YAW RATE WITH TURN COORDINATION	YAW RATE WITH TURN COORDINATION
HEAVE LEVER, THROTTLE	RATE OF CLIMB WITH ALTITUDE HOLD	RATE OF CLIMB	FAN THRUST (PILOT OPTION)
VELOCITY SWITCH	GROUND SPEED	GROUND SPEED	GROUND SPEED (PILOT OPTION)

Figure 3.3.9-4.—Flight Control Modes

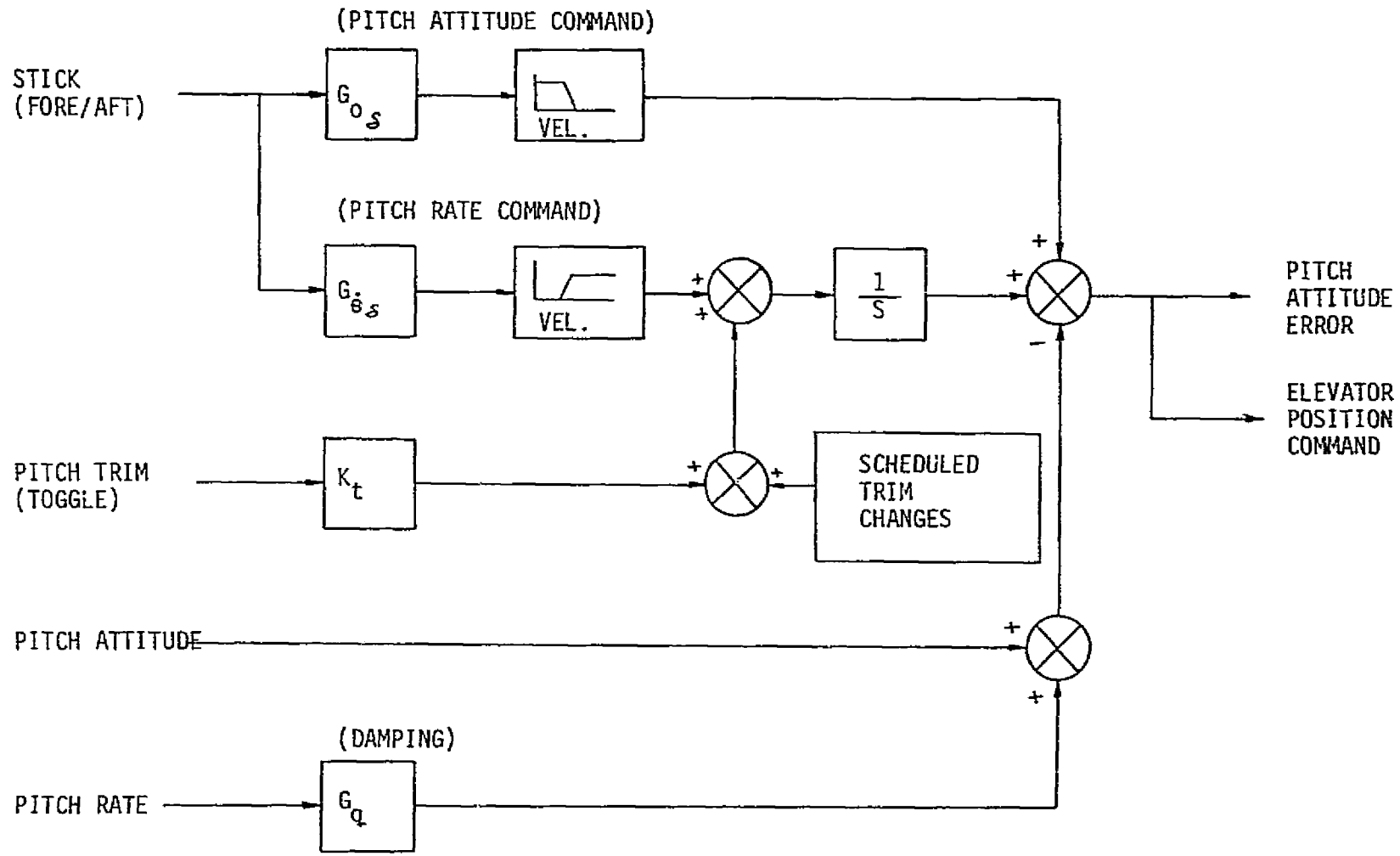

Figure 3.3.9-5.-Pitch Attitude Controller

The speed switch, mounted on the power lever, drives the commanded forward velocity. The velocity command is displayed on the instrument panel. Figure 3.3.9-6 schematically shows the horizontal speed controller. The pitch attitude input provides an incremental velocity command at low speed. During cruise, at the pilot's option, the speed control can be turned off.

Lateral stick position commands a side velocity at hover and low speed. At higher speed a small displacement of the stick commands a proportional roll angle up to  $4^{\circ}$  and returning the stick to neutral commands a wings level attitude. Larger lateral stick displacement commands a proportional roll rate and returning the stick to neutral holds the existing bank angle, or returns the airplane to a level attitude if the bank angle was less than  $4^{\circ}$ . A block diagram of the roll angle and side velocity controller is shown on Figure 3.3.9-7.

The yaw axis controller shown on Figure 3.3.9-8. At hover and low speed a heading hold mode is engaged when the rudder pedals are neutral to prevent side velocity or roll angle from coupling into yaw motion. At higher speeds, roll attitude and rate are used in the yaw channel to enhance turn coordination. Also included is a yaw damper to provide additional yaw axis stability.

The rate of climb control loop logic is shown on Figure 3.3.3-9. At hover and low speed an altitude hold mode is engaged.

#### 3.3.9.2 Control System Performance

Maneuver control was evaluated for both normal and engine out operation. Two constraints define the control capability of the system. One is the maximum single fan thrust, a structural and aerodynamic limit, and the other is the maximum power that the engines can deliver. The fan thrust limit is well outside of the normal demands for VTOL control, but can be reached on the Lift/Cruise fan by a simultaneous maximum roll and pitch command. Maximum engine power is a limit that can be encountered under normal operational circumstances. For example, the engine power will increase to

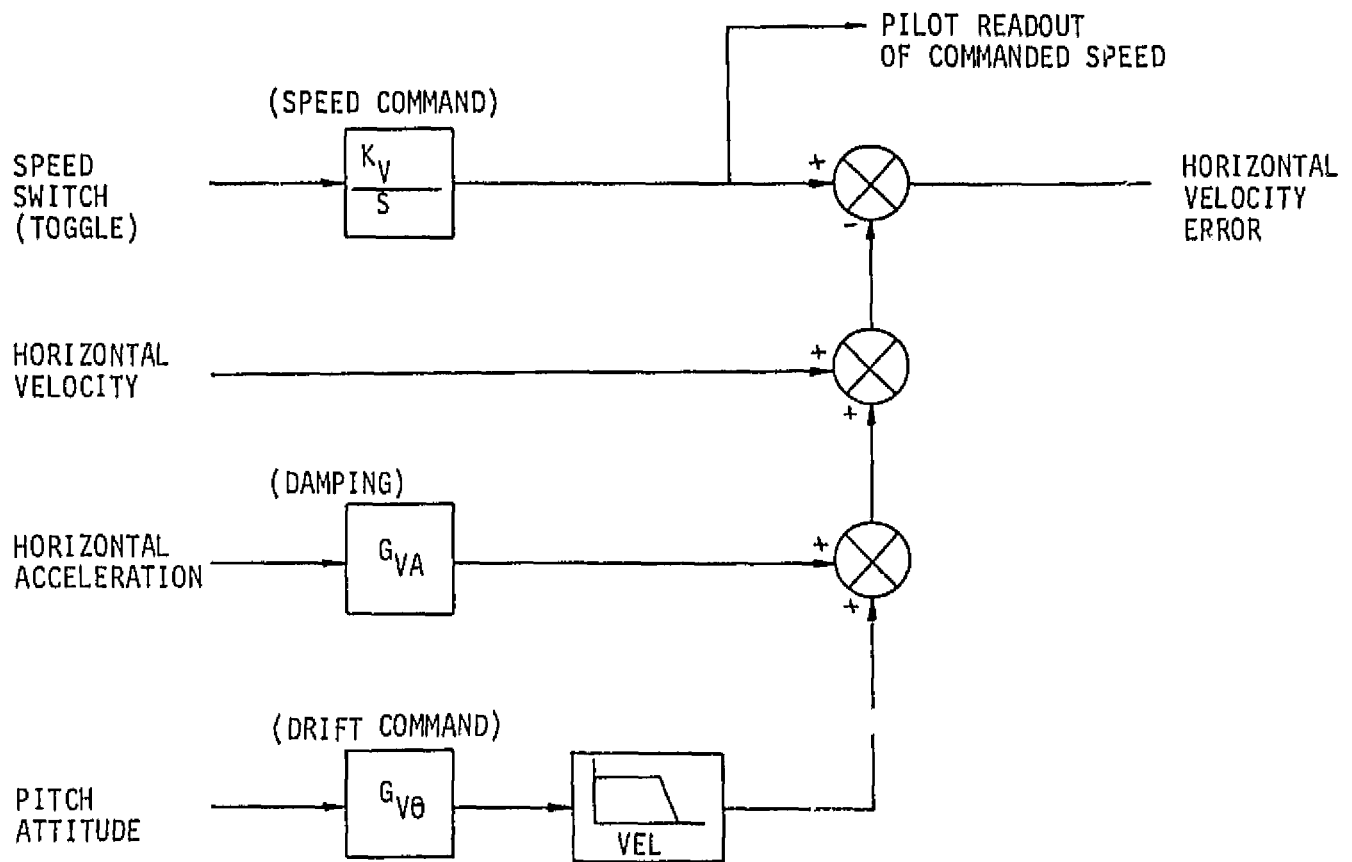

Figure 3.3.9-6.-Horizontal Speed Controller

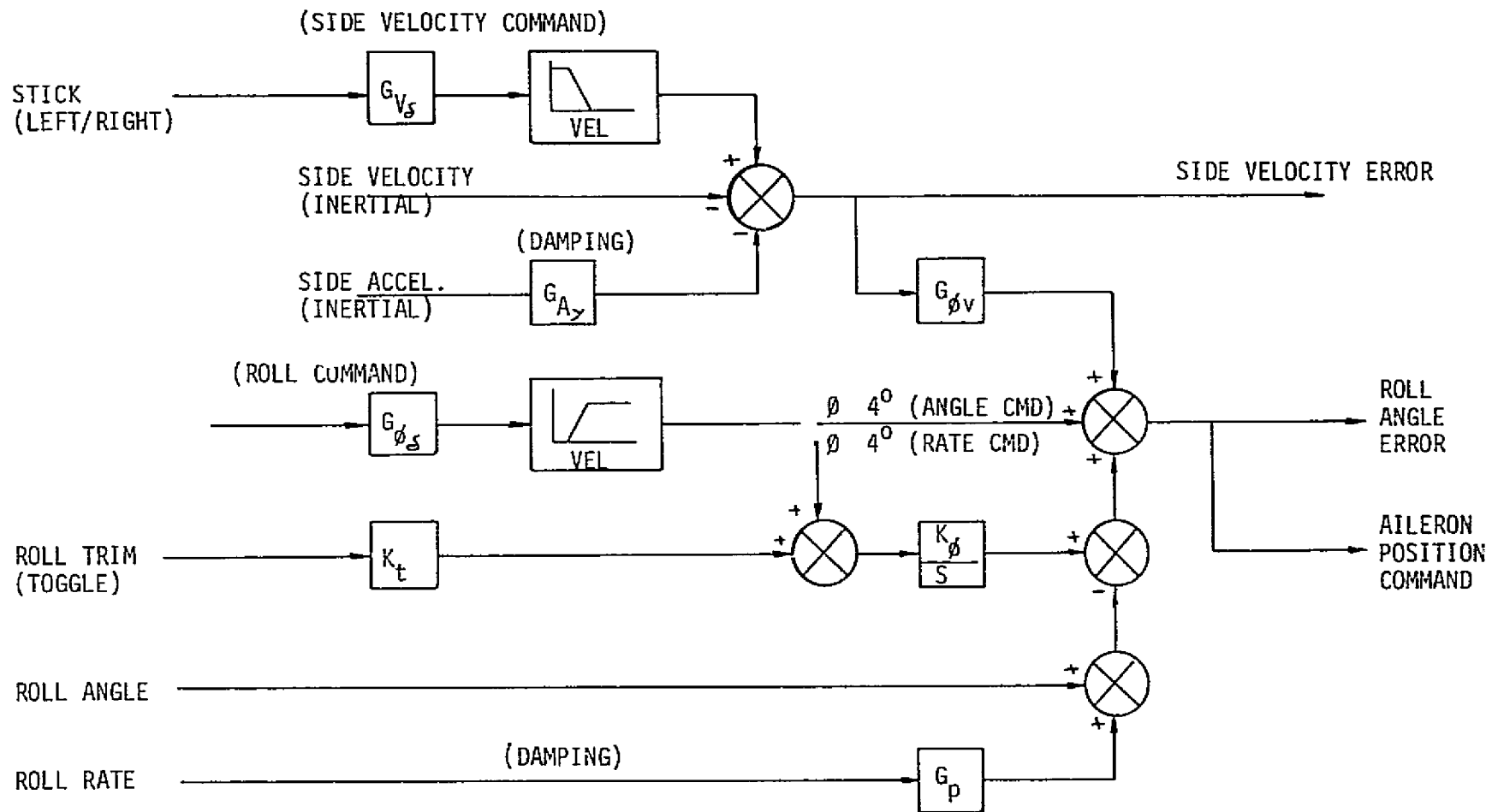

Figure 3.3.9-7.—Roll Angle and Side Velocity Controller



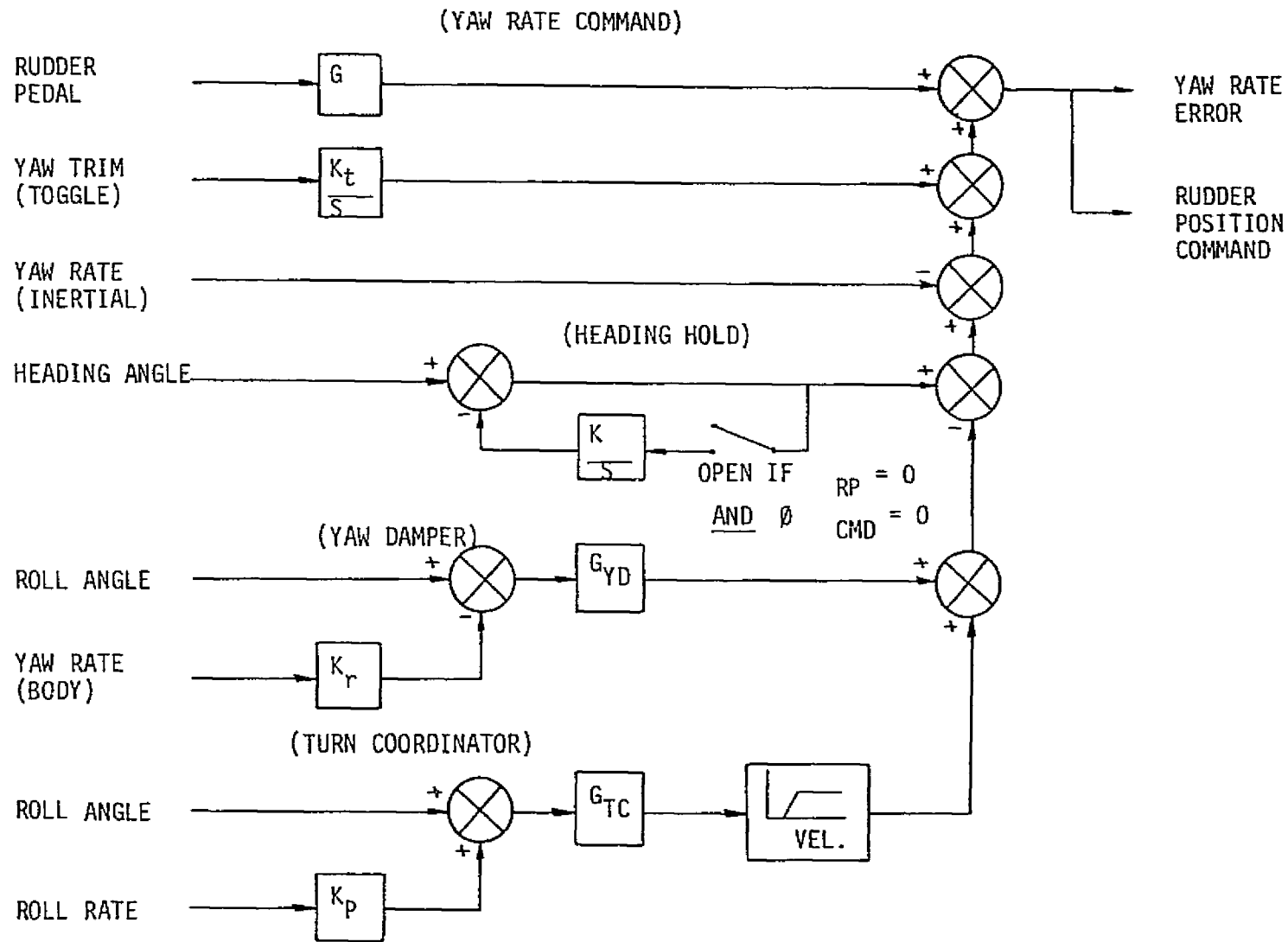

Figure 3.3.9-8.-Yaw Rate Controller

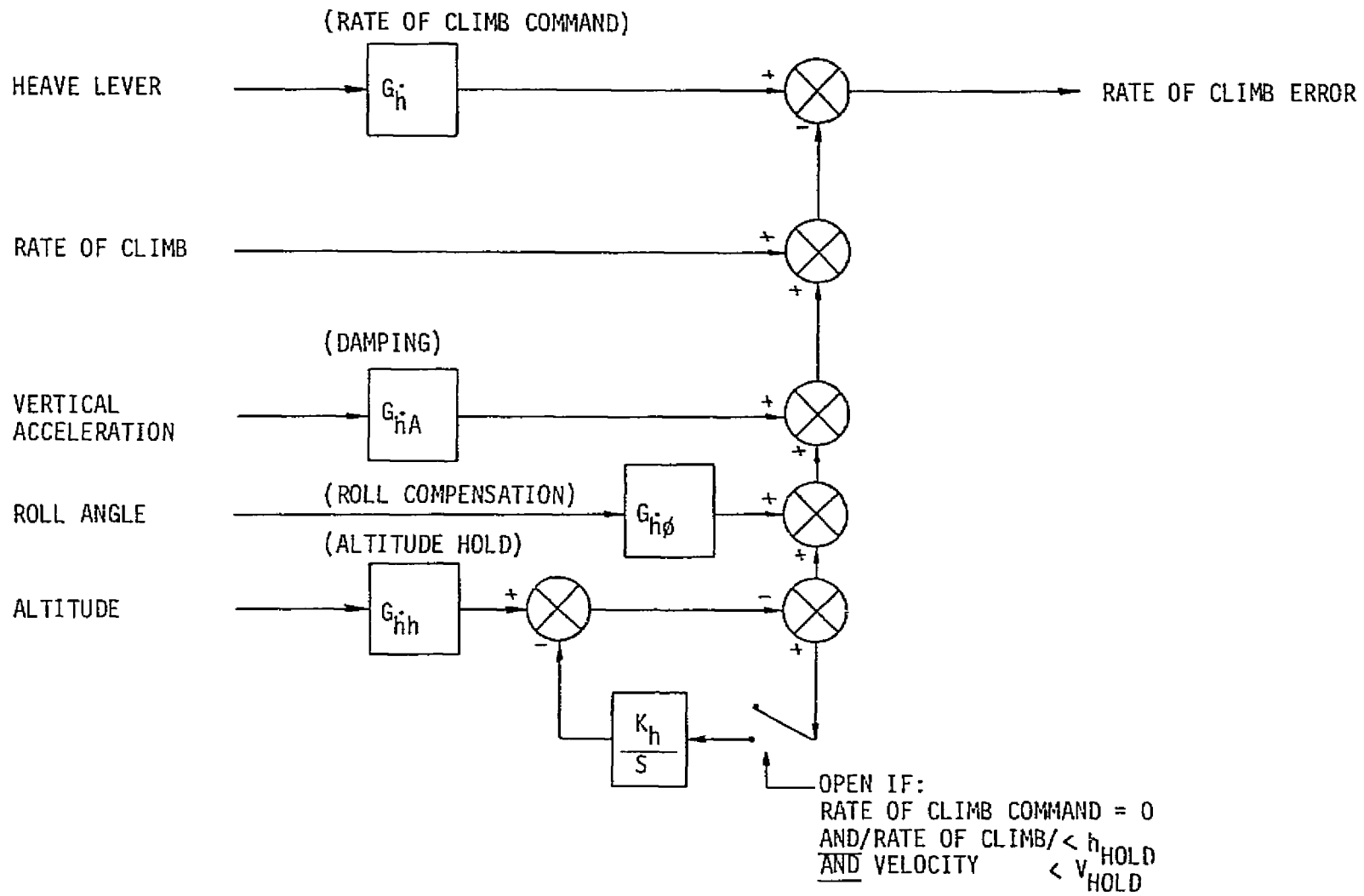

Figure 3.3.9-9.-Rate of Climb Controller

satisfy the constant speed feature of the system. If the power required by the thrust distribution exceeds power available, the fan speed will bleed off until the torque required and the engine power reach a balance. The speed of all operating fans is the same; consequently, the fan speed bleed down will affect all three fans simultaneously. Control system logic will provide a signal when engine power limits are encountered to wash out the blade angle of all three fans until a torque balance at essentially constant speed is achieved. This design feature allocates priority to attitude command.

Figure 3.3.9-10 shows the system capability in terms of lift combined with roll. A command of 100% of design roll has a 2% effect on lift. The figure also illustrates engine out control capability. Engine out control is well above design guideline levels. There is some affect on lift if control commands are sustained for periods that are longer than normally required for maneuvering.

The time response of the control system is excellent and exceeds the design guidelines.

The responses to attitude and flightpath commands are shown in Figure 3.3.9-11. A rolling moment based on a thrust change of  $\pm 30\%$  has a time constant of 0.1 sec. This is near maximum control. For smaller moments the time constant is as low as 0.05 sec. Flightpath control is exemplified by a fly-down command. The thrust is reduced 5% with a time constant of 0.15 sec. This includes the response of the engine to the required change in power level.

Gyroscopic coupling in the hover mode occurs whenever the nacelle incidence is varied or when the airplane pitch or roll attitude is varied.

Figure 3.3.9-12 shows an evaluation of the gyroscopic rolling moments produced by pitching of the engines and fans. When the entire airplane pitches all three fans contribute to the gyroscopic effect.

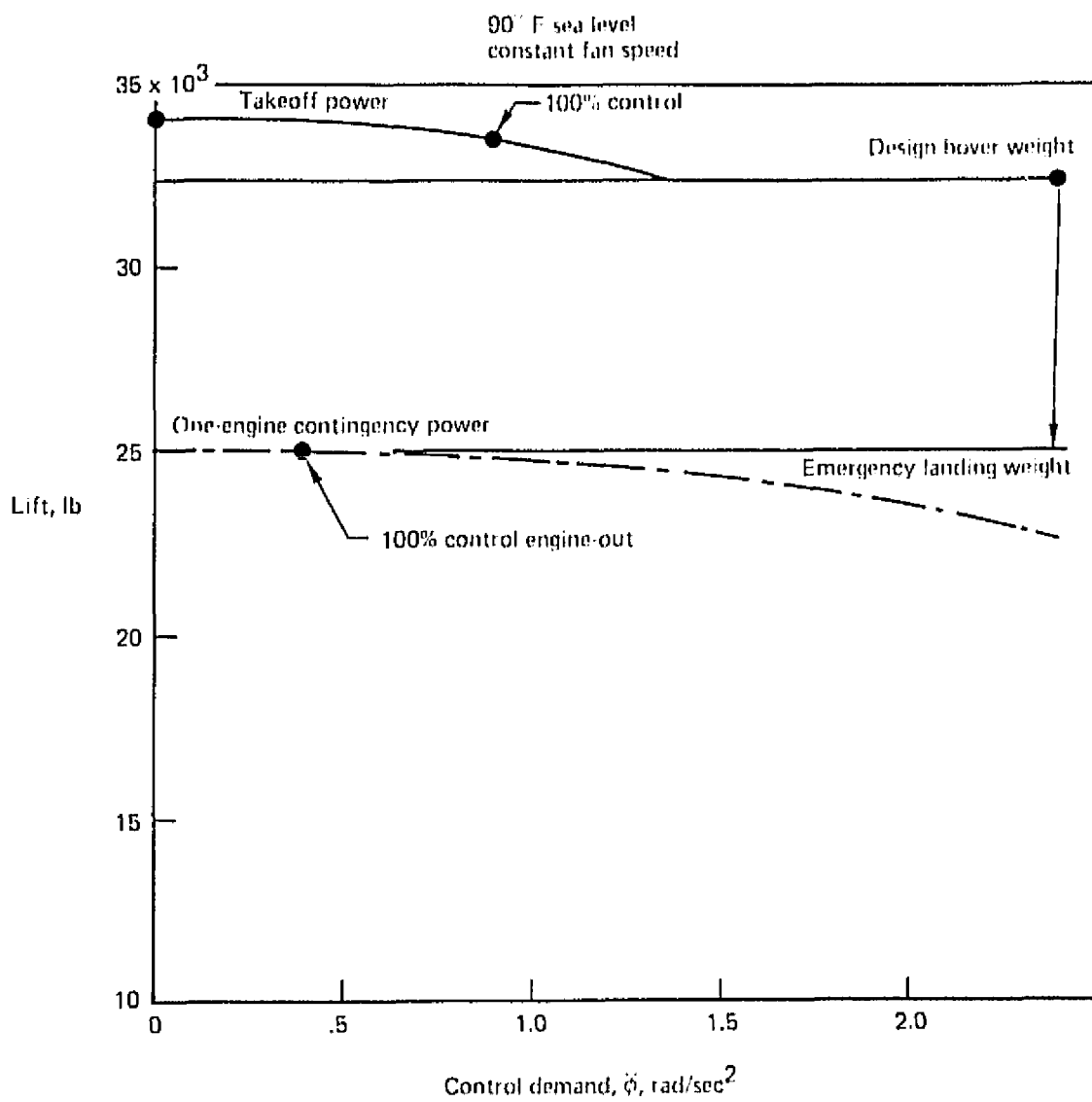

Figure 3.3.9-10.—Roll Control Power Capability, Model 1041-133

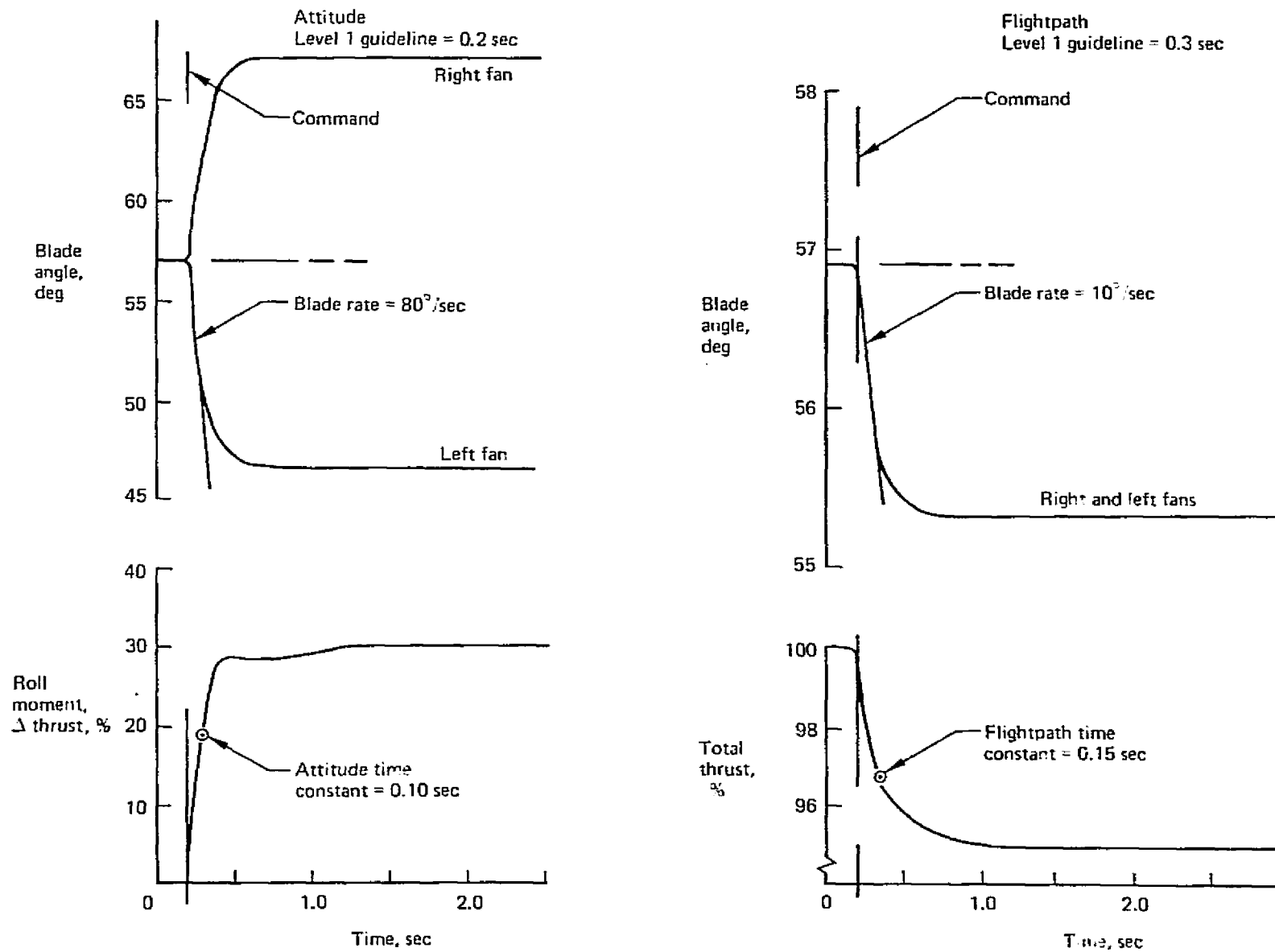

Figure 3.3.9-11.-VISTOL Control System Response

If the lift cruise nacelles are rotated, as for transition, only two fans are involved. The fans and engines rotate in opposite directions which reduces the total angular momentum.

A gyroscopic moment less than 10% of the available control is considered acceptable. From the figure, it is apparent that the airplane can be operated with a nacelle incidence rate of about 22 degrees/second or an attitude rate of 11 degrees/second and require only 10% of the roll to

compensate for the induced roll moment. The evaluation was made for a nominal hovering condition with the fans and engines at maximum angular momentum. The fan and engine polar moments of inertia are based on Hamilton-Standard estimates for a 62 inch fan with Borsic aluminum blades. The rpm, the polar moments of inertia and the angular moments are:

<u>Component</u>	rpm	Polar Mom. of Inertia Slug-ft <sup>2</sup>	<u>Angular Momentum*</u> Slug-ft <sup>2</sup> x rad/sec
Engine Compressor	+15,000	1.1 <sup>a</sup>	+1870
Engine Power Turbine	+11,800	0.81	+1000
Fan**	- 3,500	14.3	-5390
Airplane Pitch Attitude Rate			-10,430
Nacelle Tilt Rate			-5038

\* Positive angular momentum is clockwise when reviewed from rear.

\*\* Includes gear transmission and interconnect shafts.

The fan angular momentum dominates.

The capability to hover in a crosswind is shown on Figure 3.3.9-13. The guideline for a hover in a 25 knot wind is matched by banking the airplane about 5 degrees.

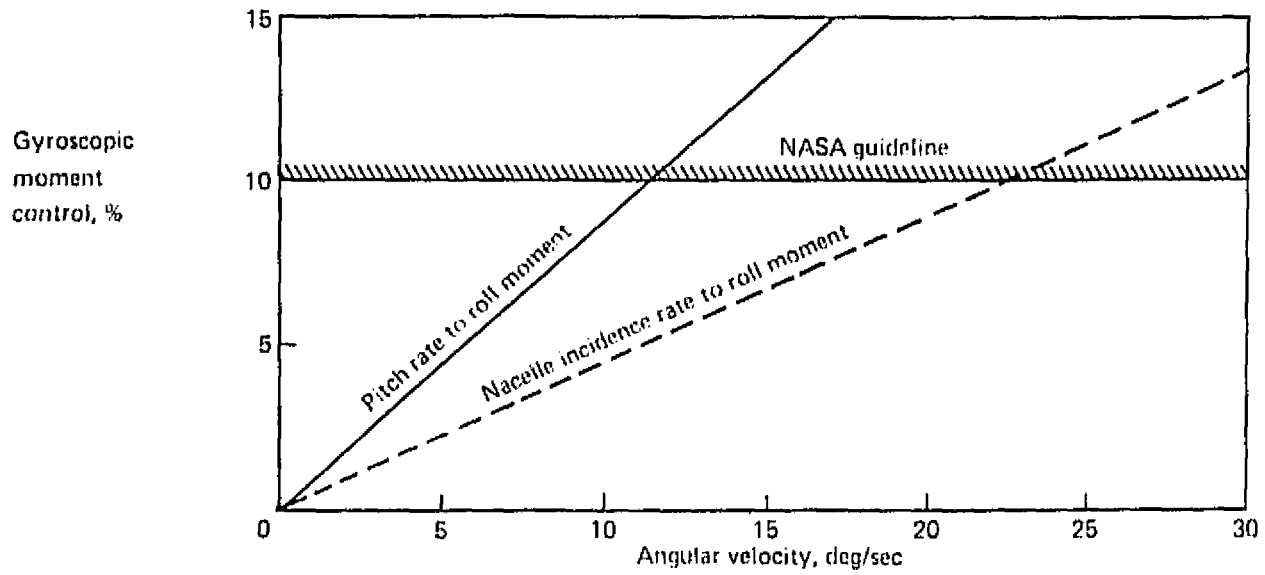

Figure 3.3.9-12.—Hover Gyroscopic Moments, Model 1041-133

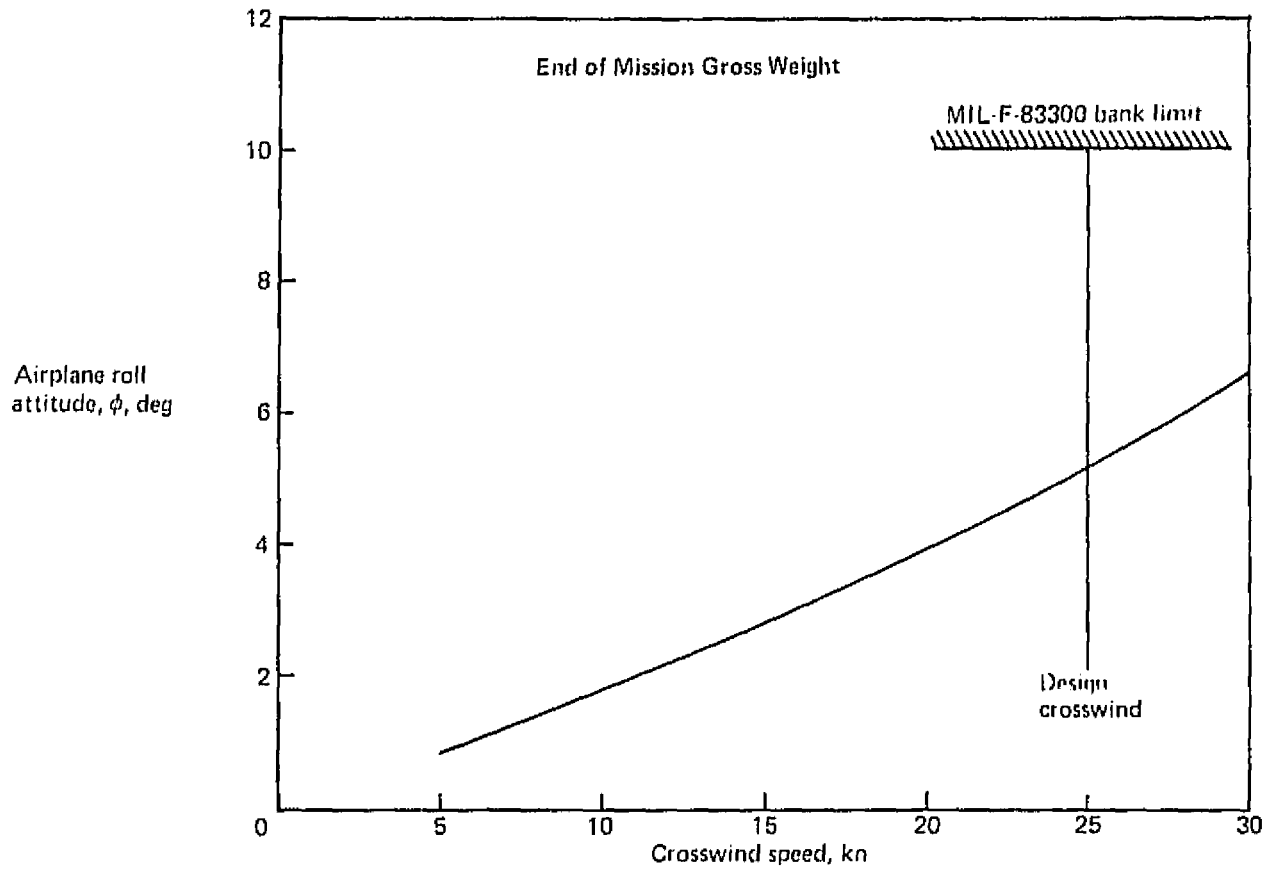

Figure 3.3.9-13.—Hover in a Crosswind (Light Gross Weight)

The transition to and from vertical flight is controlled by thrust vector management. The total airplane thrust vector angle is controlled by rotating the lift/cruise fans. The thrust direction of the nose fan is fixed. Its fan thrust angle is  $75^{\circ}$  from the horizontal. This angle was chosen so that at the liftoff angle-of-attack, for STO, the nose fan thrust will have a positive component along the flight path. Moment balance is maintained by varying the thrust magnitude of the nose fan. This is accomplished by changing blade pitch and power is transferred between the nose fan and the lift cruise fans. During takeoff a constant power setting can be maintained and the thrust will gradually transfer to the cruise system. At the end of transition, the nose fan is very lightly loaded. Most of the power is going to the cruise fans; in this way, the system is conveniently controlled for conversion to conventional flight.

The schedule of nose fan and lift/cruise fan thrust for trim as a function of nacelle angle is shown on Figure 3.3.9-14. During hover the nacelle tilt angle is  $97^{\circ}$  and all three fans are equally loaded. At zero degrees tilt, nacelles horizontal, the nose fan is near zero thrust and the cruise fans are at high thrust. The resultant thrust vector angle for the trimmed system as a function of nacelle tilt angle is shown on Figure 3.3.9-15. These schedules apply at all power levels. The power distribution for balance is a function only of nacelle angle.

The moment producing elements of the V/STOL control system can undergo changes in function during transition. For example, the roll control is achieved, with the nacelles vertical, by modulating the thrust of the lift/cruise fans. With the nacelles horizontal, this same action produces a pure yaw moment. The control system mixes, blade pitch angle, vane deflection, and aerodynamic control deflections as a function of speed and nacelle angle to reduce pure moments from the control inputs.

The vertical tail was sized by a statistical relationship between forward fuselage moment of area and vertical fin moment of area. The data basis is shown in Figure 3.3.9-16. The tail fin area is  $63 \text{ ft}^2$  and the volume coefficient is .08.



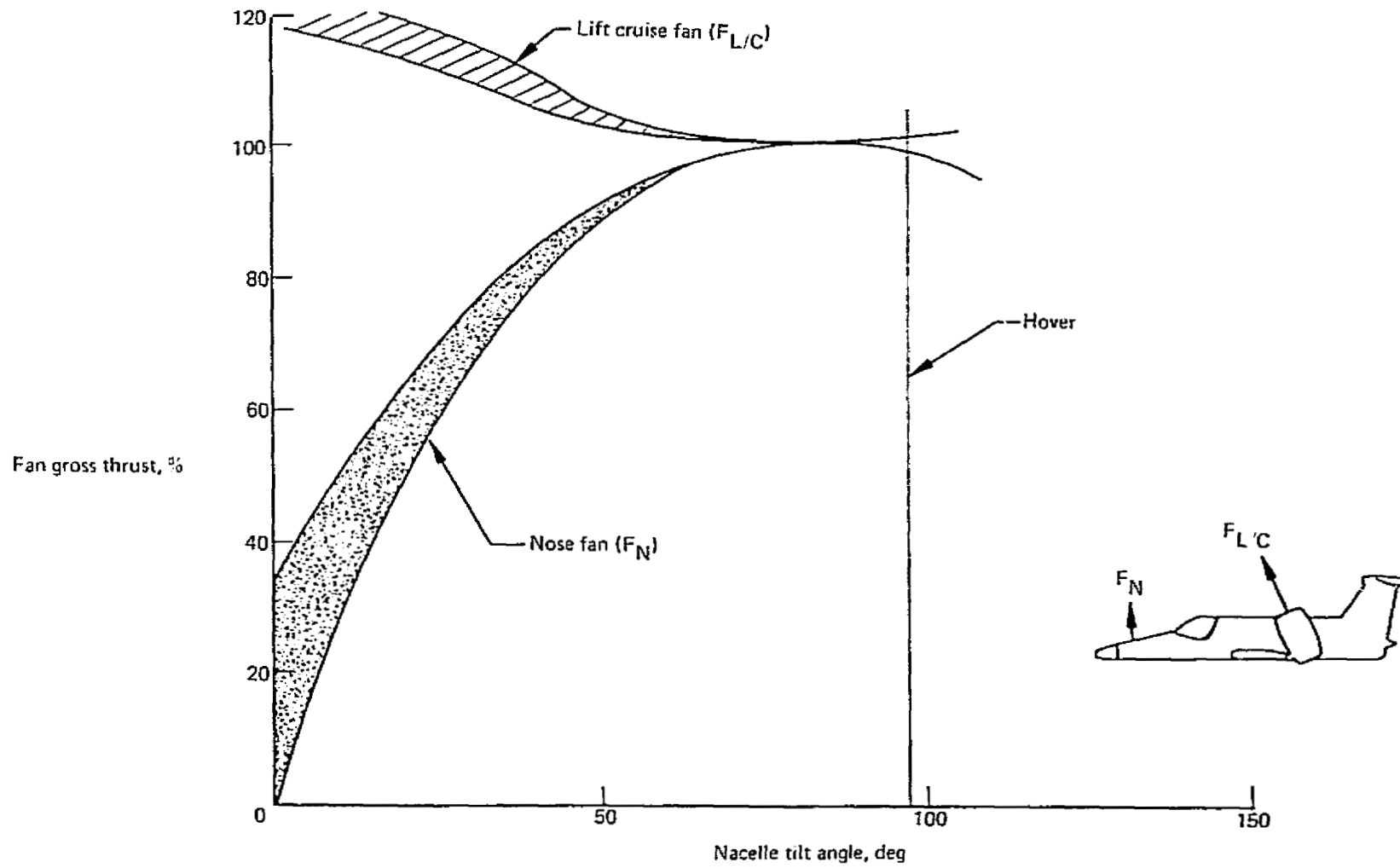

Figure 3.3.9-14.—Thrust Vectoring Trim Schedule, Model 1041-133

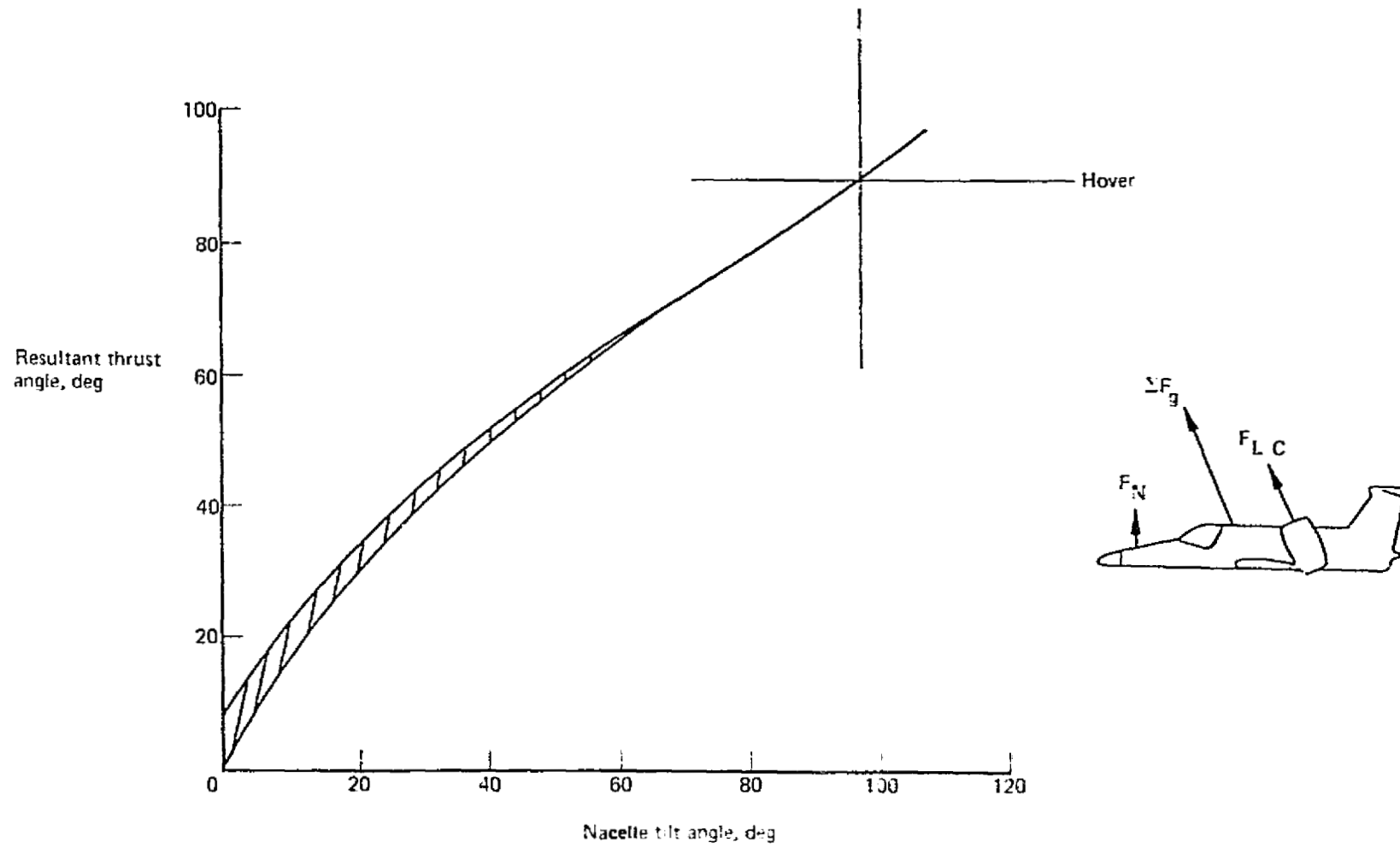

Figure 3.3.9-15.—Thrust Vectoring Trim Schedule, Model 1041-133

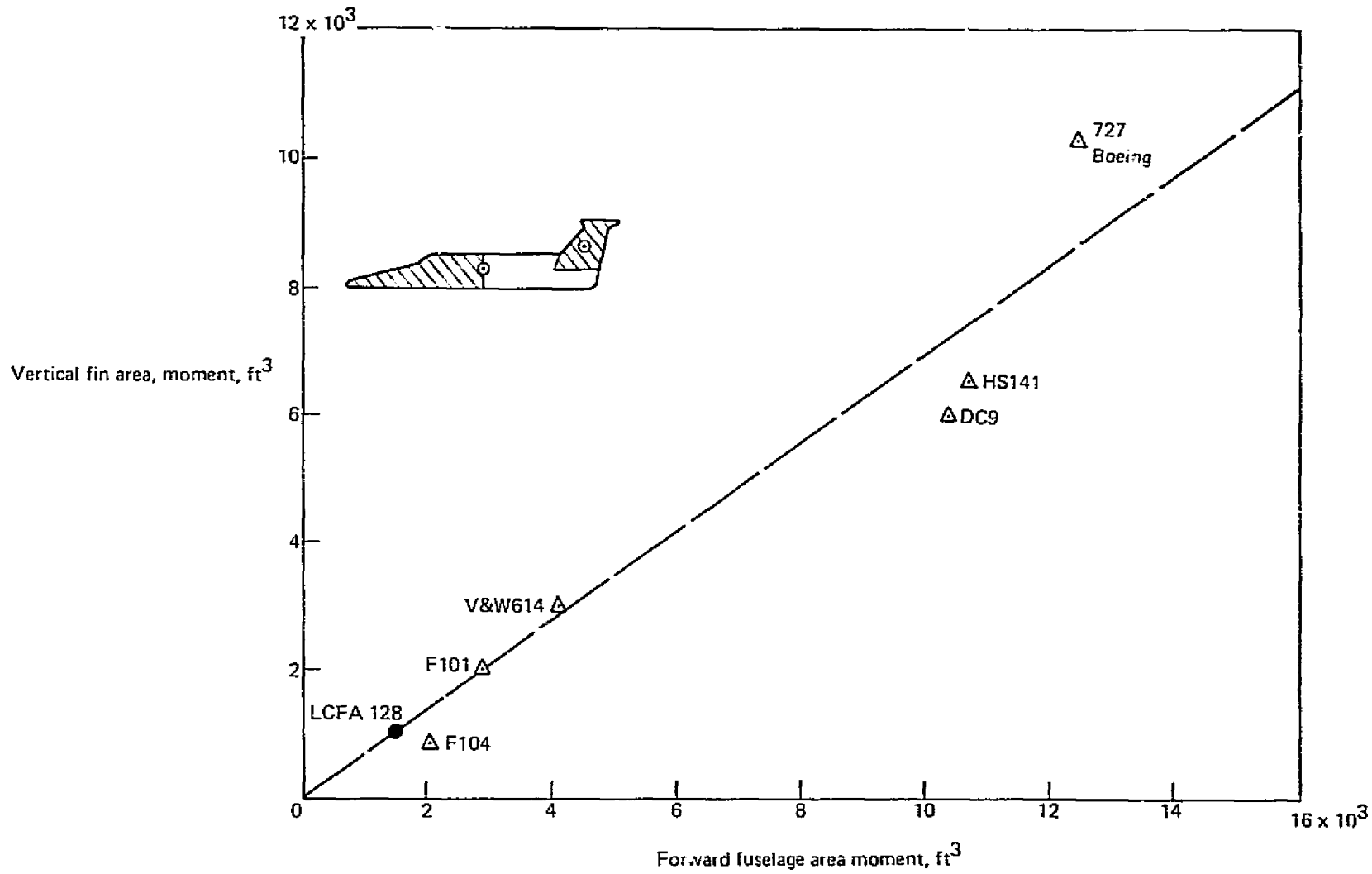

Figure 3.3.9-16.—Static Directional Stability Cruise Vertical Fin Size

The horizontal stabilizer was sized to meet a static longitudinal stability margin of 0.05 at the aft center of gravity; a flap pitching moment trim at maximum lift coefficient and a center of gravity of travel of  $\pm .05\bar{c}$  wing.

These conditions are met by a tail volume coefficient of 0.54 and a nominal center of gravity location at  $0.30\bar{c}$  (shown in Figure 3.3.9-17). The stabilizer panel size is  $64 \text{ ft}^2$ . A stabilizer aspect ratio of 5.0 was chosen to achieve a favorable tail span to nacelle span for effectiveness at high airplane angle of attack.

$$\frac{\partial \epsilon}{\partial \alpha} = 0.5$$

$$C_{mo} = -0.2$$

$$C_{Lmax} = 2.2$$

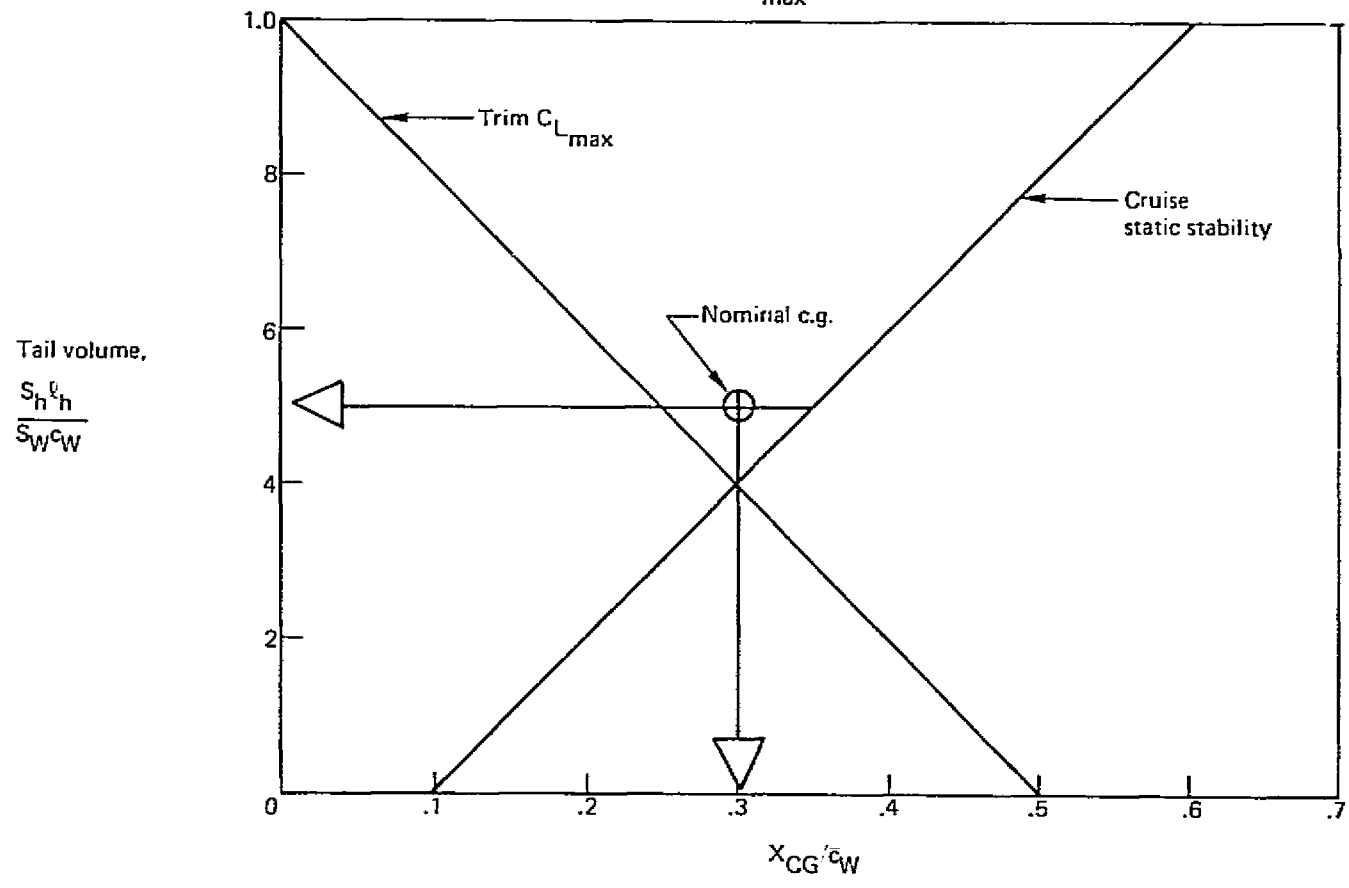

Figure 3.3.9-17.—Horizontal Tail Size

#### 4.0 PART II - LIFT/CRUISE FAN TECHNOLOGY AIRCRAFT

Three separate approaches to the design of an airplane representing the technology of the multi-mission aircraft developed under Part I were taken:

- (a) An all new airplane
- (b) Modification of an existing airplane (T-39A) capable of operation over the same flight envelope as the all new airplane.
- (c) Modification of an existing airplane (T-39A) for low speed operation, approximately 160 KEAS maximum speed capability.

All the designs use the same cruise and lift fan hardware as the operational multi-mission airplane. The turboshaft engine is the XT701 (PD 370-16) essentially the same as that intended for the Army Heavy Lift Helicopter program. The drive system interconnect and the "T" gearbox are all designed for the operational improved engine having 50% more power. The technology airplane drive system will have the advantage of operating in a de-rated mode.

Emphasis on minimum weight is paramount and for a two-engine airplane, the critical design case is performance with one engine out. The research payload is 2500 lbs. and the crew consists of pilot and co-pilot.

The T-39 (Sabreliner) is a fortunate match for an aircraft that can be modified for lift/cruise fan technology development. It is in the department of defense inventory and is a current production airplane.

#### 4.1 ALL NEW AIRCRAFT (Model 1041-134)

Major design guidelines for this airplane are that it must approximate the operational aircraft handling properties, fundamental aerodynamic, and cockpit work station. It must feature high research utility in its performance and exploration margins, and safety. The proposed design satisfies all of these requirements.

##### 4.1.1 Configuration

Fig. 4.1-1 shows the general arrangement of the Model 1041-134. The arrangement has the appearance of a "slimmed down" operational airplane with a reduced wing size. An overlay comparison of the technology and operational airplane is shown in Figure 4.1-2.

For simplicity and low cost, there are no wing folds, wing fuel, nor leading edge devices. Avoiding the use of wing fuel eliminates the need for many access holes, thus saving the weight and cost that structural discontinuity and hole framing introduces. For an airplane relying on powered lift, the avoidance of exotic aerodynamic high lift devices is prudent.

The airplane is designed for a limit load factor of 2.5g and a maximum dynamic pressure (q), of 212 psf. This is equivalent of 250 KEAS and permits Mach 0.8 flight at about 36,000 ft. altitude.

Lift/cruise propulsion pod structural support and arrangement is the same as that for the operational airplane.

The principal features of the Model 1041-134 are:

- o Design weight of 20,000 lbs.
- o Aluminum airframe
- o 200 ft<sup>2</sup> wing
- o No cabin pressurization
- o 62 inch diameter variable pitch fans
- o Allison XT701 engines
- o Flying tail
- o Body fuel in foamed bladder

Wing area = 200 ft<sup>2</sup>  
Aspect ratio = 3.64  
Taper ratio = 0.5  
Thickness ratio = 0.15

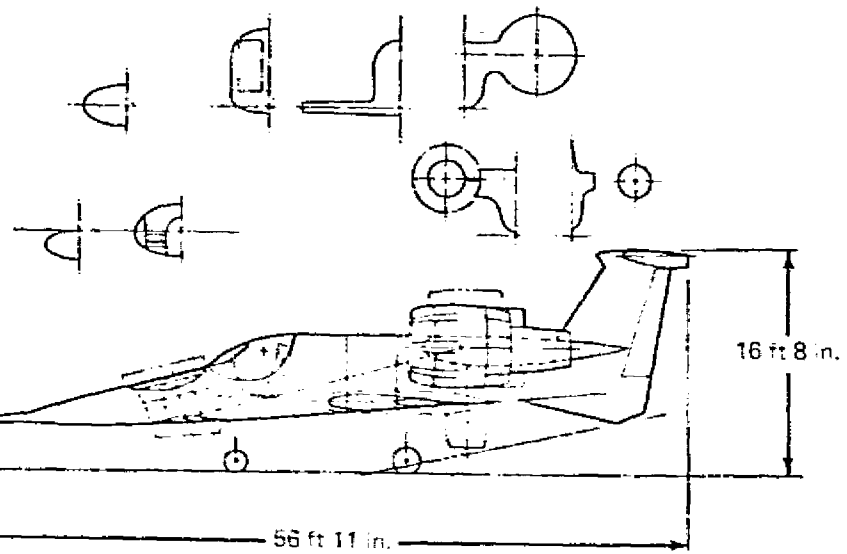
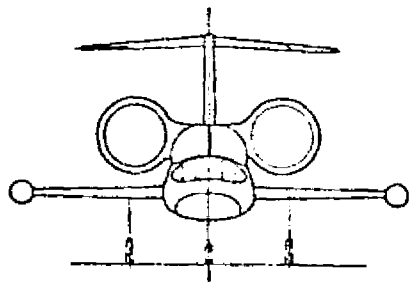
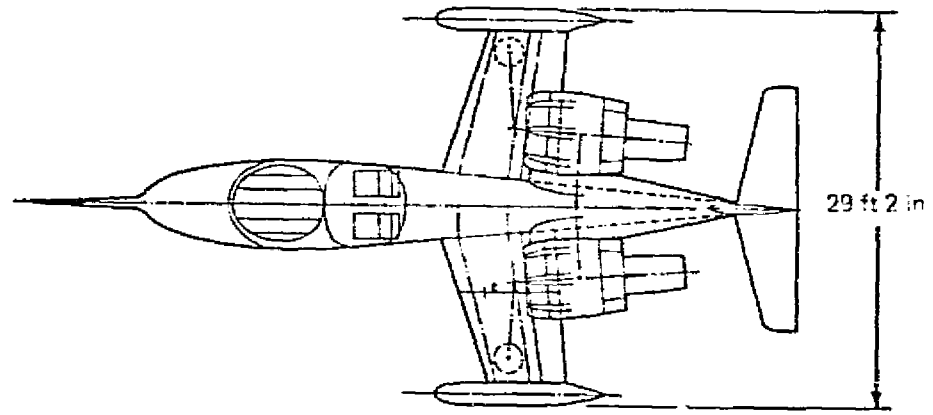

Figure 4.1-1.-General Arrangement, Model 1041-133



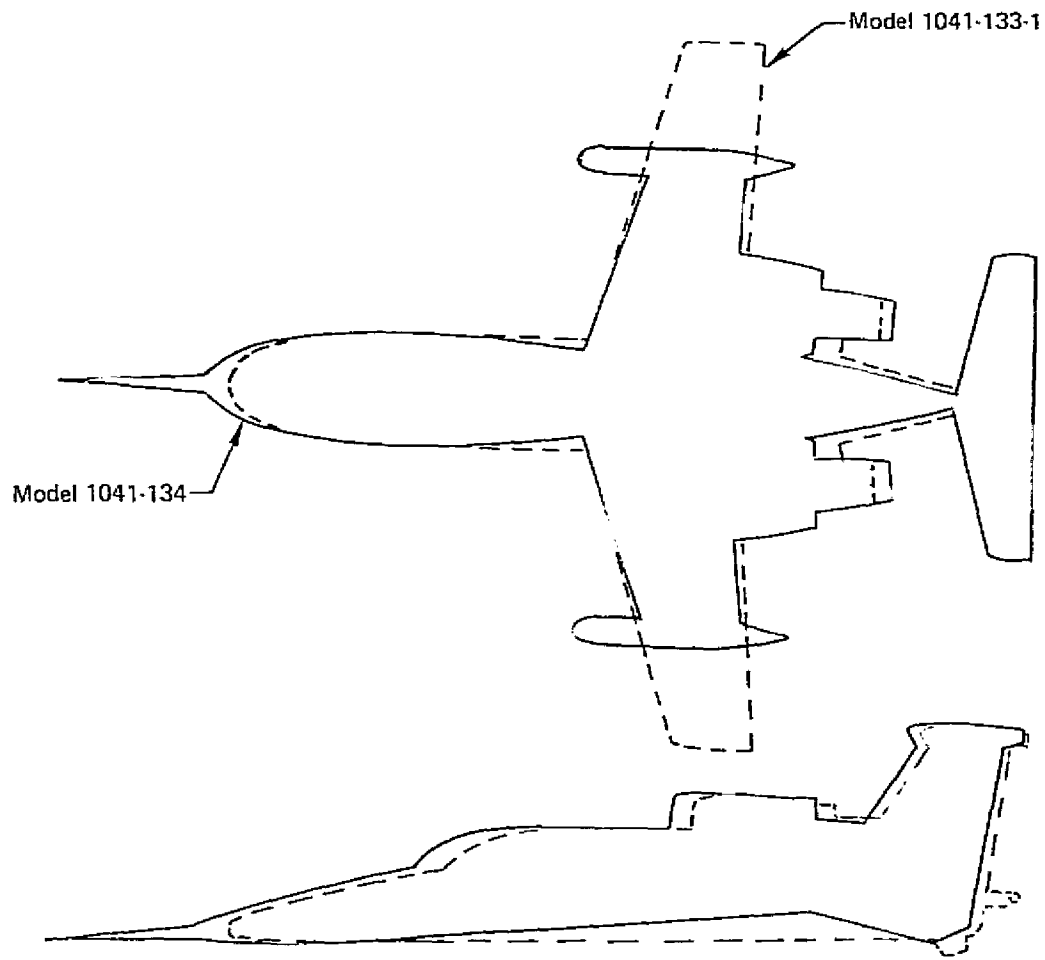

Figure 4.1-2.-Overlay Comparison

- o 3000 psi dual hydraulic system
- o Fly-by-wire flight controls using dual, redundant command augmentation system
- o Variable geometry inlet
- o Variable area nozzle
- o Water injection for emergency single engine flight
- o Ejection is through the canopy. No pressurization, low q flight, permit light weight canopy enclosure that permits this emergency ejection approach
- o No air-conditioning or anti-icing

#### 4.1.2 Propulsion

The propulsion system for the technology airplane is identical to the operational airplane with the exception of the gas generator. The engine used in the technology airplane is a modified version of the current T701. Modifications will be made to the LP turbine and a water/alcohol injection system will be employed to achieve performance given in Table 4.1-1. The water/alcohol injection system will be a modification of the fully developed system used on the Allison T56 turboprop engine. To insure operational capability, the system will run continuously during the hover mode by recirculating the mixture back to the tank. During engine out operation a valve will open delivering the water/alcohol mixture to the operating engine.

#### 4.1.3 Aerodynamics

The lift and drag properties of the -134 are given in Table 4.1.3-1 and Figures 4.1.3-1 to 4.1.3-7. The table lists the zero lift drag breakdown. Figure 4.1.3-1 gives the drag due to lift. The factor used in calculating the roughness and excrescence is in Figure 4.1.3-2 and the interference drag between the cruise nacelle and the fuselage is in Figure 4.1.3-3. The complete cruise drag polar is in Figure 4.1.3-4 and the V/STOL mode polar with the nacelles at  $45^{\circ}$  is in Figure 4.1.3-5.

The lift, power off, is Figure 4.1.3-6 and the effect of power in the V/STOL mode with the nacelles at  $50^{\circ}$  is in Figure 4.1.3-7.

*Table 4.1-1.—Installed Static Performance on Technology Aircraft*

Condition	FPR	Thrust, lb	SFC, lb/lb hr
STOL, 2 engines/2 fans	1.19	21 890	0.271
VTOL, 2 engines/3 fans	1.11	27 680	0.243
Contingency, 1 engine/3 fans (water/alcohol)	1.12	21 000	0.228

\*Sea level, 90° F, day

ORIGINAL PAGE IS  
OF POOR QUALITY

Table 4.1.3-1.--LCFA 1041-134 Zero Lift Drag Breakdown

ALT = 35,000 FT  
 SREF = 200 FT<sup>2</sup>  
 AWET = 1,517 FT<sup>2</sup>  
 M = .6

<u>COMPONENT</u>	<u>C<sub>D</sub></u>	
WING	.00672	
FUSELAGE	.00529	
CANOPY	.00135	
HORIZ TAIL	.00278	
VERT TAIL	.00142	
VENT FIN	.00036	
NACELLES (ISOLATED)	.00446	
NACELLE PYLONS	.00118	
TIP TANKS (FERRY MISSION)	.00378	
NOSE BOOM	.00019	
NACELLE-FUS INTERF.	.00315	
WING BODY INTERF.	.00035	
VERT-HORIZ INTERF.	.00005	
EXCRESCENCE	.00600	.00600 EXCR
CAMBER	.00102	.00102 CAMBER
TOTAL	.0381	

(C<sub>FE</sub> = .0050)

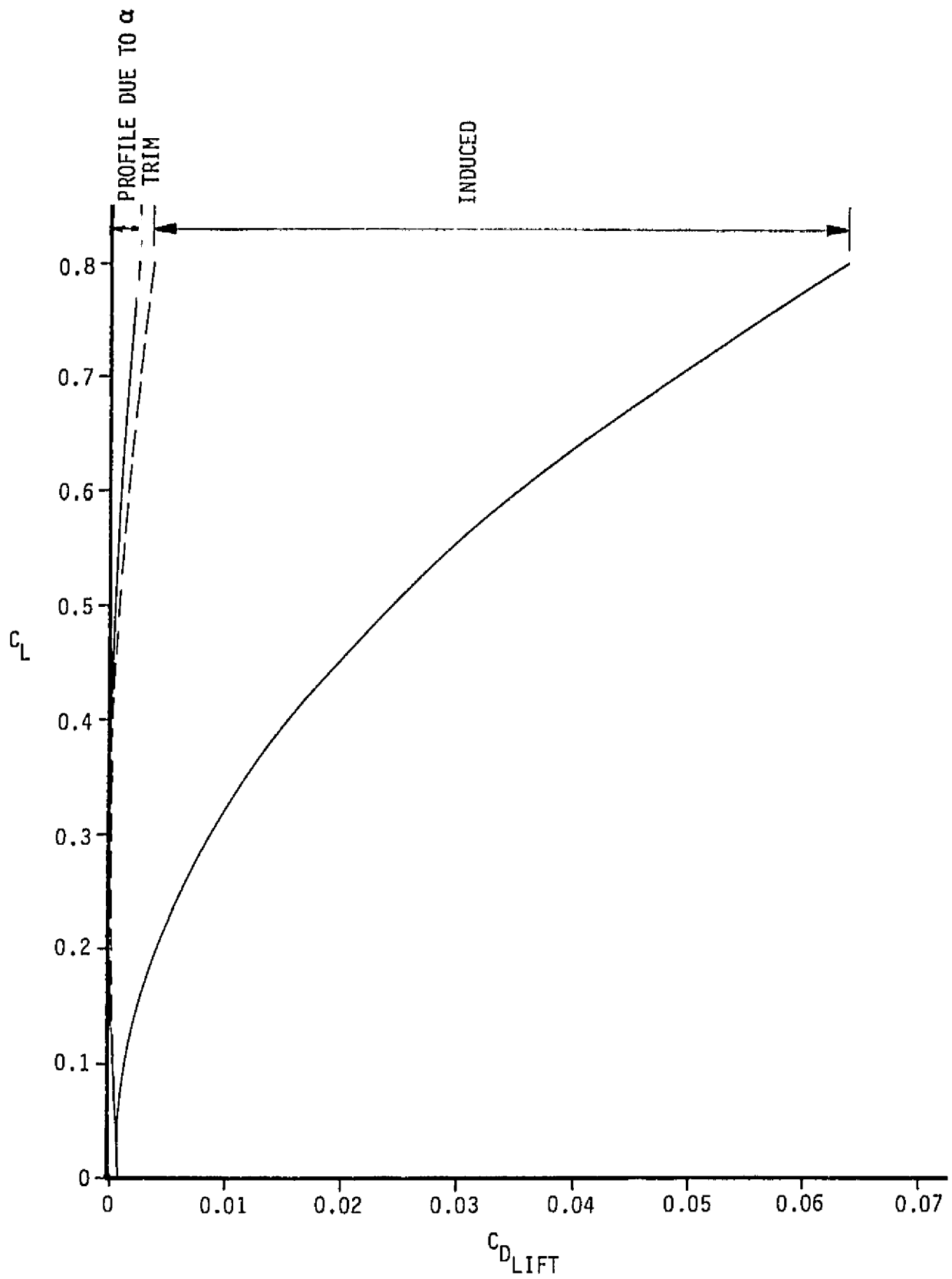

Figure 4.1.3-1.--Drag Due to Lift LCFA 1041-134 (All New AP) Mach = 0.6

$$\Delta C_{DP_{EXCRES.}} = K_E C_{DP_{MIN}}$$

WHERE:  $C_{DP_{MIN}}$  IS MINIMUM PARASITE  
DRAG EXCLUDING ROUGHNESS  
AND EXCRESCENCE DRAG.

NOTE: AIR CONDITIONING  
DRAG INCLUDED

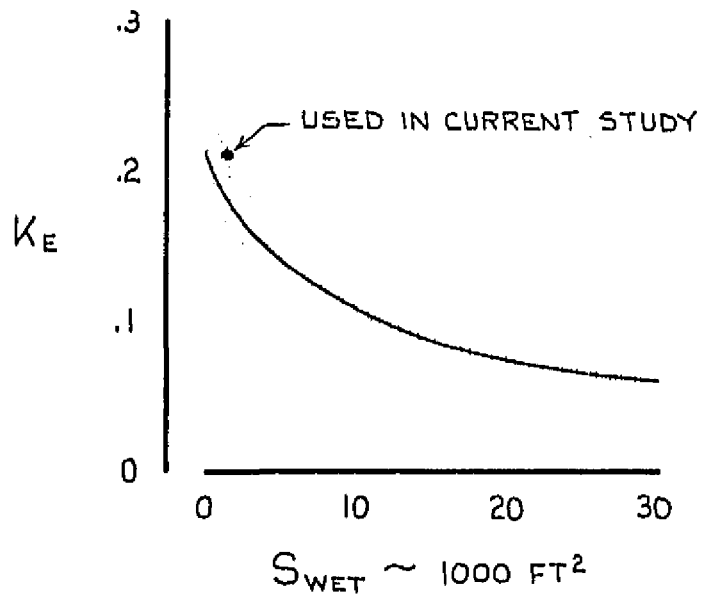
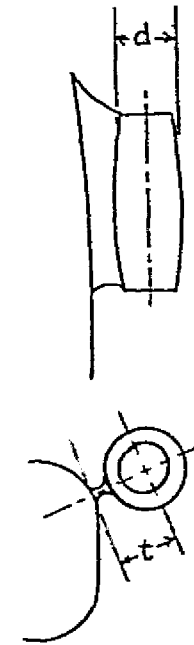
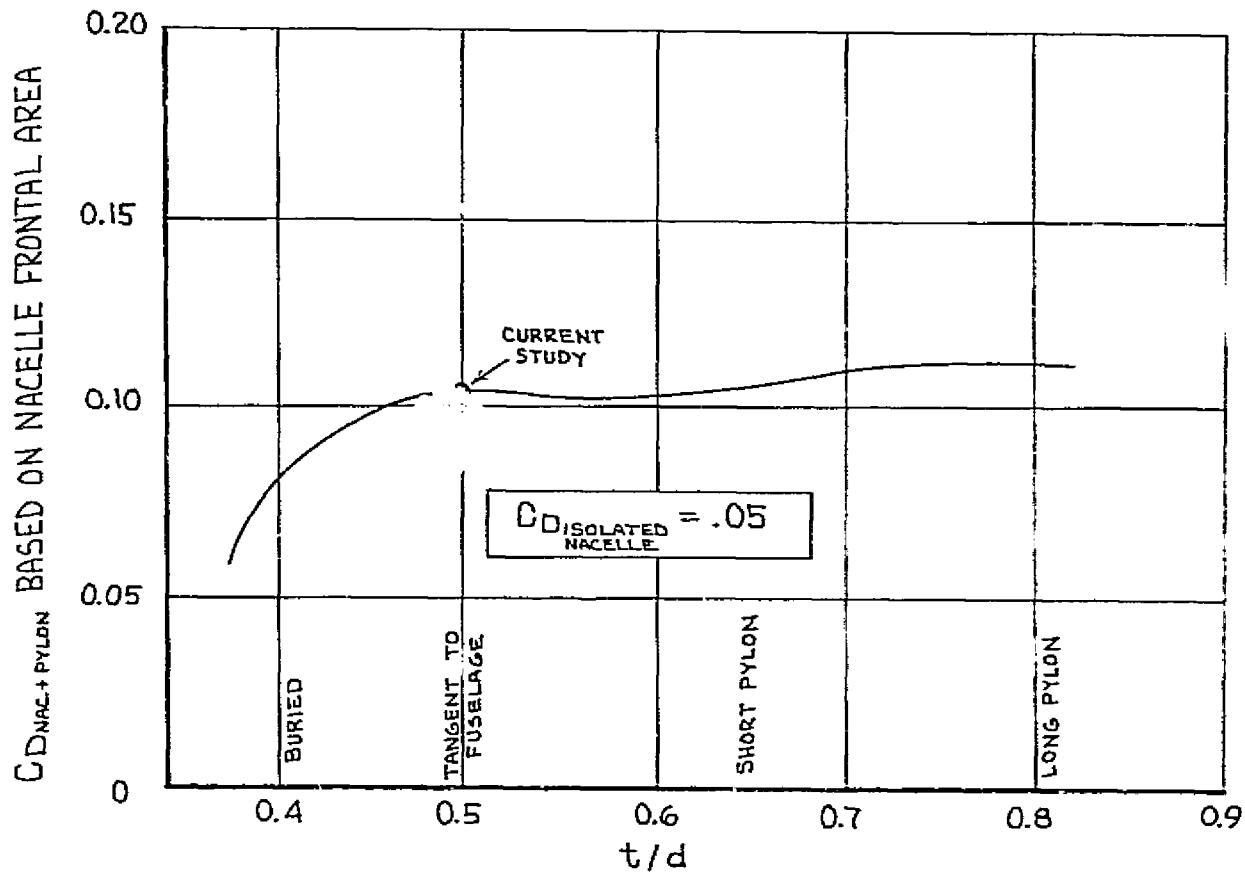

Figure 4.1.3-2.-Roughness Plus Excrescence Drag Factor



NOTES: 1. DRAG OF THE NACELLE INCLUDES INTERFERENCE.

2. REF: ROSKAM, J., METHODS FOR ESTIMATING DRAG POLARS OF SUBSONIC AIRPLANES.

Figure 4.1.3-3.—Drag Due to a Jet Engine Nacelle Attached to a Fuselage as a Function of Pylon Length

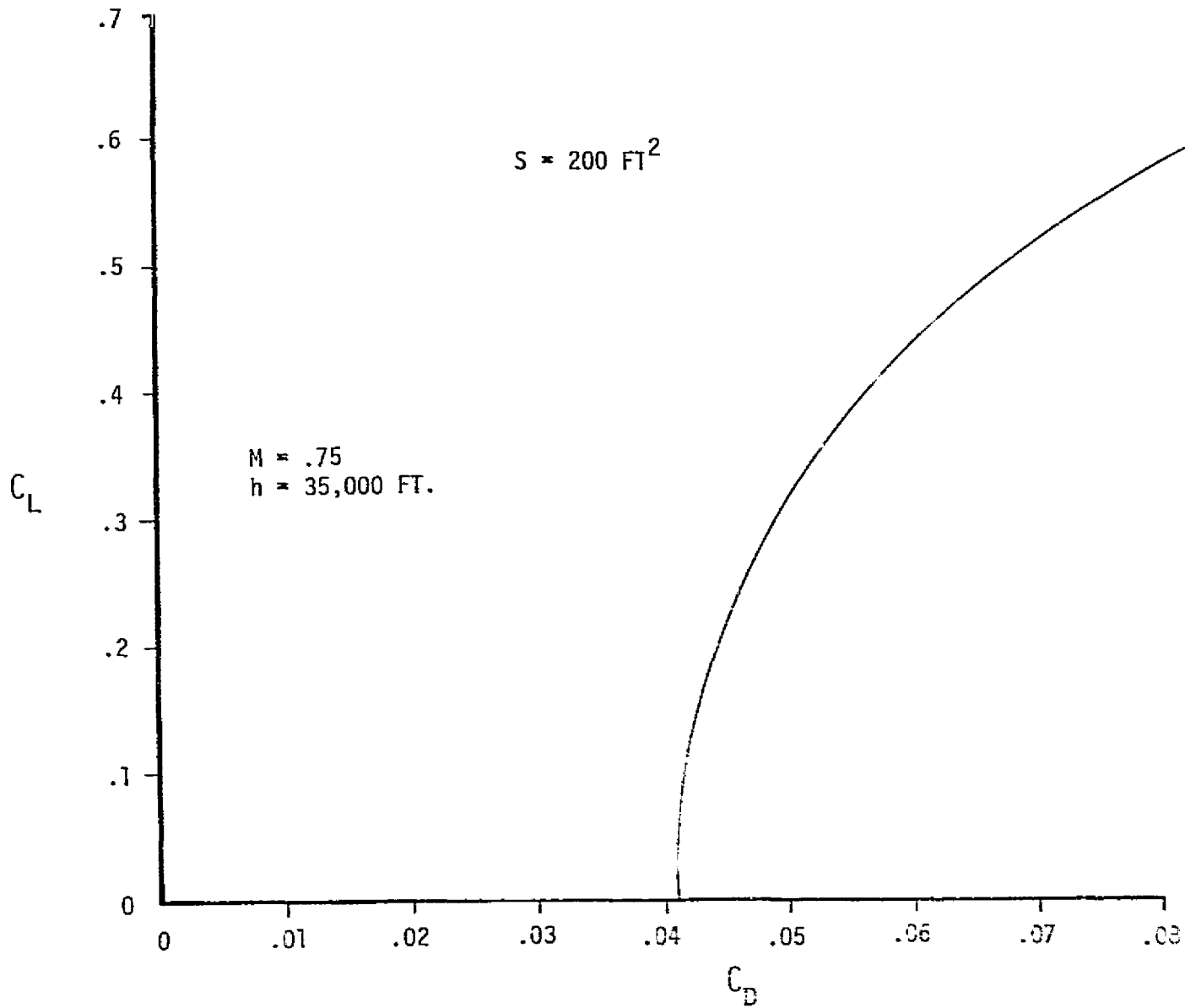

Figure 4.1.3-4.-Drag Polar LCFA 1041-134-All New A P



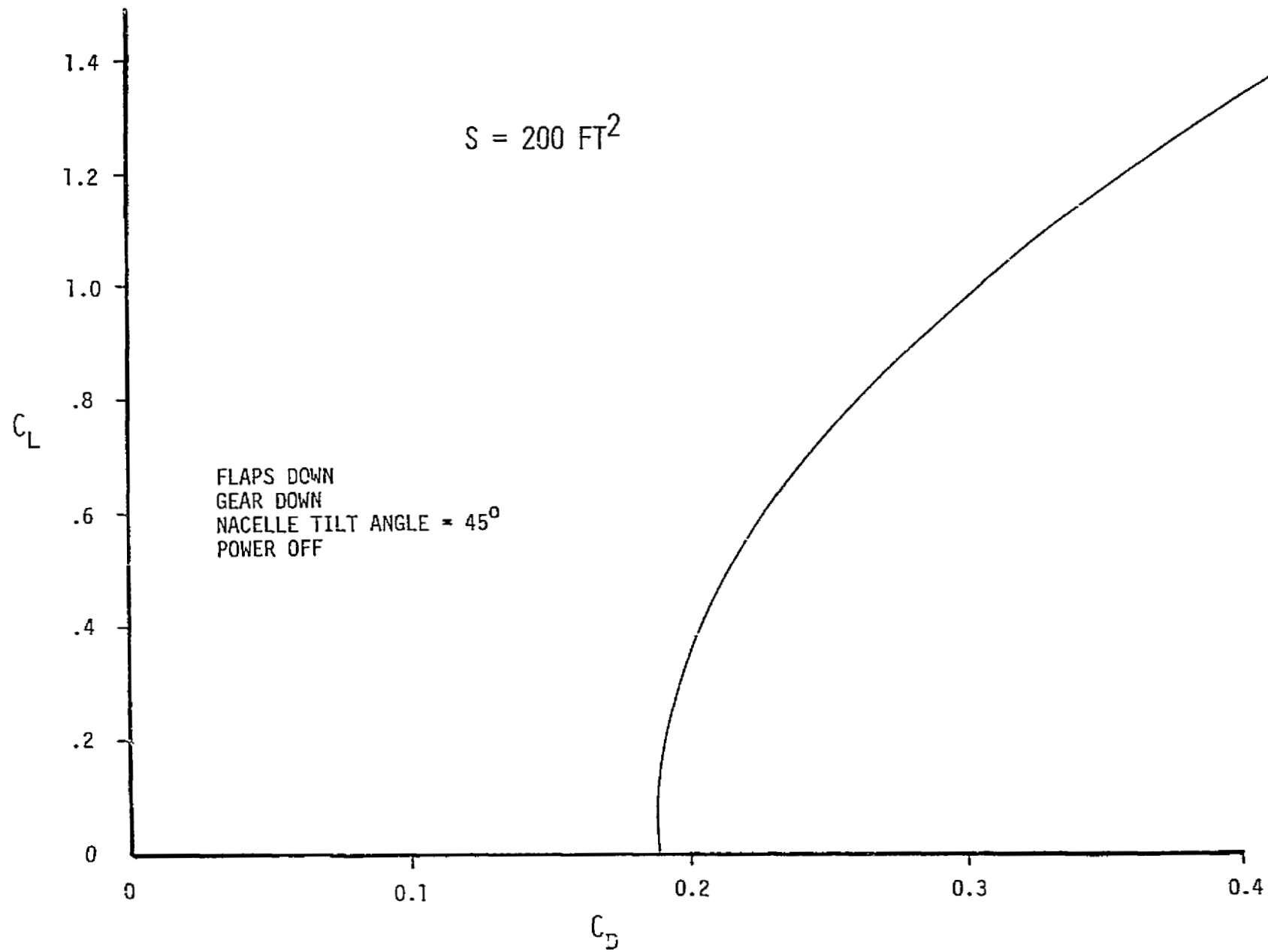

Figure 4.1.3-5.—Low-Speed Drag Polar LCFA 1041-134—All New A/P

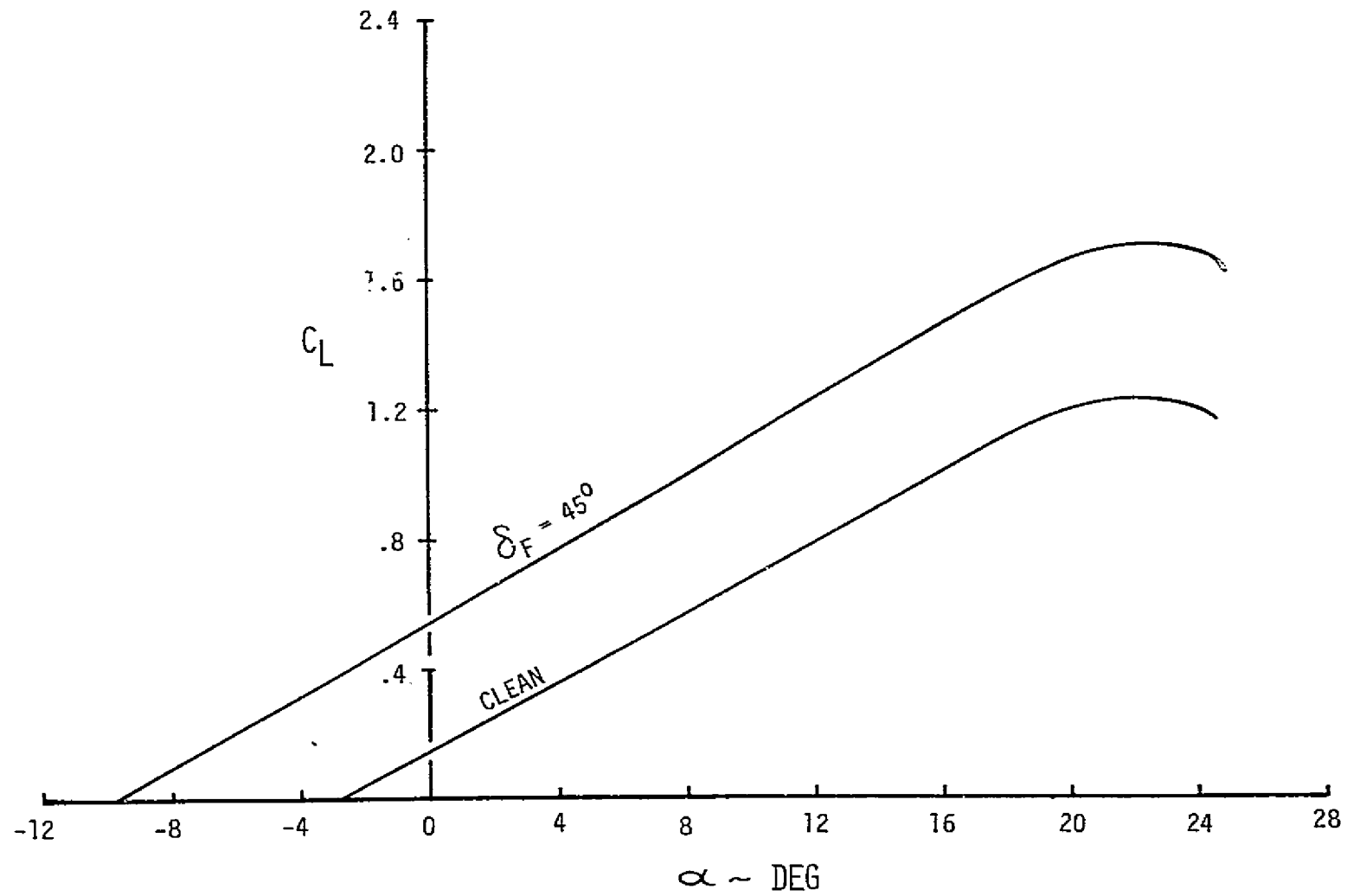

Figure 4.1.3-6.—Aerodynamic Lift Power Off LCFA 1041-134 All New A/P

INTERMEDIATE THRUST  
SEA LEVEL STD DAY  
FLAPS DOWN  
 $\lambda = 50^\circ$   
 $V = 55$  KTS  
(NO ALLOWANCE FOR INDUCED LIFT)

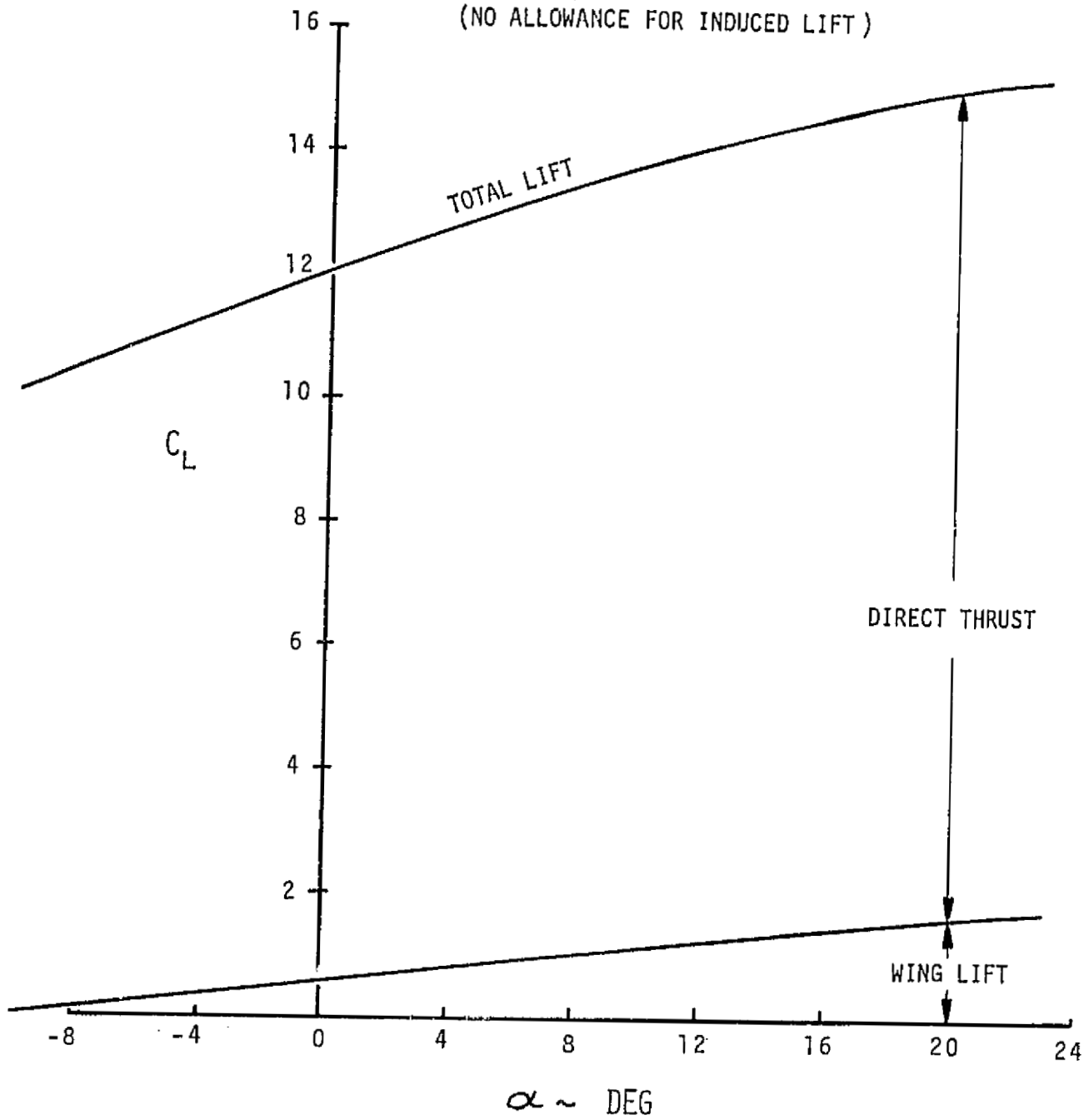

Figure 4.1.3-7.-Power-on Lift LCFA 1041-134

#### 4.1.4 Flight Controls

The flight control system for the technology airplane is the prototype for the operational airplane. The fly-by-wire system will be developed and refined in this airplane. The control system description of the operational airplane (Section 3.3.9) applies to the technology airplane.

The airplane moment of inertias in roll and yaw are greater than the operational airplane because of the wing tip tanks. The thrust modulation needed to meet roll control levels for hover are larger because attitude control scales with moment of inertia. The increase in thrust modulation is available at no penalty because the fans of the technology airplane are operated well below design thrust levels. The control available is tabulated on Table 4.1.4-1. This VTOL control capability, combined with the variable stability features achievable with a fly-by-wire system, gives the technology airplane excellent potential for handling qualities research. The flight control characteristics of the technology airplane will have the flexibility to simulate a range of operational properties. The desirable operational characteristics can be established by flight experience.

The control response of the system is significantly better than the guidelines minimum. The response to maximum control commands, far outside of design requirements, is less than 0.2 seconds. The response for the pitch, roll and height commands are based on blade angle changes at essentially constant fan speed. Figure 4.1.4-1 shows the response time variations with control input size. The time response for a 100% of design level roll control is 0.10 seconds using a system mechanized with a blade rate of 100 deg/sec. The yaw control response is based on the deflection rate of vanes in the slipstream of the fans with similar response characteristics. Height control exercises the system more than attitude control. A "fly up" command requires a change in power to achieve an increase in fan thrust. The response of the system is a function of both blade angle changes and engine power changes. An overall response time of 0.10 seconds is available.

*Table 4.1.4-1.-Technology Demonstration Hover Control Power, Model 1041-134*

Control function	Design guideline requirement	System capability
Roll	0.90 rad/sec <sup>2</sup>	1.80 rad/sec <sup>2</sup>
Pitch	0.50 rad/sec <sup>2</sup>	1.40 rad/sec <sup>2</sup>
Yaw	0.30 rad/sec <sup>2</sup>	0.50 rad/sec <sup>2</sup>
Height	0.05 g	0.22 g

**ORIGINAL PAGE IS  
OF POOR QUALITY**

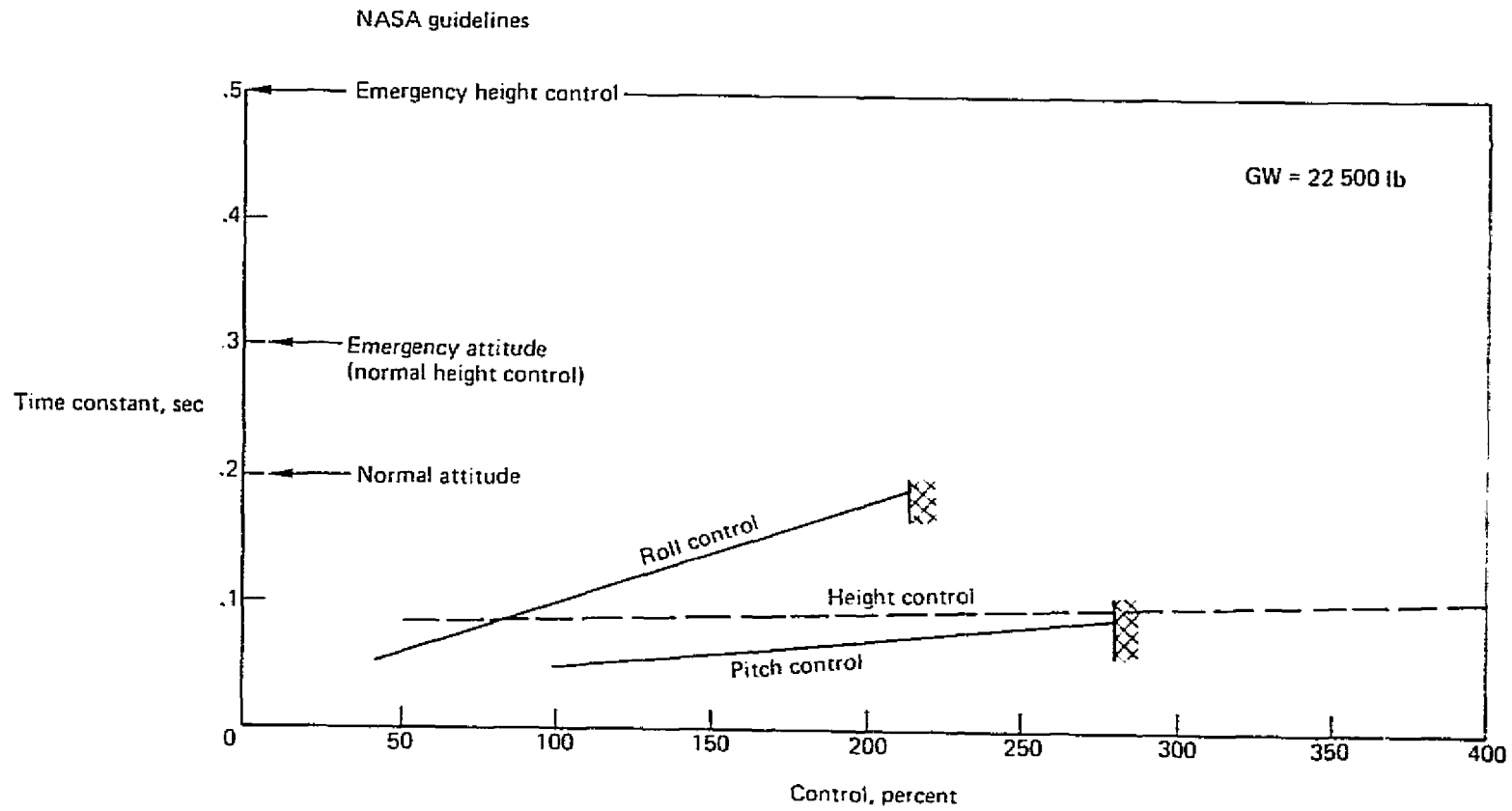

Figure 4.1.4-1.—Model 1041-134 Control Response Time, G.W. = 22,500 lb

#### 4.1.5 Aircraft Systems

The aircraft systems in the technology airplane will be designed primarily to prototype the Model 1041-133 propulsion and flight control systems. Other systems will be capable of meeting the demonstrator operational requirements with the necessary levels of performance and safety.

The accessory power package will be similar to the 1041-133 with the exception that the two 75 KVA generators will be replaced by two 30 KVA generators and the air compressor will be deleted. Performance will be based on the following power extraction:

<u>Condition</u>	<u>Shaft/Horsepower Extraction</u>
Normal	100
Emergency	23
Design	450

#### 4.1.6 Weight and Balance

The weight statement of the new technology airplane is presented in Table 4.1.6-1. The propulsion weight is the significant contributor to an operating weight of 16,400 lbs. The research payload is 2500 lbs. with 240 lb. water/alcohol mixture for water injection during hot day emergency conditions; the mission weight less fuel is 19,140 lbs.

The special features which are directly related to V/STOL capability include the lift/cruise engine pod rotation weight which is 370 lbs. The forward fan installation weight is 350 lbs. and the transmission system increment is 2600 lbs.

The lift/cruise fan and transmission system weights have been coordinated with and obtained from the propulsion system component manufacturers (see Table 4.1.6-2). These data have been integrated into the operating weight of the technology airplanes.

The loading diagram, Figure 4.1.6-1, for the all new technology airplane shows the relationship of operating weight c.g. and the location of payload and fuel. The loading is typical of each of the technology airplanes. The diagram shows the payload loads forward, while the fuel load vector is located to produce minimal change in the operational c.g.

Table 4.1.6-1.-Technology Airplane Weight Statement NASA/Navy V/STOL-Part II

V/STOL MODEL 1041 - 174	WEIGHT (LB.)	LOAD CG (IN.)	
WINGS	930	410	
HORIZONTAL TAIL	360	632	
VERTICAL TAIL	110	600	
BODY	1850	370	
MAIN GEAR	650	110	
NOSE GEAR	110	265	
NOSE/ENGINE SECTION	1600	410	Including exhaust & deflected
<b>STRUCTURE</b>	<b>(5650)</b>	<b>(1177.7)</b>	
FANS	970	370	
ENGINE	3100	500	Including front fuselage
ENGINE ACCESSORIES	100	265	
FUEL SYSTEM	190	580	
ENGINE CONTROLS	80	170	
STARTING SYSTEM	80	190	
DRIVE SYSTEM	2600	105	
H <sub>2</sub> O ALIMENTATION	130	595	
<b>PROPULSION</b>	<b>(5550)</b>	<b>(1112.3)</b>	
INSTRUMENTS & NAV EQUIP	250	320	
FLIGHT CONTROLS	750	420	
HYDRAULIC/PNEUMATIC	300	370	
ELECTRICAL	410	320	
AVIONICS	210	272	
ARMAMENT			
FURNISHINGS & EQUIP	500	300	
AIR COND & ANTI-ICING	150	354	
<b>FIXED EQUIPMENT</b>	<b>(2600)</b>	<b>(747.7)</b>	
<b>WEIGHT EMPTY</b>	<b>15800</b>	<b>417.9</b>	
CREW	360	290	
CREW PROVISIONS	40	290	
OIL & TRAPPED OIL	90	130	
UNAVAILABLE FUEL	110	387	
<b>NON-EXP USEFUL LOAD</b>	<b>(600)</b>	<b>(328.8)</b>	
<b>OPERATING WEIGHT</b>	<b>16400</b>	<b>414.7</b>	
PAYLOAD (INCL EXP PEN AIDS)	2500	300	
H <sub>2</sub> O & ALCOHOL	210	595	
<b>MISSION WEIGHT LESS FUEL</b>	<b>19140</b>	<b>398.9</b>	

LIMAC = 364.4  
MAC = 90.0

ORIGINAL PAGE IS  
OF POOR QUALITY



Table 4.1.6-2.-Lift/Cruise Fan and Transmission System Weight, lb, Technology Airplane

<u>COMPONENT</u>	<u>CONTRACTOR</u>	<u>WEIGHT</u>
LIFT/CRUISE FANS	HAMILTON-STANDARD	642
LIFT FAN	" "	<u>321</u>
TOTAL FANS		963
CONTROLS - LIFT CRUISE	" "	22
- LIFT	" "	11
GEAR TRAIN ASSY - LIFT CRUISE	" "	333
GEAR TRAIN ASSY - LIFT	" "	412
FAN CASE - LIFT	" "	267
HEAT EXCHANGER	" "	30
COMBINER BOX (T BOX)	BOEING VERTOL	593
DISCONNECT CLUTCH	"	57
DRIVE SHAFTING	BOEING SEATTLE	222
DRIVE SYSTEM/AIRFRAME INTERFACE	BCAC	<u>123</u>
TOTAL TRANSMISSION		2600

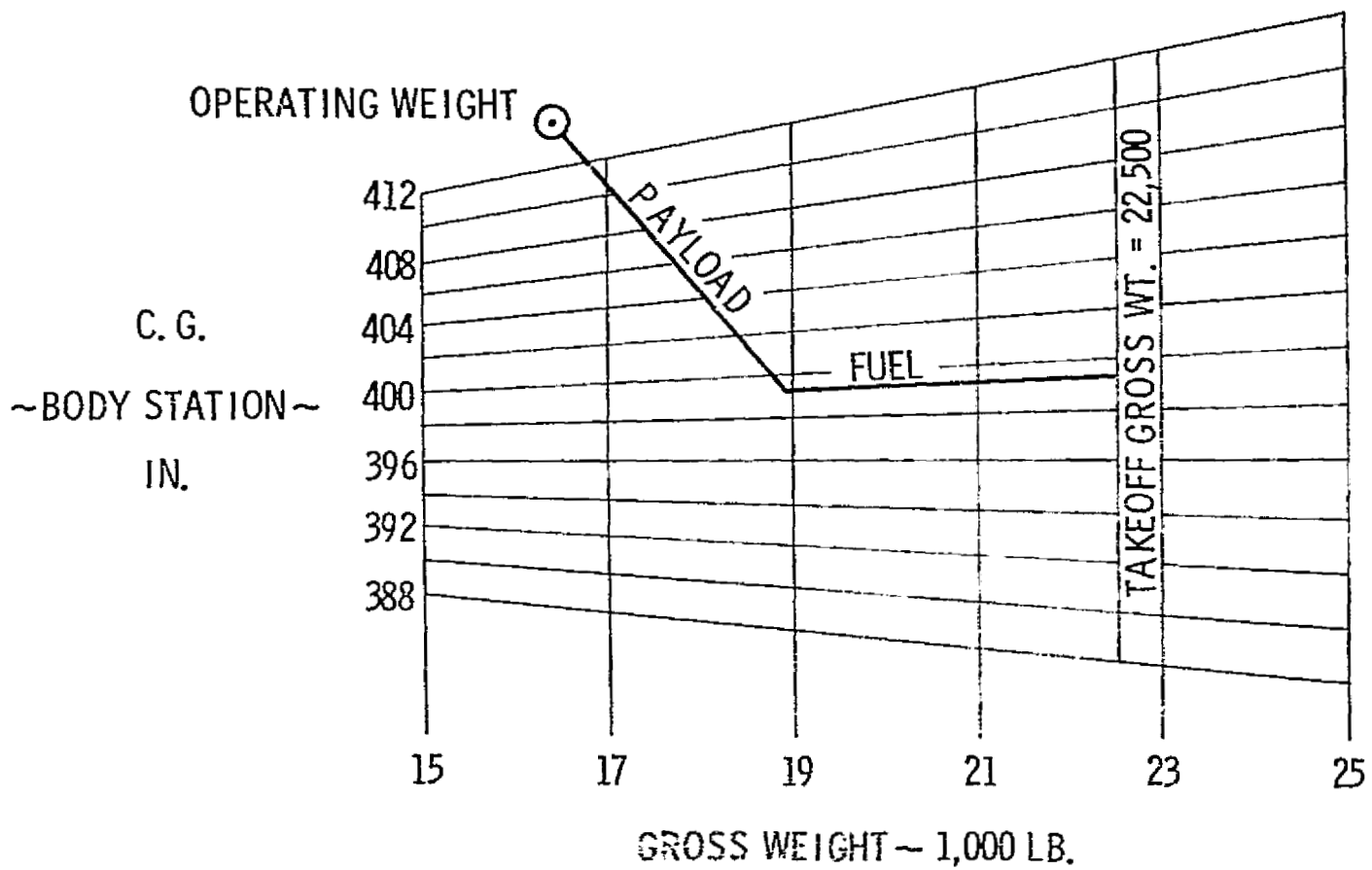

Figure 4.1.6-1.—Balance Diagram Net Technology Airplane

#### 4.1.7 Performance - All New Airplane, 1041-134

The missions used to estimate fuel requirements are shown in Figure 4.1.7-1. Eleven circuits from an initial STO and 5 from a VTO were used as the fuel measure. A ferry mission using the rules shown in Figure 4.1.7-2 was also calculated.

The takeoff performance, ground roll as a function of liftoff speed, is presented in Figure 4.1.7-3. The liftoff speed is 1.2 X stall speed and no credit is taken for induced aerodynamic lift or ground effects. The airplane is assumed to accelerate with the nose fan in flat pitch. At liftoff the nose fan pitch is set to the value required for propulsive moment balance for the amount of engine tilt being used. The lift/cruise fans are held at constant angle during acceleration and liftoff.

The landing performance approach speed vs. ground roll, is shown in Figure 4.1.7-4. The approach speed is 1.2 X stall speed and no credit is taken for induced aerodynamic effects. Thrust reversal is not used.

Emergency vertical landing can be accomplished at a GW of 20,400 lbs. at a thrust weight ratio of 1.03. At higher gross weights a short landing can be accomplished.

Five VTO mission circuits can be done with 1300 lbs. of fuel. The mission takeoff weight is 20,440 lbs. which is equal to the single engine emergency landing weight at  $F/W = 1.03$ . By trading payload for fuel or accepting a limited hovering envelope at higher gross weight a longer VTO mission can be had. The 11 STO circuits can be made from a gross weight of 21,200 lbs. The available thrust, both engine operating, is 27,680 lbs. The STO missions are not limiting.

A ferry range of 820 n.mi. is possible at a gross weight of 25,000 lbs. The thrust weight ratio is still greater than one.

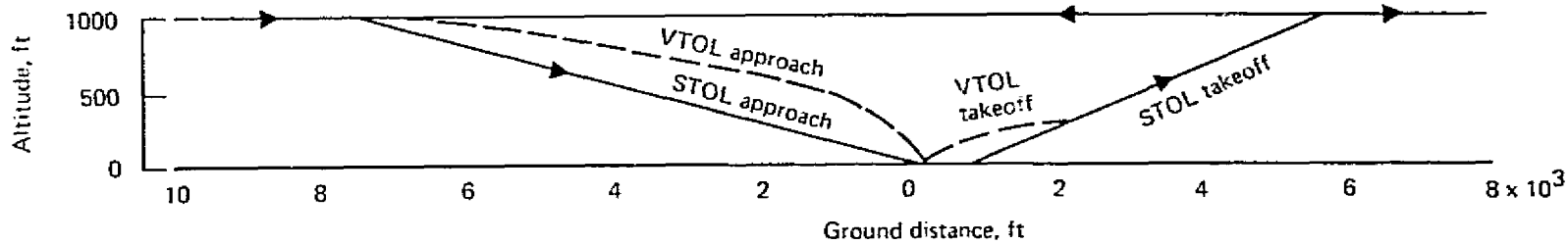
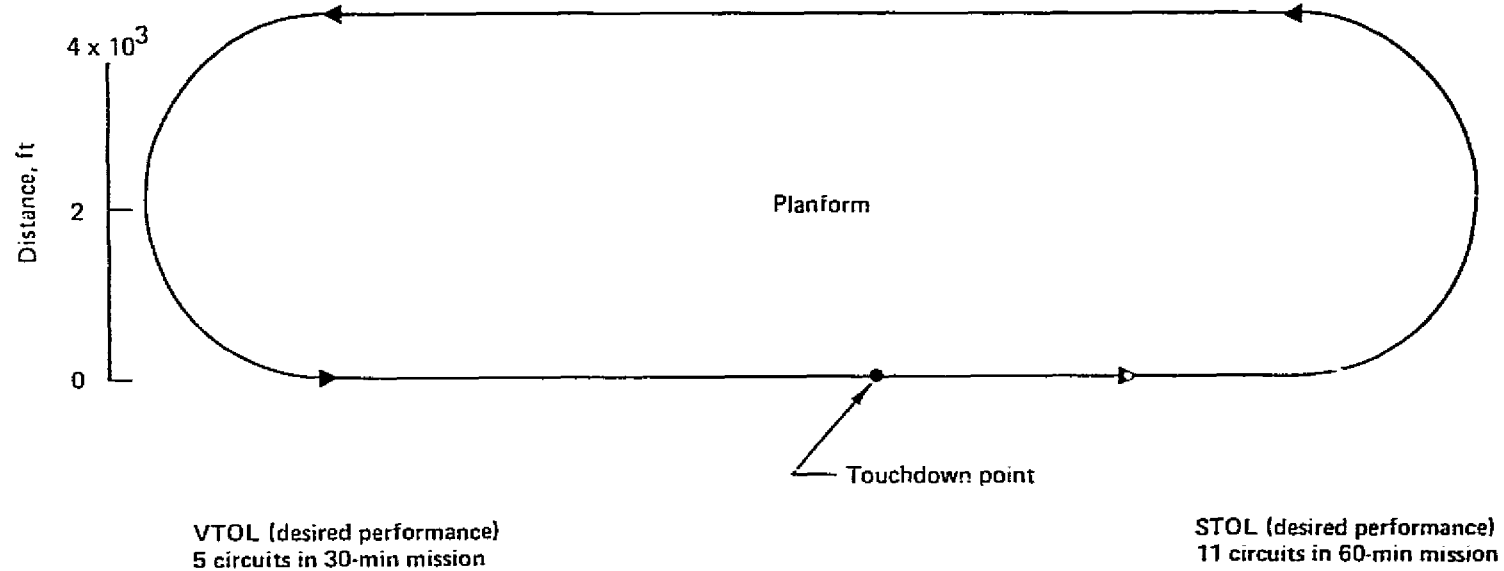
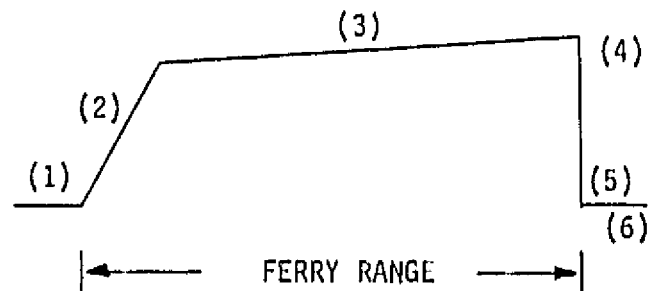

Figure 4.1.7-1.-LCFA Technology Airplanes, Typical Terminal Area Test Missions



- (1) Warm-Up, Takeoff, Accel. to Climb Speed - 2.5 minutes at intermediate thrust. Installed sea level static conditions.
- (2) Climb - To best cruise altitude and velocity at intermediate thrust.
- (3) Cruise - To maximum range at best cruise altitude and velocity Breguet range.
- (4) Descent - To sea level. No fuel, time or distance.
- (5) Landing Allowance and Reserves - Fuel for:
  - (a) 20 minutes loiter at best endurance speed at sea level.
  - (b) 5% total initial fuel
- (6) Taxi-In - From reserves

*Figure 4.1.7-2.-LCFA Technology Airplanes Ferry Mission Performance Rules*

Sea level 90° F  
GW = 22 500 lb

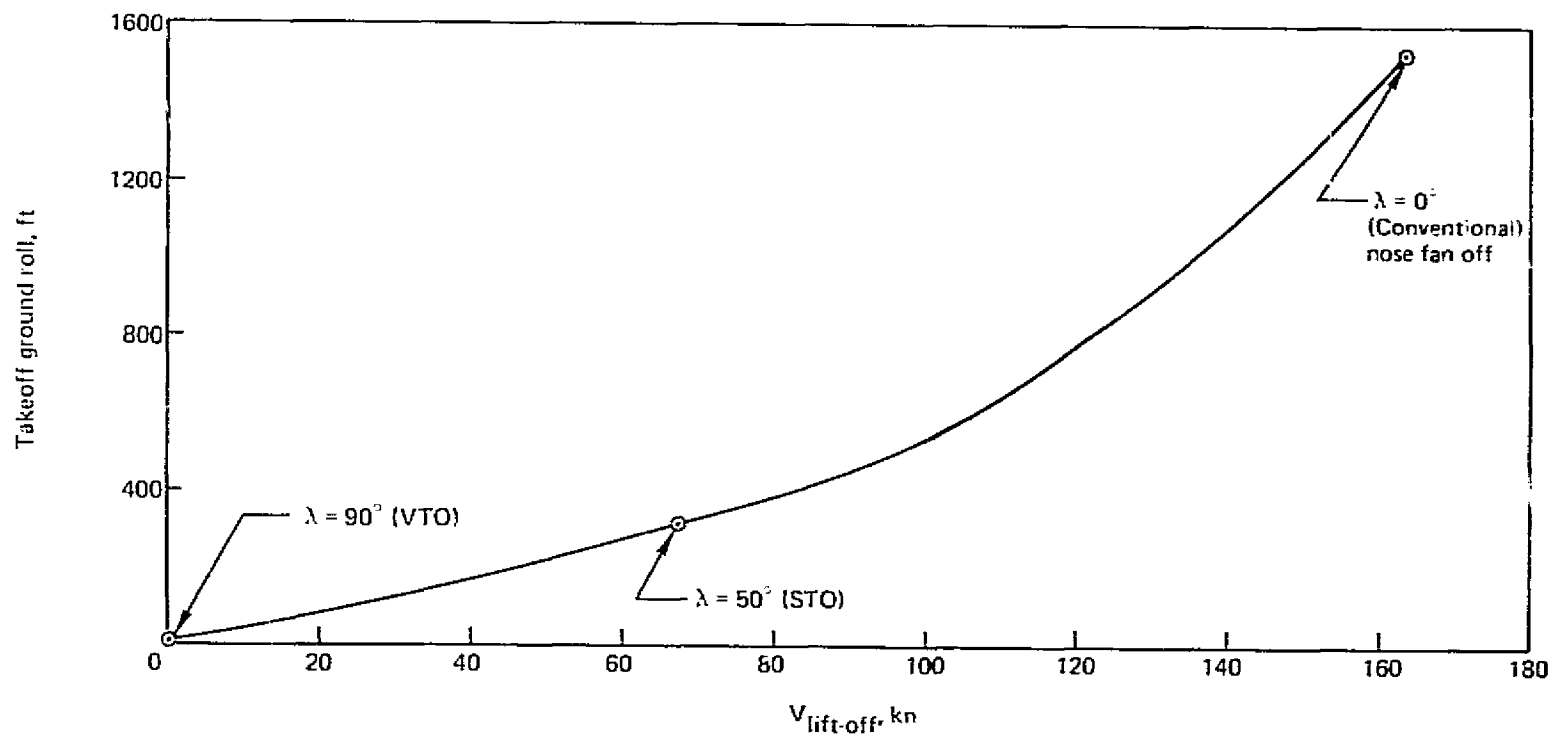

Figure 4.1.7-3.—Takeoff Performance LCFA 1041-134, All New Airplane

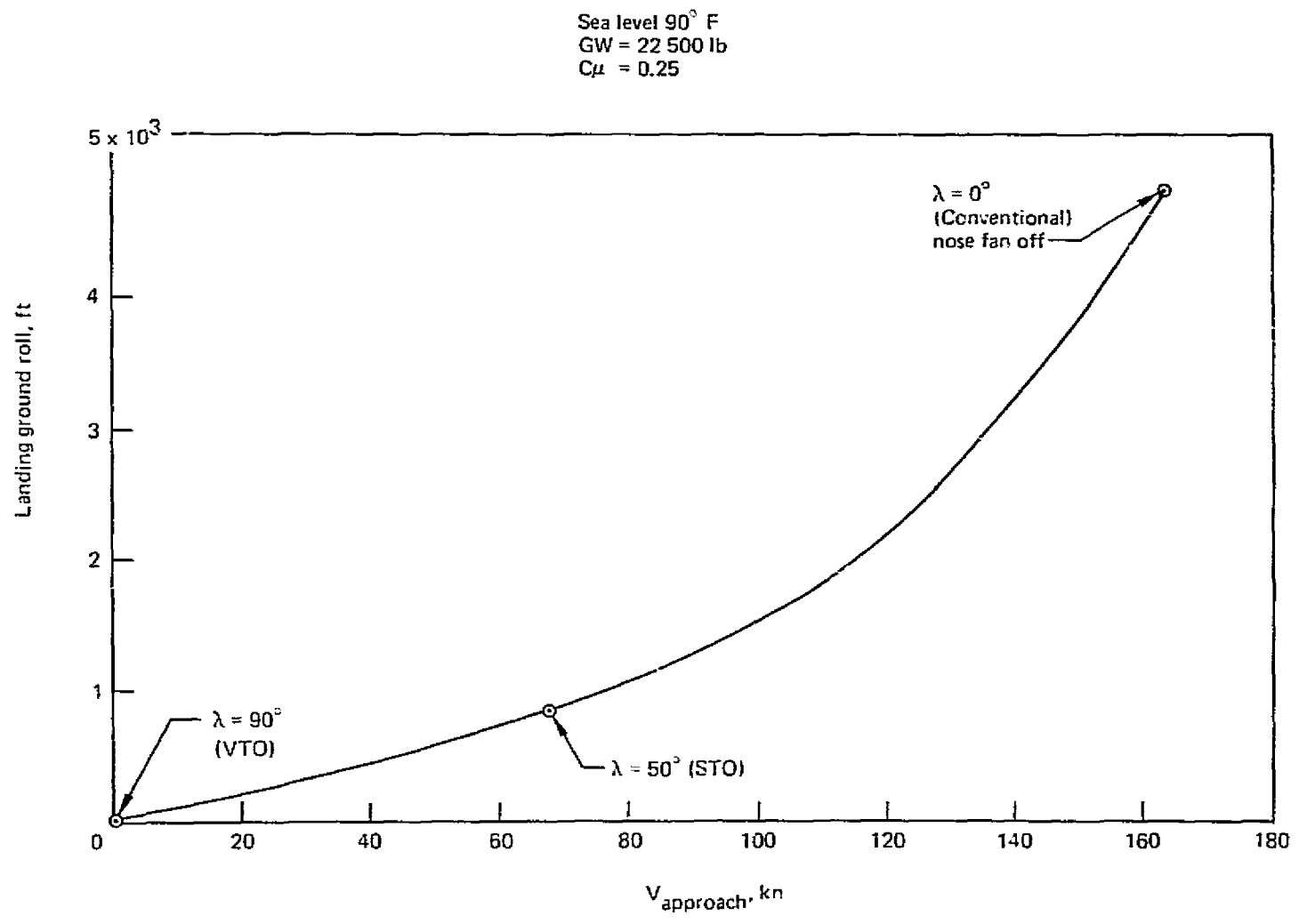

Figure 4.1.7-4.—Landing Performance LCFA 1041-134 All New Airplane

The level flight performance envelope is presented in Figure 4.1.7-5 for the cruise and V/STOL configurations. The cruise configuration altitude capability is about 37,000 ft. and the maximum Mach number is about .76. The V/STOL configuration envelope is based on an optimum value of engine tilt angle,  $\lambda$ , at each point on the envelope. Hovering is possible at altitudes up to 10,000 ft. and the maximum flaps down altitude is about 29,000 ft. No credit has been taken for induced aerodynamic lift in these calculations. The crosshatched area represents conditions where the envelopes overlap, allowing the conversion maneuver to be performed.

#### 4.2 MODIFIED AIRCRAFT (Full flight envelope)

Several candidate aircraft were reviewed for potential use as a modification base for the lift/cruise fan technology airplane and the T-39 (Sabreliner) was selected because it is available from government inventory, it is a low wing configuration and its size is correct for the available propulsion system. The modified airplane differs from the all new aircraft in two important ways; the wing loading is considerably lighter and it is about 700 pounds heavier.

A list of the candidate aircraft with their general characteristics are given in Table 4.2-1.

##### 4.2.1 Configuration

Figure 4.2-1 shows the general arrangement of the modified Sabreliner (1041-135-2). An overlay comparison with the operational airplane is shown in Figure 4.2-2.

The lift and drag characteristics are given in Figure 4.2.3, 4.2.4 and 4.2-5. The necessary modifications include: a new nose to accommodate the fan installation; new vertical and horizontal tails; canopy replaced with lightweight enclosure that is fixed in place; mechanical flight control system adapted; (Use of control actuation and retention of the existing mechanical system will be investigated); flap deflection will be increased to clear the tilting pod; new hydraulic system due to increased



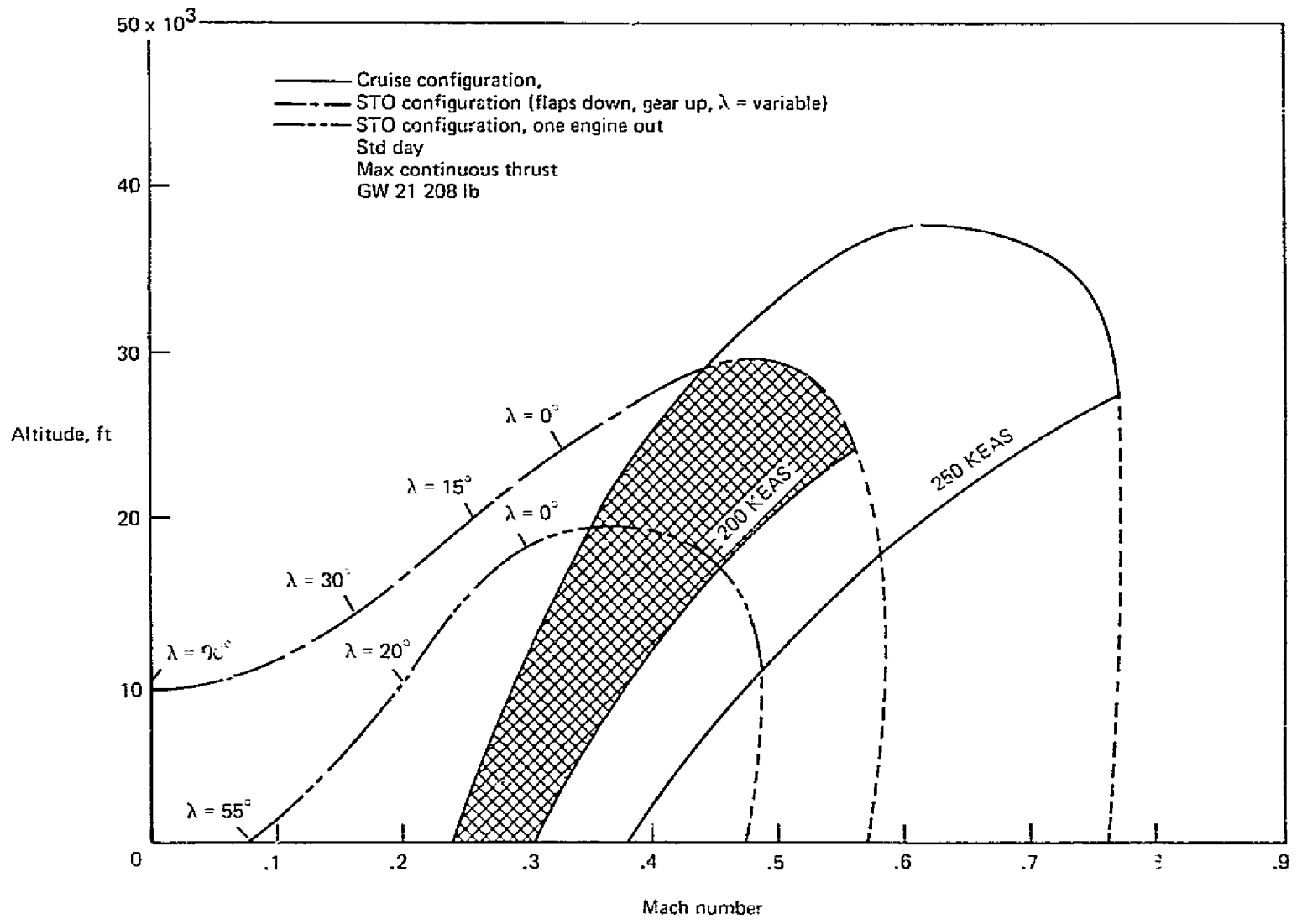

Figure 4.1.7-5.—Level Flight Capability LCFA 1041-134 All New Airplane

Table 4.2-1.—Possible Technology Demonstrator Modification Comparison Chart

	<u>GROSS WT.</u> <u>LBS.</u>	<u>EMPTY WT.</u> <u>LBS.</u>	<u>WING AREA</u>	<u>M<sub>MAX</sub></u>	<u>REMARKS</u>
T-39 SABRELINER	18650	9260	342	.80	
LEARJET	17000	8300	231	.83	SMALL
CESSNA CITATION	11650	6350	260	.60	SMALL
LOCKHEED JETSTAR	44000	24280	543	.82	LARGE
IAI WESTWIND	20500	22600	308	.77	WING HIGH ON BODY
GULFSTREAM II	62000	35600	794	.85	LARGE
DASSAULT FALCON 10	18300	10400	260	.80	FOREIGN
HS 125	23300	11900	353	.755	FOREIGN

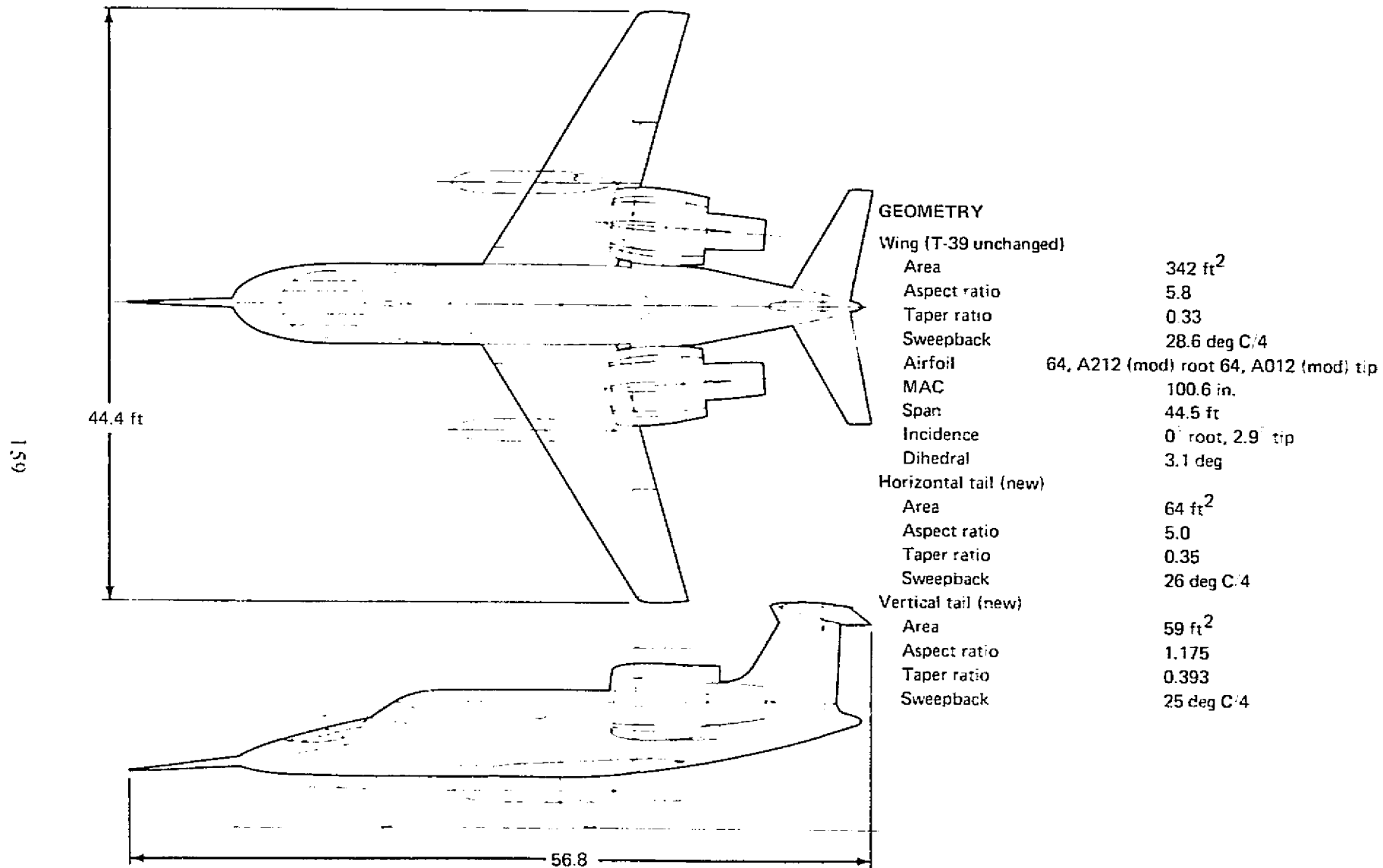

Figure 4.2-1.—Technology Airplane Modified T-39 (Sabreliner), Model 1041-135-2

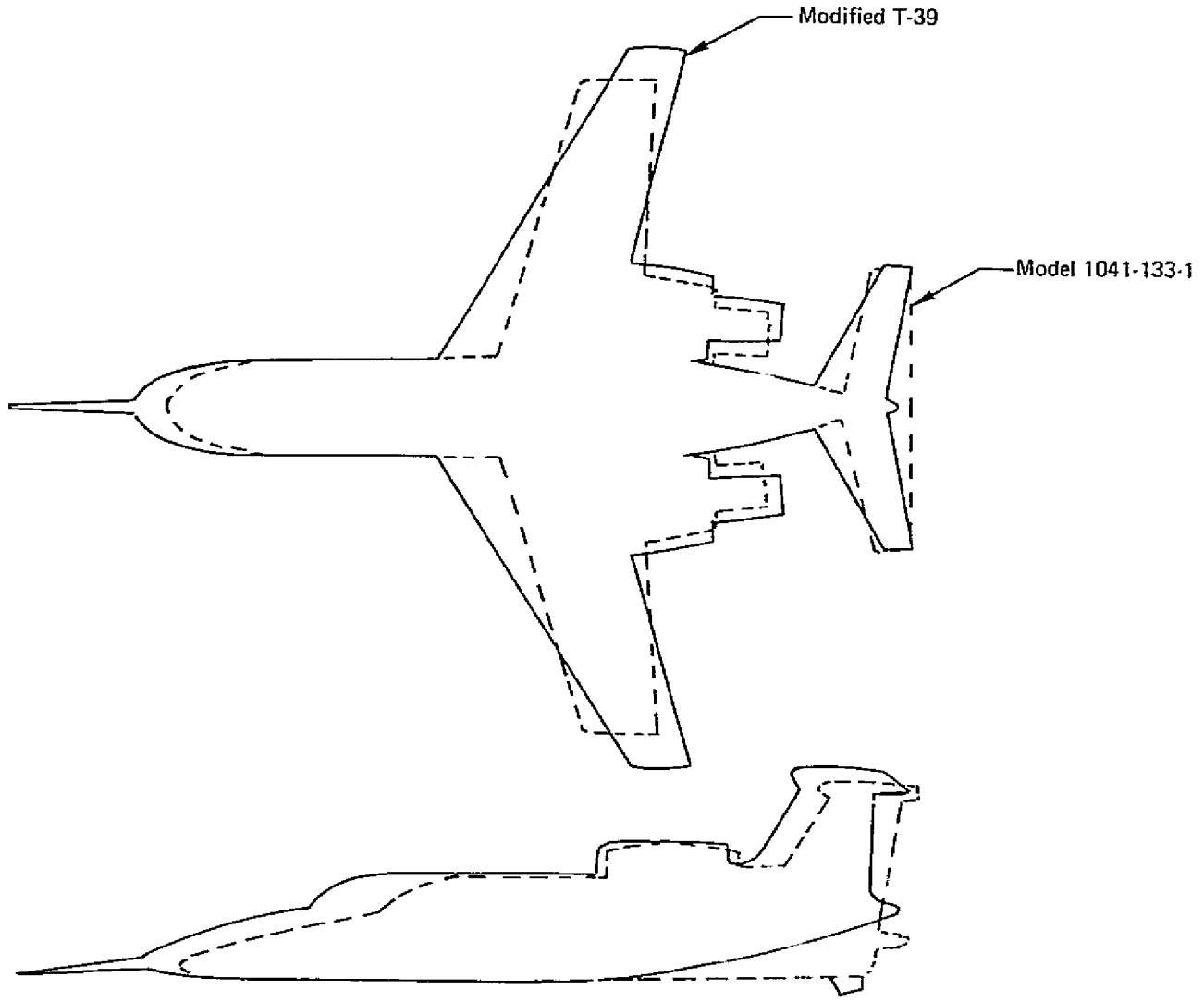

Figure 4.2-2.-Overlay Comparison

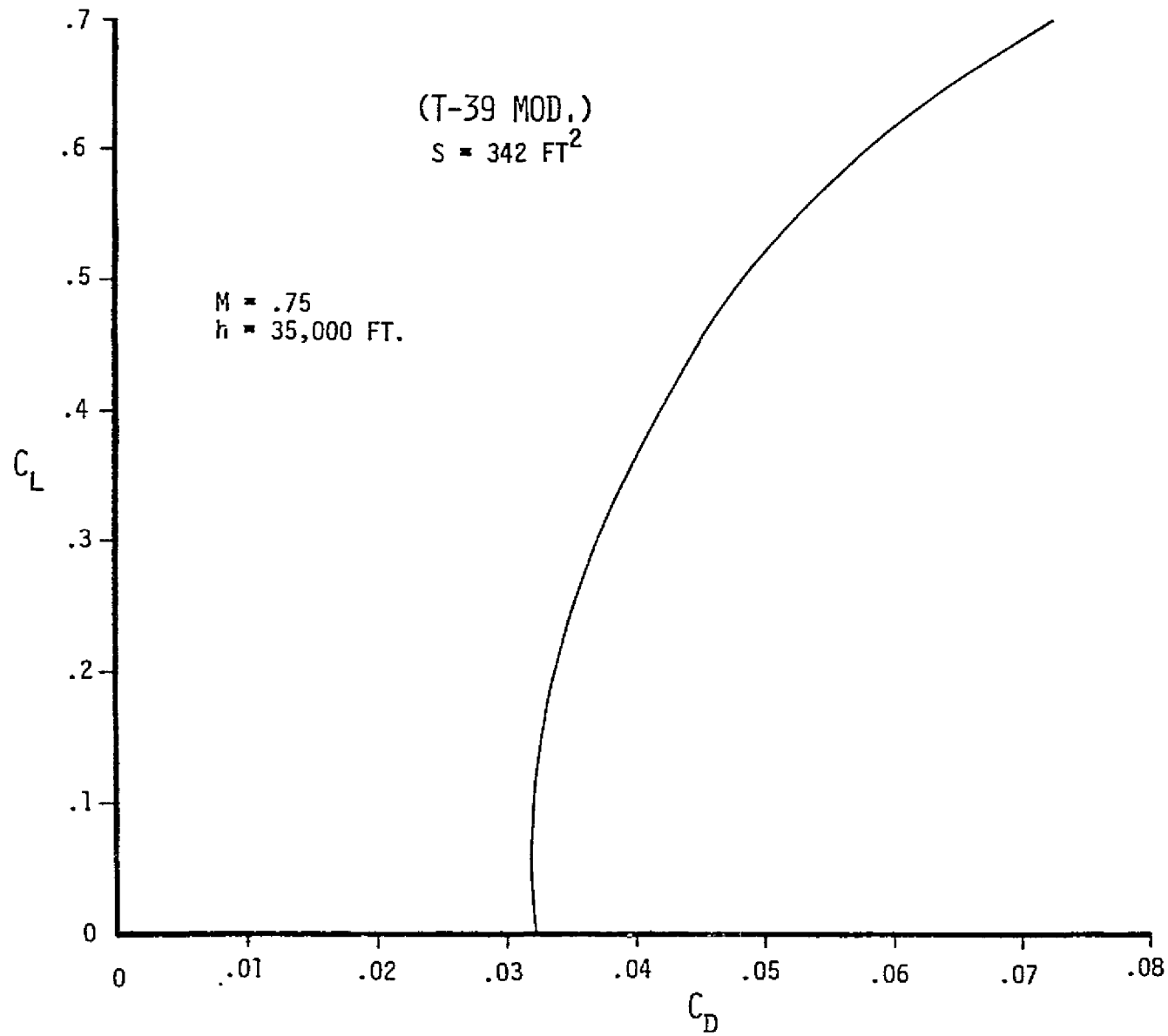

Figure 4.2-3.—Drag Polar LCFA 1041-135-2

162

$C_L$

LCFA 1041-135-2 (T-39 MOD.)  
LCFA 1041-136 (T-39 LO SPEED)  
 $S = 342 \text{ FT}^2$

FLAPS DOWN  
GEAR DOWN  
NACELLE TILT ANGLE =  $45^\circ$   
POWER OFF

1.4  
1.2  
1.0  
.8  
.6  
.4  
.2  
0

0 0.1 0.2 0.3 0.4  
 $C_D$

Figure 4.2-4.-Low-Speed Drag Polar

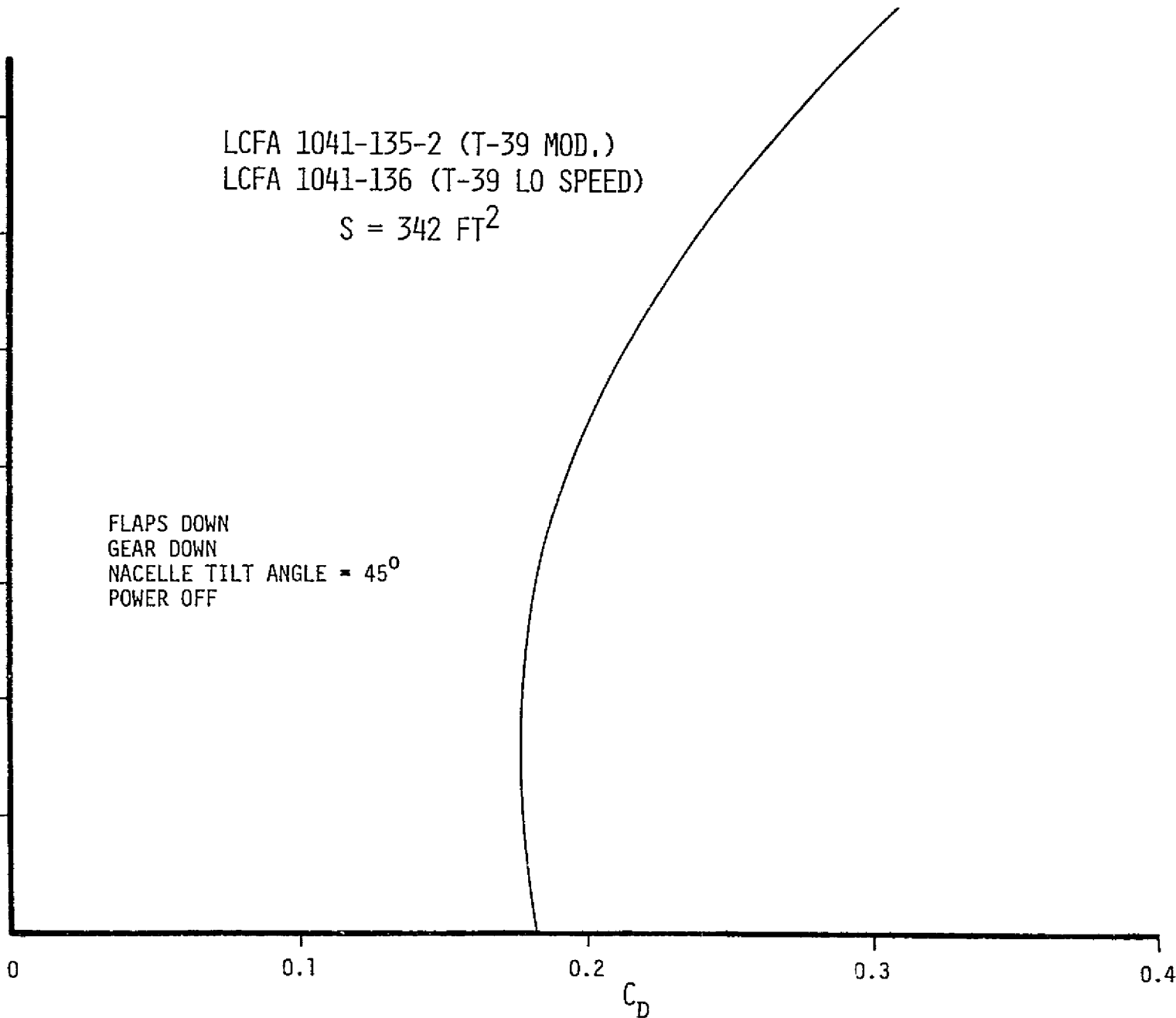

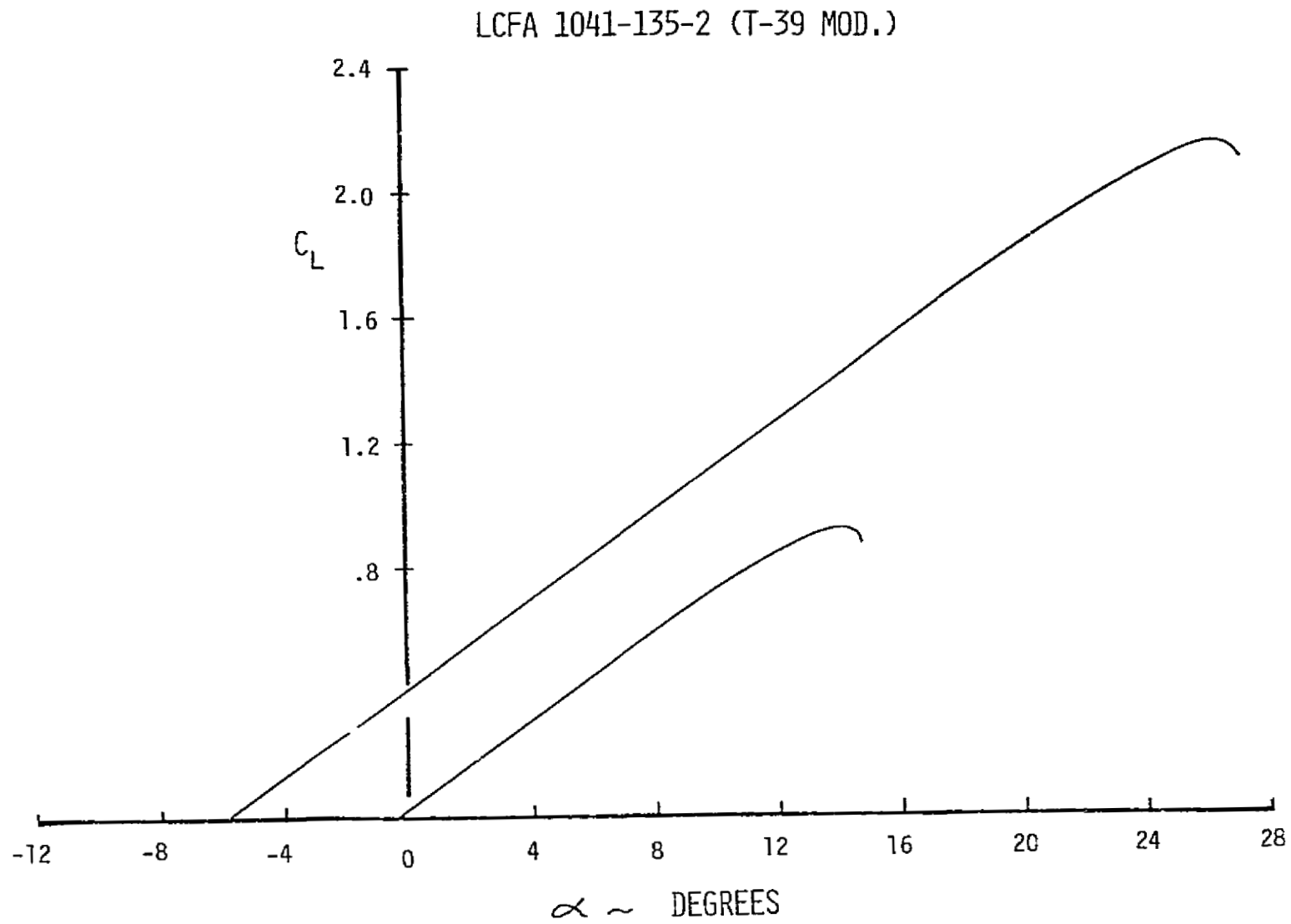

Figure 4-2-5.-Aerodynamic Lift Power Off

power requirements; reworked landing gear metering needed to accommodate the higher sink speed requirements of vertical landing; new nose gear installation needed to accommodate an aft swinging strut due to fan installation; body strengthening required for the lift/cruise propulsion pod installation and the new "T" tail loads. The propulsion system will be the same as one in the all new technology airplane.

#### 4.2.2 Flight Controls

The modified T-39 (Model 1041-135-2) requires the same flight control systems as the all new airplane. The hover inertia and gross weight characteristics are within the capability of the reaction control system for airplane trim and control during VTOL.

#### 4.2.3 Weight & Balance

The modification of the T39A to a V/STOL technology airplane resulted in a net empty weight increase of 7240 lbs. The resulting technology airplane is 700 lbs. heavier than the all new airplane. The operating weight is 17,100 lbs.

#### 4.2.4 Performance

The takeoff and landing performance is improved over the all new airplane due to the difference in wing loading: from 120 lb/ft<sup>2</sup> to 70 lb/ft<sup>2</sup>. This increased capability is unimportant.

The number of VTO circuits available from the emergency landing weight is reduced due to the weight increase. Three instead of five are available.



#### 4.3 MODIFIED AIRCRAFT (LIMITED FLIGHT ENVELOPE)

This version of the modified Sabreliner airplane was examined to determine if significant cost savings were possible. The savings are nominal since much of the program cost is associated with the propulsion system which is essentially identical to that of the full envelope airplane. Flight is limited to takeoff and landing traffic speeds, about 160 KEAS.

Major development savings consist of: a reduced flight test program; analysis and simulation of high Mach number characteristics is not required; drag refinements are not necessary in analysis and fabrication; high speed tunnel testing is not required; ejection through canopy verification is not required.

Figure 4.3-1 shows the general arrangement of Model 1041-136, the limited flight envelope modified existing airplane. The modifications are the same as for the previously described airplane except:

An open cockpit is used; Landing gear is fixed; fan nozzles are fixed on the aft pods, and no nose fan inlet doors are used.

The weight savings resulting from these changes make this version of modified airplane about 100 lbs. heavier than the all new airplane. It will have about the same VTO mission capability as the all new airplane.

The propulsion system will be the same as that for the all new technology, except that the inlet vanes for the nose fan will be fixed.

This airplane will have the same flight controls system and empennage features as the unlimited modified airplane (1041-135-2).

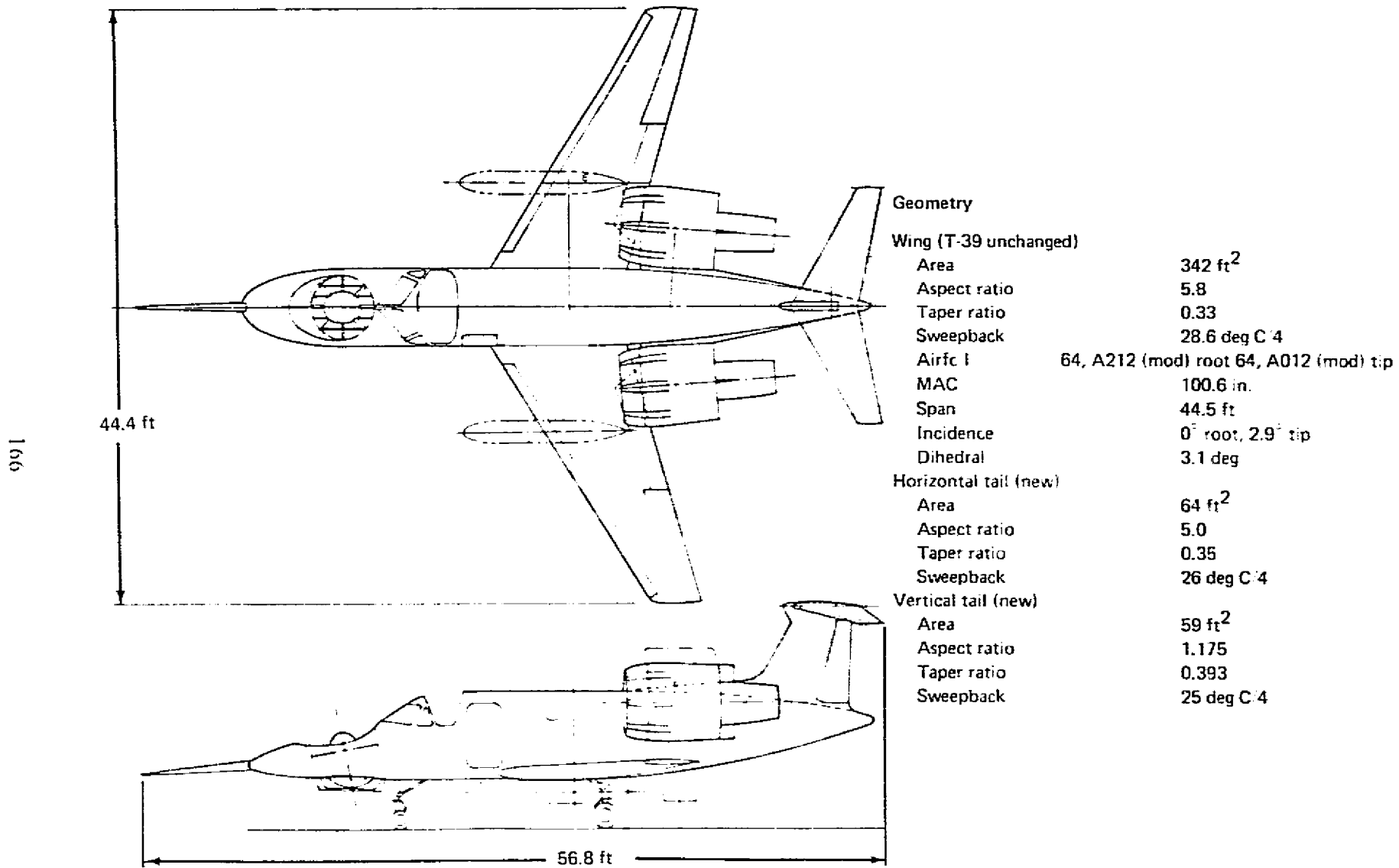

Figure 4.3-1.—Limited Flight Envelope Technology Airplane  
Modified T-39 (Sabreliner), Model 1041-136

#### 4.4 TECHNOLOGY AIRCRAFT COMPARISON

The comparison of the three technology airplanes offers classic cost/weight/performance tradeoffs. Table 4.4-1 presents a weight comparison of the three airplanes. The modified Sabreliner with normal flight envelope is approximately 700 lbs. heavier than the new airplane. The Sabreliner with limited flight envelope is 100 lbs. heavier.

In summary:

The all new -134 costs the most, has low risk on weight and has good performance.

The modified T-39 is less expensive, has less weight margins and has good performance.

The low speed modified T-39 is the least expensive; it has low risk on weight, but its performance capability is limited to low speed.

*Table 4.4-1.-Weight Summary Technology Airplane*

Configuration	New airplane	Modified Sabreliner	Low-speed Sabreliner
Model 1041	-134	-135 2	-136
Structure, lb	5 650	6 320	6 020
Propulsion, lb	7 550	7 580	7 530
Equipment, lb	2 600	2 600	2 350
Weight empty, lb	15 800	16 500	15 900
Nonexpendable useful load, lb	600	600	600
Operating weight, lb	16 400	17 100	16 500

APPENDIX A

EXCERPTS FROM WORK STATEMENT & DESIGN GUIDELINES

## STATEMENT OF WORK

### DESIGN DEFINITION STUDY OF A LIFT CRUISE FAN TECHNOLOGY V/STOL AIRCRAFT

#### INTRODUCTION

1.0 Recent studies by the Navy, and by NASA during contractor studies have confirmed the future need for a high performance V/STOL aircraft for both military and civil applications. The Navy requires a multi-mission V/STOL aircraft in the 1980's which is capable of sea control operations from many platforms as well as ship-to-shore and shore-to-ship functions.

1.1 The turbotip or mechanically driven lift/cruise fan V/STOL aircraft exhibits an excellent potential because of its high speed, high altitude and range capability coupled with its overall operational suitability. The expected benefits of this concept for multirole applications makes it advisable to conduct a lift/cruise fan technology aircraft flight program. Successful completion of the flight program and related technology support programs in propulsion, aerodynamics, and simulation will result in a firm base from which multi-mission aircraft for the U. S. Navy can be designed with confidence. The technology developed would also be useful in consideration of future civil utility aircraft for purposes such as off-shore oil rig operations and other construction, lumbering or development sites that are located in areas difficult to reach rapidly by other modes of transportation.

1.2 As an initial step in developing a realistic technology aircraft, a study phase shall be performed to quantify Navy operational aircraft requirements, develop conceptual designs of research aircraft and assess their applicability to operational requirements. This design definition study shall be directed toward a minimum cost research program consistent with providing maximum research productivity, Navy operational demonstration capabilities and proper attention to safety.

2.0. Basic design guidelines for the technology aircraft are given in Attachment I. This technology aircraft will be used to exploit the benefits of the lift/cruise fan system, to define future V/STOL aircraft design requirements, to obtain operational experience to develop operating techniques to serve as a facility for control/propulsion system tests, and for experiments related to V/STOL terminal area operation with advanced stabilization, guidance and navigation systems. . . .

### 2.1.1 Part I - NAVY OPERATIONAL AIRCRAFT REQUIREMENTS

The contractor shall evaluate Navy requirements for V/STOL aircraft to perform the missions outlined in Attachment II. . . . Considering mission deficiencies, cost and the potential for design commonality, the Contractor shall postulate a compromise design mission and design approach to commonality for approval of Navy and NASA. Based upon this compromise mission, a multipurpose aircraft (or aircraft system) shall be synthesized and evaluated for adequacy against the original design missions.

### 2.1.2 Part II - DESIGN DEFINITION OF LIFT/CRUISE FAN TECHNOLOGY AIRCRAFT

To allow a true comparison of program cost and value, the Contractor shall prepare and evaluate at least three separate design approaches for the technology aircraft. One approach will be based upon a new airframe using the compromise aircraft design of Part I, the second will be based upon modifying an existing airframe to accept the propulsion system and demonstrate an ability to operate in a full envelope (i.e., hover, transition, and hi-speed cruise) and the third approach would be based upon modifying an existing airframe to accept the propulsion system but be flight limited to a maximum velocity of approximately 160 knots. . . .

2.1.2.1 The Contractor shall provide for each design approach a summary of the total data base such as airframe, engines, components, aerodynamic, control, noise, availability of off-the-shelf hardware, and others. Those technical development programs and their scheduling which are required to support the technology demonstrator aircraft will be delineated for each design approach. Total program budgetary costs shall be defined for

each design approach by fiscal year expenditures and key milestones will be established. The Contractor shall determine propulsion system costs, through discussions with the appropriate manufacturers and the Government, and include the cost of design, preliminary flight tests (PFRT), hardware procurement, ground support and spares in the budgetary cost estimates. Cost and programs schedule for budgetary purposes shall be based upon the following:

- 1) A one aircraft program for each of the three design approaches listed above.
- 2) For a second aircraft in each of the above one aircraft programs.



DESIGN GUIDELINES AND CRITERIA  
FOR  
DESIGN DEFINITION STUDY OF A LIFT CRUISE FAN TECHNOLOGY V/STOL AIRCRAFT

The purpose of these guidelines is to provide a basis for comparing the conceptual designs of V/STOL Technology aircraft using the remote lift-cruise fan propulsion system. These guidelines will provide direction for only those items required for conceptual design considerations. This is not an attempt to provide criteria for either the preliminary or detail design of military aircraft.

Except where specific criteria are given, handling qualities shall be consistent with the intent of AGARD-R-577-70 and MIL-F-83300. Under MIL-F-83300, the aircraft will be considered in the Class II category. Two levels of operation will be considered. Level I is normal operation with no failures. Level 2 is operation with a single reasonable failure of the propulsion or control system.

Upon any reasonable failure of a power plant or control system component, the aircraft shall be capable of completing a STOL flight mode takeoff and continuing sustained flight. For the vertical landing flight mode, upon failure, sustained hovering flight is required at some useful aircraft gross weight to be determined by the contractor. At higher gross weights for which hovering flight cannot be sustained after a failure, sinking vertical flight is permitted provided that aircraft attitude remains controllable and the landing gear design sink is not exceeded. Fan failure during low speed flight is not a design requirement (as similarly the case for rotor type or propeller-driven concepts), although consideration of gas generator failure is a design requirement.

#### 1.0 Flight Safety and Operating Criteria

##### 1.1 Handling Qualities Criteria (low speed powered lift mode)

Definitions of the two levels are as follows:

Level 1: Flying qualities are as near optimal as possible and the aircraft can be flown by the average military pilot.

Level 2: Flying qualities are adequate to continue flight and land. The pilot work load is increased but is still within the capabilities of the average military pilot.

Level 2: Flying qualities are adequate to continue flight and land. The pilot workload is increased but is still within the capabilities of the average military pilot.

1.1.1 Altitude Control Power (S.L., 90°F)

Applicable for all aircraft weights and at any speed up to  $V_{con}$ . For purposes of this study, the VTOL values will apply near hover (0 to 40 kts); where the STOL values will apply when operating above 40 knots. The Tables list minimum values, higher levels are desirable for research purposes.

Level 1: The low speed control power shall be sufficient to satisfy the most critical of the three following sets of conditions:

Conditions (a) --- to be satisfied simultaneously,

- (1) Trim with the most critical CG position.
- (2) In each control channel provide control power, for maneuver only, equal to the most critical of the requirements given in the following table.

Axis	<u>Maximum Control Moment</u> Inertia		Attitude Angle in 1 sec after a Step Input	
	VTOL	STOL	VTOL	STOL
Roll	$\pm 0.9 \text{ rad/sec}^2$	$\pm .6 \text{ rad/sec}^2$	$\pm 15 \text{ deg}$	$\pm 10 \text{ deg}$
Pitch	$\pm 0.5 \text{ rad/sec}^2$	$\pm .4 \text{ rad/sec}^2$	$\pm 8 \text{ deg}$	$\pm 6 \text{ deg}$
Yaw	$\pm 0.3 \text{ rad/sec}^2$	$\pm 0.2 \text{ rad/sec}^2$	$\pm 5 \text{ deg}$	$\pm 3 \text{ deg}$

These maneuver control powers are applied so that 100% of the most critical and 30% of each of the remaining two need occur simultaneously.

Condition (b) -- At least 50% of the above control power shall be available for maneuvering, after the aircraft is trimmed in a 25 knot crosswind.

Condition (c) -- At least 90% of the control power specified in condition(a) shall be available after compensation of the gyroscopic moments due to the maneuvers specified in condition (a). This condition includes trim with the most critical CG position.

Level 2: The low speed control power shall be sufficient to satisfy, simultaneously, the following:

- (1) With the most critical CG position trim after any reasonable single failure of power plant or control system.
- (2) In each control channel, provide control power, for maneuver only, equal to at least the following:

Axis	Control Moment Inertia		Attitude Angle in 1 sec after a Step Input	
	VTOL	STOL	VTOL	STOL
Roll	$\pm 0.4 \text{ rad/sec}^2$	$\pm 0.3 \text{ rad/sec}^2$	$\pm 7 \text{ deg}$	$\pm 5 \text{ deg}$
Pitch	$\pm 0.3 \text{ rad/sec}^2$	$\pm 0.3 \text{ rad/sec}^2$	$\pm 5 \text{ deg}$	$\pm 5 \text{ deg}$
Yaw	$\pm 0.2 \text{ rad/sec}^2$	$\pm 0.15 \text{ rad/sec}^2$	$\pm 3 \text{ deg}$	$\pm 2 \text{ deg}$

Simultaneous maneuver control power need not be greater than 100% - 30% - 30%.

### 1.1.2 Flight Path Control Power (SL to 1000 ft., 90°F).

#### 1.1.2.1 VTOL (0-40 kt TAS and zero rate of descent)

At applicable aircraft weights and at the conditions for 50% of the maximum attitude control power of critical axis specified in para. 1.1.1 it shall be possible to produce the following incremental accelerations for height control:

Level 1:

- (a) In free air  $\pm 0.1g$
- (b) With wheels just clear of the ground  
-0.10g, + 0.05g

Level 2:

- (a) In free air - 0.1g, + 0.05g
- (b) With wheels just clear of the ground  
- 0.10g, + 0.00g

It shall also be possible to produce the following horizontal incremental acceleration, but not simultaneously with height control.

Level 1:  $\pm 0.15g$

Level 2:  $\pm 0.10g$

At applicable aircraft weights it shall be possible to produce the following stabilized thrust-weight ratios without attitude control inputs.

Level 1:  $\frac{F}{W} = 1.05$  in free air (Takeoff power rating)

Level 2:  $\frac{F}{W} = 1.03$  in free air (Emergency power rating)

#### 1.1.2.2 VTOL and STOL Approach (40 kts. to $V_{CON}$ )

At the applicable landing weight the aircraft shall be capable of making an approach at 1000 FPM rate of descent while simultaneously decelerating at 0.08g along the flight path.

It shall be possible to produce the following incremental normal accelerations by rotation alone (angle of attack change and constant thrust) in less than 1.5 seconds at the STOL landing approach airspeed where reasonable rotation (angle of attack changes) will produce at least 0.15g's.

Level 1:  $\pm 0.1g$

Level 2:  $\pm 0.05g$

It shall be possible to produce the following normal accelerations in at least 0.5 seconds for flight path, flare, or touchdown control by either thrust changes or combined thrust changes and rotation at STOL landing approach speeds below which 0.15g's can be produced by reasonable rotation alone.

Level 1:  $\pm 0.1g$

Level 2:  $\pm 0.05g$

### 1.1.3 VTOL and STOL Low Speed Control System Lags (S.L. to 1000 ft. $90^0$ ).

The effective time constant (time to 63% of the final value) for attitude control moments and for flight path control forces shall not exceed the levels given in the following table:

	Level 1	Level 2
Attitude Control Moments	0.2 sec	0.3 sec
Flight Path Control Forces	0.3 sec	0.5 sec

With a step-type input at the pilot's control the commanded control moment or force shall be applied within the following:

Level 1: 0.3 seconds for 0.5 inches of pilot's control

0.5 seconds for full pilot's control

Level 2: 0.5 seconds for full pilot's control

### 1.2 STOL Takeoff Performance

The climbout gradient in the takeoff configuration, at takeoff gross weight, with gear down and most critical power plant failed at lift off shall be positive and the aircraft will continue to accelerate.

During takeoff wing lift shall not exceed  $0.8 C_{L_{MAX}}$ . No catapults or arresting gear will be utilized. The rolling coefficient of friction will be 0.03 (for calculations).

### 1.3 Conversion Requirements (STOL and VTOL)

It must be possible to stop and reverse the conversion procedure quickly and safely without undue complicated operation of the powered lift controls.

The maximum speed in the powered-lift configuration shall be at least 20% greater than the power-off stall speed in the converted configuration for level 1 operation and the speed in the powered lift configuration shall be at least 10% greater than the power off stall speed for the level 2 operation.

## 2.0 Mission

### 2.1 Mission Summary

The mission, payload, and range of the technology aircraft will be derived through consultation with the contractor, Navy and NASA and will be based upon the findings of Part I of this study.

### 3.0 General Design Guidelines

3.1 Austerity is to be stressed but not by compromising safety.

3.2 The limit load factor will be no less than + 2.5g, - 0.5g.

3.3 Sufficient attitude control power will be available to perform research on control requirements. The contractor shall indicate those axes where greater control power than required in section 1.0 would be made available for research purposes.

3.4 The modified existing airframe designed with the limited flight envelope should have a maximum flight speed of approximately 160 knots. This aircraft could use a fixed landing gear. A retracting gear would be acceptable if it were available at no cost increase.

3.5 New aircraft components will be designed for approximately 500 flight hours.

3.6 Additional Information

- Minimum Mission Time
  - VTOL Missions 1/2 hour
  - STOL Missions 1 hour
  - Cruise/Endurance Mission 2 hour
- Pay Load (not including crew) 2500 lbs. (minimum)  
Volume 50 cu. ft.
- Crew 2 pilots (flyable by one pilot only, or by either pilot)
- Sink rate at touchdown 12 fps at max landing weight
- Ceiling (Low Speed restrictive configuration) 15,000 ft.  
(Nonpressurized cockpit)
- Cockpit Environmental System Minimum
- Pilot's Primary Flight Controls Stick and Pedals
- Ejection System for both pilots
- Maximum possible visibility

Summary of Missions, Design Guidelines, and Design Technical Information Desired for the Preliminary Aircraft Designs and Multipurpose Aircraft Designed for the Compromise Mission (Part I)

INTRODUCTION

The purpose of Attachment II is to provide the basis for designing the preliminary aircraft of Part I and the multipurpose aircraft designed for the compromise mission as specified in Part I of the Statement of Work. Five missions are described.

Mission Summary and Design Requirements

1.0 MISSION SUMMARY

A. Surface Attack (SA) - Sea Control Mission

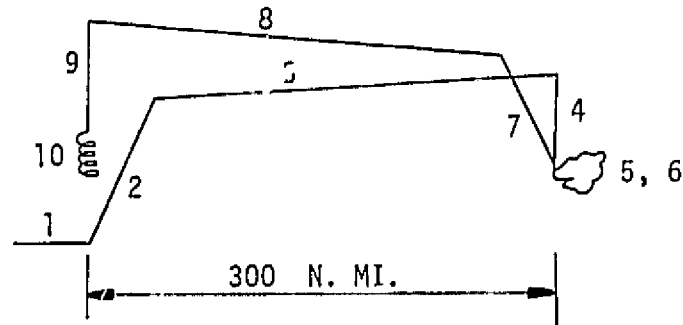

Loading: (2) Harpoon, (2) AIM-9

Conditions: STO with 400 ft deck run and vertical landing both at 89.8°F. Ten knots WOD for takeoff. All fuel consumption to be calculated at Standard Day Conditions.

Note: External fuel permitted if within STO capability; tanks dropped when empty or prior to combat whichever occurs first.

1. Warm-up, takeoff, accel. to climb speed - 2-1/2 min. at intermediate thrust. Installed sea level static conditions.
2. Climb - To BCAV at intermediate thrust.
3. Cruise - To radius to BCAV
4. Descend to 20,000 ft. No fuel used, no time or distance credit.
5. Loiter - 2 hours at 20,000 ft. at speed for best endurance.



6. Combat - 5 min. at intermediate thrust at 20,000 ft. MN = 0.3.
7. Climb - From 20,000 ft. to BCAV at intermediate thrust
8. Cruise - At BCAV to point of takeoff
9. Descend to Sea Level - No fuel used, no time or distance credit
10. Landing Allowance and Reserve - fuel for:
  - (a) 10 min. loiter at best endurance speed at sea level
  - (b) 5% total initial fuel

B. Antisubmarine (ASW)

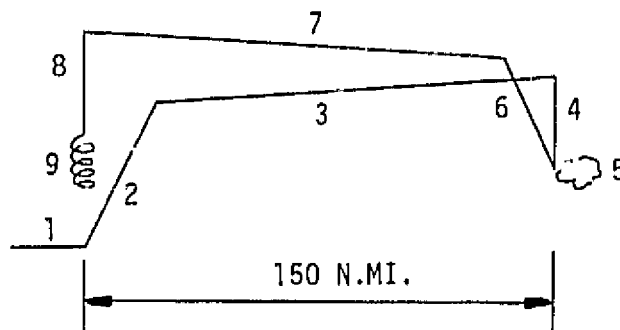

Loading: (2) MK - 46 torpedoes, (50) mixed sonobuoys -  
 (sonobuoys wt. 1760 lb) without containers

Conditions: STO with 400 ft. deck run and vertical landing, bot..  
 at 39.8<sup>0</sup>F. Ten knots WOD for takeoff. All fuel  
 consumption to be calculated at Standard Day Conditions.

1. Warm-up, takeoff, accel. to climb speed - 2-1/2 intermediate thrust. Installed sea level static conditions.
2. Climb - To BCAV at intermediate thrust
3. Cruise - To radius at BCAV
4. Descend - To 10,000 ft. no fuel used, no time or distance credit.
5. Loiter - At 10,000 ft. and speed for best endurance - 4 hrs.
6. Climb - At intermediate thrust to BCAV.

7. Cruise - To starting point at BCAV
8. Descend - To sea level. No fuel used, no time or distance credit.
9. Landing Allowance and Reserve - Fuel for:
  - (a) 10 min. at best endurance speed at sea level
  - (b) 5% total initial fuel

C. Vertical Onboard Delivery (VOD)

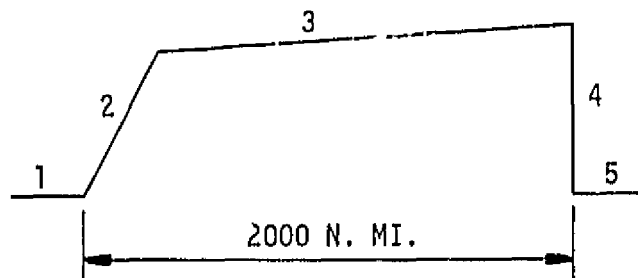

Loading: 5000 lb. disposable payload, may include pallets, but not life rafts, cargo loading equipment, etc.

Conditions: STO with 450 ft. deck run and vertical landing, both at 89.8°F. Twenty knots WOD for takeoff. All fuel consumption to be calculated at Standard Day conditions.

1. Warm-up, takeoff, accel. to climb speed - 2-1/2 min. at intermediate thrust. Installed sea level static conditions.
2. Climb - To BCAV at intermediate thrust.
3. Cruise - To radius at BCAV.
4. Descend - To sea level. No fuel used, no time or distance credit.
5. Landing Allowance and Reserve - Fuel for:
  - (a) 20 min. Loiter at best endurance speed at sea level.
  - (b) 5% total initial fuel

Note: VOD designs should be sized to carry at least the following:

- (a) Passengers: 17 - 23 plus 3 crew
- (b) 350 in rotor blade
- (c) F401 engine on stand (no afterburner)
- (d) 463L Half pallet (88" x 54")
- (e) TF34 engines on stand

If internal carriage of the rotor blade creates an adverse impact upon the aircraft design external carriage may be considered. External carriage of blades up to 420 inches long should be examined.

D. Surveillance

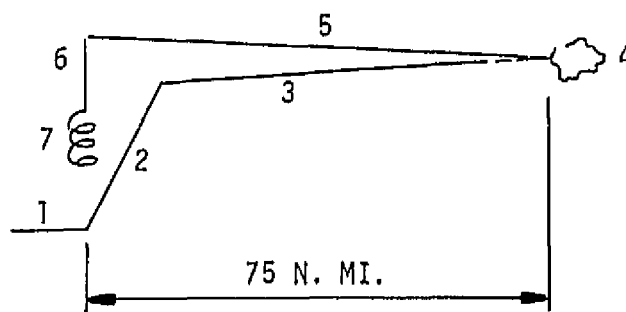

Conditions: STO with 400 ft. deck run and vertical landing both at 89.8°F. Ten knots WOD for takeoff. All fuel consumption to be calculated at Standard Day Conditions.

Loading      Mission Avionics

1. Warm-up, takeoff, and accel. to climb speed - 2-1/2 min. at intermediate thrust. Installed sea level static conditions.
2. Climb - To BCAF at intermediate thrust
3. Cruise - To radius at BCAF
4. Loiter - On station 4 hours at best endurance speed at 25,000 ft. or higher.
5. Cruise - To point of takeoff at BCAF.
6. Descend - To sea level. No fuel used, no time or distance credit.

7. Landing allowance and reserve - Fuel for:

- (a) 10 min. loiter at best endurance speed at sea level
- (b) 5% total initial fuel

E. Combat (Strike) Search and Rescue (CSAR)

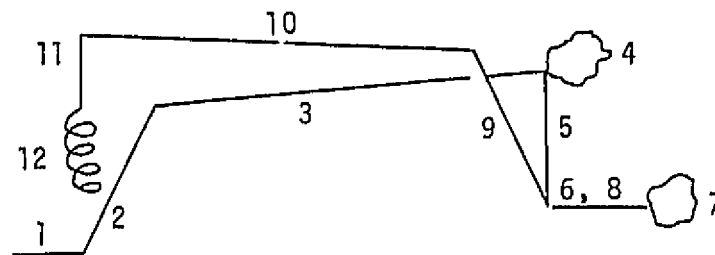

Loading: (2) AIM-9, MINI GUN and 1000 Rounds AMMO  
(Production Gun Turret System) (all retained)  
and 600# Armour.

Conditions: STO with 400 ft. deck run, mid-point hover, and  
vertical landing at 89.8<sup>0</sup>F. All fuel consumption  
to be calculated at Standard Day conditions.

Note: External fuel permitted if within STO capability,  
tanks dropped when empty or prior to hover whichever  
occurs first.

1. Warm-up, takeoff, accel. to climb speed - 2-1/2 min. at intermediate thrust. Installed sea level static conditions.
2. Climb - To BCAV at intermediate thrust
3. Cruise - To 350 nm at BCAV less distance covered in climb
4. Loiter - 20 min. at optimum altitude and airspeed
5. Descent - To sea level, no fuel used, no time or distance credit.
6. Dash - 50 nm at sea level, Mach 0.8 to pickup area

7. Personnel Pickup - Fuel allowance for 10 min. hover at sea level (OGE) pickup 2 personnel (400 lb.)
8. Dash - At Mach No. 0.8, 50 nm at sea level
9. Climb - To BCAV at intermediate thrust
10. Cruise - At BCAV to point of takeoff, 350 nm less distance covered in climb,
11. Descend - To sea level. No fuel used, no time or distance credit.
12. Landing Allowance and Reserve - Fuel for:
  - (a) 10 min. loiter at best endurance speed at sea level
  - (b) 5% total initial fuel.

#### MISSION NOTES

1. If a short term engine rating is developed which provides greater than intermediate thrust for takeoff the takeoff fuel allowance shall be calculated as the sum of:
  - (a) 2 minutes at intermediate thrust
  - (b) 1/2 minute at takeoff thrust
2. All mission calculations shall include 5% fuel flow tolerance.
3. BCAV: Best cruise altitude velocity
4. Crew complement: SA-3, ASW-4, VOD-3, Surveillance -4, C (STRIKE) SAR-4; includes Hoist operator and swimmer.

#### 2.0 V/STOL PERFORMANCE

##### A. VERTICAL TAKEOFF (VTO)

1. 89.8° at sea level.
2. WOD - variable direction/velocity, no lift contribution
3. Trimmed flight condition
4. Ratio of net vertical force to takeoff weight = 1.05  
in and out of ground effect
5. Propulsion induced effects and losses due to trim requirements should be accounted for

B. SHORT TAKEOFF (STO)

1. 89.8<sup>0</sup>F at sea level
2. Available deck run distance is for main gear travel
3. Horizontal acceleration at least .065 g after liftoff
4. For aircraft rotation/reconfiguration after liftoff contractor should specify criteria used in defining and constraining the takeoff.

C. TAKEOFF AND LANDING TRANSITION

Transition to wing-borne flight will be accomplished at speeds not less than 120% of power-on stall speed for fully wing-borne flight. In addition, an acceleration of .065 A/G will be possible throughout a (level flight) transition.

APPENDIX B - INSTALLED PROPULSION PERFORMANCE  
OPERATIONAL (1985)

The installed propulsion performance used was developed during the studies. As a result the performance changed as the analysis progressed. Two discreet sets were used. The first set was based on Hamilton-Standard's fan performance linked to a T-55 gas generator. This data was then scaled to approximate the Allison T-701. The installed performance is shown in Figures B-1 to B-10. A 62 inch diameter fan is used with the appropriate engine size. A 5% fuel allowance, for service tolerance is included. During this same period, the static performance at sea level and 90°F was:

2 Engines/3 Fans; Intermediate Rating, F = 34000 lb.

1 Engine/3 Fans, contingency rating, F = 24500 lbs.

Figures B-1 to B-5 show fuel flow vs. net thrust at altitudes of 0, 10,000, 20,000, 30,000 and 40,000 feet. Figures B-6 to B-10 show ram drag as a function of gross thrust for the same conditions.

The second set of data was received from Allison in June 1975. The developed version of the T-701 was called PD 370-15. The installed thrust and fuel flows used to calculate the multi-mission airplane performance is shown in Figures B-11 to B-22. Installation losses are summarized on Table B-1.

#### Technology Airplane

The installed performance for the technology airplane is based on minor modification to the current T-701 with the operational 62 inch fans. This engine was designated PD 370-16. The contingency rating was augmented by the use of water/alcohol injection. The performance is given in Figures B-24 to B-35. The installation losses given in Table B-1 apply.

TABLE B-1  
 INSTALLATION LOSSES  
 (MULTI-MISSION AIRPLANES)

Inlet Recovery	.992 @ V = 100 KTS .998 @ V = 100 KTS		
Transmission loss	4% of required fan power		
Power Extraction per Airplane	V <sub>LAND</sub> , Emergency	=	23 HP
	V <sub>LAND</sub> , Normal	=	200 HP
	STOL Takeoff	=	200 HP
	Climb (Intermediate)	=	200 HP
	Max. Cruise and below	=	143 HP
Engine Bleed	0		
Nozzle C <sub>v</sub> 's	Figure B-23		



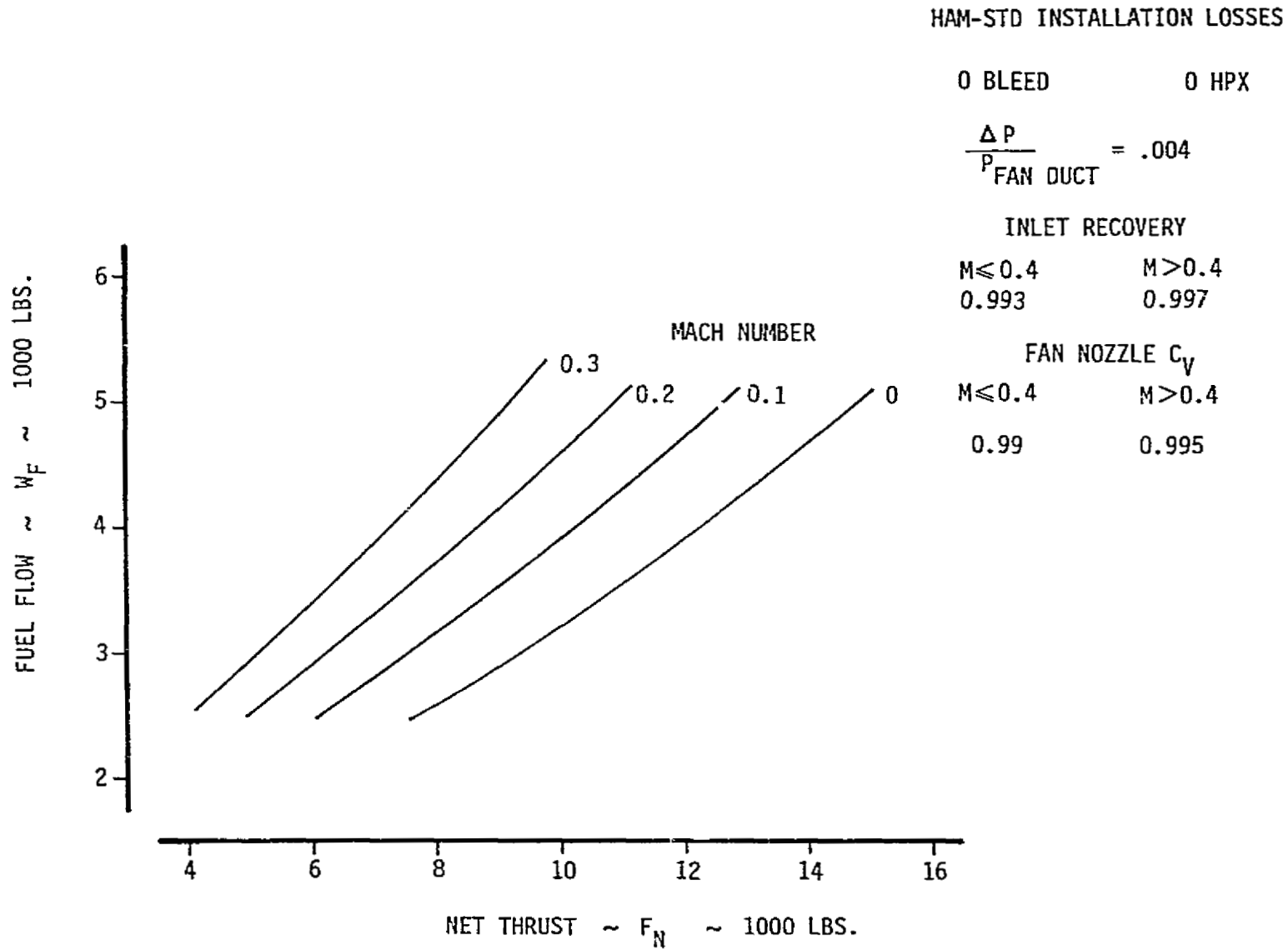

Figure B-1.-Cruise Performance Sea Level Standard Day

CRUISE PERFORMANCE

STD DAY

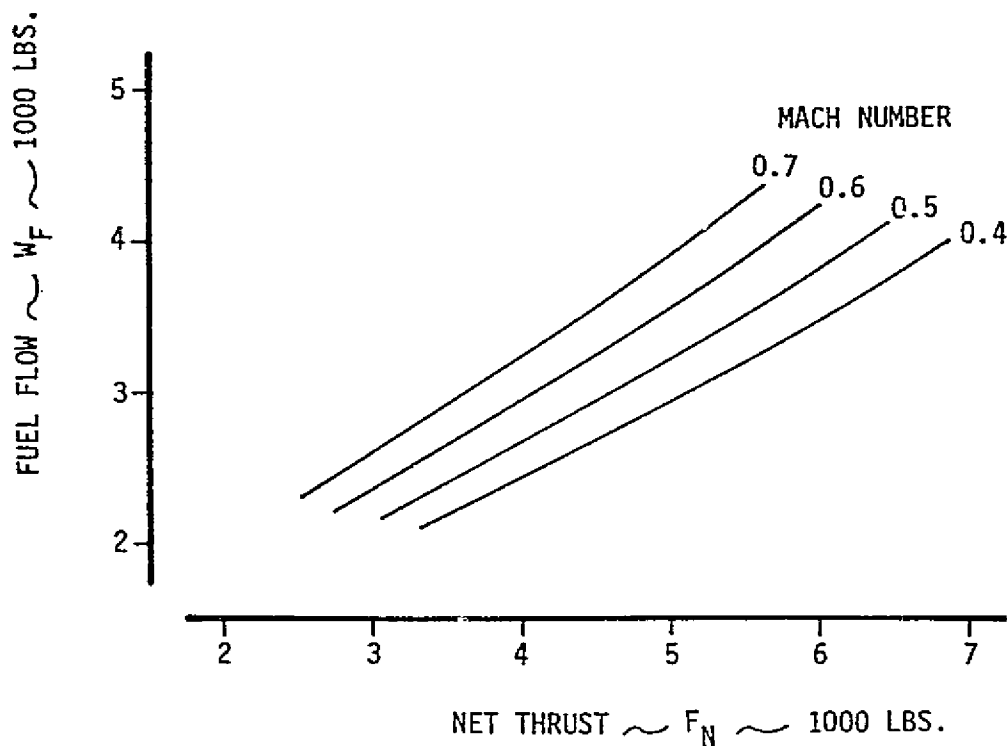

Figure B-2.—Cruise Performance 10,000-ft Standard Day

HAM-STD INSTALLATION LOSSES

0 BLEED            0 HPX

$$\frac{\Delta P}{P_{\text{FAN DUCT}}} = .004$$

INLET RECOVERY

M ≤ 0.4            M > 0.4  
 0.993              0.997

FAN NOZZLE C<sub>v</sub>  
 M ≤ 0.4            M > 0.4  
 0.99                0.995

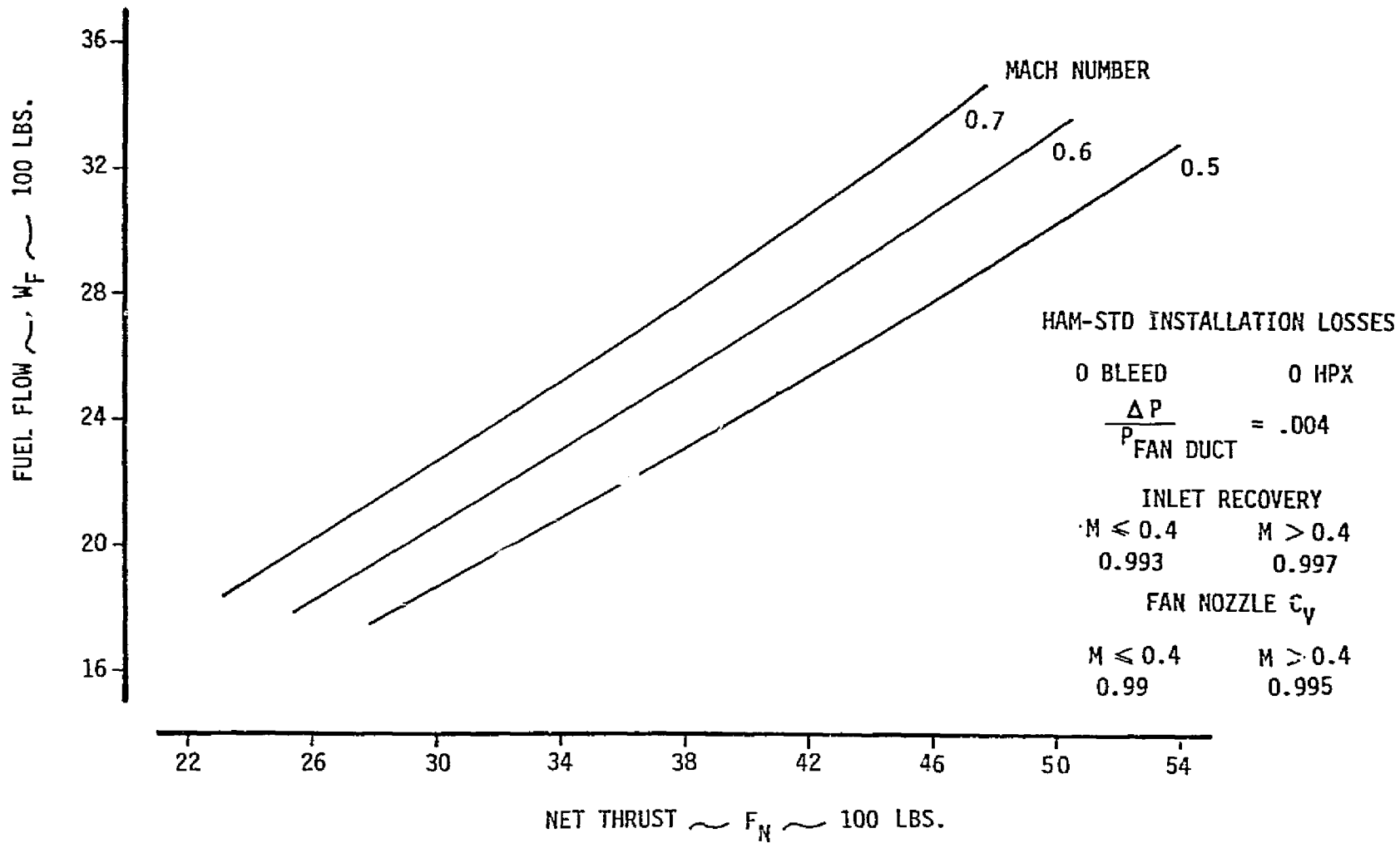
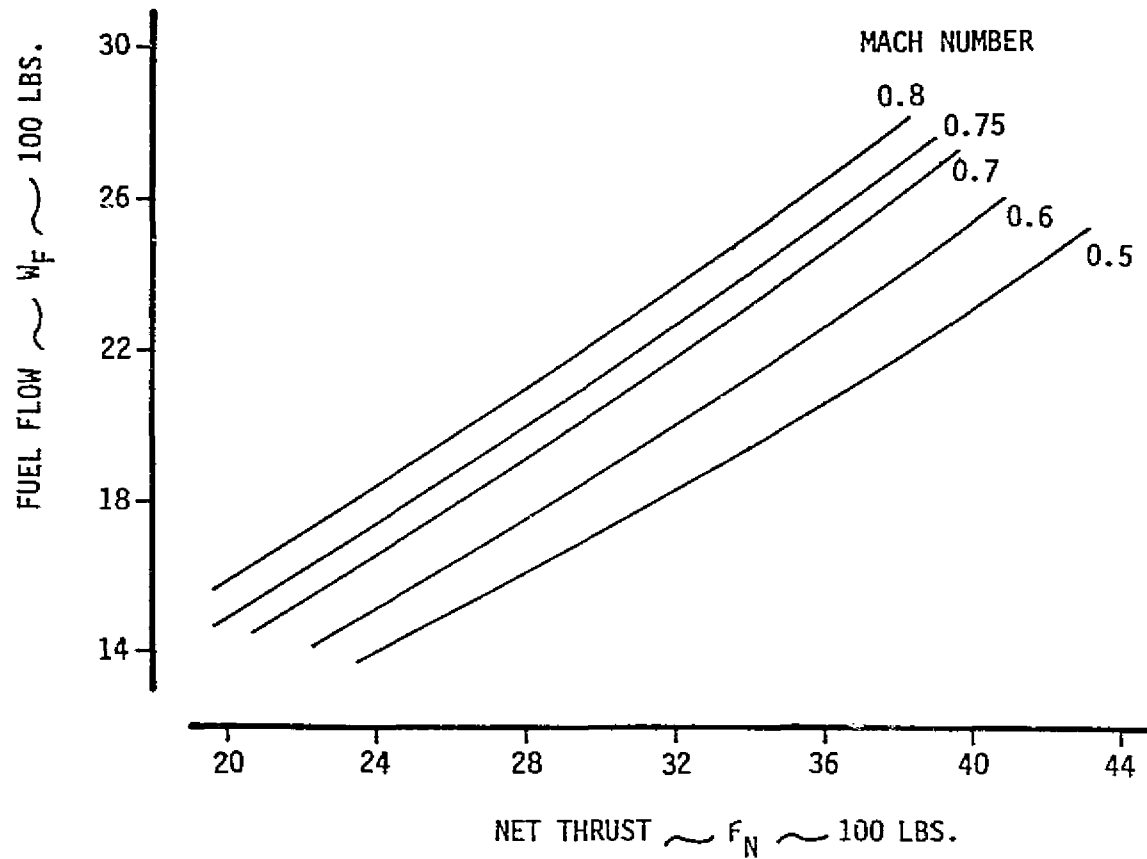

Figure B-3.—Cruise Performance 20,000-ft Standard Day



HAM-STD INSTALLATION LOSSES

0 BLEED            0 HPX  
 $\frac{\Delta P}{P_{\text{FAN DUCT}}} = .004$

INLET RECOVERY

M ≤ 0.4	M > 0.4
0.993	0.997

FAN NOZZLE C<sub>v</sub>

M ≤ 0.4	M > 0.4
0.99	0.995

Figure B-4.—Cruise Performance 30,000-ft Standard Day

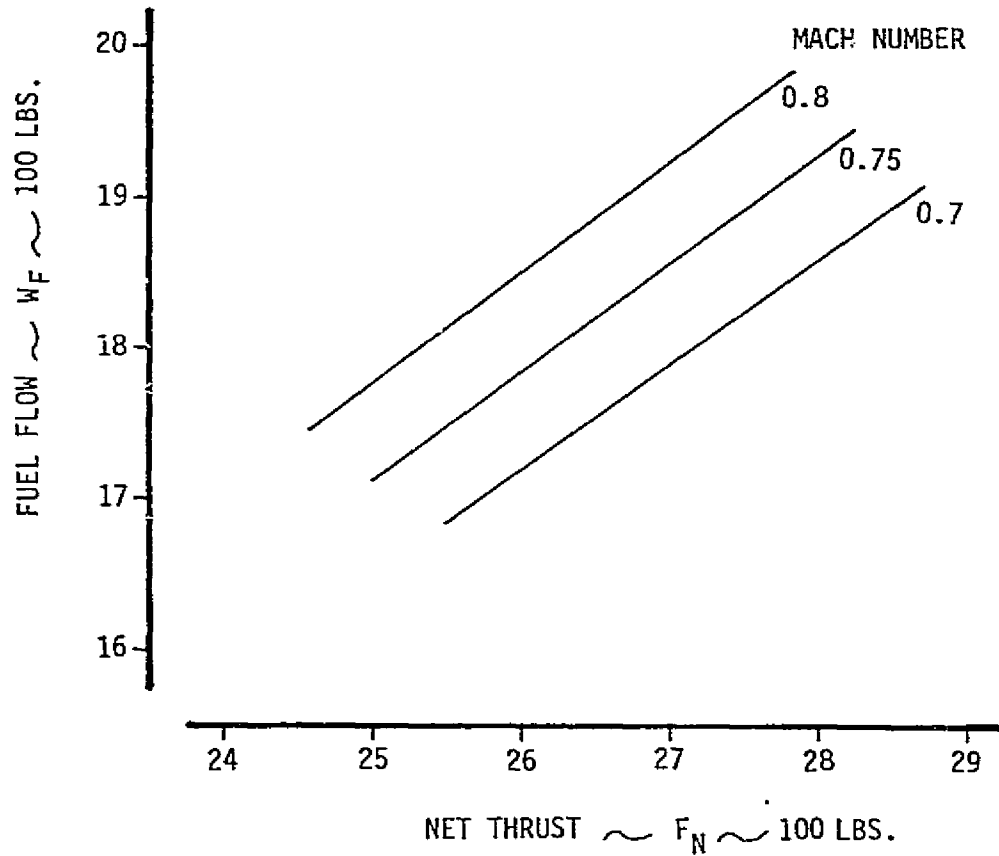

Figure B-5.-Cruise Performance 40,000-ft Standard Day

HAM-STD INSTALLATION LOSSES

0 BLEED                      0 HPX  

$$\frac{\Delta P}{P_{\text{FAN DUCT}}} = .004$$

INLET RECOVERY

M ≤ 0.4	M > 0.4
0.993	0.997

FAN NOZZLE C<sub>v</sub>

M ≤ 0.4	M > 0.4
0.99	0.995

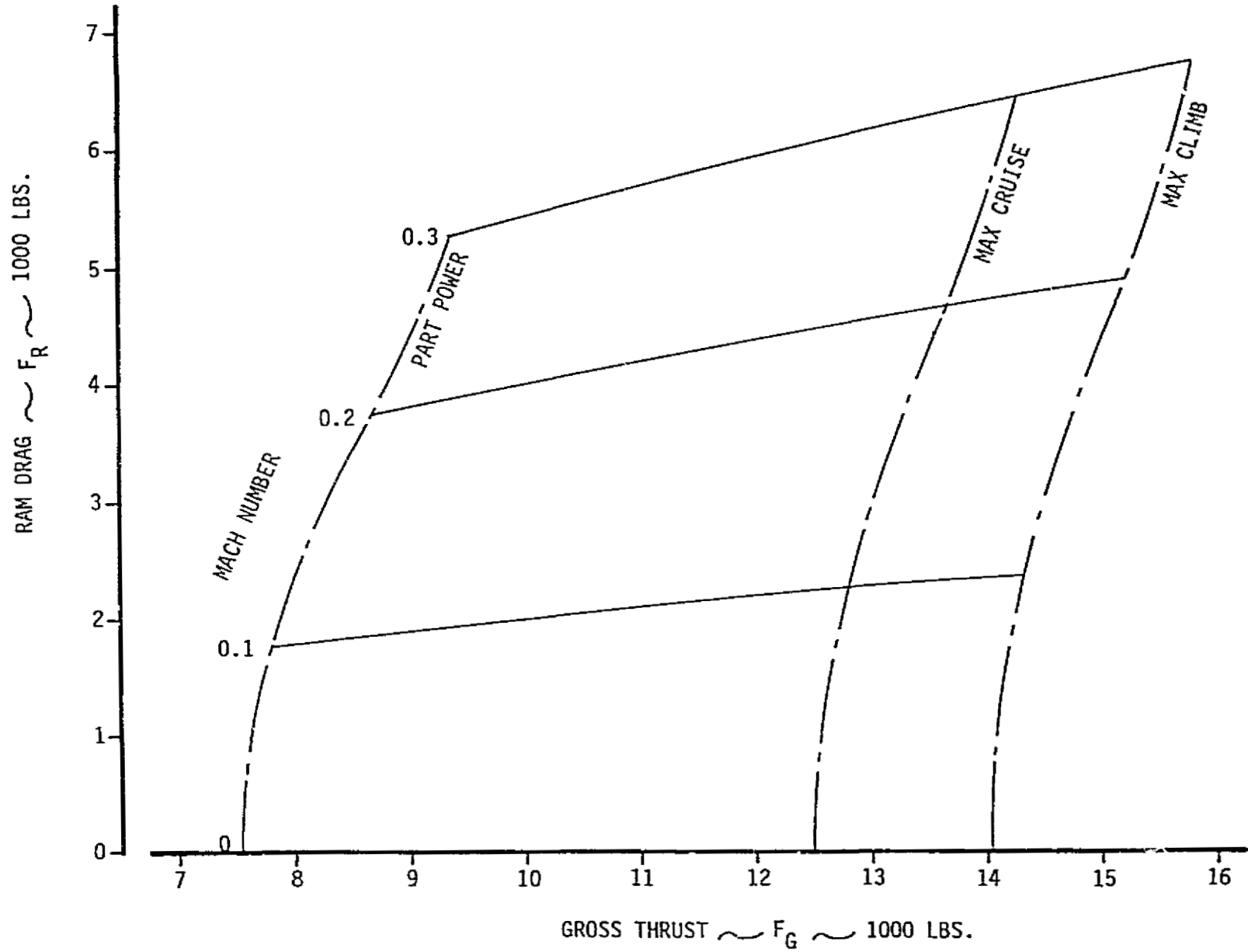

Figure B-6.--Cruise Performance Sea Level Standard Day

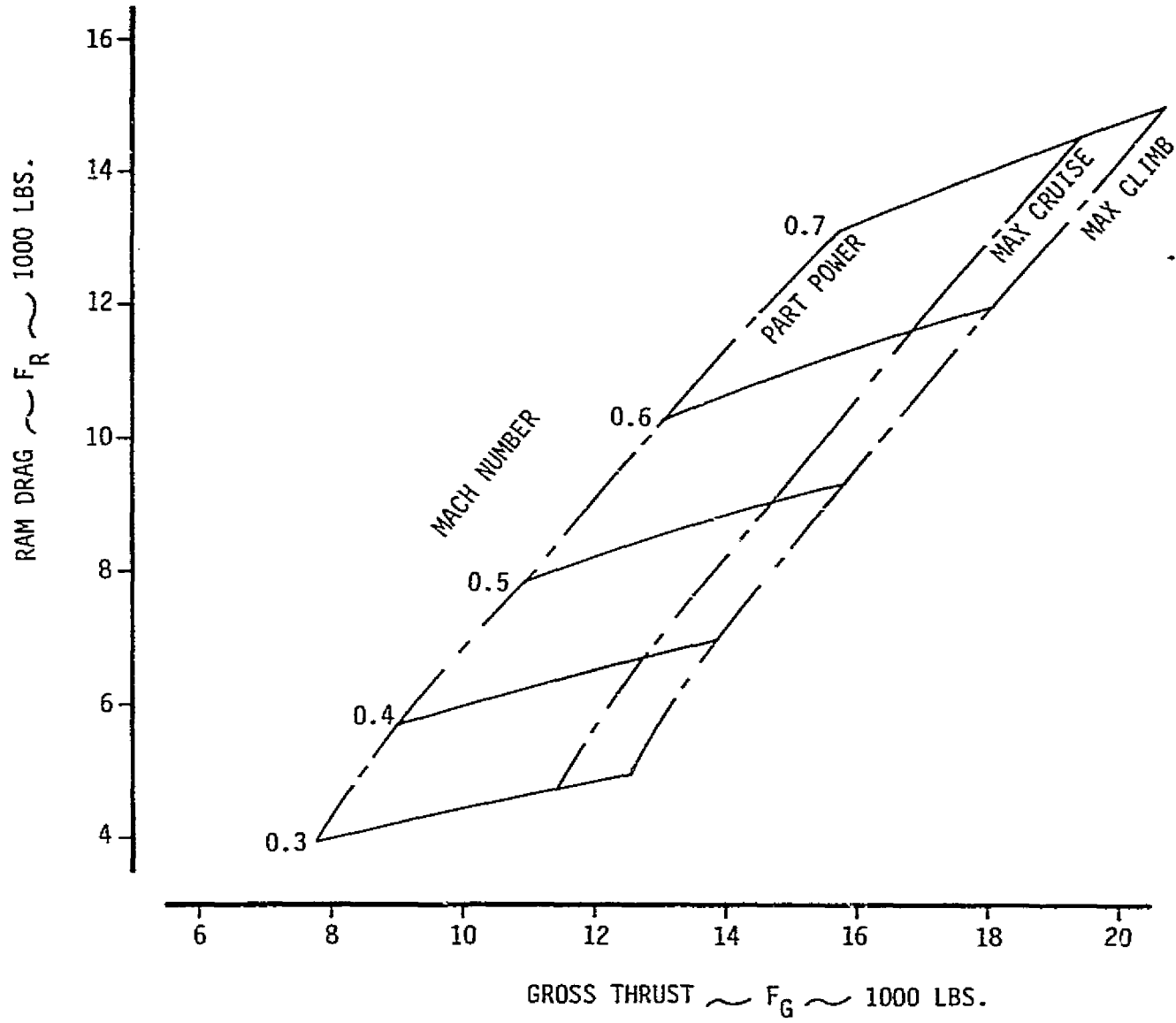

Figure B-7.-Cruise Performance 10,000-ft Standard Day

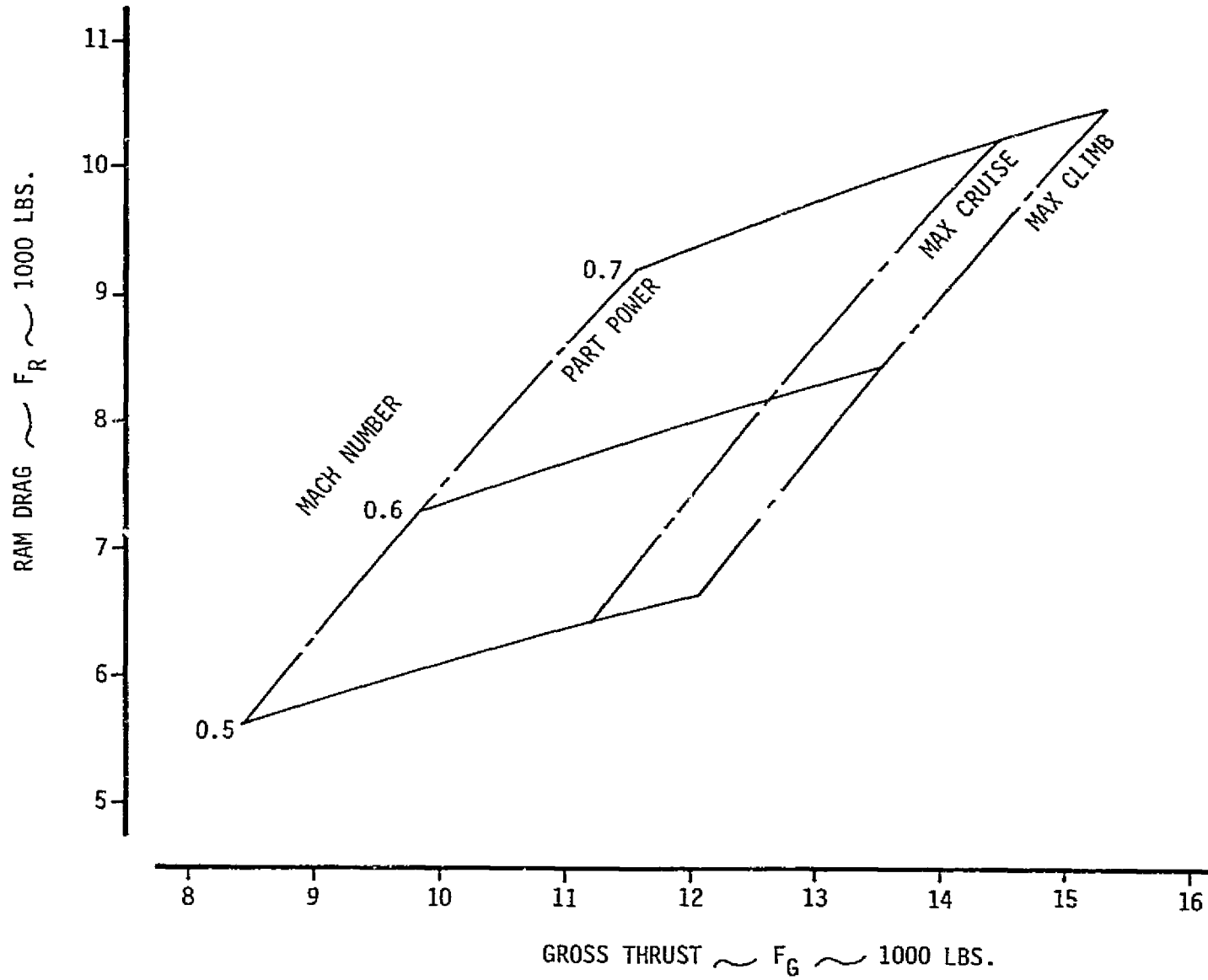

Figure B-8.-Cruise Performance 20,000-ft Standard Day



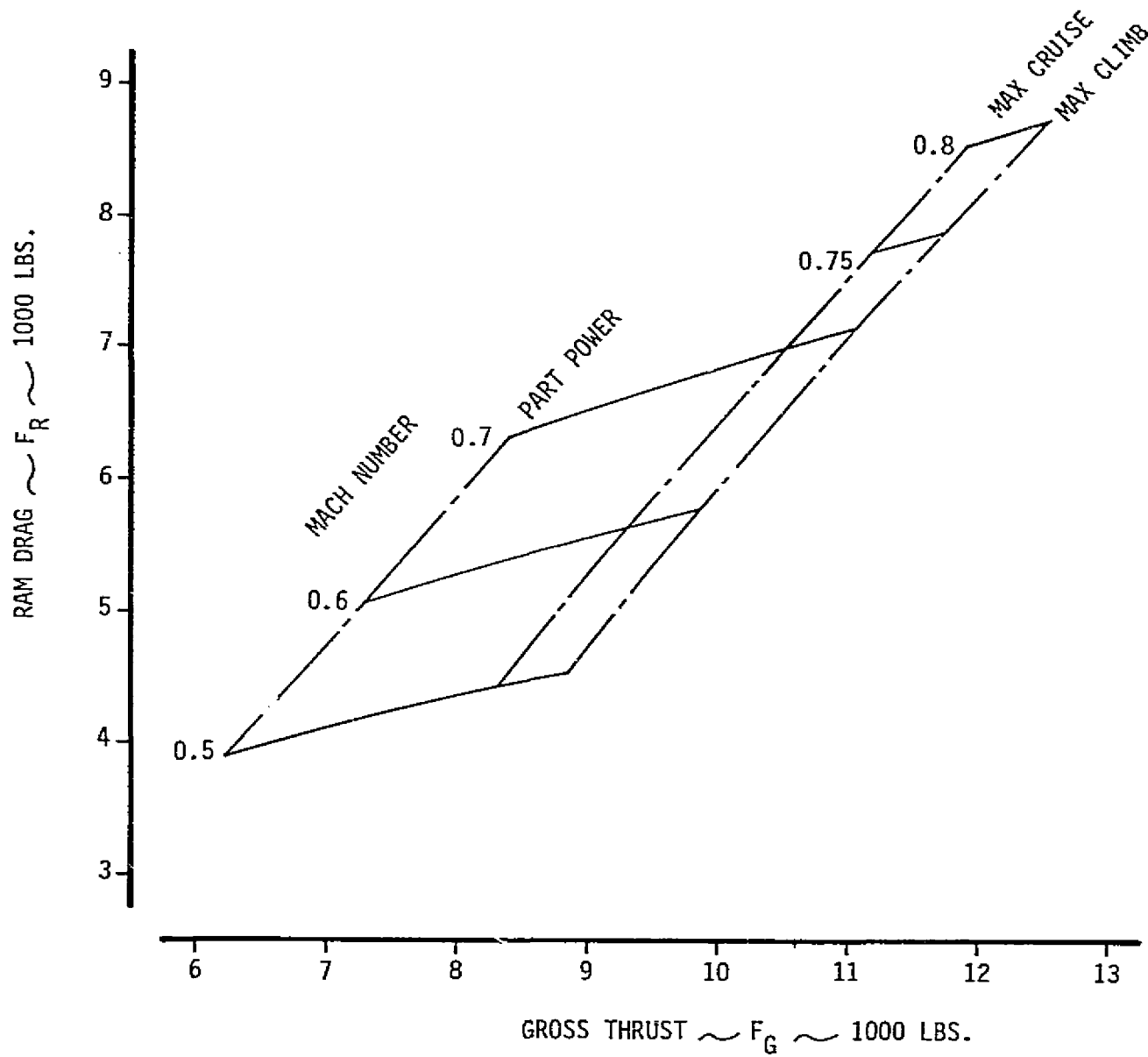

Figure B-9.—Cruise Performance 30,000-ft Standard Day

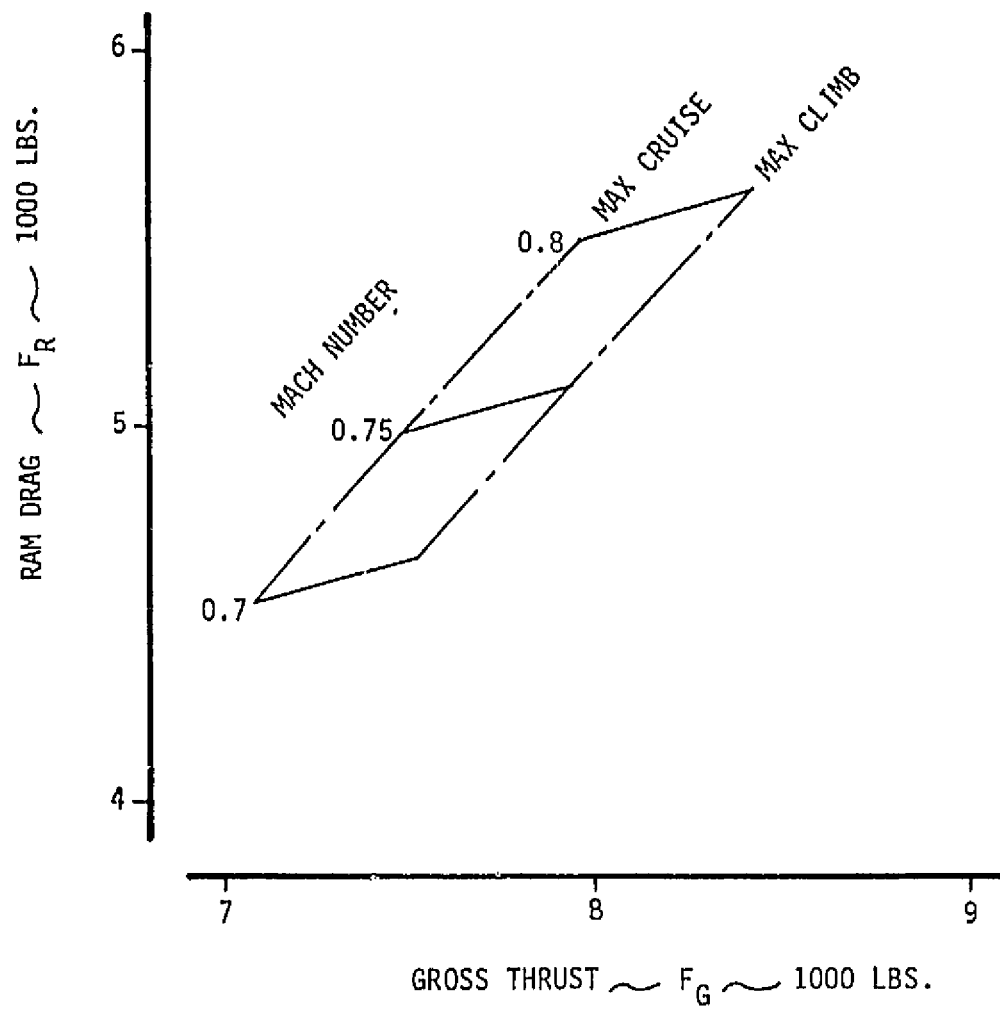

Figure B-10.—Cruise Performance 40,000-ft Standard Day

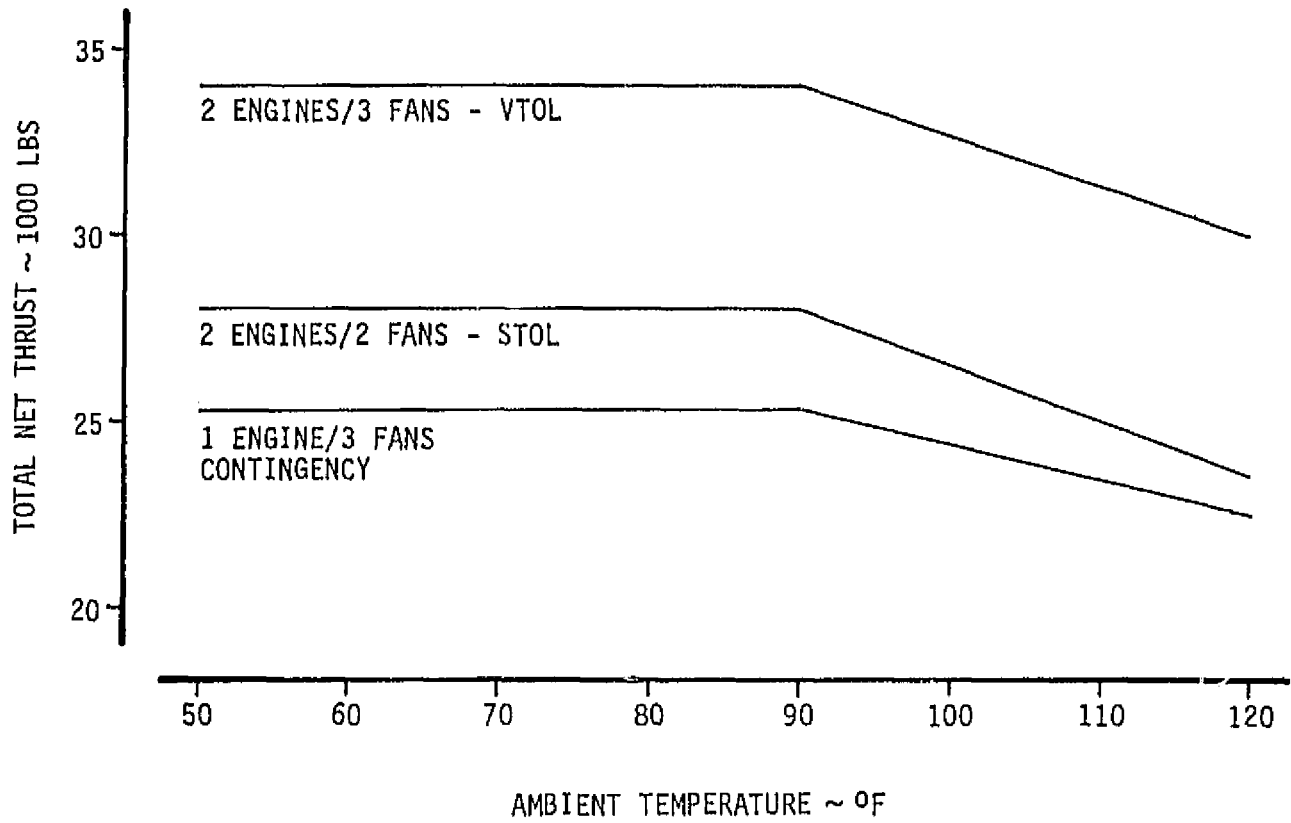

Figure B-11.-Allison PD370-15 Installed Performance

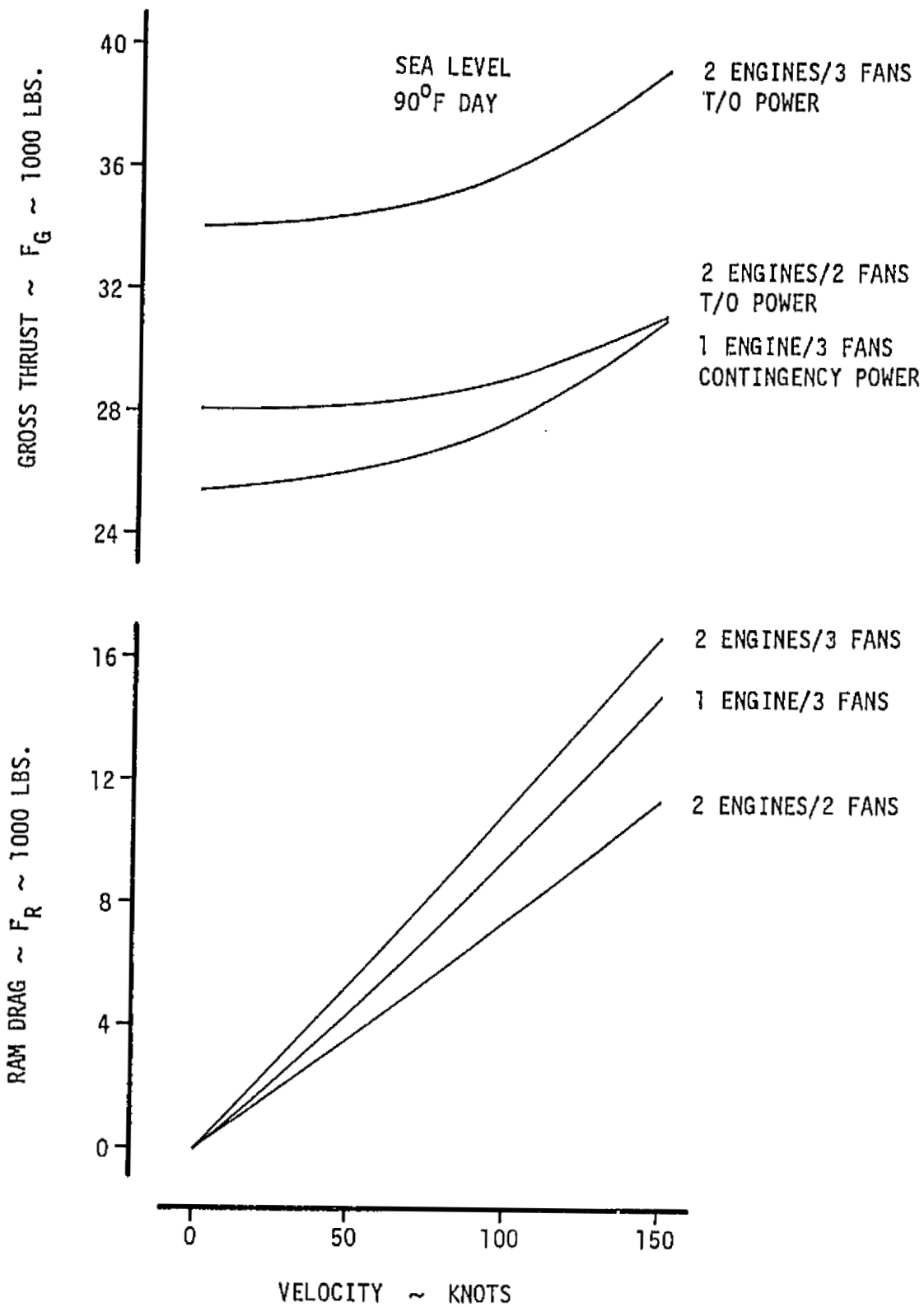

Figure B-12.—Allison PD370-15 Installed Performance

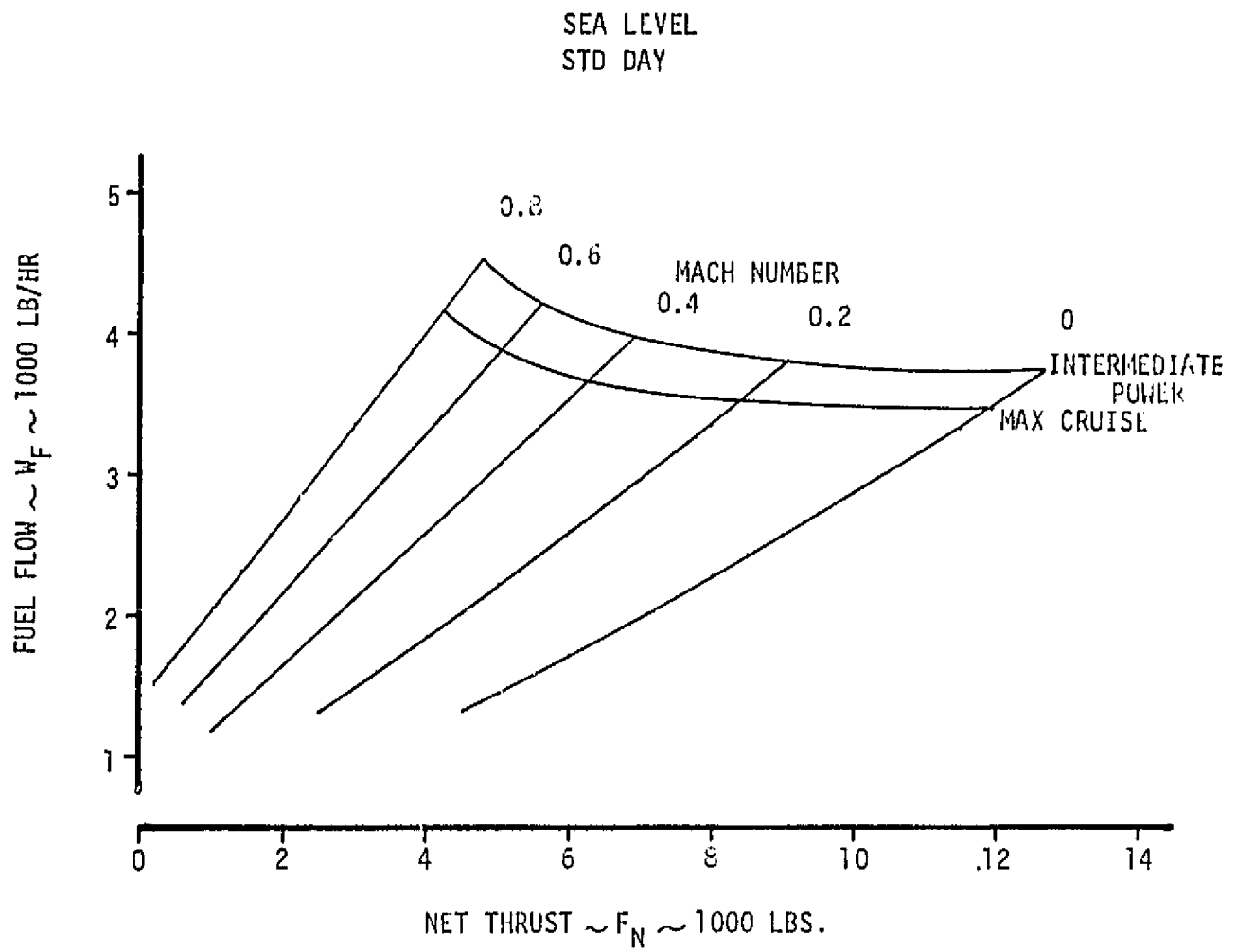

Figure B-13.—Allison PD370-15 Installed Cruise Performance Sea Level

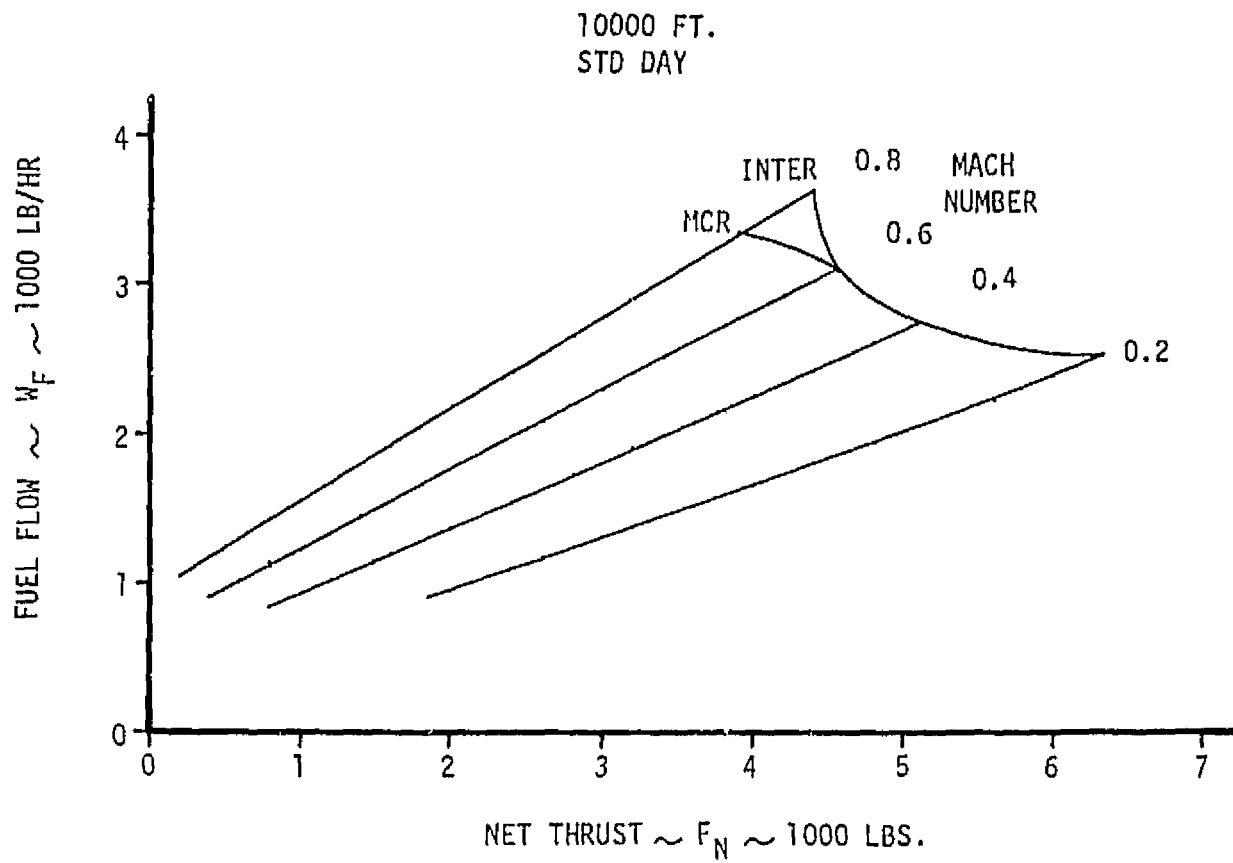

Figure B-14.—Allison PD370-15 Installed Cruise Performance 10,000-ft

20000 FT.  
STD DAY

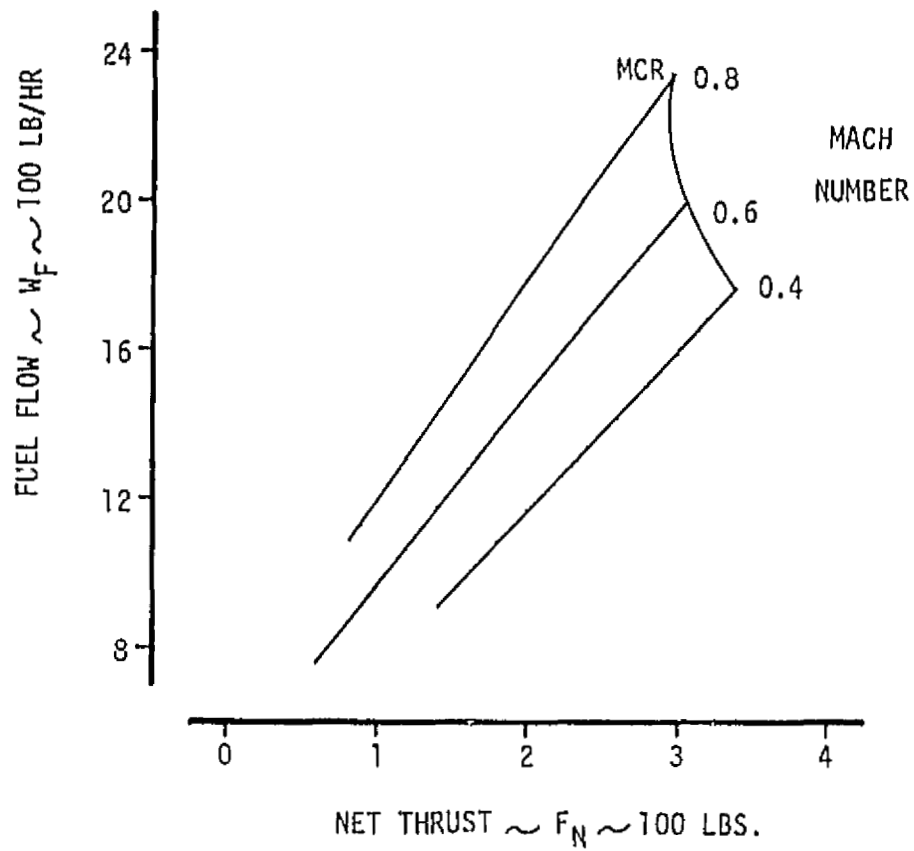

Figure B-15.—Allison PD370-15 Installed Cruise Performance 20,000-ft

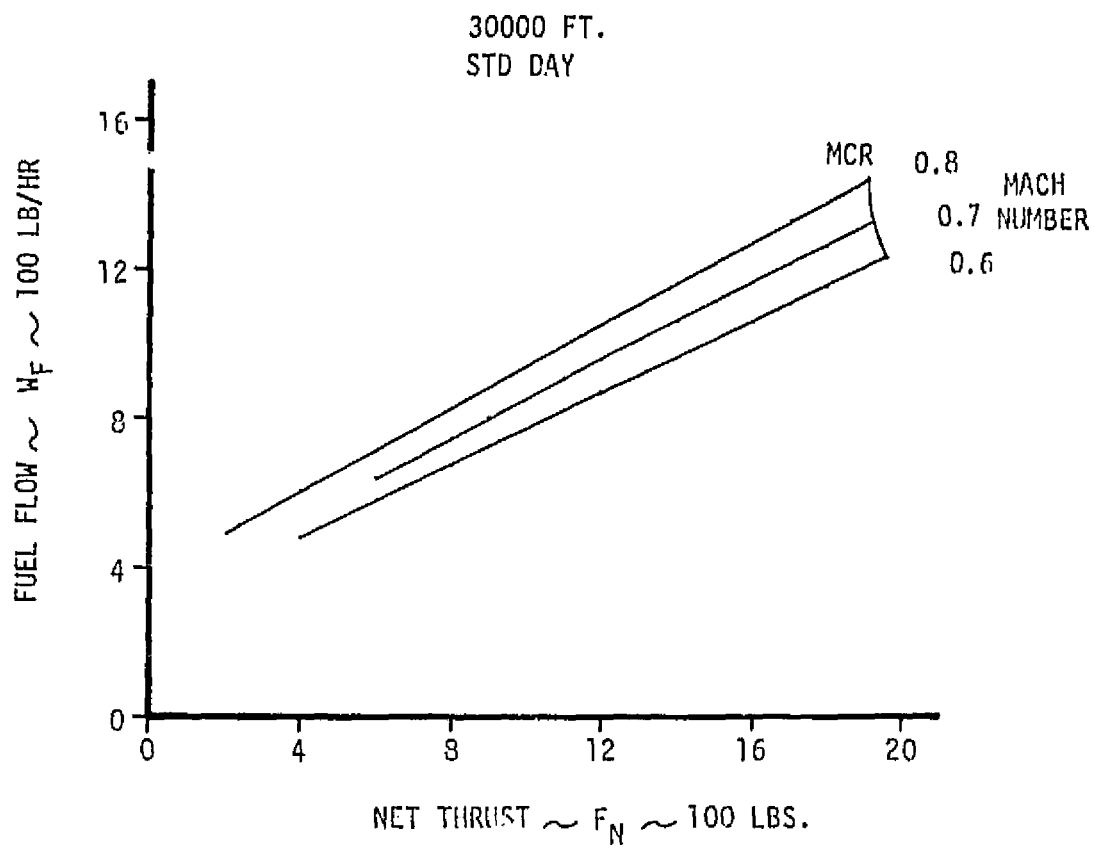

Figure B-16.—Allison PD370-15 Installed Cruise Performance 30,000-ft



40000 FT.  
STD DAY

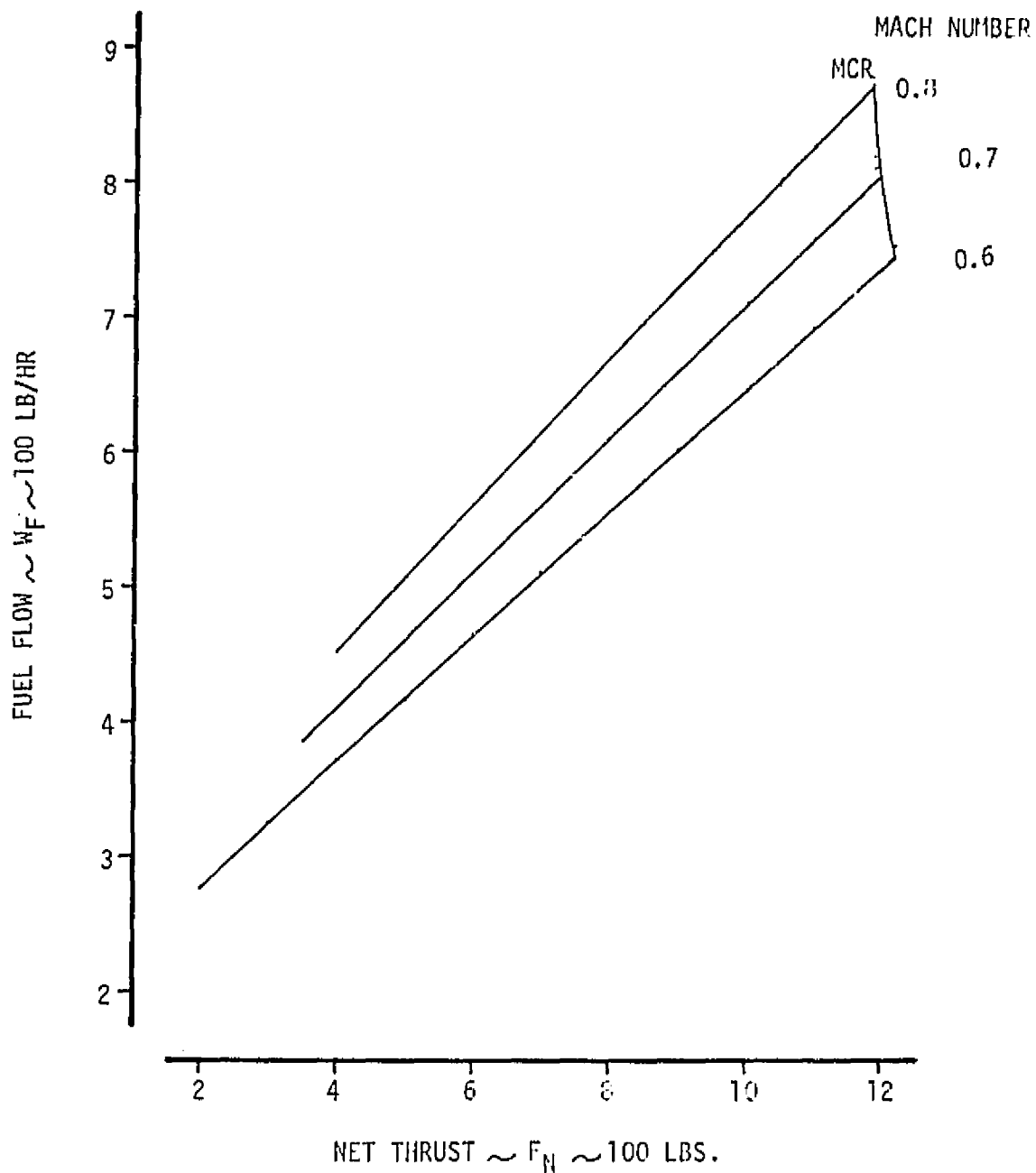

Figure B-17.-Allison PD370-15 Installed Cruise Performance 40,000 ft

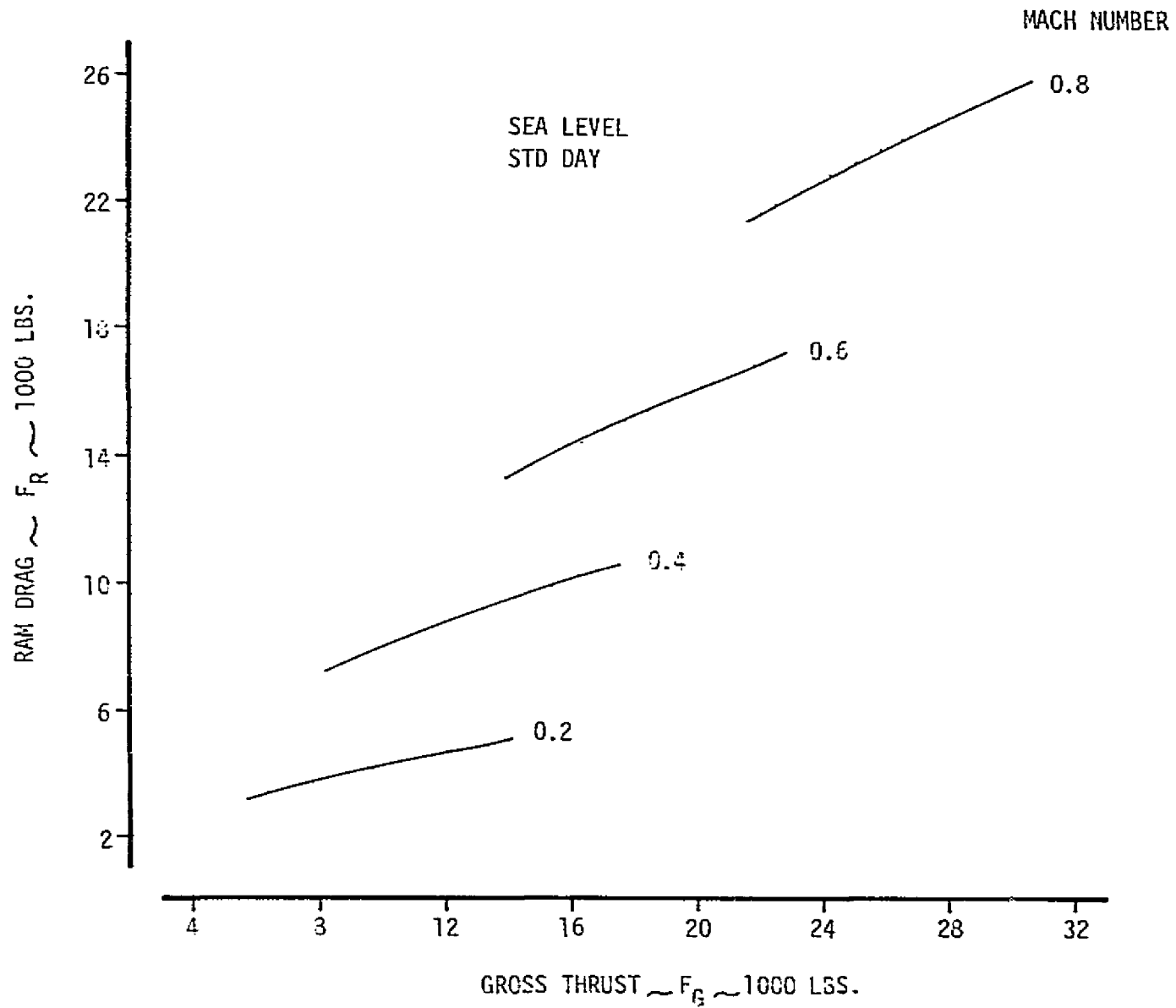

Figure B-18.—Allison PD270-15 Installed Cruise Performance Sea Level

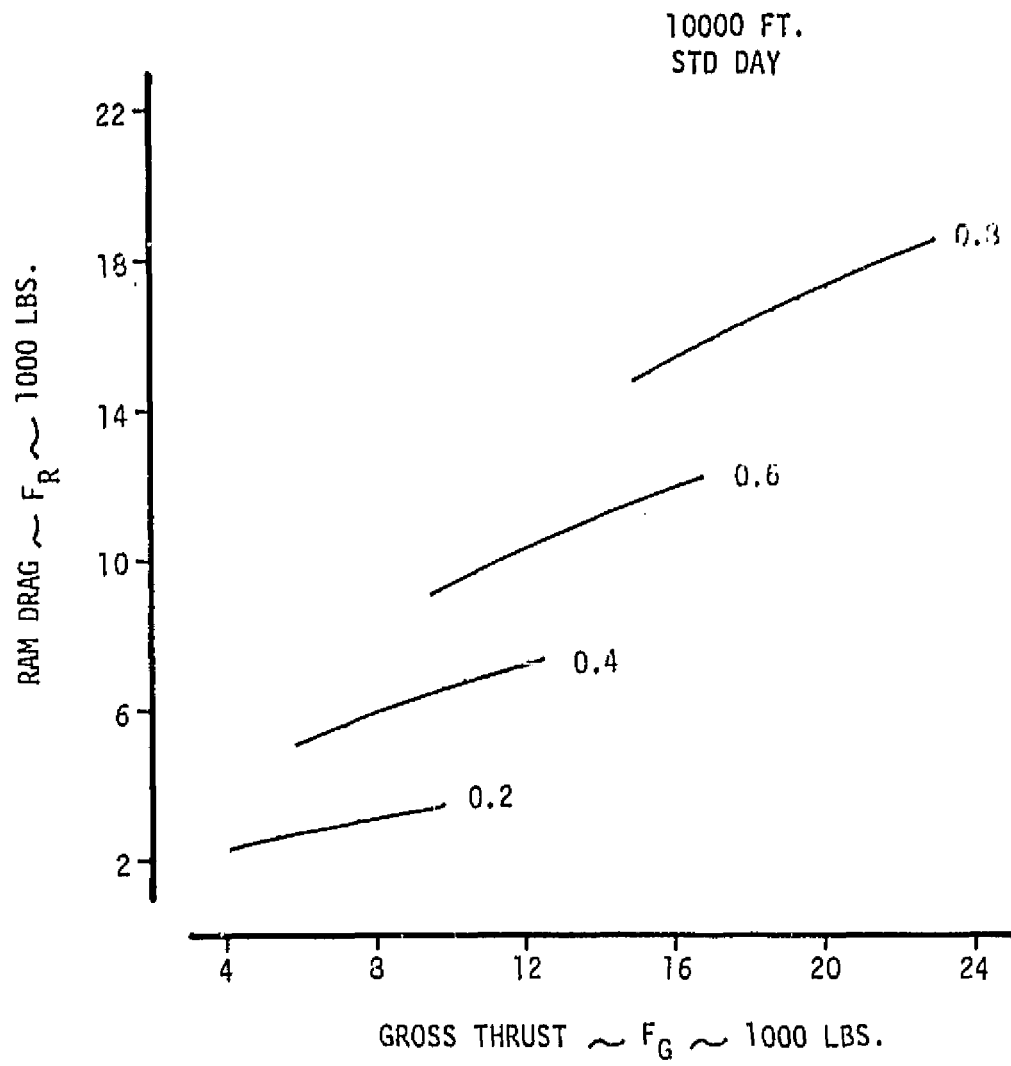

Figure B-19.-Allison PD370-15 Installed Cruise Performance 10,000 ft

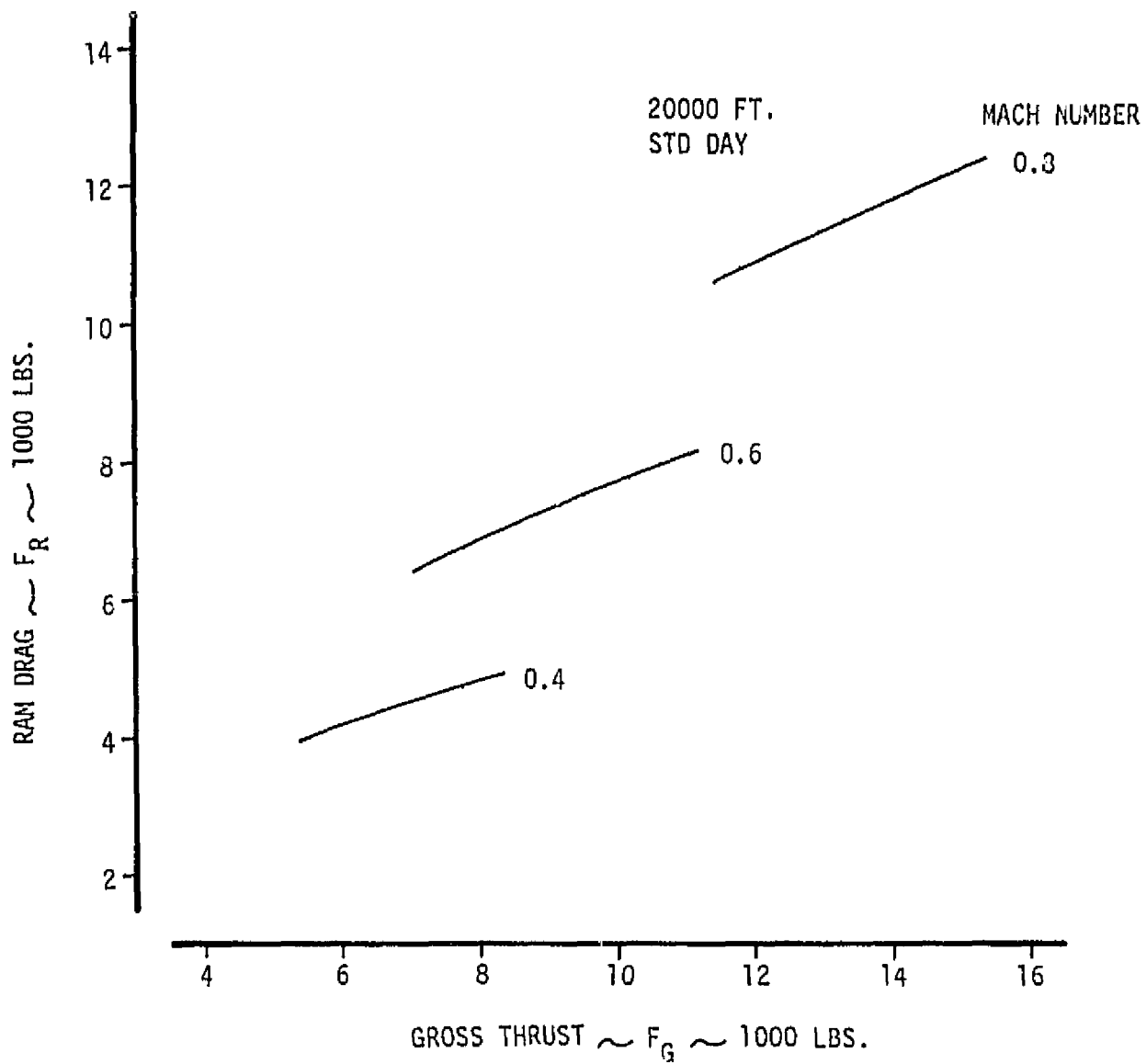

Figure B-20.--Allison PD370-15 Installed Cruise Performance 20,000 ft

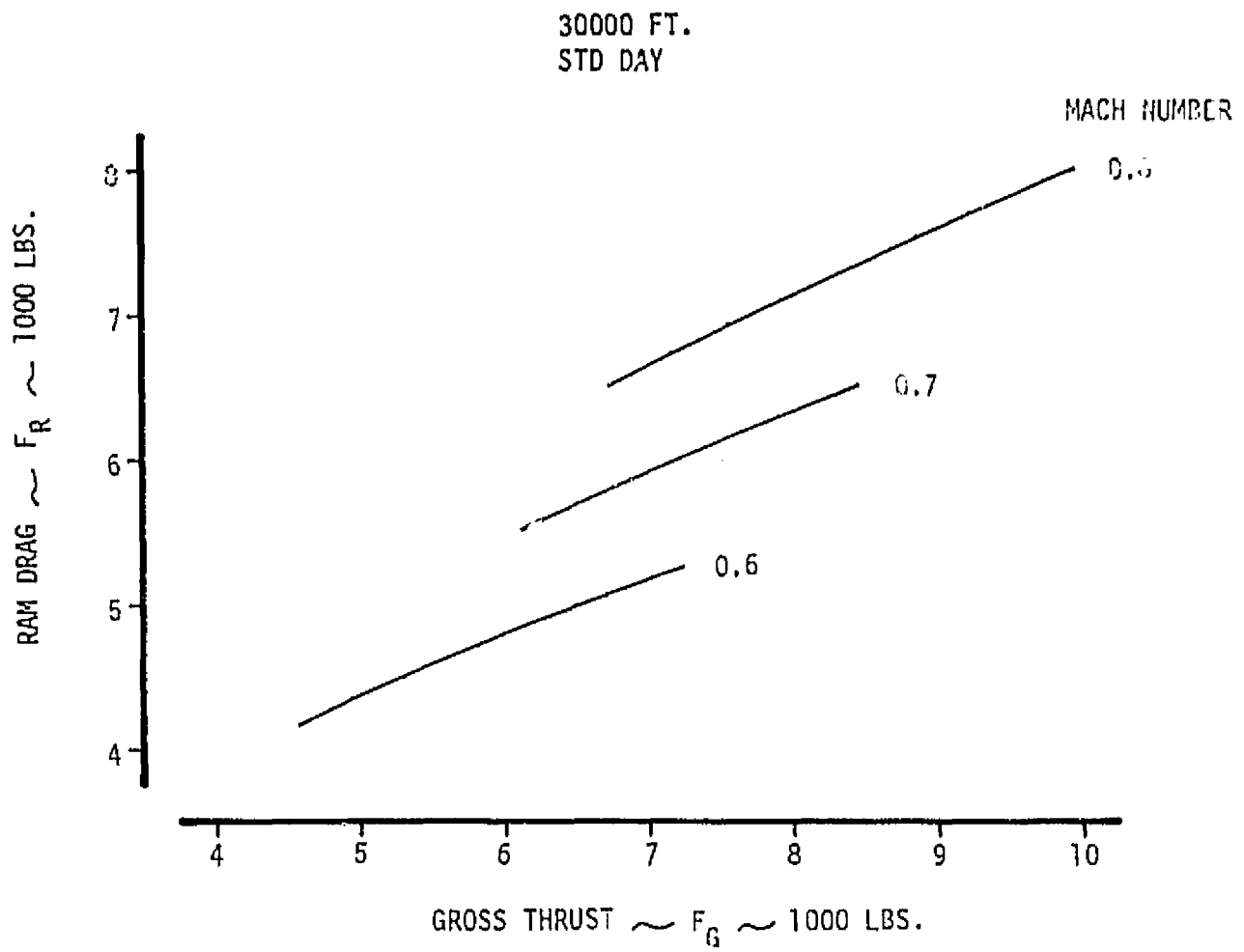

Figure B-21.—Allison PD370-15 Installed Cruise Performance 30,000 ft

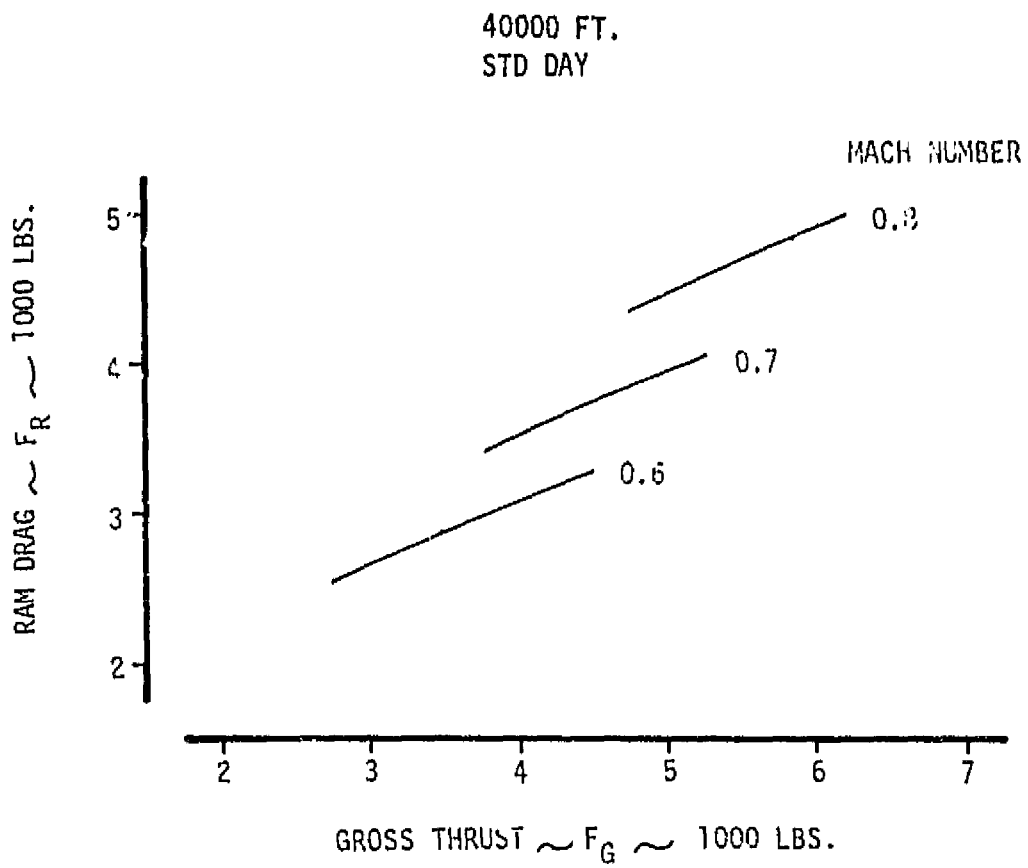

Figure B-22.—Allison PDS70-15 Installed Cruise Performance 40,000 ft

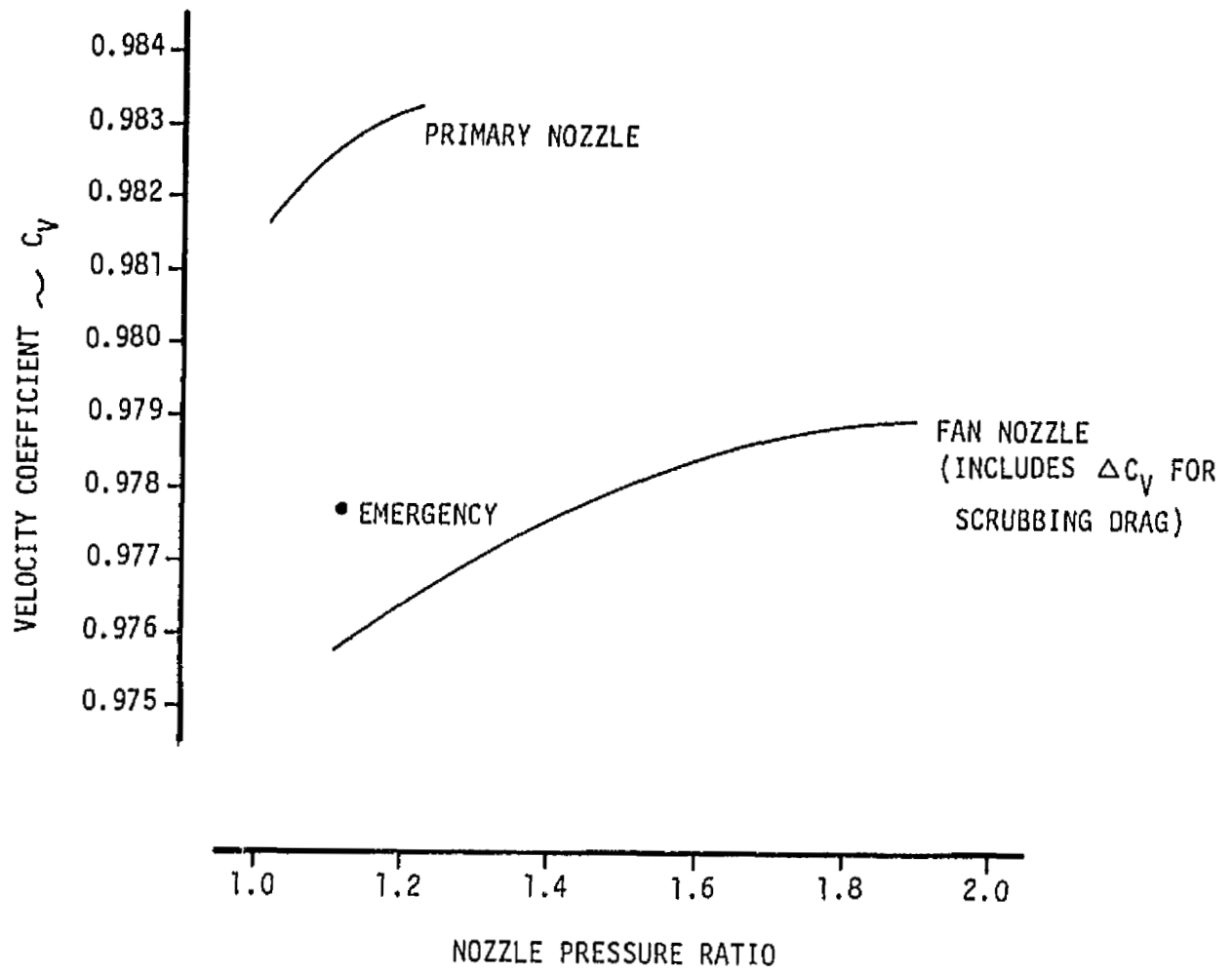

Figure B-23.—Nozzle Velocity Coefficients

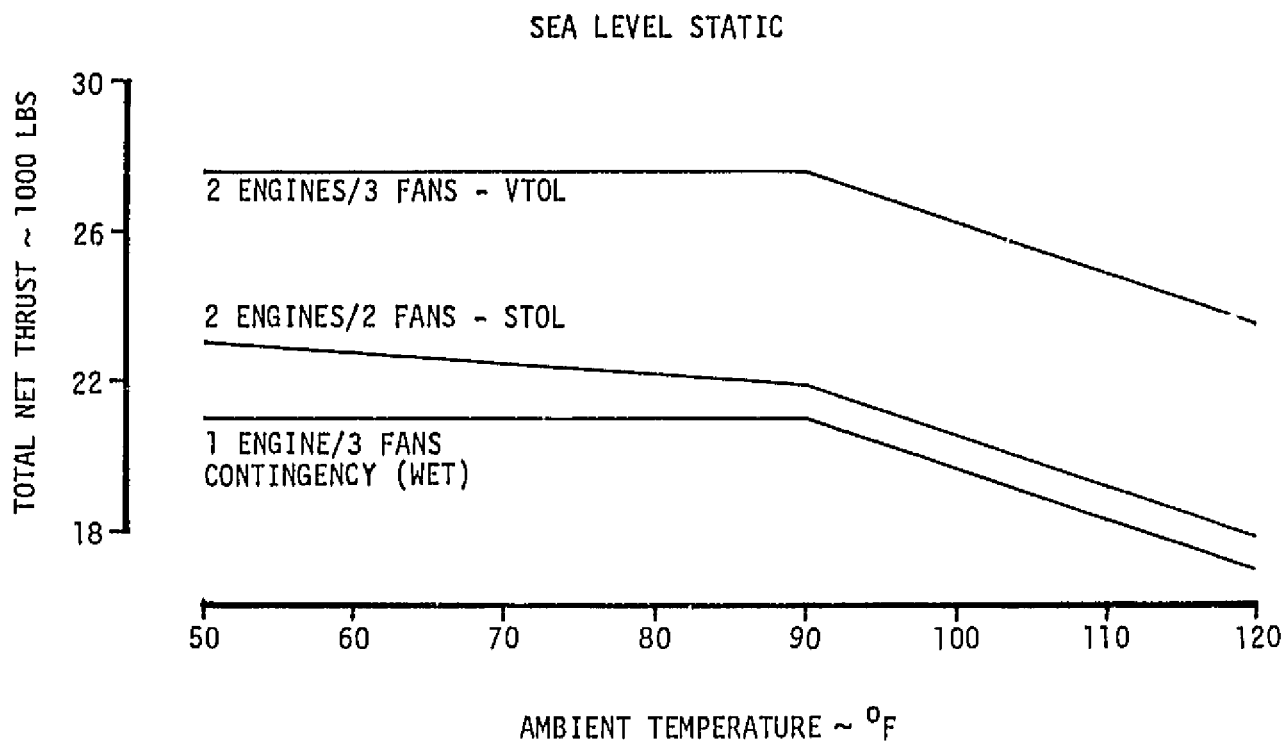

Figure B-24.--Allison PD370-16 Installed Performance



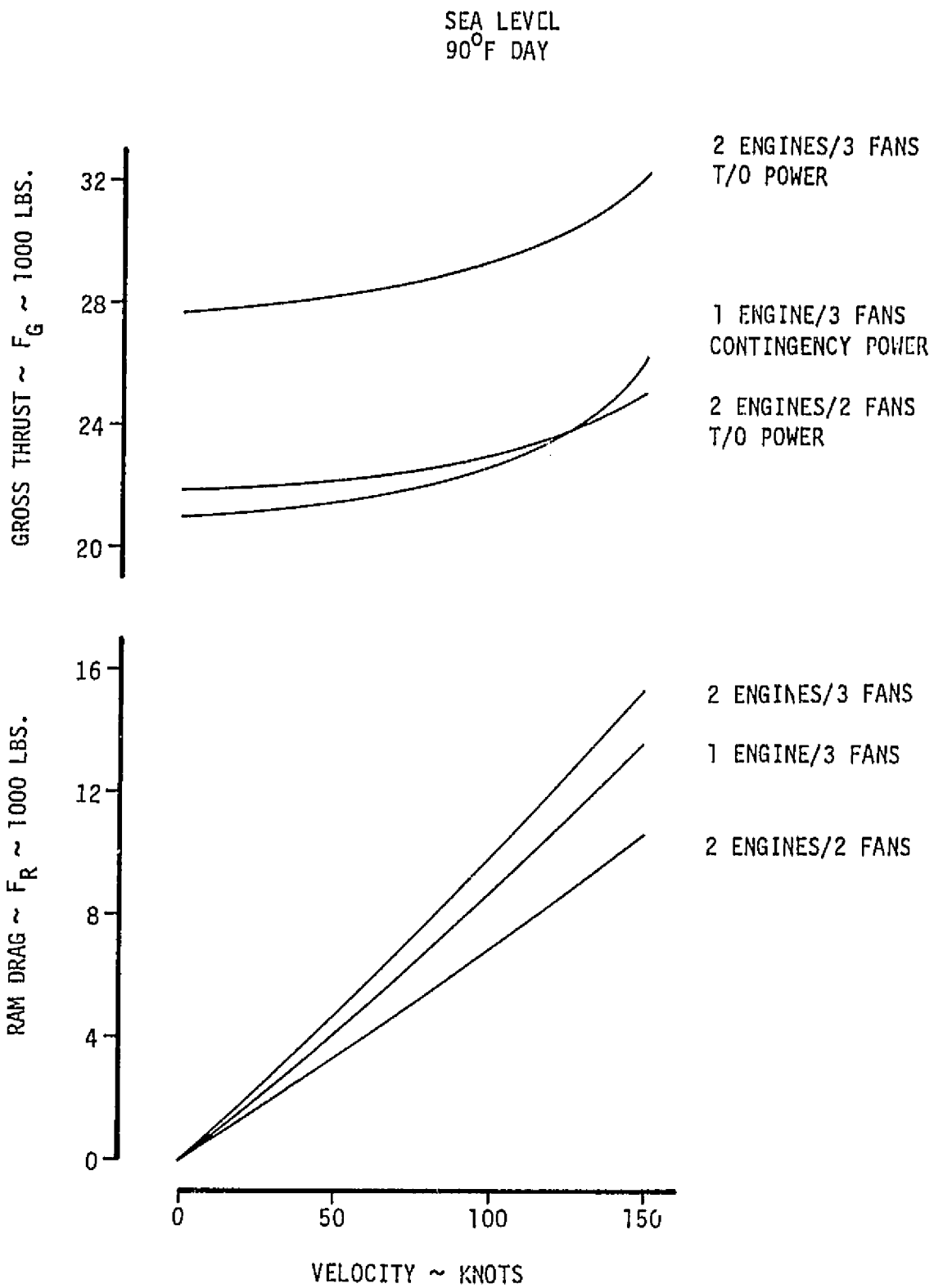

Figure B-25.—Allison PD370-16 Installed Performance

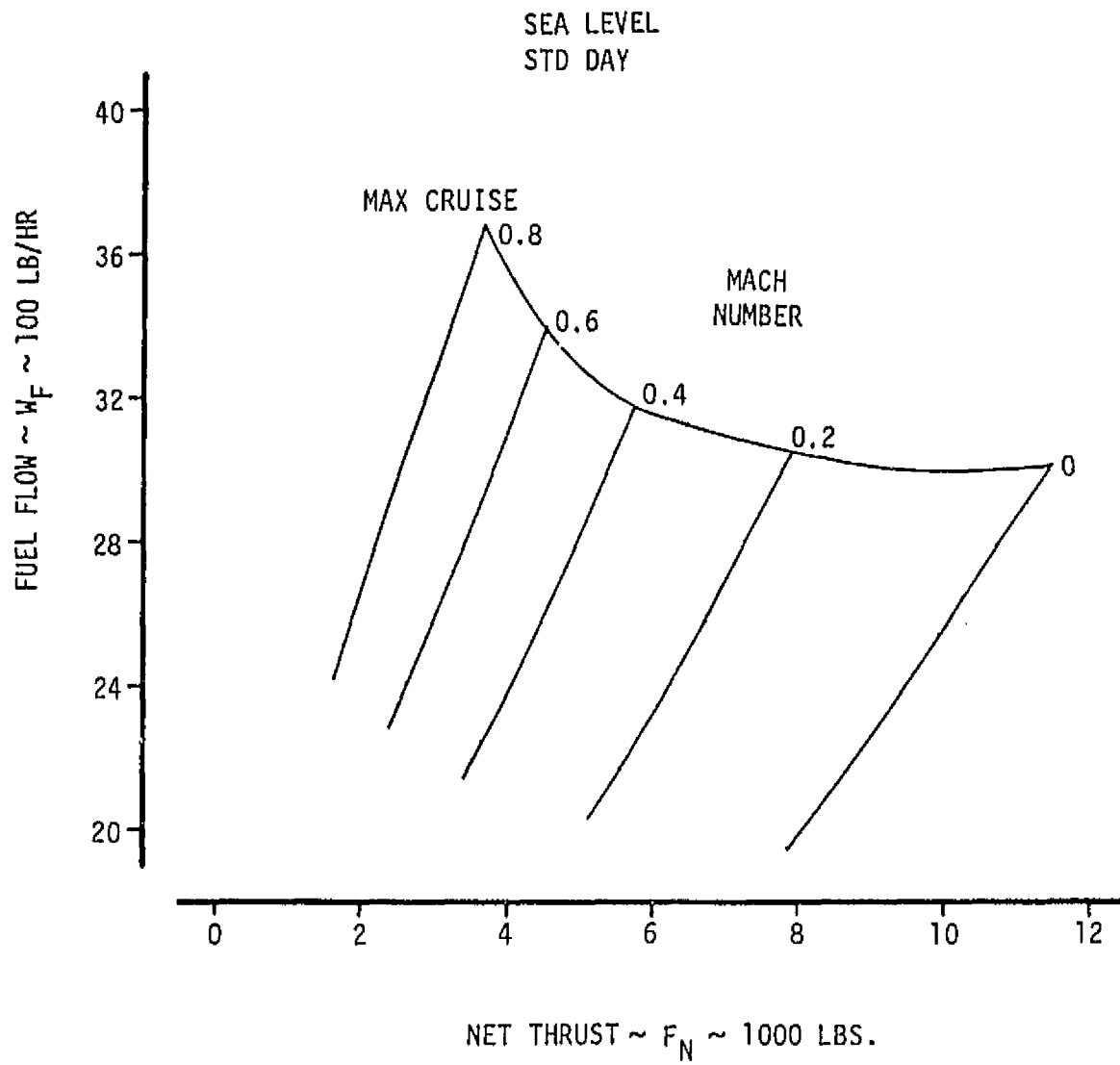

Figure B-26.-Allison PD370-16 Installed Cruise Performance Sea Level

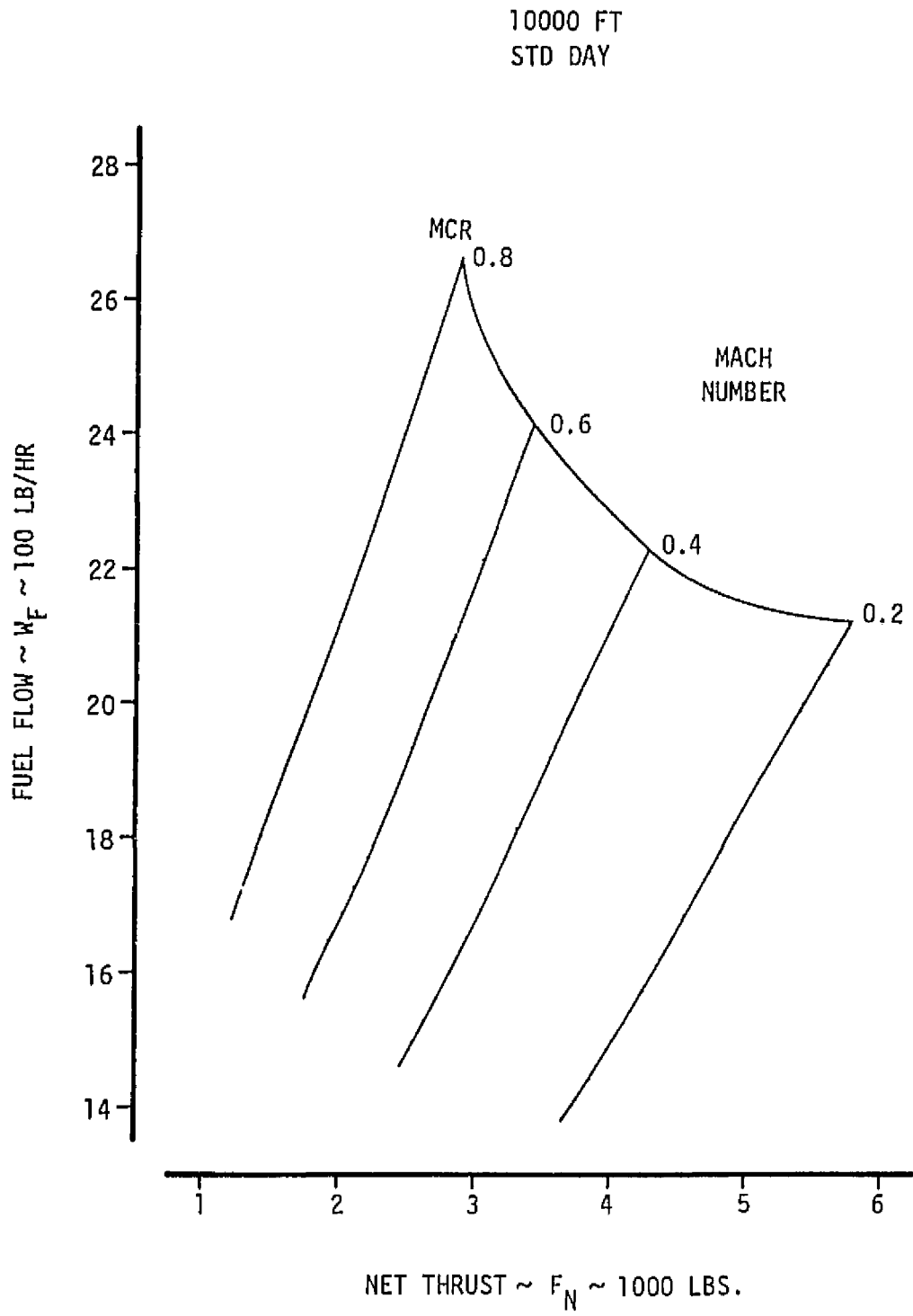

Figure B-27.-Allison PD370-16 Installed Cruise Performance 10,000 ft

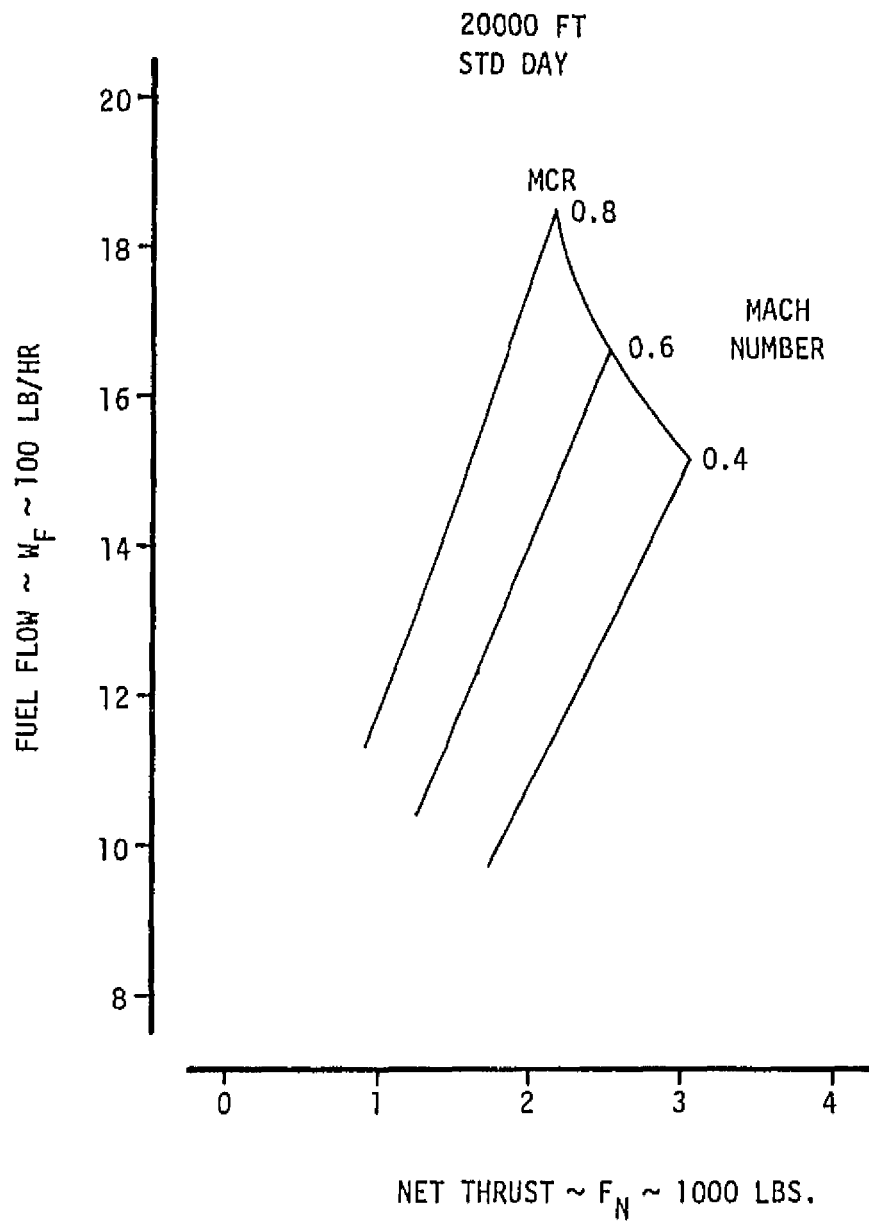

Figure B-28.—Allison PD370-16 Installed Cruise Performance 20,000 ft

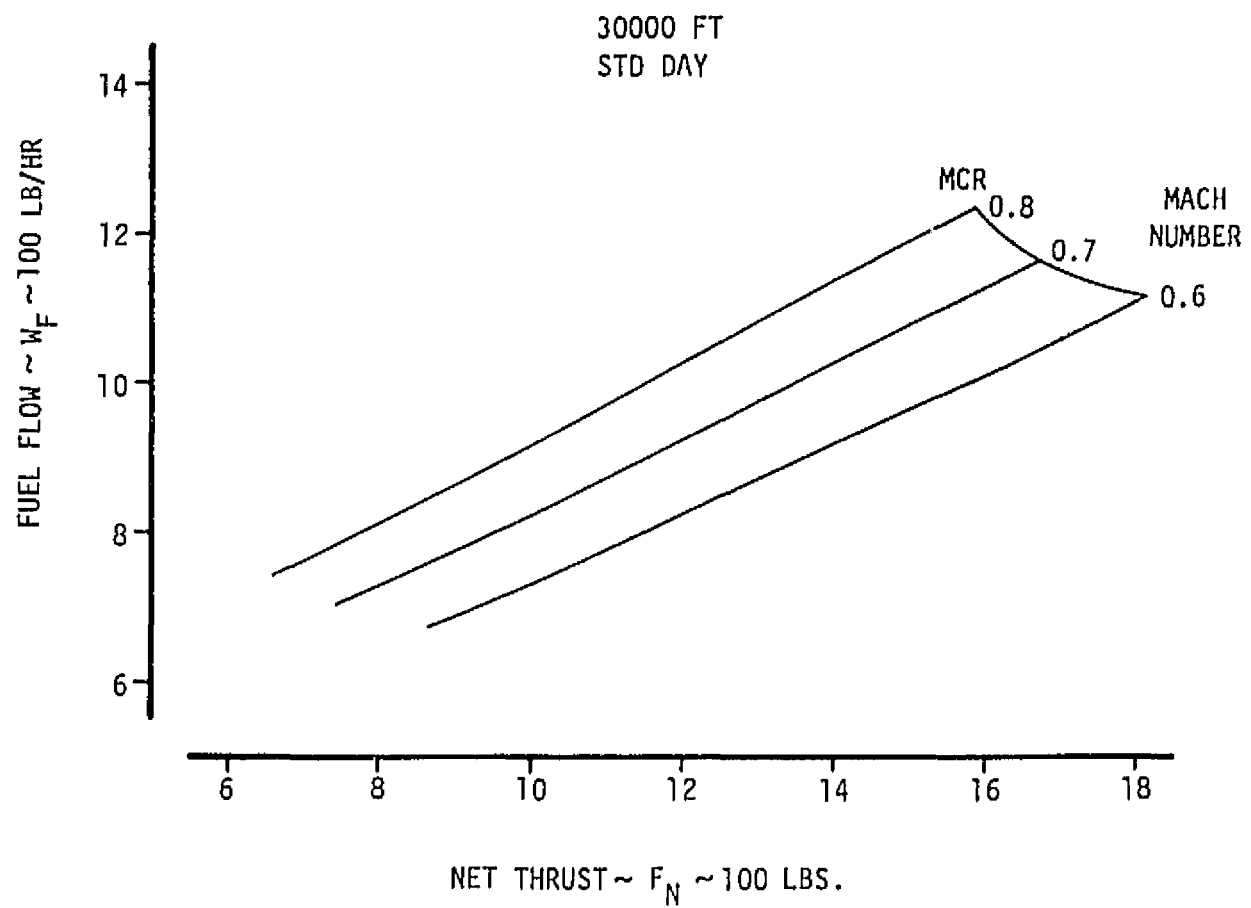

Figure B-29.—Allison PD370-16 Installed Cruise Performance 30,000 ft

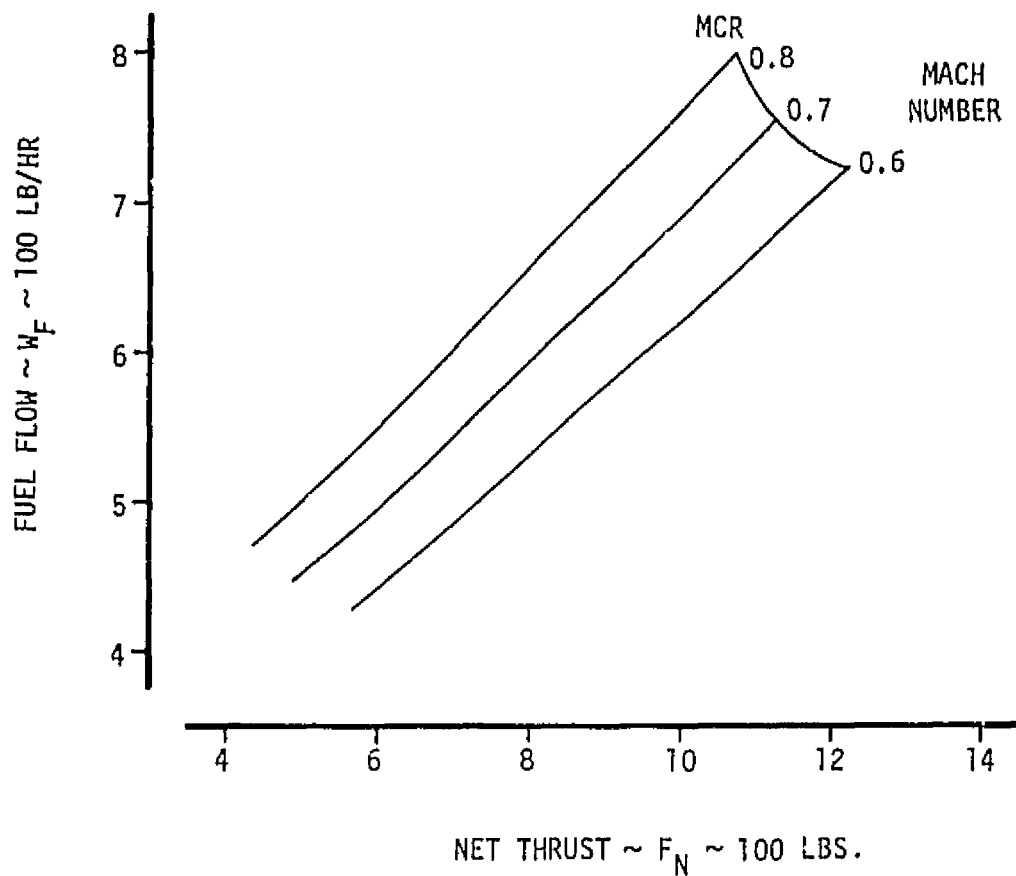

Figure B-30.—Allison PD370-16 Installed Cruise Performance 40,000 ft

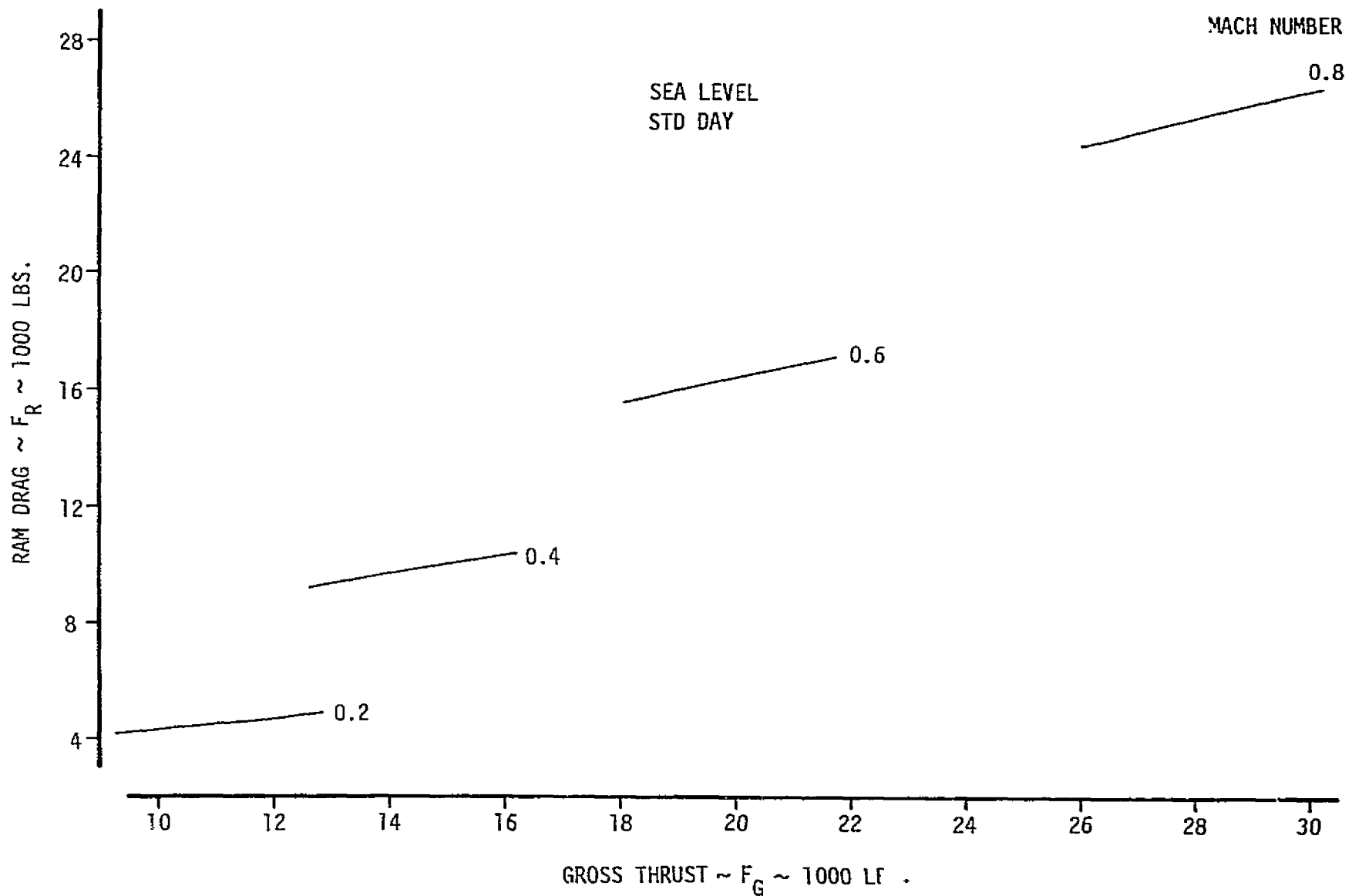

Figure B-31.-Allison PD370-16 Installed Cruise Performance Sea Level

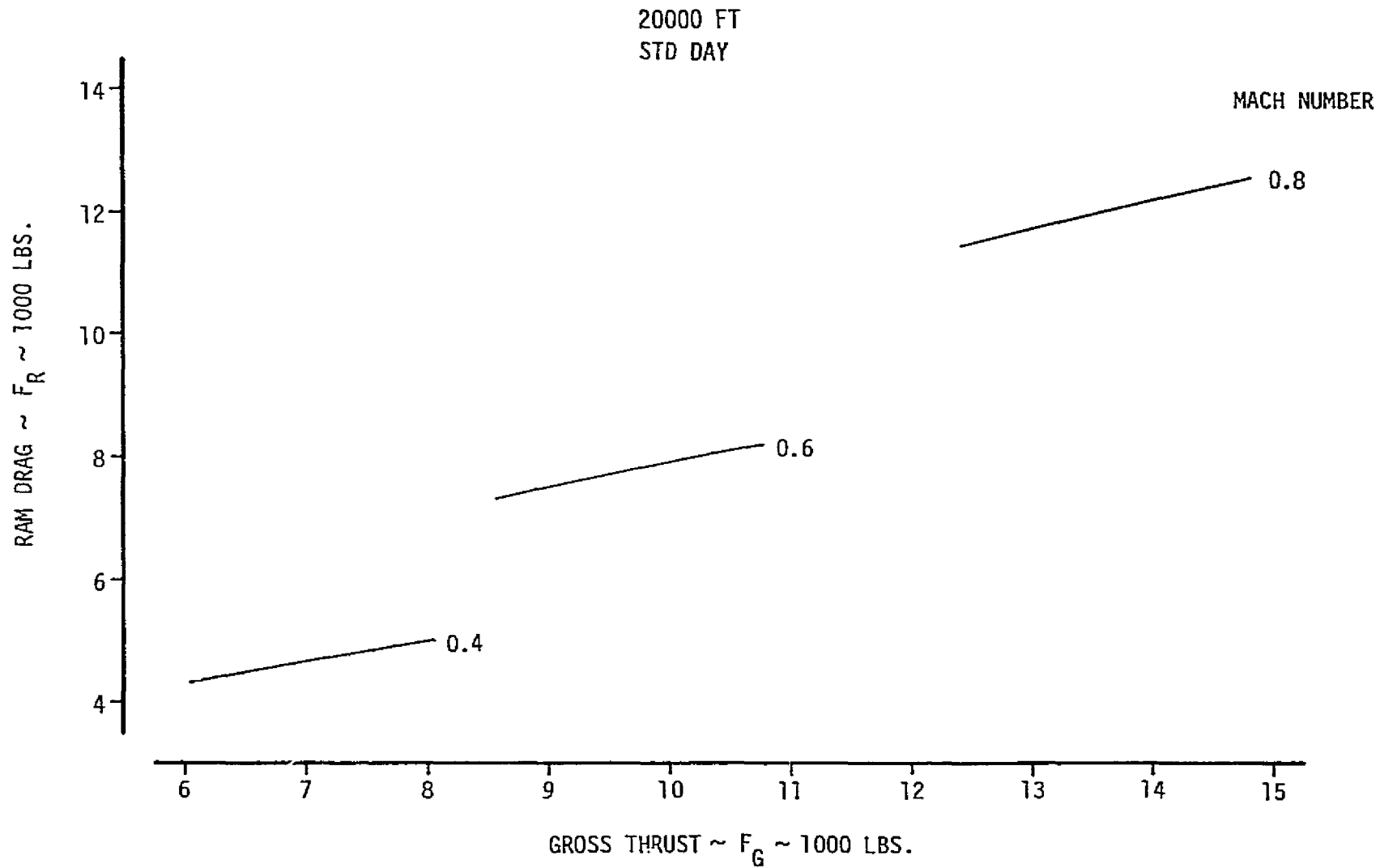

Figure B-32.—Allison PD370-16 Installed Cruise Performance 10,000 ft



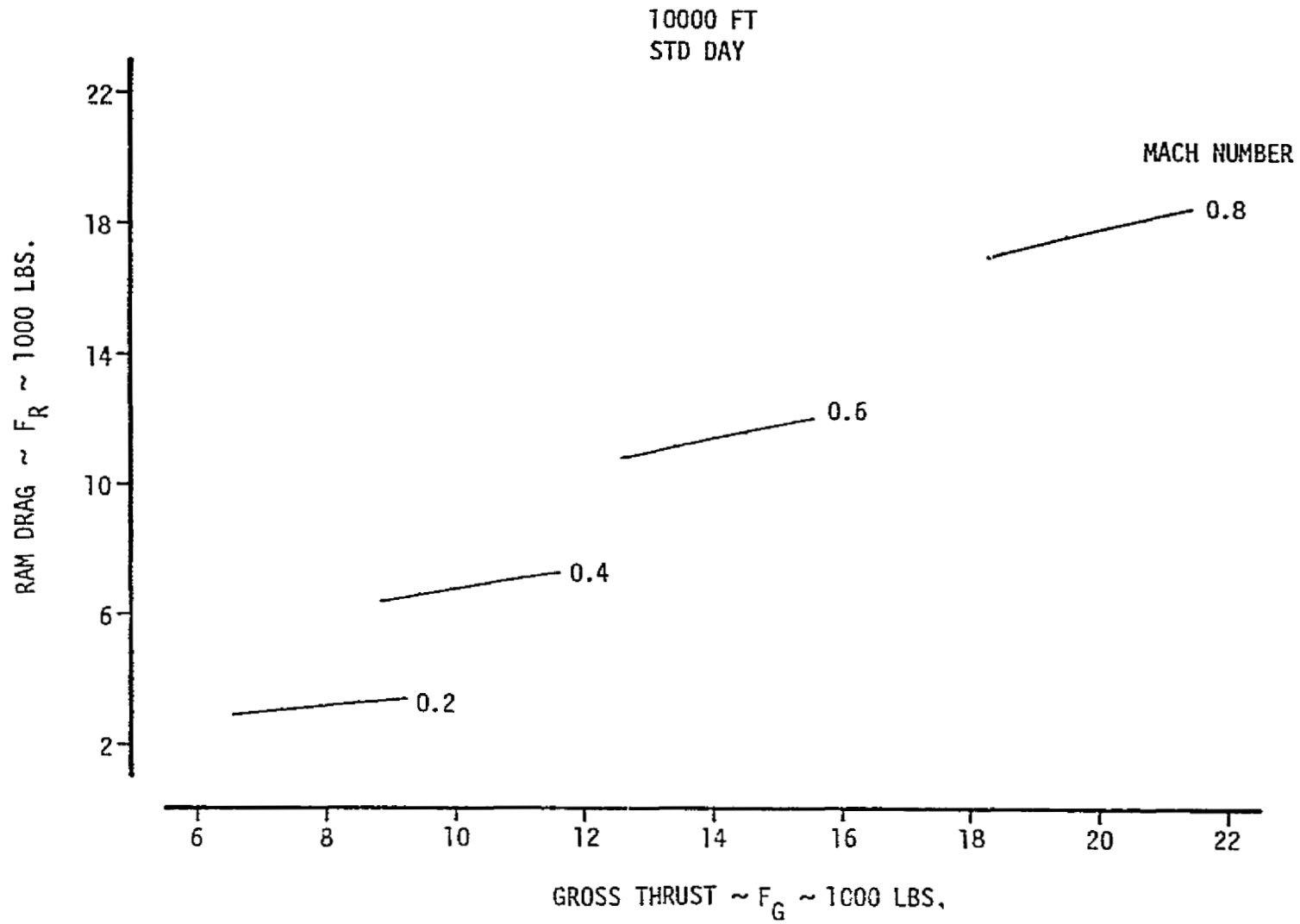

Figure B-33.—Allison PD370-16 Installed Cruise Performance 20,000 ft

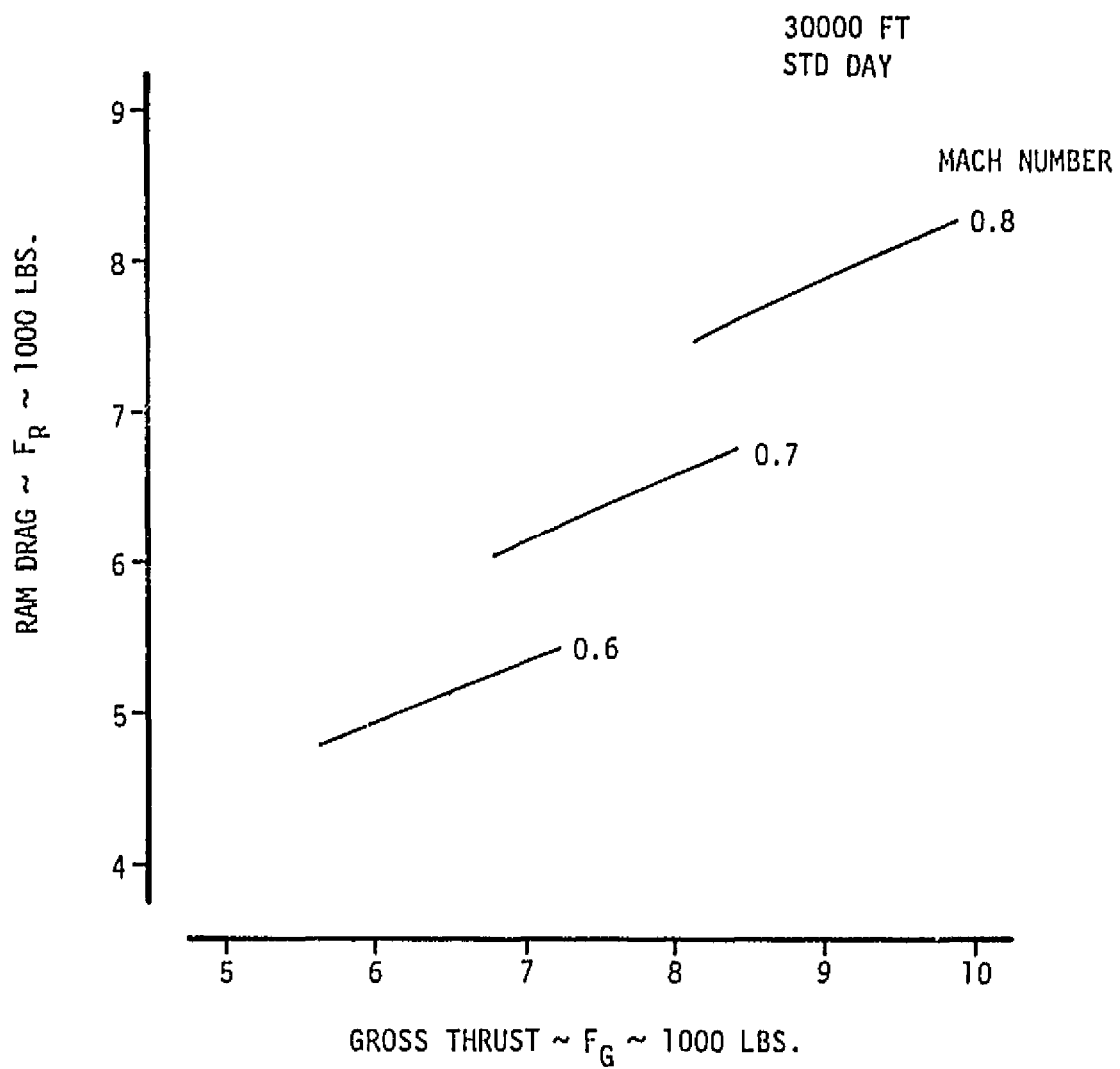

Figure B-34.—Allison PD370-16 Installed Cruise Performance 30,000 ft

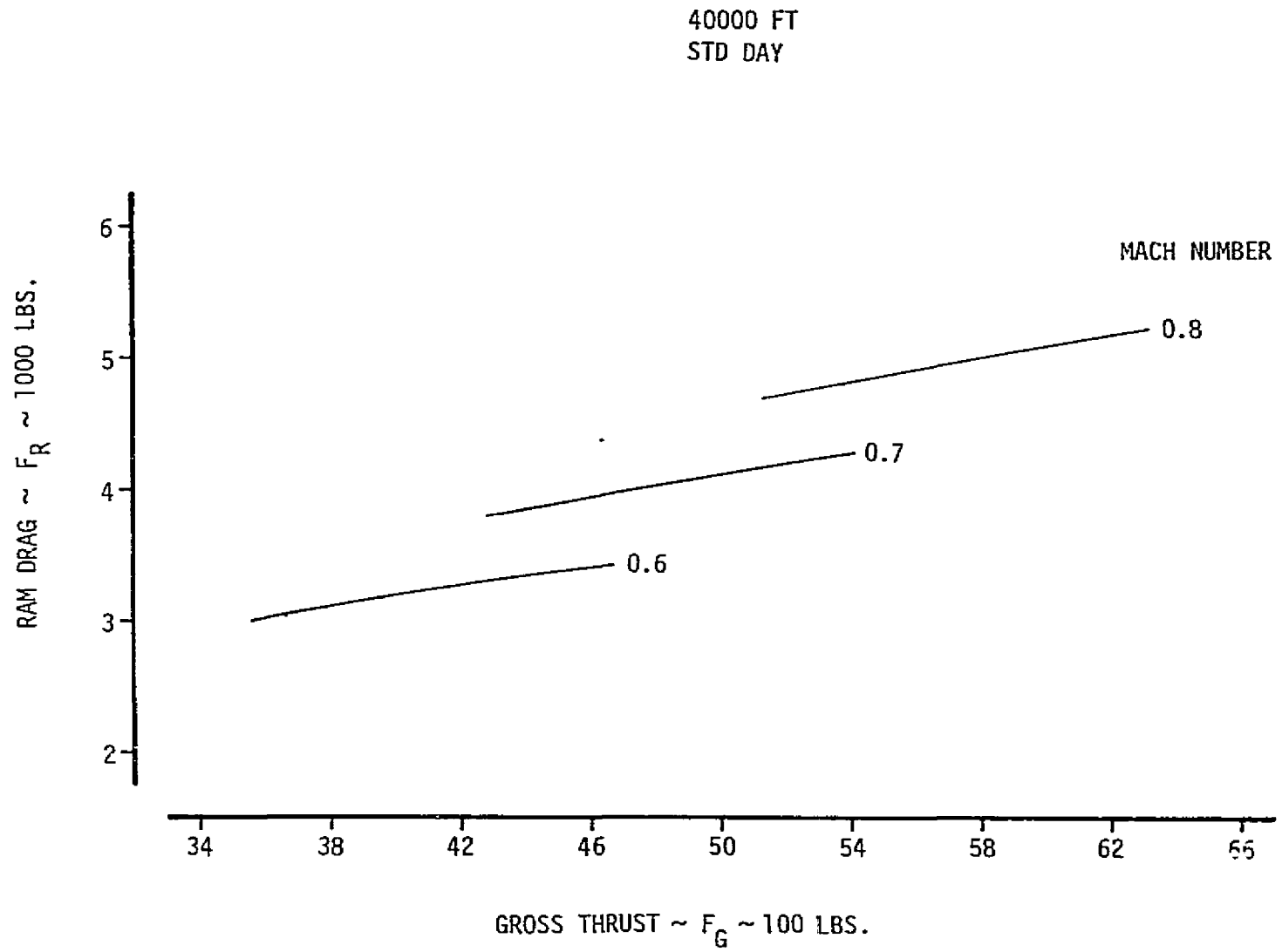

Figure B-35.—Allison PD370-16 Installed Cruise Performance 40,000 ft

## APPENDIX C - GROUND EFFECTS

This discussion of ground effects is qualitative and is based on reason and experience.

The ground effect phenomena of interest involves changes in the forces and moments on the airplane, and recirculation and reingestion of exhaust gas due to the presence of the ground.

The exhaust flow pattern is illustrated on Figure C-1. Considering the fan exhausts as flow sources, stagnation points and flow reinforcement lines (fountains) are shown in hover in figure C-2. The following discussion is based on this estimated flow pattern.

### Forces and Moments

The regions of positive and negative pressure can be estimated from the flow pattern. In Figure 7A-13 the density of the + and - signs indicates the pressure distribution for hovering. The incremental forces on the airplane by inspection appear to be positive (in the lift direction). This force increment is a function of the pressure distribution and the curvature of the surface. The pressure distribution is also a function of forward speed or wind velocity. The spanwise reinforcement line moves aft with speed causing the positive pressure concentration also to move aft. Again, by inspection, it appears that a nose down pitching moment will occur in ground effect. The magnitude of this moment change as the airplane enters and leaves ground effect must be determined experimentally, however, it is our opinion that this moment change will be gradual enough to be controlled by the proposed reaction (variable pitch) control system. Operating experience with the X-14, XV-5A, and the Harrier show that such moment and force increments can be controlled manually, without an extensive learning period. Use of an attitude hold mode on the automatic flight control system could further simplify the transition into and out of ground effect.

**PRECEDING PAGE BLANK NOT FILMED**

## Hot Gas Ingestion

Hot gas in this system occurs in the core of the lift/cruise fans. The hot core is surrounded by about ten times as much cool fan air. For ground operation the engine exhaust flow patterns for the Boeing 1041-133-1 configuration are indicated in Figure C-1. In the inboard section between the engines a fountain will probably result in fan and primary exhaust flows circulating underneath the fuselage and wing. The fuselage and low wing will act as a deflector which will minimize exhaust gas recirculation and inlet ingestion. Some mixing of hot primary exhaust and cool fan exhaust will occur. Due to the large mass of cool fan air surrounding and mixing with the hot primary core a low mean temperature of the mixed stream will occur which will reduce the risk of hot gas ingestion.

Exhaust gases flowing outward and away from the engine can be deflected by wind at some distance away and blown back into the inlet. Past experience with V/STOL Systems have shown that inlet ingestion of hot air can result in loss of thrust and hot streaks may lead to compressor stall. Factors influencing ingestion include exhaust temperature level, inlet location and engine arrangement, direction and strength of the wind and tolerance of the engine to ingestion effects. Much more work is required to predict the ingestion characteristics of the Boeing 1041-133-1 configuration with crosswind. Although no ingestion analysis has been conducted at this time, the takeoff and crosswind ingestion flight test experience of the VAK 191B and VJ101C (Ref. 1) V/STOL airplanes has been examined. Problems of reingestion and recirculation were solved by developing operational techniques considering engine speed, nozzle angle, forward speed and wind direction. These turbojet powered aircraft have hot exhausts and all mixing must occur with ambient air. It is our opinion that similar techniques can readily be developed for the high bypass ratio 1041-133-1 aircraft.

Ref. 1 - V/STOL Propulsion Systems September 17-21, 1973,  
AGARD CPD-135.

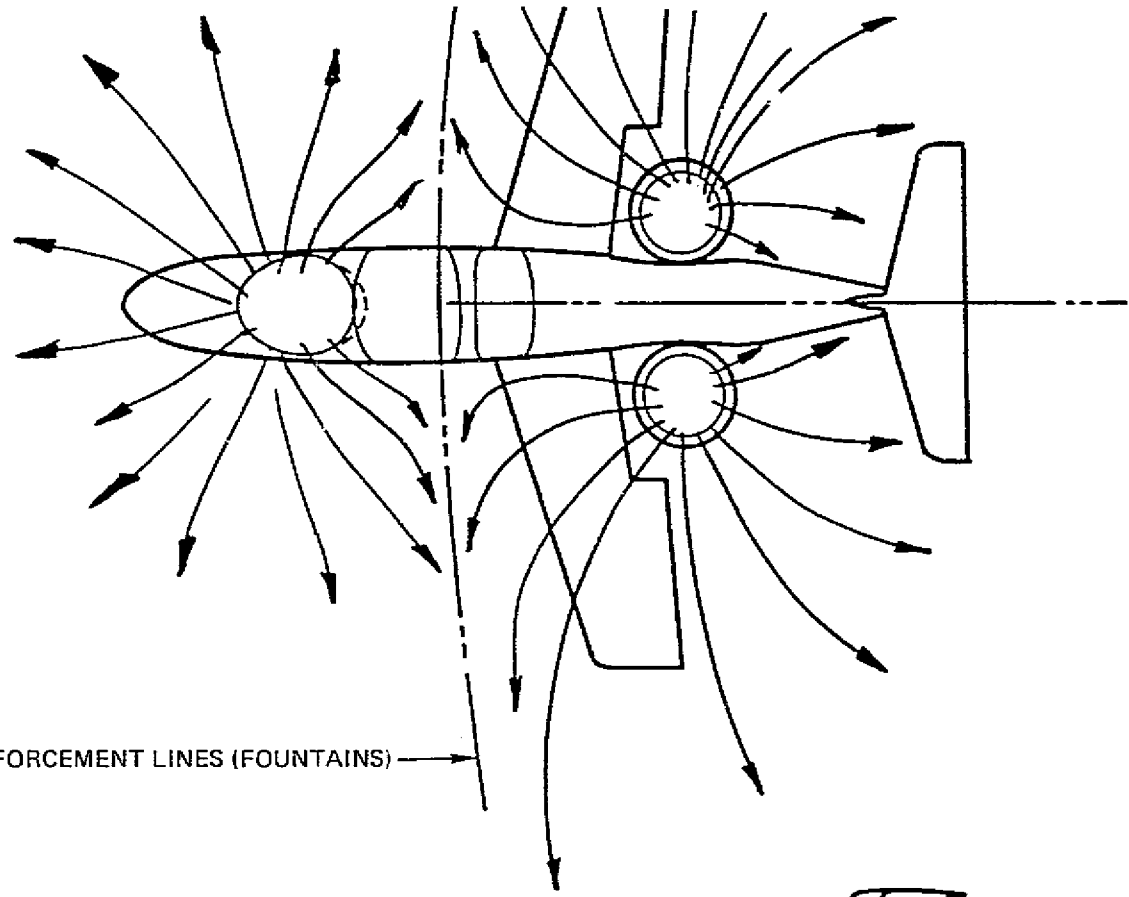

REINFORCEMENT LINES (FOUNTAINS)

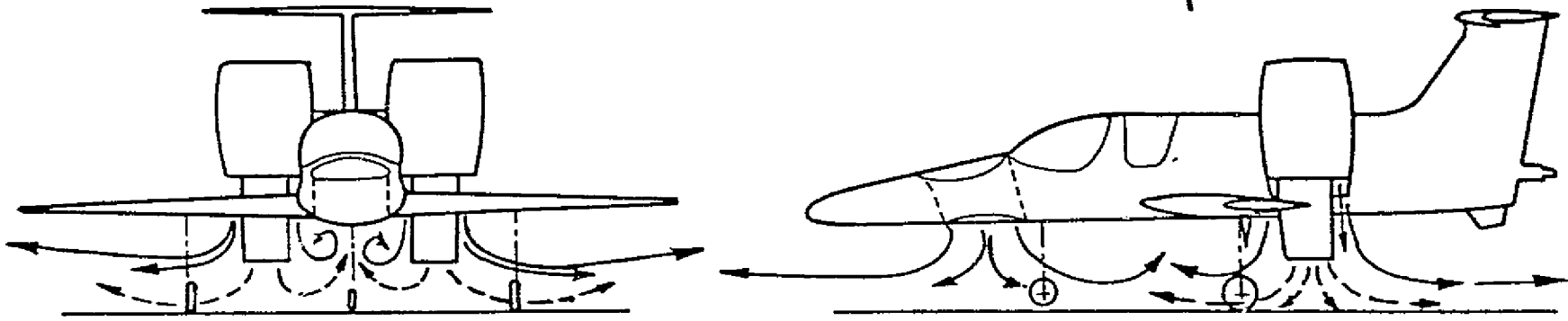

Figure C-1.-

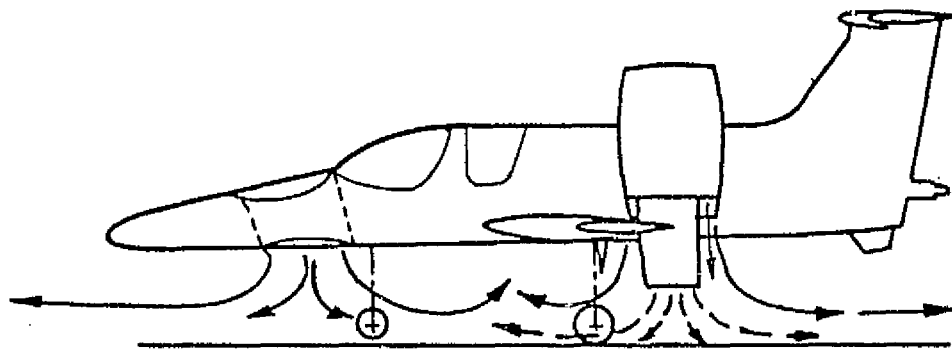
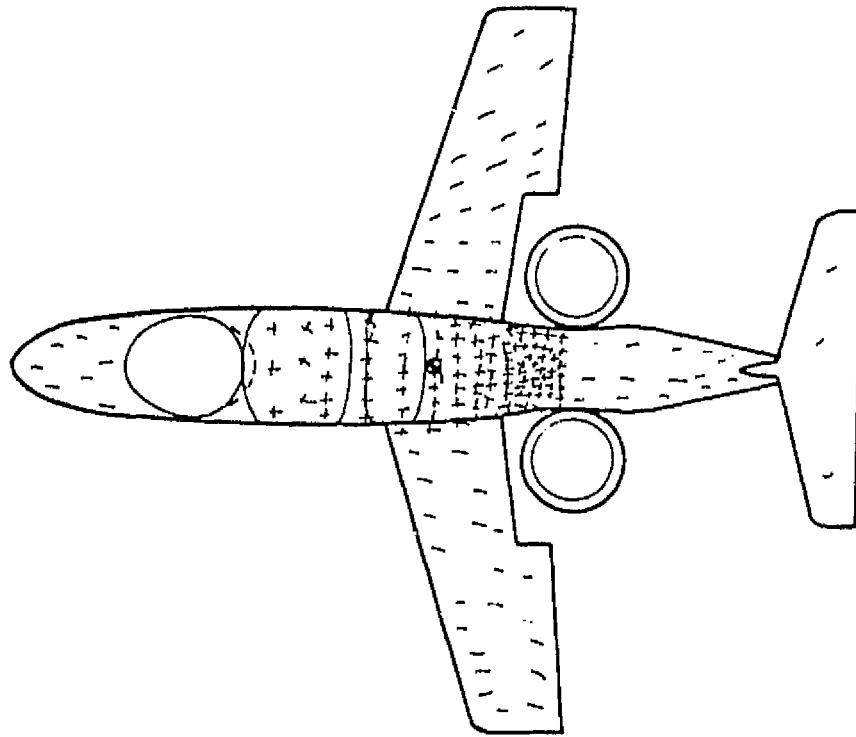

Figure C-2.-

## APPENDIX D - LIFT/CRUISE INLET AERODYNAMICS

Inlet operating requirements for these V/STOL airplanes are presented, available inlet data are reviewed, and the performance of the selected inlet is presented. A V/STOL airplane with tilting lift-cruise nacelles puts the inlets into very high local angle-of-attack conditions during transitions, particularly during the landing maneuver. Figure D-1 shows the nacelle angle (relative to body axis) and thrust requirements vs. airspeed for typical takeoff and landing transitions. It is seen that the inlet is required to operate at angles near  $90^{\circ}$  combined with speeds up to 100 knots. Conventional fixed-lip inlets with contraction ratios up to 1.65 would possibly prevent separation and excessive distortion, but insufficient data are available for such inlets. However, Boeing in-house data are available for a blow-in-door inlet shown on Figures D-2 and D-3. This inlet produces acceptable distortion at critical takeoff and landing transition points as shown on Table D-1.

### Inlet Operating Envelope

The lift-cruise engine inlet operating envelope for transition flight is derived from Figure D-1 by converting thrust requirements, including control thrust increments, to airflow requirements. For comparison with isolated inlet data the angle of attack and downwash are added to the nacelle angle  $\lambda$ , and the local airspeed is increased.

The nose fan inlet airflow requirements at low speed are the same as those of the lift-cruise fans, except during a STOL takeoff, where the nose fan operates at part power. The nose inlet is designed for low speed operation and will turn the flow such that the relative inflow angle into the nose fan is independent of angle-of-attack.

The maximum corrected airflow at the fan face of  $41.7 \frac{\text{LB}}{\text{sec-ft}^2}$  occurs in V/STOL takeoff and climb. This results in a fan face mach number of  $M_2 = .60$ . The inlet throat is currently sized for this condition.



A number of critical operating conditions were selected from the operating envelope shown on Figure D-1. Control requirements were added or subtracted to obtain critical inlet design conditions. These are shown on Table D-1.

### Distortion Criteria

No distortion limits are available for the fan. The fan is expected to be able to operate even in complete stall. However, a fan thrust loss will occur in a separated inlet. Therefore, inlet flow separation cannot be tolerated in those areas of the flight envelope where thrust, including thrust requirements for control, is critical.

Distortion criteria for the Allison T701 core engine were obtained from reference 1. Individual engines have characteristic distortion limits and as the engine is developed the distortion tolerance will be established. Until then, we will use reference 1 limits as shown on Figure D-4. At a critical condition where no loss of thrust is allowable such as the final phase of an engine-out emergency landing, the "no power loss" curve applies, at all other conditions the "stall free limit" curve applies. These criteria must be met at the core inlet, downstream of the fan. Any distortion applied to the fan will be propagated through the fan and may be attenuated or amplified. Due to lack of data it will be assumed that the distortion is not modified by the fan.

Distortion parameters used on Figure D-4,  $K(\theta)$  and  $K(R)$ , are weighted indices in the form of  $\frac{\Delta PT}{P_{T2}}$ . Table D-11 shows the conversion of these limits into the form of  $\frac{\Delta PT}{q_2}$ . It is seen that when full thrust is required such as the final phase of an emergency vertical landing, local pressure losses due to distortion cannot exceed .28 of the local  $q$ , whereas at lower airflows local losses in the inlet must exceed several (one-dimensional)  $q$ 's to produce  $\frac{\Delta PT}{P_T} = .15$  distortion. This implies that inlet separation may be tolerable at lower airflows.

Thus, for the time being, the core distortion limit at the maximum airflow, if no thrust loss may be tolerated, is  $(K_R)^2 + (K_\theta)^2 = .057^2$ . At all other conditions, it will be interpreted as  $(K_R)^2 + (K_q)^2 = .15^2$ . The core engine will be considered to be subject to distortion within 25% of the fan airflow next to the hub region. This provides for a generous allowance for crossflows, since the bypass ratio is in the order of 10. A fan flow distortion limit of

$\frac{\Delta p_T}{p_T} = .1$  is reasonable for no-thrust-loss conditions, and no limit for other conditions.

#### Fixed-Lip Inlets in Crossflow

High distortion levels occur when the internal flow separates and when the internal Mach number is high. Separation is generally a function of the ratio of crossflow velocity to internal velocity, contraction ratio  $\frac{A_{throat}}{A_{highlight}}$ , and inlet lip shape.

Much research has been done to define the onset of separation in terms of velocity ratio, contraction ratio and lip shape. Unfortunately, little or no distortion information is given and often the internal Mach number is low or not given, such that the data are not useable for critical takeoff and vertical landing conditions when maximum airflows occur. For approach conditions, when thrust requirements are low, separation may be tolerable at the lower airflows, when it does not produce excessive distortion, so data in terms of separation limits only, are too conservative.

Distortion data at high inlet airflows are available from YC-14 inlet development tests (Ref. 2) up to a contraction ratio of 1.34 and from a Boeing NASA study on low-speed and angle-of-attack effects on sonic and near-sonic inlets (Ref. 3) up to contraction ratios of 1.45. At high airflows, the 1.34 contraction YC-14 inlet separates at  $\alpha + 50^\circ$ ,  $V_o = 67$  knots, and at  $\alpha = 90^\circ$ ,  $V_o = 36$  knots. The 1.45 contraction ratio inlets show excessive distortion for critical condition 2 of Table D-1. Inlets up to 1.56 contraction ratio tested by NASA (Ref. 4) show attached flow up to  $70^\circ$  at high airflows, but no data are given for distortion at higher angles and lower airflows. It is estimated that an inlet having a contraction ratio in the order of 1.65 might be acceptable, but further testing and study is required.

#### Blow-in-Door Inlet

Boeing test data are available for a blow-in-door inlet for V/STOL applications shown on Figures D-2 and D-3. This inlet was tested at speeds up to 150

knots, crossflow angles of 0, 40°, 60° and 90° and corrected airflows from 34 to 42.5 lb/sec-ft<sup>2</sup> at the fan face. Distortion at lower airflows is not expected to increase in terms of  $\frac{\Delta p_T}{p_T}$ . Total pressure data from a rotating cruciform rake and some static pressure data are available in Ref. 5 for this and several fixed-lip designs of moderate contraction ratios.

Figure D-5 shows a typical isobar plot at 90°, 100 knots crosswind. The data were obtained from a cruciform rake rotated in 10 degree intervals. It is seen that there is considerable inlet distortion, most of it near the windward lip and behind struts. From the data distortion plots were generated. Figure D-6 shows the fan face distortion data. Fan inlet distortion in terms of  $\frac{PT \text{ MIN} - P_T \text{ AVG}}{P_T \text{ AVG}}$  is shown for six critical operating points on Table D-1.

Of greater importance is the distortion tolerance of the T701 engine. The engine airflow passes through the hub region of the fan. The inner 25% of the fan flow was assumed to include all of the engine airflow, with an allowance of 2.5 factors for possible crossflows between the fan inlet and engine inlet. The distortion within the inner 25% is shown on Figure D-7. The limit for the T701 engine is also shown. Data from this plot was used to estimate distortion for 6 critical flight conditions. The results are shown on Table D-1. The expected distortion is close to the limits. Admittedly, the fan may amplify the distortion. ON the other hand, the inlet model tested was designed for a high critical Mach number and had a contraction ratio of 1.08 at the lip and 1.18 at the internal lip when the doors are open. These values could be increased considerably for an aircraft whose cruise Mach number is .75, resulting in lower distortion.

#### Inlet 'Fixes'

As previously noted, the performance of the blow-in-door inlet can probably be improved by increasing the contraction ratio at both primary and secondary inlet lips.

Should distortion levels at the engine inlet prove excessive, it is possible to design a flow diverter such that the engine is fed air from the 270° high pressure region of the total annulus, where the distortion is greatly reduced. The isobars on Figure D-5 show that the distortion admitted would not exceed 2%.

Inlet recovery of the blow-in-door inlet as tested is shown on Figure D-11. Cruise recovery should be near that shown for 150 knots, zero nacelle angle,

$$\frac{P_{T2}}{P_{T0}} = .998.$$

The blow-in-door (vane) inlet as reported in Reference 5 was tested as a small scale model. It was found to have acceptable performance (including distortion). When this tested inlet is scaled up to full size for a 62 inch diameter fan, the length becomes 54 inches which is much longer than desired. A review of this inlet indicates that by leaving the forward variable part of the inlet as was tested, the rearward portion can be shortened about 22 inches. This is accomplished by increasing the downstream dilute diameter, making the second throat diameter equal to the fan face diameter, keeping the second contraction ratio at 1.3, and eliminating the diffuser ahead of the fan face. The new inlet geometry is shown in Figure D-8 with the geometry of the tested model superimposed.

#### Effect of the Airplane on the Inlet Flow Field

A potential flow analysis of the wing-body was performed to determine its effect on the flow field at the inlet, since all available inlet data is for isolated inlets.

The wing-body was represented by the network shown on Figures D-9 and D-10. The incompressible, potential flow around this network was solved at angles-of-attack of 0, 5, 10, 15 and 20 degrees. No inlets or inlet flow were represented, but the influence of the wing-body on the flow field in the inlet plane was calculated. Results are shown on Table D-3 in terms of magnitude

of downwash and sidewash velocity, relative to the freestream, for five points in the inlet plane. It is seen that the downwash is in the favorable direction and increases with angle-of-attack, such that the net increase in inflow angle is only 20% to 33% of the angle-of-attack. Local velocities are generally increased. For instance at  $\alpha = 10^\circ$ , with the inlet deflected  $90^\circ$ , the velocity ratio  $\frac{V_{\text{local}}}{V_{\text{freestream}}}$  at the inlet centerline is 1.045, leading edge 1.067 and trailing edge 1.023. These results were obtained at zero flap deflection. It is expected that the effect of flaps will be similar to the effect of angle-of-attack at equal lift coefficients.

In summary, the flow field effects are not expected to be significant. Since angle-of-attack has already been taken into account on Table D-1, the downwash is a beneficial effect while the local velocity is a detrimental effect. Their effects tend to cancel.

#### Estimated Inlet Recovery and Drag

Inlet recovery of the blow-in-door inlet as tested is shown on Figure D-11. Cruise recovery should be near that shown for 150 knots, zero nacelle angle,  $\frac{P_{T2}}{P_{T0}} = .998$ . Cruise inlet drag tests were conducted on fixed-door models at

several door positions. Figure D-12 shows that the lowest spillage drag at cruise mass flows, which are high for this engine, occurs when the doors are kept closed or the gap is small allowing essentially only the boundary layer to bypass. The drag includes skin friction and the variation with mass flow is very flat over the region of interest. Analysis has shown that skin friction contribute  $\Delta C_D = .02$ . Thus, spillage drag in this range of mass flows is negligible if the inlet doors are closed or nearly closed.

#### Model Scale Effect

In comparing model data with full scale inlet data, the non-simulation of Reynolds number due to difference in scale is a consideration. The low Reynolds number of the smaller inlet results in more adverse boundary layer separation conditions, because of the larger buildup of laminar boundary layer downstream of the stagnation point and the relatively thicker turbulent boundary layers

with higher shape factors. If the conditions on the model are not severe enough to separate the boundary layers, small scale and full scale flow results agree quite well. Some test results show that separation on a small model is not experienced at full scale.

The full scale 1041-133 inlet performance is expected to be the same or better than the small scale inlet model. The estimated inlet performance is based on small scale model tests, therefore, this performance is expected to be conservative.

## REFERENCES

- 1) Allison T701 Specification, "Military Turboshaft Engine - Prime Item Development Specification 844-B", January 1975.
- 2) Boeing Coordination Sheet YC-14-PROP-019, "Preliminary Results of YC-14 .01734 Scale Model Inlet Tests in 9'x9' WW Speed Tunnel," R. J. Ream, April 23, 1973.
- 3) NASA CR-134 778, D6-42392, "Low Speed and Angle-of-Attack Effects on Sonic and Near-Sonic Tests," T. E. Hickcox, R. L. Lawrence, J. Syberg and D. R. Wiley, March 1975.
- 4) AIAA Paper #75-64, "Internal Cowl-Separation at High Incidence Angles," A. K. Jakubowski and R. W. Luidens.
- 5) Boeing Document T6-3219, "Model Test of V/STOL Cruise-Lift Fan Inlet Performance," P. R. Stewart, May 4, 1964.
- 6) NASA-SP-116, Paper No. 8, "Summary of Large-Scale Tests of Ducted Fans," by K. W. Mort, April 4, 1966.
- 7) Proceeding of the 4th Congress of the Aeronautical Sciences, Paris, August 24-28, 1964, "Analytical and Experimental Studies of Normal Inlets, With Special Reference to Fan-In-Wing VTOL Power Plants," by U. W. Schaub, and E. P. Cockshutt.
- 8) Boeing Document D6-20628TN, "Test of a Model Fan in a Two Dimensional Wing at Forward Speed," by D. L. Baum, B. Neal, and J. M. Zabinsky December 1967
- 9) Society of Automotive Engineers Journal, September 1969, pg. 44-51, "3-D Potential Flow Method", by P. E. Rubbert and G. R. Saaris, 1969.

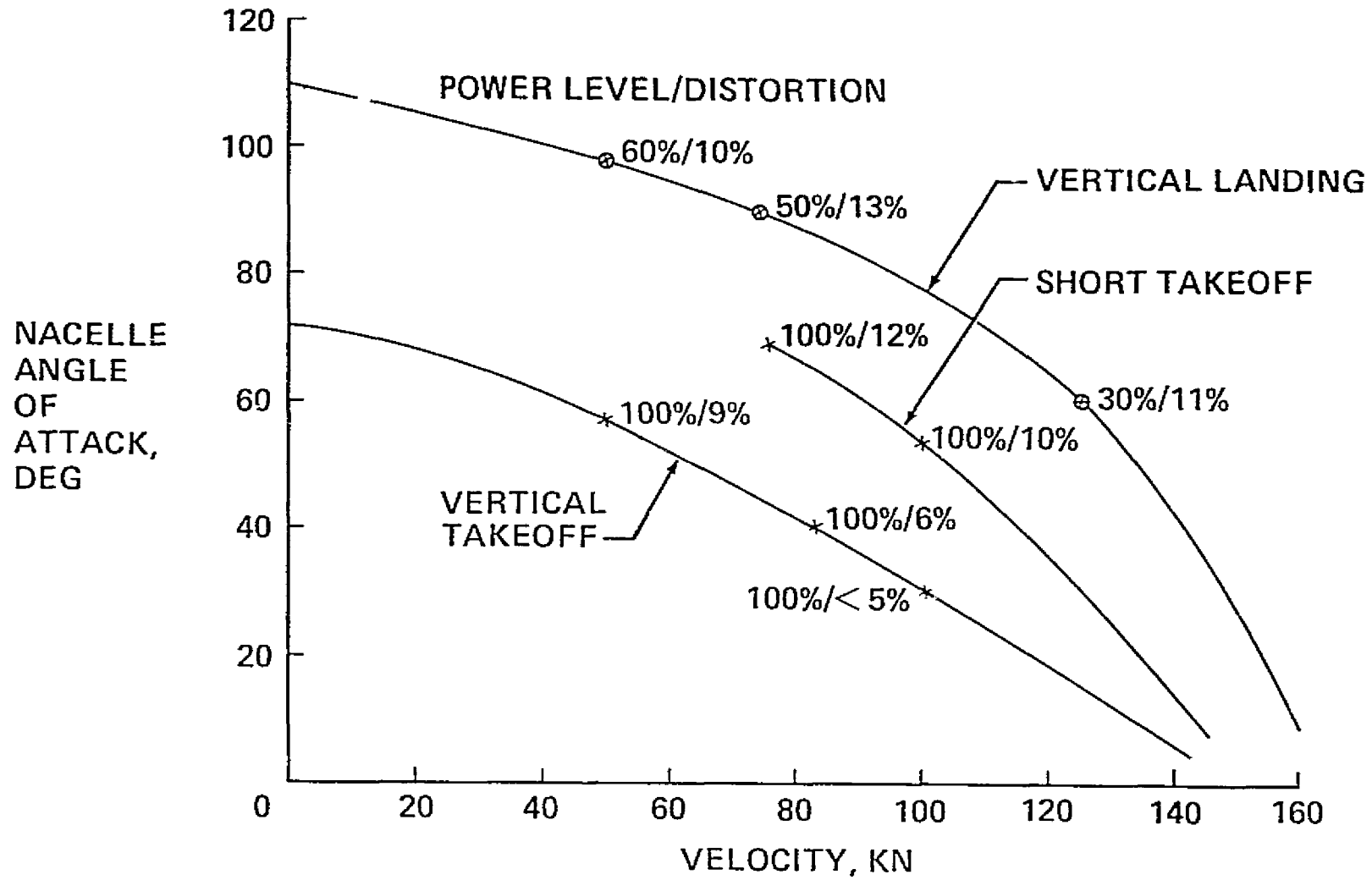
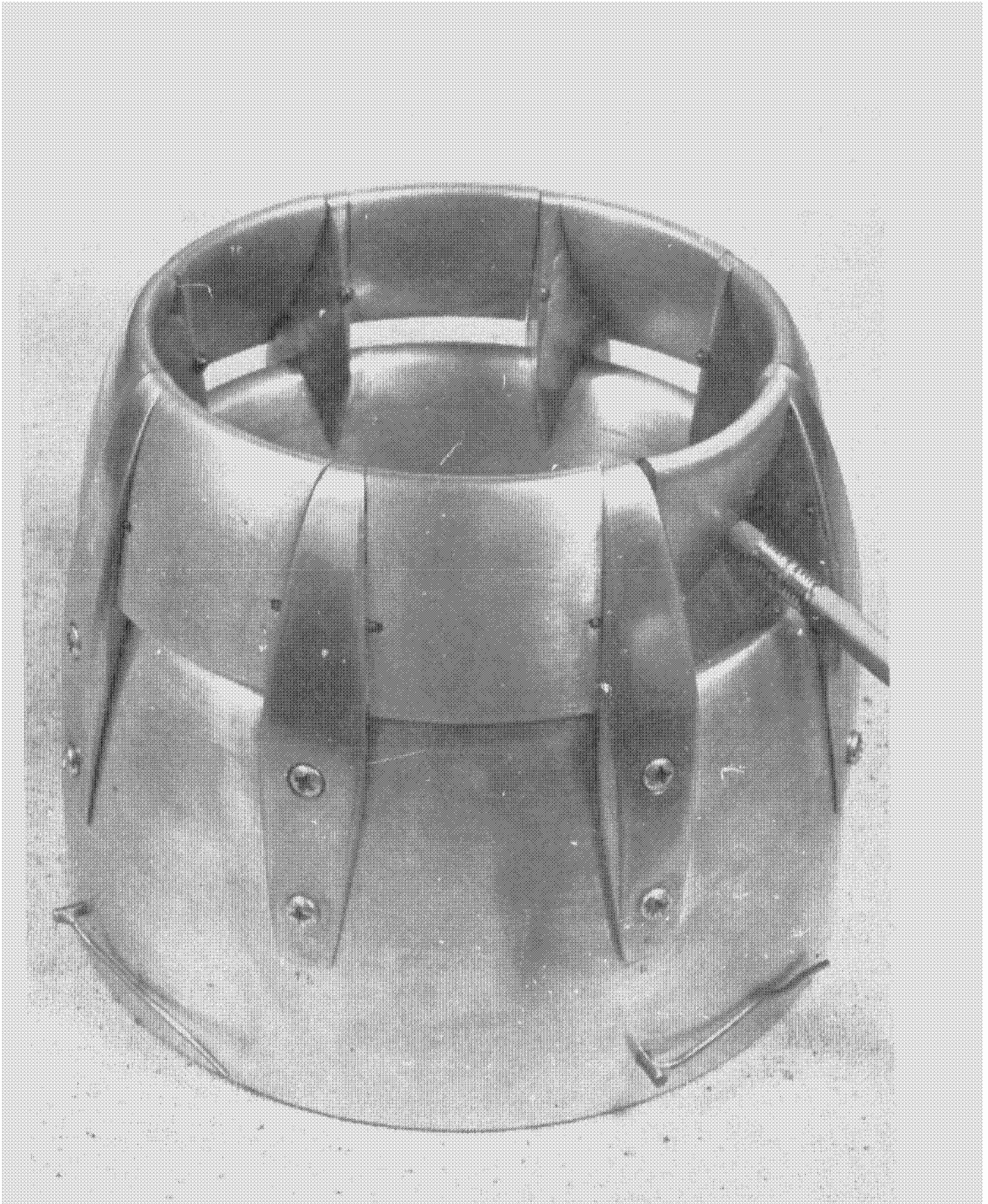

Figure D-1.-Nacelle Operating Envelope





*Figure D-2.-Blow-in-Door Inlet Model*

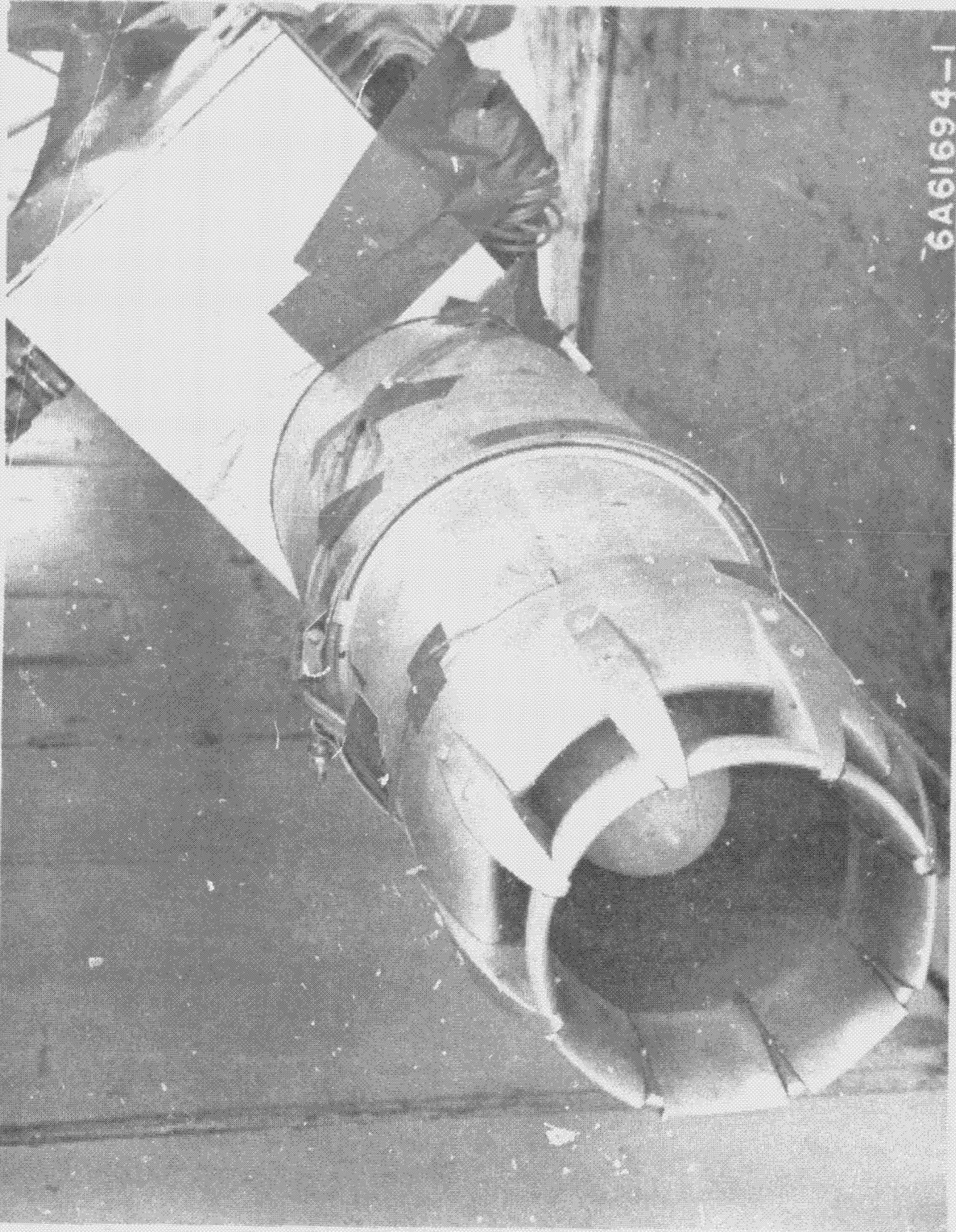

Figure D-3.- Blow-in-Door Inlet Model in Tunnel, Doors Open

ORIGINAL PAGE IS  
OF POOR QUALITY

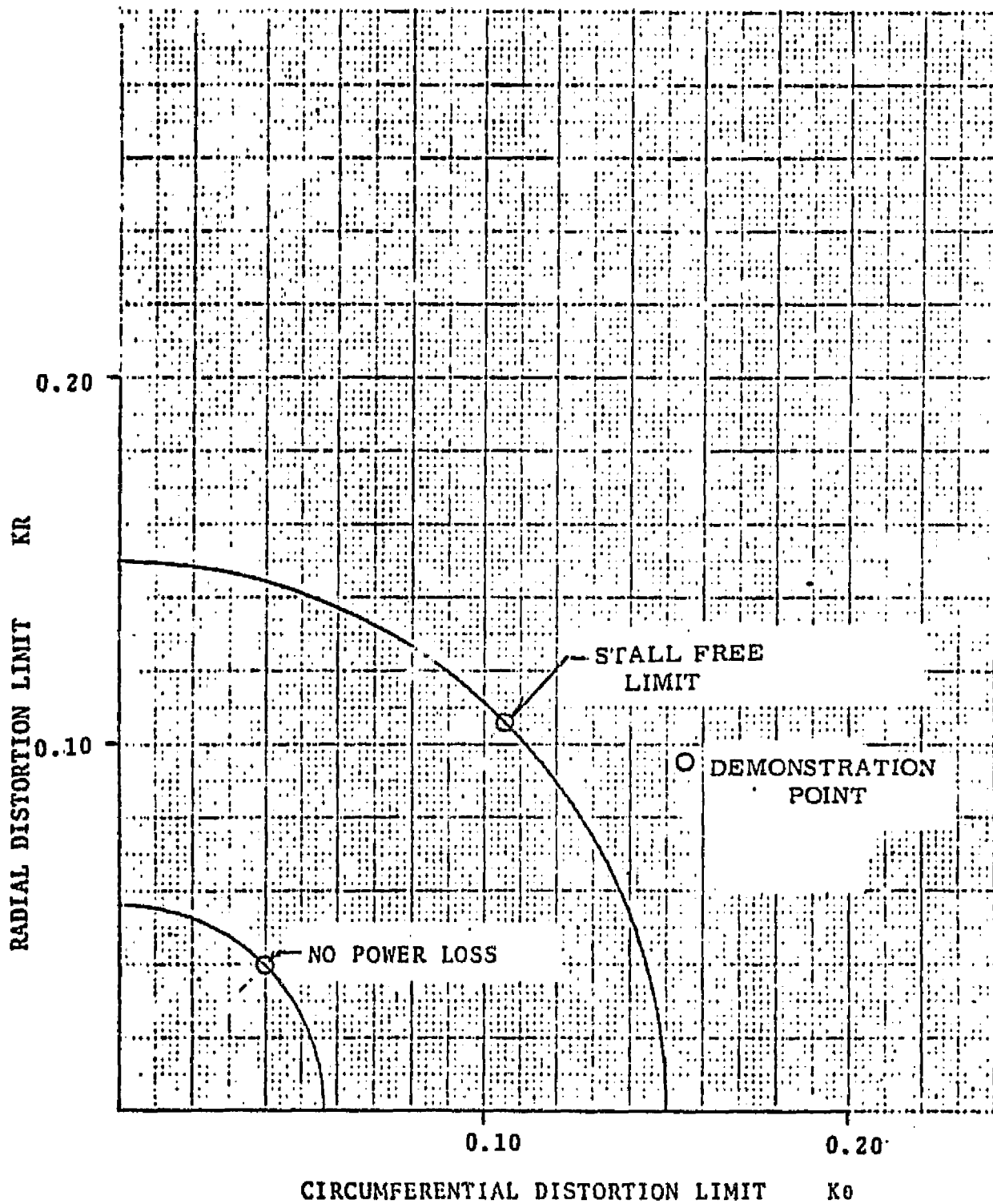

Figure D-4.-Inlet Air Pressure Variation Limits for Radial and Circumferential Total Pressure Distortion

$V_0 = 100$  KNOTS  
 $\alpha = 90^\circ$

INLET: VANE  
COND. NO. 3.6340

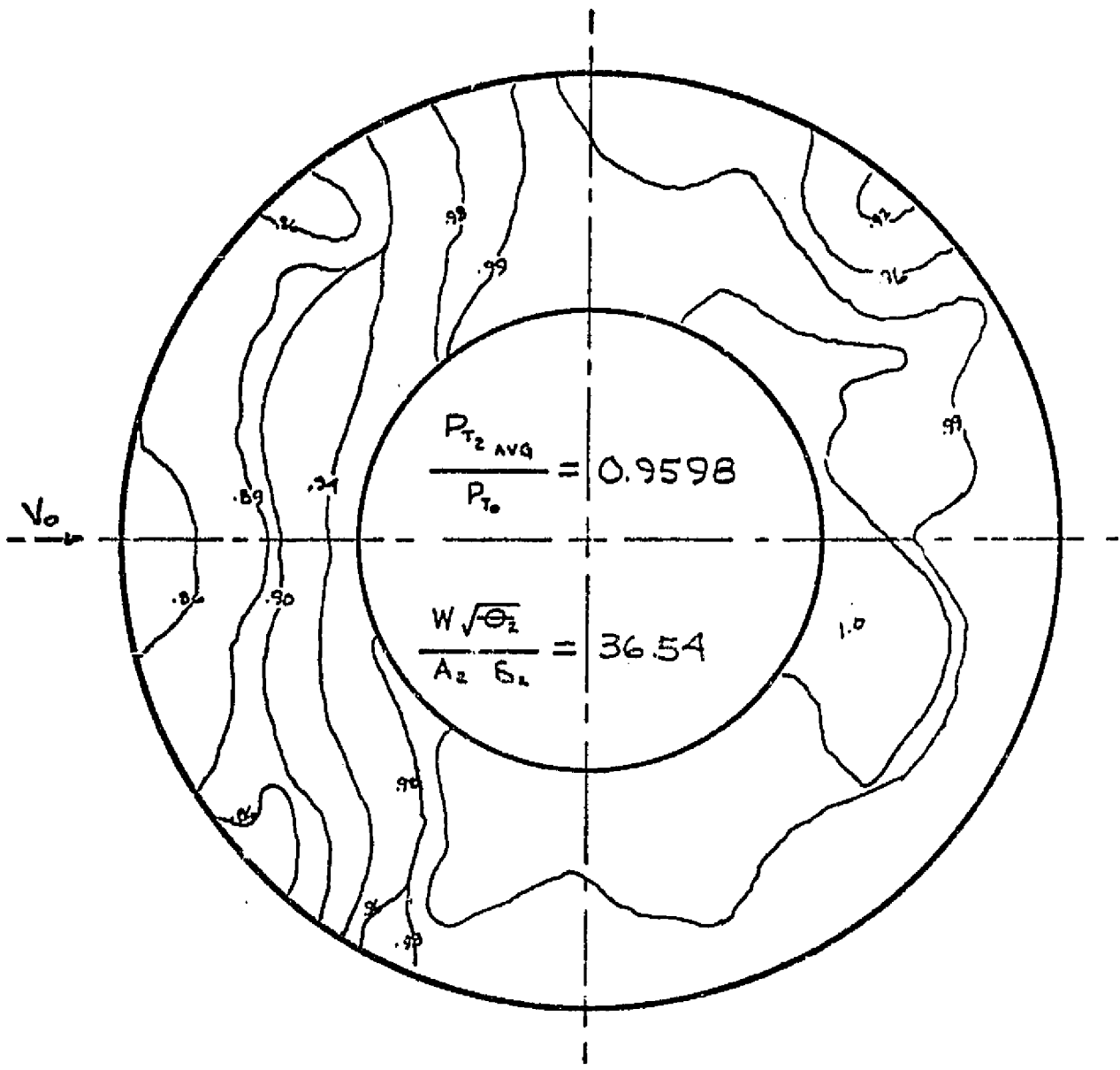
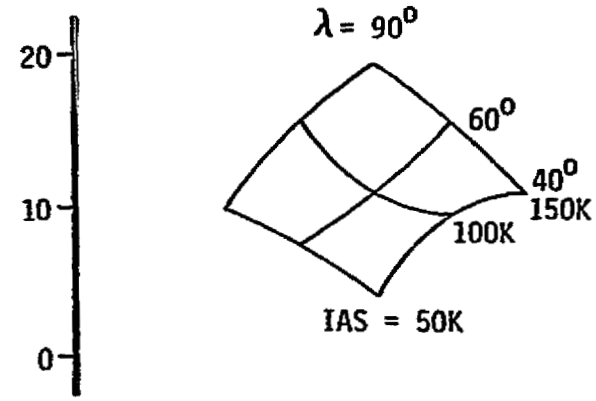
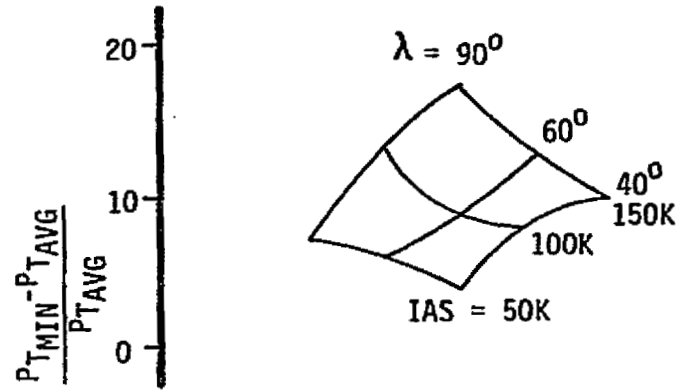

Figure D-5.-Isobar Plot

$$\text{CORRECTED AIRFLOW} = W \sqrt{\theta_{T_2}} / A_2 \delta_{T_2} = 34.0$$

$$= 37.5$$



$$= 41.0$$

$$= 42.5$$

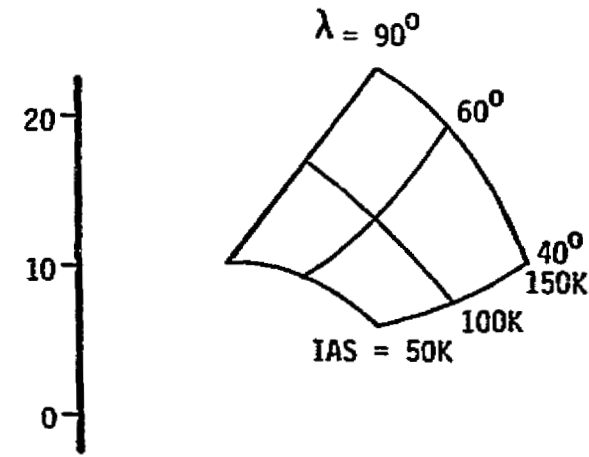
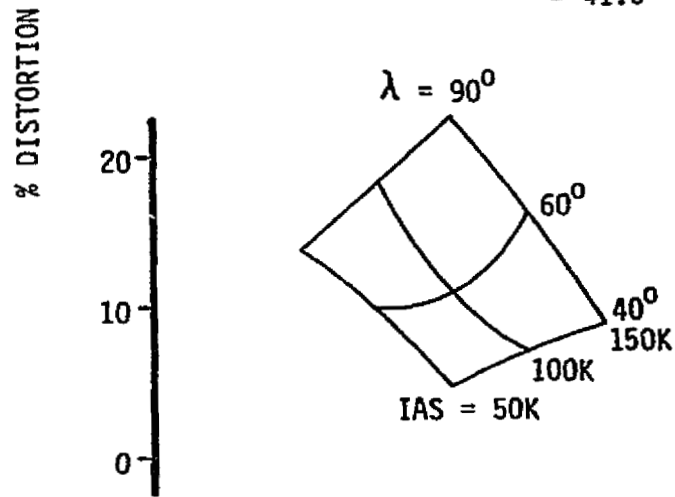
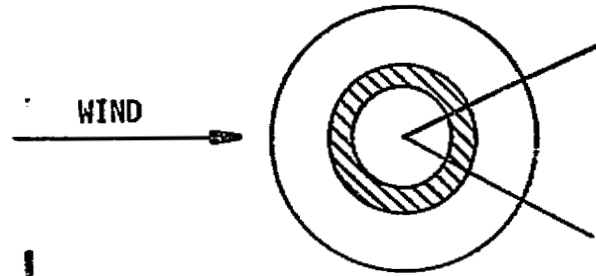

Figure D-6.—Blow-in-Door Inlet Distortion



$$\% \text{ DISTORTION} = \frac{P_{TMAX} - P_{TMIN}}{P_{TMAX}} \text{ OVERSHADED AREA}$$

SHADED AREA = 25% OF FAN A<sub>2</sub>

$$\ominus \frac{P_{TMAX} - P_{TAVG}}{P_{TMAX}} \text{ OVER } 60^\circ \text{ OF SHADED AREA ON LEE SIDE}$$

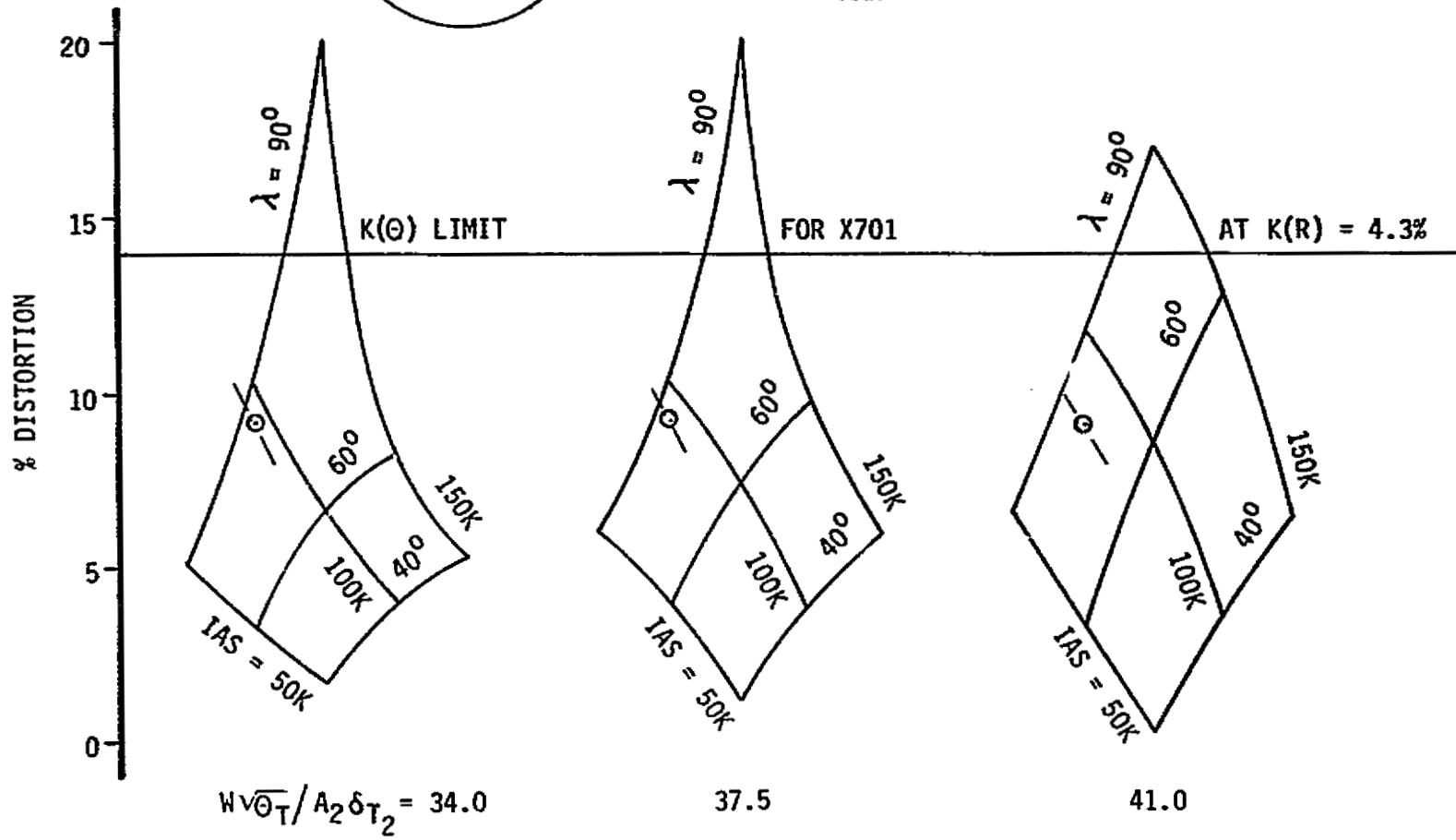

Figure D-7.-Blow-in-Door Inlet Pressure Distortion in Hub Region

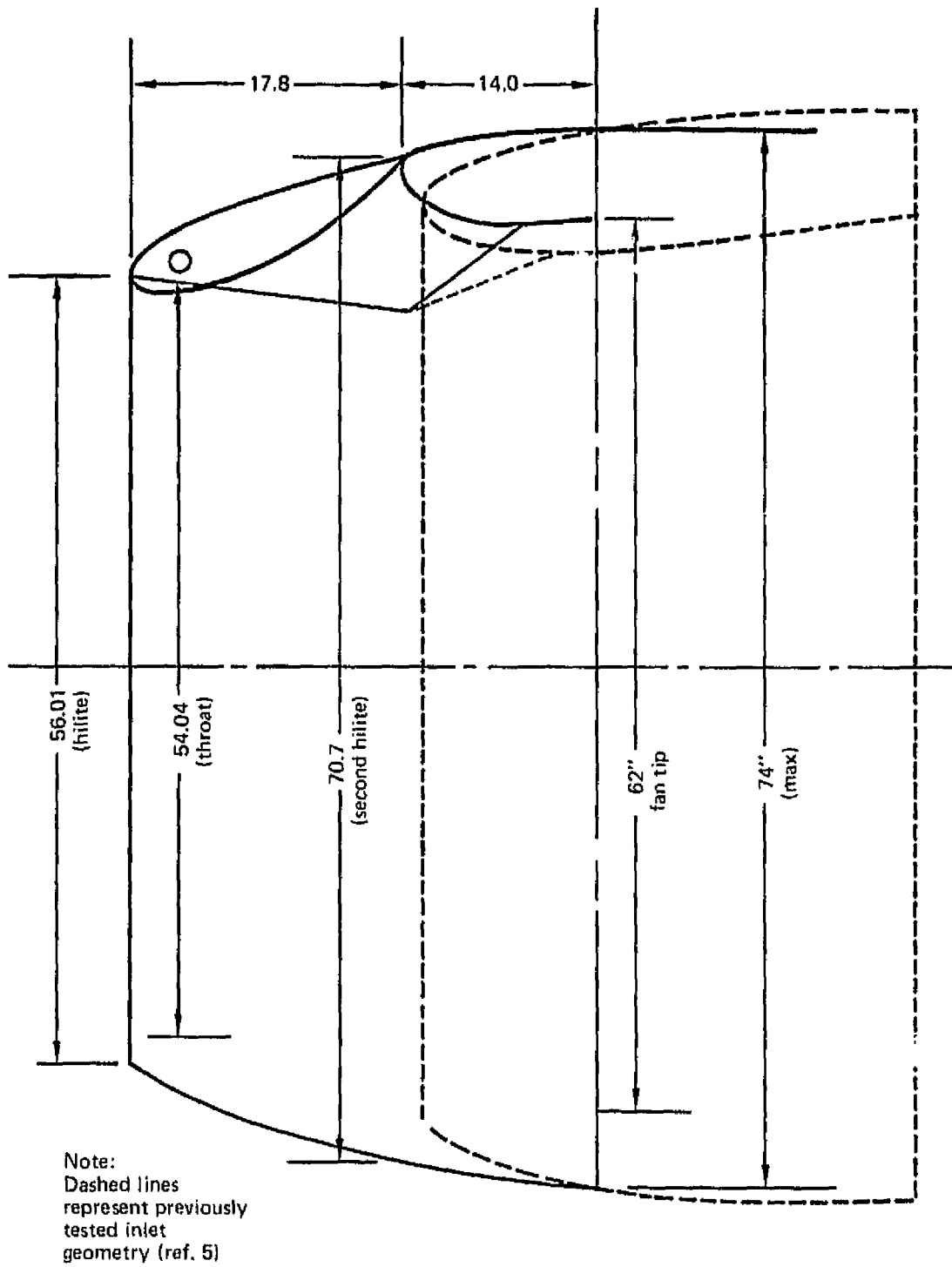
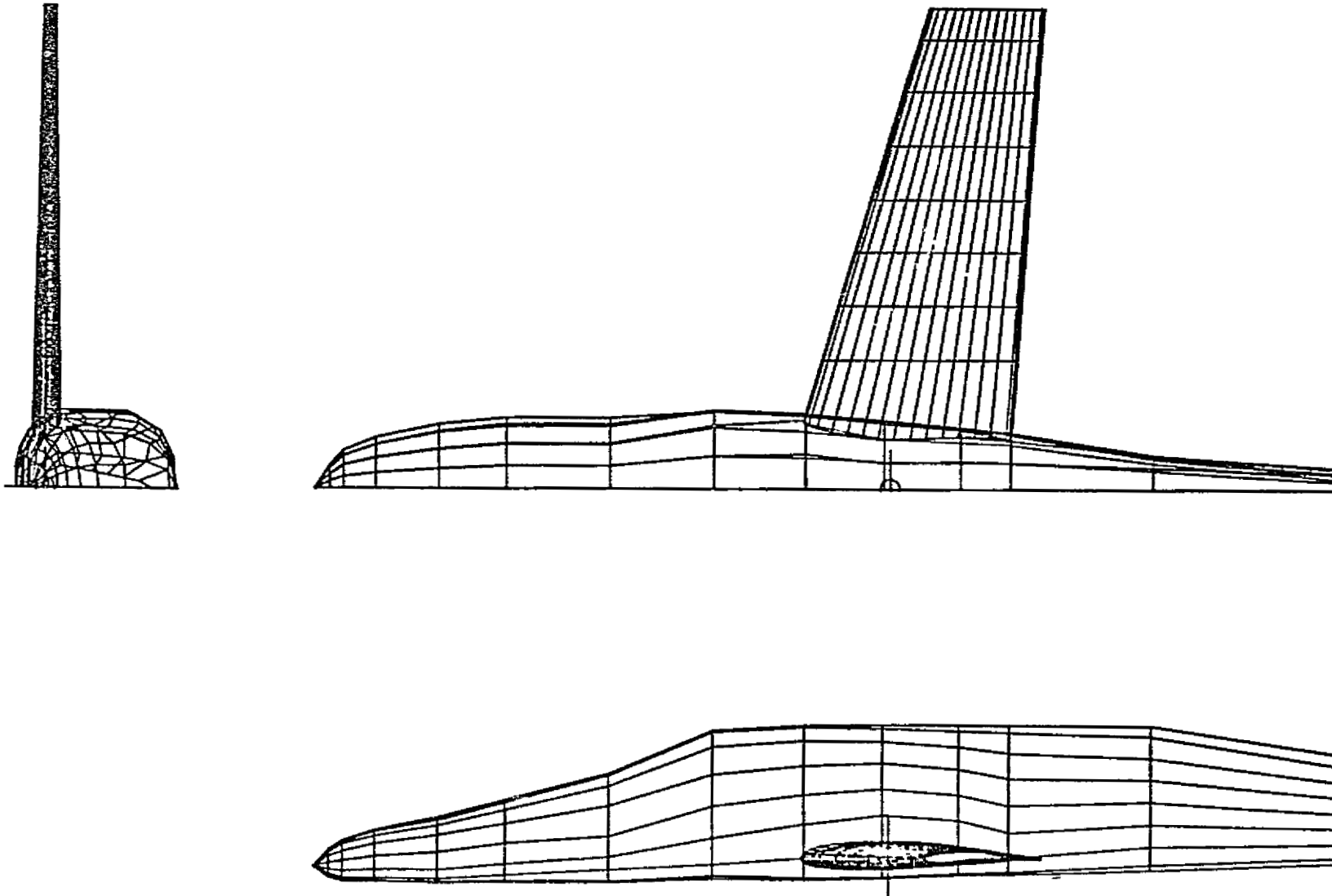
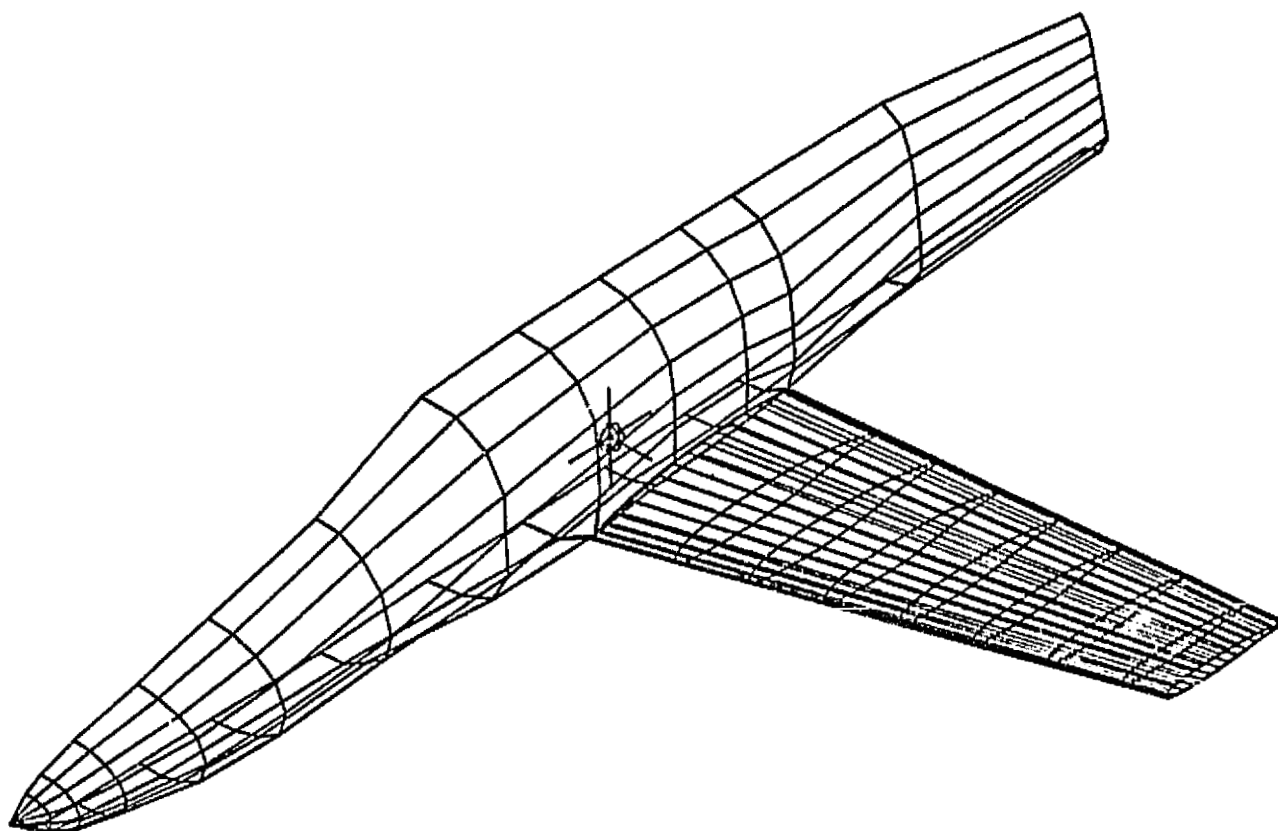

Figure D-8.—Shortened Blow-in-Door Inlet for 1041-133 and 1041-134



*Figure D-9.—Three-View of Airplane Source Network Used for TEA 230 Flow Field Analysis*





*Figure D-10.-Isometric of Airplane Source Network Used for TEA 230 Flow Field Analysis*

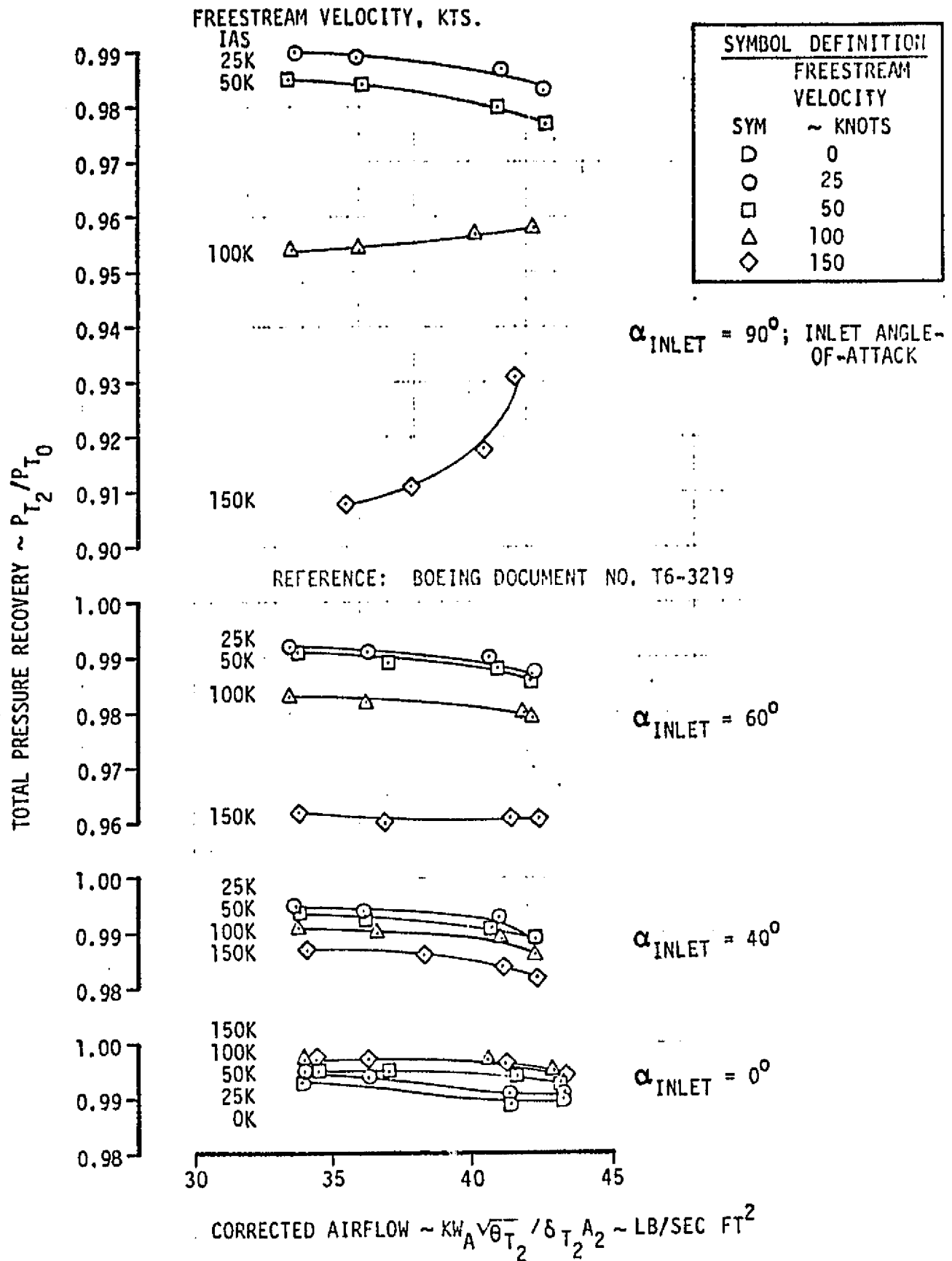

Figure D-11.-Blow-in-Door Inlet Recovery

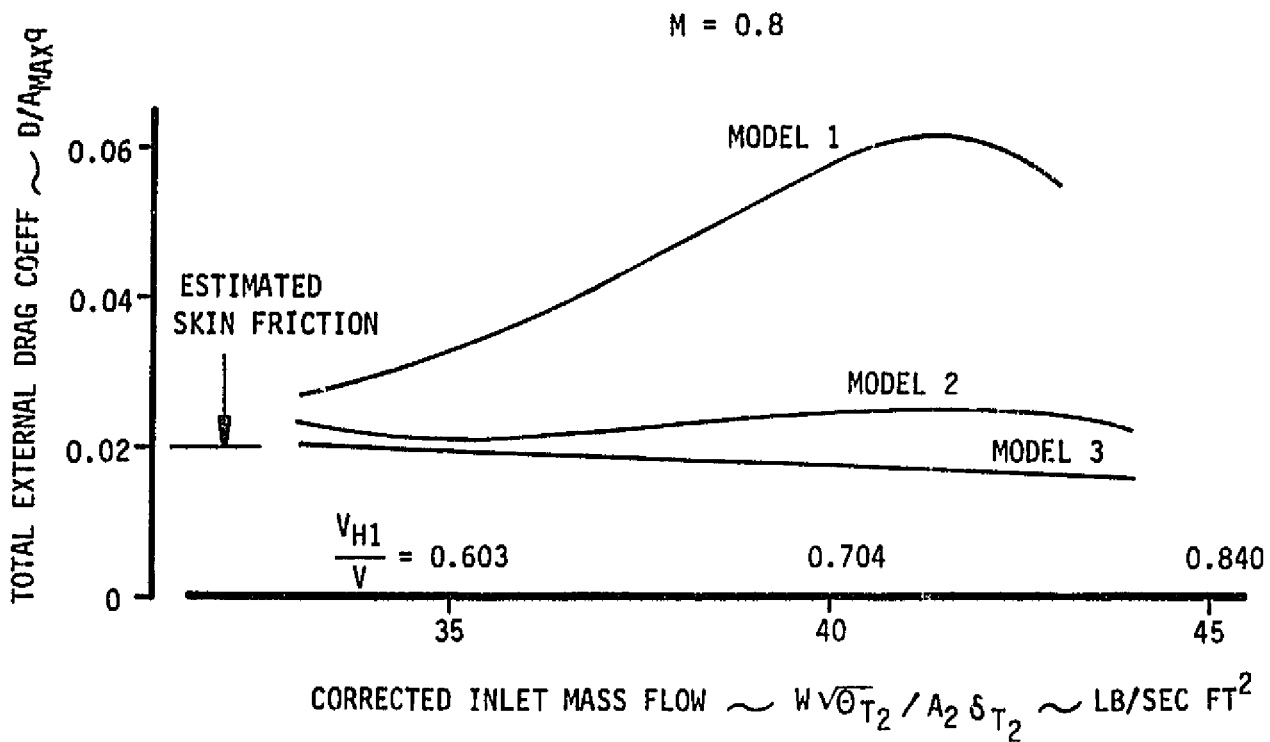
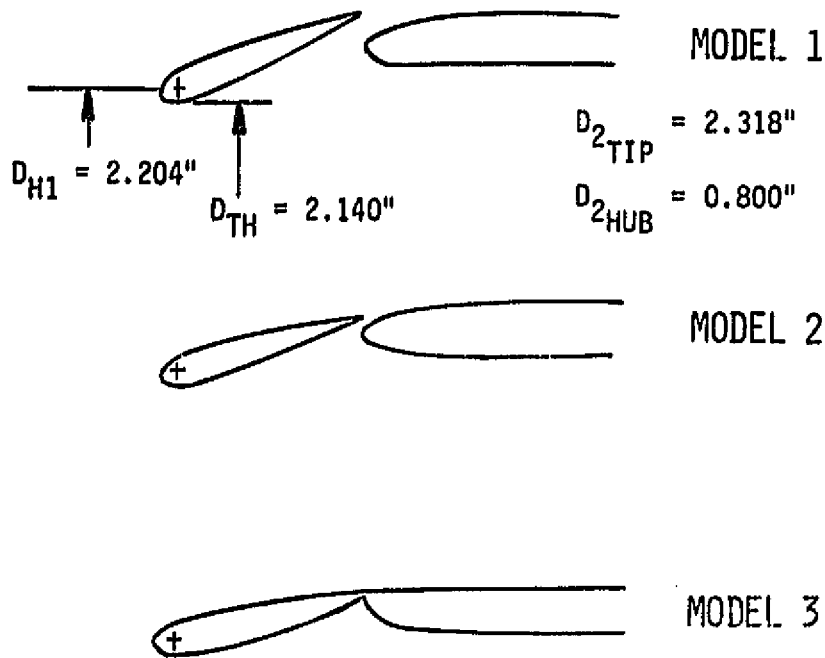

Figure D-12.-Blow-in-Door Inlet Cruise Drag

Table D-1.—Estimated Fan and Core Inlet Distorsions at Various Extreme Points in the Operating Placard

CONDITION	AIR SPEED (KNOTS)	TOTAL INLET ANGLE OF ATTACK (DEGREES)	CORRECTED FAN AIRFLOW LB/SEC/FT <sup>2</sup>	ESTIMATED % DISTORTION	
				$\frac{\Delta P_{T2}}{P_{T2}}$ X 100 FAN	CORE
1. VL FLARE	40	115	41.25	15 <sup>1</sup>	7.5 <sup>1</sup>
2. STOL LIFTOFF	75	70	41.25	12	7
3. APPROACH	75	90	31.0	9	6.7
4. APPROACH, MAX. CONTROL THRUST	100	80	36.9	14	10
5. APPROACH, MIN. CONTROL THRUST	100	80	20.0	<sup>2</sup>	<sup>2</sup>
6. APPROACH, MAX. CONTROL THRUST	125	60	31.0	9	7
7. APPROACH, MIN. CONTROL THRUST	125	60	16.2	<sup>2</sup>	<sup>2</sup>

<sup>1</sup> EXTRAPOLATED FROM DATA AT 90°.

<sup>2</sup> TEST DATA WAS NOT AVAILABLE AT THESE LOW AIRFLOW CONDITIONS BUT DISTORTIONS ARE EXPECTED TO BE LESS THAN 10%, BECAUSE OF THE VERY LOW COMPRESSOR FACE DYNAMIC PRESSURES.

<sup>3</sup>  $\frac{\Delta P_{T2}}{P_{T2}} = \frac{P_{T \text{ MIN}} - P_{T \text{ AVG}}}{P_{T \text{ AVG}}}$  for fan; and  $\frac{P_{T \text{ MAX}} - P_{T \text{ MIN}}}{P_{T \text{ MAX}}}$  for core.

Table D-2.—Comparison of Distortion Parameters

CONDITION	AIRSPEED KNOTS	CORRECTED AIRFLOW LB/SEC/C+2	INTERNAL MACH NO.	$\frac{\Delta P_T}{P_{T2}}$ LIMIT	$\frac{\Delta P_T}{q_2}$ LIMIT
TAKEOFF AND LAST PHASE OF VERTICAL LANDING	70	41.7	.60	.056	.28
APPROACH TO VERTICAL LANDING	150	18	.215	.15	4.42
	120	21.5	.26	.15	3.32
	100	25.5	.32	.15	2.10
	80	29.5	.375	.15	1.57
	40	34	.45	.15	1.14

Table D-3.-Inlet Flow Field From TEA 230 Analysis

INLET FLOW FIELD FROM TEA 230 ANALYSIS

AIRPLANE ANGLE OF ATTACK, $\alpha$	NACELLE INCIDENCE ANGLE, $\lambda$	UPWASH* (+ = UP) DEGREES	SIDEWASH* (+ = INBOARD) DEGREES	LOCAL VELOCITY* RATIO, $V_L/V_\infty$
0	0	-3.4	-2.2	1.08
	40 <sup>o</sup>	-2.7	-1.2	1.05
	60 <sup>o</sup>	-2.6	-1.1	1.04
	90 <sup>o</sup>	2.8	-1.1	1.03
5	0	-5.8	-3.2	1.10
	40	-4.2	-2.0	1.07
	60	-4.6	-1.9	1.05
	90	-4.7	-1.8	1.04
10	0	-8.3	-4.2	1.12
	40	-6.7	-2.8	1.07
	60	-6.7	-2.7	1.06
	90	-6.7	-2.5	1.04
15	0	-10.9	-5.1	1.14
	40	-8.8	-3.6	1.07
	60	-8.7	-3.5	1.07
	90	-8.7	-3.2	1.04
20	0	-13.5	-6.1	1.14
	40	-10.9	-4.4	1.07
	60	-10.8	-4.2	1.06
	90	-10.7	-4.0	1.04

\* IN THE CENTER OF INLET PLANE

## APPENDIX E - FAN NOZZLE VANES

Vanes are mounted at the exit of the fan nozzle to provide side force and yawing moment for the airplane when needed in vertical and transition modes. Airplane control studies have shown that adequate control will be provided by forces equivalent to vectoring the fan exhaust  $10^\circ$  from its normal direction.

The capability of vanes in the fan nozzle exit to vector the thrust of the lift-cruise engines for control purposes is about  $+10^\circ$ . Undeflected, both the vanes and the cross-shaft should produce negligible blockage compared to the 747 JT9D bifurcation. However, while the vanes are deflected, they will tend to cause some upstream blockage on the pressure side and some "negative" blockage on the suction side of the vane. The net result is similar to the effect of a large lifting surface in a wind tunnel: a small net blockage due to thickness and independent of angle-of-attack and an upwash due to lift. The magnitude of this upwash near the rotor and fan exit guide vanes should be small due to the large distance, 3 to 5 vane chords upstream, see Figure E-1. The original JT9D bifurcation, shown on Figure E-2, caused up to  $11^\circ$  change in flow direction in the stator plane, resulting in peripheral variations in fan back pressure, fan work and total pressure distortion and loss of stall margin. Since lift effects tend to decay faster than solid body effects, and distances are comparable, the effect of the deflected vanes should be smaller.

The effectiveness of the exit turning vanes has been analyzed by assuming they act as low aspect ratio wings with 30% chord, sealed plain flaps. This approach requires a double hinged arrangement; the first to permit overall vane deflection and the second for deflection of the flap. The exposed semi-span is fixed at 1.178 feet ( $t/c = .15$ ) and the force characteristics have been obtained parametrically as a function of span to chord ratio (Figure E-3). The values shown are for two vanes (one each side of the centerbody) and assume optimum vane and flap deflection. Included is a decrement in  $(L/q)$  of .36 to account for the centerbody). The fan nozzle exit Reynolds number was assumed equal to  $10^6$ .

Aspect ratio = 1 vanes result in an  $\frac{L}{q \text{ max.}} = 5.5$ . The average fan nozzle height is 1.178 ft., so the maximum side force lift coefficient  $C_L \text{ MAX} + \frac{(L/q/\text{max})}{1.178^2 \times 2} = 1.982$ .

The thrust of the fan can be expressed in an analogous coefficient form with fan nozzle area as reference area:

$$F_g = (\rho VA)_F \times V_F = (\rho V^2 A)_F = 2q_{FAN} A_{FAN}$$

$$C_F = \frac{F_g}{q_{FAN} A_{FAN}} = 2.0$$

The maximum vector angle is then the arc sine of the ratio of total vane area to fan nozzle area, since for the vanes chosen  $C_{L VANE} \approx C_F$

$$\text{arc sin} = \frac{2 \times 1.178^2}{15.46} = 10.4^\circ$$



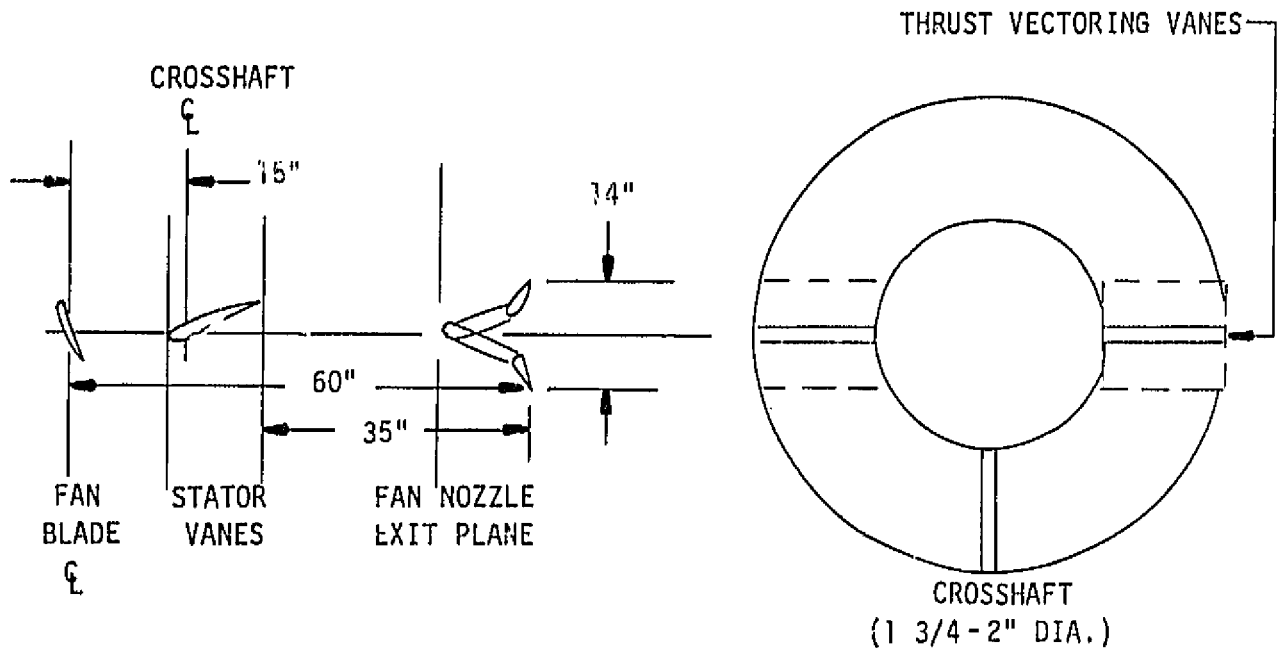

Figure E-1.-Blockage of Fan Flow Due to Thrust Vectoring Vanes

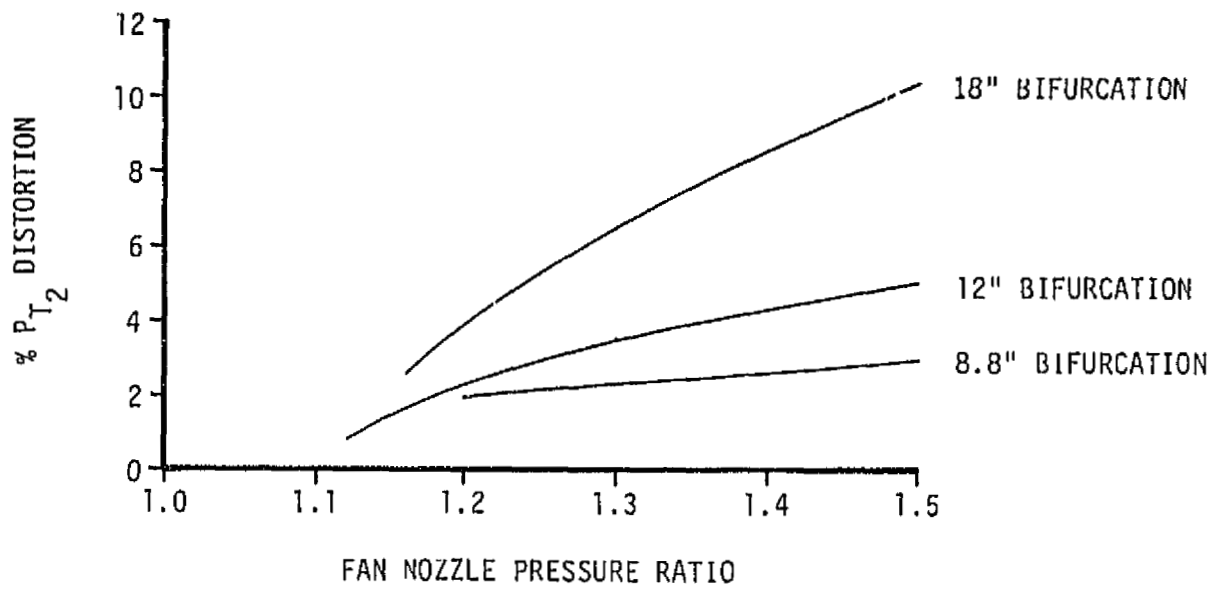

Figure E-2.—Effect of 747-JT9D Fan Nozzle Bifurcation on Fan Exit Total Pressure Distortion

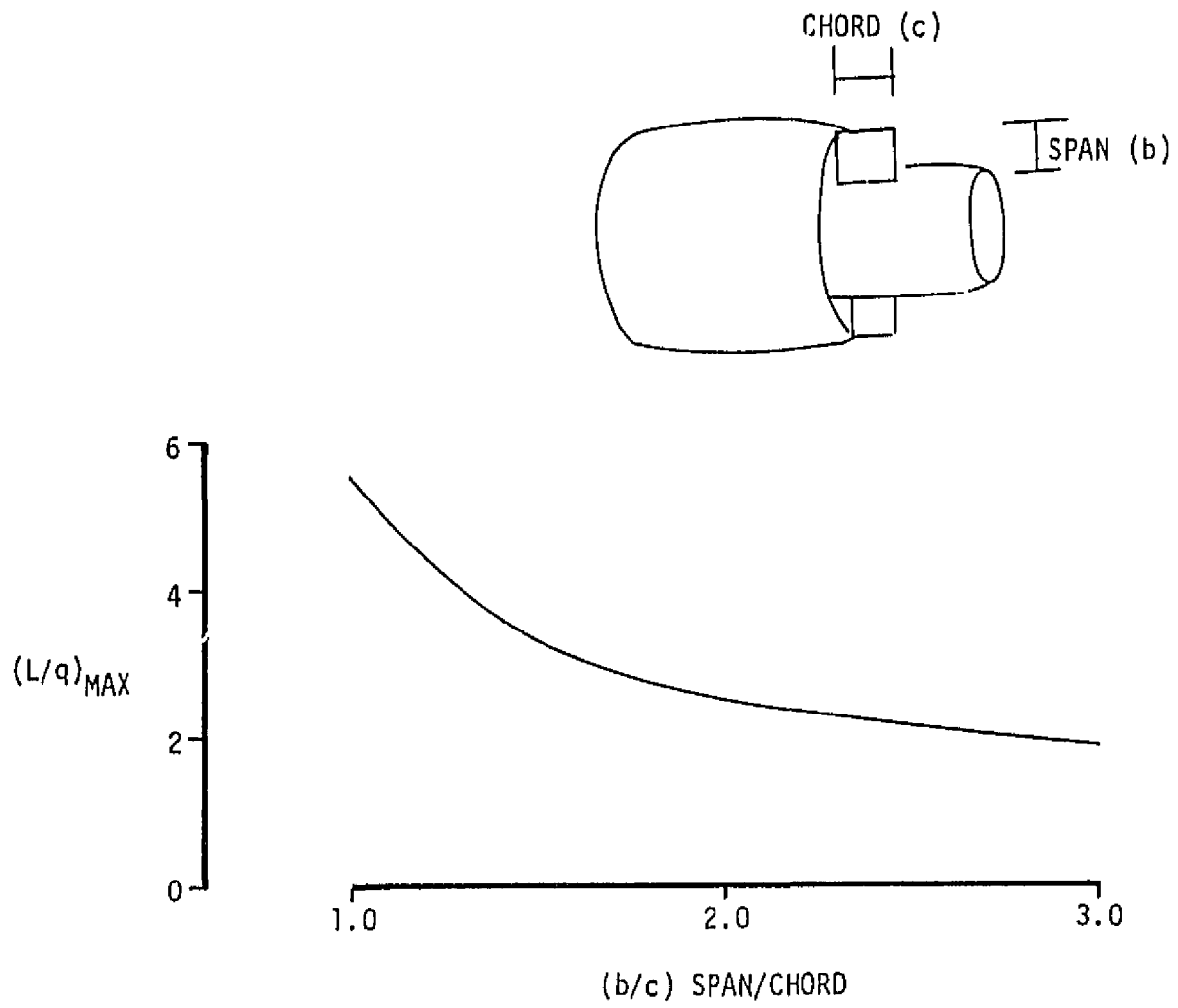

Figure E-3.—Jet Vane Maximum Lift

APPENDIX F - TRANSMISSION SPIRAL BEVEL GEAR LOAD AND VELOCITY EXPERIENCE

The transmission power capability requirements were determined by review of airplane thrust and control power requirements during normal and one engine-out operation. The resulting maximum power conditions are shown on Tables F-1 and F-2.

Gear design allowables for the 1041-133 will be no higher than those of current designs. We have selected gear tooth loading and gear pitch line velocity as two of several possible parameters to illustrate the relationship of the 1041-133 gears to other applications (Table F-1). Gear tooth loading is a function of both stress and size of tooth (diametral pitch). The larger size gears with proportionate teeth therefore can be expected to carry higher unit loadings without an increase in stress.

The direct comparison of drive system experience for several parameters (Table F3) shows that stress levels, gear loads, gear velocities and bearing velocities are within demonstrated capability. The overrunning clutch on the operational airplane will be resized to carry added torque. The higher overrun velocity which results is within the range which has been successfully run in a development program sponsored by USAAMRDL, Ft. Eustis Directorate. Although increased gear size near the limits of previous experience constitutes a design risk and although increased pitch line velocity near the limits of previous experience requires special attention to lubrication and the prevention of destructive stresses due to resonance, these two parameters do not tend to interact and compound the risks.

~~PRECEDING PAGE BLANK NOT FILMED~~

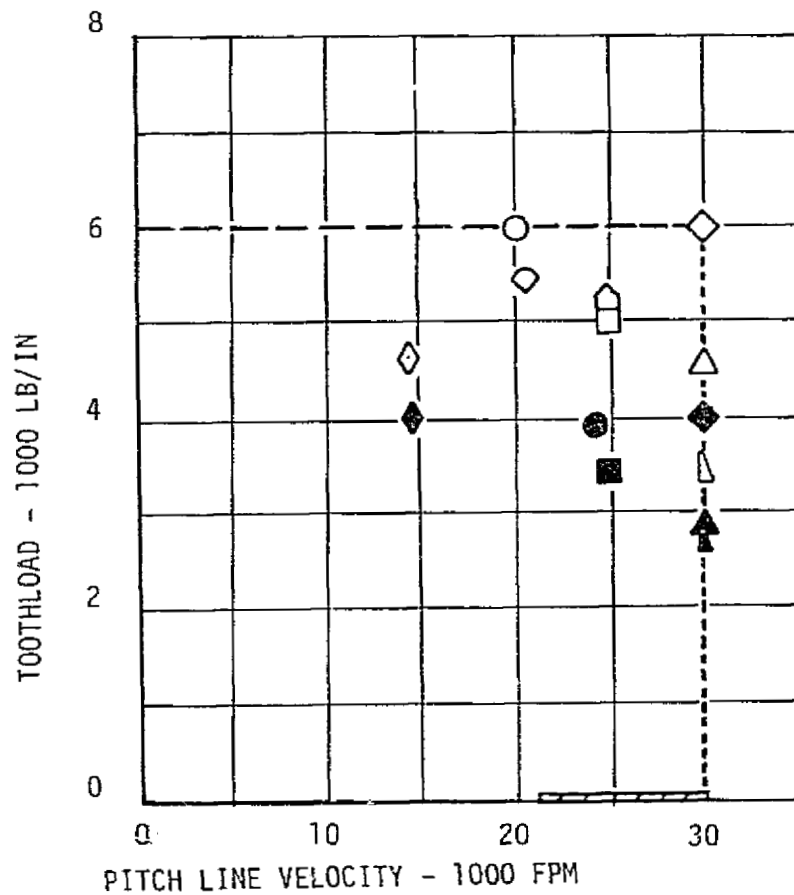

### LEGEND

- LOAD CAPABILITY ESTABLISHED BY HLH
- SPEED CAPABILITY DEMONSTRATED BY CH-47C
- HLH DESIGN\*
- HLH DESIGN\*
- ◇ CROSS SHAFT-OPERATIONAL AIRPLANE (1041-133-1) 100% ROLL-ONE ENGINE INOPERATIVE
- ◆ CROSS SHAFT (1041-133-1) 100% ROLL-NORMAL
- △ CROSS SHAFT-TECHNOLOGY AIRPLANE (1041-128) 100% ROLL-ONE ENGINE INOPERATIVE
- ▲ CROSS SHAFT (1041-133-1) 100% ROLL-NORMAL
- FWD FAN - (1041-133-1) 100% PITCH MANEUVER
- FWD FAN (1041-133-1) 100% PITCH MANEUVER
- ◇ CA47C MAXIMUM TEST }\*
- ◆ CH47C MAXIMUM DESIGN }\*
- ◇ CH47C MAXIMUM TEST }\*
- ◆ CH47C MAXIMUM DESIGN }\*
- ◇ GLEASON TEST
- ◇ AGEH HYDROFOIL SHIP
- ==== NOMINAL CLIMB, CRUISE, AND LOITER OPERATION (1041)
- \* DIFFERENT BEVEL SETS ON SAME MODEL AIRPLANE

Figure F-1.--Spiral Bevel Gear Experience

Table F-1.--Maximum Power Conditions--Two Engine, Three Fan

<u>LOCATION</u>	<u>MAXIMUM DESIGN CONDITION</u>	<u>SHAFT HORSEPOWER</u>
1. FWD FAN DRIVE, SHAFT & DISCONNECT CLUTCH	100% PITCH MANEUVER	10,747
2. LIFT/CRUISE FAN & PLANETARY	CLIMB	12,000
3. CROSS SHAFT & TEE BOX GEARING	OEI: 100% ROLL -30% PITCH	9,974
	AEO: 100% ROLL +30% PITCH	6,613
4. OVERRUN CLUTCH	OEI:	13,600
	AEO:	12,400
5. AGB		100-200

OEI - ONE ENGINE OPERATING  
 AGB - ACCESSORY GEARBOX  
 AEO - ALL ENGINES OPERATING

Table F-2.-Bevel Gearing VISTOL

<u>HP PER ENGINE</u>	<u>LOCATION</u>	<u>CONDITION</u>	<u>HP PER MESH</u>	<u>VEL. FPM</u>	<u>LOAD LB/IN.</u>
13,600 (OEI)	X-SHAFT	100% ROLL	9974	30,000	6000
12,400 (AEO)	X-SHAFT	100% ROLL	6613	30,000	4000
10,450* (OEI)	X-SHAFT	100% ROLL	7700	30,000	4600
8,500* (AEO)	X-SHAFT	100% ROLL	4500	30,000	2800
12,400	FWD FAN	100% PITCH	10747	25,000	5000
8,500*	FWD FAN	100% PITCH	7400	25,000	3400

\*XT-701 ENGINE - TECHNOLOGY AIRPLANE

OEI - ONE ENGINE INOPERATIVE

AEO - ALL ENGINES OPERATIVE

Table F-3.-Boeing Helicopter Drive Systems Experience Related to Navy/NASA VISTOL  
Airplanes

<u>COMPONENT OR PARAMETER</u>	<u>EXPERIENCE</u>	<u>EXPERIENCE DEMONSTRATED RELATED TO:</u>	
		<u>TECHNOLOGY AIRPLANE</u>	<u>OPERATIONAL AIRPLANE</u>
USE OF VASCO X-2 STEEL GEARS	1650 HOURS INCLUDING 1500 HOURS (UTTAS) AND 150 HOURS (HLH)	125% OF V/STOL STRESSES	EQUAL TO V/STOL STRESSES
LARGE BEVEL GEAR DESIGN	STRAIN SURVEYS, FINITE ELEMENT ANALYSIS, DAMPING TECHNIQUES AND EXCITATION TESTING	DIRECTLY APPLICABLE	
GEAR VELOCITY OF 30,000 FPM	300,000 AIRPLANE HOURS (CH47C)	EQUAL	EQUAL
HIGH SPEED SHAFT RELIABILITY	1,500,000 AIRPLANE HOURS (CH47A, B, C)	DIRECTLY APPLICABLE	
OVERRUN CLUTCH TORQUE AND VELOCITY	50 HOUR DEVL TEST AND 200 HOUR BENCH TEST (HLH)	EQUAL	60% OF TORQUE 85% OF VELOCITY
BEARING VELOCITY	HIGH SPEED TAPER BEARINGS TESTED 3000 HOURS (RIG, HLH BENCH AND DSTR)	EQUAL	EQUAL



## APPENDIX G

### HLH TRANSMISSION GEARING EXPERIENCE

The HLH transmission combiner box collects the output from three 701 engines and drives two output shafts. During initial tests of the HLH aft and combiner transmissions, failure of spiral bevel gears occurred. These were the input pinion to the aft transmission and the collector gear in the combiner transmissions. Investigation revealed that the failures were caused by high bending stresses in the roots of the teeth. This had been caused by adverse load distribution across the teeth and high frequency vibratory response to gear mesh excitation. It was found that damping rings were necessary to reduce resonant stresses and increased rim thicknesses of both the pinion and gear were required to improve load distribution.

The fixes are incorporated in the HLH prototype helicopter scheduled to fly in mid 1976, and will be bench tested in 1975. An excerpt from the Vertol paper presented by K. K. Grina, Director of Engineering to the 2-5-75 Royal Aeronautical Society Meeting which discusses the problem follows.

**PRECEDING PAGE BLANK NOT FILMED**

## HELICOPTER DEVELOPMENT AT THE BOEING VERTOL COMPANY

### HLH Transmission Testing

During the initial tests of the HLH aft and combiner transmission, we experienced failures of spiral bevel gears: the input pinion in the aft transmission, and the collector gear in the combiner transmission. We have determined that these failures were caused by high bending stresses in the roots of the teeth which resulted from adverse load distribution across the teeth. High frequency vibratory response to gear mesh excitation contributed to the failures also.

We conducted strain gage surveys, measuring stresses in the tooth roots, both statically and dynamically, using micro-miniature gages. We used a telemetry system for the transmittal of data. Figure 6-1 is a three-dimensional plot prepared from static test data showing measured stresses across the face of the gear at various instants of time (roll angle). The movement of both compression stress and tension across the face is easily visualized.

The results of a typical stress survey, comparing dynamic and static measurements, is shown in Figure 6-2. The dynamic data measurements have either equalled or exceeded the static test results by about 10%. These effects are not true dynamic (rpm)<sup>2</sup> effects, but the result of variations resulting from meshing the instrumented tooth with each tooth of the mating gear.

Gear resonant frequencies are first evaluated on a stationary gear using air sirens. A pulsating air jet whose frequency can be varied by changing either the number of holes in the "head", or by varying the "head" rpm, provides the excitation source. A roving accelerometer is used to produce Lissajous patterns against a reference pickup to identify mode shapes.

The results of a typical siren test are displayed as the zero rpm points on the Campbell diagram shown in Figure 4-4. Even though the gears operate at high speed, we found no discernible rpm effect on frequency. The figure also shows the rpm at which the resonances occur. For those not familiar with gear resonance, it is pointed out that, because tooth impact is fixed in space while the gear is rotating, there exists both a rearward and a forward traveling wave that results in resonances other than at a one-tooth excitation frequency both above and below by an amount established by the mode number.

Gear resonant frequencies are best identified during dynamic tests using a spectral analyzer. The use of a Visicorder time history spectral analysis, such as shown in Figure 4-3 permits accurate evaluation of the resonant frequency and rpm. This data can then be plotted as shown to illustrate the stress sensitivity of each mode while passing through resonance.

The results obtained can also be plotted on a Campbell diagram, such as that shown in Figure 4-4. The correlation found in HLH tests between the static siren tests and the dynamic measurements has been excellent. It was initially thought that frequencies established from siren tests on isolated gears would change when installed in the transmission. Tests to date have indicated virtually no installation effects on the fundamental gear resonant diametral modes.

The stress cycles accumulated while operating gears at resonance can be awesome when considering the frequency of stressing. For example, with a 12,000 cps resonance, stresses above the endurance limit could cause a failure in only 10 minutes of operation. For this reason, adequate damping is a must to maintain the resonant stresses at a very modest level.

There is no direct analytical analysis available that defines the type and amount of damping required or achievable. Figure 4-2 shows, however, what can be accomplished by changes in damping. These tests, plus others conducted both on HLH and CH-47 gearboxes, led to a semi-empirical relationship that is currently used to

$$Wt_{\text{damping ring}} = 0.15 \times (Wt_{\text{gear head}})^{3/4}$$

size the damping ring so that resonant stresses at their worst are less than 5,000 psi.



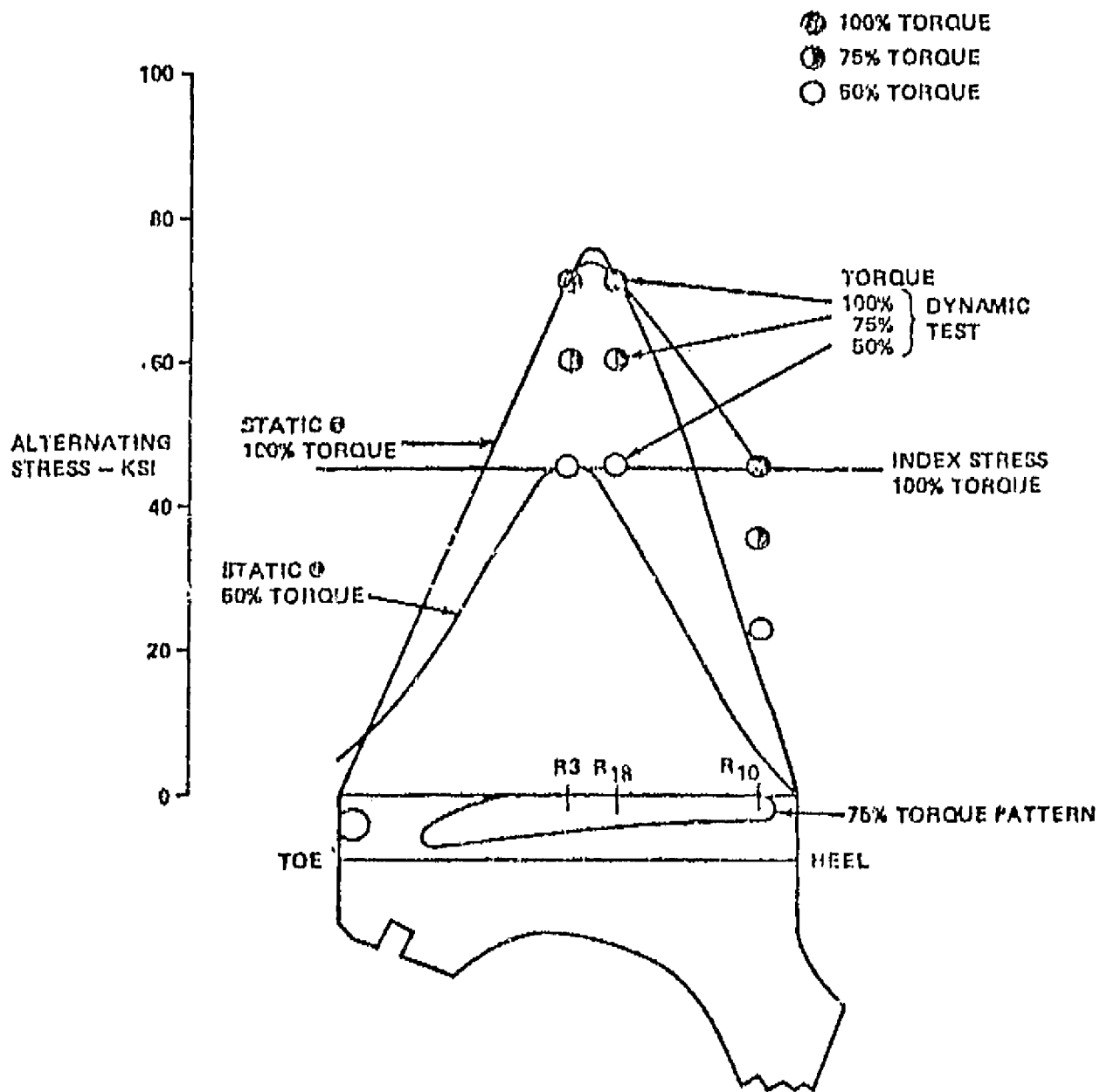

Figure G-2-HLH Aft Pinion Tooth Pattern and Stress Distribution

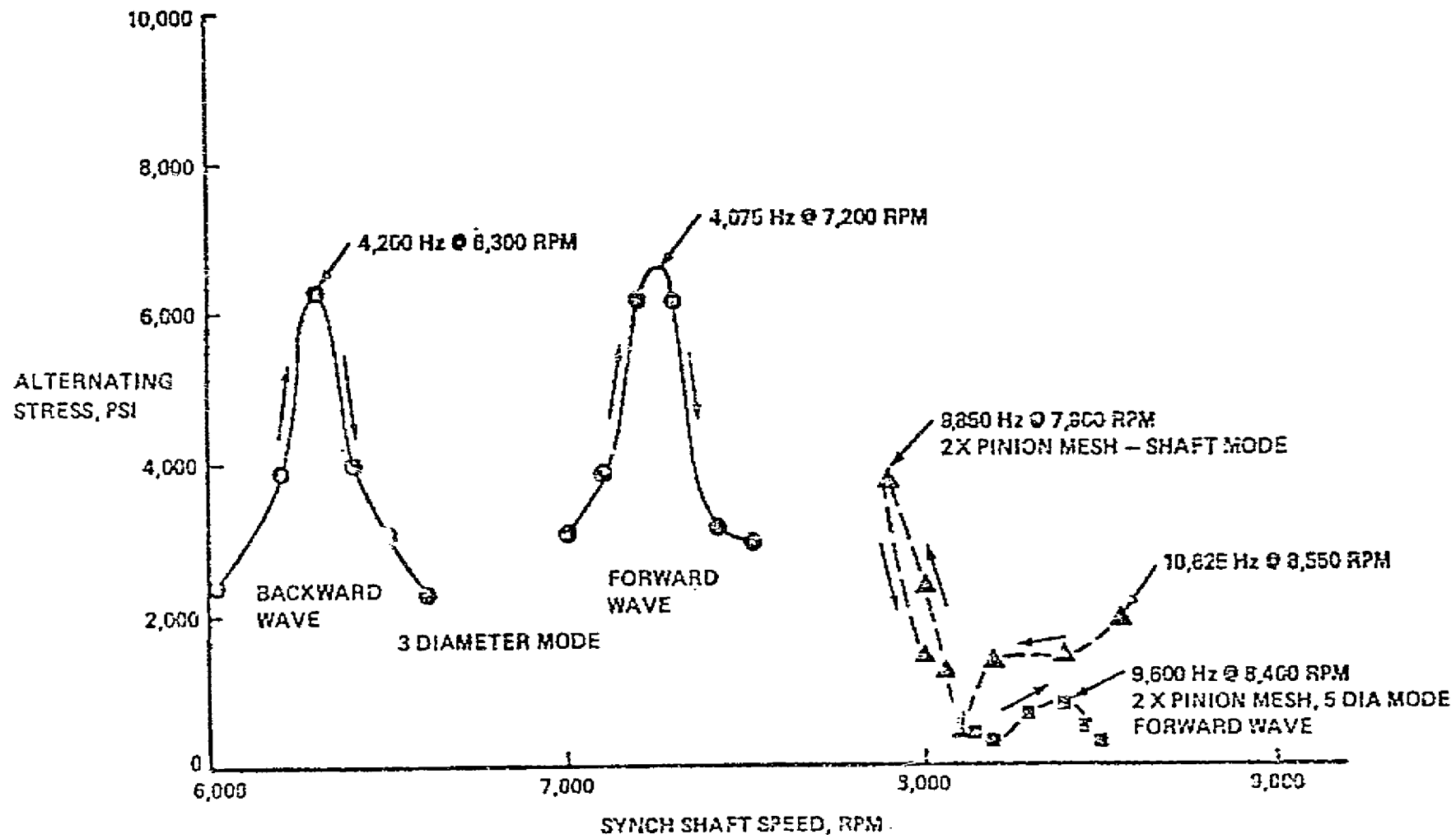

Figure G-3.-HLH Aft Pinion Resonant Stresses for Critical Modes

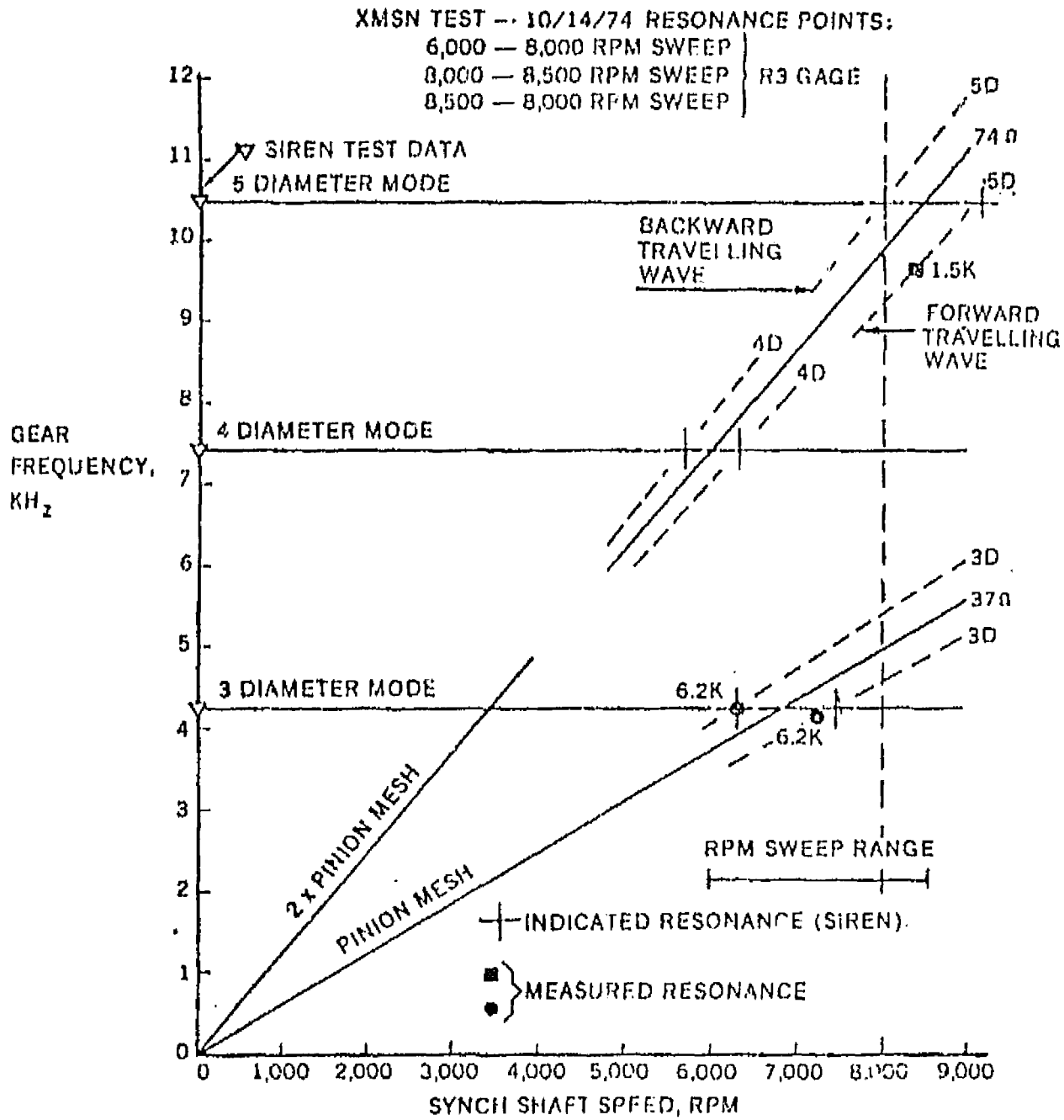

Figure G-4.—Campbell Diagram for HLH Aft Pinion



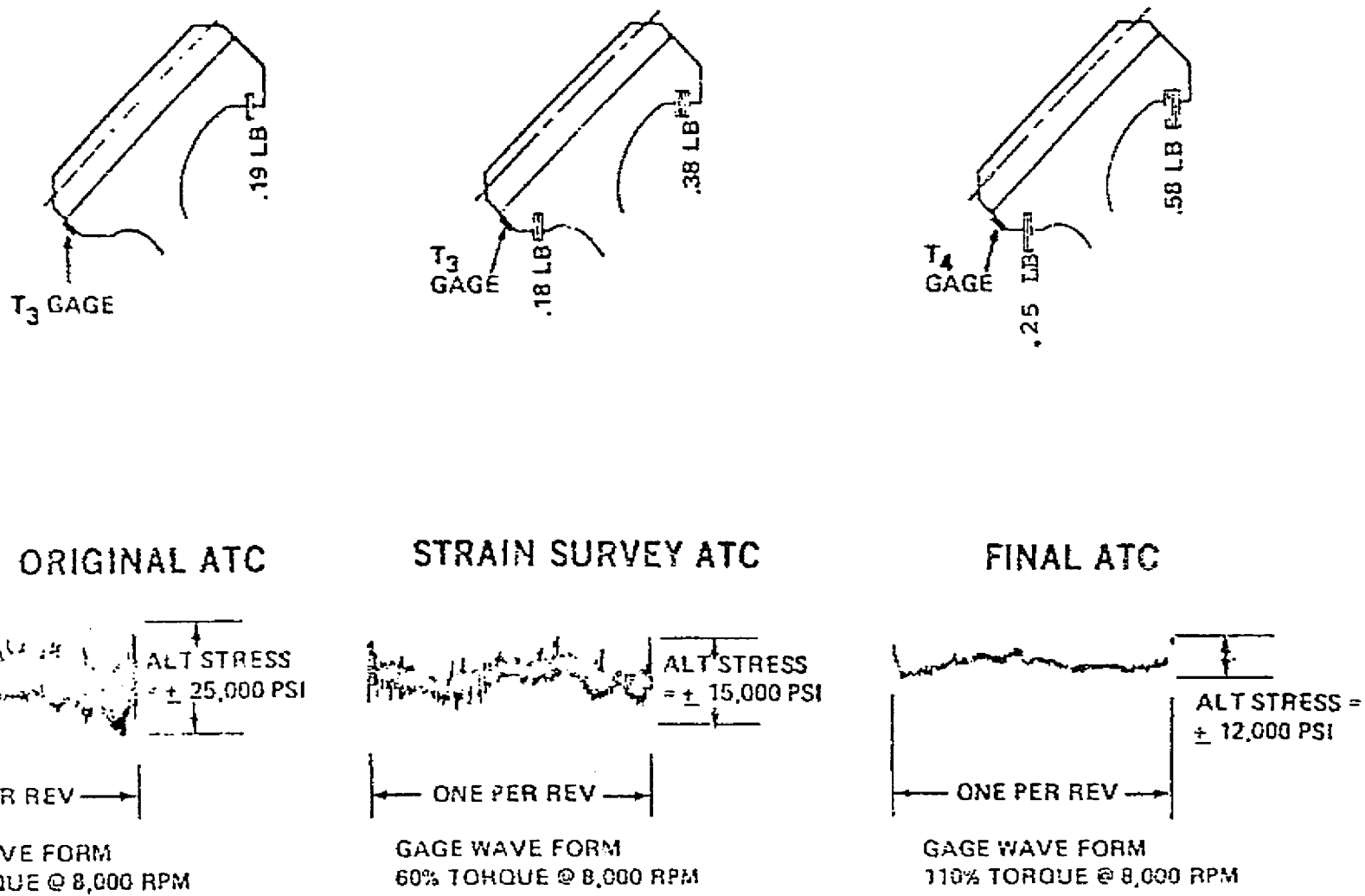

Figure G-5.—Aft Transmission Bevel Gear Reduction of Gear Resonance Through Increased Damping Ring Weight

## APPENDIX H - TAKEOFF AND LANDING TIME HISTORIES

The time history of several types of takeoffs and landings are discussed in this section. The takeoffs are shown first.

The takeoff time history shown on Figure H-1 is a constant attitude transition from hover to 162 knots. The liftoff and initial climb to an altitude out of ground effects is not shown. Takeoff power setting is maintained and the lift/cruise fan thrust is vectored for acceleration. As the airplane picks up speed and the wings share the airplane weight, more thrust can be used for acceleration. A peak acceleration of 0.5 g's is reached at 120 knots. The takeoff is at a gross weight of 32,400 lbs. (maximum hot day VTOGW). It takes 23 seconds to reach 162 KTAS (120% power off stall speed). The peak nacelle incidence rate used is a moderate 5<sup>0</sup> per second.

Figure H-2 is a short takeoff transition from liftoff to flight speed. The acceleration to liftoff is described in 3.3.3 and shown in Figure 3.3.3-9. The takeoff is made at a weight of 37,750 lbs. The performance is shown as a constant altitude transition to aerodynamic flight. The time history starts at 85 KTAS and it takes 17 seconds to accelerate to 174 KTAS (120% power off stall speed). The peak nacelle incidence rate required is about 4<sup>0</sup>/sec. The airplane is ready to convert to aerodynamic flight about 0.7 nautical mile after leaving the deck.

Two types of transitions to a vertical landing are shown. Figure H-3 shows a two segment approach and Figure H-4 shows a "rainbow" variable gamma approach. These patterns were examined to provide some insight to the landing vector requirements. They are not the limits of landing transition capabilities.

The two segment approach (Figure H-3) arbitrarily at 200 knots. The airplane is in the V/STOL mode. The airplane is decelerated to an air speed of about 100 knots holding a constant altitude (-0.20g's deceleration is used). At 100 knots constant descending flight path angle (-15<sup>0</sup>) is established. The deceleration in the descent is 0.1g's. To reach zero speed at this deceleration rate along this flight path the initial altitude is 1640 ft. It takes about two nautical miles and 84 seconds to make the approach. The peak nacelle incidence rate encountered is 3<sup>0</sup>/second. The nacelle angle of attack at 100 KTAS is 72<sup>0</sup>.

The variable gamma approach combines a constant rate of descent and a constant deceleration. The approach profile is parabolic from initial altitude to touchdown ("rainbow profile"). Time history is shown for a 0.15 g's deceleration and a rate of descent of 1000 feet per minute.

The approach takes about 70 seconds and 2 nautical miles. The initial altitude is 1180 ft. The peak nacelle incident rate is  $4.5^\circ/\text{second}$ .

1041-133-1  
 VERTICAL TAKEOFF  
 $\delta = 0^\circ$ ,  
 G.W. = 32 400 LBS  
 90° F SL  
 NOSE FAN OPERATING  
 $F/W = 1.05$

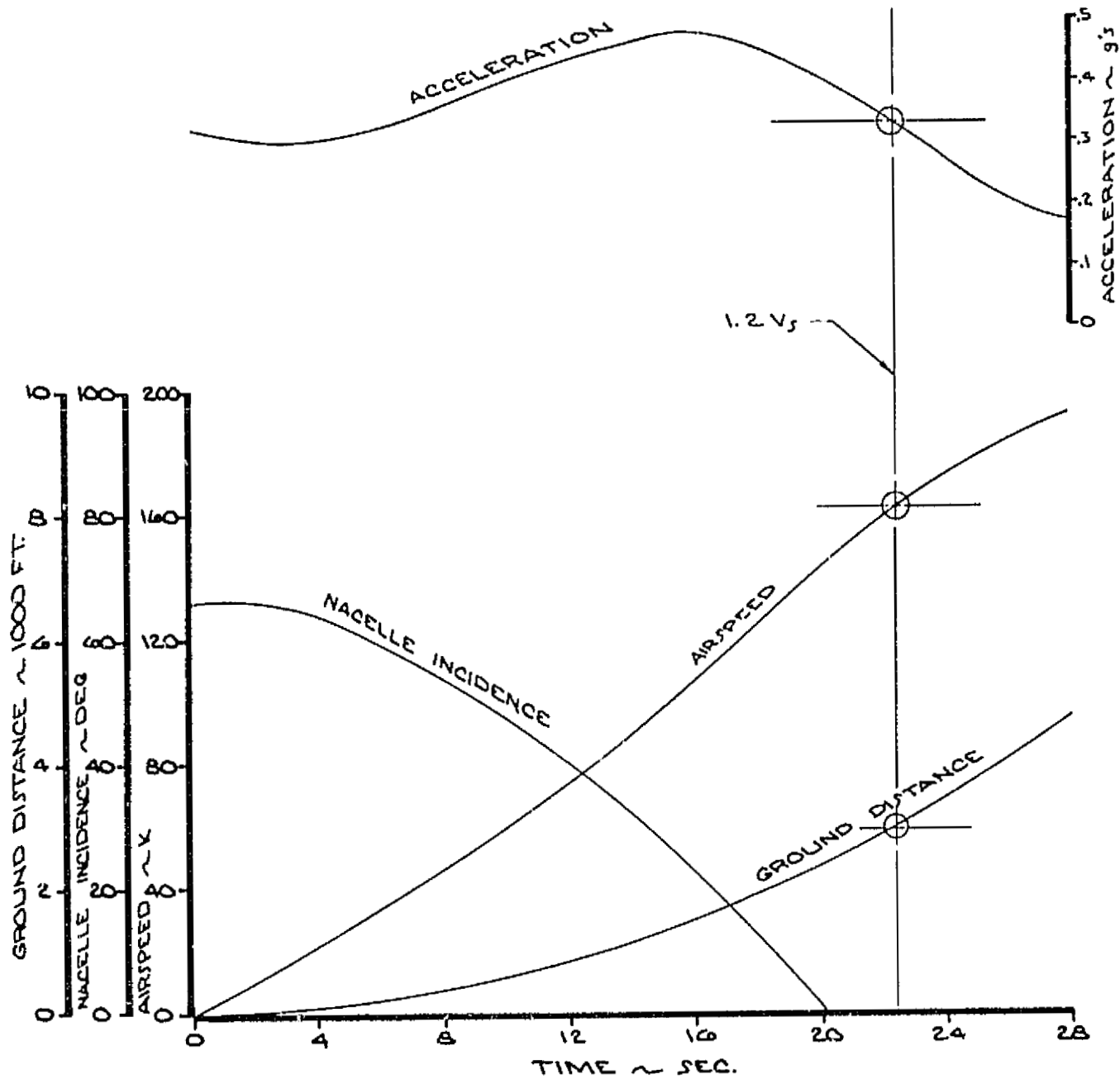

Figure H-1.-VTO Time History G.W. = 32 400 lbs

1041-133-1  
 SHORT TAKEOFF  
 $\delta = 0, \alpha = 8^\circ$   
 G.W. = 37750 LBS

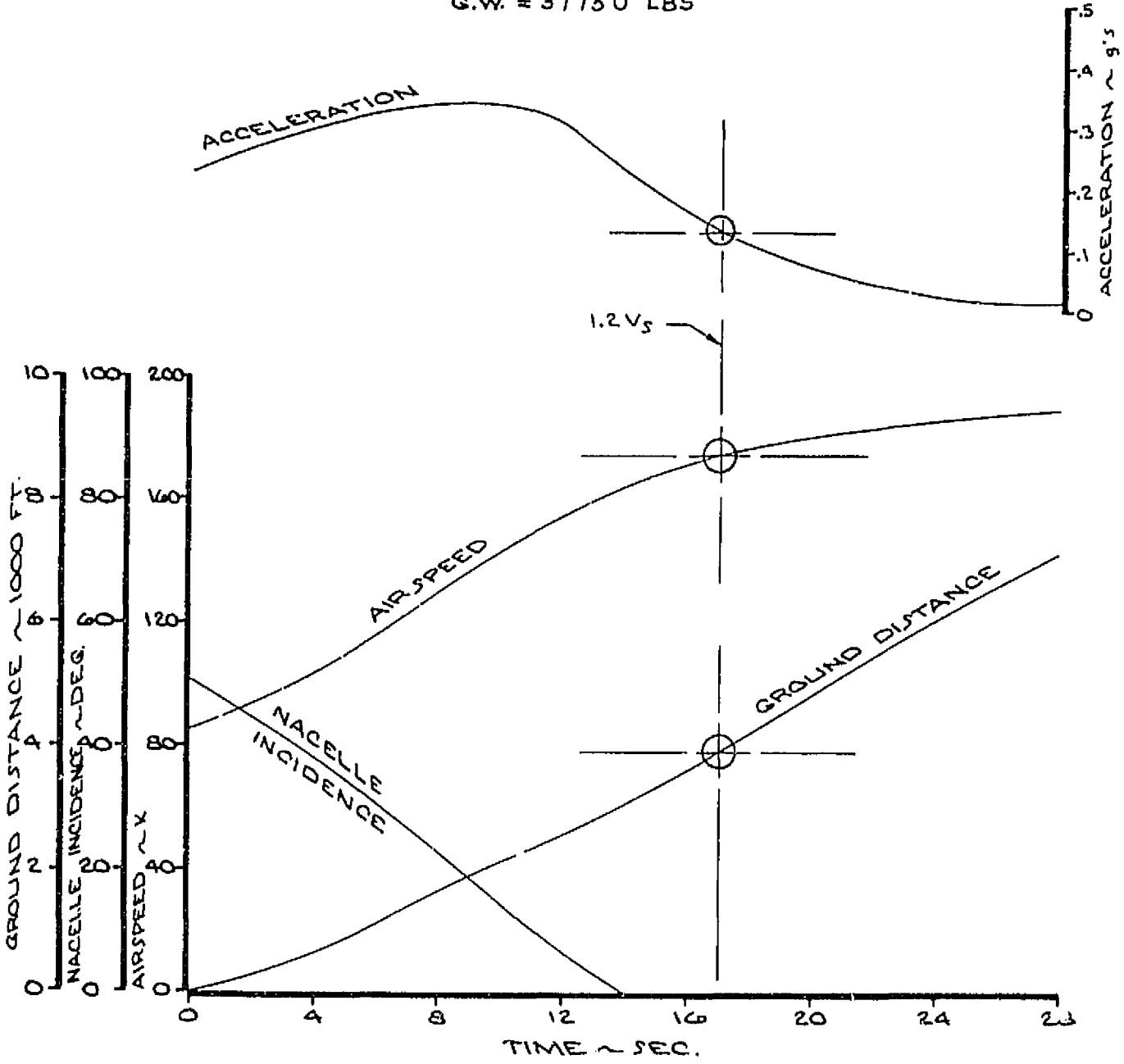

Figure .H-2-STO Time History

1041-133-1  
 TWO GAMMA APPROACH  
 GW = 32,400 LBS

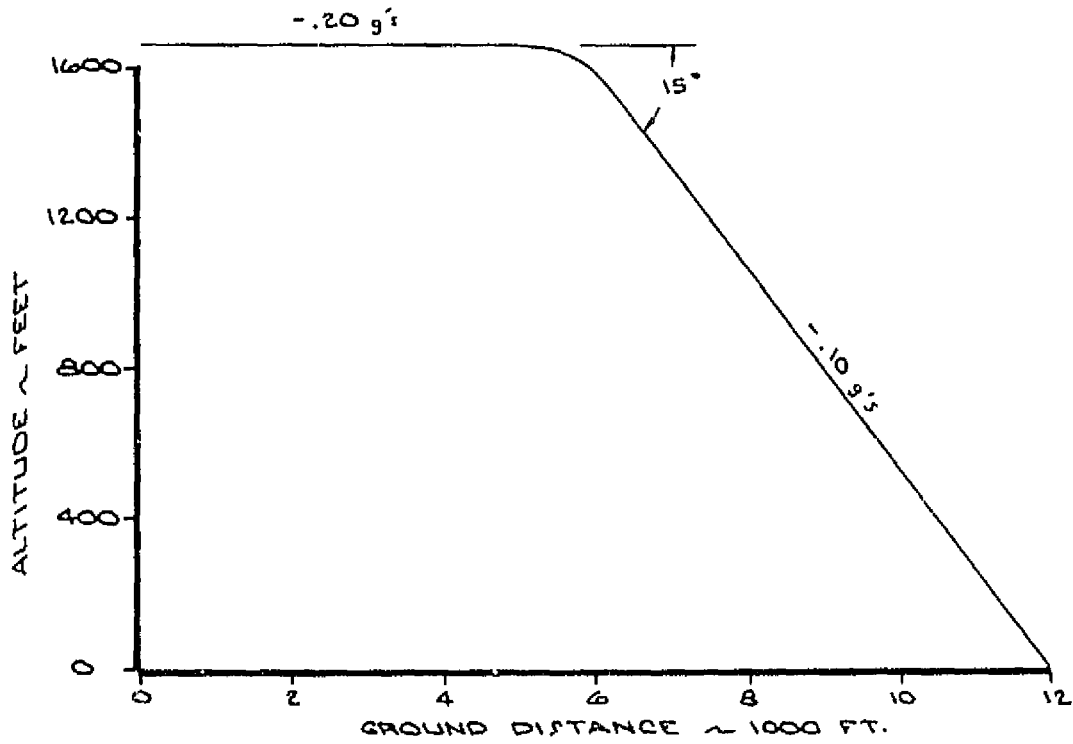
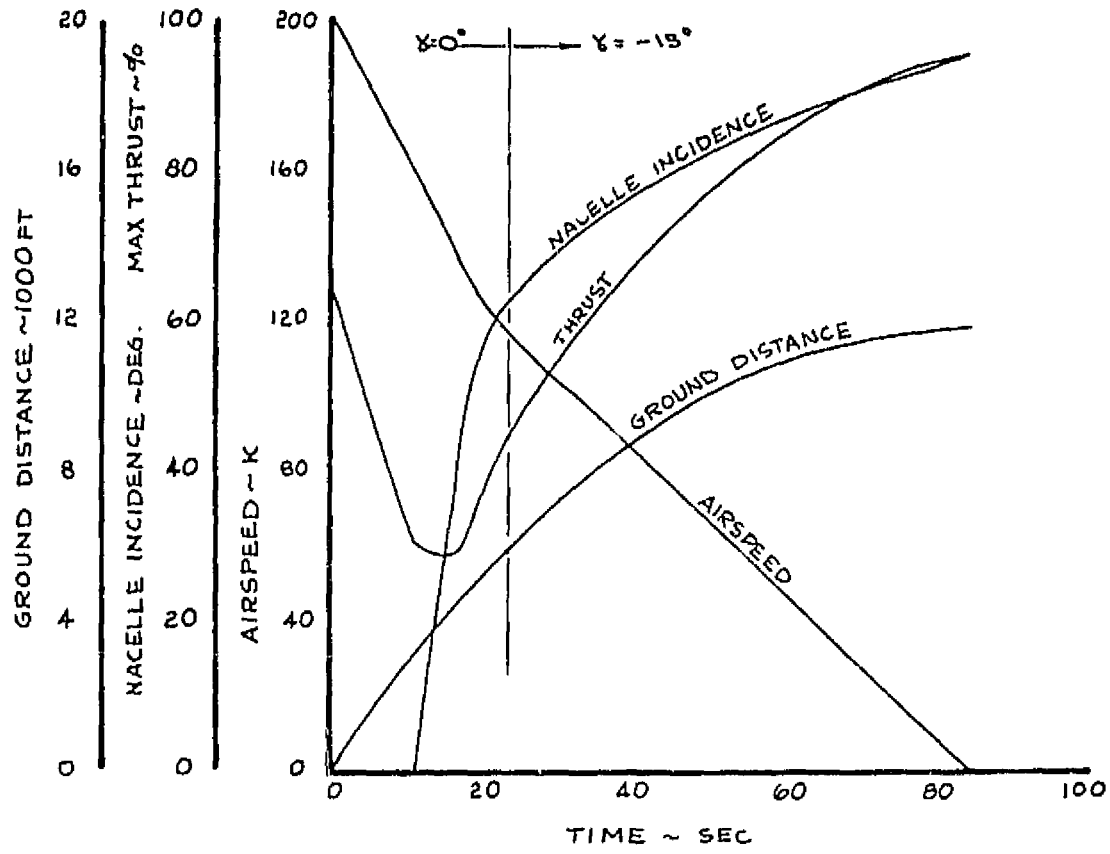

Figure H-3.-Two Segment Approach G.W. = 32 400 lbs

1041-133-1

RAINBOW APPROACH TO A VERTICAL LANDING  
G.W. = 25000 LBS.

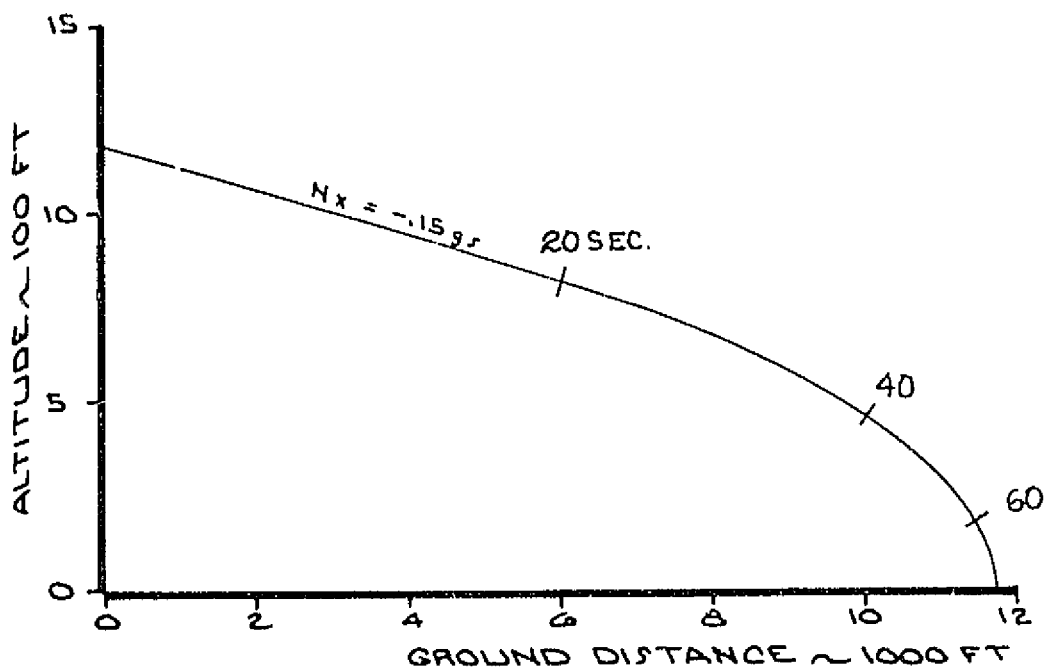
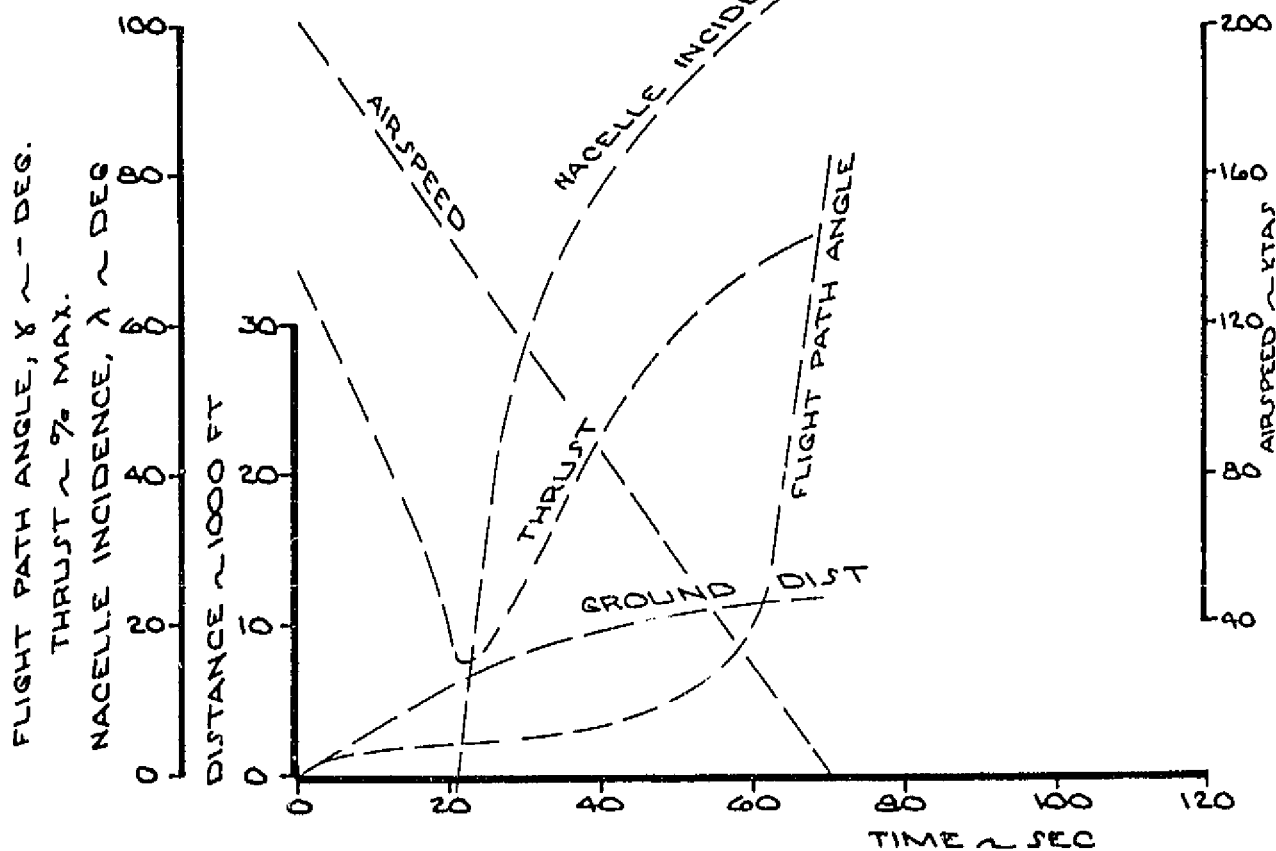

Figure H-4.-Variable Gamma Approach G.W. = 52 000 lbs

## APPENDIX I - WEIGHT ANALYSIS METHOD

A discussion of the methods used to predict the weight of the NASA/Navy V/STOL configurations is presented.

This analysis is based on the selection and application of a reliable parametric weight analysis method, in conjunction with the NASA/Navy V/STOL design criteria, to determine the preliminary weight of the ASW configuration proposed by The Boeing Company.

The method is included among the Navy weight analysis resources; it is updated frequently and has been used by The Boeing Company since the mid-1960's with consistent results in areas of identifying significant weight considerations of new aircraft designs.

Weight validation information is presented in the form of correlating data, operating weight comparisons of VTOL aircraft and actual versus estimated weight. A population of 11 USN aircraft are included in the validation and correlation data which have been prepared for 41 aircraft sample (sufficiently large enough to eliminate sample size errors), but more specifically during this study actual weight information on the C-2 and S-3A have been used to test and calibrate the weight analysis method.

### Percent Operating Weight Versus Weight Prediction Method

Application of the Boeing preliminary weight analysis method produced 50% of the operating weight. From the statement of work recommended guidelines were used in the development of avionic and payload system weights. Further analysis by Boeing particularly in the avionics area established these as excellent sources of weight information producing 13% of the results. Propulsion system weight elements, engines, lift fans and transmission components (gear boxes, shafts, clutches, etc.) are based on engine and transmission manufacturer component weight quotations accounting for 27% of the weight. Ten percent of the weight has been derived directly from Lockheed S-3A aircraft actual weight data, see Table I-1.



### Typical Parametric/Statistical Weight Method

The wing weight method is typical of the approach used to produce structural propulsion and fixed equipment group weights. The wing weight is identified in four areas that serve primary functional purposes, the structural box, lift devices, lateral controls and secondary structural items, see Table I-2. The weight of these elements are predicted as a function of the significant design parameters that affect and create this weight. Approximately 25 design parameters are involved in the preliminary design weight analysis of the wing.

### Lift/Cruise Engine Pod Rotation

The engine rotation weight allowance was determined from actual weight and thrust information. The data presented in Table I-3 has been developed from VTOL aircraft with propulsion rotation requirements similar to the Model 1041-133-1.

### Advanced Technology Weight

A potential of 15% weight improvement (1400 lbs) through widespread use of advanced technology structural materials is shown on Figure I-1. In that the 15% improvement implies technology development which may or may not occur, an improvement of 10% (about 900 lbs.) is used in this study. As a result, the operational airplane weight analysis has a 500 lb. weight contingency in advanced structural technology considerations.

### Operating Weight Versus Gross Weight

The propulsion, weight and aerodynamic mission sizing analysis of the operational ASW configuration (Model 1041-133-1) produced an operating weight to gross weight ratio of 0.623. The relationship of this ASW information to a group of helicopter and V/STOL aircraft is presented in Figure I-2 and the V/STOL ASW weight ratio plots near the curve of the mean line through this data. Note the C-2A and S-3A aircraft information has been included.

### Actual Weight Versus Estimated Weight

The analysis of 41 aircraft by the method described in this section produced the results presented on Figure I-3. Some of the capabilities of the method are: the ability to predict aircraft weight regardless of size over a wide range of aircraft functions, whether passenger, cargo, fighter class or strategic; and the ability to predict aircraft weight within one sigma standard deviation of  $\pm 5\%$ . The differences for V/STOL operational features between the ASW configuration and the population of aircraft presented here have been accounted for.

% IMPROVEMENT IN STRUCTURE WEIGHT

WING	26
H. TAIL	19
V. TAIL	19
BODY	17
GEAR	8
NACELLE	11
<u>TOTAL</u> ▷	<u>15</u>

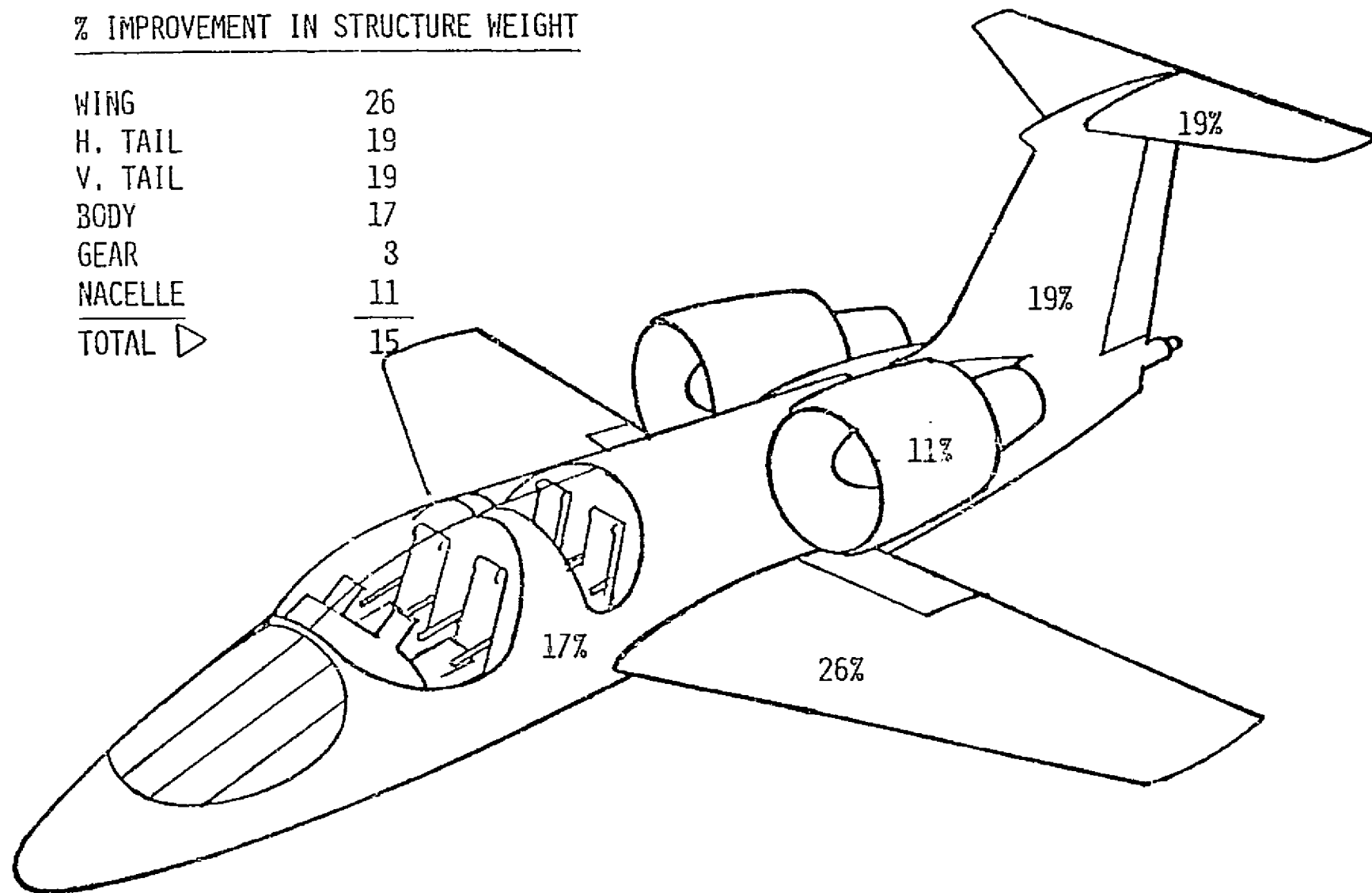

▷ WEIGHT REDUCTION EQUIVALENT TO 1400 LB. ON MODEL LCA - 133-1

Figure I-1.-Advanced Technology Weight

2.4

ORIGINAL PAGE IS  
OF POOR QUALITY

285

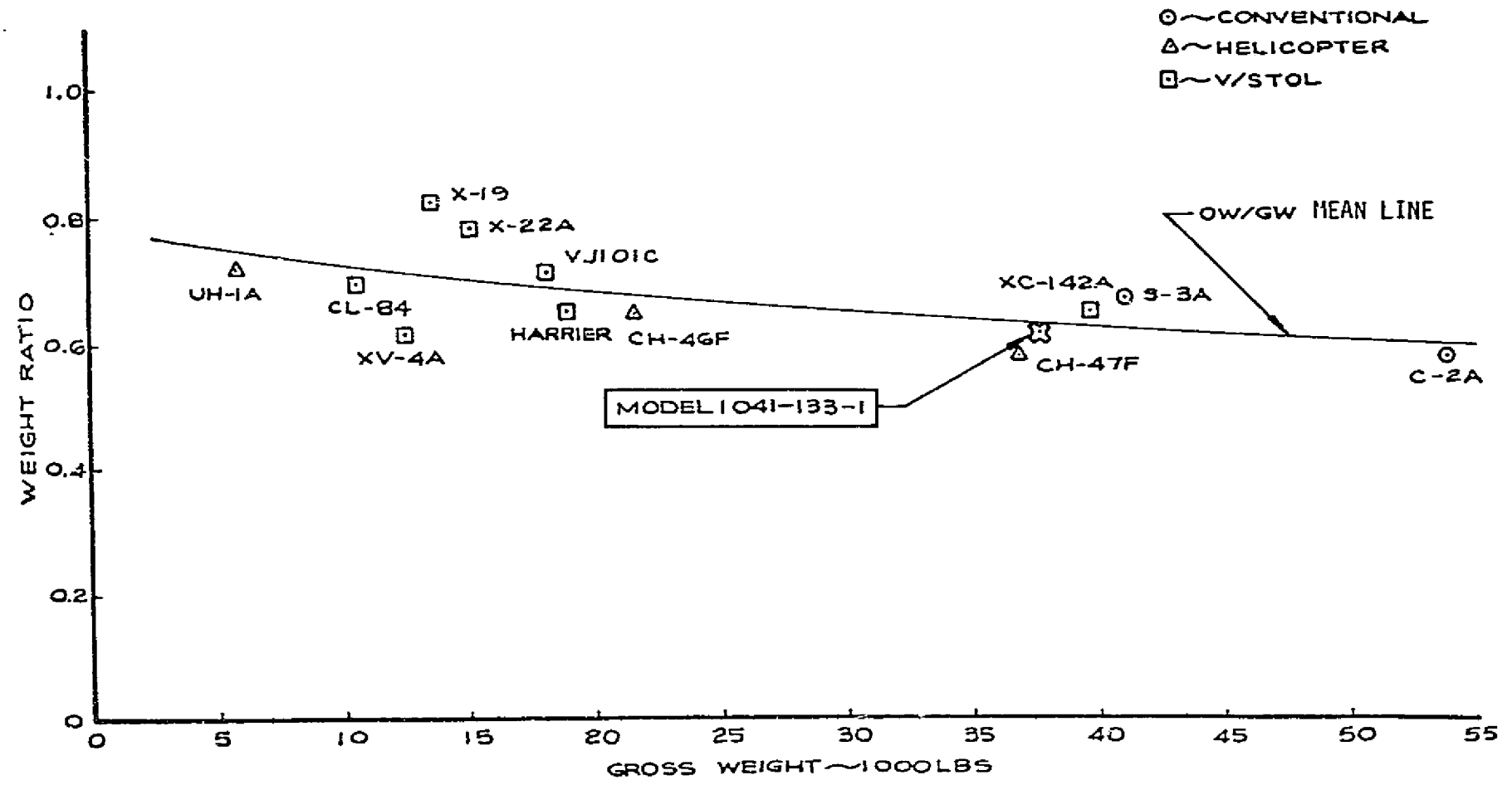

Figure 1-2.-



Table I-1.—Percent Operating Weight Versus Weight Prediction Method ASW Mission

% OPERATING WEIGHT VERSUS WEIGHT PREDICTION METHOD  
ASW MISSION

<u>SOURCE</u>	<u>% O.W.</u>
BOEING	50.0
NASA/NAVY SUPPLIED	13.0
VENDOR QUOTATION	27.0
SCALED FROM S-3A	10.0
	<hr/>
	100.0

Table 1-2.—Typical Parametric/Statistical Weight Method

- o USED TO PREDICT 100% OF THE WING WEIGHT
- o WING WEIGHT = STRUCTURAL BOX <sup>1</sup> + LIFT DEVICES <sup>2</sup> + LATERAL CONTROLS <sup>3</sup> + SECONDARY STRUCTURE <sup>4</sup>, WHERE THE WEIGHT OF:

1 =  $f$  ( $w$ ,  $s_w$ ,  $N$ ,  $T/C$ ,  $R$ ,  $\lambda$ ,  $\Lambda$   $c/4$ , EXPOSED SPAN, DEAD WEIGHT RELIEF, FOLD LOCATION, LANDING GEAR LOCATION, FATIGUE AND GUST CRITERIA)

2 =  $f$  ( $s_w$ ,  $C_{L_{MAX}}$ ,  $\Lambda$   $c/4$ )

3 =  $f$  (CONTROL SURFACE AREAS, TYPE OF AIRPLANE)

4 =  $f$  ( $s_w$ , EXPOSED SPAN)

- o PREDICTS CONVENTIONAL METAL WING
- o MATERIAL & CONSTRUCTION CHANGE FACTORS ARE CONSIDERED

Table I-3.-Lift/Cruise Engine Pod Rotation

	<u>VJ101CX-2</u>	<u>X-22A</u>	<u>LCFA-133-1</u>
ROTATION WEIGHT - LB	410	387	450
THRUST OF ROTATED ENGINES - LBS	15500 ▷	16600	22660
ROTATION WEIGHT/THRUST	0.026	0.023	0.02

LCFA - 133-1 IS NOT CONSTRAINED BY THE DEPTH OF THE WING. THEREFORE, ASSUME A SIMPLER INSTALLATION, DESIGN ANALYSIS REQUIRED.

▷ FOUR RB145 ENGINES, AUGMENTED



APPENDIX J - MAXIMUM LIFT, SPEED AND NACELLE DEFLECTION CHARACTERISTICS  
FOR THE 1041-133-1

Maximum lift, initial buffet, maximum speed and limited nacelle deflection effects have been estimated for the ASW lift fan configuration shown in Figure J-1. Boundaries for buffet onset and maximum lift are shown in Figure J-2. Nacelle deflection effects, including the induced aerodynamic effects, are incomplete due to the lack of suitable data for estimating these configuration sensitive effects. In general, it is believed that favorable induced effects will result from the aft engines when deflected. However, the nose fan will probably have adverse induced effects (suck down) and reduce the favorable effect from the aft engines.

Buffet and Maximum Lift:

The buffet and maximum lift boundaries shown in Figure J-2 for the 133-1 configuration are based on YC-14 wind tunnel data; reference J-1. As the YC-14 wing is similar, i.e., same airfoil, low sweep and approximately the same thickness, it was assumed that buffet and maximum lift for the 133-1 would occur at the same angle of attack. By correcting the lift curve slope for t/c, sweep and aspect ratio, the lift coefficient for the 133-1 buffet and maximum lift boundaries were defined.

Maximum Speed and Sustained Load Factor:

The maximum speed and maximum sustained load factors were determined using the drag polars from reference J-2 and engine data, dated 1/17/75. The 1.0 size engine data used were scaled by 1.922 Appen. B. The following table summarizes these load factors for several conditions.

<u>Condition</u>	<u>LOAD FACTOR</u>		
	<u>n max. sustained</u>	<u>n max. usable</u>	<u>n buffet onset</u>
M = .30 Sea Level	1.52	1.56	1.42
M = .65 10,000 ft.	3.41	3.74	3.38
M = .835* 10,000 ft.	1.0	3.15	2.06

\* Maximum 1g sustained speed at 10,000 ft.

### Induced Aerodynamic Effects Due to Nose Fan and Engine Exhaust:

The operation of the nose fan and the engines when rotated to  $90^{\circ}$  causes induced aerodynamic effects as a result of the exhaust (and inlet) flows circulating about the configuration. The procedure for determining these effects is to separate the basic aerodynamic characteristics and the actual thrust effects from the total forces acting on the vehicle. The difference is the induced aerodynamic effect. These effects are a function of engine thrust, forward air speed and most important, the vehicle's configuration. By applying the principle of superposition, the induced aerodynamic effects can be added to a vehicle's performance in V/STOL modes. Though there is a large quantity of powered model data available, it is not in a form or suitable configuration which makes it possible to determine the induced aerodynamic effects. Because of this, the following data should only be used in a preliminary manner to indicate trends.

The only data reasonably related to predicting the effects of the nose fan was found in reference J-4. The lift data shown in Figure J-4, are non-dimensionalized with fan thrust coefficient,  $C_T$ , and are plotted as a function of effective exhaust velocity,  $V_e = \frac{V_T}{V_{\text{exhaust}}}$ . These results include the vehicle's basic aerodynamic characteristics, the direct thrust has been taken out. However, the data does indicate a significant detrimental effect on liftout of ground effect, especially as  $V_e$  increases (or  $V_{\text{exhaust}}$  decreases). These results are expected to be typical for the 133-1 with only the nose fan operating; however the induced aero effect, the vehicle's basic aerodynamic characteristics and the effect of the cruise engines cannot be separated out.

The induced aerodynamic effect shown in Fig. J-5 with the aft engines rotated to  $90^{\circ}$  were estimated from data in reference J-5.

These data are true induced effects as the vehicle's aerodynamic characteristics were measured with and without jet effects and the thrust was not attached to the model. The data had to be extrapolated extensively to match the exhaust location on the 133-1. The exhaust jet located at 25% semi-span instead of next to the body, the flap configuration was not the same as the 133-1 and the data were taken with exhaust flow only-no inlet was present.

Corrections were not made for these differences. However, these data can be used as a general guide as to the expected trends. In general, locating the exhaust aft of the wing trailing edge produces favorable effects which increase with flap deflection. Jet exhaust locations ahead of the wing leading edge give adverse interference effects.

## REFERENCES:

1. YC-14 Aerodynamics Staff, "Cycle VII Rigid Flaps up Longitudinal Characteristics," Boeing Coord. Sheet YC-14-FC-042, February 1975.
2. N. Baullinger, "Drag Polar Estimates for the ASW Lift Fan Configuration, Model 1041-133-1," Attachment to Coord. Sheet 2-5700-000-119, May 30, 1975. (Included in Task I of this report).
3. Hall, L. P., et al., "Aerodynamic Characteristic of a Large Scale V/STOL Transport Model with Lift and Lift-cruise Fans," NASA TN D-4042, August 1967.
4. Kirk, J. V., et al, "Aerodynamic Characteristics of a Full Scale Fan-in-Wing Model Including Results in Ground Effect with Nose-Fan Pitch Control," NASA TN D-2368, July 1964.
5. Carter, A. W., "Effects of Jet-Exhaust Locations on the "Longitudinal Aerodynamic Characteristics of a Jet V/STOL Model," NASA TN D-5333, July 1969.
6. G. Letsinger, "Aerodynamic Stability and Control Characteristics for the ASW Lift Fan Configuration, Model 1041-133-1," Attachment to Coord. Sheet 2-5700-000-117. (Included in Task III of this report).

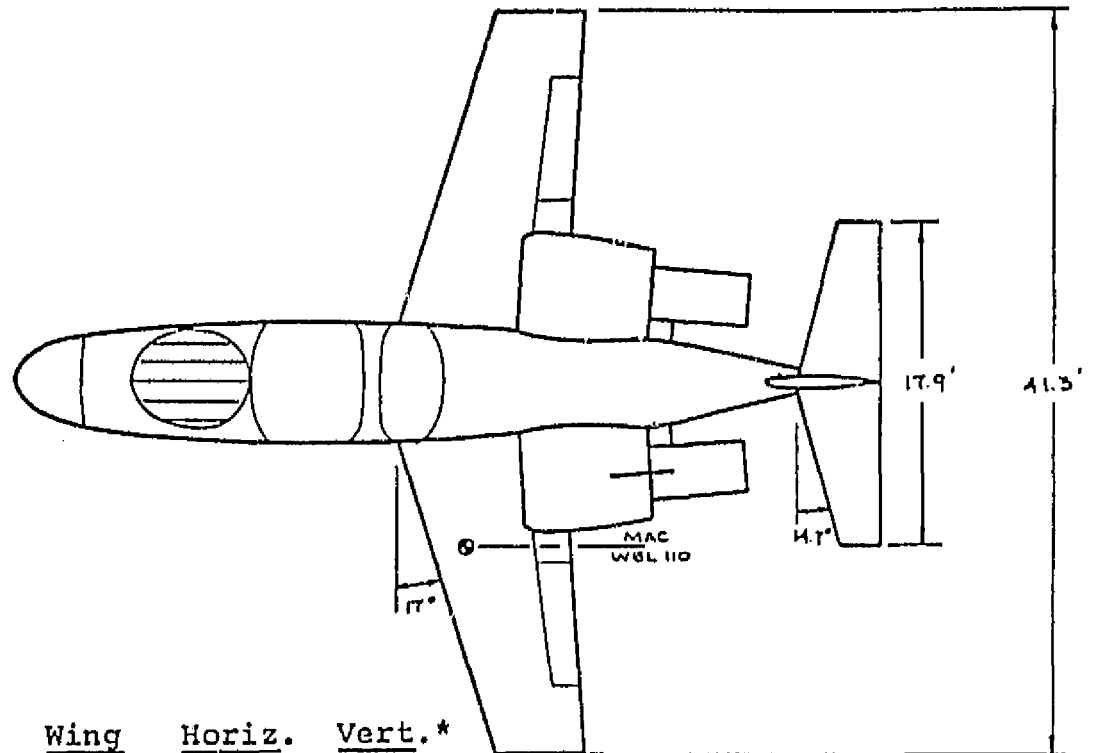

	<u>Wing</u>	<u>Horiz.</u>	<u>Vert.*</u>
$\Lambda_{LE} \sim \text{Deg}$	17	14.7	35
AR	5.5	5.0	3.3
$\lambda$	.5	.5	.58
Area $\sim \text{ft}^2$	310	64	30
MAC $\sim \text{ft}$	7.81	3.7	
Semi-span $\sim \text{ft}$	20.65	8.95	5.0

\* Parameters assuming bottom of vertical is in line with top of body

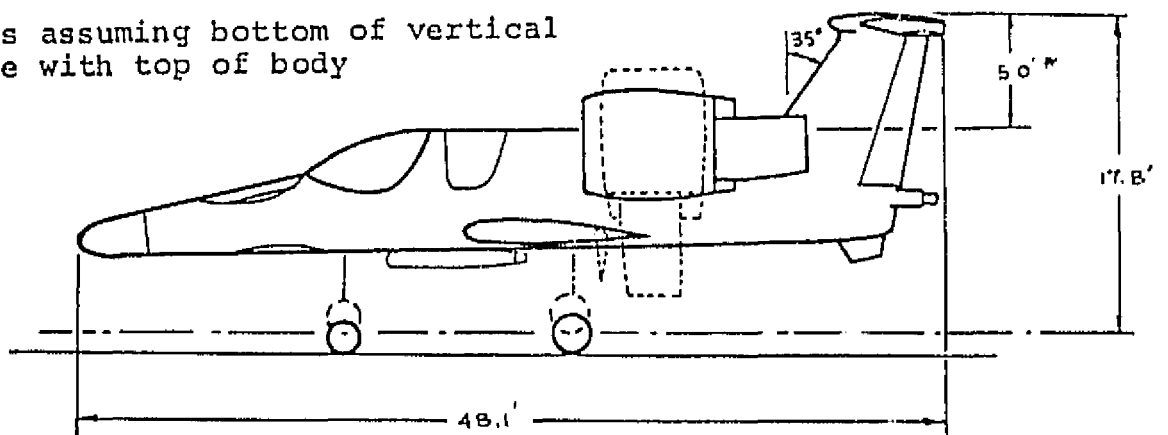

Figure J-1.-ASW Lift Fan Configuration

BOUNDARIES BASED ON YC-14 WIND  
TUNNEL DATA - CORRECTED FOR  
AR,  $\Delta$  AND T/C

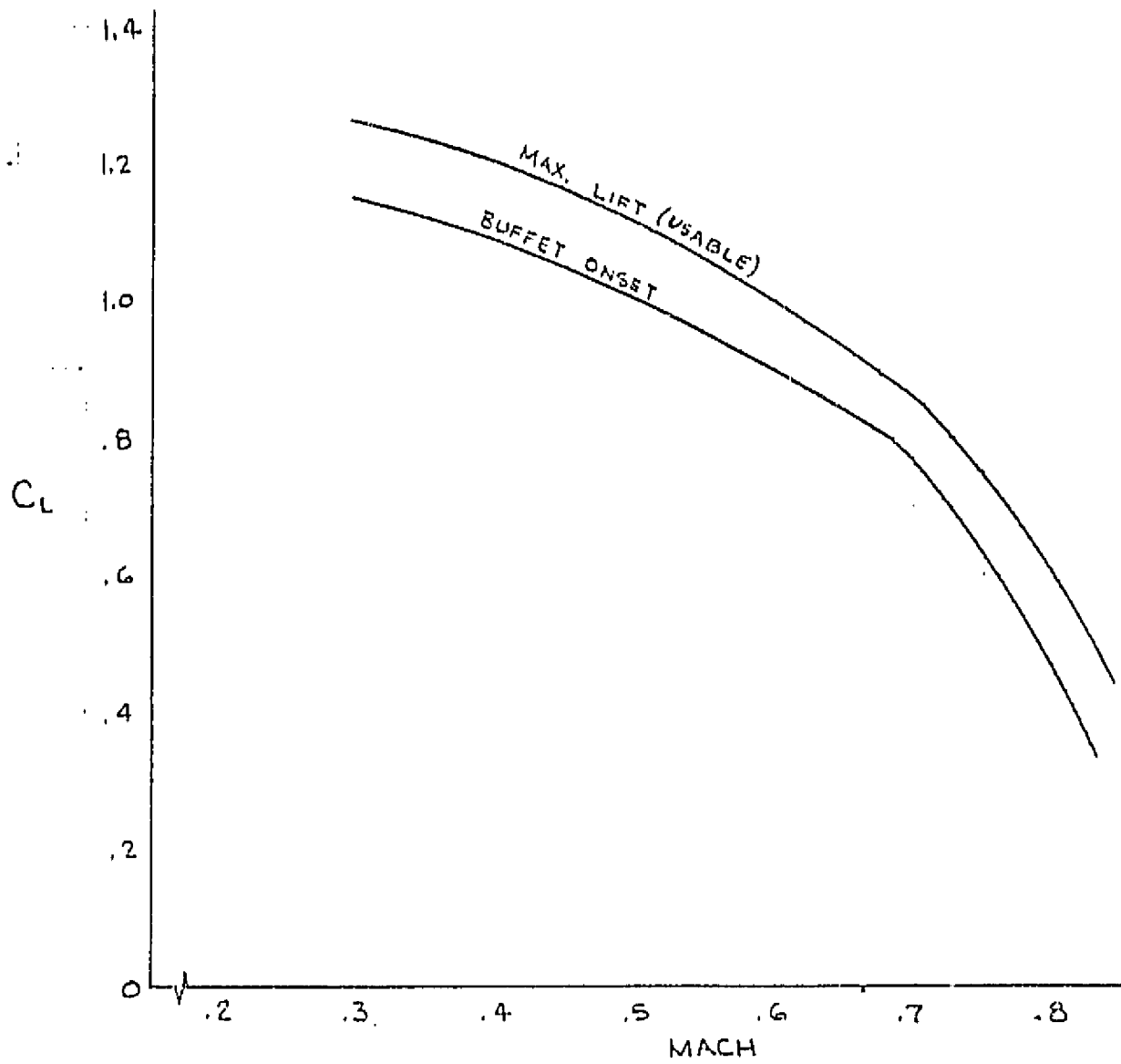
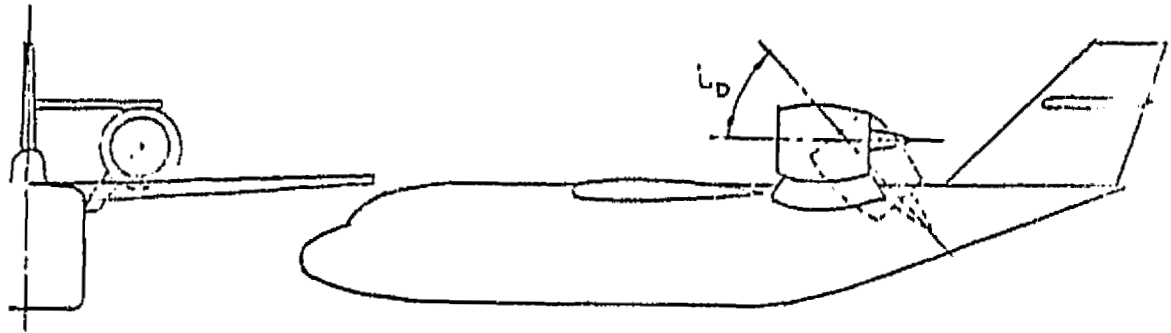

Figure J-2.-Maximum Lift and Buffet Onset Boundaries for the 1041-133-1

ORIGINAL PAGE IS  
OF POOR QUALITY



CONFIGURATION DATA BASE

$A_{\pi}$  = NACELLE FRONTAL AREA  
BASED ON MAX. DIAMETER

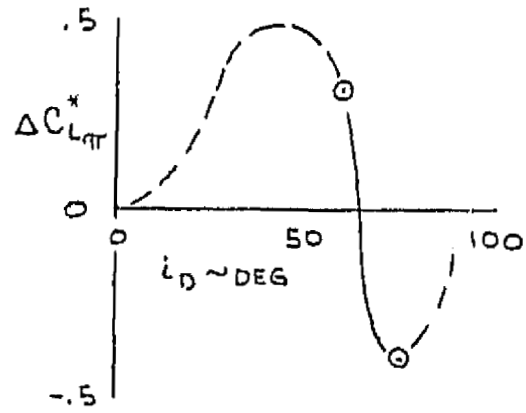
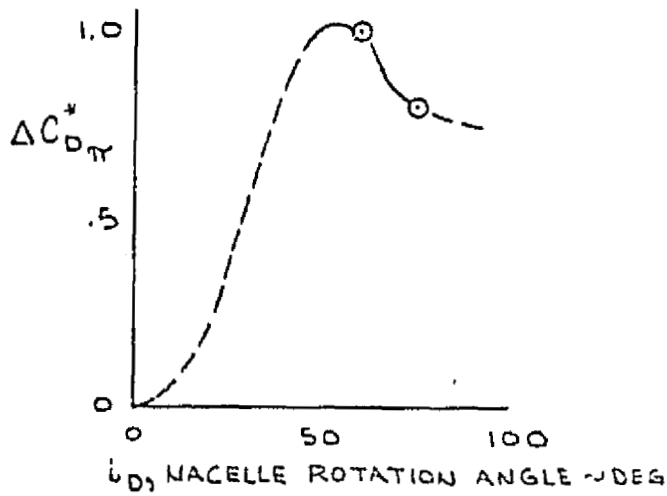

\* BASED ON  $A_{\pi}$   
FAN WINDMILLING

REF. NASA TN D-4092

Figure J-3.-Variation of Nacelle Lift and Drag With Nacelle Rotation

ORIGINAL PAGE IS  
OF POOR QUALITY

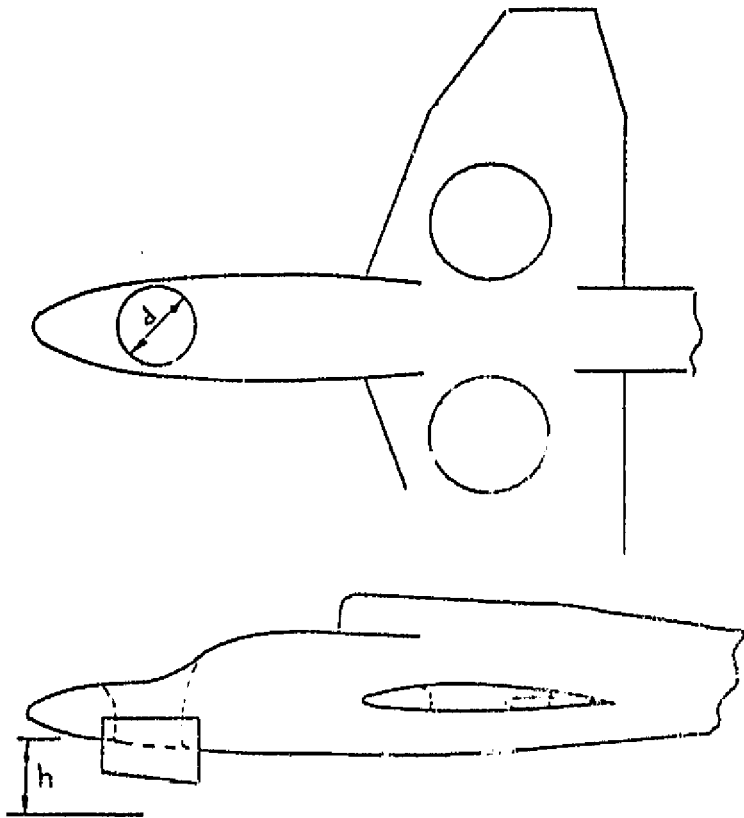

h = HEIGHT ABOVE GROUND  
 d = FAN DIAMETER

$$V_e = \frac{V_{co}}{V_{EXHAUST}}$$

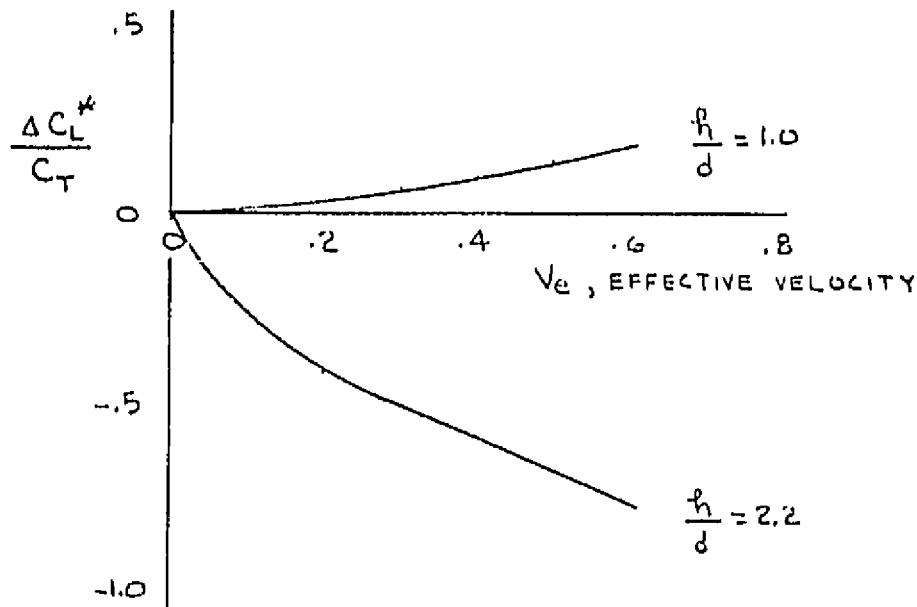

\* THESE DATA INCLUDE THE POWER OFF AERO CHARACTERISTICS WHICH ARE UNKNOWN. THE FAN THRUST HAS BEEN SUBTRACTED OUT ( $C_T$ )

REF. NASA TN D-2368

Figure J-4.-Resultant Lift Effects Due to Operation of Forebody (Nose) Fan



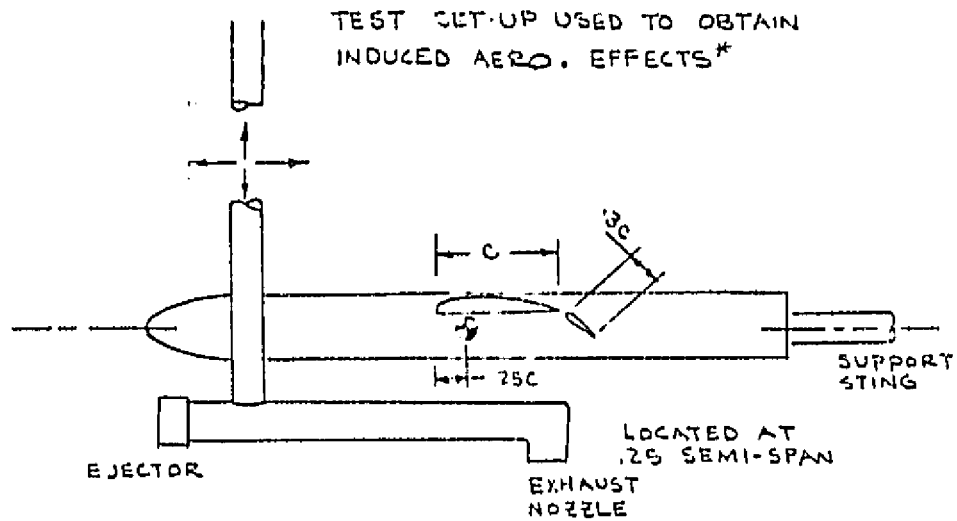

1041-133-1

ESTIMATED INDUCED AERODYNAMIC EFFECTS

JET DEFLECTION ANGLE =  $90^\circ$

EXHAUST LOCATION AT  $X/C = 1.18$ ,  $Z/C = -.37$

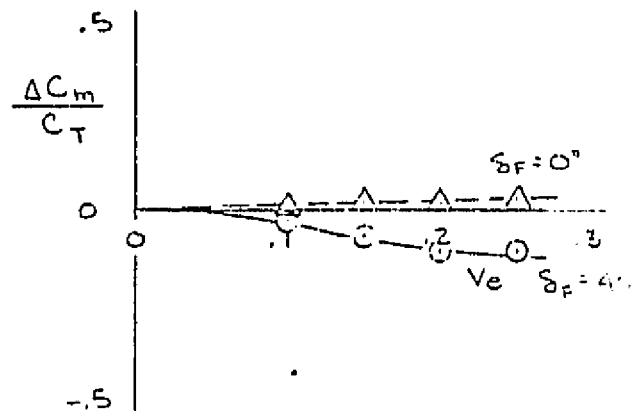
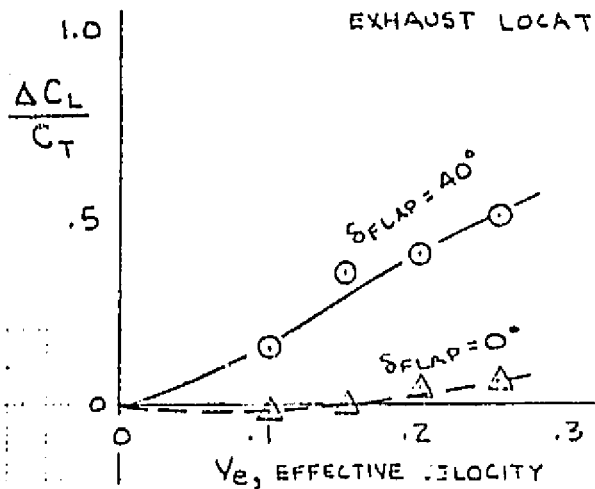

NOTE:

DATA POINTS SHOWN WERE OBTAINED FROM FAIRED CURVES WHICH WERE THEN EXTRAPOLATED TO COINCIDE WITH THE APPROX. LOCATION OF THE CORE FLOW ON THE 133-1 WITH NACELLES AT  $90^\circ$

\* REF. NASA TN D-5333

Figure J-5.-Estimated Induced Aero Effects for the 1041-133-1

ORIGINAL PAGE IS  
OF POOR QUALITY